

ASME SECTION XI VALVE TEST PROGRAM

2ND TEN YEAR INSPECTION INTERVAL

FOR THE D. C. COOK NUCLEAR POWER STATION UNIT NO. 1

Revision No: 3

Date: 2-5-90

TABLE OF CONTENTS

1. INTRODUCTION - (FIGURE - 1)
2. LIST OF DRAWINGS - (FIGURE - 2)
3. NOMENCLATURE FOR TEST METHODS - (FIGURE - 3)
4. RELIEF REQUEST/COLD SHUTDOWN JUSTIFICATION NOTES
5. ATTACHMENT-A
6. VALVE SUMMARY SHEETS
7. FLOW DIAGRAMS

9003090184 900216
PDR ADOCK 05000315
P PNU

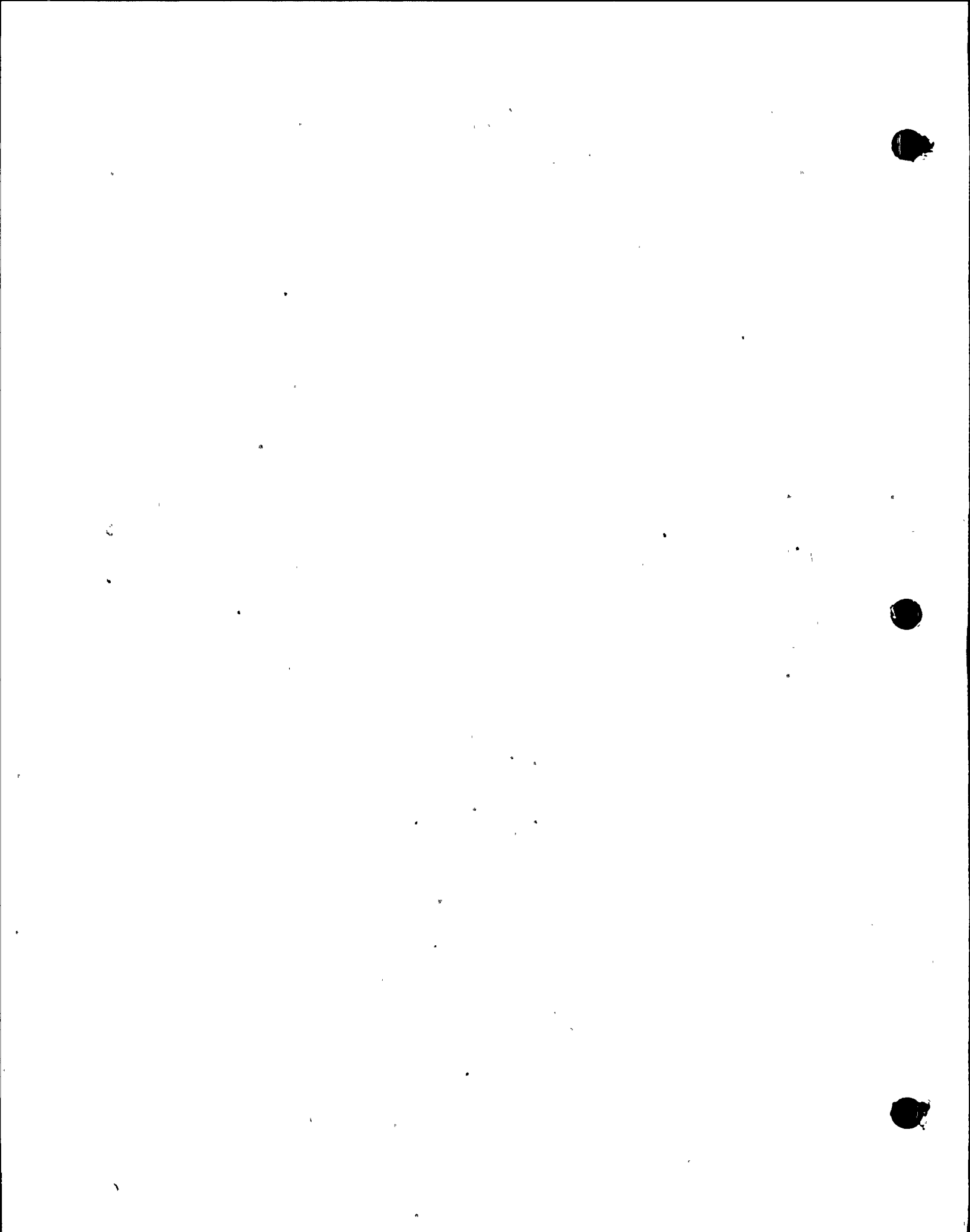

ASME SECTION XI VALVE TEST PROGRAM

2ND TEN YEAR INSPECTION INTERVAL

FOR THE D. C. COOK NUCLEAR POWER STATION UNIT NO. 1

Revision No: 3

Figure - 1

Date: 2-5-90

INTRODUCTION

1. Valve Testing Program

- A. The valve test program shall be conducted in accordance with Subsection IWV of Section XI of the 1983 edition of the ASME Boiler and Pressure Vessel Code through Summer 1983 Addenda, except for specific relief requests which are identified in the Valve Summary Sheet.
- B. The valve test program is applicable for the second 10 year inspection interval which commences on July 1, 1986.
- C. The valve test program was developed employing the classification guidelines contained in 10 CFR 50.2(v) for Quality Group A and Regulatory Guide 1.26, Revision 3 for Quality Groups B and C. (Quality Group A is the same as ASME Class 1, Group B is 2, and Group C is 3). NRC staff guidance was provided by memorandum dated January 16, 1978.
- D. Figure 2 identifies the system flow diagrams which were used to develop this valve test program.

Valve Summary Sheets contain the following:

- * System Name: Name of the system (e.g., Main Steam)
- * Flow Diagram: Unit Number - Flow diagram number - Revision Number
(e.g., 1-5105B-42)
- * Valve Number: Unique valve number (e.g., 1-DCR-310)

D. C. Cook Nuclear Plant

Valve Test Program

Revision No: 3

Figure - 1

Date: 2-5-90

- * Revision Number: Any change of valve description, function or test requirement.
- * Valve Type: Type of valve, one of the following:
 - REL - Relief and Safety
 - CK - Check
 - BF - Butterfly
 - GA - Gate
 - GL - Globe
 - DA - Diaphragm
 - 3W - Three-Way
 - ND - Needle
 - AG - Angle
 - BL - Ball
 - VB - Vacuum Breaker (Reverse Check Valve)
- * Valve Size: Nominal valve size in inches
- * Valve Actuator Type: Type of actuator, one of the following:
 - SA - Self Actuated (e.g., CK or REL)
 - MO - Motor Operated
 - A - Air Operated
 - M - Manual
 - PO - Pneumatic
 - SO - Solenoid Operated
- * Flow Diagram Coordinates: Alpha/Numeric grid location of valve

D. C. Cook Nuclear Plant

Valve Test Program

Revision No: 3

Figure - 1

Date: 2-5-90

* Valve position during normal plant operation or during performance of its safety function, one of the following:

- O - Open
- C - Closed
- O/C - Open/Closed or vice versa

* Code Class: ASME Code class of valve, either 1, 2, or 3

* Valve Status-A/P: Active or passive

* Category: Section XI, Category of valve, either A, B, C, or D, as defined in IWV-2200

NOTE: Combinations are possible (e.g., AC)

* Primary Test Req'd: Test required per Section XI

* Test Performed: Testing that will be performed

NOTE: Test nomenclature is explained in Figure 3

* Test Mode (Test Frequency): One of the following:

- P - Every 3 months while system is required to be operable.
- C - Testing will be performed at cold shutdown frequency (See Note "F").
- R - Testing will be performed at refueling outage frequency.

D. C. Cook Nuclear Plant

Valve Test Program

Revision No: 3

Figure - 1

Date: 2-5-90

* Code Relief: Whether or not a code relief is being requested; will be one of the following:

- NO - Valve is to be tested per code, no comments.
- NO, NOTE X - Valve is to be tested per code, but there are comments.
- NO, CSJ Y - Valve is to be tested per code at a cold shutdown frequency with cold shutdown justification provided in notes.
- YES, NOTE Z - Code relief is requested. Alternate testing is proposed in lieu of that required by code, the note explains why the code relief is requested.

E. Alternative testing performed on a check valve in accordance with GL-89-04, Attachment 1, Item #2 is indicated under relief request notes. This testing is performed in lieu of stroke testing required by Section XI, IWV-3521. This is accomplished by disassembly method in the following manner:

Disassembly Method The valve bonnet is removed, the disc is manually full stroke exercised and the valve internals are visually examined. The results of this examination are documented. This will be performed on a refueling outage frequency. The valve groupings for sample disassembly is in accordance with GL-89-04. This alternative testing to be performed for a particular valve is indicated on the valve summary sheets and relief request notes.

Valve Test Program

Revision No: 3

Figure - 1

Date: 2-5-90

- F. Scheduling of Valve Testing at Cold Shutdown Frequency. Valves tested at a cold shutdown frequency shall be scheduled using the following criteria:
1. Valve exercising need not be done more often than once every 3 months in case of frequent cold shutdowns.
 2. The testing shall commence as soon as the cold shutdown condition is achieved, but not later than 48 hours after shutdown, and continue until complete or the plant is ready to return to power.
 3. Completion of all valve testing is not a prerequisite to return to power. Any testing not completed during one cold shutdown should be performed during any subsequent cold shutdowns starting from the last test performed at the previous cold shutdown.
 4. For planned cold shutdowns, where ample time is available and testing all the valves identified for the cold shutdown test frequency in the IST Program will be accomplished, exceptions to the 48 hours commencement of testing is allowed.
- G. The following criteria have been used in developing limiting values of full-stroke time for the power operated valves:
- o Review of valve's design specification and/or manufacturer's test stroke times
 - o Review of system response time requirements (Technical Specification, FSAR, etc.)
 - o Valve's historical stroke time values at various system conditions

D. C. Cook Nuclear Plant
Valve Test Program

Revision No: 3

Figure - 1

Date: 2-5-90

Using the above criteria, the limiting stroke time for each valve is derived as follows:

1. Nominal Valve Stroke Time \leq 2 Seconds*

<u>Historical Stroke Time Range in Seconds</u>	<u>Established Base Line on Curves in Seconds</u>	<u>Recommended Action Time (Limiting Stroke Time Values in Seconds)</u>
		Base Line Time x 2 + 1 Second=Recommended Action Time or Tech. Spec. Limit, whichever is less.
up to to 1.24	1.0	= 1 x 2 + 1 = 3 Seconds
1.25 to 1.74	1.5	= 1.5 x 2 + 1 = 4 Seconds
1.75 to 2.49	2.0	= 2 x 2 + 1 = 5 Seconds

2. Nominal Valve Stroke Time - 3.0 to 10.0 Seconds

2.5 to 10.49	3 to 10	Base Line Time x 1.5 = Action Time
--------------	---------	---------------------------------------

3. Nominal Valve Stroke Time - 11.0 Seconds and Up

10.5 and Up	11.0 and Up	Base Line Time x 1.25 = Action Time (or 15 seconds, whichever is larger)
-------------	-------------	--

*Excluding those valves designated as rapid valves per Paragraph "H" noted below.

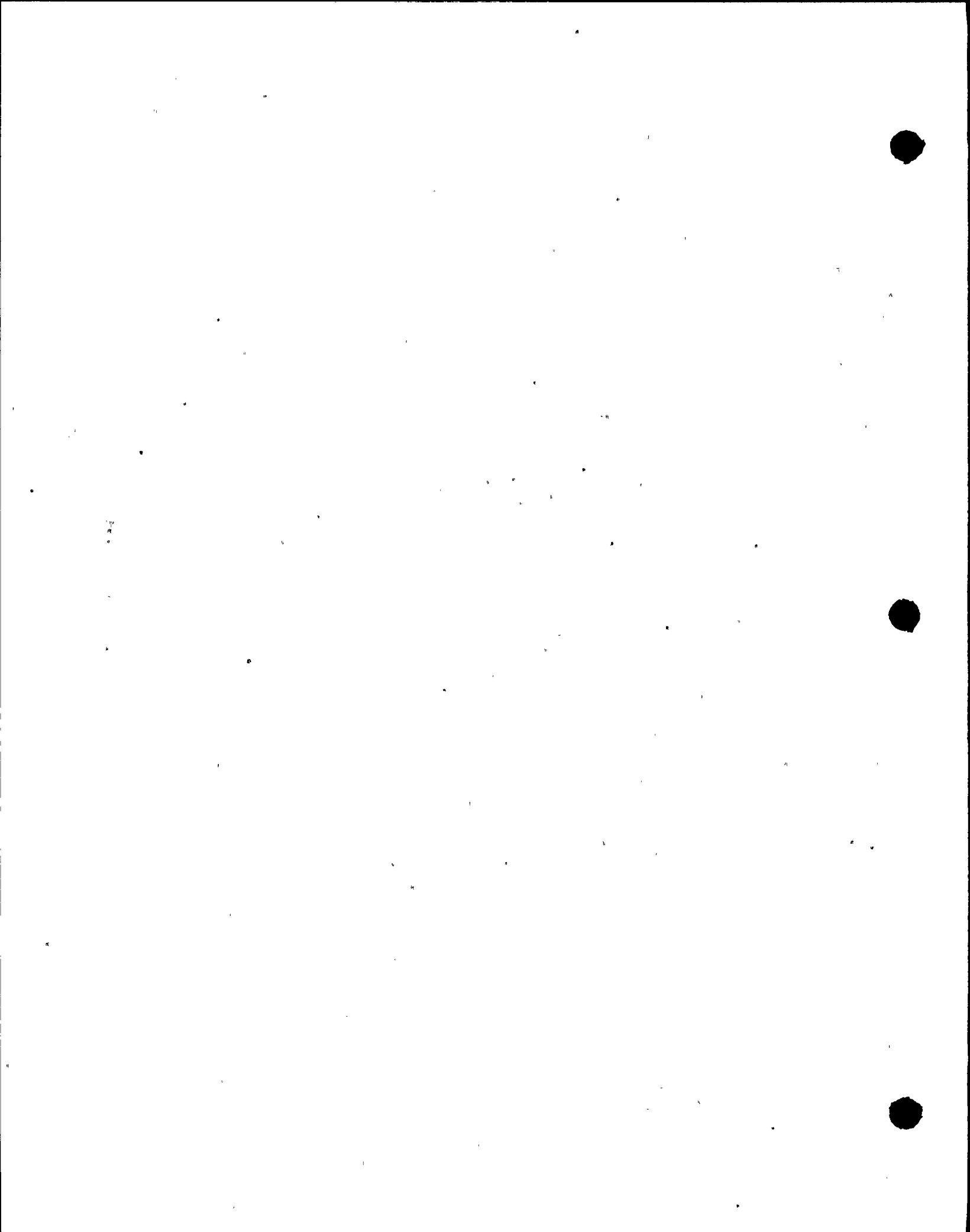

D. C. Cook Nuclear Plant

Valve Test Program

Revision No: 3

Figure - 1

Date: 2-5-90

The stroke time limiting values for the power operated valves will be controlled via plant Technical Data Book.

- H. Stroke Time Measurements for Rapid (Fast) Acting Valves. In accordance with GL-89-04, Attachment 1, Item #6, power operated valves with normal stroke times of 2 seconds or less may be assigned 2 seconds limiting values. If a valve is assigned a 2 second limiting value, it shall be timed only and not trended in accordance with Section XI, IWV-3417a. If the valve exceeds 2 second limit, it will be declared inoperable and corrective actions will be taken in accordance with IWV-3417(b). The major influence in the stroke time testing of rapid acting valves is the operator's response. Therefore, the timing tolerances are influenced by the operator action and trending is not indicative of valve performance. The valve limiting values will be documented in the plant Technical Data Book. The results of these tests will be documented via plant procedures.

DONALD C. COOK NUCLEAR PLANT
2ND TEN YEAR INSPECTION INTERVAL OF
VALVE TEST PROGRAM FOR UNIT - 1

LIST OF DRAWINGS

Revision No: 3

Figure 2

Date: 2-5-90

<u>NO.</u>	<u>SYSTEM</u>	<u>FLOW DIAGRAM NO.</u>	<u>REVISION</u>
	Main Steam	1-5105	29
	Main Steam	1-5105B	35
	Steam Generating System	1-5105D	1
	Feedwater	1-5106	35
	Feedwater (Auxiliary)	1-5106A	38
	Essential Service Water	1-5113	41
	Non-Essential Service Water	1-5114A	31
	Station Drainage Containment	1-5124	22
	Reactor Coolant	1-5128	19
	Reactor Coolant	1-5128A	37
	CVCS-Reactor Letdown & Charging	1-5129	31
		1-5129A	19
	Component Cooling	1-5135	35
	Component Cooling	1-5135A	30
	Component Cooling	1-5135B	14
	Nuclear Sampling	1-5141	29
	Nuclear Sampling	1-5141A	32
	Post Accident Sampling-Containment Hydrogen	1-5141D	10

DONALD C. COOK NUCLEAR PLANT
2ND TEN YEAR INSPECTION INTERVAL OF
VALVE TEST PROGRAM FOR UNIT - 1
LIST OF DRAWINGS

Revision No: 3

Figure 2

Date: 2-5-90

<u>SYSTEM</u>	<u>FLOW DIAGRAM NO.</u>	<u>REVISION NO.</u>
Emergency Core Cooling (SIS)	1-5142	25
Emergency Core Cooling (RHR)	1-5143	36
Containment Spray	1-5144	28
Containment Penetration & Weld Channel Pressurization	1-5145	17
Ice Condenser Refrigeration	1-5146B	24
Containment Ventilation	1-5147A	34
Control Room Ventilation	1-5149	20
Emergency Diesel Generator	1-5151A	25
Emergency Diesel Generator	1-5151B	28
Emergency Diesel Generator	1-5151C	26
Emergency Diesel Generator	1-5151D	28
Make-Up Water & Primary Water System	12-5115A	41
Compressed Air System	12-5120B	22

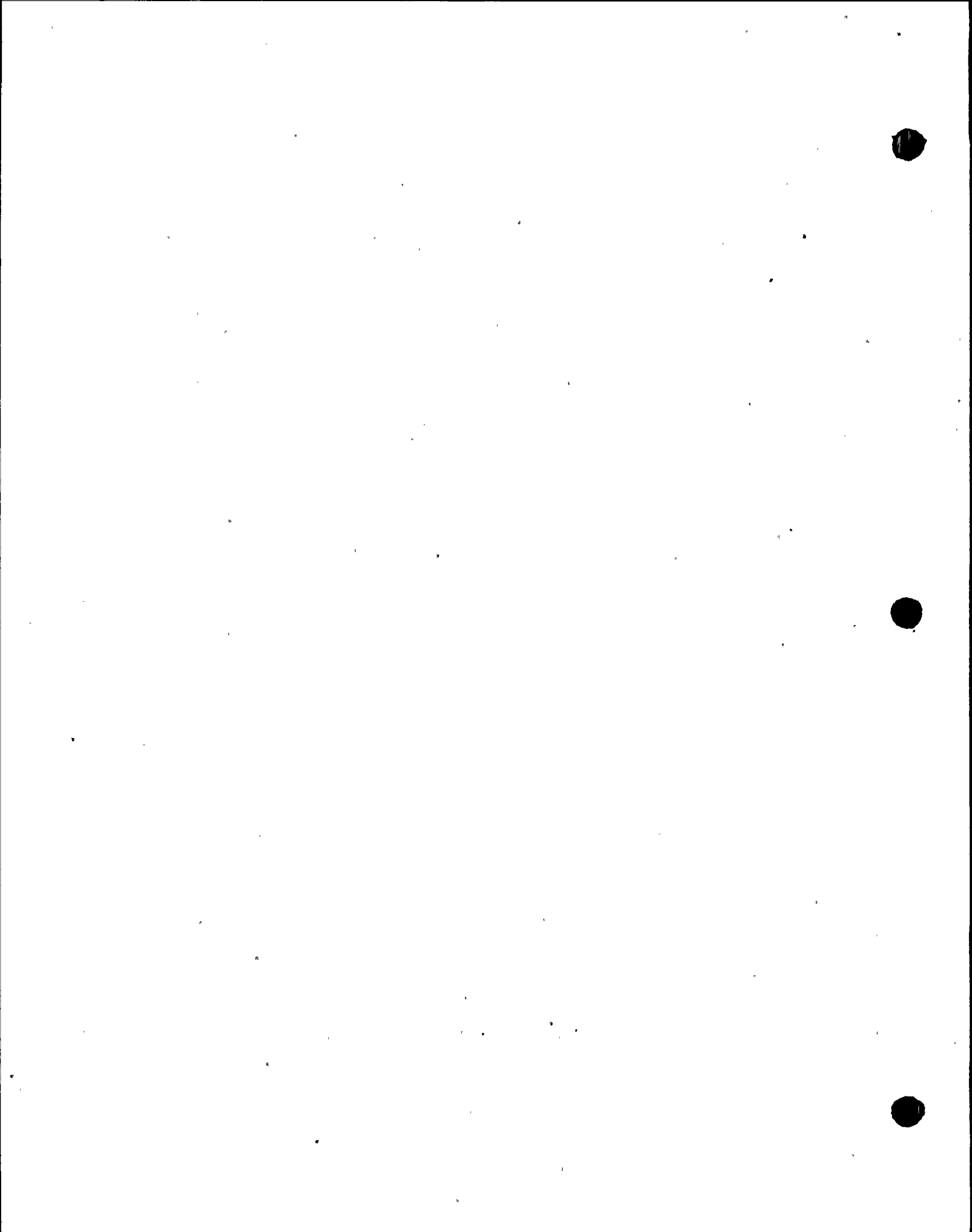

DONALD C. COOK NUCLEAR PLANT
2ND TEN YEAR INSPECTION INTERVAL OF
VALVE TEST PROGRAM FOR UNIT - 1

LIST OF DRAWINGS

Revision No: 3

Date: 2-5-90

Figure 2

<u>SYSTEM</u>	<u>FLOW DIAGRAM NO.</u>	<u>REVISION NO.</u>
CVCS-Boron Makeup	12-5131	19
Spent Fuel Pit Cooling & Clean-Up	12-5136	25
WDS Vents & Drains	12-5137A	21
Post Accident Liquid & Gas Sampling	12-5141C	8
Post Accident Liquid Sampling Inst. Panels	12-5141F	6

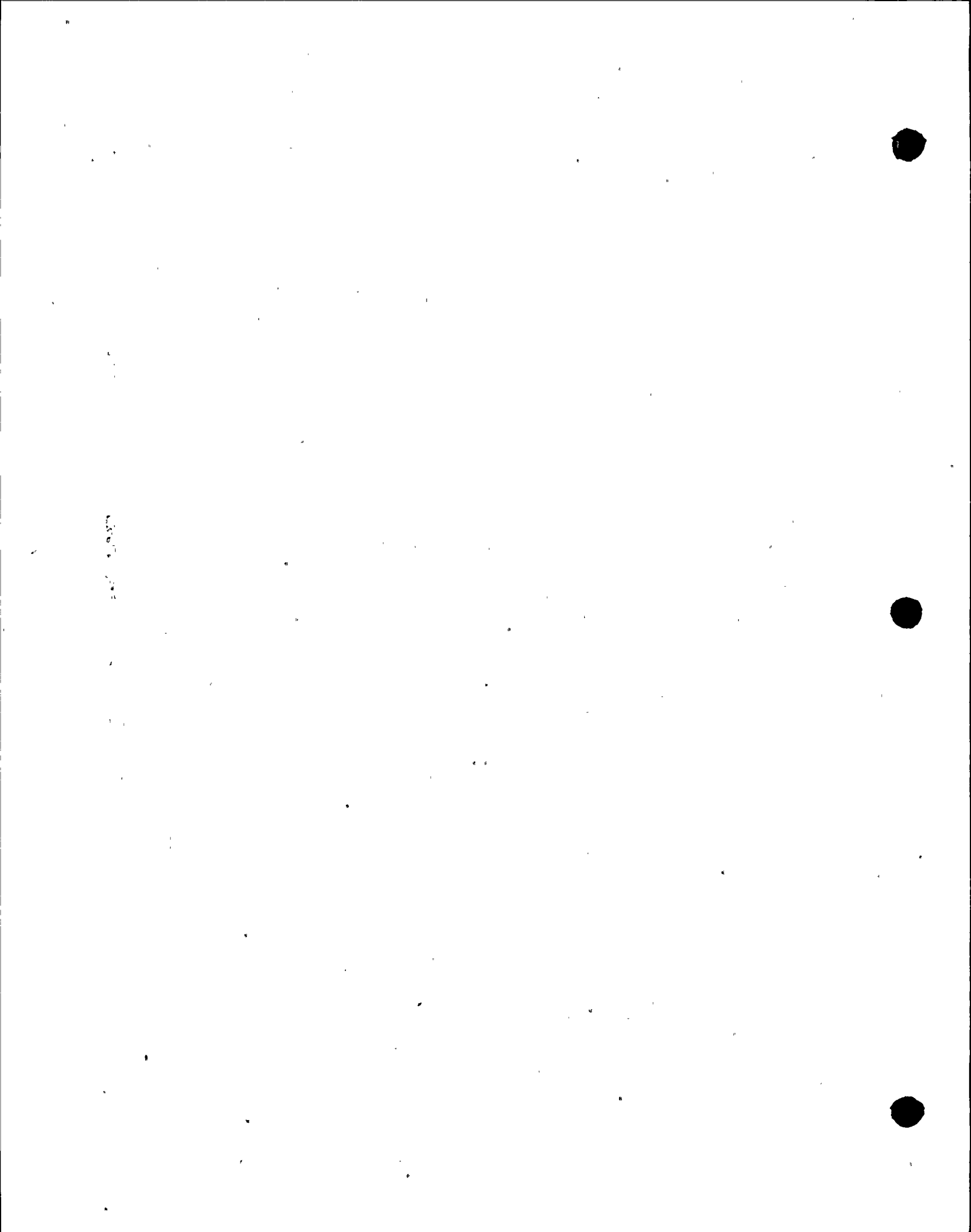

DONALD C. COOK NUCLEAR PLANT
NOMENCLATURE FOR TEST METHODS
USED IN COLUMNS FOR PRIMARY TEST REQUIRED AND
TEST PERFORMED UNDER ASME SECTION XI

Revision No: 3

Figure 3

Date: 2-5-90

1) CATEGORY A-B VALVES

ASME CODE SECTION XI
PARAGRAPH

EF-1	Exercise valve (full stroke) for operability quarterly (3 months).	(IWV-3411)
EF-2	Exercise valve (full stroke) for operability at a cold shutdown frequency or refueling outage frequency as indicated. Code relief requests and/or cold shutdown justification are provided in the corresponding valve notes.	(IWV-3412)
EF-3	Exercise valve (part stroke) for operability quarterly; exercise (full stroke) at a cold shutdown frequency or refueling outage frequency as indicated. Justification for exercising the valve at cold shutdown frequency is provided in the corresponding valve notes. Code relief request is provided if full stroke test is deferred to coincide with refueling frequency.	(IWV-3412)
EF-4	Exercise valve (full stroke) for operability prior to return to service	(IWV-3416)
EF-5	Valves with remote position indicator shall be observed at least once every 2 years to verify that valve operation is accurately indicated.	(IWV-3300)
EF-6	This note was intentionally deleted.	
EF-7	Exercise valve (with fail-safe actuators) to observe failure mode quarterly.	(IWV-3415)
EF-8	Exercise valve (with fail-safe actuators) to observe failure mode at a cold shutdown frequency or refueling frequency as indicated.	(IWV-3415)

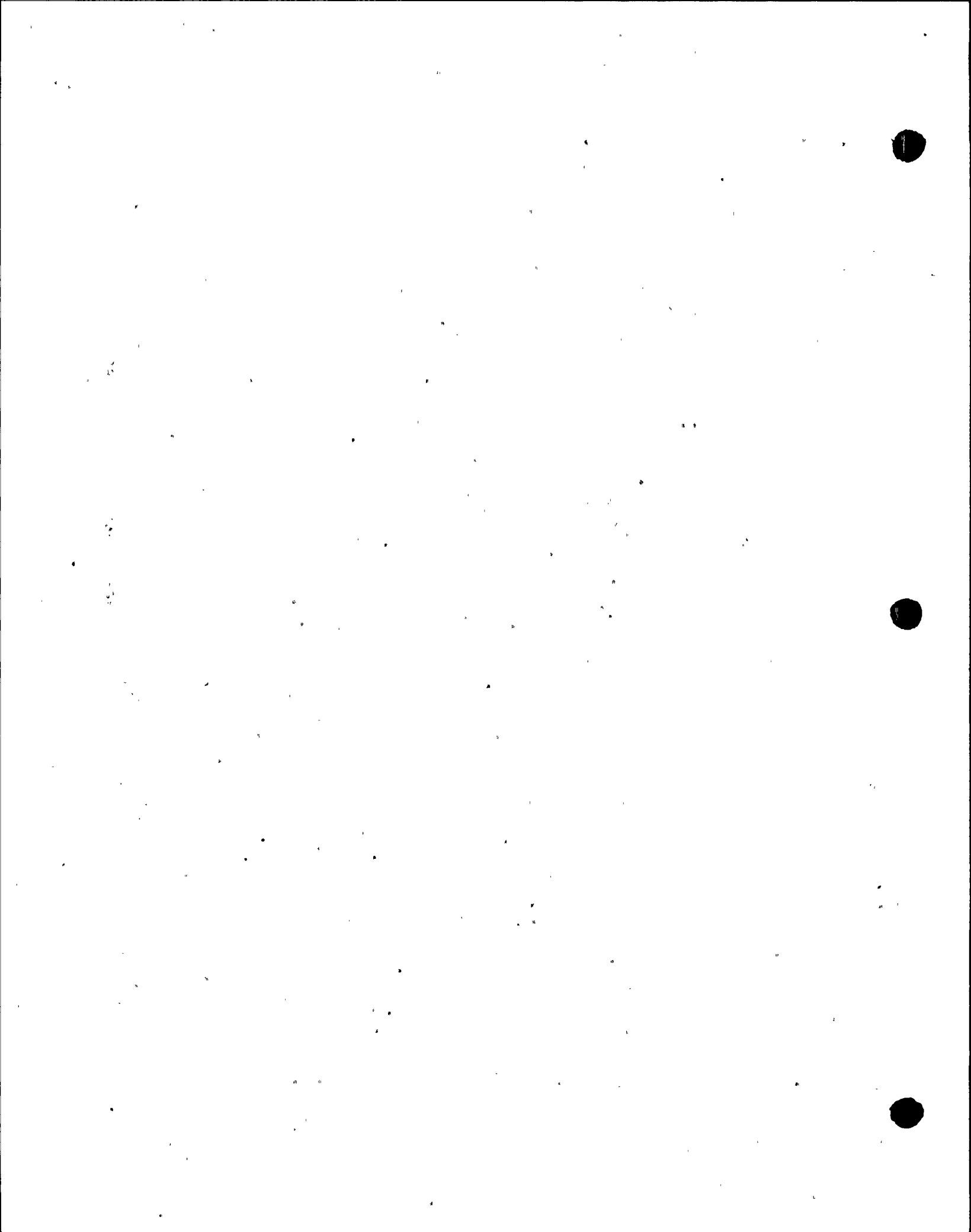

DONALD C. COOK NUCLEAR PLANT
NOMENCLATURE FOR TEST METHOD USED IN COLUMNS FOR
PRIMARY TEST REQUIRED AND TEST PERFORMED UNDER ASME SECTION XI

Revision No: 3

Figure 3

Date: 2-5-90

(cont'd)	<u>1) CATEGORY A-B VALVES</u>	<u>ASME CODE SECTION XI PARAGRAPH</u>
ET-XXX	Exercise power operated valve (full stroke) to its safety position and measure time. The stroke time limiting values of these valves including rapid acting valves will be identified and controlled per plant Technical Data Book and plant procedures. Valves assigned 2 seconds limiting values are subject to relief specified in "Paragraph H, Figure 1."	(IWV-3413&3417)
	<u>2) CATEGORY C VALVES</u>	
CF-1	Exercise valve (full stroke) for operability quarterly.	(IWV-3521)
CF-2	Exercise valve (full stroke) for operability at a cold shutdown frequency or refueling outage frequency as indicated. Code relief requests and/or cold shutdown justification are provided in the corresponding valve notes.	(IWV-3521)
CF-3	Exercise valve (part stroke) for operability quarterly; exercise (full stroke) for operability at a cold shutdown frequency or refueling frequency as indicated. Justification for exercising valves at a cold shutdown frequency is provided in the corresponding valve notes. Code relief requests are provided if full stroke testing is deferred to coincide with refueling frequency.	(IWV-3522)
CF-4	Exercise valve (full stroke) for operability prior to return to service.	(IWV-3416)
TF-1	Safety and relief valve tests (setpoint) to Section XI, Table IWV-3510-1.	(IWV-3510)

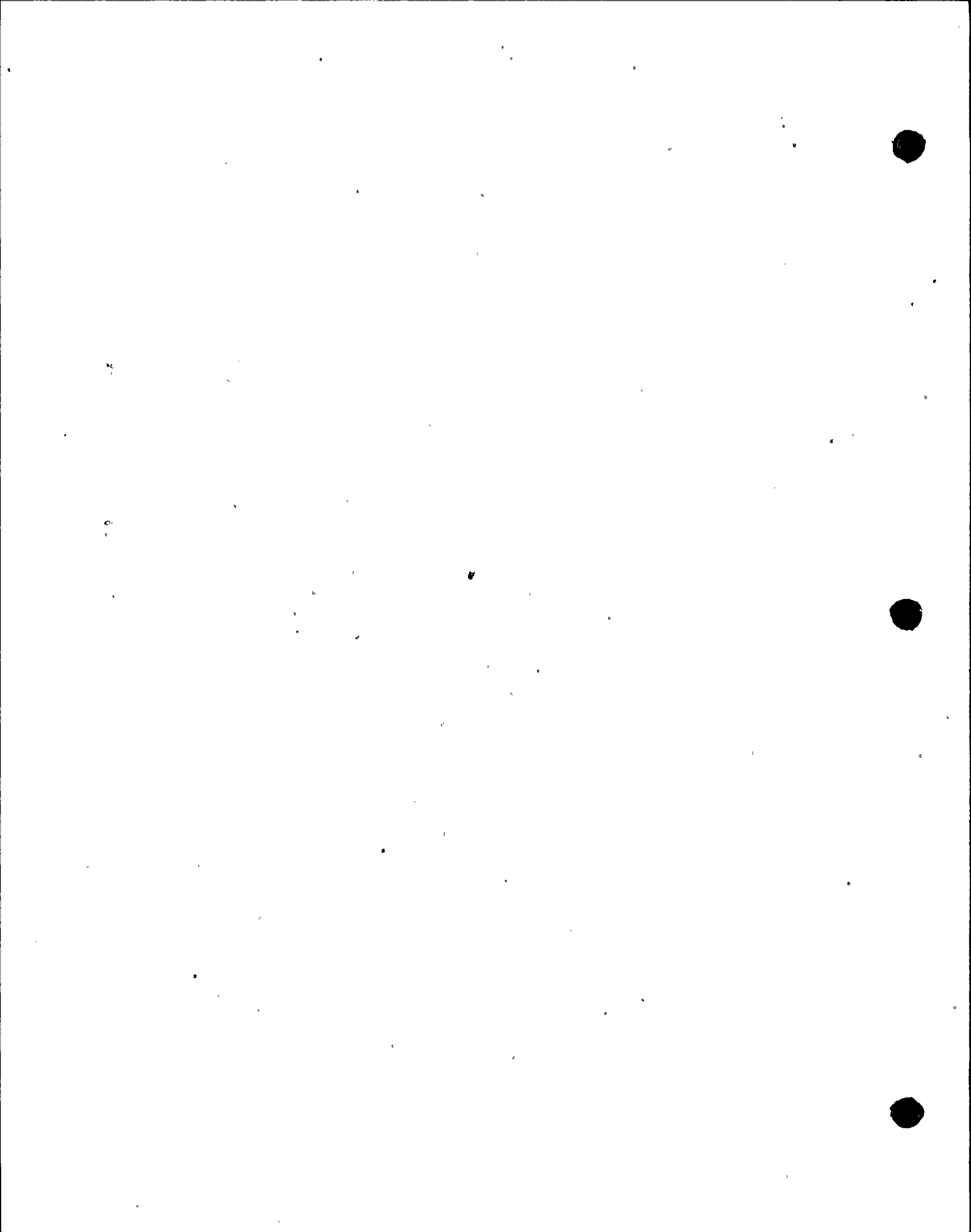

DONALD C. COOK NUCLEAR PLANT
NOMENCLATURE FOR TEST METHODS
USED IN COLUMNS FOR PRIMARY TEST REQUIRED AND
TEST PERFORMED UNDER ASME SECTION XI

Revision No: 3

Figure 3

Date: 2-5-90

3) CATEGORY A or AC VALVES

- SLT-1 Seat leakage test valve in accordance with requirements of paragraph IWV-3420 of ASME Code, Section XI, at refueling outage frequency but not less than once every two years. Permissible leakage values for each category A or AC valve are listed in Attachment - "A".
- SLT-2 Seat leakage test valve in accordance with 10CFR 50, Appendix J, in lieu of ASME Code Section XI except for paragraphs IWV-3426 and IWV-3427 which are applicable. This is consistent with the NRC position described in GL-89-04, Attachment A, Item #10. Permissible leakage values for each category A or AC valve are listed in Attachment-"A".
- SLT-2A In lieu of the requirements of ASME Code Section XI, paragraphs IWV-3423 and IWV-3424, valves are seat leakage tested as part of the Appendix "J" containment isolation test by imposing a static head of water on the downstream side of the valve and verifying that the leakage within the specified value of Attachment "A" for each category valve. This testing method demonstrates that the containment spray and RHR Check Valve leakage over 30 days is limited to the water resident in the containment spray headers downstream of the check valves. The leakage specified would not deplete the water inventory so as to expose these valves to a post-LOCA environment for a minimum of 30 days in the event that a spray system must be shut down and drained. This testing method is as stated in Response to Question 22.15(5) of the original FSAR Appendix "Q", Amendment 81, dated August 1978.

DONALD C. COOK NUCLEAR PLANT

VALVE TEST PROGRAM

RELIEF REQUEST NOTES

Flow Diagram No: 1-5105D-1

Revision No: 3

Date: 2-5-90

NOTE 1: FW-118-1 thru -4 (Code Relief): These check valves are normally open during power operation to pass main feedwater flow to the steam generators. Their safety function (close) prevents auxiliary feedwater backflow into the main feedwater system. These valves cannot be exercised during power operation because closing of these valves would require securing feedwater flow to the steam generators. Main feedwater to the steam generators cannot be isolated on a loop basis because three loop operation is not allowed per Donald C. Cook Nuclear Plant Technical Specification 3.4.1.1. For these category "C" check valves, backflow cannot be quantified at cold shutdown due to system configuration. The only practical method to verify valve closure is by disassembly. Due to size, weight and close proximity to physical barriers (whip restraints); valve disassembly at cold shutdown would impose constraints on the manpower and scheduling that may delay essential cold shutdown related activities and the plant start-up. The valves are not equipped with position indicators. There has been no operational or maintenance adverse trend noted. Therefore, the valves will be disassembled (bonnet removed) and verified closed (disc against seat) on a sampling basis (one of four) at refueling outage frequency.

DONALD C. COOK NUCLEAR PLANT

VALVE TEST PROGRAM

RELIEF REQUEST NOTES

Flow Diagram No: 1-5105D-1

Revision No: 3

Date: 2-5-90

NOTE 2: MRV-210, -220, -230 and -240 (Cold Shutdown Justification): These steam generator stop valves cannot be full stroke exercised during power operation because this would require securing steam from a steam generator which could result in a reactor trip. Three loop operation is not allowed for D. C. Cook per Technical Specification 3.4.1.1. Valves MRV-211, -221, -231, -241, -212, -222, -232, and -242 which activate MRV-210, -220, -230, and -240 are tested quarterly in accordance with IWV-3410. MRV-210, -220, -230 and -240 are part stroke tested quarterly by use of hydraulics attached to valve operators. and full stroke tested during hot standby (Mode 3 with RCS temperature $\geq 541^{\circ}\text{F}$) at cold shutdown frequency.

NOTE 3: MS-108-2 and 108-3 (Code Relief): These check valves are located in the steam supply lines to the Auxiliary Feedwater Pump Turbine. These valves are part stroke tested during normal IST feedwater pump testing at least on a quarterly basis at approximately 700 gpm because flow is restricted to a maximum of approximately 700 gpm through the 3" test line used during pump test. The valves will be full stroke tested to open position at a cold shutdown frequency. The valve is not equipped with position indicator. In addition, due to the plant design, the only method available to verify the valve closure is disassembly. The valve will be disassembled (bonnet removed) and verified closed (disc against seat) and visually examined in accordance with GL-89-04, Attachment A, Item #2 on a sampling basis (one of two) once every other refueling frequency.

DONALD C. COOK NUCLEAR PLANT

VALVE TEST PROGRAM

RELIEF REQUEST NOTES

Flow Diagram No: 1-5106-35

Revision No: 3

Date: 2-5-90

NOTE 1: FMO-201, -202, -203, -204 & FRV-210, -220, -230, -240 (Cold Shutdown Justification): The function of these valves is to provide feedwater flow from the feedwater pumps to the steam generators. These valves cannot be exercised (part or full stroke) during power operation because closing these valves would require securing feed flow to the steam generator which may cause instability of steam generator water level which could result in reactor trip. Further, three loop operation is not allowed per Donald C. Cook Nuclear Plant Technical Specification 3.4.1.1. These valves will be full stroke exercised and timed during unit start-up or shutdown at cold shutdown frequency.

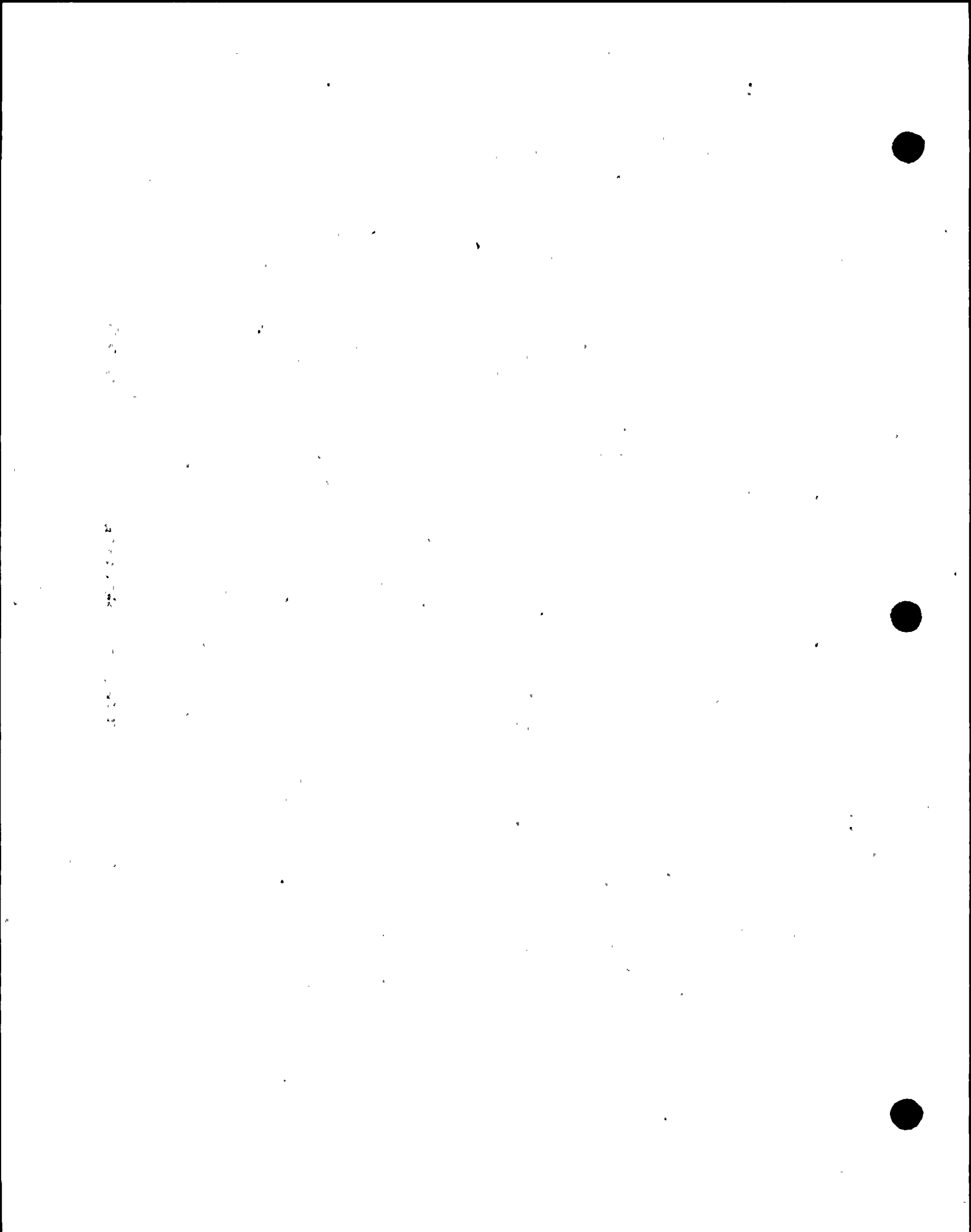

DONALD C. COOK NUCLEAR PLANT

VALVE TEST PROGRAM

RELIEF REQUEST NOTES

Flow Diagram No: 1-5106A-38

Revision No: 3

Date: 2-5-90

- NOTE 1: FW-132-1, -2, -3, -4 (Cold Shutdown Justification): These auxiliary feedwater (AFW) check valves function to supply AFW to the steam generators whenever the AFW System is caused to operate. These check valves cannot be full or partial stroke exercised during power operation without energizing the AFW System and delivering cold water to the steam generators. This would result in thermal shock to the steam generator nozzles. These valves are full stroke exercised during startup. The valves will be verified closed quarterly by monitoring temperature of Auxiliary Feed Line as required by the plant procedure during shift inspection tours.
- NOTE 2: FW-134 & FW-135 (Cold Shutdown Justification): These valves are located on the suction and discharge lines of the turbine driven auxiliary feedpump. The maximum flow rate through the turbine driven auxiliary feedpump during IST is approximately 700 gpm using the pump test line. Passing the design flow of 900 gpm through these valves would require delivering cold auxiliary feedwater to the steam generators. This would result in thermal shock to the steam generator nozzles. Therefore, these valves will be part stroke exercised quarterly and full stroke exercised (passing design flow of 900 gpm through the valves) at cold shutdown frequency.

DONALD C. COOK NUCLEAR PLANT

VALVE TEST PROGRAM

RELIEF REQUEST NOTES

Flow Diagram No: 1-5106A-38

Revision No: 3

Date: 2-5-90

- NOTE 3: FW-138-1, -2, -3, -4 (Cold Shutdown Justification): These auxiliary feedwater (AFW) check valves function to supply AFW to the steam generators whenever the AFW System is caused to operate. These check valves cannot be full or partial stroke exercised during power operation without energizing the AFW System and delivering cold water to the steam generators. This would result in thermal shock to the steam generator nozzles. The valves will be verified closed quarterly by monitoring temperature of Auxiliary Feed Line as required by the plant procedure during shift inspection tours. These valves are full stroke exercised when the plant is returned to power after cold shutdown.
- NOTE 4: FW-149 and 150 (Comment): The required full stroking of these check valves is satisfied when Turbine Driven Auxiliary Feedpump completes its required testing.
- NOTE 5: FW-153 and 160 (Comment): These check valves installed on the Emergency Leak Off (ELO) lines open when the Motor Driven Auxiliary Feedwater Pumps (MDAFP) start. This can be established when the MDAFP pump is operating through the test line. A pressure decrease in the pump discharge line is verified by a local pressure indicator when the parallel path ELO is opened. The pressure decrease indicates that flow is established through the ELO line and that the check valve is opened.

DONALD C. COOK NUCLEAR PLANT

VALVE TEST PROGRAM

RELIEF REQUEST NOTES

Flow Diagram No: 1-5113-41

Revision No: 3

Date: 2-5-90

NOTE 1: ESW-111, -112, -113, -114 (Comment): These valves are full stroke exercised quarterly as required by IWV-3520. In addition, they are disassembled and inspected internally in accordance with IEB 85-03 at refueling outage frequency.

NOTE 2: ESW-109, -115, -243 (Cold Shutdown Justification): These valves are normally closed and are required to be open when the condensate storage tank is exhausted. Exercising the valves could cause lake water contamination of the steam generators. Lake water chemistry can potentially impact steam generator tube integrity. Therefore, the valves will be full stroke tested at a cold shutdown frequency. Since the valves are manual, stroke timing is not required.

DONALD C. COOK NUCLEAR PLANT

VALVE TEST PROGRAM

RELIEF REQUEST NOTES

Flow Diagram No: 1-5113-41

Revision No: 3

Date: 2-5-90

NOTE 3: WRV-721, -723, -725, -727 (Code Relief): These valves are located in the essential service water supply lines to the emergency diesel generators air after coolers. These three-way valves regulate water flow to maintain the temperature at which the after cooler air discharge thermostatic controller has been set. Water flow is regulated by passing a portion of the flow through the air coolers and bypassing the excess flow around the air after coolers. Code relief is being requested from the testing requirements since (1), these valves function only as regulating valves and not open/closed valves (2), these valves are demonstrated operable during diesel generator testing (diesel generators are tested per Technical Specification 4.8.1.1.2); and (3), these valves are demonstrated operable during diesel generator 24 hour runs performed each refueling outage. The valves will be "fail-safe" tested using their control scheme that will remove air from the valve operators causing them to direct all ESW flow to the air after coolers. This proposed test for each valve will be performed at refueling frequency. The valves cannot be stroke timed because they are thermostatic valves whose position is controlled by process fluid temperature. There is no external control available.

DONALD C. COOK NUCLEAR PLANT

VALVE TEST PROGRAM

RELIEF REQUEST NOTES

Flow Diagram No: 1-5114A-31

Revision No: 3

Date: 2-5-90

NOTE 1: WCR-900 through -915, -920 through -935, -941 through 948, -951 through -958 and 960 through -967 (Code Relief):
See "Attachment-A" for permissible seat leakage values.

DONALD C. COOK NUCLEAR PL

VALVE TEST PROGRAM

RELIEF REQUEST NOTES

Flow Diagram No: 1-5124-21

Revision No: 3

Date: 2-5-90

NOTE 1: DCR-600 & -601 and NS-357 (Code Relief): See "Attachment-A" for permissible seat leakage values.

NOTE-2: NS-357 (Code Relief): This check valve is located on the return line of the post accident sampling system inside the containment. Since the line is open-ended inside the containment and the check valve is not equipped with the position indication, the valve will be full stroke exercised in the open position by performing a flow test quarterly and will be confirmed closed in conjunction with Appendix J seat leakage testing at refueling frequency.

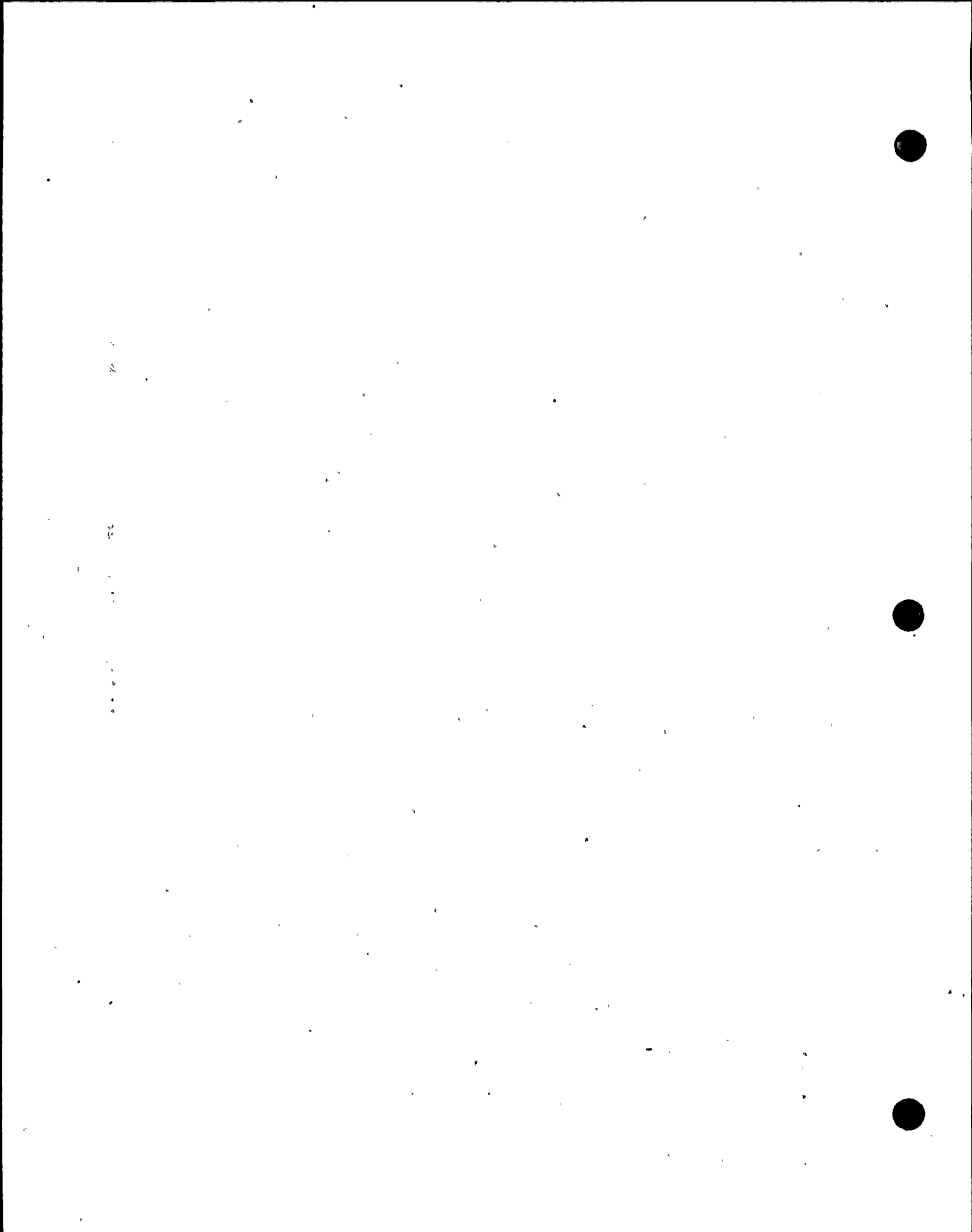

DONALD C. COOK NUCLEAR PLANT

VALVE TEST PROGRAM

RELIEF REQUEST NOTES

Flow Diagram No: 1-5128-19

Revision No: 3

Date: 2-5-90

NOTE 1: NSO-021, -022, -023, & -024 (Cold Shutdown Justification): These four one-inch solenoid operated isolation valves are installed (two in each leg in series) in the reactor head vent. These valves cannot be tested during power operation, hot standby, or hot shutdown because the valve design is such that testing of either valve can cause "burping" (momentary opening) of the second valve, resulting in the release of radioactive fluid and create an airborne situation in containment. Therefore, the valves will be full stroke exercised and timed at cold shutdown frequency.

Exercising the solenoid operated valves for verification of valve position (valve stem movement) will be performed at refueling frequency by a flow test through each valve because the valve stem is completely enclosed and cannot be observed. The reactor coolant discharged during the flow testing of the valves is collected in a container to minimize liquid contamination spill, radiation, and potential airborne situation in deference of ALARA consideration and personnel protection. The above tests are consistent with Technical Specification requirements.

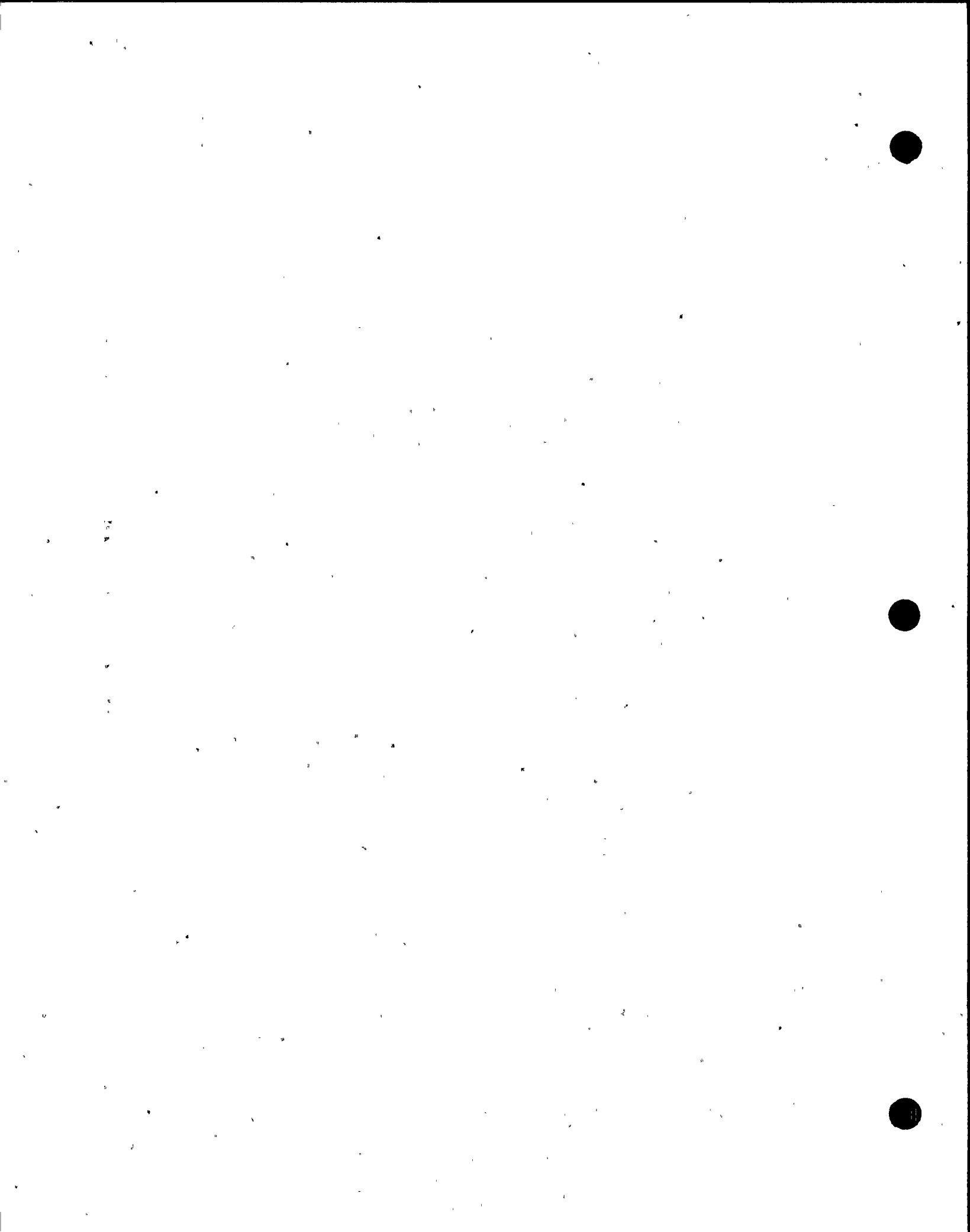

DONALD C. COOK NUCLEAR PLANT

VALVE TEST PROGRAM

RELIEF REQUEST NOTES

Flow Diagram No: 1-5128A-37

Revision No: 3

Date: 2-5-90

- NOTE 1: CS-442-1 thru 4 (Code Relief): These containment isolation check valves are on the seal water supply line to the RC pumps. These valves cannot be part or full stroke exercised to the closed position during power operation because cooling flow is required to the RCP seals. During cold shutdown, seal water must be maintained to prevent backflow through the seals with possible damage from dirt. The valves will be full stroke exercised in conjunction with Appendix J seat leakage testing at refueling frequency.
- NOTE 2: GCR-301, NCR-252, NPX-151, RCR-100 & -101, CS-442-1 through 4, SI-189, PW-275 and N-159 (Code Relief): See Attachment-"A" for permissible seat leakage values.
- NOTE 3: NRV-151, -152, -153 (Cold Shutdown Justification): These pressurizer power operated relief valves are normally closed during power operation. The valves cannot be exercised at power without inducing an RCS pressure transient which could result in reactor trip. The valves will be full stroke exercised and timed at cold shutdown frequency.

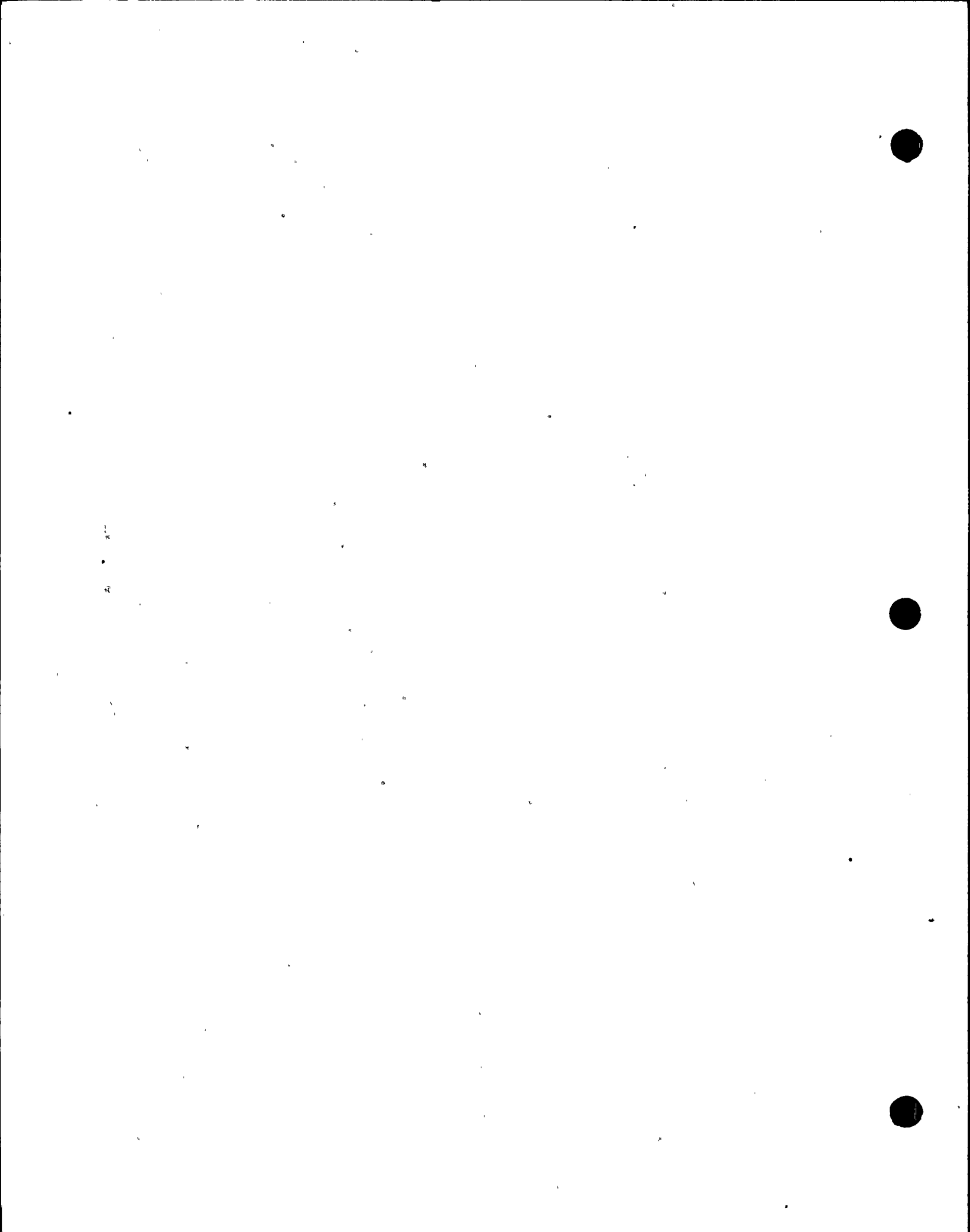

DONALD C. COOK NUCLEAR PLANT

VALVE TEST PROGRAM

RELIEF REQUEST NOTES

Flow Diagram No: 1-5128A-37

Revision No: 3

Date: 2-5-90

NOTE 4: PW-275 (Code Relief): This containment isolation check valve is located in the primary water supply line to the pressurizer relief tank. The valve is not equipped with position indication. The valve cannot be full stroke tested to closed position during power operation or at a cold shutdown frequency due to lack of sufficient differential pressure to back seat the valve. The valve and necessary test connections are located inside the containment. Due to the plant design, the only method available to verify the valve closure is leak testing. The valve will be verified closed in conjunction with Appendix J seat leakage testing at refueling frequency.

NOTE 5: N-159 (Code Relief): This containment isolation check valve is located in the nitrogen supply line to the pressurizer relief tank. The valve is not equipped with position indication. The valve cannot be full stroke tested to closed position during power operation or at a cold shutdown frequency due to lack of sufficient differential pressure to back seat the valve. The valve and necessary test connections are located inside the containment. Due to the plant design, the only method available to verify the valve closure is leak testing. The valve will be verified closed in conjunction with Appendix J seat leakage testing at refueling frequency.

DONALD C. COOK NUCLEAR PL

VALVE TEST PROGRAM

RELIEF REQUEST NOTES

Flow Diagram No: 1-5128A-37

Revision No: 3

Date: 2-5-90

NOTE 6: NSO-061, -062, -063, -064 (Cold Shutdown Justification): These four one-inch solenoid operated isolation valves are installed (two in each leg in series) in the pressurizer vent. These valves cannot be tested during power operation, hot standby, or hot shutdown because the valve design is such that testing of either valve can cause "burping" (momentary opening) of the second valve resulting in the release of radioactive fluid and create an airborne situation in containment. The valves will be full stroke tested and timed at cold shutdown frequency.

Exercising the solenoid operated valves for verification of valve position (valve stem movement) will be performed at refueling frequency by performing a flow test through each valve because the valve stem is completely enclosed and cannot be observed. The reactor coolant discharged during flow testing of the valves is collected in a container to minimize contaminated liquid spill, radiation, and potential airborne situation in deference of ALARA consideration and personnel protection. The above tests are consistent with Technical Specification requirements.

DONALD C. COOK NUCLEAR PL

VALVE TEST PROGRAM

RELIEF REQUEST NOTES

Flow Diagram No: 1-5128A-37

Revision No: 3

Date: 2-5-90

NOTE 7: SI-189 (Code Relief): This check valve is located in the safety valves discharge (Emergency Core Cooling SVs, RHR, SVs, centrifugal charging pump SVs, etc.) collection header leading to the pressurizer relief tank. Isolating this valve for testing would result in dead heading all safety valves in the above systems. This would result in loss of overpressurization protection and could put the plant in an unsafe condition. Therefore, the valve will be part stroke exercised to open position using external source via test connection at a cold shutdown frequency. The valve will be disassembled, manually full stroke tested and visually examined in accordance with GL-89-04, Attachment 1, Item #2 at every third refueling outage frequency. The valve will also be verified closed in conjunction with Appendix J seat leakage testing at refueling frequency.



1
2
3
4
5
6
7
8
9
10
11
12
13
14
15
16
17
18
19
20
21
22
23
24
25
26
27
28
29
30
31
32
33
34
35
36
37
38
39
40
41
42
43
44
45
46
47
48
49
50
51
52
53
54
55
56
57
58
59
60
61
62
63
64
65
66
67
68
69
70
71
72
73
74
75
76
77
78
79
80
81
82
83
84
85
86
87
88
89
90
91
92
93
94
95
96
97
98
99
100

DONALD C. COOK NUCLEAR PLANT

VALVE TEST PROGRAM

RELIEF REQUEST NOTES

Flow Diagram No: 1-5129-31

Revision No: 3

Date: 2-5-90

NOTE 1: CS-292 (Code Relief): This valve is in the emergency boration path from the boric acid system to the charging pump suction header. Flow through this path is normally not provided at power because of the resultant large negative reactivity insertion. The valve will be full stroke exercised in the open position at a cold shutdown frequency. The check valve is not equipped with position indication. Due to the plant design, the only methods available to verify the valve closure is either radiography or disassembly which will be performed at a refueling frequency when the system is not required to be operable. The radiography method is an acceptable method to verify the valve closure (disc against the seat) under no flow condition because it provides visual observation of the valve in the closed position. The flow testing of the valve verifies that it is open. This provides assurance that the disc is free to move from the open position with flow to the closed position with no flow or reverse flow.

NOTE 2: CS-299E, -299W (Code Relief): These check valves located on the discharge lines of the 'E' and 'W' charging pumps function as pressure isolation valves to protect the low pressure charging pump suction lines. These valves cannot be full-stroke exercised during: (1) power operation because the charging pumps cannot achieve maximum flow rate with the reactor at full pressure, and (2) cold shutdown because the flow required could cause a low temperature overpressure condition. The valves will be part-stroke exercised quarterly and full stroke exercised at refueling frequency. The valves will also be verified closed in conjunction with seat leakage testing per IWV-3420 at refueling frequency.

DONALD C. COOK NUCLEAR PLANT

VALVE TEST PROGRAM

RELIEF REQUEST NOTES

Flow Diagram No: 1-5129-31

Revision No: 3

Date: 2-5-90

- NOTE 3: CS-321, QCR-300 and -301 (Code Relief): See Attachment "A" for permissible seat leakage values.
- NOTE 4: CS-321 (Code Relief): This containment isolation check valve's function is to supply borated water from the volume control tank to the regenerative heat exchanger through the charging pumps for chemical shim control and reactor coolant system makeup. Isolation of this system would result in loss of control of pressurizer level which could result in reactor trip. This valve is tested in the open direction quarterly and confirmed closed in conjunction with Appendix J seat leakage testing at refueling frequency.
- NOTE 5: CS-328L1, -329L1, -328L4, -329L4 (Comment): These check valves function to provide the interface point between the RCS and the CVCS. Since the discharge piping of the CVCS is designed to a pressure rating higher than the RCS, these valves do not perform a pressure isolation function. The higher pressure (RCS) to low pressure (CVCS Suction) isolation is accomplished by other valves which are tested to category "A" requirements. The valves will be full stroke exercised to open position quarterly.
- NOTE 6: QCR-300, -301 (Cold Shutdown Justification): These air operated containment isolation valves are located on the letdown return line. Exercising these valves during power operation would result in letdown isolation which could result in loss of pressurizer level control which could result in a plant shutdown. The valves will be full stroke exercised, timed and fail safe tested at a cold shutdown frequency and seat leakage tested per Appendix J program at refueling frequency.

DONALD C. COOK NUCLEAR PLANT

VALVE TEST PROGRAM

RELIEF REQUEST NOTES

Flow Diagram No: 1-5129-31

Revision No: 3

Date: 2-5-90

- NOTE 7: QMO-200, -201 (Cold Shutdown Justification): These motor operated gate valves are installed on the CVCS charging line which provide borated water for RCS chemical shim control and reactor coolant system makeup. Isolation of this system would result in loss of control of pressurizer level which could result in reactor trip. The valves will be full stroke tested and timed at cold shutdown frequency.
- NOTE 8: QRV-200 (Code Relief): This air operated valve is used to regulate charging header flow to the reactor coolant system and seal water flow to the reactor coolant pump seals. The valve cannot be full stroke exercised at power operation because it would interrupt the seal injection flow to the reactor coolant pumps which could result in reactor coolant pump seal damage. The valve will be part stroke exercised during power operation and full stroke exercised at a cold shutdown frequency. The valve cannot be stroke timed because there is no local or remote position indicator available and cycle times are directly proportional to "how fast" the operator turns the control knob. Therefore, meaningful stroke times are not achievable. This valve has no fail safe position. The alternative testing proposed is to locally observe the valve during full stroke testing for smooth operation and apparent problems which can affect the valve operation.

DONALD C. COOK NUCLEAR PLANT

VALVE TEST PROGRAM

RELIEF REQUEST NOTES

Flow Diagram No: 1-5129-31

Revision No: 3

Date: 2-5-90

NOTE 9: QRV-251 (Code Relief): This air operated valve is used to regulate charging header flow to the reactor coolant system and seal water flow to the reactor coolant pump seals. The valve cannot be full stroke exercised at power operation because it would interrupt the RCP seal injection flow and would also upset pressurizer level. The valve will be part stroke exercised during power operation and full stroke exercised at a cold shutdown frequency. The valve cannot be stroke timed because there is no local or remote position indicator available and cycle times are directly proportional to "how fast" the operator can turn the control knob. Therefore, meaningful stroke times are not achievable. The control scheme of this valve functions to remove air from the valve operator, which duplicates the fail-safe condition, resulting in the valve going to fail-safe (open) position. Therefore, the alternative testing proposed will consist of locally observing the valve during full stroke testing for smooth operation and apparent problems which can affect the valve operation.

NOTE 10: SI-185 (Code Relief): This normally closed valve functions to transfer the suction source of the charging pumps to the refueling water storage tank. This valve cannot be full stroke exercised during: (1) power operation without introducing a high concentration of boric acid in the RCS, and (2) cold shutdown because the only full flow path available is into the reactor coolant system and the system does not have sufficient volume to accommodate that flow without a possible low temperature overpressure condition. The valve will be full stroke exercised at refueling frequency.

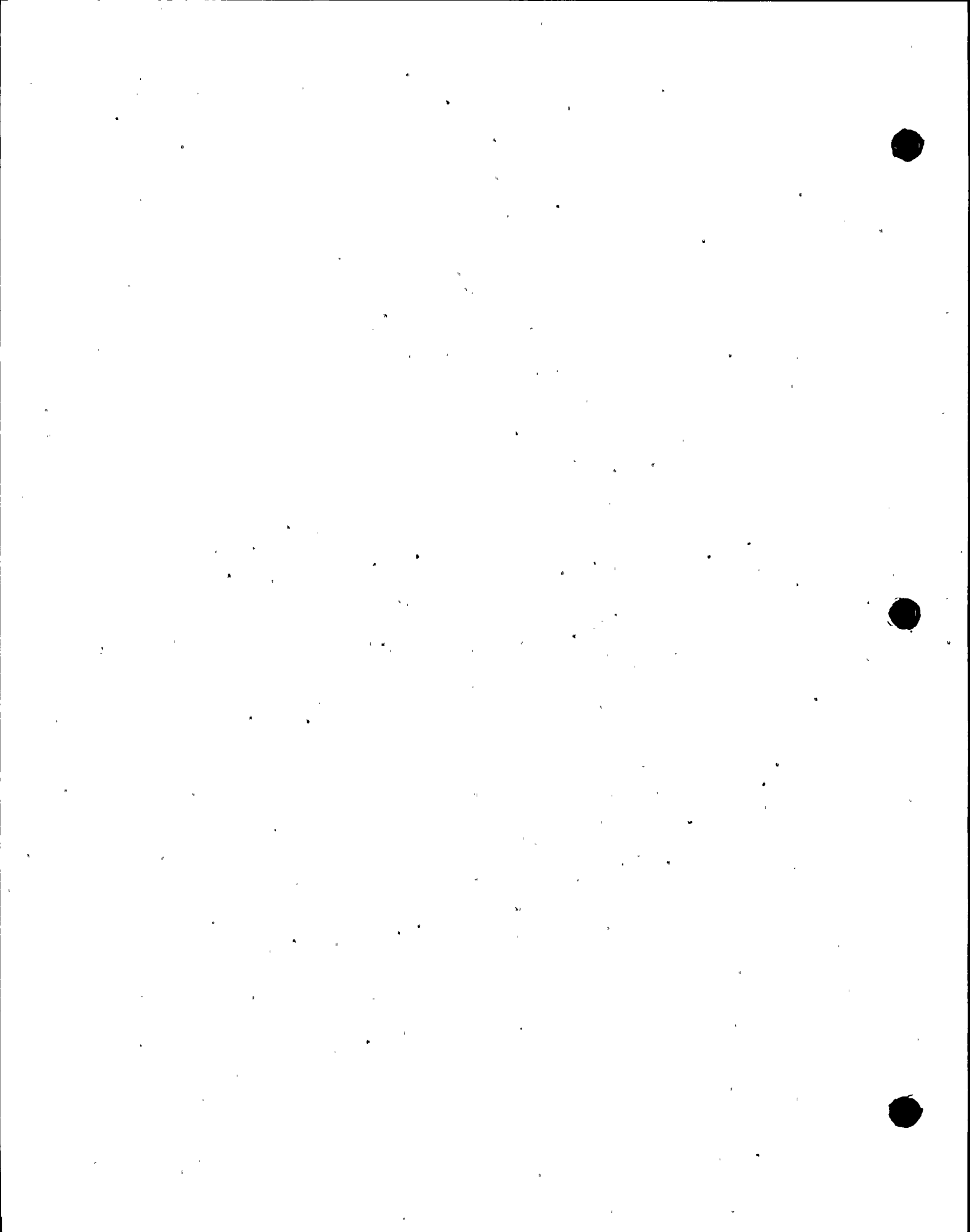

DONALD C. COOK NUCLEAR PLANT

VALVE TEST PROGRAM

RELIEF REQUEST NOTES

Flow Diagram No: 1-5129-31

Revision No: 3

Date: 2-5-90

NOTE 11: CS-299E&W (Comment): See Attachment "A" for permissible seat leakage values.

DONALD C. COOK NUCLEAR PLANT

VALVE TEST PROGRAM

RELIEF REQUEST NOTES

Flow Diagram No: 1-5129A-19

Revision No: 3

Date: 2-5-90

- NOTE 1: QCM-250, -350 (Cold Shutdown Justification): These motor-operated reactor coolant pump seal water return isolation valves cannot be exercised during power operation because it would interrupt reactor coolant pump seal water flow and could cause damage to the seals. Therefore, the valves are full stroke exercised and timed at cold shutdown frequency.
- NOTE 2: QCM-250 and -350 (Code Relief): See "Attachment-A" for permissible seat leakage values.
- NOTE 3: QMO-451, -452 (Cold Shutdown Justification): These motor-operated gate valves function as volume control tank isolation valves. Exercising these valves during power operation could result in a loss of pressurizer level control which could cause a reactor trip. These valves are full stroke exercised and timed at cold shutdown frequency.

DONALD C. COOK NUCLEAR PLANT

VALVE TEST PROGRAM

RELIEF REQUEST NOTES

Flow Diagram No: 1-5135-29

Revision No: 3

Date: 2-5-90

- NOTE 1: CCM-451, -452, -453, -454, -458 and -459 (Cold Shutdown Justification): These valves cannot be tested during power operation without securing cooling water to the reactor Coolant Pumps (RCPs). Isolation of these valves could cause failure of the RCPs. The valves will be full stroke tested and timed at cold shutdown frequency.
- NOTE 2: CCM-451 through -454, -458, -459
CCR-455 through -457, -460, -462 and CCW-135 (Code Relief):
See "Attachment-A" for permissible seat leakage values.
- NOTE 3: CCR-455, -456, and -457 (Cold Shutdown Justification): These valves cannot be tested during power operation without securing cooling water to the reactor support coolers. These valves must remain open to prevent overheating of the concrete around the reactor supports during power operation. The valves will be full stroke tested and timed at cold shutdown frequency.
- NOTE 4: CCW-135 (Code Relief): This check valve cannot be tested during power operation without securing cooling water to the reactor support coolers. The valve must remain open to prevent overheating of the concrete around the reactor supports during power operation. The valve will be verified closed in conjunction with Appendix J seat leakage testing at refueling frequency.
- NOTE 5: CRV-470 (Code Relief): This air operated valve is used to regulate component cooling water (CCW) to the letdown heat exchanger. The valve is normally in service during power operation.

DONALD C. COOK NUCLEAR PLANT

VALVE TEST PROGRAM

RELIEF REQUEST NOTES

Flow Diagram No: 1-5135-29

Revision No: 3

Date: 2-5-90

CRV-470 (continued)

This valve is controlled by an auto/manual station with auto input from the letdown heat exchanger outlet temperature sensor (QTC-302). The valve also trips closed from an SI signal via a solenoid valve. The valve will be full stroke exercised quarterly using auto/manual station which will permit rapid cycling of this regulating valve resulting in minimal impact on letdown temperature. Meaningful stroke time data is not available since this valve does not have local or remote position indication.

Fail safe testing this valve closed requires a longer period of time than cycling the valve using the auto/manual station. The valve will be fail safe tested to its closed position at cold shutdown frequency with letdown flow out of service thus avoiding high letdown line temperatures that could cause flashing in the letdown heat exchanger and lifting of safety valves.

DONALD C. COOK NUCLEAR PLANT

VALVE TEST PROGRAM

RELIEF REQUEST NOTES

Flow Diagram No: 1-5135A-30

Revision No: 3

Date: 2-5-90

NOTE 1: CCW-170 (Comment): This valve will be tested in accordance with IWV-3416 whenever the spare CCW pump is placed in service.

NOTE 2: CMO-411, -412, -413, -414, -415 & -416 (Comment): These valves remain open during initial safety injection, but may be closed during recirculation phase or passive failure. Therefore, the valve time will be recorded from open to close position.

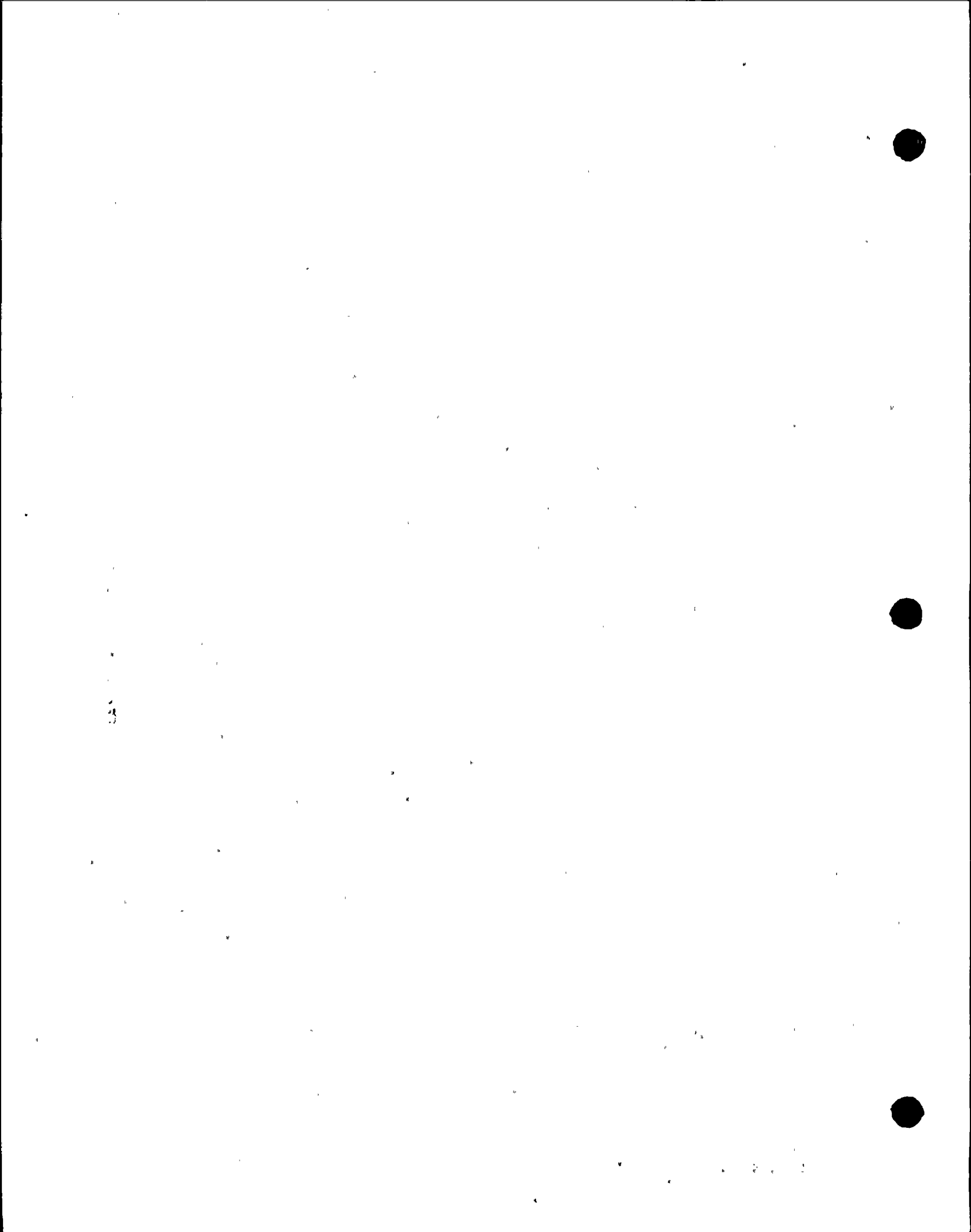

DONALD C. COOK NUCLEAR PLANT

VALVE TEST PROGRAM

RELIEF REQUEST NOTES

Flow Diagram No: 1-5135B-14

Revision No: 3

Date: 2-5-90

NOTE 1: CCM-430 through -433, CCR-440 and -441; CCW-243-25, -243-72, -244-25 and -244-72 (Code Relief): See "Attachment-A" for permissible seat leakage values.

NOTE 2: CCW-243-25, CCW-243-72, CCW-244-25 and CCW-244-72 (Code Relief): These check valves are located in the penetration cooling supply headers of the CCW System inside the containment. The valves are open during power operation and cold shutdown to provide cooling water to the main steam penetrations. These valves are not equipped with position indication. The valves will be confirmed closed in conjunction with Appendix J seat leakage testing at refueling frequency.

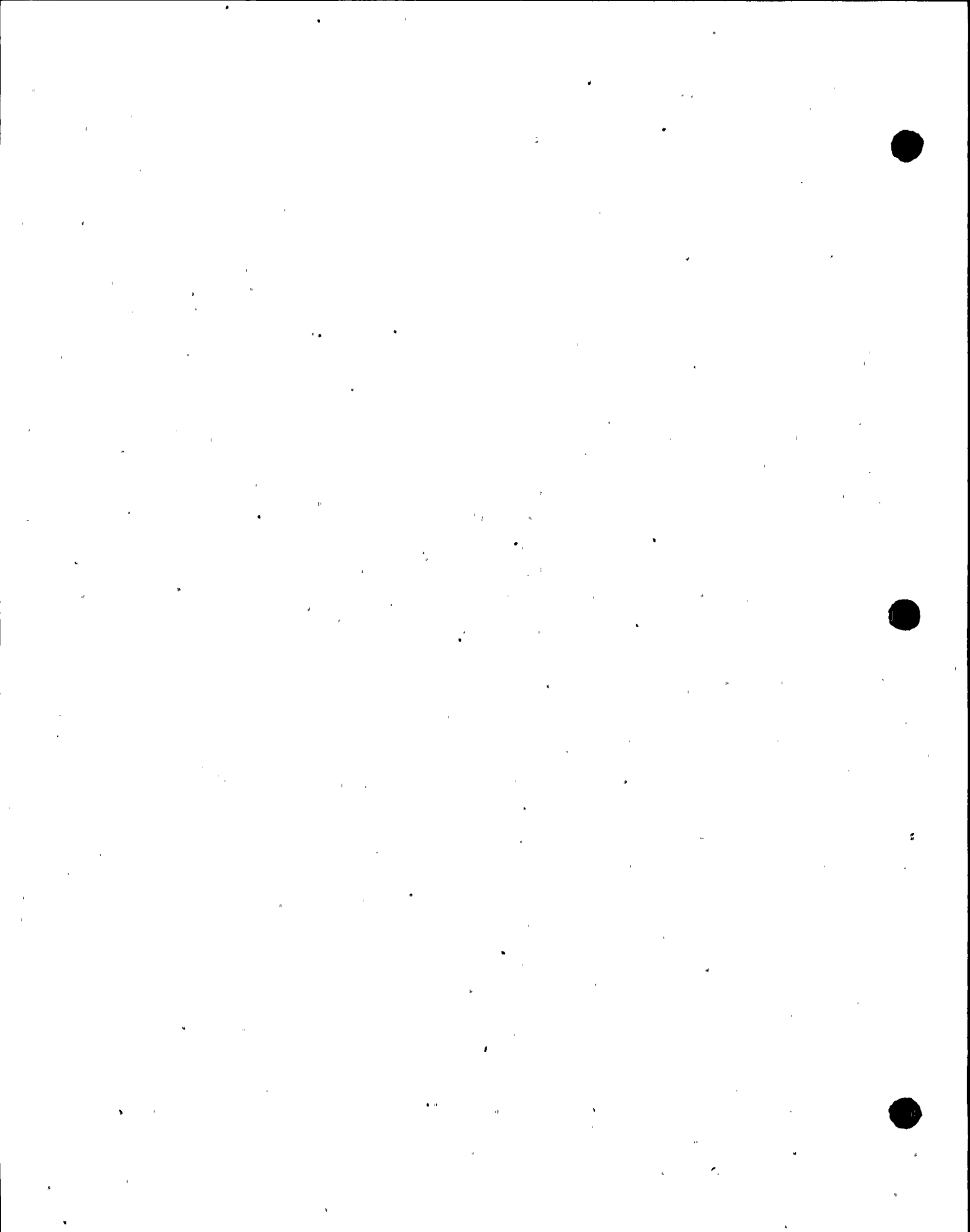

DONALD C. COOK NUCLEAR PLANT

VALVE TEST PROGRAM

RELIEF REQUEST NOTES

Flow Diagram No: 1-5141-29

Revision No: 3

Date: 2-5-90

NOTE 1: ICR-5, -6, NCR-105 through -110 (Code Relief): See "Attachment-A"
for permissible seat leakage values.

DONALD C. COOK NUCLEAR PLANT

VALVE TEST PROGRAM

RELIEF REQUEST NOTES

Flow Diagram No: 1-5141D-10

Revision No: 3

Date: 2-5-90

NOTE 1: ECR-10 through -29 and NS-283 (Code Relief): See "Attachment-A" for permissible seat leakage values.

NOTE 2: NS-283 (Code Relief): This containment isolation check valve is located in the sample return line of the Post-Accident Containment Hydrogen Monitoring System. The valve cannot be full stroke exercised to closed position quarterly or at a cold shutdown frequency because the line is open ended in the containment. This check valve is not equipped with position indicator. The only method available to verify the valve closure is by seat leakage testing. The valve will be full stroke exercised to the open position by a flow test quarterly and will be confirmed closed in conjunction with Appendix J seat leakage testing at refueling frequency.

DONALD C. COOK NUCLEAR PLANT

VALVE TEST PROGRAM

RELIEF REQUEST NOTES

Flow Diagram No: 1-5142-25

Revision No: 3

Date: 2-5-90

- NOTE 1: ICM-250 and ICM-251 (Cold Shutdown Justification): These normally closed valves cannot be operated during normal plant operation without introducing Boron into a nonheat traced line. Boron could crystallize and plug the line. The valves will be full stroke tested and timed at cold shutdown frequency.
- NOTE 2: ICM-250, -251, -260 and -265 (Code Relief): See "Attachment-A" for permissible seat leakage values.
- NOTE 3: IMO-261 (Cold Shutdown Justification): This valve cannot be tested when SI pumps are required to be operable. Testing would result in isolation of the common suction line to both SI trains. This valve will be stroke tested and timed at cold shutdown frequency.
- NOTE 4: IMO-262 and -263 (Cold Shutdown Justification): These motor operated valves are located in series in the re-circulation line of the Safety Injection pumps. Exercising either of these valves will make both SI pumps inoperable. These valves will be full-stroke exercised and timed at cold shutdown frequency when SI pumps are not required to be operable.
- NOTE 5: SI-110N, SI-110S and SI-101 (Code Relief): Safety Injection (SI) pump discharge valves, SI-110N and -110S, cannot be exercised during power operation because the SI pumps cannot overcome reactor coolant system pressure. Therefore, no flow path exists and, because minimum flow lines branch off upstream of these valves, they cannot be part-stroke tested during pump testing. The common (SI pumps) suction check valve, SI-101 is part-stroke exercised at

DONALD C. COOK NUCLEAR PLANT

VALVE TEST PROGRAM

RELIEF REQUEST NOTES

Flow Diagram No: 1-5142-25

Revision No: 3

Date: 2-5-90

Note 5 (continued)

power operation during pump testing. These valves cannot be exercised during cold shutdown because the SI pumps are required to be inoperable by Technical Specification 3.5.3 to protect against low temperature overpressurization of the reactor. These valves will be full-stroke exercised at refueling frequency.

NOTE 6: SI-142 L1, L2, L3, and L4 (Code Relief): These check valves are located in the supply lines from the Boron Injection Tank to the reactor coolant cold legs (loop 1 through 4). These valves cannot be tested during power operation because this would require injecting highly concentrated boric acid solution from the Boron Injection Tank into the Reactor Coolant System resulting in probable plant shutdown.

These valves cannot be partially-stroke exercised using the BIT bypass line because this could result in bypassing the BIT, thereby not achieving design flow through the BIT if an accident occurred.

These valves cannot be full-stroked exercised during cold shutdown because this would require injecting the BIT into the RCS which could significantly delay startup from cold shutdown condition (the BIT would have to be brought to the proper Boron concentration and the RCS would have to be diluted sufficiently to allow startup). These valves will be full stroke exercised at refueling frequency.

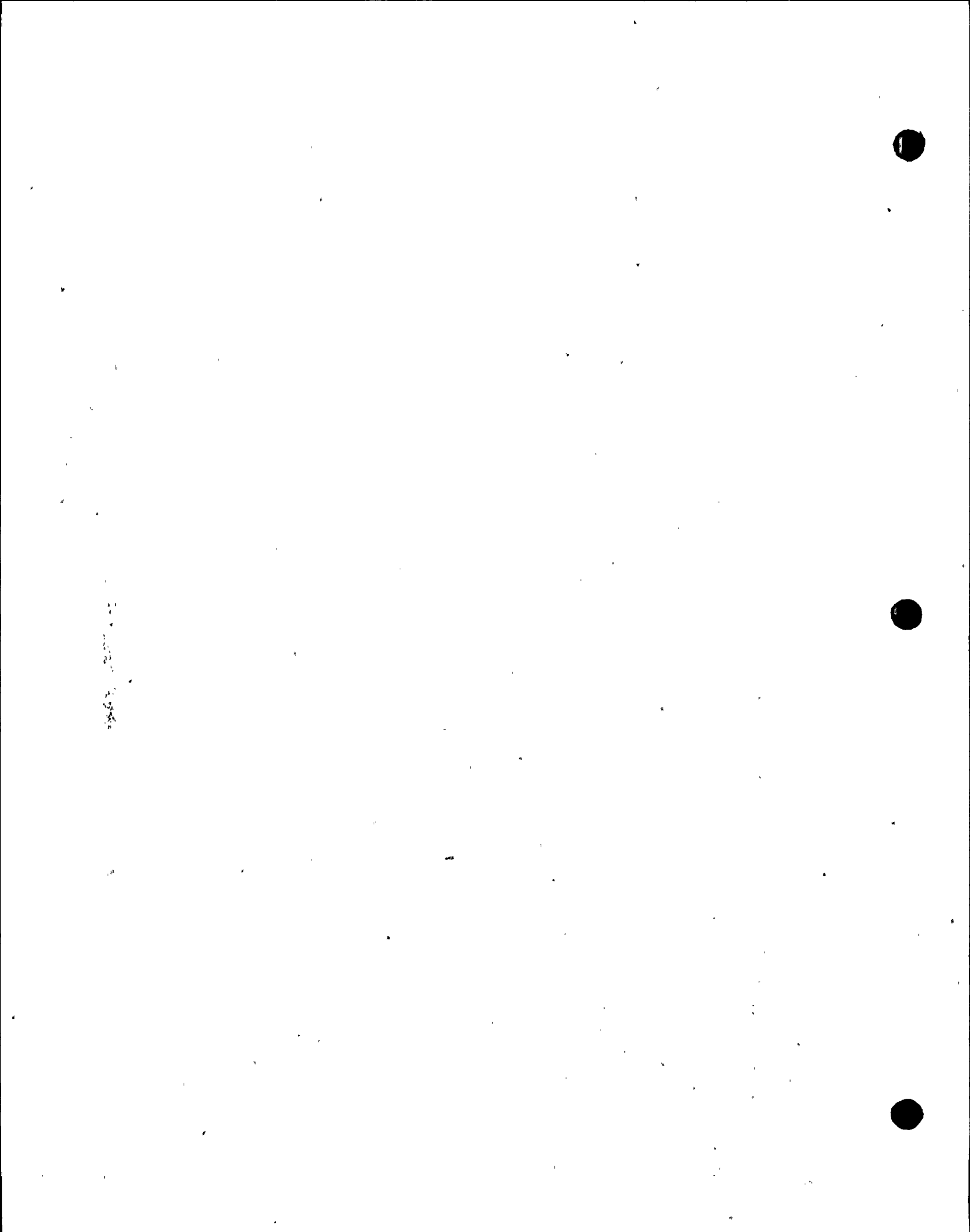

DONALD C. COOK NUCLEAR PLANT

VALVE TEST PROGRAM

RELIEF REQUEST NOTES

Flow Diagram No: 1-5143-36

Revision No: 3

Date: 2-5-90

- NOTE 1: SI-151E&W, -152N&S, -158-L1 through L4, -161-L1 through L4, -166-1 through 4, -170L1 through L4, RH-133, -134 and ICM-129 (Comment): See "Attachment-A" for permissible seat leakage values.
- NOTE 2: IMO-128 and ICM-129 (Cold Shutdown Justification): These valves function as the normal return from the RCS to the RHR for heatup and cooldown. These valves are normally closed and cannot be operated during normal plant operation because they are interlocked to remain closed at RCS pressure above 450 psig. The valves will be full stroke exercised and timed prior to placing them into service at cold shutdown frequency.
- NOTE 3: IMO-310, -320, -314, -324 (Comment): These valves remain open during injection phase of a safety injection, but will be closed during recirculation phase. Therefore, stroke timing will be from open to close position.
- NOTE 4: IMO-315, -316, -325, -326 (Cold Shutdown Justification): Valves IMO-315 and -325 are normally closed valves, located in the RHR and SI Supply Header to RCS hot legs. Valves IMO-316 and -326 are normally open valves located in the RHR and SI Supply Header to RCS cold legs. These valves should not be exercised during power operation because failure in a non-conservative position would result in less than minimum number of injection flow path as required by the FSAR. The valves will be full stroke tested and timed at cold shutdown frequency.

DONALD C. COOK NUCLEAR PLANT

VALVE TEST PROGRAM

RELIEF REQUEST NOTES

Flow Diagram No: 1-5143-36

Revision No: 3

Date: 2-5-90

NOTE 5: SI-166-1 through 4 (Code Relief): These check valves function to prevent backflow from the RCS into the accumulators during normal operation. These valves function to supply flow from the accumulators to the RCS during an accident condition. These valves cannot be exercised during power operation because the accumulators do not have sufficient head to overcome RCS pressure.

These valves cannot be exercised during cold shutdown because this would result in a possible low temperature overpressurization of the RCS. Full stroke testing during refueling outages is not possible because of the resulting water surge into the reactor and the potential for high airborne radiation contamination. These valves will be part stroke exercised at refueling frequency. The valves will be disassembled, manually full stroke exercised and visually examined on a sampling basis (one of four) per GL-89-04, Attachment 1, Item #2, at refueling frequency.

NOTE 6: SI-161, L1, L2, L3, L4 (Code Relief): These check valves are located in the supply lines from the Residual Heat Removal and Safety Injection Pumps to the RCS cold legs (loop 1 through 4). These valves cannot be exercised during power operation because the RHR pumps and SI pumps do not develop sufficient head to overcome RCS pressure. Full stroke of these valves (individually) cannot be verified at cold shutdown frequency because flow instrumentation is not available downstream of the flow split. These valves will be part stroke exercised at cold shutdown frequency and full stroke will be locally verified using portable instrumentation at refueling frequency.

2



10/10/10

DONALD C. COOK NUCLEAR PLANT

VALVE TEST PROGRAM

RELIEF REQUEST NOTES

Flow Diagram No: 1-5143-36

Revision No: 3

Date: 2-5-90

- NOTE 7: RH-108E,W (Cold Shutdown Justification): These valves cannot be full stroke exercised quarterly because it would require design modification to existing instrumentation to accommodate the full flow test measurements. The valves will be part stroke exercised quarterly and full stroke exercised at cold shutdown frequency (during RHR operation).
- NOTE 8: SI-148 (Code Relief): Check valve SI-148 is located in the Refueling Water Storage Tank (RWST) supply line to the RHR system. The design flow through the valve is 6000 gpm. Flow to the core is not possible when the RCS pressure is above the shut-off pressure of the RHR pumps (195 psig). In order to full stroke exercise this valve, both RHR pumps must be operated and the RHR system manually aligned to recirculate flow back to the RWST. This configuration places both RHR trains inoperable since neither train can provide design flow to the core. In order to preclude placing the unit in an unsafe condition, a partial stroke test is performed quarterly. The valve cannot be full stroke exercised during cold shutdown since the RCS cannot accommodate the introduction of 6000 gpm from the RHR system. In addition, during cold shutdown, the RHR system is required to be operable for RCS temperature control. The valve will be full stroke exercised when the reactor cavity is being flooded at refueling frequency.
- NOTE 9: SI-151 E, W (Cold Shutdown Justification): These check valves are located in the RHR supply lines to either the hot or cold legs. These valves cannot be exercised during power operation because the RHR pumps do not develop sufficient head to overcome RCS pressure. These valves will be exercised at cold shutdown frequency.

DONALD C. COOK NUCLEAR PLANT

VALVE TEST PROGRAM

RELIEF REQUEST NOTES

Flow Diagram No: 1-5143-36

Revision No: 3

Date: 2-5-90

NOTE 10: SI-152 N, S (Code Relief): These check valves function to provide Safety Injection pump discharge to either the hot or cold legs. These valves cannot be exercised during power operation because the SI pumps do not develop sufficient pressure to overcome RCS pressure. These valves cannot be exercised during cold shutdown because the safety injection pumps are required to be inoperable by Technical Specification Section 3.5.3, to protect against low temperature overpressurization of the reactor vessel. Also, during cold shutdown, there may not be sufficient volume in the RCS to accommodate the amount of water needed to full stroke. These valves will be full stroke exercised at refueling frequency.

NOTE 11: SI-158 L1, L2, L3, L4 (Code Relief): Check valves SI-158 are located in the supply lines from the Residual Heat Removal and Safety Injection Pumps to the RCS hot legs (loop 1 through 4). These valves cannot be exercised during power operation because the RHR and SI pumps do not develop sufficient head to overcome RCS pressure. Full stroke of these valves (individually) cannot be verified at cold shutdown frequency because flow instrumentation is not available downstream of the flow split. These valves will be part stroke exercised at cold shutdown frequency. Full stroke will be verified using portable instrumentation at refueling frequency.

DONALD C. COOK NUCLEAR PLANT

VALVE TEST PROGRAM

RELIEF REQUEST NOTES

Flow Diagram No: 1-5143-36

Revision No: 3

Date: 2-5-90

- NOTE 12: SI-170 L1, L2, L3, and L4 (Code Relief): These valves are located on the RCS cold leg (loops 1 through 4) injection lines from the accumulators, RHR, and SI systems. They cannot be exercised during power operations because the RHR and SI pumps do not develop sufficient head to overcome RCS pressure. The valves will be part-stroke exercised at a cold shutdown frequency. Due to the plant design, the valves are sized such that full stroke testing cannot be attained without discharging the accumulators and operating SI and RHR pumps simultaneously. The only method available to verify the full stroke is by disassembly. The valves are not equipped with position indicators. The valves will be disassembled, manually full stroke exercised and visually examined on a sampling basis (one of four) per GL-89-04, Attachment 1, Item #2; at refueling frequency.
- NOTE 13: N-102 (Code Relief): This check valve is located in the nitrogen supply header to the accumulators for blanketing purposes. The valve cannot be full stroke tested to the closed position during power operation or cold shutdown because, due to the plant design, the only method available to verify the valve closure is leak testing. The valve and necessary test connections are located inside the containment. The valve is not equipped with a position indicator. The valve will be verified closed in conjunction with Appendix J seat leakage testing at refueling frequency.
- NOTE 14: GCR-314, ICM-305 and -306, N-102, SI-171, -172 and -194 (Code Relief): See "Attachment-A" for permissible seat leakage values.

DONALD C. COOK NUCLEAR PLANT

VALVE TEST PROGRAM

RELIEF REQUEST NOTES

Flow Diagram No: 1-5143-36

Revision No: 3

Date: 2-5-90

NOTE 15: IMO-340 and -350 (Code Relief): Valves IMO-340 and IMO-350 are located in east and west RHR discharge headers to the suction of charging and SI pumps, respectively. These valves are normally closed during power operation, and would be opened during the recirculation phase of a LOCA to allow the RHR pumps to provide water from the containment recirculation sump to charging and SI pumps. These valves cannot be full stroke exercised during power operation because they are interlocked with valves IMO-262 and -263, located in series, in the SI pump miniflow (recirculation) line to RWST. Closing of IMO-262 and -263 would render both SI pumps inoperable and, thus, places the unit in T/S 3.0.3, which allows one hour to restore the SI pumps to operable status or begin a unit shutdown. The complicated valve and equipment lineup to perform the valve testing in one hour is highly unlikely. Therefore, the valves will be full stroke exercised and timed on a cold shutdown frequency. (For additional details, refer to Code Relief granted by the NRC dated 1-30-89, AEP:NRC:09690.)

DONALD C. COOK NUCLEAR PLANT

VALVE TEST PROGRAM

RELIEF REQUEST NOTES

Flow Diagram No: 1-5144-28

Revision No: 3

Date: 2-5-90

NOTE 1: CTS-138E & W (Code Relief): These check valves are located in the lines which supply water from the RWST to the containment spray pumps. The valves cannot be full stroke exercised during power operation, cold shutdown or refueling without spraying the containment. The valves are part stroke exercised during containment spray pump testing on a quarterly basis. The only practical method available to verify full stroke of these valves is by disassembly. These valves are not equipped with position indicators. The valves will be disassembled, manually full stroke exercised and visually examined on a sampling basis (one of two) per GL-89-04, Attachment 1, Item #2, once every other refueling frequency.

NOTE 2: CTS-103 E & W (Code Relief): These check valves are located in the discharge lines of containment spray pumps to the spray ring headers in the containment. These valves cannot be full stroke exercised during power operation, cold shutdown or refueling without spraying the containment. The valves are part stroke exercised during containment spray pump testing on a quarterly basis. The only practical method available to verify full stroke of these valves is by disassembly. The valves are not equipped with position indicators. The valves will be disassembled, manually full stroke exercised and visually examined on a sampling basis (one of two) per GL-89-04, Attachment 1, Item #2, once every other refueling frequency.

DONALD C. COOK NUCLEAR PLANT

VALVE TEST PROGRAM

RELIEF REQUEST NOTES

Flow Diagram No: 1-5144-28

Revision No: 3

Date: 2-5-90

NOTE 3: CTS-131E & W (Code Relief): These check valves are located in the supply lines to the (upper compartment) containment spray ring headers. These valves are in closed position during normal plant operation. The valves are exposed to containment atmosphere on the downstream side and are isolated from fluid pressure in the upstream side by the closed motor operated valves. The valves cannot be part or full stroke exercised during power operation, cold shutdown or refueling because flow through these valves would result in spraying the containment. This could cause problems with wet lagging, corrosion of components inside the containment, etc. The only practical method available to exercise these valves is by disassembly. The valves are not equipped with position indicators. The valves will be disassembled, manually full stroke exercised and visually examined on a sampling basis (one of two) per GL-89-04, Attachment 1, Item #2, once every other refueling frequency.

NOTE 4: CTS-127E & W (Code Relief): These check valves are located in the supply lines to the (lower compartment) containment spray ring headers. These valves are in closed position during normal plant operation. The valves are exposed to containment atmosphere on the downstream side and are isolated from fluid pressure in the upstream side by the closed motor operated valves. The valves cannot be part or full stroke exercised during power operation, cold shutdown or refueling because flow through these valves would result in spraying the containment. This could cause problems with wet lagging, corrosion of components inside the containment, etc. The only practical method available to exercise these valves is by

DONALD C. COOK NUCLEAR PLANT

VALVE TEST PROGRAM

RELIEF REQUEST NOTES

Flow Diagram No: 1-5144-28

Revision No: 3

Date: 2-5-90

Note 4 (continued)

disassembly. The valves are not equipped with position indicators. The valves will be disassembled, manually full stroke exercised and visually examined on a sampling basis (one of two) per GL-89-04, Attachment 1, Item #2, once every other refueling frequency.

NOTE 5: RH-141 & -142 (Code Relief): These check valves are located in the supply lines to the (upper compartment) containment spray ring headers from the RHR Heat Exchangers. These valves are in closed position during normal plant operation. The valves are exposed to containment atmosphere on the downstream side and are isolated from fluid pressure in the upstream side by the closed motor operated valves. The valves cannot be part or full stroke exercised during power operation, cold shutdown or refueling because flow through these valves would result in spraying the containment. This could cause problems with wet lagging, corrosion of components inside the containment, etc. The only practical method available to exercise these valves is by disassembly. The valves are not equipped with position indicators. The valves will be disassembled, manually full stroke exercised and visually examined on a sampling basis (one of two) per GL-89-04, Attachment 1, Item #2, once every other refueling frequency.

NOTE 6: CTS-109 and -110 (Cold Shutdown Justification): These check valves function as vacuum breakers for spray additive tank. The check valves are closed during normal plant operation to maintain the tank pressurized. The valves will be verified closed quarterly during power operation and will be verified open at cold shutdown frequency.

DONALD C. COOK NUCLEAR PLANT

VALVE TEST PROGRAM

RELIEF REQUEST NOTES

Flow Diagram No: 1-5144-28

Revision No: 3

Date: 2-5-90

NOTE 7: CTS-127E&W, CTS-131E&W, RH-141,-142 (Code Relief): These valves are to be seat leakage tested in accordance with the unique testing methods established in the FSAR because of the configuration at D.C. Cook Plant. The permissible seat leakage values of these valves are listed in Attachment "A".

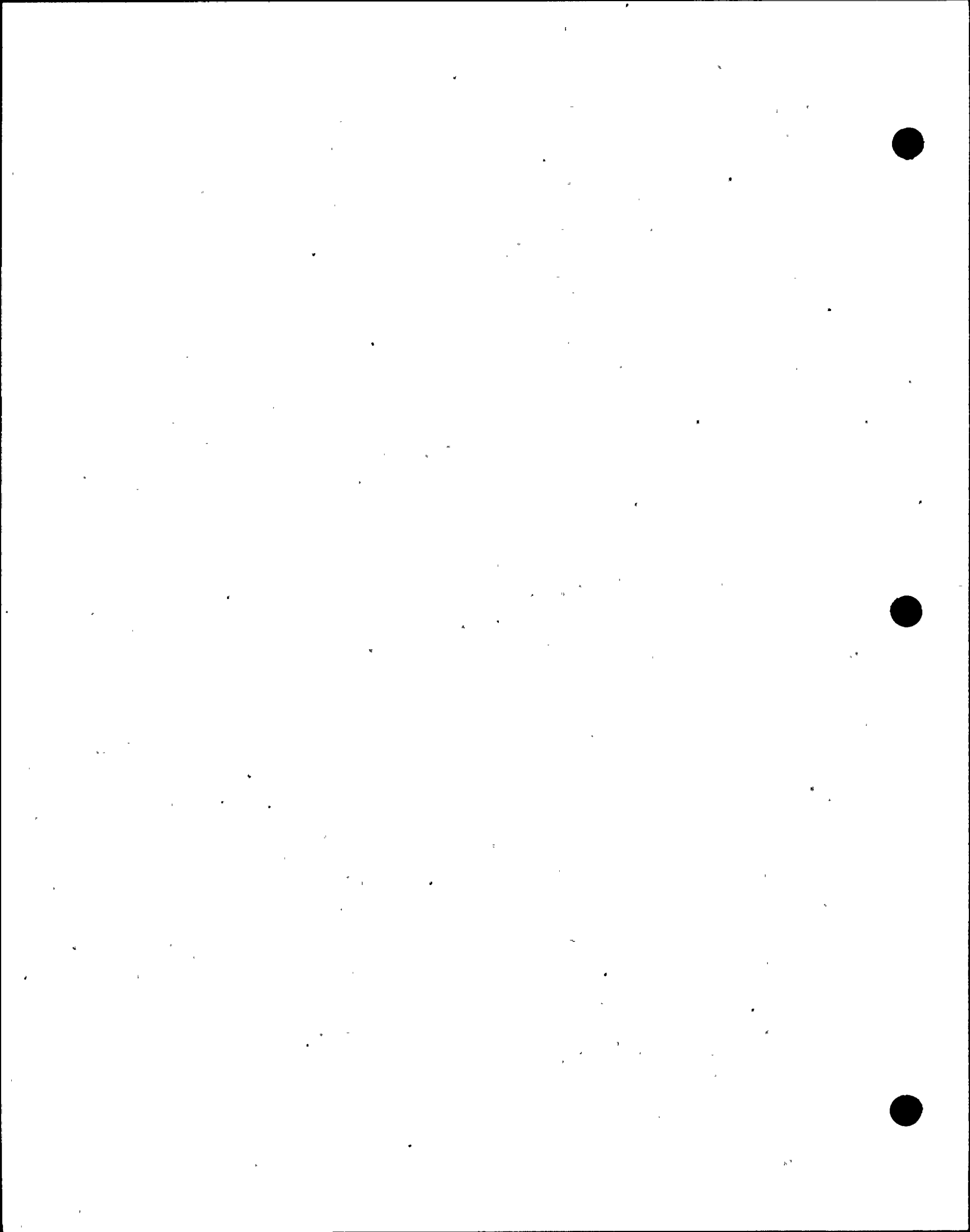

DONALD C. COOK NUCLEAR PLANT

VALVE TEST PROGRAM

RELIEF REQUEST NOTES

Flow Diagram No: 1-5145-17

Revision No: 3

Date: 2-5-90

NOTE 1: CA-181-N&S (Code Relief): See "Attachment-A" for permissible seat leakage values.

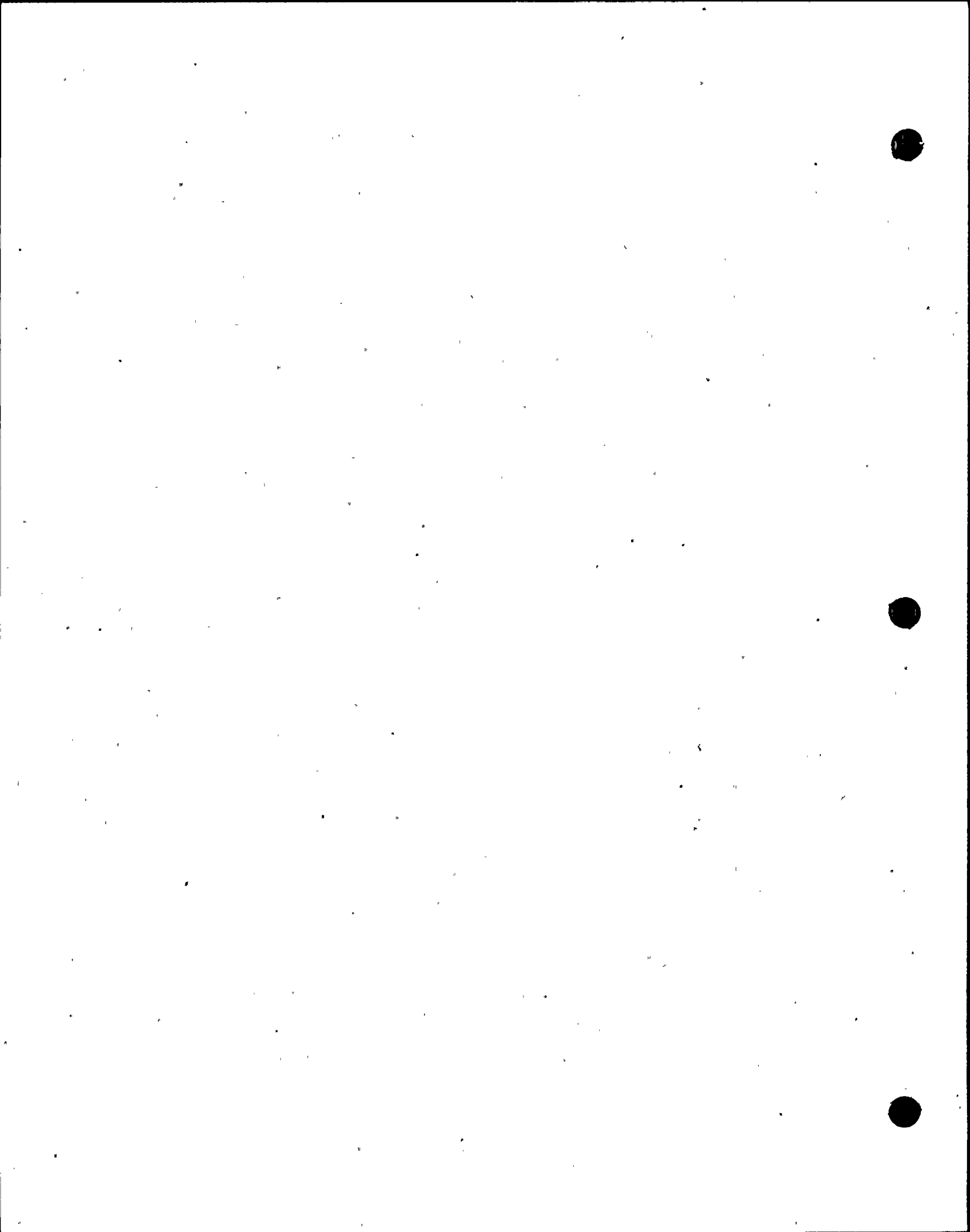

DONALD C. COOK NUCLEAR PLANT

VALVE TEST PROGRAM

RELIEF REQUEST NOTES

Flow Diagram No: 1-5146B-24

Revision No: 3

Date: 2-5-90

NOTE 1: R-156 and R-157 (Code Relief): These check valves are installed in parallel lines to the glycol main supply and return lines to relieve glycol thermal expansion. These valves and necessary test connections are located inside the containment. Due to the plant design, the only method available to verify valve closure is leak testing. The valves are not equipped with position indicators. The valves will be full stroke exercised in the open direction quarterly and verified closed in conjunction with Appendix J seat leakage testing at refueling frequency.

NOTE 2: R-156 and -157, VCR-10, -11, -20 and -21 (Code Relief):
See "Attachment-A" for permissible seat leakage values.

DONALD C. COOK NUCLEAR PLANT

VALVE TEST PROGRAM

RELIEF REQUEST NOTES

Flow Diagram No: 1-5147A-34

Revision No: 3

Date: 2-5-90

NOTE 1: SM-4, -6, -8 and -10, VCR-101 through -107 and VCR-201 through -207
(Code Relief): See "Attachment-A" for permissible leakage values.

DONALD C. COOK NUCLEAR PLANT

VALVE TEST PROGRAM

RELIEF REQUEST NOTES

Flow Diagram No: 1-5149-20

Revision No: 3

Date: 2-5-90

NOTE 1: VRV-325, -315 (Code Relief): These thermostatically controlled valves are located at the outlet of the control room air conditioner water pump. These three-way valves function to modulate water flow through the air handler package based on cooling requirements. These valves are normally in an intermediate position based on control room cooling load. These valves can not be full stroke exercised because there is no provision to fully close the valves. The valves will be part stroke exercised from an intermediate position in conjunction with fail safe testing on quarterly basis. These valves are demonstrated operable during normal control room air conditioning operation. The valves cannot be stroked timed because they are not equipped with position indicator and stroke times are not repeatable.

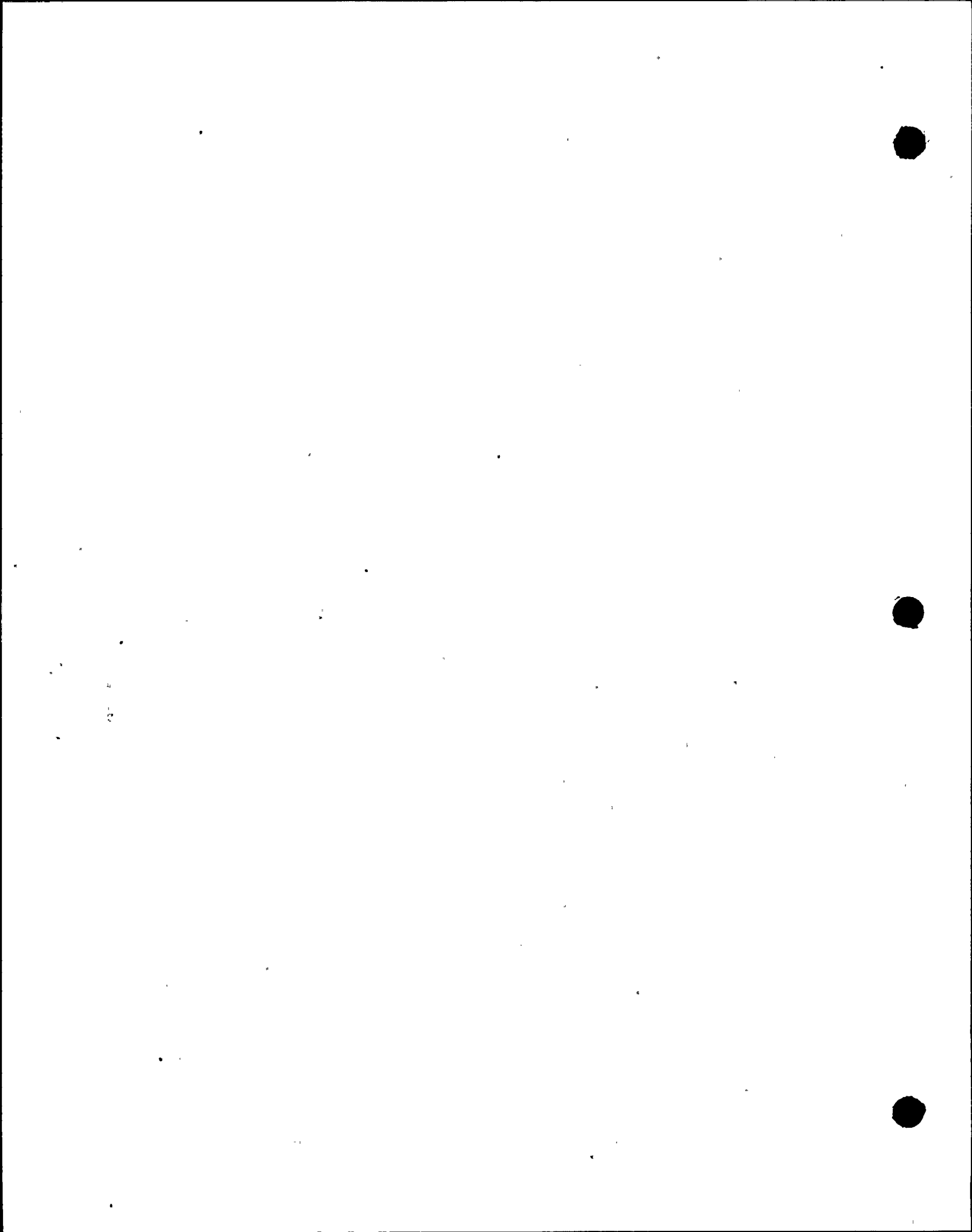

DONALD C. COOK NUCLEAR PLANT

VALVE TEST PROGRAM

RELIEF REQUEST NOTES

Flow Diagram No: 1-5151A-25

Revision No: 3

Date: 2-5-90

NOTE 1: DL-113A, -115A, -125A, -131A and -157A (Comment): The required full stroking of the check valves is satisfied when the diesel generator successfully completes its required testing per Technical Specification 4.8.1.1.2.

NOTE 2: QT-114-1AB (Code Relief): This valve is located at the discharge of the engine driven lube oil pump (diesel-generator). This three-way thermostatic valve functions to maintain the correct lube oil temperature by maintaining the correct proportion of oil flowing through the lube oil cooler and bypassing the lube oil cooler to maintain a preset lube oil temperature. We are requesting exemption from testing requirements since (1) this valve functions only as a regulating valve and not opened/closed; (2) this valve is demonstrated operable during diesel generator testing. Diesel generators are tested basis per Technical Specification 4.8.1.1.2. The valves will be verified operable by observing proper temperatures during diesel testing.

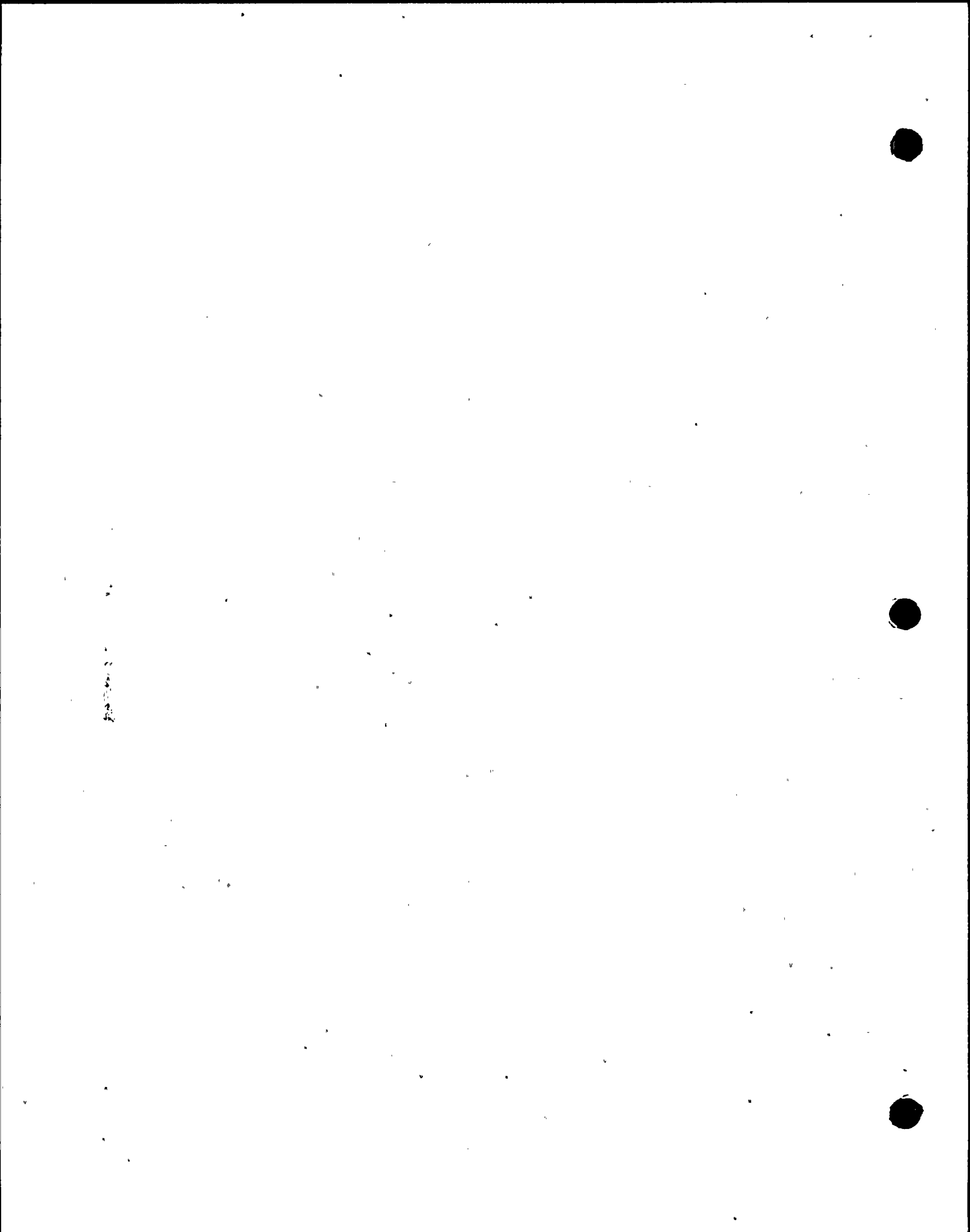

DONALD C. COOK NUCLEAR PLANT

VALVE TEST PROGRAM

RELIEF REQUEST NOTES

Flow Diagram No: 1-5151B-28

Revision No: 3

Date: 2-5-90

- NOTE 1: DG-101A, -103A, -127A, 129A, -145A, -151A and -153A (Comment): The required full stroking of the check valves is satisfied when the diesel generator successfully completes its required testing per Technical Specification 4.8.1.1.2.
- NOTE 2: QT-132-1AB (Code Relief): This valve is located at the discharge of the emergency diesel engine jacket water pump. This three-way thermostatic valve functions to maintain the correct proportion of water flowing through the diesel engine water cooler and bypassing the diesel engine jacket water cooler to maintain a preset jacket water temperature. We are requesting exemption from the testing requirements since (1) this valve functions only as a regulating valve and not open/closed valve; (2) this valve is demonstrated operable during diesel generator testing. Diesel generators are tested per Technical Specification 4.8.1.1.2. The valve will be verified operable by observing proper temperatures during diesel testing.
- NOTE 3: XRV-221 and 222 -Starting Air (Code Relief): The starting air valves are installed on parallel air supply lines to the emergency diesel generator (EDG). The valves are not equipped with position indication devices to directly measure valve stroke times. The valves function to provide starting air which rolls the EDG. The valves are functionally redundant to each other. These valves fail "as is," and, therefore, they have no fail safe position. Successful starting of the EDG in accordance with Technical Specification 4.8.1.1.2 (i.e., slow start at least quarterly and fast start once every 184 days within 10 seconds) will verify the valve performance. The valve stroke timing will be verified by

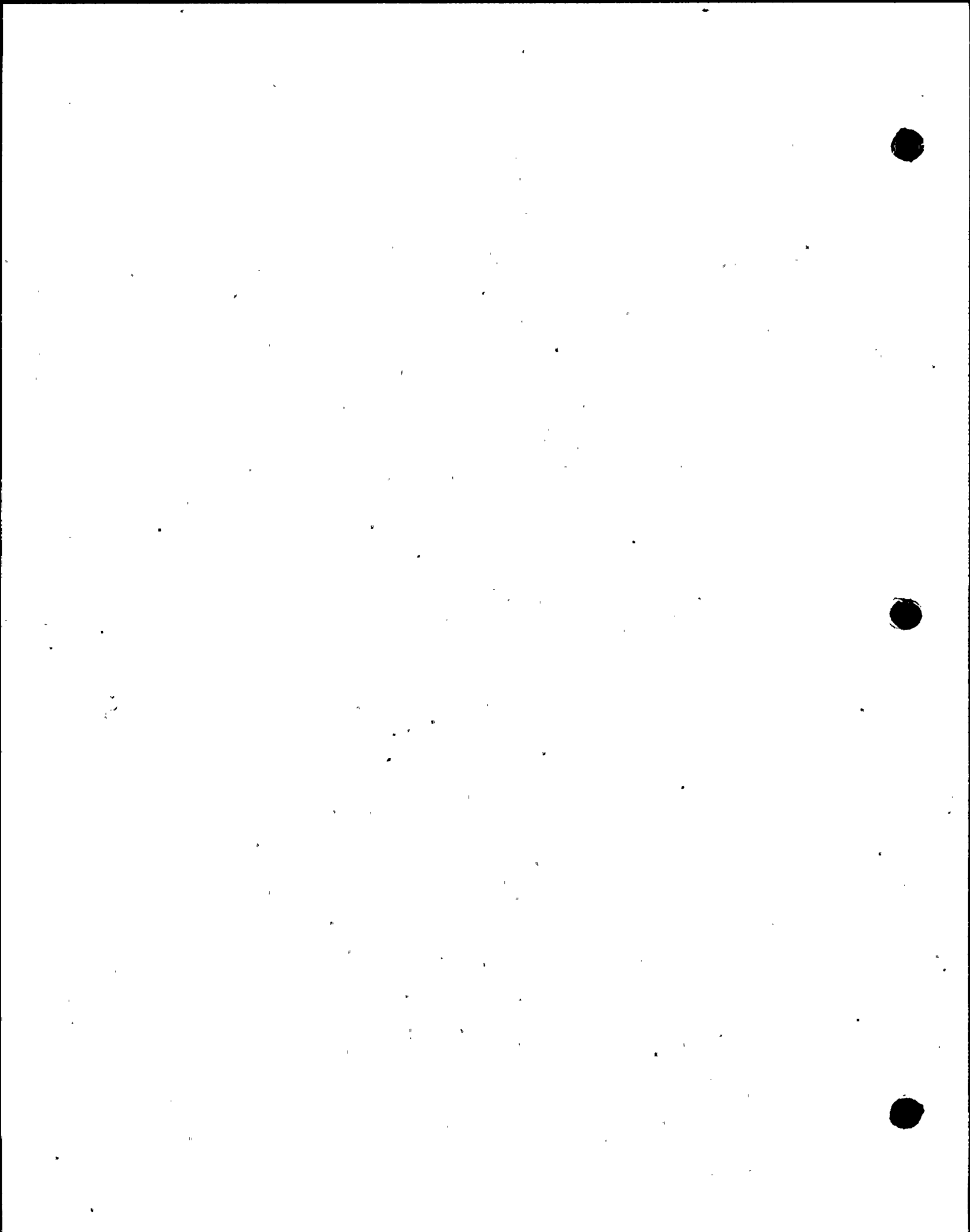

DONALD C. COOK NUCLEAR PLANT

VALVE TEST PROGRAM

RELIEF REQUEST NOTES

Flow Diagram No: 1-5151B-28

Revision No: 3

Date: 2-5-90

Note 3 (continued)

measuring diesel starting times during fast start testing of EDG. The valves on a staggered basis will be valved out one at a time to verify the operability of the opposite valve during slow start of EDG at least quarterly. Position indication will be confirmed during the above testing when only one starting air train is used to start the diesel generators.

NOTE 4: XRV-220-Jet Assist (Code Relief): This valve's function is to facilitate the EDG fast start by providing an air boost to the turbo charger to assist in starting the EDG in its Technical Specification 4.8.1.1.2 time limitation of 10 seconds. The valve is not equipped with position indication devices; therefore, meaningful stroke times are not achievable. The valves will be full stroke and fail safe tested by verifying EDG starting time once per 184 days in accordance with Technical Specification 4.8.1.1.2.

DONALD C. COOK NUCLEAR PLANT

VALVE TEST PROGRAM

RELIEF REQUEST NOTES

Flow Diagram No: 1-5151C-26

Revision No: 3

Date: 2-5-90

NOTE 1: DF-108C, -109C, -114C, -115C, DL-113C, -115C, -125C, -131C and -157C (Comment): The required full stroking of the check valves is satisfied when the diesel generator successfully completes its required testing per Technical Specification 4.8.1.1.2.

NOTE 2: QT-114-1CD (Code Relief): This valve is located at the discharge of the engine driven lube oil pump (diesel-generator). This three-way thermostatic valve functions to maintain the correct lube oil temperature by maintaining the correct proportion of oil flowing through the lube oil cooler and bypassing the lube oil cooler to maintain a preset lube oil temperature. We are requesting exemption from testing requirements since (1) this valve functions only as a regulating valve and not opened/closed valve; (2) this valve is demonstrated operable during diesel generator testing. Diesel generators are tested per Technical Specification 4.8.1.1.2. The valves will be verified operable by observing proper temperatures during diesel testing.

DONALD C. COOK NUCLEAR PLANT

VALVE TEST PROGRAM

RELIEF REQUEST NOTES

Flow Diagram No: 1-5151D-28

Revision No: 3

Date: 2-5-90

- NOTE 1: DG-101C, -103, -127C, -129C, -145C, -151C and -153C (Comment):
The required full stroking of the check valves is satisfied when the diesel generator successfully completes its required testing per Technical Specification 4.8.1.1.2.
- NOTE 2: QT-132-1CD (Code Relief): This valve is located at the discharge of the emergency diesel engine jacket water pump. This three-way thermostatic valve functions to maintain the correct proportion of water flowing through the diesel engine water cooler and bypassing the diesel engine jacket water cooler to maintain a preset jacket water temperature. We are requesting exemption from the testing requirements since (1) this valve functions only as a regulating valve and not open/closed valve; (2) this valve is demonstrated operable during diesel generator testing. Diesel generators are tested on a staggered basis, every 31 days per Technical Specification 4.8.1.1.2. The valve will be verified operable by observing proper temperatures during diesel testing.
- NOTE 3: XRV-226 and -227 -Starting Air (Code Relief): The starting air valves are installed on parallel air supply lines to the emergency diesel generator (EDG). The valves are not equipped with position indication devices to directly measure valve stroke times. The valves function to provide starting air which rolls the EDG. The valves are functionally redundant to each other. These valves fail "as is," and, therefore, they have no fail safe position. Successful starting of the EDG in accordance with Technical Specification 4.8.1.1.2 (i.e., slow start at least quarterly and fast start once every 184 days within 10 seconds) will verify the valve performance. The valve stroke timing will be verified by

DONALD C. COOK NUCLEAR PLANT

VALVE TEST PROGRAM

RELIEF REQUEST NOTES

Flow Diagram No: 1-5151D-28

Revision No: 3

Date: 2-5-90

Note 3 (continued)

measuring diesel starting times during fast start testing of EDG. The valves on a staggered basis will be valved out one at a time to verify the operability of the opposite valve during slow start of EDG at least quarterly. Position indication will be confirmed during the above testing when only one starting air train is used to start the diesel generators.

NOTE 4: XRV-225 -Jet Assist (Code Relief): This valve's function is to facilitate the EDG fast start by providing an air boost to the turbo charger to assist in starting the EDG in its Technical Specification 4.8.1.1.2 time limitation of 10 seconds. The valve is not equipped with position indication devices; therefore, meaningful stroke times are not achievable. The valves will be full stroke and fail safe tested by verifying EDG starting time once per 184 days in accordance with Technical Specification 4.8.1.1.2.

DONALD C. COOK NUCLEAR PLANT

VALVE TEST PROGRAM

RELIEF REQUEST NOTES

Flow Diagram No: 12-5115A-41 - Unit-1

Revision No: 3

Date: 2-5-90

NOTE 1: QCR-919 and -920 (Code Relief): See "Attachment-A" for permissible seat leakage values.

DONALD C. COOK NUCLEAR PLANT

VALVE TEST PROGRAM

RELIEF REQUEST NOTES

Flow Diagram No: 12-5120B-22 - Unit-1

Revision No: 3

Date: 2-5-90

NOTE 1: PA-343 (Code Relief): This check valve is located in the maintenance air supply line into the containment. The valve cannot be tested during power operation and cold shutdown because: 1) this line is generally isolated by removing a spool piece and inserting a blind flange, and 2) the valve and test connections are located inside the containment. The valve is not equipped with position indicator. Due to the plant design, the only method available to verify the valve closure is leak testing. The valve will be verified closed in conjunction with Appendix J seat leakage testing at refueling frequency.

NOTE 2: PA-343, PCR-40, XCR-100 through -103 (Code Relief):
See "Attachment-A" for permissible seat leakage values.

NOTE 3: XCR-100, -101, -102, -103 (Cold Shutdown Justification): These air operated containment isolation valves located in the control air supply lines to the containment. These valves cannot be full stroke tested during power operation without causing a loss of containment control air. Testing of these valves can potentially cause: 1) disruption of air flow to air operated valves in the containment; as a result, they would go to their fail safe position, e.g., close position for containment isolation valves, 2) systems from performing their design function, i.e, termination of system flow and change in RCS pressure and temperature, and 3) challenge to system safeguard protection which may result in a unit trip. The valves will be full stroke exercised and timed at cold shutdown frequency.

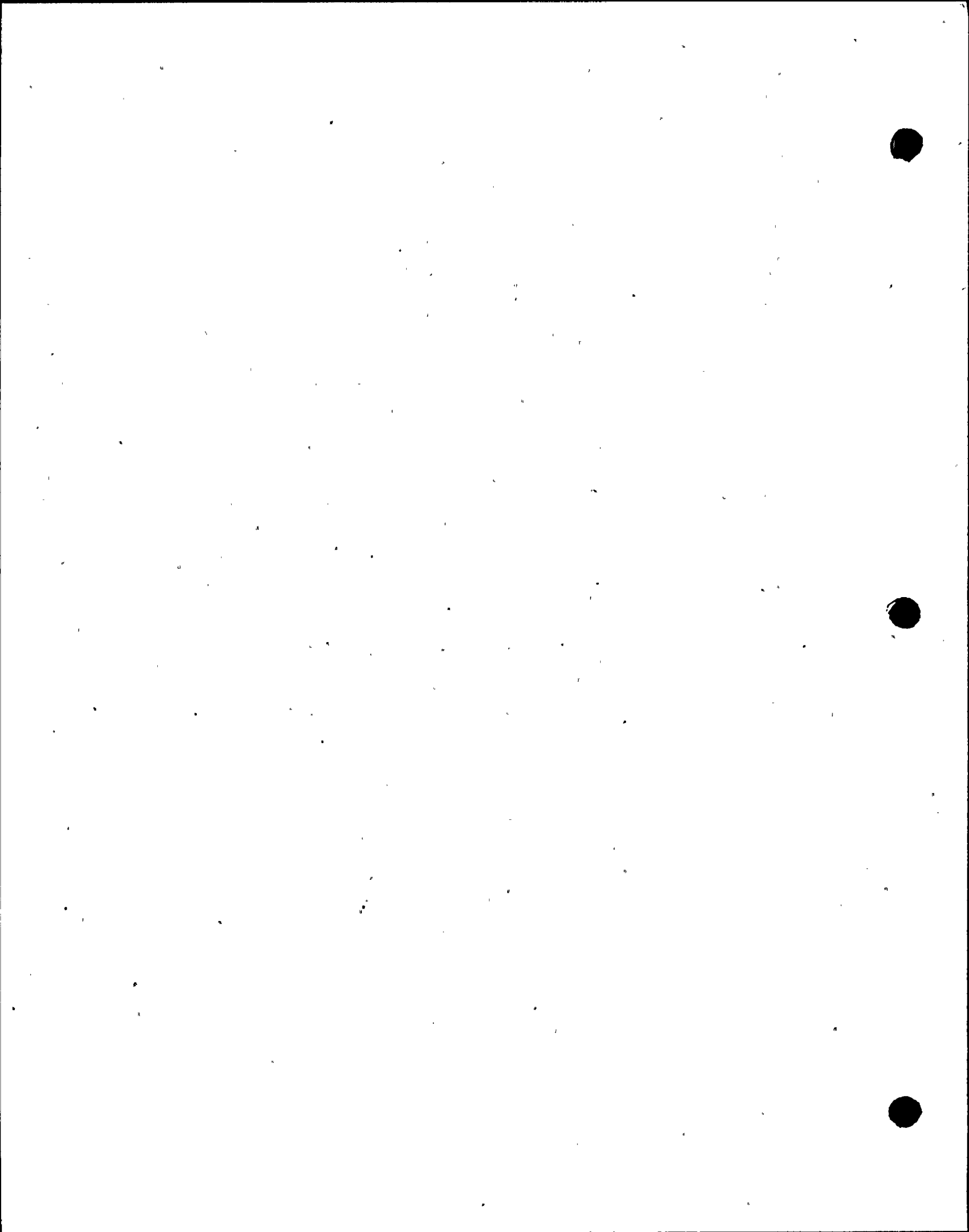

DONALD C. COOK NUCLEAR PLANT

VALVE TEST PROGRAM

RELIEF REQUEST NOTES

Flow Diagram No: 12-5131-19 -- Unit-1

Revision No: 3

Date: 2-5-90

NOTE 1: CS-427N (Cold Shutdown Justification): This valve is located in the emergency boration path. This valve cannot be tested during power operation without inserting large negative reactivity which would result in unit shutdown. The valve will be full stroke exercised at cold shutdown frequency.

DONALD C. COOK NUCLEAR PLANT

VALVE TEST PROGRAM

RELIEF REQUEST NOTES

Flow Diagram No: 12-5136-25 - Unit-1

Revision No: 3

Date: 2-5-90

NOTE 1: SF-151 and -153 (Code Relief): See "Attachment-A" for permissible seat leakage values.



DONALD C. COOK NUCLEAR PLANT

VALVE TEST PROGRAM

RELIEF REQUEST NOTES

Flow Diagram No: 12-5137A-21 - Unit-1

Revision No: 3

Date: 2-5-90

NOTE 1: DCR-201 through -207, -610, -611, -620 and -621, N-160, SF-159 and -160 (Code Relief): See "Attachment-A" for permissible seat leakage values.

NOTE 2: N-160 (Code Relief): This containment isolation check valve is located in the Nitrogen Supply line to Reactor Coolant Drain Tank. This valve cannot be part or full stroke exercised due to lack of sufficient differential pressure to back seat the valve during power operation or cold shutdown. Due to the plant design, the only method available to verify the valve closure is leak testing. The valve is not equipped with position indicator. This valve will be verified closed in conjunction with Appendix J seat leakage testing at refueling frequency.

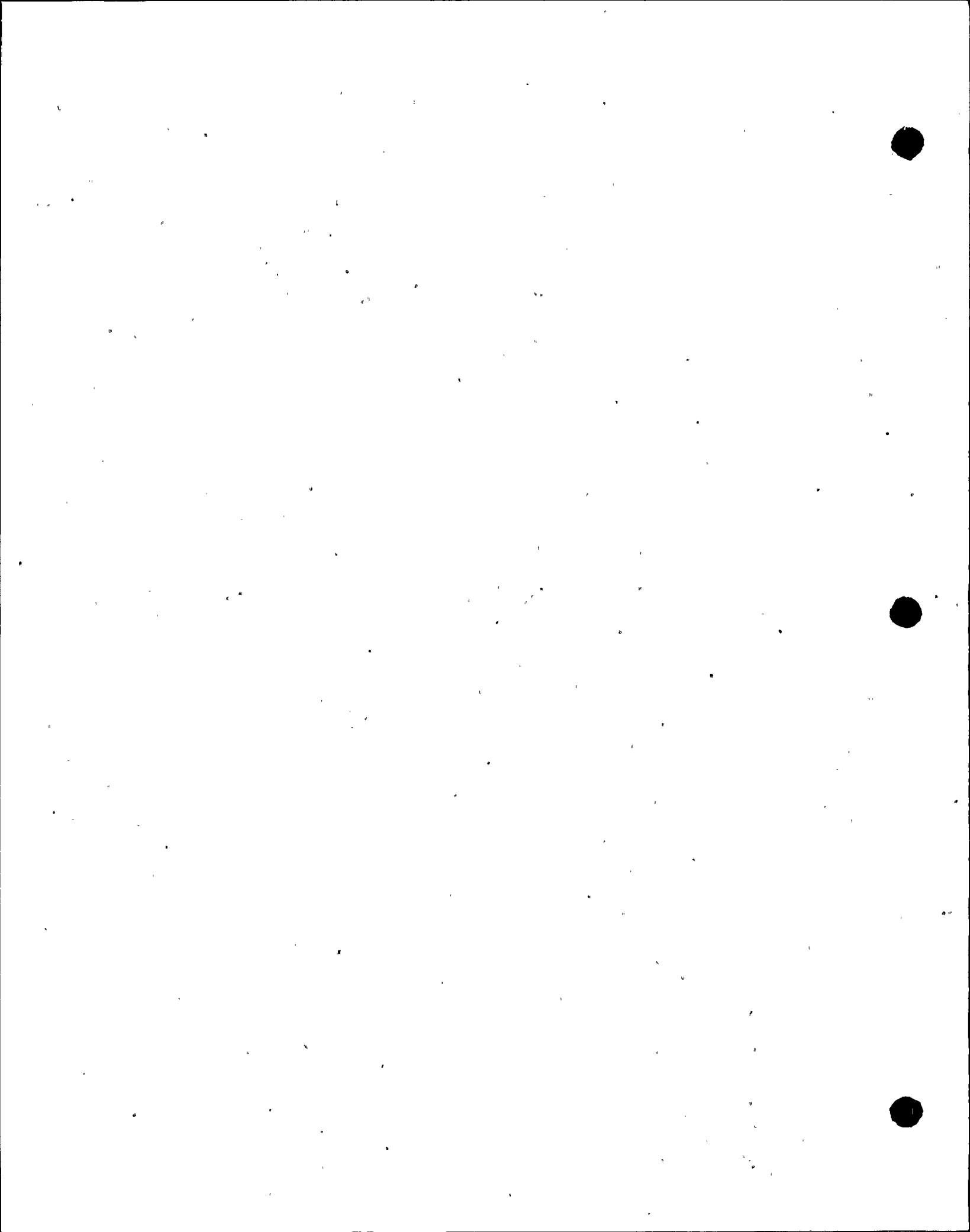

DONALD C. COOK NUCLEAR PLANT

VALVE TEST PROGRAM

RELIEF REQUEST NOTES

Flow Diagram No: 12-5141C-8 - Unit-1

Revision No: 3

Date: 2-5-90

NOTE 1: ECR-416, -417, -496, -497, -535 and -536 (Code Relief):
See "Attachment-A" for permissible seat leakage values.

DONALD C. COOK NUCLEAR PLANT

VALVE TEST PROGRAM

RELIEF REQUEST NOTES

Flow Diagram No: 12-5141F-6 - Unit-1

Revision No: 3

Date: 2-5-90

NOTE 1: ECR-36 (Cold Shutdown Justification): This valve, located in the common sample return line of the lower containment radiation monitors, cannot be part or full stroke exercised during power operation or refueling because closure of the valve would isolate both radiation monitors, which are required to be operable (Technical Specification Table 3.3-6) during power operation (Mode 1 through 4) and refueling (Mode 6). The valve will be full stroke exercised at cold shutdown frequency.

NOTE 2: ECR-31, -32, -33, -35, -36 and SM-1 (Code Relief):
See "Attachment-A" for permissible leakage values.

NOTE 3: SM-1 (Code Relief): This containment isolation check valve for the containment radiation monitors' sample return cannot be full or part stroke exercised during power operation because these monitors are required to be operable in Modes 1, 2, 3, 4, and 6. The valve is not equipped with position indication. The valve is located in the open ended return line inside the containment. The only method available to verify the valve closure is leak testing. The valve will be verified closed in conjunction with Appendix J seat leakage testing at refueling frequency.

ASME SECTION XI VALVE TEST PROGRAM FOR UNIT #1

ATTACHMENT-A

Revision No: 3

Date: 2-5-90

1. CONTAINMENT ISOLATION VALVES (Category A or AC)

Testing Method: (SLT-2) Seat leakage test the valve in accordance with 10CFR50, Appendix J, in lieu of ASME Code Section XI except for paragraphs IWV-3426 and IWV-3427, which are applicable (refer to Figure 3, Item #3).

<u>Valve No</u>	<u>Flow Diagram</u>	<u>Size</u>	<u>Type</u>	<u>Permissible Leakage Values (SCCM)</u>
WCR-920,-922	5114A	3	DA	900
WCR-921,-923	5114A	3	DA	900
WCR-932,-934	5114A	3	DA	900
WCR-933,-935	5114A	3	DA	900
WCR-941,-945	5114A	3	DA	900
WCR-944,-948	5114A	3	DA	900
WCR-951,-955	5114A	3	DA	900
WCR-954,-958	5114A	3	DA	900
WCR-924,-926	5114A	3	DA	900
WCR-925,-927	5114A	3	DA	900
WCR-928,-930	5114A	3	DA	900

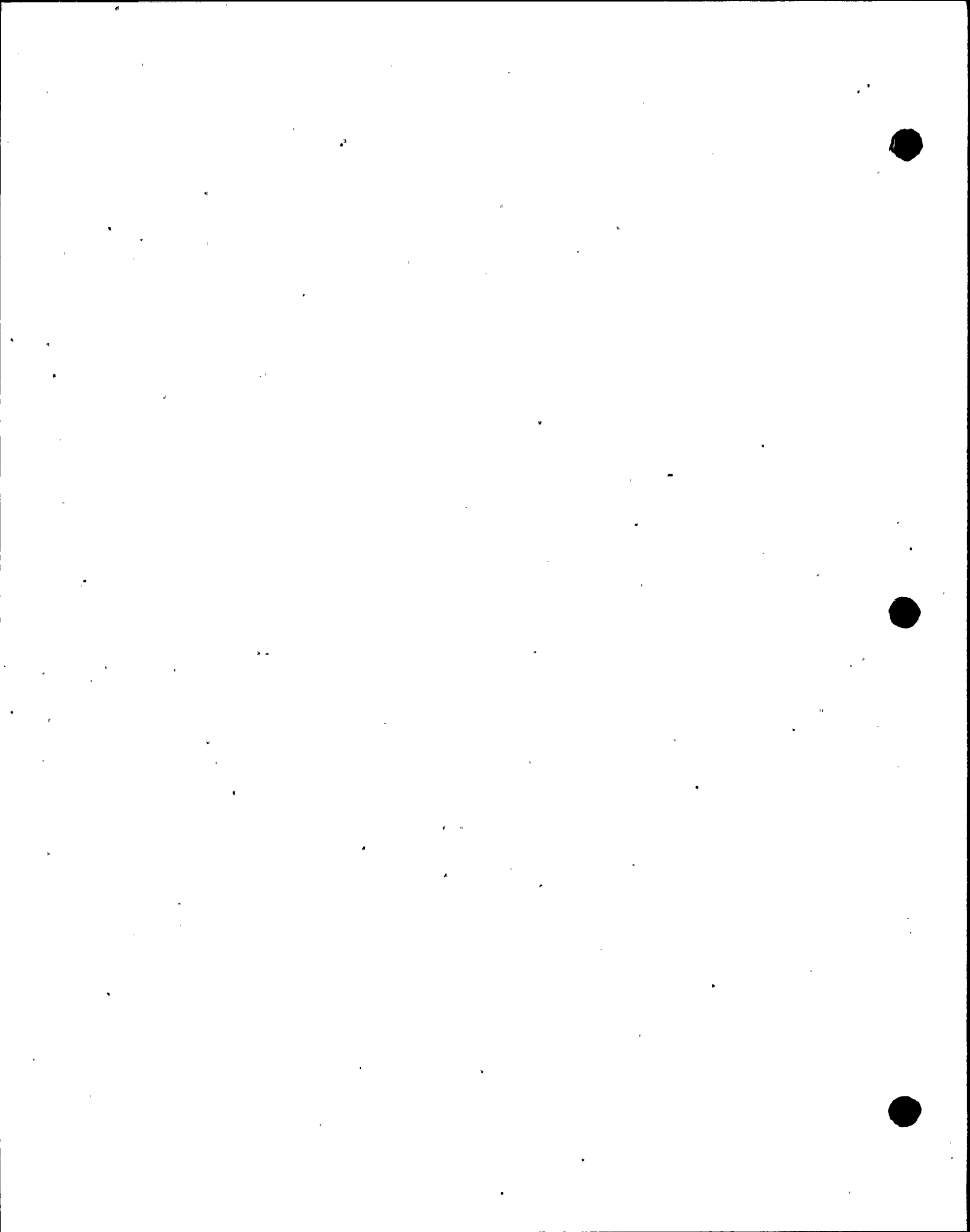

DONALD C. COOK NUCLEAR PLANT

ASME SECTION XI VALVE TEST PROGRAM FOR UNIT #1

ATTACHMENT-A

Revision No: 3

Date: 2-5-90

<u>Valve No.</u>	<u>Flow Diagram</u>	<u>Size</u>	<u>Type</u>	<u>Permissible Leakage Values (SCCM)</u>
WCR-929,-931	5114A	3	DA	900
WCR-942,-946	5114A	3	DA	900
WCR-952,-956	5114A	3	DA	900
WCR-943,-947	5114A	3	DA	900
WCR-953,-957	5114A	3	DA	900
WCR-960,-962	5114A	2	DA	750
WCR-961,-963	5114A	2	DA	750
WCR-964,-966	5114A	2	DA	750
WCR-965,-967	5114A	2	DA	750
ECR-10,-20	5141B	0.50	GL	750
ECR-11,-21	5141B	0.50	GL	750
ECR-12,-22	5141B	0.50	GL	750
ECR-13,-23	5141B	0.50	GL	750
ECR-14,-24	5141B	0.50	GL	750

DONALD C. COOK NUCLEAR PL

ASME SECTION XI VALVE TEST PROGRAM FOR UNIT #1

ATTACHMENT-A

Revision No: 3

Date: 2-5-90

<u>Valve No.</u>	<u>Flow Diagram</u>	<u>Size</u>	<u>Type</u>	<u>Permissible Leakage Values (SCCM)</u>
ECR-15,-25	5141B	0.50	GL	750
ECR-16,-26	5141B	0.50	GL	750
ECR-17,-27	5141B	0.50	GL	750
ECR-18,-28	5141B	0.50	GL	750
ECR-19,-29	5141B	0.50	GL	750
CS-442-1	5128A	2	CK	750
CS-442-2	5128A	2	CK	750
CS-442-3	5128A	2	CK	750
CS-442-4	5128A	2	CK	750
SI-189	5128A	4	CK	1200
SM-1	5141F	1	CK	750
N-102	5143	1	CK	750
N-159	5128A	0.75	CK	750
PW-275	5128A	3	CK	900

DONALD C. COOK NUCLEAR PLANT

ASME SECTION XI VALVE TEST PROGRAM FOR UNIT #1

ATTACHMENT-A

Revision No: 3

Date: 2-5-90

<u>Valve No.</u>	<u>Flow Diagram</u>	<u>Size</u>	<u>Type</u>	<u>Permissible Leakage Values (SCCM)</u>
CS-321	5129	3	CK	1800
VCR-10,-11	5146B	4	DA	1200
VCR-20,-21	5146B	4	DA	1200
DCR-203,-207	5137A	1	DA, GL	750
N-160, DCR-201	5137A	1	CK, DA	1125
DCR-610,-611	5137A	2.50	DA	750
DCR-620,-621	5137A	1	DA	750
DCR-205,-206	5137A	4	DA	1200
DCR-600,-601	5124	3	DA	900
QCR-300,-301	5129	2	GL	750
QCM-250,-350	5129A	4	GA	1200
QCR-919,-920	5115A	2	DA	750
SF-152,-154	5136	2.50	DA, GL	750
SF-159,-160	5137A	3	DA	900

DONALD C. COOK NUCLEAR PLANT

ASME SECTION XI VALVE TEST PROGRAM FOR UNIT #1

ATTACHMENT-A

Revision No: 3

Date: 2-5-90

<u>Valve No.</u>	<u>Flow Diagram</u>	<u>Size</u>	<u>Type</u>	<u>Permissible Leakage Values (SCCM)</u>
NCR-105,-106	5141	0.50	GL	750
NCR-107,-108	5141	0.50	GL	750
NCR-109,-110	5141	0.50	GL	750
RCR-100,-101	5128A	0.375	GL	750
DCR-202,-204	5137A	0.75	DA	750
ICR-5,-6	5141	0.50	GL	750
ECR-33,-35	5141F	0.75,2	GL,DA	750
ICM-260	5142	4	GA(DD)*	600
ICM-265	5142	4	GA(DD)*	600
ECR-31,-32	5141F	1	GL	750
XCR-100,-101	5120B	.1	GL	750
XCR-102,-103	5120B	1	GL	750
GCR-301	5128A	0.75	DA	375
GCR-314	5143	1	GL	375

* Double Discs

DONALD C. COOK NUCLEAR PLANT

ASME SECTION XI VALVE TEST PROGRAM FOR UNIT #1

ATTACHMENT-A

Revision No: 3

Date: 2-5-90

<u>Valve No.</u>	<u>Flow Diagram</u>	<u>Size</u>	<u>Type</u>	<u>Permissible Leakage Values (SCCM)</u>
SI-171,-172,-194	5143	0.75	GL	1125
NCR-252	5128A	3	GL	450
CCR-460,-462	5135	3	GL	900
CCR-457,CCW-135	5135	2,2.50	GL,CK	1125
CCR-455,-456	5135	2	GL	750
SM-4,-6	5147A	0.50	GL	750
ICM-251	5142	4	GA(DD)*	600
ICM-250	5142	4	GA(DD)*	600
CA-181S	5145	0.50	CK	750
CA-181N	5145	0.50	CK	750
SM-8,-10	5147A	0.50	ND	750
CCW-243-25	5135B	1	CK	750
CCW-244-25	5135B	1	CK	750

* Double Discs

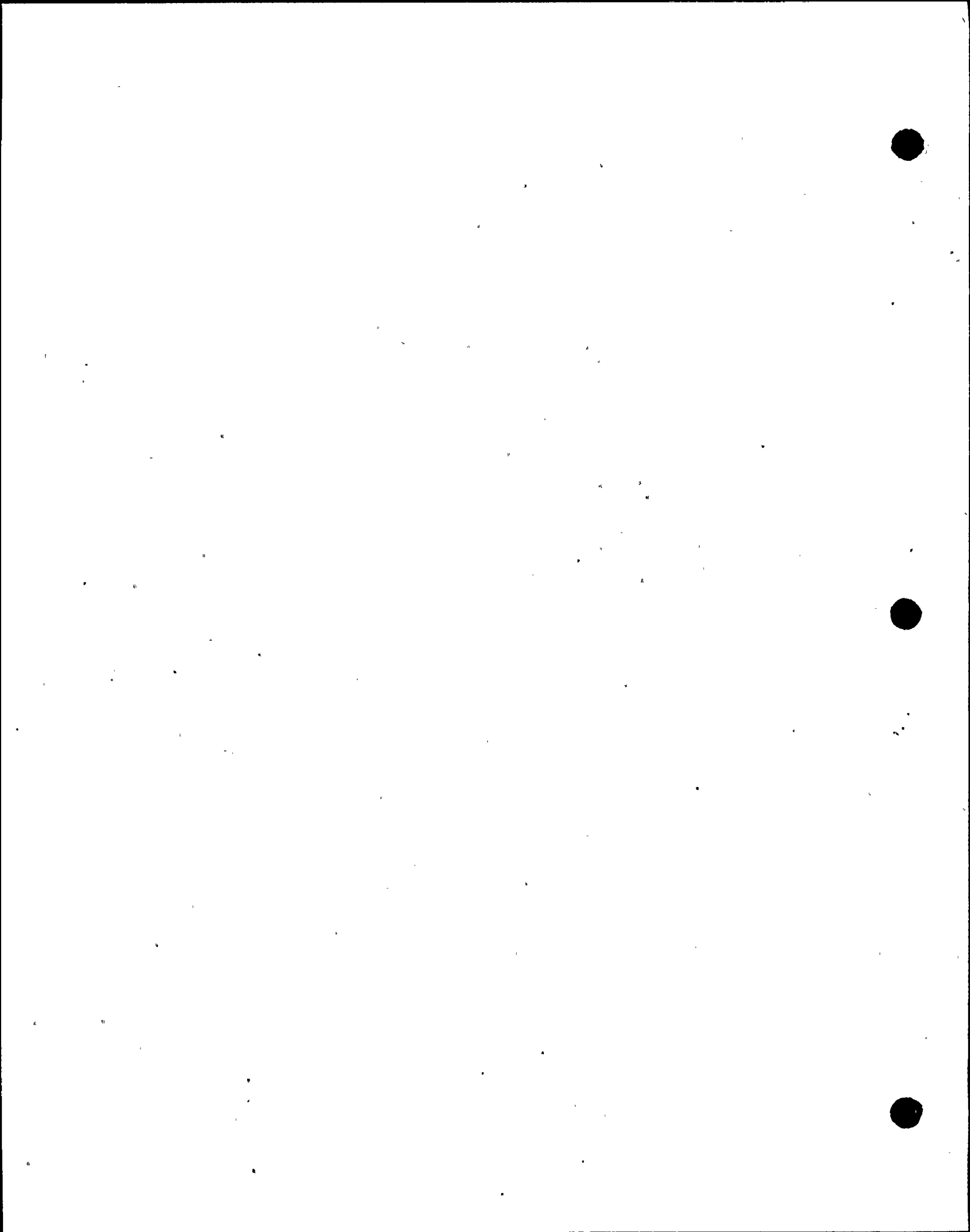

DONALD C. COOK NUCLEAR PLANT

ASME SECTION XI VALVE TEST PROGRAM FOR UNIT #1

ATTACHMENT-A

Revision No: 3

Date: 2-5-90

<u>Valve No.</u>	<u>Flow Diagram</u>	<u>Size</u>	<u>Type</u>	<u>Permissible Leakage Values (SCCM)</u>
CCW-243-72	5135B	1	CK	750
CCW-244-72	5135B	1	CK	750
CCM-430	5135B	1.50	GL	375
CCM-431	5135B	1.50	GL	375
CCR-440	513B	1.50	GL	375
CCR-441	5135B	1.50	GL	375
CCM-432	5135B	1.50	GL	375
CCM-433	5135B	1.50	GL	375
R-156	5146B	0.375	CK	750
R-157	5146B	0.375	CK	750
NS-357	5124	0.50	CK	750
ECR-496,-497	5141C	0.50	GL	750
ECR-416	5141C	0.50	GL	375
ECR-417	5141C	0.50	GL	375
ECR-535	5141C	0.50	GL	375

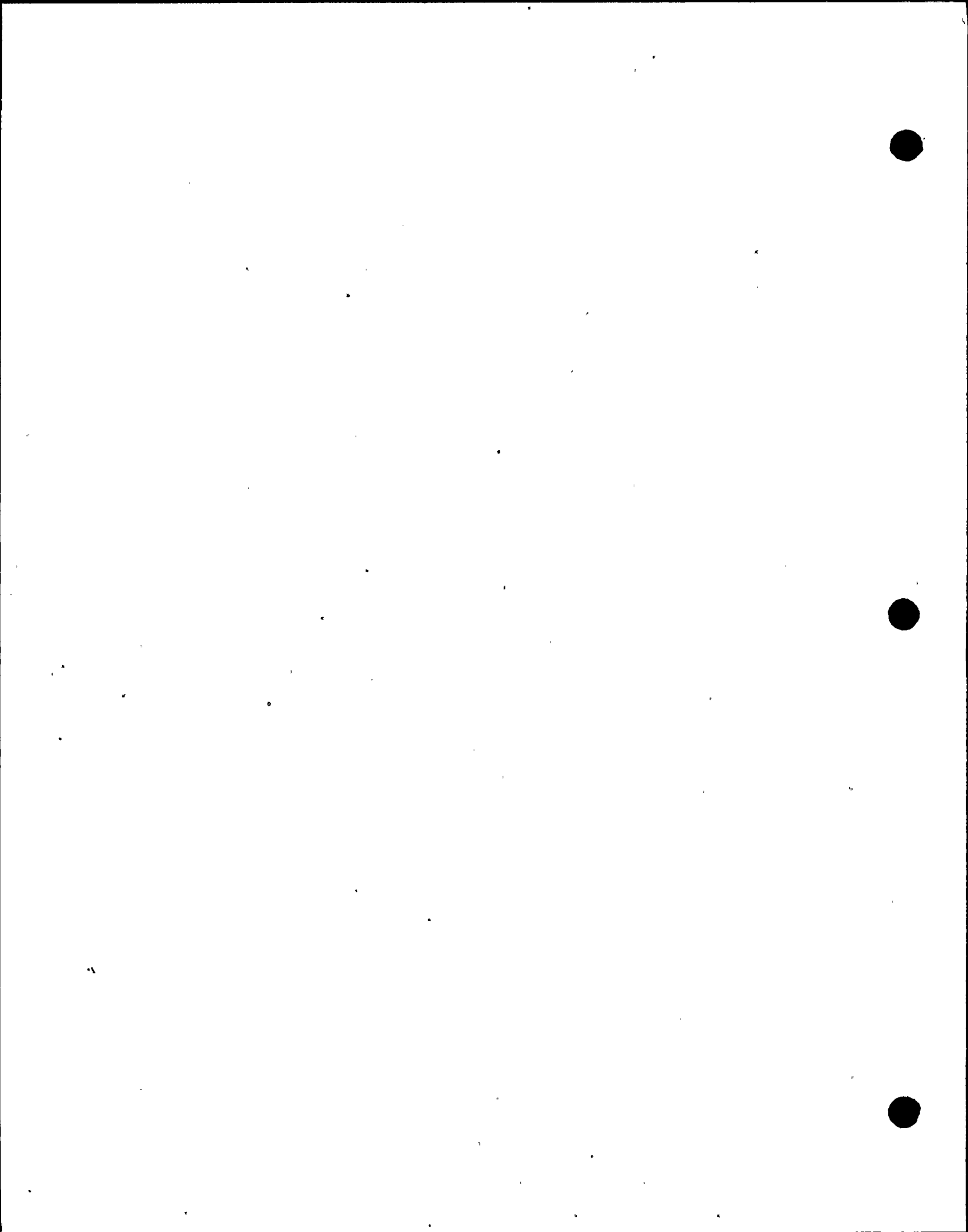

DONALD C. COOK NUCLEAR PLANT

ASME SECTION XI VALVE TEST PROGRAM FOR UNIT #1

ATTACHMENT-A

Revision No: 3

Date: 2-5-90

<u>Valve No.</u>	<u>Flow Diagram</u>	<u>Size</u>	<u>Type</u>	<u>Permissible Leakage Values (SCCM)</u>
ECR-536	5141C	0.50	GL	375
ECR-36	5141F	2	DA	375
PCR-40	5120B	2	GA	375
PA-342	5120B	2	CK	750
NS-283	5141D	0.50	CK	750
NPX-151	5128A	0.50	GL	375
WCR-900,-902	5114A	6	DA	1800
WCR-901,-903	5114A	6	DA	1800
WCR-912,-914	5114A	6	DA	1800
WCR-913,-915	5114A	6	DA	1800
WCR-904,-906	5114A	6	DA	1800
WCR-905,-907	5114A	6	DA	1800
WCR-908,-910	5114A	6	DA	1800
WCR-909,-911	5114A	6	DA	1800
VCR-101,-201	5147A	14	BF	4200

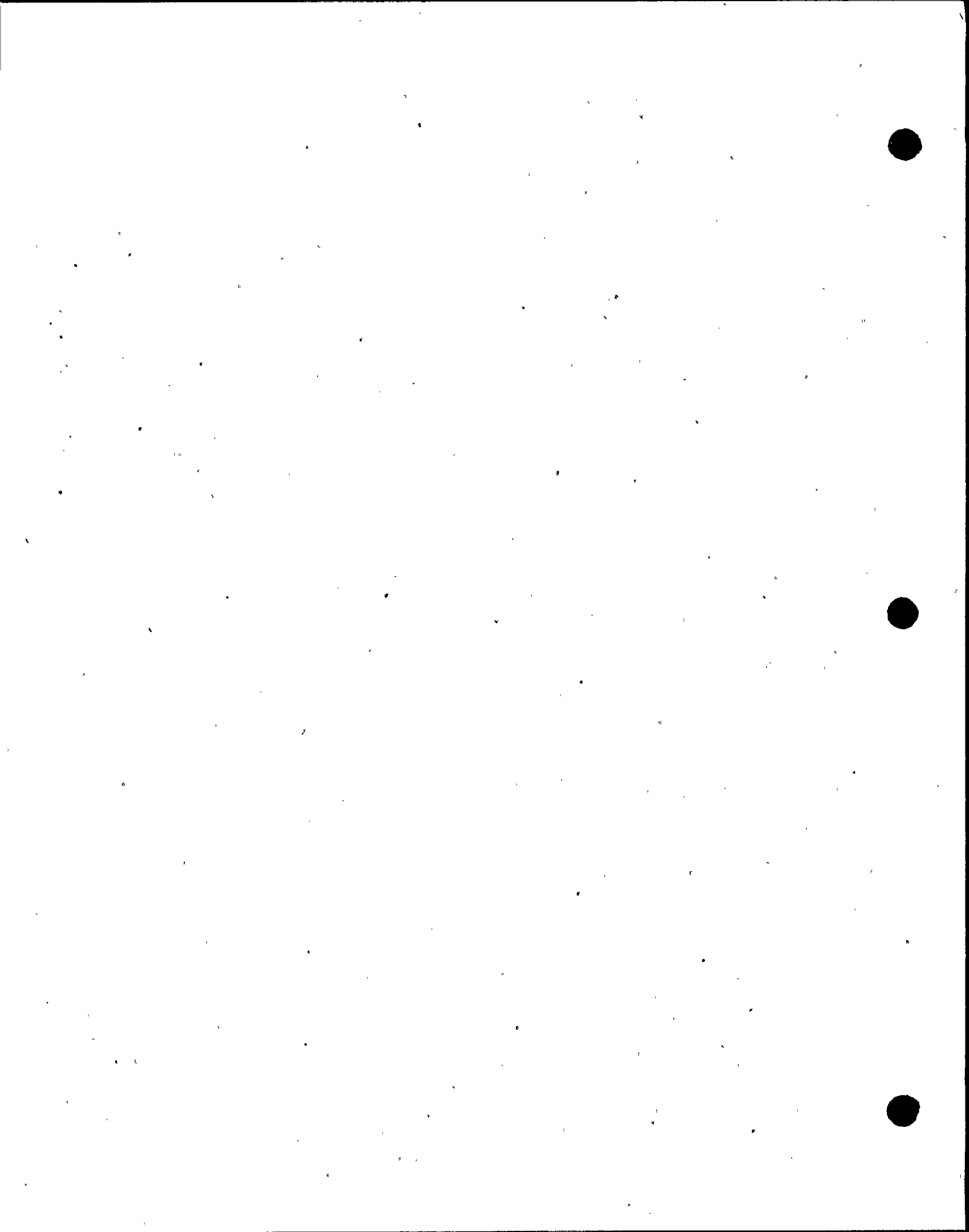

DONALD C. COOK NUCLEAR PLANT

ASME SECTION XI VALVE TEST PROGRAM FOR UNIT #1

ATTACHMENT-A

Revision No: 3

Date: 2-5-90

<u>Valve No.</u>	<u>Flow Diagram</u>	<u>Size</u>	<u>Type</u>	<u>Permissible Leakage Values (SCCM)</u>
VCR-102,-202	5147A	14	BF	4200
VCR-103,-203	5147A	24	BF	7200
VCR-104,-204	5147A	30	BF	9000
VCR-105,-205	5147A	30	BF	9000
VCR-106,-206	5147A	24	BF	7200
VCR-107,-207	5147A	14	BF	4200
ICM-305	5143	18	GA(DD)*	2700
ICM-306	5143	18	GA(DD)*	2700
CCM-452,-454,-458	5135	8,4,8	BF,GL,BF	3000
CCM-451,-453,-459	5135	8,4,8	BF,GL,BF	3000

* Double Discs

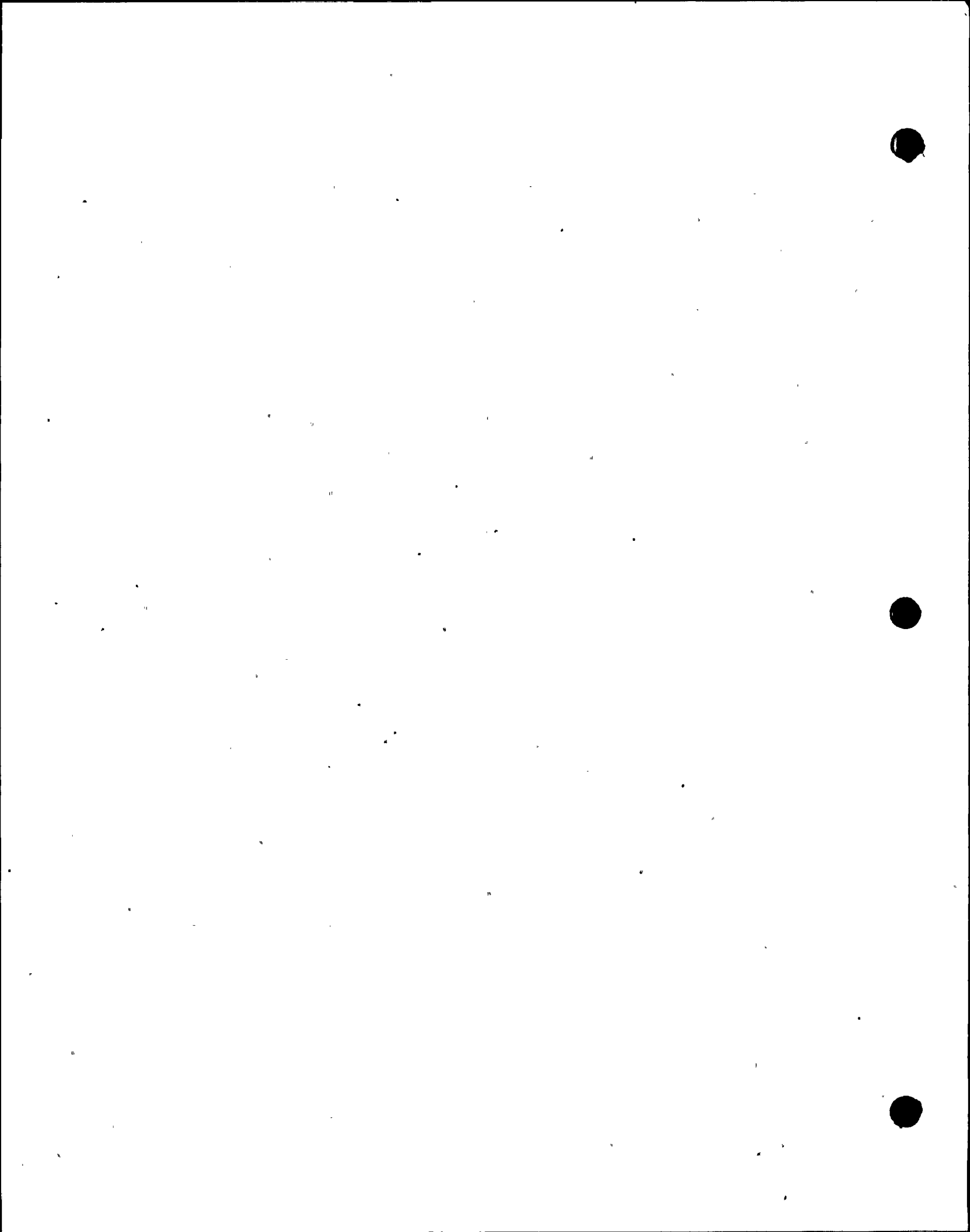

DONALD C. COOK NUCLEAR PLANT

ASME SECTION XI VALVE TEST PROGRAM FOR UNIT #1

ATTACHMENT-A

Revision No: 3

Date: 2-5-90

2. CONTAINMENT SPRAY VALVES (Category A or AC)

Testing Method: As described in "SLT-2A," Figure 3, Item #3.

<u>Valve No.</u>	<u>Flow Diagram</u>	<u>Size</u>	<u>Type</u>	<u>Permissible Leakage Values (CCM)</u>
CTS-131W	5144	8	CK	35.00
CTS-131E	5144	8	CK	35.00
CTS-127W	5144	6	CK	22.55
CTS-127E	5144	6	CK	21.21
RH-141	5144	8	CK	20.70
RH-142	5144	8	CK	23.00

ASME SECTION XI VALVE TEST PROGRAM FOR UNIT #1

ATTACHMENT-A

Revision No: 3

Date: 2-5-90

3. PRESSURE ISOLATION VALVES (Category A or AC)

Testing Method: (SLT-1) Seat leakage test the valve per ASME Code Section XI (refer to Figure 3, Item #3).

<u>Valve No.</u>	<u>Flow Diagram</u>	<u>Size</u>	<u>Type</u>	<u>Permissible Leakage Values (GPM)</u>
CS-299E	5129	4	CK	2.0
CS-299W	5129	4	CK	2.0
SI-152-N	5143	4	CK	5.0
SI-152-S	5143	4	CK	5.0
ICM-129	5143	14	GA(DD)*	10.0
SI-161-L1,-L4	5143	6	CK	10.0
SI-161-L2,-L3	5143	6	CK	10.0
SI-170-L1	5143	10	CK	5.0
SI-170-L2	5143	10	CK	1.0
SI-170-L3	5143	10	CK	1.0

* Double Discs

DONALD C. COOK NUCLEAR PLANT

ASME SECTION XI VALVE TEST PROGRAM FOR UNIT #1

ATTACHMENT-A

Revision No: 3

Date: 2-5-90

<u>Valve No.</u>	<u>Flow Diagram</u>	<u>Size</u>	<u>Type</u>	<u>Permissible Leakage Values (GPM)</u>
SI-170-L4	5143	10	CK	5.0
SI-158-L1,-L4	5143	6	CK	10.0
SI-158-L2,-L3	5143	6	CK	10.0
SI-151-E	5143	8	CK	5.0
SI-151-W	5143	8	CK	5.0
SI-166-L1	5143	10	CK	5.0
SI-166-L2	5143	10	CK	5.0
SI-166-L3	5143	10	CK	5.0
SI-166-L4	5143	10	CK	5.0
RH-133,-134	5143	8	CK	1.0

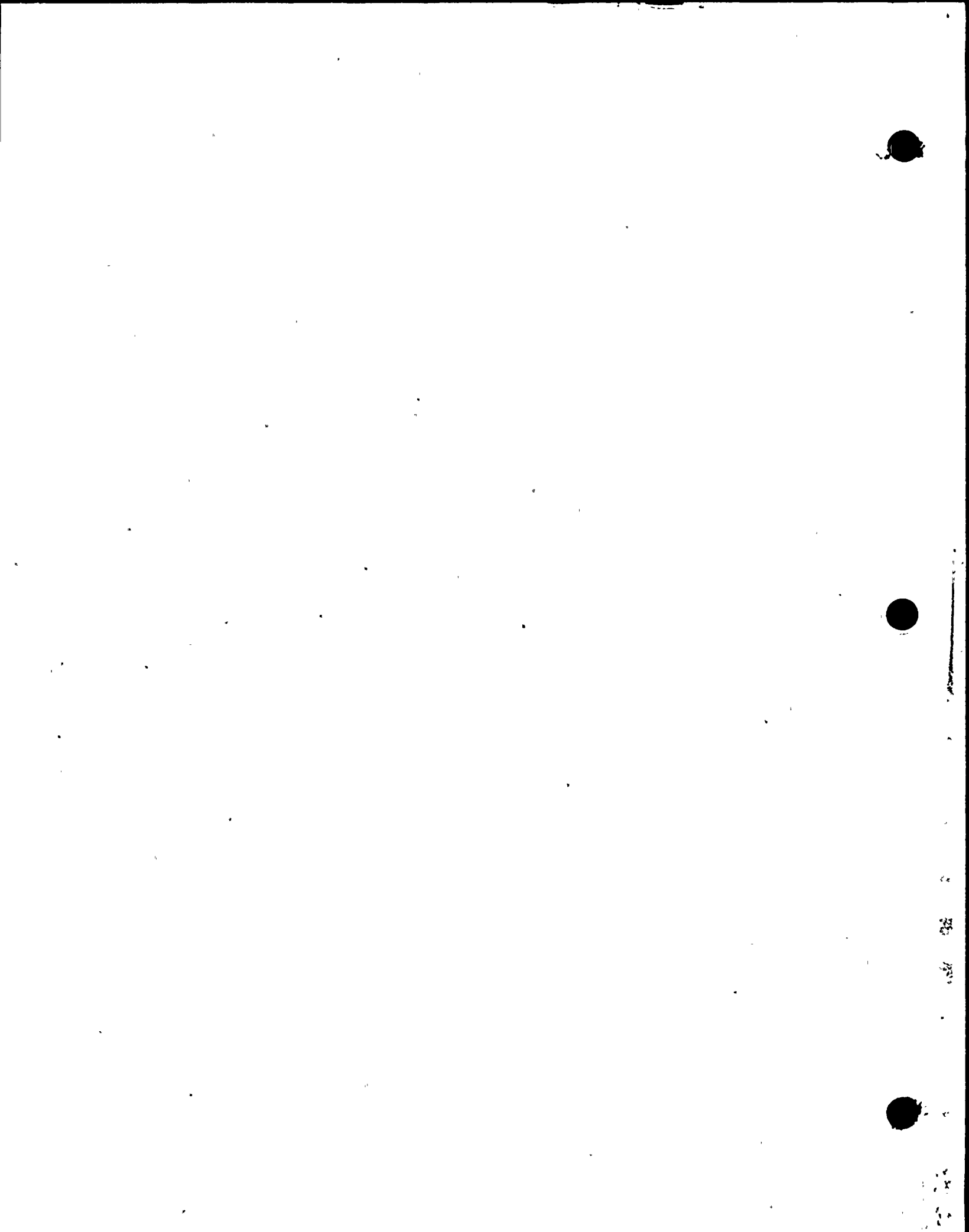

DONALD C. COOK NUCLEAR PLANT
 SECOND TEN YEAR INTERVAL
 VALVE SUMMARY SHEET - UNIT 1
 FLOW DIAGRAM: 1-5105-29

RUN DATE AND TIME: 15FEB90:16:03

SYSTEM NAME: MAIN STEAM

VALVE				VALVE POSITION				ASME SECTION XI						
NUMBER	REV	TYPE	SIZE	ACT TYPE	F.D. COORD	POWER OPER	SAFETY FUNCT	CD ICL	A/P	CAT	PRIM TEST REQUIRED	TEST PERFORMED	TEST MODE	RELIEF REQUEST(S)
1-DCR-310	3	GL	2	A	D/5	0	C	2	A	B	EF-1 EF-5 EF-7 ET-XXX	EF-1 EF-5 EF-7 ET-XXX	P - P P	NO NO NO NO
1-DCR-320	3	GL	2	A	D/5	0	C	2	A	B	EF-1 EF-5 EF-7 ET-XXX	EF-1 EF-5 EF-7 ET-XXX	P - P P	NO NO NO NO
1-DCR-330	3	GL	2	A	D/5	0	C	2	A	B	EF-1 EF-5 EF-7 ET-XXX	EF-1 EF-5 EF-7 ET-XXX	P - P P	NO NO NO NO
1-DCR-340	3	GL	2	A	D/5	0	C	2	A	B	EF-1 EF-5 EF-7 ET-XXX	EF-1 EF-5 EF-7 ET-XXX	P - P P	NO NO NO NO

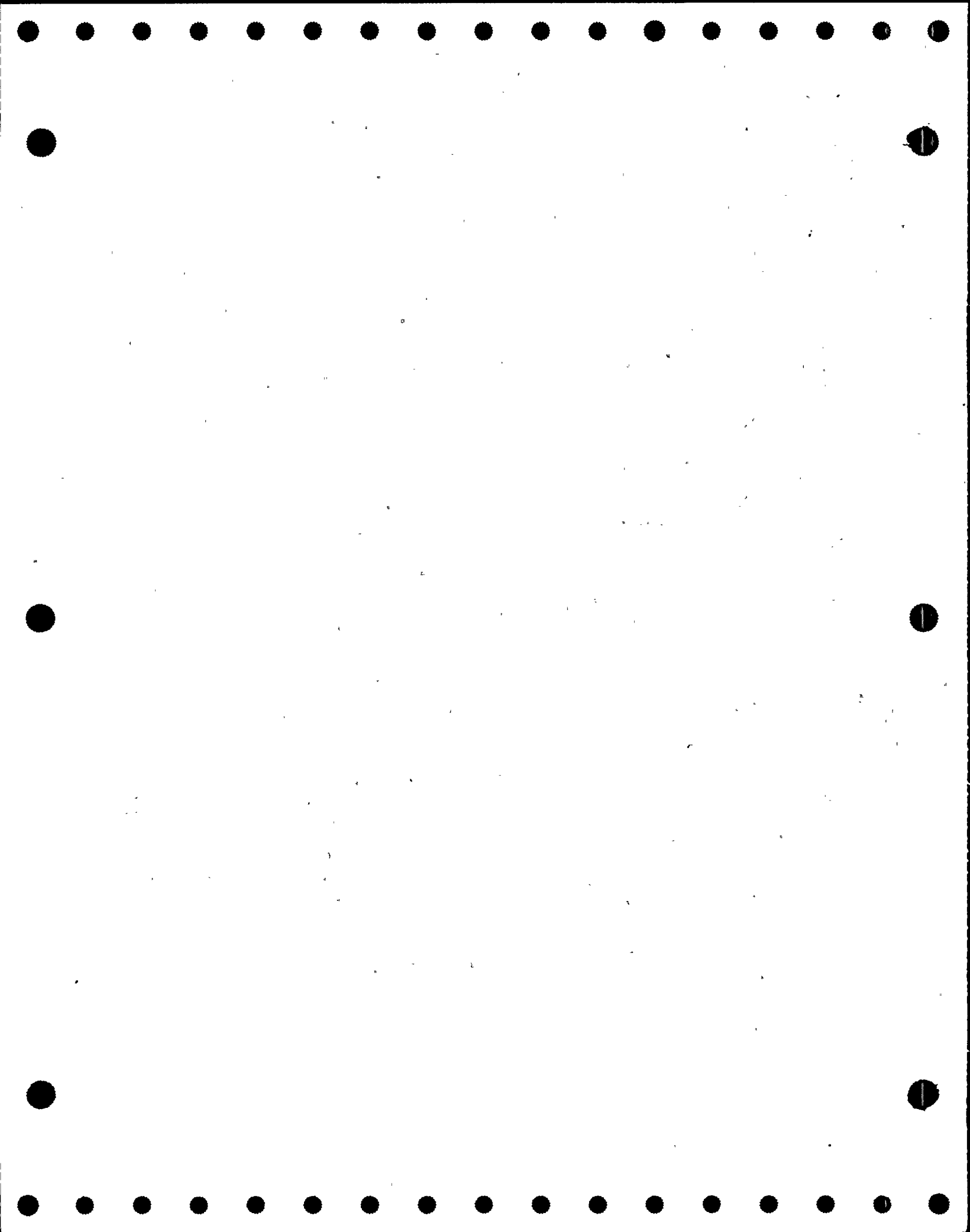

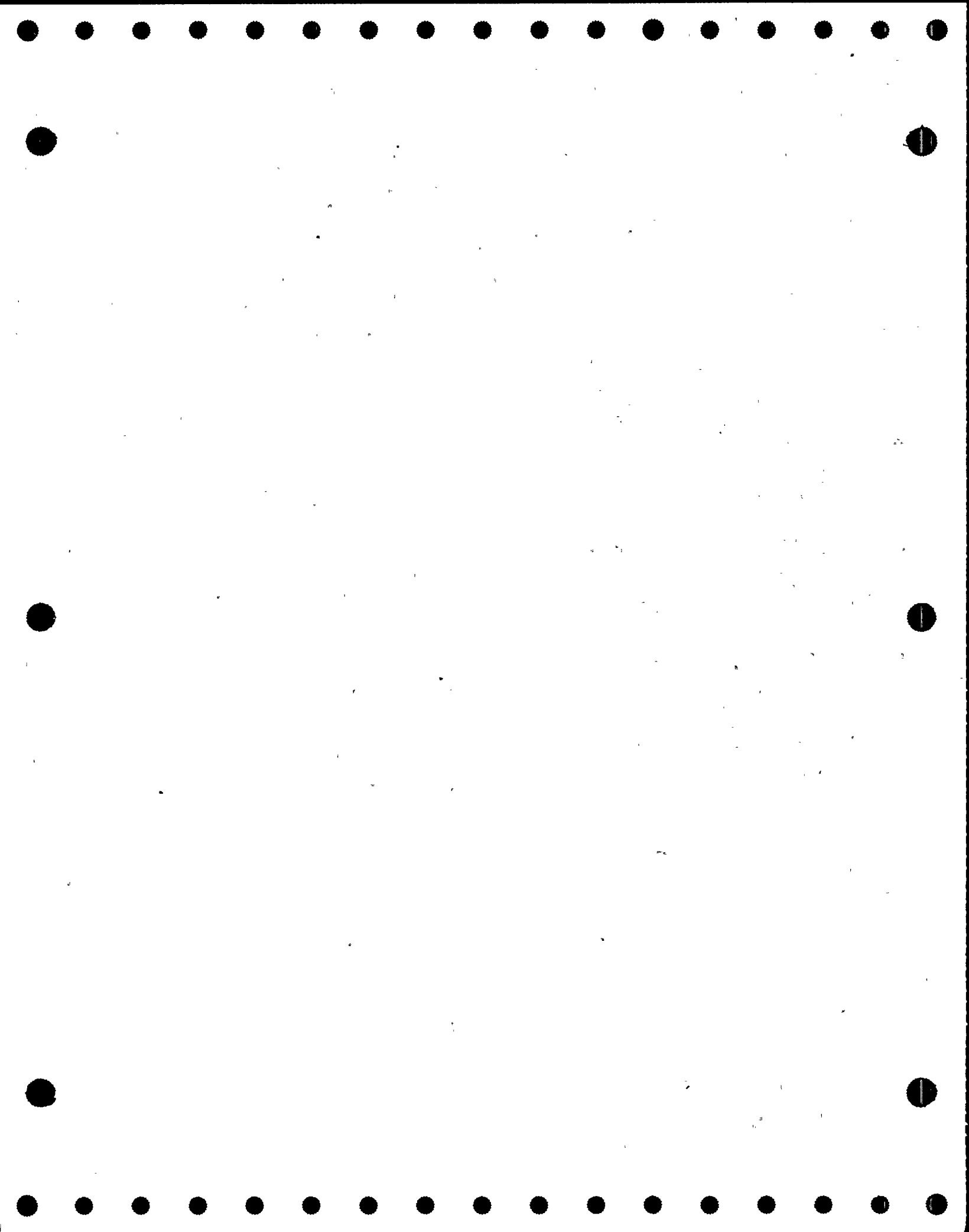

DONALD C. COOK NUCLEAR PLANT
 SECOND TEN YEAR INTERVAL
 VALVE SUMMARY SHEET - UNIT 1
 FLOW DIAGRAM: 1-5105D-1

RUN DATE AND TIME: 15FEB90:16:03

SYSTEM NAME: FEEDWATER

VALVE				VALVE POSITION				ASME SECTION XI						
NUMBER	REV	TYPE	SIZE	ACT TYPE	F.D. COORD	POWER OPER	SAFETY FUNCT	CD ICL	A/P	CAT	PRIM TEST REQUIRED	TEST PERFORMED	TEST MODE	RELIEF REQUEST(S)
1-FW-118-1	3	CK	14	SA	C/4	0	C	2	A	C	CF-1	CF-2	R	YES, NOTE 1
1-FW-118-2	3	CK	14	SA	K/4	0	C	2	A	C	CF-1	CF-2	R	YES, NOTE 1
1-FW-118-3	3	CK	14	SA	K/8	0	C	2	A	C	CF-1	CF-2	R	YES, NOTE 1
1-FW-118-4	3	CK	14	SA	B/9	0	C	2	A	C	CF-1	CF-2	R	YES, NOTE 1
1-MCM-221	3	GL	4	MO	K/4	0	O/C	2	A	B	EF-1 EF-5 ET-XXX	EF-1 EF-5 ET-XXX	P - P	NO NO NO
1-MCM-231	3	GL	4	MO	K/4	0	O/C	2	A	B	EF-1 EF-5 ET-XXX	EF-1 EF-5 ET-XXX	P - P	NO NO NO
1-MRV-210	3	GA	28	PO	B/3	0	C	2	A	B	EF-1 EF-5 EF-7 ET-XXX	EF-3 EF-5 EF-8 ET-XXX	P - C C	NO, CSJ 2 NO NO, CSJ 2 NO, CSJ 2
1-MRV-211	3	AG	2	A	A/1	C	0	2	A	B	EF-1 EF-5 EF-7 ET-XXX	EF-1 EF-5 EF-7 ET-XXX	P - P P	NO NO NO NO
1-MRV-212	3	AG	2	A	A/1	C	0	2	A	B	EF-1 EF-5 EF-7 ET-XXX	EF-1 EF-5 EF-7 ET-XXX	P - P P	NO NO NO NO

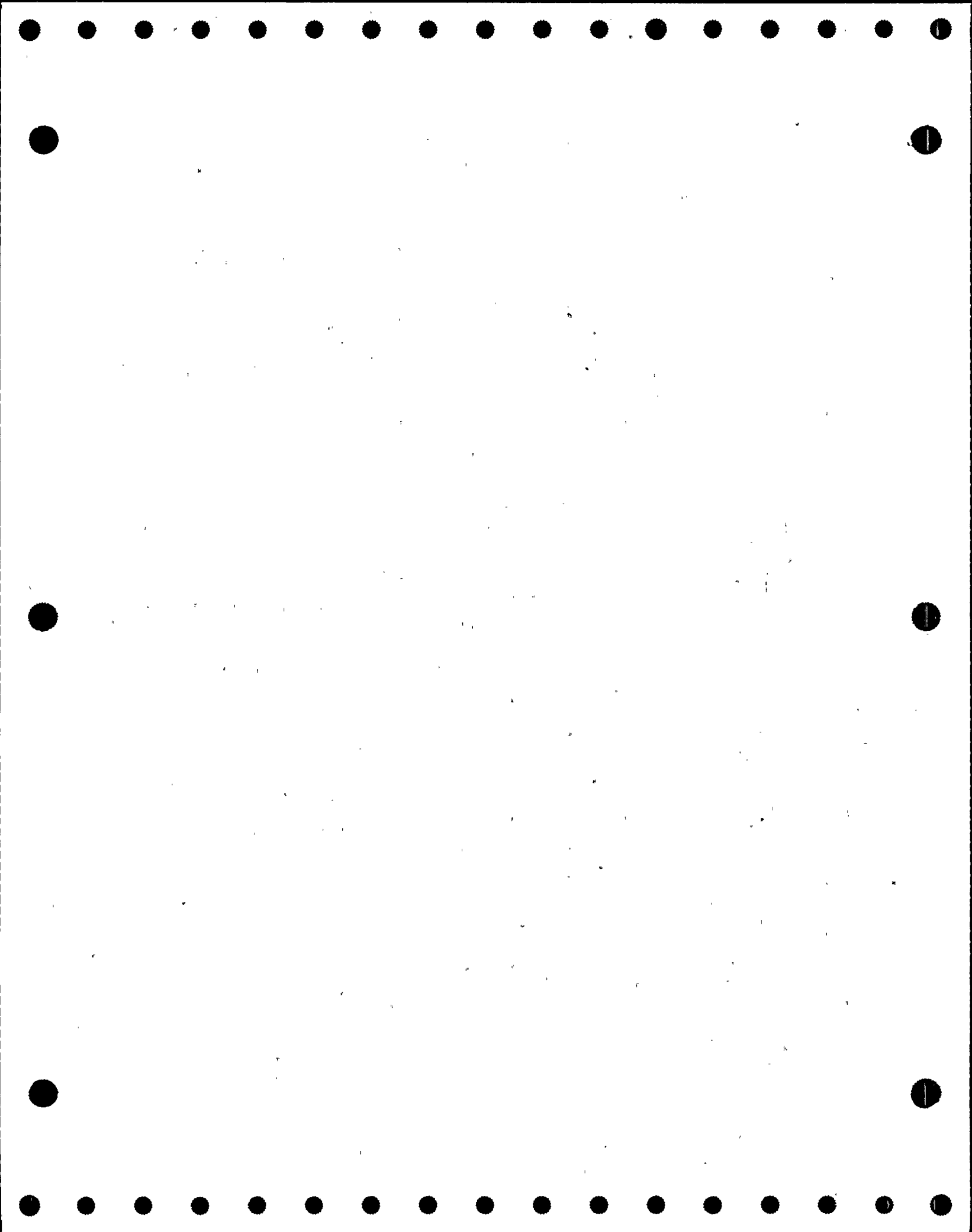

DONALD C. COOK NUCLEAR PLANT
 SECOND TEN YEAR INTERVAL
 VALVE SUMMARY SHEET - UNIT 1
 FLOW DIAGRAM: 1-5105D-1

RUN DATE AND TIME: 15FEB90:16:03

SYSTEM NAME: MAIN STEAM

VALVE				VALVE POSITION				ASME SECTION XI						
NUMBER	REV	TYPE	SIZE	ACT TYPE	F.D. COORD	POWER OPER	SAFETY FUNCT	CD ICL	A/P	CAT	PRIM TEST REQUIRED	TEST PERFORMED	TEST MODE	RELIEF REQUEST(S)
1-MRV-220	3	GA	28	PO	L/3	O	C	2	A	B	EF-1 EF-5 EF-7 ET-XXX	EF-3 EF-5 EF-8 ET-XXX	P - C P	NO, CSJ 2 NO NO, CSJ 2 NO, CSJ 2
1-MRV-221	3	AG	2	A	M/1	C	O	2	A	B	EF-1 EF-5 EF-7 ET-XXX	EF-1 EF-5 EF-7 ET-XXX	P - P P	NO NO NO NO
1-MRV-222	3	AG	2	A	M/1	C	O	2	A	B	EF-1 EF-5 EF-7 ET-XXX	EF-1 EF-5 EF-7 ET-XXX	P - P P	NO NO NO NO
1-MRV-230	3	GA	28	PO	L/7	O	C	2	A	B	EF-1 EF-5 EF-7 ET-XXX	EF-3 EF-5 EF-8 ET-XXX	P - C P	NO, CSJ 2 NO NO, CSJ 2 NO, CSJ 2
1-MRV-231	3	AG	2	A	M/5	C	O	2	A	B	EF-1 EF-5 EF-7 ET-XXX	EF-1 EF-5 EF-7 ET-XXX	P - P P	NO NO NO NO
1-MRV-232	3	AG	2	A	M/5	C	O	2	A	B	EF-1 EF-5 EF-7 ET-XXX	EF-1 EF-5 EF-7 ET-XXX	P - P P	NO NO NO NO

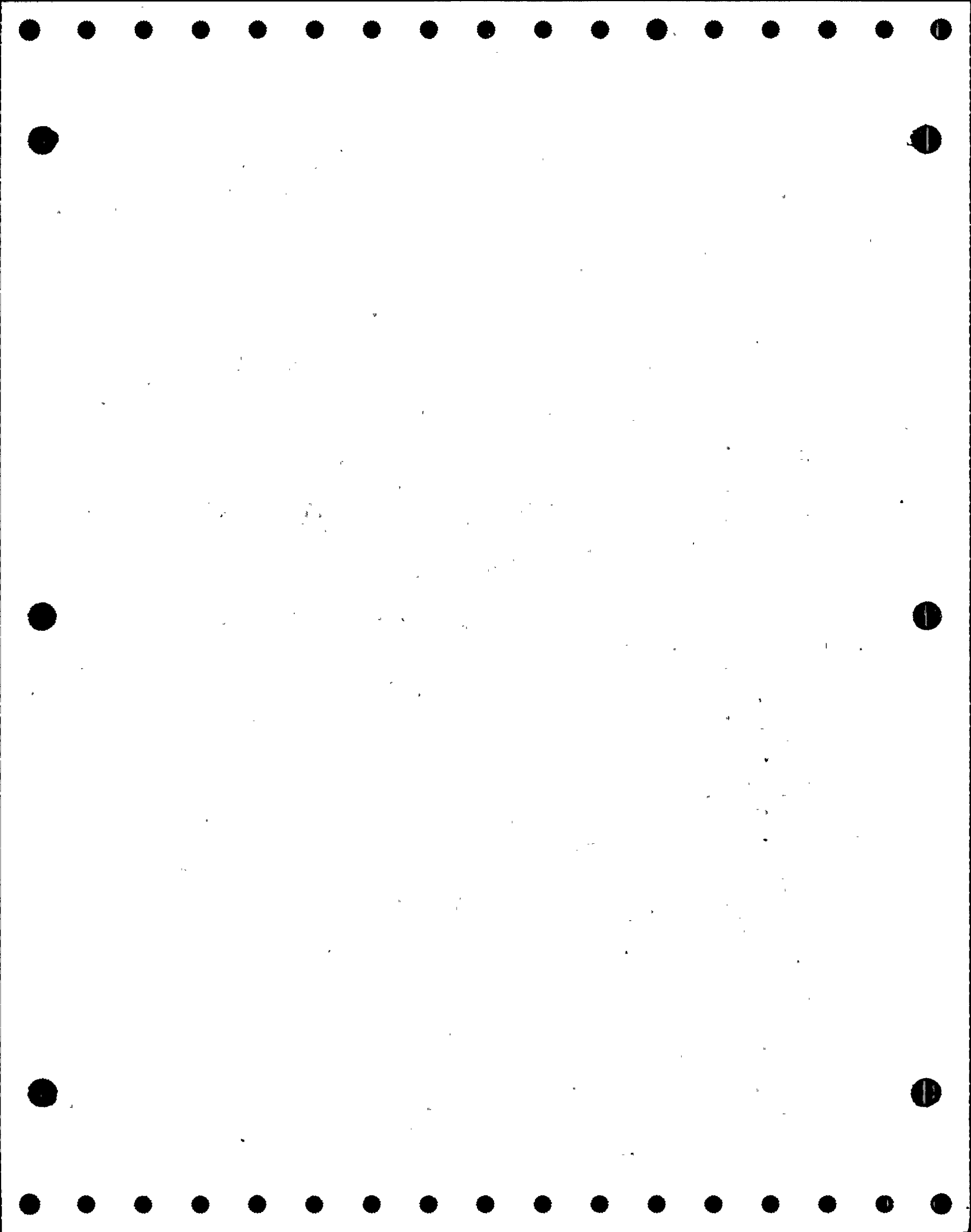

DONALD C. COOK NUCLEAR PLANT
 SECOND TEN YEAR INTERVAL
 VALVE SUMMARY SHEET - UNIT 1
 FLOW DIAGRAM: 1-5105D-1

RUN DATE AND TIME: 15FEB90:16:03

SYSTEM NAME: MAIN STEAM

VALVE				VALVE POSITION				ASME SECTION XI						
NUMBER	REV	TYPE	SIZE	ACT TYPE	F.D. COORD	POWER OPER	SAFETY FUNCT	CD ICL	A/P	CAT	PRIM TEST REQUIRED	TEST PERFORMED	TEST MODE	RELIEF REQUEST(S)
1-MRV-240	3	GA	28	PO	B/7	O	C	2	A	B	EF-1 EF-5 EF-7 ET-XXX	EF-3 EF-5 EF-8 ET-XXX	P - C C	NO, CSJ 2 NO NO, CSJ 2 NO, CSJ 2
1-MRV-241	3	AG	2	A	A/5	C	O	2	A	B	EF-1 EF-5 EF-7 ET-XXX	EF-1 EF-5 EF-7 ET-XXX	P - P P	NO NO NO NO
1-MRV-242	3	AG	2	A	A/5	C	O	2	A	B	EF-1 EF-5 EF-7 ET-XXX	EF-1 EF-5 EF-7 ET-XXX	P - P P	NO NO NO NO
1-MS-108-2	3	CK	4	SA	K/4	C	O/C	3	A	C	CF-1	CF-2	R	YES, NOTE 3
1-MS-108-3	3	CK	4	SA	K/4	C	O/C	3	A	C	CF-1	CF-2	R	YES, NOTE 3
1-SV-1A-1	3	REL	6	SA	C/1	C	O	2	A	C	TF-1	TF-1	R	NO
1-SV-1A-2	3	REL	6	SA	K/1	C	O	2	A	C	TF-1	TF-1	R	NO
1-SV-1A-3	3	REL	6	SA	K/5	C	O	2	A	C	TF-1	TF-1	R	NO
1-SV-1A-4	3	REL	6	SA	C/5	C	O	2	A	C	TF-1	TF-1	R	NO

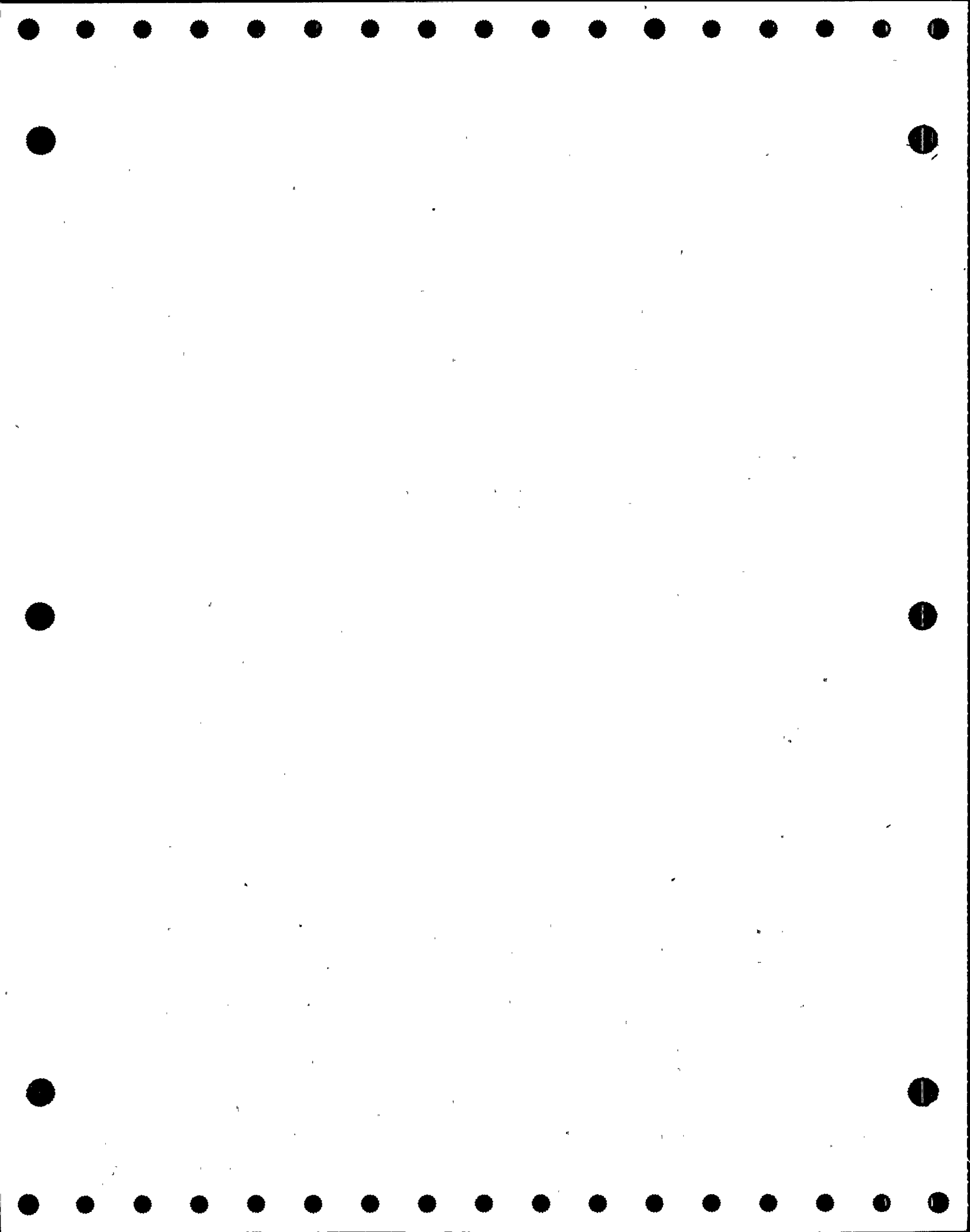

DONALD C. COOK NUCLEAR PLANT
 SECOND TEN YEAR INTERVAL
 VALVE SUMMARY SHEET - UNIT 1
 FLOW DIAGRAM: 1-5105D-1

RUN DATE AND TIME: 15FEB90:16:03

SYSTEM NAME: MAIN STEAM

VALVE				VALVE POSITION				ASME SECTION XI						
NUMBER	REV	TYPE	SIZE	ACT TYPE	F.D. COORD	POWER OPER	SAFETY FUNCT	CD ICL	A/P	CAT	PRIM TEST REQUIRED	TEST PERFORMED	TEST MODE	RELIEF REQUEST(S)
1-SV-1B-1	3	REL	6	SA	B/1	C	0	2	A	C	TF-1	TF-1	R	NO
1-SV-1B-2	3	REL	6	SA	L/1	C	0	2	A	C	TF-1	TF-1	R	NO
1-SV-1B-3	3	REL	6	SA	L/5	C	0	2	A	C	TF-1	TF-1	R	NO
1-SV-1B-4	3	REL	6	SA	B/5	C	0	2	A	C	TF-1	TF-1	R	NO
1-SV-2A-1	3	REL	6	SA	B/1	C	0	2	A	C	TF-1	TF-1	R	NO
1-SV-2A-2	3	REL	6	SA	L/1	C	0	2	A	C	TF-1	TF-1	R	NO
1-SV-2A-3	3	REL	6	SA	L/5	C	0	2	A	C	TF-1	TF-1	R	NO
1-SV-2A-4	3	REL	6	SA	B/5	C	0	2	A	C	TF-1	TF-1	R	NO
1-SV-2B-1	3	REL	6	SA	A/1	C	0	2	A	C	TF-1	TF-1	R	NO
1-SV-2B-2	3	REL	6	SA	L/1	C	0	2	A	C	TF-1	TF-1	R	NO
1-SV-2B-3	3	REL	6	SA	L/5	C	0	2	A	C	TF-1	TF-1	R	NO
1-SV-2B-4	3	REL	6	SA	B/5	C	0	2	A	C	TF-1	TF-1	R	NO

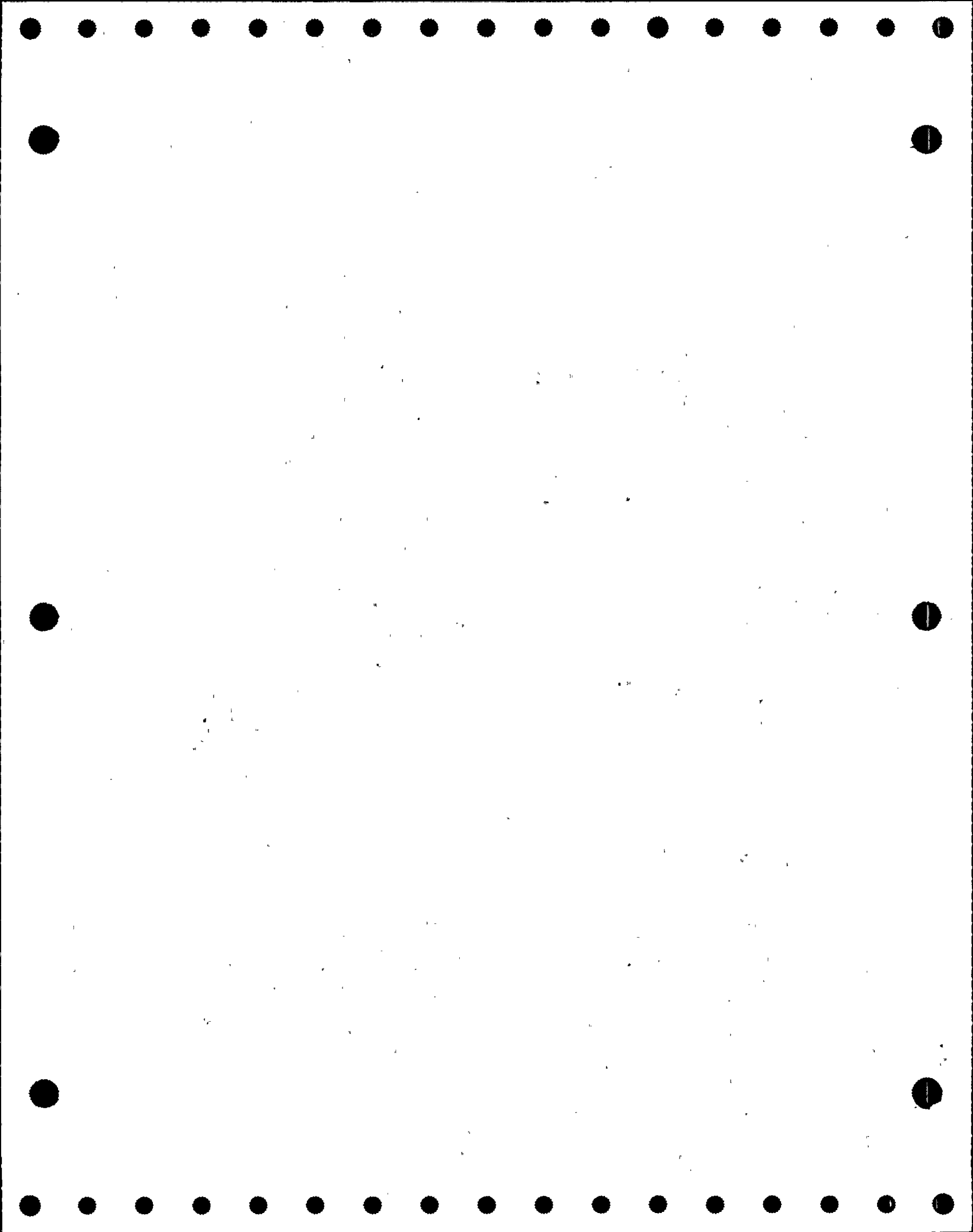

DONALD C. COOK NUCLEAR PLANT
 SECOND TEN YEAR INTERVAL
 VALVE SUMMARY SHEET - UNIT 1
 FLOW DIAGRAM: 1-5105D-1

RUN DATE AND TIME: 15FEB90:16:03

SYSTEM NAME: MAIN STEAM

VALVE				VALVE POSITION				ASME SECTION XI						
NUMBER	REV	TYPE	SIZE	ACT TYPE	F.D. COORD	POWER OPER	SAFETY FUNCT	CD ICL	A/P	CAT	PRIM TEST REQUIRED	TEST PERFORMED	TEST MODE	RELIEF REQUEST(S)
1-SV-3-1	3	REL	6	SA	A/1	C	0	2	A	C	TF-1	TF-1	R	NO
1-SV-3-2	3	REL	6	SA	L/1	C	0	2	A	C	TF-1	TF-1	R	NO
1-SV-3-3	3	REL	6	SA	L/5	C	0	2	A	C	TF-1	TF-1	R	NO
1-SV-3-4	3	REL	6	SA	A/5	C	0	2	A	C	TF-1	TF-1	R	NO

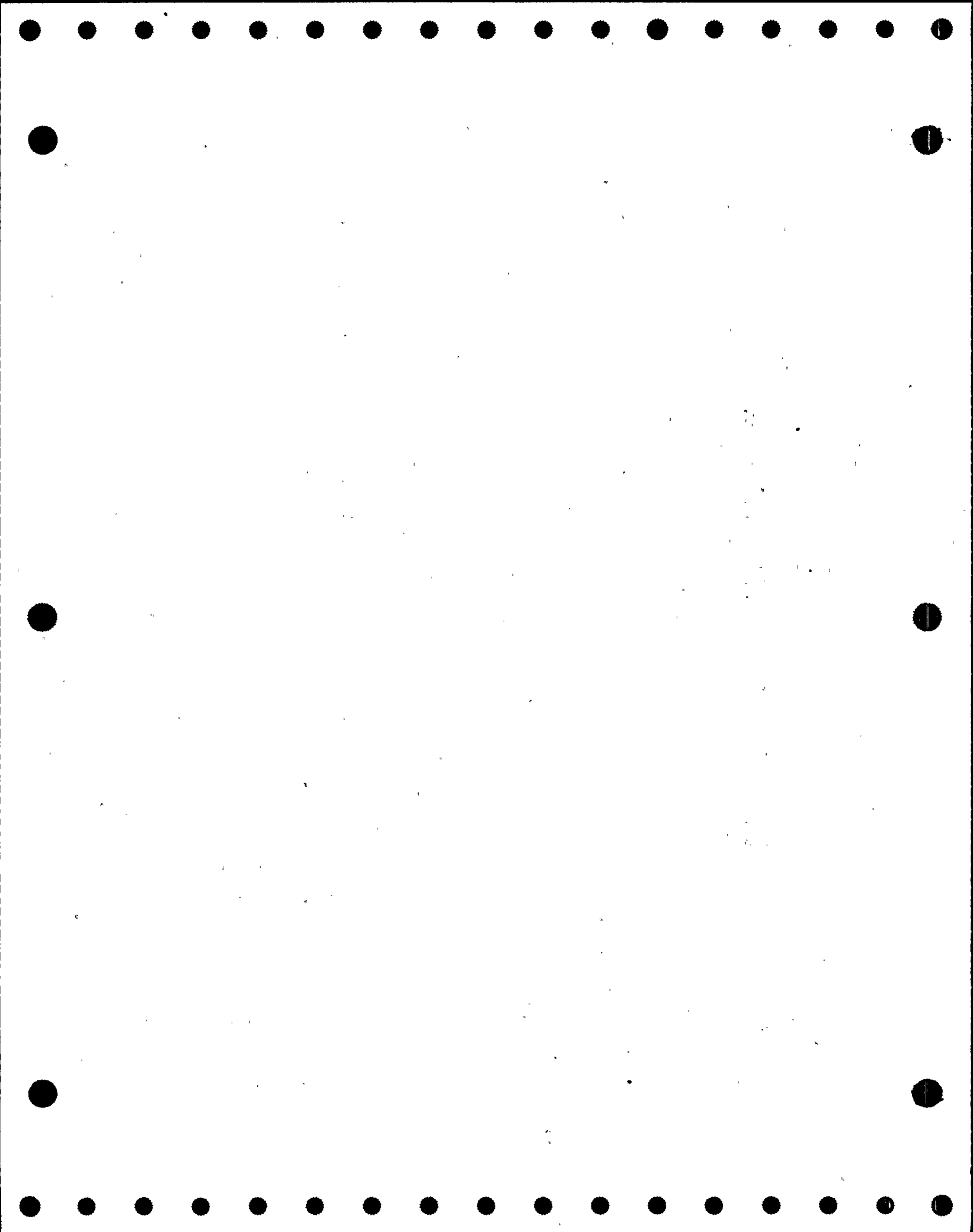

DONALD C. COOK NUCLEAR PLANT
 SECOND TEN YEAR INTERVAL
 VALVE SUMMARY SHEET - UNIT 1
 FLOW DIAGRAM: 1-5106-35

RUN DATE AND TIME: 15FEB90:16:03

SYSTEM NAME: FEEDWATER

VALVE				VALVE POSITION				ASME SECTION XI						
NUMBER	REV	TYPE	SIZE	ACT TYPE	F.D. COORD	POWER OPER	SAFETY FUNCT	CD ICL	A/P	CAT	PRIM TEST REQUIRED	TEST PERFORMED	TEST MODE	RELIEF REQUEST(S)
1-FMO-201	3	GA	14	MO	F/5	0	C	2	A	B	EF-1	EF-2	C	NO, CSJ 1
											EF-5	EF-5	-	NO
											ET-XXX	ET-XXX	C	NO, CSJ 1
1-FMO-202	3	GA	14	MO	F/9	0	C	2	A	B	EF-1	EF-2	C	NO, CSJ 1
											EF-5	EF-5	-	NO
											ET-XXX	ET-XXX	C	NO, CSJ 1
1-FMO-203	3	GA	14	MO	F/9	0	C	2	A	B	EF-1	EF-2	C	NO, CSJ 1
											EF-5	EF-5	-	NO
											ET-XXX	ET-XXX	C	NO, CSJ 1
1-FMO-204	3	GA	14	MO	G/5	0	C	2	A	B	EF-1	EF-2	C	NO, CSJ 1
											EF-5	EF-5	-	NO
											ET-XXX	ET-XXX	C	NO, CSJ 1
1-FRV-210	3	AG	14	A	G/5	0	C	2	A	B	EF-1	EF-2	C	NO, CSJ 1
											EF-5	EF-5	-	NO
											EF-7	EF-8	C	NO, CSJ 1
											ET-XXX	ET-XXX	C	NO, CSJ 1
1-FRV-220	3	AG	14	A	E/9	0	C	2	A	B	EF-1	EF-2	C	NO, CSJ 1
											EF-5	EF-5	-	NO
											EF-7	EF-8	C	NO, CSJ 1
											ET-XXX	ET-XXX	C	NO, CSJ 1
1-FRV-230	3	AG	14	A	G/9	0	C	2	A	B	EF-1	EF-2	C	NO, CSJ 1
											EF-5	EF-5	-	NO
											EF-7	EF-8	C	NO, CSJ 1
											ET-XXX	ET-XXX	C	NO, CSJ 1

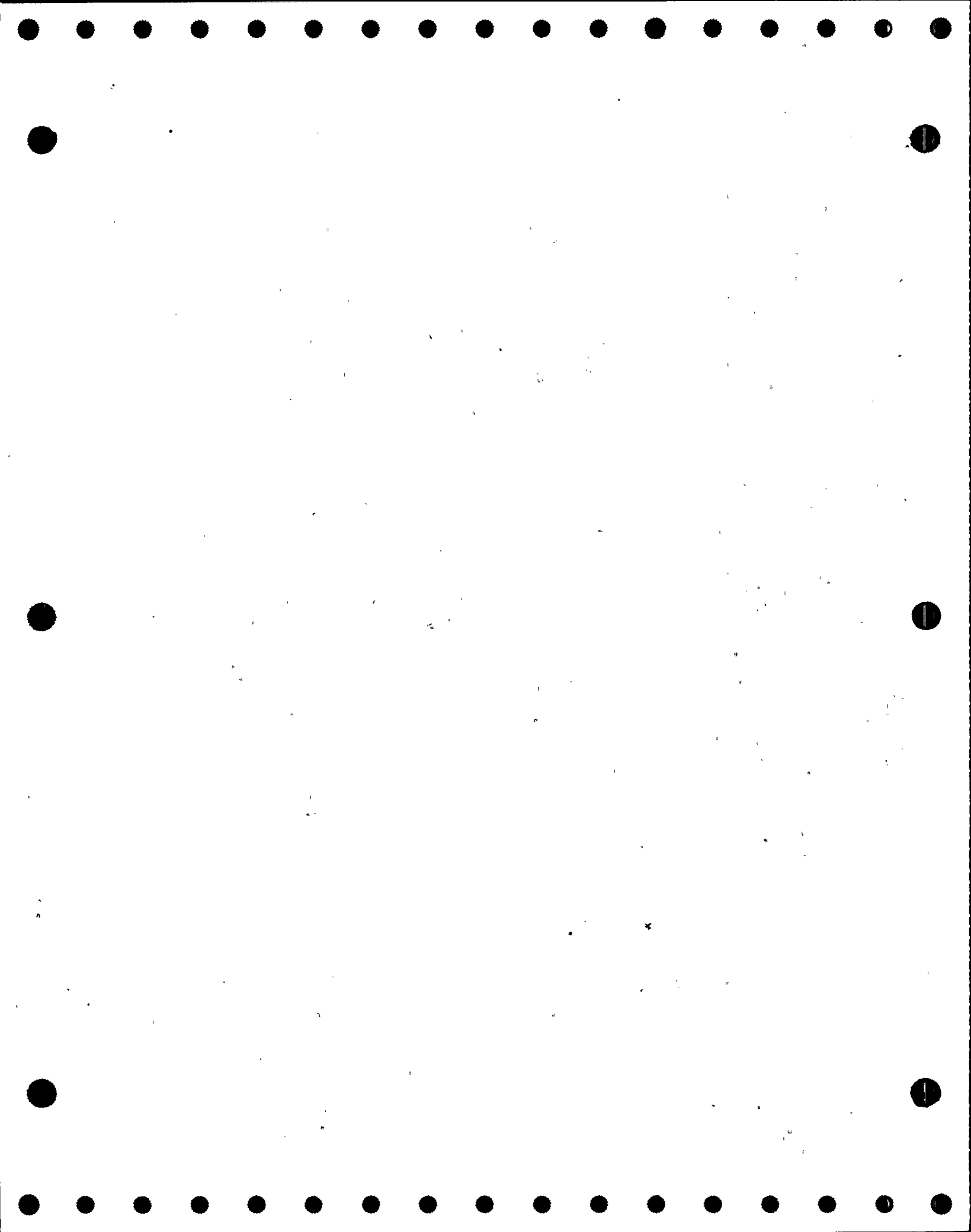

DONALD C. COOK NUCLEAR PLANT
 SECOND TEN YEAR INTERVAL
 VALVE SUMMARY SHEET - UNIT 1
 FLOW DIAGRAM: 1-5106-35

RUN DATE AND TIME: 15FEB90:16:03

SYSTEM NAME: FEEDWATER

VALVE				VALVE POSITION				ASME SECTION XI						
NUMBER	REV	TYPE	SIZE	ACT TYPE	F.D. COORD	POWER OPER	SAFETY FUNCT	CD ICL	A/P	CAT	PRIM TEST REQUIRED	TEST PERFORMED	TEST MODE	RELIEF REQUEST(S)
1-FRV-240	3	AG	14	A	H/5	O	C	2	A	B	EF-1 EF-5 EF-7 ET-XXX	EF-2 EF-5 EF-8 ET-XXX	C - C C	NO, CSJ 1 NO NO, CSJ 1 NO, CSJ 1

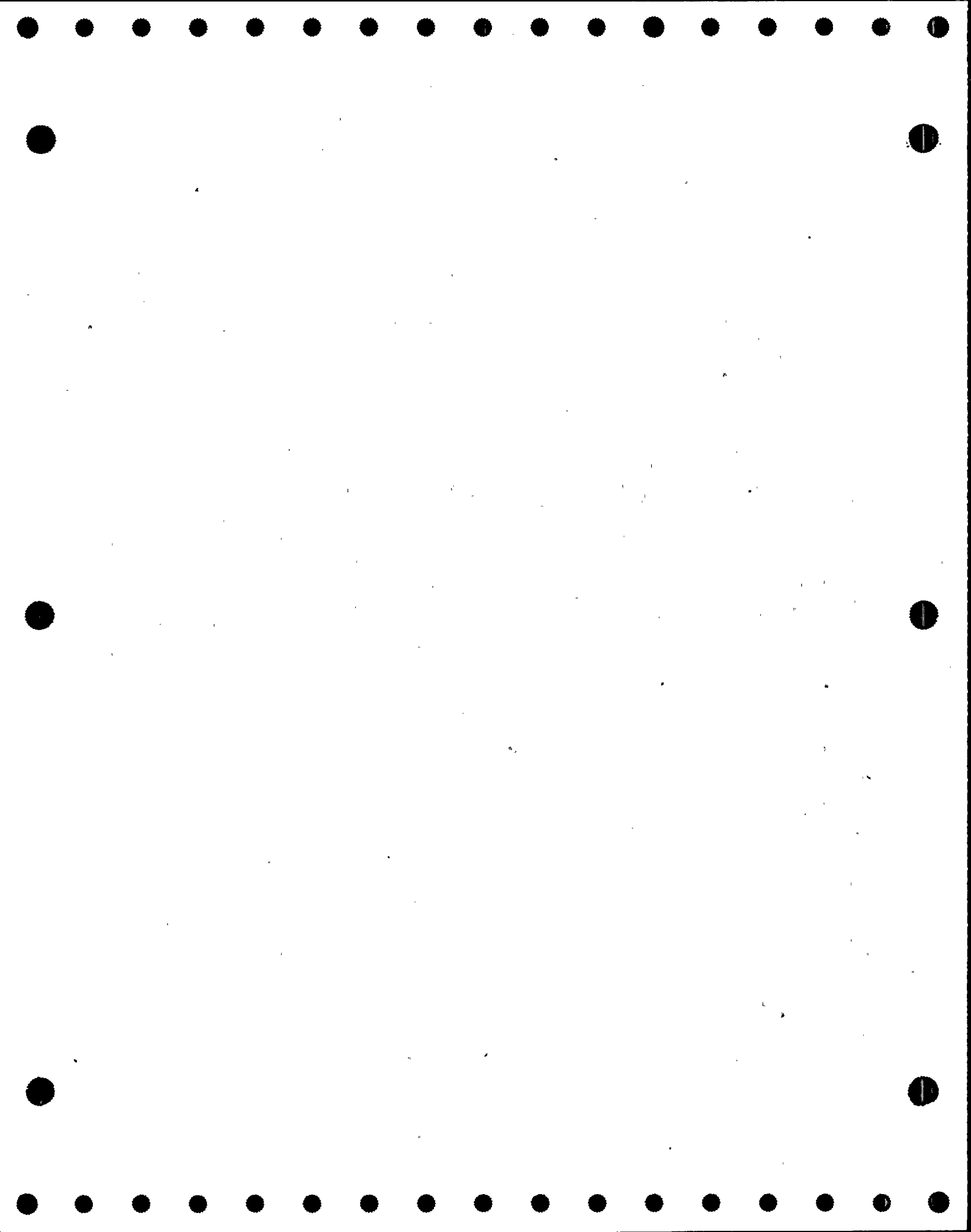

DONALD C. COOK NUCLEAR PLANT
 SECOND TEN YEAR INTERVAL
 VALVE SUMMARY SHEET - UNIT 1
 FLOW DIAGRAM: 1-5106A-38

RUN DATE AND TIME: 15FEB90:16:03

SYSTEM NAME: FEEDWATER

VALVE				VALVE POSITION				ASME SECTION XI						
NUMBER	REV	TYPE	SIZE	ACT TYPE	F.D. COORD	POWER OPER	SAFETY FUNCT	CD ICL	A/P	CAT	PRIM TEST REQUIRED	TEST PERFORMED	TEST MODE	RELIEF REQUEST(S)
1-FMO-211	3	GL	4	MO	J/4	0	0	3	A	B	EF-1 EF-5 ET-XXX	EF-1 EF-5 ET-XXX	P - P	NO NO NO
1-FMO-212	3	GL	4	MO	J/5	0	0	3	A	B	EF-1 EF-5 ET-XXX	EF-1 EF-5 ET-XXX	P - P	NO NO NO
1-FMO-221	3	GL	4	MO	F/5	0	0	3	A	B	EF-1 EF-5 ET-XXX	EF-1 EF-5 ET-XXX	P - P	NO NO NO
1-FMO-222	3	GL	4	MO	F/6	0	0	3	A	B	EF-1 EF-5 ET-XXX	EF-1 EF-5 ET-XXX	P - P	NO NO NO
1-FMO-231	3	GL	4	MO	F/5	0	0	3	A	B	EF-1 EF-5 ET-XXX	EF-1 EF-5 ET-XXX	P - P	NO NO NO
1-FMO-232	3	GL	4	MO	F/6	0	0	3	A	B	EF-1 EF-5 ET-XXX	EF-1 EF-5 ET-XXX	P - P	NO NO NO
1-FMO-241	3	GL	4	MO	J/5	0	0	3	A	B	EF-1 EF-5 ET-XXX	EF-1 EF-5 ET-XXX	P - P	NO NO NO

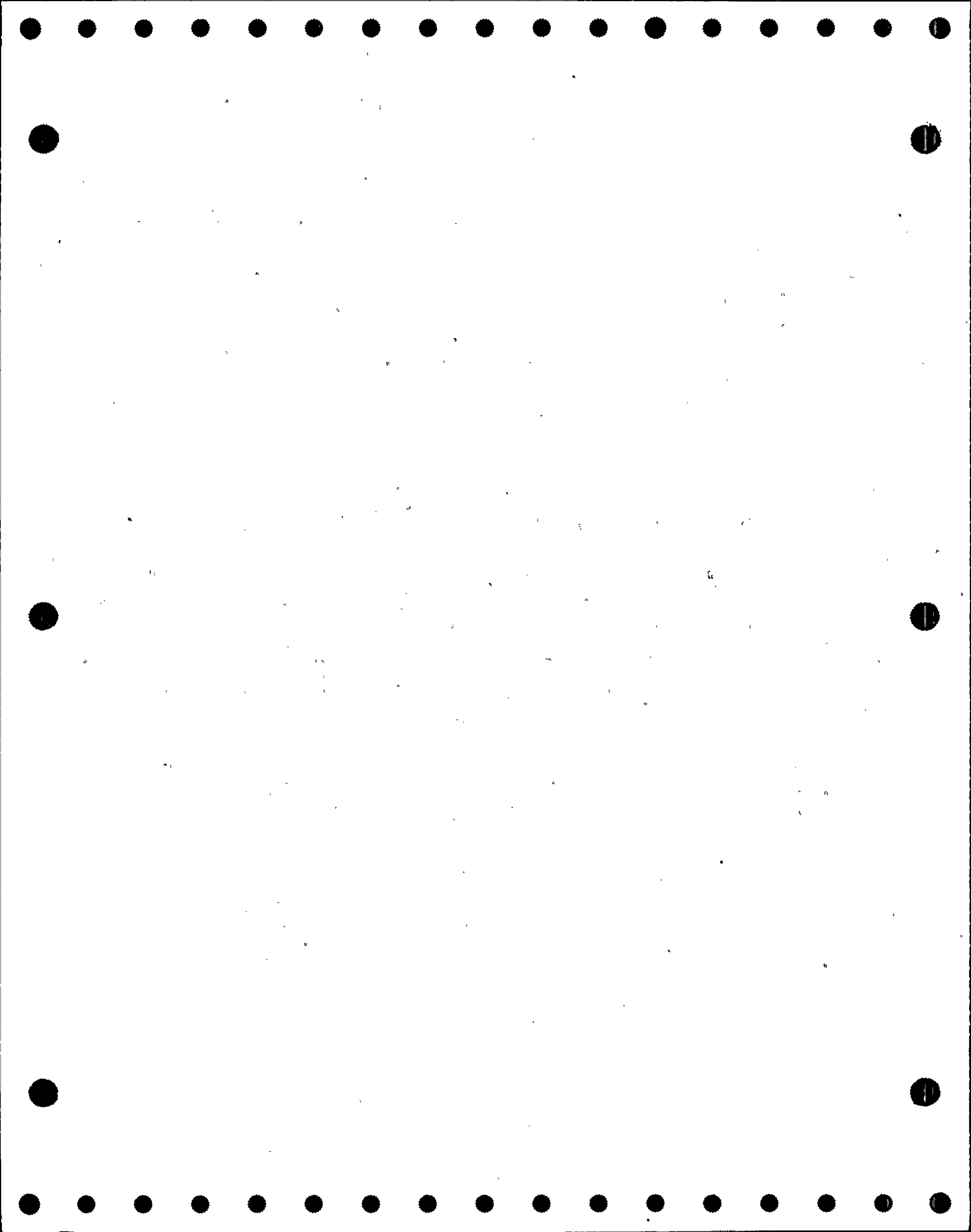

DONALD C. COOK NUCLEAR PLANT
 SECOND TEN YEAR INTERVAL
 VALVE SUMMARY SHEET - UNIT 1
 FLOW DIAGRAM: 1-5106A-38

RUN DATE AND TIME: 15FEB90:16:03

SYSTEM NAME: FEEDWATER

VALVE				VALVE POSITION				ASME SECTION XI						
NUMBER	REV	TYPE	SIZE	ACT TYPE	F.D. COORD	POWER OPER	SAFETY FUNCT	CD ICL	A/P	CAT	PRIM TEST REQUIRED	TEST PERFORMED	TEST MODE	RELIEF REQUEST(S)
1-FM0-242	3	GL	4	MO	J/5	0	0	3	A	B	EF-1 EF-5 ET-XXX	EF-1 EF-5 ET-XXX	P - P	NO NO NO
1-FRV-247	3	GL	1	A	C/8	0	C/O	3	A	B	EF-1 EF-5 EF-7 ET-XXX	EF-1 EF-5 EF-7 ET-XXX	P - P P	NO NO NO NO
1-FRV-257	3	GL	1	A	F/8	0	C/O	3	A	B	EF-1 EF-5 EF-7 ET-XXX	EF-1 EF-5 EF-7 ET-XXX	P - P P	NO NO NO NO
1-FRV-258	3	GL	1	A	J/9	0	C/O	3	A	B	EF-1 EF-5 EF-7 ET-XXX	EF-1 EF-5 EF-7 ET-XXX	P - P P	NO NO NO NO
1-FW-124	3	CK	8	SA	H/7	C	0	3	A	C	CF-1	CF-1	P	NO
1-FW-128	3	CK	6	SA	F/7	C	0	3	A	C	CF-1	CF-1	P	NO
1-FW-132-1	3	CK	4	SA	H/5	C	O/C	2	A	C	CF-1	CF-2	-	NO, CSJ 1
1-FW-132-2	3	CK	4	SA	F/6	C	O/C	2	A	C	CF-1	CF-2	-	NO, CSJ 1

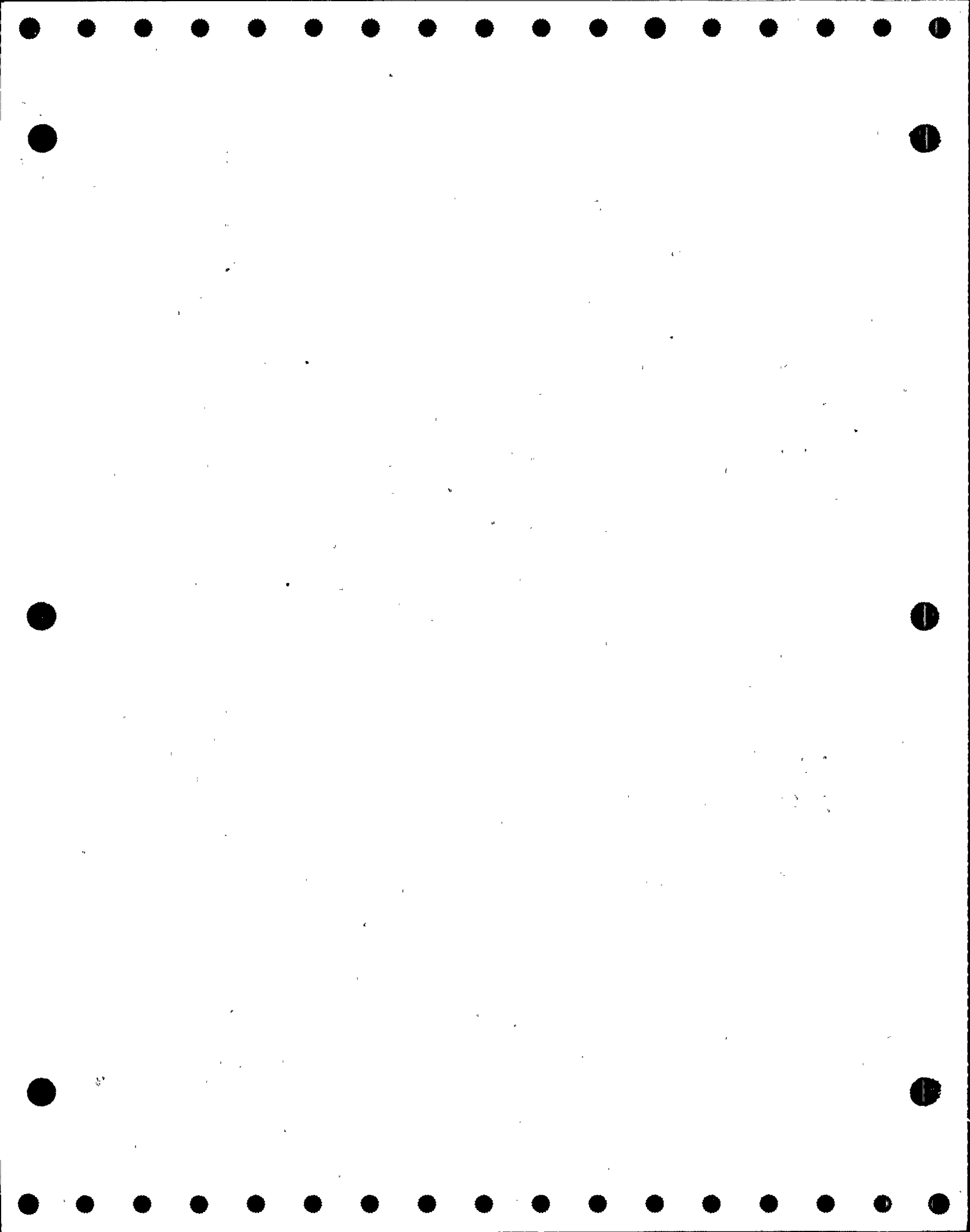

DONALD C. COOK NUCLEAR PLANT
 SECOND TEN YEAR INTERVAL
 VALVE SUMMARY SHEET - UNIT 1
 FLOW DIAGRAM: 1-5106A-38

RUN DATE AND TIME: 15FEB90:16:03

SYSTEM NAME: FEEDWATER

VALVE				VALVE POSITION				ASME SECTION XI						
NUMBER	REV	TYPE	SIZE	ACT TYPE	F.D. COORD	POWER OPER	SAFETY FUNCT	CD ICL	A/P	CAT	PRIM TEST REQUIRED	TEST PERFORMED	TEST MODE	RELIEF REQUEST(S)
1-FW-132-3	3	CK	4	SA	F/6	C	O/C	2	A	C	CF-1	CF-2	-	NO, CSJ 1
1-FW-132-4	3	CK	4	SA	H/5	C	O/C	2	A	C	CF-1	CF-2	-	NO, CSJ 1
1-FW-134	3	CK	10	SA	L/9	C	0	3	A	C	CF-1	CF-3	C	NO, CSJ 2
1-FW-135	3	CK	8	SA	J/8	C	0	3	A	C	CF-1	CF-3	C	NO, CSJ 2
1-FW-138-1	3	CK	4	SA	H/4	C	O/C	2	A	C	CF-1	CF-2	-	NO, CSJ 3
1-FW-138-2	3	CK	4	SA	F/5	C	O/C	2	A	C	CF-1	CF-2	-	NO, CSJ 3
1-FW-138-3	3	CK	4	SA	F/5	C	O/C	2	A	C	CF-1	CF-2	-	NO, CSJ 3
1-FW-138-4	3	CK	4	SA	H/4	C	O/C	2	A	C	CF-1	CF-2	-	NO, CSJ 3
1-FW-149	3	CK	0.75	SA	L/3	C	0	3	A	C	CF-1	CF-1	P	NO, NOTE 4
1-FW-150	3	CK	0.75	SA	L/4	C	0	3	A	C	CF-1	CF-1	P	NO, NOTE 4
1-FW-153	3	CK	1	SA	F/8	C	O/C	3	A	C	CF-1	CF-1	P	NO, NOTE 5
1-FW-159	3	CK	6	SA	C/7	C	0	3	A	C	CF-1	CF-1	P	NO

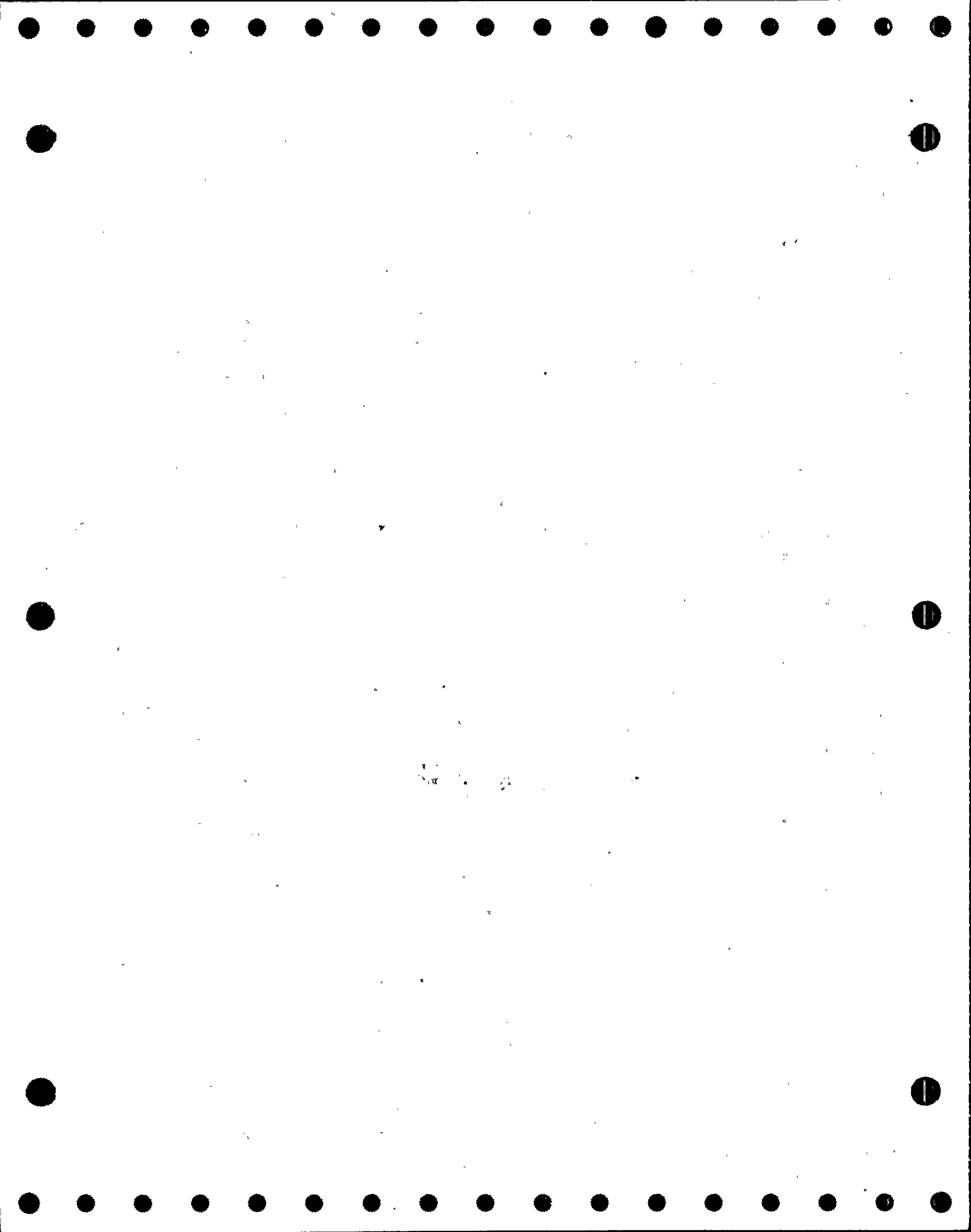

DONALD C. COOK NUCLEAR PLANT
 SECOND TEN YEAR INTERVAL
 VALVE SUMMARY SHEET - UNIT 1
 FLOW DIAGRAM: 1-5106A-38

RUN DATE AND TIME: 15FEB90:16:03

SYSTEM NAME: FEEDWATER

VALVE				VALVE POSITION				ASME SECTION XI						
NUMBER	REV	TYPE	SIZE	ACT TYPE	F.D. COORD	POWER OPER	SAFETY FUNCT	CD ICL	A/P	CAT	PRIM TEST REQUIRED	TEST PERFORMED	TEST MODE	RELIEF REQUEST(S)
1-FW-160	3	CK	1	SA	C/8	C	O/C	3	A	C	CF-1	CF-1	P	NO, NOTE 5
1-FW-161	3	CK	8	SA	E/7	C	0	3	A	C	CF-1	CF-1	P	NO
1-SV-140-A	3	REL	0.75	SA	M/2	C	0	3	A	C	TF-1	TF-1	R	NO
1-SV-140-B	3	REL	0.75	SA	L/2	C	0	3	A	C	TF-1	TF-1	R	NO
1-SV-169-A	3	REL	0.75	SA	D/8	C	0	3	A	C	TF-1	TF-1	R	NO
1-SV-169-B	3	REL	0.75	SA	G/8	C	0	3	A	C	TF-1	TF-1	R	NO
12-CRV-51	3	GL	8	A	M/8	O/C	C	3	A	B	EF-1 EF-5 EF-7 ET-XXX	EF-1 EF-5 EF-7 ET-XXX	- - - -	NO NO NO NO

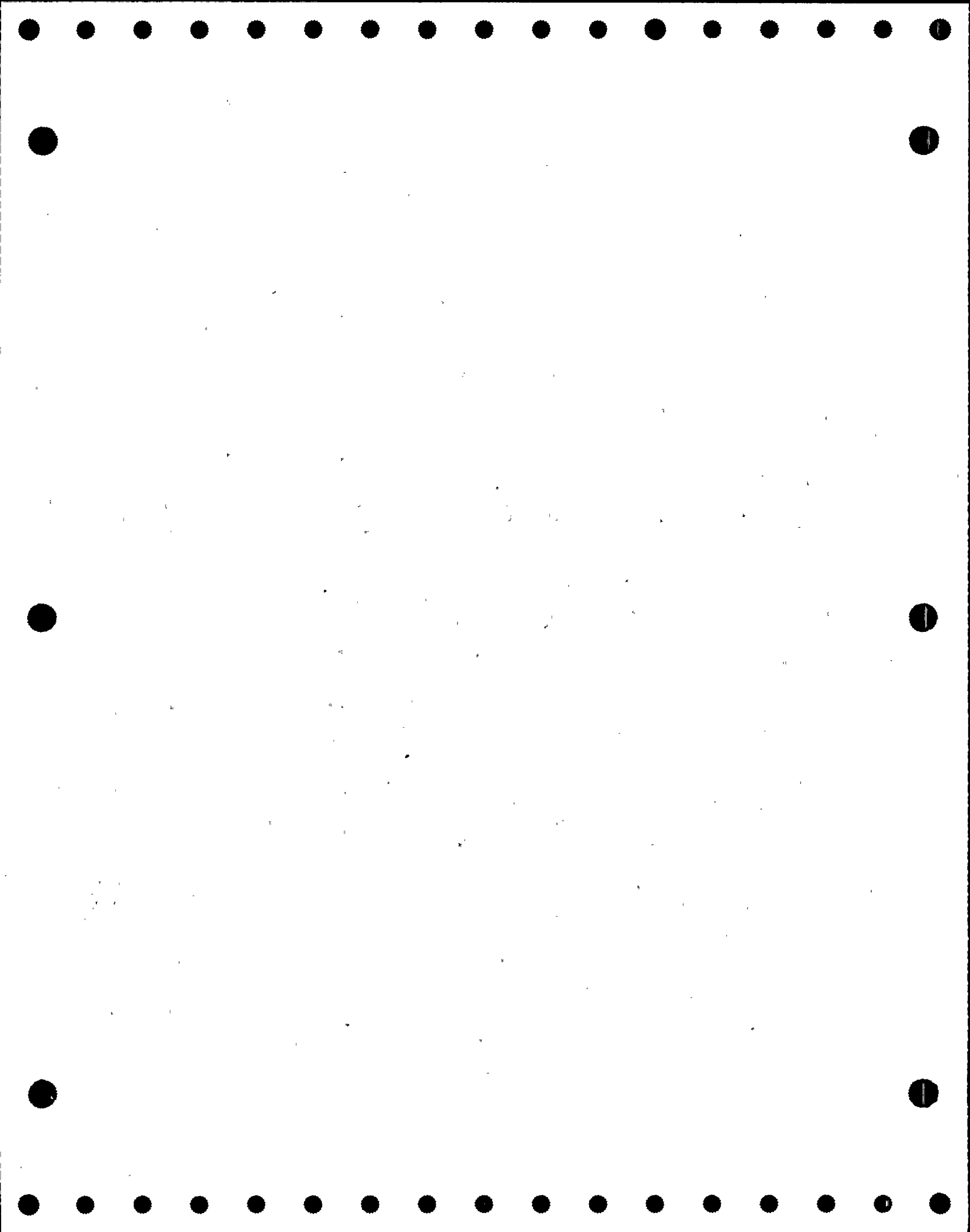

DONALD C. COOK NUCLEAR PLANT
 SECOND TEN YEAR INTERVAL
 VALVE SUMMARY SHEET - UNIT 1
 FLOW DIAGRAM: 1-5113-41

RUN DATE AND TIME: 15FEB90:16:03

SYSTEM NAME: ESSENTIAL SERVICE WATER

VALVE				VALVE POSITION				ASME SECTION XI						
NUMBER	REV	TYPE	SIZE	ACT TYPE	F.D. COORD	POWER OPER	SAFETY FUNCT	CD ICL	A/P	CAT	PRIM TEST REQUIRED	TEST PERFORMED	TEST MODE	RELIEF REQUEST(S)
1-ESW-101-E	3	CK	20	SA	N/8	C	0	3	A	C	CF-1	CF-1	P	NO
1-ESW-101-W	3	CK	20	SA	H/8	C	0	3	A	C	CF-1	CF-1	P	NO
1-ESW-109	3	BF	4	M	B/5	C	0	3	A	B	EF-1	EF-2	C	NO, CSJ 2
1-ESW-111	3	CK	6	SA	C/6	C	0	3	A	C	CF-1	CF-1	P	NO, NOTE 1
1-ESW-112	3	CK	6	SA	C/6	C	0	3	A	C	CF-1	CF-1	P	NO, NOTE 1
1-ESW-113	3	CK	6	SA	B/6	C	0	3	A	C	CF-1	CF-1	P	NO, NOTE 1
1-ESW-114	3	CK	6	SA	B/6	C	0	3	A	C	CF-1	CF-1	P	NO, NOTE 1
1-ESW-115	3	BF	6	M	E/6	C	0	3	A	B	EF-1	EF-2	C	NO, CSJ 2
1-ESW-168-N	3	BF	3	M	H/1	C	0	3	A	B	EF-1	EF-1	P	NO
1-ESW-168-S	3	BF	3	M	H/1	C	0	3	A	B	EF-1	EF-1	P	NO
1-ESW-169-N	3	BF	3	M	G/1	O	C	3	A	B	EF-1	EF-1	P	NO
1-ESW-169-S	3	BF	3	M	G/1	O	C	3	A	B	EF-1	EF-1	P	NO

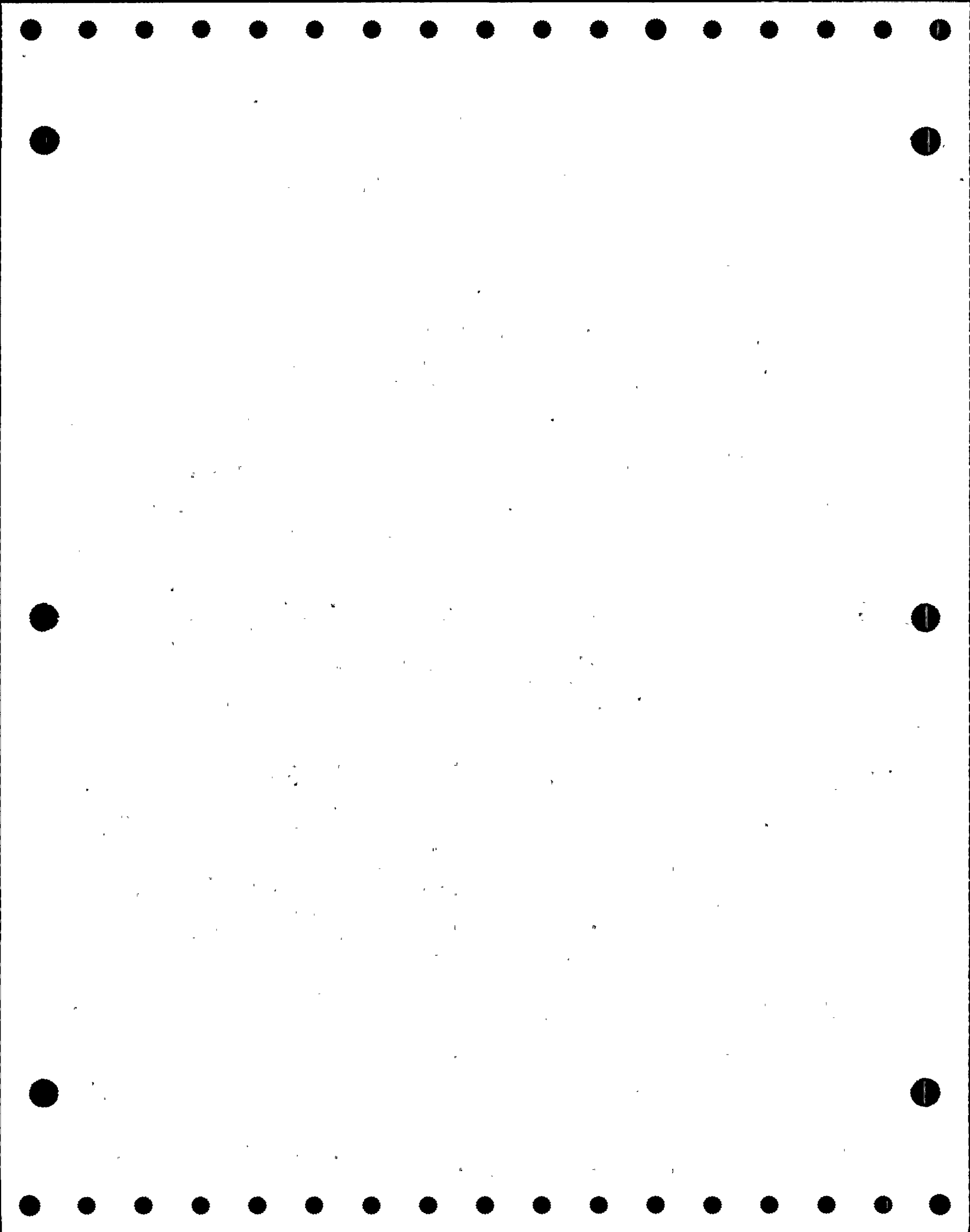

DONALD C. COOK NUCLEAR PLANT
 SECOND TEN YEAR INTERVAL
 VALVE SUMMARY SHEET - UNIT 1
 FLOW DIAGRAM: 1-5113-41

RUN DATE AND TIME: 15FEB90:16:03

SYSTEM NAME: ESSENTIAL SERVICE WATER

VALVE				VALVE POSITION				ASME SECTION XI						
NUMBER	REV	TYPE	SIZE	ACT TYPE	F.D. COORD	POWER OPER	SAFETY FUNCT	CD ICL	A/P	CAT	PRIM TEST REQUIRED	TEST PERFORMED	TEST MODE	RELIEF REQUEST(S)
1-ESW-170-N	3	BF	3	M	F/1	O	C	3	A	B	EF-1	EF-1	P	NO
1-ESW-170-S	3	BF	3	M	F/1	O	C	3	A	B	EF-1	EF-1	P	NO
1-ESW-171-N	3	BF	3	M	F/1	C	O	3	A	B	EF-1	EF-1	P	NO
1-ESW-171-S	3	BF	3	M	F/1	C	O	3	A	B	EF-1	EF-1	P	NO
1-ESW-243	3	BF	4	M	D/6	C	O	3	A	B	EF-1	EF-2	C	NO, CSJ 2
1-SV-14-E	3	REL	1	SA	A/1	C	O	3	A	C	TF-1	TF-1	R	NO
1-SV-14-W	3	REL	1	SA	C/1	C	O	3	A	C	TF-1	TF-1	R	NO
1-SV-15-E	3	REL	0.75	SA	E/4	C	O	3	A	C	TF-1	TF-1	R	NO
1-SV-15-W	3	REL	0.75	SA	G/4	C	O	3	A	C	TF-1	TF-1	R	NO
1-SV-16-AB	3	REL	1	SA	C/8	C	O	3	A	C	TF-1	TF-1	R	NO
1-SV-16-CD	3	REL	1	SA	C/8	C	O	3	A	C	TF-1	TF-1	R	NO
1-WMO-701	3	BF	20	MO	N/8	C	O	3	A	B	EF-1 EF-5 ET-XXX	EF-1 EF-5 ET-XXX	P - P	NO NO NO

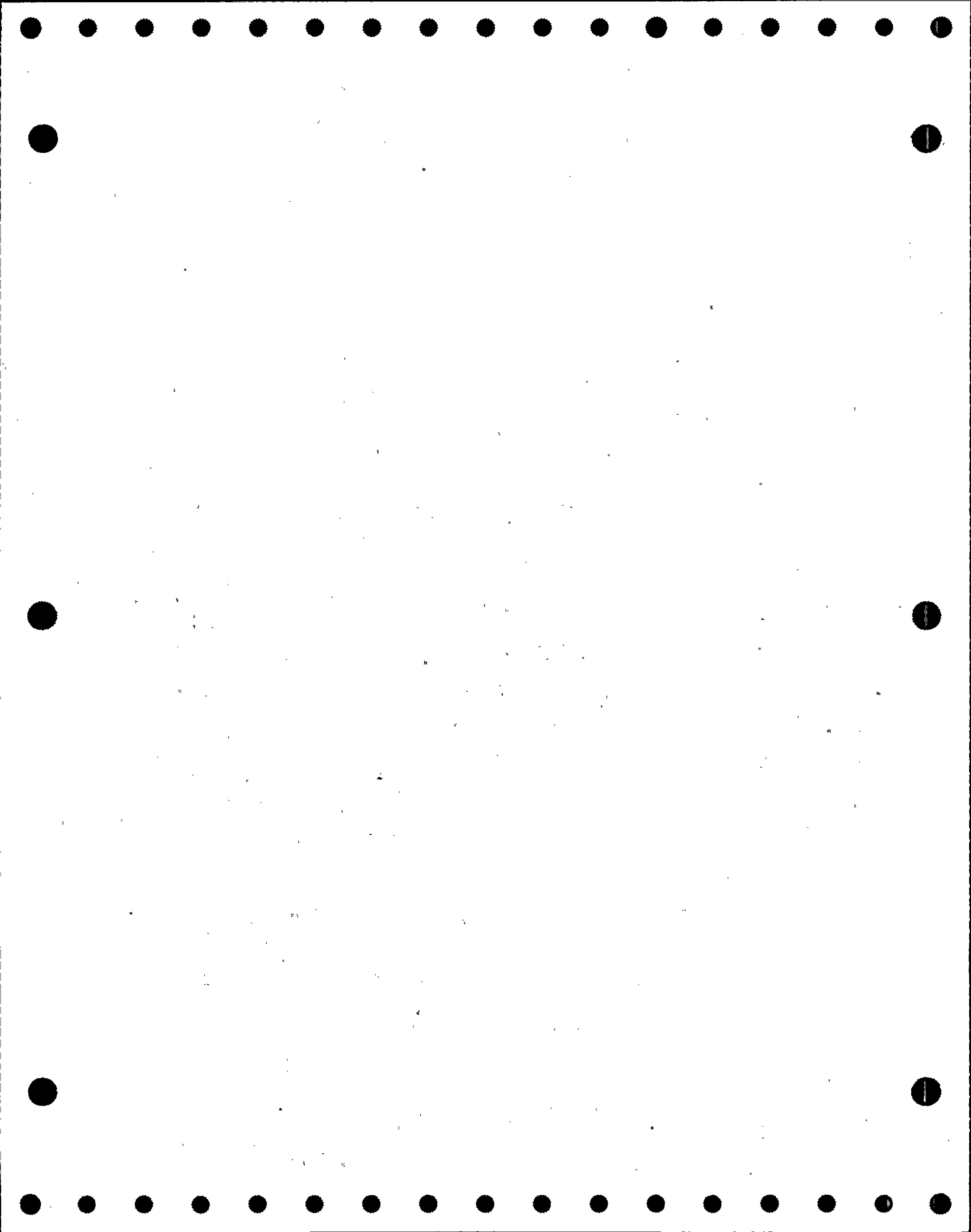

DONALD C. COOK NUCLEAR PLANT
 SECOND TEN YEAR INTERVAL
 VALVE SUMMARY SHEET - UNIT 1
 FLOW DIAGRAM: 1-5113-41

RUN DATE AND TIME: 15FEB90:16:03

SYSTEM NAME: ESSENTIAL SERVICE WATER

VALVE				VALVE POSITION				ASME SECTION XI						
NUMBER	REV	TYPE	SIZE	ACT TYPE	F.D. COORD	POWER OPER	SAFETY FUNCT	CD ICL	A/P	CAT	PRIM TEST REQUIRED	TEST PERFORMED	TEST MODE	RELIEF REQUEST(S)
1-WMO-702	3	BF	20	MO	H/8	C	O	3	A	B	EF-1 EF-5 ET-XXX	EF-1 EF-5 ET-XXX	P - P	NO NO NO
1-WMO-705	3	BF	20	MO	G/6	O	O/C	3	A	B	EF-1 EF-5 ET-XXX	EF-1 EF-5 ET-XXX	P - P	NO NO NO
1-WMO-707	3	BF	20	MO	G/7	O	O/C	3	A	B	EF-1 EF-5 ET-XXX	EF-1 EF-5 ET-XXX	P - P	NO NO NO
1-WMO-713	3	BF	12	MO	A/5	C	O	3	A	B	EF-1 EF-5 ET-XXX	EF-1 EF-5 ET-XXX	P - P	NO NO NO
1-WMO-717	3	BF	12	MO	B/5	C	O	3	A	B	EF-1 EF-5 ET-XXX	EF-1 EF-5 ET-XXX	P - P	NO NO NO
1-WMO-721	3	BF	6	MO	D/6	C	O	3	A	B	EF-1 EF-5 ET-XXX	EF-1 EF-5 ET-XXX	P - P	NO NO NO
1-WMO-723	3	BF	6	MO	C/6	C	O	3	A	B	EF-1 EF-5 ET-XXX	EF-1 EF-5 ET-XXX	P - P	NO NO NO

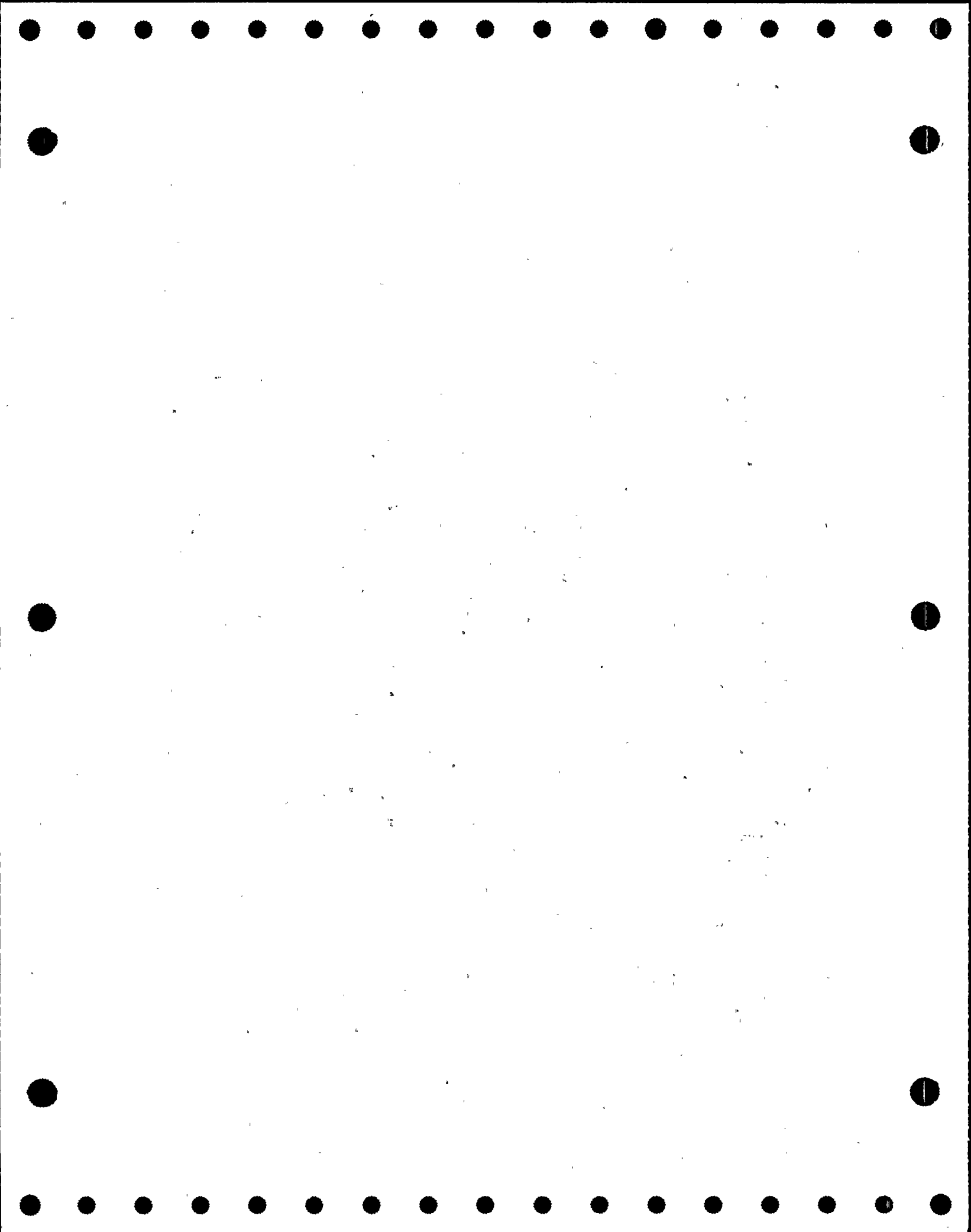

DONALD C. COOK NUCLEAR PLANT
 SECOND TEN YEAR INTERVAL
 VALVE SUMMARY SHEET - UNIT 1
 FLOW DIAGRAM: 1-5113-41

RUN DATE AND TIME: 15FEB90:16:03

SYSTEM NAME: ESSENTIAL SERVICE WATER

VALVE				VALVE POSITION				ASME SECTION XI						
NUMBER	REV	TYPE	SIZE	ACT TYPE	F.D. COORD	POWER OPER	SAFETY FUNCT	CD ICL	A/P	CAT	PRIM TEST REQUIRED	TEST PERFORMED	TEST MODE	RELIEF REQUEST(S)
1-WMO-725	3	BF	6	MO	B/6	C	0	3	A	B	EF-1 EF-5 ET-XXX	EF-1 EF-5 ET-XXX	P - P	NO NO NO
1-WMO-727	3	BF	6	MO	B/6	C	0	3	A	B	EF-1 EF-5 ET-XXX	EF-1 EF-5 ET-XXX	P - P	NO NO NO
1-WMO-733	3	BF	16	MO	C/3	O/C	0	3	A	B	EF-1 EF-5 ET-XXX	EF-1 EF-5 ET-XXX	P - P	NO NO NO
1-WMO-737	3	BF	16	MO	E/3	O/C	0	3	A	B	EF-1 EF-5 ET-XXX	EF-1 EF-5 ET-XXX	P - P	NO NO NO
1-WMO-744	3	BF	4	MO	D/6	C	0	3	A	B	EF-1 EF-5 ET-XXX	EF-1 EF-5 ET-XXX	P - P	NO NO NO
1-WMO-753	3	BF	6	MO	D/6	C	0	3	A	B	EF-1 EF-5 ET-XXX	EF-1 EF-5 ET-XXX	P - P	NO NO NO
1-WMO-754	3	BF	4	MO	B/5	C	0	3	A	B	EF-1 EF-5 ET-XXX	EF-1 EF-5 ET-XXX	P - P	NO NO NO

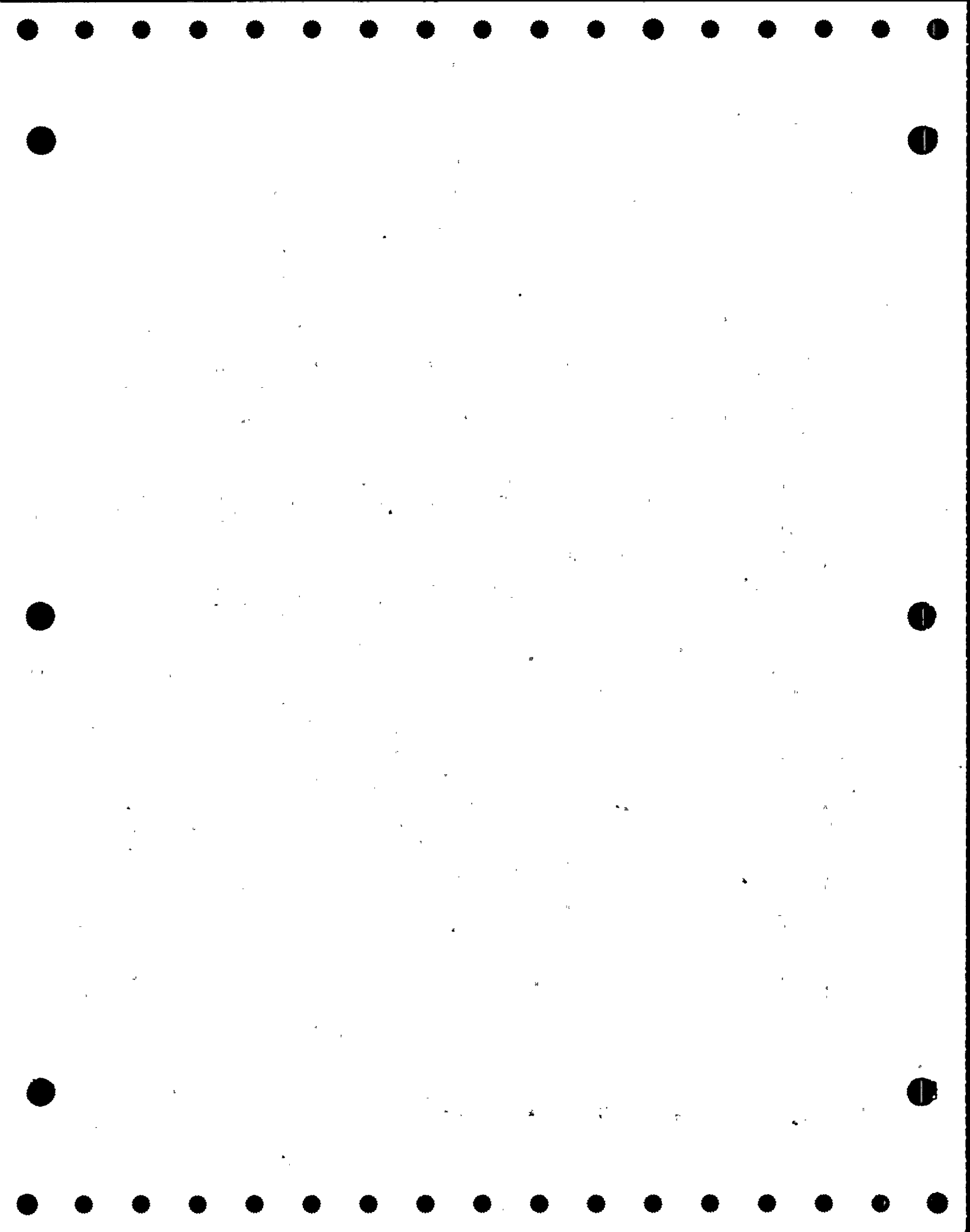

DONALD C. COOK NUCLEAR PLANT
 SECOND TEN YEAR INTERVAL
 VALVE SUMMARY SHEET - UNIT 1
 FLOW DIAGRAM: 1-5113-41

RUN DATE AND TIME: 15FEB90:16:03

SYSTEM NAME: ESSENTIAL SERVICE WATER

VALVE				VALVE POSITION				ASME SECTION XI						
NUMBER	REV	TYPE	SIZE	ACT TYPE	F.D. COORD	POWER OPER	SAFETY FUNCT	CD ICL	A/P	CAT	PRIM TEST REQUIRED	TEST PERFORMED	TEST MODE	RELIEF REQUEST(S)
1-HRV-721	3	3W	4	A	D/8	0	0	3	A	B	EF-1 EF-7 ET-XXX	NOTE 3 EF-8 ET-XXX	P R -	YES, NOTE 3 YES, NOTE 3 YES, NOTE 3
1-HRV-723	3	3W	4	A	B/8	0	0	3	A	B	EF-1 EF-7 ET-XXX	NOTE 3 EF-8 ET-XXX	P R -	YES, NOTE 3 YES, NOTE 3 YES, NOTE 3
1-HRV-725	3	3W	4	A	D/8	0	0	3	A	B	EF-1 EF-7 ET-XXX	NOTE 3 EF-8 ET-XXX	P R -	YES, NOTE 3 YES, NOTE 3 YES, NOTE 3
1-HRV-727	3	3W	4	A	B/8	0	0	3	A	B	EF-1 EF-7 ET-XXX	NOTE 3 EF-8 ET-XXX	P R -	YES, NOTE 3 YES, NOTE 3 YES, NOTE 3

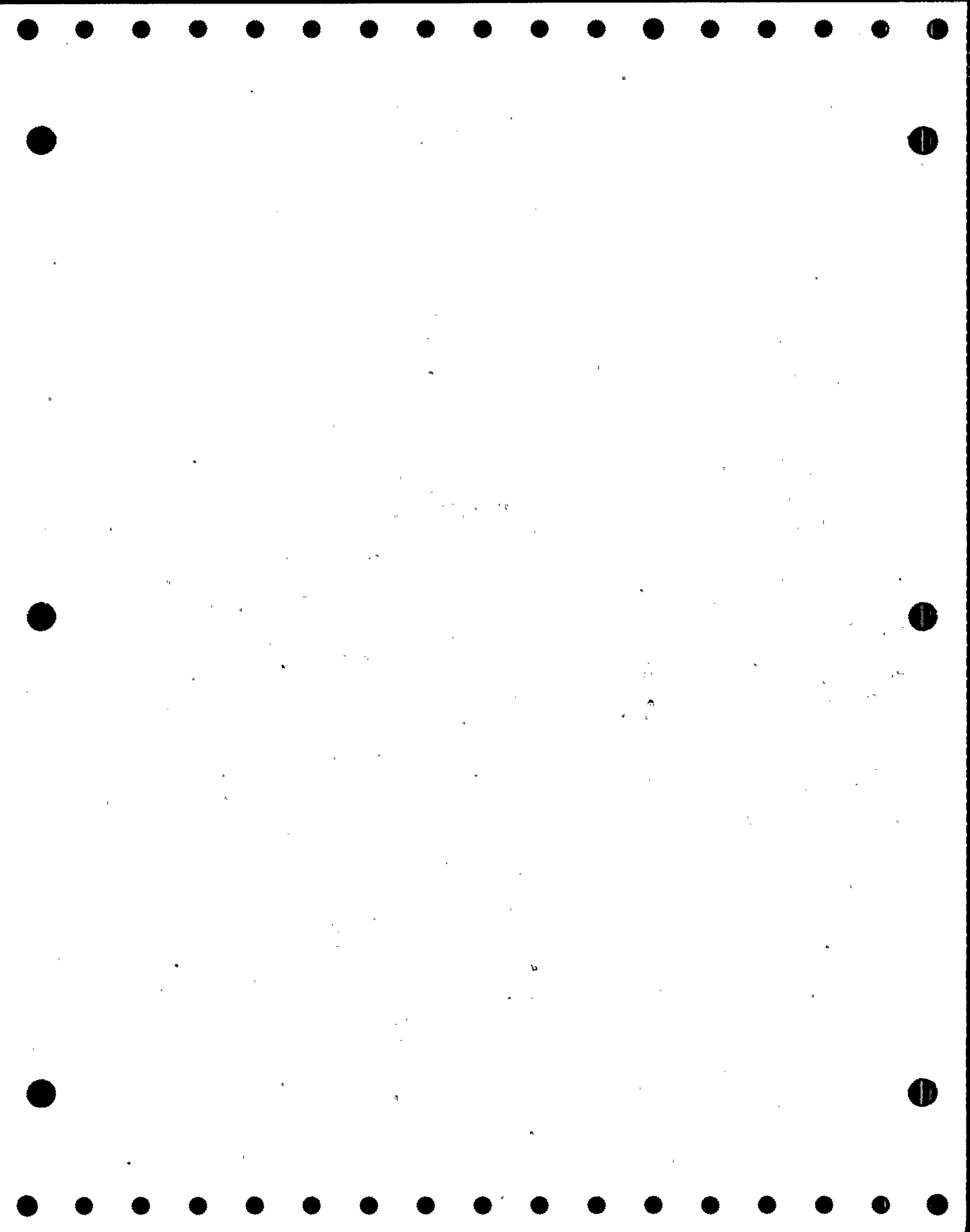

DONALD C. COOK NUCLEAR PLANT
 SECOND TEN YEAR INTERVAL
 VALVE SUMMARY SHEET - UNIT 1
 FLOW DIAGRAM: 1-5114A-31

RUN DATE AND TIME: 15FEB90:16:03

SYSTEM NAME: NON-ESSENTIAL SERVICE WATER

VALVE				VALVE POSITION				ASME SECTION XI						
NUMBER	REV	TYPE	SIZE	ACT TYPE	F.D. COORD	POWER OPER	SAFETY FUNCT	CD ICL	A/P	CAT	PRIM TEST REQUIRED	TEST PERFORMED	TEST MODE	RELIEF REQUEST(S)
1-MCR-900-1	3	DA	6	A	J/9	O	C	2	A	A	EF-1	EF-1	P	NO
											EF-5	EF-5	-	NO
											EF-7	EF-7	P	NO
											ET-XXX	ET-XXX	P	NO
											SLT-1	SLT-2	R	YES, NOTE 1
1-MCR-901-1	3	DA	6	A	K/9	O	C	2	A	A	EF-1	EF-1	P	NO
											EF-5	EF-5	-	NO
											EF-7	EF-7	P	NO
											ET-XXX	ET-XXX	P	NO
											SLT-1	SLT-2	R	YES, NOTE 1
1-MCR-902-1	3	DA	6	A	J/4	O	C	2	A	A	EF-1	EF-1	P	NO
											EF-5	EF-5	-	NO
											EF-7	EF-7	P	NO
											ET-XXX	ET-XXX	P	NO
											SLT-1	SLT-2	R	YES, NOTE 1
1-MCR-903-1	3	DA	6	A	K/4	O	C	2	A	A	EF-1	EF-1	P	NO
											EF-5	EF-5	-	NO
											EF-7	EF-7	P	NO
											ET-XXX	ET-XXX	P	NO
											SLT-1	SLT-2	R	YES, NOTE 1
1-MCR-904-2	3	DA	6	A	J/9	O	C	2	A	A	EF-1	EF-1	P	NO
											EF-5	EF-5	-	NO
											EF-7	EF-7	P	NO
											ET-XXX	ET-XXX	P	NO
											SLT-1	SLT-2	R	YES, NOTE 1

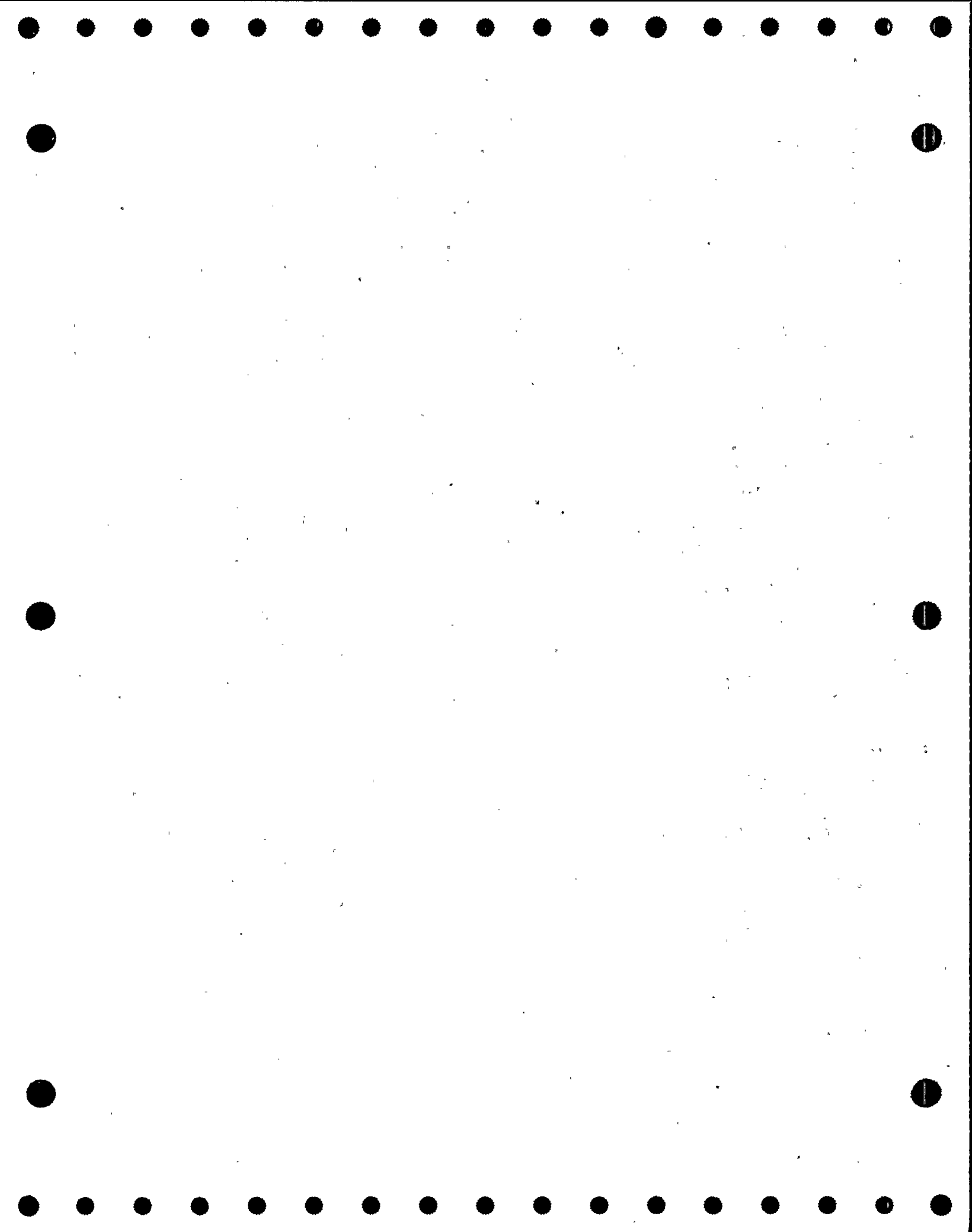

DONALD C. COOK NUCLEAR PLANT
 SECOND TEN YEAR INTERVAL
 VALVE SUMMARY SHEET - UNIT 1
 FLOW DIAGRAM: 1-5114A-31

RUN DATE AND TIME: 15FEB90:16:03

SYSTEM NAME: NON-ESSENTIAL SERVICE WATER

VALVE				VALVE POSITION				ASME SECTION XI						
NUMBER	REV	TYPE	SIZE	ACT TYPE	F.D. COORD	POWER OPER	SAFETY FUNCT	CD ICL	A/P	CAT	PRIM TEST REQUIRED	TEST PERFORMED	TEST MODE	RELIEF REQUEST(S)
1-MCR-905-2	3	DA	6	A	K/9	0	C	2	A	A	EF-1	EF-1	P	NO
											EF-5	EF-5	-	NO
											EF-7	EF-7	P	NO
											ET-XXX	ET-XXX	P	NO
											SLT-1	SLT-2	R	YES, NOTE 1
1-MCR-906-2	3	DA	6	A	J/4	0	C	2	A	A	EF-1	EF-1	P	NO
											EF-5	EF-5	-	NO
											EF-7	EF-7	P	NO
											ET-XXX	ET-XXX	P	NO
											SLT-1	SLT-2	R	YES, NOTE 1
1-MCR-907-2	3	DA	6	A	K/4	0	C	2	A	A	EF-1	EF-1	P	NO
											EF-5	EF-5	-	NO
											EF-7	EF-7	P	NO
											ET-XXX	ET-XXX	P	NO
											SLT-1	SLT-2	R	YES, NOTE 1
1-MCR-908-3	3	DA	6	A	J/9	0	C	2	A	A	EF-1	EF-1	P	NO
											EF-5	EF-5	-	NO
											EF-7	EF-7	P	NO
											ET-XXX	ET-XXX	P	NO
											SLT-1	SLT-2	R	YES, NOTE 1
1-MCR-909-3	3	DA	6	A	K/9	0	C	2	A	A	EF-1	EF-1	P	NO
											EF-5	EF-5	-	NO
											EF-7	EF-7	P	NO
											ET-XXX	ET-XXX	P	NO
											SLT-1	SLT-2	R	YES, NOTE 1

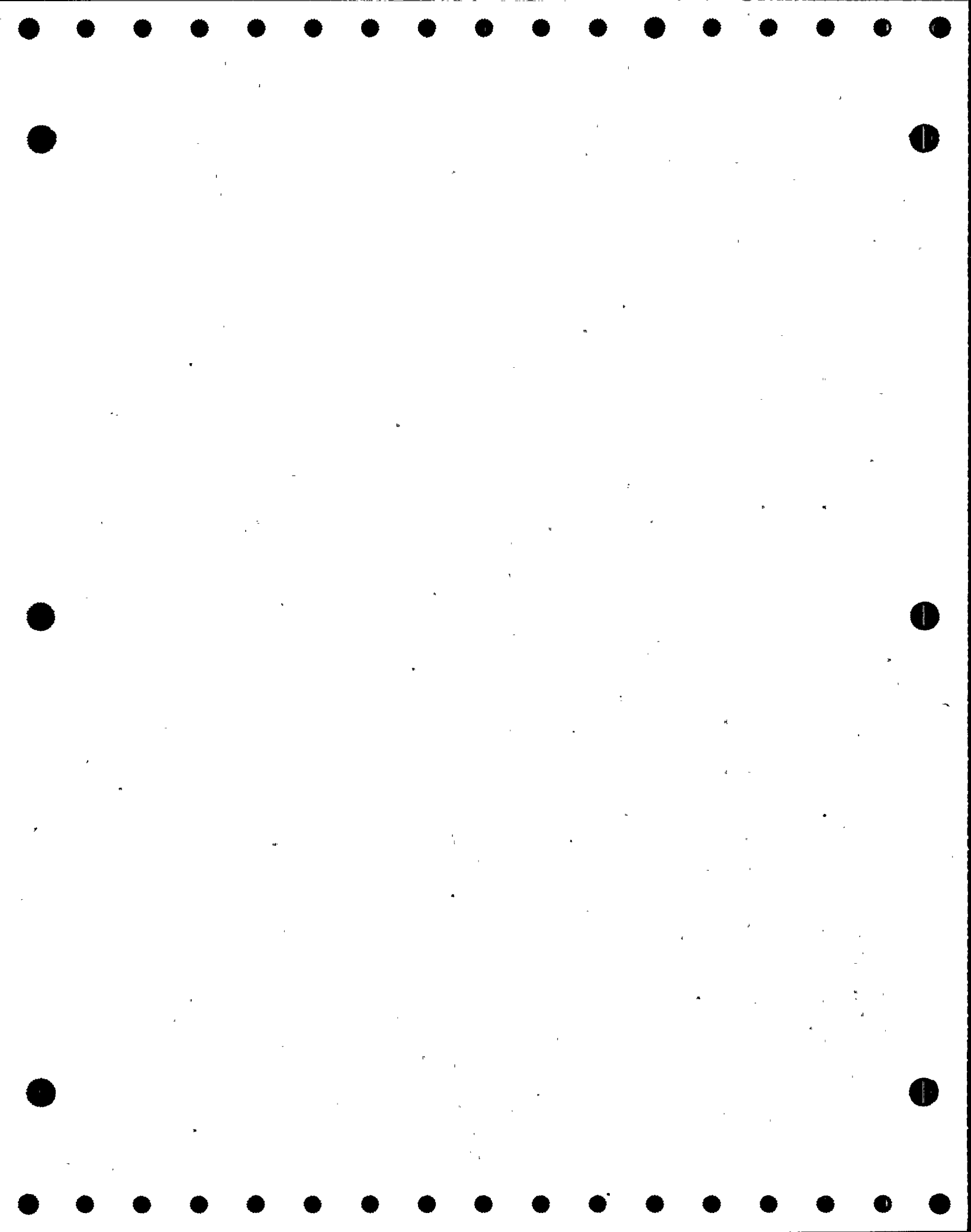

DONALD C. COOK NUCLEAR PLANT
 SECOND TEN YEAR INTERVAL
 VALVE SUMMARY SHEET - UNIT 1
 FLOW DIAGRAM: 1-5114A-31

RUN DATE AND TIME: 15FEB90:16:03

SYSTEM NAME: NON-ESSENTIAL SERVICE WATER

VALVE				VALVE POSITION				ASME SECTION XI						
NUMBER	REV	TYPE	SIZE	ACT TYPE	F.D. COORD	POWER OPER	SAFETY FUNCT	CD ICL	A/P	CAT	PRIM TEST REQUIRED	TEST PERFORMED	TEST MODE	RELIEF REQUEST(S)
1-MCR-910-3	3	DA	6	A	J/4	O	C	2	A	A	EF-1	EF-1	P	NO
											EF-5	EF-5	-	NO
											EF-7	EF-7	P	NO
											ET-XXX	ET-XXX	P	NO
											SLT-1	SLT-2	R	YES, NOTE 1
1-MCR-911-3	3	DA	6	A	K/4	O	C	2	A	A	EF-1	EF-1	P	NO
											EF-5	EF-5	-	NO
											EF-7	EF-7	P	NO
											ET-XXX	ET-XXX	P	NO
											SLT-1	SLT-2	R	YES, NOTE 1
1-MCR-912-4	3	DA	6	A	J/9	O	C	2	A	A	EF-1	EF-1	P	NO
											EF-5	EF-5	-	NO
											EF-7	EF-7	P	NO
											ET-XXX	ET-XXX	P	NO
											SLT-1	SLT-2	R	YES, NOTE 1
1-MCR-913-4	3	DA	6	A	K/9	O	C	2	A	A	EF-1	EF-1	P	NO
											EF-5	EF-5	-	NO
											EF-7	EF-7	P	NO
											ET-XXX	ET-XXX	P	NO
											SLT-1	SLT-2	R	YES, NOTE 1
1-MCR-914-4	3	DA	6	A	J/4	O	C	2	A	A	EF-1	EF-1	P	NO
											EF-5	EF-5	-	NO
											EF-7	EF-7	P	NO
											ET-XXX	ET-XXX	P	NO
											SLT-1	SLT-2	R	YES, NOTE 1

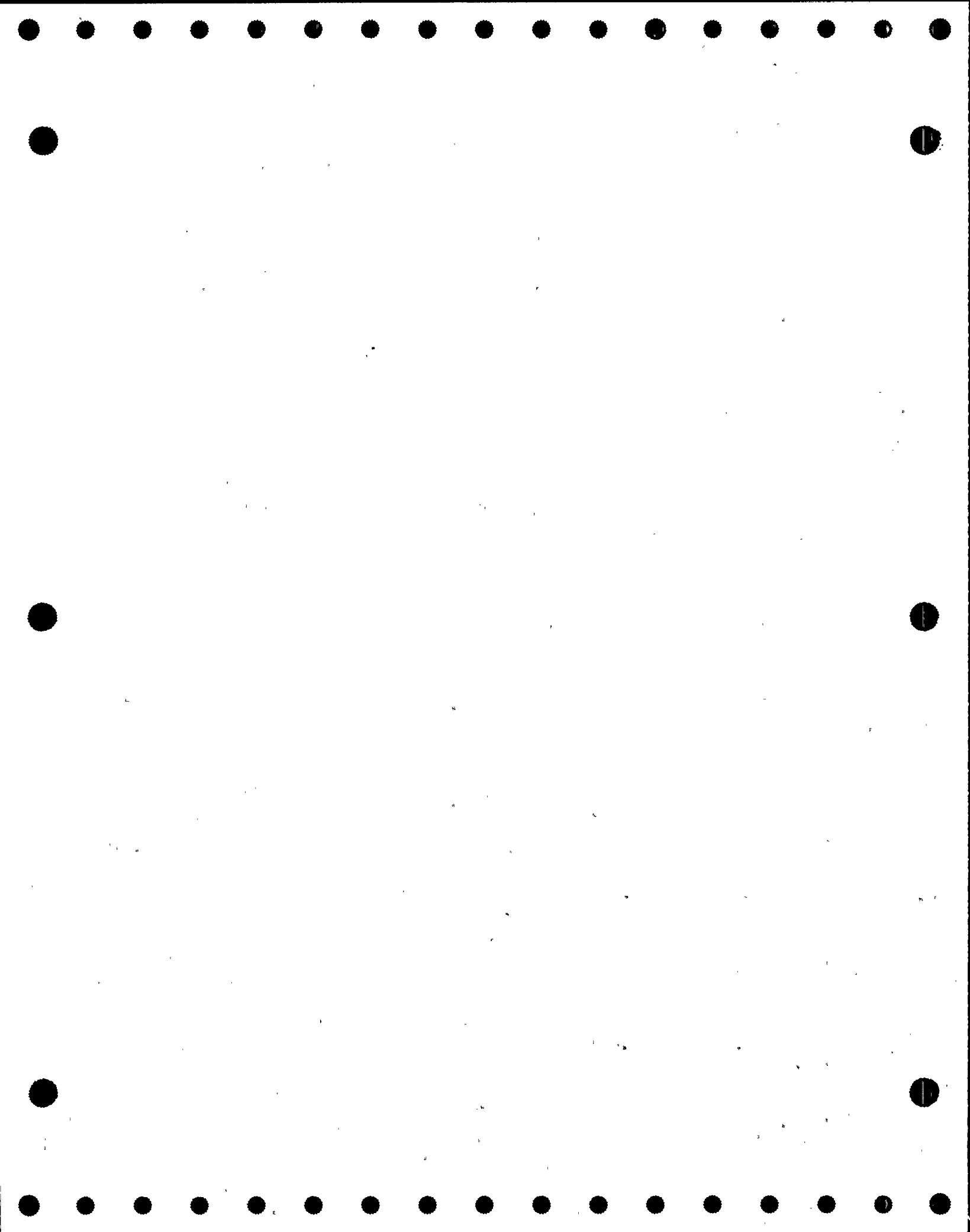

DONALD C. COOK NUCLEAR PLANT
 SECOND TEN YEAR INTERVAL
 VALVE SUMMARY SHEET - UNIT 1
 FLOW DIAGRAM: 1-5114A-31

RUN DATE AND TIME: 15FEB90:16:03

SYSTEM NAME: NON-ESSENTIAL SERVICE WATER

VALVE				VALVE POSITION				ASME SECTION XI					
NUMBER	REV	TYPE	SIZE	ACT TYPE	F.D. COORD	POWER OPER	SAFETY FUNCT	CD A/P CAT	PRIM TEST REQUIRED	TEST PERFORMED	TEST MODE	RELIEF REQUEST(S)	
1-WCR-915-4	3	DA	6	A	K/4	0	C	2 A A	EF-1	EF-1	P	NO	
									EF-5	EF-5	-	NO	
									EF-7	EF-7	P	NO	
									ET-XXX	ET-XXX	P	NO	
									SLT-1	SLT-2	R	YES, NOTE 1	
1-WCR-920-1	3	DA	3	A	J/6	0	C	2 A A	EF-1	EF-1	P	NO	
									EF-5	EF-5	-	NO	
									EF-7	EF-7	P	NO	
									ET-XXX	ET-XXX	P	NO	
									SLT-1	SLT-2	R	YES, NOTE 1	
1-WCR-921-1	3	DA	3	A	K/6	0	C	2 A A	EF-1	EF-1	P	NO	
									EF-5	EF-5	-	NO	
									EF-7	EF-7	P	NO	
									ET-XXX	ET-XXX	P	NO	
									SLT-1	SLT-2	R	YES, NOTE 1	
1-WCR-922-1	3	DA	3	A	K/2	0	C	2 A A	EF-1	EF-1	P	NO	
									EF-5	EF-5	-	NO	
									EF-7	EF-7	P	NO	
									ET-XXX	ET-XXX	P	NO	
									SLT-1	SLT-2	R	YES, NOTE 1	
1-WCR-923-1	3	DA	3	A	J/2	0	C	2 A A	EF-1	EF-1	P	NO	
									EF-5	EF-5	-	NO	
									EF-7	EF-7	P	NO	
									ET-XXX	ET-XXX	P	NO	
									SLT-1	SLT-2	R	YES, NOTE 1	

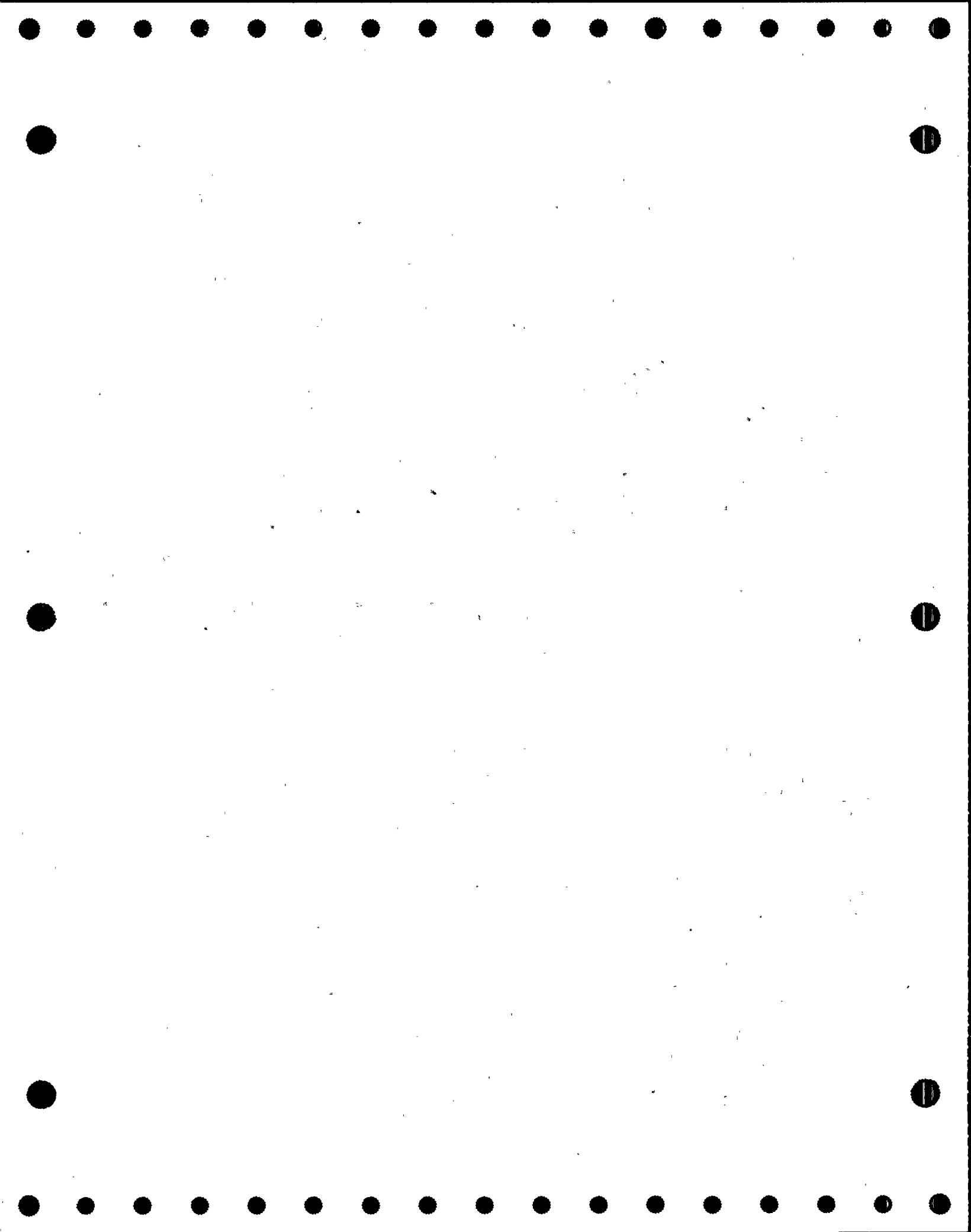

DONALD C. COOK NUCLEAR PLANT
 SECOND TEN YEAR INTERVAL
 VALVE SUMMARY SHEET - UNIT 1
 FLOW DIAGRAM: 1-5114A-31

RUN DATE AND TIME: 15FEB90:16:03

SYSTEM NAME: NON-ESSENTIAL SERVICE WATER

VALVE				VALVE POSITION				ASME SECTION XI						
NUMBER	REV	TYPE	SIZE	ACT TYPE	F.D. COORD	POWER OPER	SAFETY FUNCT	CD ICL	A/P	CAT	PRIM TEST REQUIRED	TEST PERFORMED	TEST MODE	RELIEF REQUEST(S)
1-MCR-924-2	3	DA	3	A	J/6	0	C	2	A	A	EF-1	EF-1	P	NO
											EF-5	EF-5	-	NO
											EF-7	EF-7	P	NO
											ET-XXX	ET-XXX	P	NO
											SLT-1	SLT-2	R	YES, NOTE 1
1-MCR-925-2	3	DA	3	A	K/6	0	C	2	A	A	EF-1	EF-1	P	NO
											EF-5	EF-5	-	NO
											EF-7	EF-7	P	NO
											ET-XXX	ET-XXX	P	NO
											SLT-1	SLT-2	R	YES, NOTE 1
1-MCR-926-2	3	DA	3	A	K/2	0	C	2	A	A	EF-1	EF-1	P	NO
											EF-5	EF-5	-	NO
											EF-7	EF-7	P	NO
											ET-XXX	ET-XXX	P	NO
											SLT-1	SLT-2	R	YES, NOTE 1
1-MCR-927-2	3	DA	3	A	J/2	0	C	2	A	A	EF-1	EF-1	P	NO
											EF-5	EF-5	-	NO
											EF-7	EF-7	P	NO
											ET-XXX	ET-XXX	P	NO
											SLT-1	SLT-2	R	YES, NOTE 1
1-MCR-928-3	3	DA	3	A	J/6	0	C	2	A	A	EF-1	EF-1	P	NO
											EF-5	EF-5	-	NO
											EF-7	EF-7	P	NO
											ET-XXX	ET-XXX	P	NO
											SLT-1	SLT-2	R	YES, NOTE 1

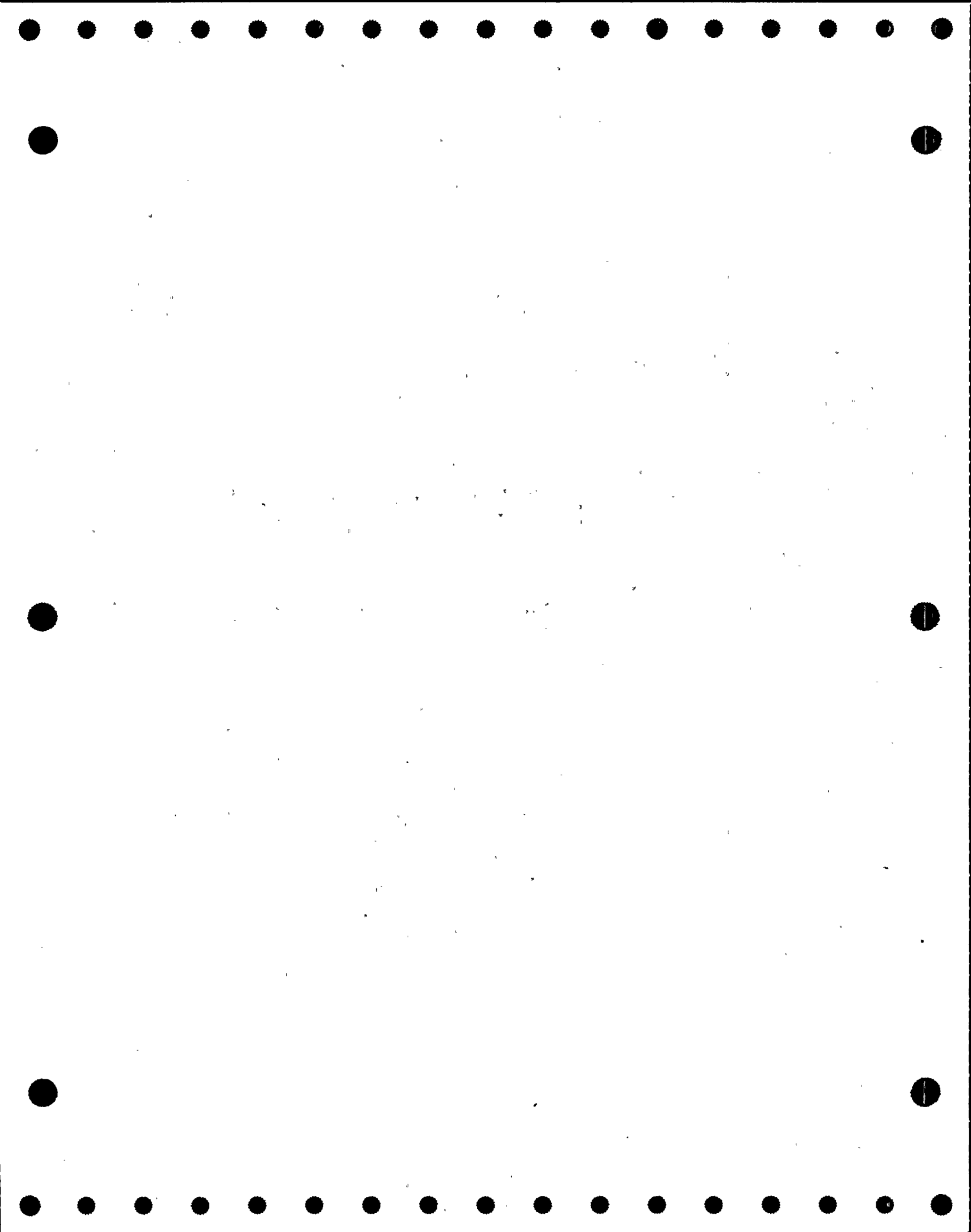

DONALD C. COOK NUCLEAR PLANT
 SECOND TEN YEAR INTERVAL
 VALVE SUMMARY SHEET - UNIT 1
 FLOW DIAGRAM: 1-5114A-31

RUN DATE AND TIME: 15FEB90:16:03

SYSTEM NAME: NON-ESSENTIAL SERVICE WATER

VALVE				VALVE POSITION				ASME SECTION XI						
NUMBER	REV	TYPE	SIZE	ACT TYPE	F.D. COORD	POWER OPER	SAFETY FUNCT	CD ICL	A/P	CAT	PRIM TEST REQUIRED	TEST PERFORMED	TEST MODE	RELIEF REQUEST(S)
1-MCR-929-3	3	DA	3	A	K/6	0	C	2	A	A	EF-1	EF-1	P	NO
											EF-5	EF-5	-	NO
											EF-7	EF-7	P	NO
											ET-XXX	ET-XXX	P	NO
											SLT-1	SLT-2	R	YES, NOTE 1
1-MCR-930-3	3	DA	3	A	K/2	0	C	2	A	A	EF-1	EF-1	P	NO
											EF-5	EF-5	-	NO
											EF-7	EF-7	P	NO
											ET-XXX	ET-XXX	P	NO
											SLT-1	SLT-2	R	YES, NOTE 1
1-MCR-931-3	3	DA	3	A	J/2	0	C	2	A	A	EF-1	EF-1	P	NO
											EF-5	EF-5	-	NO
											EF-7	EF-7	P	NO
											ET-XXX	ET-XXX	P	NO
											SLT-1	SLT-2	R	YES, NOTE 1
1-MCR-932-4	3	DA	3	A	J/6	0	C	2	A	A	EF-1	EF-1	P	NO
											EF-5	EF-5	-	NO
											EF-7	EF-7	P	NO
											ET-XXX	ET-XXX	P	NO
											SLT-1	SLT-2	R	YES, NOTE 1
1-MCR-933-4	3	DA	3	A	K/6	0	C	2	A	A	EF-1	EF-1	P	NO
											EF-5	EF-5	-	NO
											EF-7	EF-7	P	NO
											ET-XXX	ET-XXX	P	NO
											SLT-1	SLT-2	R	YES, NOTE 1

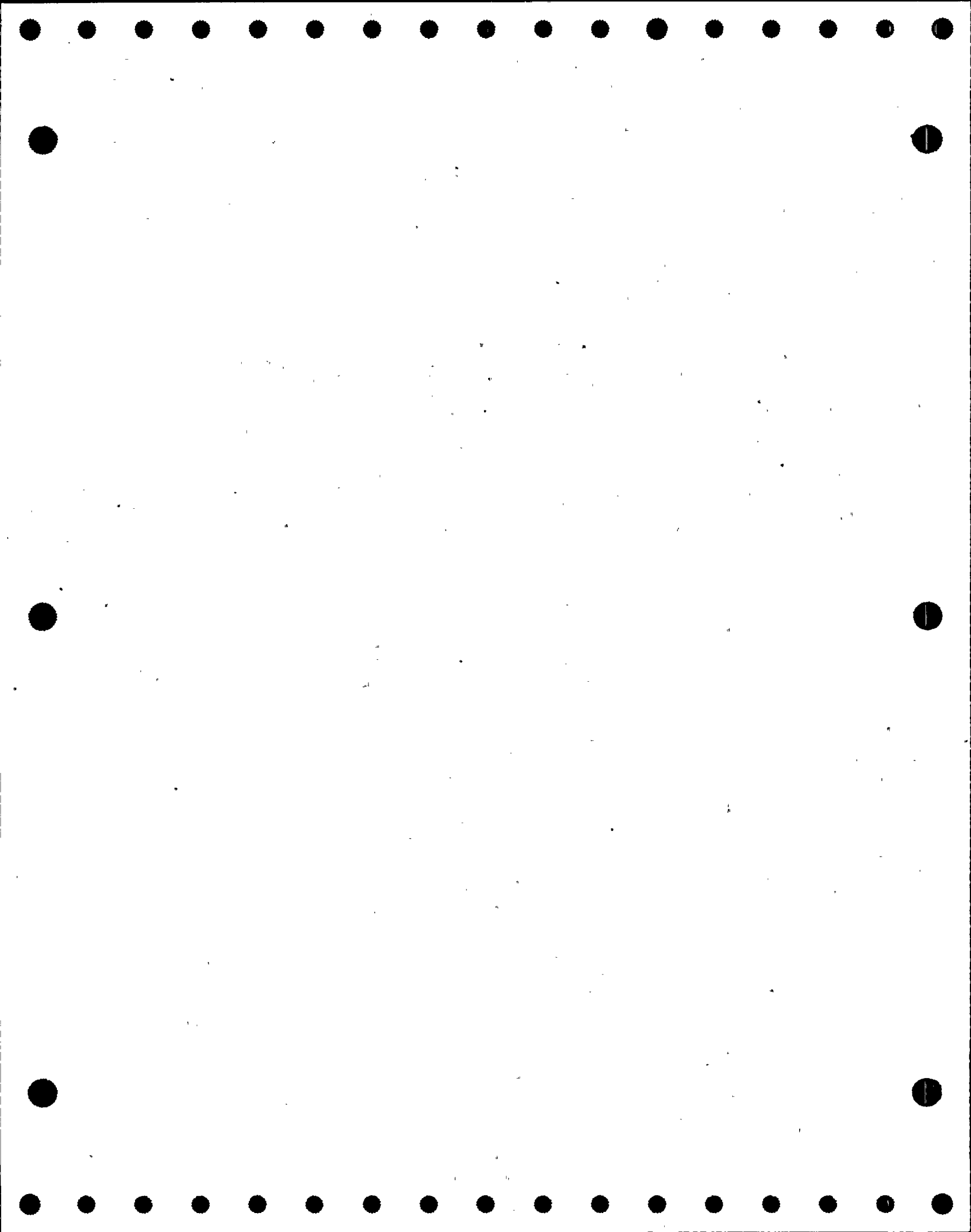

DONALD C. COOK NUCLEAR PLANT
 SECOND TEN YEAR INTERVAL
 VALVE SUMMARY SHEET - UNIT 1
 FLOW DIAGRAM: 1-5114A-31

RUN DATE AND TIME: 15FEB90:16:03

SYSTEM NAME: NON-ESSENTIAL SERVICE WATER

VALVE				VALVE POSITION				ASME SECTION XI						
NUMBER	REV	TYPE	SIZE	ACT TYPE	F.D. COORD	POWER OPER	SAFETY FUNCT	CD ICL	A/P	CAT	PRIM TEST REQUIRED	TEST PERFORMED	TEST MODE	RELIEF REQUEST(S)
1-WCR-934	3	DA	3	A	K/2	0	C	2	A	A	EF-1	EF-1	P	NO
											EF-5	EF-5	-	NO
											EF-7	EF-7	P	NO
											ET-XXX	ET-XXX	P	NO
											SLT-1	SLT-2	R	YES, NOTE 1
1-WCR-935-4	3	DA	3	A	J/2	0	C	2	A	A	EF-1	EF-1	P	NO
											EF-5	EF-5	-	NO
											EF-7	EF-7	P	NO
											ET-XXX	ET-XXX	P	NO
											SLT-1	SLT-2	R	YES, NOTE 1
1-WCR-941-1	3	DA	3	A	J/6	0	C	2	A	A	EF-1	EF-1	P	NO
											EF-5	EF-5	-	NO
											EF-7	EF-7	P	NO
											ET-XXX	ET-XXX	P	NO
											SLT-1	SLT-2	R	YES, NOTE 1
1-WCR-942-2	3	DA	3	A	J/6	0	C	2	A	A	EF-1	EF-1	P	NO
											EF-5	EF-5	-	NO
											EF-7	EF-7	P	NO
											ET-XXX	ET-XXX	P	NO
											SLT-1	SLT-2	R	YES, NOTE 1
1-WCR-943-3	3	DA	3	A	J/6	0	C	2	A	A	EF-1	EF-1	P	NO
											EF-5	EF-5	-	NO
											EF-7	EF-7	P	NO
											ET-XXX	ET-XXX	P	NO
											SLT-1	SLT-2	R	YES, NOTE 1

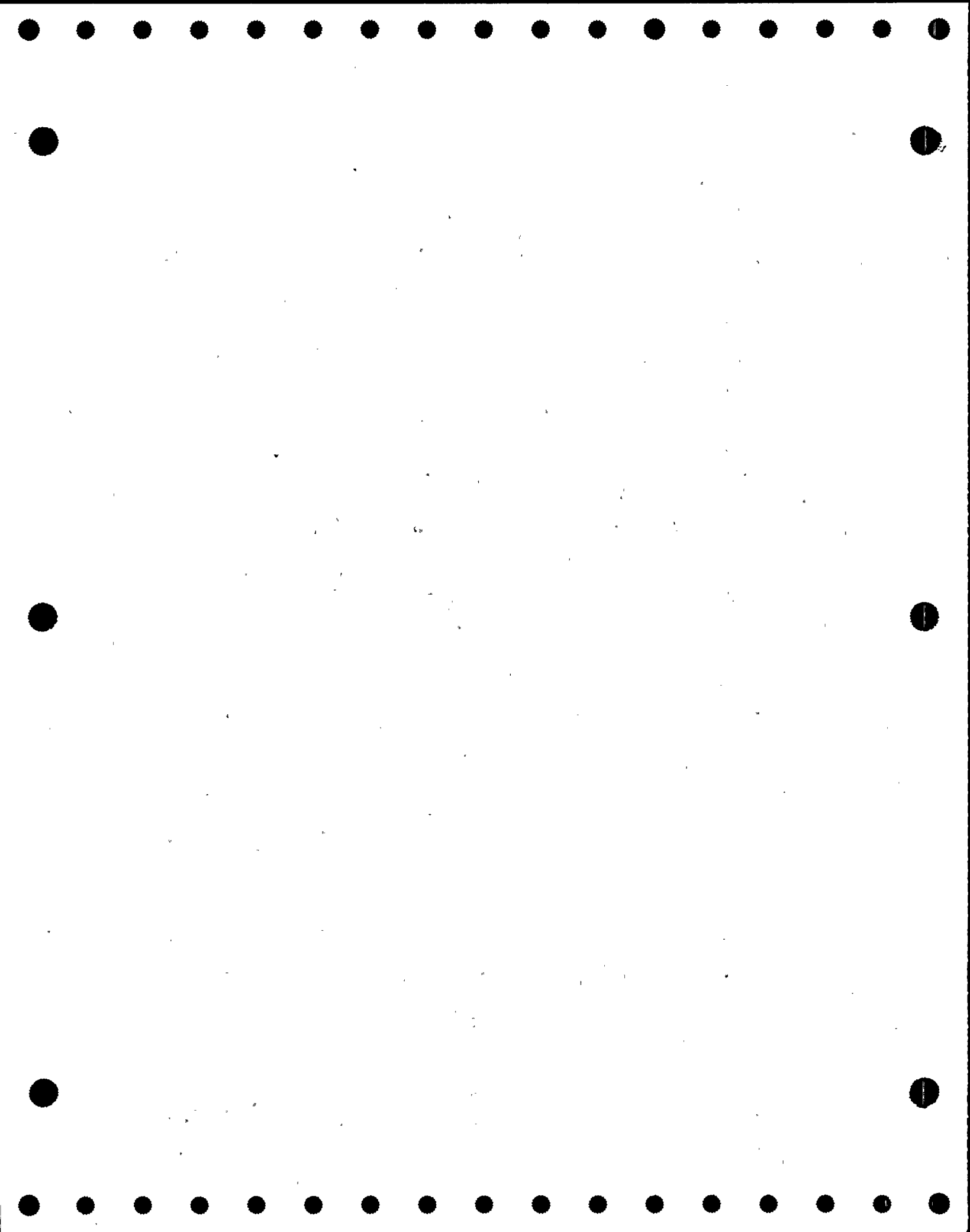

DONALD C. COOK NUCLEAR PLANT
 SECOND TEN YEAR INTERVAL
 VALVE SUMMARY SHEET - UNIT 1
 FLOW DIAGRAM: 1-5114A-31

RUN DATE AND TIME: 15FEB90:16:03

SYSTEM NAME: NON-ESSENTIAL SERVICE WATER

VALVE				VALVE POSITION				ASME SECTION XI						
NUMBER	REV	TYPE	SIZE	ACT TYPE	F.D. COORD	POWER OPER	SAFETY FUNCT	CD ICL	A/P	CAT	PRIM TEST REQUIRED	TEST PERFORMED	TEST MODE	RELIEF REQUEST(S)
1-MCR-944-4	3	DA	3	A	J/6	O	C	2	A	A	EF-1	EF-1	P	NO
											EF-5	EF-5	-	NO
											EF-7	EF-7	P	NO
											ET-XXX	ET-XXX	P	NO
											SLT-1	SLT-2	R	YES, NOTE 1
1-MCR-945-1	3	DA	3	A	J/3	O	C	2	A	A	EF-1	EF-1	P	NO
											EF-5	EF-5	-	NO
											EF-7	EF-7	P	NO
											ET-XXX	ET-XXX	P	NO
											SLT-1	SLT-2	R	YES, NOTE 1
1-MCR-946-2	3	DA	3	A	J/3	O	C	2	A	A	EF-1	EF-1	P	NO
											EF-5	EF-5	-	NO
											EF-7	EF-7	P	NO
											ET-XXX	ET-XXX	P	NO
											SLT-1	SLT-2	R	YES, NOTE 1
1-MCR-947-3	3	DA	3	A	J/3	O	C	2	A	A	EF-1	EF-1	P	NO
											EF-5	EF-5	-	NO
											EF-7	EF-7	P	NO
											ET-XXX	ET-XXX	P	NO
											SLT-1	SLT-2	R	YES, NOTE 1
1-MCR-948-4	3	DA	3	A	J/3	O	C	2	A	A	EF-1	EF-1	P	NO
											EF-5	EF-5	-	NO
											EF-7	EF-7	P	NO
											ET-XXX	ET-XXX	P	NO
											SLT-1	SLT-2	R	YES, NOTE 1

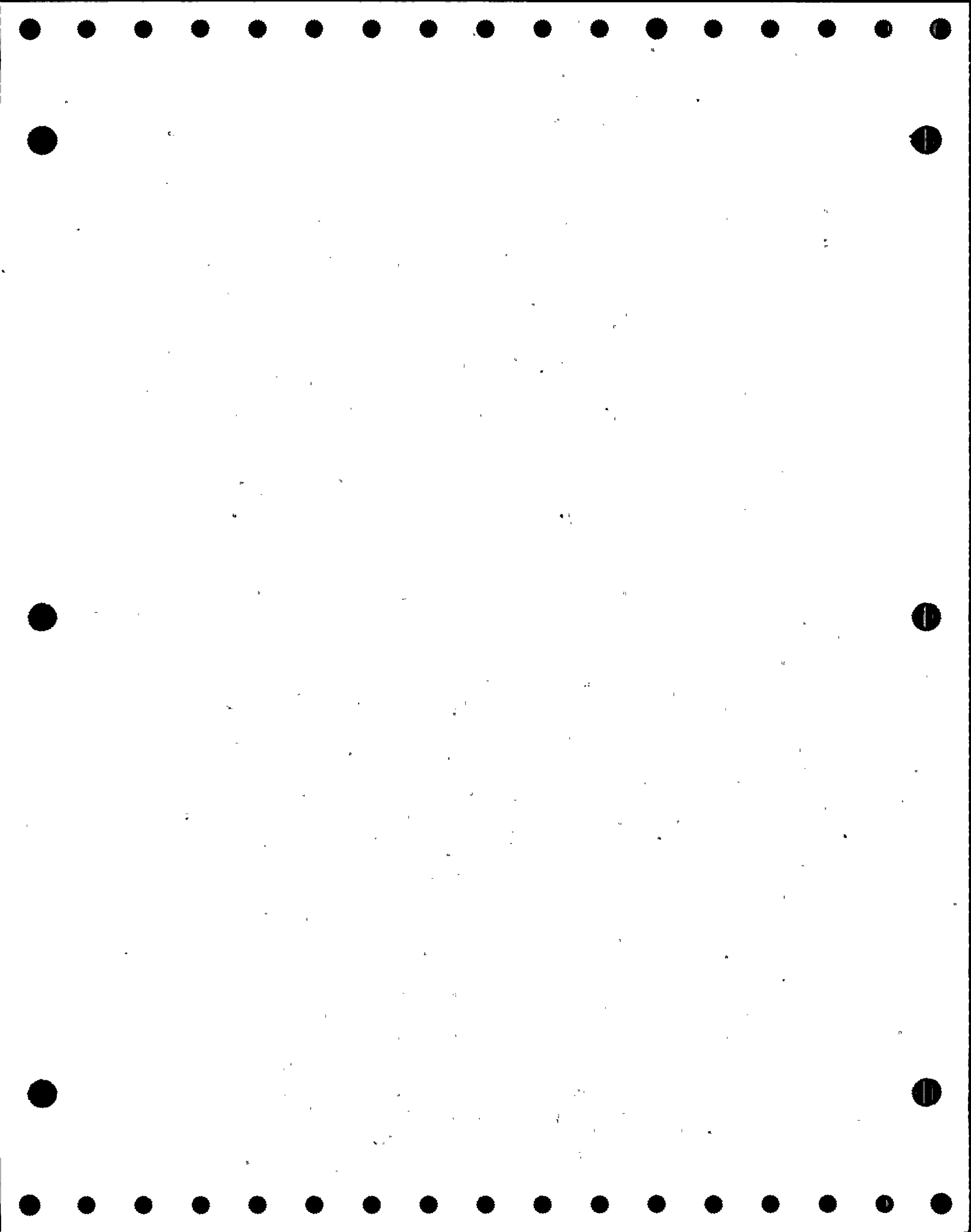

DONALD C. COOK NUCLEAR PLANT
 SECOND TEN YEAR INTERVAL
 VALVE SUMMARY SHEET - UNIT 1
 FLOW DIAGRAM: 1-5114A-31

RUN DATE AND TIME: 15FEB90:16:03

SYSTEM NAME: NON-ESSENTIAL SERVICE WATER

VALVE				VALVE POSITION				ASME SECTION XI						
NUMBER	REV	TYPE	SIZE	ACT TYPE	F.D. COORD	POWER OPER	SAFETY FUNCT	CD [CL	A/P	CAT	PRIM TEST REQUIRED	TEST PERFORMED	TEST MODE	RELIEF REQUEST(S)
1-MCR-951-1	3	DA	3	A	K/6	0	C	2	A	A	EF-1	EF-1	P	NO
											EF-5	EF-5	-	NO
											EF-7	EF-7	P	NO
											ET-XXX	ET-XXX	P	NO
											SLT-1	SLT-2	R	YES, NOTE 1
1-MCR-952-2	3	DA	3	A	K/6	0	C	2	A	A	EF-1	EF-1	P	NO
											EF-5	EF-5	-	NO
											EF-7	EF-7	P	NO
											ET-XXX	ET-XXX	P	NO
											SLT-1	SLT-2	R	YES, NOTE 1
1-MCR-953-3	3	DA	3	A	K/6	0	C	2	A	A	EF-1	EF-1	P	NO
											EF-5	EF-5	-	NO
											EF-7	EF-7	P	NO
											ET-XXX	ET-XXX	P	NO
											SLT-1	SLT-2	R	YES, NOTE 1
1-MCR-954-4	3	DA	3	A	K/6	0	C	2	A	A	EF-1	EF-1	P	NO
											EF-5	EF-5	-	NO
											EF-7	EF-7	P	NO
											ET-XXX	ET-XXX	P	NO
											SLT-1	SLT-2	R	YES, NOTE 1
1-MCR-955-1	3	DA	3	A	J/3	0	C	2	A	A	EF-1	EF-1	P	NO
											EF-5	EF-5	-	NO
											EF-7	EF-7	P	NO
											ET-XXX	ET-XXX	P	NO
											SLT-1	SLT-2	R	YES, NOTE 1

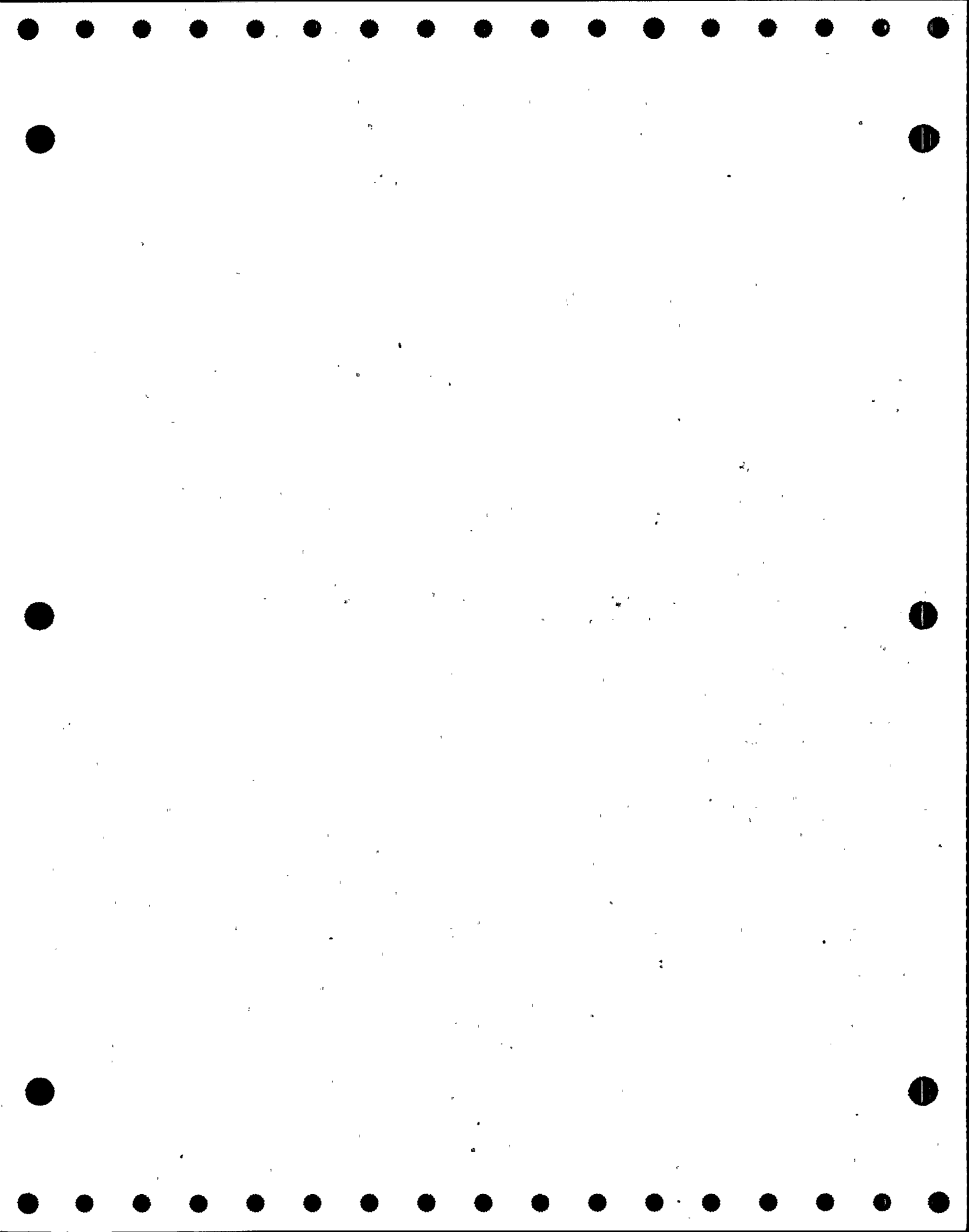

DONALD C. COOK NUCLEAR PLANT
 SECOND TEN YEAR INTERVAL
 VALVE SUMMARY SHEET - UNIT 1
 FLOW DIAGRAM: 1-5114A-31

RUN DATE AND TIME: 15FEB90:16:03

SYSTEM NAME: NON-ESSENTIAL SERVICE WATER

VALVE				VALVE POSITION				ASME SECTION XI						
NUMBER	REV	TYPE	SIZE	ACT TYPE	F.D. COORD	POWER OPER	SAFETY FUNCT	CD ICL	A/P	CAT	PRIM TEST REQUIRED	TEST PERFORMED	TEST MODE	RELIEF REQUEST(S)
1-MCR-956-2	3	DA	3	A	J/3	0	C	2	A	A	EF-1	EF-1	P	NO
											EF-5	EF-5	-	NO
											EF-7	EF-7	P	NO
											ET-XXX	ET-XXX	P	NO
											SLT-1	SLT-2	R	YES, NOTE 1
1-MCR-957-3	3	DA	3	A	J/3	0	C	2	A	A	EF-1	EF-1	P	NO
											EF-5	EF-5	-	NO
											EF-7	EF-7	P	NO
											ET-XXX	ET-XXX	P	NO
											SLT-1	SLT-2	R	YES, NOTE 1
1-MCR-958-4	3	DA	3	A	J/3	0	C	2	A	A	EF-1	EF-1	P	NO
											EF-5	EF-5	-	NO
											EF-7	EF-7	P	NO
											ET-XXX	ET-XXX	P	NO
											SLT-1	SLT-2	R	YES, NOTE 1
1-MCR-960-4	3	DA	2	A	J/7	0	C	2	A	A	EF-1	EF-1	P	NO
											EF-5	EF-5	-	NO
											EF-7	EF-7	P	NO
											ET-XXX	ET-XXX	P	NO
											SLT-1	SLT-2	R	YES, NOTE 1
1-MCR-961-4	3	DA	2	A	J/7	0	C	2	A	A	EF-1	EF-1	P	NO
											EF-5	EF-5	-	NO
											EF-7	EF-7	P	NO
											ET-XXX	ET-XXX	P	NO
											SLT-1	SLT-2	R	YES, NOTE 1

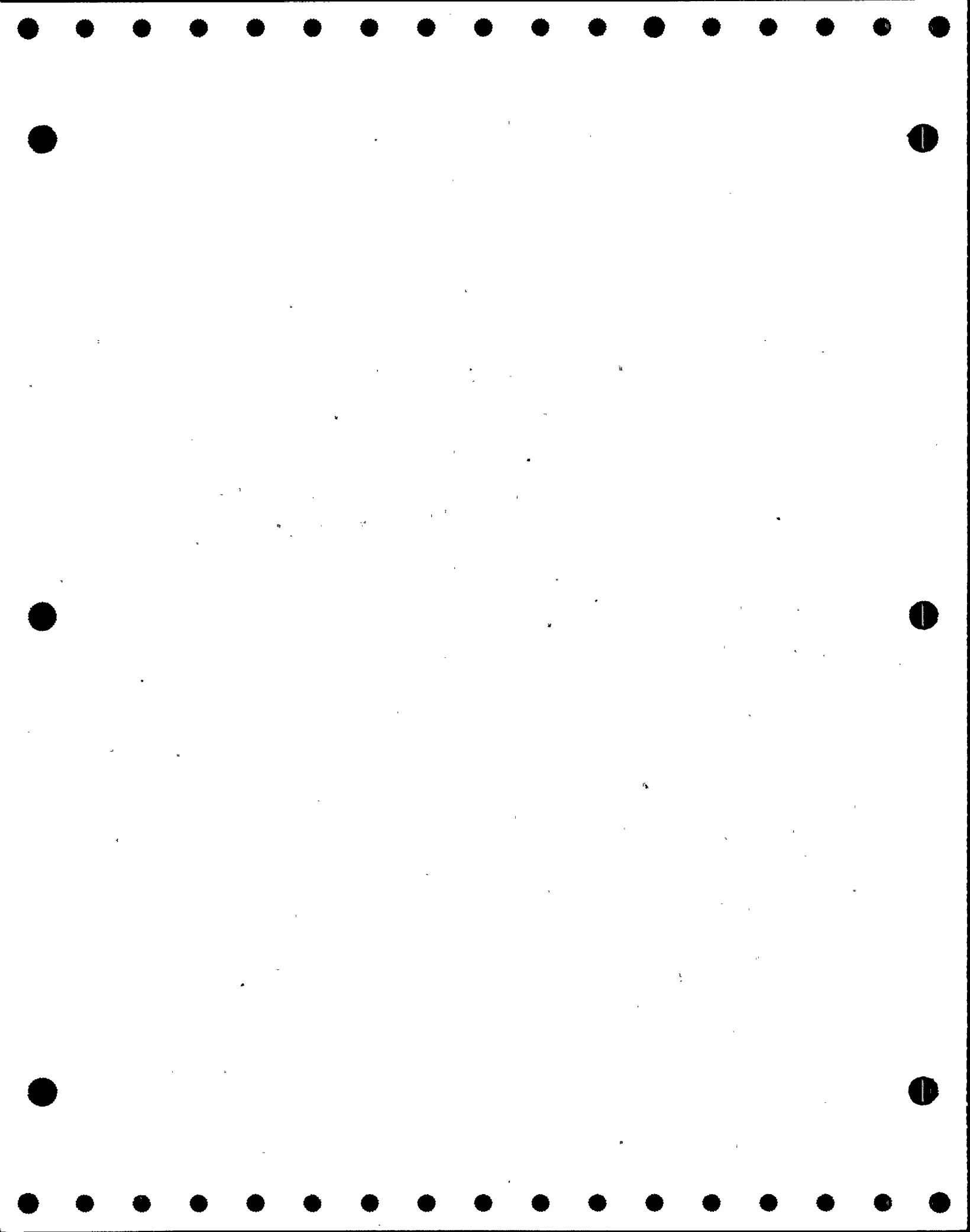

DONALD C. COOK NUCLEAR PLANT
 SECOND TEN YEAR INTERVAL
 VALVE SUMMARY SHEET - UNIT 1
 FLOW DIAGRAM: 1-5114A-31

RUN DATE AND TIME: 15FEB90:16:03

SYSTEM NAME: NON-ESSENTIAL SERVICE WATER

VALVE				VALVE POSITION				ASME SECTION XI						
NUMBER	REV	TYPE	SIZE	ACT TYPE	F.D. COORD	POWER OPER	SAFETY FUNCT	CD ICL	A/P	CAT	PRIM TEST REQUIRED	TEST PERFORMED	TEST MODE	RELIEF REQUEST(S)
1-MCR-962-4	3	DA	2	A	J/3	0	C	2	A	A	EF-1	EF-1	P	NO
											EF-5	EF-5	-	NO
											EF-7	EF-7	P	NO
											ET-XXX	ET-XXX	P	NO
											SLT-1	SLT-2	R	YES, NOTE 1
1-MCR-963-4	3	DA	2	A	J/3	0	C	2	A	A	EF-1	EF-1	P	NO
											EF-5	EF-5	-	NO
											EF-7	EF-7	P	NO
											ET-XXX	ET-XXX	P	NO
											SLT-1	SLT-2	R	YES, NOTE 1
1-MCR-964-3	3	DA	2	A	J/7	0	C	2	A	A	EF-1	EF-1	P	NO
											EF-5	EF-5	-	NO
											EF-7	EF-7	P	NO
											ET-XXX	ET-XXX	P	NO
											SLT-1	SLT-2	R	YES, NOTE 1
1-MCR-965-3	3	DA	2	A	J/7	0	C	2	A	A	EF-1	EF-1	P	NO
											EF-5	EF-5	-	NO
											EF-7	EF-7	P	NO
											ET-XXX	ET-XXX	P	NO
											SLT-1	SLT-2	R	YES, NOTE 1
1-MCR-966-3	3	DA	2	A	J/3	0	C	2	A	A	EF-1	EF-1	P	NO
											EF-5	EF-5	-	NO
											EF-7	EF-7	P	NO
											ET-XXX	ET-XXX	P	NO
											SLT-1	SLT-2	R	YES, NOTE 1

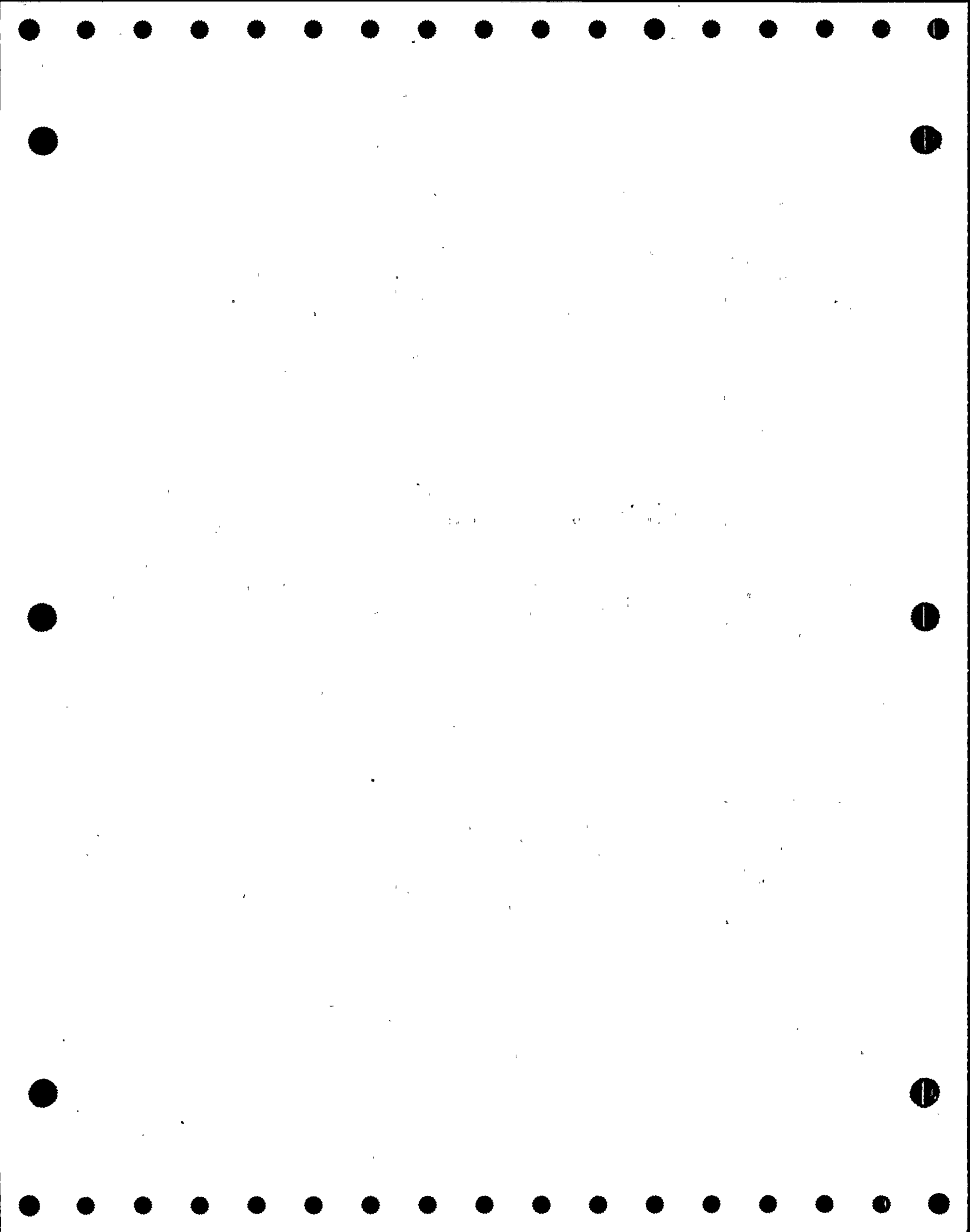

DONALD C. COOK NUCLEAR PLANT
 SECOND TEN YEAR INTERVAL
 VALVE SUMMARY SHEET - UNIT 1
 FLOW DIAGRAM: 1-5114A-31

RUN DATE AND TIME: 15FEB90:16:03

SYSTEM NAME: NON-ESSENTIAL SERVICE WATER

VALVE				VALVE POSITION				ASME SECTION XI						
NUMBER	REV	TYPE	SIZE	ACT TYPE	F.D. COORD	POWER OPER	SAFETY FUNCT	CD ICL	A/P	CAT	PRIM TEST REQUIRED	TEST PERFORMED	TEST MODE	RELIEF REQUEST(S)
1-WCR-967-3	3	DA	2	A	J/3	0	C	2	A	A	EF-1 EF-5 EF-7 ET-XXX SLT-1	EF-1 EF-5 EF-7 ET-XXX SLT-2	P - P P R	NO NO NO NO YES, NOTE 1

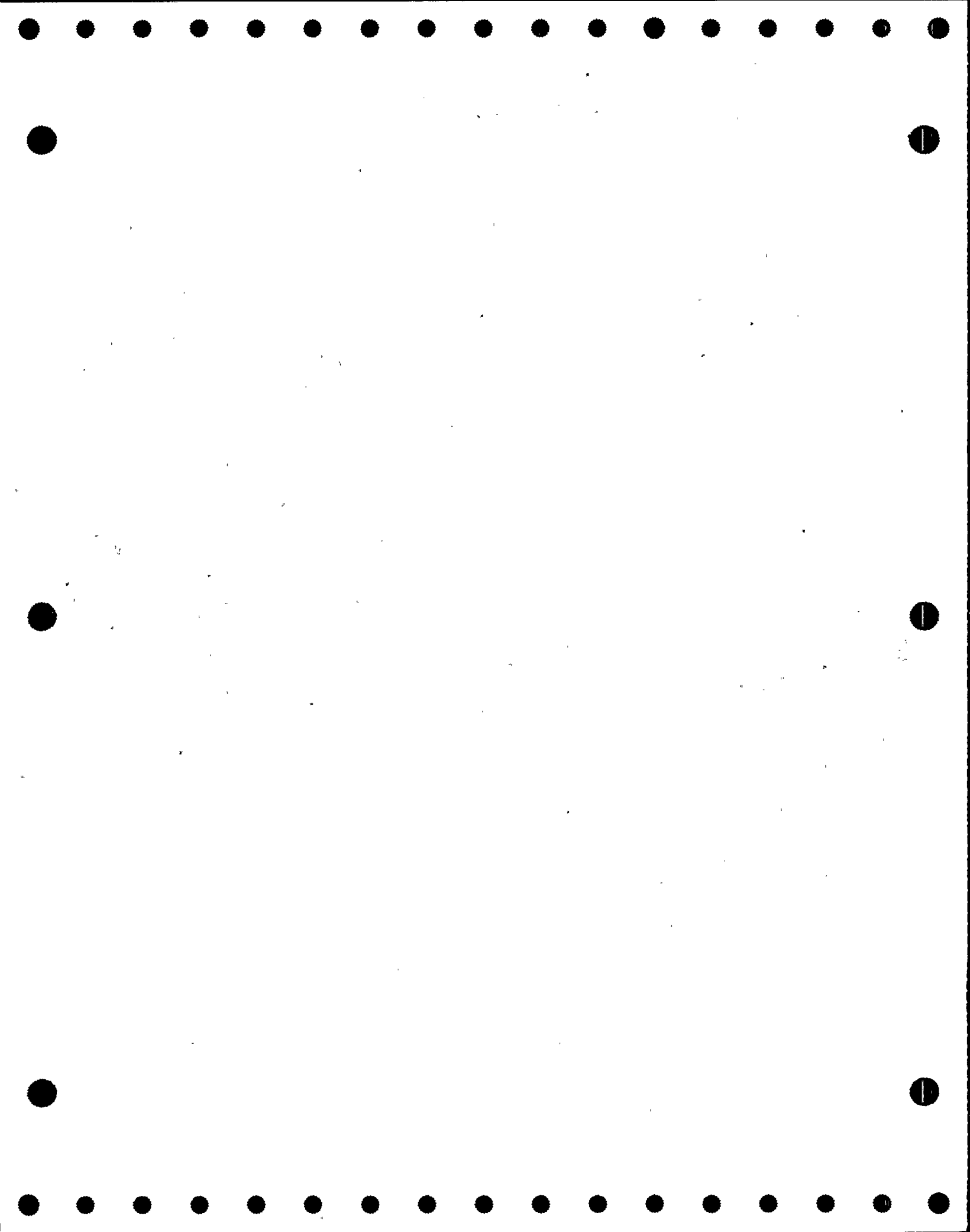

DONALD C. COOK NUCLEAR PLANT
 SECOND TEN YEAR INTERVAL
 VALVE SUMMARY SHEET - UNIT 1
 FLOW DIAGRAM: 1-5124-22

RUN DATE AND TIME: 15FEB90:16:03

SYSTEM NAME: STATION DRAINAGE - CONTAINMENT

VALVE				VALVE POSITION				ASME SECTION XI						
NUMBER	REV	TYPE	SIZE	ACT TYPE	F.D. COORD	POWER OPER	SAFETY FUNCT	CD ICL	A/P	CAT	PRIM TEST REQUIRED	TEST PERFORMED	TEST MODE	RELIEF REQUEST(S)
1-DCR-600	3	DA	3	A	N/6	O	C	2	A	A	EF-1	EF-1	P	NO
											EF-5	EF-5	-	NO
											EF-7	EF-7	P	NO
											ET-XXX	ET-XXX	P	NO
											SLT-1	SLT-2	R	YES, NOTE 1
1-DCR-601	3	DA	3	A	N/6	O	C	2	A	A	EF-1	EF-1	P	NO
											EF-5	EF-5	-	NO
											EF-7	EF-7	P	NO
											ET-XXX	ET-XXX	P	NO
											SLT-1	SLT-2	R	YES, NOTE 1
1-NS-357	3	CK	0.5	SA	K/9	C	O/C	2	A	AC	CF-1	CF-2	R	YES, NOTE 2
											SLT-1	SLT-2	R	YES, NOTE 1

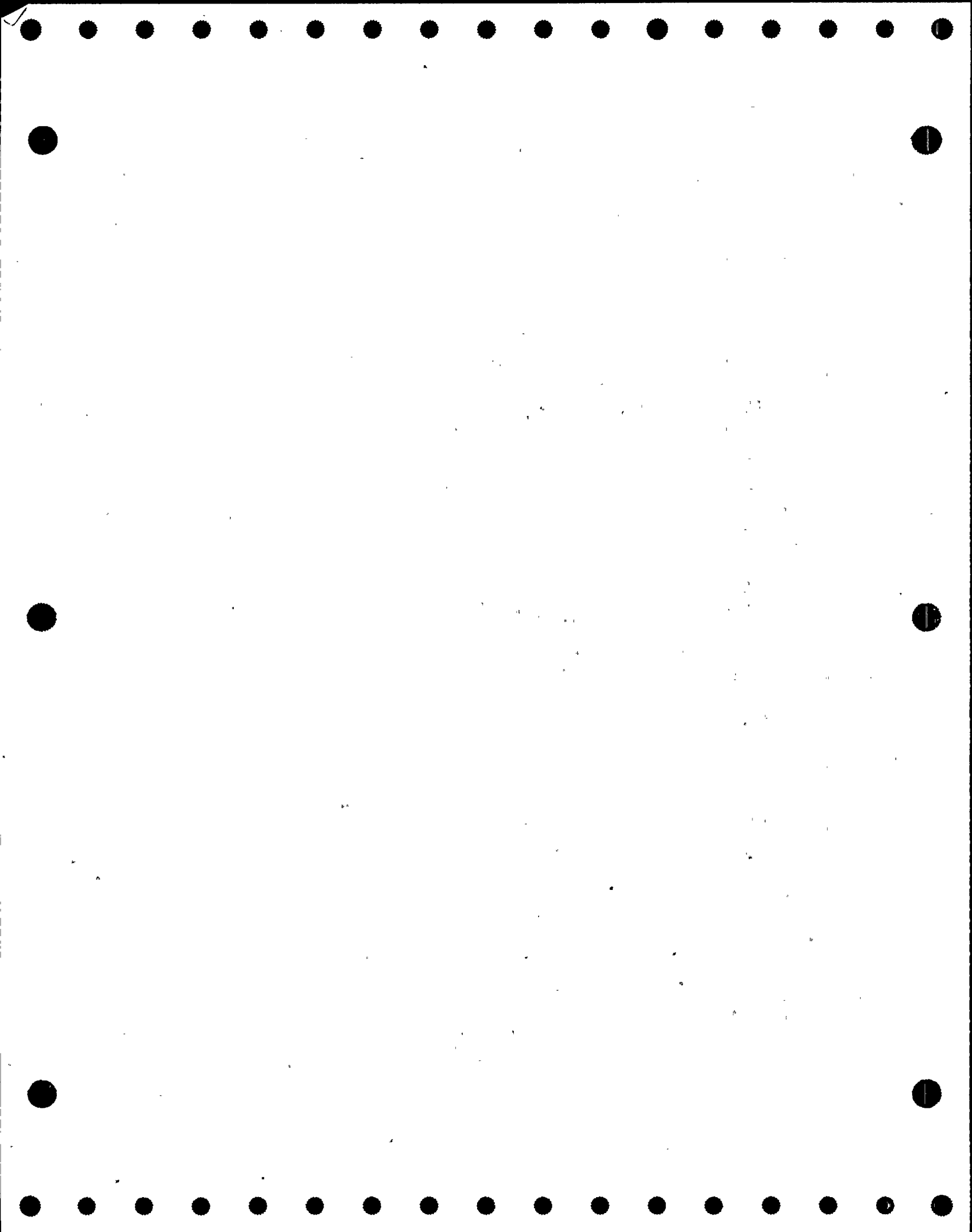

DONALD C. COOK NUCLEAR PLANT
 SECOND TEN YEAR INTERVAL
 VALVE SUMMARY SHEET - UNIT 1
 FLOW DIAGRAM: 1-5128-19

RUN DATE AND TIME: 15FEB90:16:03

SYSTEM NAME: REACTOR COOLANT

VALVE				VALVE POSITION				ASME SECTION XI						
NUMBER	REV	TYPE	SIZE	ACT TYPE	F.D. COORD	POWER OPER	SAFETY FUNCT	CD ICL	A/P	CAT	PRIM TEST REQUIRED	TEST PERFORMED	TEST MODE	RELIEF REQUEST(S)
1-NS0-021	3	GL	1	SO	E/6	C	O/C	2	A	B	EF-1	EF-2	C	NO, CSJ 1
											EF-5	EF-5	-	NO, CSJ 1
											EF-7	EF-8	C	NO, CSJ 1
											ET-XXX	ET-XXX	C	NO, CSJ 1
1-NS0-022	3	GL	1	SO	E/6	C	O/C	2	A	B	EF-1	EF-2	C	NO, CSJ 1
											EF-5	EF-5	-	NO, CSJ 1
											EF-7	EF-8	C	NO, CSJ 1
											ET-XXX	ET-XXX	C	NO, CSJ 1
1-NS0-023	3	GL	1	SO	E/6	C	O/C	2	A	B	EF-1	EF-2	C	NO, CSJ 1
											EF-5	EF-5	-	NO, CSJ 1
											EF-7	EF-8	C	NO, CSJ 1
											ET-XXX	ET-XXX	C	NO, CSJ 1
1-NS0-024	3	GL	1	SO	E/6	C	O/C	2	A	B	EF-1	EF-2	C	NO, CSJ 1
											EF-5	EF-5	-	NO, CSJ 1
											EF-7	EF-8	C	NO, CSJ 1
											ET-XXX	ET-XXX	C	NO, CSJ 1

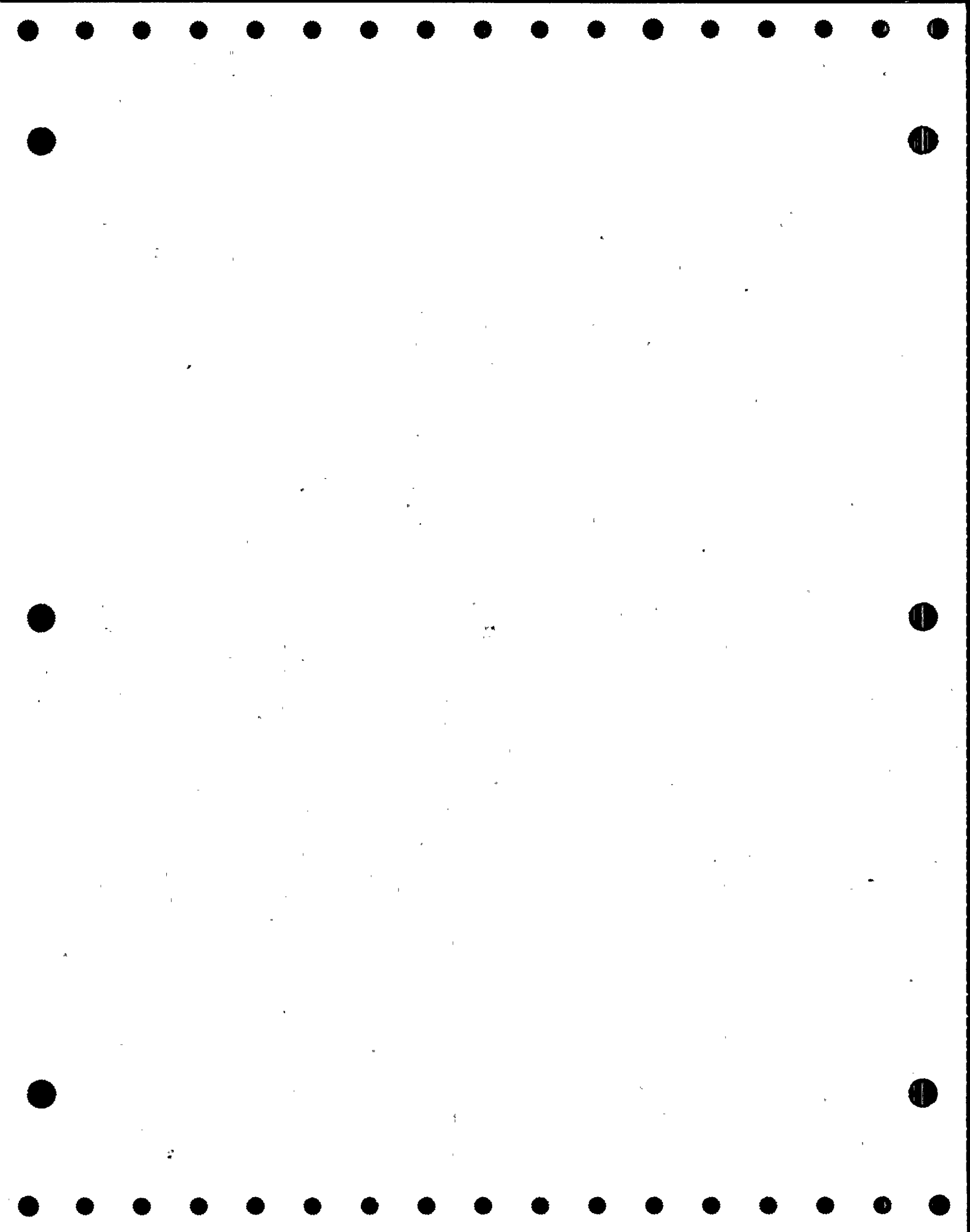

DONALD C. COOK NUCLEAR PLANT
 SECOND TEN YEAR INTERVAL
 VALVE SUMMARY SHEET - UNIT 1
 FLOW DIAGRAM: 1-5128A-37

RUN DATE AND TIME: 15FEB90:16:03

SYSTEM NAME: REACTOR COOLANT

VALVE				VALVE POSITION				ASME SECTION XI						
NUMBER	REV	TYPE	SIZE	ACT TYPE	F.D. COORD	POWER OPER	SAFETY FUNCT	CD ICL	A/P	CAT	PRIM TEST REQUIRED	TEST PERFORMED	TEST MODE	RELIEF REQUEST(S)
1-CS-442-1	3	CK	2	SA	B/4	O	C	2	A	AC	CF-1 SLT-1	CF-2 SLT-2	R R	YES, NOTE 1 YES, NOTE 2
1-CS-442-2	3	CK	2	SA	B/4	O	C	2	A	AC	CF-1 SLT-1	CF-2 SLT-2	R R	YES, NOTE 1 YES, NOTE 2
1-CS-442-3	3	CK	2	SA	B/4	O	C	2	A	AC	CF-1 SLT-1	CF-2 SLT-2	R R	YES, NOTE 1 YES, NOTE 2
1-CS-442-4	3	CK	2	SA	B/4	O	C	2	A	AC	CF-1 SLT-1	CF-2 SLT-2	R R	YES, NOTE 1 YES, NOTE 2
1-GCR-301	3	DA	0.75	A	B/8	O	C	2	A	A	EF-1 EF-5 EF-7 ET-XXX SLT-1	EF-1 EF-5 EF-7 ET-XXX SLT-2	P - P P R	NO NO NO NO YES, NOTE 2
1-N-159	3	CK	0.75	SA	C/8	O/C	C	2	A	AC	CF-1 SLT-1	CF-2 SLT-2	R R	YES, NOTE 5 YES, NOTE 2
1-NCR-252	3	GL	3	A	B/9	C	C	2	P	A	EF-1 EF-5 EF-7 ET-XXX SLT-1	EF-1 EF-5 EF-7 ET-XXX SLT-2	P - P P R	NO NO NO NO YES, NOTE 2
1-NMO-151	3	GA	3	MO	K/7	O	C	1	A	B	EF-1 EF-5 ET-XXX	EF-1 EF-5 ET-XXX	P - P	NO NO NO

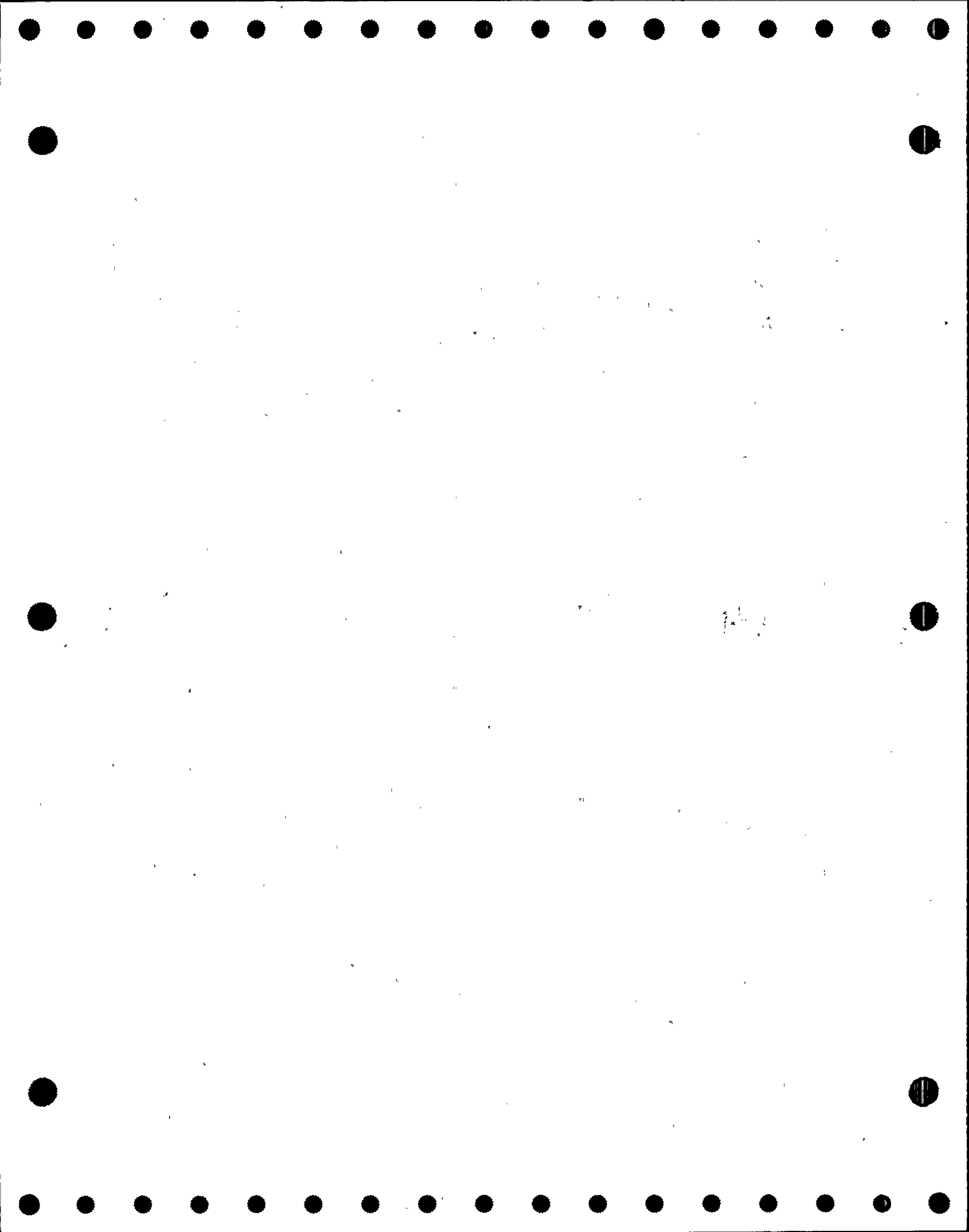

DONALD C. COOK NUCLEAR PLANT
 SECOND TEN YEAR INTERVAL
 VALVE SUMMARY SHEET - UNIT 1
 FLOW DIAGRAM: 1-5128A-37

RUN DATE AND TIME: 15FEB90:16:03

SYSTEM NAME: REACTOR COOLANT

VALVE				VALVE POSITION				ASME SECTION XI						
NUMBER	REV	TYPE	SIZE	ACT TYPE	F.D. COORD	POWER OPER	SAFETY FUNCT	CD ICL	A/P	CAT	PRIM TEST REQUIRED	TEST PERFORMED	TEST MODE	RELIEF REQUEST(S)
1-NMO-152	3	GA	3	MO	K/7	O	C	1	A	B	EF-1 EF-5 ET-XXX	EF-1 EF-5 ET-XXX	P - P	NO NO NO
1-NMO-153	3	GA	3	MO	K/6	O	C	1	A	B	EF-1 EF-5 ET-XXX	EF-1 EF-5 ET-XXX	P - P	NO NO NO
1-NPX-151	3	GL	0.5	M	N/8	C	C	2	P	A	SLT-1	SLT-2	R	YES, NOTE 2
1-NRV-151	3	GL	3	A	K/7	C	C/O	1	A	B	EF-1 EF-5 EF-7 ET-XXX	EF-2 EF-5 EF-8 ET-XXX	- - - -	NO, CSJ 3 NO NO, CSJ 3 NO, CSJ 3
1-NRV-152	3	GL	3	A	K/7	C	C/O	1	A	B	EF-1 EF-5 EF-7 ET-XXX	EF-2 EF-5 EF-8 ET-XXX	- - - -	NO, CSJ 3 NO NO, CSJ 3 NO, CSJ 3
1-NRV-153	3	GL	3	A	K/6	C	C/O	1	A	B	EF-1 EF-5 EF-7 ET-XXX	EF-2 EF-5 EF-8 ET-XXX	- - - -	NO, CSJ 3 NO NO, CSJ 3 NO, CSJ 3
1-NSO-061	3	GL	1	SO	M/6	C	O/C	2	A	B	EF-1 EF-5 EF-7 ET-XXX	EF-2 EF-5 EF-8 ET-XXX	C - C C	NO, CSJ 6 NO, CSJ 6 NO, CSJ 6 NO, CSJ 6

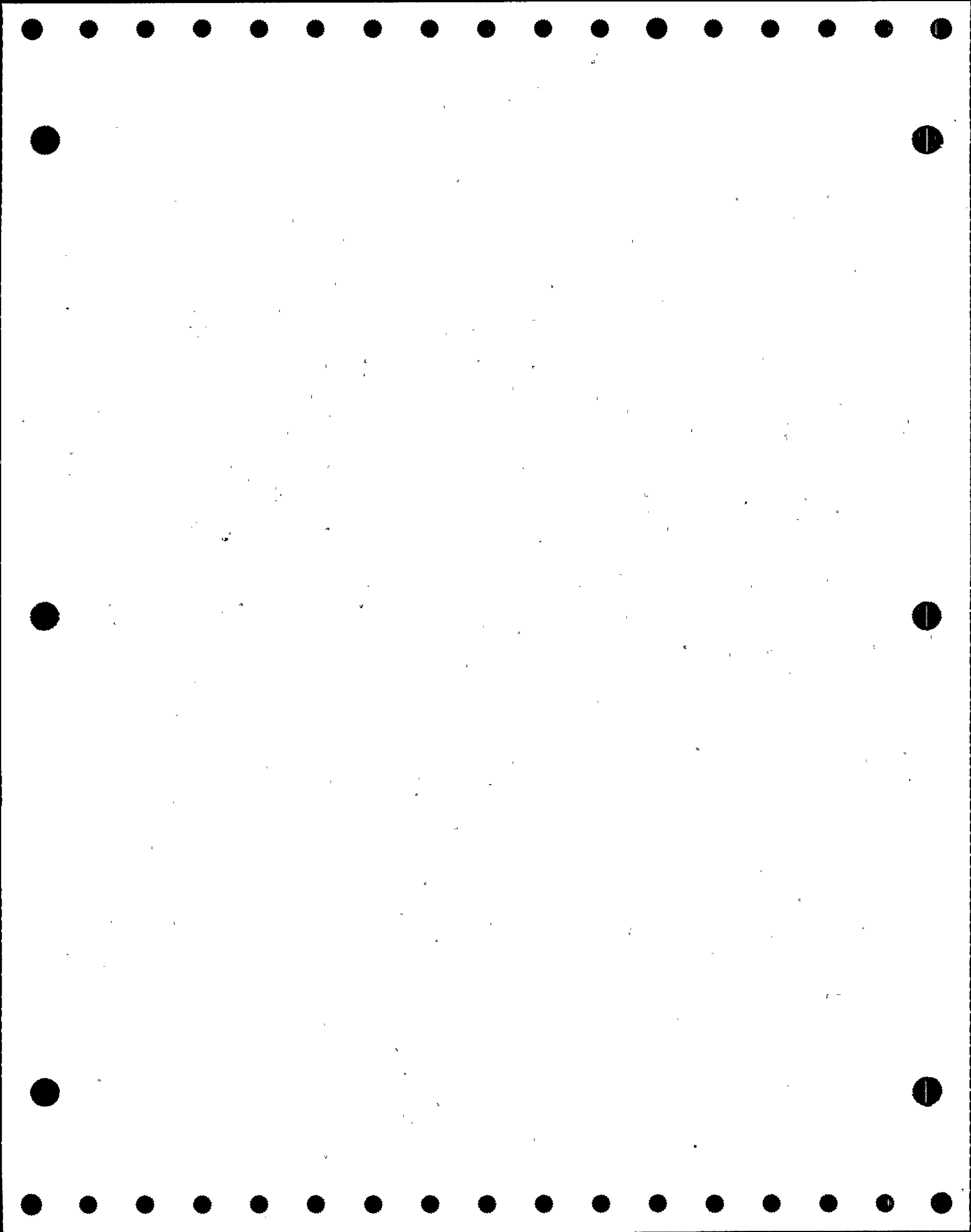

DONALD C. COOK NUCLEAR PLANT
 SECOND TEN YEAR INTERVAL
 VALVE SUMMARY SHEET - UNIT 1
 FLOW DIAGRAM: 1-5128A-37

RUN DATE AND TIME: 15FEB90:16:03

SYSTEM NAME: REACTOR COOLANT

VALVE				VALVE POSITION				ASME SECTION XI						
NUMBER	REV	TYPE	SIZE	ACT TYPE	F.D. COORD	POWER OPER	SAFETY FUNCT	CD [CL	A/P	CAT	PRIM TEST REQUIRED	TEST PERFORMED	TEST MODE	RELIEF REQUEST(S)
1-NSO-062	3	GL	1	SO	M/6	C	O/C	2	A	B	EF-1	EF-2	C	NO, CSJ 6
											EF-5	EF-5	-	NO, CSJ 6
											EF-7	EF-8	C	NO, CSJ 6
											ET-XXX	ET-XXX	C	NO, CSJ 6
1-NSO-063	3	GL	1	SO	M/6	C	O/C	2	A	B	EF-1	EF-2	C	NO, CSJ 6
											EF-5	EF-5	-	NO, CSJ 6
											EF-7	EF-8	C	NO, CSJ 6
											ET-XXX	ET-XXX	C	NO, CSJ 6
1-NSO-064	3	GL	1	SO	M/6	C	O/C	2	A	B	EF-1	EF-2	C	NO, CSJ 6
											EF-5	EF-5	-	NO, CSJ 6
											EF-7	EF-8	C	NO, CSJ 6
											ET-XXX	ET-XXX	C	NO, CSJ 6
1-PH-275	3	CK	3	SA	B/9	O/C	C	2	A	AC	CF-1	CF-2	R	YES, NOTE 4
											SLT-1	SLT-2	R	YES, NOTE 2
1-RCR-100	3	GL	0.375	A	B/7	O	C	2	A	A	EF-1	EF-1	P	NO
											EF-5	EF-5	-	NO
											EF-7	EF-7	P	NO
											ET-XXX	ET-XXX	P	NO
											SLT-1	SLT-2	R	YES, NOTE 2
1-RCR-101	3	GL	0.375	A	B/7	O	C	2	A	A	EF-1	EF-1	P	NO
											EF-5	EF-5	-	NO
											EF-7	EF-7	P	NO
											ET-XXX	ET-XXX	P	NO
											SLT-1	SLT-2	R	YES, NOTE 2

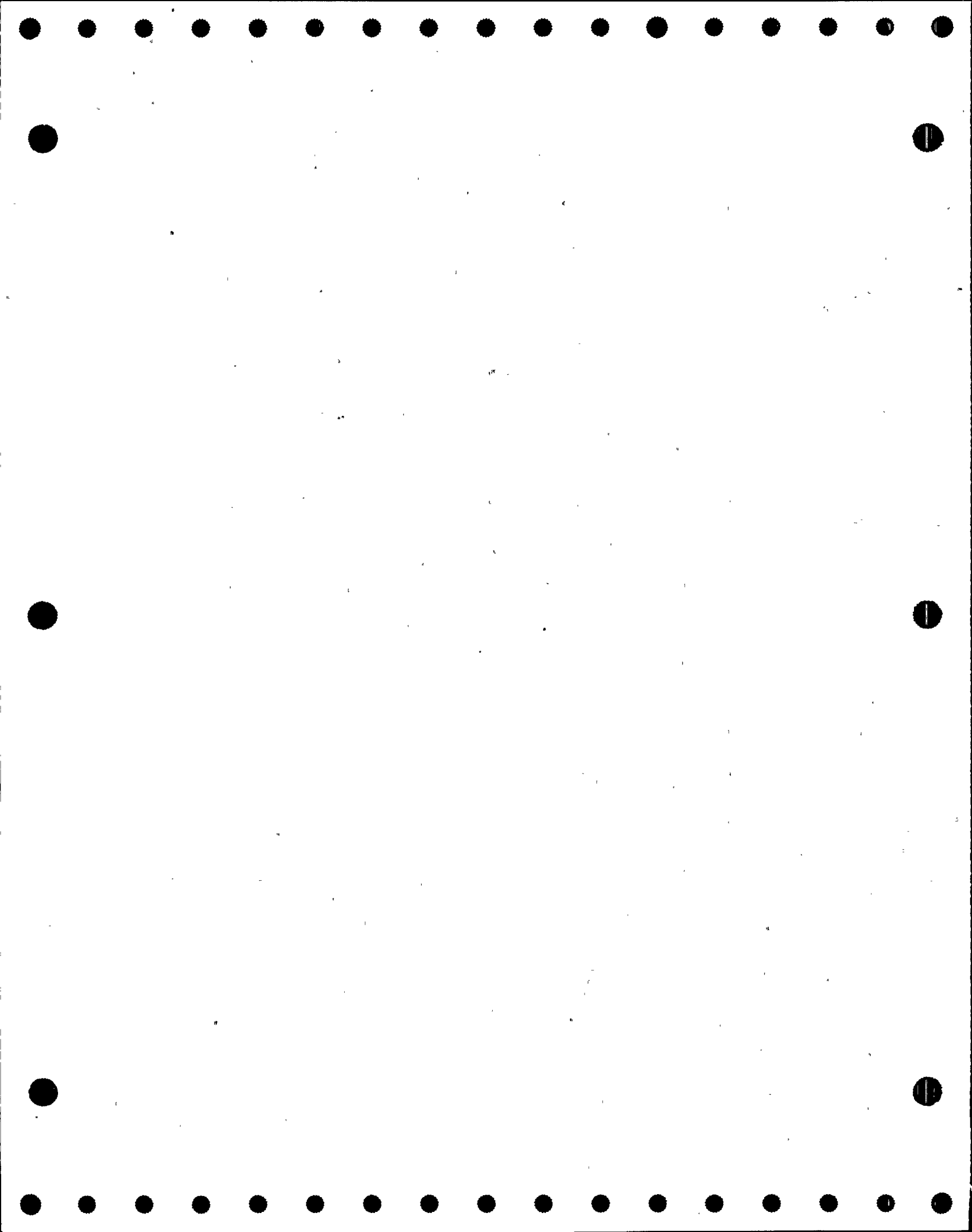

DONALD C. COOK NUCLEAR PLANT
 SECOND TEN YEAR INTERVAL
 VALVE SUMMARY SHEET - UNIT 1
 FLOW DIAGRAM: 1-5128A-37

RUN DATE AND TIME: 15FEB90:16:03

SYSTEM NAME: REACTOR COOLANT

VALVE				VALVE POSITION				ASME SECTION XI						
NUMBER	REV	TYPE	SIZE	ACT TYPE	F.D. COORD	POWER OPER	SAFETY FUNCT	CD ICL	A/P	CAT	PRIM TEST REQUIRED	TEST PERFORMED	TEST MODE	RELIEF REQUEST(S)
1-SI-189	3	CK	4	SA	D/7	C	O/C	2	A	AC	CF-1 SLT-1	CF-2 SLT-2	R R	YES, NOTE 7 YES, NOTE 2
1-SV-45A	3	REL	6	SA	K/6	C	0	1	A	C	TF-1	TF-1	R	NO
1-SV-45B	3	REL	6	SA	J/6	C	0	1	A	C	TF-1	TF-1	R	NO
1-SV-45C	3	REL	6	SA	H/6	C	0	1	A	C	TF-1	TF-1	R	NO
1-SV-50	3	REL	2	SA	G/3	C	0	3	A	C	TF-1	TF-1	R	NO

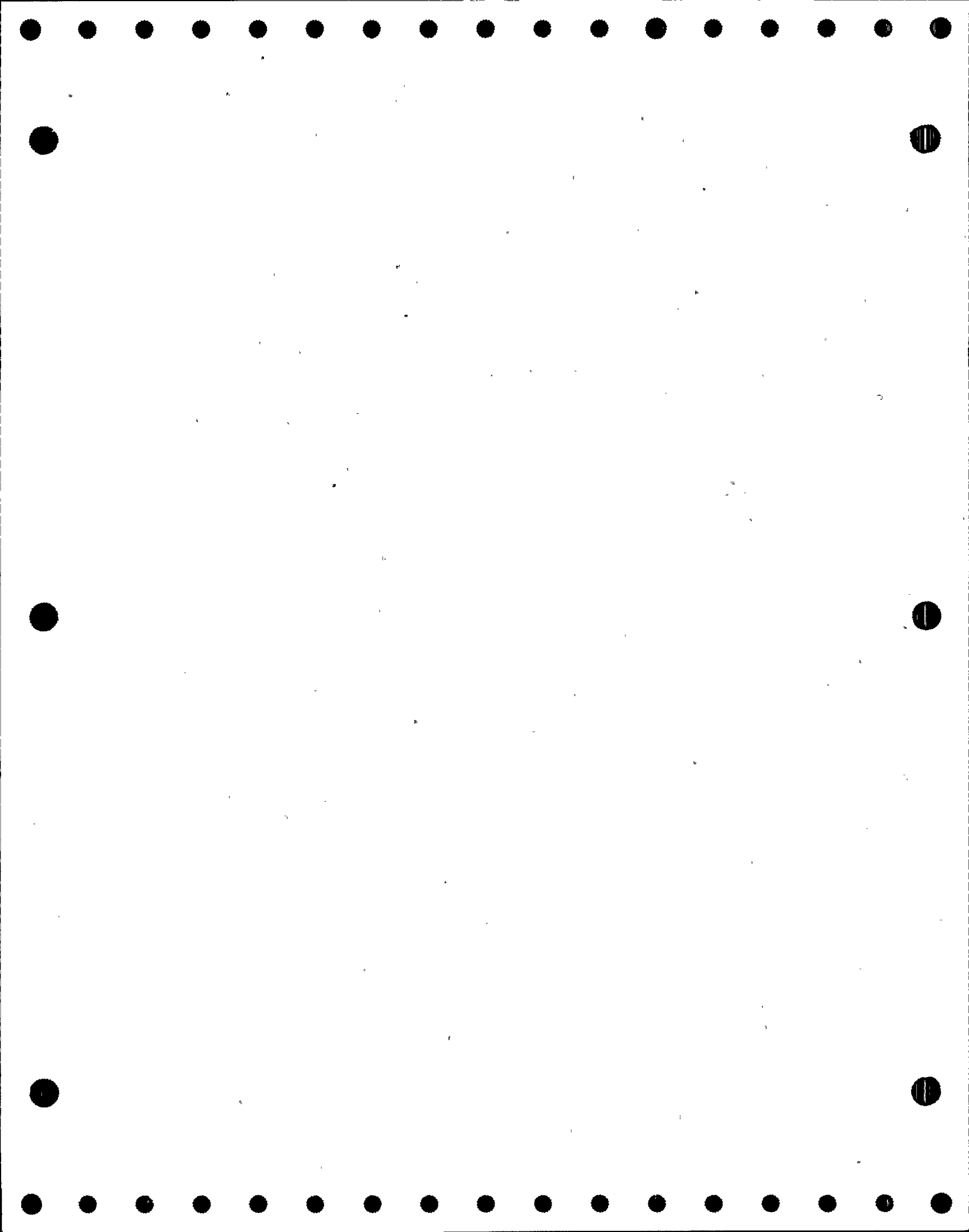

DONALD C. COOK NUCLEAR PLANT
 SECOND TEN YEAR INTERVAL
 VALVE SUMMARY SHEET - UNIT 1
 FLOW DIAGRAM: 1-5129-31

RUN DATE AND TIME: 15FEB90:16:03

SYSTEM NAME: CVCS - LETDOWN & CHARGING

VALVE				VALVE POSITION				ASME SECTION XI						
NUMBER	REV	TYPE	SIZE	ACT TYPE	F.D. COORD	POWER OPER	SAFETY FUNCT	CD ICL	A/P	CAT	PRIM TEST REQUIRED	TEST PERFORMED	TEST MODE	RELIEF REQUEST(S)
1-CS-292	3	CK	2	SA	H/6	C	O/C	2	A	C	CF-1	CF-2	C	YES, NOTE 1
1-CS-297-E	3	CK	2	SA	H/7	O/C	0	2	A	C	CF-1	CF-1	P	NO
1-CS-297-W	3	CK	2	SA	F/7	O/C	0	2	A	C	CF-1	CF-1	P	NO
1-CS-299-E	3	CK	4	SA	H/7	0	O/C	2	A	AC	CF-1 SLT-1	CF-3 SLT-1	P R	YES, NOTE 2 NO, NOTE 11
1-CS-299-W	3	CK	4	SA	F/7	0	O/C	2	A	AC	CF-1 SLT-1	CF-3 SLT-1	P R	YES, NOTE 2 NO, NOTE 11
1-CS-321	3	CK	3	SA	E/3	0	C/O	2	A	AC	CF-1 SLT-1	CF-2 SLT-2	R R	YES, NOTE 4 YES, NOTE 3
1-CS-328-L1	3	CK	3	SA	B/2	O/C	0	1	A	C	CF-1	CF-1	P	NO, NOTE 5
1-CS-328-L4	3	CK	3	SA	B/3	O/C	0	1	A	C	CF-1	CF-1	P	NO, NOTE 5
1-CS-329-L1	3	CK	3	SA	B/2	O/C	0	1	A	C	CF-1	CF-1	P	NO, NOTE 5
1-CS-329-L4	3	CK	3	SA	B/3	O/C	0	1	A	C	CF-1	CF-1	P	NO, NOTE 5
1-IMO-360	3	GA	4	MO	H/6	C	0	2	A	B	EF-1 EF-5 ET-XXX	EF-1 EF-5 ET-XXX	P - P	NO NO NO

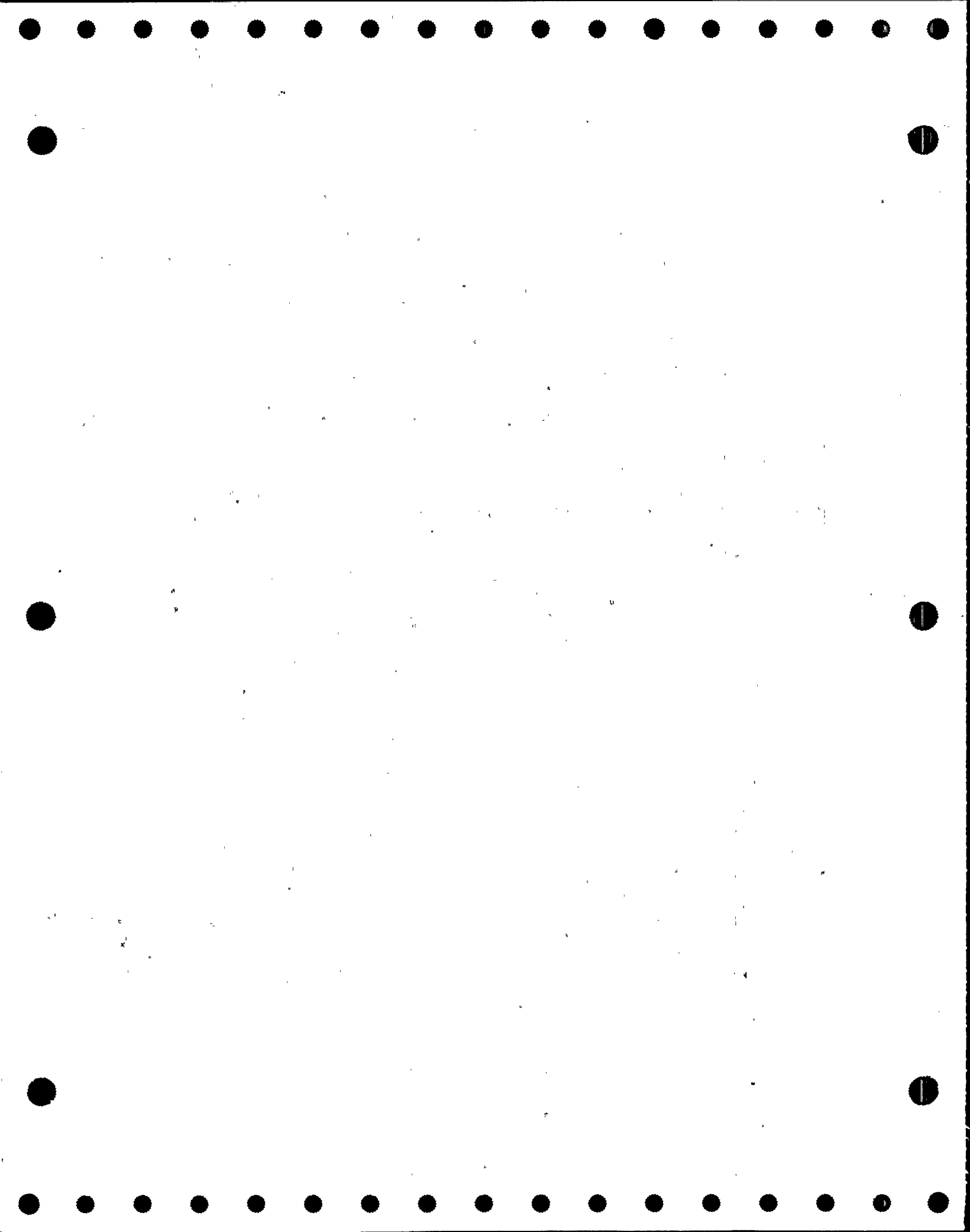

DONALD C. COOK NUCLEAR PLANT
 SECOND TEN YEAR INTERVAL
 VALVE SUMMARY SHEET - UNIT 1
 FLOW DIAGRAM: 1-5129-31

RUN DATE AND TIME: 15FEB90:16:03

SYSTEM NAME: CVCS - LETDOWN & CHARGING

VALVE				VALVE POSITION				ASME SECTION XI						
NUMBER	REV	TYPE	SIZE	ACT TYPE	F.D. COORD	POWER OPER	SAFETY FUNCT	CD ICL	A/P	CAT	PRIM TEST REQUIRED	TEST PERFORMED	TEST MODE	RELIEF REQUEST(S)
1-IMO-910	3	GA	8	MO	L/5	C	O	2	A	B	EF-1 EF-5 ET-XXX	EF-1 EF-5 ET-XXX	P - P	NO NO NO
1-IMO-911	3	GA	8	MO	L/6	C	O	2	A	B	EF-1 EF-5 ET-XXX	EF-1 EF-5 ET-XXX	P - P	NO NO NO
1-QCR-300	3	GL	2	A	E/1	O	C	2	A	A	EF-1 EF-5 EF-7 ET-XXX SLT-1	EF-2 EF-5 EF-8 ET-XXX SLT-2	C - C P R	NO, CSJ 6 NO NO, CSJ 6 NO, CSJ 6 YES, NOTE 3
1-QCR-301	3	GL	2	A	E/1	O	C	2	A	A	EF-1 EF-5 EF-7 ET-XXX SLT-1	EF-2 EF-5 EF-8 ET-XXX SLT-2	C - C P R	NO, CSJ 6 NO NO, CSJ 6 NO, CSJ 6 YES, NOTE 3
1-QMO-200	3	GA	3	MO	J/3	O	O/C	2	A	B	EF-1 EF-5 ET-XXX	EF-2 EF-5 ET-XXX	C - P	NO, CSJ 7 NO NO, CSJ 7
1-QMO-201	3	GA	3	MO	J/3	O	O/C	2	A	B	EF-1 EF-5 ET-XXX	EF-2 EF-5 ET-XXX	C - P	NO, CSJ 7 NO NO, CSJ 7
1-QMO-225	3	GA	2	MO	J/7	O	O/C	2	A	B	EF-1 EF-5 ET-XXX	EF-1 EF-5 ET-XXX	P - P	NO NO NO

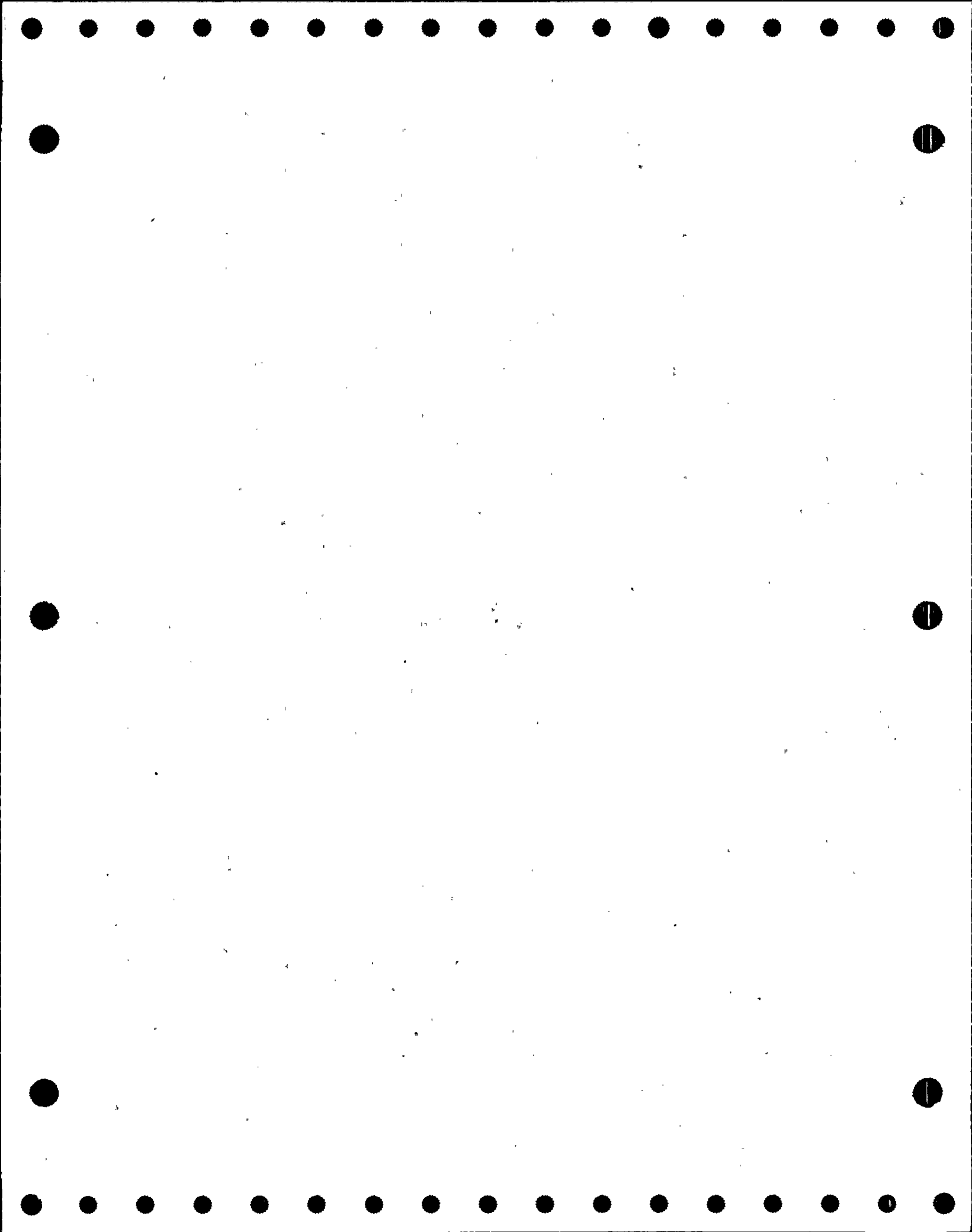

DONALD C. COOK NUCLEAR PLANT
 SECOND TEN YEAR INTERVAL
 VALVE SUMMARY SHEET - UNIT 1
 FLOW DIAGRAM: 1-5129-31

RUN DATE AND TIME: 15FEB90:16:03

SYSTEM NAME: CVCS - LETDOWN & CHARGING

VALVE				VALVE POSITION				ASME SECTION XI						
NUMBER	REV	TYPE	SIZE	ACT TYPE	F.D. COORD	POWER OPER	SAFETY FUNCT	CD ICL	A/P	CAT	PRIM TEST REQUIRED	TEST PERFORMED	TEST MODE	RELIEF REQUEST(S)
1-QM0-226	3	GA	2	MO	G/7	0	O/C	2	A	B	EF-1 EF-5 ET-XXX	EF-1 EF-5 ET-XXX	P - P	NO NO NO
1-QRV-200	3	GL	3	A	H/3	0	0	2	A	B	EF-1 EF-5 EF-7 ET-XXX	EF-3 EF-5 NOTE 8 NOTE 8	P - - -	NO, NOTE 8 YES, NOTE 8 YES, NOTE 8 YES, NOTE 8
1-QRV-251	3	GL	3	A	H/5	0	0	2	A	B	EF-1 EF-5 EF-7 ET-XXX	EF-3 EF-5 EF-8 NOTE 9	P - - -	NO, NOTE 9 YES, NOTE 9 YES, NOTE 9 YES, NOTE 9
1-QRV-61	3	GL	3	A	C/2	C	0	2	A	B	EF-1 EF-5 EF-7 ET-XXX	EF-1 EF-5 EF-7 ET-XXX	P - P P	NO NO NO NO
1-QRV-62	3	GL	3	A	C/2	O/C	0	2	A	B	EF-1 EF-5 EF-7 ET-XXX	EF-1 EF-5 EF-7 ET-XXX	P - P P	NO NO NO NO
1-SI-185	3	CK	8	SA	K/5	C	0	2	A	C	CF-1	CF-2	R	YES, NOTE 10
1-SV-51	3	REL	2	SA	E/2	C	0	2	A	C	TF-1	TF-1	R	NO

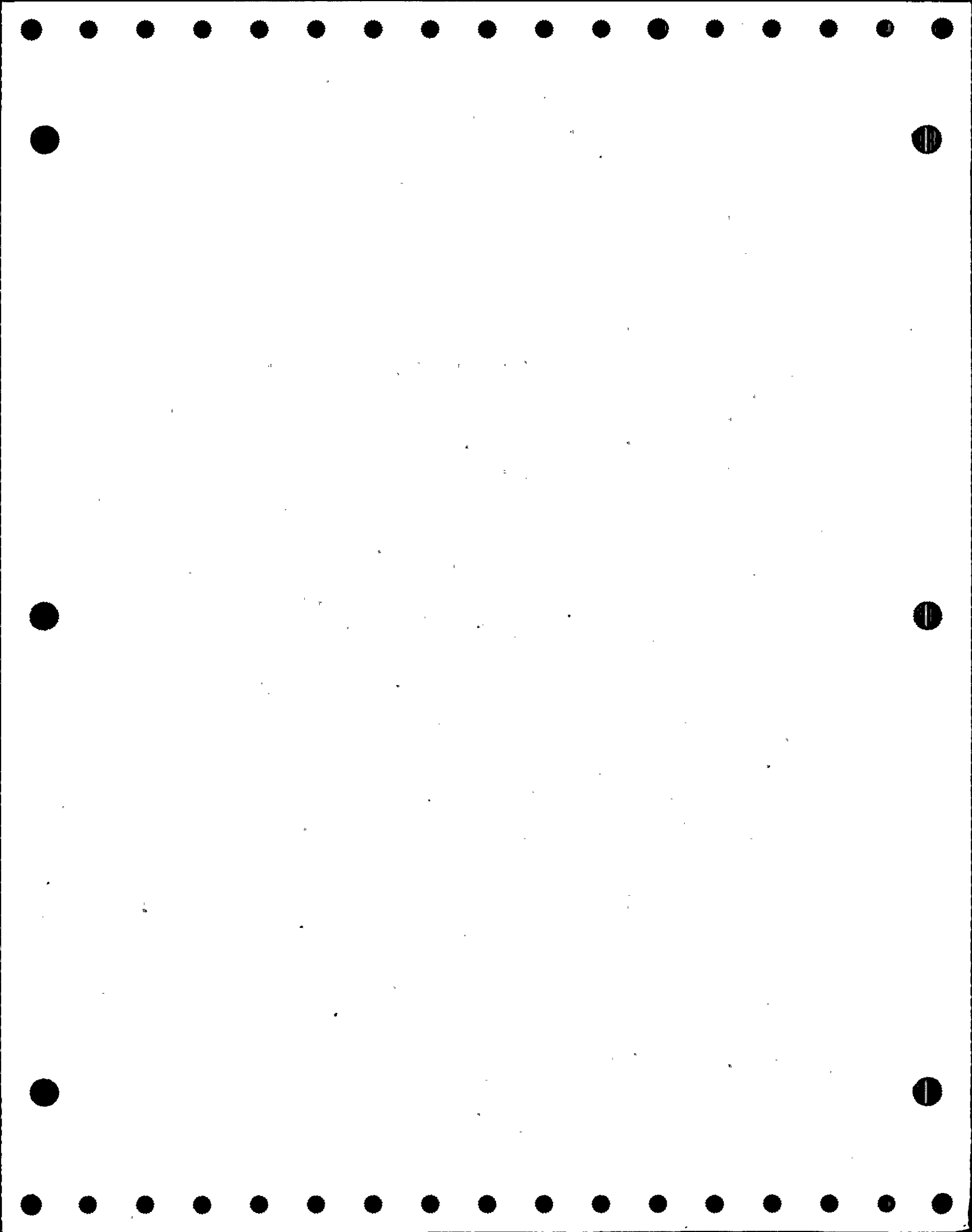

DONALD C. COOK NUCLEAR PLANT
 SECOND TEN YEAR INTERVAL
 VALVE SUMMARY SHEET - UNIT 1
 FLOW DIAGRAM: 1-5129-31

RUN DATE AND TIME: 15FEB90:16:03

SYSTEM NAME: CVCS - LETDOWN & CHARGING

VALVE				VALVE POSITION				ASME SECTION XI						
NUMBER	REV	TYPE	SIZE	ACT TYPE	F.D. COORD	POWER OPER	SAFETY FUNCT	CD ICL	A/P	CAT	PRIM TEST REQUIRED	TEST PERFORMED	TEST MODE	RELIEF REQUEST(S)
1-SV-52	3	REL	2	SA	K/1	C	0	2	A	C	TF-1	TF-1	R	NO
1-SV-55	3	REL	0.75	SA	K/7	C	0	2	A	C	TF-1	TF-1	R	NO
1-SV-56	3	REL	0.75	SA	L/6	C	0	2	A	C	TF-1	TF-1	R	NO

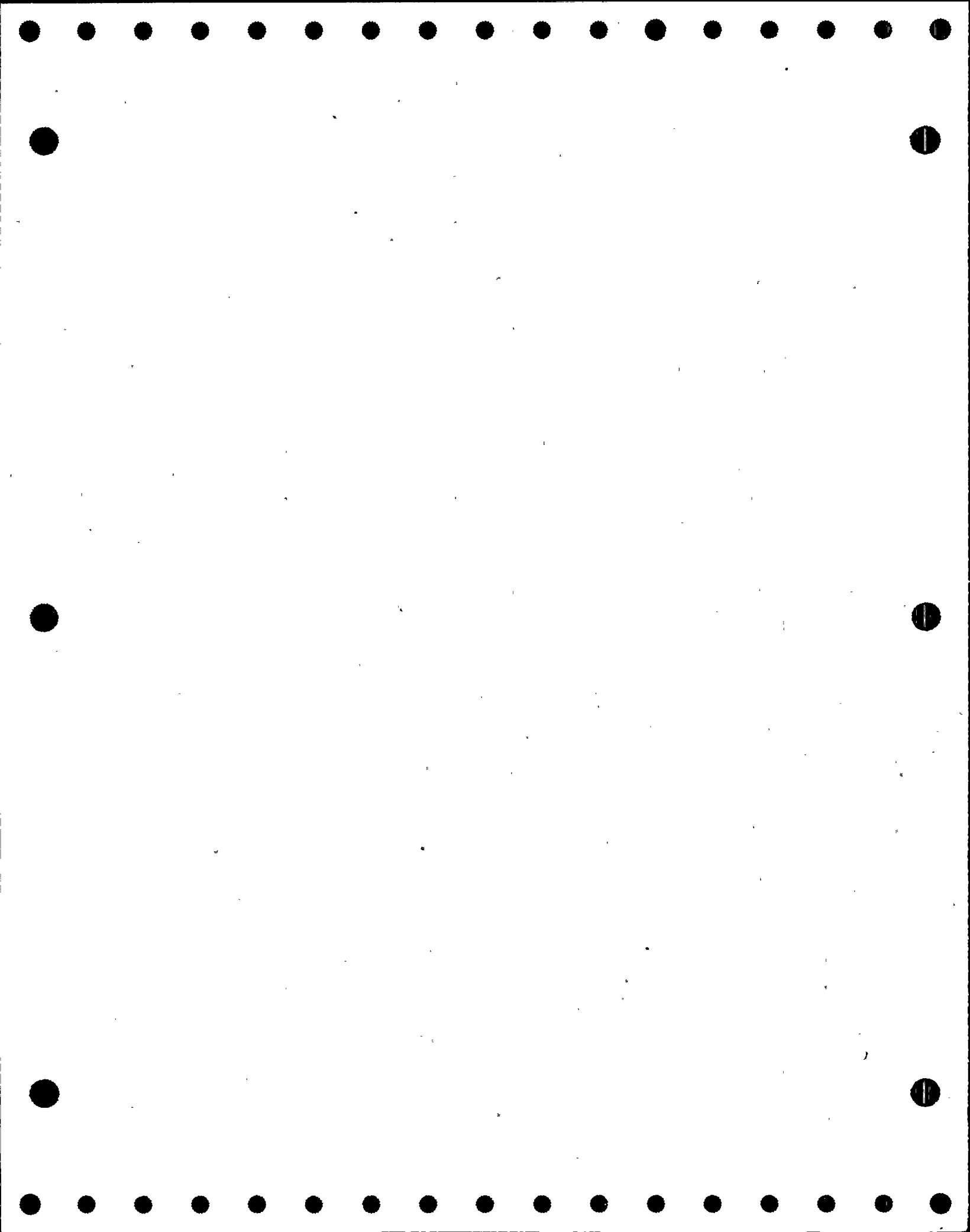

DONALD C. COOK NUCLEAR PLANT
 SECOND TEN YEAR INTERVAL
 VALVE SUMMARY SHEET - UNIT 1
 FLOW DIAGRAM: 1-5129A-19

RUN DATE AND TIME: 15FEB90:16:03

SYSTEM NAME: CVCS - LETDOWN & CHARGING

VALVE				VALVE POSITION				ASME SECTION XI						
NUMBER	REV	TYPE	SIZE	ACT TYPE	F.D. COORD	POWER OPER	SAFETY FUNCT	CD ICL	A/P	CAT	PRIM TEST REQUIRED	TEST PERFORMED	TEST MODE	RELIEF REQUEST(S)
1-QCM-250	3	GA	4	MO	C/8	0	C	2	A	A	EF-1 EF-5 ET-XXX SLT-1	EF-2 EF-5 ET-XXX SLT-2	C - C R	NO, CSJ 1 NO NO, CSJ 1 YES, NOTE 2
1-QCM-350	3	GA	4	MO	C/8	0	C	2	A	A	EF-1 EF-5 ET-XXX SLT-1	EF-2 EF-5 ET-XXX SLT-2	C - C R	NO, CSJ 1 NO NO, CSJ 1 YES, NOTE 2
1-QMO-451	3	GA	4	MO	J/5	0	C	2	A	B	EF-1 EF-5 ET-XXX	EF-2 EF-5 ET-XXX	C - C	NO, CSJ 3 NO NO, CSJ 3
1-QMO-452	3	GA	4	MO	J/5	0	C	2	A	B	EF-1 EF-5 ET-XXX	EF-2 EF-5 ET-XXX	C - C	NO, CSJ 3 NO NO, CSJ 3
1-QRV-400	3	GL	2	A	K/4	C	0	2	A	B	EF-1 EF-5 EF-7 ET-XXX	EF-1 EF-5 EF-7 ET-XXX	P - P P	NO NO NO NO
1-SV-53	3	REL	3	SA	H/2	C	0	2	A	C	TF-1	TF-1	R	NO
1-SV-54	3	REL	2	SA	E/4	C	0	2	A	C	TF-1	TF-1	R	NO

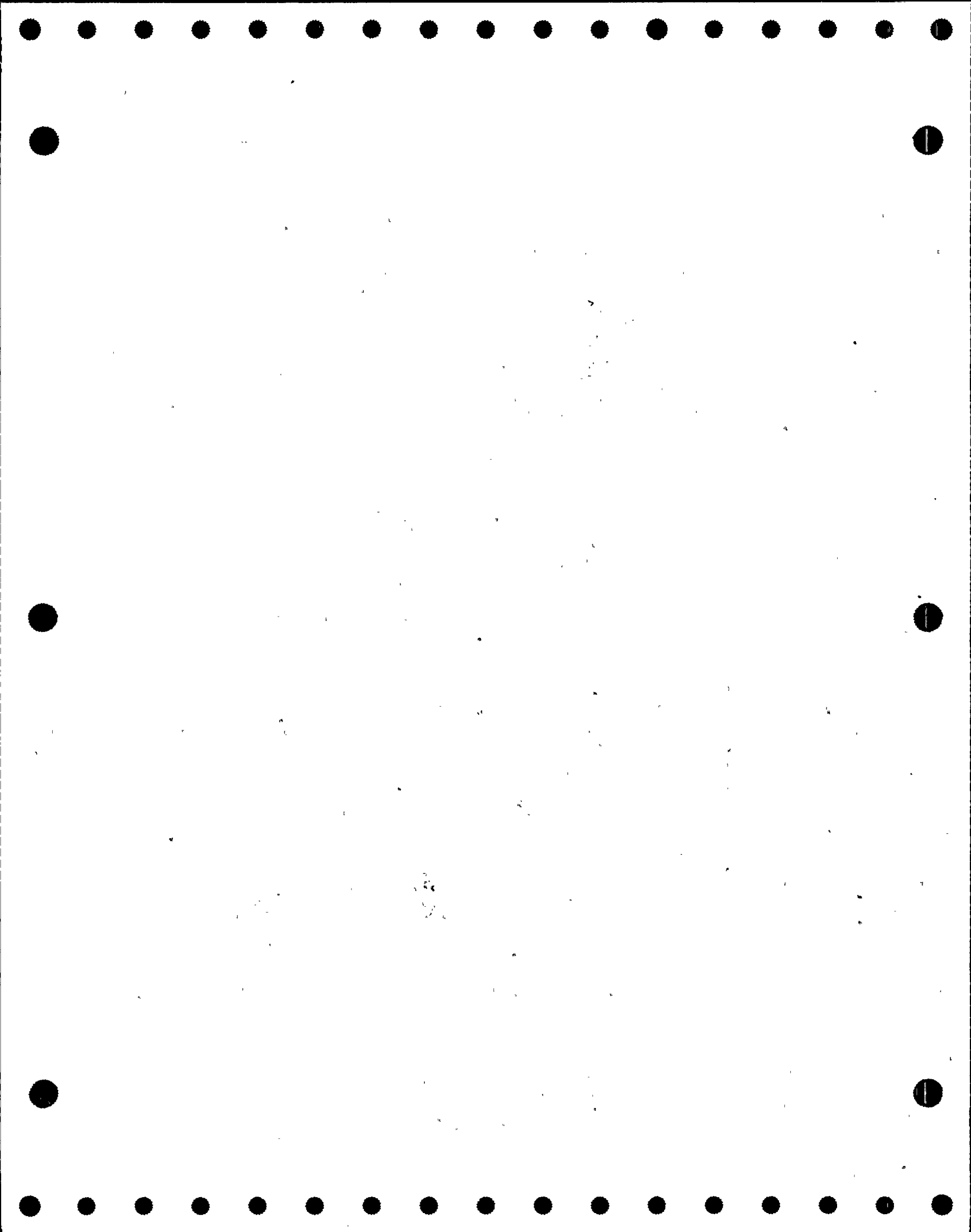

DONALD C. COOK NUCLEAR PLANT
 SECOND TEN YEAR INTERVAL
 VALVE SUMMARY SHEET - UNIT 1
 FLOW DIAGRAM: 1-5135-29

RUN DATE AND TIME: 15FEB90:16:03

SYSTEM NAME: COMPONENT COOLING

VALVE				VALVE POSITION				ASME SECTION XI						
NUMBER	REV	TYPE	SIZE	ACT TYPE	F.D. COORD	POWER OPER	SAFETY FUNCT	CD CL	A/P	CAT	PRIM TEST REQUIRED	TEST PERFORMED	TEST MODE	RELIEF REQUEST(S)
1-CCM-451	3	BF	8	MO	E/4	0	C	2	A	A	EF-1 EF-5 ET-XXX SLT-1	EF-2 EF-5 ET-XXX SLT-2	C - C R	NO, CSJ 1 NO NO, CSJ 1 YES, NOTE 2
1-CCM-452	3	BF	8	MO	E/5	0	C	2	A	A	EF-1 EF-5 ET-XXX SLT-1	EF-2 EF-5 ET-XXX SLT-2	C - C R	NO, CSJ 1 NO NO, CSJ 1 YES, NOTE 2
1-CCM-453	3	GL	4	MO	E/4	0	C	2	A	A	EF-1 EF-5 ET-XXX SLT-1	EF-2 EF-5 ET-XXX SLT-2	C - C R	NO, CSJ 1 NO NO, CSJ 1 YES, NOTE 2
1-CCM-454	3	GL	4	MO	E/5	0	C	2	A	A	EF-1 EF-5 ET-XXX SLT-1	EF-2 EF-5 ET-XXX SLT-2	C - C R	NO, CSJ 1 NO NO, CSJ 1 YES, NOTE 2
1-CCM-458	3	BF	8	MO	A/2	0	C	2	A	A	EF-1 EF-5 ET-XXX SLT-1	EF-2 EF-5 ET-XXX SLT-2	C - C R	NO, CSJ 1 NO NO, CSJ 1 YES, NOTE 2
1-CCM-459	3	BF	8	MO	B/2	0	C	2	A	A	EF-1 EF-5 ET-XXX SLT-1	EF-2 EF-5 ET-XXX SLT-2	C - C R	NO, CSJ 1 NO NO, CSJ 1 YES, NOTE 2

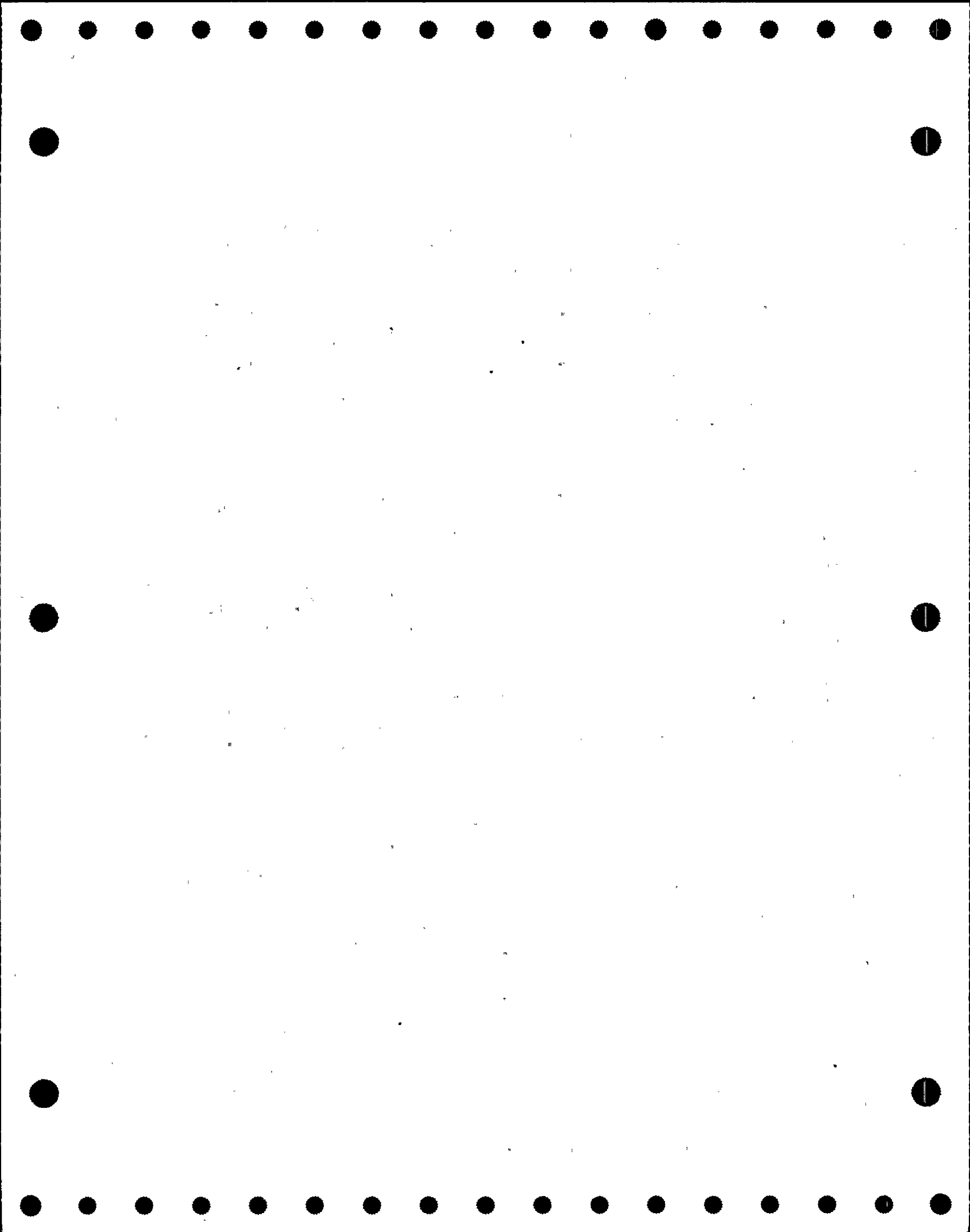

DONALD C. COOK NUCLEAR PLANT
 SECOND TEN YEAR INTERVAL
 VALVE SUMMARY SHEET - UNIT 1
 FLOW DIAGRAM: 1-5135-29

RUN DATE AND TIME: 15FEB90:16:03

SYSTEM NAME: COMPONENT COOLING

VALVE				VALVE POSITION				ASME SECTION XI						
NUMBER	REV	TYPE	SIZE	ACT TYPE	F.D. COORD	POWER OPER	SAFETY FUNCT	CD ICL	A/P	CAT	PRIM TEST REQUIRED	TEST PERFORMED	TEST MODE	RELIEF REQUEST(S)
1-CCR-455	3	GL	2	A	B/3	O	C	2	A	A	EF-1	EF-2	C	NO, CSJ 3
											EF-5	EF-5	-	NO
											EF-7	EF-8	C	NO, CSJ 3
											ET-XXX	ET-XXX	C	NO, CSJ 3
											SLT-1	SLT-2	R	YES, NOTE 2
1-CCR-456	3	GL	2	A	D/4	O	C	2	A	A	EF-1	EF-2	C	NO, CSJ 3
											EF-5	EF-5	-	NO
											EF-7	EF-8	C	NO, CSJ 3
											ET-XXX	ET-XXX	C	NO, CSJ 3
											SLT-1	SLT-2	R	YES, NOTE 2
1-CCR-457	3	GL	2	A	D/4	O	C	2	A	A	EF-1	EF-2	C	NO, CSJ 3
											EF-5	EF-5	-	NO
											EF-7	EF-8	C	NO, CSJ 3
											ET-XXX	ET-XXX	C	NO, CSJ 3
											SLT-1	SLT-2	R	YES, NOTE 2
1-CCR-460	3	GL	3	A	C/4	O	C	2	A	A	EF-1	EF-1	P	NO
											EF-5	EF-5	-	NO
											EF-7	EF-7	P	NO
											ET-XXX	ET-XXX	P	NO
											SLT-1	SLT-2	R	YES, NOTE 2
1-CCR-462	3	GL	3	A	A/4	O	C	2	A	A	EF-1	EF-1	P	NO
											EF-5	EF-5	-	NO
											EF-7	EF-7	P	NO
											ET-XXX	ET-XXX	P	NO
											SLT-1	SLT-2	R	YES, NOTE 2

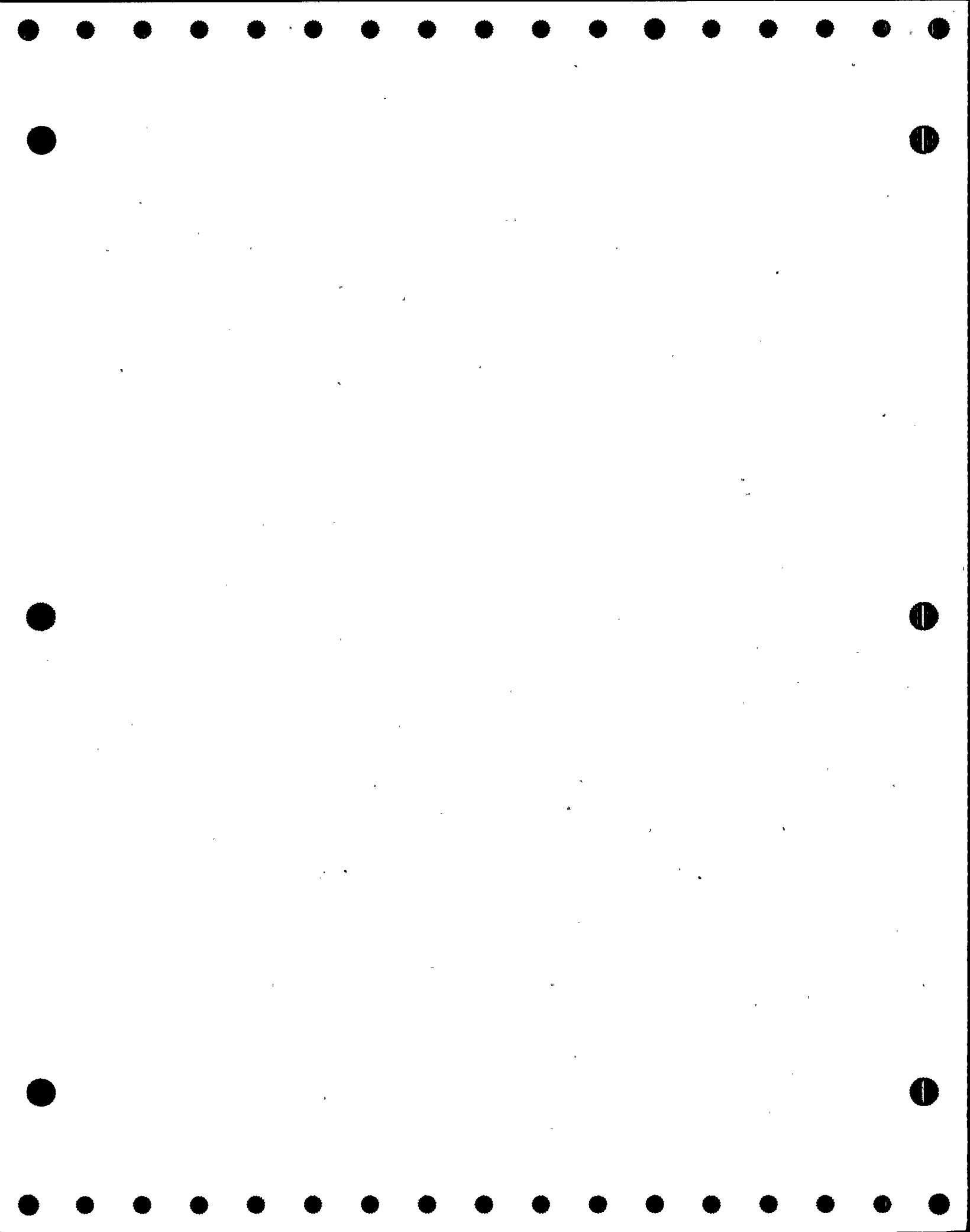

DONALD C. COOK NUCLEAR PLANT
 SECOND TEN YEAR INTERVAL
 VALVE SUMMARY SHEET - UNIT 1
 FLOW DIAGRAM: 1-5135-29

RUN DATE AND TIME: 15FEB90:16:03

SYSTEM NAME: COMPONENT COOLING

VALVE				VALVE POSITION				ASME SECTION XI						
NUMBER	REV	TYPE	SIZE	ACT TYPE	F.D. COORD	POWER OPER	SAFETY FUNCT	CD ICL	A/P	CAT	PRIM TEST REQUIRED	TEST PERFORMED	TEST MODE	RELIEF REQUEST(S)
1-CCH-135	3	CK	2.5	SA	B/3	0	C	2	A	AC	CF-1 SLT-1	CF-2 SLT-2	R R	YES, NOTE 4 YES, NOTE 2
1-CRV-445	3	BL	6	A	L/5	0	C/O	3	A	B	EF-1 EF-5 EF-7 ET-XXX	EF-1 EF-5 EF-7 ET-XXX	P - P P	NO NO NO NO
1-CRV-470	3	GL	6	A	G/1	0	C	3	A	B	EF-1 EF-5 EF-7 ET-XXX	EF-1 NOTE 5 NOTE 5 NOTE 5	P - - -	NO, NOTE 5 YES, NOTE 5 YES, NOTE 5 YES, NOTE 5
1-CRV-485	3	BF	10	A	B/7	0	C	3	A	B	EF-1 EF-5 EF-7 ET-XXX	EF-1 EF-5 EF-7 ET-XXX	P - P P	NO NO NO NO
1-SV-122-37	3	REL	1	SA	D/3	C	0	3	A	C	TF-1	TF-1	R	NO
1-SV-62-1	3	REL	1	SA	D/3	C	0	3	A	C	TF-1	TF-1	R	NO
1-SV-62-2	3	REL	1	SA	D/3	C	0	3	A	C	TF-1	TF-1	R	NO
1-SV-62-3	3	REL	1	SA	D/3	C	0	3	A	C	TF-1	TF-1	R	NO
1-SV-62-4	3	REL	1	SA	D/3	C	0	3	A	C	TF-1	TF-1	R	NO

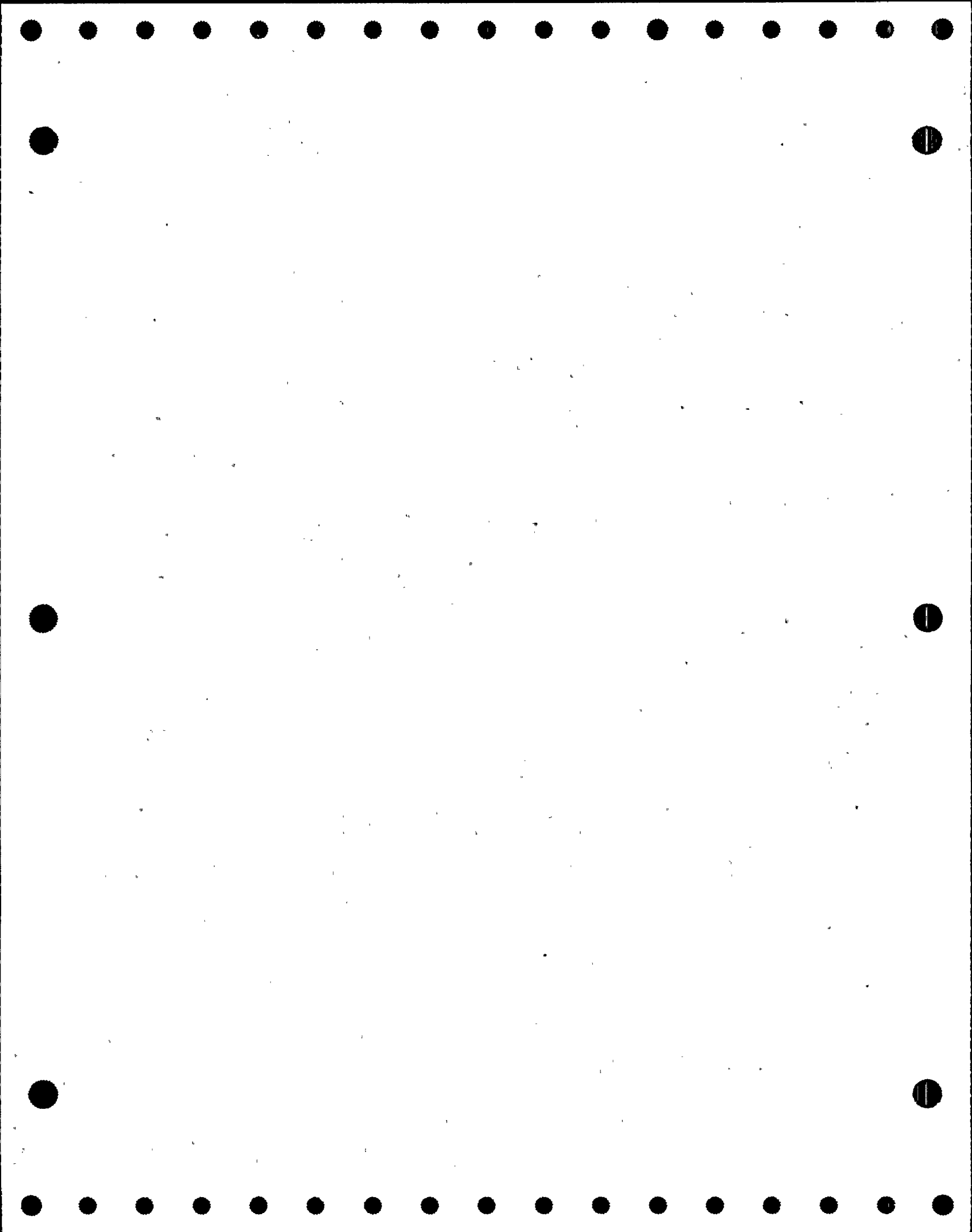

DONALD C. COOK NUCLEAR PLANT
 SECOND TEN YEAR INTERVAL
 VALVE SUMMARY SHEET - UNIT 1
 FLOW DIAGRAM: 1-5135-29

RUN DATE AND TIME: 15FEB90:16:03

SYSTEM NAME: COMPONENT COOLING

VALVE				VALVE POSITION				ASME SECTION XI						
NUMBER	REV	TYPE	SIZE	ACT TYPE	F.D. COORD	POWER OPER	SAFETY FUNCT	CD ICL	A/P	CAT	PRIM TEST REQUIRED	TEST PERFORMED	TEST MODE	RELIEF REQUEST(S)
1-SV-63	3	REL	1	SA	E/3	C	0	3	A	C	TF-1	TF-1	R	NO
1-SV-64	3	REL	1	SA	C/3	C	0	3	A	C	TF-1	TF-1	R	NO
1-SV-65	3	REL	1	SA	H/1	C	0	3	A	C	TF-1	TF-1	R	NO
1-SV-68	3	REL	1	SA	J/2	C	0	3	A	C	TF-1	TF-1	R	NO
1-SV-71	3	REL	1	SA	L/3	C	0	3	A	C	TF-1	TF-1	R	NO

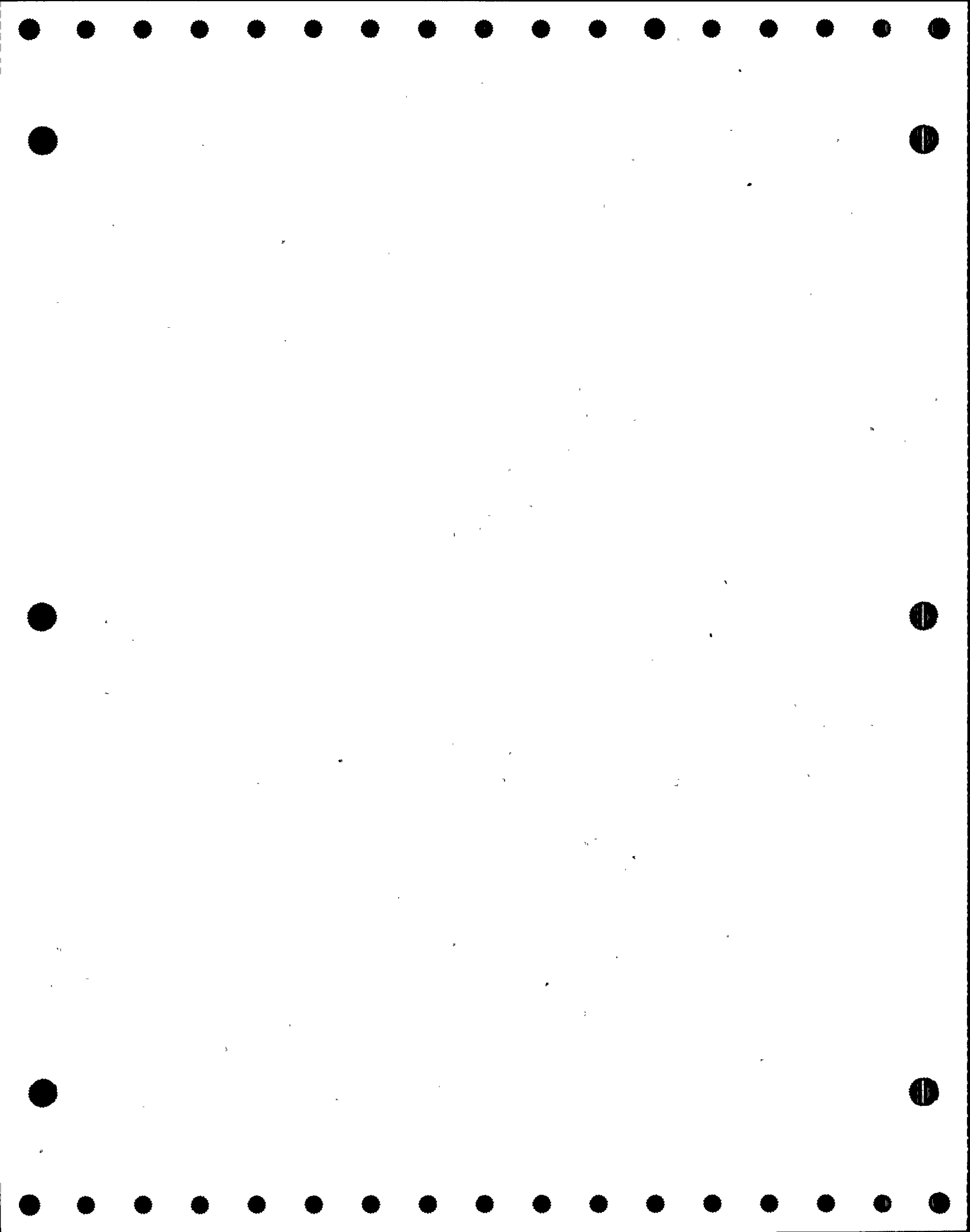

DONALD C. COOK NUCLEAR PLANT
 SECOND TEN YEAR INTERVAL
 VALVE SUMMARY SHEET - UNIT 1
 FLOW DIAGRAM: 1-5135A-30

RUN DATE AND TIME: 15FEB90:16:03

SYSTEM NAME: COMPONENT COOLING

VALVE				VALVE POSITION				ASME SECTION XI						
NUMBER	REV	TYPE	SIZE	ACT TYPE	F.D. COORD	POWER OPER	SAFETY FUNCT	CD ICL	A/P	CAT	PRIM TEST REQUIRED	TEST PERFORMED	TEST MODE	RELIEF REQUEST(S)
1-CCN-176-E	3	CK	16	SA	L/4	C/O	0	3	A	C	CF-1	CF-1	P	NO
1-CCN-176-W	3	CK	16	SA	K/4	C/O	0	3	A	C	CF-1	CF-1	P	NO
1-CMO-410	3	BF	16	MO	H/4	C/O	0	3	A	B	EF-1 EF-5 ET-XXX	EF-1 EF-5 ET-XXX	P - P	NO NO NO
1-CMO-411	3	BF	18	MO	M/5	0	C	3	A	B	EF-1 EF-5 ET-XXX	EF-1 EF-5 ET-XXX	P - P	NO NO NO, NOTE 2
1-CMO-412	3	BF	16	MO	L/3	0	C	3	A	B	EF-1 EF-5 ET-XXX	EF-1 EF-5 ET-XXX	P - P	NO NO NO, NOTE 2
1-CMO-413	3	BF	18	MO	L/5	0	C	3	A	B	EF-1 EF-5 ET-XXX	EF-1 EF-5 ET-XXX	P - P	NO NO NO, NOTE 2
1-CMO-414	3	BF	16	MO	K/3	0	C	3	A	B	EF-1 EF-5 ET-XXX	EF-1 EF-5 ET-XXX	P - P	NO NO NO, NOTE 2
1-CMO-415	3	BF	16	MO	H/5	0	C	3	A	B	EF-1 EF-5 ET-XXX	EF-1 EF-5 ET-XXX	P - P	NO NO NO, NOTE 2

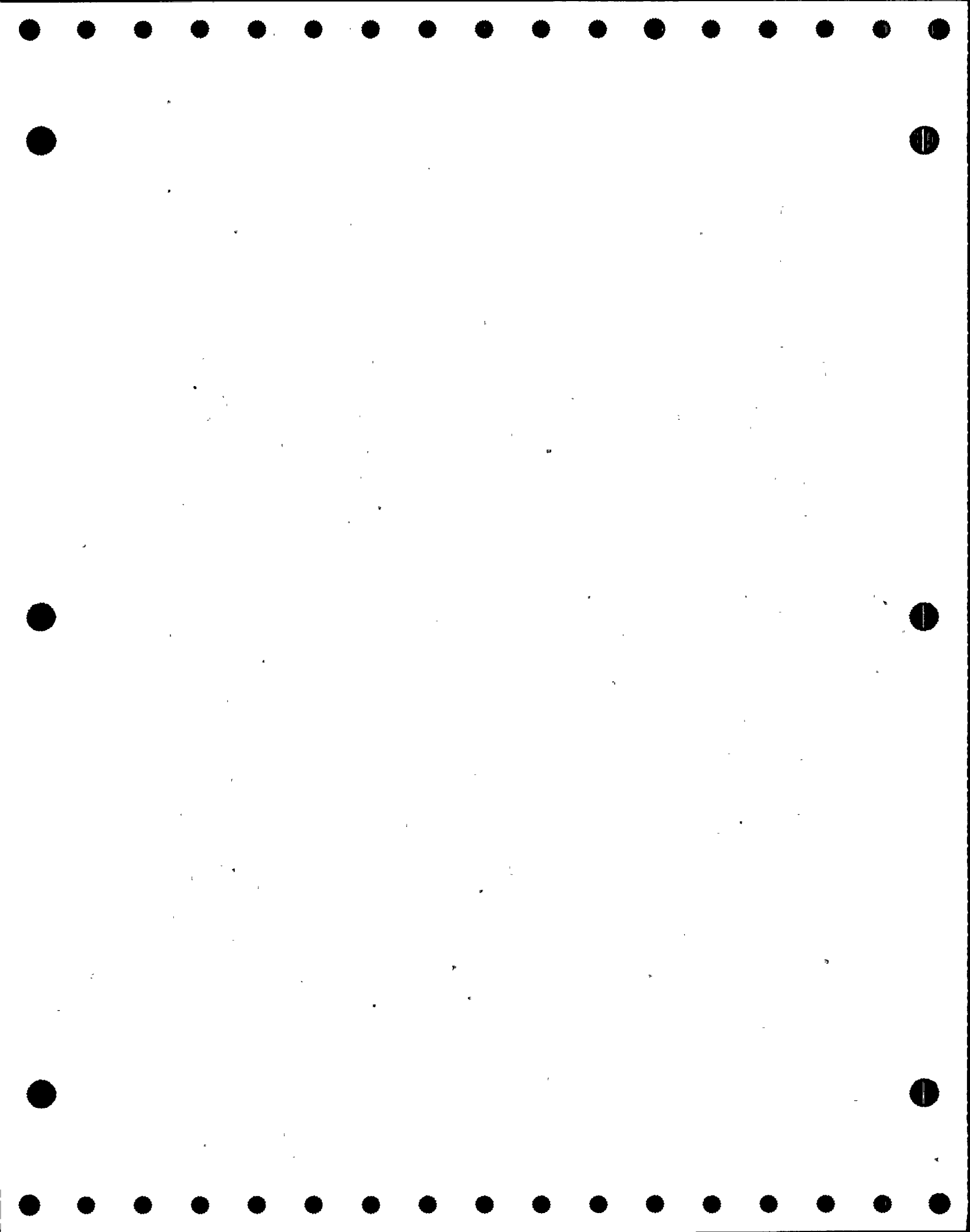

DONALD C. COOK NUCLEAR PLANT
 SECOND TEN YEAR INTERVAL
 VALVE SUMMARY SHEET - UNIT 1
 FLOW DIAGRAM: 1-5135A-30

RUN DATE AND TIME: 15FEB90:16:03

SYSTEM NAME: COMPONENT COOLING

VALVE				VALVE POSITION				ASME SECTION XI					
NUMBER	REV	TYPE	SIZE	ACT TYPE	F.D. COORD	POWER OPER	SAFETY FUNCT	CD A/P ICL	CAT	PRIM TEST REQUIRED	TEST PERFORMED	TEST MODE	RELIEF REQUEST(S)
1-CMO-416	3	BF	16	MO	G/5	O	C	3	A B	EF-1 EF-5 ET-XXX	EF-1 EF-5 ET-XXX	P - P	NO NO NO, NOTE 2
1-CMO-419	3	BF	14	MO	E/5	C	O	3	A B	EF-1 EF-5 ET-XXX	EF-1 EF-5 ET-XXX	P - P	NO NO NO
1-CMO-420	3	BF	16	MO	H/4	C/O	O	3	A B	EF-1 EF-5 ET-XXX	EF-1 EF-5 ET-XXX	P - P	NO NO NO
1-CMO-429	3	BF	14	MO	E/5	C	O	3	A B	EF-1 EF-5 ET-XXX	EF-1 EF-5 ET-XXX	P - P	NO NO NO
1-CRV-412	3	GL	4	A	K/1	O	C	3	A B	EF-1 EF-5 EF-7 ET-XXX	EF-1 EF-5 EF-7 ET-XXX	P - P P	NO NO NO NO
1-SV-60	3	REL	3	SA	L/1	C	O	3	A C	TF-1	TF-1	R	NO
1-SV-72	3	REL	1	SA	E/5	C	O	3	A C	TF-1	TF-1	R	NO
12-CCN-170	3	CK	16	SA	M/4	C	O	3	A C	CF-1	CF-4	-	NO, NOTE 1

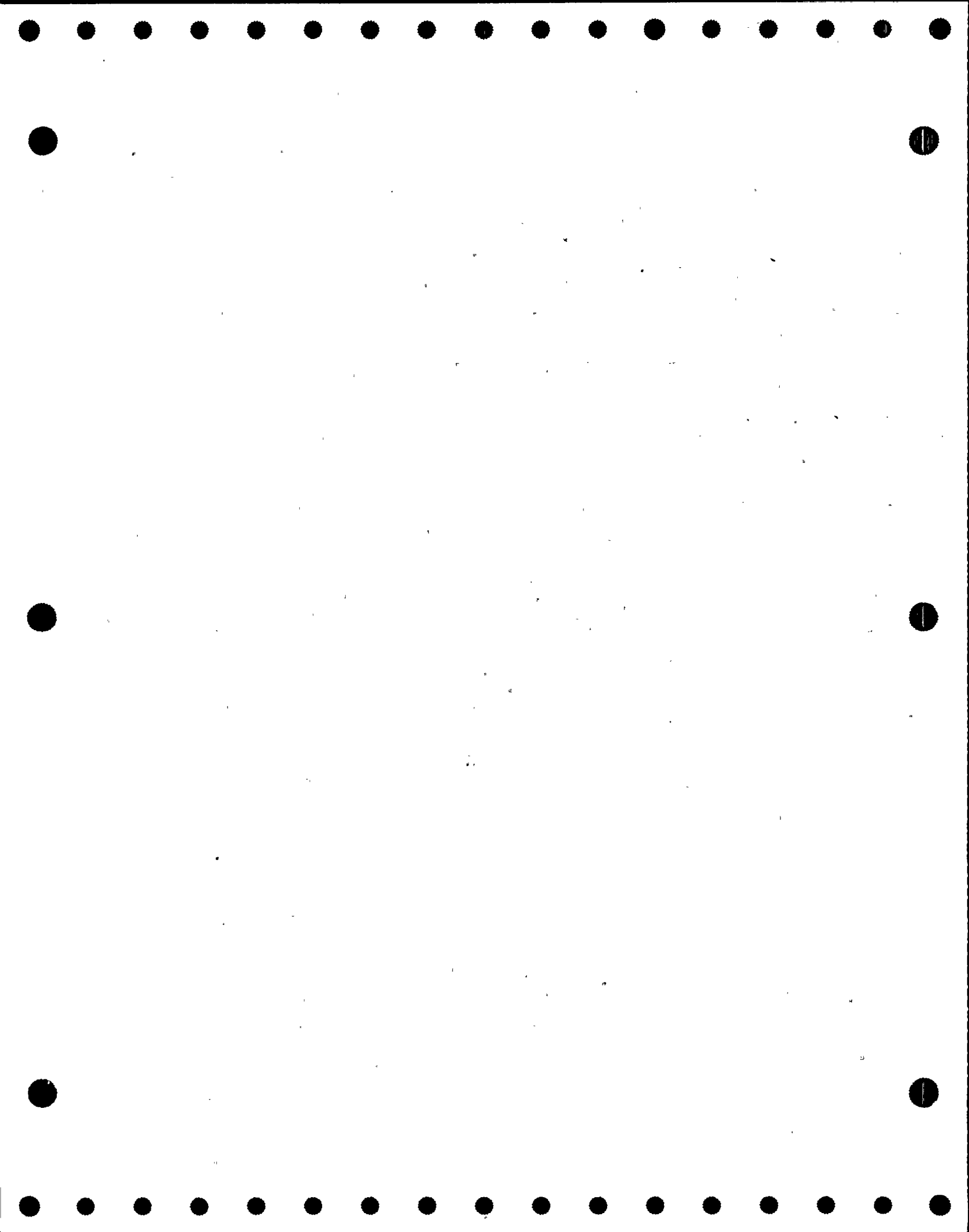

DONALD C. COOK NUCLEAR PLANT
 SECOND TEN YEAR INTERVAL
 VALVE SUMMARY SHEET - UNIT 1
 FLOW DIAGRAM: 1-5135B-14

RUN DATE AND TIME: 15FEB90:16:03

SYSTEM NAME: COMPONENT COOLING

VALVE				VALVE POSITION				ASME SECTION XI						
NUMBER	REV	TYPE	SIZE	ACT TYPE	F.D. COORD	POWER OPER	SAFETY FUNCT	CD CL	A/P	CAT	PRIM TEST REQUIRED	TEST PERFORMED	TEST MODE	RELIEF REQUEST(S)
1-CCM-430	3	GL	1.5	MO	D/6	C	O/C	2	A	A	EF-1 EF-5 ET-XXX SLT-1	EF-1 EF-5 ET-XXX SLT-2	P - P R	NO NO NO YES, NOTE 1
1-CCM-431	3	GL	1.5	MO	D/6	C	O/C	2	A	A	EF-1 EF-5 ET-XXX SLT-1	EF-1 EF-5 ET-XXX SLT-2	P - P R	NO NO NO YES, NOTE 1
1-CCM-432	3	GL	1.5	MO	D/6	C	O/C	2	A	A	EF-1 EF-5 ET-XXX SLT-1	EF-1 EF-5 ET-XXX SLT-2	P - P R	NO NO NO YES, NOTE 1
1-CCM-433	3	GL	1.5	MO	D/6	C	O/C	2	A	A	EF-1 EF-5 ET-XXX SLT-1	EF-1 EF-5 ET-XXX SLT-2	P - P R	NO NO NO YES, NOTE 1
1-CCR-440	3	GL	1.5	A	D/6	O	C	2	A	A	EF-1 EF-5 EF-7 ET-XXX SLT-1	EF-1 EF-5 EF-7 ET-XXX SLT-2	P - P P R	NO NO NO NO YES, NOTE 1
1-CCR-441	3	GL	1.5	A	D/6	O	C	2	A	A	EF-1 EF-5 EF-7 ET-XXX SLT-1	EF-1 EF-5 EF-7 ET-XXX SLT-2	P - P P R	NO NO NO NO YES, NOTE 1

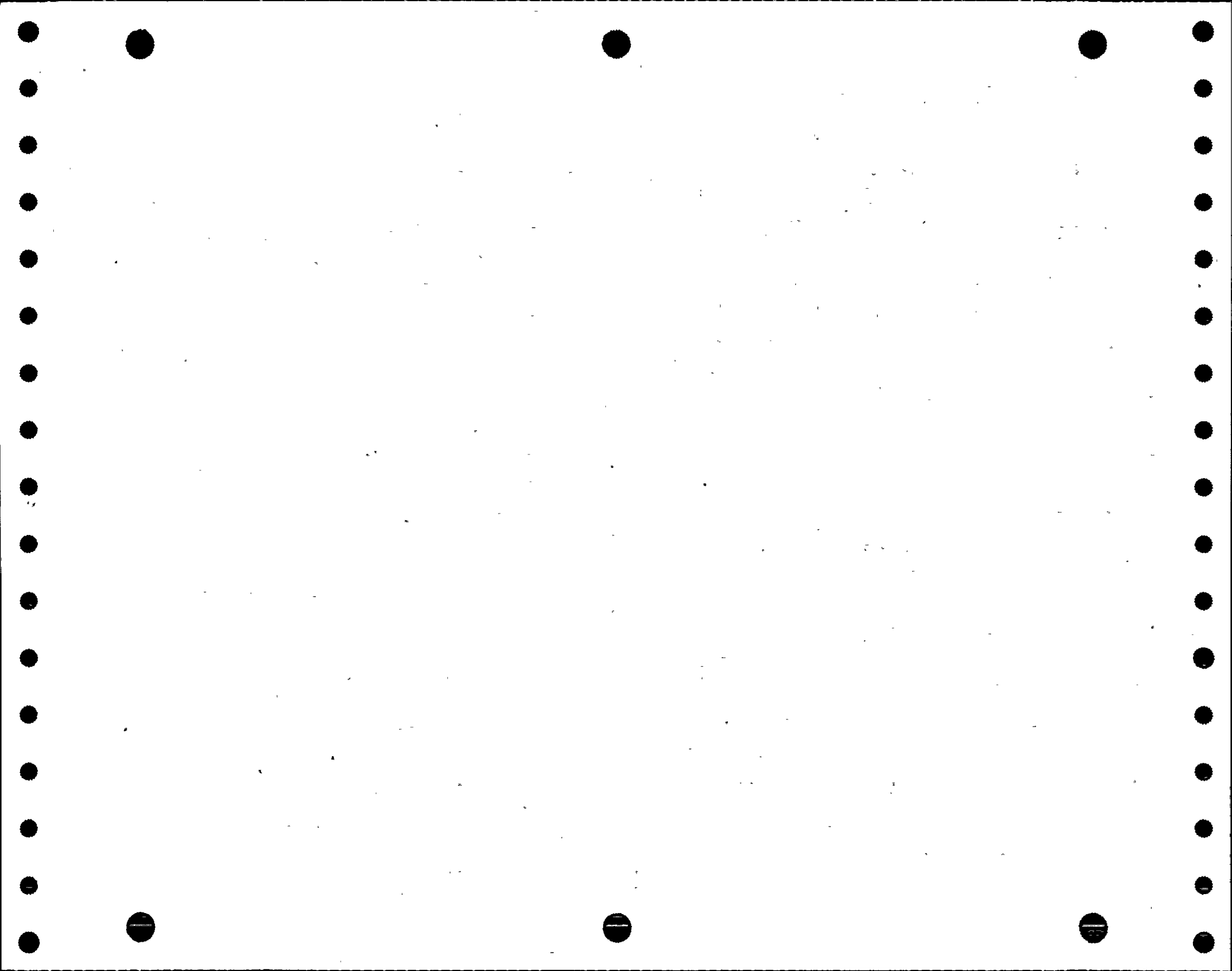

DONALD C. COOK NUCLEAR PLANT
 SECOND TEN YEAR INTERVAL
 VALVE SUMMARY SHEET - UNIT 1
 FLOW DIAGRAM: 1-5135B-14

RUN DATE AND TIME: 15FEB90:16:03

SYSTEM NAME: COMPONENT COOLING

VALVE				VALVE POSITION				ASME SECTION XI						
NUMBER	REV	TYPE	SIZE	ACT TYPE	F.D. COORD	POWER OPER	SAFETY FUNCT	CD ICL	A/P	CAT	PRIM TEST REQUIRED	TEST PERFORMED	TEST MODE	RELIEF REQUEST(S)
1-CCW-243-25	3	CK	1	SA	C/5	0	C	2	A	AC	CF-1 SLT-1	CF-2 SLT-2	R R	YES, NOTE 2 YES, NOTE 1
1-CCW-243-72	3	CK	1	SA	C/5	0	C	2	A	AC	CF-1 SLT-1	CF-2 SLT-2	R R	YES, NOTE 2 YES, NOTE 1
1-CCW-244-25	3	CK	1	SA	C/6	0	C	2	A	AC	CF-1 SLT-1	CF-2 SLT-2	R R	YES, NOTE 2 YES, NOTE 1
1-CCW-244-72	3	CK	1	SA	C/6	0	C	2	A	AC	CF-1 SLT-1	CF-2 SLT-2	R R	YES, NOTE 2 YES, NOTE 1
1-SV-122-25B	3	REL	1.5	SA	B/6	C	0	3	A	C	TF-1	TF-1	R	NO
1-SV-122-72B	3	REL	1.5	SA	B/6	C	0	3	A	C	TF-1	TF-1	R	NO

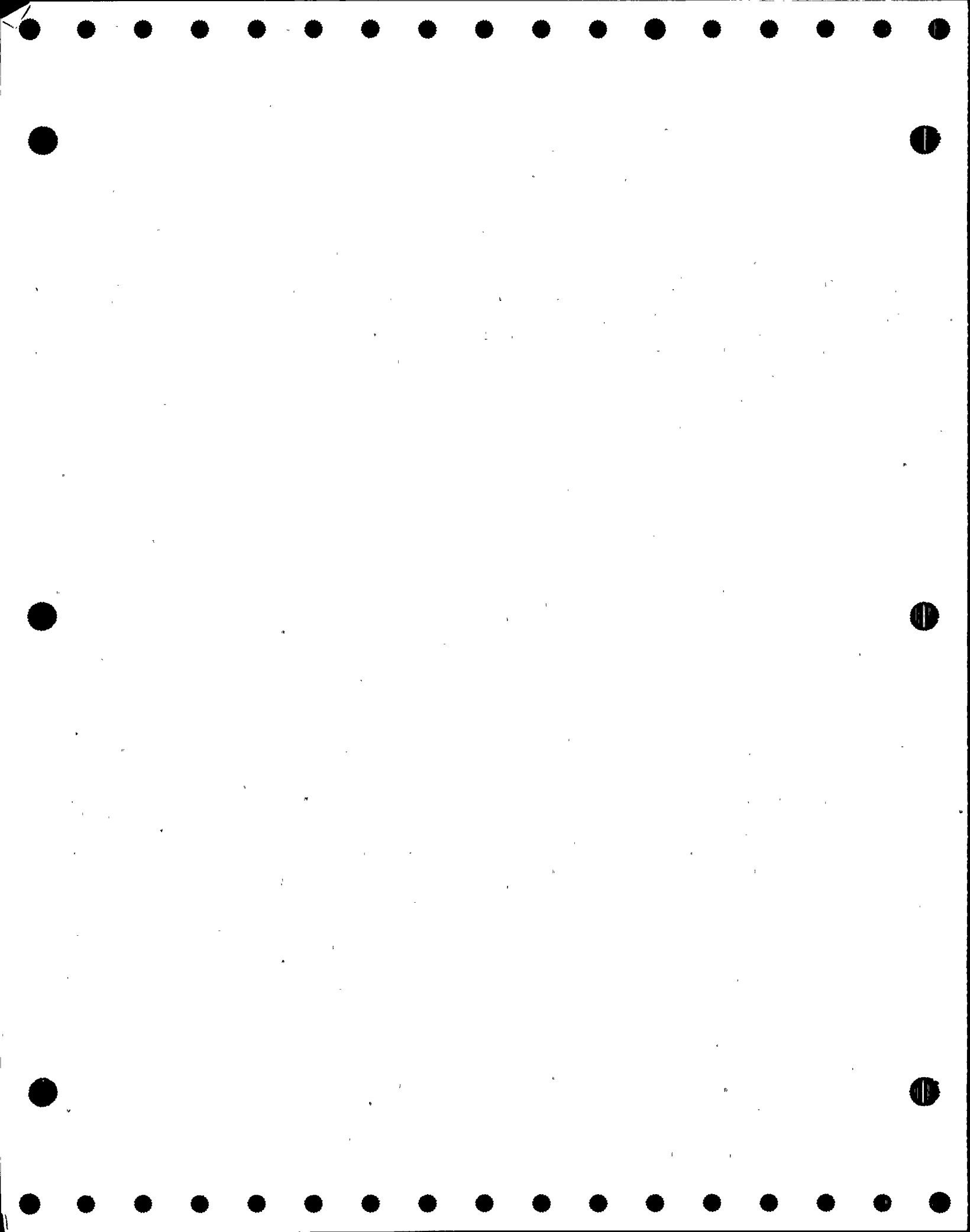

DONALD C. COOK NUCLEAR PLANT
 SECOND TEN YEAR INTERVAL
 VALVE SUMMARY SHEET - UNIT 1
 FLOW DIAGRAM: 1-5141-29

RUN DATE AND TIME: 15FEB90:16:03

SYSTEM NAME: NUCLEAR SAMPLING

VALVE				VALVE POSITION				ASME SECTION XI						
NUMBER	REV	TYPE	SIZE	ACT TYPE	F.D. COORD	POWER OPER	SAFETY FUNCT	CD ICL	A/P	CAT	PRIM TEST REQUIRED	TEST PERFORMED	TEST MODE	RELIEF REQUEST(S)
1-ICR-5	3	GL	0.5	A	C/5	O	C	2	A	A	EF-1	EF-1	P	NO
											EF-5	EF-5	-	NO
											EF-7	EF-7	P	NO
											ET-XXX	ET-XXX	P	NO
											SLT-1	SLT-2	R	YES, NOTE 1
1-ICR-6	3	GL	0.5	A	D/5	O	C	2	A	A	EF-1	EF-1	P	NO
											EF-5	EF-5	-	NO
											EF-7	EF-7	P	NO
											ET-XXX	ET-XXX	P	NO
											SLT-1	SLT-2	R	YES, NOTE 1
1-NCR-105	3	GL	0.5	A	C/7	O	C	2	A	A	EF-1	EF-1	P	NO
											EF-5	EF-5	-	NO
											EF-7	EF-7	P	NO
											ET-XXX	ET-XXX	P	NO
											SLT-1	SLT-2	R	YES, NOTE 1
1-NCR-106	3	GL	0.5	A	C/7	O	C	2	A	A	EF-1	EF-1	P	NO
											EF-5	EF-5	-	NO
											EF-7	EF-7	P	NO
											ET-XXX	ET-XXX	P	NO
											SLT-1	SLT-2	R	YES, NOTE 1
1-NCR-107	3	GL	0.5	A	D/6	O	C	2	A	A	EF-1	EF-1	P	NO
											EF-5	EF-5	-	NO
											EF-7	EF-7	P	NO
											ET-XXX	ET-XXX	P	NO
											SLT-1	SLT-2	R	YES, NOTE 1

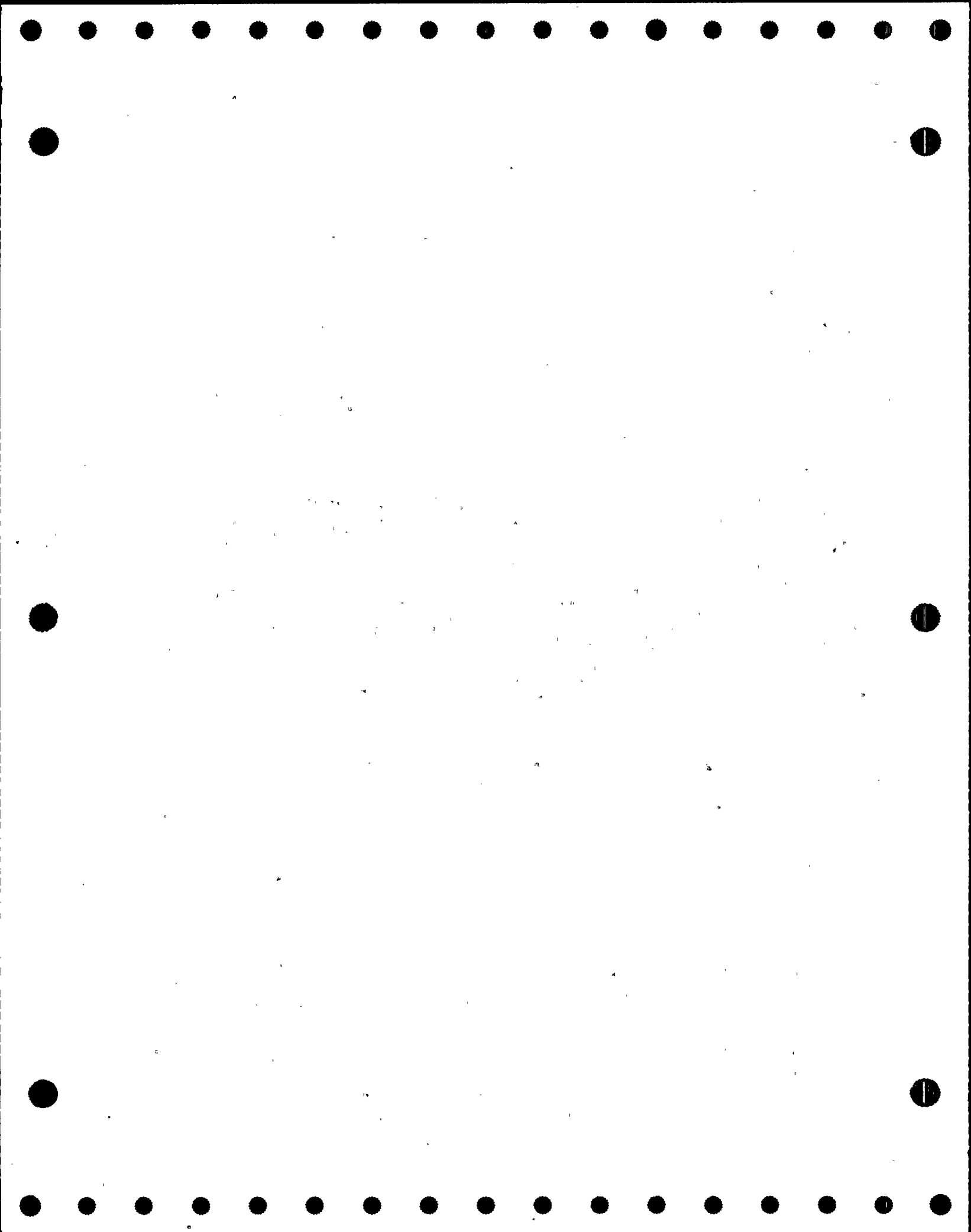

DONALD C. COOK NUCLEAR PLANT
 SECOND TEN YEAR INTERVAL
 VALVE SUMMARY SHEET - UNIT 1
 FLOW DIAGRAM: 1-5141-29

RUN DATE AND TIME: 15FEB90:16:03

SYSTEM NAME: NUCLEAR SAMPLING

VALVE				VALVE POSITION				ASME SECTION XI						
NUMBER	REV	TYPE	SIZE	ACT TYPE	F.D. COORD	POWER OPER	SAFETY FUNCT	CD ICL	A/P	CAT	PRIM TEST REQUIRED	TEST PERFORMED	TEST MODE	RELIEF REQUEST(S)
1-NCR-108	3	GL	0.5	A	D/6	O	C	2	A	A	EF-1	EF-1	P	NO
											EF-5	EF-5	-	NO
											EF-7	EF-7	P	NO
											ET-XXX	ET-XXX	P	NO
											SLT-1	SLT-2	R	YES, NOTE 1
1-NCR-109	3	GL	0.5	A	D/6	O	C	2	A	A	EF-1	EF-1	P	NO
											EF-5	EF-5	-	NO
											EF-7	EF-7	P	NO
											ET-XXX	ET-XXX	P	NO
											SLT-1	SLT-2	R	YES, NOTE 1
1-NCR-110	3	GL	0.5	A	D/6	O	C	2	A	A	EF-1	EF-1	P	NO
											EF-5	EF-5	-	NO
											EF-7	EF-7	P	NO
											ET-XXX	ET-XXX	P	NO
											SLT-1	SLT-2	R	YES, NOTE 1

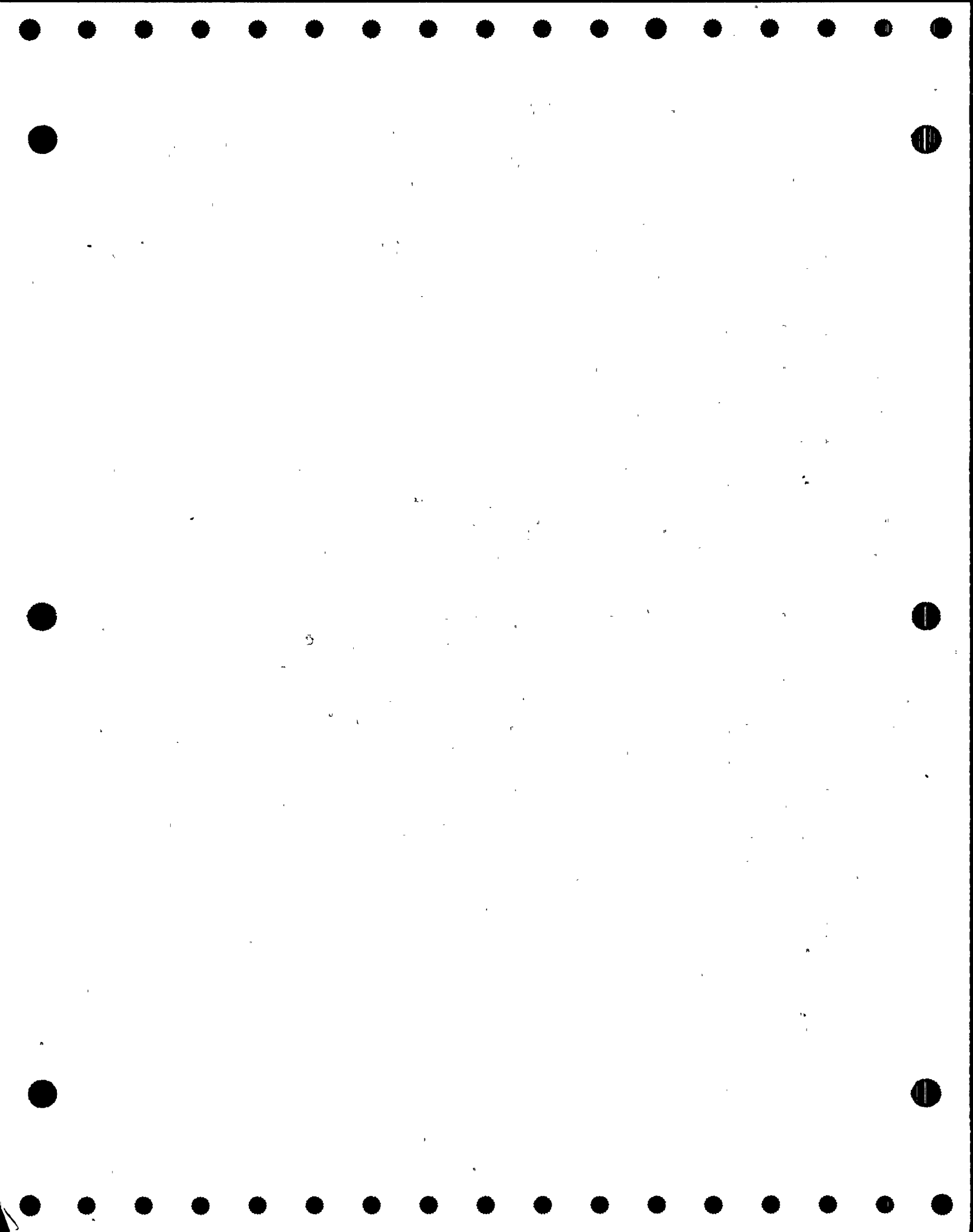

DONALD C. COOK NUCLEAR PLANT
 SECOND TEN YEAR INTERVAL
 VALVE SUMMARY SHEET - UNIT 1
 FLOW DIAGRAM: 1-5141A-32

RUN DATE AND TIME: 15FEB90:16:03

SYSTEM NAME: NUCLEAR SAMPLING

VALVE				VALVE POSITION				ASME SECTION XI						
NUMBER	REV	TYPE	SIZE	ACT TYPE	F.D. COORD	POWER OPER	SAFETY FUNCT	CD ICL	A/P	CAT	PRIM TEST REQUIRED	TEST PERFORMED	TEST MODE	RELIEF REQUEST(S)
1-DCR-301	3	GL	0.5	A	B/2	0	C	2	A	B	EF-1	EF-1	P	NO
											EF-5	EF-5	-	NO
											EF-7	EF-7	P	NO
											ET-XXX	ET-XXX	P	NO
1-DCR-302	3	GL	0.5	A	B/3	0	C	2	A	B	EF-1	EF-1	P	NO
											EF-5	EF-5	-	NO
											EF-7	EF-7	P	NO
											ET-XXX	ET-XXX	P	NO
1-DCR-303	3	GL	0.5	A	B/3	0	C	2	A	B	EF-1	EF-1	P	NO
											EF-5	EF-5	-	NO
											EF-7	EF-7	P	NO
											ET-XXX	ET-XXX	P	NO
1-DCR-304	3	GL	0.5	A	B/3	0	C	2	A	B	EF-1	EF-1	P	NO
											EF-5	EF-5	-	NO
											EF-7	EF-7	P	NO
											ET-XXX	ET-XXX	P	NO
1-MCR-251	3	GL	0.5	A	B/2	0	C	2	A	B	EF-1	EF-1	P	NO
											EF-5	EF-5	-	NO
											EF-7	EF-7	P	NO
											ET-XXX	ET-XXX	P	NO
1-MCR-252	3	GL	0.5	A	B/2	0	C	2	A	B	EF-1	EF-1	P	NO
											EF-5	EF-5	-	NO
											EF-7	EF-7	P	NO
											ET-XXX	ET-XXX	P	NO

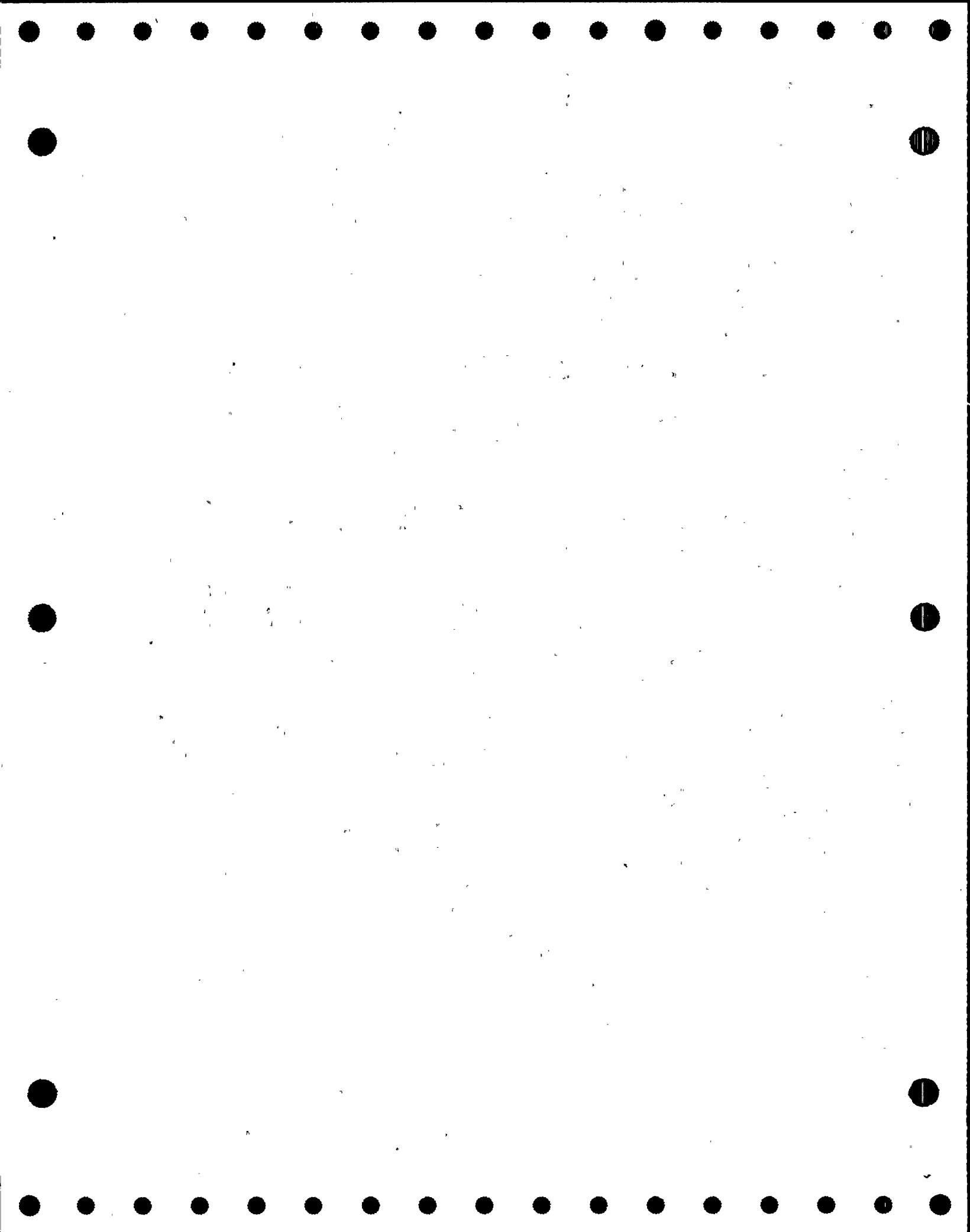

DONALD C. COOK NUCLEAR PLANT
 SECOND TEN YEAR INTERVAL
 VALVE SUMMARY SHEET - UNIT 1
 FLOW DIAGRAM: 1-5141A-32

RUN DATE AND TIME: 15FEB90:16:03

SYSTEM NAME: NUCLEAR SAMPLING

VALVE				VALVE POSITION				ASME SECTION XI						
NUMBER	REV	TYPE	SIZE	ACT TYPE	F.D. COORD	POWER OPER	SAFETY FUNCT	CD ICL	A/P	CAT	PRIM TEST REQUIRED	TEST PERFORMED	TEST MODE	RELIEF REQUEST(S)
1-MCR-253	3	GL	0.5	A	B/1	O	C	2	A	B	EF-1	EF-1	P	NO
											EF-5	EF-5	-	NO
											EF-7	EF-7	P	NO
											ET-XXX	ET-XXX	P	NO
1-MCR-254	3	GL	0.5	A	B/1	O	C	2	A	B	EF-1	EF-1	P	NO
											EF-5	EF-5	-	NO
											EF-7	EF-7	P	NO
											ET-XXX	ET-XXX	P	NO

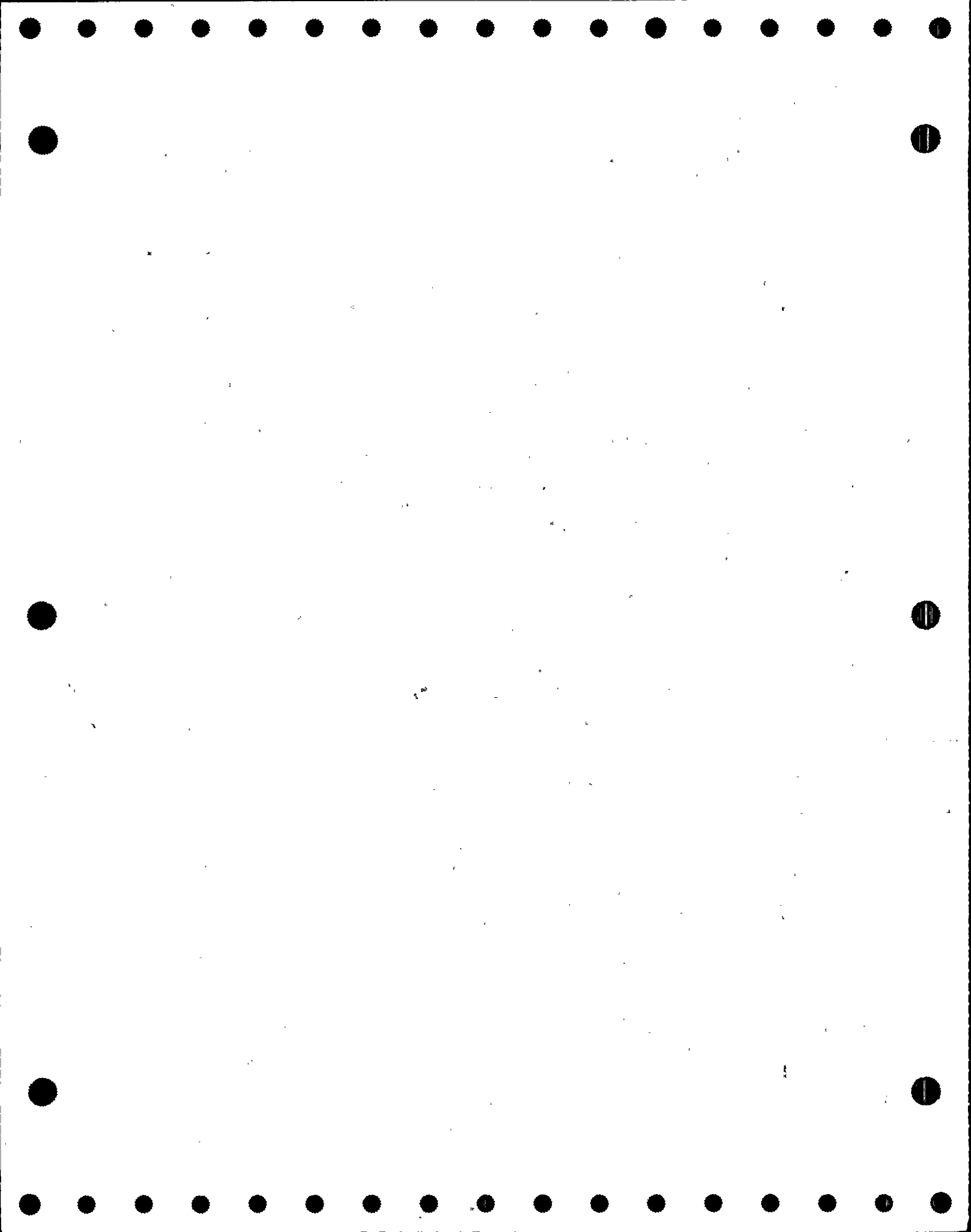

DONALD C. COOK NUCLEAR PLANT
 SECOND TEN YEAR INTERVAL
 VALVE SUMMARY SHEET - UNIT 1
 FLOW DIAGRAM: 1-5141D-10

RUN DATE AND TIME: 15FEB90:16:03

SYSTEM NAME: PAS CONTAINMENT HYDROGEN

VALVE				VALVE POSITION				ASME SECTION XI						
NUMBER	REV	TYPE	SIZE	ACT TYPE	F.D. COORD	POWER OPER	SAFETY FUNCT	CD ICL	A/P	CAT	PRIM TEST REQUIRED	TEST PERFORMED	TEST MODE	RELIEF REQUEST(S)
1-ECR-10	3	GL	0.5	A	C/8	C	O/C	2	A	A	EF-1	EF-1	P	NO
											EF-5	EF-5	-	NO
											EF-7	EF-7	P	NO
											ET-XXX	ET-XXX	P	NO
											SLT-1	SLT-2	R	YES, NOTE 1
1-ECR-11	3	GL	0.5	A	A/2	C	O/C	2	A	A	EF-1	EF-1	P	NO
											EF-5	EF-5	-	NO
											EF-7	EF-7	P	NO
											ET-XXX	ET-XXX	P	NO
											SLT-1	SLT-2	R	YES, NOTE 1
1-ECR-12	3	GL	0.5	A	A/2	C	O/C	2	A	A	EF-1	EF-1	P	NO
											EF-5	EF-5	-	NO
											EF-7	EF-7	P	NO
											ET-XXX	ET-XXX	P	NO
											SLT-1	SLT-2	R	YES, NOTE 1
1-ECR-13	3	GL	0.5	A	A/1	C	O/C	2	A	A	EF-1	EF-1	P	NO
											EF-5	EF-5	-	NO
											EF-7	EF-7	P	NO
											ET-XXX	ET-XXX	P	NO
											SLT-1	SLT-2	R	YES, NOTE 1
1-ECR-14	3	GL	0.5	A	A/3	C	O/C	2	A	A	EF-1	EF-1	P	NO
											EF-5	EF-5	-	NO
											EF-7	EF-7	P	NO
											ET-XXX	ET-XXX	P	NO
											SLT-1	SLT-2	R	YES, NOTE 1

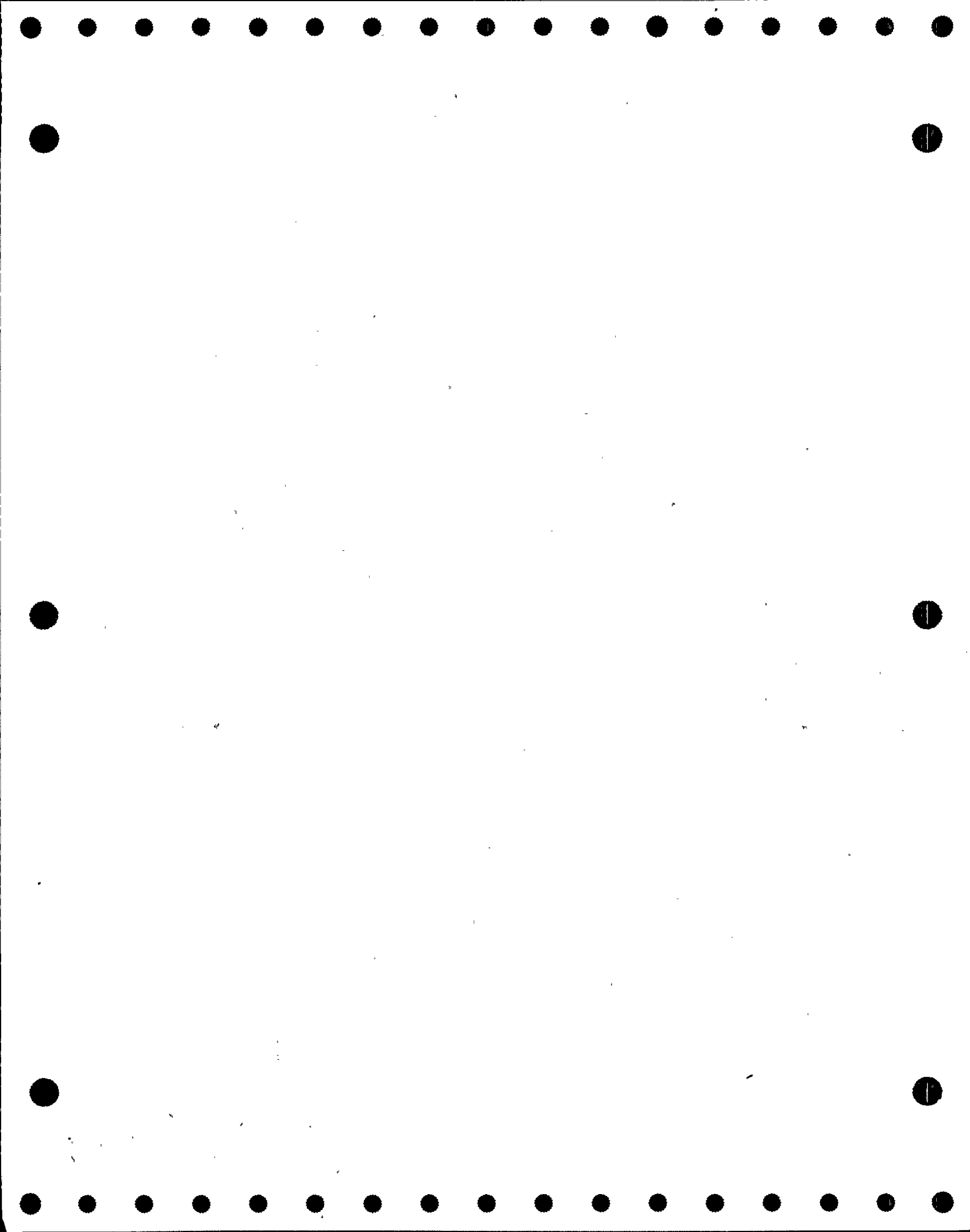

DONALD C. COOK NUCLEAR PLANT
 SECOND TEN YEAR INTERVAL
 VALVE SUMMARY SHEET - UNIT 1
 FLOW DIAGRAM: 1-5141D-10

RUN DATE AND TIME: 15FEB90:16:03

SYSTEM NAME: PAS CONTAINMENT HYDROGEN

VALVE				VALVE POSITION				ASME SECTION XI						
NUMBER	REV	TYPE	SIZE	ACT TYPE	F.D. COORD	POWER OPER	SAFETY FUNCT	CD ICL	A/P	CAT	PRIM TEST REQUIRED	TEST PERFORMED	TEST MODE	RELIEF REQUEST(S)
1-ECR-15	3	GL	0.5	A	A/1	C	O/C	2	A	A	EF-1	EF-1	P	NO
											EF-5	EF-5	-	NO
											EF-7	EF-7	P	NO
											ET-XXX	ET-XXX	P	NO
											SLT-1	SLT-2	R	YES, NOTE 1
1-ECR-16	3	GL	0.5	A	A/3	C	O/C	2	A	A	EF-1	EF-1	P	NO
											EF-5	EF-5	-	NO
											EF-7	EF-7	P	NO
											ET-XXX	ET-XXX	P	NO
											SLT-1	SLT-2	R	YES, NOTE 1
1-ECR-17	3	GL	0.5	A	A/3	C	O/C	2	A	A	EF-1	EF-1	P	NO
											EF-5	EF-5	-	NO
											EF-7	EF-7	P	NO
											ET-XXX	ET-XXX	P	NO
											SLT-1	SLT-2	R	YES, NOTE 1
1-ECR-18	3	GL	0.5	A	A/4	C	O/C	2	A	A	EF-1	EF-1	P	NO
											EF-5	EF-5	-	NO
											EF-7	EF-7	P	NO
											ET-XXX	ET-XXX	P	NO
											SLT-1	SLT-2	R	YES, NOTE 1
1-ECR-19	3	GL	0.5	A	A/4	C	O/C	2	A	A	EF-1	EF-1	P	NO
											EF-5	EF-5	-	NO
											EF-7	EF-7	P	NO
											ET-XXX	ET-XXX	P	NO
											SLT-1	SLT-2	R	YES, NOTE 1

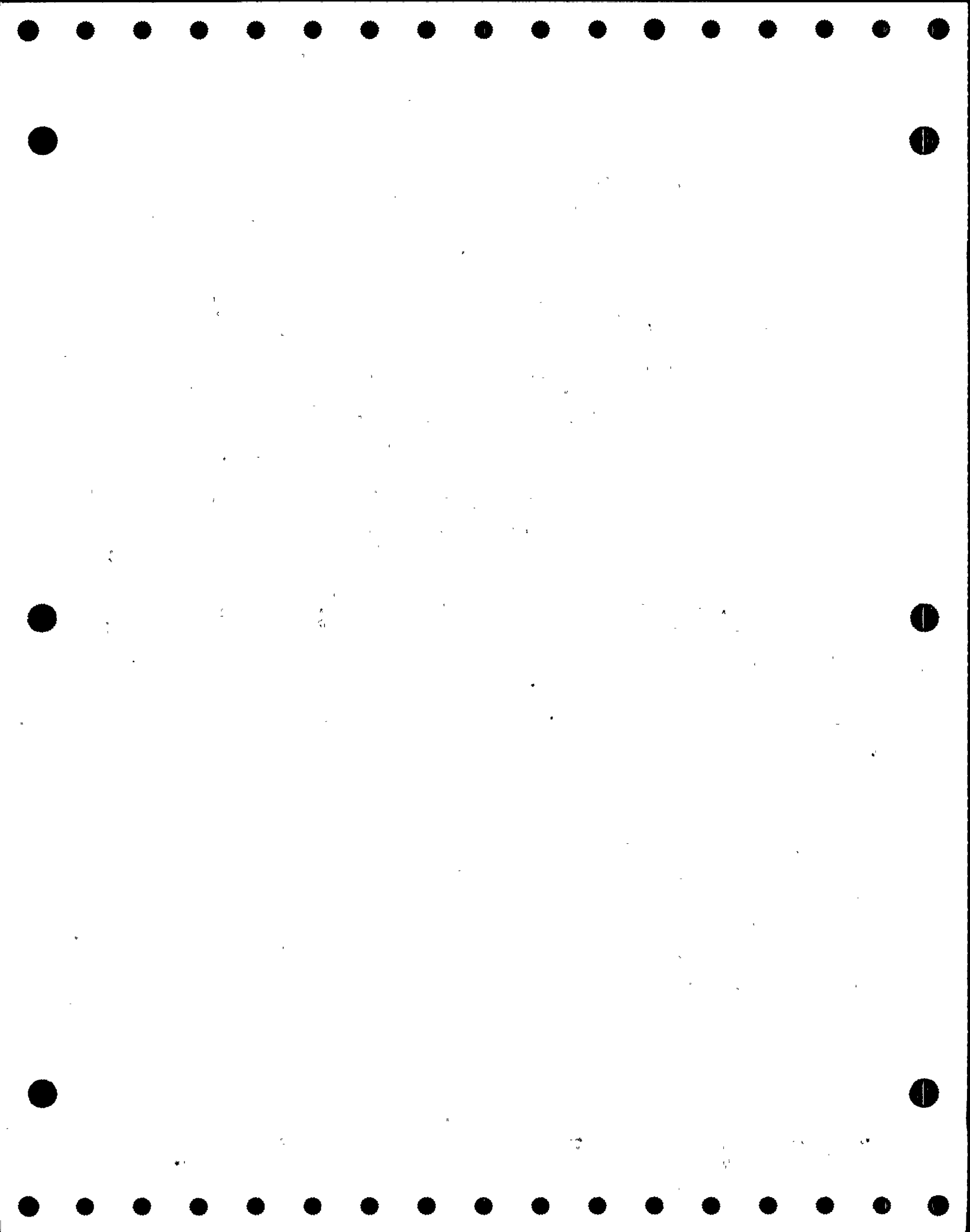

DONALD C. COOK NUCLEAR PLANT
 SECOND TEN YEAR INTERVAL
 VALVE SUMMARY SHEET - UNIT 1
 FLOW DIAGRAM: 1-5141D-10

RUN DATE AND TIME: 15FEB90:16:03

SYSTEM NAME: PAS CONTAINMENT HYDROGEN

VALVE				VALVE POSITION				ASME SECTION XI						
NUMBER	REV	TYPE	SIZE	ACT TYPE	F.D. COORD	POWER OPER	SAFETY FUNCT	CD ICL	A/P	CAT	PRIM TEST REQUIRED	TEST PERFORMED	TEST MODE	RELIEF REQUEST(S)
1-ECR-20	3	GL	0.5	A	C/8	C	O/C	2	A	A	EF-1	EF-1	P	NO
											EF-5	EF-5	-	NO
											EF-7	EF-7	P	NO
											ET-XXX	ET-XXX	P	NO
											SLT-1	SLT-2	R	YES, NOTE 1
1-ECR-21	3	GL	0.5	A	B/2	C	O/C	2	A	A	EF-1	EF-1	P	NO
											EF-5	EF-5	-	NO
											EF-7	EF-7	P	NO
											ET-XXX	ET-XXX	P	NO
											SLT-1	SLT-2	R	YES, NOTE 1
1-ECR-22	3	GL	0.5	A	B/2	C	O/C	2	A	A	EF-1	EF-1	P	NO
											EF-5	EF-5	-	NO
											EF-7	EF-7	P	NO
											ET-XXX	ET-XXX	P	NO
											SLT-1	SLT-2	R	YES, NOTE 1
1-ECR-23	3	GL	0.5	A	B/1	C	O/C	2	A	A	EF-1	EF-1	P	NO
											EF-5	EF-5	-	NO
											EF-7	EF-7	P	NO
											ET-XXX	ET-XXX	P	NO
											SLT-1	SLT-2	R	YES, NOTE 1
1-ECR-24	3	GL	0.5	A	B/3	C	O/C	2	A	A	EF-1	EF-1	P	NO
											EF-5	EF-5	-	NO
											EF-7	EF-7	P	NO
											ET-XXX	ET-XXX	P	NO
											SLT-1	SLT-2	R	YES, NOTE 1

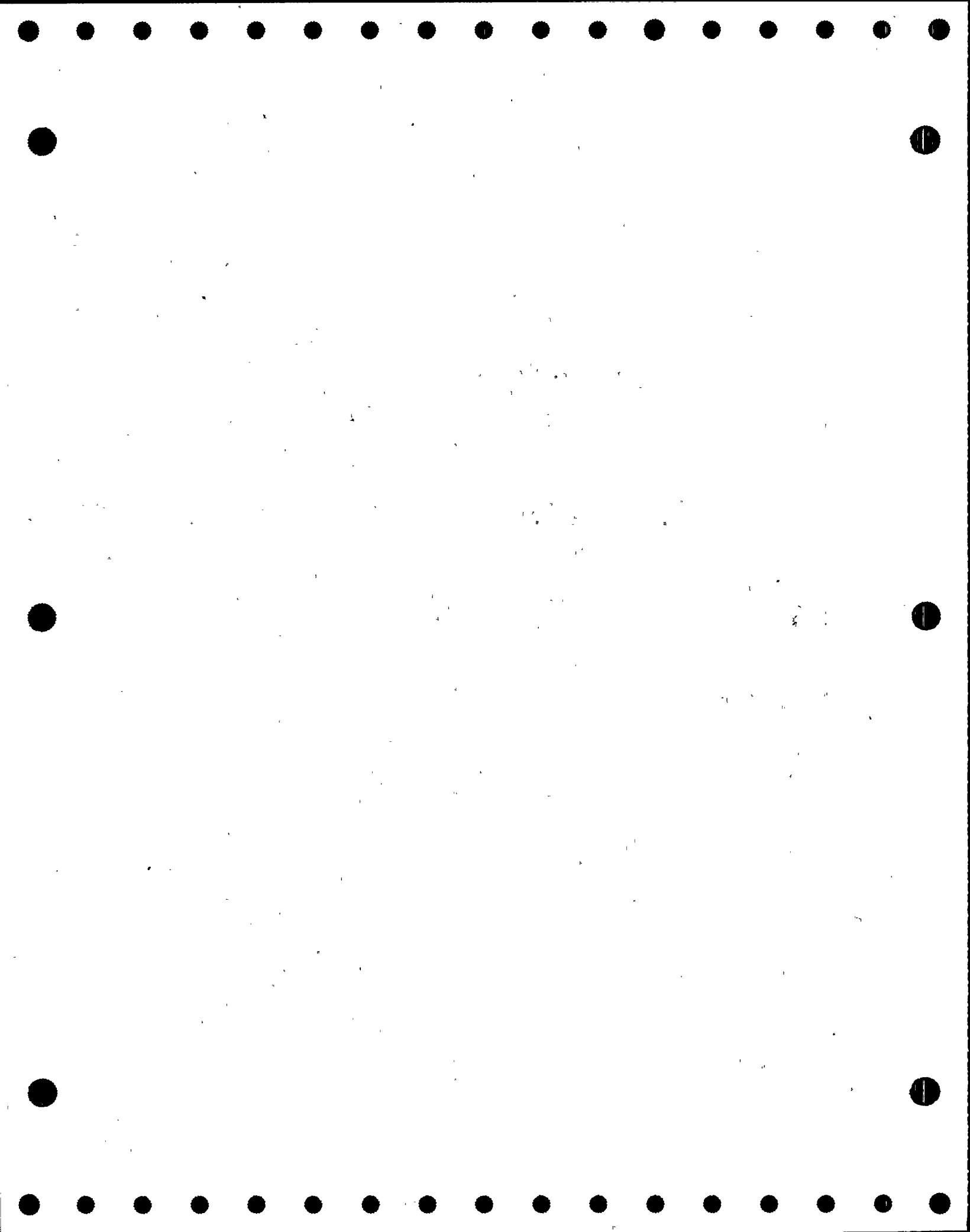

DONALD C. COOK NUCLEAR PLANT
 SECOND TEN YEAR INTERVAL
 VALVE SUMMARY SHEET - UNIT 1
 FLOW DIAGRAM: 1-5141D-10

RUN DATE AND TIME: 15FEB90:16:03

SYSTEM NAME: PAS CONTAINMENT HYDROGEN

VALVE				VALVE POSITION				ASME SECTION XI						
NUMBER	REV	TYPE	SIZE	ACT TYPE	F.D. COORD	POWER OPER	SAFETY FUNCT	CD ICL	A/P	CAT	PRIM TEST REQUIRED	TEST PERFORMED	TEST MODE	RELIEF REQUEST(S)
1-ECR-25	3	GL	0.5	A	B/1	C	O/C	2	A	A	EF-1	EF-1	P	NO
											EF-5	EF-5	-	NO
											EF-7	EF-7	P	NO
											ET-XXX	ET-XXX	P	NO
											SLT-1	SLT-2	R	YES, NOTE 1
1-ECR-26	3	GL	0.5	A	B/3	C	O/C	2	A	A	EF-1	EF-1	P	NO
											EF-5	EF-5	-	NO
											EF-7	EF-7	P	NO
											ET-XXX	ET-XXX	P	NO
											SLT-1	SLT-2	R	YES, NOTE 1
1-ECR-27	3	GL	0.5	A	B/3	C	O/C	2	A	A	EF-1	EF-1	P	NO
											EF-5	EF-5	-	NO
											EF-7	EF-7	P	NO
											ET-XXX	ET-XXX	P	NO
											SLT-1	SLT-2	R	YES, NOTE 1
1-ECR-28	3	GL	0.5	A	B/4	C	O/C	2	A	A	EF-1	EF-1	P	NO
											EF-5	EF-5	-	NO
											EF-7	EF-7	P	NO
											ET-XXX	ET-XXX	P	NO
											SLT-1	SLT-2	R	YES, NOTE 1
1-ECR-29	3	GL	0.5	A	B/4	C	O/C	2	A	A	EF-1	EF-1	P	NO
											EF-5	EF-5	-	NO
											EF-7	EF-7	P	NO
											ET-XXX	ET-XXX	P	NO
											SLT-1	SLT-2	R	YES, NOTE 1

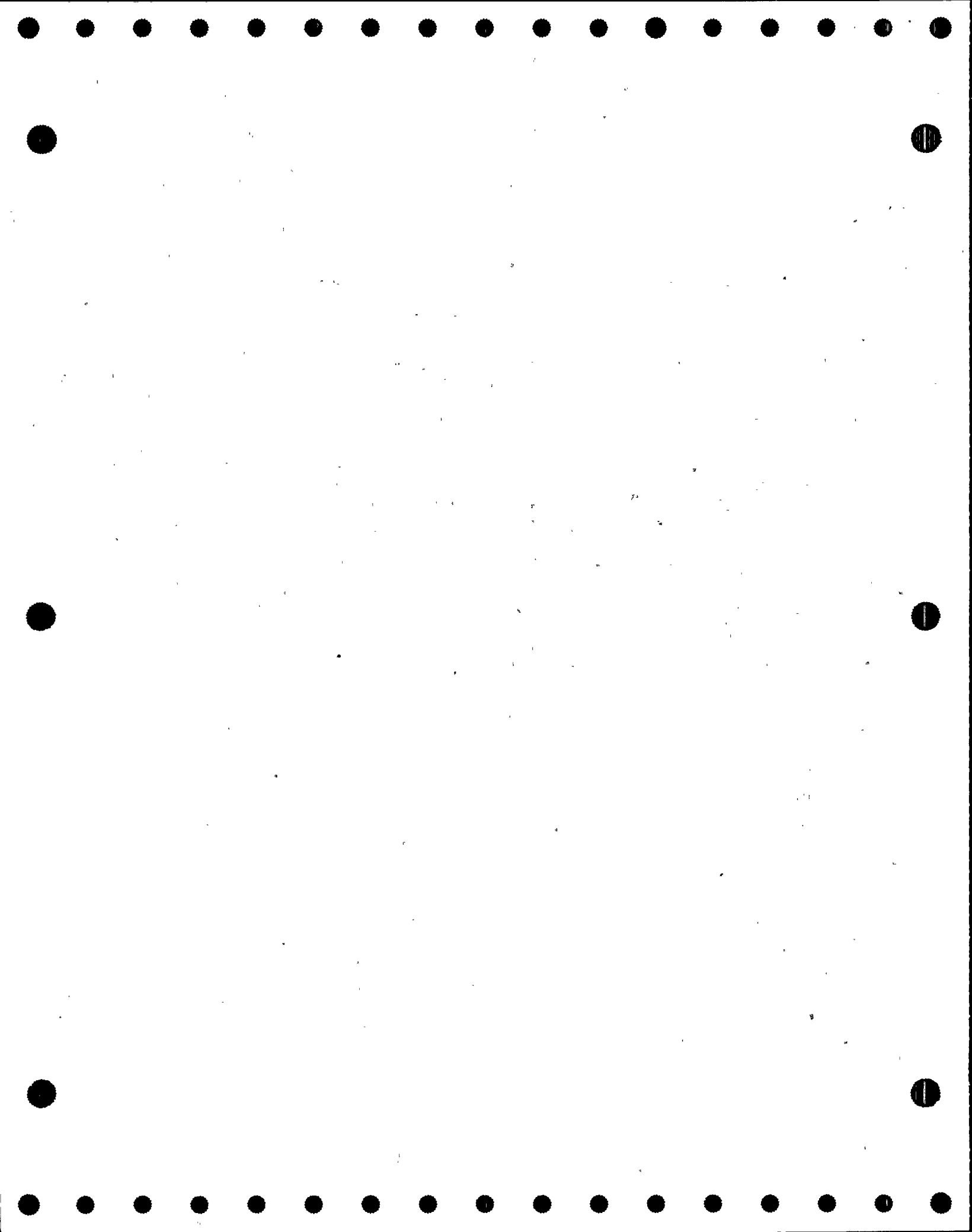

DONALD C. COOK NUCLEAR PLANT
 SECOND TEN YEAR INTERVAL
 VALVE SUMMARY SHEET - UNIT 1
 FLOW DIAGRAM: 1-5141D-10

RUN DATE AND TIME: 15FEB90:16:03

SYSTEM NAME: PAS CONTAINMENT HYDROGEN

VALVE				VALVE POSITION				ASME SECTION XI						
NUMBER	REV	TYPE	SIZE	ACT TYPE	F.D. COORD	POWER OPER	SAFETY FUNCT	CD ICL	A/P	CAT	PRIM TEST REQUIRED	TEST PERFORMED	TEST MODE	RELIEF REQUEST(S)
1-NS-283	3	CK	0.5	SA	C/8	C	O/C	2	A	AC	CF-1 SLT-1	CF-2 SLT-2	R R	YES, NOTE 2 YES, NOTE 1

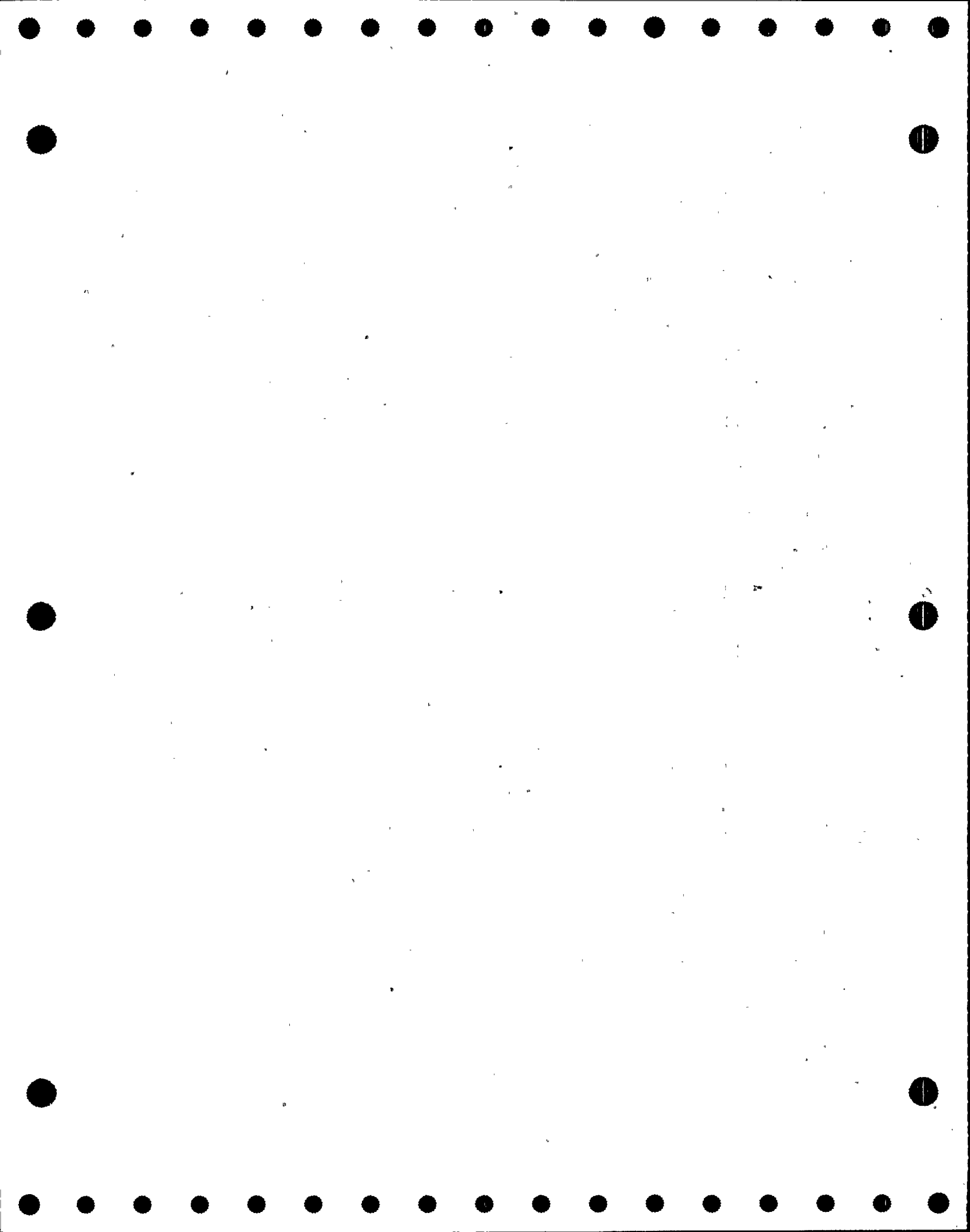

DONALD C. COOK NUCLEAR PLANT
 SECOND TEN YEAR INTERVAL
 VALVE SUMMARY SHEET - UNIT 1
 FLOW DIAGRAM: 1-5142-25

RUN DATE AND TIME: 15FEB90:16:03

SYSTEM NAME: EMERGENCY CORE COOLING - SIS

VALVE				VALVE POSITION				ASME SECTION XI						
NUMBER	REV	TYPE	SIZE	ACT TYPE	F.D. COORD	POWER OPER	SAFETY FUNCT	CD ICL	A/P	CAT	PRIM TEST REQUIRED	TEST PERFORMED	TEST MODE	RELIEF REQUEST(S)
1-ICM-250	3	GA	4	MO	H/2	C	O/C	2	A	A	EF-1 EF-5 ET-XXX SLT-1	EF-2 EF-5 ET-XXX SLT-2	C - C R	NO, CSJ 1 NO NO, CSJ 1 YES, NOTE 2
1-ICM-251	3	GA	4	MO	H/3	C	O/C	2	A	A	EF-1 EF-5 ET-XXX SLT-1	EF-2 EF-5 ET-XXX SLT-2	C - C R	NO, CSJ 1 NO NO, CSJ 1 YES, NOTE 2
1-ICM-260	3	GA	4	MO	C/9	O	O/C	2	A	A	EF-1 EF-5 ET-XXX SLT-1	EF-1 EF-5 ET-XXX SLT-2	P - P R	NO NO NO YES, NOTE 2
1-ICM-265	3	GA	4	MO	C/8	O	O/C	2	A	A	EF-1 EF-5 ET-XXX SLT-1	EF-1 EF-5 ET-XXX SLT-2	P - P R	NO NO NO YES, NOTE 2
1-IMO-255	3	GA	4	MO	J/7	C	O	2	A	B	EF-1 EF-5 ET-XXX	EF-1 EF-5 ET-XXX	P - P	NO NO NO
1-IMO-256	3	GA	4	MO	J/6	C	O	2	A	B	EF-1 EF-5 ET-XXX	EF-1 EF-5 ET-XXX	P - P	NO NO NO
1-IMO-261	3	GA	8	MO	H/8	O	O/C	2	A	B	EF-1 EF-5 ET-XXX	EF-2 EF-5 ET-XXX	C - C	NO, CSJ 3 NO NO, CSJ 3

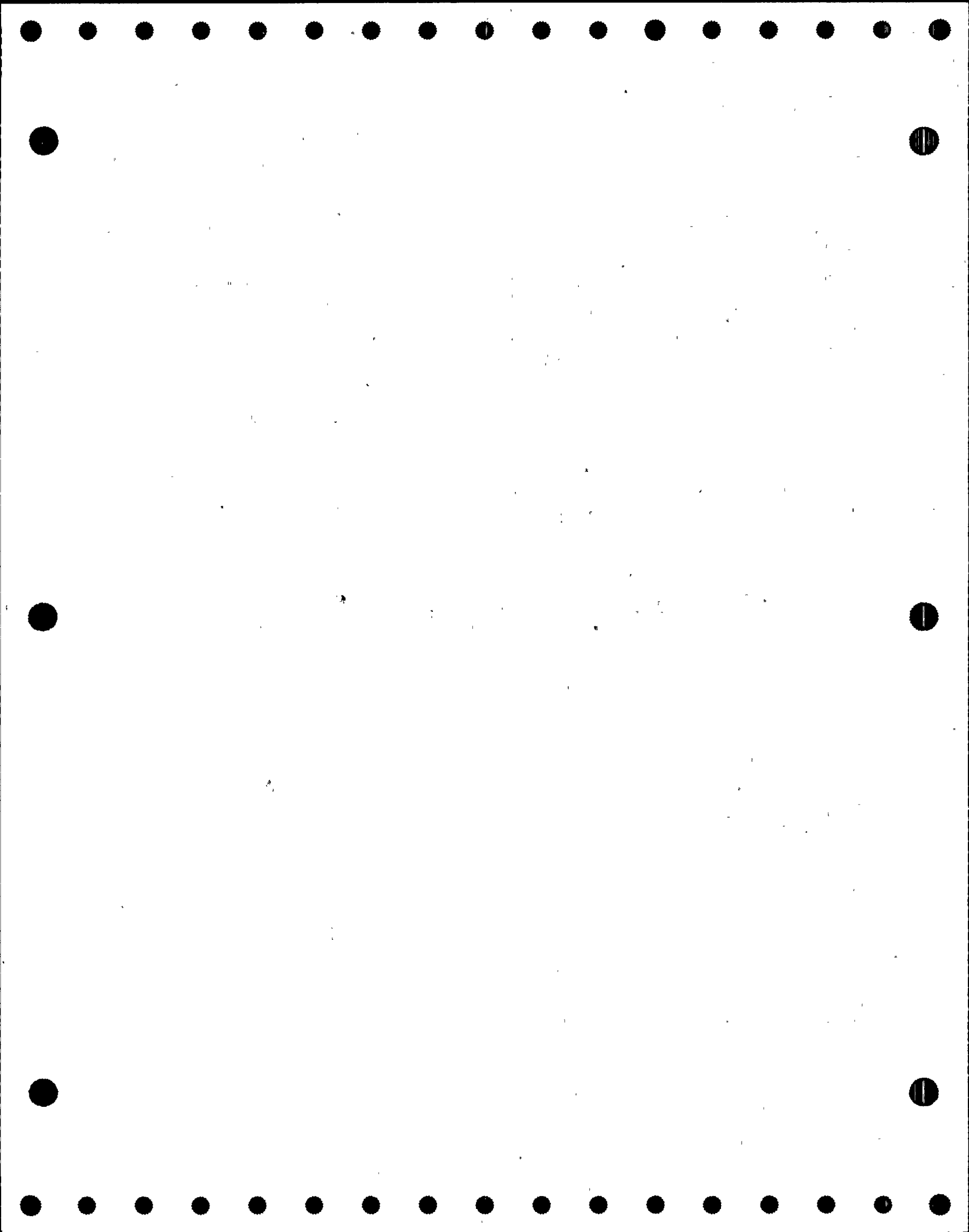

DONALD C. COOK NUCLEAR PLANT
 SECOND TEN YEAR INTERVAL
 VALVE SUMMARY SHEET - UNIT 1
 FLOW DIAGRAM: 1-5142-25

RUN DATE AND TIME: 15FEB90:16:03

SYSTEM NAME: EMERGENCY CORE COOLING - SIS

VALVE				VALVE POSITION				ASME SECTION XI						
NUMBER	REV	TYPE	SIZE	ACT TYPE	F.D. COORD	POWER OPER	SAFETY FUNCT	CD ICL	A/P	CAT	PRIM TEST REQUIRED	TEST PERFORMED	TEST MODE	RELIEF REQUEST(S)
1-IMO-262	3	GL	2	MO	L/8	0	O/C	2	A	B	EF-1 EF-5 ET-XXX	EF-2 EF-5 ET-XXX	C - C	NO, CSJ 4 NO NO, CSJ 4
1-IMO-263	3	GL	2	MO	L/8	0	O/C	2	A	B	EF-1 EF-5 ET-XXX	EF-2 EF-5 ET-XXX	C - C	NO, CSJ 4 NO NO, CSJ 4
1-IMO-270	3	GA	4	MO	E/9	0	O/C	2	A	B	EF-1 EF-5 ET-XXX	EF-1 EF-5 ET-XXX	P - P	NO NO NO
1-IMO-275	3	GA	4	MO	E/8	0	O/C	2	A	B	EF-1 EF-5 ET-XXX	EF-1 EF-5 ET-XXX	P - P	NO NO NO
1-IMO-361	3	GA	4	MO	G/9	C	C/O	2	A	B	EF-1 EF-5 ET-XXX	EF-1 EF-5 ET-XXX	P - P	NO NO NO
1-IMO-362	3	GA	4	MO	G/9	C	C/O	2	A	B	EF-1 EF-5 ET-XXX	EF-1 EF-5 ET-XXX	P - P	NO NO NO
1-IRV-251	3	GL	1	A	H/5	0	C	2	A	B	EF-1 EF-5 EF-7 ET-XXX	EF-1 EF-5 EF-7 ET-XXX	P - P P	NO NO NO NO

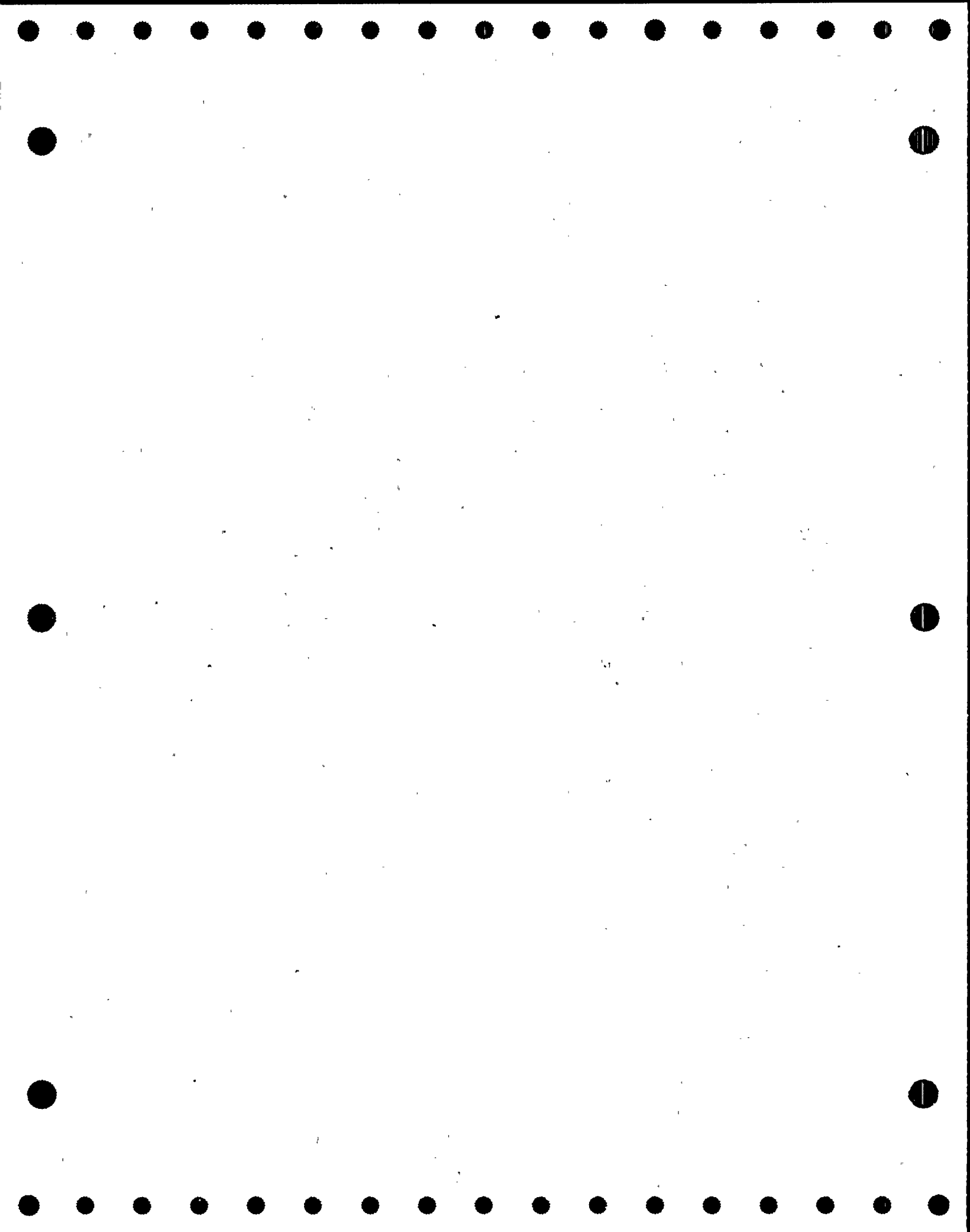

DONALD C. COOK NUCLEAR PLANT
 SECOND TEN YEAR INTERVAL
 VALVE SUMMARY SHEET - UNIT 1
 FLOW DIAGRAM: 1-5142-25

RUN DATE AND TIME: 15FEB90:16:03

SYSTEM NAME: EMERGENCY CORE COOLING - SIS

VALVE				VALVE POSITION				ASME SECTION XI						
NUMBER	REV	TYPE	SIZE	ACT TYPE	F.D. COORD	POWER OPER	SAFETY FUNCT	CD ICL	A/P	CAT	PRIM TEST REQUIRED	TEST PERFORMED	TEST MODE	RELIEF REQUEST(S)
1-IRV-252	3	GL	1	A	J/5	O	C	3	A	B	EF-1 EF-5 EF-7 ET-XXX	EF-1 EF-5 EF-7 ET-XXX	P - P P	NO NO NO NO
1-IRV-255	3	GL	1	A	H/6	O	C	2	A	B	EF-1 EF-5 EF-7 ET-XXX	EF-1 EF-5 EF-7 ET-XXX	P - P P	NO NO NO NO
1-SI-101	3	CK	8	SA	M/8	C	O	2	A	C	CF-1	CF-3	R	YES, NOTE 5
1-SI-104-N	3	CK	0.75	SA	E/9	C	O	2	A	C	CF-1	CF-1	P	NO
1-SI-104-S	3	CK	0.75	SA	J/9	C	O	2	A	C	CF-1	CF-1	P	NO
1-SI-110-N	3	CK	4	SA	E/9	C	O	2	A	C	CF-1	CF-2	R	YES, NOTE 5
1-SI-110-S	3	CK	4	SA	H/9	C	O	2	A	C	CF-1	CF-2	R	YES, NOTE 5
1-SI-126	3	CK	1	SA	H/6	O	C	2	A	C	CF-1	CF-1	P	NO
1-SI-142-L1	3	CK	1.5	SA	C/1	C	O	1	A	C	CF-1	CF-2	R	YES, NOTE 6
1-SI-142-L2	3	CK	1.5	SA	C/2	C	O	1	A	C	CF-1	CF-2	R	YES, NOTE 6

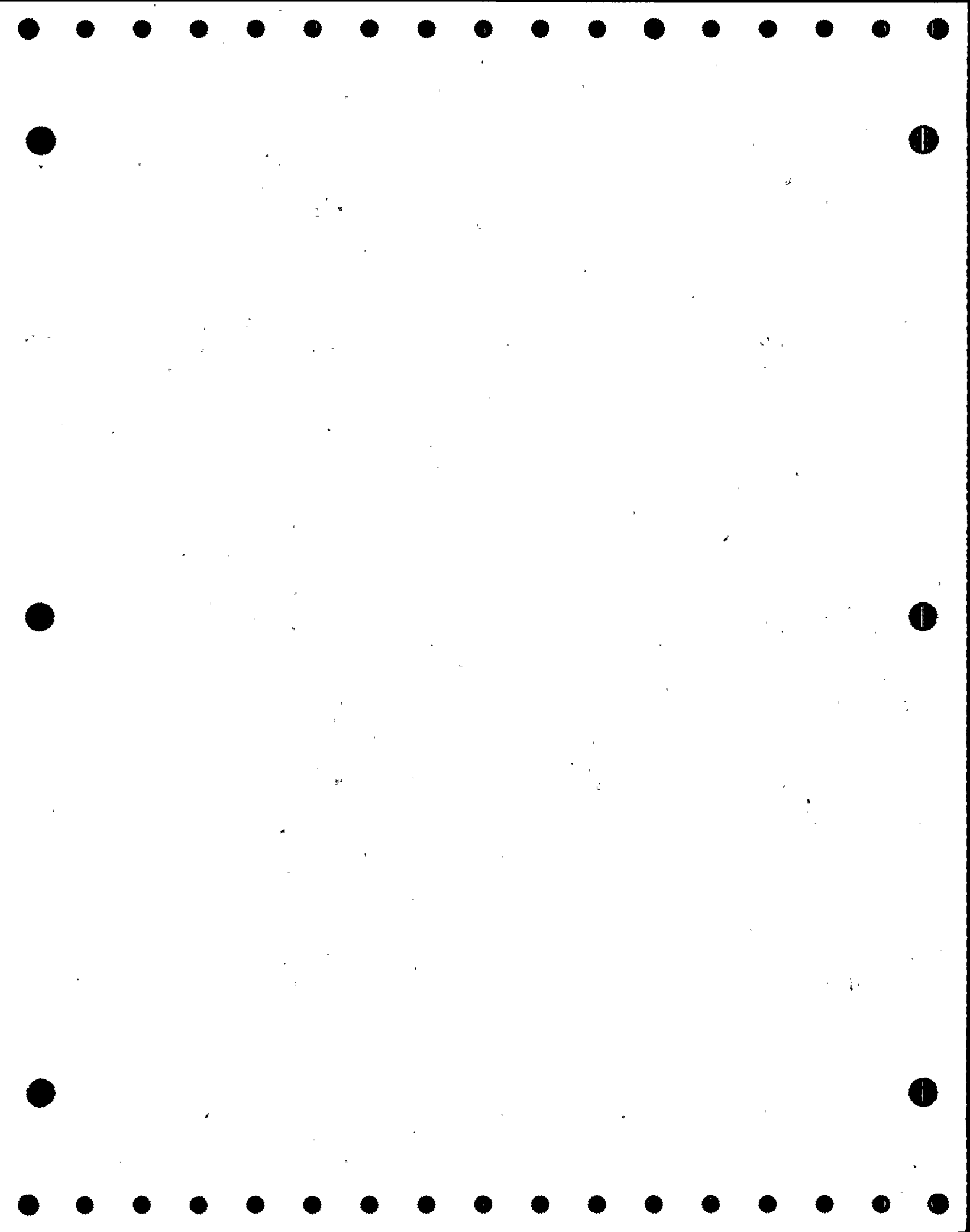

DONALD C. COOK NUCLEAR PLANT
 SECOND TEN YEAR INTERVAL
 VALVE SUMMARY SHEET - UNIT 1
 FLOW DIAGRAM: 1-5142-25

RUN DATE AND TIME: 15FEB90:16:03

SYSTEM NAME: EMERGENCY CORE COOLING - SIS

VALVE				VALVE POSITION				ASME SECTION XI						
NUMBER	REV	TYPE	SIZE	ACT TYPE	F.D. COORD	POWER OPER	SAFETY FUNCT	CD ICL	A/P	CAT	PRIM TEST REQUIRED	TEST PERFORMED	TEST MODE	RELIEF REQUEST(S)
1-SI-142-L3	3	CK	1.5	SA	C/2	C	0	1	A	C	CF-1	CF-2	R	YES, NOTE 6
1-SI-142-L4	3	CK	1.5	SA	C/1	C	0	1	A	C	CF-1	CF-2	R	YES, NOTE 6
1-SV-96	3	REL	0.75	SA	J/8	C	0	2	A	C	TF-1	TF-1	R	NO
1-SV-97	3	REL	0.75	SA	J/4	C	0	2	A	C	TF-1	TF-1	R	NO
1-SV-98-N	3	REL	0.75	SA	C/9	C	0	2	A	C	TF-1	TF-1	R	NO
1-SV-98-S	3	REL	0.75	SA	E/8	C	0	2	A	C	TF-1	TF-1	R	NO

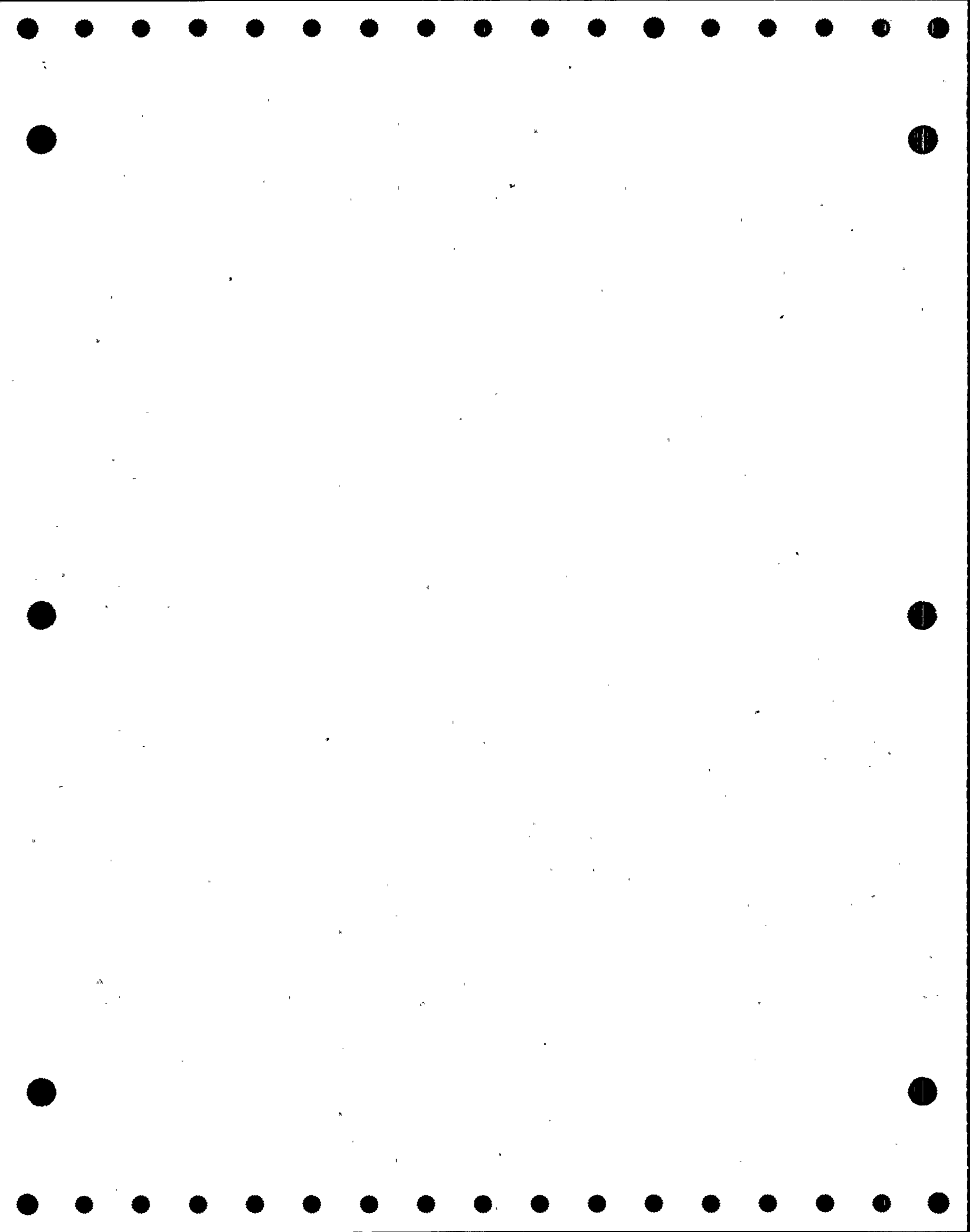

DONALD C. COOK NUCLEAR PLANT
 SECOND TEN YEAR INTERVAL
 VALVE SUMMARY SHEET - UNIT 1
 FLOW DIAGRAM: 1-5143-36

RUN DATE AND TIME: 15FEB90:16:03

SYSTEM NAME: EMERGENCY CORE COOLING - RHR

VALVE				VALVE POSITION				ASME SECTION XI						
NUMBER	REV	TYPE	SIZE	ACT TYPE	F.D. COORD	POWER OPER	SAFETY FUNCT	CD ICL	A/P	CAT	PRIM TEST REQUIRED	TEST PERFORMED	TEST MODE	RELIEF REQUEST(S)
1-GCR-314	3	GL	1	A	G/2	O	C	2	A	A	EF-1	EF-1	P	NO
											EF-5	EF-5	-	NO
											EF-7	EF-7	P	NO
											ET-XXX	ET-XXX	P	NO
											SLT-1	SLT-2	R	YES, NOTE 14
1-ICM-129	3	GA	14	MO	E/8	C	C	1	P	A	EF-1	EF-2	C	NO, CSJ 2
											EF-5	EF-5	-	NO
											ET-XXX	ET-XXX	C	NO, CSJ 2
											SLT-1	SLT-1	R	NO, NOTE 1
											EF-1	EF-1	P	NO
1-ICM-305	3	GA	18	MO	D/9	C	O	2	A	A	EF-5	EF-5	-	NO
											ET-XXX	ET-XXX	P	NO
											SLT-1	SLT-2	R	YES, NOTE 14
											EF-1	EF-1	P	NO
											EF-5	EF-5	-	NO
1-ICM-306	3	GA	18	MO	D/9	C	O	2	A	A	ET-XXX	ET-XXX	P	NO
											SLT-1	SLT-2	R	YES, NOTE 14
											EF-1	EF-1	P	NO
											EF-5	EF-5	-	NO
											ET-XXX	ET-XXX	P	NO
1-IMO-128	3	GA	14	MO	B/8	C	C	1	P	B	SLT-1	SLT-2	R	YES, NOTE 14
											EF-1	EF-2	C	NO, CSJ 2
											EF-5	EF-5	-	NO
											ET-XXX	ET-XXX	C	NO, CSJ 2
											EF-1	EF-1	P	NO
1-IMO-310	3	GA	14	MO	H/9	O	C	2	A	B	EF-5	EF-5	-	NO
											ET-XXX	ET-XXX	P	NO, NOTE 3
											EF-1	EF-1	P	NO
											EF-5	EF-5	-	NO
											ET-XXX	ET-XXX	P	NO, NOTE 3

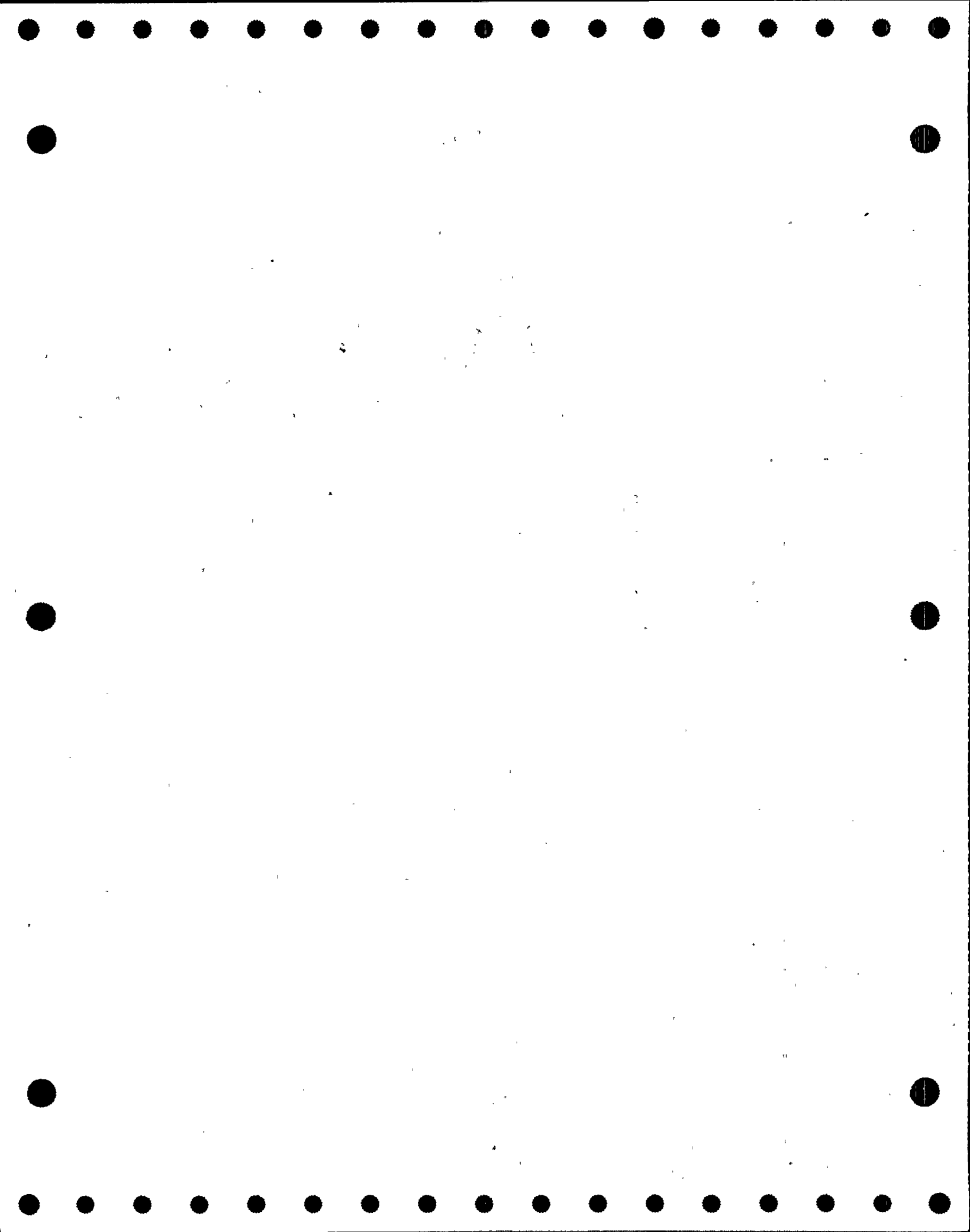

DONALD C. COOK NUCLEAR PLANT
 SECOND TEN YEAR INTERVAL
 VALVE SUMMARY SHEET - UNIT 1
 FLOW DIAGRAM: 1-5143-36

RUN DATE AND TIME: 15FEB90:16:03

SYSTEM NAME: EMERGENCY CORE COOLING - RHR

VALVE				VALVE POSITION				ASME SECTION XI						
NUMBER	REV	TYPE	SIZE	ACT TYPE	F.D. COORD	POWER OPER	SAFETY FUNCT	CD ICL	A/P	CAT	PRIM TEST REQUIRED	TEST PERFORMED	TEST MODE	RELIEF REQUEST(S)
1-IMO-312	3	GL	2	MO	J/5	0	O/C	2	A	B	EF-1 EF-5 ET-XXX	EF-1 EF-5 ET-XXX	P - P	NO NO NO
1-IMO-314	3	GA	8	MO	K/6	0	C	2	A	B	EF-1 EF-5 ET-XXX	EF-1 EF-5 ET-XXX	P - P	NO NO NO, NOTE 3
1-IMO-315	3	GA	8	MO	C/7	C	C/O	1	A	B	EF-1 EF-5 ET-XXX	EF-2 EF-5 ET-XXX	C - C	NO, CSJ 4 NO NO, CSJ 4
1-IMO-316	3	GA	8	MO	C/7	0	O/C	2	A	B	EF-1 EF-5 ET-XXX	EF-2 EF-5 ET-XXX	C - C	NO, CSJ 4 NO NO, CSJ 4
1-IMO-320	3	GA	14	MO	L/9	0	C	2	A	B	EF-1 EF-5 ET-XXX	EF-1 EF-5 ET-XXX	P - P	NO NO NO, NOTE 3
1-IMO-322	3	GL	2	MO	M/5	0	O/C	2	A	B	EF-1 EF-5 ET-XXX	EF-1 EF-5 ET-XXX	P - P	NO NO NO
1-IMO-324	3	GA	8	MO	M/6	0	C	2	A	B	EF-1 EF-5 ET-XXX	EF-1 EF-5 ET-XXX	P - P	NO NO NO, NOTE 3

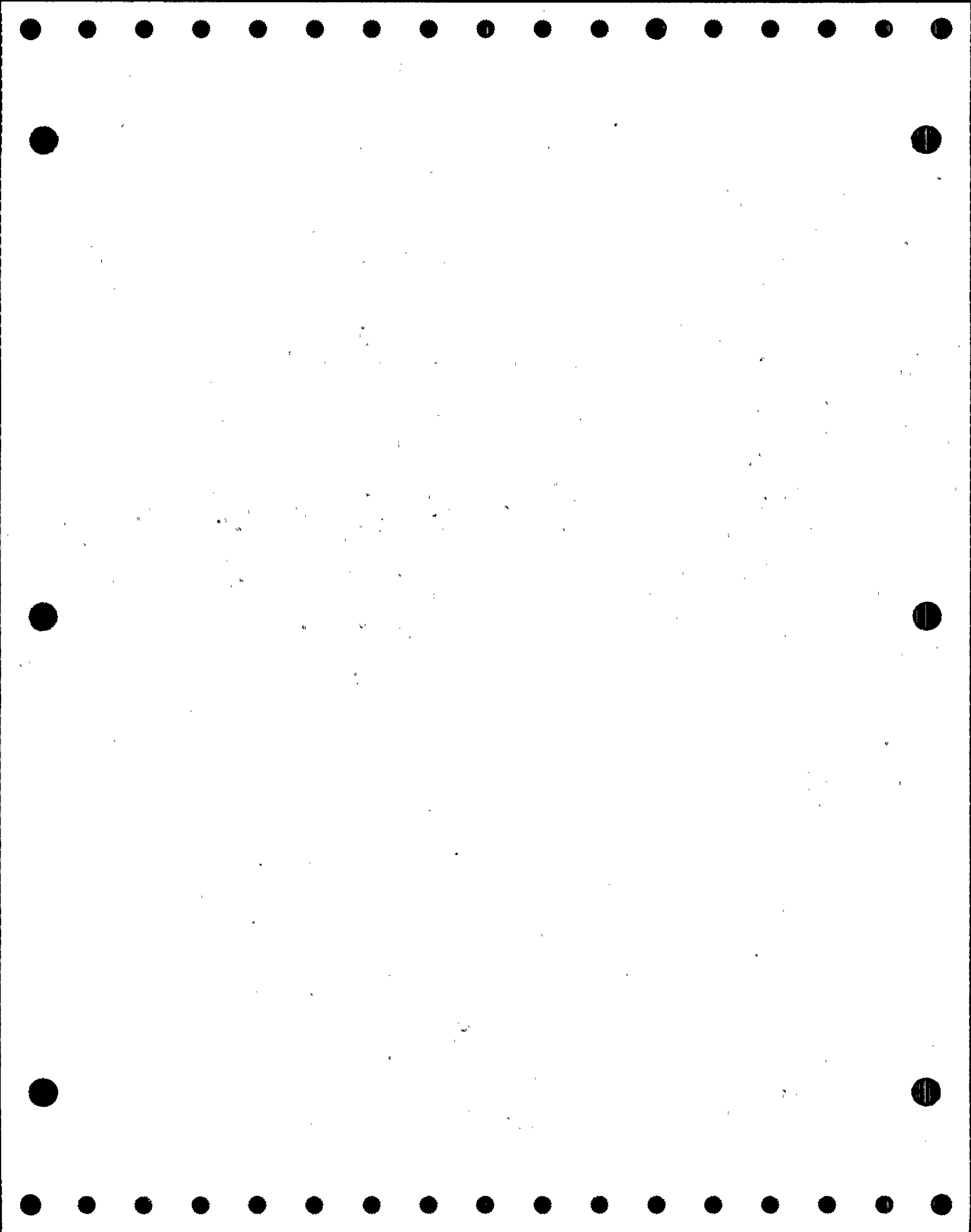

DONALD C. COOK NUCLEAR PLANT
 SECOND TEN YEAR INTERVAL
 VALVE SUMMARY SHEET - UNIT 1
 FLOW DIAGRAM: 1-5143-36

RUN DATE AND TIME: 15FEB90:16:03

SYSTEM NAME: EMERGENCY CORE COOLING - RHR

VALVE				VALVE POSITION				ASME SECTION XI						
NUMBER	REV	TYPE	SIZE	ACT TYPE	F.D. COORD	POWER OPER	SAFETY FUNCT	CD ICL	A/P	CAT	PRIM TEST REQUIRED	TEST PERFORMED	TEST MODE	RELIEF REQUEST(S)
1-IMO-325	3	GA	8	MO	C/7	C	C/O	1	A	B	EF-1 EF-5 ET-XXX	EF-2 EF-5 ET-XXX	C - C	NO, CSJ 4 NO NO, CSJ 4
1-IMO-326	3	GA	8	MO	C/7	O	O/C	2	A	B	EF-1 EF-5 ET-XXX	EF-2 EF-5 ET-XXX	C - C	NO, CSJ 4 NO NO, CSJ 4
1-IMO-330	3	GA	8	MO	G/4	C	O	2	A	B	EF-1 EF-5 ET-XXX	EF-1 EF-5 ET-XXX	P - P	NO NO NO
1-IMO-331	3	GA	8	MO	L/5	C	O	2	A	B	EF-1 EF-5 ET-XXX	EF-1 EF-5 ET-XXX	P - P	NO NO NO
1-IMO-340	3	GA	8	MO	H/5	C	O	2	A	B	EF-1 EF-5 ET-XXX	EF-2 EF-5 ET-XXX	C - C	YES, NOTE 15 NO YES, NOTE 15
1-IMO-350	3	GA	8	MO	L/5	C	O	2	A	B	EF-1 EF-5 ET-XXX	EF-2 EF-5 ET-XXX	C - C	YES, NOTE 15 NO YES, NOTE 15
1-N-102	3	CK	1	SA	F/5	O/C	C	2	A	AC	CF-1 SLT-1	CF-2 SLT-2	R R	YES, NOTE 13 YES, NOTE 14
1-RH-108E	3	CK	8	SA	K/9	C	O	2	A	C	CF-1	CF-3	C	NO, CSJ 7

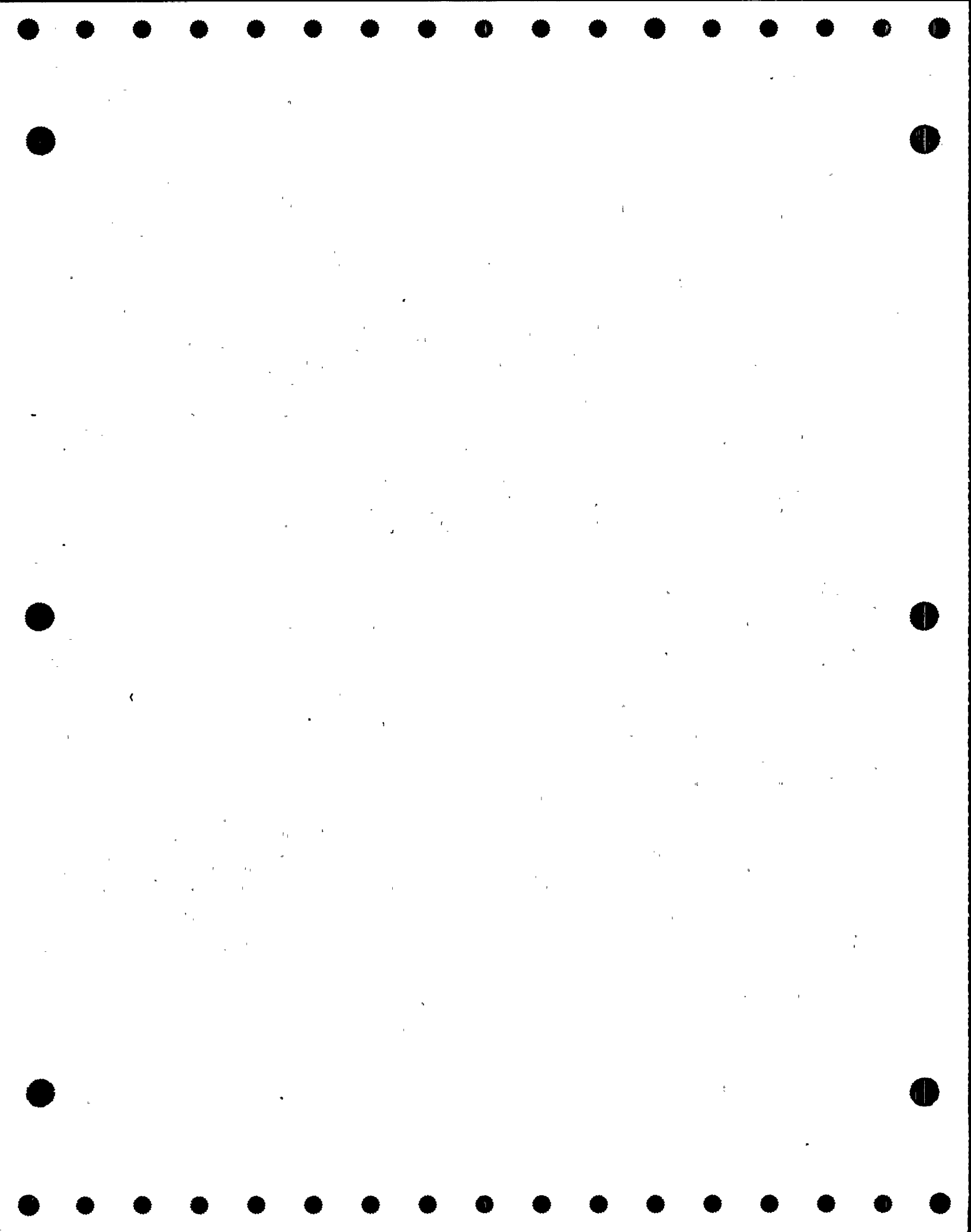

DONALD C. COOK NUCLEAR PLANT
 SECOND TEN YEAR INTERVAL
 VALVE SUMMARY SHEET - UNIT 1
 FLOW DIAGRAM: 1-5143-36

RUN DATE AND TIME: 15FEB90:16:03

SYSTEM NAME: EMERGENCY CORE COOLING - RHR

VALVE				VALVE POSITION				ASME SECTION XI						
NUMBER	REV	TYPE	SIZE	ACT TYPE	F.D. COORD	POWER OPER	SAFETY FUNCT	CD ICL	A/P	CAT	PRIM TEST REQUIRED	TEST PERFORMED	TEST MODE	RELIEF REQUEST(S)
1-RH-108W	3	CK	8	SA	N/9	C	0	2	A	C	CF-1	CF-3	C	NO, CSJ 7
1-RH-133	3	CK	8	SA	C/5	C	C	1	P	AC	SLT-1	SLT-1	R	NO, NOTE 1
1-RH-134	3	CK	8	SA	C/5	C	C	1	P	AC	SLT-1	SLT-1	R	NO, NOTE 1
1-SI-148	3	CK	12	SA	G/7	C	0	2	A	C	CF-1	CF-3	-	YES, NOTE 8
1-SI-151-E	3	CK	8	SA	D/7	C	0	2	A	AC	CF-1 SLT-1	CF-2 SLT-1	C R	NO, CSJ 9 NO, NOTE 1
1-SI-151-W	3	CK	8	SA	D/7	C	0	2	A	AC	CF-1 SLT-1	CF-2 SLT-1	C R	NO, CSJ 9 NO, NOTE 1
1-SI-152-N	3	CK	4	SA	D/8	C	0	2	A	AC	CF-1 SLT-1	CF-2 SLT-1	R R	YES, NOTE 10 NO, NOTE 1
1-SI-152-S	3	CK	4	SA	D/7	C	0	2	A	AC	CF-1 SLT-1	CF-2 SLT-1	R R	YES, NOTE 10 NO, NOTE 1
1-SI-158-L1	3	CK	6	SA	B/8	C	0	1	A	AC	CF-1 SLT-1	CF-2 SLT-1	- R	YES, NOTE 11 NO, NOTE 1
1-SI-158-L2	3	CK	6	SA	B/7	C	0	1	A	AC	CF-1 SLT-1	CF-2 SLT-1	- R	YES, NOTE 11 NO, NOTE 1

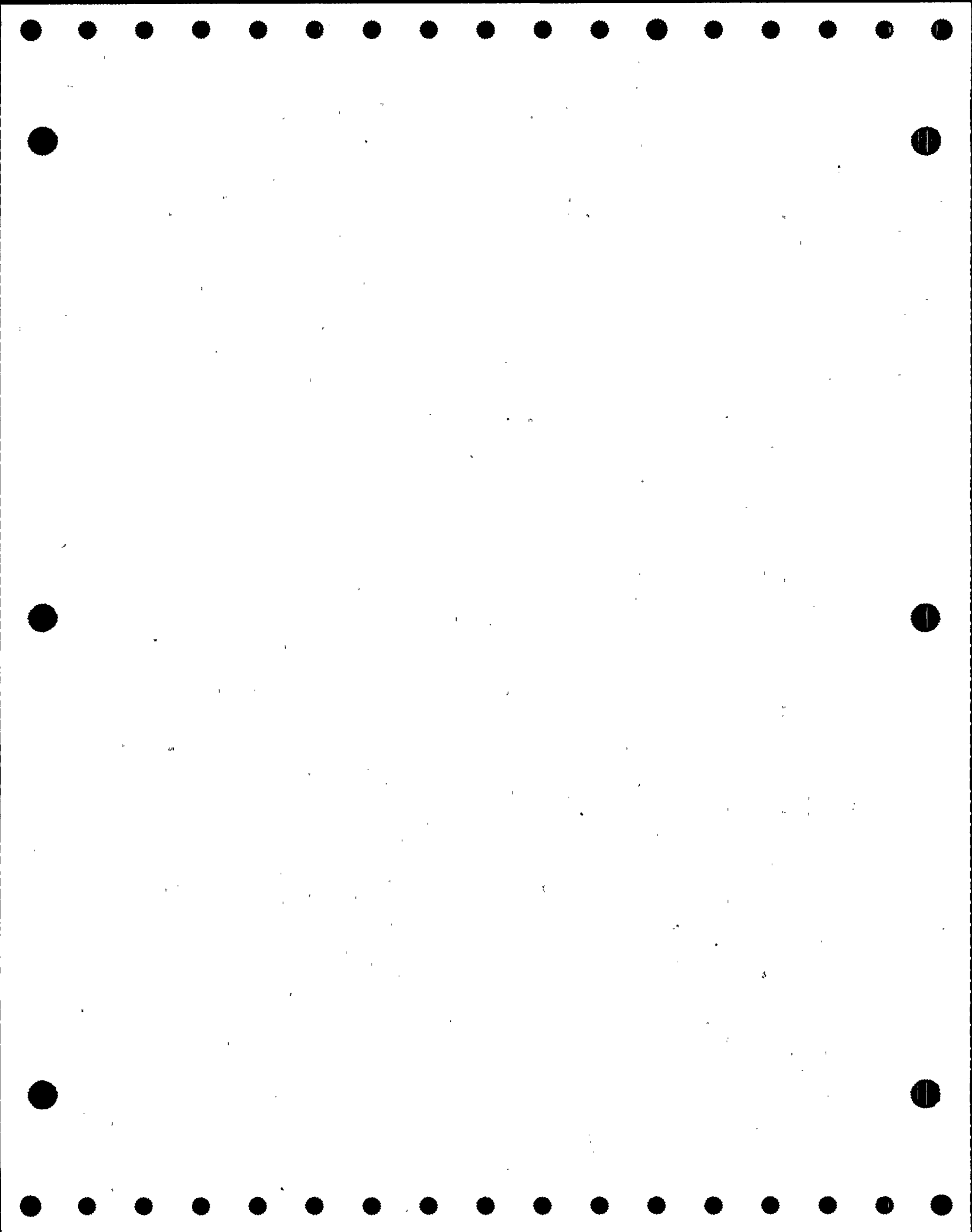

DONALD C. COOK NUCLEAR PLANT
 SECOND TEN YEAR INTERVAL
 VALVE SUMMARY SHEET - UNIT 1
 FLOW DIAGRAM: 1-5143-36

RUN DATE AND TIME: 15FEB90:16:03

SYSTEM NAME: EMERGENCY CORE COOLING - RHR

VALVE				VALVE POSITION				ASME SECTION XI						
NUMBER	REV	TYPE	SIZE	ACT TYPE	F.D. COORD	POWER OPER	SAFETY FUNCT	CD ICL	A/P	CAT	PRIM TEST REQUIRED	TEST PERFORMED	TEST MODE	RELIEF REQUEST(S)
1-SI-158-L3	3	CK	6	SA	B/7	C	0	1	A	AC	CF-1 SLT-1	CF-2 SLT-1	- R	YES, NOTE 11 NO, NOTE 1
1-SI-158-L4	3	CK	6	SA	B/7	C	0	1	A	AC	CF-1 SLT-1	CF-2 SLT-1	- R	YES, NOTE 11 NO, NOTE 1
1-SI-161-L1	3	CK	6	SA	B/6	C	0	1	A	AC	CF-1 SLT-1	CF-2 SLT-1	- R	YES, NOTE 6 NO, NOTE 1
1-SI-161-L2	3	CK	6	SA	B/5	C	0	1	A	AC	CF-1 SLT-1	CF-2 SLT-1	- R	YES, NOTE 6 NO, NOTE 1
1-SI-161-L3	3	CK	6	SA	B/5	C	0	1	A	AC	CF-1 SLT-1	CF-2 SLT-1	- R	YES, NOTE 6 NO, NOTE 1
1-SI-161-L4	3	CK	6	SA	B/6	C	0	1	A	AC	CF-1 SLT-1	CF-2 SLT-1	- R	YES, NOTE 6 NO, NOTE 1
1-SI-166-1	3	CK	10	SA	C/4	C	0	1	A	AC	CF-1 SLT-1	CF-2 SLT-1	R R	YES, NOTE 5 NO, NOTE 1
1-SI-166-2	3	CK	10	SA	C/4	C	0	1	A	AC	CF-1 SLT-1	CF-2 SLT-1	R R	YES, NOTE 5 NO, NOTE 1
1-SI-166-3	3	CK	10	SA	C/4	C	0	1	A	AC	CF-1 SLT-1	CF-2 SLT-1	R R	YES, NOTE 5 NO, NOTE 1

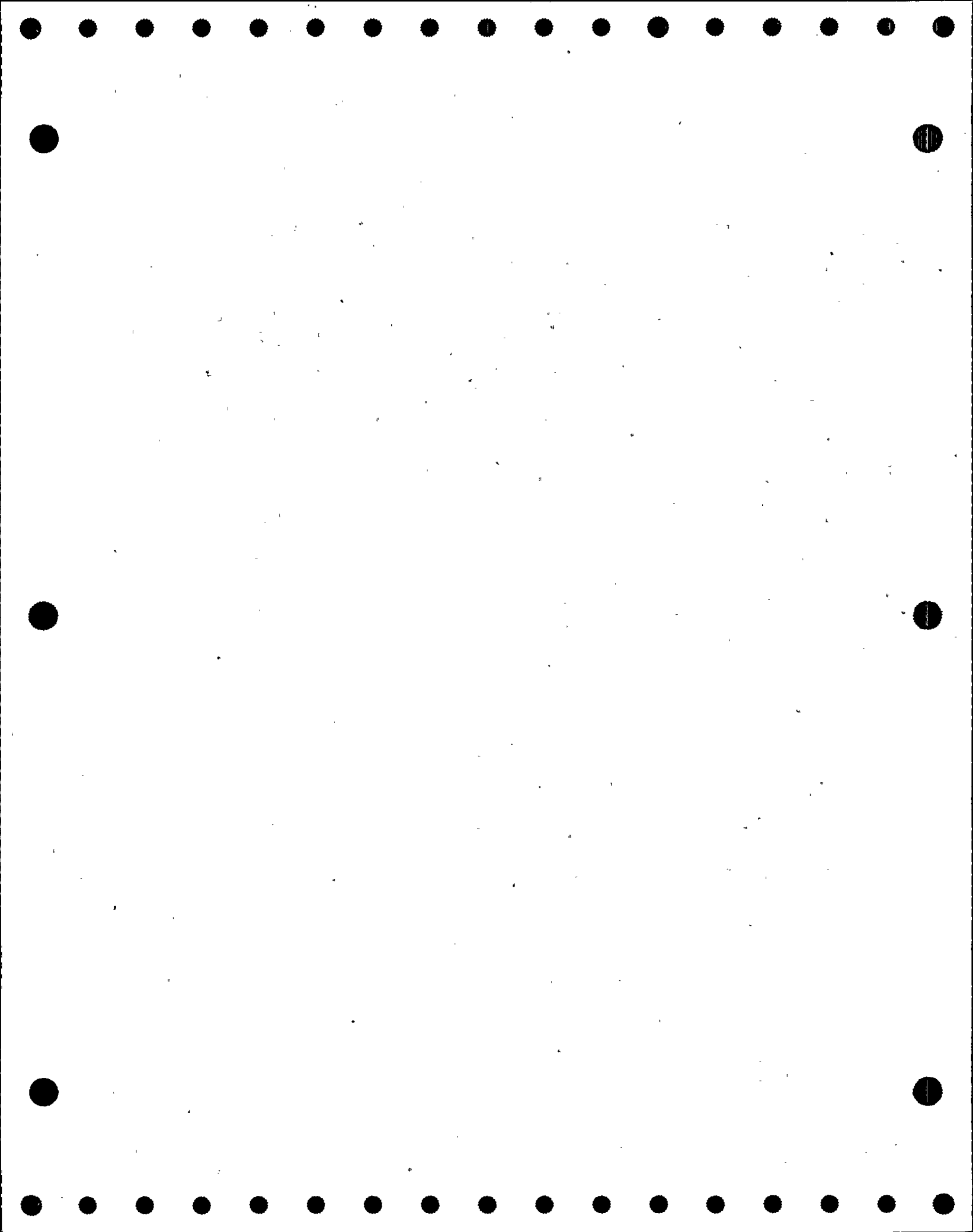

DONALD C. COOK NUCLEAR PLANT
 SECOND TEN YEAR INTERVAL
 VALVE SUMMARY SHEET - UNIT 1
 FLOW DIAGRAM: 1-5143-36

RUN DATE AND TIME: 15FEB90:16:03

SYSTEM NAME: EMERGENCY CORE COOLING - RHR

VALVE				VALVE POSITION				ASME SECTION XI							
NUMBER	REV	TYPE	SIZE	ACT TYPE	F.D. COORD	POWER OPER	SAFETY FUNCT	CD ICL	A/P	CAT	PRIM TEST REQUIRED	TEST PERFORMED	TEST MODE	RELIEF REQUEST(S)	
1-SI-166-4	3	CK	10	SA	C/4	C	0	1	A	AC	CF-1 SLT-1	CF-2 SLT-1	R R	YES, NOTE 5 NO, NOTE 1	
1-SI-170-L1	3	CK	10	SA	A/4	C	0	1	A	AC	CF-1 SLT-1	CF-3 SLT-1	R R	YES, NOTE 12 NO, NOTE 1	
1-SI-170-L2	3	CK	10	SA	A/5	C	0/C	1	A	AC	CF-1 SLT-1	CF-3 SLT-1	R R	YES, NOTE 12 NO, NOTE 1	
1-SI-170-L3	3	CK	10	SA	A/5	C	0/C	1	A	AC	CF-1 SLT-1	CF-3 SLT-1	R R	YES, NOTE 12 NO, NOTE 1	
1-SI-170-L4	3	CK	10	SA	A/4	C	0	1	A	AC	CF-1 SLT-1	CF-3 SLT-1	R R	YES, NOTE 12 NO, NOTE 1	
1-SI-171	3	GL	0.75	M	H/6	C	C	2	P	A	SLT-1	SLT-2	R	YES, NOTE 14	
1-SI-172	3	GL	0.75	M	H/6	C	C	2	P	A	SLT-1	SLT-2	R	YES, NOTE 14	
1-SI-194	3	GL	0.75	M	G/6	C	C	2	P	A	SLT-1	SLT-2	R	YES, NOTE 14	
1-SV-100-1	3	REL	1	SA	D/1	C	0	2	A	C	TF-1	TF-1	R	NO	
1-SV-100-2	3	REL	1	SA	D/1	C	0	2	A	C	TF-1	TF-1	R	NO	

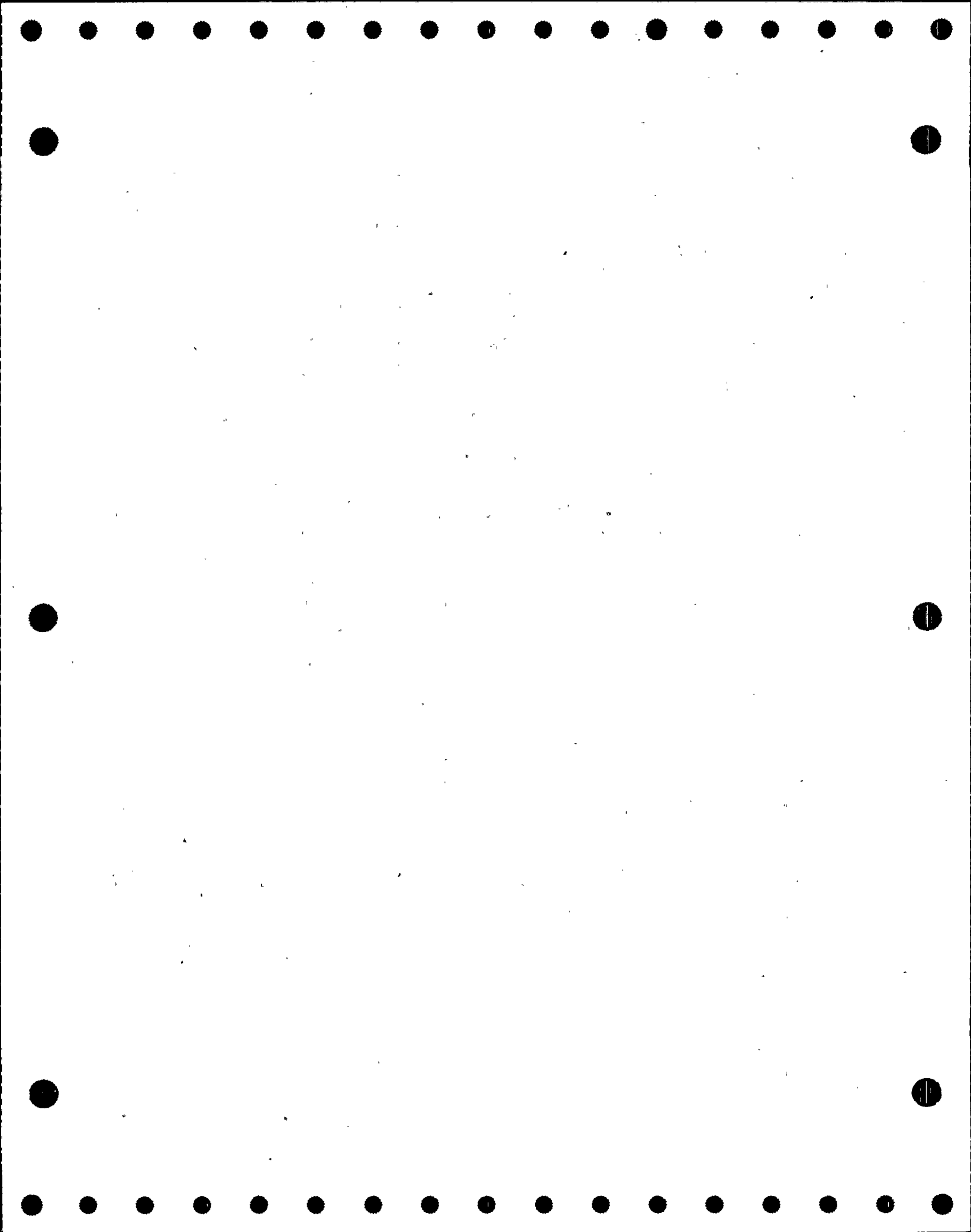

DONALD C. COOK NUCLEAR PLANT
 SECOND TEN YEAR INTERVAL
 VALVE SUMMARY SHEET - UNIT 1
 FLOW DIAGRAM: 1-5143-36

RUN DATE AND TIME: 15FEB90:16:03

SYSTEM NAME: EMERGENCY CORE COOLING - RHR

VALVE				VALVE POSITION				ASME SECTION XI						
NUMBER	REV	TYPE	SIZE	ACT TYPE	F.D. COORD	POWER OPER	SAFETY FUNCT	CD ICL	A/P	CAT	PRIM TEST REQUIRED	TEST PERFORMED	TEST MODE	RELIEF REQUEST(S)
1-SV-100-3	3	REL	1	SA	D/1	C	0	2	A	C	TF-1	TF-1	R	NO
1-SV-100-4	3	REL	1	SA	D/1	C	0	2	A	C	TF-1	TF-1	R	NO
1-SV-102	3	REL	0.75	SA	E/5	C	0	2	A	C	TF-1	TF-1	R	NO
1-SV-103	3	REL	3	SA	F/8	C	0	2	A	C	TF-1	TF-1	R	NO
1-SV-104E	3	REL	2	SA	G/4	C	0	2	A	C	TF-1	TF-1	R	NO
1-SV-104H	3	REL	2	SA	K/4	C	0	2	A	C	TF-1	TF-1	R	NO
1-SV-105E	3	REL	2	SA	D/9	C	0	2	A	C	TF-1	TF-1	R	NO
1-SV-105H	3	REL	2	SA	D/9	C	0	2	A	C	TF-1	TF-1	R	NO

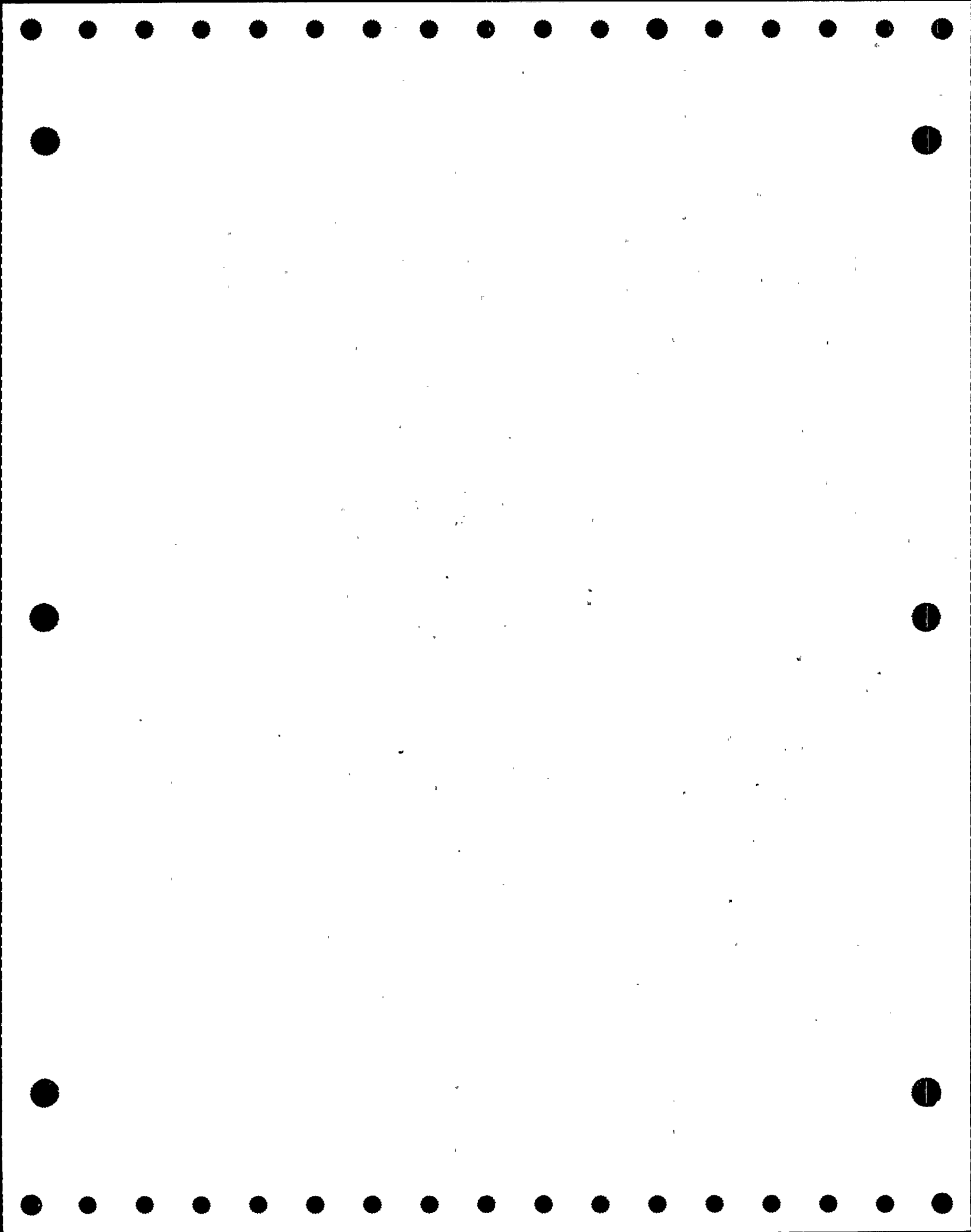

DONALD C. COOK NUCLEAR PLANT
 SECOND TEN YEAR INTERVAL
 VALVE SUMMARY SHEET - UNIT 1
 FLOW DIAGRAM: 1-5144-28

RUN DATE AND TIME: 15FEB90:16:03

SYSTEM NAME: CONTAINMENT SPRAY

VALVE				VALVE POSITION				ASME SECTION XI						
NUMBER	REV	TYPE	SIZE	ACT TYPE	F.D. COORD	POWER OPER	SAFETY FUNCT	CD A/P ICL	CAT	PRIM TEST REQUIRED	TEST PERFORMED	TEST MODE	RELIEF REQUEST(S)	
1-CTS-103-E	3	CK	10	SA	J/9	C	0	2	A	C	CF-1	CF-3	-	YES, NOTE 2
1-CTS-103-W	3	CK	10	SA	L/9	C	0	2	A	C	CF-1	CF-3	-	YES, NOTE 2
1-CTS-109	3	VB	1	SA	M/6	C	0	2	A	C	CF-1	CF-2	C	NO, CSJ 6
1-CTS-110	3	VB	1	SA	M/6	C	0	2	A	C	CF-1	CF-2	C	NO, CSJ 6
1-CTS-120-E	3	CK	2	SA	H/8	C	0	2	A	C	CF-1	CF-1	P	NO
1-CTS-120-W	3	CK	2	SA	K/8	C	0	2	A	C	CF-1	CF-1	P	NO
1-CTS-127-E	3	CK	6	SA	E/5	C	0	2	A	AC	CF-1 SLT-1	CF-2 SLT-2A	R R	YES, NOTE 4 YES, NOTE 7
1-CTS-127-W	3	CK	6	SA	E/4	C	0	2	A	AC	CF-1 SLT-1	CF-2 SLT-2A	R R	YES, NOTE 4 YES, NOTE 7
1-CTS-131-E	3	CK	8	SA	E/2	C	0	2	A	AC	CF-1 SLT-1	CF-2 SLT-2A	R R	YES, NOTE 3 YES, NOTE 7
1-CTS-131-W	3	CK	8	SA	E/2	C	0	2	A	AC	CF-1 SLT-1	CF-2 SLT-2A	R R	YES, NOTE 3 YES, NOTE 7
1-CTS-138-E	3	CK	12	SA	G/9	C	0/C	2	A	C	CF-1	CF-3	-	YES, NOTE 1

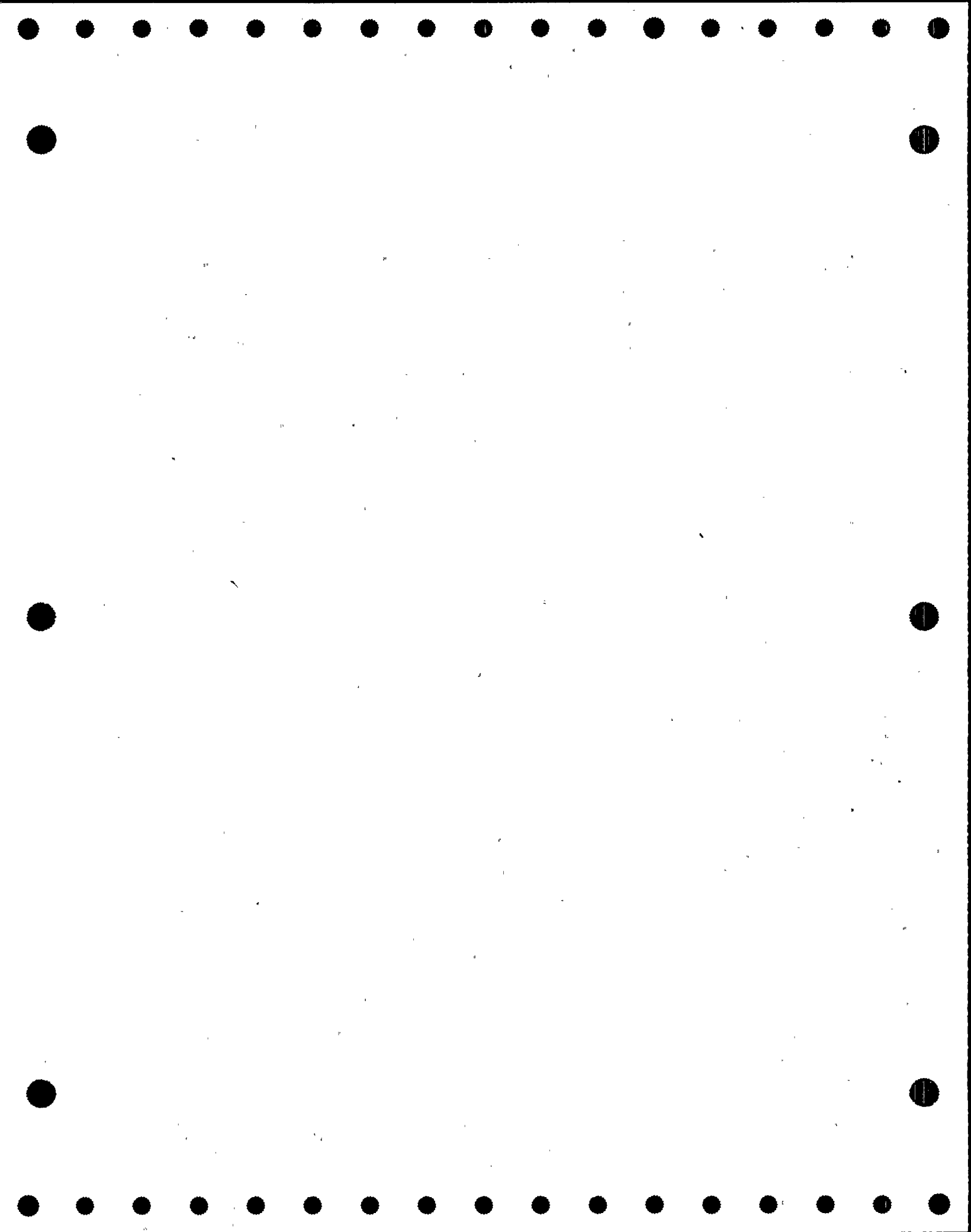

DONALD C. COOK NUCLEAR PLANT
 SECOND TEN YEAR INTERVAL
 VALVE SUMMARY SHEET - UNIT 1
 FLOW DIAGRAM: 1-5144-28

RUN DATE AND TIME: 15FEB90:16:03

SYSTEM NAME: CONTAINMENT SPRAY

VALVE				VALVE POSITION				ASME SECTION XI						
NUMBER	REV	TYPE	SIZE	ACT TYPE	F.D. COORD	POWER OPER	SAFETY FUNCT	CD ICL	A/P	CAT	PRIM TEST REQUIRED	TEST PERFORMED	TEST MODE	RELIEF REQUEST(S)
1-CTS-138-W	3	CK	12	SA	J/9	C	O/C	2	A	C	CF-1	CF-3	-	YES, NOTE 1
1-IMO-202	3	GA	2.5	MO	M/7	C	O	2	A	B	EF-1 EF-5 ET-XXX	EF-1 EF-5 ET-XXX	P - P	NO NO NO
1-IMO-204	3	GA	2.5	MO	M/7	C	O	2	A	B	EF-1 EF-5 ET-XXX	EF-1 EF-5 ET-XXX	P - P	NO NO NO
1-IMO-210	3	GA	10	MO	J/8	C	O	2	A	B	EF-1 EF-5 ET-XXX	EF-1 EF-5 ET-XXX	P - P	NO NO NO
1-IMO-211	3	GA	10	MO	J/8	C	O	2	A	B	EF-1 EF-5 ET-XXX	EF-1 EF-5 ET-XXX	P - P	NO NO NO
1-IMO-212	3	GA	2	MO	H/8	O	O/C	2	A	B	EF-1 EF-5 ET-XXX	EF-1 EF-5 ET-XXX	P - P	NO NO NO
1-IMO-215	3	GA	12	MO	G/9	O	O/C	2	A	B	EF-1 EF-5 ET-XXX	EF-1 EF-5 ET-XXX	P - P	NO NO NO
1-IMO-220	3	GA	10	MO	L/8	C	O	2	A	B	EF-1 EF-5 ET-XXX	EF-1 EF-5 ET-XXX	P - P	NO NO NO

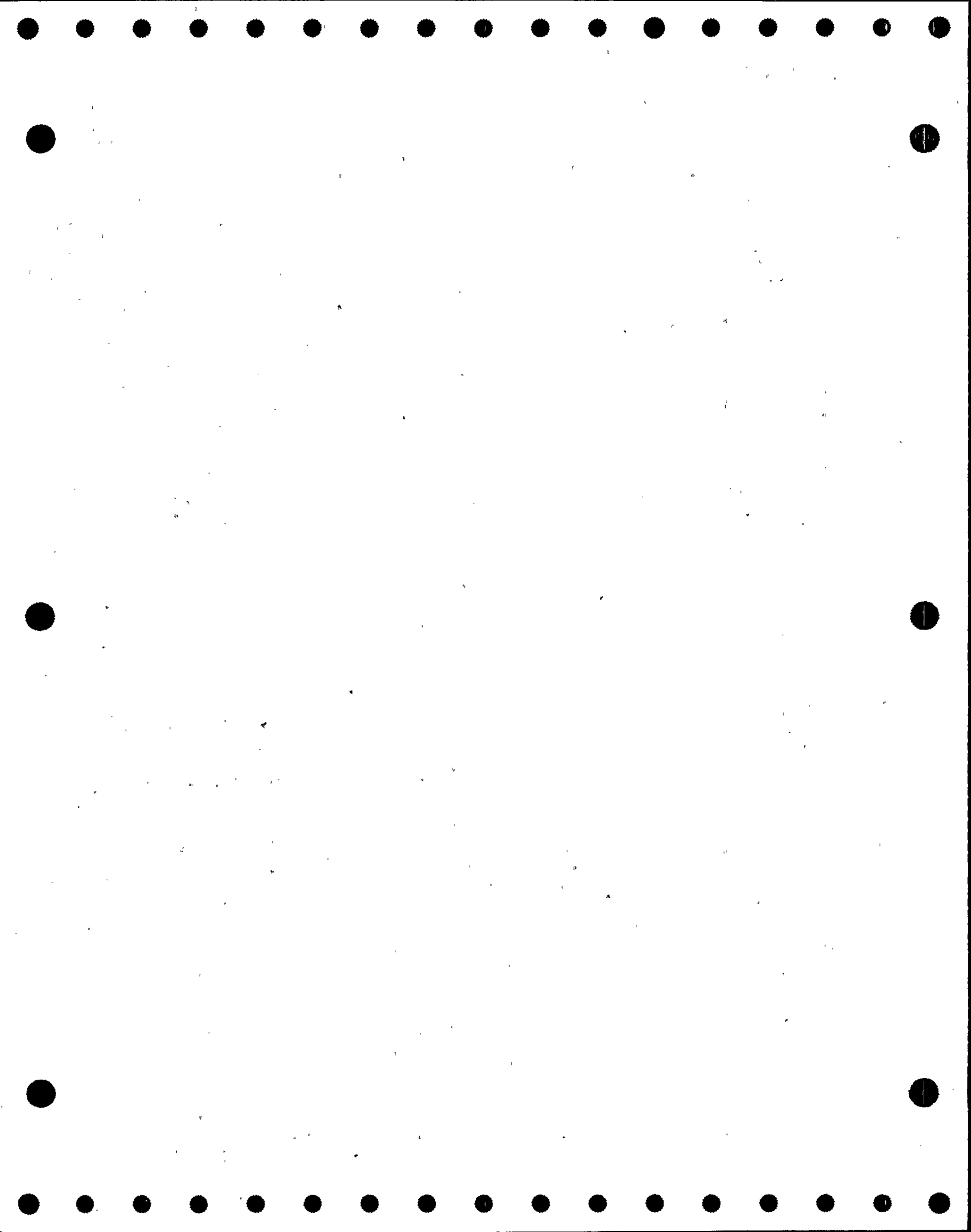

DONALD C. COOK NUCLEAR PLANT
 SECOND TEN YEAR INTERVAL
 VALVE SUMMARY SHEET - UNIT 1
 FLOW DIAGRAM: 1-5144-28

RUN DATE AND TIME: 15FEB90:16:03

SYSTEM NAME: CONTAINMENT SPRAY

VALVE				VALVE POSITION				ASME SECTION XI						
NUMBER	REV	TYPE	SIZE	ACT TYPE	F.D. COORD	POWER OPER	SAFETY FUNCT	CD ICL	A/P	CAT	PRIM TEST REQUIRED	TEST PERFORMED	TEST MODE	RELIEF REQUEST(S)
1-IMO-221	3	GA	10	MO	L/8	C	0	2	A	B	EF-1 EF-5 ET-XXX	EF-1 EF-5 ET-XXX	P - P	NO NO NO
1-IMO-222	3	GA	2	MO	L/9	O	O/C	2	A	B	EF-1 EF-5 ET-XXX	EF-1 EF-5 ET-XXX	P - P	NO NO NO
1-IMO-225	3	GA	12	MO	J/9	O	O/C	2	A	B	EF-1 EF-5 ET-XXX	EF-1 EF-5 ET-XXX	P - P	NO NO NO
1-RH-141	3	CK	8	SA	E/3	C	0	2	A	AC	CF-1 SLT-1	CF-2 SLT-2A	R R	YES, NOTE 5 YES, NOTE 7
1-RH-142	3	CK	8	SA	E/3	C	0	2	A	AC	CF-1 SLT-1	CF-2 SLT-2A	R R	YES, NOTE 5 YES, NOTE 7
1-SV-107	3	REL	1	SA	N/5	C	0	2	A	C	TF-1	TF-1	R	NO

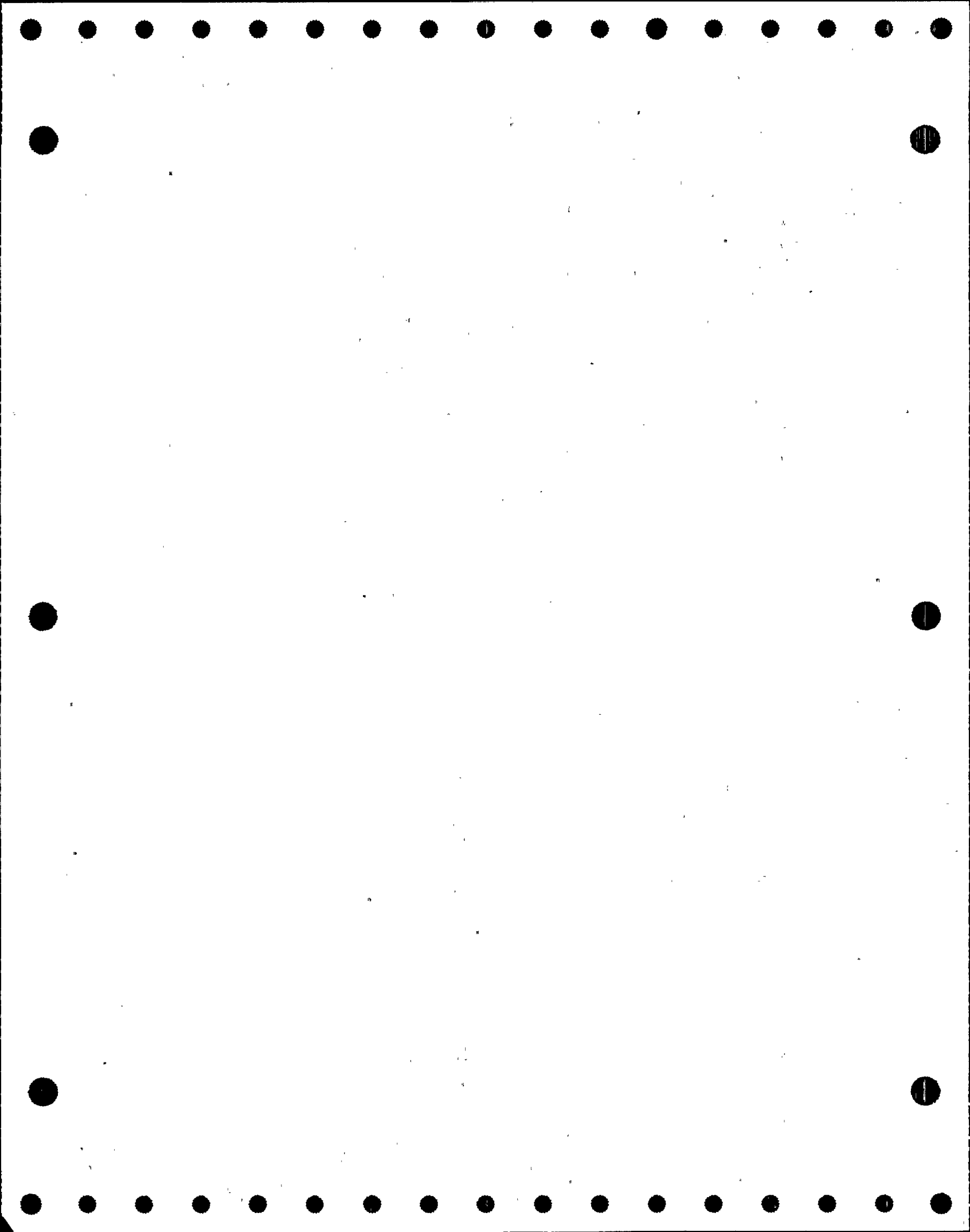

DONALD C. COOK NUCLEAR PLANT
 SECOND TEN YEAR INTERVAL
 VALVE SUMMARY SHEET - UNIT 1
 FLOW DIAGRAM: 1-5145-17

RUN DATE AND TIME: 15FEB90:16:03

SYSTEM NAME: CPN/WELD CHANNEL PRESSURIZATION

VALVE				VALVE POSITION				ASME SECTION XI					RELIEF REQUEST(S)	
NUMBER	REV	TYPE	SIZE	ACT TYPE	F.D. COORD	POWER OPER	SAFETY FUNCT	CD ICL	A/P	CAT	PRIM TEST REQUIRED	TEST PERFORMED	TEST MODE	
1-CA-181-N	3	CK	0.5	SA	F/2	C	C	2	P	AC	SLT-1	SLT-2	R	YES, NOTE 1
1-CA-181-S	3	CK	0.5	SA	F/3	C	C	2	P	AC	SLT-1	SLT-2	R	YES, NOTE 1

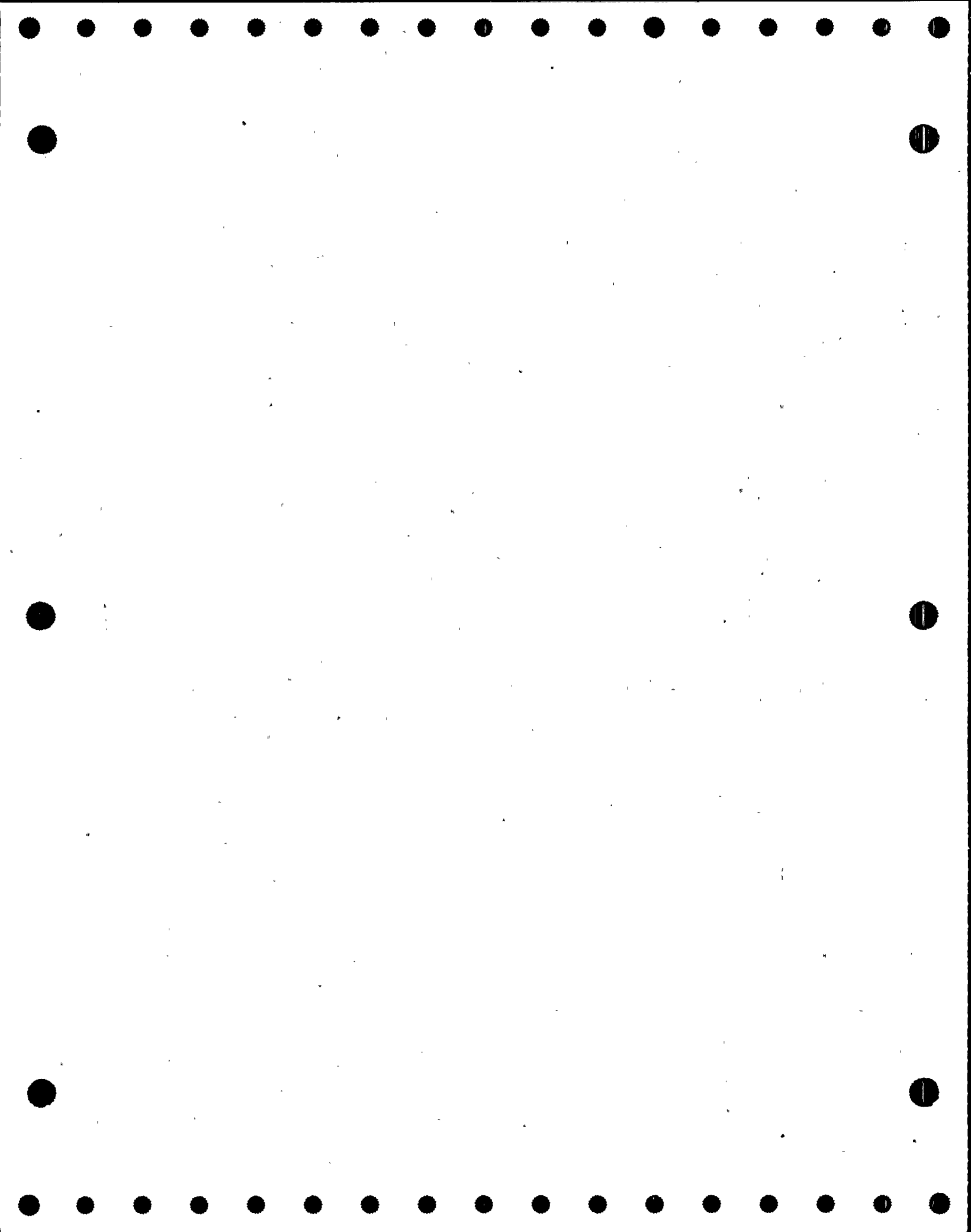

DONALD C. COOK NUCLEAR PLANT
 SECOND TEN YEAR INTERVAL
 VALVE SUMMARY SHEET - UNIT 1
 FLOW DIAGRAM: 1-5146B-24

RUN DATE AND TIME: 15FEB90:16:03

SYSTEM NAME: ICE CONDENSER REFRIGERATION

VALVE				VALVE POSITION				ASME SECTION XI						
NUMBER	REV	TYPE	SIZE	ACT TYPE	F.D. COORD	POWER OPER	SAFETY FUNCT	CD ICL	A/P	CAT	PRIM TEST REQUIRED	TEST PERFORMED	TEST MODE	RELIEF REQUEST(S)
1-R-156	3	CK	0.375	SA	L/4	C	O/C	2	A	AC	CF-1 SLT-1	CF-2 SLT-2	R R	YES, NOTE 1 YES, NOTE 2
1-R-157	3	CK	0.375	SA	L/6	C	O/C	2	A	AC	CF-1 SLT-1	CF-2 SLT-2	R R	YES, NOTE 1 YES, NOTE 2
1-VCR-10	3	DA	4	A	M/5	O	C	2	A	A	EF-1 EF-5 EF-7 ET-XXX SLT-1	EF-1 EF-5 EF-7 ET-XXX SLT-2	P - P P R	NO NO NO NO YES, NOTE 2
1-VCR-11	3	DA	4	A	L/5	O	C	2	A	A	EF-1 EF-5 EF-7 ET-XXX SLT-1	EF-1 EF-5 EF-7 ET-XXX SLT-2	P - P P R	NO NO NO NO YES, NOTE 2
1-VCR-20	3	DA	4	A	M/7	O	C	2	A	A	EF-1 EF-5 EF-7 ET-XXX SLT-1	EF-1 EF-5 EF-7 ET-XXX SLT-2	P - P P R	NO NO NO NO YES, NOTE 2
1-VCR-21	3	DA	4	A	L/7	O	C	2	A	A	EF-1 EF-5 EF-7 ET-XXX SLT-1	EF-1 EF-5 EF-7 ET-XXX SLT-2	P - P P R	NO NO NO NO YES, NOTE 2

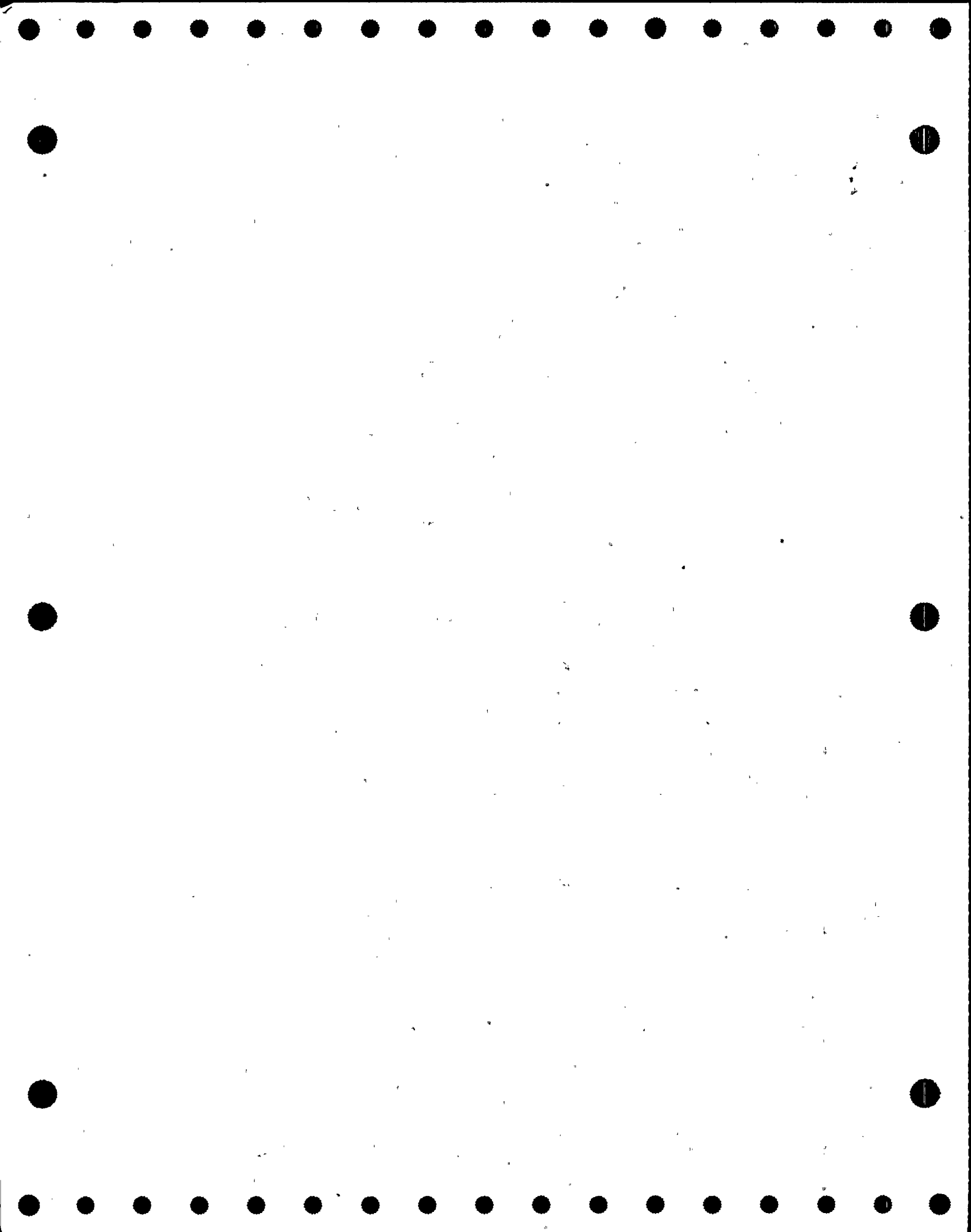

DONALD C. COOK NUCLEAR PLANT
 SECOND TEN YEAR INTERVAL
 VALVE SUMMARY SHEET - UNIT 1
 FLOW DIAGRAM: 1-5147A-34

RUN DATE AND TIME: 15FEB90:16:03

SYSTEM NAME: CONTAINMENT VENTILATION

VALVE				VALVE POSITION				ASME SECTION XI						
NUMBER	REV	TYPE	SIZE	ACT TYPE	F.D. COORD	POWER OPER	SAFETY FUNCT	CD [CL	A/P	CAT	PRIM TEST REQUIRED	TEST PERFORMED	TEST MODE	RELIEF REQUEST(S)
1-SM-10	3	GA	0.5	M	A/4	C	C	2	P	A	SLT-1	SLT-2	R	YES, NOTE 1
1-SM-4	3	GA	0.5	M	A/2	C	C	2	P	A	SLT-1	SLT-2	R	YES, NOTE 1
1-SM-6	3	GA	0.5	M	A/2	C	C	2	P	A	SLT-1	SLT-2	R	YES, NOTE 1
1-SM-8	3	GA	0.5	M	A/4	C	C	2	P	A	SLT-1	SLT-2	R	YES, NOTE 1
1-VCR-101	3	BF	14	A	J/8	C	C	2	P	A	EF-1 EF-5 EF-7 ET-XXX SLT-1	EF-1 EF-5 EF-7 ET-XXX SLT-2	P - P P R	NO NO NO NO YES, NOTE 1
1-VCR-102	3	BF	14	A	J/9	C	C	2	P	A	EF-1 EF-5 EF-7 ET-XXX SLT-1	EF-1 EF-5 EF-7 ET-XXX SLT-2	P - P P R	NO NO NO NO YES, NOTE 1
1-VCR-103	3	BF	24	A	J/5	C	C	2	P	A	EF-1 EF-5 EF-7 ET-XXX SLT-1	EF-1 EF-5 EF-7 ET-XXX SLT-2	P - P P R	NO NO NO NO YES, NOTE 1
1-VCR-104	3	BF	30	A	J/6	C	C	2	P	A	EF-1 EF-5 EF-7 ET-XXX SLT-1	EF-1 EF-5 EF-7 ET-XXX SLT-2	P - P P R	NO NO NO NO YES, NOTE 1

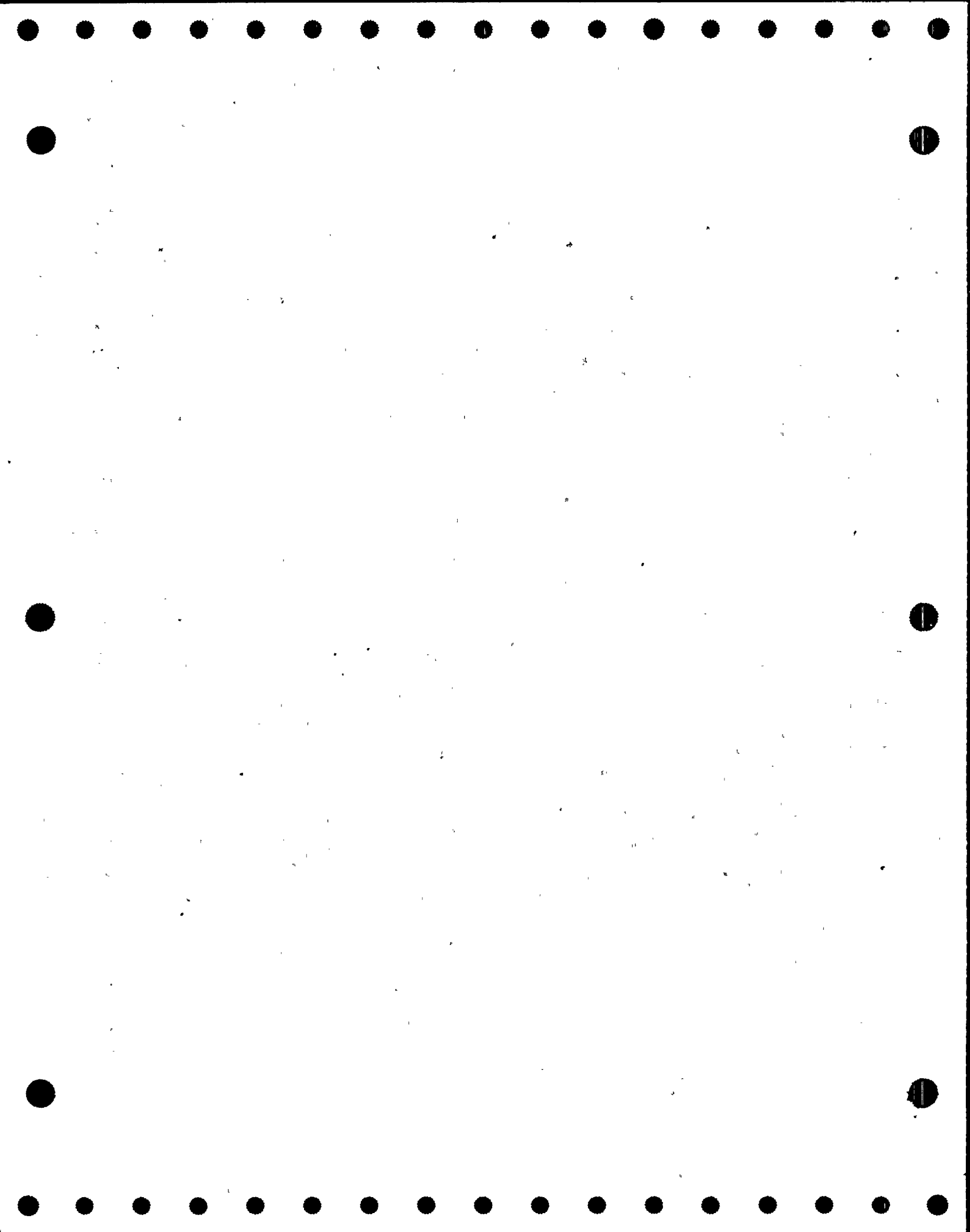

DONALD C. COOK NUCLEAR PLANT
 SECOND TEN YEAR INTERVAL
 VALVE SUMMARY SHEET - UNIT 1
 FLOW DIAGRAM: 1-5147A-34

RUN DATE AND TIME: 15FEB90:16:03

SYSTEM NAME: CONTAINMENT VENTILATION

VALVE				VALVE POSITION				ASME SECTION XI						
NUMBER	REV	TYPE	SIZE	ACT TYPE	F.D. COORD	POWER OPER	SAFETY FUNCT	CD ICL	A/P	CAT	PRIM TEST REQUIRED	TEST PERFORMED	TEST MODE	RELIEF REQUEST(S)
1-VCR-105	3	BF	30	A	J/3	C	C	2	P	A	EF-1	EF-1	P	NO
											EF-5	EF-5	-	NO
											EF-7	EF-7	P	NO
											ET-XXX	ET-XXX	P	NO
											SLT-1	SLT-2	R	YES, NOTE 1
1-VCR-106	3	BF	24	A	J/3	C	C	2	P	A	EF-1	EF-1	P	NO
											EF-5	EF-5	-	NO
											EF-7	EF-7	P	NO
											ET-XXX	ET-XXX	P	NO
											SLT-1	SLT-2	R	YES, NOTE 1
1-VCR-107	3	BF	14	A	J/4	C/O	C	2	A	A	EF-1	EF-1	P	NO
											EF-5	EF-5	-	NO
											EF-7	EF-7	P	NO
											ET-XXX	ET-XXX	P	NO
											SLT-1	SLT-2	R	YES, NOTE 1
1-VCR-201	3	BF	14	A	J/8	C	C	2	P	A	EF-1	EF-1	P	NO
											EF-5	EF-5	-	NO
											EF-7	EF-7	P	NO
											ET-XXX	ET-XXX	P	NO
											SLT-1	SLT-2	R	YES, NOTE 1
1-VCR-202	3	BF	14	A	J/9	C	C	2	P	A	EF-1	EF-1	P	NO
											EF-5	EF-5	-	NO
											EF-7	EF-7	P	NO
											ET-XXX	ET-XXX	P	NO
											SLT-1	SLT-2	R	YES, NOTE 1

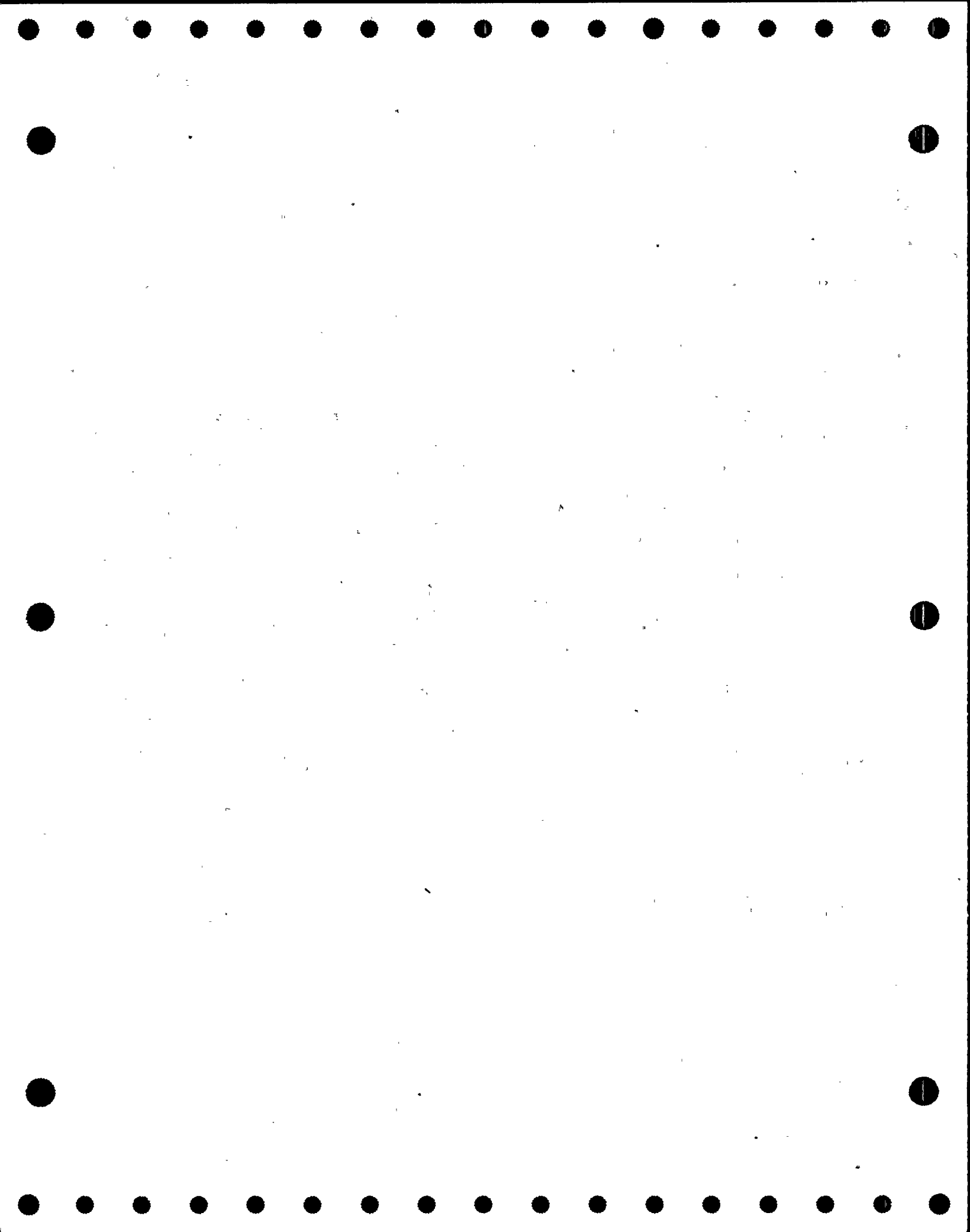

DONALD C. COOK NUCLEAR PLANT
 SECOND TEN YEAR INTERVAL
 VALVE SUMMARY SHEET - UNIT 1
 FLOW DIAGRAM: 1-5147A-34

RUN DATE AND TIME: 15FEB90:16:03

SYSTEM NAME: CONTAINMENT VENTILATION

VALVE				VALVE POSITION				ASME SECTION XI						
NUMBER	REV	TYPE	SIZE	ACT TYPE	F.D. COORD	POWER OPER	SAFETY FUNCT	CD ICL	A/P	CAT	PRIM TEST REQUIRED	TEST PERFORMED	TEST MODE	RELIEF REQUEST(S)
1-VCR-203	3	BF	24	A	J/5	C	C	2	P	A	EF-1	EF-1	P	NO
											EF-5	EF-5	-	NO
											EF-7	EF-7	P	NO
											ET-XXX	ET-XXX	P	NO
											SLT-1	SLT-2	R	YES, NOTE 1
1-VCR-204	3	BF	30	A	J/6	C	C	2	P	A	EF-1	EF-1	P	NO
											EF-5	EF-5	-	NO
											EF-7	EF-7	P	NO
											ET-XXX	ET-XXX	P	NO
											SLT-1	SLT-2	R	YES, NOTE 1
1-VCR-205	3	BF	30	A	J/3	C	C	2	P	A	EF-1	EF-1	P	NO
											EF-5	EF-5	-	NO
											EF-7	EF-7	P	NO
											ET-XXX	ET-XXX	P	NO
											SLT-1	SLT-2	R	YES, NOTE 1
1-VCR-206	3	BF	24	A	J/3	C	C	2	P	A	EF-1	EF-1	P	NO
											EF-5	EF-5	-	NO
											EF-7	EF-7	P	NO
											ET-XXX	ET-XXX	P	NO
											SLT-1	SLT-2	R	YES, NOTE 1
1-VCR-207	3	BF	14	A	J/4	C/O	C	2	A	A	EF-1	EF-1	P	NO
											EF-5	EF-5	-	NO
											EF-7	EF-7	P	NO
											ET-XXX	ET-XXX	P	NO
											SLT-1	SLT-2	R	YES, NOTE 1

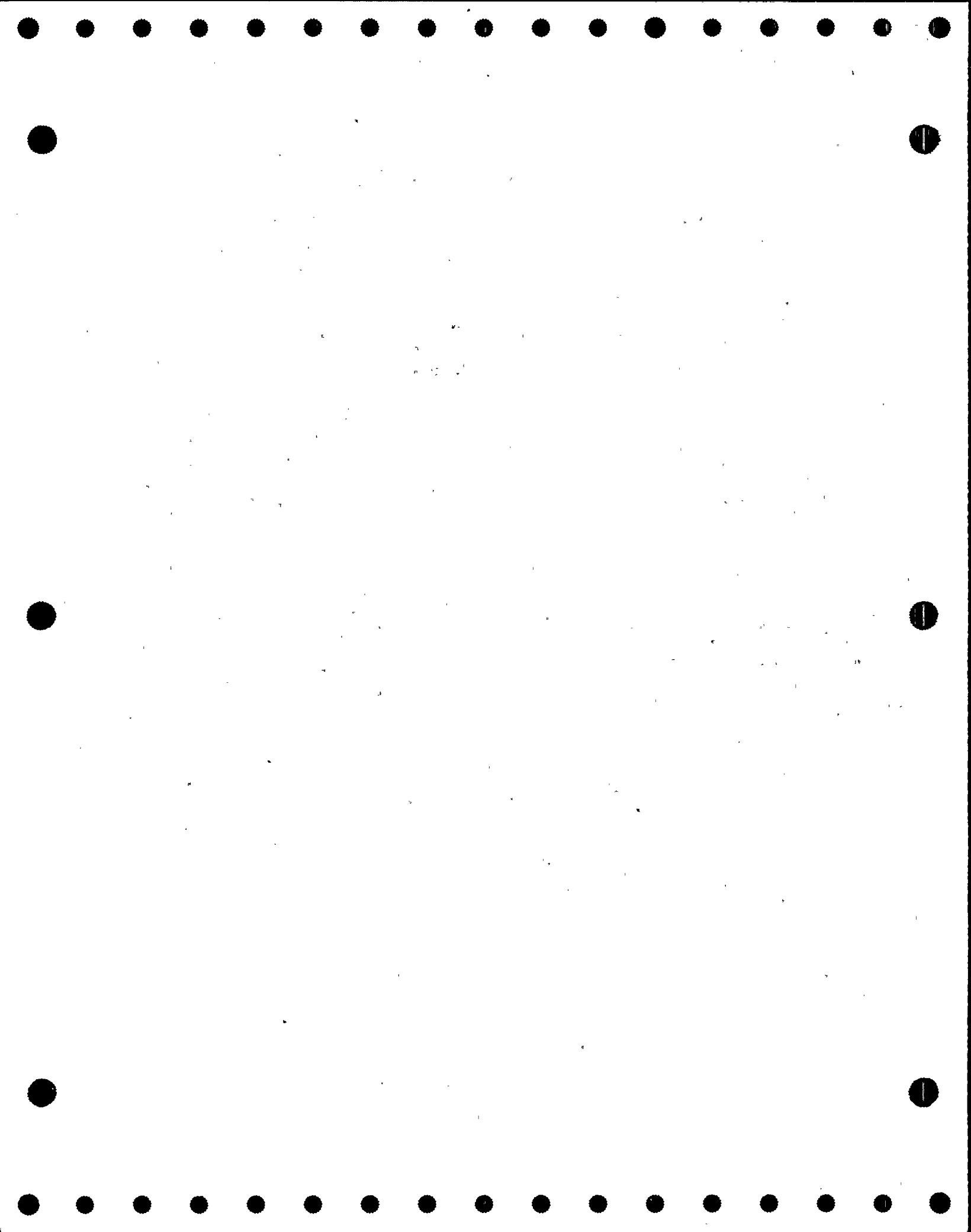

DONALD C. COOK NUCLEAR PLANT
 SECOND TEN YEAR INTERVAL
 VALVE SUMMARY SHEET - UNIT 1
 FLOW DIAGRAM: 1-5149-20

RUN DATE AND TIME: 15FEB90:16:03

SYSTEM NAME: CONTROL ROOM VENTILATION

VALVE				VALVE POSITION				ASME SECTION XI						
NUMBER	REV	TYPE	SIZE	ACT TYPE	F.D. COORD	POWER OPER	SAFETY FUNCT	CD ICL	A/P	CAT	PRIM TEST REQUIRED	TEST PERFORMED	TEST MODE	RELIEF REQUEST(S)
1-DW-163-N	3	GA	2.5	M	F/2	0	O/C	3	A	B	EF-1	EF-1	P	NO
1-DW-163-S	3	GA	2.5	M	G/2	0	O/C	3	A	B	EF-1	EF-1	P	NO
1-DW-166-N	3	GA	2.5	M	E/5	0	O/C	3	A	B	EF-1	EF-1	P	NO
1-DW-166-S	3	GA	2.5	M	J/5	0	O/C	3	A	B	EF-1	EF-1	P	NO
1-VRV-315	3	3W	2.5	A	F/5	0	0	3	A	B	EF-1 EF-7 ET-XXX	NOTE 1 EF-7 NOTE 1	P P -	YES, NOTE 1 NO, NOTE 1 YES, NOTE 1
1-VRV-325	3	3W	2.5	A	G/5	0	0	3	A	B	EF-1 EF-7 ET-XXX	NOTE 1 EF-7 NOTE 1	P P -	YES, NOTE 1 NO, NOTE 1 YES, NOTE 1

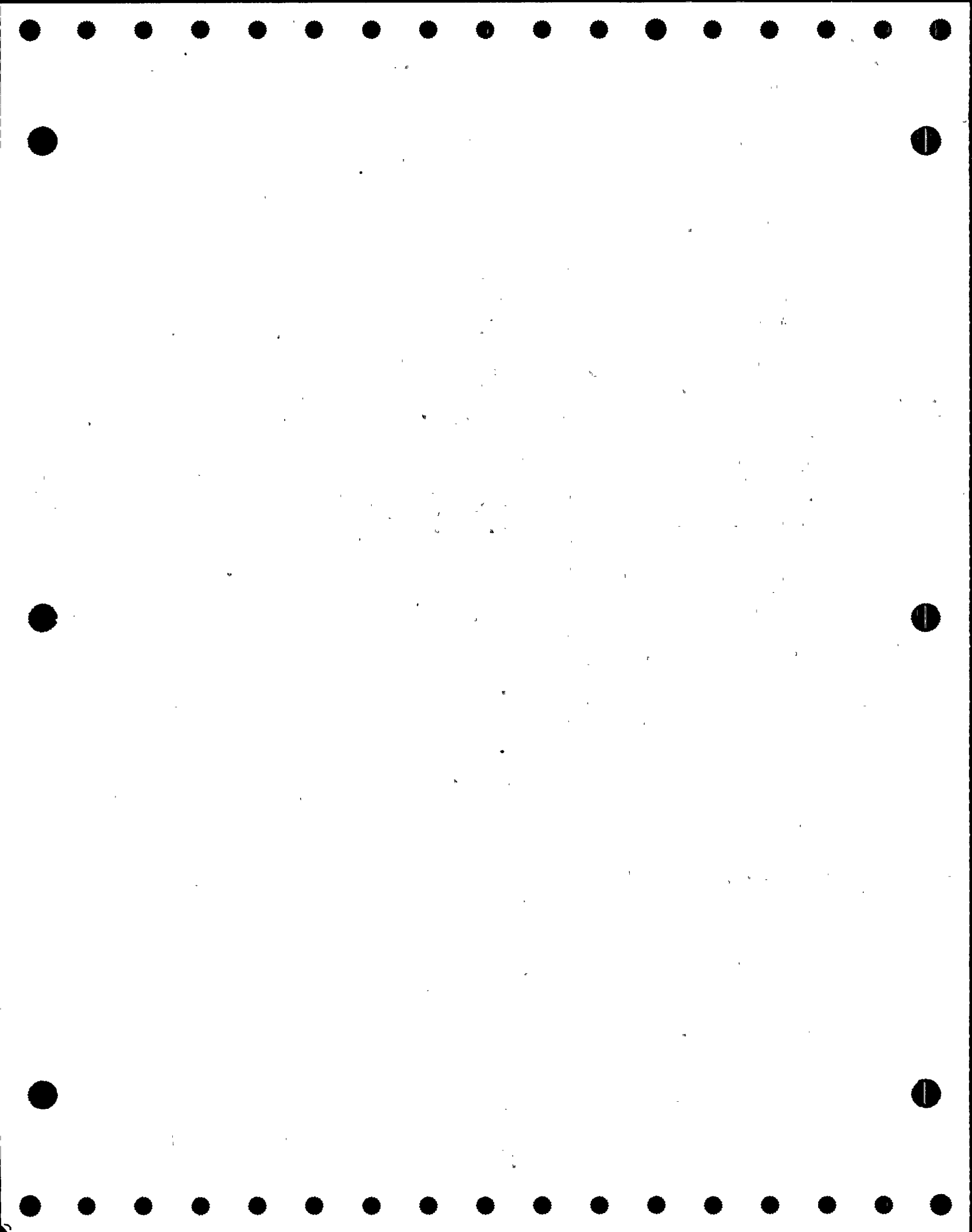

DONALD C. COOK NUCLEAR PLANT
 SECOND TEN YEAR INTERVAL
 VALVE SUMMARY SHEET - UNIT 1
 FLOW DIAGRAM: 1-5151A-25

RUN DATE AND TIME: 15FEB90:16:03

SYSTEM NAME: EMERGENCY DIESEL GENERATOR

VALVE				VALVE POSITION				ASME SECTION XI						
NUMBER	REV	TYPE	SIZE	ACT TYPE	F.D. COORD	POWER OPER	SAFETY FUNCT	CD ICL	A/P	CAT	PRIM TEST REQUIRED	TEST PERFORMED	TEST MODE	RELIEF REQUEST(S)
1-DL-113A	3	CK	1.5	SA	B/9	0	C	3	A	C	CF-1	CF-1	P	NO, NOTE 1
1-DL-115A	3	CK	1.5	SA	B/9	C	0	3	A	C	CF-1	CF-1	P	NO, NOTE 1
1-DL-125A	3	CK	2.5	SA	E/9	0	C	3	A	C	CF-1	CF-1	P	NO, NOTE 1
1-DL-131A	3	CK	1	SA	F/9	0	C	3	A	C	CF-1	CF-1	P	NO, NOTE 1
1-DL-157A	3	CK	6	SA	G/6	C	0	3	A	C	CF-1	CF-1	P	NO, NOTE 1
1-QT-114-1AB	3	3W	6	SA	H/5	0	0	3	A	B	EF-1	NOTE 2	P	NO, NOTE 2

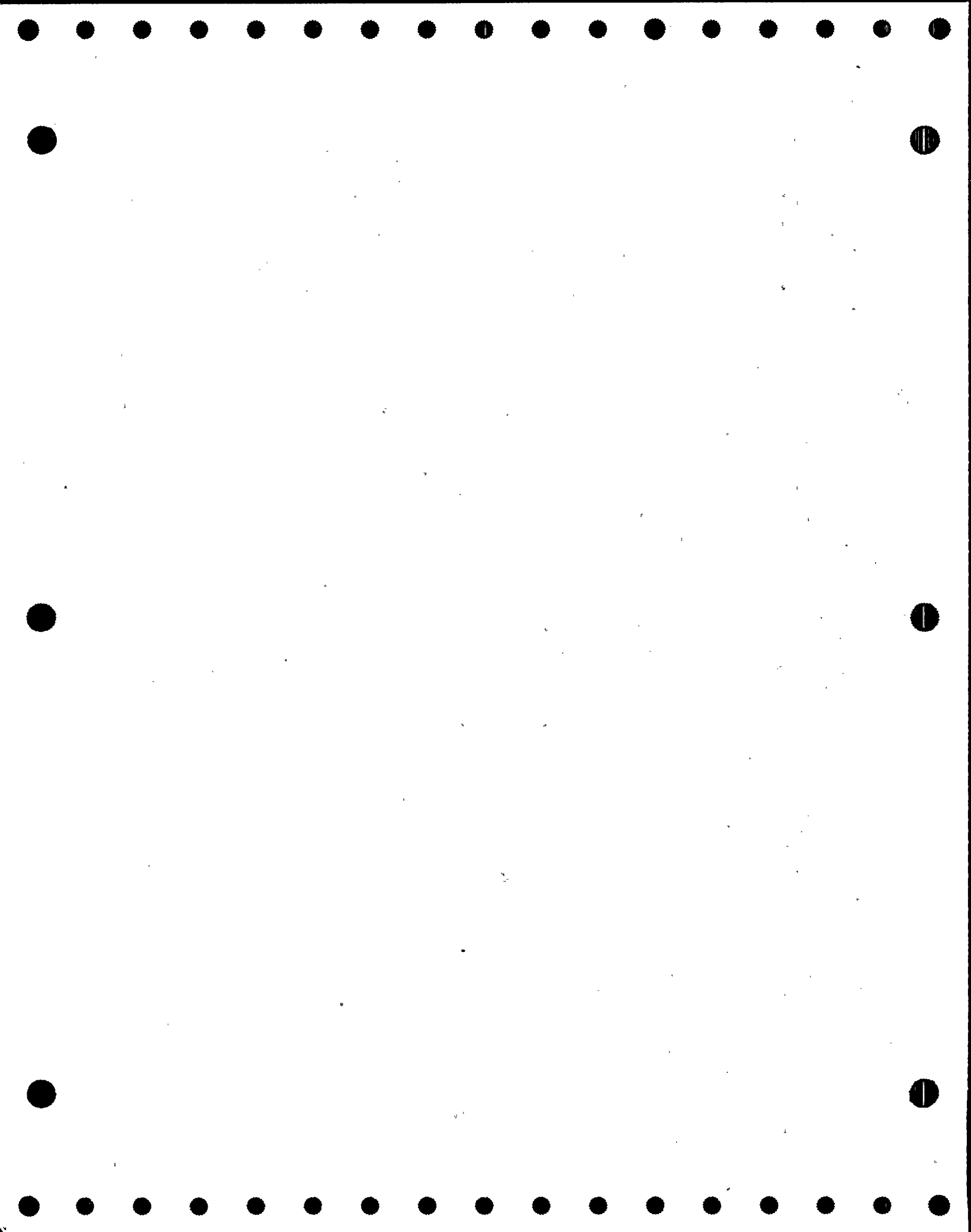

DONALD C. COOK NUCLEAR PLANT
 SECOND TEN YEAR INTERVAL
 VALVE SUMMARY SHEET - UNIT 1
 FLOW DIAGRAM: 1-5151B-28

RUN DATE AND TIME: 15FEB90:16:03

SYSTEM NAME: EMERGENCY DIESEL GENERATOR

VALVE				VALVE POSITION				ASME SECTION XI						
NUMBER	REV	TYPE	SIZE	ACT TYPE	F.D. COORD	POWER OPER	SAFETY FUNC	CD ICL	A/P	CAT	PRIM TEST REQUIRED	TEST PERFORMED	TEST MODE	RELIEF REQUEST(S)
1-DG-101A	3	CK	1.5	SA	H/4	O	O/C	3	A	C	CF-1	CF-1	P	NO, NOTE 1
1-DG-103A	3	CK	1.5	SA	F/3	O	O/C	3	A	C	CF-1	CF-1	P	NO, NOTE 1
1-DG-127A	3	CK	1	SA	C/4	C	O	3	A	C	CF-1	CF-1	P	NO, NOTE 1
1-DG-129A	3	CK	1	SA	C/4	C	O	3	A	C	CF-1	CF-1	P	NO, NOTE 1
1-DG-139A	3	CK	0.5	SA	F/1	C	O/C	3	A	C	CF-1	CF-1	P	NO
1-DG-141A	3	CK	0.5	SA	F/1	C	O/C	3	A	C	CF-1	CF-1	P	NO
1-DG-145A	3	CK	2	SA	A/8	O	C	3	A	C	CF-1	CF-1	P	NO, NOTE 1
1-DG-151A	3	CK	4	SA	D/8	C	O	3	A	C	CF-1	CF-1	P	NO, NOTE 1
1-DG-153A	3	CK	4	SA	C/8	C	O	3	A	C	CF-1	CF-1	P	NO, NOTE 1
1-QT-132-1AB	3	3W	6	SA	E/8	O	O	3	A	B	EF-1	NOTE 2	P	NO, NOTE 2
1-SV-120-1AB	3	REL	0.25	SA	G/2	C	O	3	A	C	TF-1	TF-1	R	NO
1-SV-139-1AB	3	REL	1	SA	B/2	C	O	3	A	C	TF-1	TF-1	R	NO

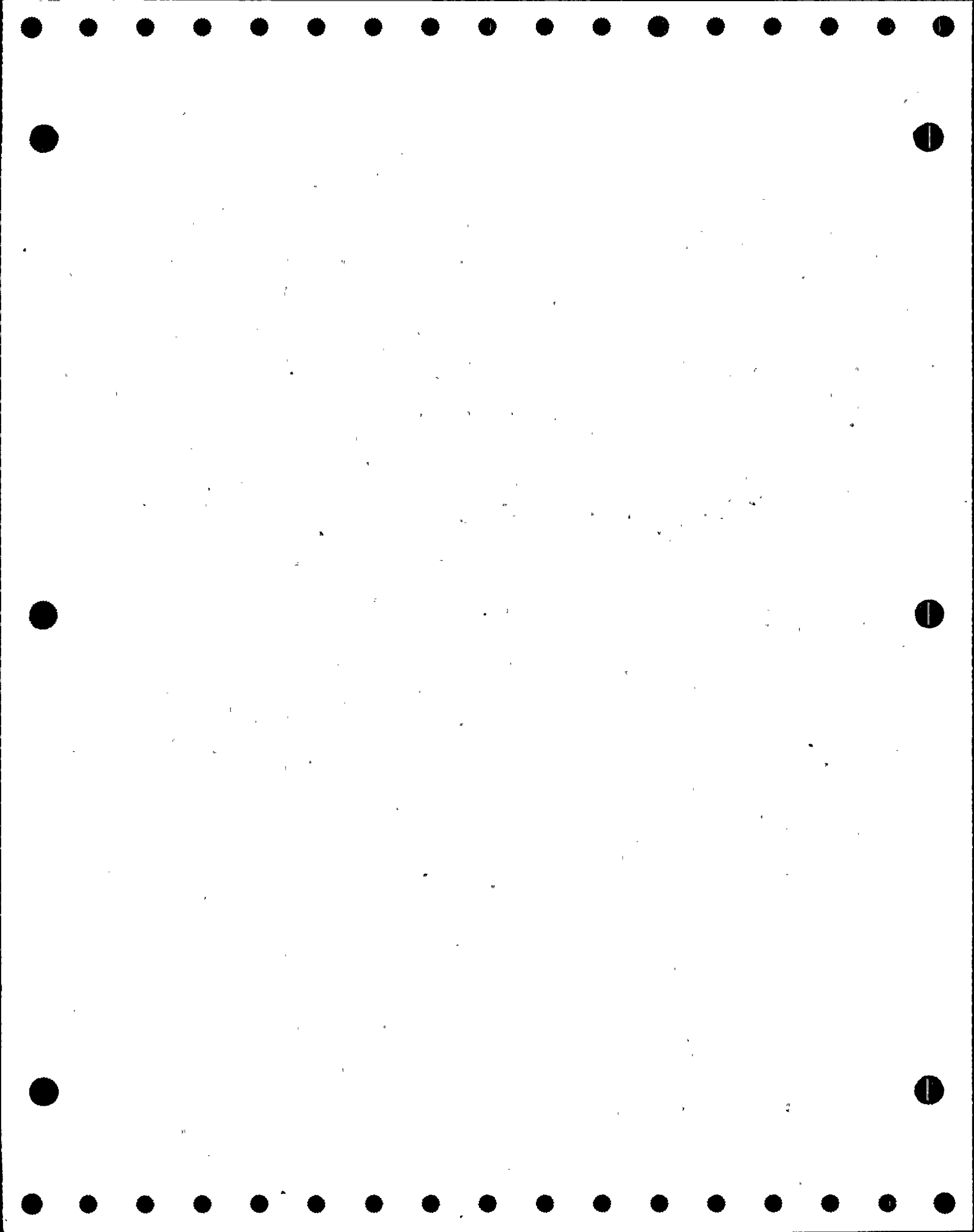

DONALD C. COOK NUCLEAR PLANT
 SECOND TEN YEAR INTERVAL
 VALVE SUMMARY SHEET - UNIT 1
 FLOW DIAGRAM: 1-5151B-28

RUN DATE AND TIME: 15FEB90:16:03

SYSTEM NAME: EMERGENCY DIESEL GENERATOR

VALVE				VALVE POSITION				ASME SECTION XI						
NUMBER	REV	TYPE	SIZE	ACT TYPE	F.D. COORD	POWER OPER	SAFETY FUNCT	CD ICL	A/P	CAT	PRIM TEST REQUIRED	TEST PERFORMED	TEST MODE	RELIEF REQUEST(S)
1-SV-61-1AB	3	REL	1	SA	A/8	C	0	3	A	C	TF-1	TF-1	R	NO
1-SV-78-1AB1	3	REL	1	SA	E/3	C	0	3	A	C	TF-1	TF-1	R	NO
1-SV-78-1AB2	3	REL	1	SA	D/3	C	0	3	A	C	TF-1	TF-1	R	NO
1-SV-79-1AB1	3	REL	0.5	SA	E/1	C	0	3	A	C	TF-1	TF-1	R	NO
1-SV-79-1AB2	3	REL	0.5	SA	E/1	C	0	3	A	C	TF-1	TF-1	R	NO
1-XRV-220	3	GA	1	A	B/3	C	0	3	A	B	EF-1 EF-7 ET-XXX	EF-1 EF-7 NOTE 4	- - -	YES, NOTE 4 NO, NOTE 4 YES, NOTE 4
1-XRV-221	3	GL	3	A	B/4	C	0	3	A	B	EF-1 EF-7 ET-XXX	EF-1 NOTE 3 NOTE 3	- - -	YES, NOTE 3 YES, NOTE 3 YES, NOTE 3
1-XRV-222	3	GL	3	A	B/4	C	0	3	A	B	EF-1 EF-7 ET-XXX	EF-1 NOTE 3 NOTE 3	- - -	YES, NOTE 3 YES, NOTE 3 YES, NOTE 3

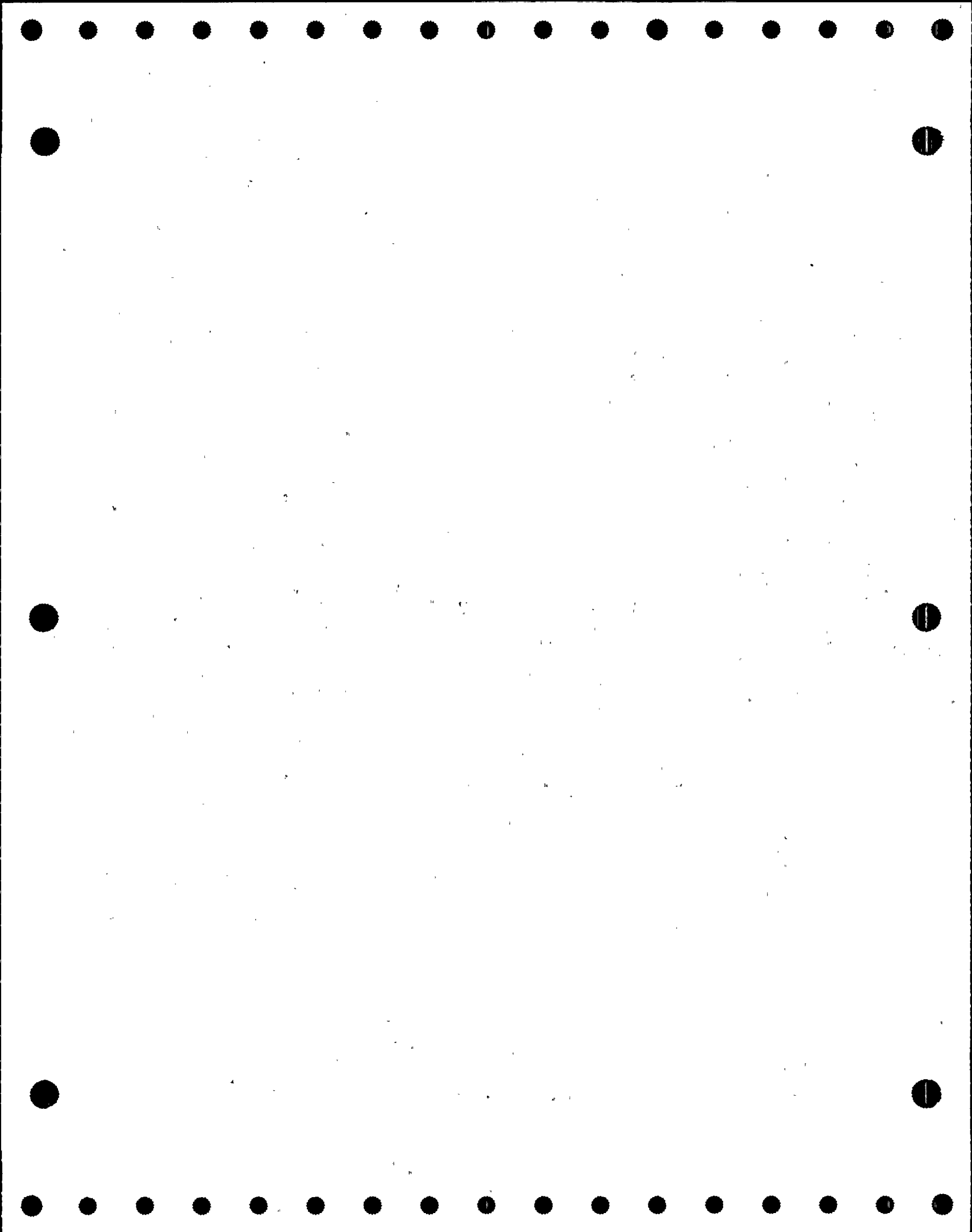

DONALD C. COOK NUCLEAR PLANT
 SECOND TEN YEAR INTERVAL
 VALVE SUMMARY SHEET - UNIT 1
 FLOW DIAGRAM: 1-5151C-26

RUN DATE AND TIME: 15FEB90:16:03

SYSTEM NAME: EMERGENCY DIESEL GENERATOR

VALVE				VALVE POSITION				ASME SECTION XI						
NUMBER	REV	TYPE	SIZE	ACT TYPE	F.D. COORD	POWER OPER	SAFETY FUNCT	CD ICL	A/P	CAT	PRIM TEST REQUIRED	TEST PERFORMED	TEST MODE	RELIEF REQUEST(S)
1-DF-108C	3	CK	1.5	SA	J/3	C	0	3	A	C	CF-1	CF-1	P	NO, NOTE 1
1-DF-109C	3	CK	1.5	SA	K/3	C	0	3	A	C	CF-1	CF-1	P	NO, NOTE 1
1-DF-114C	3	CK	1.5	SA	L/3	C	0	3	A	C	CF-1	CF-1	P	NO, NOTE 1
1-DF-115C	3	CK	1.5	SA	M/3	C	0	3	A	C	CF-1	CF-1	P	NO, NOTE 1
1-DL-113C	3	CK	1.5	SA	B/9	O	C	3	A	C	CF-1	CF-1	P	NO, NOTE 1
1-DL-115C	3	CK	1.5	SA	B/9	C	0	3	A	C	CF-1	CF-1	P	NO, NOTE 1
1-DL-125C	3	CK	2.5	SA	E/9	O	C	3	A	C	CF-1	CF-1	P	NO, NOTE 1
1-DL-131C	3	CK	1	SA	F/9	O	C	3	A	C	CF-1	CF-1	P	NO, NOTE 1
1-DL-157C	3	CK	6	SA	G/5	C	0	3	A	C	CF-1	CF-1	P	NO, NOTE 1
1-QT-114-1CD	3	3W	6	SA	H/5	O	0	3	A	B	EF-1	NOTE 2	P	NO, NOTE 2

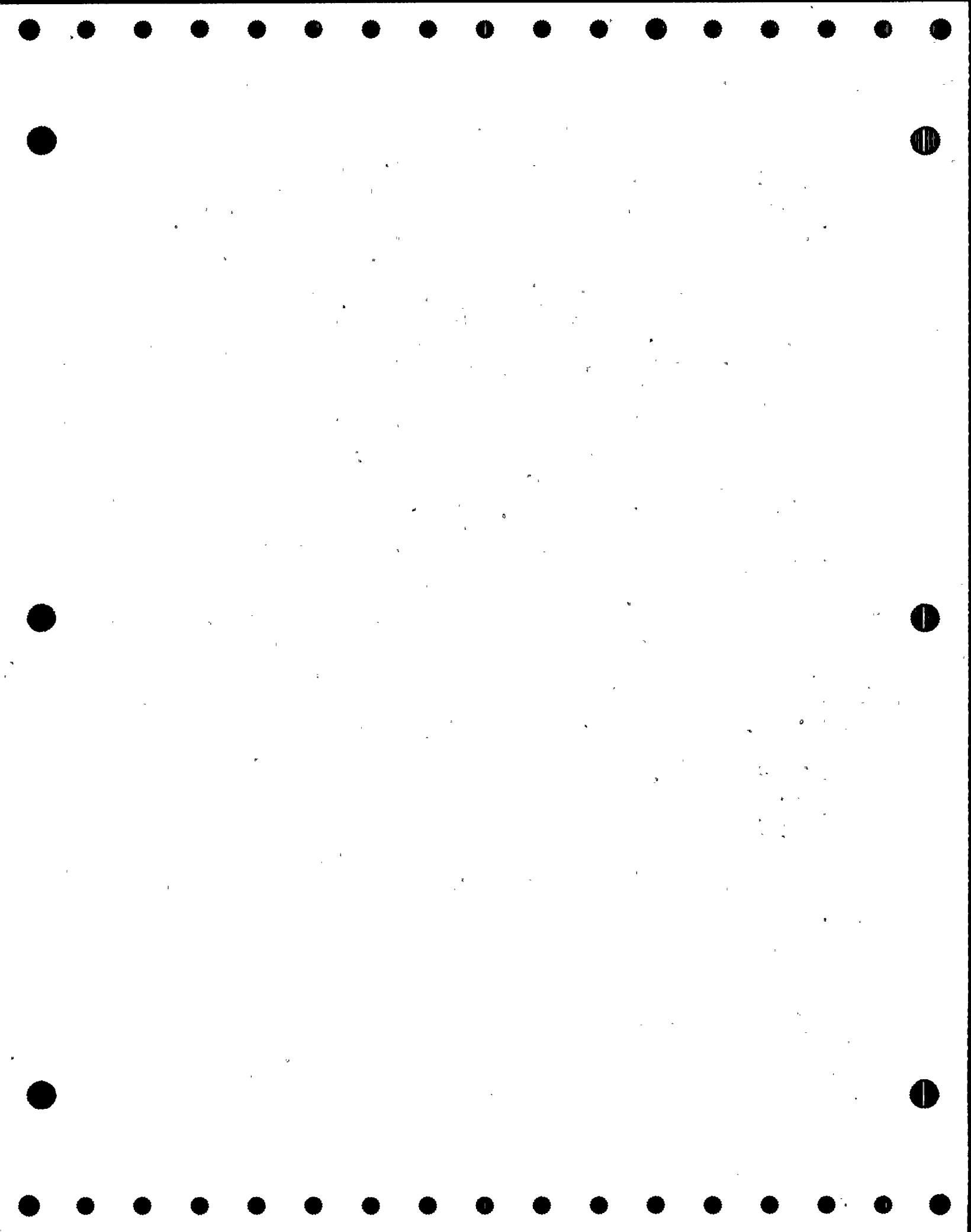

DONALD C. COOK NUCLEAR PLANT
 SECOND TEN YEAR INTERVAL
 VALVE SUMMARY SHEET - UNIT 1
 FLOW DIAGRAM: 1-5151D-28

RUN DATE AND TIME: 15FEB90:16:03

SYSTEM NAME: EMERGENCY DIESEL GENERATOR "CD"

VALVE				VALVE POSITION				ASME SECTION XI						
NUMBER	REV	TYPE	SIZE	ACT TYPE	F.D. COORD	POWER OPER	SAFETY FUNC	CD ICL	A/P	CAT	PRIM TEST REQUIRED	TEST PERFORMED	TEST MODE	RELIEF REQUEST(S)
1-DG-101C	3	CK	1.5	SA	H/4	O	O/C	3	A	C	CF-1	CF-1	P	NO, NOTE 1
1-DG-103C	3	CK	1.5	SA	F/3	O	O/C	3	A	C	CF-1	CF-1	P	NO, NOTE 1
1-DG-127C	3	CK	1	SA	C/3	C	O	3	A	C	CF-1	CF-1	P	NO, NOTE 1
1-DG-129C	3	CK	1	SA	C/3	C	O	3	A	C	CF-1	CF-1	P	NO, NOTE 1
1-DG-139-CD	3	CK	0.5	SA	F/1	C	O/C	3	A	C	CF-1	CF-1	P	NO
1-DG-141-CD	3	CK	0.5	SA	F/1	C	O/C	3	A	C	CF-1	CF-1	P	NO
1-DG-145C	3	CK	2	SA	A/9	O	C	3	A	C	CF-1	CF-1	P	NO, NOTE 1
1-DG-151C	3	CK	4	SA	D/9	C	O	3	A	C	CF-1	CF-1	P	NO, NOTE 1
1-DG-153C	3	CK	4	SA	C/9	C	O	3	A	C	CF-1	CF-1	P	NO, NOTE 1
1-QT-132-1CD	3	3W	6	SA	E/8	O	O	3	A	B	EF-1	NOTE 2	P	NO, NOTE 2
1-SV-120-1CD	3	REL	0.25	SA	H/2	C	O	3	A	C	TF-1	TF-1	R	NO
1-SV-139-1CD	3	REL	1	SA	B/2	C	O	3	A	C	TF-1	TF-1	R	NO

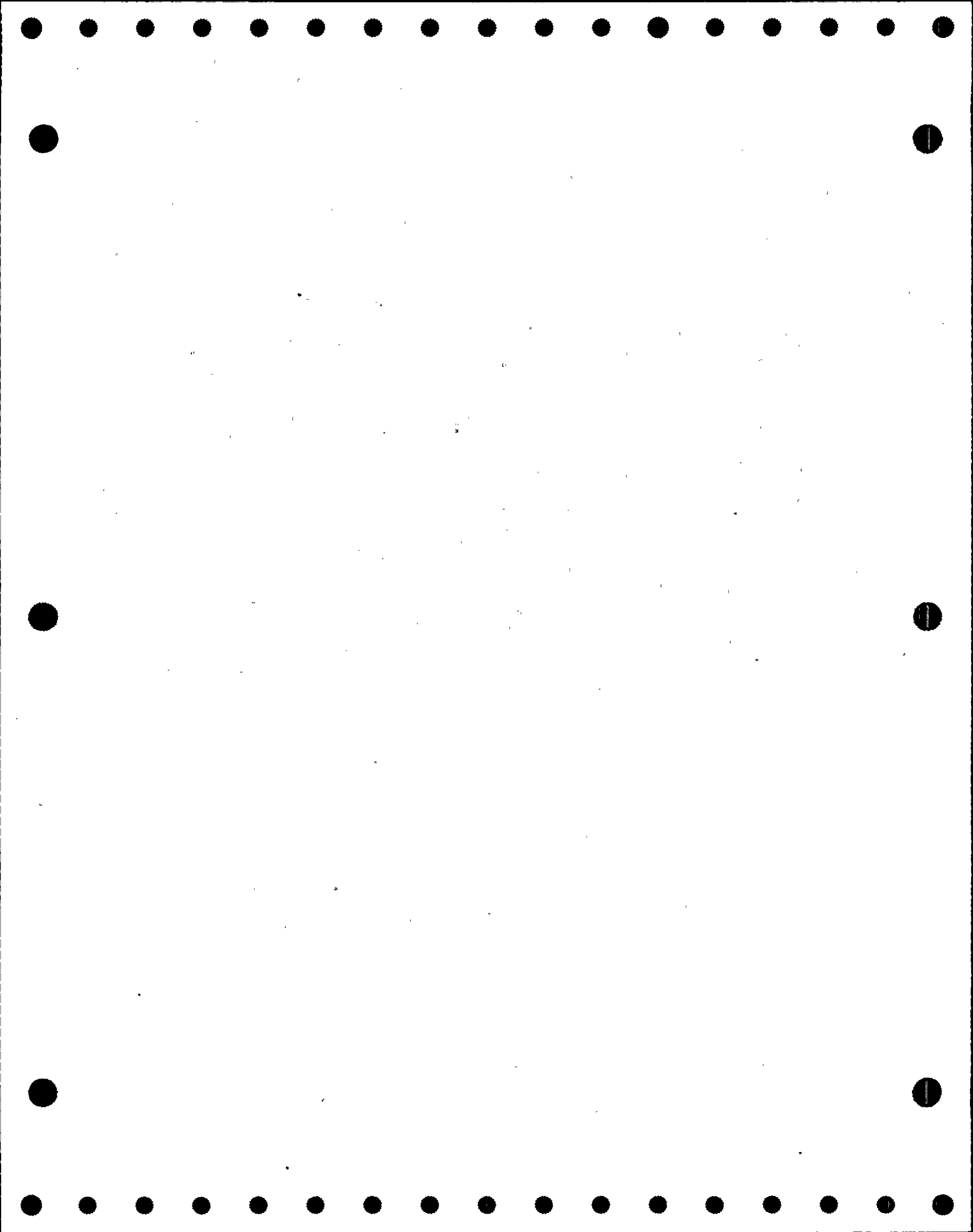

DONALD C. COOK NUCLEAR PLANT
 SECOND TEN YEAR INTERVAL
 VALVE SUMMARY SHEET - UNIT 1
 FLOW DIAGRAM: 1-5151D-28

RUN DATE AND TIME: 15FEB90:16:03

SYSTEM NAME: EMERGENCY DIESEL GENERATOR "CD"

VALVE				VALVE POSITION				ASME SECTION XI						
NUMBER	REV	TYPE	SIZE	ACT TYPE	F.D. COORD	POWER OPER	SAFETY FUNCT	CD ICL	A/P	CAT	PRIM TEST REQUIRED	TEST PERFORMED	TEST MODE	RELIEF REQUEST(S)
1-SV-61-1CD	3	REL	1	SA	A/8	C	0	3	A	C	TF-1	TF-1	R	NO
1-SV-78-1CD1	3	REL	1	SA	E/3	C	0	3	A	C	TF-1	TF-1	R	NO
1-SV-78-1CD2	3	REL	1	SA	D/3	C	0	3	A	C	TF-1	TF-1	R	NO
1-SV-79-1CD1	3	REL	0.5	SA	E/1	C	0	3	A	C	TF-1	TF-1	R	NO
1-SV-79-1CD2	3	REL	0.5	SA	E/1	C	0	3	A	C	TF-1	TF-1	R	NO
1-XRV-225	3	GA	1	A	B/3	C	0	3	A	B	EF-1 EF-7 ET-XXX	EF-1 EF-7 NOTE 4	- - -	YES, NOTE 4 YES, NOTE 4 YES, NOTE 4
1-XRV-226	3	GL	3	A	B/4	C	0	3	A	B	EF-1 EF-7 ET-XXX	EF-1 NOTE 3 NOTE 3	- - -	YES, NOTE 3 YES, NOTE 3 YES, NOTE 3
1-XRV-227	3	GL	3	A	B/4	C	0	3	A	B	EF-1 EF-7 ET-XXX	EF-1 NOTE 3 NOTE 3	- - -	YES, NOTE 3 YES, NOTE 3 YES, NOTE 3

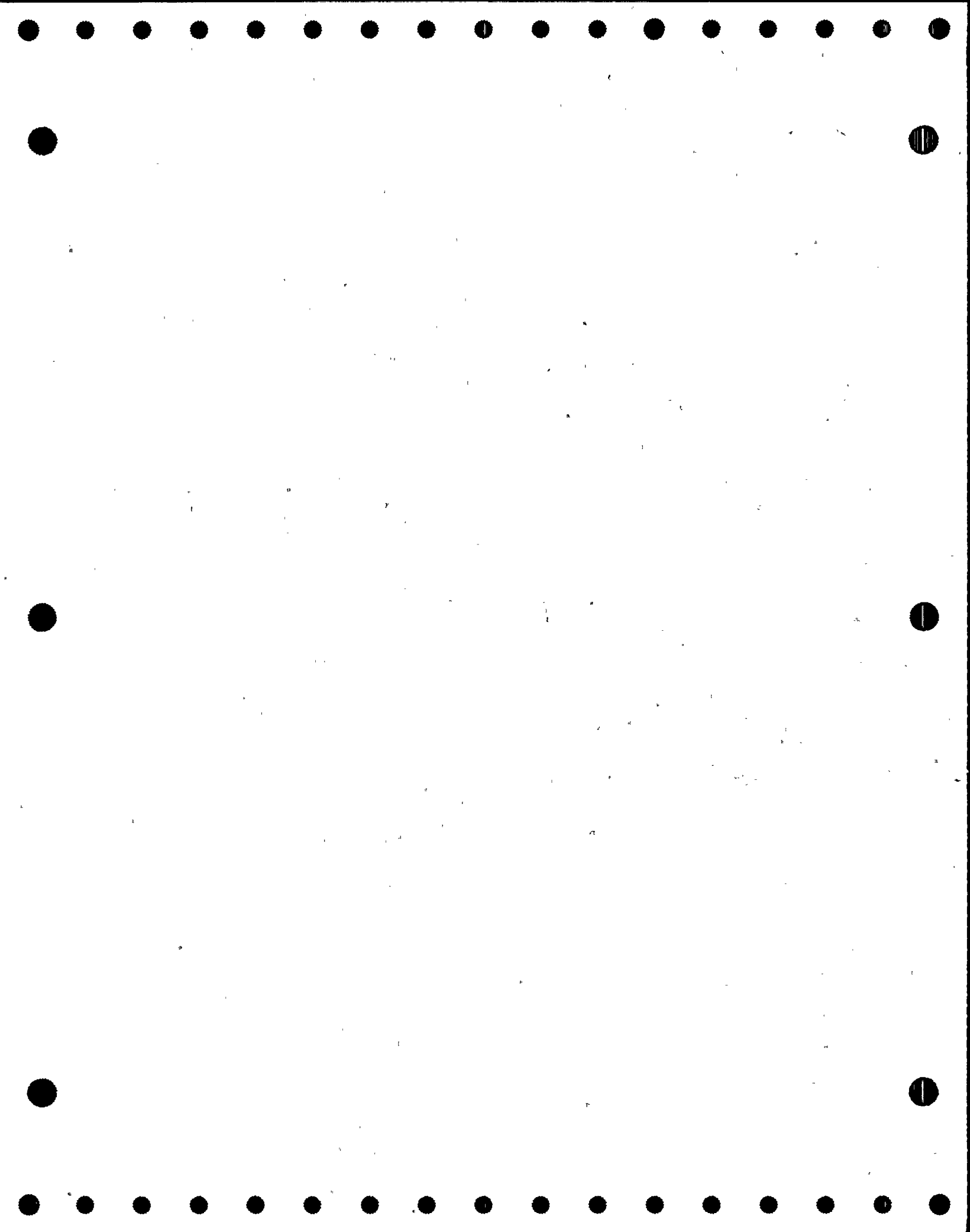

DONALD C. COOK NUCLEAR PLANT
 SECOND TEN YEAR INTERVAL
 VALVE SUMMARY SHEET - UNIT 1
 FLOW DIAGRAM: 12-5115A-41

RUN DATE AND TIME: 15FEB90:16:03

SYSTEM NAME: MAKE UP & PRIMARY WATER UNIT 1

VALVE		VALVE POSITION			ASME SECTION XI									
NUMBER	REV	TYPE	SIZE	ACT TYPE	F.D. COORD	POWER OPER	SAFETY FUNCT	CD ICL	A/P	CAT	PRIM TEST REQUIRED	TEST PERFORMED	TEST MODE	RELIEF REQUEST(S)
1-QCR-919	3	DA	2	A	D/7	O/C	C	2	A	A	EF-1	EF-1	P	NO
											EF-5	EF-5	-	NO
											EF-7	EF-7	P	NO
											ET-XXX	ET-XXX	P	NO
											SLT-1	SLT-2	R	YES, NOTE 1
1-QCR-920	3	DA	2	A	D/7	O/C	C	2	A	A	EF-1	EF-1	P	NO
											EF-5	EF-5	-	NO
											EF-7	EF-7	P	NO
											ET-XXX	ET-XXX	P	NO
											SLT-1	SLT-2	R	YES, NOTE 1

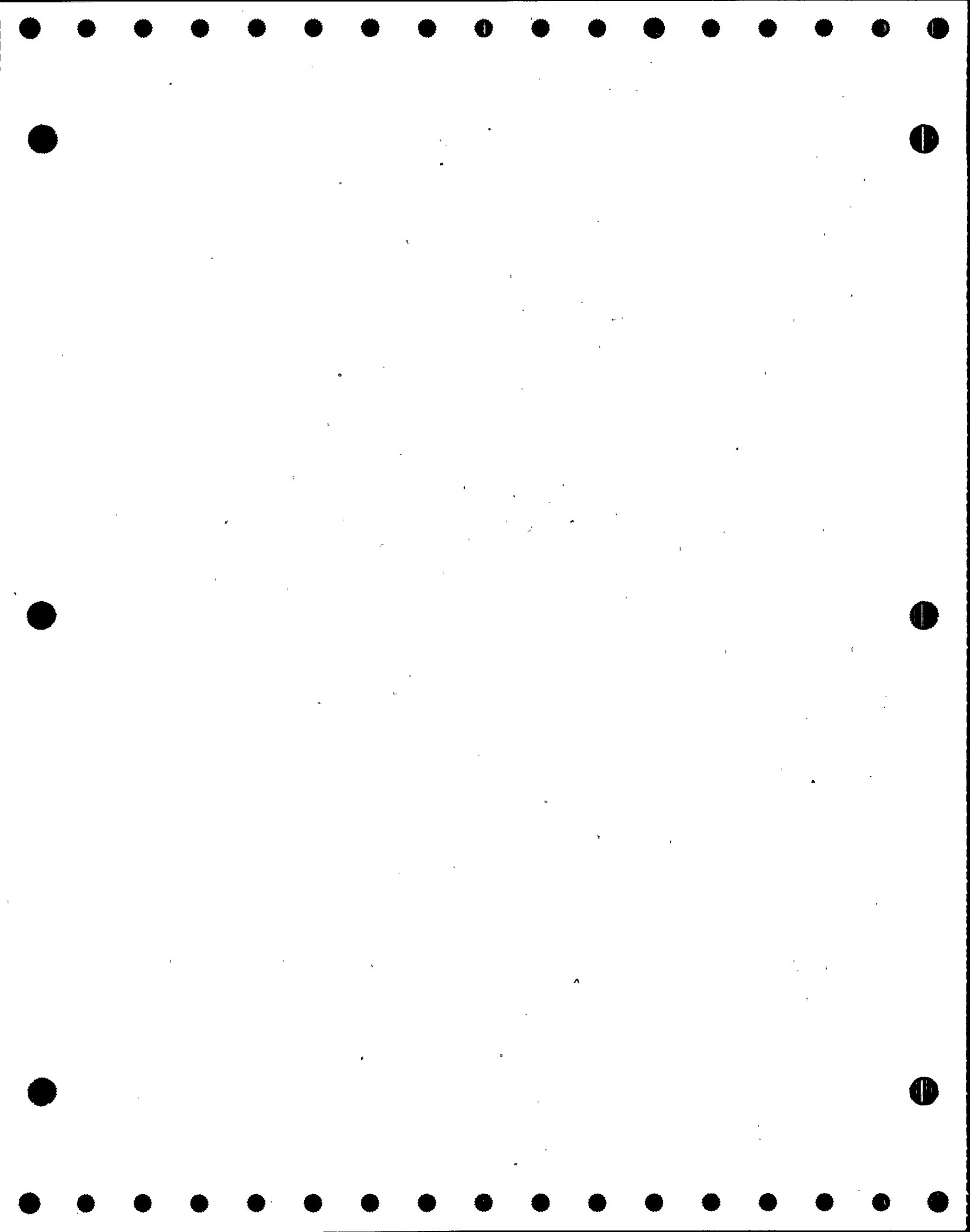

DONALD C. COOK NUCLEAR PLANT
 SECOND TEN YEAR INTERVAL
 VALVE SUMMARY SHEET - UNIT 1
 FLOW DIAGRAM: 12-5120B-22

RUN DATE AND TIME: 15FEB90:16:03

SYSTEM NAME: COMPRESSED AIR SYSTEM UNIT 1

VALVE				VALVE POSITION				ASME SECTION XI						
NUMBER	REV	TYPE	SIZE	ACT TYPE	F.D. COORD	POWER OPER	SAFETY FUNCT	CD ICL	A/P	CAT	PRIM TEST REQUIRED	TEST PERFORMED	TEST MODE	RELIEF REQUEST(S)
1-PA-343	3	CK	2	SA	B/7	O/C	C	2	A	AC	CF-1 SLT-1	CF-2 SLT-2	R R	YES, NOTE 1 YES, NOTE 2
1-PCR-40	3	GA	2	A	D/7	O/C	C	2	A	A	EF-1 EF-5 EF-7 ET-XXX SLT-1	EF-1 EF-5 EF-7 ET-XX SLT-2	P - P P R	NO NO NO NO YES, NOTE 2
1-XCR-100	3	GL	1	A	L/3	O	C	2	A	A	EF-1 EF-5 EF-7 ET-XXX SLT-1	EF-2 EF-5 EF-8 ET-XXX SLT-2	C - C C R	NO, CSJ 3 NO NO, CSJ 3 NO, CSJ 3 YES, NOTE 2
1-XCR-101	3	GL	1	A	L/3	O	C	2	A	A	EF-1 EF-5 EF-7 ET-XXX SLT-1	EF-2 EF-5 EF-8 ET-XXX SLT-2	C - C C R	NO, CSJ 3 NO NO, CSJ 3 NO, CSJ 3 YES, NOTE 2
1-XCR-102	3	GL	1	A	L/2	O	C	2	A	A	EF-1 EF-5 EF-7 ET-XXX SLT-1	EF-2 EF-5 EF-8 ET-XXX SLT-2	C - C C R	NO, CSJ 3 NO NO, CSJ 3 NO, CSJ 3 YES, NOTE 2
1-XCR-103	3	GL	1	A	L/2	O	C	2	A	A	EF-1 EF-5 EF-7 ET-XXX SLT-1	EF-2 EF-5 EF-8 ET-XXX SLT-2	C - C C R	NO, CSJ 3 NO NO, CSJ 3 NO, CSJ 3 YES, NOTE 2

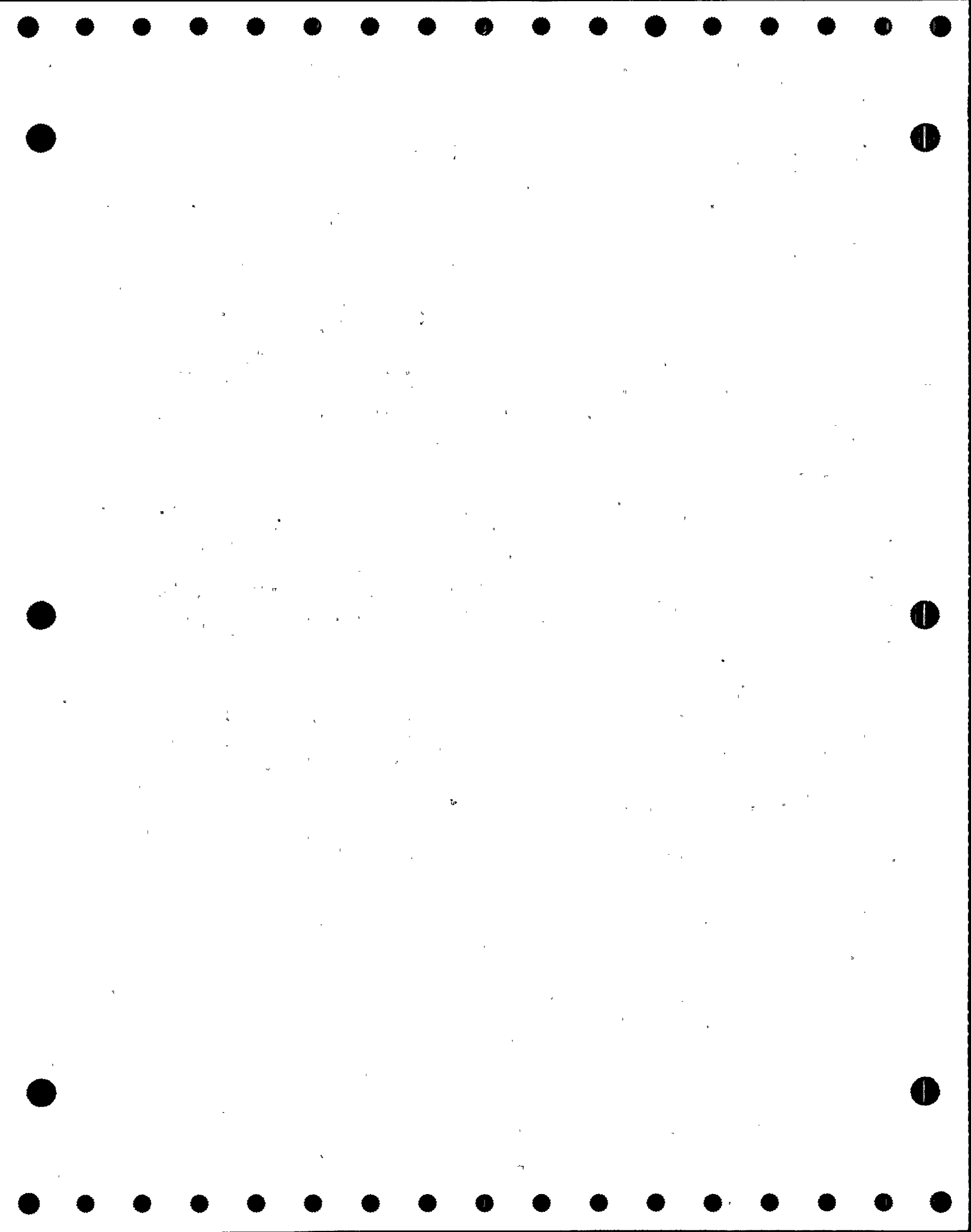

DONALD C. COOK NUCLEAR PLANT
 SECOND TEN YEAR INTERVAL
 VALVE SUMMARY SHEET - UNIT 1
 FLOW DIAGRAM: 12-5131-19

RUN DATE AND TIME: 15FEB90:16:03

SYSTEM NAME: CVCS - BORON MAKE-UP - UNITS 1 & 2

VALVE				VALVE POSITION				ASME SECTION XI							
NUMBER	REV	TYPE	SIZE	ACT TYPE	F.D. COORD	POWER OPER	SAFETY FUNCT	CD ICL	A/P	CAT	PRIM TEST REQUIRED	TEST PERFORMED	TEST MODE	RELIEF REQUEST(S)	
1-CS-415-1	3	CK	2	SA	H/6	O/C	0	3	A	C	CF-1	CF-1	P	NO	
1-CS-415-2	3	CK	2	SA	H/6	O/C	0	3	A	C	CF-1	CF-1	P	NO	
1-CS-426-N	3	CK	1	SA	G/6	O/C	0	3	A	C	CF-1	CF-1	P	NO	
1-CS-427-N	3	CK	2	SA	G/5	C	0	3	A	C	CF-1	CF-2	C	NO, CSJ 1	
1-QMO-410	3	GL	2	MO	G/5	C	0	3	A	B	EF-1 EF-5 ET-XXX	EF-1 EF-5 ET-XXX	P - P	NO NO NO	
1-QRV-411	3	GL	1	A	G/6	O/C	0	3	A	B	EF-1 EF-5 EF-7 ET-XXX	EF-1 EF-5 EF-7 ET-XXX	P - P P	NO NO NO NO	
1-QRV-412	3	GL	2	A	F/7	O	C	3	A	B	EF-1 EF-5 EF-7 ET-XXX	EF-1 EF-5 EF-7 ET-XXX	P - P P	NO NO NO NO	

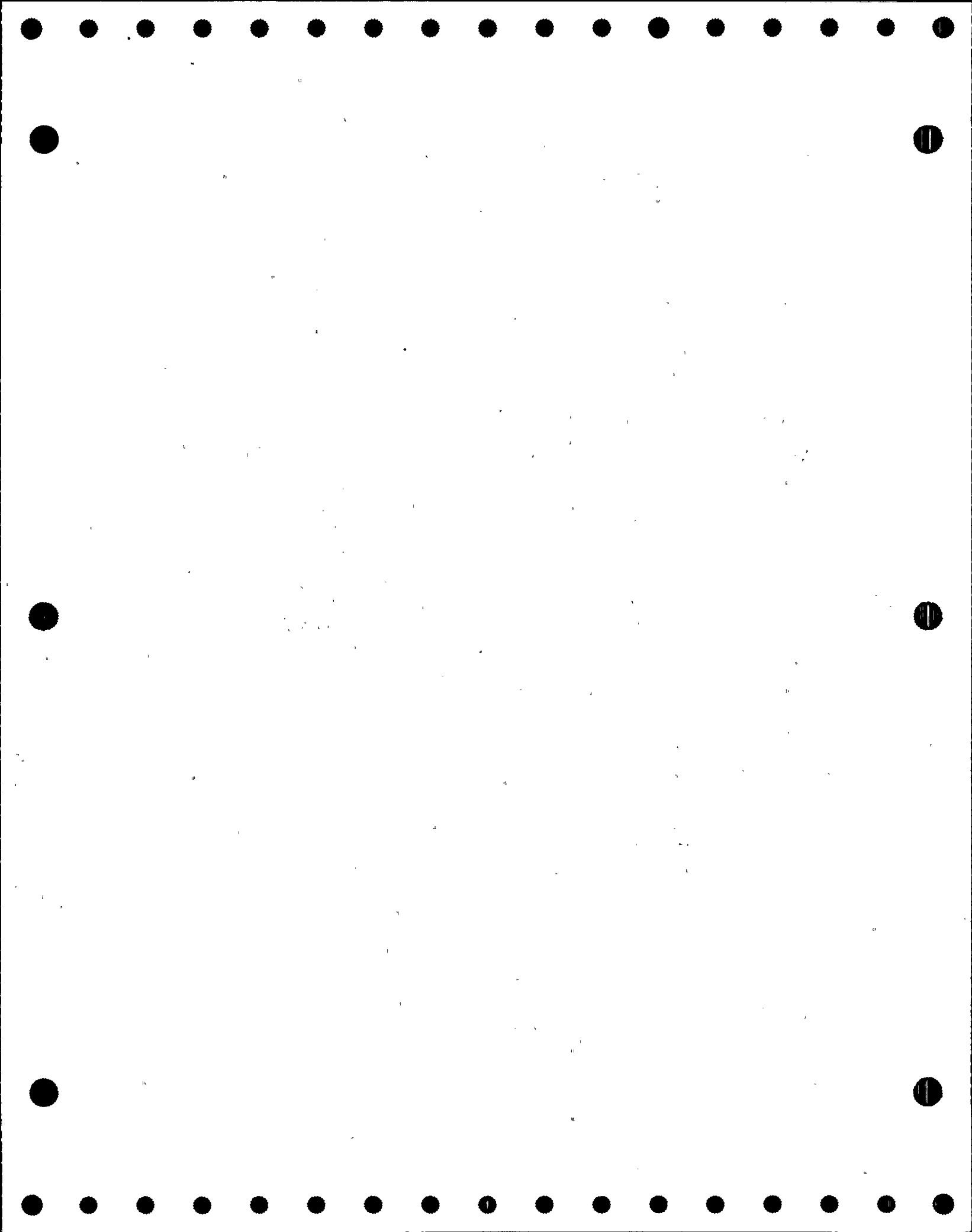

DONALD C. COOK NUCLEAR PLANT
 SECOND TEN YEAR INTERVAL
 VALVE SUMMARY SHEET - UNIT 1
 FLOW DIAGRAM: 12-5136-25

RUN DATE AND TIME: 15FEB90:16:03

SYSTEM NAME: SPENT FUEL PIT COOLING & CLEANUP U1

VALVE				VALVE POSITION				ASME SECTION XI						
NUMBER	REV	TYPE	SIZE	ACT TYPE	F.D. COORD	POWER OPER	SAFETY FUNCT	CD ICL	A/P	CAT	PRIM TEST REQUIRED	TEST PERFORMED	TEST MODE	RELIEF REQUEST(S)
1-SF-151	3	DA	2.5	M	K/8	C	C	2	P	A	SLT-1	SLT-2	R	YES, NOTE 1
1-SF-153	3	GL	2.5	M	K/8	C	C	2	P	A	SLT-1	SLT-2	R	YES, NOTE 1
12-SF-118N	3	CK	8	SA	J/5	O/C	O	3	A	C	CF-1	CF-1	P	NO
12-SF-118S	3	CK	8	SA	J/5	O/C	O	3	A	C	CF-1	CF-1	P	NO

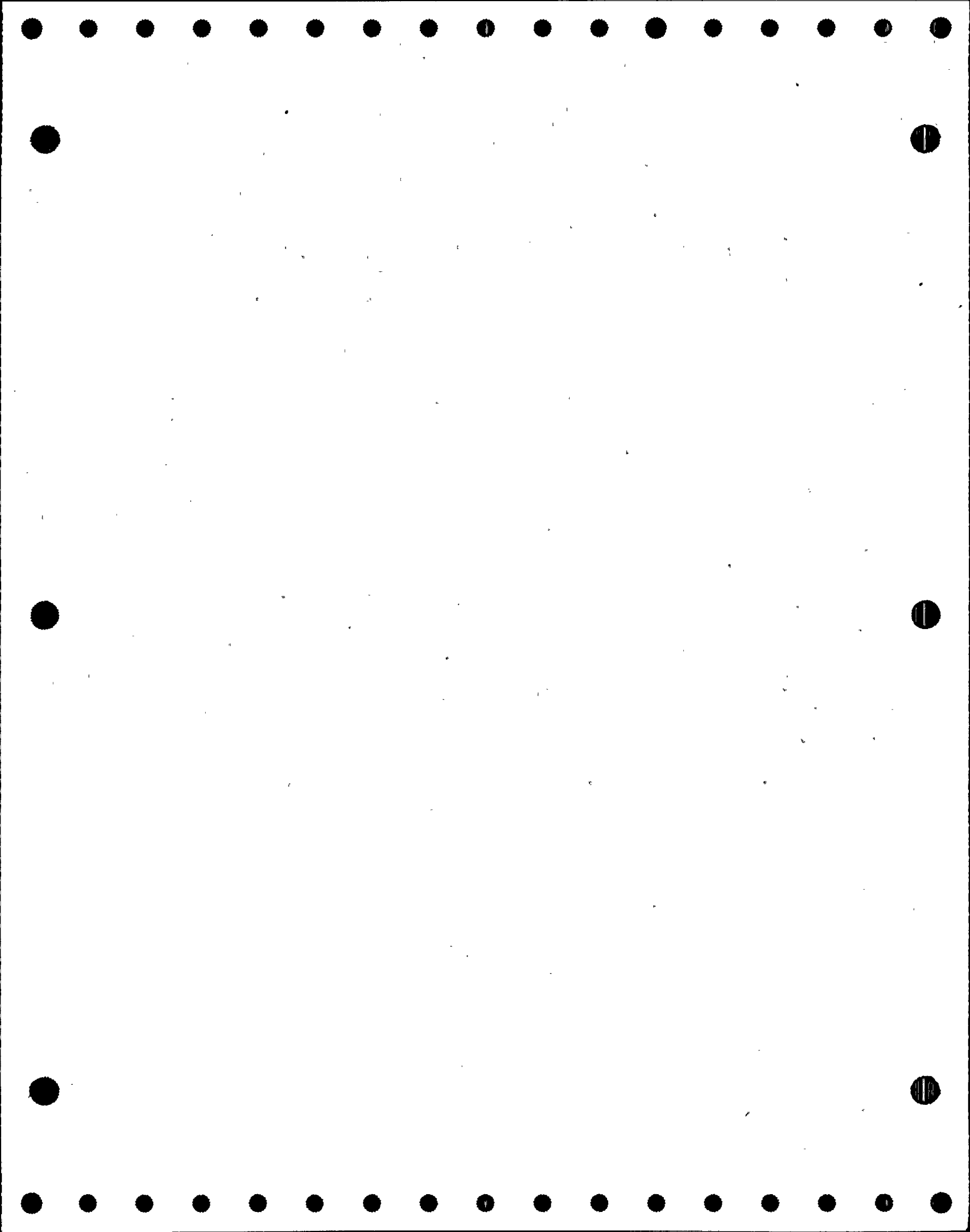

DONALD C. COOK NUCLEAR PLANT
 SECOND TEN YEAR INTERVAL
 VALVE SUMMARY SHEET - UNIT 1
 FLOW DIAGRAM: 12-5137A-21

RUN DATE AND TIME: 15FEB90:16:03

SYSTEM NAME: WDS VENTS & DRAINS

VALVE				VALVE POSITION				ASME SECTION XI						
NUMBER	REV	TYPE	SIZE	ACT TYPE	F.D. COORD	POWER OPER	SAFETY FUNCT	CD ICL	A/P	CAT	PRIM TEST REQUIRED	TEST PERFORMED	TEST MODE	RELIEF REQUEST(S)
1-DCR-201	3	DA	1	A	E/4	C	C	2	P	A	EF-1	EF-1	P	NO
											EF-5	EF-5	-	NO
											EF-7	EF-7	P	NO
											ET-XXX	ET-XXX	P	NO
											SLT-1	SLT-2	R	YES, NOTE 1
1-DCR-202	3	DA	0.75	A	E/5	O	C	2	A	A	EF-1	EF-1	P	NO
											EF-5	EF-5	-	NO
											EF-7	EF-7	P	NO
											ET-XXX	ET-XXX	P	NO
											SLT-1	SLT-2	R	YES, NOTE 1
1-DCR-203	3	DA	1	A	F/4	C	C	2	P	A	EF-1	EF-1	P	NO
											EF-5	EF-5	-	NO
											EF-7	EF-7	P	NO
											ET-XXX	ET-XXX	P	NO
											SLT-1	SLT-2	R	YES, NOTE 1
1-DCR-204	3	DA	0.75	A	F/5	O	C	2	A	A	EF-1	EF-1	P	NO
											EF-5	EF-5	-	NO
											EF-7	EF-7	P	NO
											ET-XXX	ET-XXX	P	NO
											SLT-1	SLT-2	R	YES, NOTE 1
1-DCR-205	3	GL	4	A	E/7	O/C	C	2	A	A	EF-1	EF-1	P	NO
											EF-5	EF-5	-	NO
											EF-7	EF-7	P	NO
											ET-XXX	ET-XXX	P	NO
											SLT-1	SLT-2	R	YES, NOTE 1

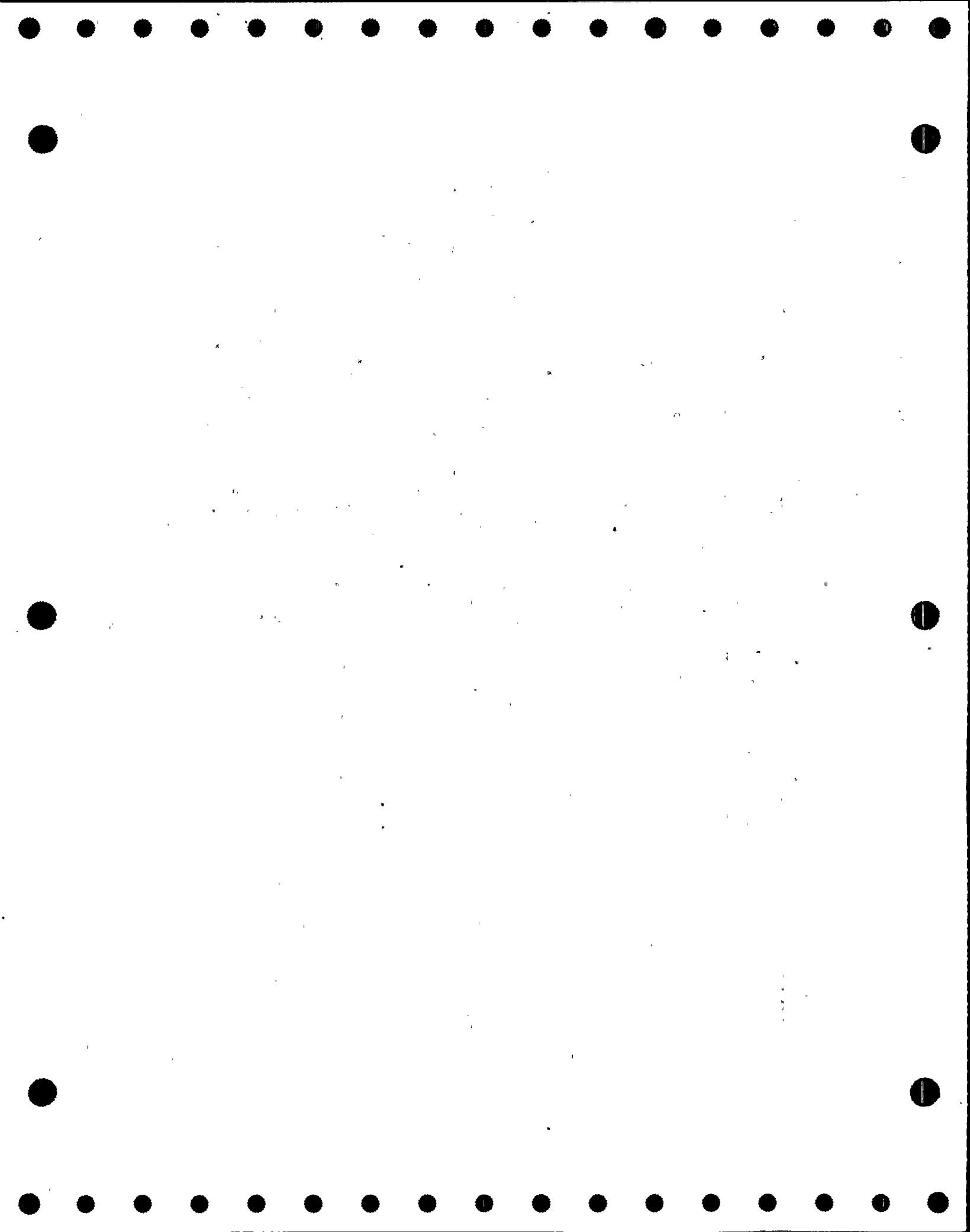

DONALD C. COOK NUCLEAR PLANT
 SECOND TEN YEAR INTERVAL
 VALVE SUMMARY SHEET - UNIT 1
 FLOW DIAGRAM: 12-5137A-21

RUN DATE AND TIME: 15FEB90:16:03

SYSTEM NAME: WDS VENTS & DRAINS

VALVE				VALVE POSITION				ASME SECTION XI						
NUMBER	REV	TYPE	SIZE	ACT TYPE	F.D. COORD	POWER OPER	SAFETY FUNCT	CD ICL	A/P	CAT	PRIM TEST REQUIRED	TEST PERFORMED	TEST MODE	RELIEF REQUEST(S)
1-DCR-206	3	GL	4	A	E/8	O/C	C	2	A	A	EF-1	EF-1	P	NO
											EF-5	EF-5	-	NO
											EF-7	EF-7	P	NO
											ET-XXX	ET-XXX	P	NO
											SLT-1	SLT-2	R	YES, NOTE 1
1-DCR-207	3	DA	1	A	F/4	O	C	2	A	A	EF-1	EF-1	P	NO
											EF-5	EF-5	-	NO
											EF-7	EF-7	P	NO
											ET-XXX	ET-XXX	P	NO
											SLT-1	SLT-2	R	YES, NOTE 1
1-DCR-610	3	DA	2.5	A	M/9	O	C	2	A	A	EF-1	EF-1	P	NO
											EF-5	EF-5	-	NO
											EF-7	EF-7	P	NO
											ET-XXX	ET-XXX	P	NO
											SLT-1	SLT-2	R	YES, NOTE 1
1-DCR-611	3	DA	2.5	A	N/9	O	C	2	A	A	EF-1	EF-1	P	NO
											EF-5	EF-5	-	NO
											EF-7	EF-7	P	NO
											ET-XXX	ET-XXX	P	NO
											SLT-1	SLT-2	R	YES, NOTE 1
1-DCR-620	3	DA	1	A	M/9	O	C	2	A	A	EF-1	EF-1	P	NO
											EF-5	EF-5	-	NO
											EF-7	EF-7	P	NO
											ET-XXX	ET-XXX	P	NO
											SLT-1	SLT-2	R	YES, NOTE 1

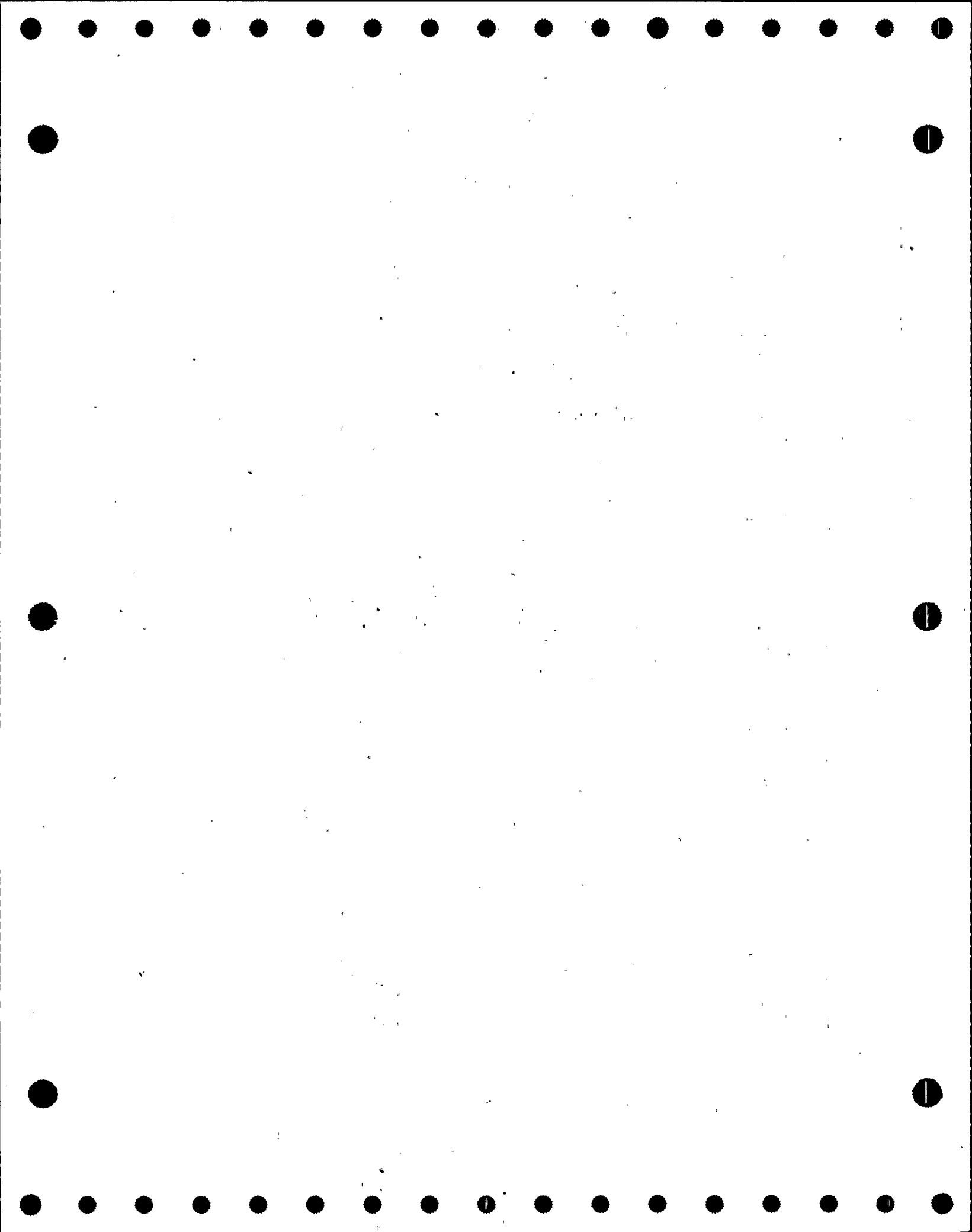

DONALD C. COOK NUCLEAR PLANT
 SECOND TEN YEAR INTERVAL
 VALVE SUMMARY SHEET - UNIT 1
 FLOW DIAGRAM: 12-5137A-21

RUN DATE AND TIME: 15FEB90:16:03

SYSTEM NAME: WDS VENTS & DRAINS

VALVE				VALVE POSITION				ASME SECTION XI						
NUMBER	REV	TYPE	SIZE	ACT TYPE	F.D. COORD	POWER OPER	SAFETY FUNCT	CD ICL	A/P	CAT	PRIM TEST REQUIRED	TEST PERFORMED	TEST MODE	RELIEF REQUEST(S)
1-DCR-621	3	DA	1	A	N/9	O	C	2	A	A	EF-1 EF-5 EF-7 ET-XXX SLT-1	EF-1 EF-5 EF-7 ET-XXX SLT-2	P - P P R	NO NO NO NO YES, NOTE 1
1-N-160	3	CK	1	SA	F/4	O	C	2	A	AC	CF-1 SLT-1	CF-2 SLT-2	R R	YES, NOTE 2 YES, NOTE 1
1-SF-159	3	DA	3	M	E/5	C	C	2	P	A	SLT-1	SLT-2	R	YES, NOTE 1
1-SF-160	3	DA	3	M	F/5	C	C	2	P	A	SLT-1	SLT-2	R	YES, NOTE 1

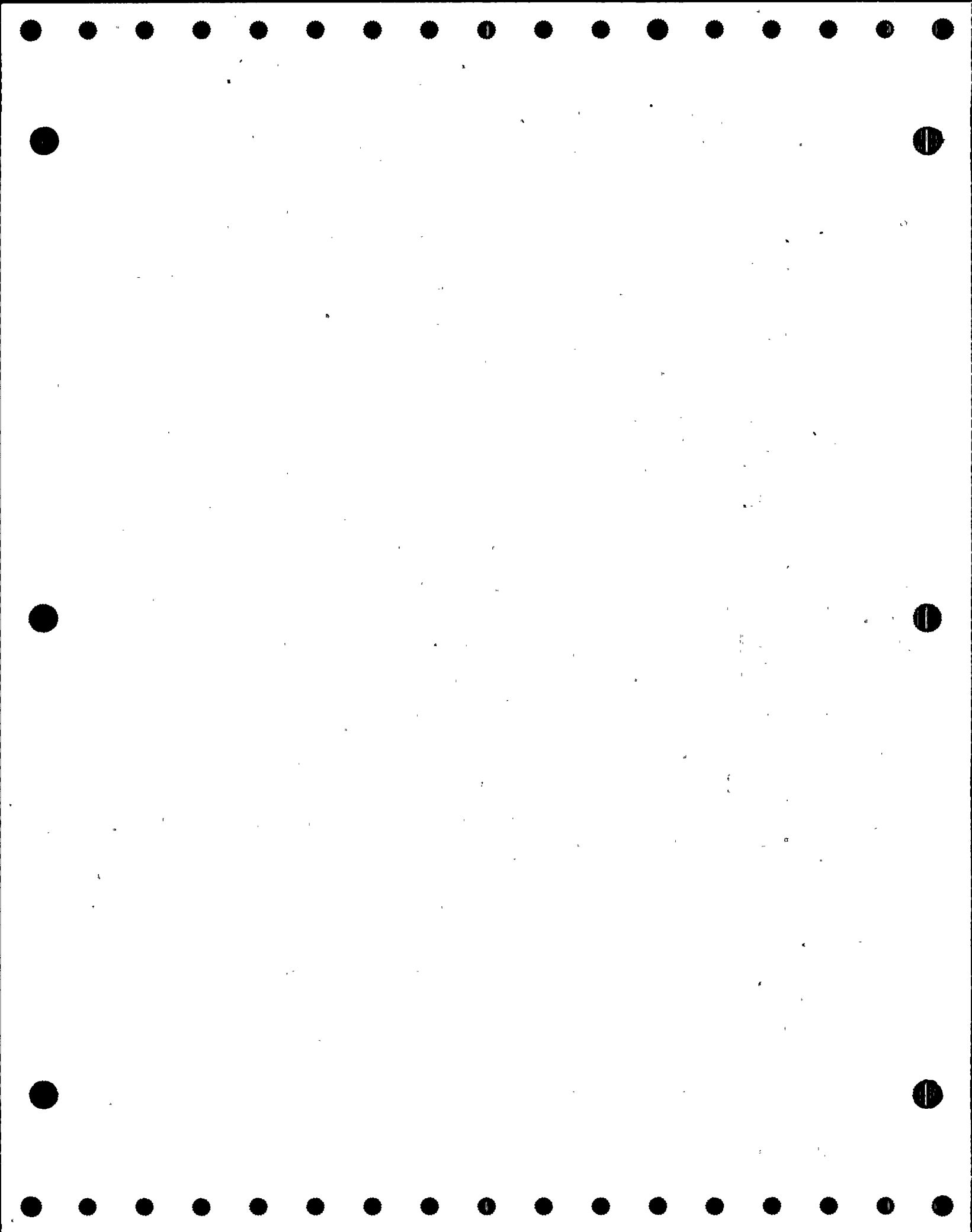

DONALD C. COOK NUCLEAR PLANT
 SECOND TEN YEAR INTERVAL
 VALVE SUMMARY SHEET - UNIT 1
 FLOW DIAGRAM: 12-5141C-8

RUN DATE AND TIME: 15FEB90:16:03

SYSTEM NAME: PAS LIQUID & GAS - UNIT-1

VALVE				VALVE POSITION				ASME SECTION XI						
NUMBER	REV	TYPE	SIZE	ACT TYPE	F.D. COORD	POWER OPER	SAFETY FUNCT	CD ICL	A/P	CAT	PRIM TEST REQUIRED	TEST PERFORMED	TEST MODE	RELIEF REQUEST(S)
1-ECR-416	3	GL	0.5	A	B/6	C	C	2	P	A	EF-1	EF-1	P	NO
											EF-5	EF-5	-	NO
											EF-7	EF-7	P	NO
											ET-XXX	ET-XXX	P	NO
											SLT-1	SLT-2	R	YES, NOTE 1
1-ECR-417	3	GL	0.5	A	B/6	C	C	2	P	A	EF-1	EF-1	P	NO
											EF-5	EF-5	-	NO
											EF-7	EF-7	P	NO
											ET-XXX	ET-XXX	P	NO
											SLT-1	SLT-2	R	YES, NOTE 1
1-ECR-496	3	GL	0.5	A	B/8	C	C	2	P	A	EF-1	EF-1	P	NO
											EF-5	EF-5	-	NO
											EF-7	EF-7	P	NO
											ET-XXX	ET-XXX	P	NO
											SLT-1	SLT-2	R	YES, NOTE 1
1-ECR-497	3	GL	0.5	A	B/8	C	C	2	P	A	EF-1	EF-1	P	NO
											EF-5	EF-5	-	NO
											EF-7	EF-7	P	NO
											ET-XXX	ET-XXX	P	NO
											SLT-1	SLT-2	R	YES, NOTE 1
1-ECR-535	3	GL	0.5	A	B/2	C	C	2	P	A	EF-1	EF-1	P	NO
											EF-5	EF-5	-	NO
											EF-7	EF-7	P	NO
											ET-XXX	ET-XXX	P	NO
											SLT-1	SLT-2	R	YES, NOTE 1

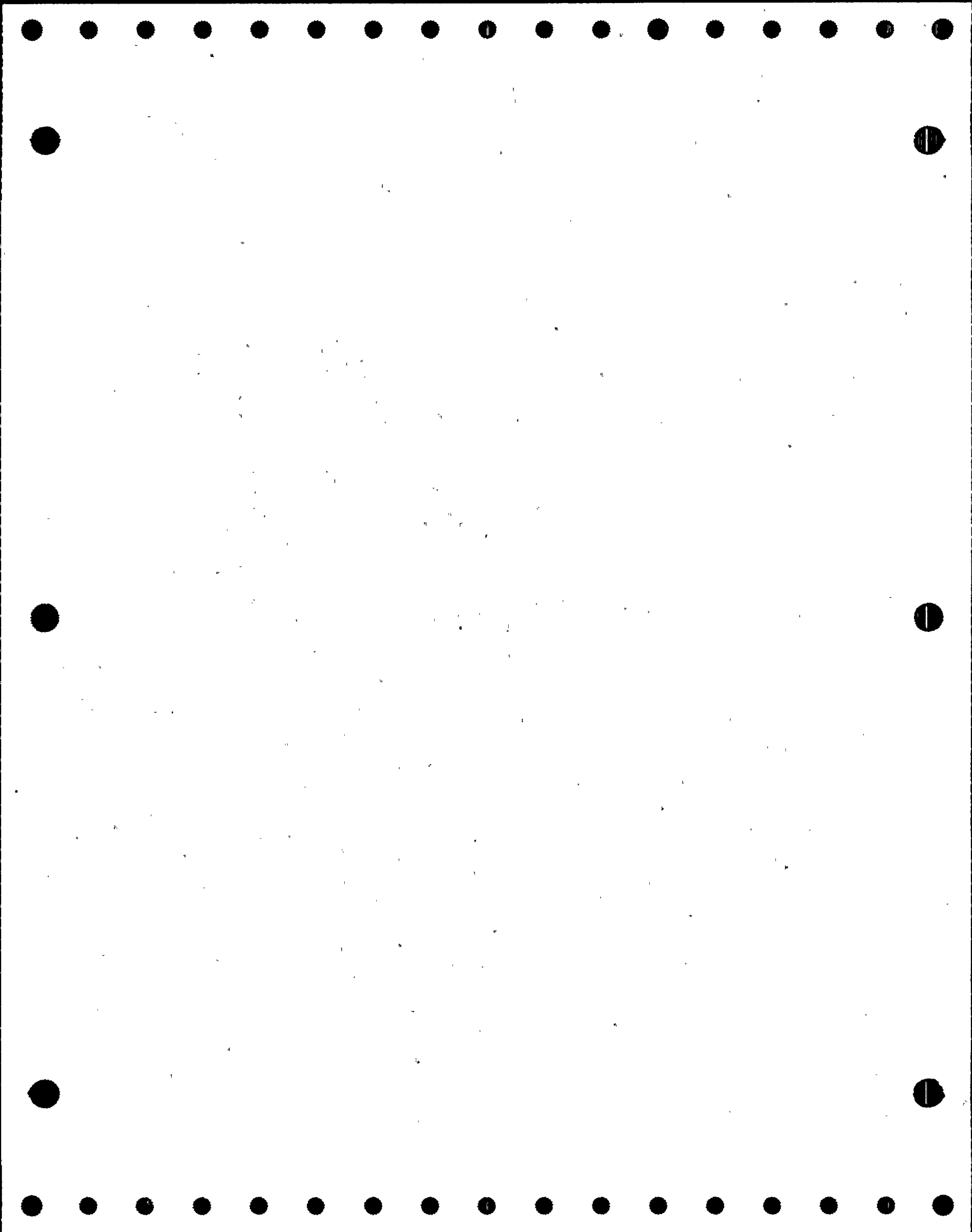

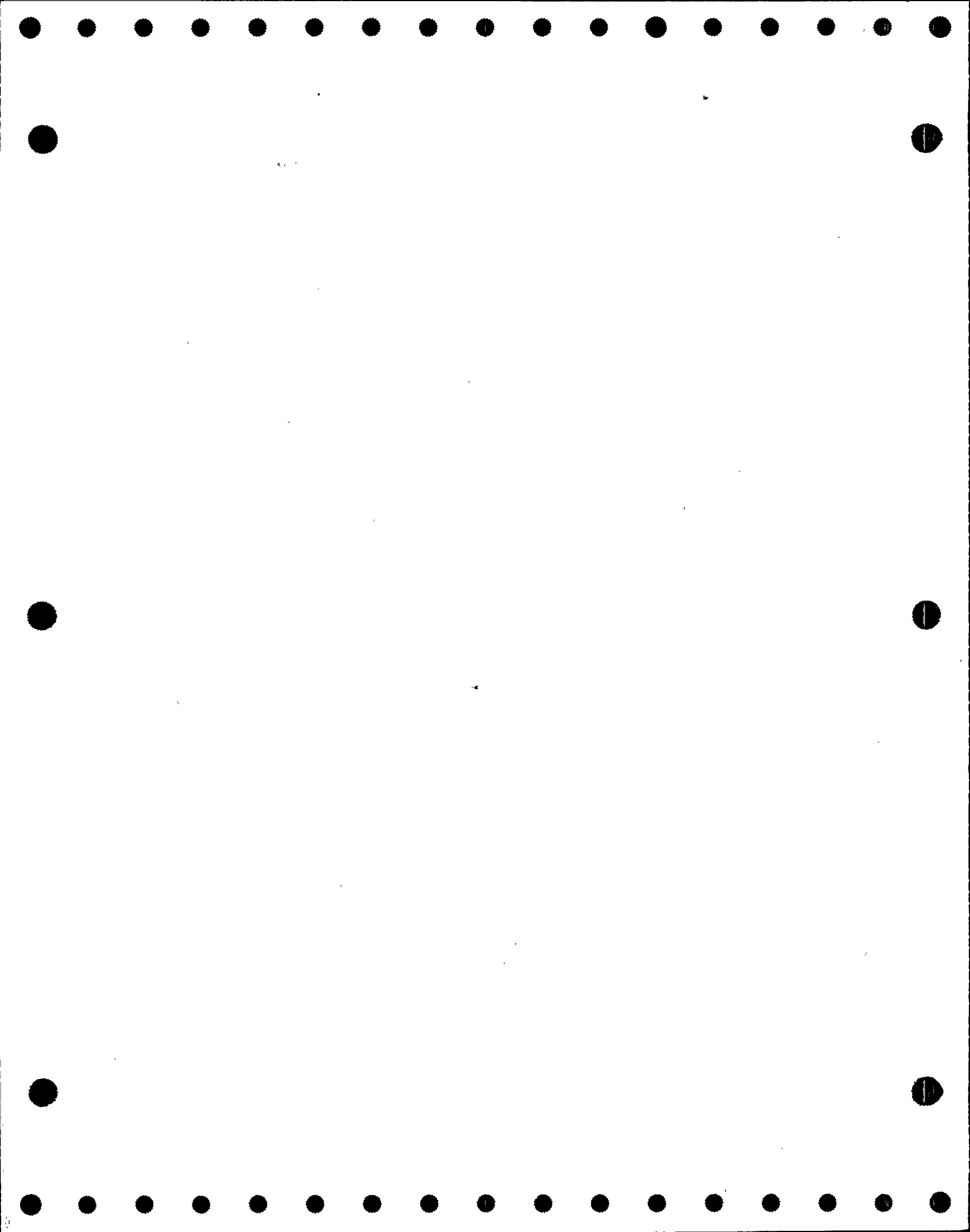

DONALD C. COOK NUCLEAR PLANT
 SECOND TEN YEAR INTERVAL
 VALVE SUMMARY SHEET - UNIT 1
 FLOW DIAGRAM: 12-5141F-6

RUN DATE AND TIME: 15FEB90:16:03

SYSTEM NAME: PAL SAMPLING & INST. PANELS - U-1

VALVE		VALVE POSITION				ASME SECTION XI									
NUMBER	REV	TYPE	SIZE	ACT TYPE	F.D. COORD	POWER OPER	SAFETY FUNCT	CD ICL	A/P	CAT	PRIM TEST REQUIRED	TEST PERFORMED	TEST MODE	RELIEF REQUEST(S)	
1-ECR-31	3	GL	1	A	B/5	0	C	2	A	A	EF-1	EF-1	P	NO	
											EF-5	EF-5	-	NO	
											EF-7	EF-7	P	NO	
											ET-XXX	ET-XXX	P	NO	
											SLT-1	SLT-2	R	YES, NOTE 2	
1-ECR-32	3	GL	1	A	B/5	0	C	2	A	A	EF-1	EF-1	P	NO	
											EF-5	EF-5	-	NO	
											EF-7	EF-7	P	NO	
											ET-XXX	ET-XXX	P	NO	
											SLT-1	SLT-2	R	YES, NOTE 2	
1-ECR-33	3	GL	0.75	A	B/5	0	C	2	A	A	EF-1	EF-1	P	NO	
											EF-5	EF-5	-	NO	
											EF-7	EF-7	P	NO	
											ET-XXX	ET-XXX	P	NO	
											SLT-1	SLT-2	R	YES, NOTE 2	
1-ECR-35	3	GL	1	A	B/5	0	C	2	A	A	EF-1	EF-1	P	NO	
											EF-5	EF-5	-	NO	
											EF-7	EF-7	P	NO	
											ET-XXX	ET-XXX	P	NO	
											SLT-1	SLT-2	R	YES, NOTE 2	
1-ECR-36	3	GL	1	A	B/6	0	C	2	A	A	EF-1	EF-2	C	NO, CSJ 1	
											EF-5	EF-5	-	NO	
											EF-7	EF-8	C	NO, CSJ 1	
											ET-XXX	ET-XXX	C	NO, CSJ 1	
											SLT-1	SLT-2	R	YES, NOTE 2	

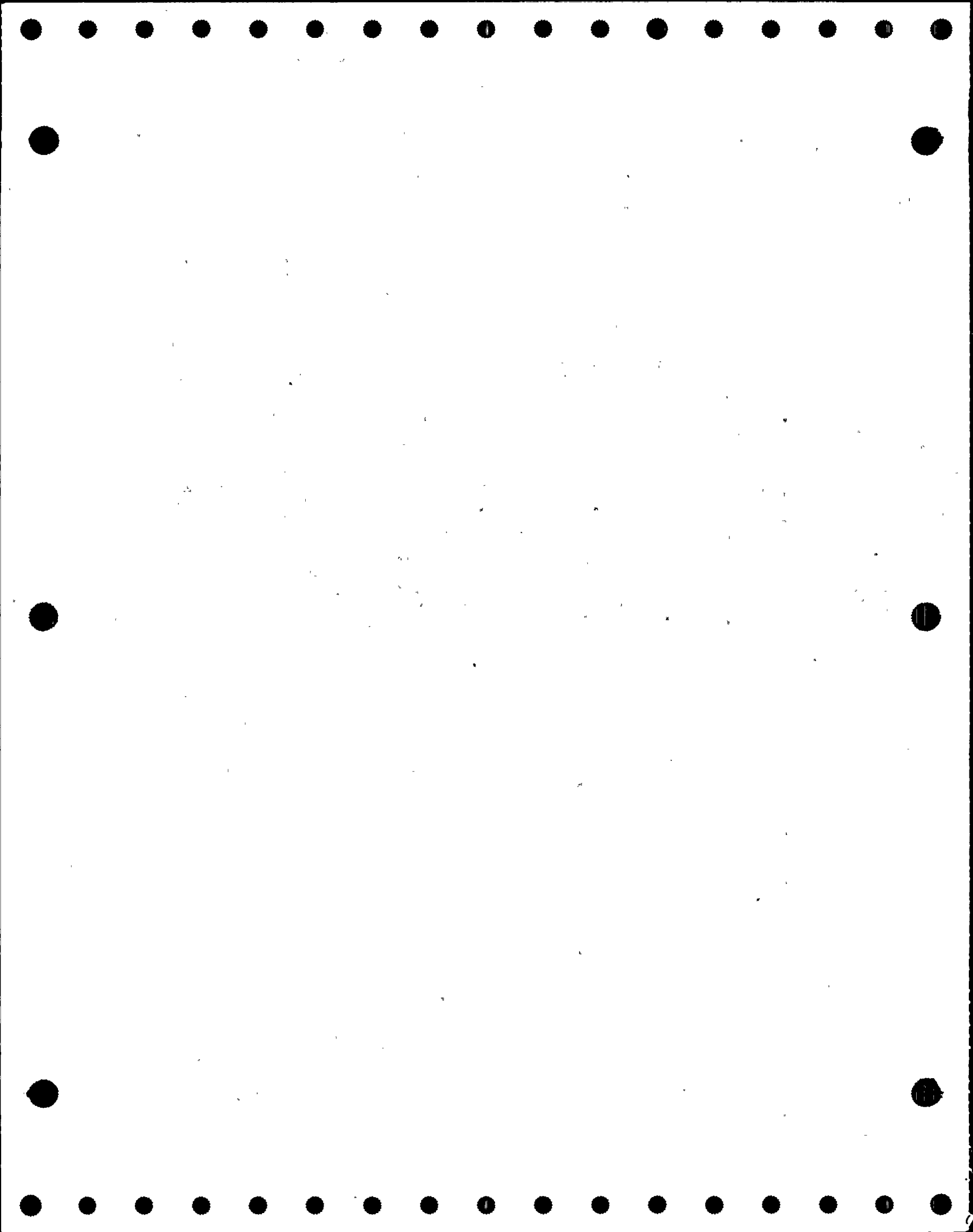

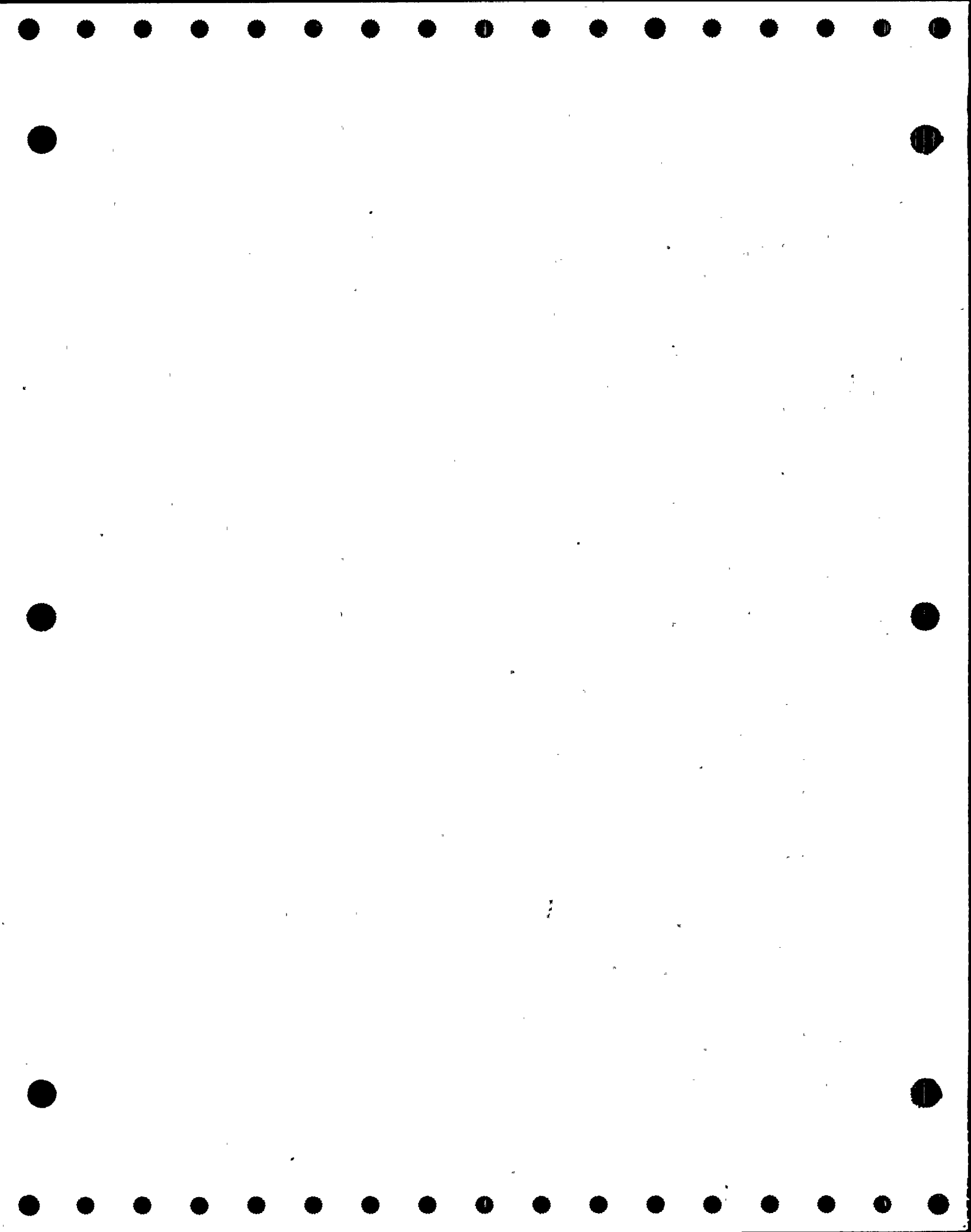

A B C D E F G H I J K L M O

5015-1 (CON 2)

"NOT FOR D. C. COOK OPERATIONAL USE"

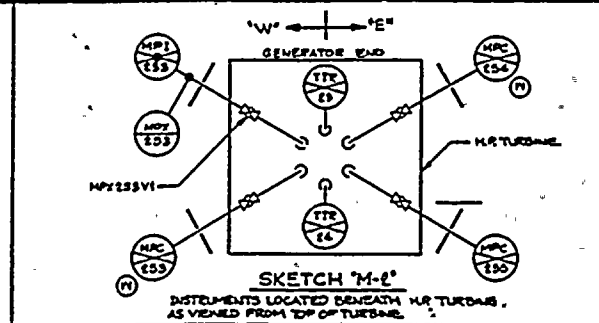
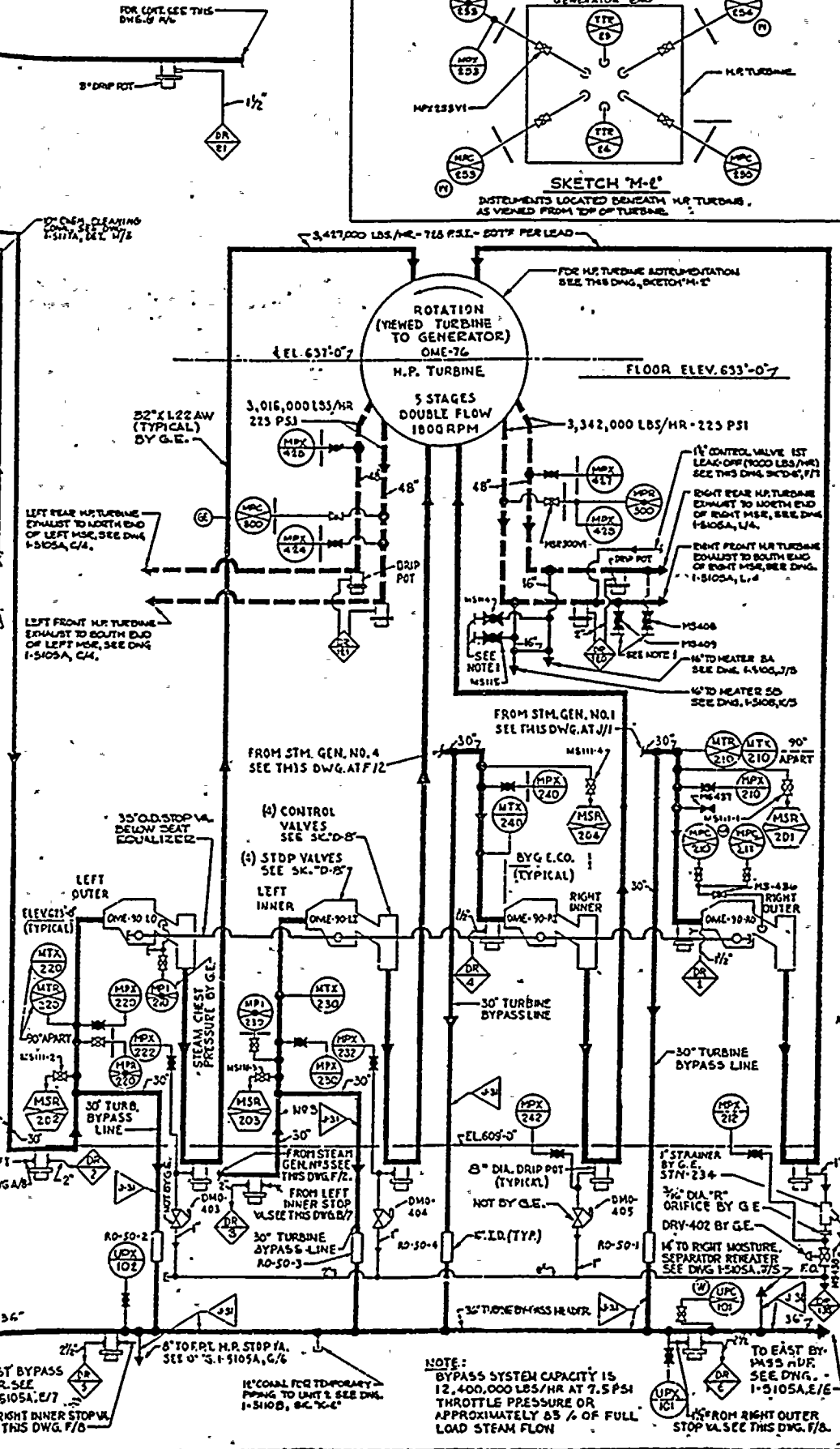
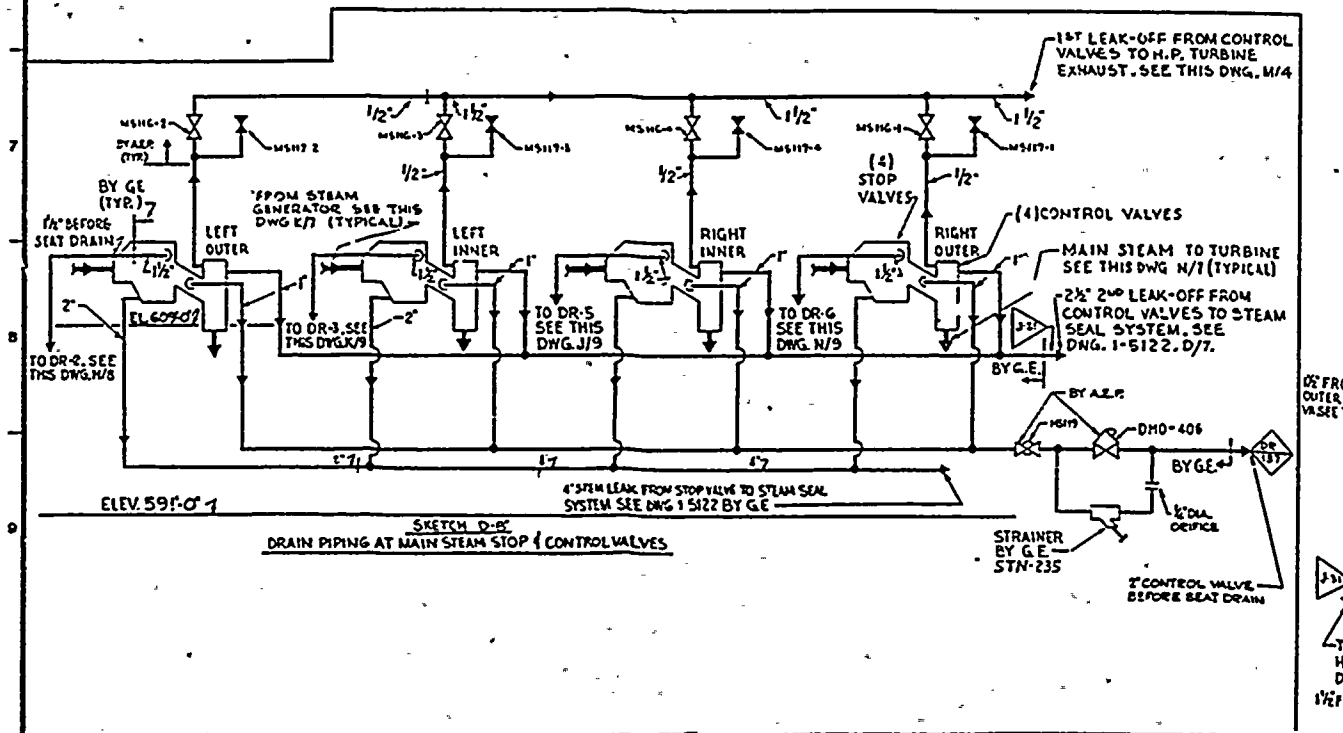
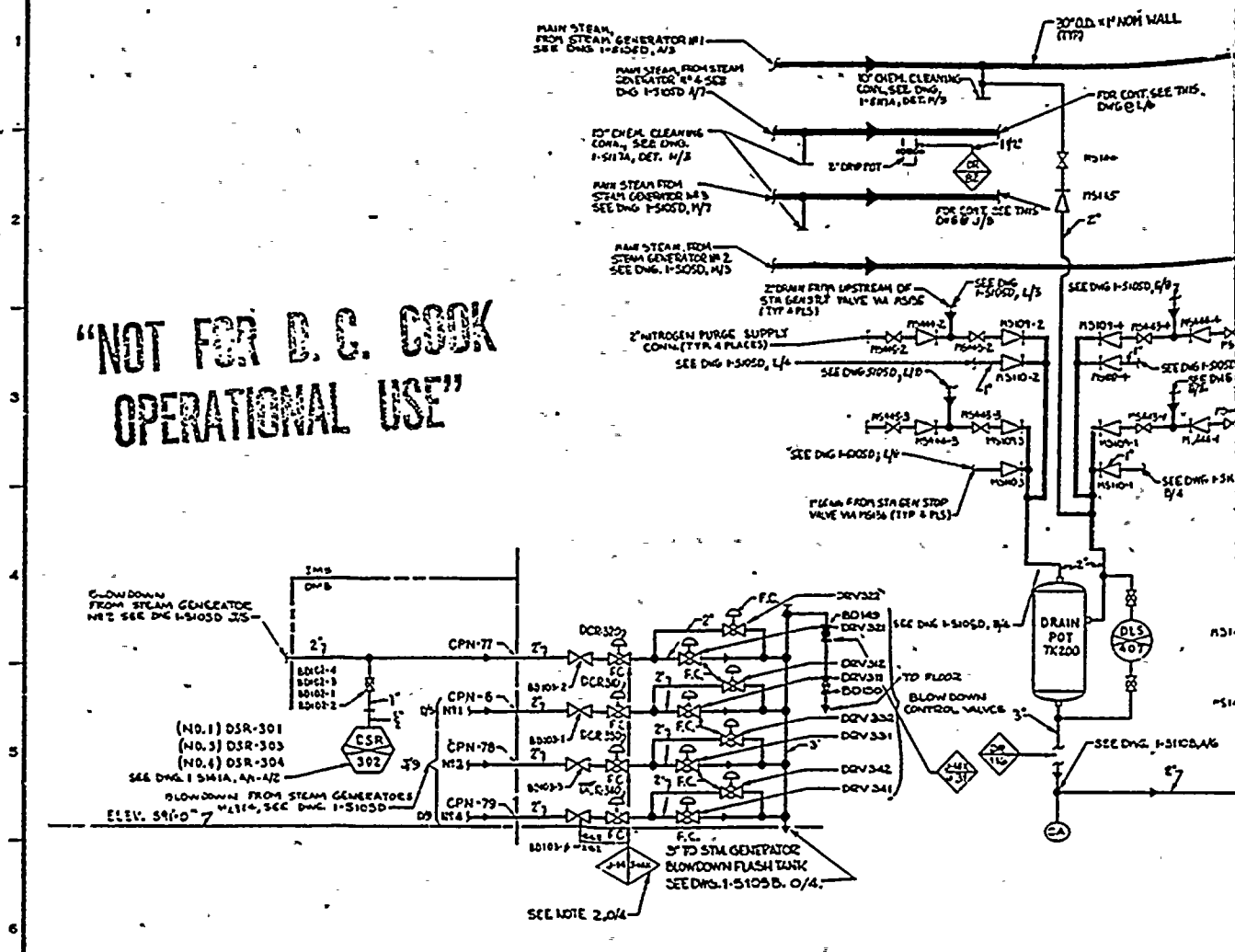

GENERAL NOTES

LEGEND

- MAIN STEAM
- H.P. TURBINE EXHAUST (BY G.E.)
- - - AUXILIARY PIPING

BY WESTINGHOUSE

FOR VALVE, INSTRUMENT SAMPLING, PIPE MATERIAL AND OTHER SYMBOLS NOT DEFINED ON THIS DWG., AND FOR MARK NUMBER CODES, SEE DWG. 12-5103 & 12-5104.

QUANTITIES: FROM G.E.
HEAT BALANCE
371 HB 136
REVISED 3-25-68
BASED ON REACTOR DESIGN STEAM PRESSURE

NOTE 1
CONNECTIONS FOR TRACER DURING TURBINE PERFORMANCE TESTING.

NOTE 2/D/6
PIPING DESIGNATED 3-1/4\"/>

NOTE 3
FOR CLASSE E INSTRUMENTS BEHIND THE 13\"/>

NOTE 4
SEE DWG. 1-5105 FOR CONTINUATION OF DRAINS. SEE DWG. 1-5104C FOR TERMINATION OF DRAINS AT DRIP RECEIVERS. E.C. USE THE UNIT PREFIX DESIGNATION FOR EACH COMPONENT IDENTIFICATION IS 1\"/>

HAND OPERATED VALVE IDENTIFICATION NUMBERS

- ONLY "UNIQUE VALVE NUMBERS" APPEAR ON THIS DRAWING. SEE SEPARATE VALVE IDENTIFICATION LIST FOR EQUIVALENT DESIGN (MCR) NUMBERS.
- "TAG" NUMBERS MODIFIED FOR DRAWING USE AS FOLLOWS:
TAG NO: 2-MSW05-W APPEARS AS: MSW05
- INSTRUMENT ROOT VALVE MARK NTS NOT SHOWN ON DRAWING (SEE VALVE IDENTIFICATION LIST) DERIVED BY ADDING INSTRUMENT NUMBER:
FOR SINGLE IMULSE: V
FOR DOUBLE IMULSE: VSTREAM
FOR DOUBLE IMULSE: VSTREAM VCONSTRUC

DATE	NO.	APPROVED
5-11-67	29	AW

FOR REVISION DESCRIPTION SEE SEPARATE REVISION RECORD FOR THIS DRAWING

INDIANA & MICHIGAN ELECTRIC
DONALD C. COOK
NUCLEAR PLANT

BRIDGMAN

FLOW DIAGRAM
MAIN STEAM
UNIT NO. 1
SHEET 1 OF 3

DR. NO. 1-5105-29

NO.	DATE	BY	CHKD.
1	5-11-67	AW	
2			
3			
4			

SI APERTURE CARD

Also Available On Aperture Card

9003090184-01

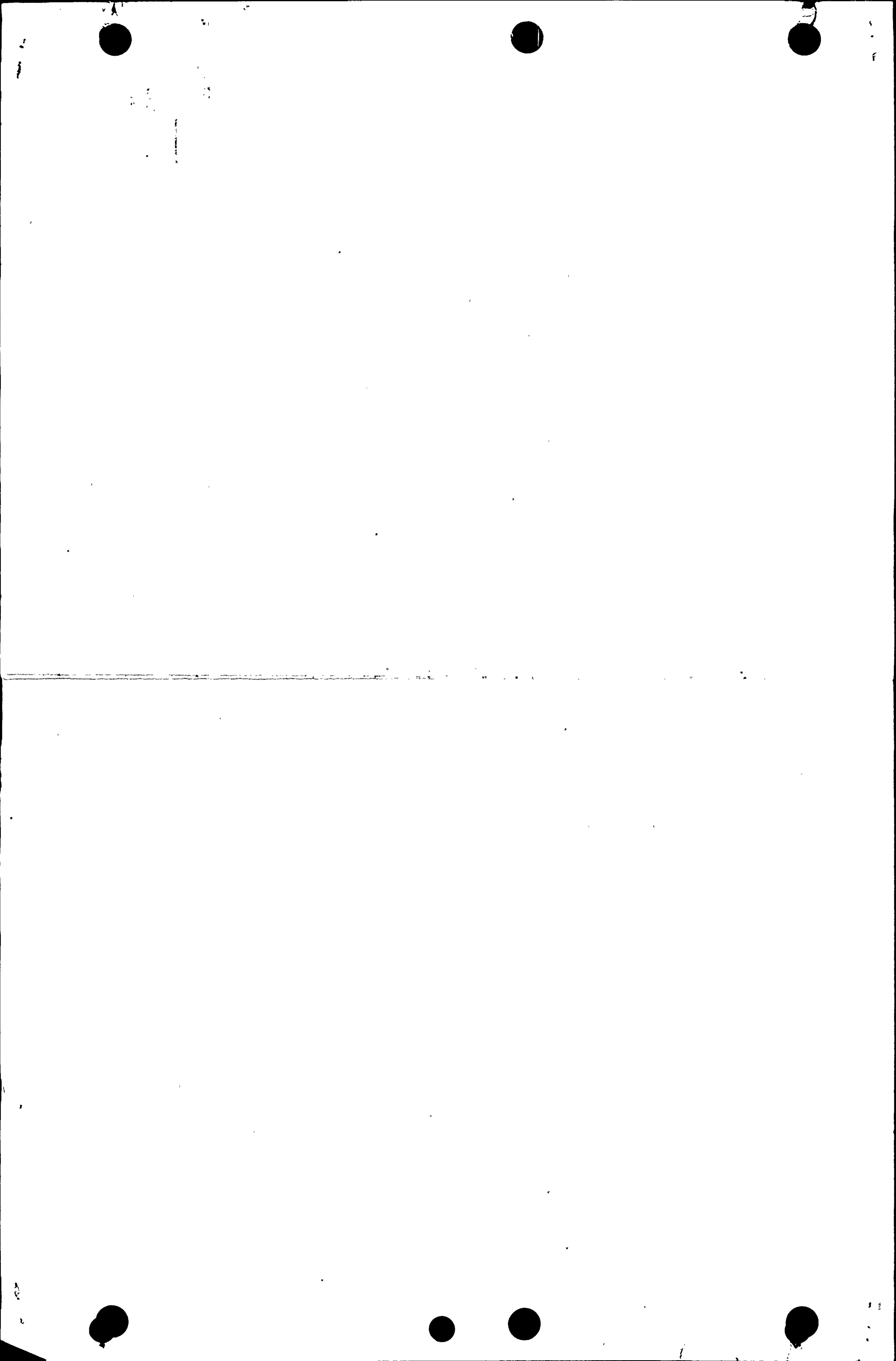

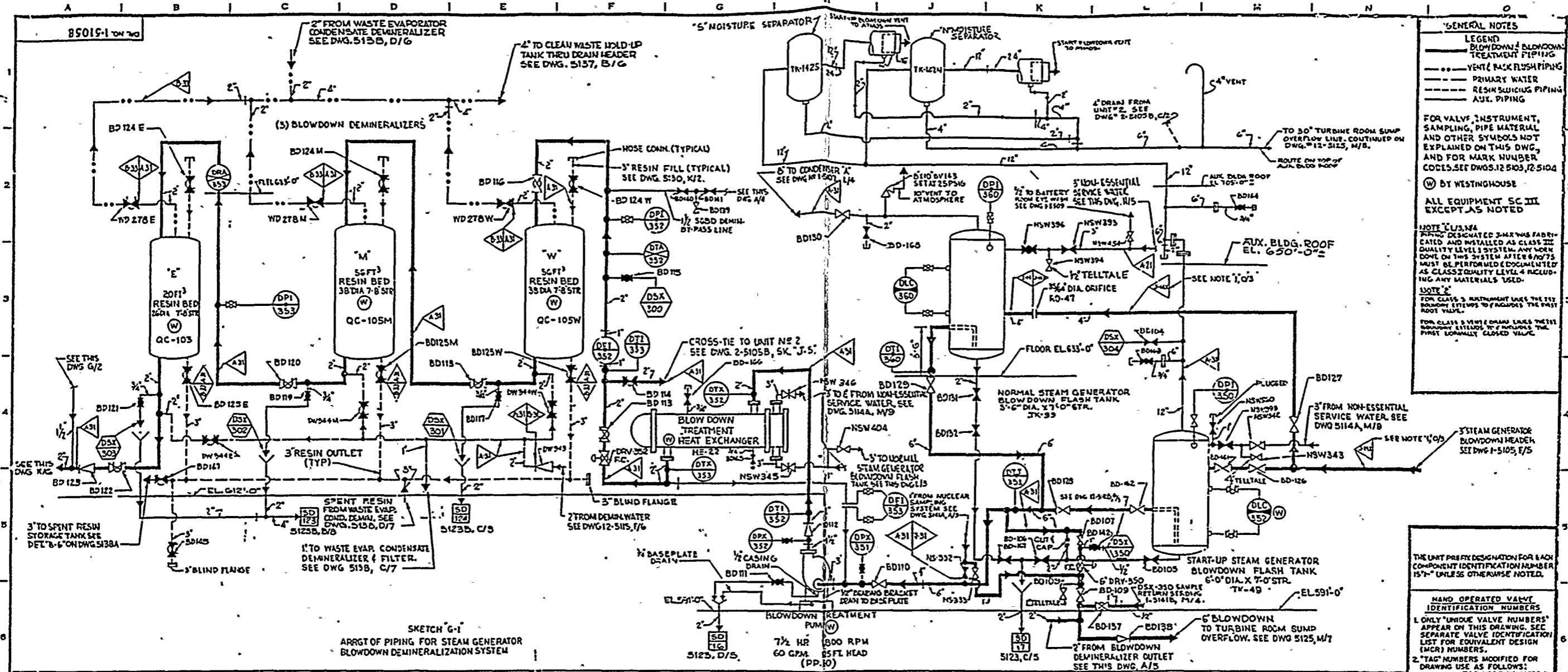

SKETCH G-1
ARRGT OF PIPING FOR STEAM GENERATOR BLOWDOWN DEMINERALIZATION SYSTEM

STEAM FLOW REQUIREMENTS
 6950 LBS/HR PER START-UP EJECTOR
 988 LBS/HR PER STEAM JET AIR EJECTOR
 MAX STEAM PRESSURE=160 PSIG

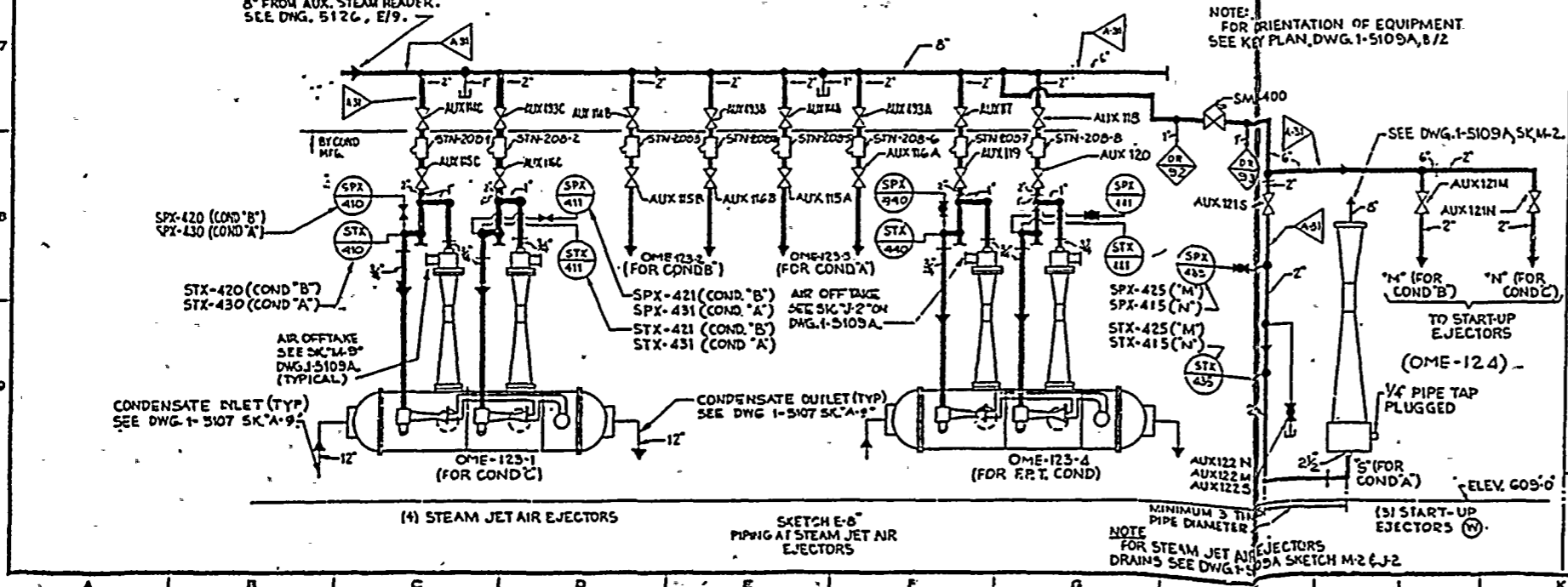

(4) STEAM JET AIR EJECTORS

SKETCH E-8
PIPING AT STEAM JET AIR EJECTORS

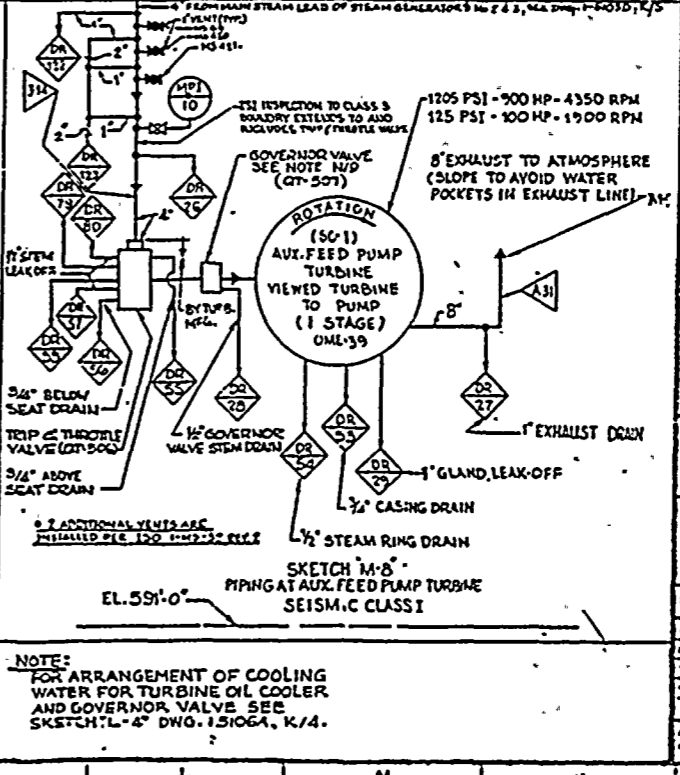

SKETCH M-8
PIPING AT AUX. FEED PUMP TURBINE SEISMIC CLASS I

GENERAL NOTES

LEGEND
 — BLOWDOWN & BLOWDOWN TREATMENT PIPING
 — VENT & BACK FLUSH PIPING
 — PRIMARY WATER
 - - - RESIN BLUICHING PIPING
 — AUX. PIPING

FOR VALVE INSTRUMENT, SAMPLING, PIPE MATERIAL AND OTHER SYMBOLS NOT EXPLAINED ON THIS DWG., AND FOR MARK NUMBER CODES SEE DWGS. 12-5103, 12-5104

BY WESTINGHOUSE

ALL EQUIPMENT SEC. III EXCEPT AS NOTED

NOTE CUS-34
 PIPING DESIGNATED 3-MIX WAS FABRICATED AND INSTALLED AS CLASS III QUALITY LEVEL 3 SYSTEM. ANY WORK DONE ON THIS SYSTEM AFTER 8/6/75 MUST BE PERFORMED DOCUMENTED AS CLASS III QUALITY LEVEL 4 INCLUDING ANY MATERIALS USED.

NOTE CUS-35
 FOR CLASS 3 INSTRUMENT LINES THE 1/2" BLOWDOWN STEMS TO FACED THE FIRST ROOT VALVE.

NOTE CUS-36
 FOR CLASS 3 VENT & DRAIN LINES THE 1/2" BLOWDOWN STEMS TO FACED THE FIRST NORMALLY CLOSED VALVE.

THE UNIT PREFIX DESIGNATION FOR EACH COMPONENT IDENTIFICATION NUMBER IS "U" UNLESS OTHERWISE NOTED.

HAND OPERATED VALVE IDENTIFICATION NUMBERS

1. ONLY "UNIQUE VALVE NUMBERS" APPEAR ON THIS DRAWING. SEE SEPARATE VALVE IDENTIFICATION LIST FOR EQUIVALENT DESIGN (MCR) NUMBERS.

2. TAG NUMBERS MODIFIED FOR DRAWING USE AS FOLLOWS:
 TAG NO: 2-NSW-203-W APPEARS AS: NSW03W

3. INSTRUMENT ROOF VALVE MARK N'S NOT SHOWN ON DRAWING (SEE VALVE IDENTIFICATION LIST) DERIVED BY ADDING TO INSTRUMENT NUMBER:
 FOR SINGLE IMPULSE: V
 FOR DOUBLE IMPULSE: VDC (DOWNSTREAM)

FOR MICROFILM 2 1/2 X 3 1/2" RECORD FILM 11.5" PAGE

DATE: 3-4-87 35
 APPROVED: [Signature]
 FOR REVISION DESCRIPTION SEE SEPARATE REVISION RECORD FOR THIS DRAWING

INDIANA & MICHIGAN ELECTRIC
 DONALD C. COOK
 NUCLEAR PLANT
 BRIDGMAN IN. 2713 E

FLOW DIAGRAM
 MAIN STEAM
 UNIT NO. 1
 SHEET 3 OF 3

DWG. NO. 1-5105B-35

NOT A CONTROLLED COPY

SI APERTURE CARD
 Also Available On Aperture Card

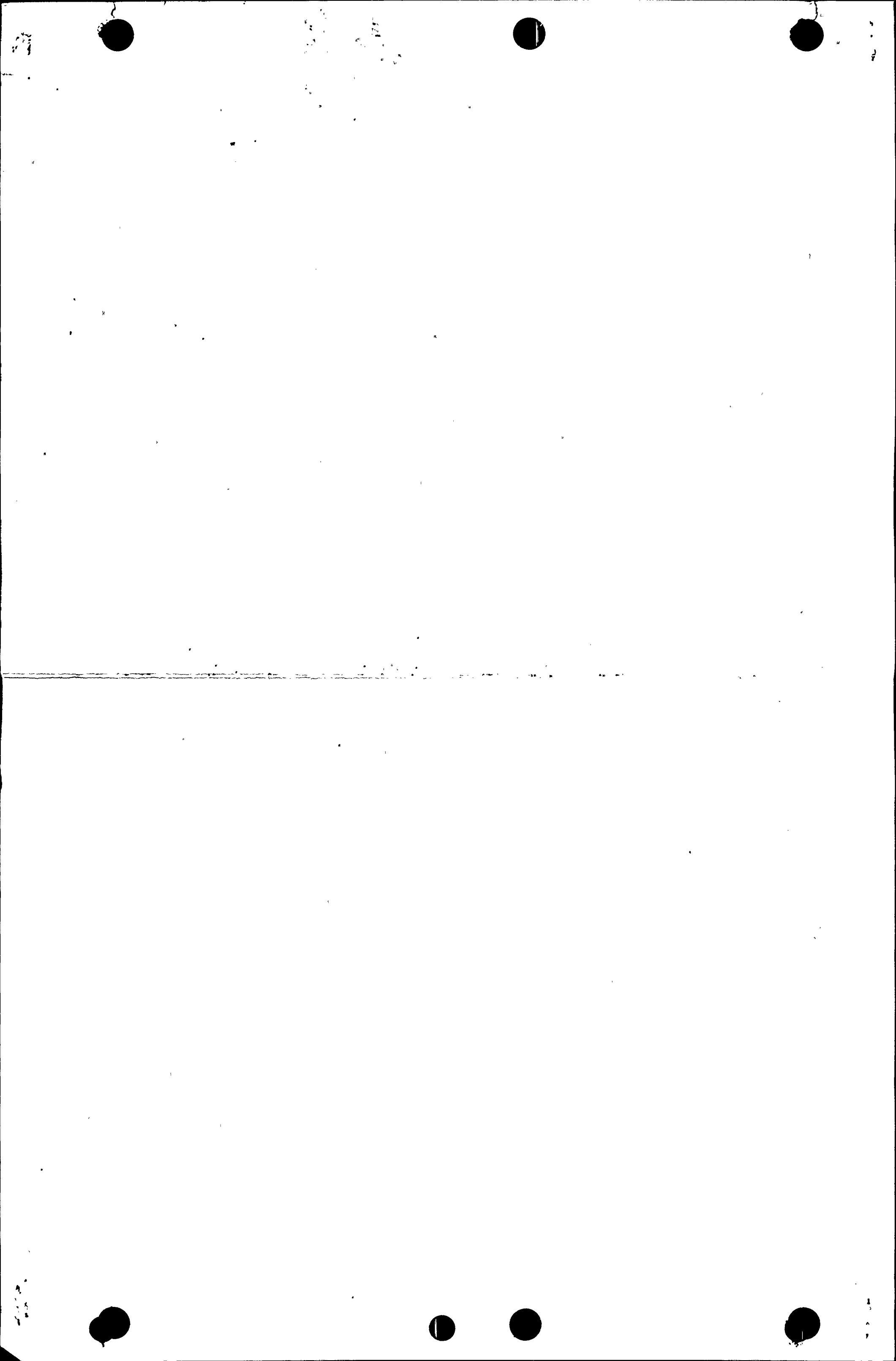

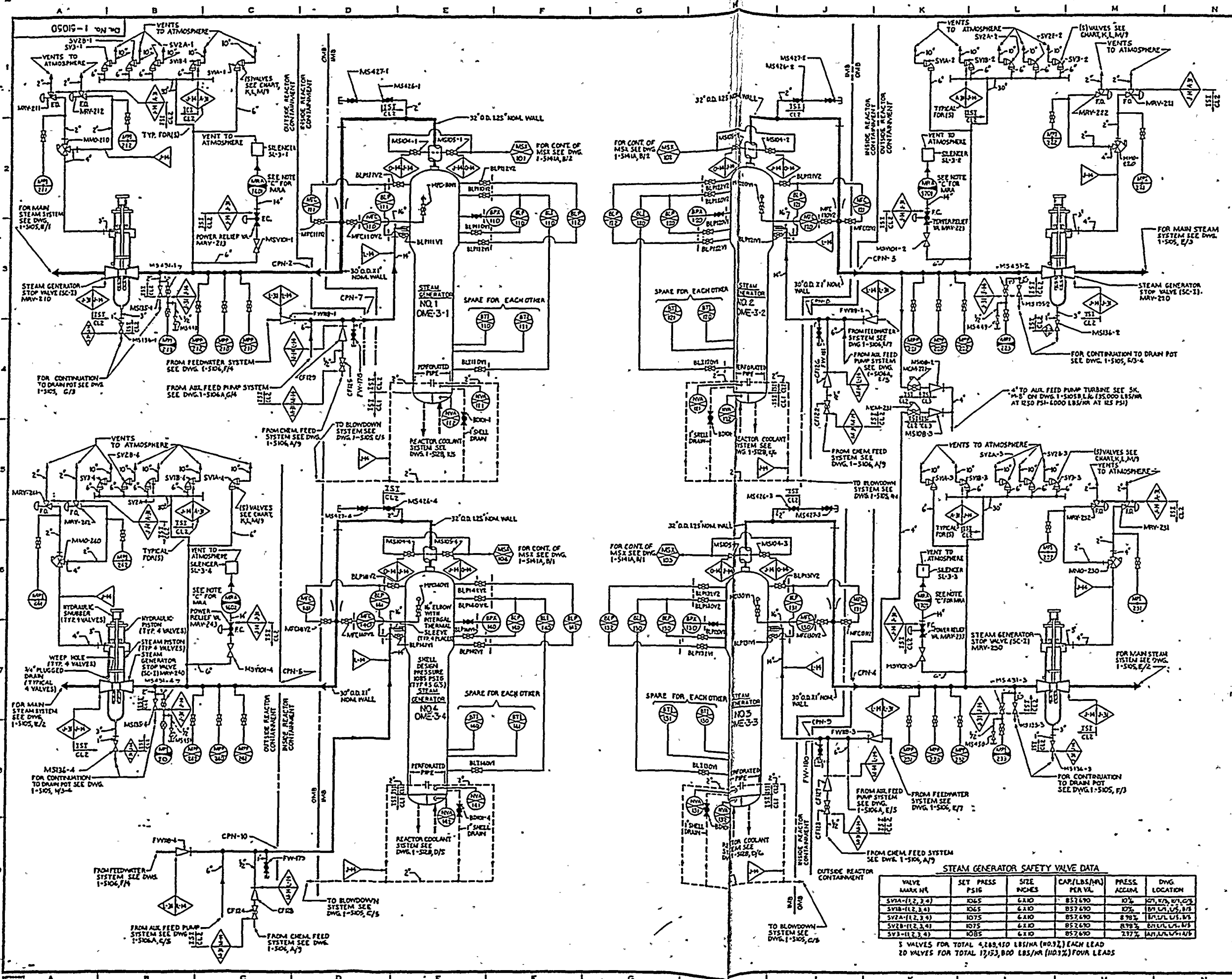

GENERAL NOTES
LEGEND
 ——— MAIN STEAM
 ——— FEEDWATER
 ——— REACTOR COOLANT
 - - - - - AUX. PPNP
 - - - - - BLD/DOWN

FOR VALVE INSTRUMENT SAMPLING PIPE MATERIAL AND OTHER SYMBOLS NOT EXPLAINED ON THIS DWG. AND FOR MARK NUMBER CODES, SEE DWG. 12-5103 & 12-5104.

NOTE 'A'
 ALL EQUIPMENT E.C. 3 EXCEPT AS NOTED.

NOTE 'B'
 FOR CODE CLASS 2 INSTRUMENT SAMPLE CONNECTIONS THE BOUNDARY EXTENDS TO AND INCLUDES THE FIRST ROOT VALVE.

NOTE 'C'
 DETECTOR IS IN PROXIMITY TO PIPE BUT NOT PHYSICALLY ATTACHED FOR DETAIL. SEE DWG. 1-5104F, 5104G-8C.

HAND OPERATED VALVE IDENTIFICATION MATTERS
 1. ONLY SINGLE VALVE MARKERS APPEAR ON THIS DRAWING. SEE SEPARATE VALVE IDENTIFICATION LIST FOR EQUIPMENT DESIGN (LUG) MARKERS.
 2. TAG NUMBERS MODIFIED FOR DRAWING USE AS FOLLOWS:
 TAG NO. 2-MSW-VOS-W APPEARS AS MSWOSW
 3. INSTRUMENT ROOT VALVE MARK NO'S NOT SHOWN ON DRAWING. SEE VALVE IDENTIFICATION LIST DERIVED BY ADDING TO INSTRUMENT NUMBER:
 FOR SINGLE IMPULSIVE: +1V FOR DOUBLE IMPULSIVE: +2V FOR DOUBLE IMPULSIVE WITH STREAM: +2V/DN+STRM

NOTES:
 THE UNIT PREFIX DESIGNATION FOR EACH COMPONENT IDENTIFICATION NO. IS "1" UNLESS OTHERWISE NOTED.

DATE	NO.	APPROVED

FOR REVISION DESCRIPTION SEE SEPARATE REVISION RECORD FOR THIS DRAWING

INDIANA & MICHIGAN ELECTRIC CO.
 DONALD C. COOK
 NUCLEAR PLANT

BRIDGMAN MORGAN
**FLOW DIAGRAM
 STEAM GENERATING
 SYSTEM**
 UNIT NO. 1

DR. NO. 1-5105D-1

AMERICAN ELECTRIC POWER SERVICE CORP.

STEAM GENERATOR SAFETY VALVE DATA

VALVE MARK NO.	SET PRESS. PSIG	SIZE INCHES	CAP. (LBS./HR) PER VAL.	PRESS. ACCUM.	DWG. LOCATION
SV1A-(1,2,3,4)	1065	6.00	857,600	10%	27, 27A, 27B, 27C
SV1B-(1,2,3,4)	1065	6.00	857,600	10%	27A, 27B, 27C, 27D
SV2A-(1,2,3,4)	1075	6.00	857,600	8.75%	27A, 27B, 27C, 27D
SV2B-(1,2,3,4)	1075	6.00	857,600	8.75%	27A, 27B, 27C, 27D
SV3-(1,2,3,4)	1085	6.00	857,600	7.75%	27A, 27B, 27C, 27D

3 VALVES FOR TOTAL 4,285,950 LBS/HR (NO. 3) EACH LEAD
 20 VALVES FOR TOTAL 17,153,800 LBS/HR (NO. 2) FOUR LEADS

SI
 APERTURE
 CARD

Also Available On
 Aperture Card

NOT A GUARANTEED COPY
 FOR INFORMATION ONLY

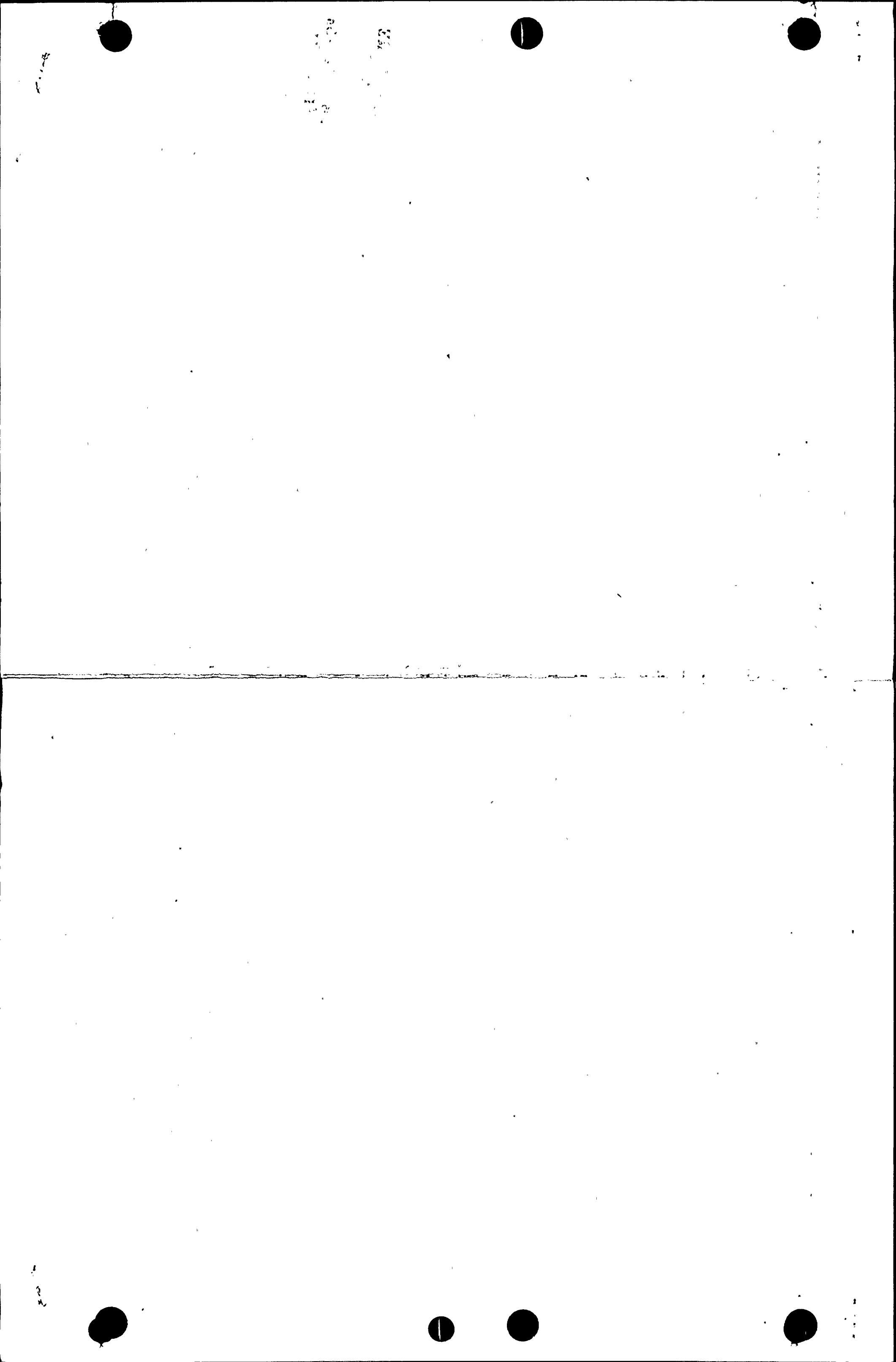

**"NOT FOR D. C. COOK
OPERATIONAL USE"**

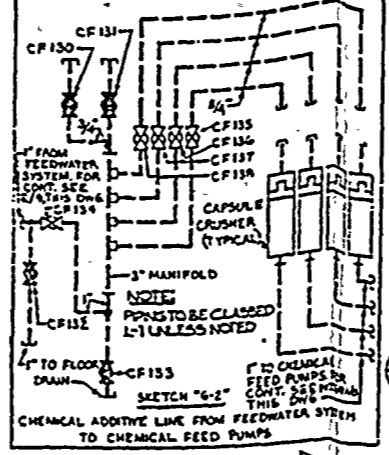

NOTE: FOR CLASS 2 & 3 VENTS AND DRAINING THE 151 BOUNDARY EXTENDS TO AND INCLUDES THE FIRST NORMALLY CLOSED VALVE.

GENERAL NOTES

LEGEND

— FEEDWATER
- - - AUX. PIPING
- - - CHEM. FEED PIPING

FOR VALVE, INSTRUMENT, SAMPLING, PIPE MATERIAL AND OTHER SYMBOLS NOT EXPLAINED ON THIS DWG., AND FOR MARK NUMBER CODES, SEE DWG. B10.4.

NOTE: ALL EQUIPMENT SEISMIC CLASS III EXCEPT AS NOTED

QUANTITIES PER G.E. CO-HEAT BALANCE 3711316 V.M.D. REVISED 3-25-66 & B.B. CO. HEAT BALANCE D10240/0 DATED 12-17-68 AT MAX. REACTOR POWER

NOTE: ALL H/S, O/S CHEMICAL CLEANING CONNECTIONS PROVIDED FOR CONDENSATE FEEDWATER SYSTEM CHEMICAL CLEANING.

SEE DWG. 1-5109B FOR MISC. COND. S. O. HEATERS (E.G., VENTS, DRAINS, ETC.).

SYMBOLS

□ QUICK-DISCONNECT COUPLING

NOTE: FOR CLASS 2 INSTRUMENT CONNECTIONS, THE 151 BOUNDARY EXTENDS TO AND INCLUDES THE FIRST FOOT VALVE. THE PREFIX DESIGNATION FOR EACH COMPONENT IDENTIFICATION NUMBER IS "1" UNLESS OTHERWISE NOTED.

NOTE: THIS DRAWING MADE UNIQUE TO THIS UNIT BY PLACING THE SERIAL NO. IN THE UNIT IDENTIFICATION NUMBER.

HAND OPERATED VALVE IDENTIFICATION NUMBERS

1. ONLY "UNIQUE VALVE NUMBERS" APPEAR ON THIS DRAWING. SEE SEPARATE VALVE IDENTIFICATION LIST FOR EQUIVALENT DESIGN (MCR) NUMBERS.

2. TAG NUMBERS MODIFIED FOR DRAWING USE AS FOLLOWS: TAG NO. 2-NH-1000-W APPEARS AS: 1000W

3. INSTRUMENT ROOT VALVE MARK N'S NOT SHOWN ON DRAWING. SEE VALVE IDENTIFICATION LIST DERIVED BY ADDING TO INSTRUMENT NUMBER: FOR SINGLE IMPULSE: V FOR DOUBLE IMPULSE: V2

DATE: 1-15-65

FOR REVISION DESCRIPTION SEE SEPARATE REVISION RECORD FOR THIS DRAWING

THIS DRAWING IS THE PROPERTY OF THE AMERICAN ELECTRIC POWER SERVICE CORP. AND IS LOANED TO YOU BY THE AMERICAN ELECTRIC POWER SERVICE CORP. IT IS TO BE USED ONLY FOR THE PROJECT AND SITE FOR WHICH IT IS ISSUED. IT IS NOT TO BE REPRODUCED OR TRANSMITTED IN ANY FORM OR BY ANY MEANS, ELECTRONIC OR MECHANICAL, INCLUDING PHOTOCOPYING, RECORDING, OR BY ANY INFORMATION STORAGE AND RETRIEVAL SYSTEM, WITHOUT THE WRITTEN PERMISSION OF THE AMERICAN ELECTRIC POWER SERVICE CORP.

INDIANA & MICHIGAN ELECTRIC CO.
DONALD C. COOK
NUCLEAR PLANT

FLOW DIAGRAM - FEEDWATER

UNIT NO. 3 SHEET 1 OF 3

DWG. NO. 1-5107-25

AMERICAN ELECTRIC POWER SERVICE CORP.
2 BROADWAY
NEW YORK

SI APERTURE CARD

Also Available On Aperture Card

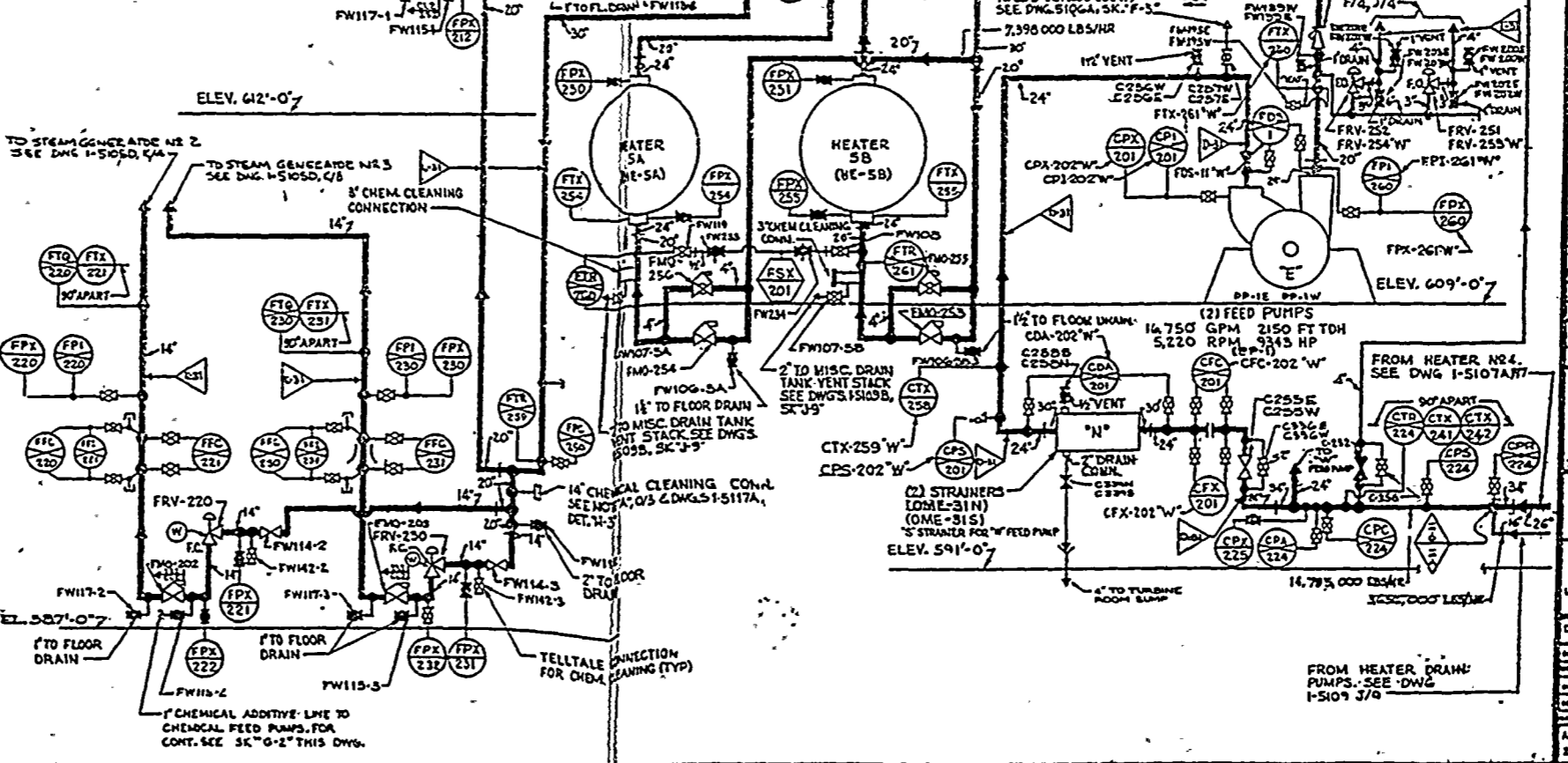
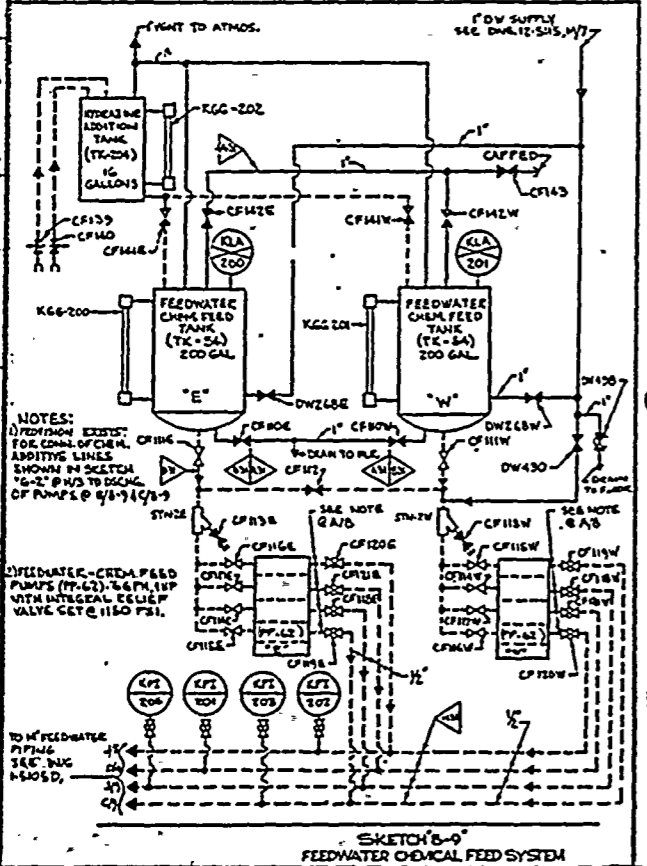

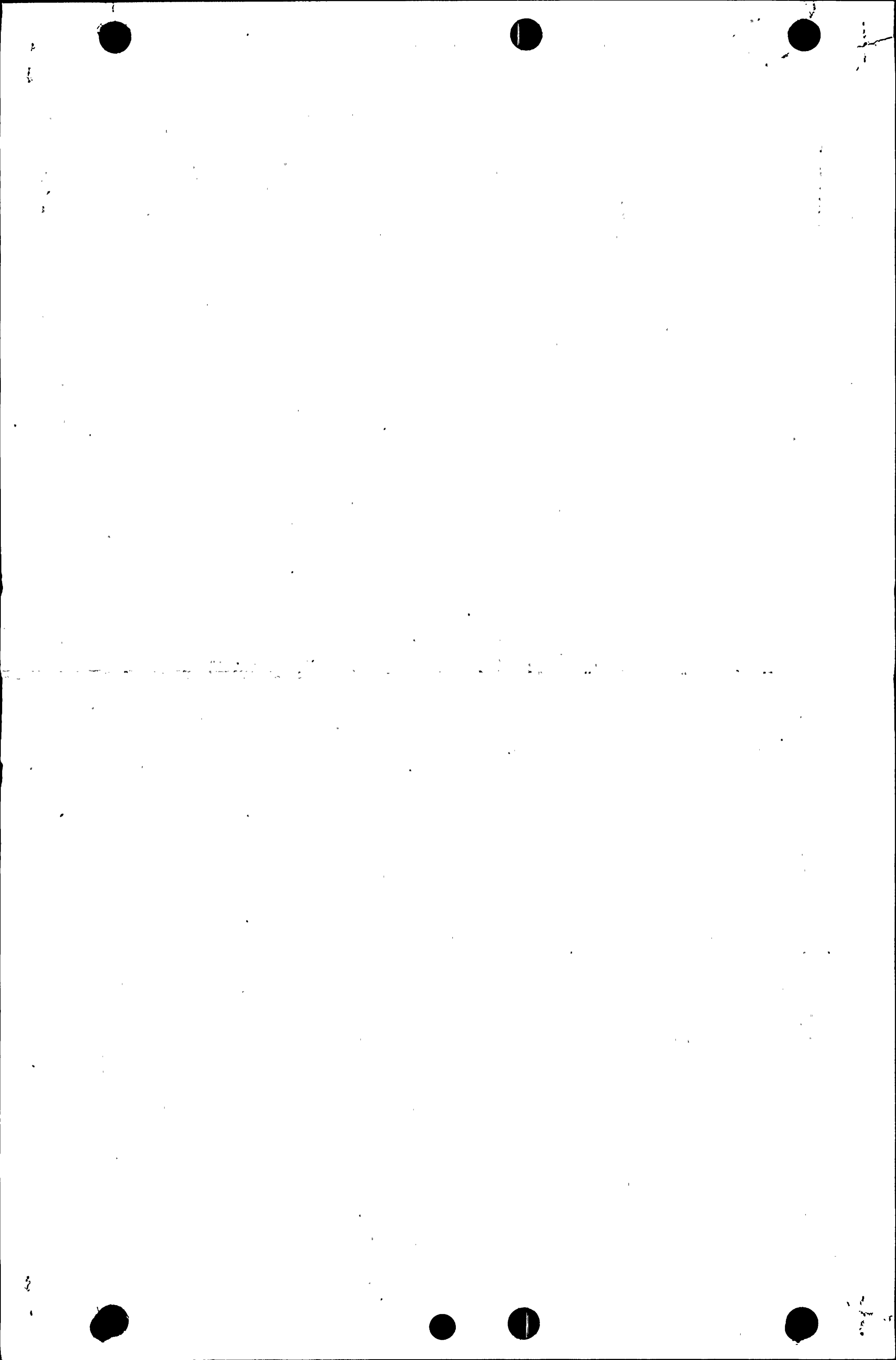

**"NOT FOR D. C. COOK
OPERATIONAL USE"**

DR. NO. 1-5106A

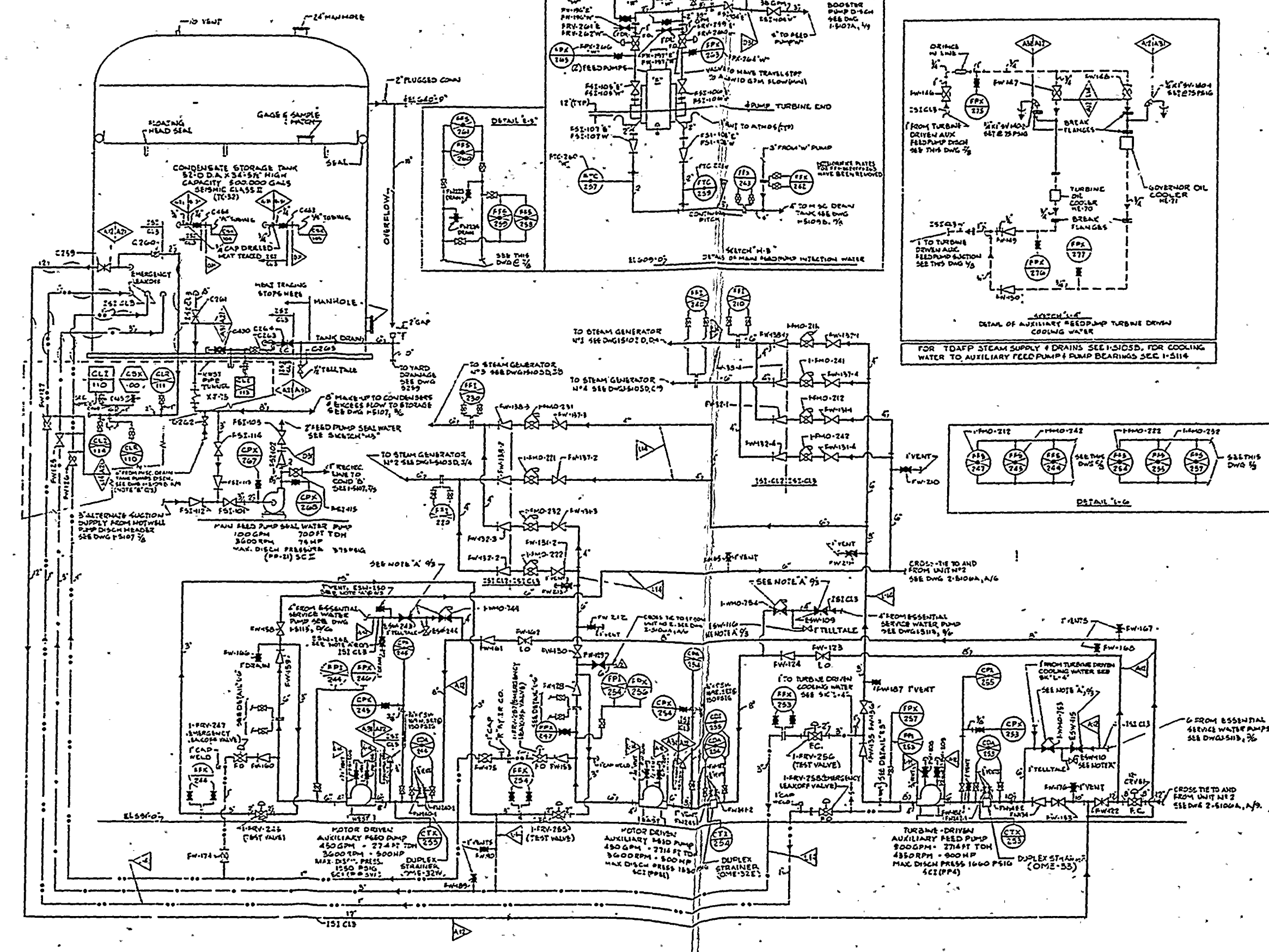

GENERAL NOTES

- AUX FEEDWATER
 - AUX. PIPING
 - COOLING WATER
 - TEST LINE
 - EMERGENCY LEAKOFF
- (V) BY WESTINGHOUSE
FOR VALVE INSTRUMENT, SAMPLING PIPE MATERIAL AND OTHER SYMBOLS NOT EXPLAINED ON THIS DWG. AND FOR MORE VALVE CODES SEE DWG 12-5103 & 12-5104.
THE UNIT PREFIX DESIGNATION FOR EACH COMPONENT IDENTIFICATION NUMBER IS "1" UNLESS OTHERWISE NOTED.
- NOTE 'A'
VALVES ALSO SHOWN (AND NUMBERS) ON DWG 5115. NOT TO BE DUPLICATED.
- NOTE 'B'
FROM MISC DRAIN DUNK, USED FOR HEATING SYSTEM OPERATION DURING CONSTRUCTION AND ON OCCASIONS WHEN BOTH UNITS ARE IN OPERATION.
- THIS DWG. MADE UNIQUE FOR UNIT 1 FROM DWG. 12-5106A REV.25
- NOTE 'C'
EQUIPMENT SEISMIC CLASSIFICATION AS NOTED.
- NOTE 'D'
INSTRUMENT AND ISOLATION VALVE IN TURBINE DEVENAUX FEED PUMP ROOM.
- NOTE:
1. FOR CODE CLASS 2 & 3 INSTRUMENT CONNECTIONS, THE ISOLATION BOUNDARY EXTENDS TO AND INCLUDES THE FIRST ROOT VALVE.
2. FOR CODE CLASS 2 & 3 VENTS & DRAINS, THE ISOLATION BOUNDARY EXTENDS TO AND INCLUDES THE FIRST ISOLATION VALVE.
- HAND OPERATED VALVE IDENTIFICATION NUMBERS
1. ONLY UNIQUE VALVE NUMBERS APPEAR ON THIS DRAWING. SEE SEPARATE VALVE IDENTIFICATION LIST FOR EQUIVALENT DESIGN (MCR) NUMBERS.
 2. TAG NUMBERS MODIFIED FOR DRAWING USE AS SHOWN IN TAG #1 IDENTIFICATION APPEAR AS 12NSW05W.
 3. INSTRUMENT ROOT VALVE MARK 'S' NOT SHOWN ON DRAWING. (SEE VALVE IDENTIFICATION LIST) DERIVED BY ADDING TO INSTRUMENT NUMBER: 'S' FOR DOUBLE MAINTENANCE FOR DOUBLE MAINTENANCE (M/M).
- DATE: 4-15-57
NO. 38
APPROVED: [Signature]
- FOR REVISION DESCRIPTION SEE SEPARATE REVISION RECORD FOR THIS DRAWING.
- INDIANA & MICHIGAN ELECTRIC CO.
DONALD C. COOK
NUCLEAR PLANT
BRIDGMAN MICHIGAN
- FLOW DIAGRAM
AUX. FEED WATER**
- UNIT 1
DR. NO. 1-5106A - 38
- | | | | |
|----------|---------|-------------|-------------|
| SCALE | DATE | BY | CHKD. |
| AS SHOWN | 4-15-57 | [Signature] | [Signature] |
| DESIGNED | | [Signature] | [Signature] |
| CHECKED | | [Signature] | [Signature] |
| APPROVED | | [Signature] | [Signature] |
| DATE | | | |
- AMERICAN ELECTRIC POWER SERVICE CORP.

**SI
APERTURE
CARD**

Also Available On
Aperture Card

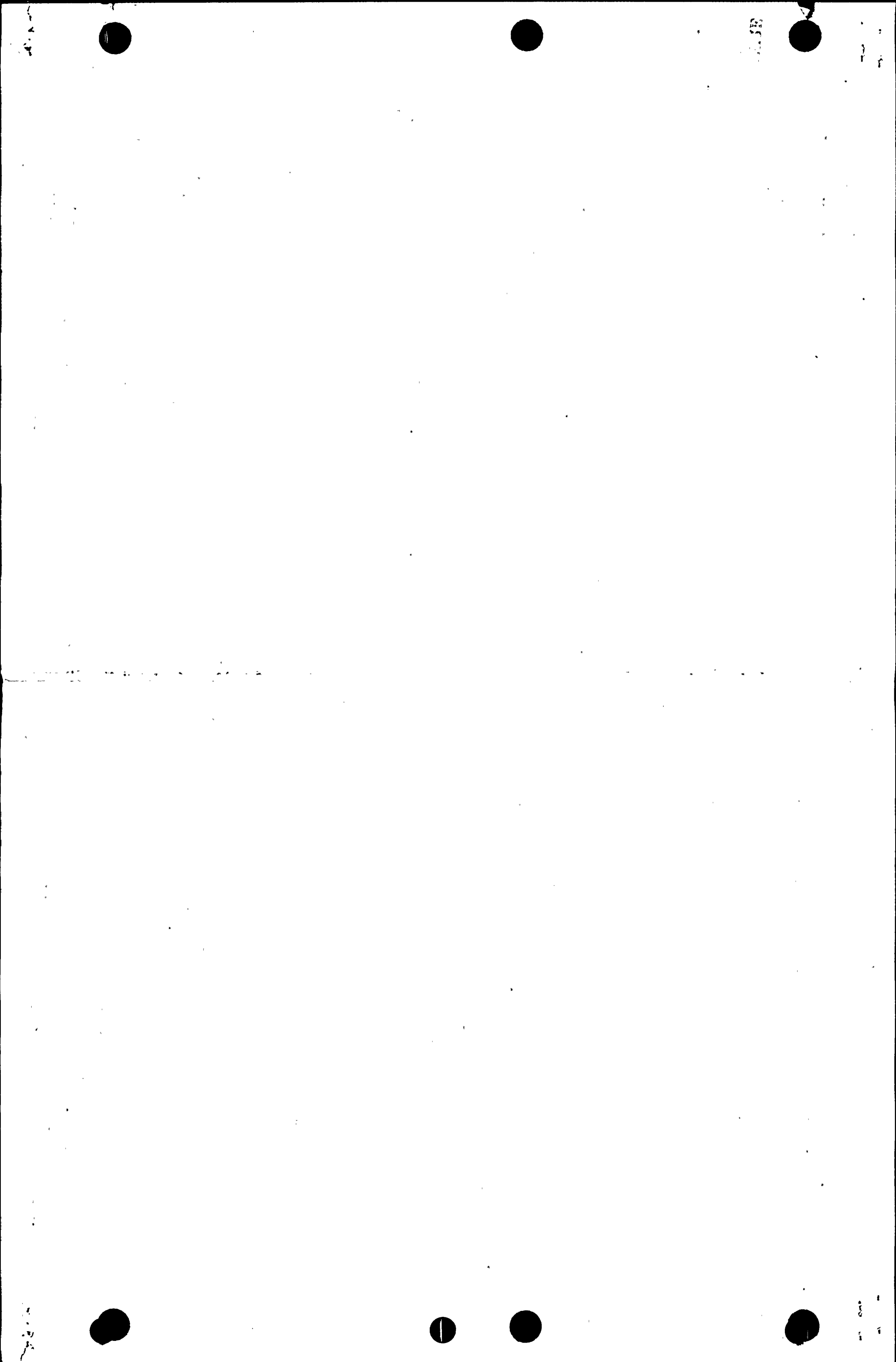

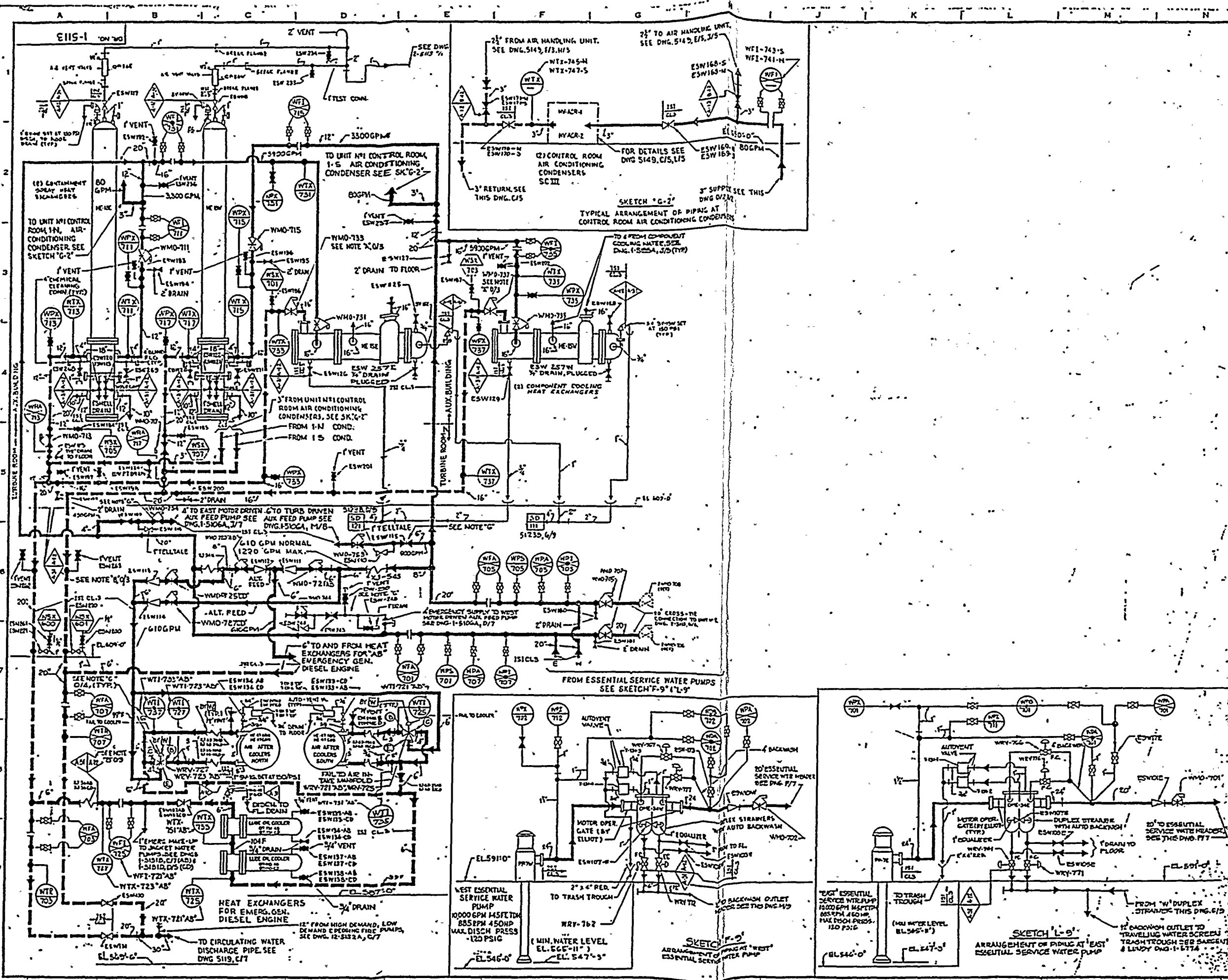

GENERAL NOTES.

- LEGEND**
- SUPPLY PIPING
 - RETURN PIPING
 - AUX. PIPING

ALL PIPING CLASS A-12 UNLESS NOTED
 ALL EQUIPMENT SEISMIC CLASS I, EXCEPT AS-NOTED.
 FOR VALVE, INSTRUMENT, SAMPLING, PIPE MATERIAL AND OTHER SYMBOLS NOT EXPLAINED ON THIS DWG., AND FOR MARK NUMBER CODES, SEE DWG. 5104

SYMBOL
 W BY WORTHINGTON

NOTE 'A': C/3, E/3
 WMO-733, 737 TO HAVE INTERMEDIATE LIMIT SWITCH TO LIMIT FLOW ON SAFETY INJECTION SIGNAL

NOTE 'B': B/5
 RETURN PIPING CHANGES FROM CLASS I (AUX. BLDG) TO CLASS III (TURBINE ROOM)

NOTE 'C': B/7, E/7
 ENCLOSED LETTERS ARE SHOWN FOR ORIENTATION OF VALVE IN PIPING. THESE LETTERS REFLECT SIMILAR MARKINGS ON VALVE BODY

NOTE 'D': THIS DWG. MADE UNIFORM AND SUPPLEMENTED DWG. 12-5110-21

NOTE 'E': FOR CODE CLASS B/8/10/2, THE 1/2" BOUNDARY EXTENDS TO AND INCLUDES THE FIRST NORMALLY CLOSED VALVE.

NOTE 'F': FOR CODE CLASS B/8/10/2, THE 1/2" BOUNDARY EXTENDS TO AND INCLUDES THE FIRST NORMALLY CLOSED VALVE.

NOTE 'G': VALVES ALSO SHOWN (AND NUMBERED) ON DWG. 1-5106A.

NOTE 'H': THE UNIT PREFIX DESIGNATION FOR EACH COMPONENT IDENTIFICATION NUMBER IS 'W' UNLESS OTHERWISE NOTED.

HAND OPERATED VALVE IDENTIFICATION NUMBERS
 1. ONLY 'UNIQUE' VALVE NUMBERS APPEAR ON THIS DRAWING. SEE SEPARATE VALVE IDENTIFICATION LIST FOR EQUIVALENT DESIGN - (MCR) NUMBERS.
 2. TAG NUMBERS MODIFIED FOR DRAWING USE AS FOLLOWS:
 TAG #1: 2-NSW-VIOS-W APPEARS AS: NSWVOSW
 3. INSTRUMENT ROOT VALVE MARK #1'S NOT SHOWN ON DRAWING (SEE VALVE IDENTIFICATION LIST) DERIVED BY ADDING TO INSTRUMENT NUMBER:
 FOR SINGLE IMPL. (CV) FOR DOUBLE IMPL. (VLP/STREAM) V2CONSTRUC

L-1-87 21 REV 1/87
 DATE NO APPROVED
 FOR REVISION DESCRIPTION SEE SEPARATE REVISION RECORD FOR THIS DRAWING

THIS DRAWING IS THE PROPERTY OF THE AMERICAN ELECTRIC POWER SERVICE CORP. AND IS LOANED TO YOU FOR YOUR INFORMATION ONLY. IT IS NOT TO BE REPRODUCED OR COPIED IN ANY MANNER WITHOUT THE WRITTEN CONSENT OF THE AMERICAN ELECTRIC POWER SERVICE CORP. AND IS TO BE RETURNED UPON REQUEST.

INDIANA & MICHIGAN ELECTRIC CO.
 DONALD C. COOK
 NUCLEAR PLANT
 BRIDGEVILLE MICHIGAN

FLOW DIAGRAM ESSENTIAL SERVICE WATER UNITS NO. 1

DWG. NO. 1-5113-41
 AMERICAN ELECTRIC POWER SERVICE CORP.
 2 BROADWAY NEW YORK

SI APERTURE CARD

Also Available On Aperture Card

NOT A CONTROLLED COPY

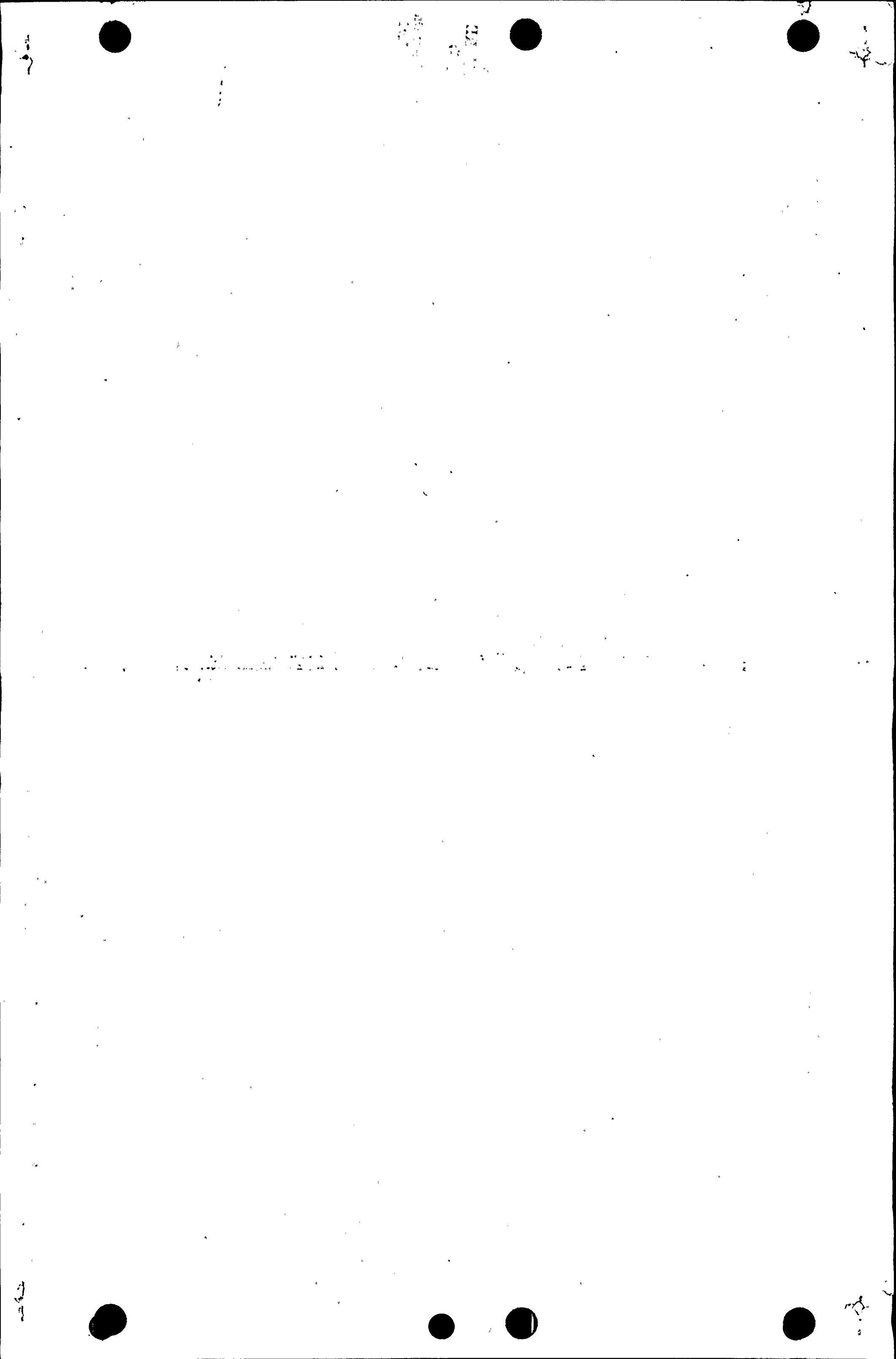

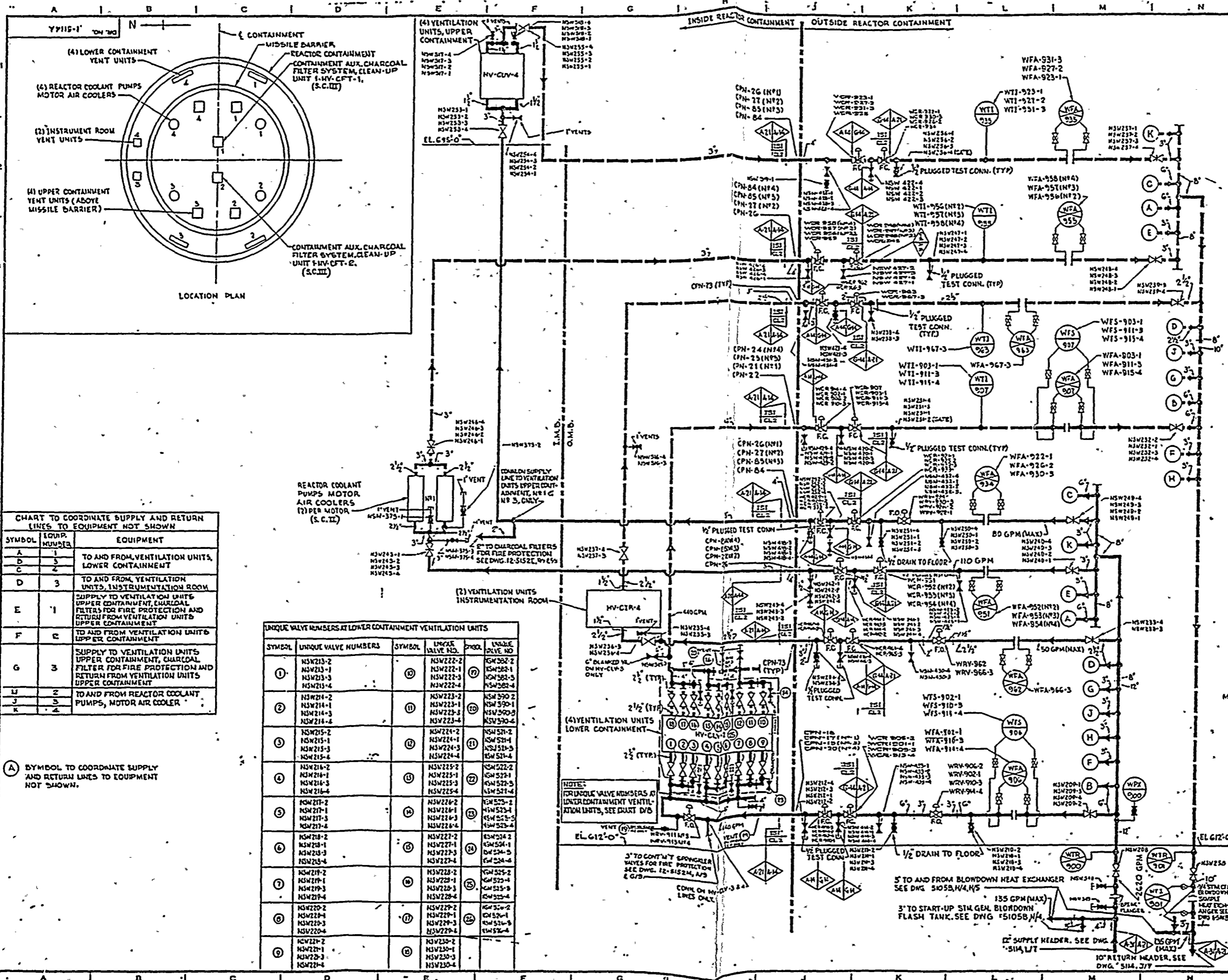

GENERAL NOTES

LEGEND
 — SUPPLY PIPING
 — RETURN PIPING
 - - - AUXILIARY PIPING

FOR VALVE, INSTRUMENT, SAMPLING, PIPE MATERIAL AND OTHER SYMBOLS NOT EXPLAINED ON THIS DWG., AND FOR MARK NUMBER CODES, SEE DWG. 5104.

NOTES:
 A. ALL EQUIPMENT SEISMIC CLASS 2 EXCEPT AS NOTED.
 B. FOR CODE CLASS 2 MUST COMPLY THE 151 BOUNDARY EXTENDS TO & INCLUDES THE FIRST ROOT VALVE.
 C. FOR CODE CLASS 2 VENTS & DRAINS, THE 151 BOUNDARY EXTENDS TO INCLUDES THE FIRST NORMALLY CLOSED VALVE.

THE UNIT PREFIX DESIGNATION FOR EACH COMPONENT IDENTIFICATION NUMBER IS "1" UNLESS OTHERWISE NOTED.

HAND OPERATED VALVE IDENTIFICATION NUMBERS
 1. ONLY "UNIQUE VALVE NUMBERS" APPEAR ON THIS DRAWING. SEE SEPARATE VALVE IDENTIFICATION LIST FOR EQUIVALENT DESIGN (MCR) NUMBERS.
 2. "TAG" NUMBERS MODIFIED FOR DRAWING USE AS FOLLOWS:
 TAG NO. 2-NW2105-W APPEARS AS: 2NW105
 3. INSTRUMENT ROOT VALVE MARK "R" IS NOT SHOWN ON DRAWING (SEE VALVE IDENTIFICATION LIST). DERIVED BY ADDING TO INSTRUMENT NUMBER FOR SINGLE IMPULSE (V) FOR DOUBLE IMPULSE (VP/STREAM) V2/DW/STRM.

IF 151 BOUNDARY STATUS SEE DWG. 5104 FOR THIS DWG.

DATE: 9-24-61
 NO. 31
 APPROVED: [Signature]

FOR REVISION DESCRIPTION SEE SEPARATE REVISION RECORD FOR THIS DRAWING.

INDIANA & MICHIGAN ELECTRIC CO.
 DONALD C. COOK
 NUCLEAR PLANT

FLOW DIAGRAM NON-ESSENTIAL SERVICE WATER UNIT NO. 1

DWG. NO. 1-5114 A-31

AMERICAN ELECTRIC POWER SERVICE CORP. BROADWAY NEW YORK

CHART TO COORDINATE SUPPLY AND RETURN LINES TO EQUIPMENT NOT SHOWN

SYMBOL	EQUIP. NUMBER	EQUIPMENT
A	1	TO AND FROM VENTILATION UNITS, LOWER CONTAINMENT
D	3	TO AND FROM VENTILATION UNITS, INSTRUMENTATION ROOM
E	1	SUPPLY TO VENTILATION UNITS UPPER CONTAINMENT, CHARCOAL FILTERS FOR FIRE PROTECTION AND RETURN FROM VENTILATION UNITS UPPER CONTAINMENT
F	2	TO AND FROM VENTILATION UNITS UPPER CONTAINMENT
G	3	SUPPLY TO VENTILATION UNITS UPPER CONTAINMENT, CHARCOAL FILTER FOR FIRE PROTECTION AND RETURN FROM VENTILATION UNITS UPPER CONTAINMENT
J	2	TO AND FROM REACTOR COOLANT PUMPS, MOTOR AIR COOLER

UNIQUE VALVE NUMBERS AT LOWER CONTAINMENT VENTILATION UNITS

SYMBOL	UNIQUE VALVE NUMBERS	SYMBOL	UNIQUE VALVE NO.	SYMBOL	UNIQUE VALVE NO.
①	NW213-1 NW213-2 NW213-3 NW213-4	②	NW222-1 NW222-2 NW222-3 NW222-4	③	NW223-1 NW223-2 NW223-3 NW223-4
④	NW214-1 NW214-2 NW214-3 NW214-4	⑤	NW224-1 NW224-2 NW224-3 NW224-4	⑥	NW225-1 NW225-2 NW225-3 NW225-4
⑦	NW215-1 NW215-2 NW215-3 NW215-4	⑧	NW226-1 NW226-2 NW226-3 NW226-4	⑨	NW227-1 NW227-2 NW227-3 NW227-4
⑩	NW216-1 NW216-2 NW216-3 NW216-4	⑪	NW228-1 NW228-2 NW228-3 NW228-4	⑫	NW229-1 NW229-2 NW229-3 NW229-4
⑬	NW217-1 NW217-2 NW217-3 NW217-4	⑭	NW230-1 NW230-2 NW230-3 NW230-4	⑮	NW231-1 NW231-2 NW231-3 NW231-4
⑯	NW218-1 NW218-2 NW218-3 NW218-4	⑰	NW232-1 NW232-2 NW232-3 NW232-4	⑱	NW233-1 NW233-2 NW233-3 NW233-4
⑲	NW219-1 NW219-2 NW219-3 NW219-4	⑳	NW234-1 NW234-2 NW234-3 NW234-4		

(A) SYMBOL TO COORDINATE SUPPLY AND RETURN LINES TO EQUIPMENT NOT SHOWN.

SI APERTURE CARD

Also Available On Aperture Card

NOT A CONTROLLED COPY

9003090184-07

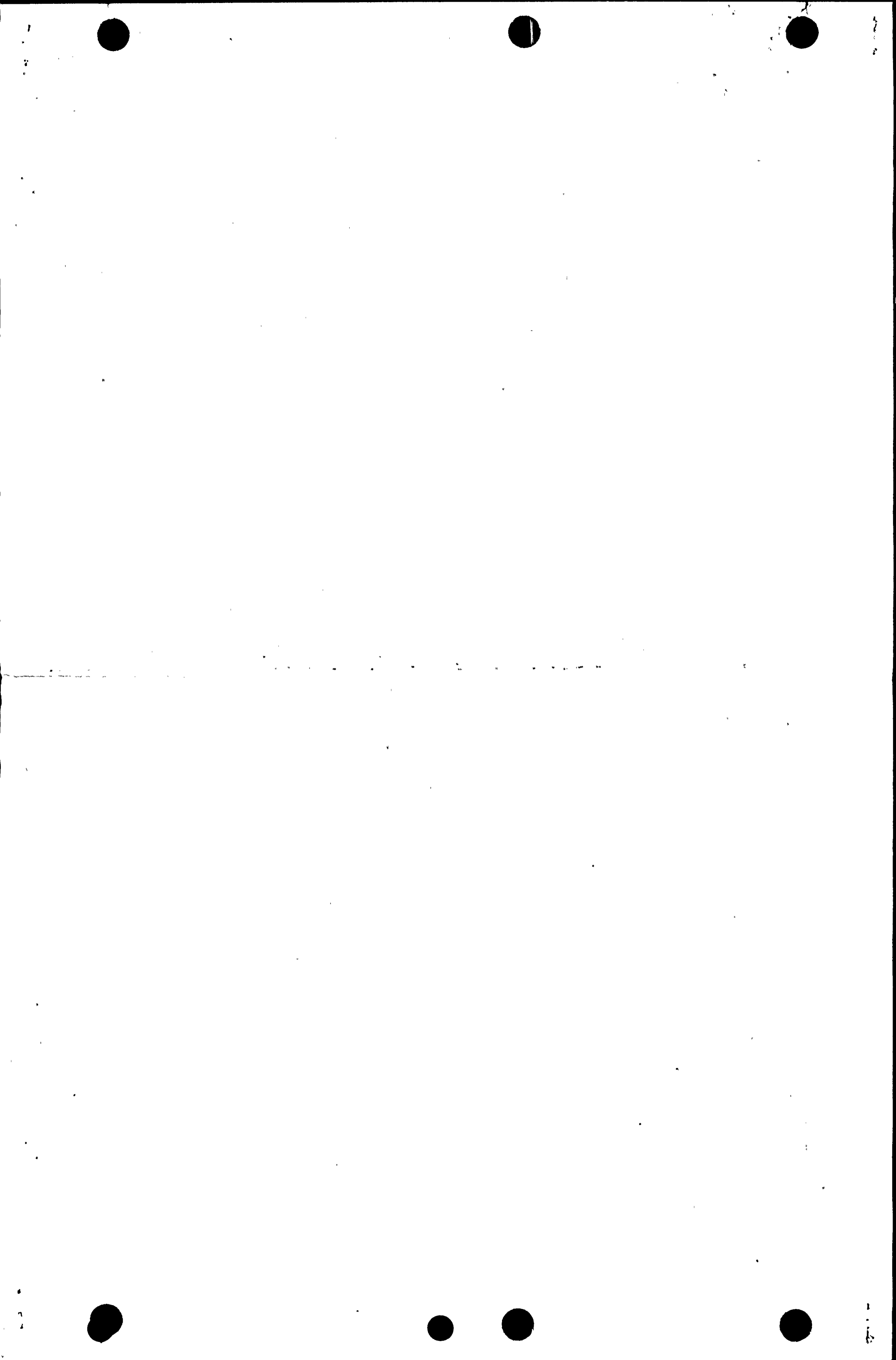

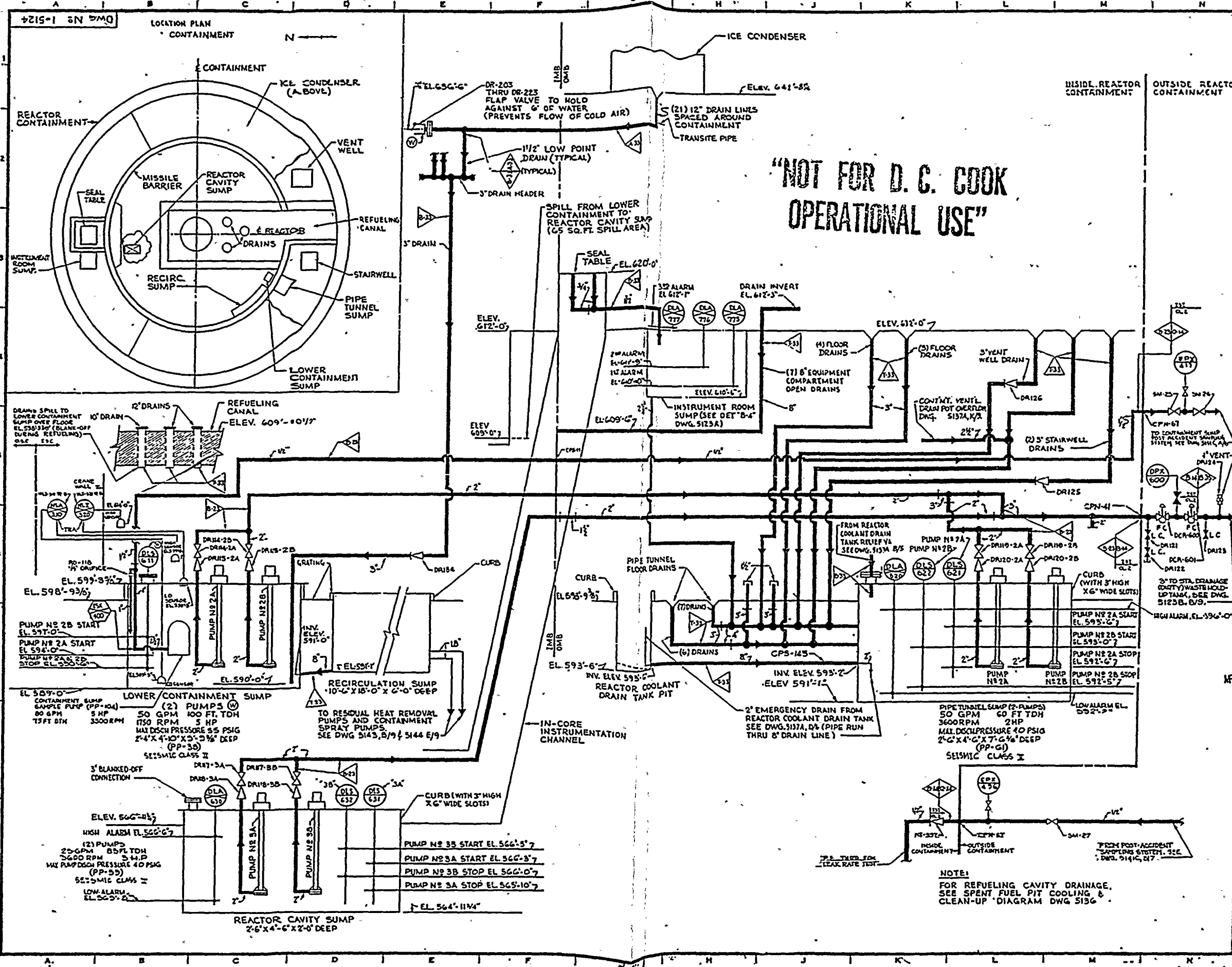

**"NOT FOR D. C. COOK
OPERATIONAL USE"**

**GENERAL NOTES
LEGEND**

- DRAINAGE PIPING
- AUXILIARY PIPING

FOR VALVE, INSTRUMENT, SAMPLING, PIPE MATERIAL AND OTHER SYMBOLS NOT EXPLAINED ON THIS DWG. AND FOR MARK NUMBER CODES, SEE DWG. 5104.

(W) BY WESTINGHOUSE CO.
ALL EQUIPMENT SEISMIC CLASS I EXCEPT AS NOTED

NOTE
1. ALL CONTAINMENT SUMP PUMPS TO BE TRIPPED OFF ON ISOLATE SIGNAL.
2. VALVES SM-25, SM-26, SM-27 ARE TEMPORARY. TO BE PERMANENTLY REPLACED BY ECR-416, 417, 496, 497

SUMPS SEISMIC CLASSIFICATION SAME AS STRUCTURE IN WHICH ARE LOCATED.
FOR CODE CLASS 2 INSTRUMENT CONTROL, THE 1ST ROADSIDE EXTENDS TO AND INCLUDES THE FIRST ROOT VALVE.
FOR CODE CLASS 2 VALVES, THE 1ST ROADSIDE EXTENDS TO AND INCLUDES THE FIRST NORMALLY CLOSED VALVE.

THE UNIT PREFIX DESIGNATION FOR EACH COMPONENT ID NUMBER IS "1-" UNLESS OTHERWISE NOTED.

REV. 11 NOTE!
THIS DWG. MADE UNIQUE FOR UNIT #1 FROM DWG. 1-2-5124 REV. 10

HAND OPERATED VALVE IDENTIFICATION NUMBERS
1. ONLY UNIQUE VALVE NUMBERS APPEAR ON THIS DRAWING. SEE SEPARATE VALVE IDENTIFICATION LIST FOR EQUIVALENT DESIGN (LCA) NUMBERS.
2. TAG NUMBERS MODIFIED FOR DRAWING USE AS FOLLOWS:
TAG #1: 2-NSW-VIC-0-W APPEARS AS: NSW00W
3. INSTRUMENT ROOT VALVE MARKINGS NOT SHOWN ON DRAWING (SEE VALVE IDENTIFICATION LIST) DERIVED BY ADDING TO INSTRUMENT NUMBER: FOR SINGLE IMPLUSCT; FOR DOUBLE IMPLUSCT; VALVE STREAMLINE V200WSTW

DATE	NO.	REV.	BY
1-21-85	22	Rev	SHH

FOR REVISION DESCRIPTION SEE SEPARATE REVISION RECORD FOR THIS DRAWING

INDIANA & MICHIGAN ELECTRIC CO.
DONALD C. COOK
NUCLEAR PLANT

FLOW DIAGRAM
STATION DRAINAGE
CONTAINMENT
UNIT NO. 1

DWG. NO.	1-5124-22
DATE	1-21-85
NO. OF SHEETS	22
SHEET NO.	22
DESIGNED BY	DRG
CHECKED BY	DRG
APPROVED BY	DRG
DATE	1-21-85
AMERICAN ELECTRIC POWER SERVICE CO.	2 BROADWAY NEW YORK

NOTE!
FOR REFUELING CAVITY DRAINAGE, SEE SPENT FUEL PIT COOLING & CLEAN-UP DIAGRAM DWG 5136

SI
APERTURE
CARD

Also Available
Aperture Ca

9003090184-08

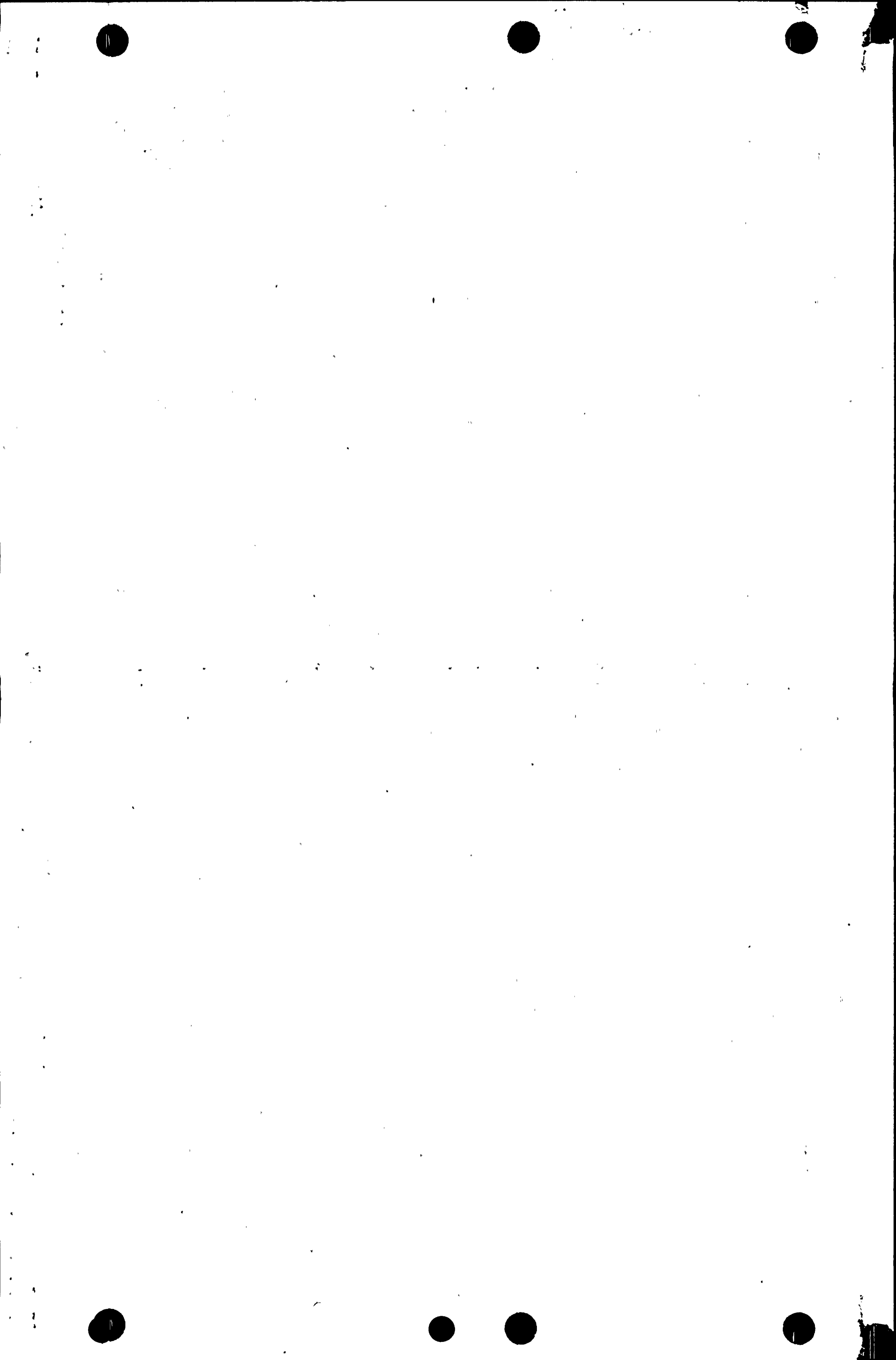

8219-1

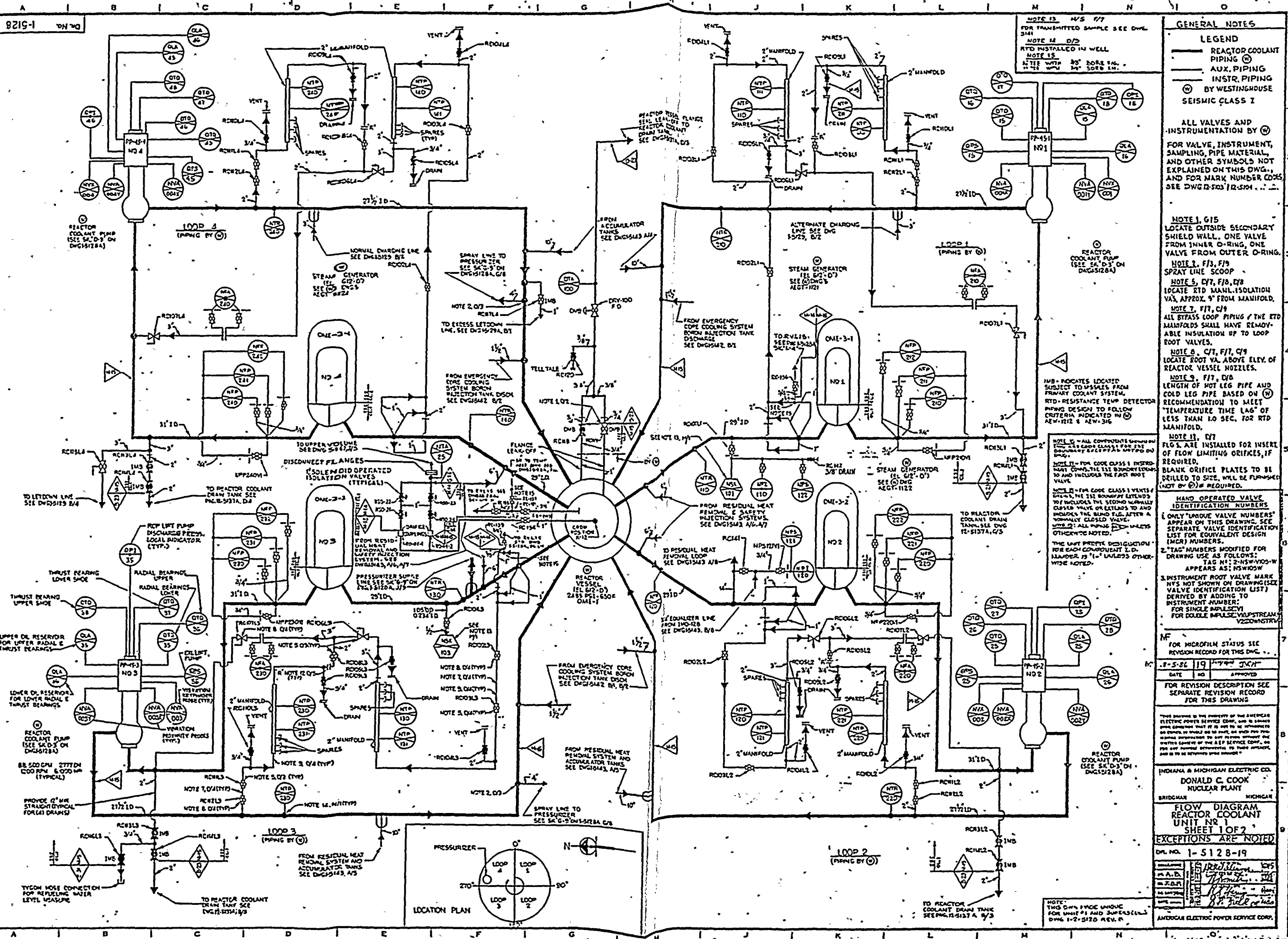

GENERAL NOTES

LEGEND

— REACTOR COOLANT PIPING (C)

— AUX. PIPING (A)

— INSTR. PIPING (I)

⊙ BY WESTINGHOUSE

SEISMIC CLASS 1

ALL VALVES AND INSTRUMENTATION BY (W)

FOR VALVE, INSTRUMENT, SAMPLING, PIPE MATERIAL, AND OTHER SYMBOLS NOT EXPLAINED ON THIS DWG., AND FOR MARK NUMBER CODES SEE DWG 12-503/12-504...

NOTE 1, G15
LOCATE OUTSIDE SECONDARY SHIELD WALL. ONE VALVE FROM INNER O-RING, ONE VALVE FROM OUTER O-RING.

NOTE 2, F13, F19
SPRAY LINE SCOOP

NOTE 3, D17, F18, D18
LOCATE RTD MANIF. ISOLATION VALV, APPROX. 5' FROM MANIFOLD.

NOTE 4, F17, C19
ALL BYPASS LOOP PIPING / THE RTD MANIFOLDS SHALL HAVE REMOVABLE INSULATION UP TO LOOP ROOT VALVES.

NOTE 5, C17, F17, C19
LOCATE ROOT VALV. ABOVE ELEV. OF REACTOR VESSEL NOZZLES.

NOTE 6, F17, D18
LENGTH OF HOT LEG PIPE AND COLD LEG PIPE BASED ON (W) RECOMMENDATION TO MEET "TEMPERATURE TIME LAG" OF LESS THAN 1.0 SEC. FOR RTD MANIFOLD.

NOTE 7, D17
FLGS. ARE INSTALLED FOR INSERT OF FLOW LIMITING ORIFICES, IF REQUIRED. BLANK ORIFICE PLATES TO BE DRILLED TO SIZE. WLL BE FURNISHED (NOT BY (W)) AS REQUIRED.

HAND OPERATED VALVE IDENTIFICATION NUMBERS
ONLY "IRROQUE VALVE NUMBERS" APPEAR ON THIS DRAWING. SEE SEPARATE VALVE IDENTIFICATION LIST FOR EQUIVALENT DESIGN (MCR) NUMBERS.

"TAG" NUMBERS MODIFIED FOR DRAWING USE AS FOLLOWS:
TAG NO. 2-NSWV105-W APPEARS AS: NSWV105W

INSTRUMENT ROOT VALVE MARK:
NFS NOT SHOWN ON DRAWING (SEE VALVE IDENTIFICATION LIST) DERIVED BY ADDING TO INSTRUMENT NUMBER:
FOR SINGLE IMPULSE: V
FOR DOUBLE IMPULSE: V/STREAM
V/2/STREAM

FOR MICROFILM STATUS SEE REVISION RECORD FOR THIS DWG.

DATE: 1977 JAN
DATE: 1977 JAN

INDIANA & MICHIGAN ELECTRIC CO. DONALD C. COOK NUCLEAR PLANT BRIDGMAN MICHIGAN

FLOW DIAGRAM REACTOR COOLANT UNIT NO. 1 SHEET 1 OF 2

EXCEPTIONS ARE NOTED
DWG. NO. 1-5128-19

AMERICAN ELECTRIC POWER SERVICE CORP.

SI APERTURE CARD

Also Available On Aperture Card

FOR REVISION ONLY NOT A CONTROLLED COPY

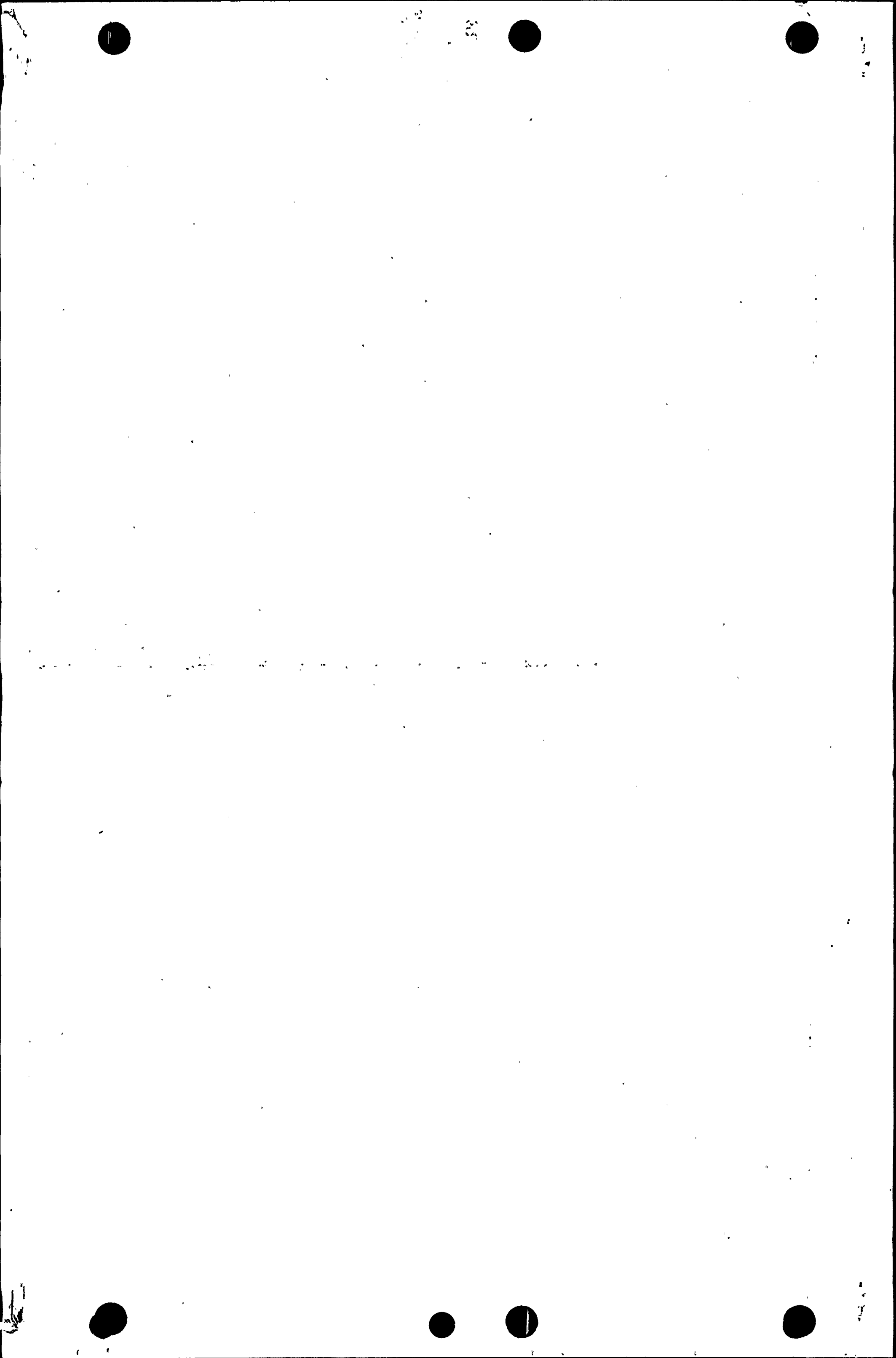

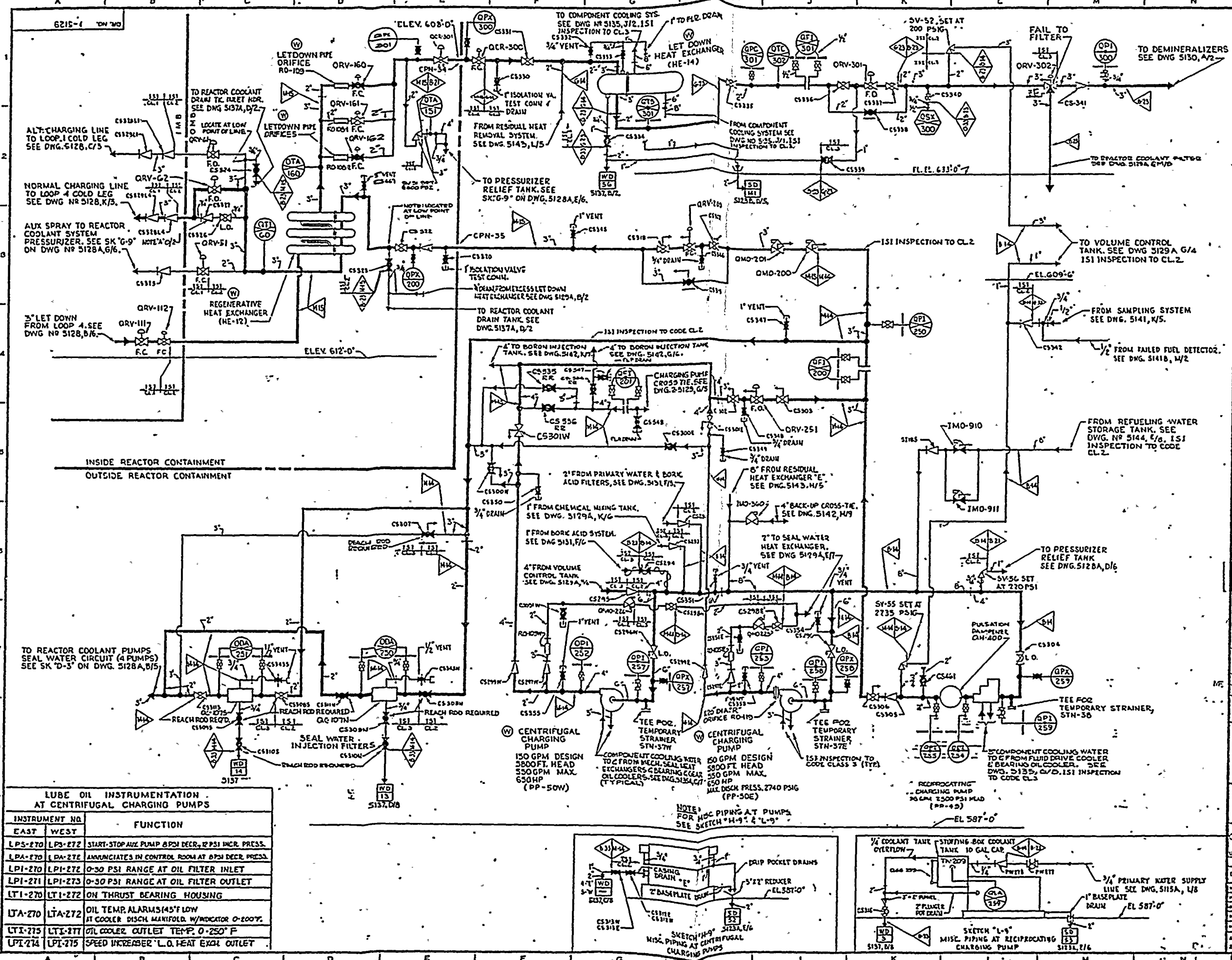

GENERAL NOTES

LEGEND
 — MAIN FLOW
 - - - AUX. FLOW

FOR VALVE, INSTRUMENT, SAMPLING, PIPE MATERIAL AND OTHER SYMBOLS NOT EXPLAINED ON THIS DWG AND FOR MARK NUMBER CODES SEE DWGS. 12-5103 & 12-5104.

SEISMIC CLASS I, EXCEPT AS NOTED

VALVE NOTED "A" B/S VALVE OPENS AT 500 PSID

ALL VALVES, EQUIPMENT & INSTRUMENTATION SUPPLIED BY (C) (WESTINGHOUSE) EXCEPT AS NOTED:

1. FOR CODE CLASS 2 & 3 INSTRUMENT CONNECTIONS, THE IS1 BOUNDARY EXTENDS TO AND INCLUDES THE FIRST ROOF VALVE.

2. FOR CODE CLASS 2 & 3 VENTS IN DRAINS, THE IS1 BOUNDARY EXTENDS TO & INCLUDES THE FIRST NORMALLY CLOSED VALVE.

3. R.R. INDICATES REACH ROD REQUIRED.

4. THE UNIT PREFIX DESIGNATION FOR EACH COMPONENT IDENTIFICATION NUMBER IS "1" UNLESS OTHERWISE NOTED.

NOTE: THIS DWG MADE UNIQUE FOR UNIT "1" AND SUPERSEDES DWG. 1-2-5129 REV. 1

HAND OPERATED VALVE IDENTIFICATION NUMBERS
 ONLY "UNIQUE VALVE NUMBERS" APPEAR ON THIS DRAWING. SEE SEPARATE VALVE IDENTIFICATION LIST FOR EQUIVALENT DESIGN (MCR) NUMBERS.
 2" TAG NUMBERS MODIFIED FOR DRAWING USE AS FOLLOWS:
 TAG NO. 2-NW-V003-W APPEARS AS "NW003"

INSTRUMENT ROOT VALVE MARKS NOT SHOWN ON DRAWING (SEE VALVE IDENTIFICATION LIST) DERIVED BY ADDING TO INSTRUMENT NUMBER FOR SINGLE IMPULSE: "V" FOR DOUBLE IMPULSE: "V2" STREAM: "V2D" DOWNSTREAM: "V2D2"

"M" FOR MICROFILM STATUS SEE REVISION RECORD FOR THIS DWG.

DATE: 11-11-87 131
 NO. 251
 APPROVED

FOR REVISION DESCRIPTION SEE SEPARATE REVISION RECORD FOR THIS DRAWING

INDIANA & MICHIGAN ELECTRIC CO.
 DONALD C. COOK
 NUCLEAR PLANT

BRIDGEMAN MICHIGAN

**FLOW DIAGRAM
 CVCS-REACTOR LETDOWN
 & CHARGING**
 UNIT # 1
 SHEET 1 OF 2

DR. NO. 1-5129-31

AMERICAN ELECTRIC POWER SERVICE CORP., 2 BROADWAY, NEW YORK

LUBE OIL INSTRUMENTATION AT CENTRIFUGAL CHARGING PUMPS

INSTRUMENT NO.	EAST	WEST	FUNCTION
LPS-270	LPS-272		START-STOP AUX PUMP @ PSI DECR., 12 PSI INCR. PRESS.
LPA-270	LPA-272		ANNUNCIATES IN CONTROL ROOM AT 8 PSI DECR. PRESS.
LPI-270	LPI-272		0-30 PSI RANGE AT OIL FILTER INLET
LPI-271	LPI-273		0-30 PSI RANGE AT OIL FILTER OUTLET
LT1-270	LT1-272		ON THRUST BEARING HOUSING
LTA-270	LTA-272		OIL TEMP. ALARMS (45°F LOW AT COOLER DISCH. MANIFOLD, W/INDICATOR 0-200°F.
LTI-275	LTI-277		OIL COOLER OUTLET TEMP. 0-250°F
LPI-274	LPI-275		SPEED INCREASER L.O. HEAT EXCH. OUTLET

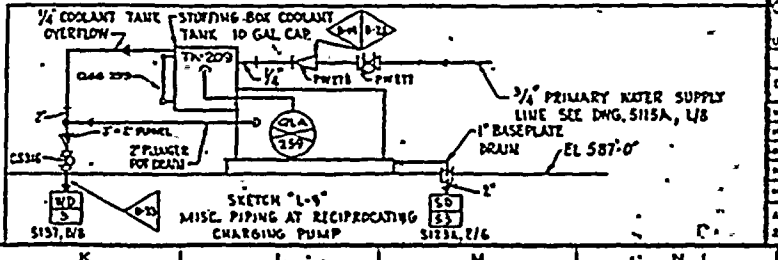
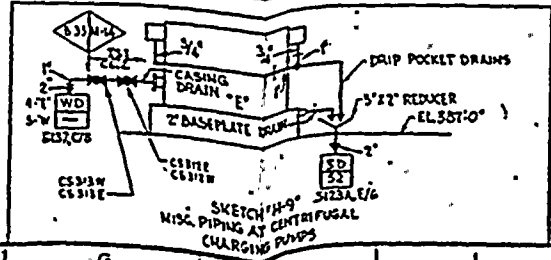

SI
 APERTURE
 CARD

Also Available On
 Aperture Card

NOT A CONTROLLED COPY

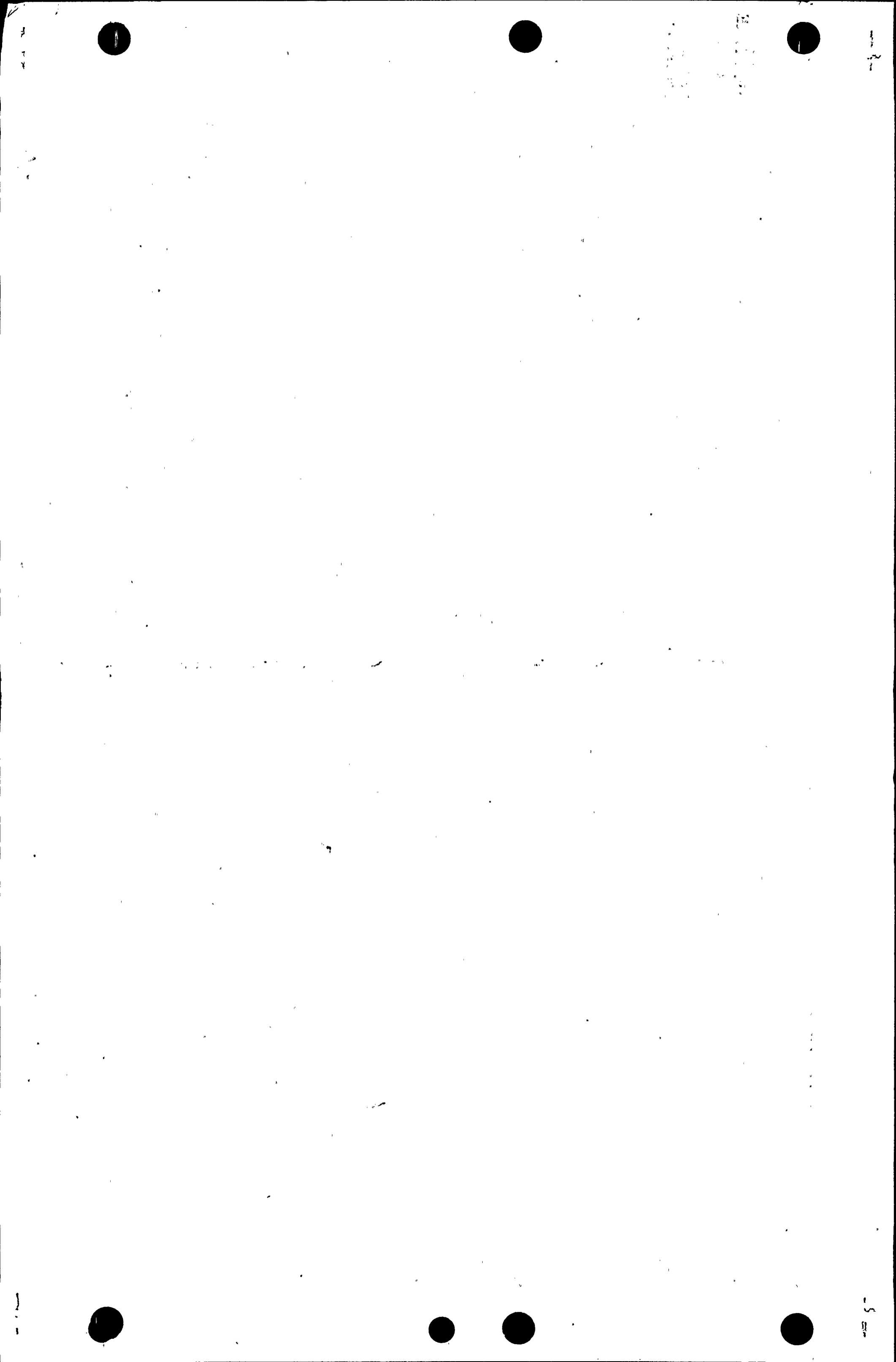

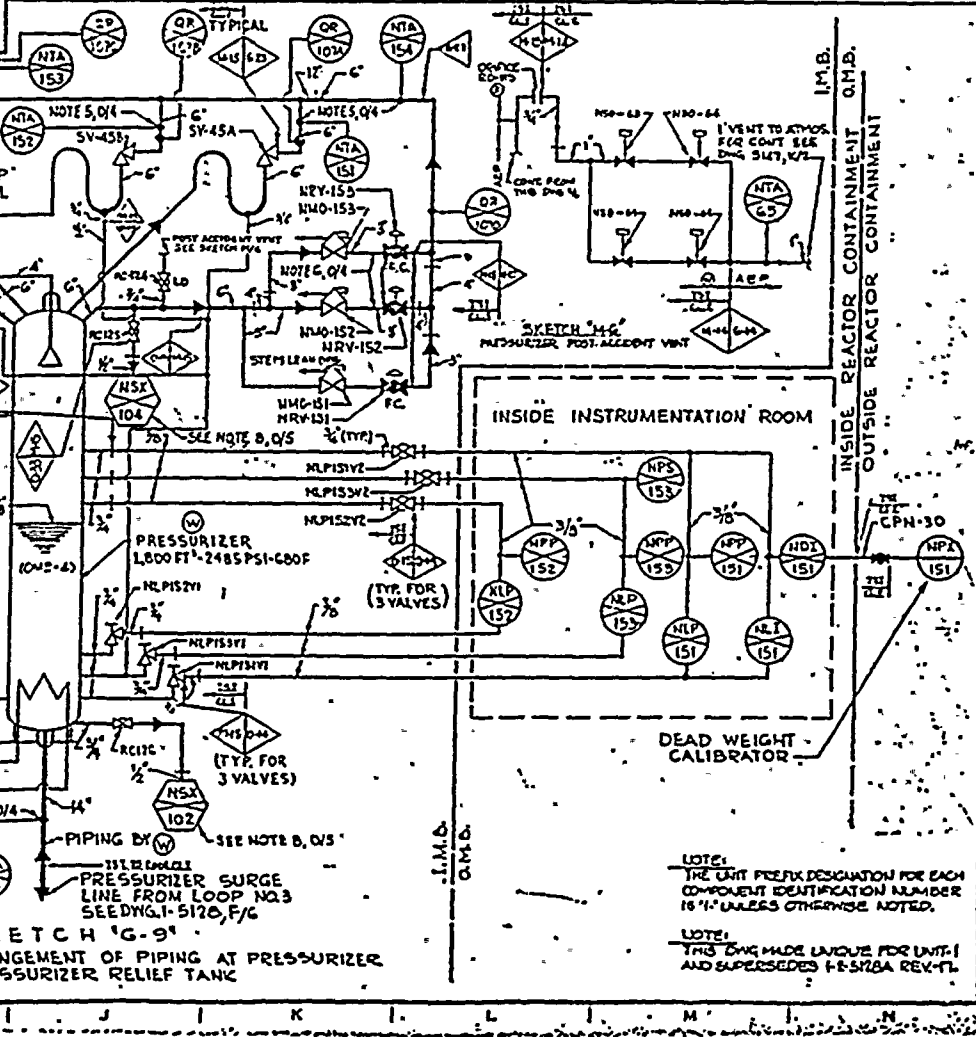
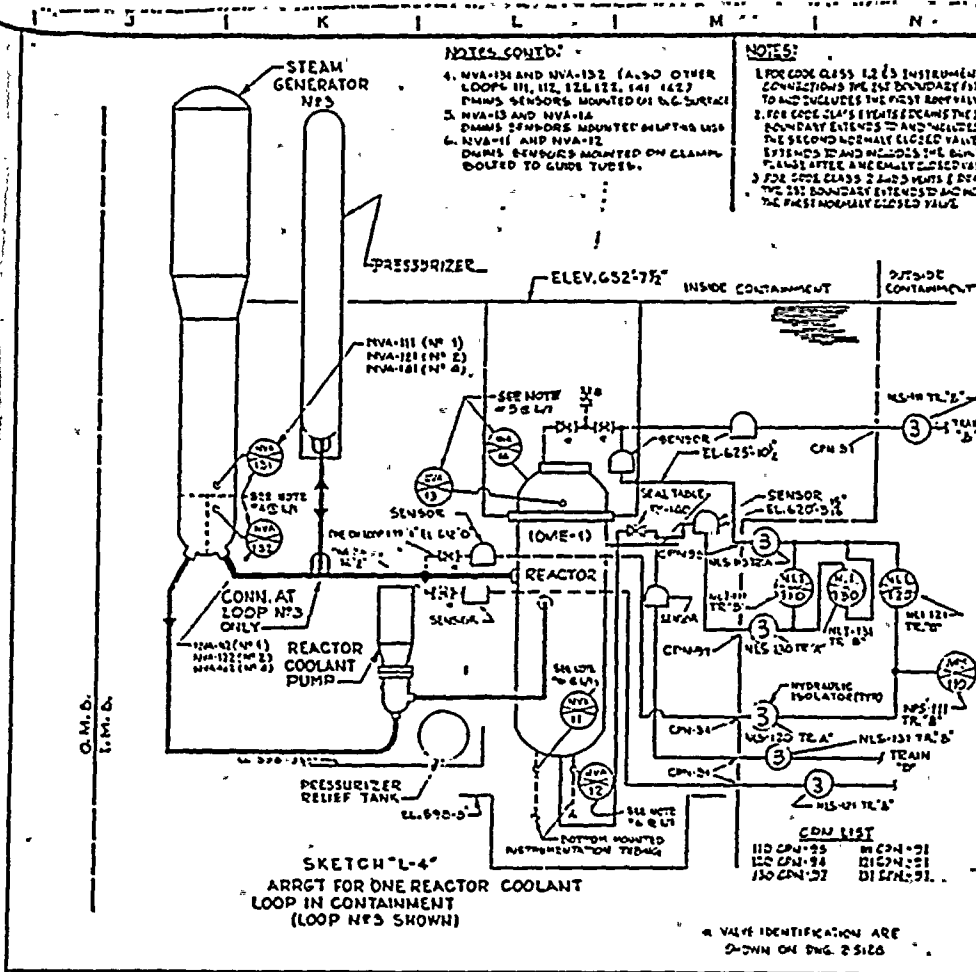
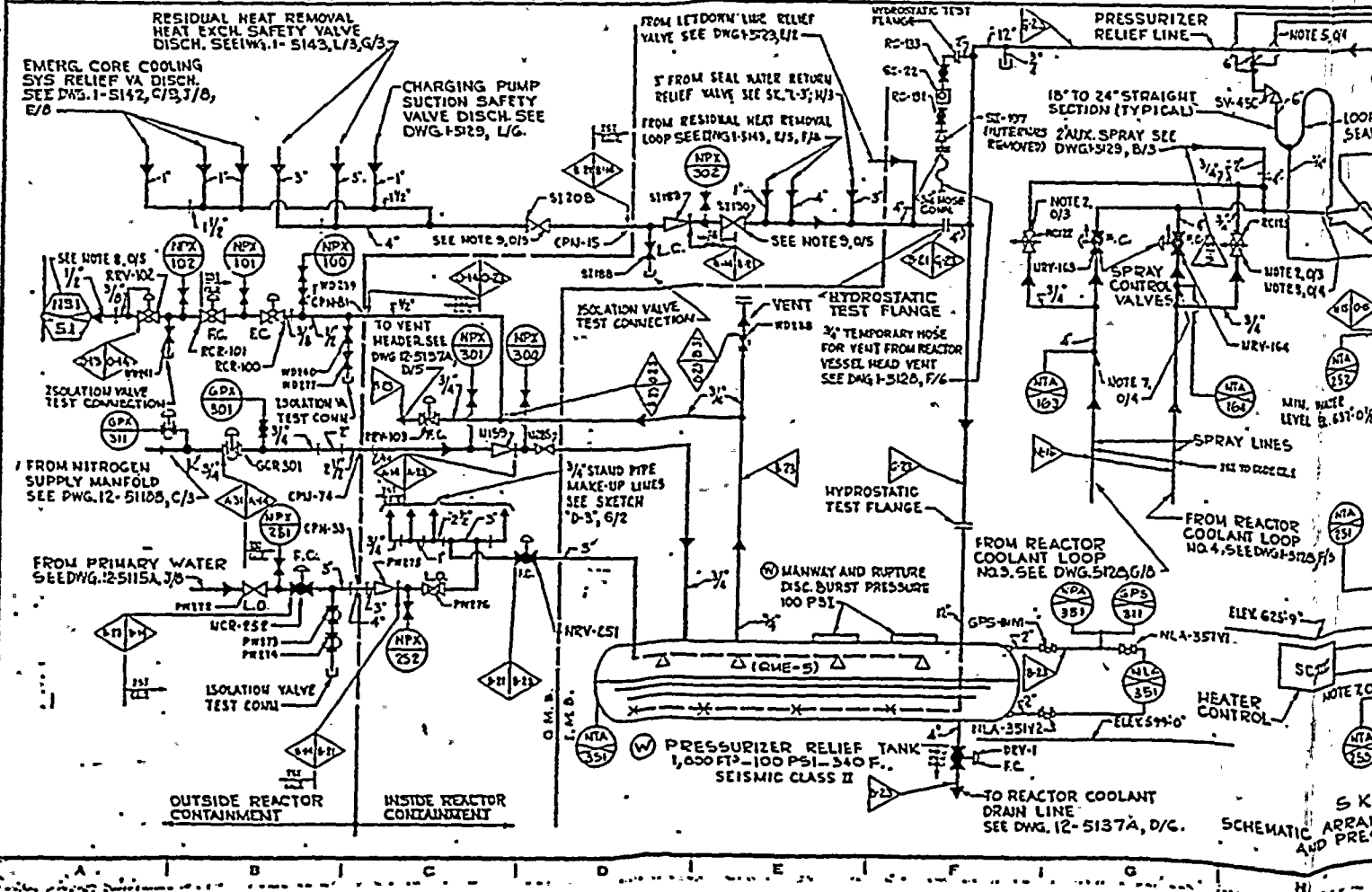
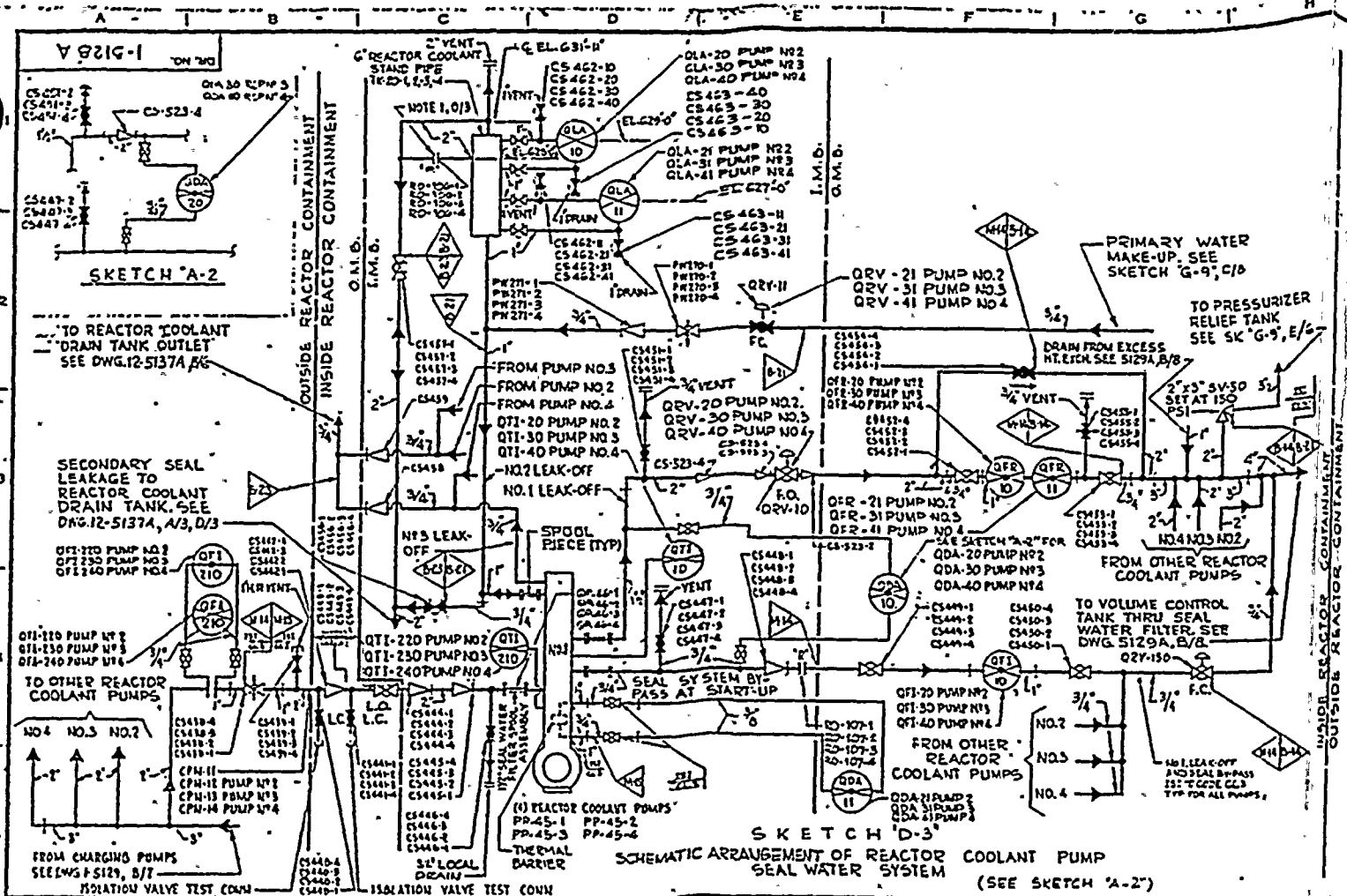

GENERAL NOTES

LEGEND

- REACTOR COOLANT PIPING BY (M)
- AUX. PIPING INSTR. PIPING BY (W)
- BY WESTINGHOUSE
- XEL VALVES AND INSTRUMENTATION BY (X)

FOR VALVE, INSTRUMENT, SAMPLING, PIPE MATERIAL AND OTHER SYMBOLS NOT EXPLAINED ON THIS DWG., AND FOR MARK NUMBER CODES, SEE DWGS. 12-5103, 5104

NOTE: PIPING DESIGN TO FOLLOW CRITERIA INDICATED IN @AEW-1212 & AEW-316.

NOTE 1, C/I: CRUISE IS A MIN. OF 1 FT. ABOVE THE COOL TO THE REACTOR COOLANT PUMP.

NOTE 2, J/T, W/T: VALVE TO HAVE EXTENSION STEM TO BE OPERATED OUTSIDE OF PRESSURIZER ENCLOSURE AT EL. 612'-0".

NOTE 3, W/T: SLOPE SPRAY PIPE DOWNWARD TO PROVIDE WATER SEAL BETWEEN PRESSURIZER AND SPRAY VALVES.

NOTE 5, W/G, W/G, W/G: PLACE DETECTORS AT BOTTOM OF PIPE.

NOTE 6, W/G: SLOPE PIPE DOWNWARD TO PROVIDE WATER SEAL ON RELIEF VALVES.

NOTE 1, G/T, J/T: LOCATE APPROXIMATELY MIDWAY BETWEEN LOOP AND PRESSURIZER.

NOTE 8, A/T, J/T, J/T: FOR TRANSMITTED SAMPLE SEE DWG. 5141.

NOTE 9, E/T: VALVE BONNET AND INTERNALS ARE TO BE REMOVED AND BLIND HEAD INSTALLED EXCEPT WHEN TESTING VALVE 51189.

HAND OPERATED VALVE IDENTIFICATION NUMBERS:

- 1. ONLY "UNIQUE VALVE NUMBERS" APPEAR ON THIS DRAWING. SEE SEPARATE VALVE IDENTIFICATION LIST FOR EQUIVALENT DESIGN (MCR) NUMBERS.
- 2. TAG NUMBERS MODIFIED FOR THIS DRAWING AS FOLLOWS: TAG NO. 2-NSW-V00-1 APPEARS AS: NSWV00W.
- 3. INSTRUMENT ROOT VALVE MARK. NTS NOT SHOWN ON DRAWING (SEE VALVE IDENTIFICATION LIST) DERIVED BY ADDING TO INSTRUMENT NUMBER: FOR SINGLE IMPULSE (V) STREAM: V2000W001V.

FOR MICROFILM STATUS SEE REVISION RECORD FOR THIS DWG.

DATE: 12-27-57
APPROVED: [Signature]
FOR REVISION DESCRIPTION SEE SEPARATE REVISION RECORD FOR THIS DRAWING.

INDIANA & MICHIGAN ELECTRIC CO.
DONALD C. COOK
NUCLEAR PLANT
BROOKHART, INDIANA

FLOW DIAGRAM REACTOR COOLANT UNIT SHEET 2 OF 2

DWG. NO. 1-5128 A-37

NOTES:

THE UNIT PREFIX DESIGNATION FOR EACH COMPONENT IDENTIFICATION NUMBER IS "U" UNLESS OTHERWISE NOTED.

THIS DWG. MADE LAURE FOR UNIT 1 AND SUPERSEDES 1-5128A REV. 1.

SI APERTURE CARD

Also Available On Aperture Card

NOT A CONTROL COPY

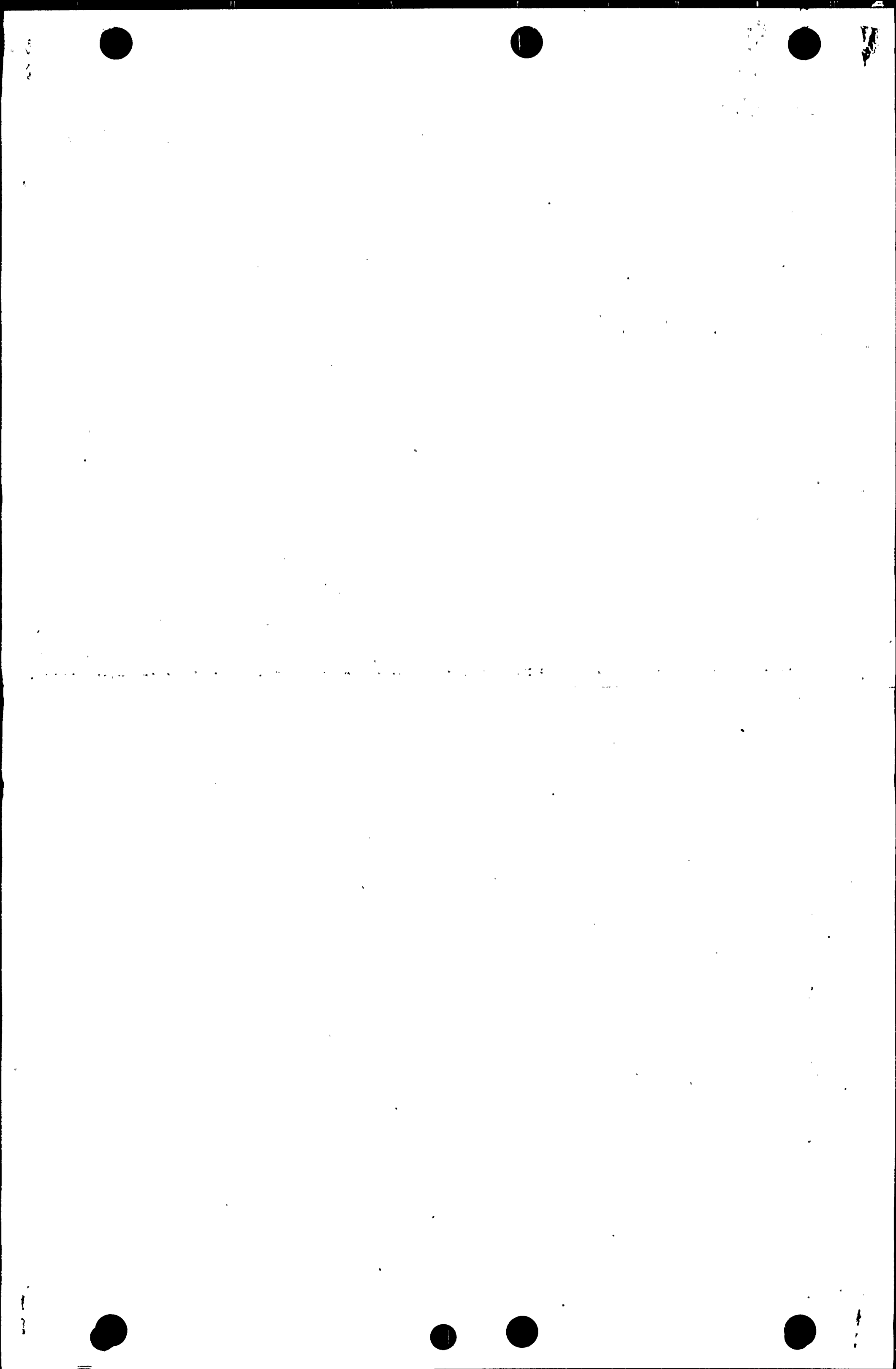

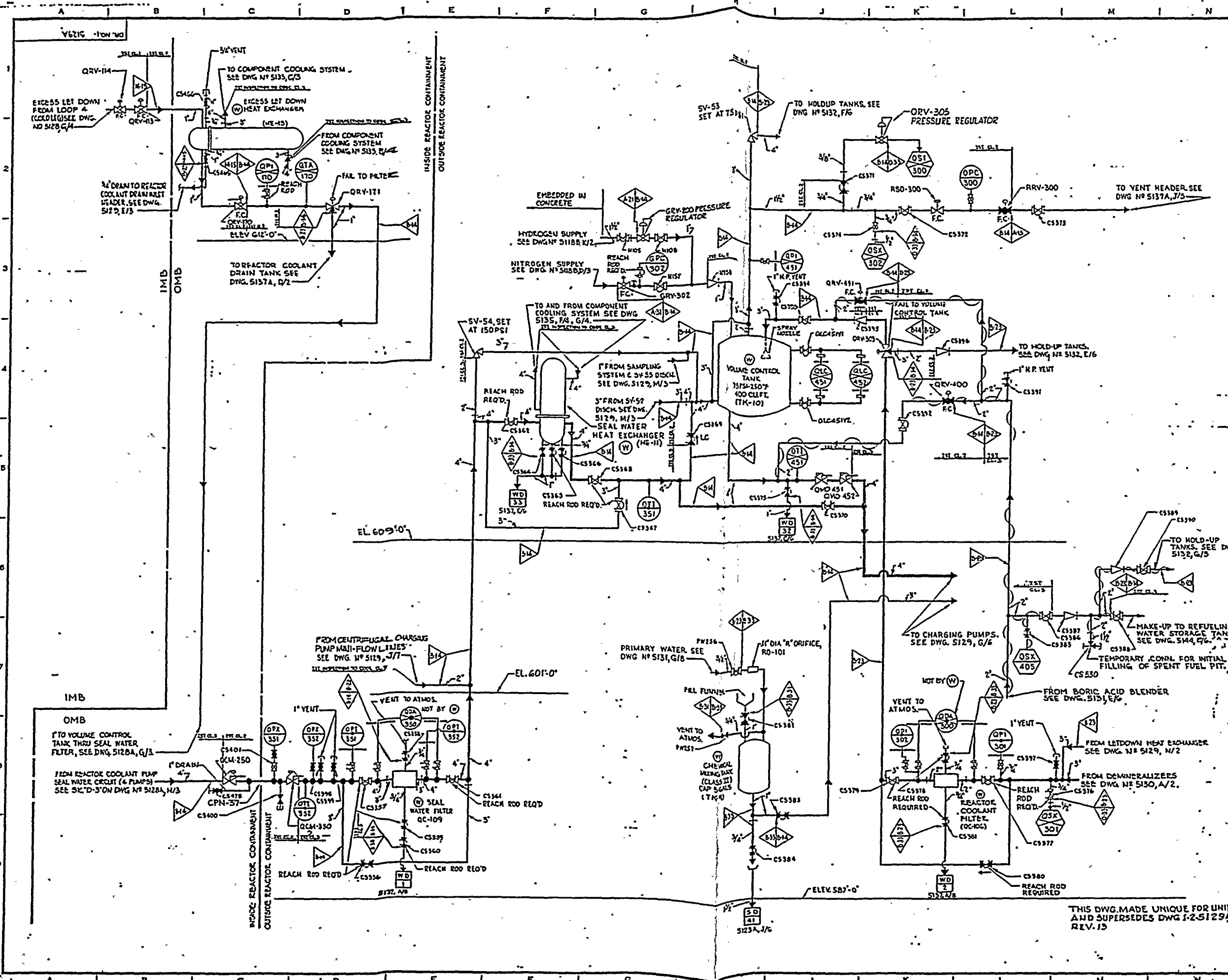

GENERAL NOTES

LEGEND

— MAIN FLOW
 - - - - - AUX. FLOW

FOR VALVE, INSTRUMENT, SAMPLING, PIPE MATERIAL AND OTHER SYMBOLS NOT EXPLAINED ON THIS DWG AND FOR MARK NUMBER CODES SEE DWGS. 12-5103 & 12-5104.

SEISMIC CLASS I EXCEPT AS NOTED

⊙ BY WESTINGHOUSE

ALL VALVES, EQUIPMENT & INSTRUMENTATION SUPPLIED BY ⊙, EXCEPT AS NOTED.

NOTES:

1. FROM COOL. CL. 213 INSTRUMENT COMP. THE 121 ISOLATION LITERS TO INCLUDE THE FIRST ROOT VALVE.

2. FROM COOL. CL. 213 MULTI-DRAWING THE 121 ISOLATION TO INCLUDE THE FIRST NORMALLY CLOSED VALVE.

THE LAST PREFIX DESIGNATION FOR EACH COMPONENT I.D. NUMBER IS *1- UNLESS OTHERWISE NOTED.

HAND OPERATED VALVE IDENTIFICATION NUMBERS

1. ONLY "UNIQUE VALVE NUMBERS" APPEAR ON THIS DRAWING. SEE SEPARATE VALVE IDENTIFICATION LIST FOR EQUIVALENT DESIGN (MCR) NUMBERS.

2. TAG NUMBERS MODIFIED FOR DRAWING USE AS FOLLOWS:
 TAG #1: 2-NSW-V05-W APPEARS AS: NSW125W

3. INSTRUMENT ROOT VALVE MARK #1'S NOT SHOWN ON DRAWING (SEE VALVE IDENTIFICATION LIST) DERIVED BY ADDING TO INSTRUMENT NUMBER:
 FOR SINGLE IMPULSE: V200W125TRM
 FOR DOUBLE IMPULSE: V200W125TRM

FOR MCR/FORM STATUS SEE REVISION RECORD FOR THIS DWG.

DATE: 5-27-87
 NO. 19
 APPROVED: [Signature]

FOR REVISION DESCRIPTION SEE SEPARATE REVISION RECORD FOR THIS DRAWING.

INDIANA & MICHIGAN ELECTRIC CO.,
 "DONALD C. COOK
 NUCLEAR PLANT

BRIDGEMAN MICHIGAN
**FLOW DIAGRAM
 CVCS-REACTOR LETDOWN
 & CHARGING**

SHEET 2012

DWG. NO. 1- 5129A-19

THIS DWG. MADE UNIQUE FOR UNIT #1 AND SUPERSEDES DWG. 1-2-5129A REV. 15

SI
 APERTURE
 CARD

Also Available On
 Aperture Card

FOR REVISION ONLY
 NOT A CONTROLLED COPY

9003090184-12

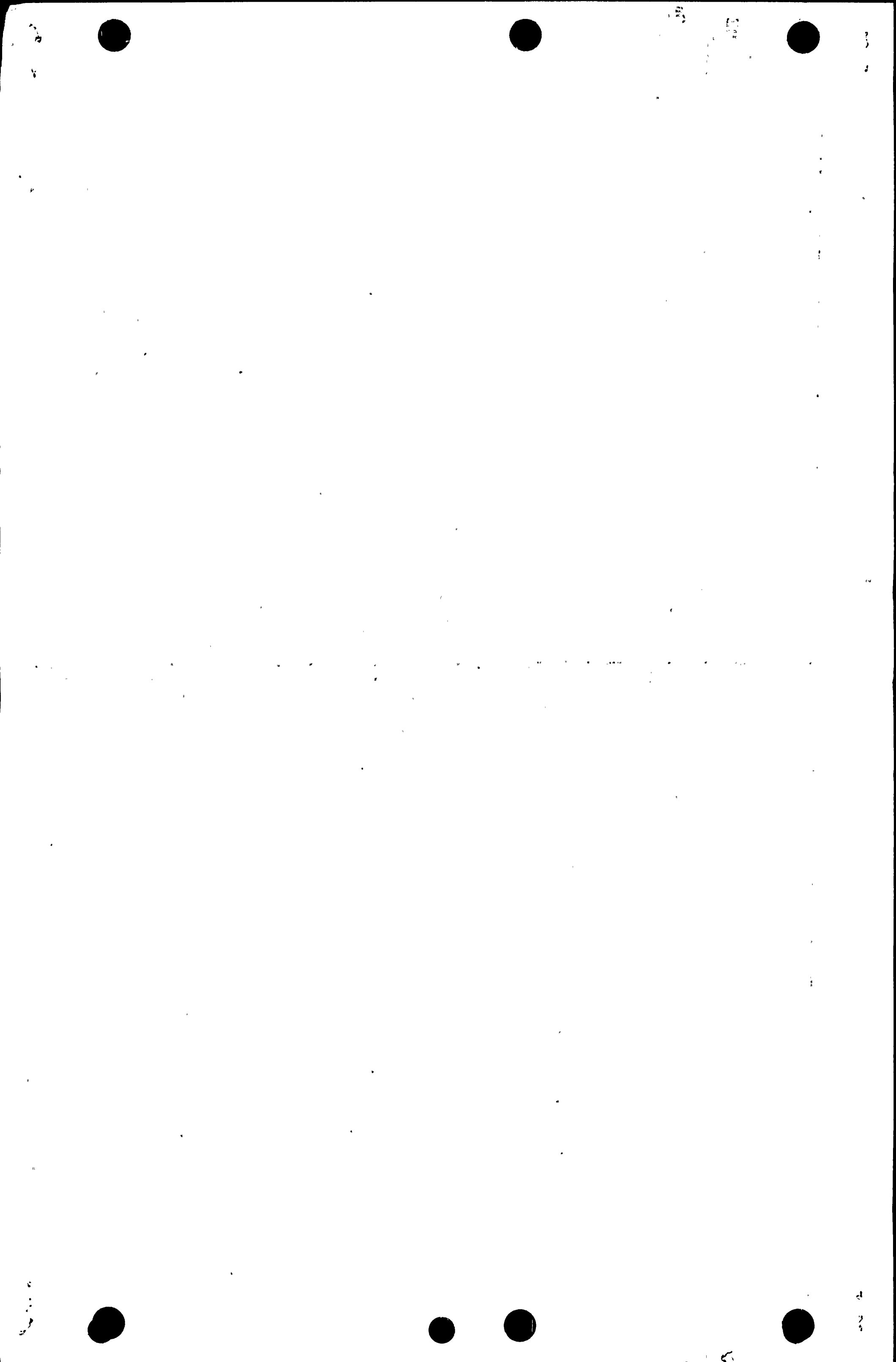

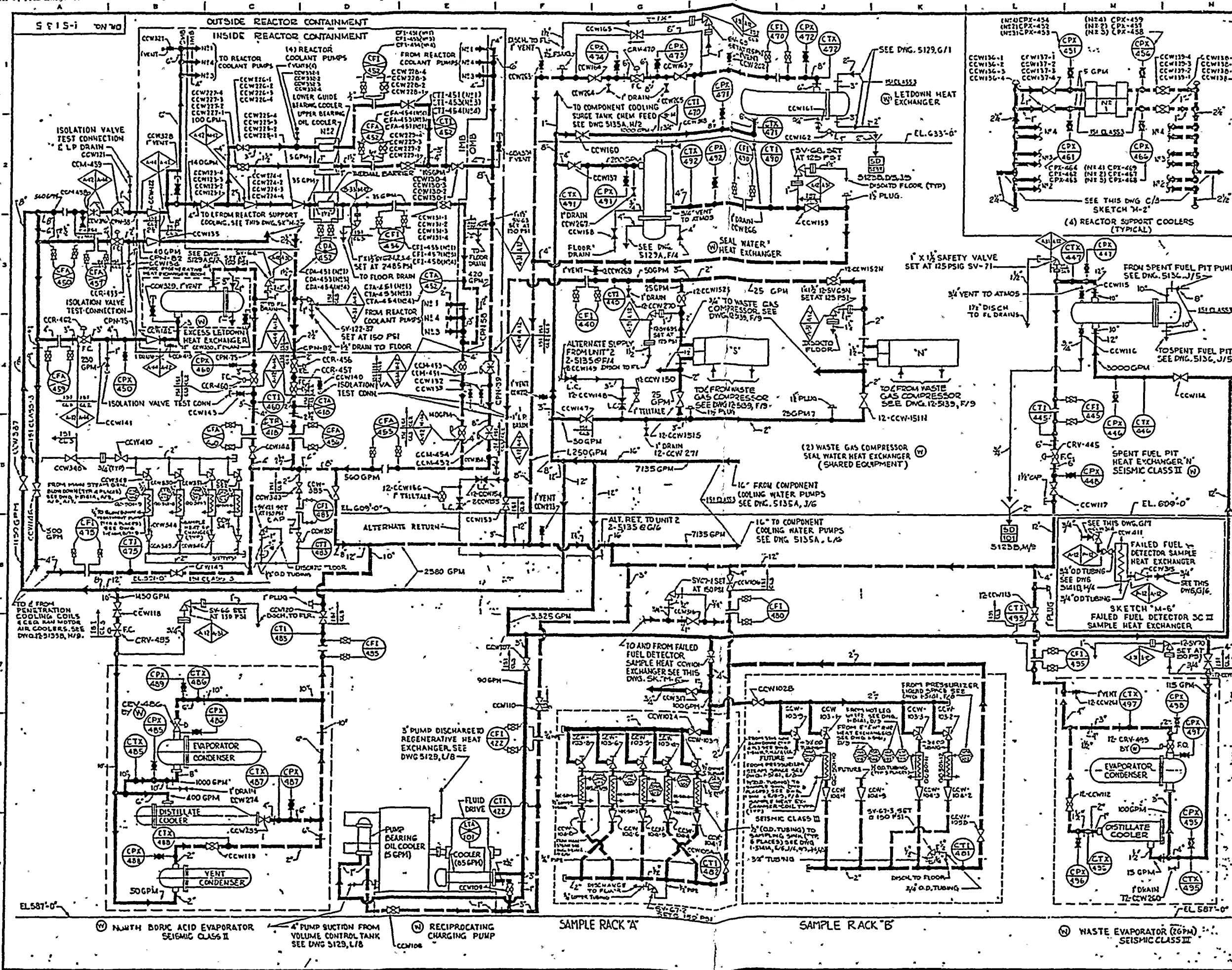

GENERAL NOTES

LEGEND

- COMPONENT COOLING SUPPLY
- COMPONENT COOLING RETURN
- AUXILIARY PIPING

FOR VALVE, INSTRUMENT, SAMPLING, PIPE MATERIAL AND OTHER SYMBOLS NOT EXPLAINED ON THIS DWG, AND FOR MARK NUMBER CODES, SEE DWG 5104

(W) BY WESTINGHOUSE

EQUIPMENT SUPPLIED BY (M) AS NOTED

ALL PIPING TO BE CLASS A-12

ALL TUBING TO BE CLASS P-42 EXCEPT AS NOTED

ALL EQUIPMENT SEISMIC CLASS I EXCEPT AS NOTED

(D) FOR CODE CLASS 2 AND 3 INSTR. CONNECTIONS THE 151 BOUNDARY EXTENDS TO AND INCLUDES THE FIRST ROOT VALVE.

(E) FOR CODE CLASS 2 (3) VENTS & DRAINS THE 151 BOUNDARY EXTENDS TO AND INCLUDES THE FIRST WALL-CLOSED VALVE.

THE UNIT PREFIX DESIGNATION FOR EACH COMPONENT IDENTIFICATION NUMBER IS "1" UNLESS OTHERWISE NOTED.

NOTE

THIS DWG MADE UNIQUE FOR UNIT #1 AND SUPERSEDES DWG. 1-2-5135 REV. 17

HAND OPERATED VALVE IDENTIFICATION NUMBERS

1. ONLY "UNIQUE VALVE NUMBERS" APPEAR ON THIS DRAWING. SEE SEPARATE VALVE IDENTIFICATION LIST FOR EQUIVALENT DESIGN (MCR) NUMBERS.

2. "TAG" NUMBERS MODIFIED FOR DRAWING USE AS FOLLOWS: TAG NO. 2-NW100-W APPEARS AS: 2-NW100-W

3. INSTRUMENT ROOT VALVE MARK NYS NOT SHOWN ON DRAWING (SEE VALVE IDENTIFICATION LIST) DERIVED BY ADDING TO INSTRUMENT NUMBER: 1. FOR SINGLE INSTRUMENT FOR DOUBLE IMPULSE VALVE STREAM VZDOWNSTREAM

FOR MICROFILM STATUS SEE REVISION RECORD FOR THIS DWG

DATE NO. APPROVED

FOR REVISION DESCRIPTION SEE SEPARATE REVISION RECORD FOR THIS DRAWING

"This drawing is the property of the American Electric Power Service Corp. and is loaned to the customer. It shall be held in confidence and shall not be reproduced or transmitted in any form or by any means, electronic, mechanical, photocopying, recording, or by any information storage and retrieval system, without the prior written permission of the American Electric Power Service Corp. and it is to be returned upon request."

INDIANA & MICHIGAN ELECTRIC CO.
DONALD C. COOK
NUCLEAR PLANT

FLOW DIAGRAM COMPONENT COOLING UNIT NO. 1 SHEET 1 OF 3

DR. NO. 1-5135-29

AMERICAN ELECTRIC POWER SERVICE CORP.
2 BROADWAY NEW YORK

SI APERTURE CARD

Also Available On Aperture Card

NOT A CONTROLLED COPY

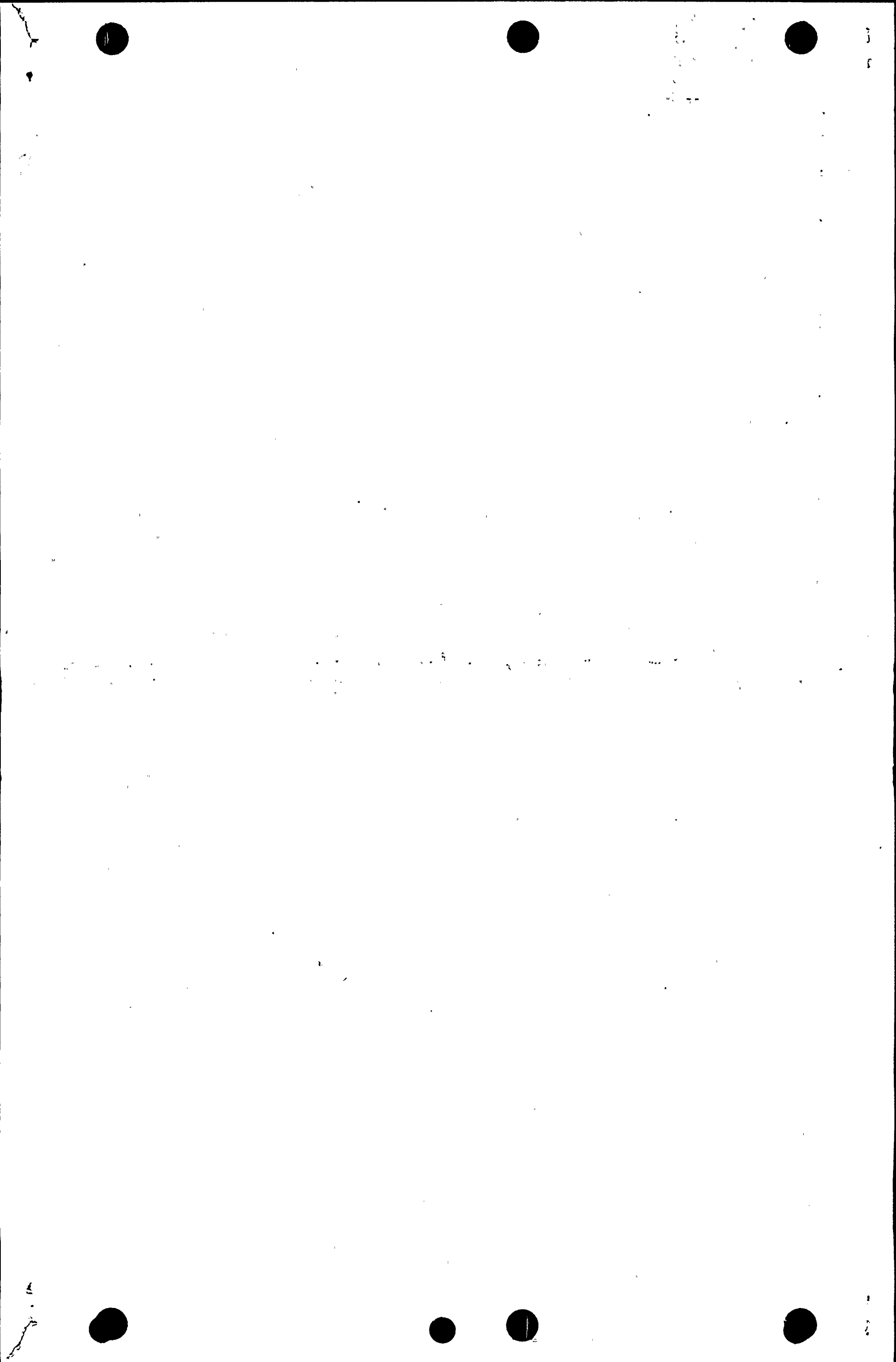

Y5615-1 ON NO

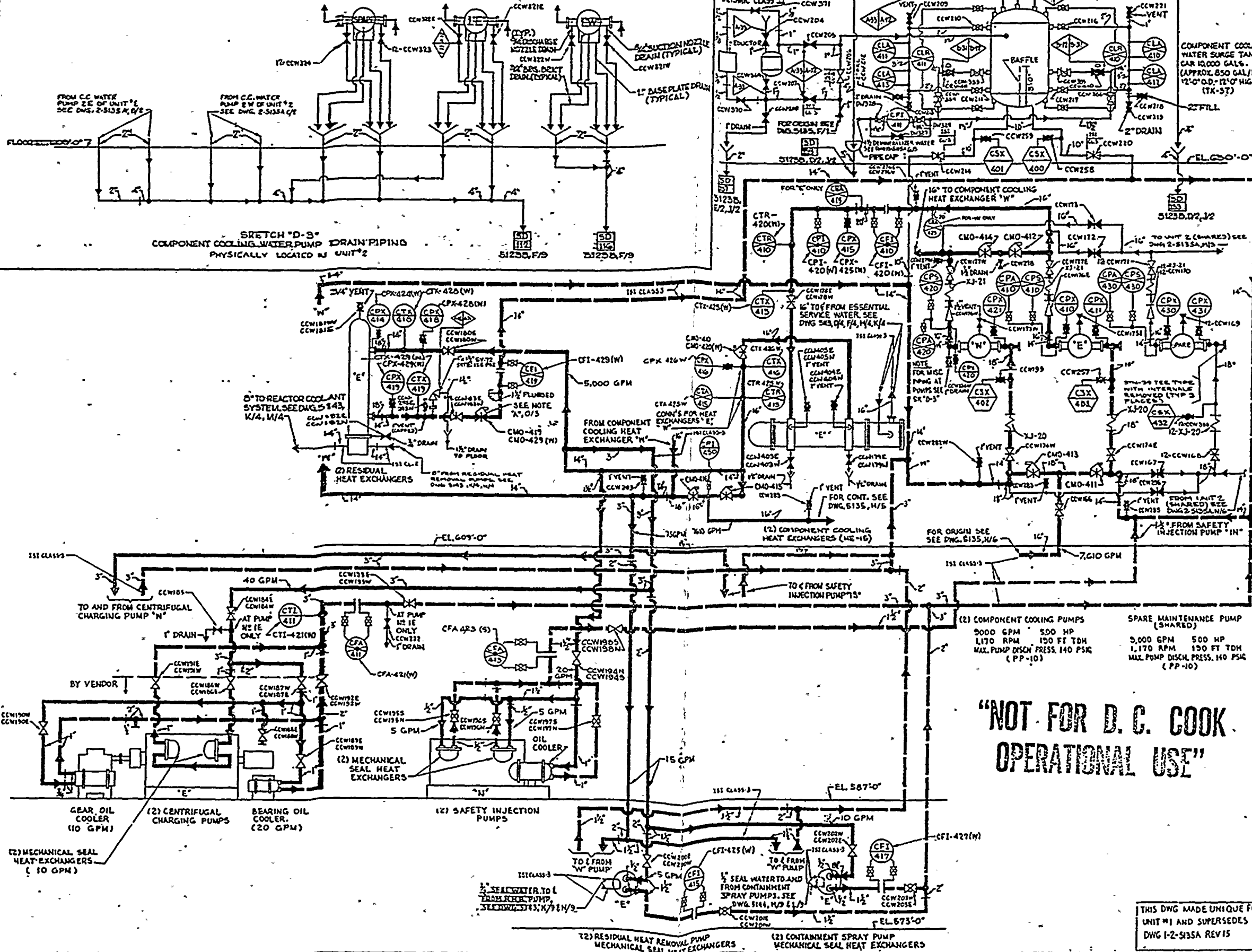

SKETCH "D-3" COMPONENT COOLING WATER PUMP DRAIN PIPING PHYSICALLY LOCATED IN UNIT #2

GENERAL NOTES

- LEGEND**
- COMPONENT COOLING SUPPLY
 - COMPONENT COOLING RETURN
 - AUXILIARY PIPING
- FOR VALVE, INSTRUMENT SAMPLING, PIPE MATERIAL AND OTHER SYMBOLS NOT EXPLAINED ON THIS DWG., AND FOR MARK NUMBER CODES, SEE DWG. 5104
- BY WESTINGHOUSE EQUIPMENT SUPPLIED BY AS NOTED
- ALL PIPING TO BE EXCEPT AS NOTED
- ALL EQUIPMENT SEISMIC CLASS I EXCEPT AS NOTED
- NOTE: A-429 TO HAVE INTERMEDIATE LIMIT SWITCH TO LIMIT FLOW ON SAFETY INJECTION SIGNAL
- NOTE: FOR LOCUS 3 INSTRUMENT CONNECTIONS, THE INSTRUMENT EXTENDS TO AND INCLUDES THE FIRST ROOT VALVE. FOR LOCUS 3 VENTS AND DRAINS THE EXTENSION EXTENDS TO AND INCLUDES THE FIRST CLOSURE VALVE.
- THE UNIT PREFIX DESIGNATION FOR EACH COMPONENT IDENTIFICATION NUMBER IS "15" UNLESS OTHERWISE NOTED.
- HAND OPERATED VALVE IDENTIFICATION NUMBERS**
1. ONLY "UNIQUE VALVE NUMBERS" APPEAR ON THIS DRAWING. SEE SEPARATE VALVE IDENTIFICATION LIST FOR EQUIVALENT DESIGN (HIC) NUMBERS.
 2. "TAG" NUMBERS MODIFIED FOR DRAWING USE AS FOLLOWS:
TAG # 2-NSW-VI05-W APPEARS AS: NSWVI05W
 3. INSTRUMENT ROOT VALVE MARK # IS NOT SHOWN ON DRAWING (SEE VALVE IDENTIFICATION LIST) DERIVED BY ADDING TO INSTRUMENT NUMBER:
FOR SINGLE IMPULSE: VNSWVIA04
FOR DOUBLE IMPULSE: VNSWVIA04
- MF FOR MICROFILM STATUS SEE REVISION RECORD FOR THIS DWG.
- 3-11-86 [Signature] DATE NO. APPROVED
- FOR REVISION DESCRIPTION SEE SEPARATE REVISION RECORD FOR THIS DRAWING
- "THIS DRAWING IS THE PROPERTY OF THE AMERICAN ELECTRIC POWER SERVICE CORP. AND IS LOANED TO YOU BY THE AMERICAN ELECTRIC POWER SERVICE CORP. IT IS TO BE RETURNED TO THE AMERICAN ELECTRIC POWER SERVICE CORP. AT THE END OF THE LOAN PERIOD. IT IS NOT TO BE REPRODUCED, COPIED, OR IN ANY MANNER DISSEMINATED TO ANY OTHER PERSON OR ORGANIZATION WITHOUT THE WRITTEN CONSENT OF THE AMERICAN ELECTRIC POWER SERVICE CORP. AND IS TO BE RETURNED TO THE AMERICAN ELECTRIC POWER SERVICE CORP. AT THE END OF THE LOAN PERIOD."
- INDIANA & MICHIGAN ELECTRIC CO.
DONALD C. COOK
NUCLEAR PLANT
- FLOW DIAGRAM
COMPONENT COOLING
UNIT-NR 1
SHEET 2 OF 3
- DR. NO. 1-5135A-30
- THIS DWG MADE UNIQUE FOR UNIT #1 AND SUPERSEDES DWG 1-2-5135A REV 15

"NOT FOR D. C. COOK OPERATIONAL USE"

SI APERTURE CARD Also Available On Aperture Card

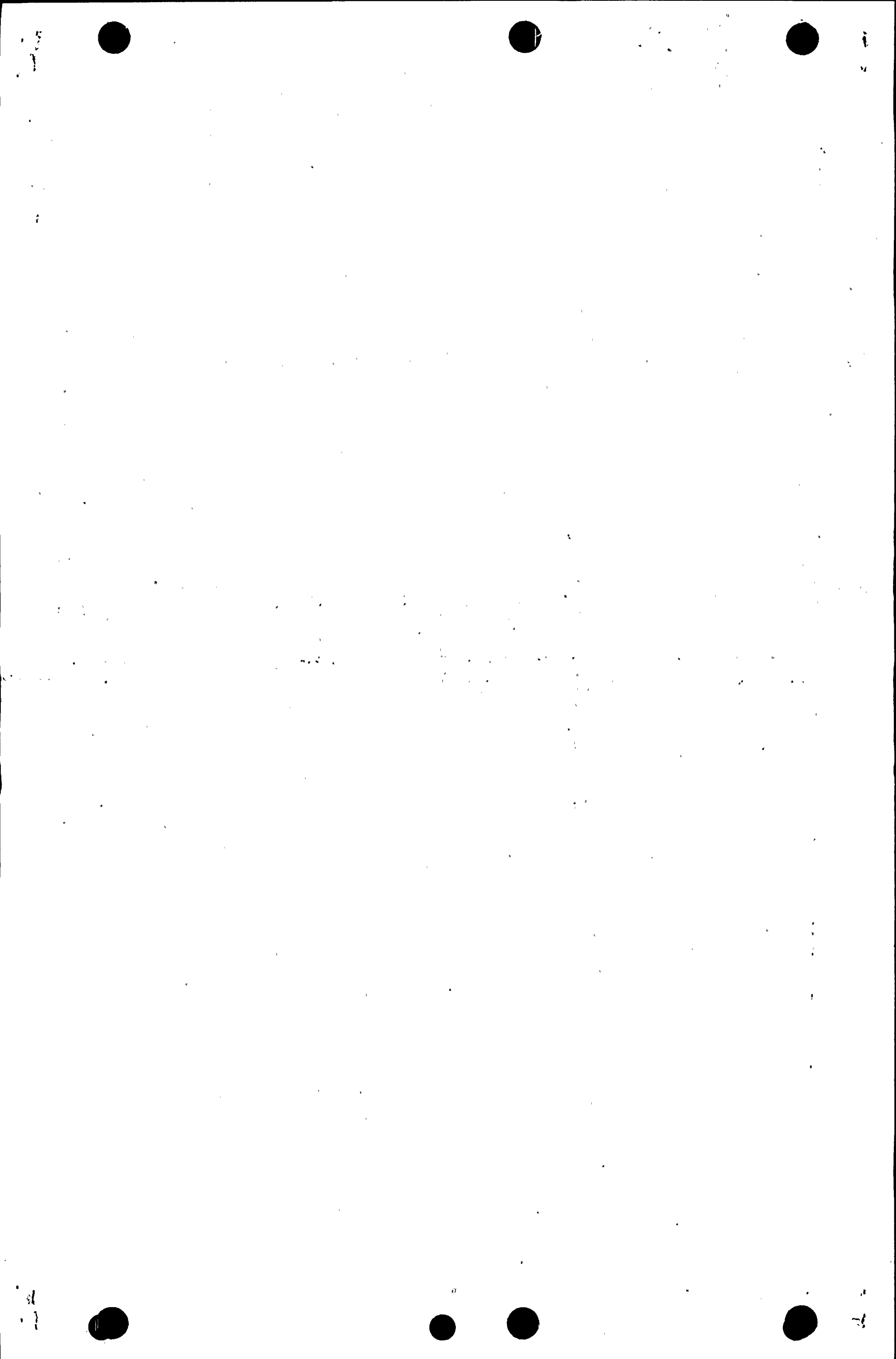

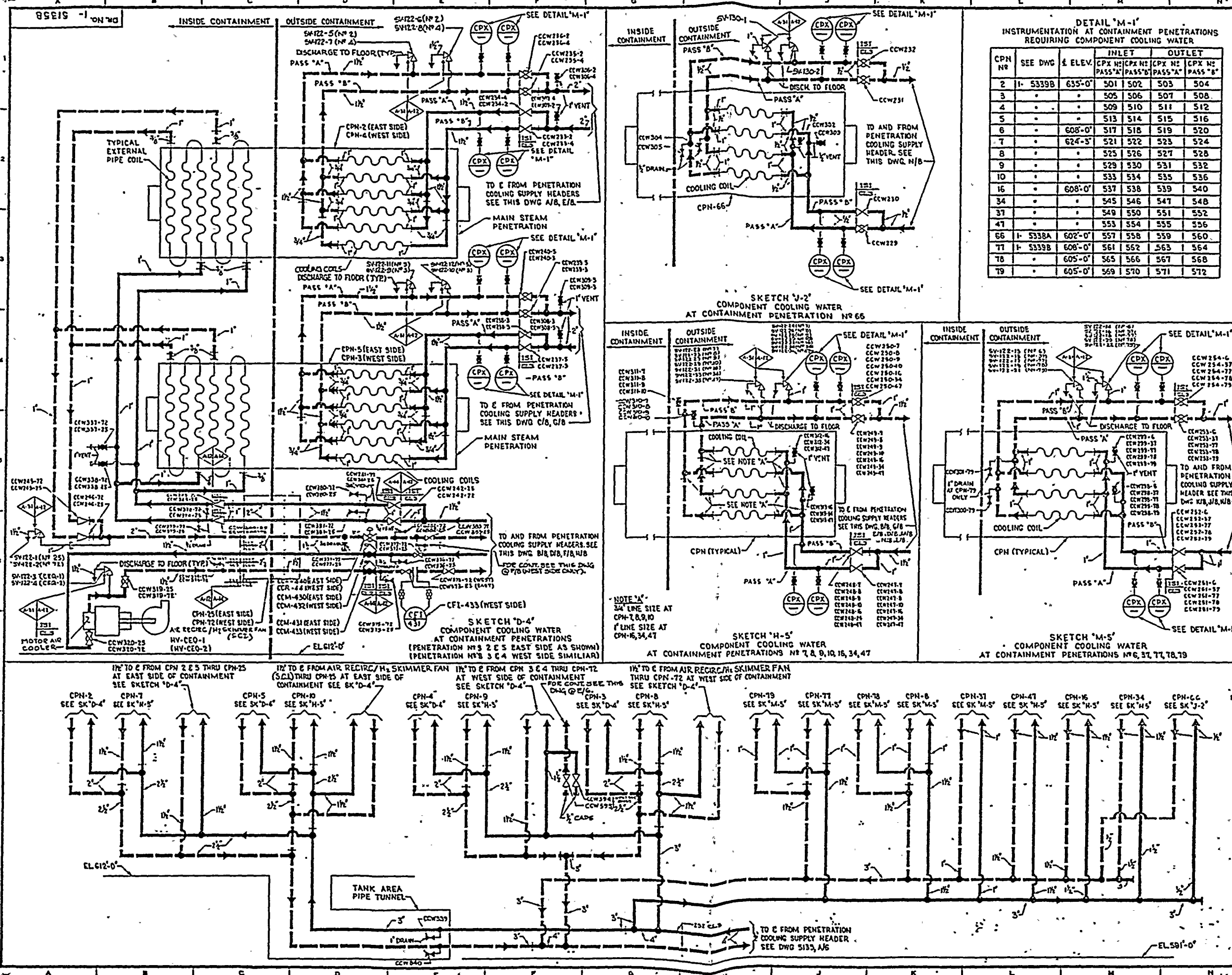

DETAIL 'M-1'
INSTRUMENTATION AT CONTAINMENT PENETRATIONS REQUIRING COMPONENT COOLING WATER

CPN NO	SEE DWG & ELEV.	INLET		OUTLET	
		CPX NO / PASS 'A'	CPX NO / PASS 'B'	CPX NO / PASS 'A'	CPX NO / PASS 'B'
2	I-5339B 635'-0"	501	502	503	504
3	"	505	506	507	508
4	"	509	510	511	512
5	"	513	514	515	516
6	"	517	518	519	520
7	"	521	522	523	524
8	"	525	526	527	528
9	"	529	530	531	532
10	"	533	534	535	536
16	"	537	538	539	540
34	"	545	546	547	548
37	"	549	550	551	552
47	"	553	554	555	556
66	I-5338A 602'-0"	557	558	559	560
77	I-5339B 608'-0"	561	562	563	564
78	"	565	566	567	568
79	"	569	570	571	572

GENERAL NOTES

LEGEND

- COMPONENT COOLING SUPPLY
- COMPONENT COOLING RETURN
- AUXILIARY PIPING

FOR VALVE, INSTRUMENT SAMPLING PIPE MATERIAL AND OTHER SYMBOLS NOT EXPLAINED ON THIS DWG., AND FOR MARK NUMBER CODES, SEE DWGS. 12-5103 & 12-5104. PENETRATION COOLING COILS ARE SEISMIC CLASS I

NOTE:

- FROM CODE CLASS 2 & 3 VENTS, THE 150 PSI BOUNDARY PRESSURE IS TO BE MAINTAINED AT ALL TIMES.
- FROM CODE CLASS 2 & 3 VENTS, THE 150 PSI BOUNDARY PRESSURE IS TO BE MAINTAINED AT ALL TIMES. THE VENTS SHALL BE NORMALLY CLOSED VALVES.
- ALL SV102 & SV103 TO BE AT 150 PSI UNLESS OTHERWISE NOTED.

THE UNIT PREFIX DESIGNATION FOR EACH COMPONENT IDENTIFICATION NUMBER IS '1' UNLESS OTHERWISE NOTED.

NOTE:
THIS DWG MADE UNIQUE FOR UNIT '1' AND SUPERSEDES DWG. 1-2-5135B REV. 7

HAND OPERATED VALVE IDENTIFICATION NUMBERS

- ONLY 'UNIQUE VALVE NUMBERS' APPEAR ON THIS DRAWING. SEE SEPARATE VALVE IDENTIFICATION LIST FOR EQUIVALENT DESIGN (MCR) NUMBERS.
- 'TAG' NUMBERS MODIFIED FOR DRAWING USE AS FOLLOWS:
TAG NO: 2-NSW-1000-W
APPEARS AS: NSW1000-W
- INSTRUMENT ROOT VALVE MARK 'R'S NOT SHOWN ON DRAWING (SEE VALVE IDENTIFICATION LIST) DERIVED BY ADDING TO INSTRUMENT NUMBER:
FOR SINGLE IMPULSE (V) FOR DOUBLE IMPULSE (V) (STREAM) V2 (CONSTR)

MF FOR MICROFILM STATUS SEE REVISION RECORD FOR 2123 DWG.

3-27-97 14 14 14 14

DATE NO. APPROVED

FOR REVISION DESCRIPTION SEE SEPARATE REVISION RECORD FOR THIS DRAWING

"THIS DRAWING IS THE PROPERTY OF THE AMERICAN ELECTRIC POWER SERVICE CORP. AND IS LOANED TO YOU FOR YOUR USE ONLY. IT IS NOT TO BE REPRODUCED OR COPIED IN ANY MANNER OR FOR ANY PURPOSE WITHOUT THE WRITTEN CONSENT OF THE AEP SERVICE CORP. ALL THE LATEST REVISIONS, INCLUDING THIS REVISION, ARE TO BE MAINTAINED ON THIS DRAWING."

INDIANA & MICHIGAN ELECTRIC CO.
DONALD C. COOK
NUCLEAR PLANT

DESIGNER: [Signature] CHECKER: [Signature]

FLOW DIAGRAM COMPONENT COOLING UNIT NO. 1 - SHEET 3 OF 3

DWG. NO. 1-5135B-14

AMERICAN ELECTRIC POWER SERVICE CORP.
2 BROADWAY NEW YORK

SI APERTURE CARD

Also Available On Aperture Card

FOR REVIEW ONLY NOT A CONTROLLED COPY

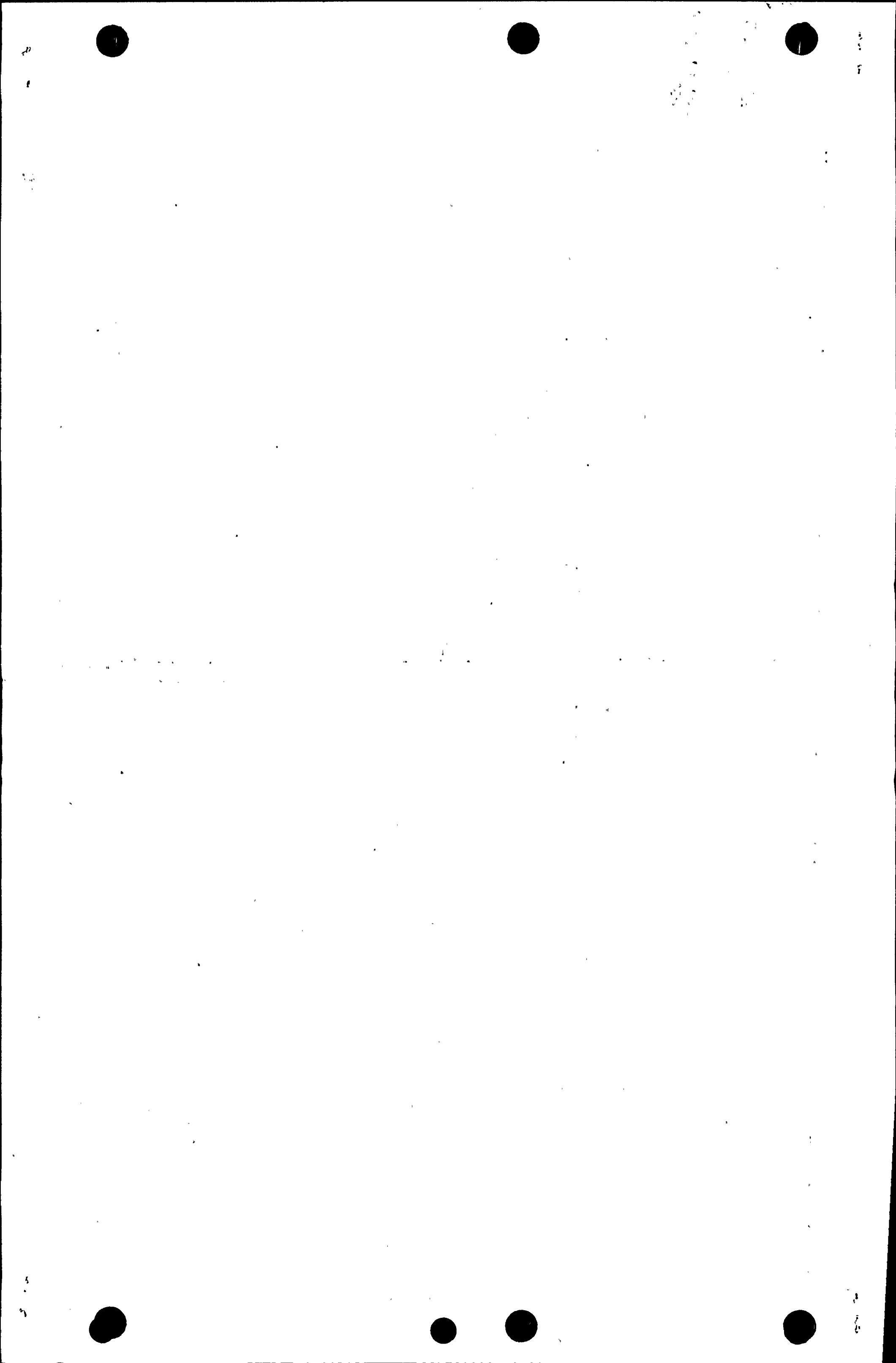

**"NOT FOR D.C. COOK
OPERATIONAL USE"**

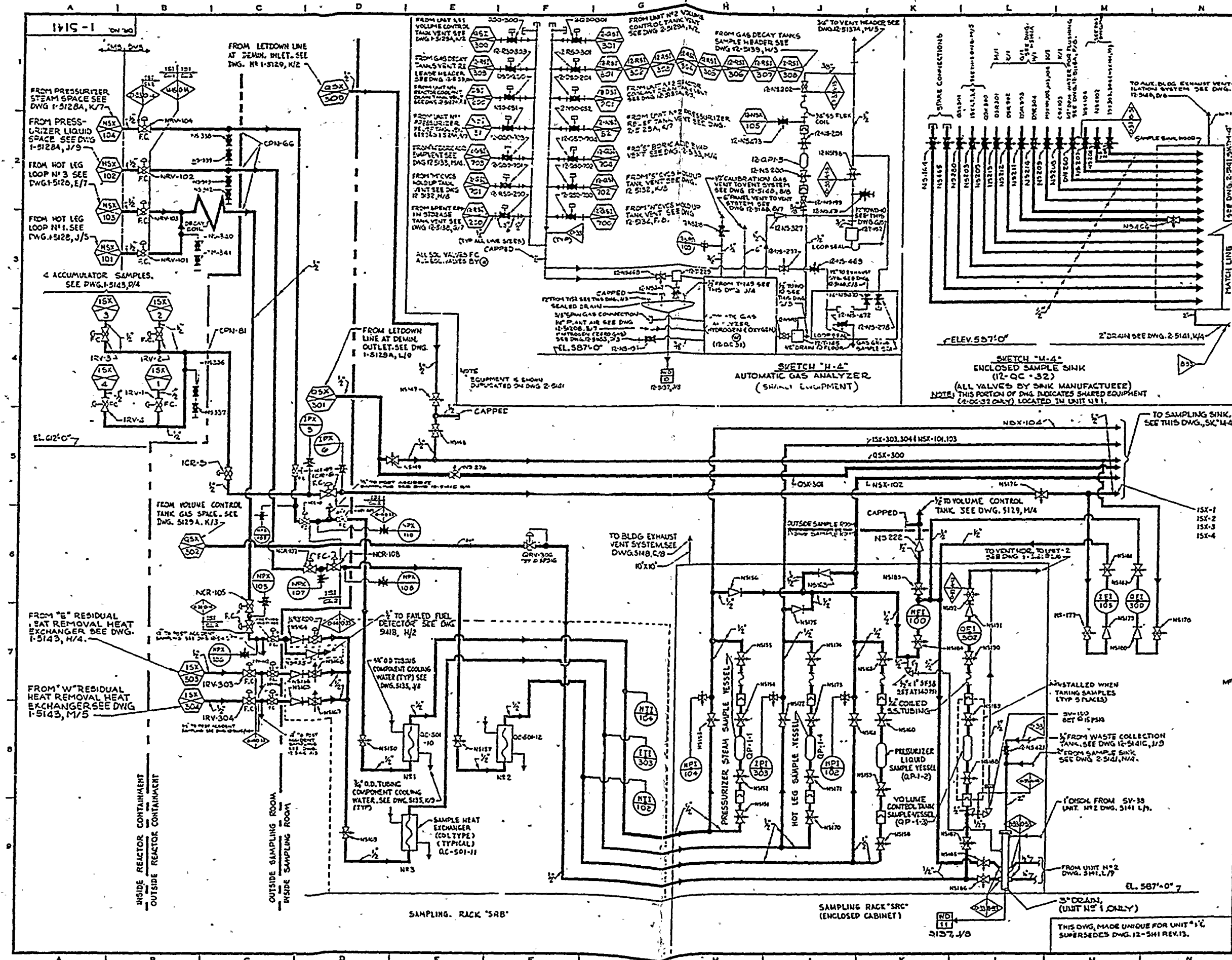

GENERAL NOTES

LEGEND

— MAIN FLOW
- - - AUX FLOW

FOR VALVE, INSTRUMENT, SAMPLING, PIPE MATERIAL, AND OTHER SYMBOLS NOT EXPLAINED ON THIS DWG., AND FOR MARK NUMBER CODES, SEE DWGS. 12-5103 & 12-5104.

SYMBOLS

□ QUICK DISCONNECT COUPLING

⊙ BY WESTINGHOUSE

ALL PIPING TO BE EXCEPT AS NOTED

ALL EQUIPMENT S.C. II

⊕ VALVE SHOWN ON DWG. 12-5104

TYPE CLASS NOTES

1. FOR CODE CLASS B, THE 181 BOUNDARY INCLUDES THE FIRST FOOT ABOVE THE FIRST FOOT VALVE.

2. FOR CODE CLASS 2, VALVE & DRUMS, THE 181 BOUNDARY EXTENDS UP TO & INCLUDES THE FIRST FOOT OF THE PIPE, EXCEPT FOR COUPLERS.

THE UNIT PREFIX DESIGNATION FOR EACH COMPONENT IDENTIFICATION NUMBER IS "1" UNLESS OTHERWISE NOTED.

SWITCH "M-4" AUTOMATIC GAS ANALYZER (SHOWN EQUIPMENT)

SWITCH "M-4" ENCLOSED SAMPLE SINK (12-OC-32)

(ALL VALVES BY SINK MANUFACTURER)

NOTE: THIS PORTION OF DWG. INDICATES SHARED EQUIPMENT (12-OC-32 ONLY) LOCATED IN UNIT 1U1.

HAND OPERATED VALVE IDENTIFICATION NUMBERS

1. ONLY "UNIQUE VALVE NUMBERS" APPEAR ON THIS DRAWING. SEE SEPARATE VALVE IDENTIFICATION LIST FOR EQUIVALENT DESIGN (MCR) NUMBERS.

2. "TAG" NUMBERS MODIFIED FOR DRAWING USE AS FOLLOWS:
TAG NO.: 2-NSW-1005-W
APPEARS AS: NSW1005

3. INSTRUMENT ROOT VALVE MARK "R" IS NOT SHOWN ON DRAWING (SEE VALVE IDENTIFICATION LIST) DERIVED BY ADDING TO INSTRUMENT NUMBER:
FOR SINGLE SAMPLE VESSEL FOR DOUBLE IMPULSE, VMPSTREAM V200MSTRM

FOR MICROFILM STATUS SEE
M. REVISION RECORD FOR THIS DWG.

DATE	NO.	APPROVED
2-13-57	29	Don Cook

FOR REVISION DESCRIPTION SEE SEPARATE REVISION RECORD FOR THIS DRAWING

INDIANA & MICHIGAN ELECTRIC CO.
DONALD C. COOK
NUCLEAR PLANT

BRIDGMAN MICHIGAN

**FLOW DIAGRAM
NUCLEAR SAMPLING
UNIT NO. 1
SHEET 1 OF 3**

DR. NO. 1-5141-29

DESIGNED	DATE	BY
12/1/56	12/1/56	Don Cook
CHECKED	DATE	BY
12/1/56	12/1/56	Don Cook
APPROVED	DATE	BY
12/1/56	12/1/56	Don Cook

AMERICAN ELECTRIC POWER SERVICE CORP.
2 BROADWAY NEW YORK

Also Available
Aperture Car

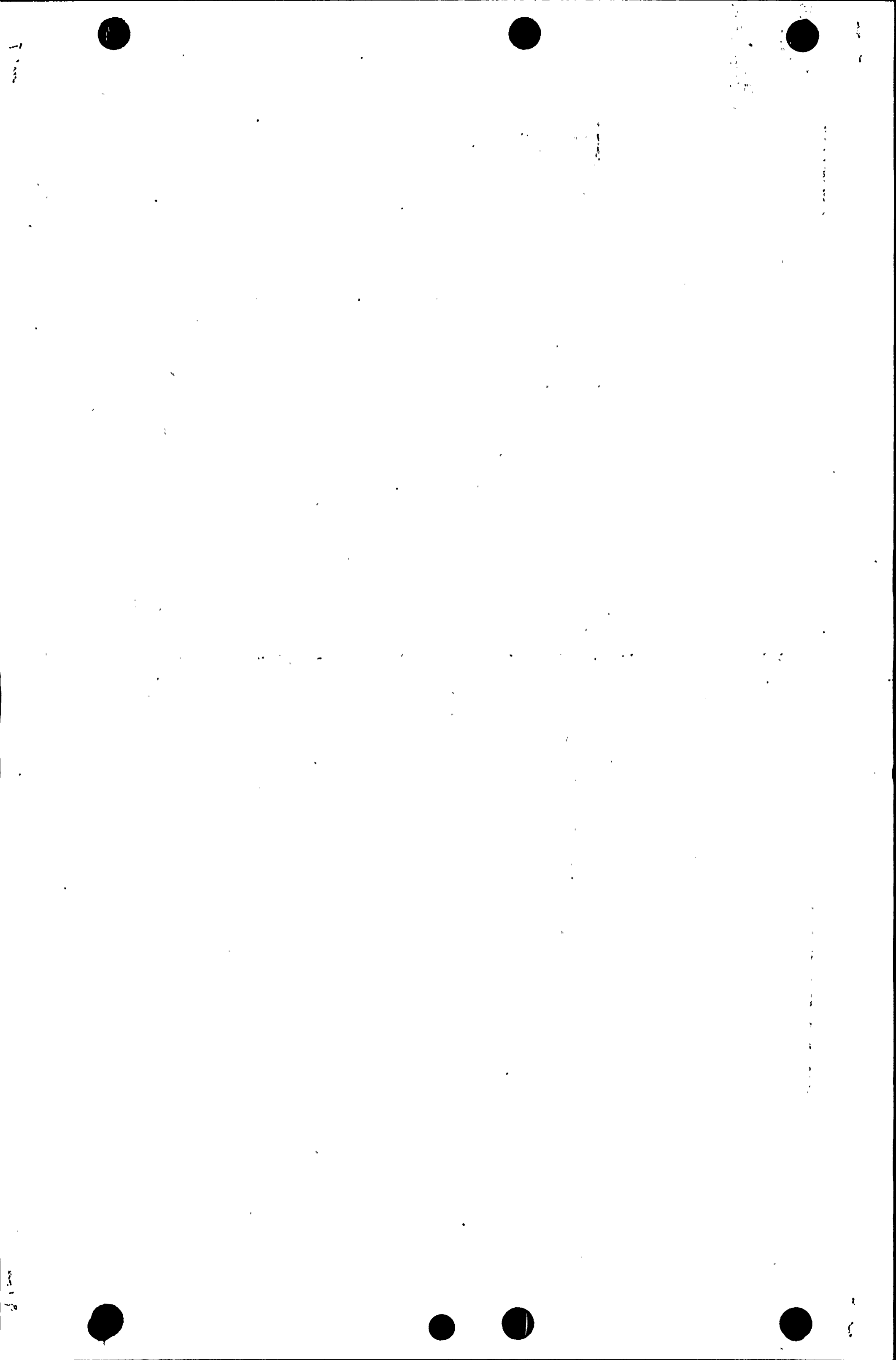

NOT FOR D.C. COOK
OPERATIONAL USE

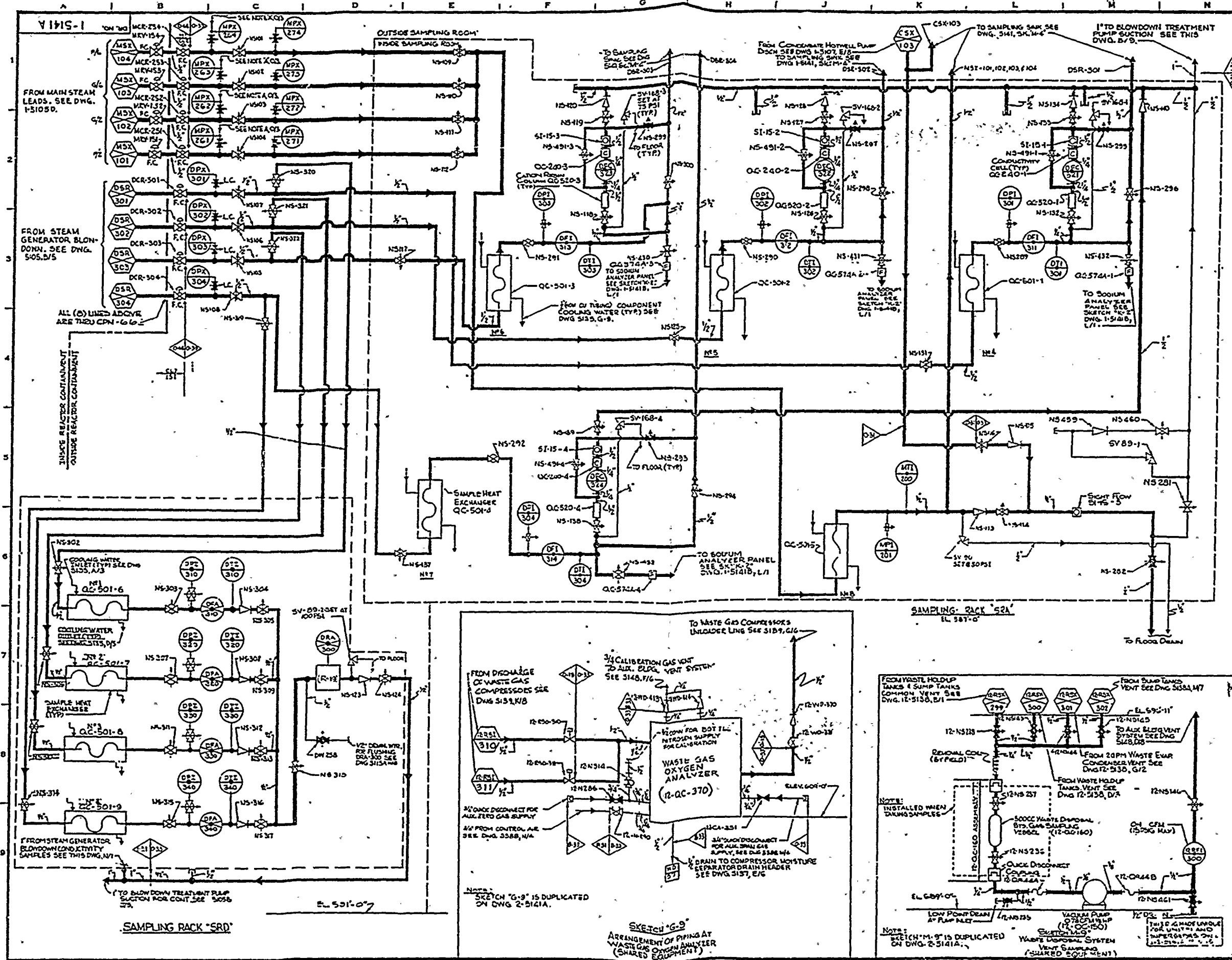

GENERAL NOTES

LEGEND
 — MAIN FLOW
 - - - - - AUX. FLOW

FOR VALVE, INSTRUMENT SAMPLING, PIPE MATERIAL AND OTHER SYMBOLS NOT EXPLAINED ON THIS DWG., AND FOR MARK NUMBER CODES SEE DWG'S 12-5103 & 5104.
 ALL PIPING TO BE EXCEPT AS NOTED
 ALL EQUIPMENT S.C. III

NOTE 'A' C.I. CO. 1/2" NAL SUPPLY FOR DRAINING STEAM GENERATORS FOR CONTAMINATION SEE DWG. 5185 & 5187

NOTE 'B' THIS SYMBOL DESIGNATES A FILTER

THE UNIT PREFIX DESIGNATION FOR EACH COMPONENT IDENTIFICATION NUMBER IS '1' UNLESS OTHERWISE NOTED.

HAND OPERATED VALVE IDENTIFICATION NUMBERS
 1. ONLY 'UNIQUE VALVE NUMBERS' APPEAR ON THIS DRAWING. SEE SEPARATE VALVE IDENTIFICATION LIST FOR EQUIVALENT DESIGN (MCR) NUMBERS
 2. 'TAG' NUMBERS MODIFIED FOR DRAWING USE AS FOLLOWS:
 TAG #1: 2-N33-V03-W APPEARS AS: N33V03
 3. INSTRUMENT ROOT VALVE MARK N'S NOT SHOWN ON DRAWING (SEE VALVE IDENTIFICATION LIST) DERIVED BY ADDING TO INSTRUMENT NUMBER: FOR SINGLE IMPULSE (V) FOR DOUBLE IMPULSE (V) FOR STREAM (V) FOR DOWNSTREAM (V)

3-5-87	32	REV A15
DATE	NO.	APPROVED

FOR REVISION DESCRIPTION SEE SEPARATE REVISION RECORD FOR THIS DRAWING

THIS DRAWING IS THE PROPERTY OF THE AMERICAN ELECTRIC POWER SERVICE CORP. AND IS LOANED TO YOU WITHOUT TITLE. IT IS NOT TO BE REPRODUCED OR TRANSMITTED IN ANY FORM OR BY ANY MEANS, ELECTRONIC OR MECHANICAL, INCLUDING PHOTOCOPYING, RECORDING, OR BY ANY INFORMATION STORAGE AND RETRIEVAL SYSTEM, WITHOUT THE WRITTEN PERMISSION OF THE A.E.P. SERVICE CORP. IN THE EVENT OF ANY DISCREPANCY BETWEEN THIS DRAWING AND ANY OTHER DOCUMENT, THIS DRAWING SHALL PREVAIL.

INDIANA & MICHIGAN ELECTRIC CO.
 DONALD C. COOK
 NUCLEAR PLANT

BRIDGEWATER MICHIGAN
**FLOW DIAGRAM
 NUCLEAR SAMPLING
 UNIT NO. 1
 SHEET 2 OF 3**

DWG. NO.	1-5141A-32
DATE	3/5/87
BY	[Signature]
CHECKED	[Signature]
APPROVED	[Signature]
SCALE	AS SHOWN
PROJECT	NUCLEAR SAMPLING UNIT NO. 1
SHEET	2 OF 3

Also Available On Aperture Card

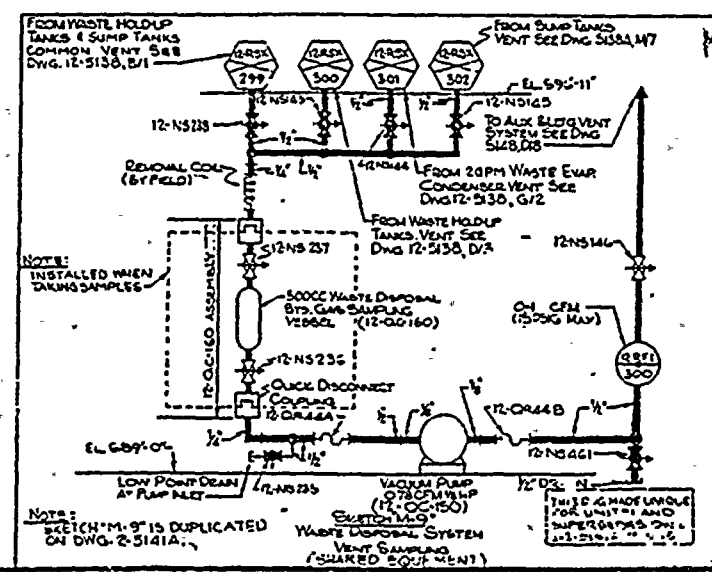
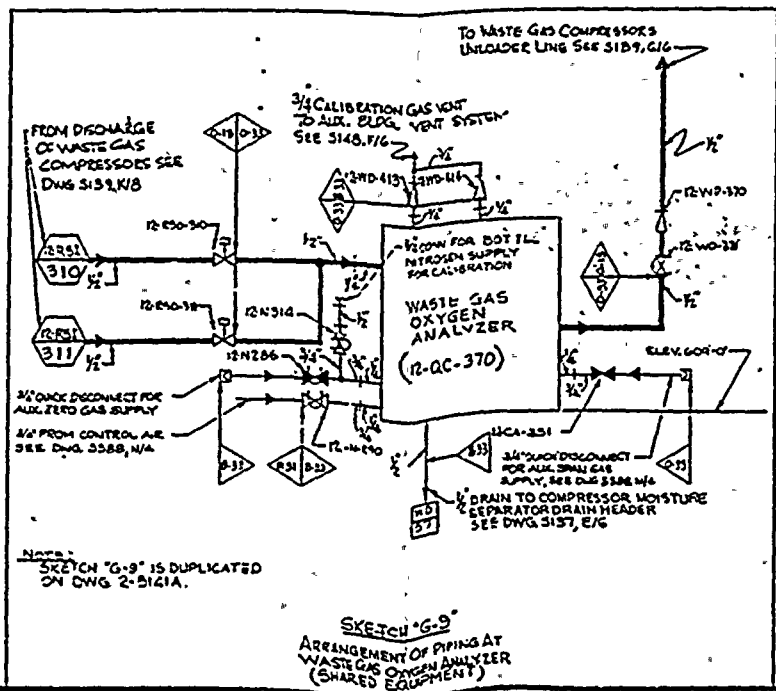

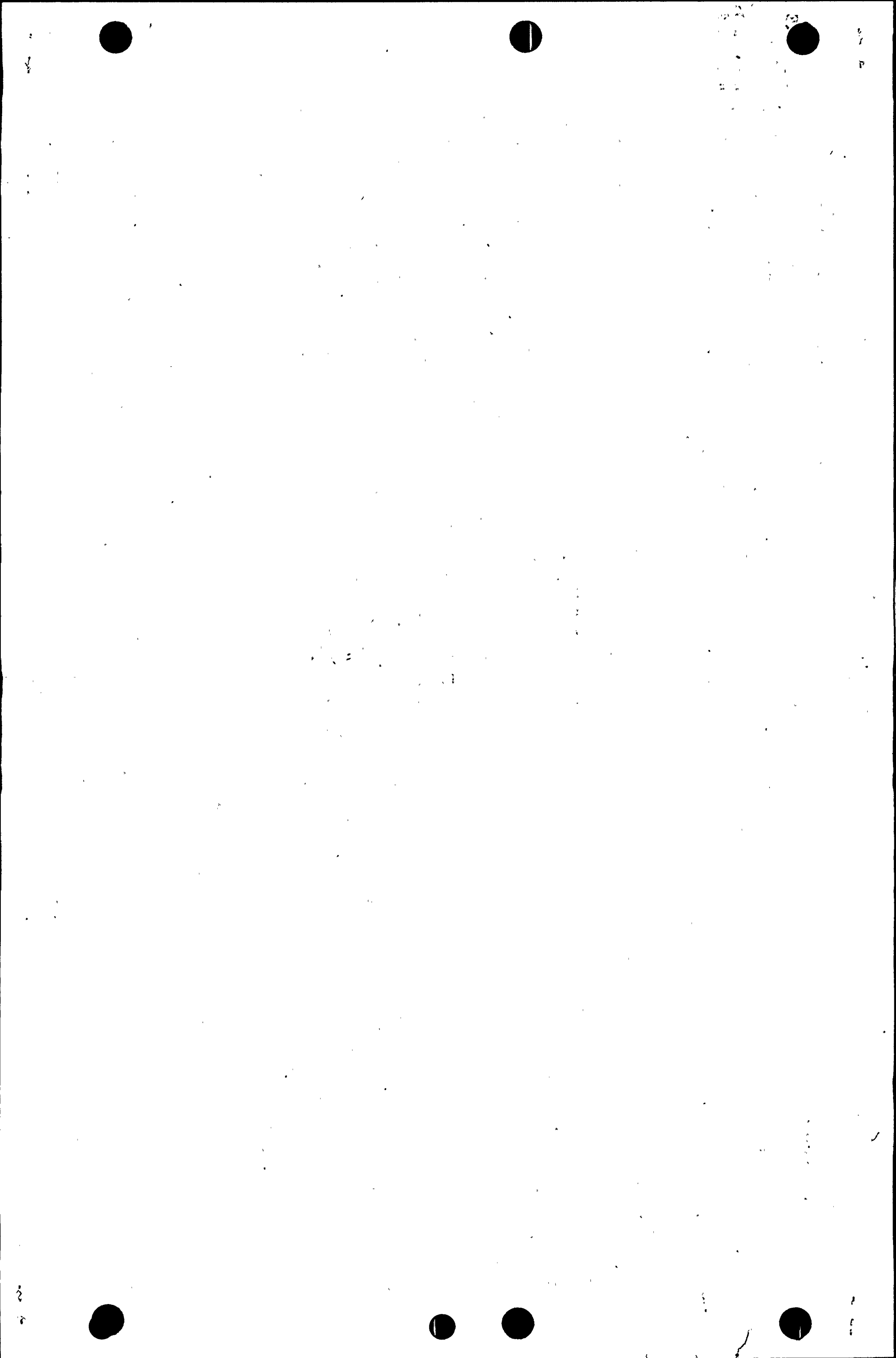

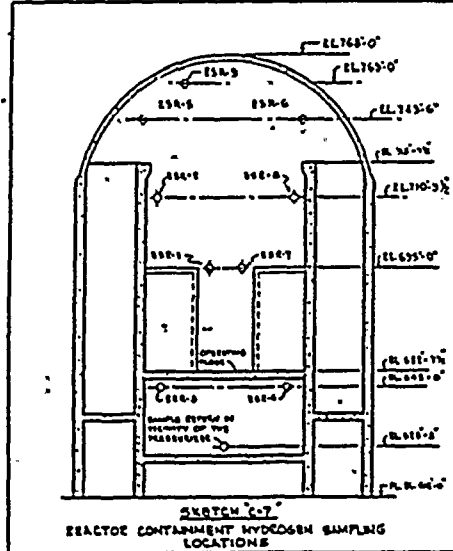
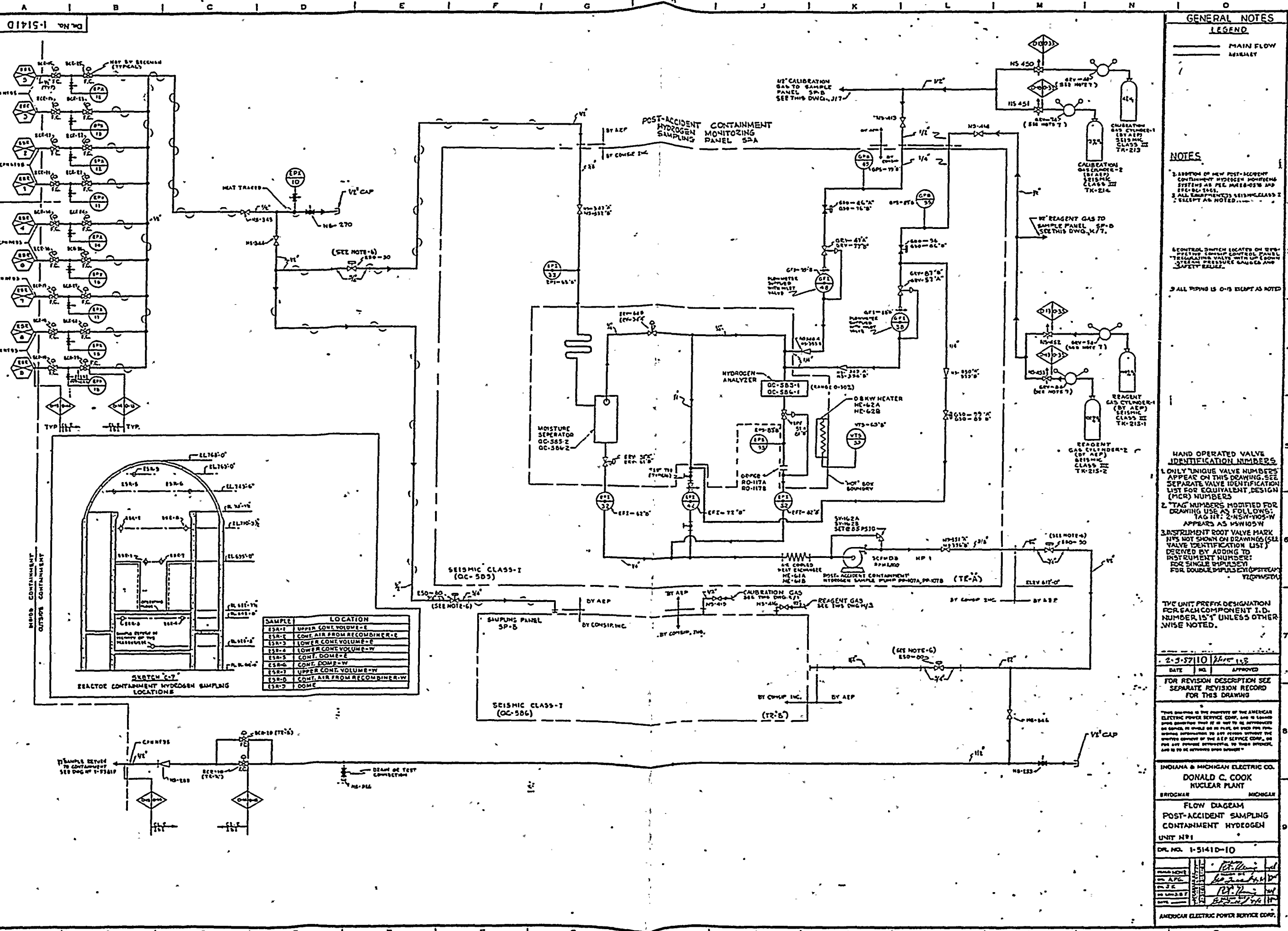

SAMPLE	LOCATION
ES-1	UPPER CONT. VOLUME-E
ES-2	CONT. AIR FROM RECOMBINER-E
ES-3	LOWER CONT. VOLUME-E
ES-4	LOWER CONT. VOLUME-W
ES-5	CONT. DOME-E
ES-6	CONT. DOME-W
ES-7	UPPER CONT. VOLUME-W
ES-8	CONT. AIR FROM RECOMBINER-W
ES-9	DOME

GENERAL NOTES

LEGEND

— MAIN FLOW
--- MANUALLY

NOTES

1. LOCATION OF NEW POST-ACCIDENT CONTAINMENT HYDROGEN MONITORING SYSTEMS AS PER NUREG-0576 AND EPC-R-2001.

2. ALL INSTRUMENTS SEISMIC CLASS II EXCEPT AS NOTED.

3. CONTROL SWITCH LOCATED ON REACTOR CONTAINMENT CONTROL PANEL REGULATING VALVE WITH UP-E DOWN SYSTEM PRESSURE GAUGES AND SAFETY RELIEF.

4. ALL PIPING IS O-15 EXCEPT AS NOTED.

HAND OPERATED VALVE IDENTIFICATION NUMBERS

1. ONLY UNIQUE VALVE NUMBERS APPEAR ON THIS DRAWING. SEE SEPARATE VALVE IDENTIFICATION LIST FOR EQUIVALENT DESIGN (MCR) NUMBERS.

2. TAG NUMBERS MODIFIED FOR DRAWING USE AS FOLLOWS:
TAG 111: 2-MSH-1105-W APPEARS AS 111W105-W

3. INSTRUMENT ROOT VALVE MARKETS NOT SHOWN ON DRAWINGS (SEE VALVE IDENTIFICATION LIST) DERIVED BY ADDING TO INSTRUMENT NUMBER:
FOR SINGLE PULSE: (P) STREAM
FOR DOUBLE PULSE: (D) STREAM

THE UNIT PREFIX DESIGNATION FOR EACH COMPONENT I.D. NUMBER IS "1" UNLESS OTHERWISE NOTED.

2-5-57110 Rev. 1-58

DATE NO. APPROVED

FOR REVISION DESCRIPTION SEE SEPARATE REVISION RECORD FOR THIS DRAWING

THIS DRAWING IS THE PROPERTY OF THE AMERICAN ELECTRIC POWER SERVICE CORP. AND IS LOANED TO YOU ON THE CONDITION THAT IT IS NOT TO BE REPRODUCED OR COPIED IN WHOLE OR IN PART, OR USED FOR ANY OTHER PURPOSE WITHOUT THE WRITTEN CONSENT OF THE AEP SERVICE CORP. NO PART OF THIS DRAWING IS TO BE REPRODUCED OR COPIED IN ANY MANNER WITHOUT THE WRITTEN CONSENT OF THE AEP SERVICE CORP.

INDIANA & MICHIGAN ELECTRIC CO.
DONALD C. COOK
NUCLEAR PLANT

BROOKMAN MICHIGAN

FLOW DIAGRAM
POST-ACCIDENT SAMPLING
CONTAINMENT HYDROGEN
UNIT NO. 1

DR. NO. 1-5141-D-10

AMERICAN ELECTRIC POWER SERVICE CORP.

SI APERTURE CARD

Also Available On Aperture Card

FOR REVIEW COPY

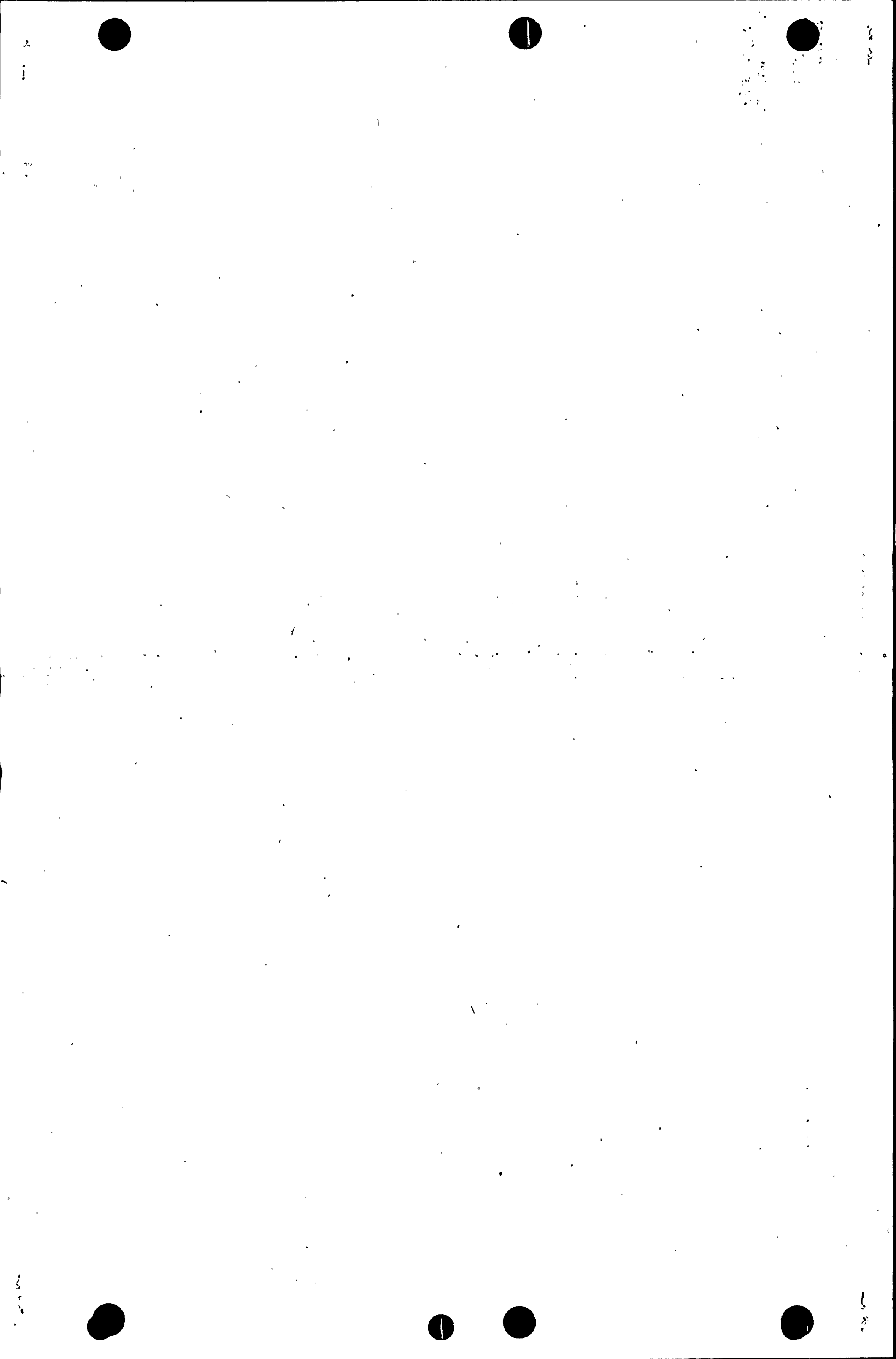

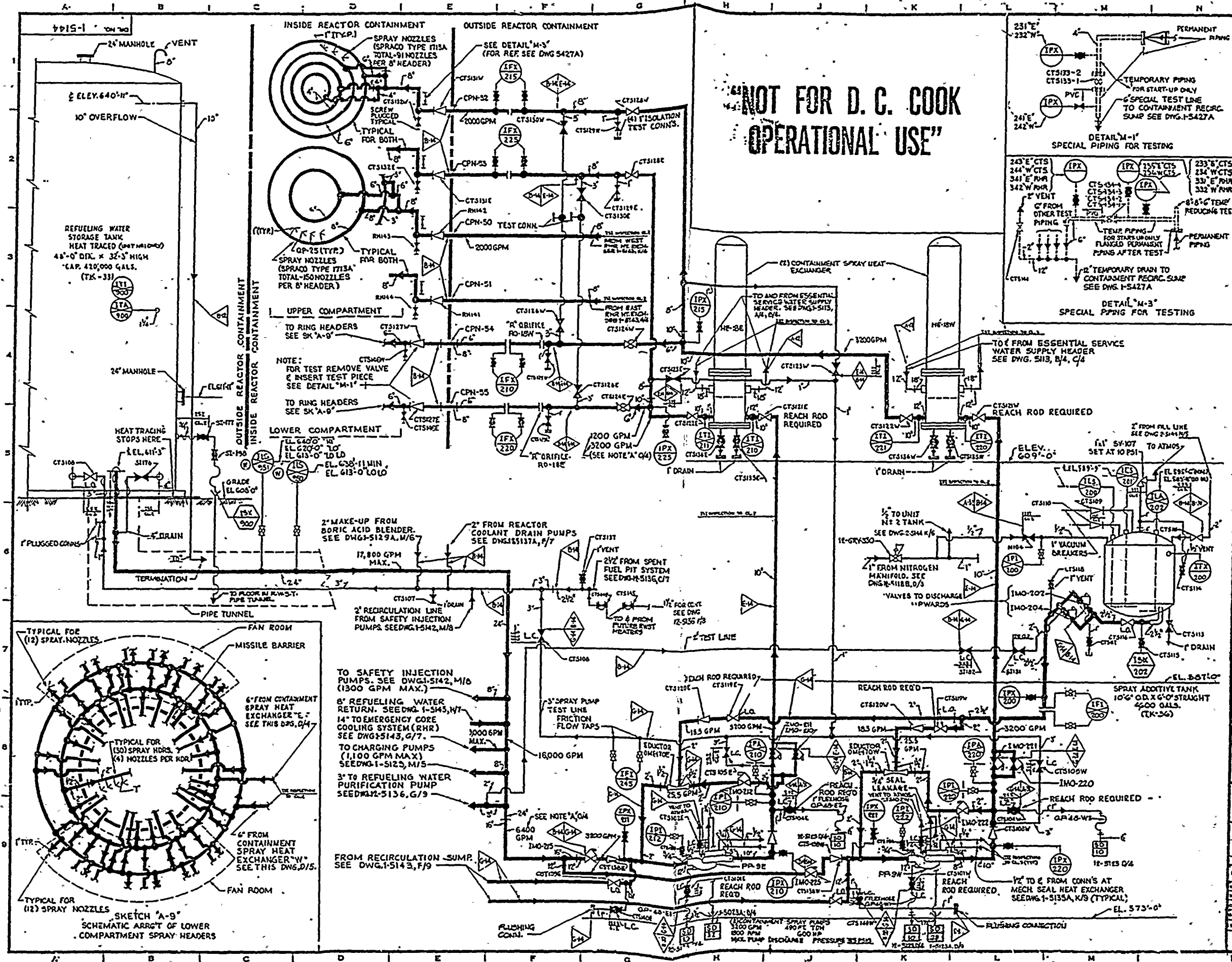

SI
APERTURE
CARD

Also Available On
Aperture Card

GENERAL NOTES																				
LEGEND																				
<p>FOR VALVE, INSTRUMENT, SAMPLING, PIPING MATERIAL AND OTHER SYMBOLS NOT EXPLAINED ON THIS DWG., AND FOR MARK NUMBER CODES, SEE DWG. 12-503 AND 12-504.</p> <p>ALL EQUIPMENT IS SEISMIC CLASS I EXCEPT AS NOTED</p> <p>BY WESTINGHOUSE</p> <p>DRAINS FROM SPRAY ADDITIVE TANKS TO SPRAY ADDITIVE TANK SUMP 12-517, H/9</p> <p>NOTE: A) G/S, P/9, FLOWS SHOWN ARE REDUCED BY 25.5 GPM WHEN A/CN & B/FACTORS ARE IN SERVICE.</p> <p>NOTE: B) REFER TO DWG. 12-512 FOR PORTIONS OF PIPING CONTAINED WITHIN LEAK DETECTION ENCLOSURES.</p> <p>THE UNIT PREFIX DESIGNATION FOR EACH COMPONENT IDENTIFICATION NUMBER IS "U" UNLESS OTHERWISE NOTED.</p> <p>FROM COOL CLASS 1 & 2 INSTRUMENT COMP. THE INSTRUMENT COMP. TO BE INCLUDED IN THE UNIT PREFIX VALUE.</p> <p>FROM COOL CLASS 1 & 2 INSTRUMENT COMP. THE INSTRUMENT COMP. TO BE INCLUDED IN THE INSTRUMENT IDENTIFICATION NUMBER.</p> <p>INSTRUMENTS SHOWN ON THIS DWG. ARE TO BE NORMALLY CLOSED VALVES ON SYSTEMS IN WHICH THE INSTRUMENT IS TO BE NORMALLY CLOSED VALVE.</p> <p>FROM COOL CLASS 1 & 2 INSTRUMENT COMP. THE INSTRUMENT COMP. TO BE INCLUDED IN THE INSTRUMENT IDENTIFICATION NUMBER.</p>																				
NOTE: THIS DWG. MADE UNIQUE FOR UNIT 1 AND SUPERSEDES DWG. 12-514 REV. 18.																				
<p>NAME OPERATED VALVE IDENTIFICATION NUMBERS</p> <p>1. ONLY "TRIGGLE" VALVE NUMBERS APPEAR ON THIS DRAWING. SEE SEPARATE VALVE IDENTIFICATION LIST FOR EQUIVALENT DESIGN (MCR) NUMBERS.</p> <p>2. TAG NUMBERS MODIFIED FOR DRAWING USE AS FOLLOWS: TAG NO. 2-NM-VIO-W APPEARS AS; 2-NM-VIO-W</p> <p>3. INSTRUMENT ROOT VALVE MARKING IS NOT SHOWN ON DRAWING (SEE VALVE IDENTIFICATION LIST) DERIVED BY ADDING TO INSTRUMENT NUMBER: FOR SINGLE INSTRUMENT FOR DOUBLE INSTRUMENT VALVE STREAM FOR DOUBLE INSTRUMENT VALVE STREAM FOR DOUBLE INSTRUMENT VALVE STREAM</p>																				
FOR INSTRUMENT STATUS SEE DWG. 12-514 REV. 18																				
1-27-77	28	REV. 18																		
DATE	NO.	APPROVED																		
FOR REVISION DESCRIPTION SEE SEPARATE REVISION RECORD FOR THIS DRAWING																				
THIS DRAWING IS THE PROPERTY OF INDIANAPOLIS ELECTRIC POWER SERVICE CO., AND IS LOANED TO YOU FOR YOUR USE ONLY. IT IS NOT TO BE REPRODUCED OR COPIED IN ANY MANNER WITHOUT THE WRITTEN PERMISSION OF THE AEP SERVICE CO., AND THE COMPANY ASSUMES NO LIABILITY FOR THE ACCURACY OF THE INFORMATION CONTAINED HEREIN.																				
INDIANA & MICHIGAN ELECTRIC CO. DONALD C. COOK NUCLEAR PLANT																				
FLOW DIAGRAM CONTAINMENT SPRAY UNIT - NR 1																				
OR. NO. 1-514-28																				
<table border="1"> <tr> <td>DESIGNED BY</td> <td>DATE</td> <td>APPROVED</td> </tr> <tr> <td>D. C. COOK</td> <td>1-27-77</td> <td>[Signature]</td> </tr> <tr> <td>CHECKED BY</td> <td>DATE</td> <td>APPROVED</td> </tr> <tr> <td>[Signature]</td> <td></td> <td>[Signature]</td> </tr> <tr> <td>IN CHARGE</td> <td>DATE</td> <td>APPROVED</td> </tr> <tr> <td>[Signature]</td> <td></td> <td>[Signature]</td> </tr> </table>			DESIGNED BY	DATE	APPROVED	D. C. COOK	1-27-77	[Signature]	CHECKED BY	DATE	APPROVED	[Signature]		[Signature]	IN CHARGE	DATE	APPROVED	[Signature]		[Signature]
DESIGNED BY	DATE	APPROVED																		
D. C. COOK	1-27-77	[Signature]																		
CHECKED BY	DATE	APPROVED																		
[Signature]		[Signature]																		
IN CHARGE	DATE	APPROVED																		
[Signature]		[Signature]																		

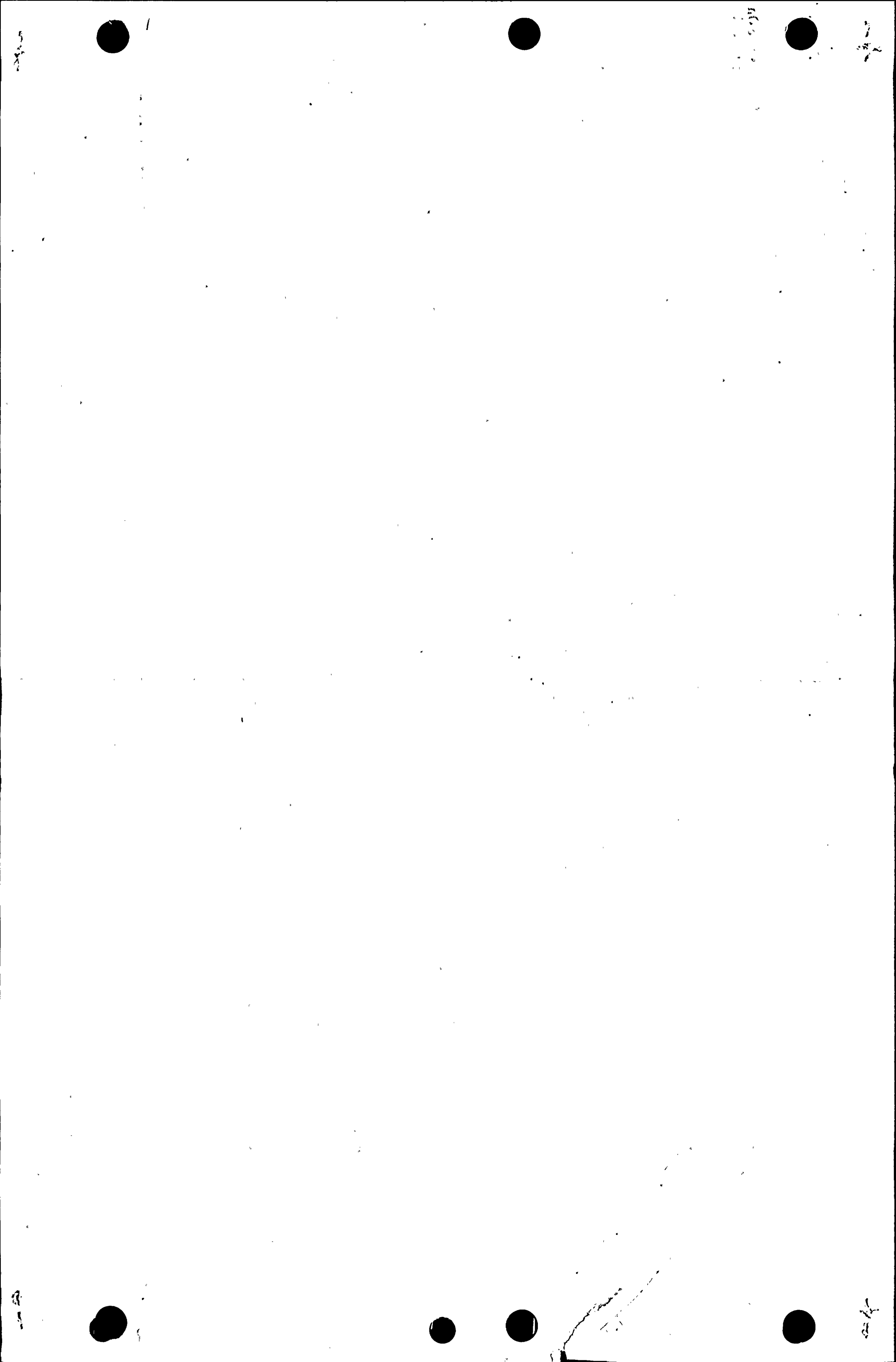

SI
APERTURE
CARD

Also Available On
Aperture Card

**"NOT FOR D. C. COOK
OPERATIONAL USE"**

GENERAL NOTES

LEGEND
— MAIN FLOW
--- AUXILIARY FLOW

FOR VALVE, INSTRUMENT, SAMPLING PIPING, MATERIAL AND OTHER SYMBOLS NOT EXPLAINED ON THIS DWG. AND FOR MARK NUMBER CODES SEE DWG 5128, 5130-5134.

NOTE A
2" VALVE MARK #15
AS NOTED

NOTE B
ALL EQUIPMENT, VALVES (INSTRUMENTS SUPPLIED BY VESTINGHOUSE EXCEPT AS NOTED)

NOTE C
VALVE MARK #15
TAG # (N1)
IRV-10 (N1)
IRV-12 (N2)
IRV-14 (N3)
IRV-16 (N4)

NOTE D
VALVE MARK #15
TAG # (N1)
IRV-10 (N1)
IRV-12 (N2)
IRV-14 (N3)
IRV-16 (N4)

NOTE E
FOR COOL CLASS 1 & 2 INSTRUMENT CONNECTIONS, THE 1" BOUNDARY EXTENDS TO AND INCLUDES THE FIRST ROOF VALVE.

NOTE F
FOR COOL CLASS 1 VALVES AND DRAINS, THE 1" BOUNDARY EXTENDS TO AND INCLUDES THE SECOND BOUNDARY CLOSED VALVE OR EXTENDS TO AND INCLUDES THE DRAIN PLUG OR CAP AFTER A NORMALLY CLOSED VALVE.

NOTE G
FOR COOL CLASS 2 (S) VALVES AND DRAINS, THE 1" BOUNDARY EXTENDS TO AND INCLUDES THE FIRST NORMALLY CLOSED VALVE.

THE UNIT PREFIX DESIGNATION FOR EACH COMPONENT IDENTIFICATION NUMBER IS UNLESS OTHERWISE NOTED.

THIS DWG MADE UNCLASSIFIED AND SUPERSEDED DWG # 1-2-514-D REV. 22

HAND OPERATED VALVE IDENTIFICATION NUMBERS
ONLY "UNIQUE VALVE NUMBERS" APPEAR ON THIS DRAWING. SEE SEPARATE VALVE IDENTIFICATION LIST FOR EQUIVALENT DESIGN (MCA) NUMBERS.

2. "TAG" NUMBERS MODIFIED FOR DRAWING USE AS FOLLOWS:
TAG #1: 2-NUMBER APPEARS AS: N1N2N3

3. INSTRUMENT ROOT VALVE MARK #15 NOT SHOWN ON DRAWING (SEE VALVE IDENTIFICATION LIST) DERIVED BY ADDING TO INSTRUMENT NUMBER:
FOR SINGLE IMPULSE: V
FOR DOUBLE IMPULSE: V2

FOR MICROFILM STATUS SEE REVISION RECORD FOR THIS DWG.

DATE: 1-27-57
NO. 36
APPROVED: DONALD C. COOK

FOR REVISION DESCRIPTION SEE SEPARATE REVISION RECORD FOR THIS DRAWING.

INDIANA & MICHIGAN ELECTRIC CO.
DONALD C. COOK
NUCLEAR PLANT
FLOW DIAGRAM
EMERG. CORE COOLING UNIT NO. 1
DWG. NO. 1-5143-36

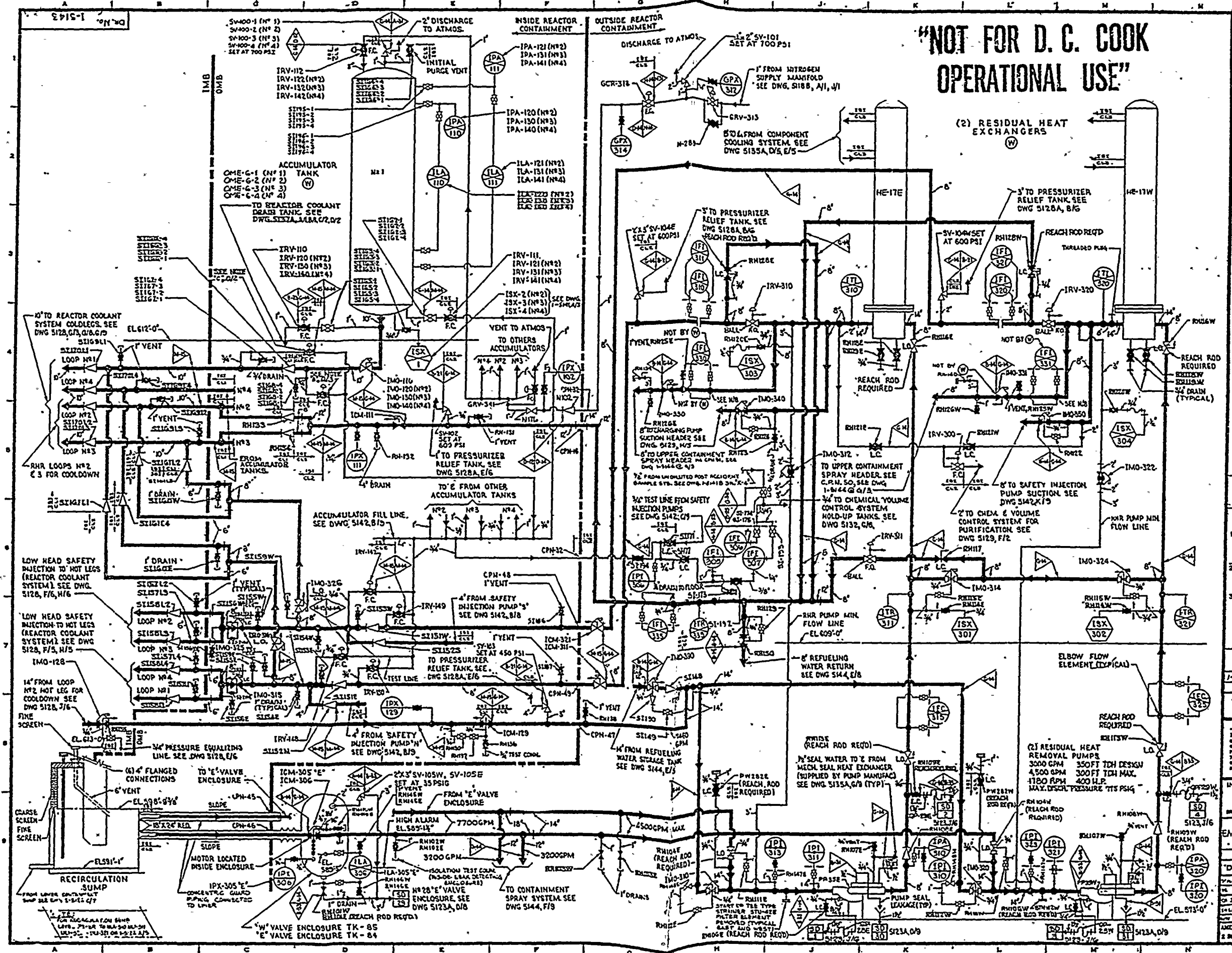

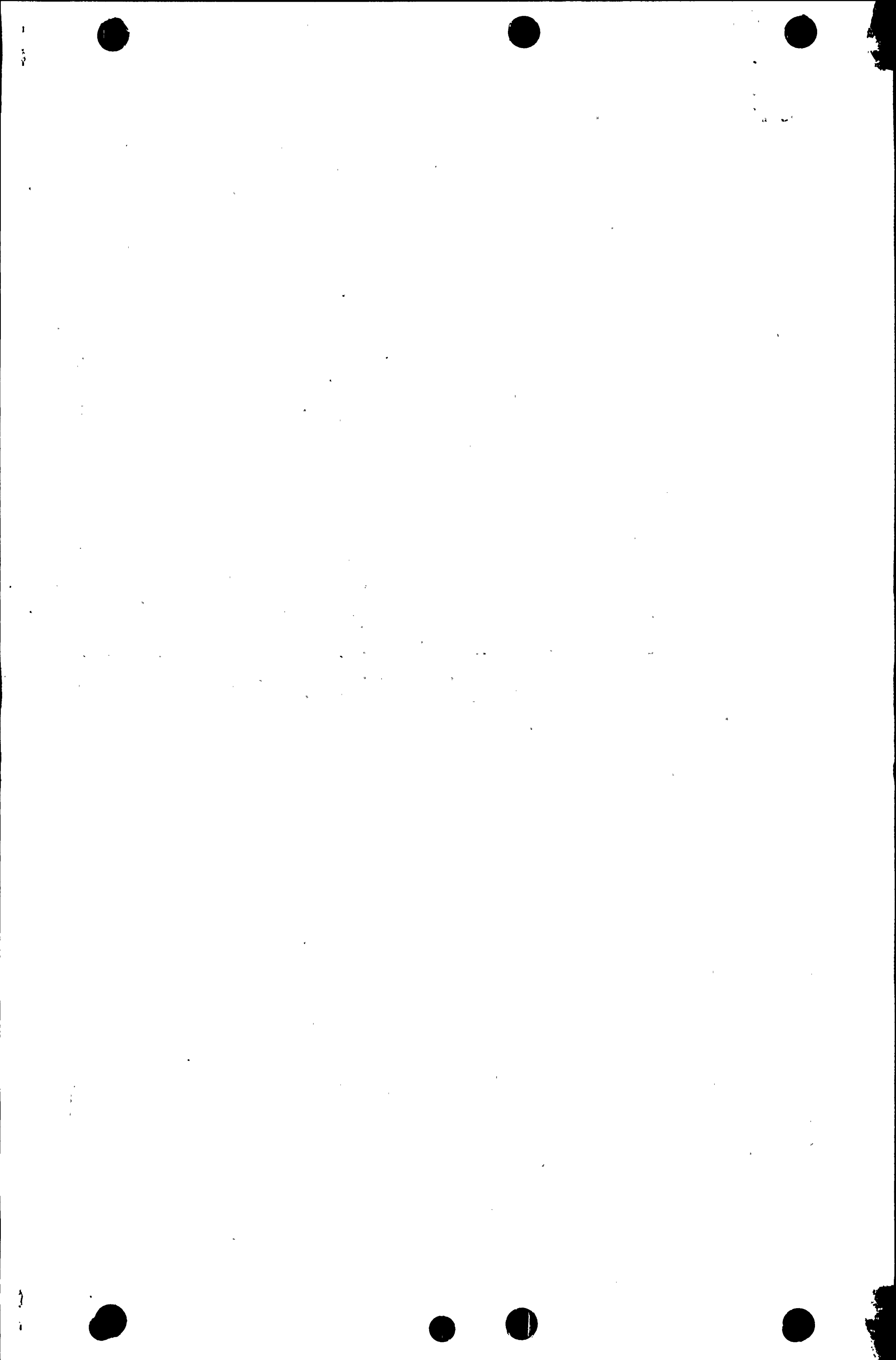

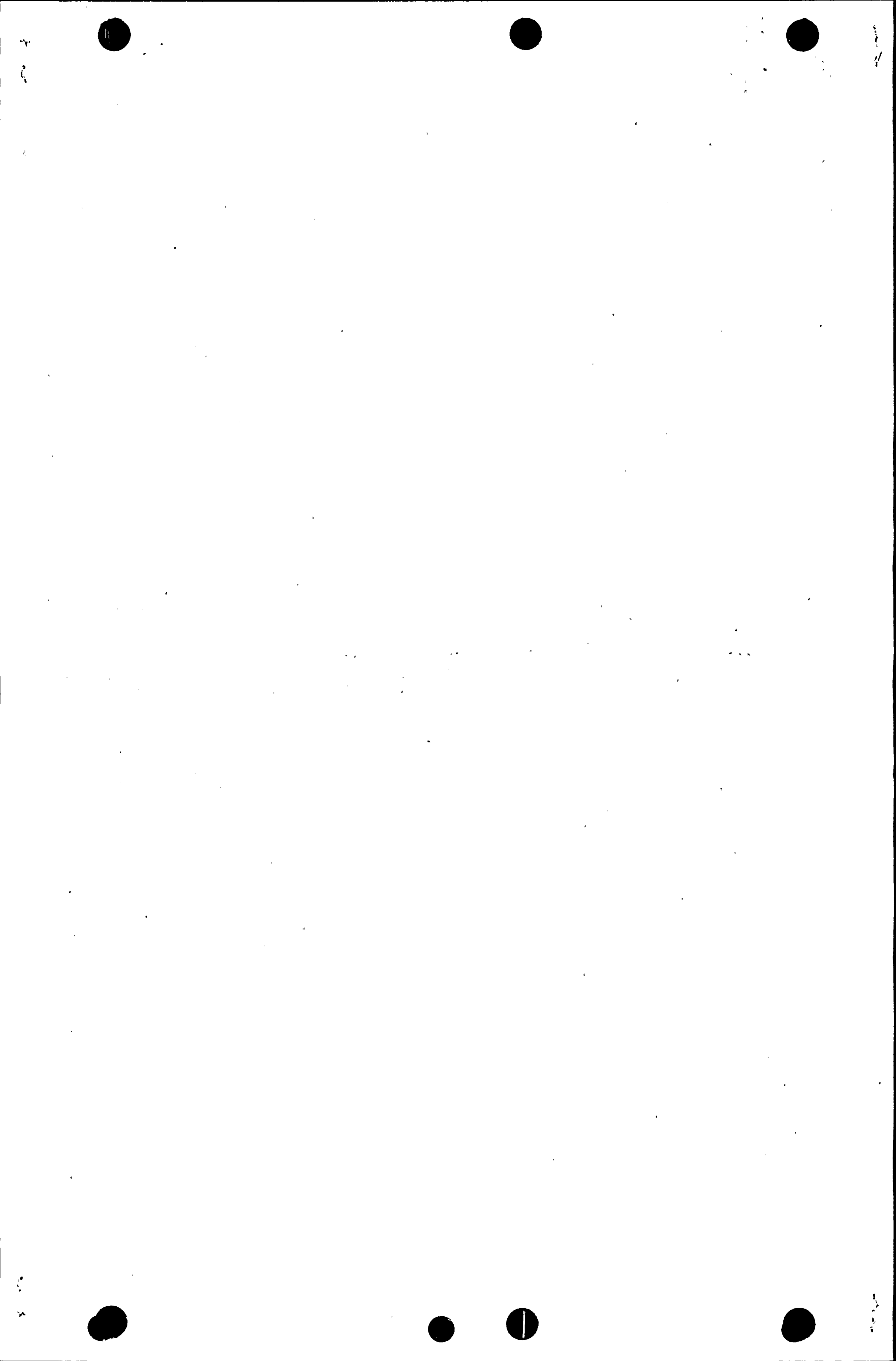

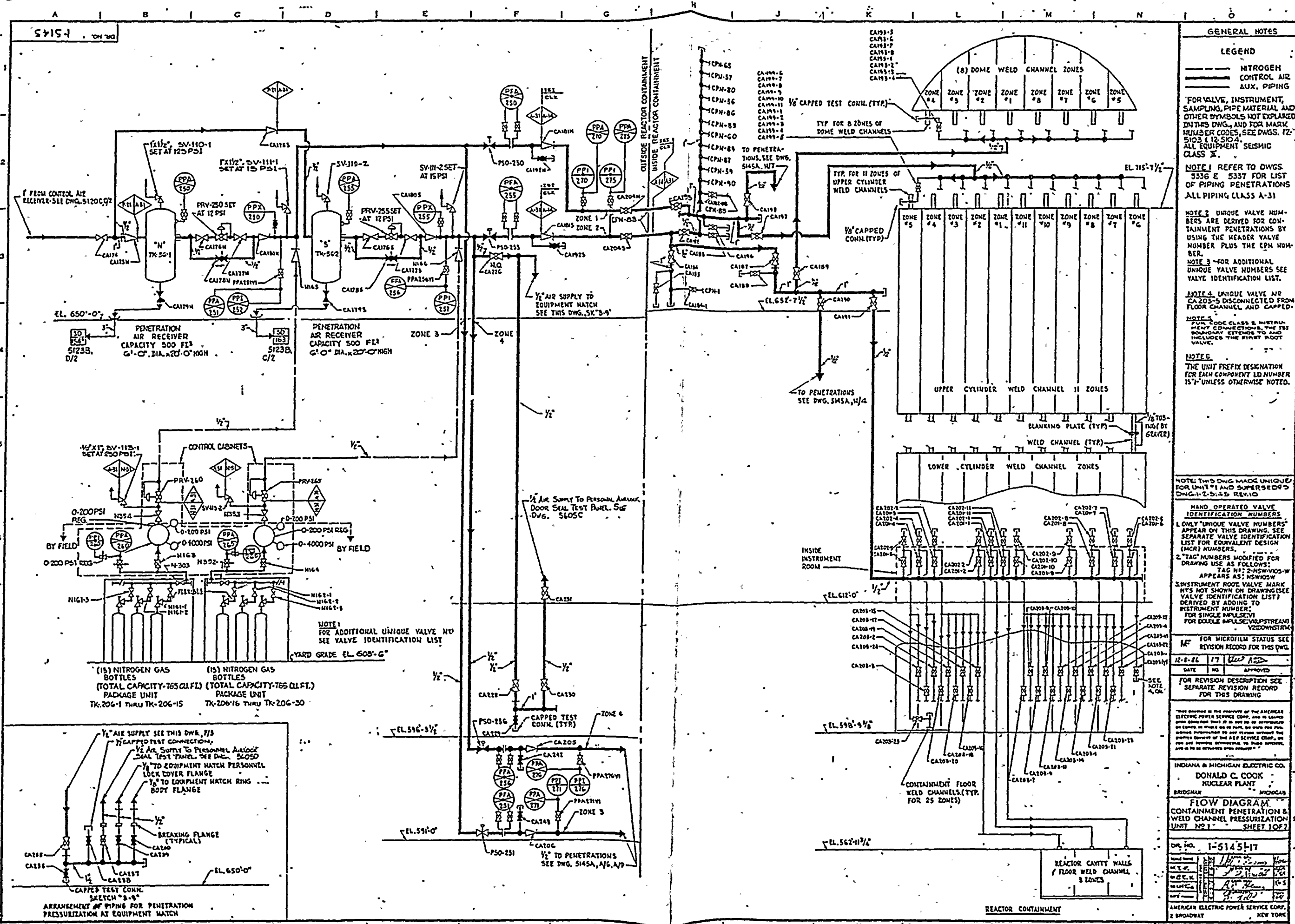

GENERAL NOTES

LEGEND
 --- NITROGEN
 --- CONTROL AIR
 --- AUX. PIPING

FOR VALVE, INSTRUMENT, SAMPLING, PIPE MATERIAL AND OTHER SYMBOLS NOT EXPLAINED ON THIS DWG., AND FOR MARK NUMBER CODES, SEE DWGS. 12-5103 & 12-5104. ALL EQUIPMENT SEISMIC CLASS II.

NOTE 1 REFER TO DWGS. 5336 & 5337 FOR LIST OF PIPING PENETRATIONS ALL PIPING CLASS A-31

NOTE 2 UNIQUE VALVE NUMBERS ARE DERIVED FOR CONTAINMENT PENETRATIONS BY USING THE HEADER VALVE NUMBER PLUS THE CPN NUMBER.

NOTE 3 FOR ADDITIONAL UNIQUE VALVE NUMBERS SEE VALVE IDENTIFICATION LIST.

NOTE 4 UNIQUE VALVE NO. CA205-5 DISCONNECTED FROM FLOOR CHANNEL AND CAPPED.

NOTE 5 FOR CLASS 2 INSTRUMENT CONNECTIONS, THE 3RD BOUNDARY EXTENDS TO AND INCLUDES THE FIRST ROOT VALVE.

NOTE 6 THE UNIT PREFIX DESIGNATION FOR EACH COMPONENT ID NUMBER IS "I" UNLESS OTHERWISE NOTED.

NOTE 7 THIS DWG. MADE UNIQUE FOR UNIT #1 AND SUPERSEDES DWG. 12-5145 REV. 10

HAND OPERATED VALVE IDENTIFICATION NUMBERS
 1. ONLY "UNIQUE VALVE NUMBERS" APPEAR ON THIS DRAWING. SEE SEPARATE VALVE IDENTIFICATION LIST FOR EQUIVALENT DESIGN (MCR) NUMBERS.

2. TAG NUMBERS MODIFIED FOR DRAWING USE AS FOLLOWS:
 TAG #1: 2-NSW-VIOS-W APPEARS AS: NSWVIOSW

3. INSTRUMENT ROOT VALVE MARK # IS NOT SHOWN ON DRAWING (SEE VALVE IDENTIFICATION LIST) DERIVED BY ADDING TO INSTRUMENT NUMBER:
 FOR SINGLE IMPULSE: V1/DOWNSTREAM
 FOR DOUBLE IMPULSE: V1/DOWNSTREAM

4. FOR MICROFILM STATUS SEE REVISION RECORD FOR THIS DWG.

DATE	NO.	APPROVED
12-8-81	17	[Signature]

FOR REVISION DESCRIPTION SEE SEPARATE REVISION RECORD FOR THIS DRAWING

INDIANA & MICHIGAN ELECTRIC CO.
 DONALD C. COOK
 NUCLEAR PLANT

BRIDGMAN MODUCAN

FLOW DIAGRAM
 CONTAINMENT PENETRATION & WELD CHANNEL PRESSURIZATION
 UNIT #2-1 SHEET 10F7

DWG. NO. 1-5145-17

REVISION	DATE	BY	CHKD.
1	12-8-81	[Signature]	[Signature]
2	12-8-81	[Signature]	[Signature]
3	12-8-81	[Signature]	[Signature]
4	12-8-81	[Signature]	[Signature]

SI APERTURE CARD
 Also Available On Aperture Card

FOR CONTAINMENT ONLY
 NOT A CONTROLLED COPY

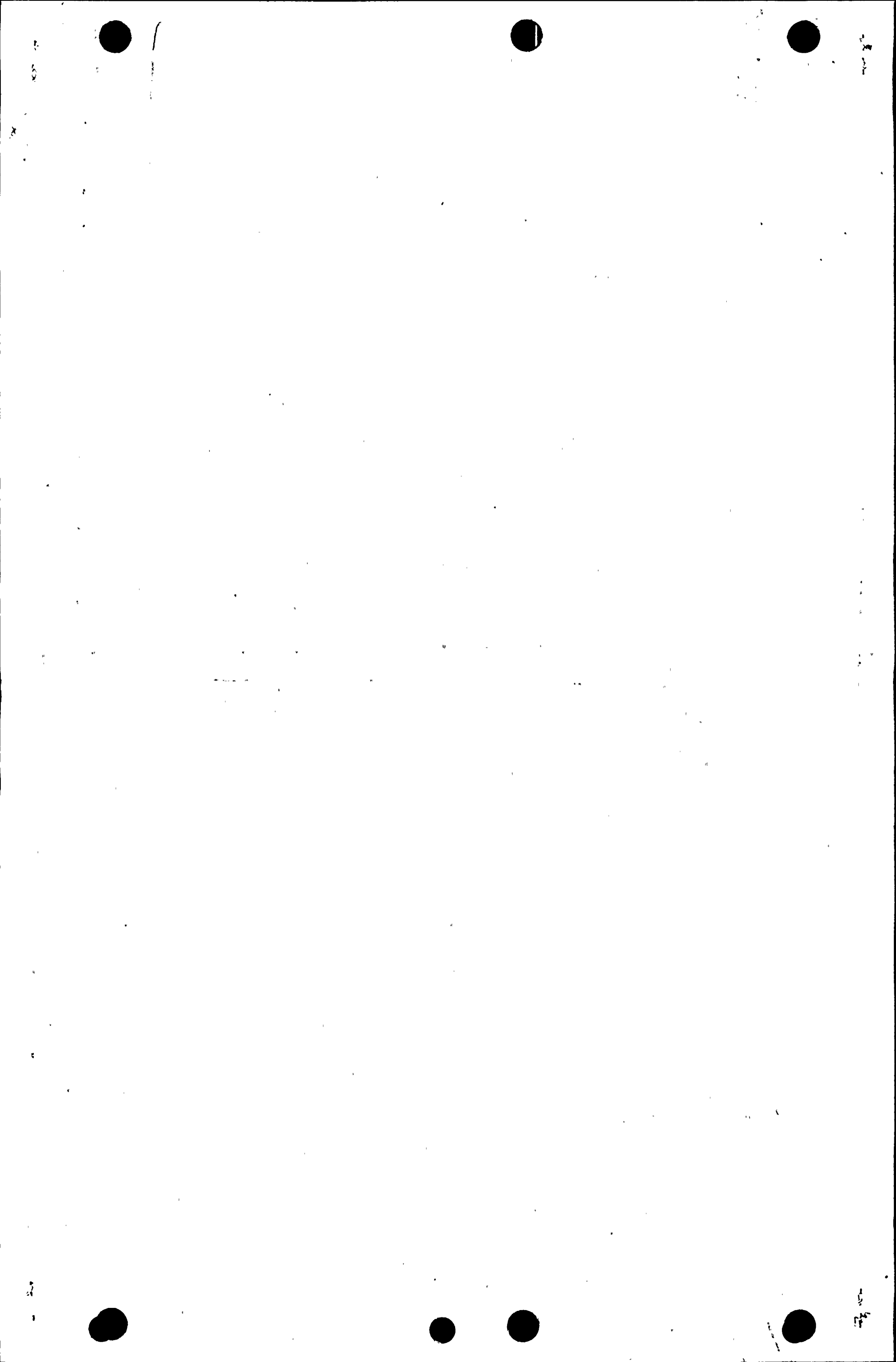

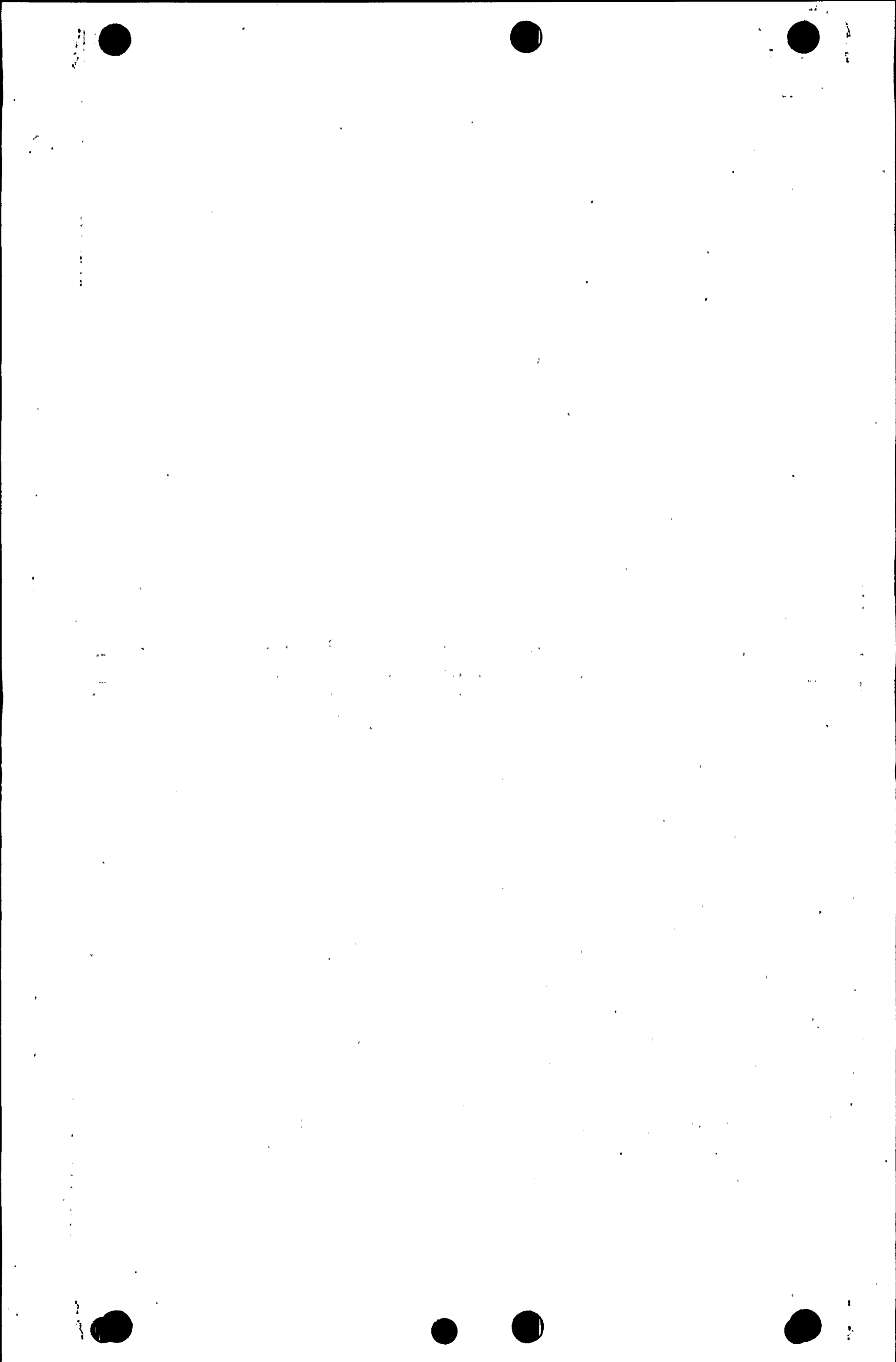

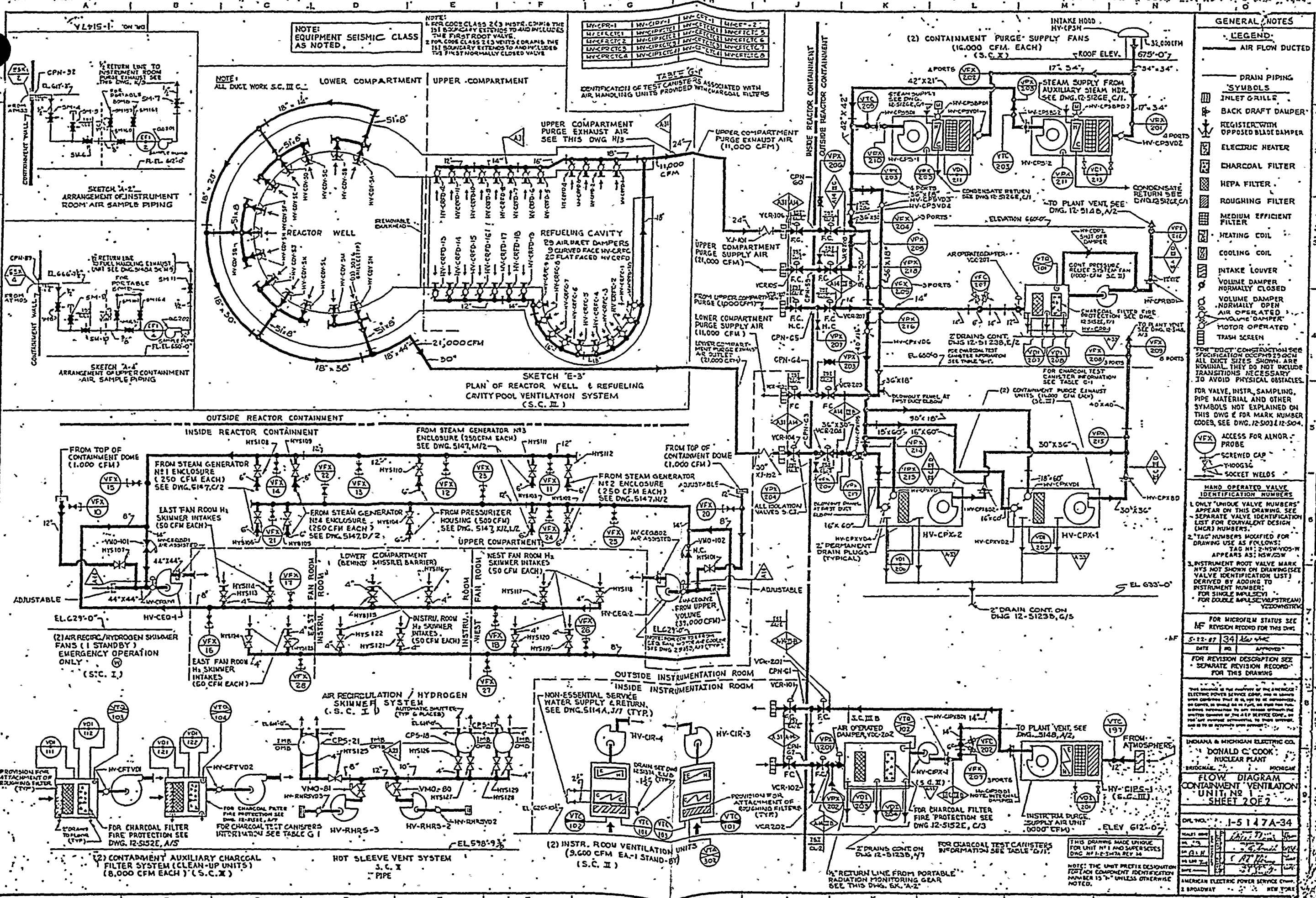

NOTE: EQUIPMENT SEISMIC CLASS AS NOTED.

NOTE: 1. FOR CODE CLASS 2(3) INSTR. COMP. THE 1ST BOUNDARY EXTENDS TO AND INCLUDES THE FIRST ROOT VALVE.
2. FOR CODE CLASS 2(3) VENTS & DRAINS THE 1ST BOUNDARY EXTENDS TO AND INCLUDES THE FIRST NORMALLY CLOSED VALVE.

TABLE G-1
IDENTIFICATION OF TEST CANISTERS ASSOCIATED WITH AIR HANDLING UNITS PROVIDED WITH CHARCOAL FILTERS

HY-CR-1	HY-CR-1	HY-CR-1	HY-CR-2
HY-CR-2	HY-CR-2	HY-CR-2	HY-CR-3
HY-CR-3	HY-CR-3	HY-CR-3	HY-CR-4
HY-CR-4	HY-CR-4	HY-CR-4	HY-CR-5
HY-CR-5	HY-CR-5	HY-CR-5	HY-CR-6
HY-CR-6	HY-CR-6	HY-CR-6	HY-CR-7
HY-CR-7	HY-CR-7	HY-CR-7	HY-CR-8

GENERAL NOTES

- LEGEND:
- AIR FLOW DUCTED
 - DRAIN PIPING
 - ⊠ INLET GRILLE
 - ⊞ BACK DRAFT DAMPER
 - ⊞ REGISTER WITH OPPOSED BLADE DAMPER
 - ⊞ ELECTRIC HEATER
 - ⊞ CHARCOAL FILTER
 - ⊞ HEPA FILTER
 - ⊞ ROUGHING FILTER
 - ⊞ MEDIUM EFFICIENT FILTER
 - ⊞ HEATING COIL
 - ⊞ COOLING COIL
 - ⊞ INTAKE LOUVER
 - ⊞ VOLUME DAMPER NORMALLY CLOSED
 - ⊞ VOLUME DAMPER NORMALLY OPEN
 - ⊞ AIR OPERATED VOLUME DAMPER
 - ⊞ MOTOR OPERATED TRASH SCREEN
- FOR "DOCT" CONSTRUCTION SEE SPECIFICATION 00CPM-2500. ALL DUCT SIZES SHOWN ARE NOMINAL. THEY DO NOT INCLUDE TRANSMISSIONS NECESSARY TO AVOID PHYSICAL OBSTACLES.
- FOR VALVE, INSTR., SAMPLING PIPE MATERIAL AND OTHER SYMBOLS NOT EXPLAINED ON THIS DWG. FOR MARK NUMBER CODES SEE DWG. 12-503 & 12-504.
- ACCESS FOR ALOR-PROBE
- SCREWED CAP
- Y-100G36
- SOCKET WELDS

- HAND OPERATED VALVE IDENTIFICATION NUMBERS
- ONLY "UNIQUE VALVE NUMBERS" APPEAR ON THIS DRAWING. SEE SEPARATE VALVE IDENTIFICATION LIST FOR EQUIVALENT DESIGN (MCR) NUMBERS.
 - "TAG" NUMBERS MODIFIED FOR DRAWING USE AS FOLLOWS:
APPEARS AS: 2-HSV-200-W
 - INSTRUMENT ROOT VALVE MARK "HVS" NOT SHOWN ON DRAWING (SEE VALVE IDENTIFICATION LIST) DERIVED BY ADDING TO INSTRUMENT NUMBER:
FOR SINGLE INLET/OUTLET: VCR-101
FOR DOUBLE INLET/OUTLET: VCR-101/2

FOR MICROFILM STATUS SEE REVISION RECORD FOR THIS DWG.

5-12-67	34	REVISED
DATE	NO.	APPROVED

FOR REVISION DESCRIPTION SEE SEPARATE REVISION RECORD FOR THIS DRAWING.

INDIANA & MICHIGAN ELECTRIC CO.
DONALD C. COOK
NUCLEAR PLANT

FLOW DIAGRAM
CONTAINMENT VENTILATION
UNIT NO. 2
SHEET 2 OF 2

DWG. NO.: 1-5147A-34

THIS DRAWING MADE UNIQUE FOR UNIT NO. 2 AND SUPERSEDES DWG. NO. 1-5147A-REV. 1A

NOTE: THE UNIT PREFIX DESIGNATION FOR AN COMPONENT IDENTIFICATION NUMBER IS "U" UNLESS OTHERWISE NOTED.

AMERICAN ELECTRIC POWER SERVICE CO.,
2 BROADWAY, NEW YORK

SI
APERTURE
CARD

Also Available On
Aperture Card

FOR REVISION ONLY
A CONTROLLED COPY

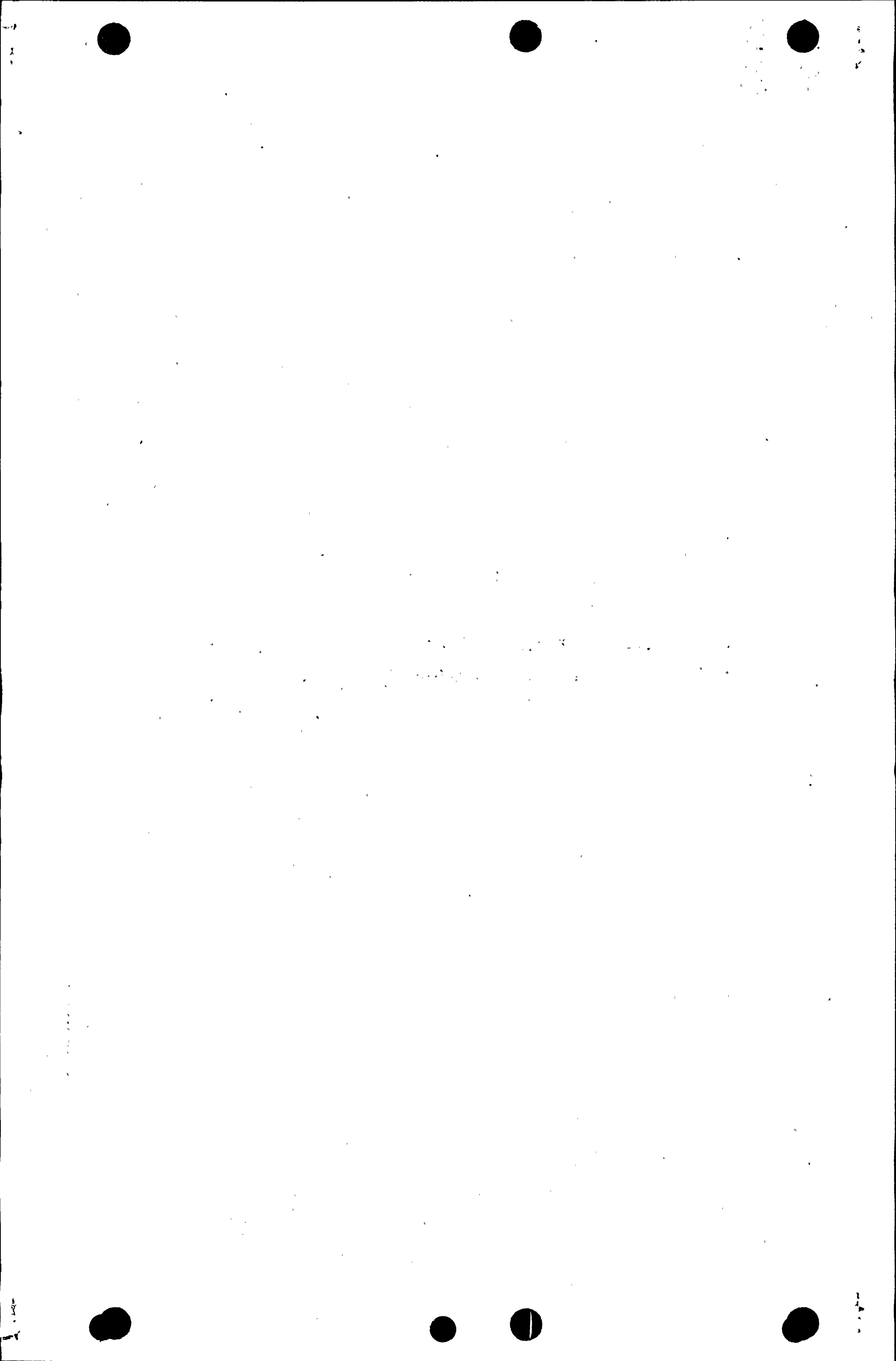

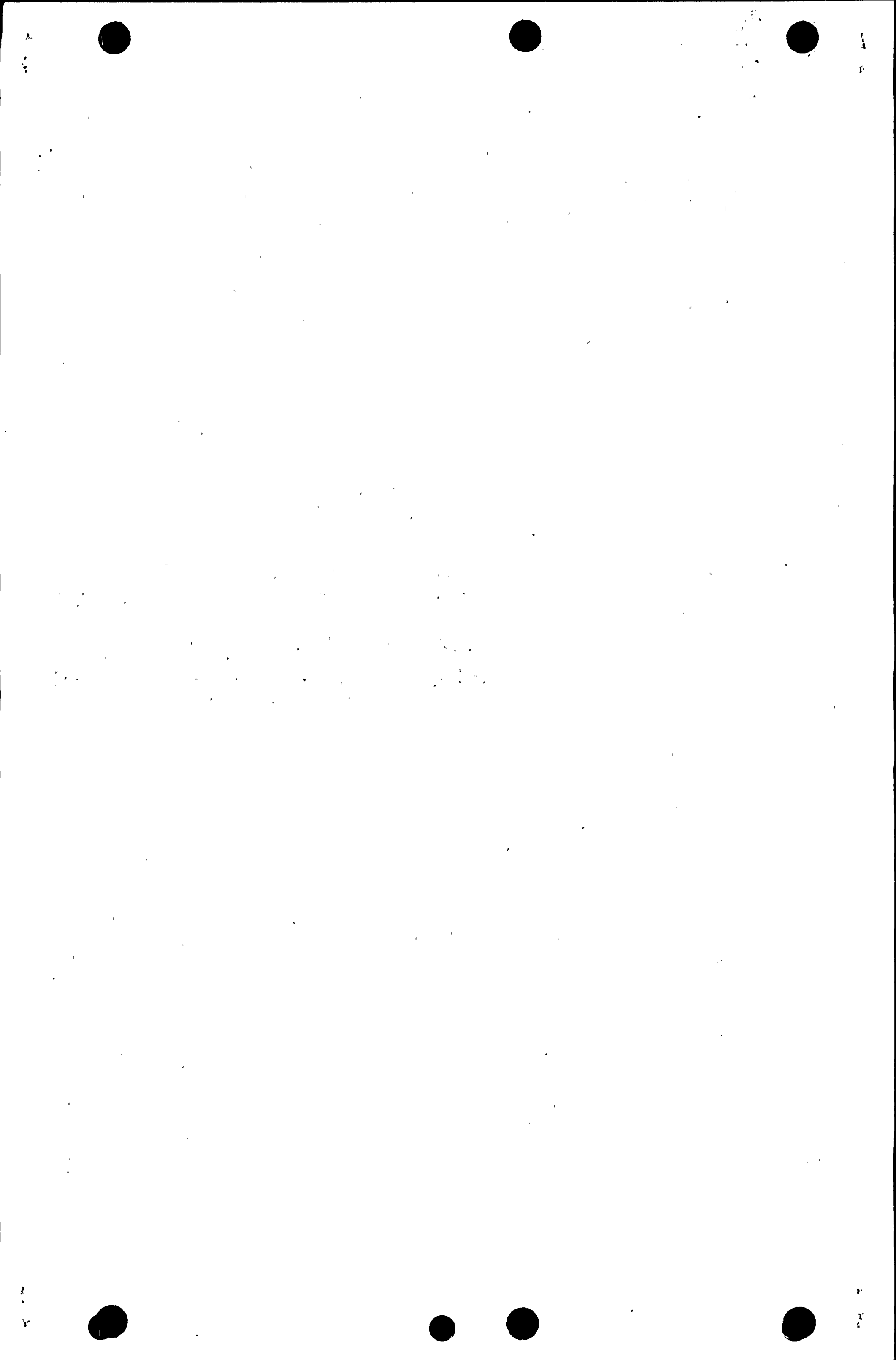

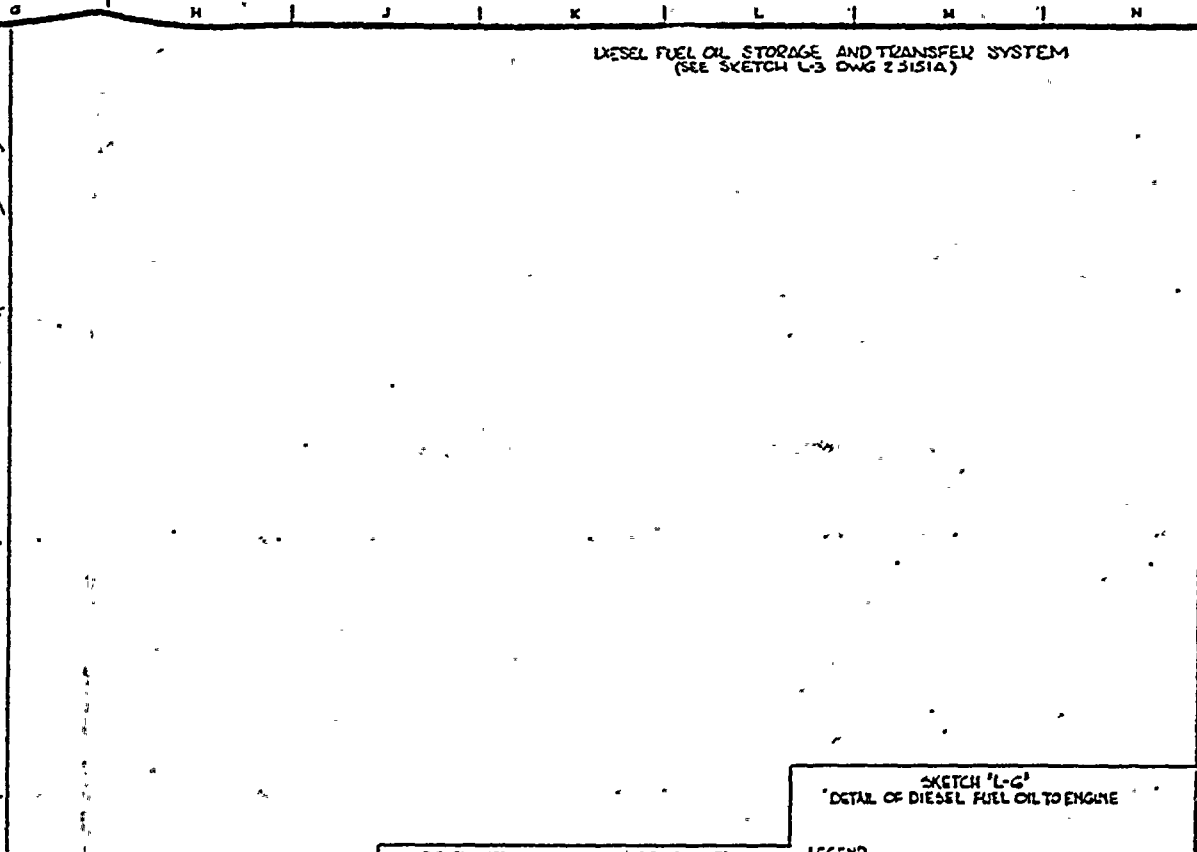
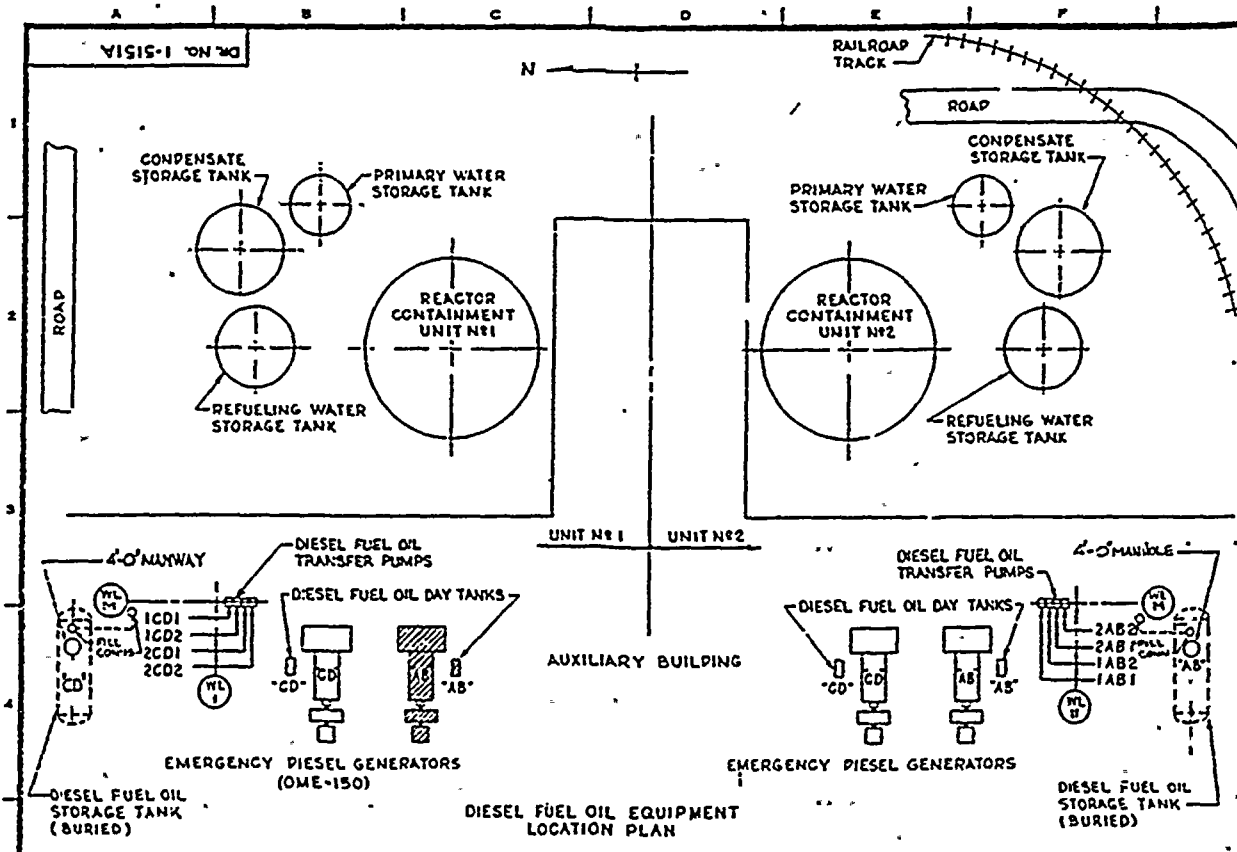

GENERAL NOTES

LEGEND
AS NOTED

SYMBOLS
BY WORTHINGTON
PIPING AND VALVES FURNISHED BY [Symbol] ARE NOTED.

FOR VALVE, INSTRUMENT, SAMPLING, PIPE MATERIAL AND OTHER SYMBOLS NOT EXPLAINED ON THIS DWG., AND FOR MARK NUMBER CODES, SEE DWG. 5104.

ALL DIESEL-GENERATORS INCLUDING THEIR AUXILIARIES, STORAGE TANKS AND PIPING ARE SEISMIC CLASS I EXCEPT AS NOTED.

THE UNIT PREFIX DESIGNATION FOR EACH COMPONENT IDENTIFICATION NUMBER IS UNLESS OTHERWISE NOTED.

NOTE A, H5 ENCIRCLED LETTERS ARE SHOWN FOR ORIENTATION OF VALVE IN PIPING. THESE LETTERS REFLECT SIMILAR MARKINGS ON VALVE BODY.

ALL PIPING TO BE CLASS [Symbol] OR [Symbol] FOR EMBEDDED EXCEPT AS NOTED

ALL PIPING / EQUIPMENT TO BE SEE CODE CLASS 3 EXCEPT AS NOTED.

FOR THE CODE CLASS 3 INSTRUMENT CODE, THE 1/2" BOREWORK EXTENDS TO INCLUDE THE FULL BODY VALVE.

FOR THE CODE CLASS 3 VALVES AND MOUNTS, THE 1/2" BOREWORK EXTENDS TO INCLUDE THE FULL BODY, NORMALLY CLOSED, VALVE.

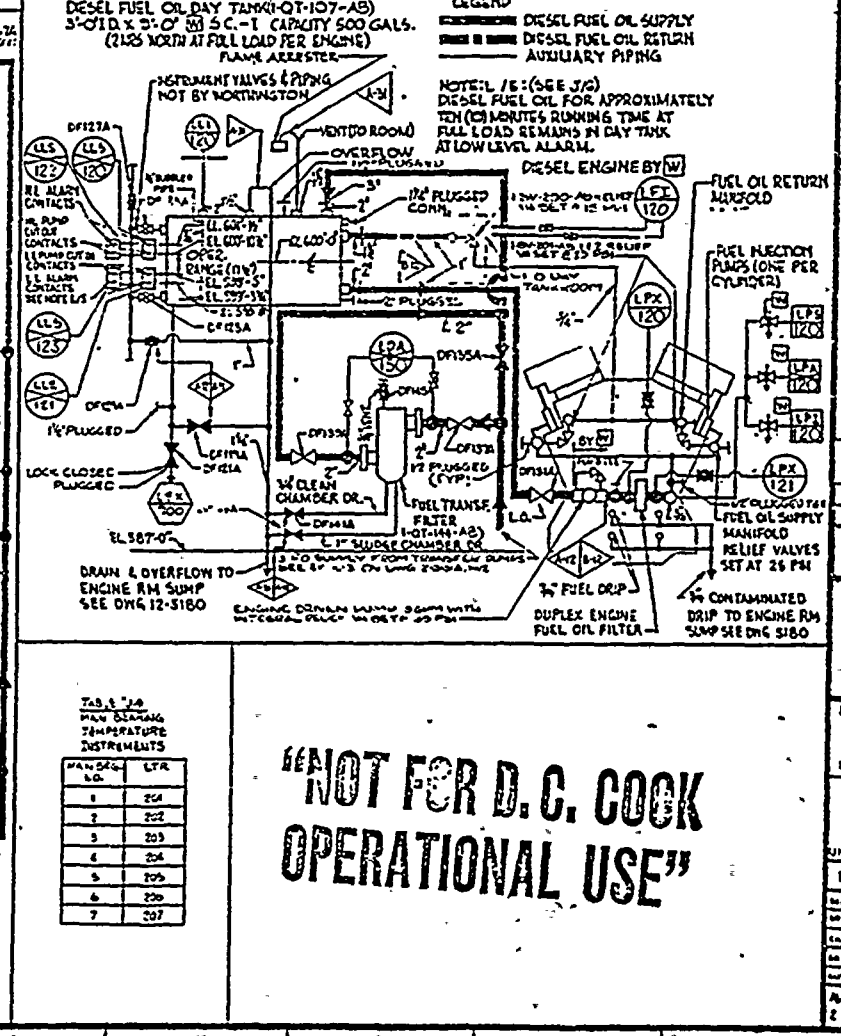
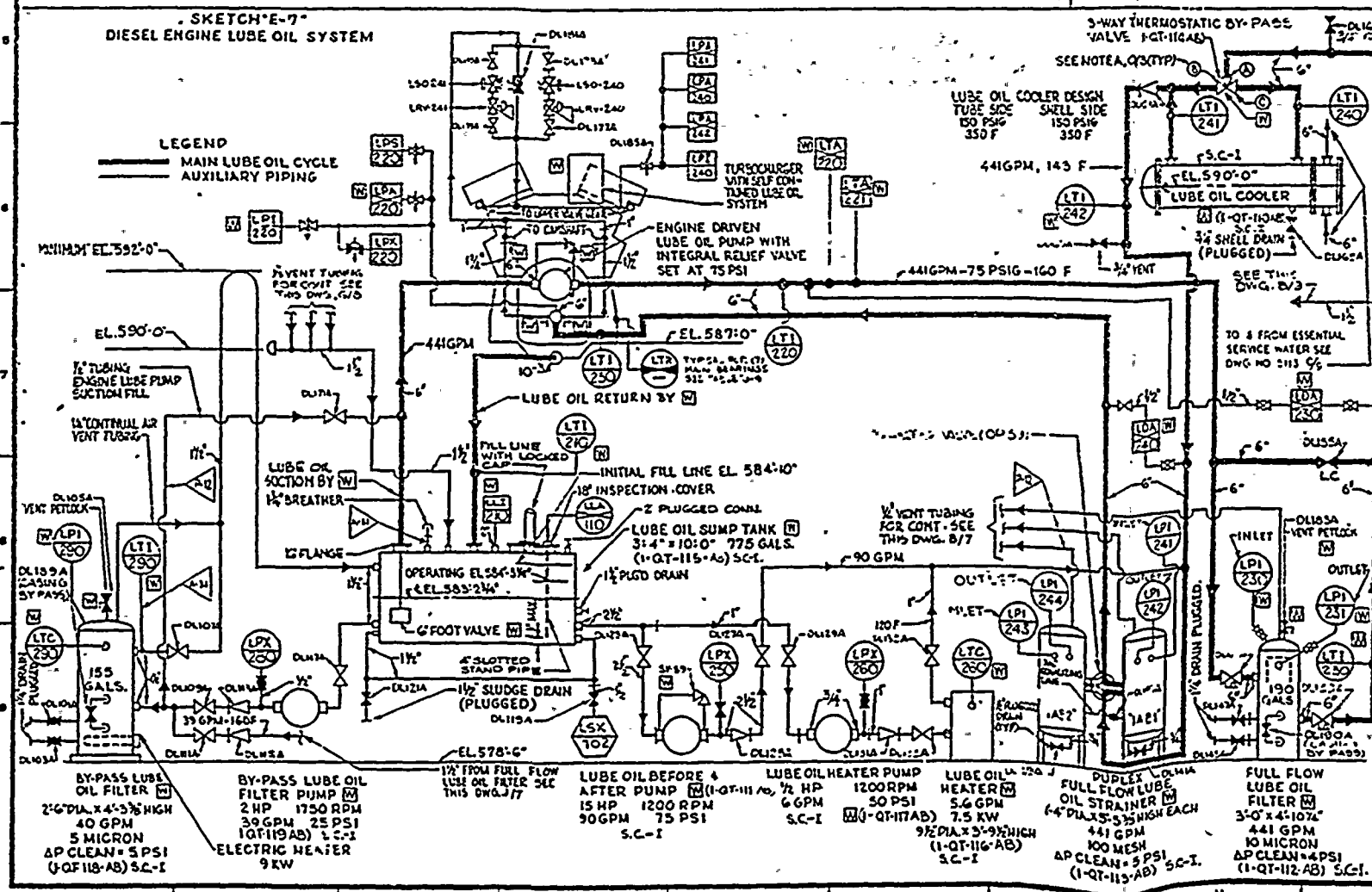

Also Available On Aperture Card

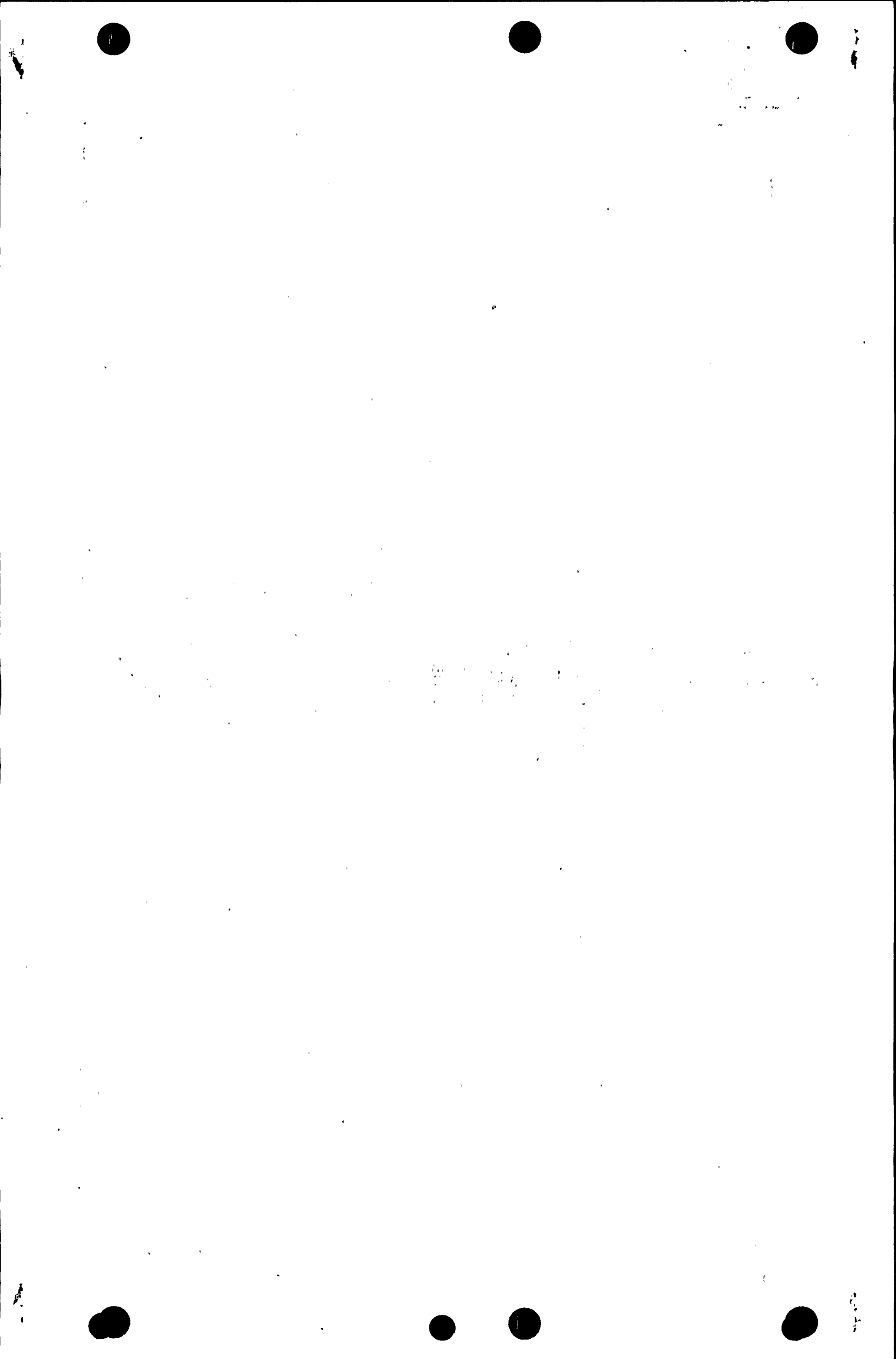

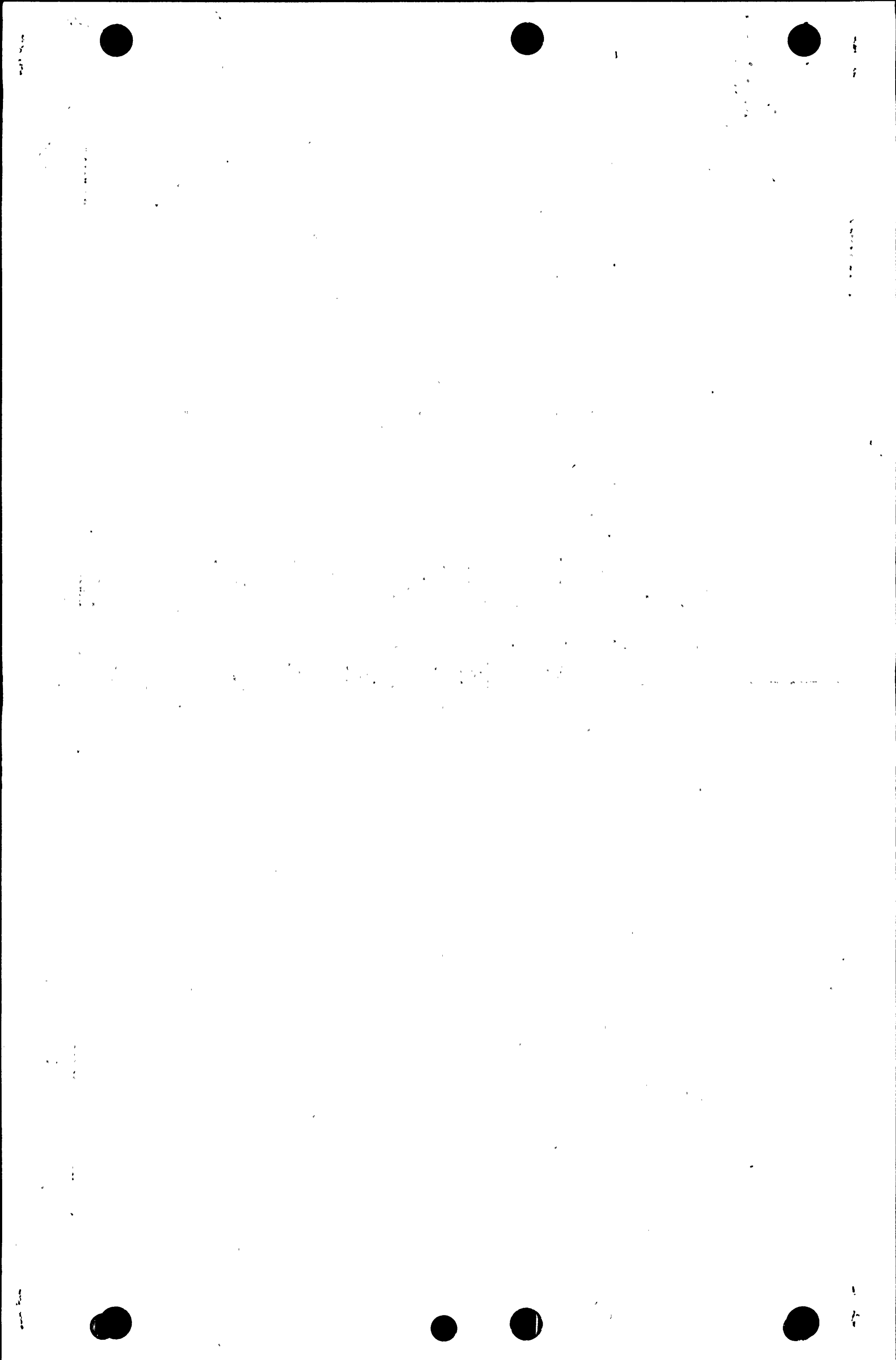

Also Available On
Aperture Card

GENERAL NOTES

LEGEND
AS NOTED

SYMBOLS
BY WORTHINGTON
PIPING AND VALVES FURNISHED BY ARE NOTED.
FOR VALVE, INSTRUMENT, SAMPLING, PIPE MATERIAL AND OTHER SYMBOLS NOT EXPLAINED ON THIS DWG., AND FOR MARK NUMBER CODES, SEE DWG. 12-5103 & 12-5104.

ALL DIESEL GENERATORS, INCLUDING THEIR AUXILIARIES, STORAGE TANKS AND PIPING ARE SEISMIC CLASS I EXCEPT AS NOTED.

NOTE A, W5 ENCIRCLED LETTERS ARE SHOWN FOR ORIENTATION OF VALVE IN PIPING. THESE LETTERS REFLECT SIMILAR MARKINGS ON VALVE BODY.

ALL PIPING TO BE CLASS 3 EXCEPT AS NOTED

ALL PIPING / EQUIPMENT TO BE THE CODE CLASS 3 EXCEPT AS NOTED.

FOR THE CODE CLASS 3 INSTRUMENT CODE THE 2ND CHARACTER EXTENDS TO INCLUDE THE FIRST FOOT VALUE.

FOR THE CODE CLASS 3 VALVES AND DRIVES THE 2ND CHARACTER EXTENDS TO INCLUDE THE 1ST CHARACTER, UNLESS OTHERWISE NOTED.

THE UNIT PREFIX DESIGNATION FOR EACH COMPONENT IDENTIFICATION NUMBER IS "I" UNLESS OTHERWISE NOTED.

NOTE: THIS DWG. MADE UNIQUE FOR UNIT #1 "CD" AND SUPERSEDED DWG. 1-5150 REV. 19.

HAND OPERATED VALVE IDENTIFICATION NUMBERS
1. ONLY "UNIQUE VALVE NUMBERS" APPEAR ON THIS DRAWING. SEE SEPARATE VALVE IDENTIFICATION LIST FOR EQUIVALENT DESIGN (MCR) NUMBERS.
2. "TAG" NUMBERS MODIFIED FOR DRAWING USE AS FOLLOWS:
TAG NO: 2-NP-100-W APPEARS AS: 2N100W
3. INSTRUMENT ROOT VALVE MARKS ARE NOT SHOWN ON DRAWING (SEE VALVE IDENTIFICATION LIST) DERIVED BY ADDING TO INSTRUMENT NUMBER, FOR SINGLE INLET, FOR DOUBLE INLET, UPSTREAM AND DOWNSTREAM.

FOR MICROFILM STATUS SEE REVISION RECORD FOR THIS DWG.

1-6-87 26/200/200
DATE NO. APPROVED:

FOR REVISION DESCRIPTION SEE SEPARATE REVISION RECORD FOR THIS DRAWING.

"THIS DRAWING IS THE PROPERTY OF THE AMERICAN ELECTRIC POWER SERVICE CORP. AND IS LOANED TO THE USER UNDER THE CONDITION THAT IT IS TO BE RETURNED TO THE AMERICAN ELECTRIC POWER SERVICE CORP. WITH ALL REVISIONS AND CHANGES MADE THEREON. IT IS NOT TO BE REPRODUCED OR TRANSMITTED IN ANY FORM OR BY ANY MEANS, ELECTRONIC OR MECHANICAL, INCLUDING PHOTOCOPYING, RECORDING, OR BY ANY INFORMATION STORAGE AND RETRIEVAL SYSTEM, WITHOUT THE WRITTEN PERMISSION OF THE AMERICAN ELECTRIC POWER SERVICE CORP."

INDIANA & MICHIGAN ELECTRIC CO.
DONALD C. COOK
NUCLEAR PLANT

FLOW DIAGRAM
EMERGENCY DIESEL
GENERATOR "CD"

UNIT NO. 1
DWG. NO. 1-5151C-26

AMERICAN ELECTRIC POWER SERVICE CORP.
2 BROADWAY NEW YORK

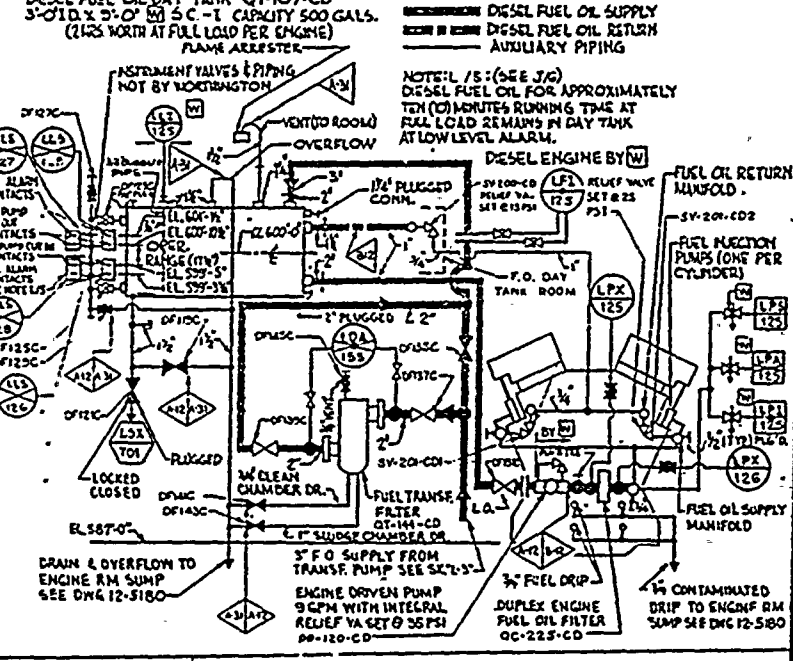
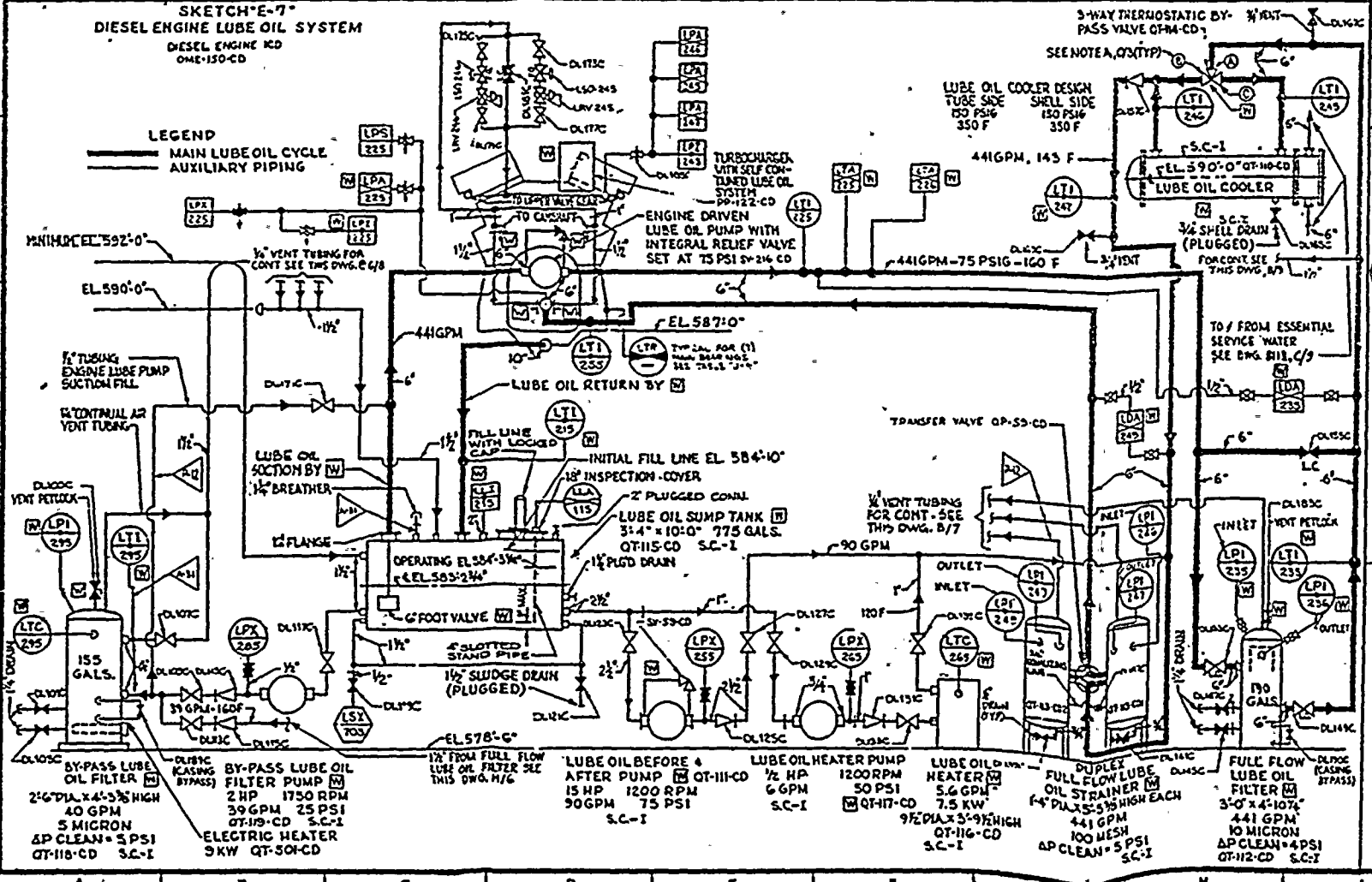
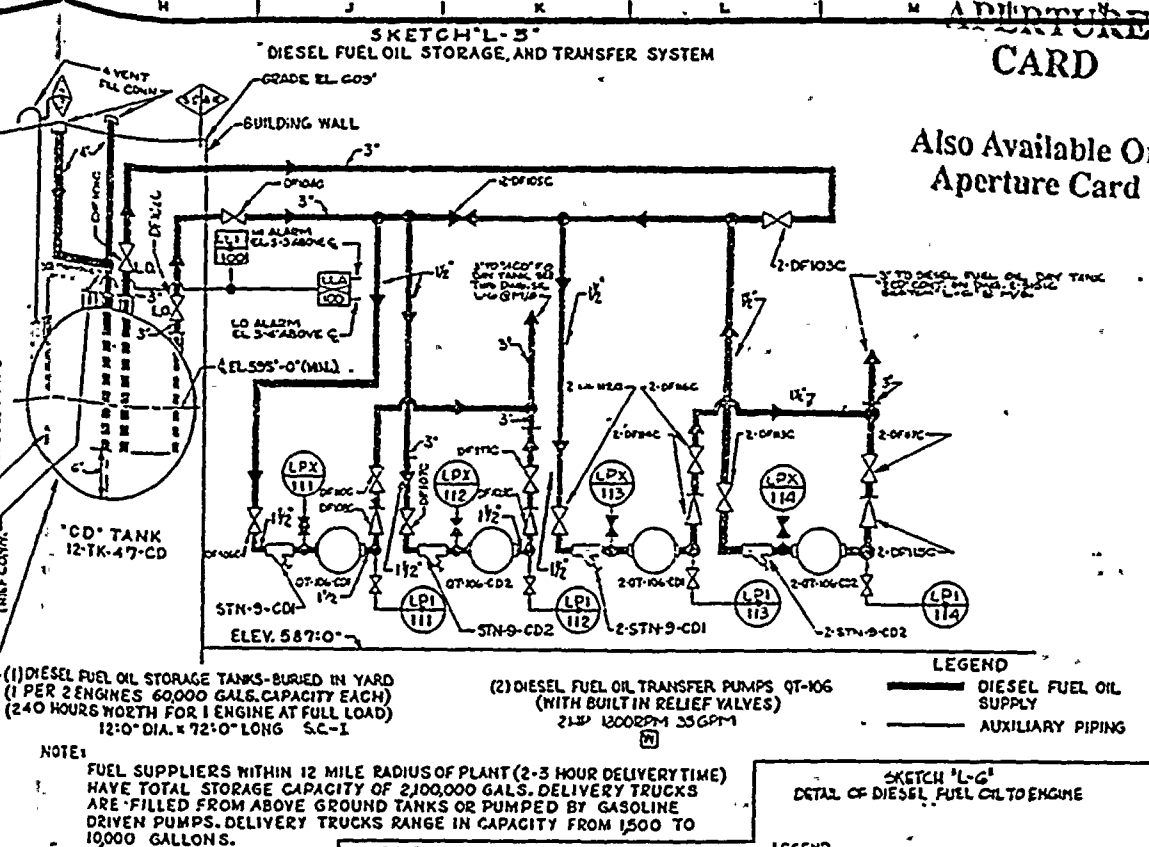
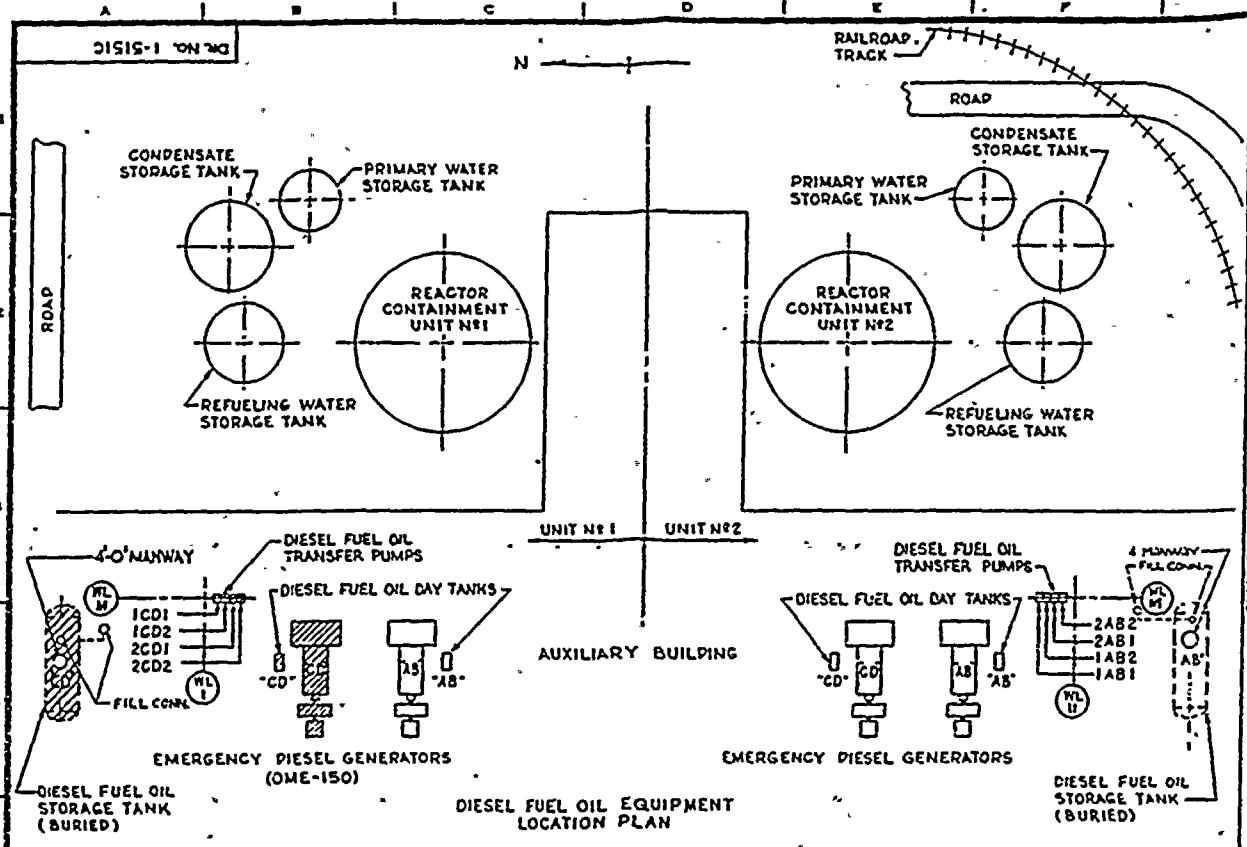
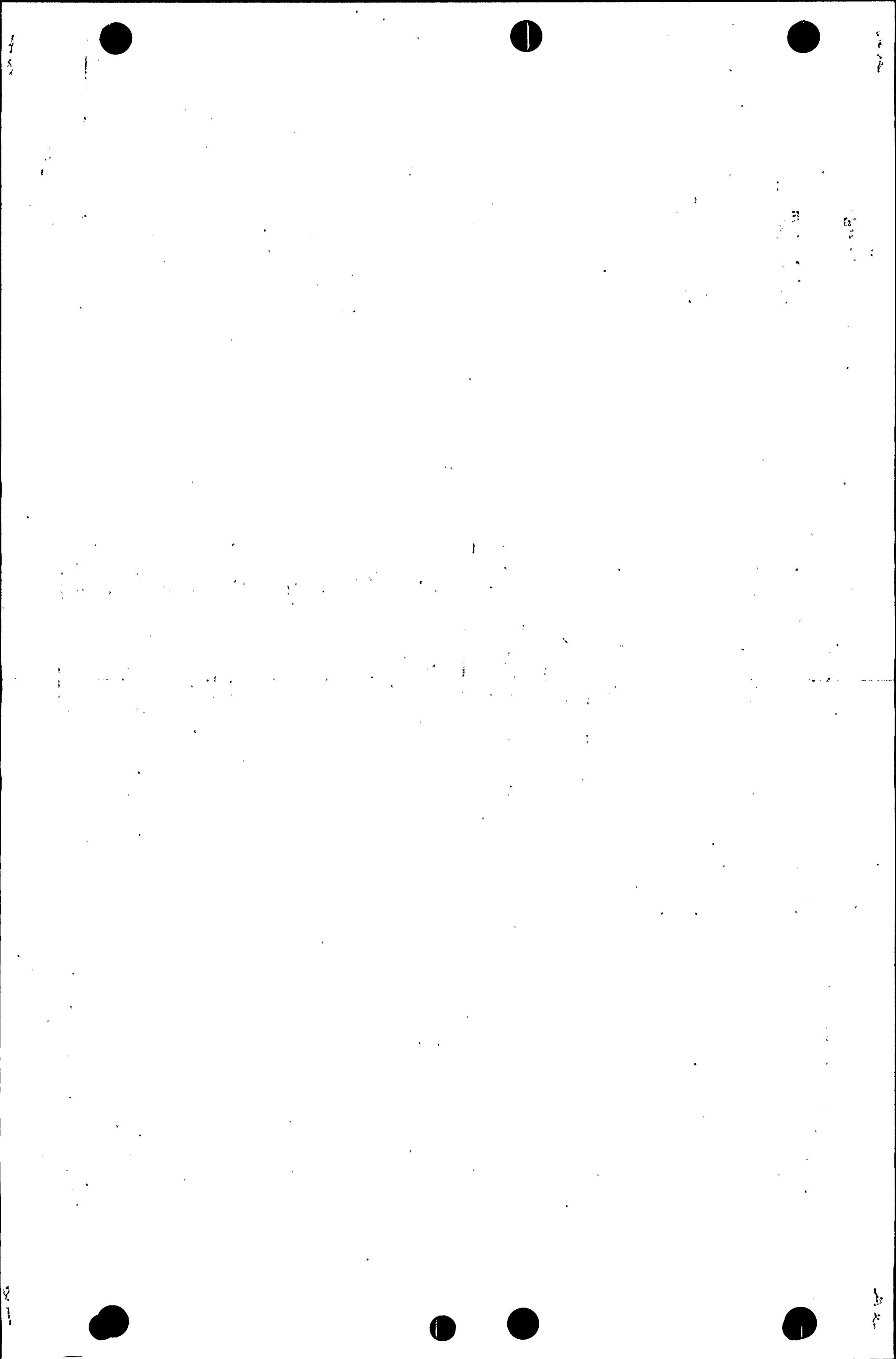
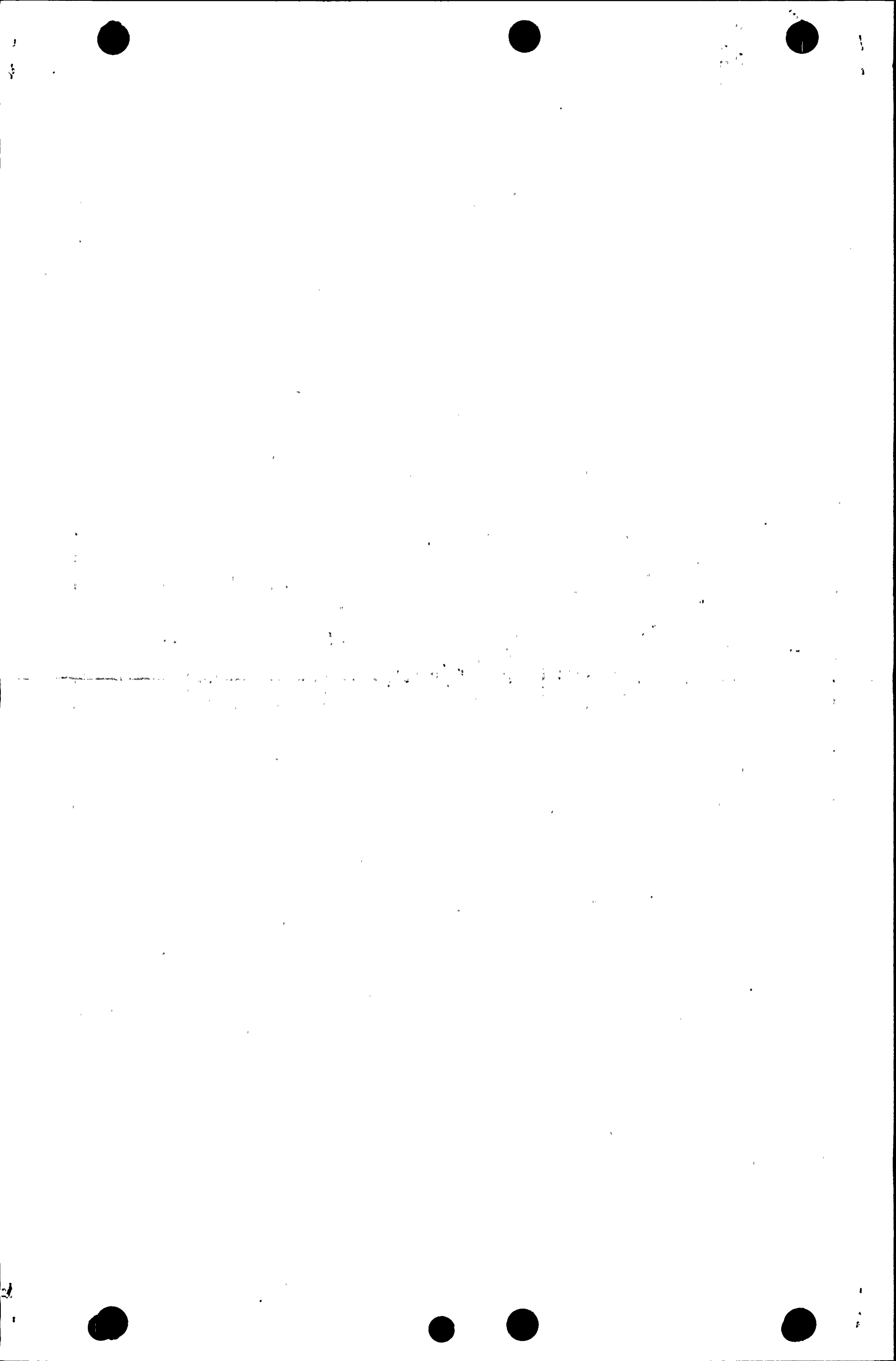

TABLE 3-9
MAIN DRIVING TEMPERATURE INSTRUMENTS

MAN. NO.	TEMP.	LTR.
1	21	
2	22	
3	23	
4	24	
5	25	
6	26	
7	27	

**"NOT FOR D. C. COOK
OPERATIONAL USE"**





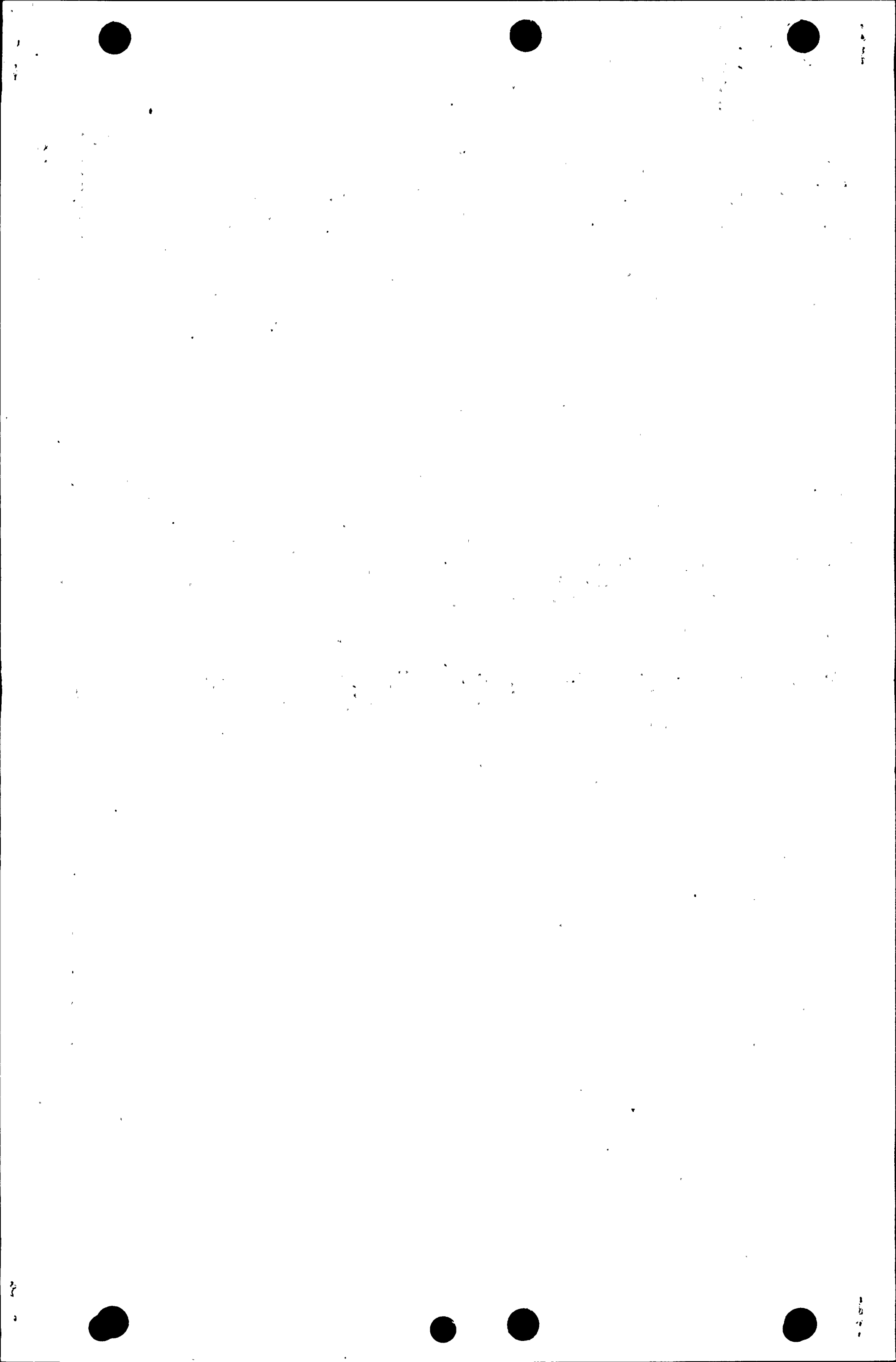

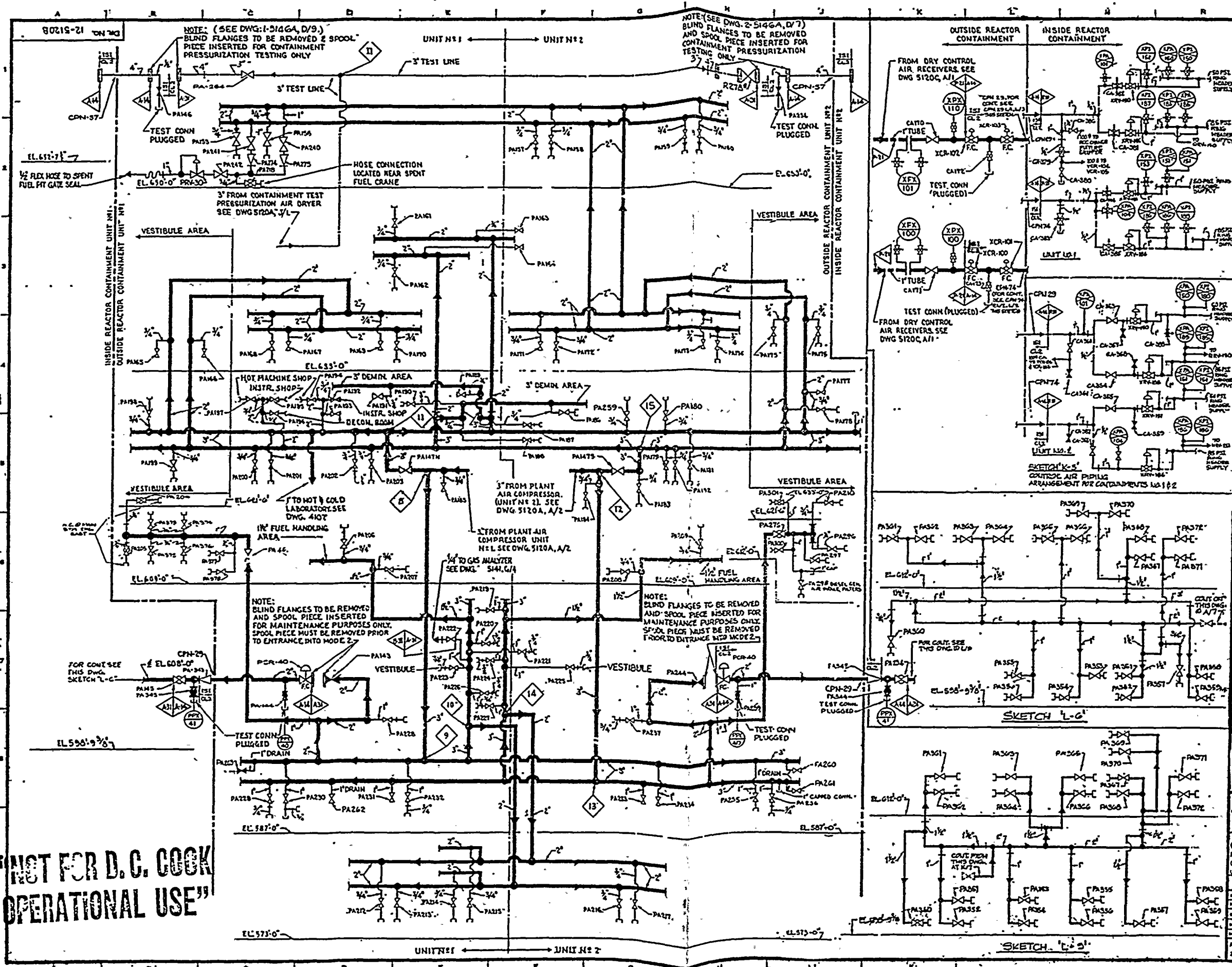

GENERAL NOTES

LEGEND

- PLANT AIR
- DEHUMIDIFIED CONTROL AIR PIPING
- CONTAINMENT TEST PRESSURIZATION AIR PIPING
- AUXILIARY PIPING

SYMBOLS

- HOSE CONN. TYPICAL FOR 3/4\" CONN'S EXCEPT AS NOTED

FOR VALVE, INSTRUMENT, SAMPLING, PIPE MATERIAL AND OTHER SYMBOLS NOT EXPLAINED ON THIS DWG. AND FOR MARK NUMBER CODES, SEE DWG. 5104

ALL PIPING TO BE A-31 UNLESS OTHERWISE NOTED

NO EQUIPMENT SHOWN FOR SEISMIC CLASS DESIGNATION

FOR VALVE, INSTRUMENT, SAMPLING, PIPE MATERIAL AND OTHER SYMBOLS NOT EXPLAINED ON THIS DWG. AND FOR MARK NUMBER CODES, SEE DWG. 5104

THE LAST PREFIX DESIGNATION FOR EACH COMPONENT IDENTIFICATION NUMBER IS 12 UNLESS OTHERWISE NOTED

HAND OPERATED VALVE IDENTIFICATION NUMBERS ONLY "TRIPLE VALVE NUMBERS" APPEAR ON THIS DRAWING. SEE SEPARATE VALVE IDENTIFICATION LIST FOR EQUIVALENT DESIGN (MCA) NUMBERS.

TRIPLE NUMBERS IDENTIFIED DRAWING USE AS FOLLOWS:

- TAG #1: 2-NOM-100-W APPEARS AS: 100100W
- INSTRUMENT ROOT VALVE MARK IF NOT SHOWN ON DRAWING (SEE VALVE IDENTIFICATION LIST) DERIVED BY ADDING TO INSTRUMENT NUMBER:
- FOR SINGLE DIRECTIVE FOR DOUBLE INFLUENCE VAPORSTREAM V22000100W

FOR MICROFORM STATUS SEE REVISION RECORD FOR THIS DWG.

DATE: 10-23-72
 DRAWN BY: [Signature]
 APPROVED BY: [Signature]

FOR REVISION DESCRIPTION SEE SEPARATE REVISION RECORD FOR THIS DRAWING

INDIANA & MICHIGAN ELECTRIC CO.
 DONALD C. COOK
 NUCLEAR PLANT

FLOW DIAGRAM
 COMPRESSED AIR SYSTEM
 PLANT AIR ALIX. BLDG. & CONTAINMENT CONTROL AIR FOR CONTAINMENT UNITS #1 & 2

DWG. NO. 12-5120B-22

AMERICAN ELECTRIC POWER SYSTEM CORP.
 2 BROADWAY

SI APERTURE CARD

Also Available On Aperture Card

"NOT FOR D. C. COOK OPERATIONAL USE"

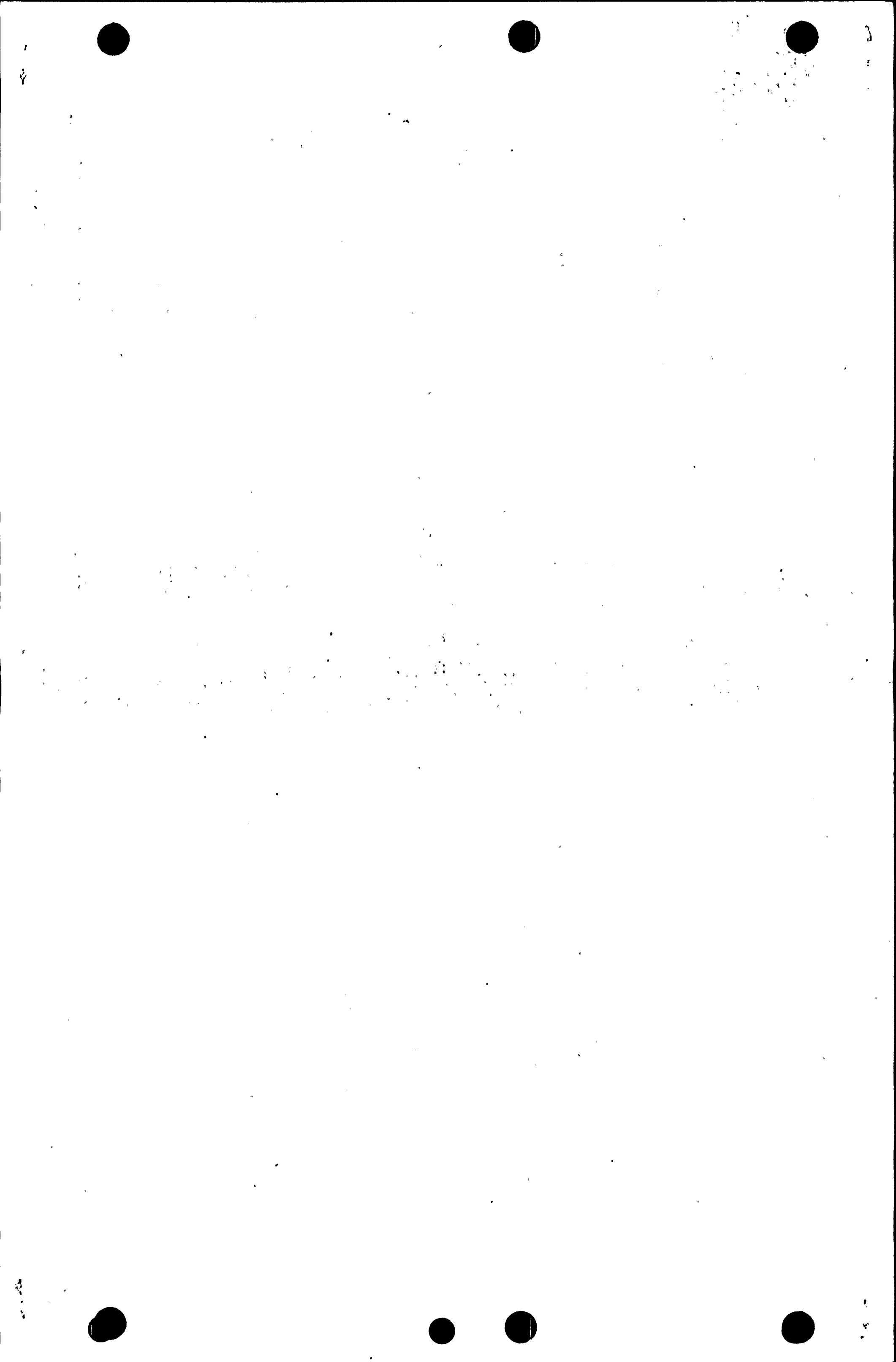

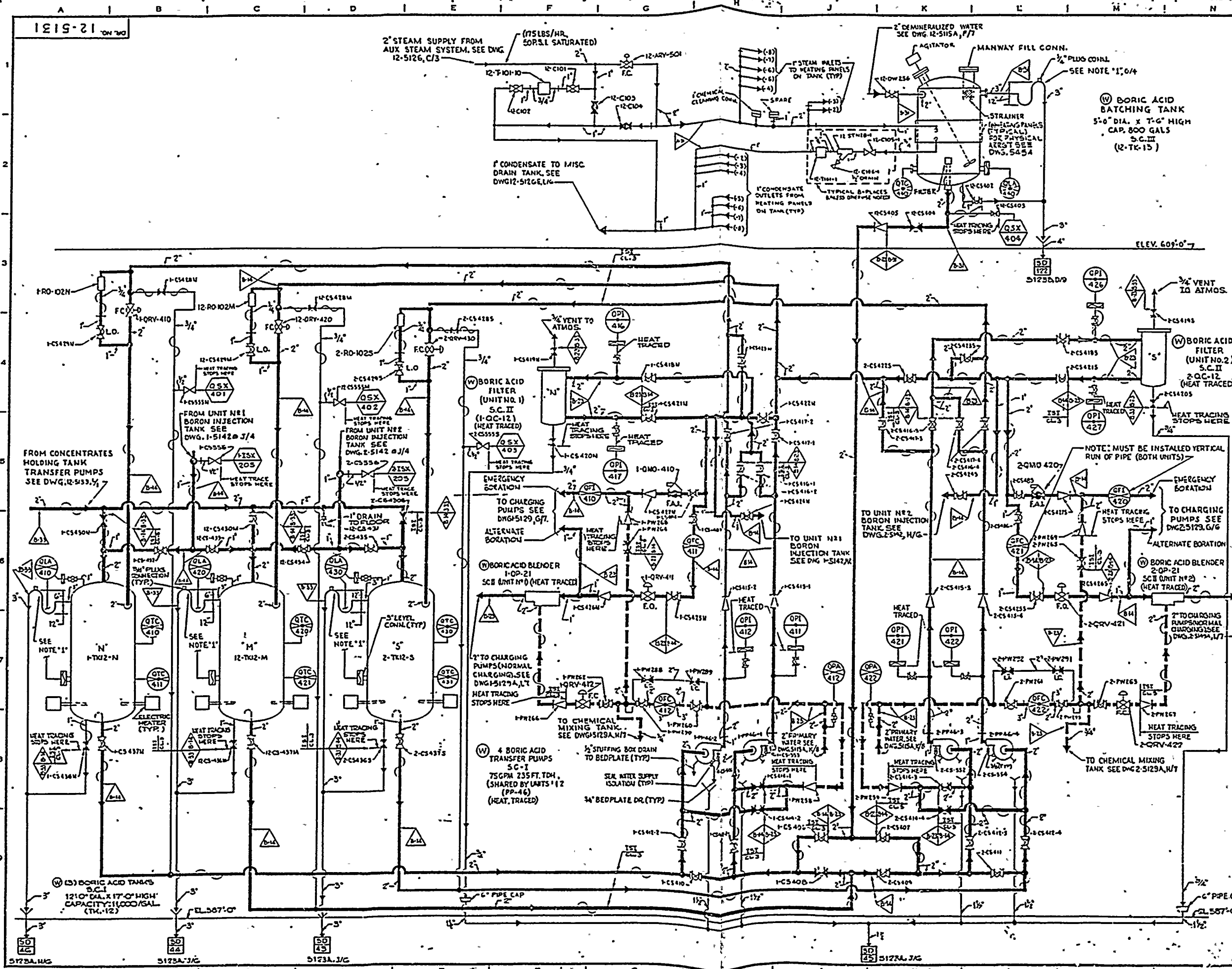

GENERAL NOTES

LEGEND

- BORATED WATER
- PRIMARY WATER
- AUXILIARY PIPING
- SYMBOLS
- DIAPHRAGM SEAL

FOR VALVE, INSTRUMENT SAMPLING, PIPE MATERIAL AND OTHER SYMBOLS NOT EXPLAINED ON THIS DWG., AND FOR MARK NUMBER, COOLS, SEE DWG'S 12503 & 5104.

BY WESTINGHOUSE

ALL VALVES AND INSTRUMENTATION SUPPLIED BY WESTINGHOUSE EXCEPT AS NOTED.

EQUIPMENT SUPPLIED BY WESTINGHOUSE AS NOTED.

NOTE: 1" A/G, C/G, D/G, L/I OVERFLOW LOOP SEALS TO BE FILLED WITH DEMINERALIZED WATER. WHENEVER TANKS ARE OVERFLOWED, LOOP SEALS ARE TO BE FLUSHED TO PREVENT BORIC ACID CRYSTALLIZATION.

SEISMIC CLASSIFICATION OF EQUIPMENT AS NOTED

NOTES

FOR CLASS'S INSTRUMENT CONNECTIONS THE 1ST BRUNNEN EXTENSION INCLUDES THE FIRST ROOT VALVE

THE UNIT PREFIX DESIGNATION FOR EACH COMPONENT IDENTIFICATION NUMBER IS '12' UNLESS OTHERWISE NOTED

HAND OPERATED VALVE IDENTIFICATION NUMBERS

1. ONLY "UNIQUE VALVE NUMBERS" APPEAR ON THIS DRAWING. SEPARATE VALVE IDENTIFICATION LIST FOR EQUIVALENT DESIGN (MCR) NUMBERS.

2. "TAG" NUMBERS MODIFIED FOR DRAWING USE AS FOLLOWS: TAG NO. 2-NSW002-W APPEARS AS: NSW002

3. INSTRUMENT ROOT VALVE MARK N'S NOT SHOWN ON DRAWING (SEE VALVE IDENTIFICATION LIST) DERIVED BY ADDING TO INSTRUMENT NUMBER: FOR SINGLE IMPLSE, VI FOR DOUBLE IMPLSE, VALPSTREAM/VS200MSTRV

FOR MICROFILM STATUS SEE REVISION RECORD FOR THIS DWG

4-8-57 19 *For ASD*

DATE NO APPROVED

FOR REVISION DESCRIPTION SEE SEPARATE REVISION RECORD FOR THIS DRAWING

INDIANA & MICHIGAN ELECTRIC CO.
DONALD C. COOK
NUCLEAR PLANT

BRIDGMAN MICROCAP

**FLOW DIAGRAM
CVCS-BORON
MAKE-UP
UNITS NO 1 & 2**

DPL NO. 12-5131-19

AMERICAN ELECTRIC POWER SERVICE
2 BROADWAY

NOT A CONTROLLED COPY

SI APERTURE CARD

Also Available On Aperture Card

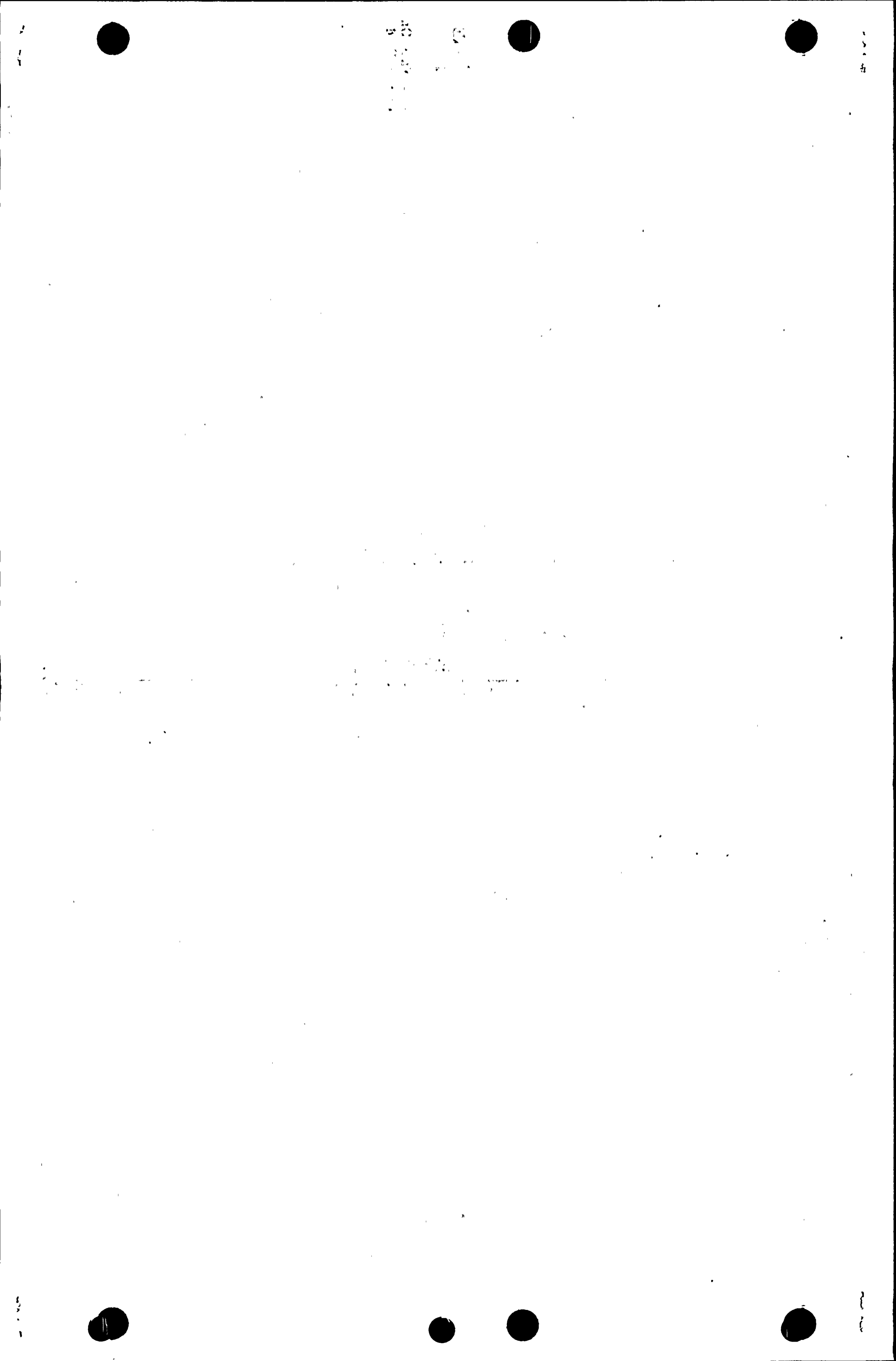

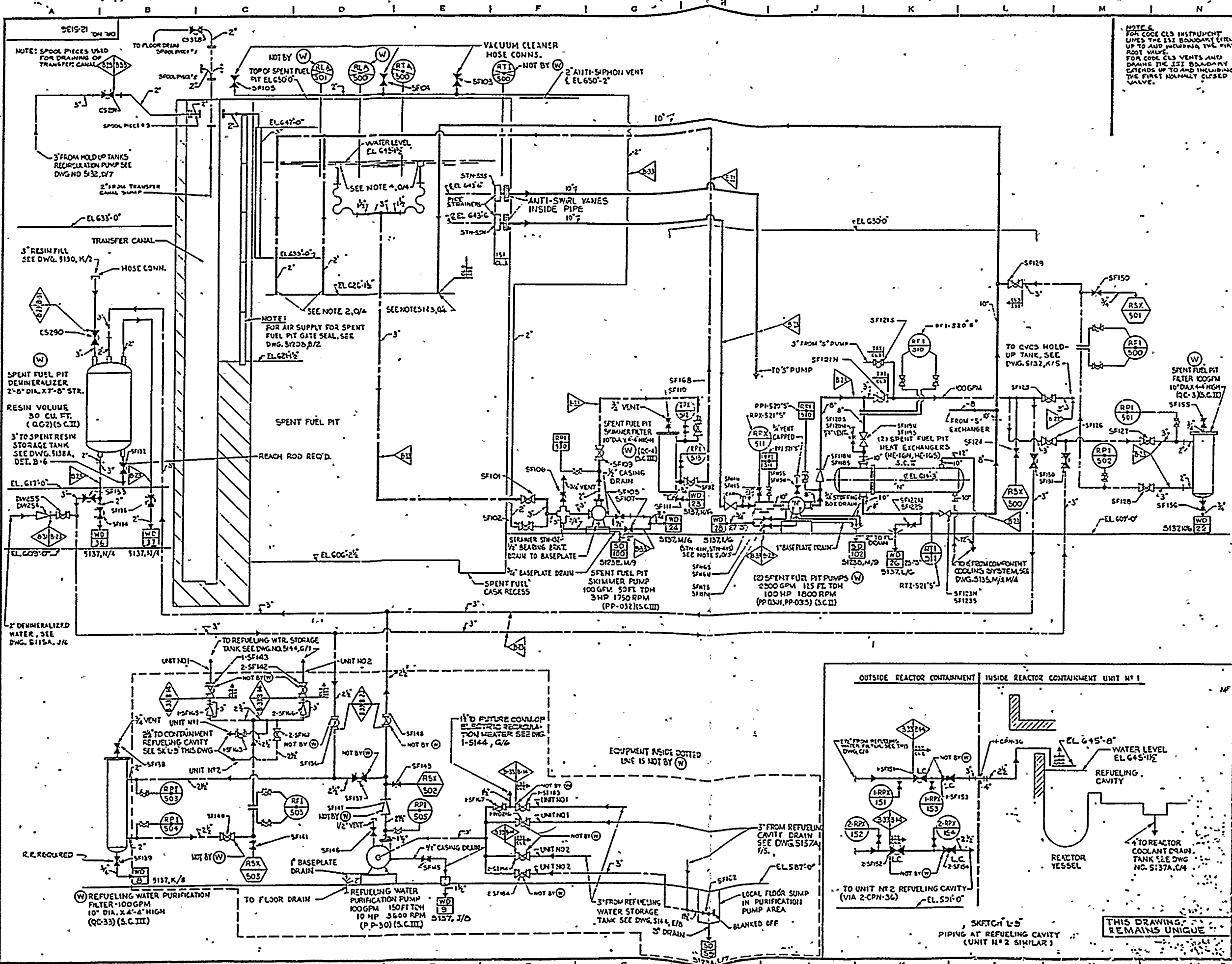

NOTE: FOR CODE CLS INSTRUMENT LINES THE ISE BOUNDARY (FIELD) ROOT VALVE. FOR CODE CLS VENTS AND DRAINS THE ISE BOUNDARY EXTENDS UP TO AND INCLUDING THE FIRST NORMALLY CLOSED VALVE.

GENERAL NOTES

LEGEND

- SPENT FUEL PIT
- COOLING WATER
- SKIMMER CLEANUP
- AUX. PIPING
- WATER PURIFICATION

FOR VALVE, INSTRUMENT SAMPLING, PIPE MATERIAL AND OTHER SYMBOLS NOT EXPLAINED ON THIS DWG., AND FOR MARK NUMBER CODES SEE DWG. 12-5103 & 12-5104.

EQUIPMENT SEISMIC CLASS AS NOTED.

(W) BY WESTINGHOUSE

ALL VALVES & INSTRUMENTATION BY (W) EXCEPT AS NOTED

EQUIPMENT SUPPLIED BY (W) AS NOTED

NOTE 1: LOCATE 1/2" HOLE IN PIPE 4" BELOW WATER LINE

NOTE 2: LOCATE 1/4" HOLE IN PIPE 4" BELOW WATER LINE

NOTE 3: TERMINATE PIPE ABOVE FUEL ASSEMBLIES

NOTE 4: SET ADJUSTABLE SUPPORT ON SKIMMERS TO LIMIT DOWN TRAVEL TO 2" BELOW NORMAL WATER LEVEL

NOTE 5: TEE-TYPE STRAINER WITH TEMPORARY SCREEN FOR USE DURING PREOPERATIONAL FLUSHING. (LOCATE AS CLOSE TO PUMP AS POSSIBLE)

NOTE 6: THE UNIT PERFORMS DESIGN FUNCTIONS FOR 24 HOURS CONTINUOUSLY. ALL VALVES ARE NORMALLY CLOSED UNLESS OTHERWISE NOTED.

HAND OPERATED VALVE IDENTIFICATION NUMBERS

1. ONLY UNIQUE VALVE NUMBERS APPEAR ON THIS DRAWING. SEE SEPARATE VALVE IDENTIFICATION LIST FOR EQUIPMENT DESIGN (MCR) NUMBERS.

2. TAG NUMBERS MODIFIED FOR DRAWING USE AS FOLLOWS:

- TAG NO. 2-NON-VOLV W APPEARS AS: NSVICW
- INSTRUMENT ROOT VALVE MARK N'S NOT SHOWN ON DRAWING (SEE VALVE IDENTIFICATION LIST) DERIVED BY ADDING TO INSTRUMENT NUMBERS:
- FOR SINGLE IMPULSE: V
- FOR DOUBLE IMPULSE: VDP
- FOR STREAM: VST
- FOR COOLANT: VCO

DATE: 3-11-82

FOR REVISION DESCRIPTION SEE SEPARATE REVISION RECORD FOR THIS DRAWING

INDIANA & MICHIGAN ELECTRIC CO.

DONALD C. COOK

NUCLEAR UNIT

FLOW DIAGRAM SPENT FUEL PIT COOLING & CLEAN-UP UNIT 1 & 2

EXCEPTIONS ARE NOTED

DR. NO. 12-5136-25

NO.	DATE	BY	CHKD.	APP'D.
1	3-11-82	DC	DC	DC
2				
3				
4				
5				

NOT A CONTROLLED COPY

SI APERTURE CARD

Also Available On Aperture Card

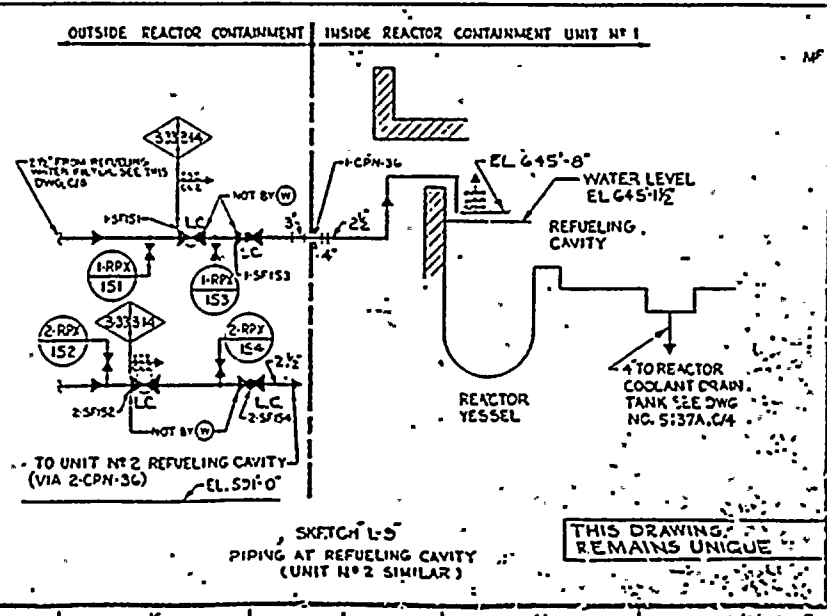

THIS DRAWING REMAINS UNIQUE

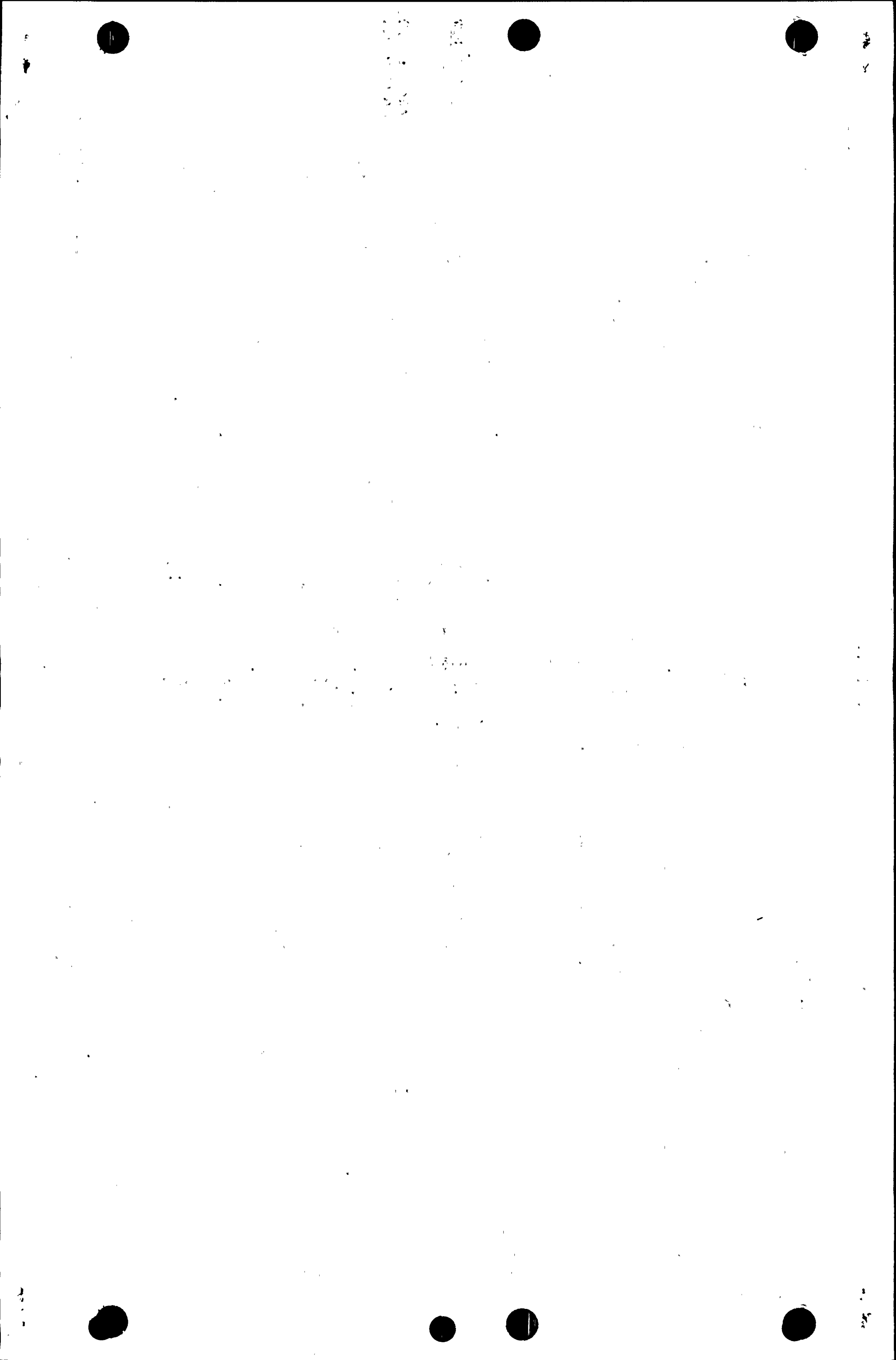

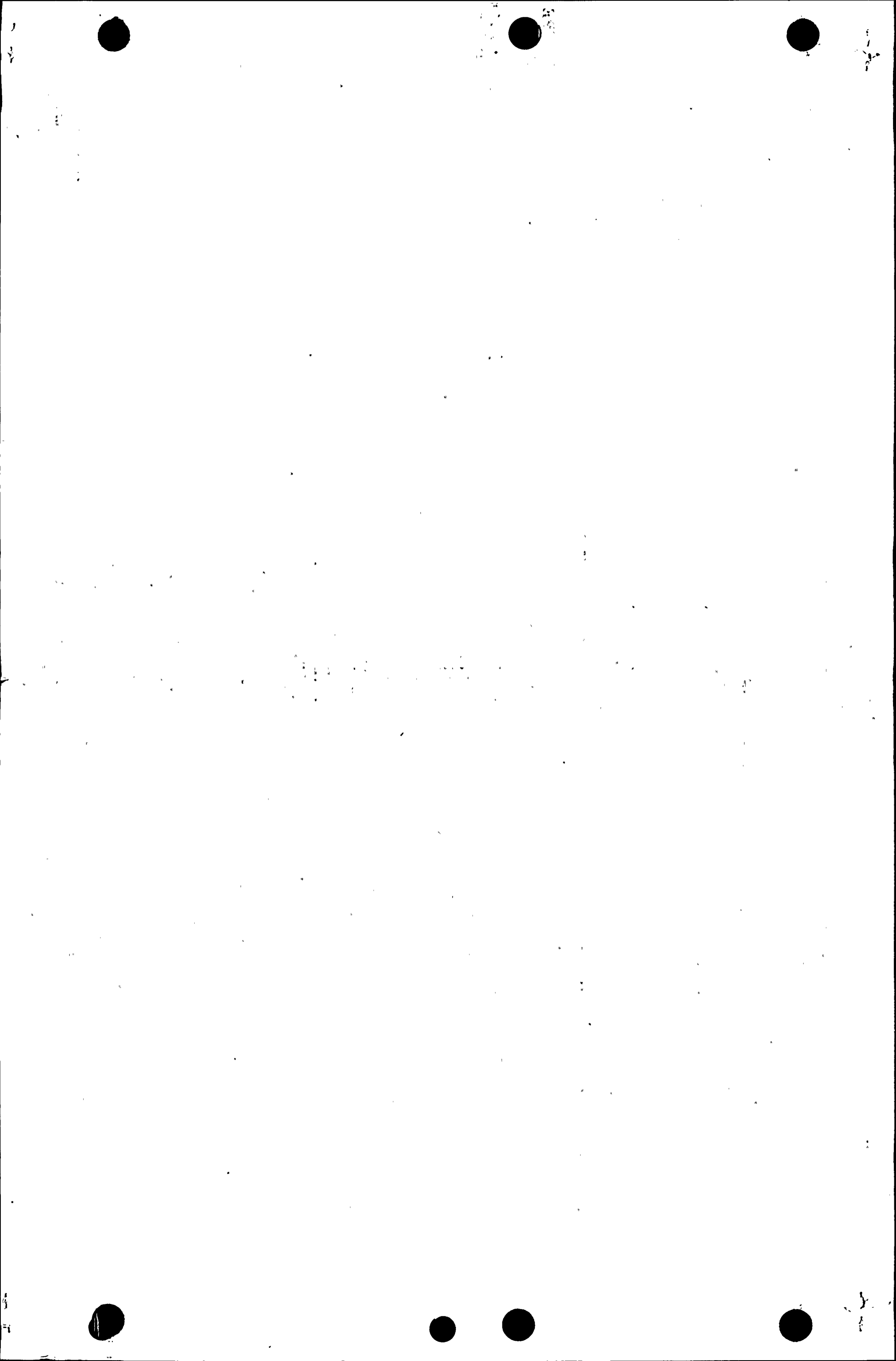

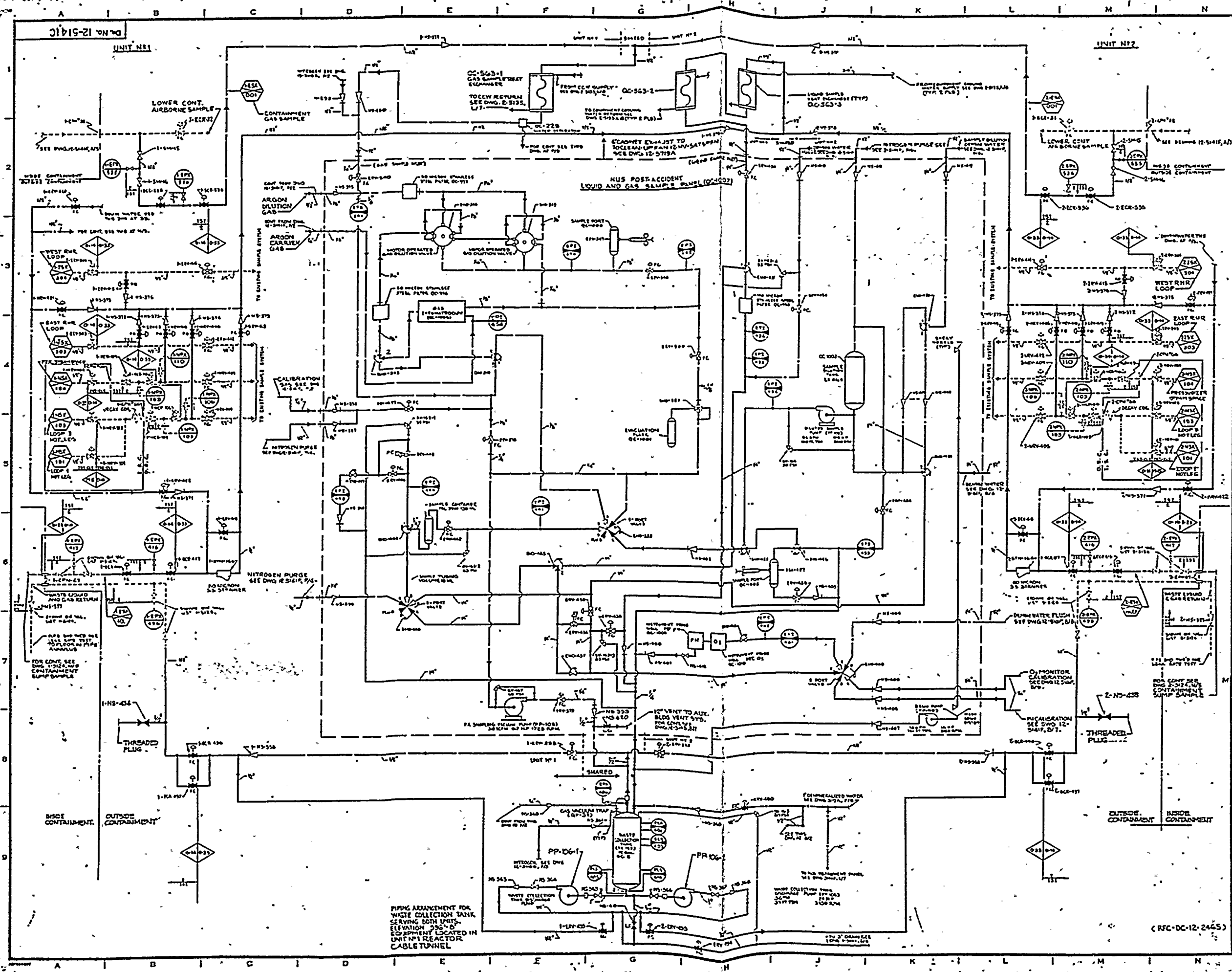

GENERAL NOTES

LEGEND

- LIQUID PIPING
- STEAM/WATER PIPING
- GAS PIPING
- AIRGAS PIPING

NOTES:

- 1) THIS DRAWING IS PER EFC-DC-12-5141C AND NOTES 0137
- 2) FOR DETAILS OF LOWER CONTAINMENT SAMPLE SEE FLOW DIAGRAM 12-5141C AND 12-5141D
- 3) THIS LIQUID AND GAS SAMPLE PANEL IS SHARED BY BOTH UNITS
- 4) ALL EQUIPMENT AND ROOMS TO BE SHOWN EXCEPT AS NOTED
- 5) VALVES AND PIPING SHOWN IN POSITION UNLESS OTHERWISE NOTED
- 6) 1) 2-POSITION VALVE OPENED VALVE
- 7) 3-POSITION VALVE OPENED VALVE
- 8) POSITION NUMBER OPENED VALVE POSITION IS ALWAYS OPEN

SAMPLE COMPLETION TABLE

UNIT	NO.	DATE	BY
1	101	12-28-87	...
1	102	12-28-87	...
1	103	12-28-87	...
1	104	12-28-87	...
1	105	12-28-87	...
1	106	12-28-87	...
1	107	12-28-87	...
1	108	12-28-87	...
1	109	12-28-87	...
1	110	12-28-87	...
1	111	12-28-87	...
1	112	12-28-87	...
1	113	12-28-87	...
1	114	12-28-87	...
1	115	12-28-87	...
1	116	12-28-87	...
1	117	12-28-87	...
1	118	12-28-87	...
1	119	12-28-87	...
1	120	12-28-87	...
1	121	12-28-87	...
1	122	12-28-87	...
1	123	12-28-87	...
1	124	12-28-87	...
1	125	12-28-87	...
1	126	12-28-87	...
1	127	12-28-87	...
1	128	12-28-87	...
1	129	12-28-87	...
1	130	12-28-87	...
1	131	12-28-87	...
1	132	12-28-87	...
1	133	12-28-87	...
1	134	12-28-87	...
1	135	12-28-87	...
1	136	12-28-87	...
1	137	12-28-87	...
1	138	12-28-87	...
1	139	12-28-87	...
1	140	12-28-87	...
1	141	12-28-87	...
1	142	12-28-87	...
1	143	12-28-87	...
1	144	12-28-87	...
1	145	12-28-87	...
1	146	12-28-87	...
1	147	12-28-87	...
1	148	12-28-87	...
1	149	12-28-87	...
1	150	12-28-87	...
1	151	12-28-87	...
1	152	12-28-87	...
1	153	12-28-87	...
1	154	12-28-87	...
1	155	12-28-87	...
1	156	12-28-87	...
1	157	12-28-87	...
1	158	12-28-87	...
1	159	12-28-87	...
1	160	12-28-87	...
1	161	12-28-87	...
1	162	12-28-87	...
1	163	12-28-87	...
1	164	12-28-87	...
1	165	12-28-87	...
1	166	12-28-87	...
1	167	12-28-87	...
1	168	12-28-87	...
1	169	12-28-87	...
1	170	12-28-87	...
1	171	12-28-87	...
1	172	12-28-87	...
1	173	12-28-87	...
1	174	12-28-87	...
1	175	12-28-87	...
1	176	12-28-87	...
1	177	12-28-87	...
1	178	12-28-87	...
1	179	12-28-87	...
1	180	12-28-87	...
1	181	12-28-87	...
1	182	12-28-87	...
1	183	12-28-87	...
1	184	12-28-87	...
1	185	12-28-87	...
1	186	12-28-87	...
1	187	12-28-87	...
1	188	12-28-87	...
1	189	12-28-87	...
1	190	12-28-87	...
1	191	12-28-87	...
1	192	12-28-87	...
1	193	12-28-87	...
1	194	12-28-87	...
1	195	12-28-87	...
1	196	12-28-87	...
1	197	12-28-87	...
1	198	12-28-87	...
1	199	12-28-87	...
1	200	12-28-87	...

NOTE: THE UNIT PREFIX DESIGNATION FOR EACH COMPONENT IDENTIFICATION IS "12" UNLESS OTHERWISE NOTED

MANUALLY OPERATED VALVE IDENTIFICATION NUMBERS ONLY UNIQUE VALVE NUMBERS APPEAR ON THIS DRAWING. SEE SEPARATE VALVE IDENTIFICATION LIST FOR EQUIVALENT DESIGN (MCR) NUMBERS.

TAG NUMBERS MODIFIED FOR DRAWING USE AS FOLLOWS:
TAG NO. 2 NSW-VI05-W APPEARS AS: NSW-VI05-W

INSTRUMENT ROOT VALVE MARK NOT SHOWN ON DRAWING. SEE VALVE IDENTIFICATION LIST DERIVED BY ADDING TO INSTRUMENT NUMBER FOR SINGLE IMPULSE/STREAM FOR DOUBLE IMPULSE/STREAM/STREAM/STREAM

DATE: 12-28-87
BY: [Signature]
APPROVED: [Signature]

FOR REVISION DESCRIPTION SEE SEPARATE REVISION RECORD FOR THIS DRAWING

INDIANA & MICHIGAN ELECTRIC CO.
DONALD C. COOK
NUCLEAR PLANT

BRIDGMAN MICHIGAN

FLOW DIAGRAM
POST-ACCIDENT LIQUID AND GAS SAMPLING
UNIT #1 & 2

DR. NO. 12-5141C-8

AMERICAN ELECTRIC POWER SERVICE CORP.

FOR REVISION ONLY

SI APERTURE CARD

Also Available On Aperture Card

(RFC-DC-12-2465)

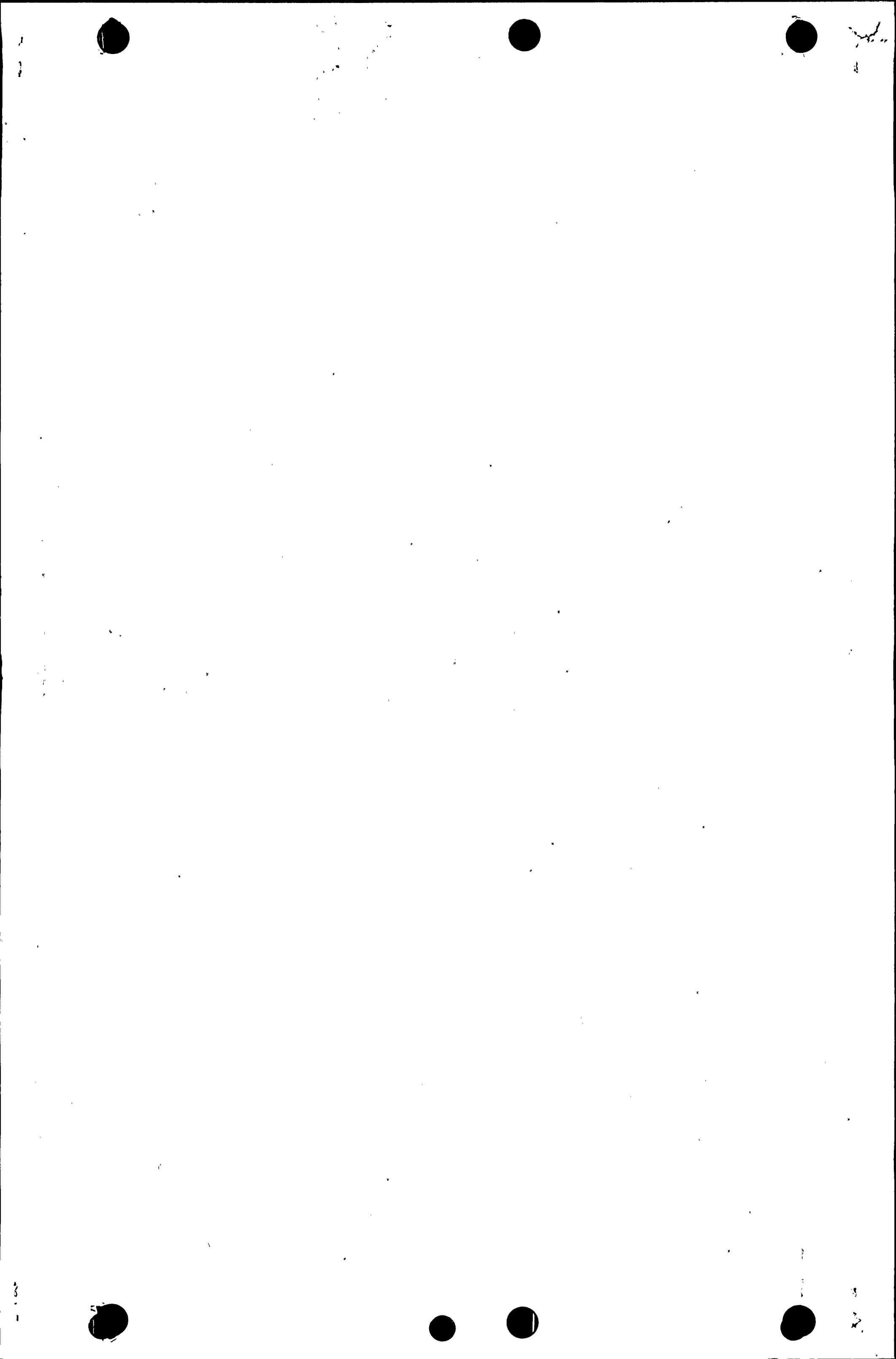

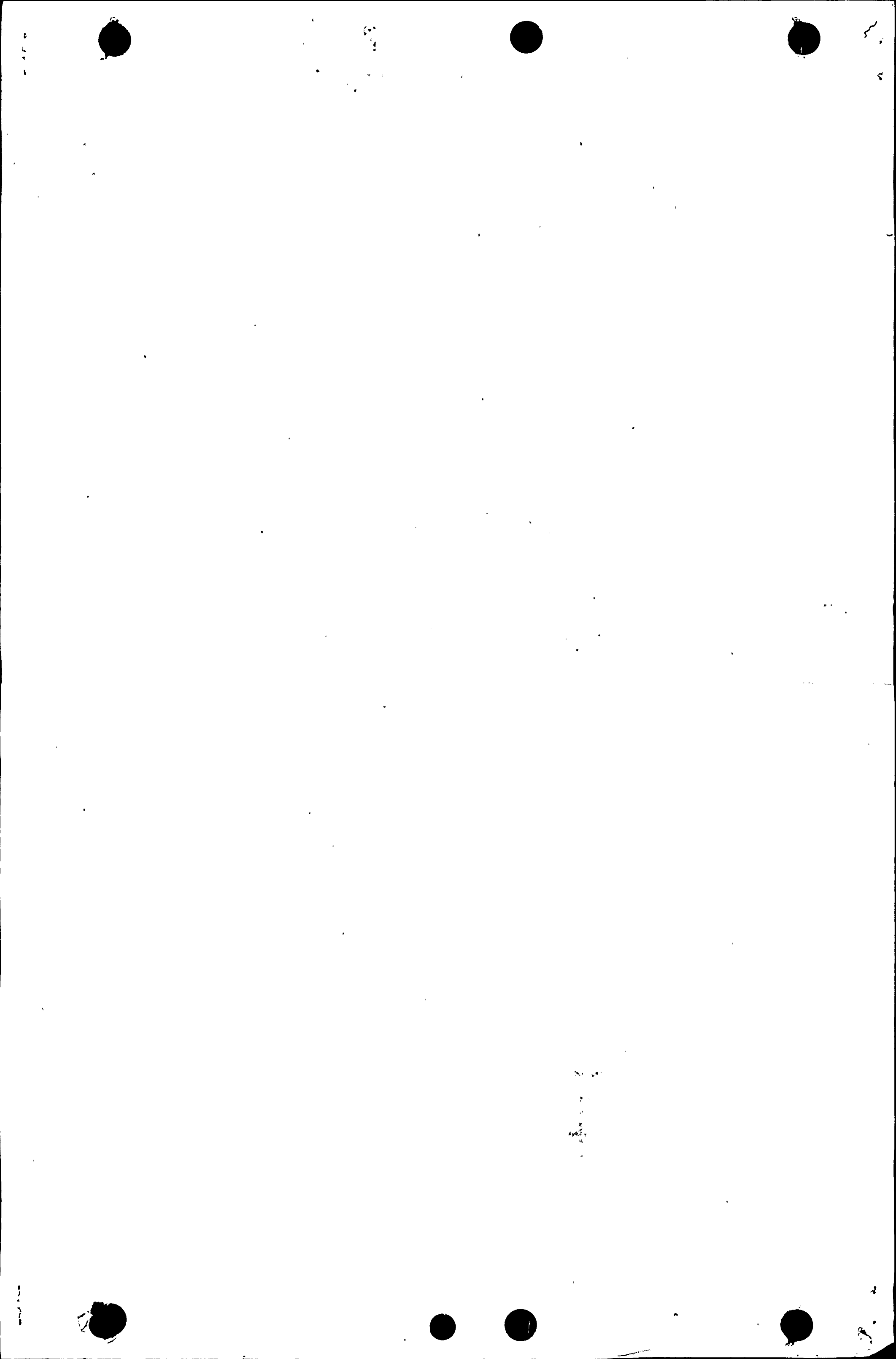

**CRITICALITY ANALYSIS OF THE
DONALD C COOK NUCLEAR PLANT FUEL RACKS**

33

November 1989

W. A. Boyd
M. W. Fecteau
J. A. Penkrot
W. P. Kovacik
J. L. Bradfute
B. W. Schmidt
R. C. Cobb
W. A. Bordogna

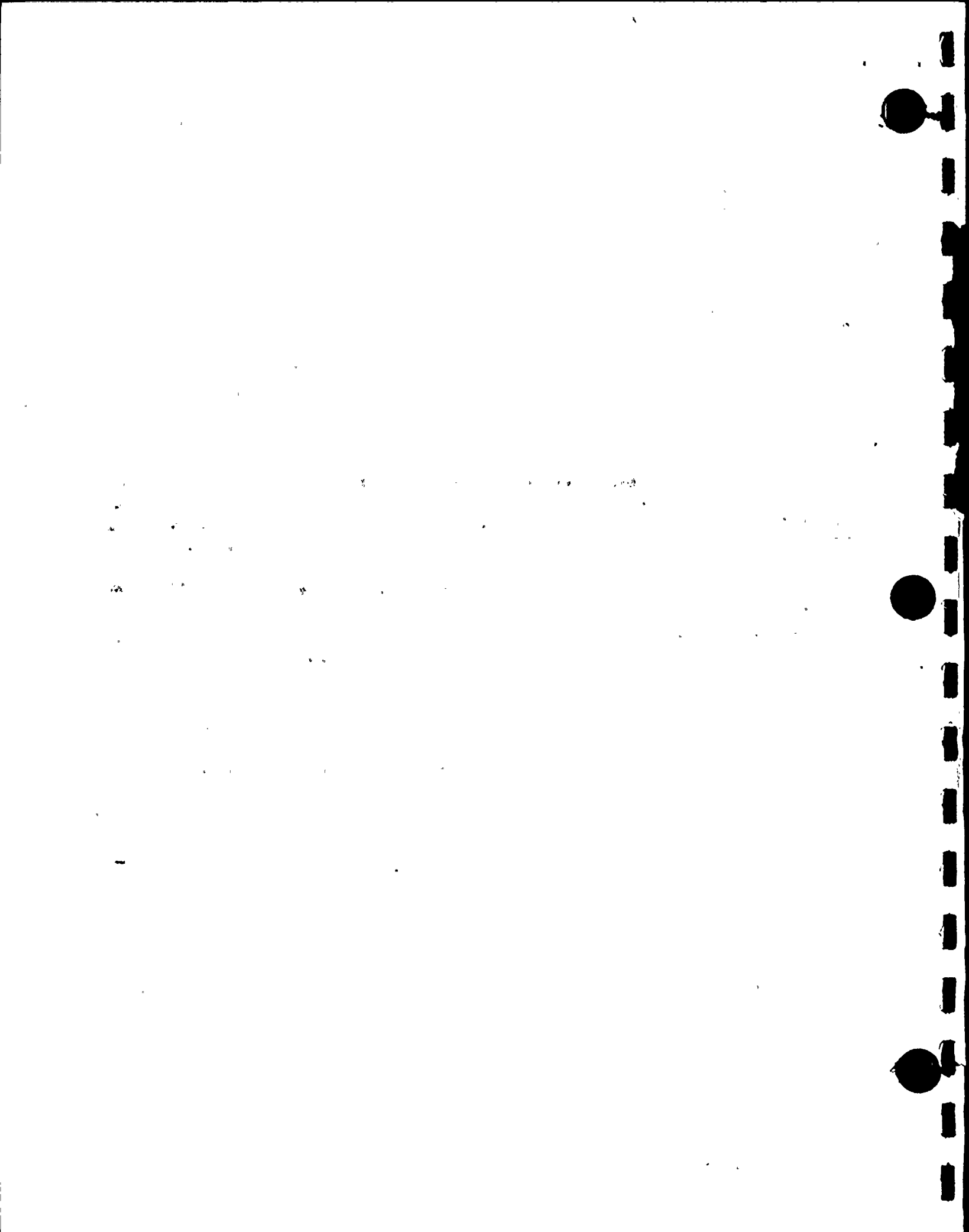
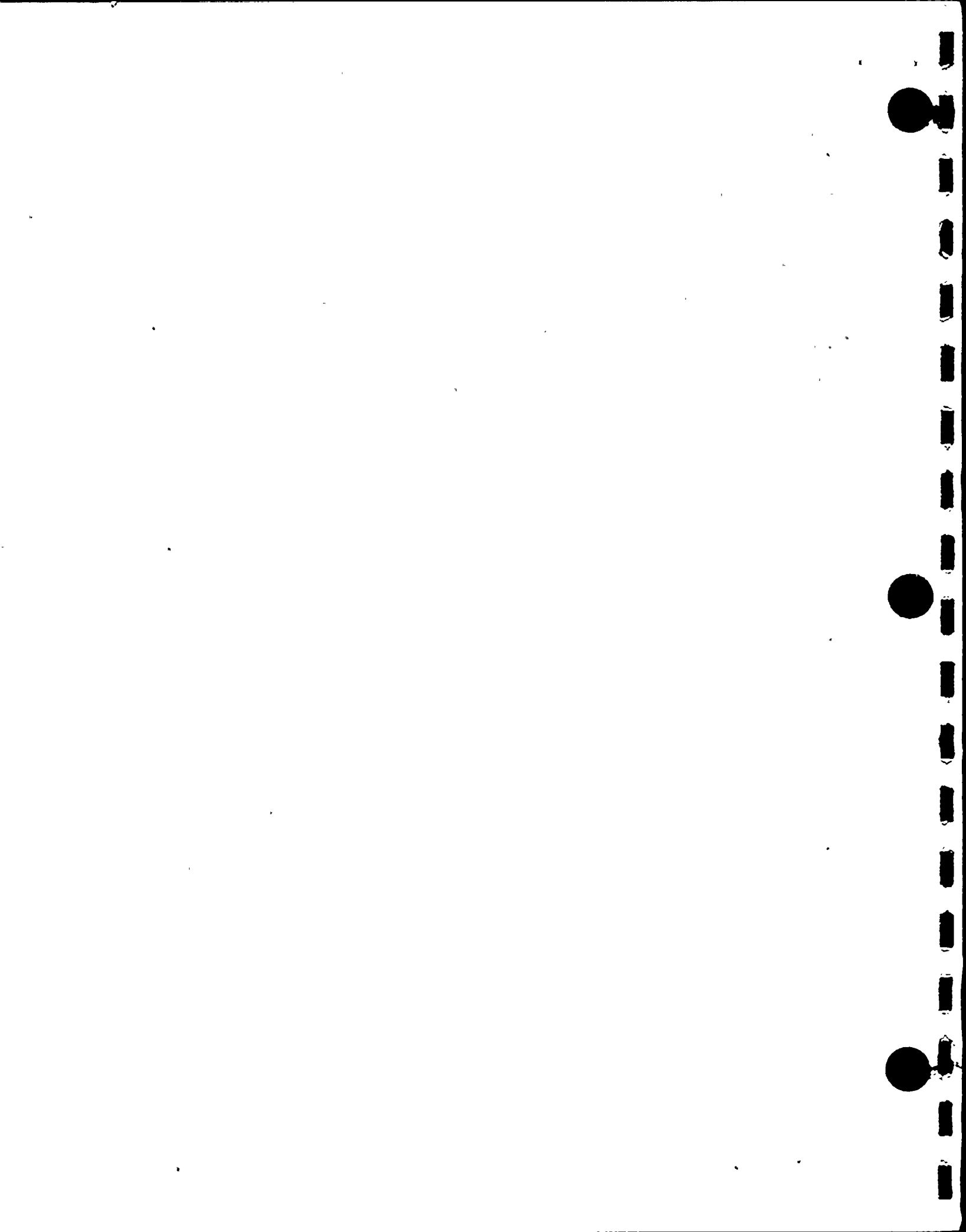

TABLE OF CONTENTS

1.0	Introduction	1
1.1	Design Description	1
1.2	Design Criteria	2
2.0	Analytical Methods	3
2.1	Criticality Calculation Methodology	3
2.2	Reactivity Equivalencing Methodology	4
3.0	Criticality Analysis of Region 1 Spent Fuel Racks	6
3.1	Reactivity Calculations	6
3.2	Postulated Accidents	8
3.3	Sensitivity Analysis	9
4.0	Criticality Analysis of Region 2 Spent Fuel Racks	10
4.1	Reactivity Equivalencing	10
4.2	Reactivity Calculations	10
4.3	Postulated Accidents	13
4.4	Sensitivity Analysis	13
5.0	Criticality Analysis of Fresh Fuel Racks	14
5.1	Full Density Moderation Analysis	15
5.2	Low Density Optimum Moderation Analysis	16
6.0	Summary of Criticality Results	18
	Bibliography	38



LIST OF TABLES

Table 1. Fuel Parameters Employed in Criticality Analysis	19
Table 2. Benchmark Critical Experiments [5,6]	20
Table 3. Comparison of PHOENIX Isotopics Predictions to Yankee Core 5 Measurements	21
Table 4. Benchmark Critical Experiments PHOENIX Comparison	22
Table 5. Data for U Metal and UO ₂ Critical Experiments	23



2025

1
2
3
4
5
6

LIST OF ILLUSTRATIONS

Figure 1.	Donald C Cook Nuclear Plant Spent Fuel Pool Storage Cell Nominal Dimensions	25
Figure 2.	Donald C Cook Nuclear Plant SFP Region 1 Three of Four Fuel Assembly Loading Schematic	26
Figure 3.	Donald C Cook Nuclear Plant Schematic for SFP Interface Boundary Between Regions 1 and 2	27
Figure 4.	Donald C Cook Nuclear Plant Fresh Fuel Rack Radial Layout . .	28
Figure 5.	Donald C Cook Nuclear Plant Fresh Fuel Rack Axial Layout . .	29
Figure 6.	Sensitivity of K_{eff} to Enrichment in the Donald C Cook Nuclear Plant SFP Region 1 Storage Area with Three of Four Loading	30
Figure 7.	Sensitivity of K_{eff} to Center-to-Center Spacing in the Donald C Cook Nuclear Plant SFP Region 1 Storage Area with Three of Four Loading	31
Figure 8.	Sensitivity of K_{eff} to B^{10} Loading in the Donald C Cook Nuclear Plant SFP Region 1 Storage Area with Three of Four Loading	32
Figure 9.	Donald C Cook Nuclear Plant SFP Region 2 Fuel Assembly Minimum Burnup vs. Initial U^{235} Enrichment Curve	33
Figure 10.	Sensitivity of K_{eff} to Enrichment in the Donald C Cook Nuclear Plant SFP Region 2 Storage Area	34
Figure 11.	Sensitivity of K_{eff} to Center-to-Center Spacing in the Donald C Cook Nuclear Plant SFP Region 2 Storage Area	35
Figure 12.	Sensitivity of K_{eff} to B^{10} Loading in the Donald C Cook Nuclear Plant SFP Region 2 Storage Area	36
Figure 13.	Sensitivity of K_{eff} to Water Density in the Donald C Cook Nuclear Plant New Fuel Storage Vault	37



1.0 INTRODUCTION

This report presents the results of the criticality analyses for the storage of Westinghouse 15x15 and 17x17 fuel assemblies in the Donald C Cook Nuclear Plant Spent Fuel Pool (SFP) storage rack and the New Fuel Storage Vault (NFSV).

The SFP rack design considered herein is an existing array of Donald C Cook Nuclear Plant SFP poisoned racks, which will be analyzed as two separate spent fuel arrays or regions. Region 1 will be analyzed for criticality using a three out of four assembly storage arrangement. The Region 1 analysis is presented in Section 3 of this report. Region 2 will be analyzed for criticality with assembly storage utilizing all locations. Region 2 will also be analyzed for burnup credit, which takes into consideration the changes in fuel and fission product inventory resulting from depletion in the reactor core. The Region 2 criticality and burnup credit analysis is presented in Section 4 of this report. Both the Region 1 and 2 analyses are based on maintaining $K_{eff} \leq 0.95$ for storage of Westinghouse 15x15 STD and OFA, and 17x17 STD, OFA and VANTAGE 5 fuel.

The NFSV rack design considered herein is an existing array of Donald C Cook Nuclear Plant NFSV unpoisoned racks which will be analyzed for criticality to show that Westinghouse 15x15 STD and OFA, and 17x17 STD, OFA and VANTAGE 5 fuel assemblies can be stored using all storage locations. The NFSV rack analysis is based on maintaining $K_{eff} \leq 0.95$ under full water density conditions and ≤ 0.98 under low water density (optimum moderation) conditions. The NFSV analysis is presented in Section 5 of this report.

The Westinghouse 15x15 and 17x17 fuel parameters relevant to these analyses are given in Table 1 on page 19.

1.1 DESIGN DESCRIPTION

The Region 1 and 2 spent fuel storage cell design is depicted schematically by Figure 1 on page 25 with nominal dimensions given on the figure. The Region 1 three out of four storage arrangement is shown in Figure 2 on page 26 and an example of the interface boundary between the Region 1 and 2 storage areas is given in Figure 3 on page 27.

The total number of SFP locations designated as Region 1 or 2 is left to the utility to determine. The boundary between the two regions can be drawn

14-00000-1

14-00000-1



anywhere within the SFP racks, but the three of four assembly storage arrangement of the Region 1 area must be carried into the Region 2 area by at least one row. Therefore, even though Region 2 is analyzed for assembly storage using all cell locations, some cells may need to be left vacant near the Region 1 to 2 boundary to accommodate the Region 1 pattern carryover by one row (refer to Figure 3 on page 27).

The fresh fuel rack storage rack radial layout is depicted in Figure 4 on page 28 and the axial layout is shown in Figure 5 on page 29.

1.2 DESIGN CRITERIA

Criticality of fuel assemblies in a fuel storage rack is prevented by the design of the rack which limits fuel assembly interaction. This is done by fixing the minimum separation between assemblies.

The design basis for preventing criticality outside the reactor is that, including uncertainties, there is a 95 percent probability at a 95 percent confidence level that the effective neutron multiplication factor, K_{eff} , of the fuel assembly array will be less than 0.95 as recommended in ANSI 57.2-1983, ANSI 57.3-1983 and in Reference 1. The 0.95 K_{eff} limit applies to both the SFP and NFSV under all conditions, except for the NFSV under low water density (optimum moderation) conditions, where the K_{eff} limit is 0.98 as recommended by NUREG-0800.



2.0 ANALYTICAL METHODS

2.1 CRITICALITY CALCULATION METHODOLOGY

The criticality calculation method and cross-section values are verified by comparison with critical experiment data for assemblies similar to those for which the racks are designed. This benchmarking data is sufficiently diverse to establish that the method bias and uncertainty will apply to rack conditions which include strong neutron absorbers, large water gaps and low moderator densities.

The design method which insures the criticality safety of fuel assemblies in the spent fuel storage rack uses the AMPX^(2, 3) system of codes for cross-section generation and KENO IV⁽⁴⁾ for reactivity determination.

The 227 energy group cross-section library that is the common starting point for all cross-sections used for the benchmarks and the storage rack is generated from ENDF/B-V⁽²⁾ data. The NITAWL⁽³⁾ program includes, in this library, the self-shielded resonance cross-sections that are appropriate for each particular geometry. The Nordheim Integral Treatment is used. Energy and spatial weighting of cross-sections is performed by the XSDRNPM⁽³⁾ program which is a one-dimensional S_n transport theory code. These multigroup cross-section sets are then used as input to KENO IV⁽⁴⁾ which is a three dimensional Monte Carlo theory program designed for reactivity calculations.

A set of 33 critical experiments has been analyzed using the above method to demonstrate its applicability to criticality analysis and to establish the method bias and uncertainty. The experiments range from water moderated, oxide fuel arrays separated by various materials (B4C, steel, water, etc) that simulate LWR fuel shipping and storage conditions⁽⁵⁾ to dry, harder spectrum uranium metal cylinder arrays with various interspersed materials⁽⁶⁾ (Plexiglas and air) that demonstrate the wide range of applicability of the method. Table 2 on page 20 summarizes these experiments.

The average K_{eff} of the benchmarks is 0.992⁽⁷⁾. The standard deviation of the bias value is 0.0008 Δk . The 95/95 one sided tolerance limit factor for 33 values is 2.19. Thus, there is a 95 percent probability with a 95 percent confidence level that the uncertainty in reactivity, due to the method, is not greater than 0.0018 Δk .

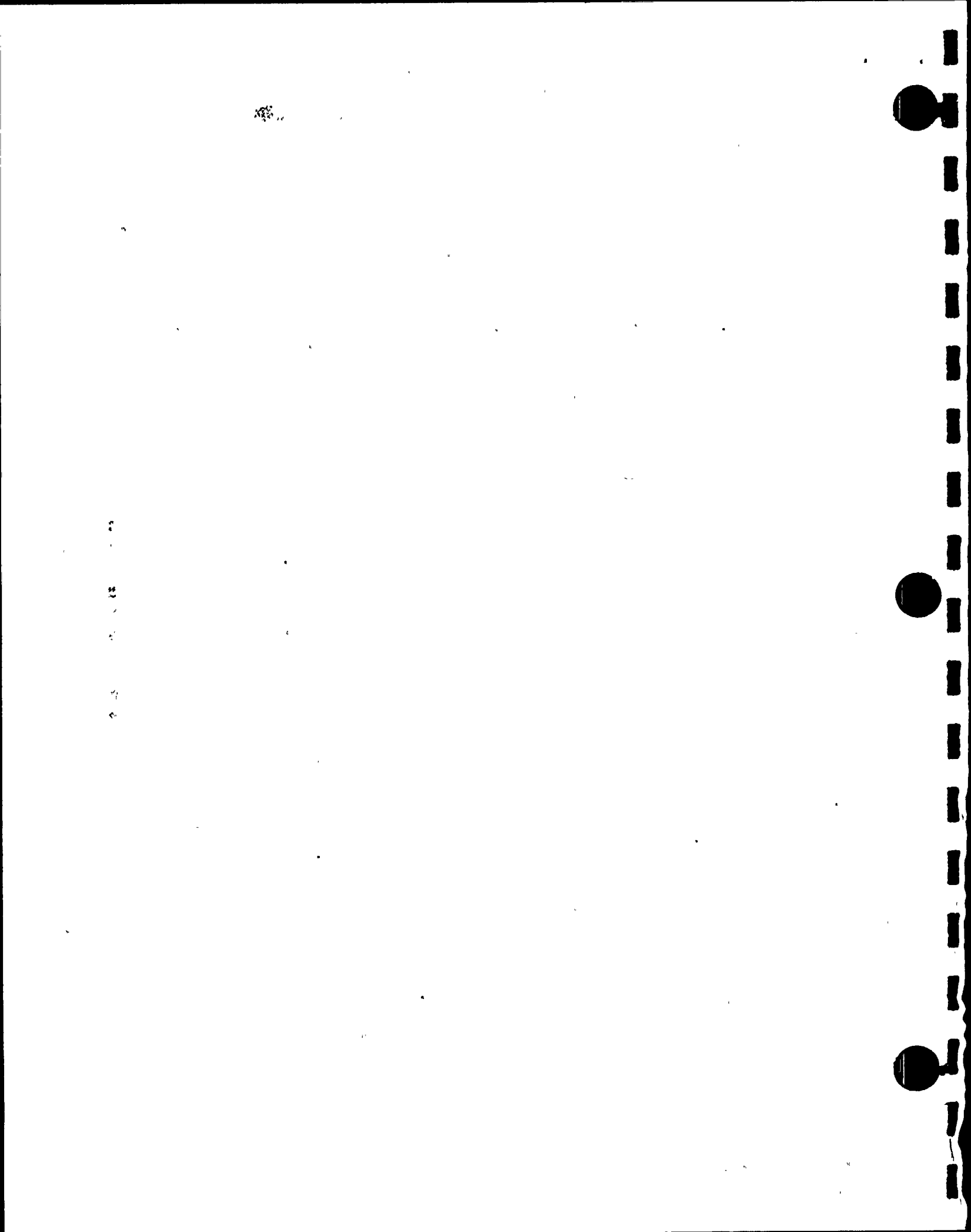

2.2 REACTIVITY EQUIVALENCING METHODOLOGY

Spent fuel storage, in the Region 2 spent fuel storage racks, is achievable by means of the concept of reactivity equivalencing. The concept of reactivity equivalencing is predicated upon the reactivity decrease associated with fuel depletion. A series of reactivity calculations are performed to generate a set of enrichment-fuel assembly discharge burnup ordered pairs which all yield the equivalent K_{eff} when the fuel is stored in the Region 2 racks.

The data points on the reactivity equivalence curve are generated with a transport theory computer code, PHOENIX⁽⁸⁾. PHOENIX is a depletable, two-dimensional, multigroup, discrete ordinates, transport theory code. A 25 energy group nuclear data library based on a modified version of the British WIMS⁽⁹⁾ library is used with PHOENIX.

A study was done to examine fuel reactivity as a function of time following discharge from the reactor. Fission product decay was accounted for using CINDER⁽¹⁰⁾. CINDER is a point-depletion computer code used to determine fission product activities. The fission products were permitted to decay for 30 years after discharge. The fuel reactivity was found to reach a maximum at approximately 100 hours after discharge. At this point in time, the major fission product poison, Xe^{135} , has nearly completely decayed away. Furthermore, the fuel reactivity was found to decrease continuously from 100 hours to 30 years following discharge. Therefore, the most reactive point in time for a fuel assembly after discharge from the reactor can be conservatively approximated by removing the Xe^{135} .

The PHOENIX code has been validated by comparisons with experiments where isotopic fuel composition has been examined following discharge from a reactor. In addition, an extensive set of benchmark critical experiments has been analyzed with PHOENIX. Comparisons between measured and predicted uranium and plutonium isotopic fuel compositions are shown in Table 3 on page 21. The measurements were made on fuel discharged from Yankee Core 5⁽¹¹⁾. The data in Table 3 on page 21 shows that the agreement between PHOENIX predictions and measured isotopic compositions is good.

The agreement between reactivities computed with PHOENIX and the results of 81 critical benchmark experiments is summarized in Table 4 on page 22. Key parameters describing each of the 81 experiments are given in Table 5 on page 23. These reactivity comparisons again show good agreement between experiment and PHOENIX calculations.

An uncertainty associated with the burnup-dependent reactivities computed with PHOENIX is accounted for in the development of the Region 2 burnup requirements. A bias which increases linearly with burnup to 0.01 Δk at 30,000 MWD/MTU is applied to the PHOENIX calculational results. This bias is considered to be very conservative since comparison between PHOENIX results and

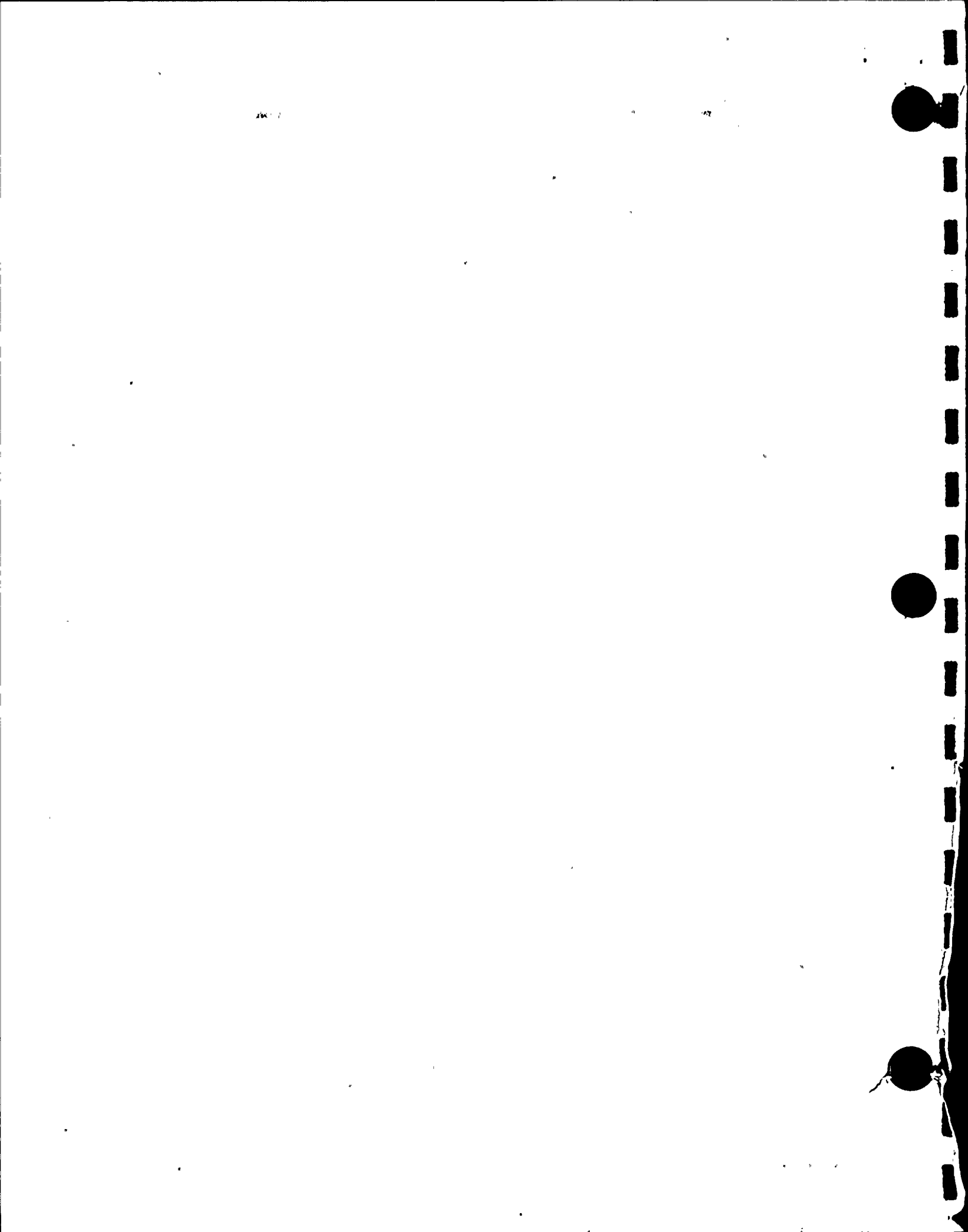

the Yankee Core experiments and 81 benchmark experiments indicates closer agreement (see Table 3 on page 21 and Table 4 on page 22). For the Donald C Cook Nuclear Plant SFP Region 2 analysis, the PHOENIX calculations for the maximum burnup of 5,550 MWD/MTU include a reactivity bias of 0.0019 Δk .

2000



3.0 CRITICALITY ANALYSIS OF REGION 1 SPENT FUEL RACKS

This section develops and describes the analytical assumptions and models employed to perform the criticality analyses for storage of spent fuel in Region 1 of the Donald C Cook Nuclear Plant SFP.

3.1 REACTIVITY CALCULATIONS

The following assumptions were used to develop the nominal case KENO model for the Region 1 SFP rack storage of fresh fuel using three out of four storage locations as shown in Figure 2 on page 26.

1. The Westinghouse 17x17 OFA fuel assembly contains the highest enrichment authorized, is at its most reactive point in life, and no credit is taken for any burnable absorber in the fuel rods or any natural enrichment axial blankets (See Table 1 on page 19 for fuel parameters). Evaluation of the Westinghouse 15x15 and 17x17 fuel assemblies shows that the 17x17 OFA assembly is the most reactive fuel type when all assemblies have the same enrichment. Therefore, only the Westinghouse 17x17 OFA fuel assembly was analyzed.
2. All fuel rods contain uranium dioxide at an enrichment of 4.95 w/o U^{235} over the finite 144 inch length of each rod. The fuel pellets are assumed to be at 96% of theoretical density, and no credit is taken for dishing or chamfering. If nominal theoretical density and pellet parameters were used, the resultant enrichment limit would be 5.06 w/o U^{235} . Therefore, the 4.95 w/o U^{235} enrichment limit can be considered a nominal enrichment limit since the conservative assumptions employed in the pellet modelling bound the standard 0.05 w/o enrichment tolerance.
3. No credit is taken for any U^{234} or U^{236} in the fuel, nor is any credit taken for the build up of fission product poison material.
4. The moderator is pure water at a temperature of 68°F. A conservative value of 1.0 gm/cm³ is used for the density of water.
5. No credit is taken for any spacer grids or spacer sleeves.



4
5
6
7
8

6. Fuel assemblies are loaded into three of every four cells in a checkerboard pattern in the storage cells as shown in Figure 2 on page 26.
7. The array is infinite in lateral extent and finite in axial extent which allows neutron leakage from only the axial direction.
8. The minimum poison material loading of 0.02 grams B¹⁰ per square centimeter is used throughout the array.

The KENO calculation for the nominal case resulted in a K_{eff} of 0.9005 with a 95 percent probability/95 percent confidence level uncertainty of ±0.0065. The nominal case result can be compared to the worst case result to determine the relative impact of applying the worst case assumptions. The nominal case is also used as the center point for the sensitivity analyses discussed in Section 3.3.

The maximum K_{eff} under normal conditions arises from consideration of mechanical and material thickness tolerances resulting from the manufacturing process in addition to asymmetric positioning of fuel assemblies within the storage cells. Westinghouse internal studies of asymmetric positioning of fuel assemblies within the storage cells have shown that symmetrically placed fuel assemblies yield equal or conservative results in rack K_{eff}. The sheet metal tolerances are considered along with construction tolerances related to the cell I.D., and cell center-to-center spacing. For the Region 1 racks this resulted in a reduction of the nominal center to center spacings to their minimum values. Thus, the "worst case" KENO model of the Region 1 storage racks contains the minimum center to center spacings with symmetrically placed fuel assemblies.

Based on the analysis described above, the following equation is used to develop the maximum K_{eff} for the Donald C Cook Nuclear Plant Region 1 spent fuel storage racks with three out of four storage:

$$K_{eff} = K_{worst} + B_{method} + B_{part} + \sqrt{[(ks)_{worst}^2 + (ks)_{method}^2]}$$

where:

- | | | |
|---------------------|---|---|
| K _{worst} | = | worst case KENO K _{eff} that includes material tolerances, and mechanical tolerances which can result in spacings between assemblies less than nominal |
| B _{method} | = | method bias determined from benchmark critical comparisons |



- B_{part} = bias to account for poison particle self-shielding. This standard term accounts for the increased neutron transmission through the poison plate due to the inherent effects of poison particle self-shielding, and has been analytically determined for poison plates similar to those used in this analysis.
- k_{Sworst} = 95/95 uncertainty in the worst case KENO K_{eff}
- $k_{Smethod}$ = 95/95 uncertainty in the method bias

Substituting calculated values in the order listed above, the result is:

$$K_{eff} = 0.9308 + 0.0083 + 0.0014 + \sqrt{[(0.0046)^2 + (0.0018)^2]} = 0.9454$$

Since K_{eff} is less than 0.95 including uncertainties at a 95/95 probability/confidence level, the acceptance criteria for criticality is met with fuel enriched to a nominal 4.95 w/o.

3.2 POSTULATED ACCIDENTS

Most accident conditions will not result in an increase in K_{eff} of the rack. Examples are the loss of cooling systems (reactivity decreases with decreasing water density) and dropping a fuel assembly on top of the rack (the rack structure pertinent for criticality is not excessively deformed and the dropped assembly has more than twelve inches of water separating it from the active fuel height of stored assemblies which precludes interaction).

However, accidents can be postulated which would increase reactivity (i.e., dropping a fuel assembly between the rack and pool wall). For these accident conditions, the double contingency principle of ANSI N16.1-1975 is applied. This states that one is not required to assume two unlikely, independent, concurrent events to ensure protection against a criticality accident. Thus, for accident conditions, the presence of soluble boron in the storage pool water can be assumed as a realistic initial condition since not assuming its presence would be a second unlikely event.

The presence of approximately 2000 ppm boron in the pool water will decrease reactivity by about 0.25 ΔK . Thus, for postulated accidents, should there be a reactivity increase, K_{eff} would be less than or equal to 0.95 due to the effect of the dissolved boron. Since the Donald C Cook Nuclear Plant, SFP will be maintained at a boron concentration of 2400 ppm, additional margin will exist to the 0.95 limit.



3.3 SENSITIVITY ANALYSIS

To show the dependence of K_{eff} on fuel and storage cells parameters as requested by the NRC⁽¹⁾, the variation of the K_{eff} with respect to the following parameters was developed using the KENO computer code:

1. Fuel enrichment, with a 0.50 w/o U^{235} delta about the nominal case enrichment.
2. Center-to-center spacing of storage cells, with a half inch delta about the nominal case center-to-center spacing.
3. Poison loading, with a 0.01 gm-B¹⁰/cm² delta about the nominal case poison loading.

Results of the sensitivity analysis for the Region 1 storage cells are shown in Figure 6 on page 30 through Figure 8 on page 32 for three of four storage.

20
21
22
23
24



4.0 CRITICALITY ANALYSIS OF REGION 2 SPENT FUEL RACKS

This section develops and describes the analytical techniques and models employed to perform the criticality analyses for storage of spent fuel in Region 2 of the Donald C Cook Nuclear Plant spent fuel pool.

4.1 REACTIVITY EQUIVALENCING

Spent fuel storage, in the Region 2 spent fuel storage racks, is achievable by means of the concept of reactivity equivalencing. The concept of reactivity equivalencing is predicated upon the reactivity decrease associated with fuel depletion. A series of reactivity calculations are performed to generate a set of enrichment-fuel assembly discharge burnup ordered pairs which all yield the equivalent K_{eff} when the fuel is stored in the Region 2 racks.

Figure 9 on page 33 shows the constant K_{eff} contour generated for the Donald C Cook Nuclear Plant Region 2 racks. Note in Figure 9 on page 33 the endpoint at 0 MWD/MTU where the enrichment is 3.95 w/o and at 5,550 MWD/MTU where the enrichment is 4.95 w/o. The interpretation of the endpoint data is as follows: the reactivity of the Region 2 racks containing fuel at 5,550 MWD/MTU burnup which had an initial nominal enrichment of 4.95 w/o is equivalent to the reactivity of the Region 2 racks containing fresh fuel having an initial nominal enrichment of 3.95 w/o. It is important to recognize that the curve in Figure 9 on page 33 is based on a constant rack reactivity for that region and not on a constant fuel assembly reactivity.

4.2 REACTIVITY CALCULATIONS

The maximum K_{eff} for storage of spent fuel in Region 2 is determined using the methods described in Section 2. Figure 9 on page 33 represents combinations of fuel enrichment and discharge burnup yielding the same rack multiplication factor (K_{eff}) as the enrichment of 3.95 w/o U^{235} at zero burnup. This curve was obtained by first calculating the equivalent reactivity points using PHOENIX and then normalizing the points to the KENO calculation for fresh fuel with a nominal enrichment of 3.95 w/o U^{235} .



The following assumptions were used to develop the nominal case KENO model for the Region 2 storage of spent fuel:

1. The Westinghouse 17x17 OFA fuel assembly contains the highest enrichment authorized, is at its most reactive point in life, and no credit is taken for any burnable absorber in the fuel rods or any natural enrichment axial blankets (See Table 1 on page 19 for fuel parameters). Evaluation of the Westinghouse 15x15 and 17x17 fuel assemblies shows that the 17x17 OFA assembly is the most reactive fuel type when all assemblies have the same enrichment. Therefore, only the Westinghouse 17x17 OFA fuel assembly was analyzed.
2. All fuel rods contain uranium dioxide at an enrichment of 3.95 w/o U^{235} over the finite 144 inch length of each rod. The fuel pellets are assumed to be at 96% of theoretical density, and no credit is taken for dishing or chamfering. If nominal theoretical density and pellet parameters were used, the resultant enrichment limit would be 4.04 w/o U^{235} . Therefore, the 3.95 w/o U^{235} enrichment limit can be considered a nominal enrichment limit since the conservative assumptions employed in the pellet modelling bound the standard 0.05 w/o enrichment tolerance.
3. No credit is taken for any U^{234} or U^{236} in the fuel, nor is any credit taken for the build up of fission product poison material.
4. The moderator is pure water at a temperature of 68°F. A conservative value of 1.0 gm/cm³ is used for the density of water.
5. No credit is taken for any spacer grids or spacer sleeves.
6. Fuel assemblies are loaded into three of every four cells in a checkerboard pattern in the storage cells as shown in Figure 2 on page 26.
7. The array is infinite in lateral extent and finite in axial extent which allows neutron leakage from only the axial direction.
8. The minimum poison material loading of 0.02 grams B^{10} per square centimeter is used throughout the array.

The KENO calculation for the nominal case resulted in a K_{eff} of 0.9141 with a 95 percent probability/95 percent confidence level uncertainty of ± 0.0049 . The nominal case result can be compared to the worst case result to determine the relative impact of applying the worst case assumptions. The nominal case is also used as the center point for the sensitivity analyses discussed in Section 4.3.

The maximum K_{eff} under normal conditions was determined with a "worst case" KENO model, in the same manner as for the Region 1 storage racks (see Section 3). For the Region 2 racks, the cell center to center spacings are reduced from the nominal value to their minimum value. Thus, the "worst case" KENO model

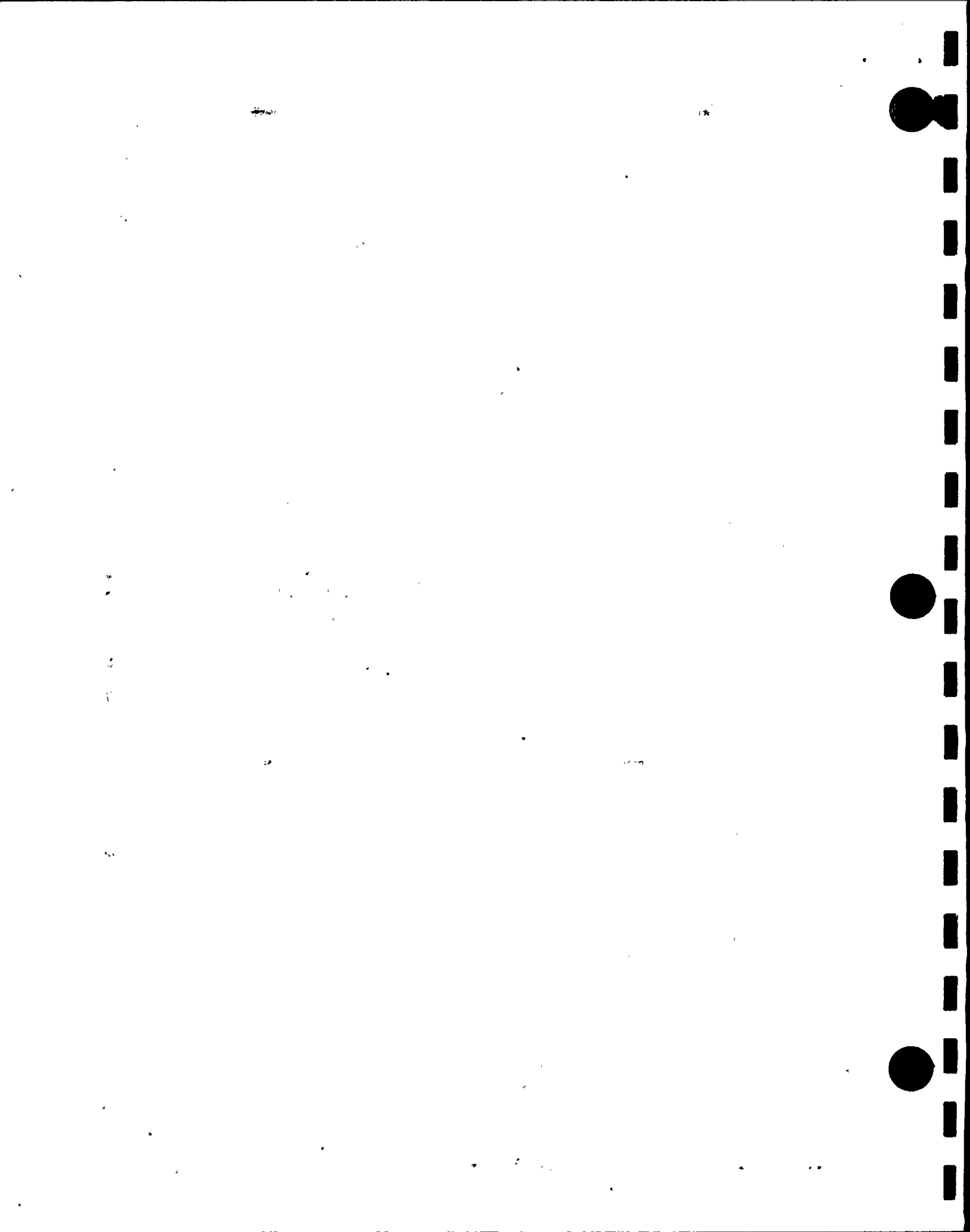

of the Region 2 storage racks contains minimum cell center to center spacings with symmetrically placed fuel assemblies. The uncertainty associated with the reactivity equivalence methodology was included in the development of the burnup requirements. This uncertainty was discussed in Section 2.2.

Based on the analysis described above, the following equation is used to develop the maximum K_{eff} for the storage of spent fuel in the Donald C Cook Nuclear Plant Region 2 spent fuel storage racks:

$$K_{eff} = K_{worst} + B_{method} + B_{part} + \sqrt{[(ks)_{worst}^2 + (ks)_{method}^2]}$$

where:

- K_{worst} = worst case KENO K_{eff} that includes material tolerances, and mechanical tolerances which can result in spacings between assemblies less than nominal
- B_{method} = method bias determined from benchmark critical comparisons
- B_{part} = bias to account for poison particle self-shielding. This standard term accounts for the increased neutron transmission through the poison plate due to the inherent effects of poison particle self-shielding, and has been analytically determined for poison plates similar to those used in this analysis.
- ks_{worst} = 95/95 uncertainty in the worst case KENO K_{eff}
- ks_{method} = 95/95 uncertainty in the method bias

Substituting calculated values in the order listed above, the result is:

$$K_{eff} = 0.9327 + 0.0083 + 0.0014 + \sqrt{[(0.0045)^2 + (0.0018)^2]} = 0.9472$$

The maximum K_{eff} for Region 2 for this configuration is less than 0.95, including all uncertainties at a 95/95 probability/confidence level. Therefore, the acceptance criteria for criticality are met for storage of spent fuel at an equivalent fresh fuel nominal enrichment of 3.95 w/o U^{235} .



4.3 POSTULATED ACCIDENTS

Most accident conditions will not result in an increase in K_{eff} of the rack. Examples are the loss of cooling systems (reactivity decreases with decreasing water density) and dropping a fuel assembly on top of the rack (the rack structure pertinent for criticality is not excessively deformed and the dropped assembly has more than twelve inches of water separating it from the active fuel height of stored assemblies which precludes interaction).

However, accidents can be postulated which would increase reactivity (i.e., misloading an assembly with a burnup and enrichment combination outside of the acceptable area in Figure 9 on page 33, or dropping a fuel assembly between the rack and pool wall). For these accident conditions, the double contingency principle of ANSI N16.1-1975 is applied. This states that one is not required to assume two unlikely, independent, concurrent events to ensure protection against a criticality accident. Thus, for accident conditions, the presence of soluble boron in the storage pool water can be assumed as a realistic initial condition since not assuming its presence would be a second unlikely event.

The presence of approximately 2000 ppm boron in the pool water will decrease reactivity by about $0.25 \Delta K$. Thus, for postulated accidents, should there be a reactivity increase, K_{eff} would be less than or equal to 0.95 due to the effect of the dissolved boron. Since the Donald C Cook Nuclear Plant SFP will be maintained at a boron concentration of 2400 ppm, additional margin will exist to the 0.95 limit.

4.4 SENSITIVITY ANALYSIS

To show the dependence of K_{eff} on fuel and storage cells parameters as requested by the NRC⁽¹⁾, the variation of the K_{eff} with respect to the following parameters was developed using the PHOENIX computer code:

1. Fuel enrichment, with a 0.50 w/o U^{235} delta about the nominal case enrichment.
2. Center-to-center spacing of storage cells, with a half inch delta about the nominal case center-to-center spacing.
3. Poison loading, with a 0.01 gm-B¹⁰/cm² delta about the nominal case poison loading.

Results of the sensitivity analysis for the Region 2 storage cells are shown in Figure 10 on page 34 through Figure 12 on page 36 for spent fuel occupying every cell in the Region 2 fuel racks.

2 4 8



5.0 CRITICALITY ANALYSIS OF FRESH FUEL RACKS

This section describes the analytical techniques and models employed to perform the criticality analysis for storage of fresh fuel in the Donald C Cook Nuclear Plant New Fuel Storage Vault (NFSV).

Since the fresh fuel racks are maintained in a dry condition, the criticality analysis will show that the rack K_{eff} is less than 0.95 for the full water density condition and less than 0.98 for the low water density (optimum moderation) conditions. The criticality methodology employed in this analysis is discussed in Section 2 of this report.

The following assumptions were used to develop the nominal case KENO model for the storage of fresh fuel in the Donald C Cook Nuclear Plant NFSV under full density and low density optimum moderation conditions:

1. The fuel assembly contains the highest enrichment authorized, is at its most reactive point in life, and no credit is taken for any burnable poison in the fuel rods or any natural enrichment axial blankets.
2. All fuel rods contain uranium dioxide at an enrichment of 4.55 w/o U^{235} over the infinite length of each rod. The fuel pellets are assumed to be at 96% of theoretical density, and no credit is taken for dishing or chamfering. If nominal theoretical density and pellet parameters were used, the resultant enrichment limit would be 4.65 w/o U^{235} . Therefore, the 4.55 w/o U^{235} enrichment limit can be considered a nominal enrichment limit since the conservative assumptions employed in the pellet modelling bound the standard 0.05 w/o enrichment tolerance.
3. No credit is taken for any U^{234} or U^{236} in the fuel, nor is any credit taken for the build up of fission product poison material.
4. No credit is taken for any spacer grids or spacer sleeves.

11
12
13

14
15
16
17
18

19



5.1 FULL DENSITY MODERATION ANALYSIS

In the nominal case KENO model for the full density moderation analysis, the moderator is pure water at a temperature of 68°F. A conservative value of 1.0 gm/cm³ is used for the density of water. The fuel array is infinite in lateral and axial extent which precludes any neutron leakage from the array. This 2D single cell modelling technique is conservative, however, the overall reactivity effect of neutron leakage from the array under full moderator density conditions is small. Calculations for the Donald C Cook Nuclear Plant NFSV array show total leakage effects to be worth only 0.005 ΔK. Fuel rack calculations have shown that the Westinghouse 17x17 OFA fuel assemblies are more reactive than the other fuel types when all fuel assemblies have the same U²³⁵ enrichment. Thus, only the Westinghouse 17x17 OFA fuel assembly was analyzed.

The maximum K_{eff} under normal conditions arises from consideration of mechanical and material thickness tolerances resulting from the manufacturing process in addition to asymmetric positioning of fuel assemblies within the storage cells. Studies of asymmetric positioning of fuel assemblies within the storage cells has shown that symmetrically placed fuel assemblies yield conservative results in rack K_{eff}. Since the Donald C Cook Nuclear Plant NFSV rack structure consists of part length angle irons, all of the structural steel was conservatively left out of the model. Thus, the most conservative, or "worst case", KENO model of the fresh fuel storage racks contains no structural steel with symmetrically placed fuel assemblies.

Based on the analysis described above, the following equation is used to develop the maximum K_{eff} for the Donald C Cook Nuclear Plant New Fuel Storage Vault:

$$K_{eff} = K_{worst} + B_{method} + \sqrt{[(ks)_{worst}^2 + (ks)_{method}^2]}$$

where:

- | | | |
|---------------------|---|---|
| K _{worst} | = | worst case KENO K _{eff} that includes material tolerances, and mechanical tolerances which can result in spacings between assemblies less than nominal |
| B _{method} | = | method bias determined from benchmark critical comparisons |
| ks _{worst} | = | 95/95 uncertainty in the worst case KENO K _{eff} |

4
2
4
4



$$k_{\text{Smethod}} = 95/95 \text{ uncertainty in the method bias}$$

Substituting calculated values in the order listed above, the result is:

$$K_{\text{eff}} = 0.9324 + 0.0083 + \sqrt{[(0.0086)^2 + (0.0018)^2]} = 0.9495$$

Since K_{eff} is less than 0.95 including uncertainties at a 95/95 probability confidence level, the acceptance criteria for criticality is met.

5.2 LOW DENSITY OPTIMUM MODERATION ANALYSIS

In the low density optimum moderation analysis, the fuel array is finite in the radial and axial extent. The nominal model described above is used in KENO except that the concrete walls and floor are explicitly modelled as shown in Figure 4 on page 28 and Figure 5 on page 29. The Westinghouse 17x17 STD fuel assembly was analyzed in the model (See Table 1 on page 19 for fuel parameters). Calculations have shown that the 17x17 STD fuel assembly is more reactive than other fuel assemblies under low moderator density conditions.

Analysis of the Donald C Cook Nuclear Plant racks has shown that the maximum rack K_{eff} under low density moderation conditions occurs at 0.045 gm/cm³ water density. The KENO calculation of the Donald C Cook Nuclear Plant NFSV at 0.045 gm/cm³ water density resulted in a peak K_{eff} of 0.8817 with a 95 percent probability and 95 percent confidence level uncertainty of ± 0.0072 . Figure 13 on page 37 shows the NFSV reactivity as a function of the water density.

Based on the analysis described above, the following equation is used to develop the maximum K_{eff} for the Donald C Cook Nuclear Plant fresh fuel storage racks under low water density optimum moderation conditions:

$$K_{\text{eff}} = K_{\text{base}} + B_{\text{method}} + \sqrt{[(k_{\text{S}})_{\text{base}}^2 + (k_{\text{S}})_{\text{method}}^2]}$$

where:

- K_{base} = maximum KENO K_{eff} with low density optimum moderation
- B_{method} = method bias determined from benchmark critical comparisons
- k_{Sbase} = 95/95 uncertainty in the base case KENO K_{eff}



$k_{\text{method}} = 95/95$ uncertainty in the method bias

Substituting calculated values in the order listed above, the result is:

$$K_{\text{eff}} = 0.8817 + 0.0083 + \sqrt{[(0.0072)^2 + (0.0018)^2]} = 0.8974$$

Since K_{eff} is less than 0.98 including uncertainties at a 95/95 probability/confidence level, the acceptance criteria for criticality is met.



6.0 SUMMARY OF CRITICALITY RESULTS

The acceptance criteria for criticality requires the effective neutron multiplication factor, K_{eff} , to be less than or equal to 0.95, including uncertainties, under all conditions for the storage of fuel assemblies in the Spent Fuel Pool (SFP). For the storage of fuel assemblies in the New Fuel Storage Vault (NFSV), the K_{eff} must be less than or equal to 0.95, including uncertainties, under flooded conditions, and less than or equal to 0.98, including uncertainties, under optimum moderation conditions.

This report shows that the acceptance criteria for criticality is met for the Donald C Cook Nuclear Plant Spent Fuel Pool (SFP) and New Fuel Storage Vault (NFSV) for the the storage of Westinghouse 15x15 and 17x17 STD, OFA and VANTAGE 5 fuel assemblies with the following nominal enrichment limits:

SFP Region 1	≤	4.95 w/o U^{235}
SFP Region 2	≤	4.95 w/o U^{235} , with burnup restrictions given by Figure 9 on page 33
NFSV	≤	4.55 w/o U^{235}

The analytical methods employed herein conform with ANSI N18.2-1973, "Nuclear Safety Criteria for the Design of Stationary Pressurized Water Reactor Plants," Section 5.7, Fuel Handling System; ANSI 57.2-1983, "Design Objectives for LWR Spent Fuel Storage Facilities at Nuclear Power Stations," Section 6.4.2; ANSI N16.9-1975, "Validation of Computational Methods for Nuclear Criticality Safety"; NRC Standard Review Plan, Section 9.1.2, "Spent Fuel Storage"; and ANSI 57.3-1983, "Design Requirements for New Fuel Storage Facilities at Light Water Reactor Plants."

Table 1. Fuel Parameters Employed in Criticality Analysis

Parameter	W 15x15 STD & OFA	W 17x17 OFA & V5	W 17x17. STD
Number of Fuel Rods per Assembly	204	264	264
Rod Zirc-4 Clad O.D. (inch)	0.422	0.360	0.374
Clad Thickness (inch)	0.0243	0.0225	0.0225
Fuel Pellet O.D.(inch)	0.3659	0.3088	0.3225
Fuel Pellet Density (% of Theoretical)	96	96	96
Fuel Pellet Dishing Factor	0.0	0.0	0.0
Rod Pitch (inch)	0.563	0.496	0.496
Number of Zirc-4 Guide Tubes	20	24	24
Guide Tube O.D. (inch)	0.533	0.474	0.482
Guide Tube Thickness (inch)	0.017	0.016	0.016
Number of Instrument Tubes	1	1	1
Instrument Tube O.D. (inch)	0.533	0.474	0.484
Instrument Tube Thickness (inch)	0.017	0.016	0.016



Table 2. Benchmark Critical Experiments [5,6]

General Description	Enrichment w/o U235	Reflector	Separating Material	Soluble Boron ppm	Keff
1. UO2 rod lattice	2.46	water	water	0	0.9857 +/- .0028
2. UO2 rod lattice	2.46	water	water	1037	0.9906 +/- .0018
3. UO2 rod lattice	2.46	water	water	764	0.9896 +/- .0015
4. UO2 rod lattice	2.46	water	B4C pins	0	0.9914 +/- .0025
5. UO2 rod lattice	2.46	water	B4C pins	0	0.9891 +/- .0026
6. UO2 rod lattice	2.46	water	B4C pins	0	0.9955 +/- .0020
7. UO2 rod lattice	2.46	water	B4C pins	0	0.9889 +/- .0027
8. UO2 rod lattice	2.46	water	B4C pins	0	0.9983 +/- .0025
9. UO2 rod lattice	2.46	water	water	0	0.9931 +/- .0028
10. UO2 rod lattice	2.46	water	water	143	0.9928 +/- .0025
11. UO2 rod lattice	2.46	water	stainless steel	514	0.9967 +/- .0020
12. UO2 rod lattice	2.46	water	stainless steel	217	0.9943 +/- .0019
13. UO2 rod lattice	2.46	water	borated aluminum	15	0.9892 +/- .0023
14. UO2 rod lattice	2.46	water	borated aluminum	92	0.9884 +/- .0023
15. UO2 rod lattice	2.46	water	borated aluminum	395	0.9832 +/- .0021
16. UO2 rod lattice	2.46	water	borated aluminum	121	0.9848 +/- .0024
17. UO2 rod lattice	2.46	water	borated aluminum	487	0.9895 +/- .0020
18. UO2 rod lattice	2.46	water	borated aluminum	197	0.9885 +/- .0022
19. UO2 rod lattice	2.46	water	borated aluminum	634	0.9921 +/- .0019
20. UO2 rod lattice	2.46	water	borated aluminum	320	0.9920 +/- .0020
21. UO2 rod lattice	2.46	water	borated aluminum	72	0.9939 +/- .0020
22. U metal cylinders	93.2	bare	air	0	0.9905 +/- .0020
23. U metal cylinders	93.2	bare	air	0	0.9976 +/- .0020
24. U metal cylinders	93.2	bare	air	0	0.9947 +/- .0025
25. U metal cylinders	93.2	bare	air	0	0.9928 +/- .0019
26. U metal cylinders	93.2	bare	air	0	0.9928 +/- .0026
27. U metal cylinders	93.2	bare	air	0	0.9950 +/- .0027
28. U metal cylinders	93.2	bare	plexiglass	0	0.9941 +/- .0030
29. U metal cylinders	93.2	paraffin	plexiglass	0	0.9928 +/- .0041
30. U metal cylinders	93.2	bare	plexiglass	0	0.9968 +/- .0018
31. U metal cylinders	93.2	paraffin	plexiglass	0	1.0042 +/- .0019
32. U metal cylinders	93.2	paraffin	plexiglass	0	0.9963 +/- .0030
33. U metal cylinders	93.2	paraffin	plexiglass	0	0.9919 +/- .0032



Table 3. Comparison of PHOENIX Isotopics Predictions to Yankee Core 5 Measurements

Quantity (Atom Ratio)	% Difference
U235/U	-0.67
U236/U	-0.28
U238/U	-0.03
PU239/U	+3.27
PU240/U	+3.63
PU241/U	-7.01
PU242/U	-0.20
PU239/U238	+3.24
Mass(PU/U)	+1.41
FISS-PU/TOT-PU	-0.02



Table 4. Benchmark Critical Experiments PHOENIX Comparison

Description of Experiments	Number of Experiments	PHOENIX K_{eff} Using Experiment Bucklings
UO ₂		
Al clad	14	0.9947
SS clad	19	0.9944
Borated H ₂ O	7	0.9940
Subtotal	40	0.9944
U-Metal		
Al clad	41	1.0012
TOTAL	81	0.9978

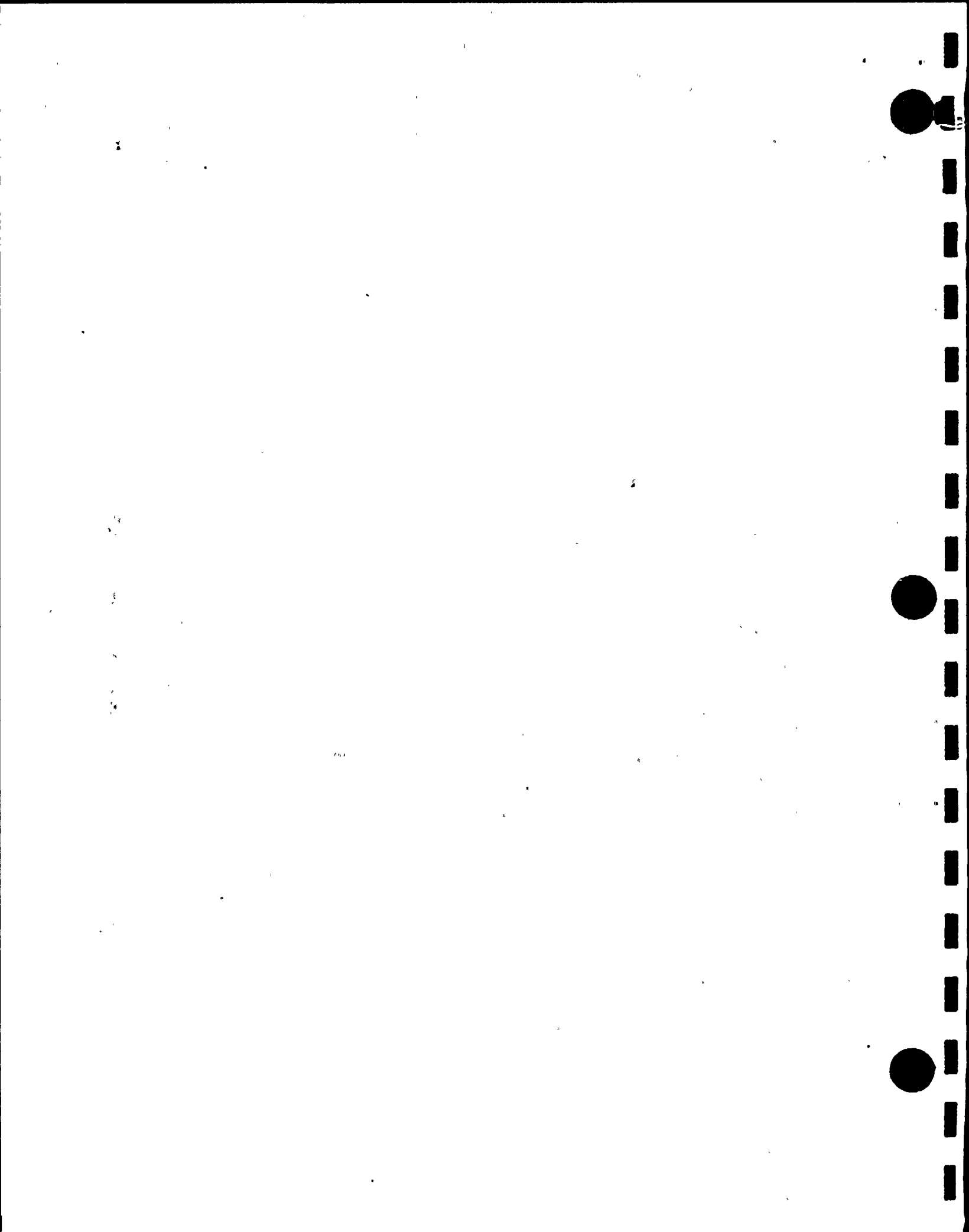

Table 5. Data for U Metal and UO₂ Critical Experiments (Part 1 of 2)

Case Number	Cell Type	A/O U-235	H ₂ O/U Ratio	Fuel Density (G/CC)	Pellet Diameter (CM)	Material Clad	Clad OD (CM)	Clad Thickness (CM)	Lattice Pitch (CM)	Boron PPM
1	Hexa	1.328	3.02	7.53	1.5265	Aluminum	1.6916	.07110	2.2050	0.0
2	Hexa	1.328	3.95	7.53	1.5265	Aluminum	1.6916	.07110	2.3590	0.0
3	Hexa	1.328	4.95	7.53	1.5265	Aluminum	1.6916	.07110	2.5120	0.0
4	Hexa	1.328	3.92	7.52	.9855	Aluminum	1.1506	.07110	1.5580	0.0
5	Hexa	1.328	4.89	7.52	.9855	Aluminum	1.1506	.07110	1.6520	0.0
6	Hexa	1.328	2.88	10.53	.9728	Aluminum	1.1506	.07110	1.5580	0.0
7	Hexa	1.328	3.58	10.53	.9728	Aluminum	1.1506	.07110	1.6520	0.0
8	Hexa	1.328	4.83	10.53	.9728	Aluminum	1.1506	.07110	1.8060	0.0
9	Square	2.734	2.18	10.18	.7620	SS-304	.8594	.04085	1.0287	0.0
10	Square	2.734	2.92	10.18	.7620	SS-304	.8594	.04085	1.1049	0.0
11	Square	2.734	3.86	10.18	.7620	SS-304	.8594	.04085	1.1938	0.0
12	Square	2.734	7.02	10.18	.7620	SS-304	.8594	.04085	1.4554	0.0
13	Square	2.734	8.49	10.18	.7620	SS-304	.8594	.04085	1.5621	0.0
14	Square	2.734	10.38	10.18	.7620	SS-304	.8594	.04085	1.6891	0.0
15	Square	2.734	2.50	10.18	.7620	SS-304	.8594	.04085	1.0617	0.0
16	Square	2.734	4.51	10.18	.7620	SS-304	.8594	.04085	1.2522	0.0
17	Square	3.745	2.50	10.27	.7544	SS-304	.8600	.04060	1.0617	0.0
18	Square	3.745	4.51	10.37	.7544	SS-304	.8600	.04060	1.2522	0.0
19	Square	3.745	4.51	10.37	.7544	SS-304	.8600	.04060	1.2522	0.0
20	Square	3.745	4.51	10.37	.7544	SS-304	.8600	.04060	1.2522	456.0
21	Square	3.745	4.51	10.37	.7544	SS-304	.8600	.04060	1.2522	709.0
22	Square	3.745	4.51	10.37	.7544	SS-304	.8600	.04060	1.2522	1260.0
23	Square	3.745	4.51	10.37	.7544	SS-304	.8600	.04060	1.2522	1334.0
24	Square	3.745	4.51	10.37	.7544	SS-304	.8600	.04060	1.2522	1477.0
25	Square	4.069	2.55	9.46	1.1278	SS-304	1.2090	.04060	1.5113	0.0
26	Square	4.069	2.55	9.46	1.1278	SS-304	1.2090	.04060	1.5113	3392.0
27	Square	4.069	2.14	9.46	1.1278	SS-304	1.2090	.04060	1.4500	0.0
28	Square	2.490	2.84	10.24	1.0297	Aluminum	1.2060	.08130	1.5113	0.0
29	Square	3.037	2.64	9.28	1.1268	SS-304	1.1701	.07163	1.5550	0.0
30	Square	3.037	8.16	9.28	1.1268	SS-304	1.2701	.07163	2.1980	0.0
31	Square	4.069	2.59	9.45	1.1268	SS-304	1.2701	.07163	1.5550	0.0
32	Square	4.069	3.53	9.45	1.1268	SS-304	1.2701	.07163	1.6840	0.0
33	Square	4.069	8.02	9.45	1.1268	SS-304	1.2701	.07163	2.1980	0.0
34	Square	4.069	9.90	9.45	1.1268	SS-304	1.2701	.07163	2.3810	0.0
35	Square	2.490	2.84	10.24	1.0297	Aluminum	1.2060	.08130	1.5113	1677.0
36	Hexa	2.096	2.06	10.38	1.5240	Aluminum	1.6916	.07112	2.1737	0.0
37	Hexa	2.096	3.09	10.38	1.5240	Aluminum	1.6916	.07112	2.4052	0.0
38	Hexa	2.096	4.12	10.38	1.5240	Aluminum	1.6916	.07112	2.6162	0.0
39	Hexa	2.096	6.14	10.38	1.5240	Aluminum	1.6916	.07112	2.9891	0.0
40	Hexa	2.096	8.20	10.38	1.5240	Aluminum	1.6916	.07112	3.3255	0.0
41	Hexa	1.307	1.01	18.90	1.5240	Aluminum	1.6916	.07112	2.1742	0.0
42	Hexa	1.307	1.51	18.90	1.5240	Aluminum	1.6916	.07112	2.4054	0.0
43	Hexa	1.307	2.02	18.90	1.5240	Aluminum	1.6916	.07112	2.6162	0.0

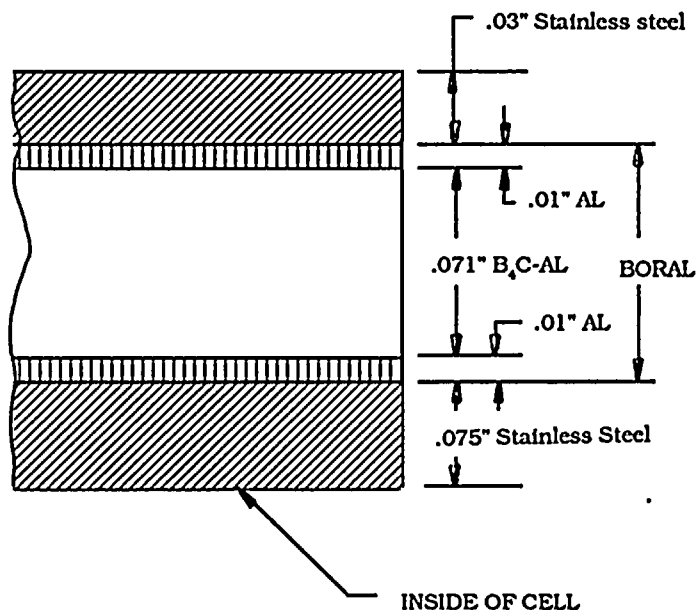
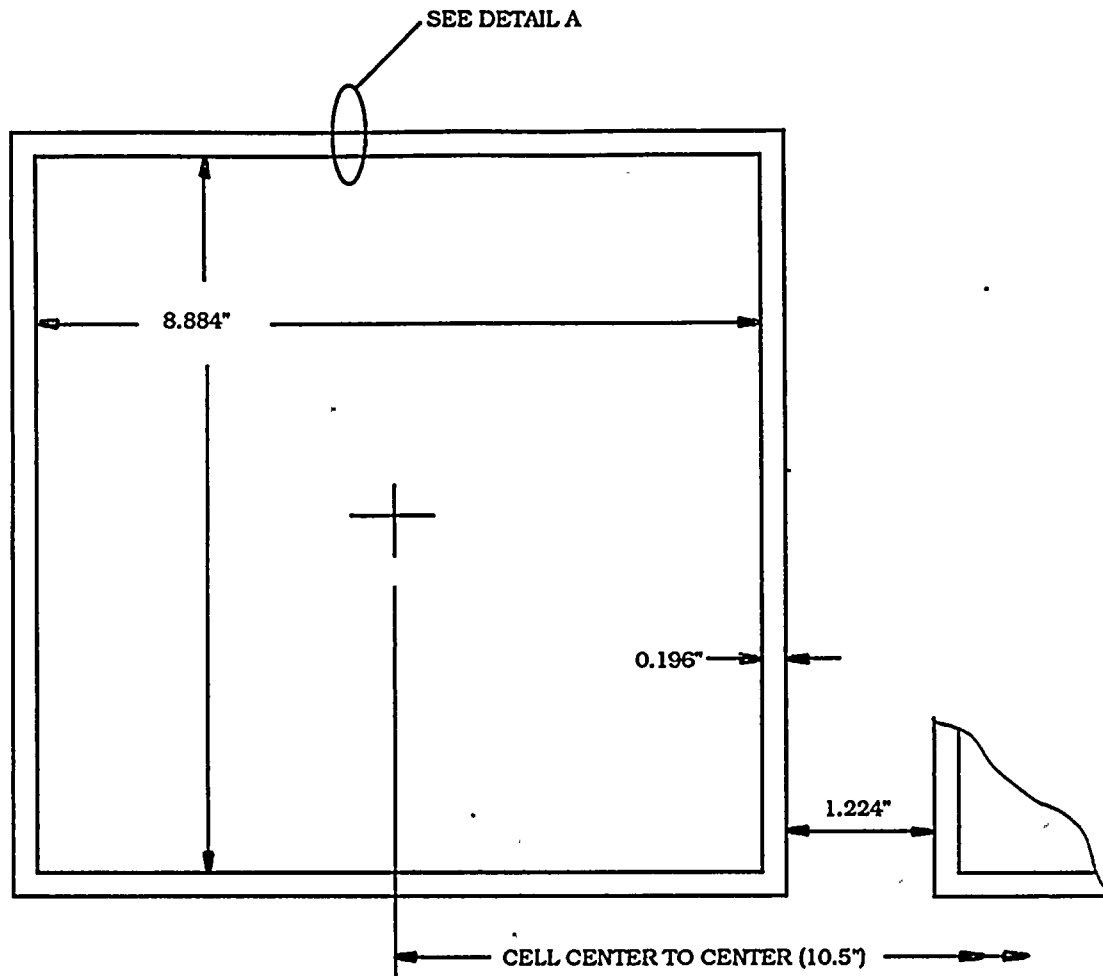

Table 5. Data for U Metal and UO₂ Critical Experiments (Part 2 of 2)

Case Number	Cell Type	A/O U-235	H ₂ O/U Ratio	Fuel Density (G/CC)	Pellet Diameter (CM)	Material Clad	Clad OD (CM)	Clad Thickness (CM)	Lattice Pitch (CM)	Boron PPM
44	Hexa	1.307	3.01	18.90	1.5240	Aluminum	1.6916	.07112	2.9896	0.0
45	Hexa	1.307	4.02	18.90	1.5240	Aluminum	1.6916	.07112	3.3249	0.0
46	Hexa	1.160	1.01	18.90	1.5240	Aluminum	1.6916	.07112	2.1742	0.0
47	Hexa	1.160	1.51	18.90	1.5240	Aluminum	1.6916	.07112	2.4054	0.0
48	Hexa	1.160	2.02	18.90	1.5240	Aluminum	1.6916	.07112	2.6162	0.0
49	Hexa	1.160	3.01	18.90	1.5240	Aluminum	1.6916	.07112	2.9896	0.0
50	Hexa	1.160	4.02	18.90	1.5240	Aluminum	1.6916	.07112	3.3249	0.0
51	Hexa	1.040	1.01	18.90	1.5240	Aluminum	1.6916	.07112	2.1742	0.0
52	Hexa	1.040	1.51	18.90	1.5240	Aluminum	1.6916	.07112	2.4054	0.0
53	Hexa	1.040	2.02	18.90	1.5240	Aluminum	1.6916	.07112	2.6162	0.0
54	Hexa	1.040	3.01	18.90	1.5240	Aluminum	1.6916	.07112	2.9896	0.0
55	Hexa	1.040	4.02	18.90	1.5240	Aluminum	1.6916	.07112	3.3249	0.0
56	Hexa	1.307	1.00	18.90	.9830	Aluminum	1.1506	.07112	1.4412	0.0
57	Hexa	1.307	1.52	18.90	.9830	Aluminum	1.1506	.07112	1.5926	0.0
58	Hexa	1.307	2.02	18.90	.9830	Aluminum	1.1506	.07112	1.7247	0.0
59	Hexa	1.307	3.02	18.90	.9830	Aluminum	1.1506	.07112	1.9609	0.0
60	Hexa	1.307	4.02	18.90	.9830	Aluminum	1.1506	.07112	2.1742	0.0
61	Hexa	1.160	1.52	18.90	.9830	Aluminum	1.1506	.07112	1.5926	0.0
62	Hexa	1.160	2.02	18.90	.9830	Aluminum	1.1506	.07112	1.7247	0.0
63	Hexa	1.160	3.02	18.90	.9830	Aluminum	1.1506	.07112	1.9609	0.0
64	Hexa	1.160	4.02	18.90	.9830	Aluminum	1.1506	.07112	2.1742	0.0
65	Hexa	1.160	1.00	18.90	.9830	Aluminum	1.1506	.07112	1.4412	0.0
66	Hexa	1.160	1.52	18.90	.9830	Aluminum	1.1506	.07112	1.5926	0.0
67	Hexa	1.160	2.02	18.90	.9830	Aluminum	1.1506	.07112	1.7247	0.0
68	Hexa	1.160	3.02	18.90	.9830	Aluminum	1.1506	.07112	1.9609	0.0
69	Hexa	1.160	4.02	18.90	.9830	Aluminum	1.1506	.07112	2.1742	0.0
70	Hexa	1.040	1.33	18.90	19.050	Aluminum	2.0574	.07620	2.8687	0.0
71	Hexa	1.040	1.58	18.90	19.050	Aluminum	2.0574	.07620	3.0086	0.0
72	Hexa	1.040	1.83	18.90	19.050	Aluminum	2.0574	.07620	3.1425	0.0
73	Hexa	1.040	2.33	18.90	19.050	Aluminum	2.0574	.07620	3.3942	0.0
74	Hexa	1.040	2.83	18.90	19.050	Aluminum	2.0574	.07620	3.6284	0.0
75	Hexa	1.040	3.83	18.90	19.050	Aluminum	2.0574	.07620	4.0566	0.0
76	Hexa	1.310	2.02	18.88	1.5240	Aluminum	1.6916	.07112	2.6160	0.0
77	Hexa	1.310	3.01	18.88	1.5240	Aluminum	1.6916	.07112	2.9900	0.0
78	Hexa	1.159	2.02	18.88	1.5240	Aluminum	1.6916	.07112	2.6160	0.0
79	Hexa	1.159	3.01	18.88	1.5240	Aluminum	1.6916	.07112	2.9900	0.0
80	Hexa	1.312	2.03	18.88	.9830	Aluminum	1.1506	.07112	1.7250	0.0
81	Hexa	1.312	3.02	18.88	.9830	Aluminum	1.1506	.07112	1.9610	0.0

11





DETAIL A

Figure 1. Donald C Cook Nuclear Plant Spent Fuel Pool Storage Cell Nominal Dimensions



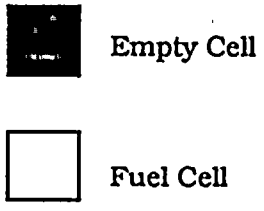
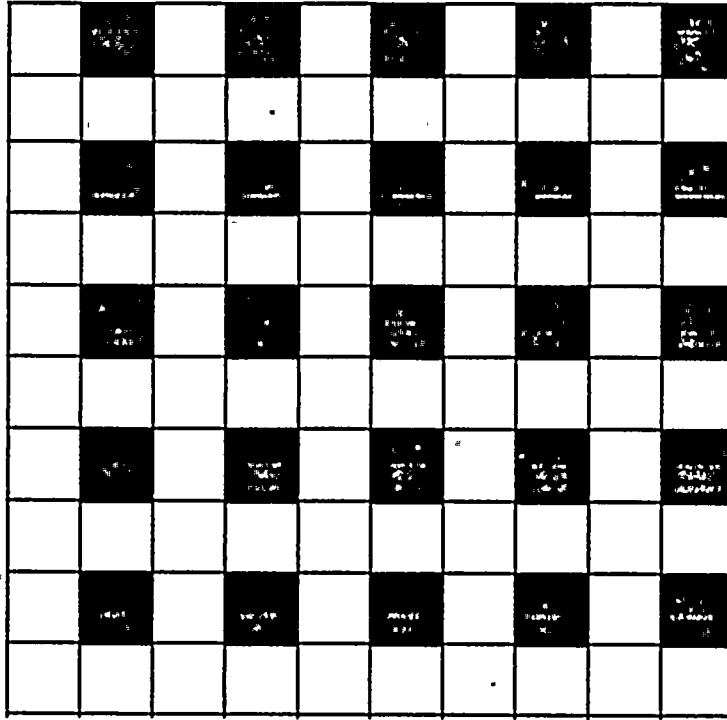
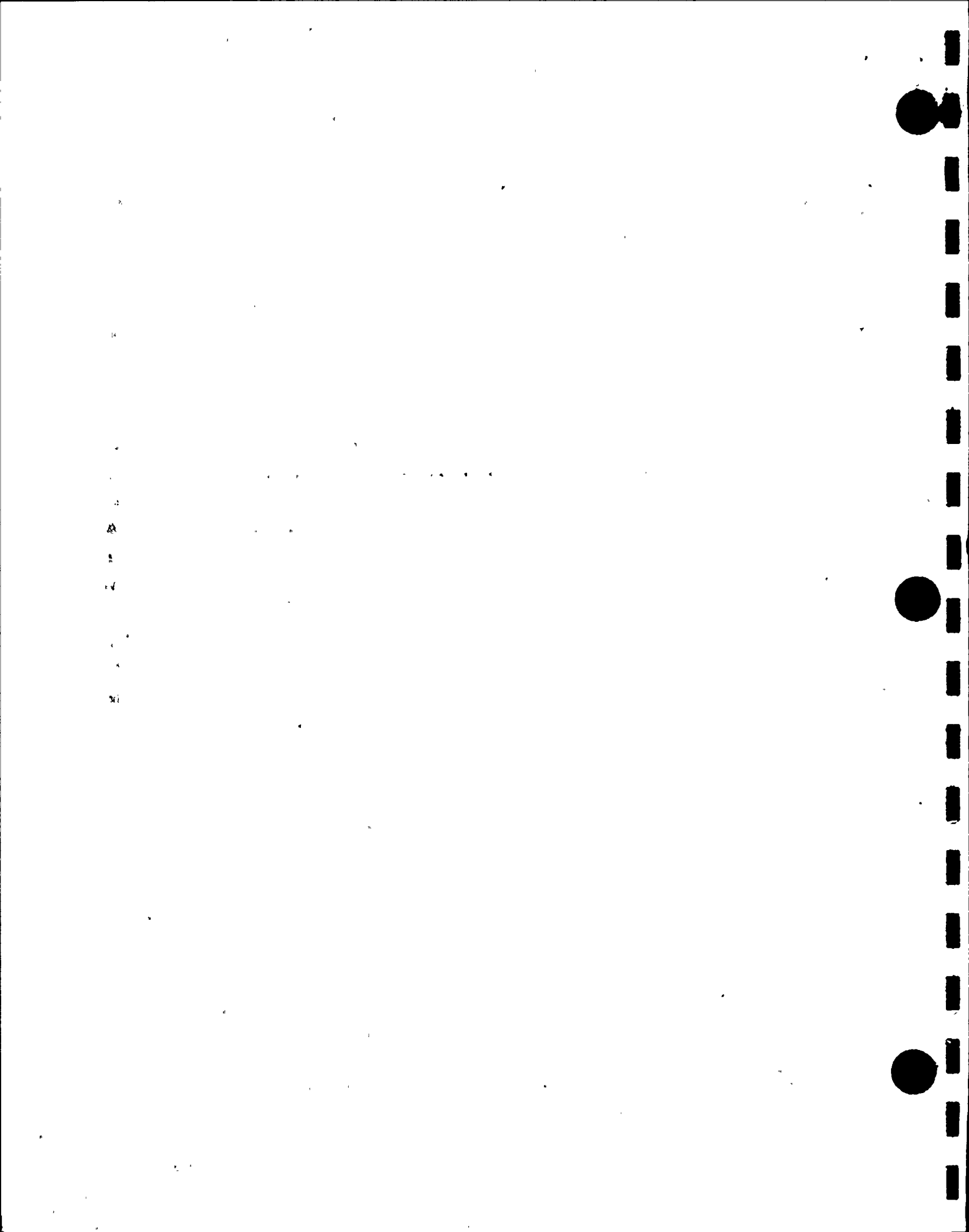

Figure 2. Donald C Cook Nuclear Plant SFP Region 1 Three of Four Fuel Assembly Loading Schematic



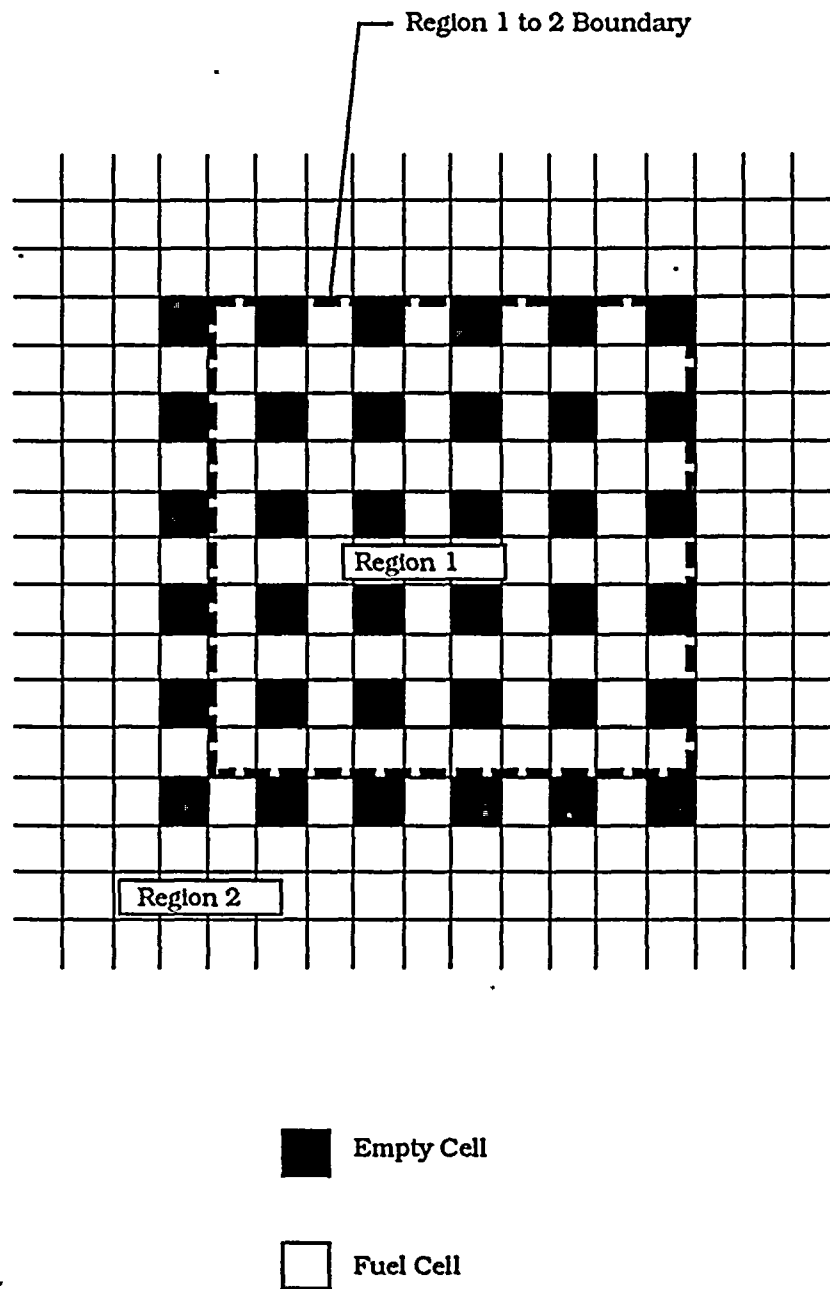

Figure 3. Donald C Cook Nuclear Plant Schematic for SFP Interface Boundary Between Regions 1 and 2



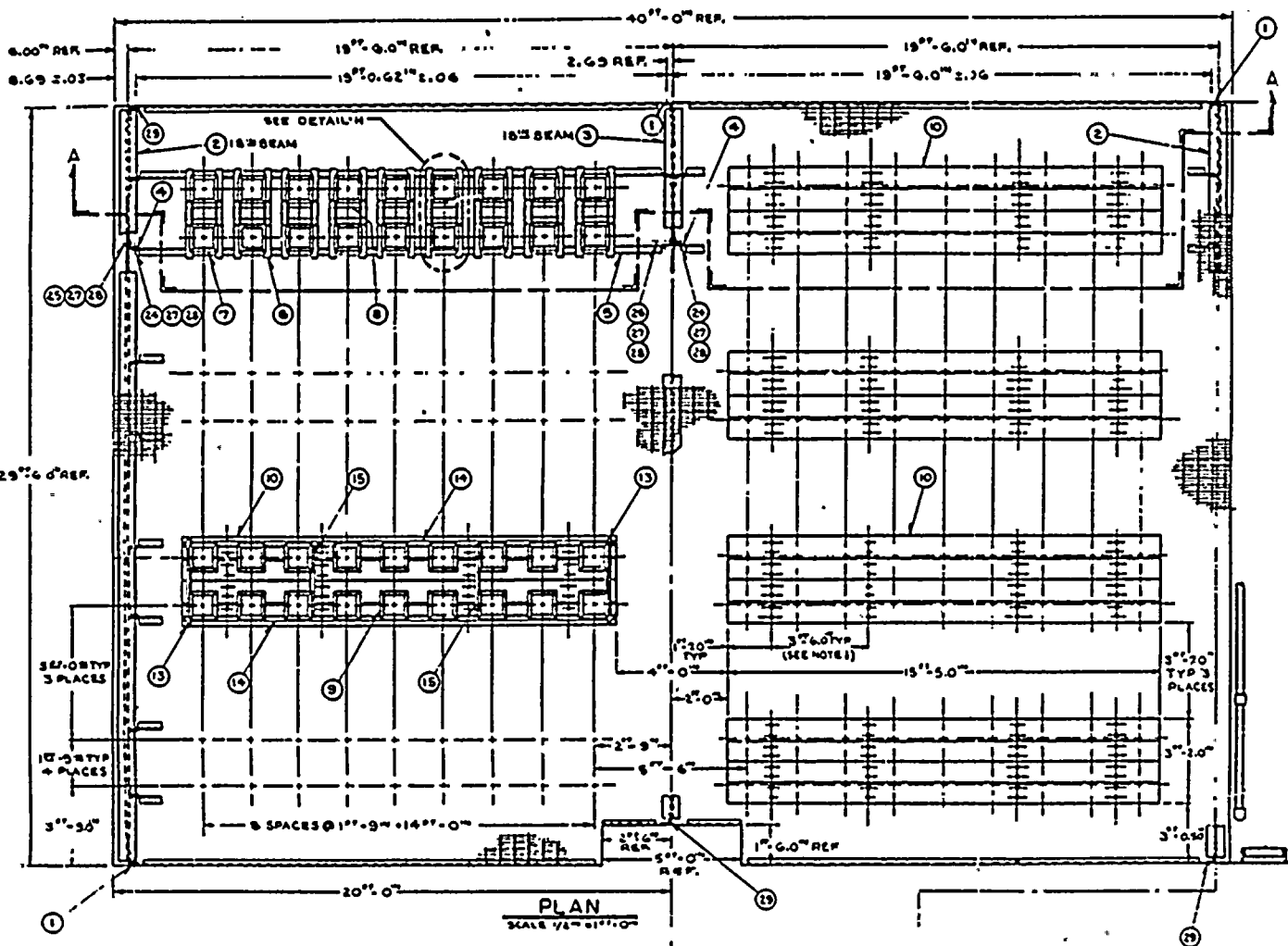

Figure 4. Donald C Cook Nuclear Plant Fresh Fuel Rack Radial Layout



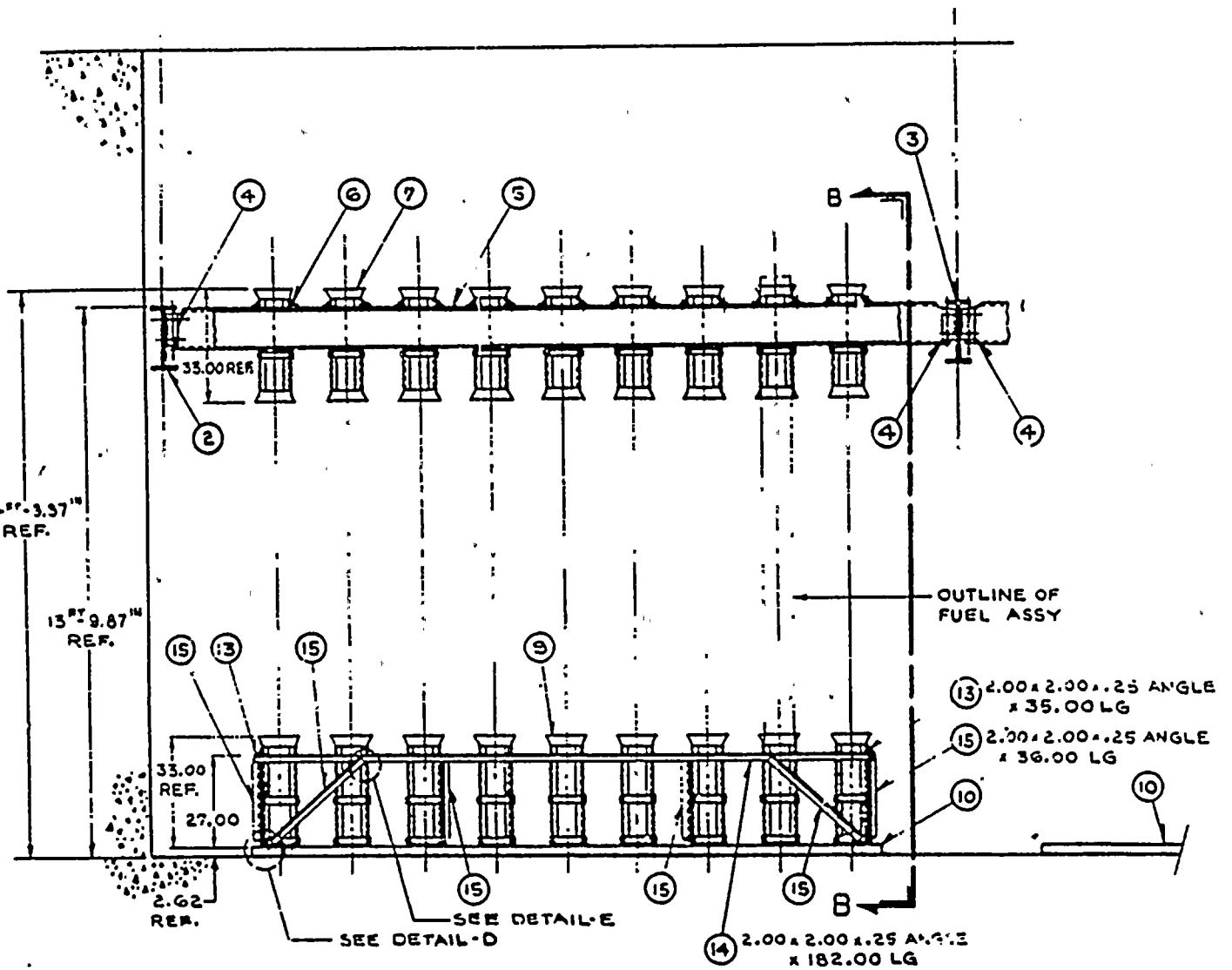
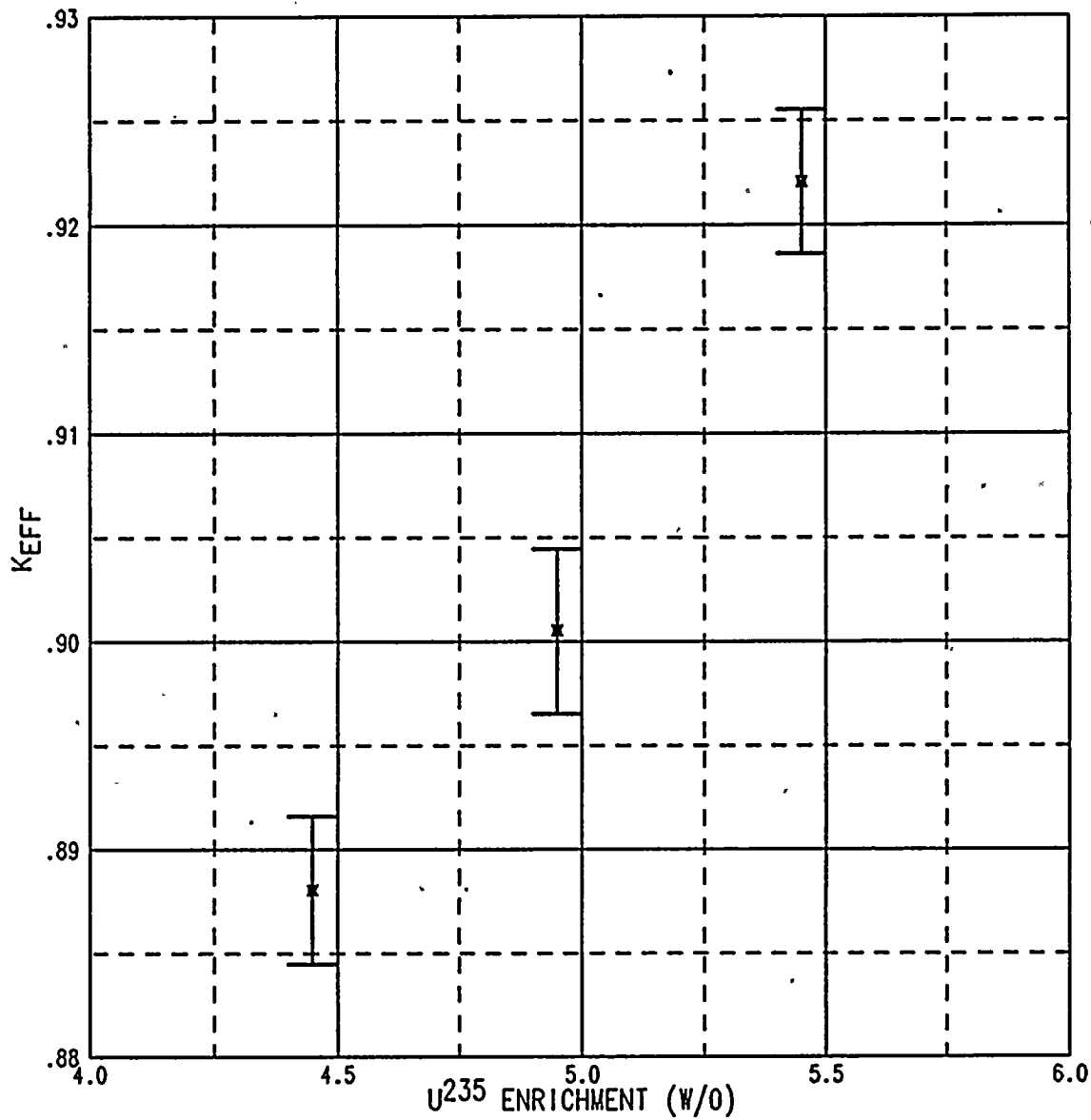

Figure 5. Donald C Cook Nuclear Plant Fresh Fuel Rack Axial Layout





BORAL HELD AT .02 GM B10/CM2
 CENTER TO CENTER HELD AT 10.5"

Figure 6. Sensitivity of K_{eff} to Enrichment in the Donald C Cook Nuclear Plant SFP Region 1 Storage Area with Three of Four Loading.



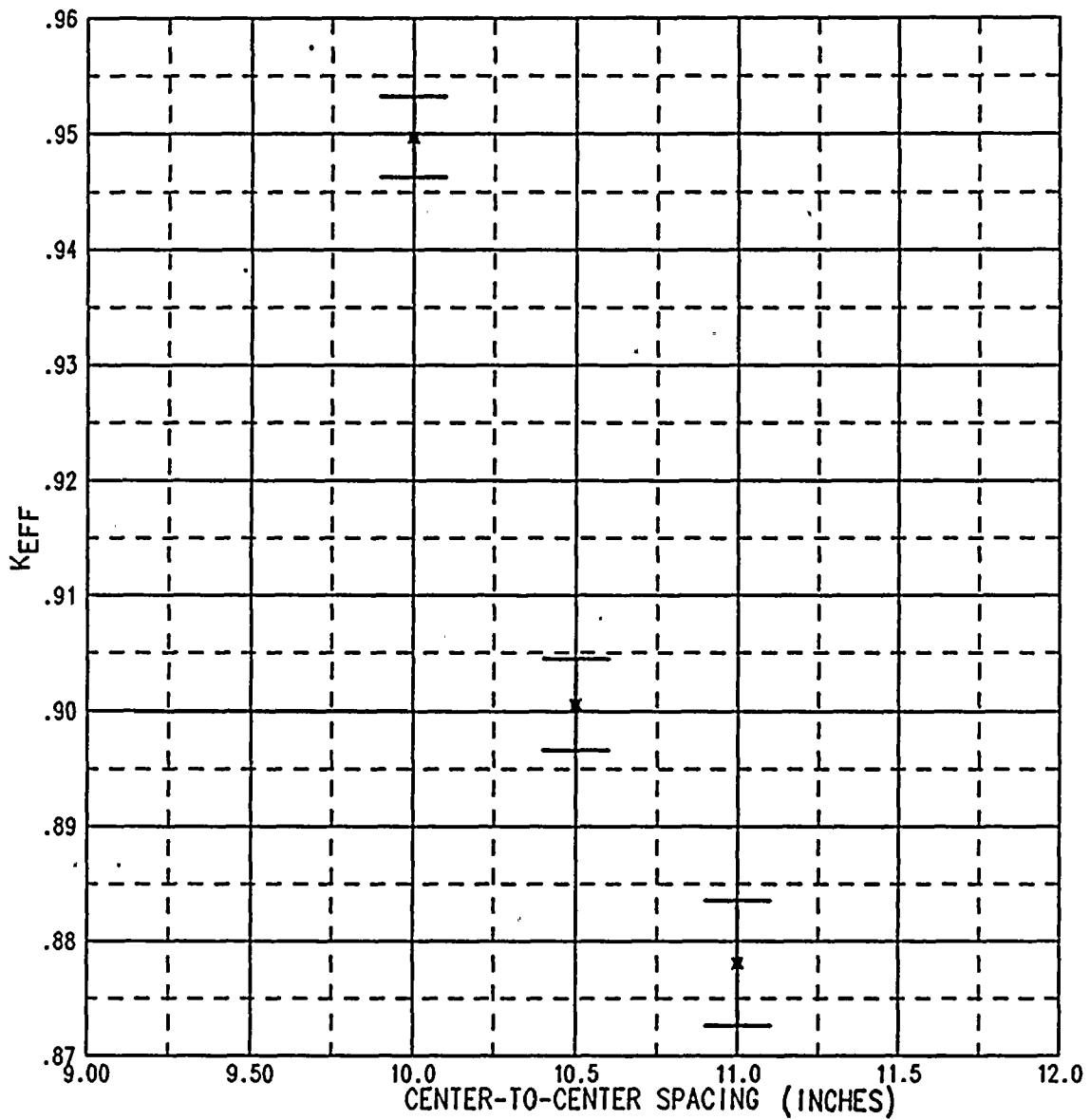

BORAL HELD AT .02 GM B10/CM2
 ENRICHMENT HELD AT 4.95 W/O

Figure 7. Sensitivity of K_{eff} to Center-to-Center Spacing in the Donald C Cook Nuclear Plant SFP Region 1 Storage Area with Three of Four Loading



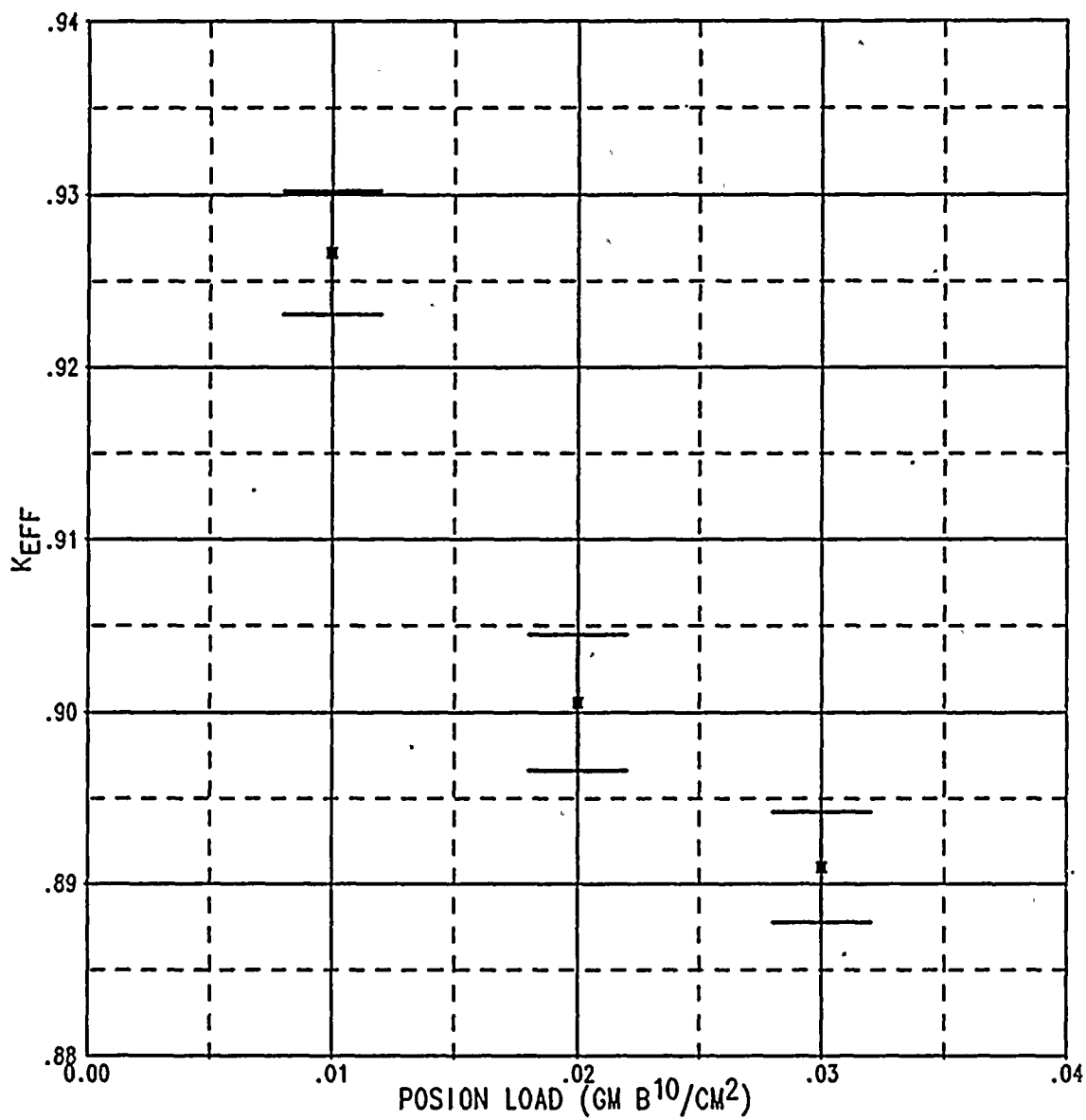

CENTER TO CENTER HELD AT 10.5"
 ENRICHMENT HELD AT 4.95 W/O

Figure 8. Sensitivity of K_{eff} to B^{10} Loading in the Donald C Cook Nuclear Plant SFP Region 1 Storage Area with Three of Four Loading



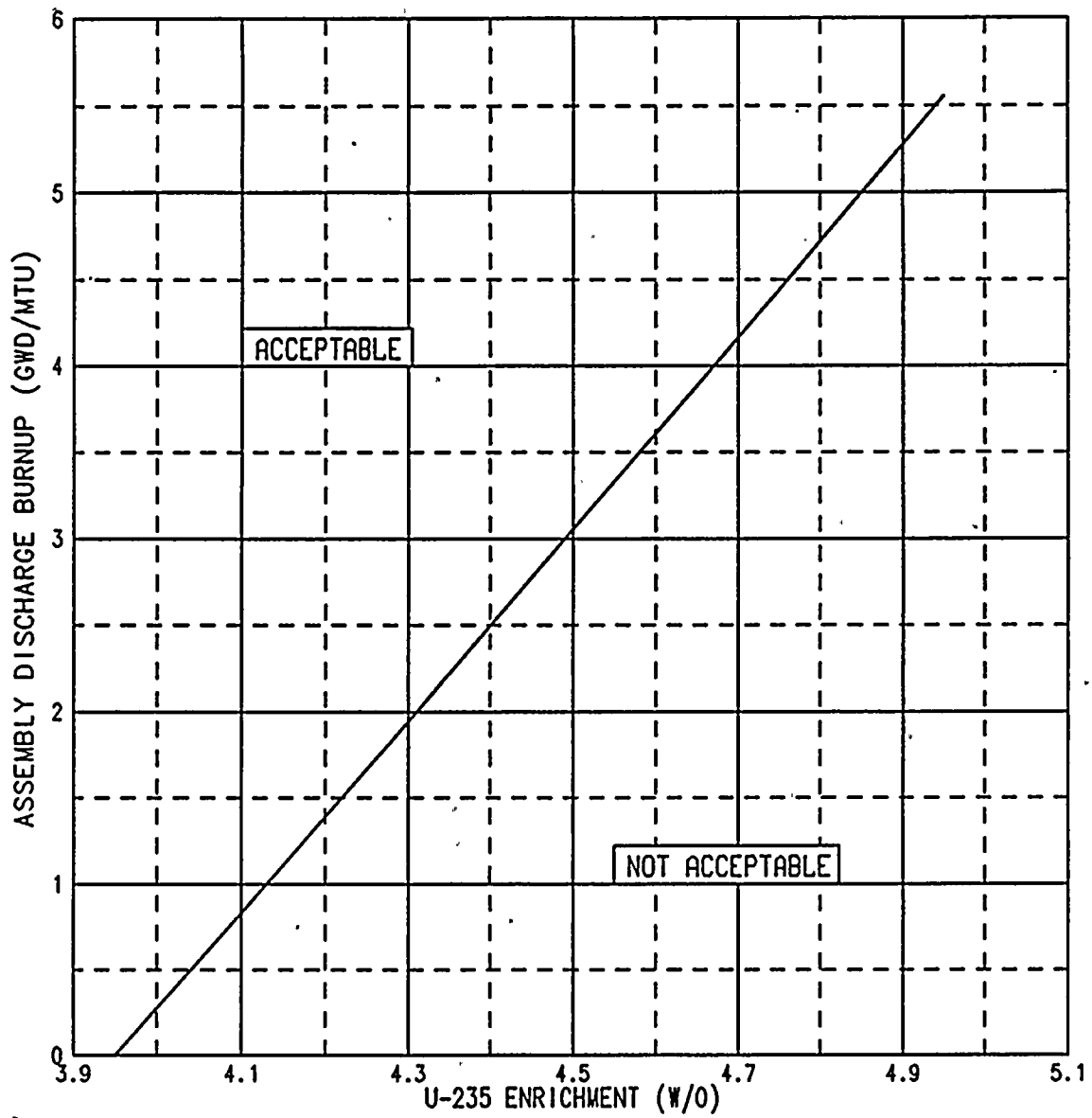
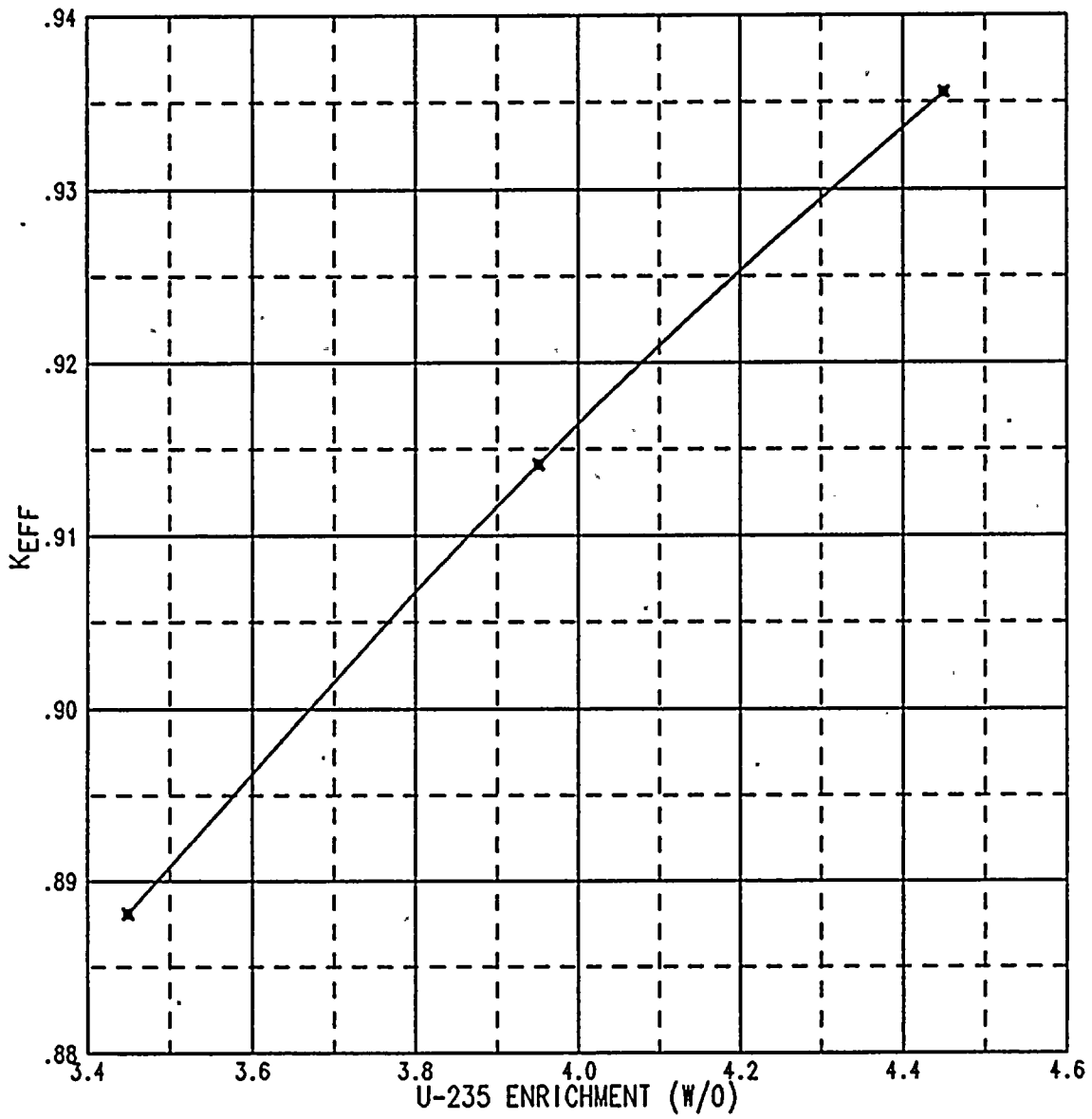

Figure 9. Donald C Cook Nuclear Plant SFP Region 2 Fuel Assembly Minimum Burnup vs. Initial U^{235} Enrichment Curve





BORAL HELD AT .02 GM B10/CM2
 CENTER TO CENTER HELD AT 10.5"

Figure 10. Sensitivity of K_{eff} to Enrichment in the Donald C Cook Nuclear Plant SFP Region 2 Storage Area



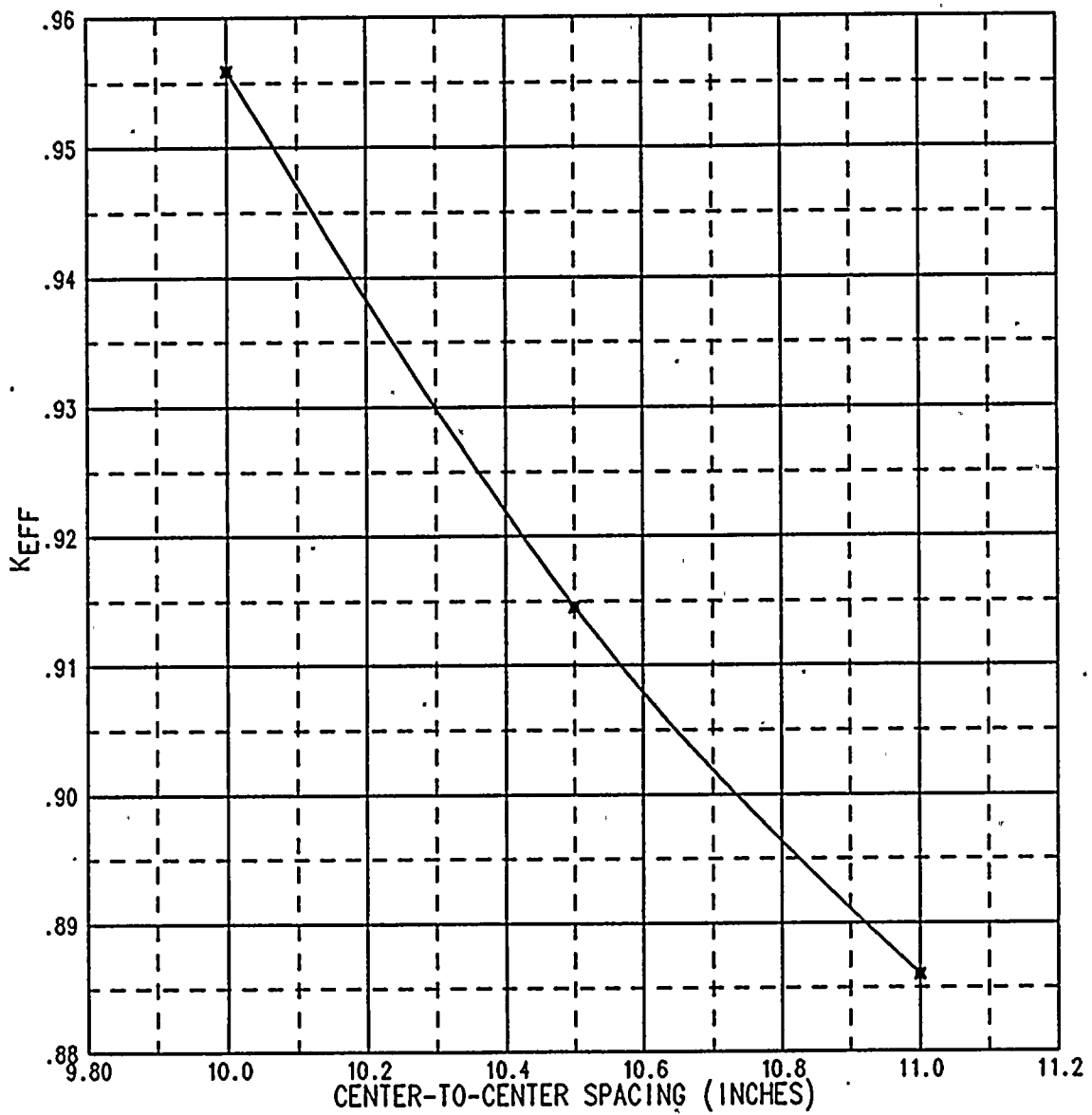

BORAL HELD AT .02 GM B10/CM2
 ENRICHMENT HELD AT 3.95 W/O

Figure 11. Sensitivity of K_{eff} to Center-to-Center Spacing in the Donald C Cook Nuclear Plant SFP Region 2 Storage Area

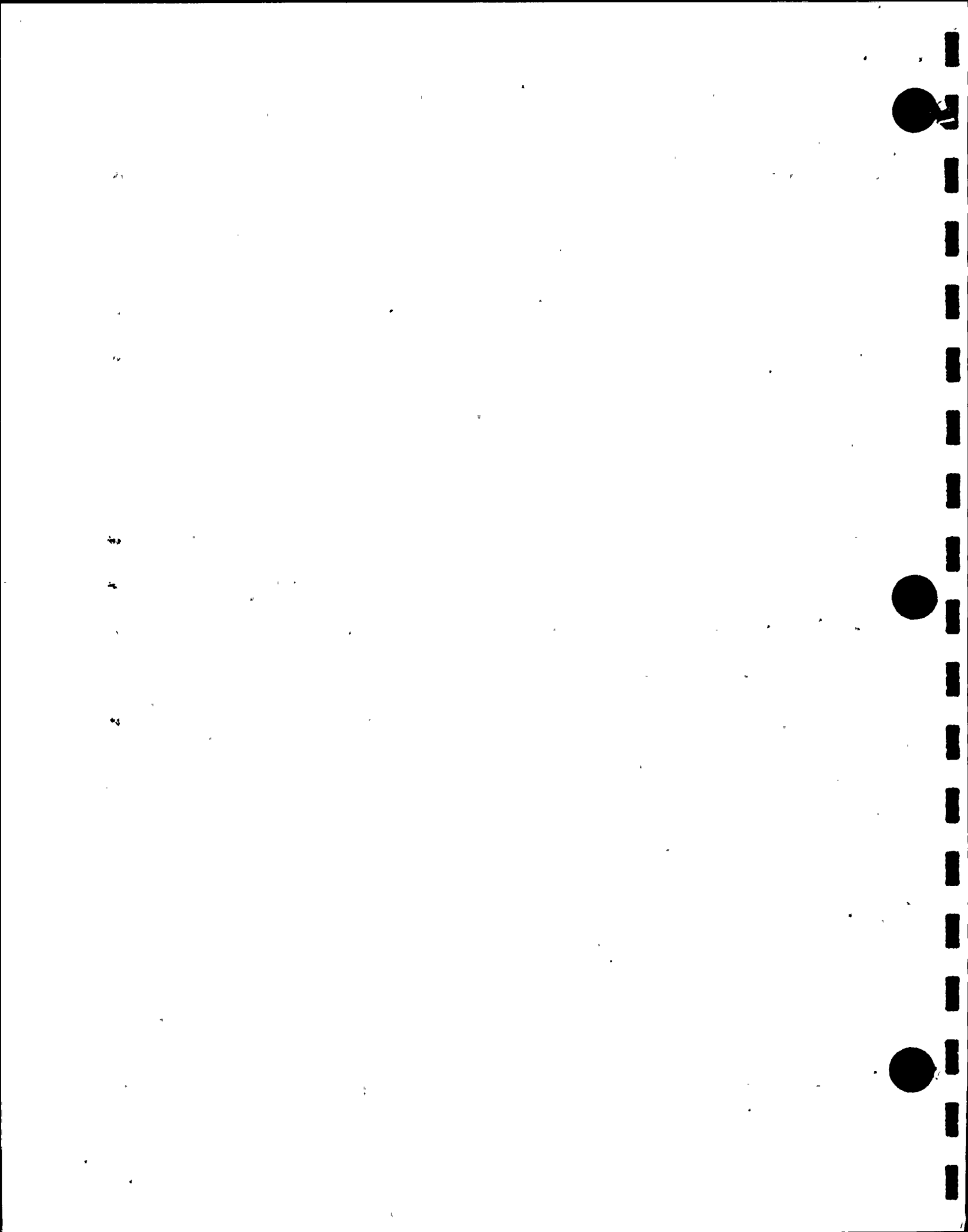

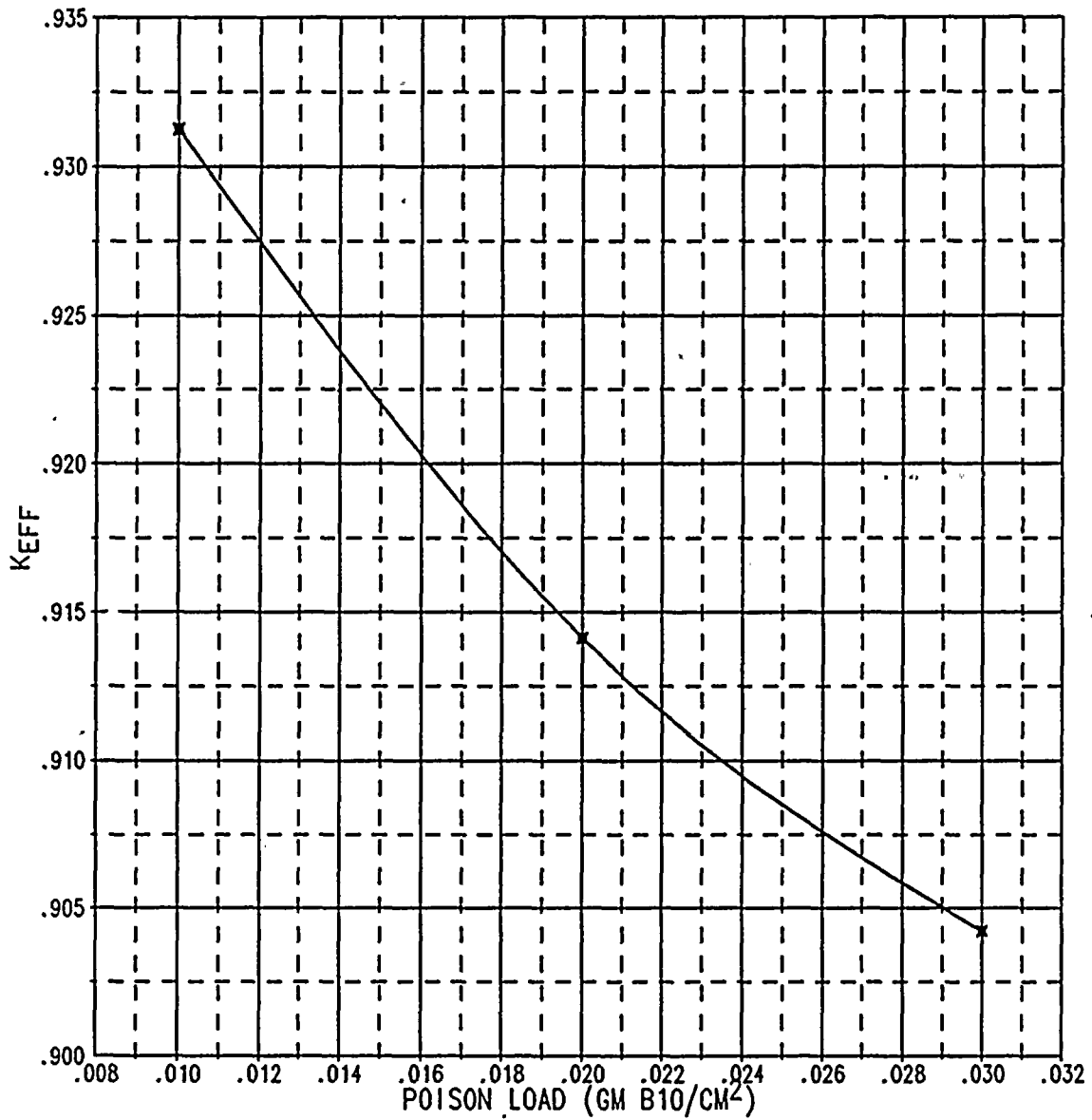

CENTER TO CENTER HELD AT 10.5"
 ENRICHMENT HELD AT 3.95 W/O

Figure 12. Sensitivity of K_{eff} to B^{10} Loading in the Donald C Cook Nuclear Plant SFP Region 2 Storage Area



24

25

26

27

28

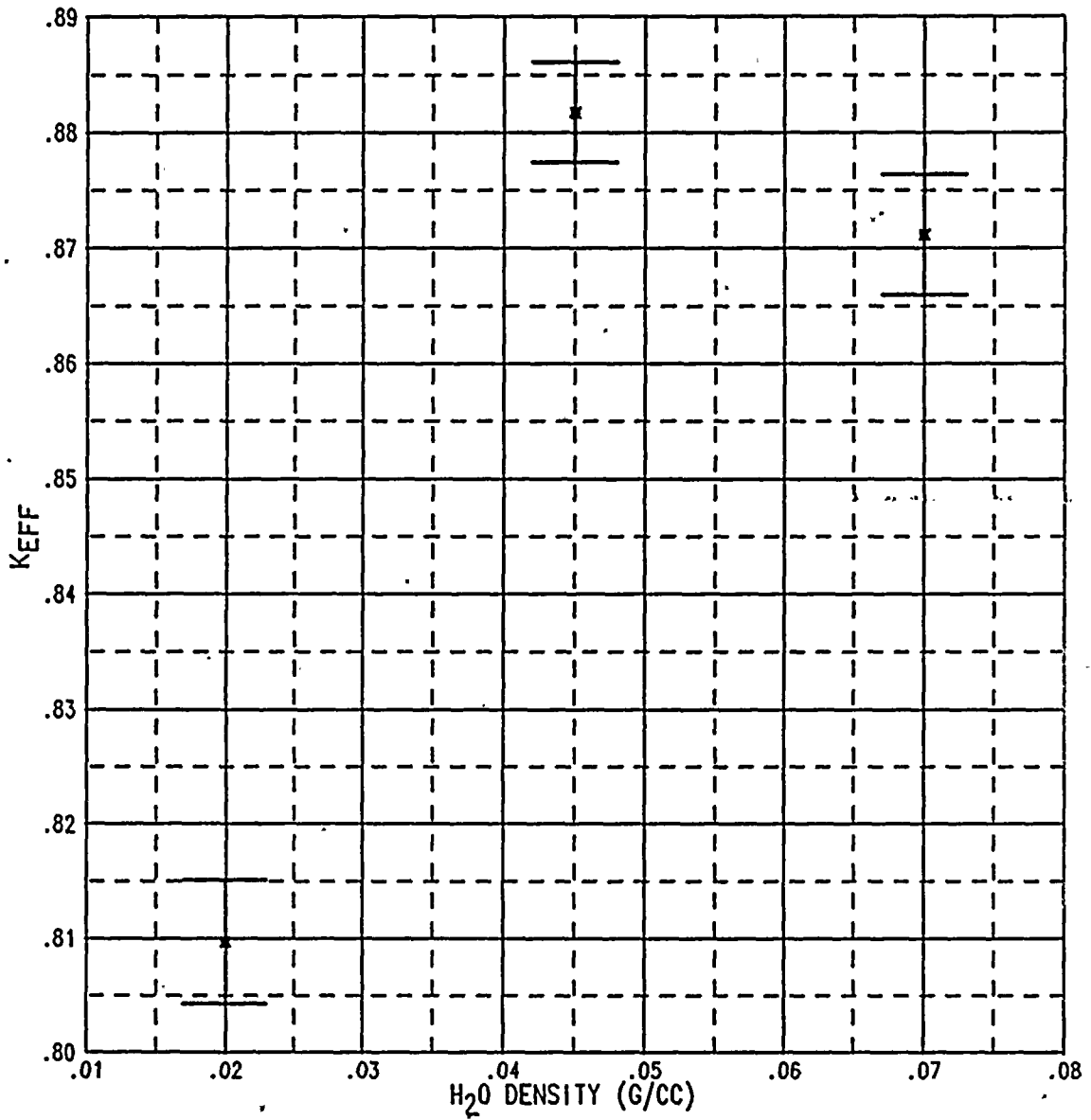
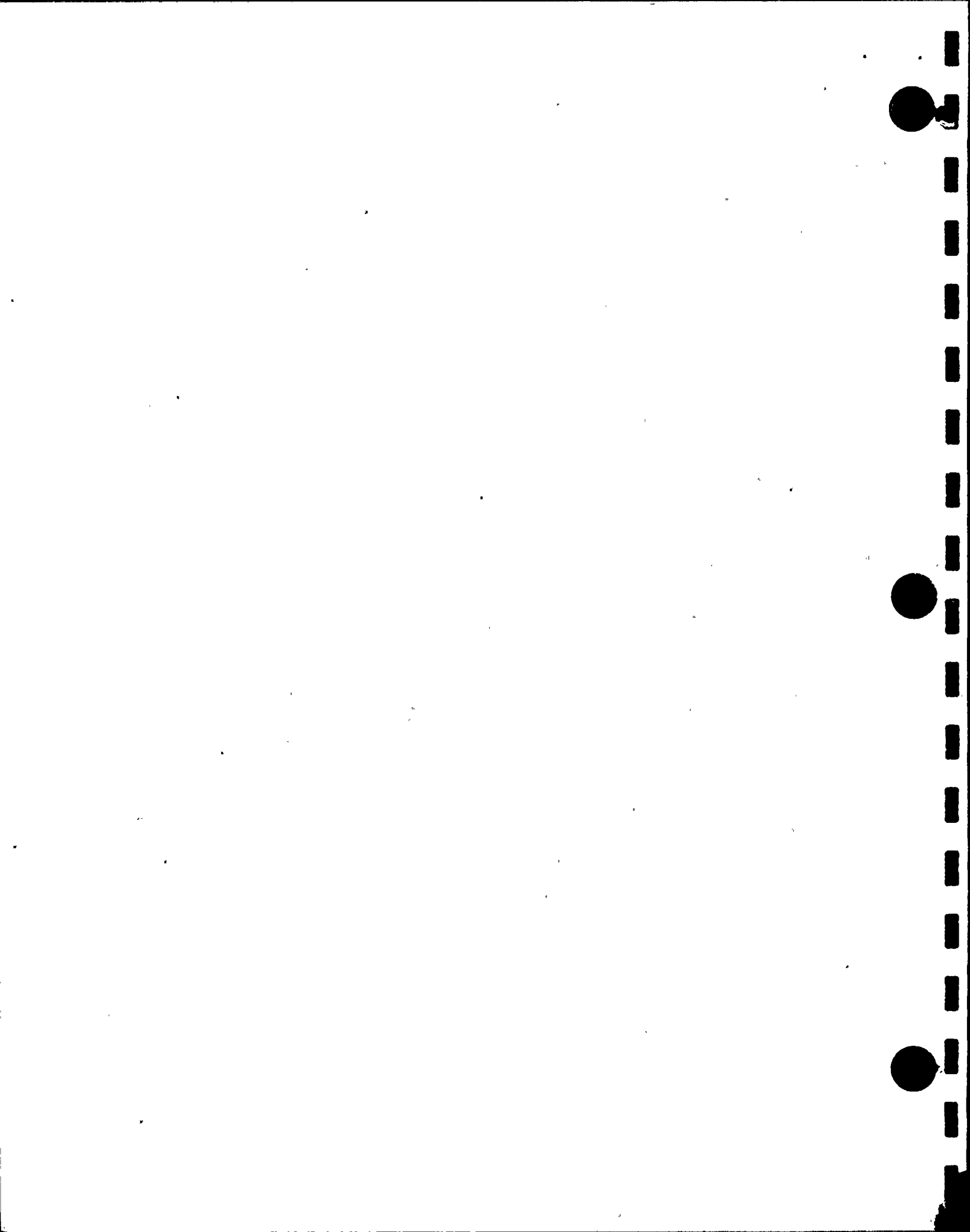

Figure 13. Sensitivity of K_{eff} to Water Density in the Donald C Cook Nuclear Plant New Fuel Storage Vault



BIBLIOGRAPHY

1. Nuclear Regulatory Commission, Letter to All Power Reactor Licensees, from B. K. Grimes *OT Position for Review and Acceptance of Spent Fuel Storage and Handling Applications*, April 14, 1978.
2. W. E. Ford III, *CSRL-V: Processed ENDF/B-V 227-Neutron-Group and Pointwise Cross-Section Libraries for Criticality Safety, Reactor and Shielding Studies*, ORNL/CSD/TM-160, June 1982.
3. N. M. Greene, *AMPX: A Modular Code System for Generating Coupled Multigroup Neutron-Gamma Libraries from ENDF/B*, ORNL/TM-3706, March 1976.
4. L. M. Petrie and N. F. Cross, *KENO IV--An Improved Monte Carlo Criticality Program*, ORNL-4938, November 1975.
5. M. N. Baldwin, *Critical Experiments Supporting Close Proximity Water Storage of Power Reactor Fuel*, BAW-1484-7, July 1979.
6. J. T. Thomas, *Critical Three-Dimensional Arrays of U(93.2) Metal Cylinders*, Nuclear Science and Engineering, Volume 52, pages 350-359, 1973.
7. D. E. Mueller, W. A. Boyd, and M. W. Fecteau (Westinghouse NFD), *Qualification of KENO Calculations with ENDF/B-V Cross Sections*, American Nuclear Society Transactions, Volume 56, pages 321-323, June 1986.
8. A. J. Harris, *A Description of the Nuclear Design and Analysis Programs for Boiling Water Reactors*, WCAP-10106, June 1982.
9. Askew, J. R., Fayers, F. J., and Kemshell, P. B., *A General Description of the Lattice Code WIMS*, Journal of British Nuclear Energy Society, 5, pp. 564-584, 1966.
10. England, T. R., *CINDER - A One-Point Depletion and Fission Product Program*, WAPD-TM-334, August 1962.
11. Melehan, J. B., *Yankee Core Evaluation Program Final Report*, WCAP-3017-6094, January 1971.



ENCLOSURE 1

AEP (COOK) RESPONSE TO GENERIC LETTER 89-21

14

3
1 2 3 4 5 6 7 8 9 10 11 12 13 14 15 16 17 18 19 20 21 22 23 24 25 26 27 28 29 30 31 32 33 34 35 36 37 38 39 40 41 42 43 44 45 46 47 48 49 50 51 52 53 54 55 56 57 58 59 60 61 62 63 64 65 66 67 68 69 70 71 72 73 74 75 76 77 78 79 80 81 82 83 84 85 86 87 88 89 90 91 92 93 94 95 96 97 98 99 100

