

**PRODUCT SPECIFICATION**

DOCUMENT NO. <b>E7012/E7022</b>	PREPARED <i>F. Kissler</i>	DATE <i>4/3/80</i>	<b>NUCLEAR SAFETY RELATED</b>
TITLE <b>MODEL E7012/E7022 SERIES TIMING RELAYS CLASS 1E</b>	CHECKED <i>J. K. Drubb</i>	<i>4/3/80</i>	
	APPROVED <i>P. Lenz</i>	<i>4/3/80</i>	
	APPROVED <i>A. J. Kuch</i>	<i>4/3/80</i>	

**REVISION INDEX**

ECO	REV	SHEETS EFF.	DATE	ECO	REV	SHEETS EFF.	DATE
80-47	D	ALL	4-3-80				
81-173	E	1, 6, 22	9-15-81				

REVISION STATUS OF SHEETS	REV.	E	D	D	D	D	E	D	D	D	D	D	D	D	D	D	D	D	D	E		
	SHEET	1	2	3	4	5	6	7	8	9	10	11	12	13	14	15	16	17	18	19	20	21

**1.0 PURPOSE**

1.1 The purpose of this specification is to define the performance characteristics of Control Products Division of Amerace Corp. (CTP) Agastat<sup>®</sup> relays identified herein. The performance characteristics stated were derived from the results of a qualification test program, which was designed to measure the performance of the devices under normal and abnormal (Design Basis Events) conditions as specified. The qualification test program used was in accordance with the requirements of IEEE STD. 323-1974 (IEEE Standard for Qualifying Class 1E Equipment for Nuclear Power Generating Stations) and IEEE STD. 344-1975 (IEEE Recommended Practice for Seismic Qualification of Class 1E Equipment for Nuclear Power Generating Stations).

**NOTE**

In the following information, reference will also be made to IEEE STD. 501-1978 (IEEE Standard for Seismic Testing of Relays)

**2.0 LIMITATIONS OF TEST RESULTS:**

- 2.1 Since it is not possible to define the conditions for every conceivable application for relays, those parameters, which in practice encompass the majority of applications, have been specified.
- 2.2 If this data is not applicable to a particular requirement; then proof testing must be performed for that particular case.

8406060036 840601  
PDR ADCK 05000315  
P PDR



**CONTROL PRODUCTS  
DIVISION**

AMERACE CORPORATION  
CONTROL PRODUCTS DIVISION  
UNION, N.J. 07083

DOCUMENT NO. E7012/E7022

REV. E

SHEET 1 OF 22

- 2.3 The data documented in this specification applies only to Agastat® relays mounted on rigid test fixtures and does not apply to relays mounted on switch boards, panels or any structure.
- 2.4 It is the responsibility of the power system facility designers to combine data on seismic and environmental performance of the relays to arrive at an acceptable equipment design for a particular application.

NOTE

Control Products Division of Amerace Corporation does not recommend the use of its products in the containment areas of nuclear power generating stations.

3.0 QUALIFICATION TEST OUTLINE.

- 3.1 AGING SIMULATION. (10 year or 25,000 operations qualified life). The following sequence of tests was performed on Agastat® devices identified herein (prior to seismic fragility testing). The sole intent being that the combination of these tests, with applied margins, degraded the relays and their related hardware to a state which constitutes the equivalency of their end of service condition to satisfy the aging requirements of IEEE STD. 323-1974 and IEEE STD. 344-1975.

3.1.1 Aging Sequence.

- (a) Radiation Aging. ( $2.0 \times 10^5$  rads integrated dose.) This dosage is considered to be of sufficient integrated exposure, with margin included that exceeds the adverse plant operating requirements for areas outside the reactor containment building. Mainly the auxiliary and control buildings.
- (b) Cycling with Load Aging. (27,500 operations with one set of contacts loaded to 120 vac, 60 Hz at 10 amp or 125 vdc at 1 amp, which is rated load.) The objective of this test was to operate the devices at an accelerated rate with contacts loaded. The intent being to exceed by 10% the amount of mechanical operations the relays will see in service. Also, by loading the contacts, the wear at the end of the test should exceed their normal end of qualified life conditions.

NOTE

10% margin added to cycles (25,000 plus 10% = 27,500 operations)



CONTROL PRODUCTS  
DIVISION

AMERACE CORPORATION  
CONTROL PRODUCTS DIVISION  
UNION, N.J. 07083

DOCUMENT NO. E7012/E7022

REV. D

SHEET 2 OF 2

- (c) Temperature Aging. (100°C for 42 days)  
This test subjected the relays to an artificially elevated temperature (100°C) for an extended period of time (Forty two (42) days). The device performance was measured before and after the thermal stress. Negligible degradation in device performance stands as evidence of capability to handle the thermal aging requirements of Class 1E applications.
- (d) Seismic Aging. Since this was basically a fragility type test, sufficient interactions were performed at levels less than the fragility level of the devices in order to satisfy, with required margins, the seismic aging requirements of IEEE STD. 323-1974 and IEEE STD, 344-1975.

### 3.2 BASELINE PERFORMANCE TESTS.

3.2.1 In addition to the aging tests, a series of baseline tests were conducted before (in order to establish a data base) and then immediately following each aging sequence, with the purpose being to measure the effects, if any, on the various devices.

3.2.2 The baseline tests consisted of:

- (a) Pull-in Voltage
- (b) Drop-out Voltage
- (c) Dielectric Strength at 1650 vac, 60 Hz
- (d) Insulation Resistance at 500 vdc
- (e) Operate Time (Milliseconds)
- (f) Recycle Time (Milliseconds)
- (g) Time Delay (Seconds)
- (h) Repeatability (%)
- (i) Contact Bounce (Milliseconds at 28 vdc, 1 ampere)
- (j) Contact Resistance (Milliohms at 28 vdc, 1 ampere)

3.2.3 The data from these tests was measured and recorded. This data was used for comparison to functional data throughout the qualification test program to measure any degradation in the performance of the relays.

### 3.3 SEISMIC QUALIFICATION (IEEE STD. 344-1975 and IEEE STD. 501-1978).

3.3.1 The artificially aged devices were subjected to simulated seismic vibration, which verified the individual device's ability to perform its required function, before, during, and/or following design basis earthquakes.



CONTROL PRODUCTS  
DIVISION

AMERACE CORPORATION  
CONTROL PRODUCTS DIVISION  
UNION, N.J. 07083

DOCUMENT NO. E7012/E7022

REV. D

SHEET 3 OF 22

3.3.2 Using a Generic Required Response Spectra (RRS) for control systems purposes for the majority of nuclear power plant locations in the continental United States as a Guideline, the devices should have met, exceeded, and/or established their own fragility levels.

3.3.3 The relays were tested in the following electrical states.

- (a) Non-operating Mode (Relay coil deenergized - off-delay relays timed out).
- (b) Operating Mode (Relay coils energized - on-delay relays timed out).with nominal rated voltage less 10% applied to coils.
- (c) Transitional Mode (Relay time delay) with nominal rated voltage, less 10%, applied to coils. Relays timed out twice during seismic test.

#### 3.4 HOSTILE ENVIRONMENT.

3.4.1 The relays are not recommended for use in the actual reactor containment area, but are intended mainly for use in the auxiliary and control buildings. Therefore, in lieu of a loss-of-coolant accident (LOCA) test, a hostile environment test was performed.

3.4.2 After simulated aging and seismic fragility testing, a combination temperature/humidity and under/over voltage test was conducted in order to demonstrate that the devices will function under adverse plant operating conditions even after having undergone all the aforementioned aging simulation and seismic qualification testing.

3.4.3 The relays were operated at minimum and maximum voltage extremes; 85 and 120 percent of rated voltage for AC devices and 80 and 120 percent of rated voltages for DC devices.

**NOTE**

Plus 10% was added to maximum rated voltages to satisfy margin requirements per IEEE STD. 323-1974.

3.4.4 Five (5) minimum voltage and five (5) maximum voltage operations were performed (time delays recorded) in each of the following environmental conditions: 95% relative humidity at 40°F, 50°F, 70°F, 90°F, 110°F, 130°F, 150°F, 165°F and 172°F.

**NOTE**

Plus 15°F was added to maximum use temperature (156°F) to satisfy the margin requirements of IEEE STD. 323-1974.



**CONTROL PRODUCTS  
DIVISION**

AMERACE CORPORATION  
CONTROL PRODUCTS DIVISION  
UNION, N.J. 07083

DOCUMENT NO. E7012/E7022

REV. D

SHEET 4 OF 22

### 3.5 POST TEST INSPECTION

3.5.1 Upon completion of all testing, each relay was thoroughly inspected. The condition of mechanical and electrical parts and the relay case was recorded.

### 3.6 QUALIFICATION TEST SUMMARY.

3.6.1 The Baseline Performance Tests (Para. 3.2) were conducted before and after each special test in order to measure and record any effects on the various devices.

3.6.2 The Qualification Test was conducted in the following sequence.

- (a) Baseline Test (Initial)
- (b) Radiation - Aging Test
- (c) Baseline Test - (Repeated)
- (d) Cycling with Load - Aging Test
- (e) Baseline Test (Repeated)
- (f) Temperature - Aging Test
- (g) Baseline Test (Repeated)
- (h) Seismic Aging and Qualification Test
- (i) Baseline Test (Repeated)
- (j) Hostile Environment Test
- (k) Baseline Test (Final)
- (l) Post Test Inspection

### 4.0 DEVICE IDENTIFICATION

#### 4.1 CATALOG CODE NUMBERS

4.1.1 Figure 1 illustrates the method of identifying, by catalog code, the Model E7012 and E7022 series timing relays.

#### 4.2 ACTUAL MODEL NUMBERS OF DEVICES TESTED.

- (a) E7012AC001 & E7012PC001
- (b) E7022AC001 & E7022PC001



CONTROL PRODUCTS  
DIVISION

AMERACE CORPORATION  
CONTROL PRODUCTS DIVISION  
UNION, N.J. 07083

DOCUMENT NO. E7012/E7022

REV. D

SHEET 5 OF 22



CONTROL PRODUCTS  
DIVISION

AMERAGE CORPORATION  
CONTROL PRODUCTS DIVISION  
UNION, N.J. 07083

DOCUMENT NO. E7012/E7022  
REV. E SHEET 6 OF 22

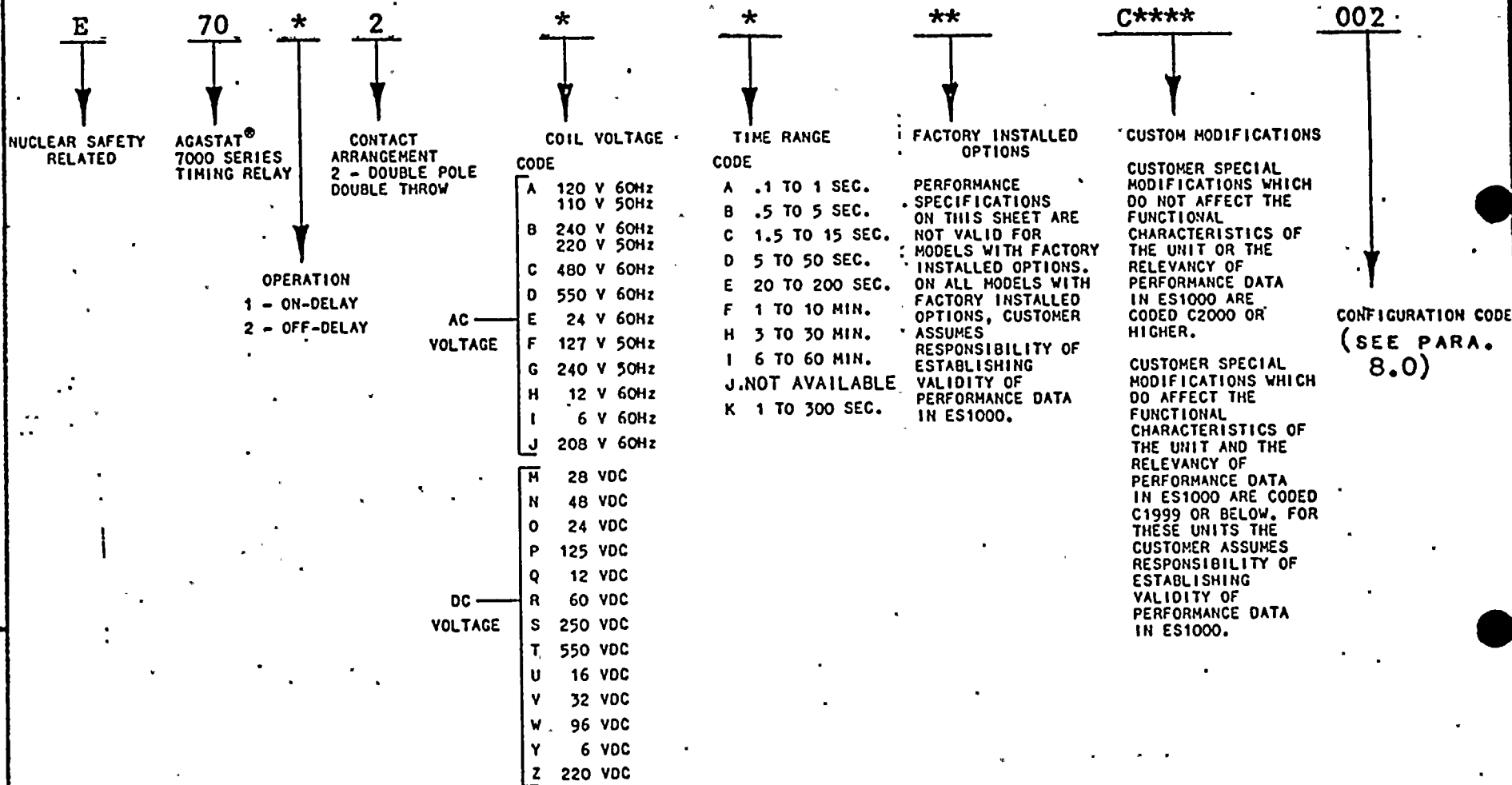

FIGURE 1. Device Code Designations

## 5.0 RELAY DESIGN CHARACTERISTICS.

### 5.1 DESCRIPTION OF OPERATION.

5.1.1 Model E7012. (See Figure 2) Applying a continuous voltage to the coil (L1-L2) starts a time delay lasting for the preset time. During this period, the normally closed contacts (3-5 and 4-6) remain closed. At the end of the delay period, the normally closed contacts break and the normally open contacts (1-5 and 2-6) make. The contacts remain in this position until the coil is deenergized, at which time the switch instantaneously returns to its original position. Deenergizing the coil, either during or after the delay period, will recycle the unit within .050 second. It will then provide a full-delay period upon reenergization, regardless of how often the coil voltage is interrupted before the unit has been permitted to "time-out" to its full-delay setting.

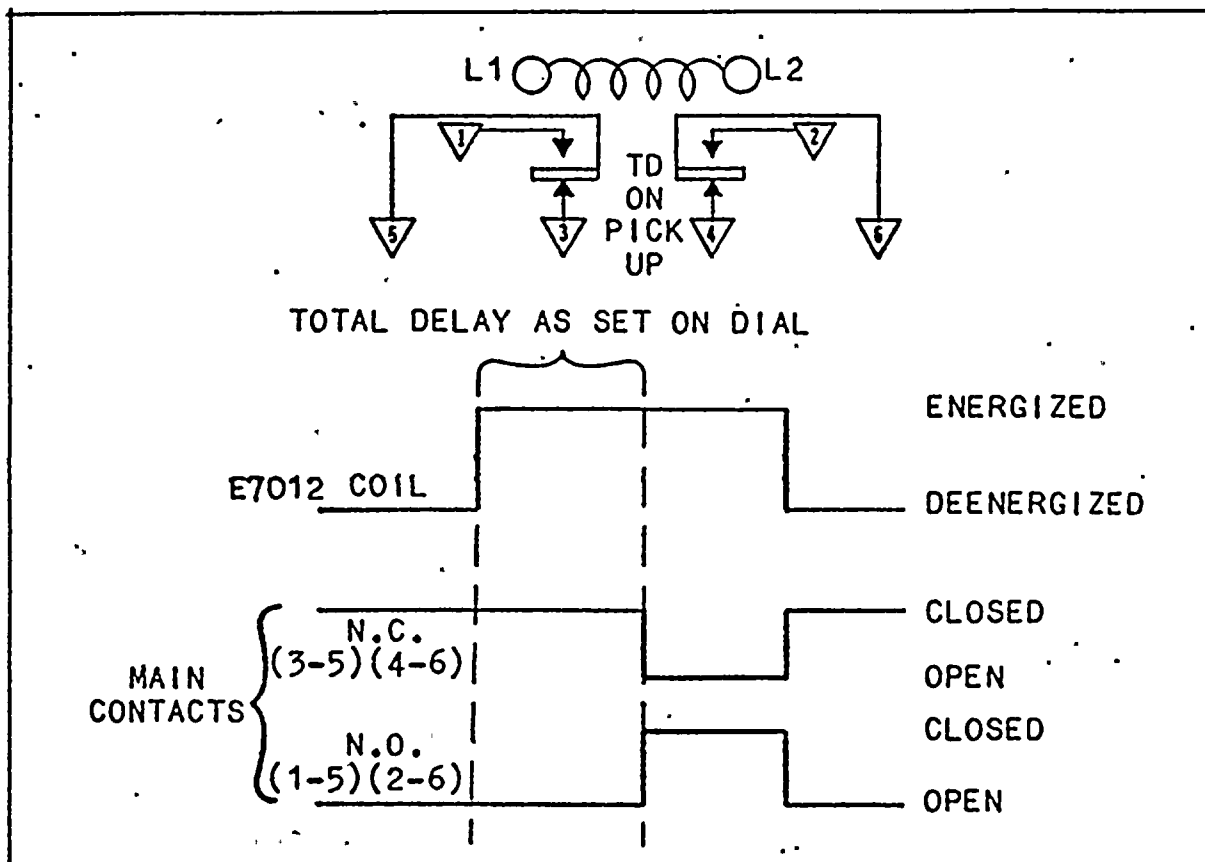

Figure 2. Operation of E7012, On-Delay Relay

5.1.2 Model E7022 (See Figure 3) Applying a voltage to the coil (L1-L2) for at least .050 second will instantaneously transfer the switch, breaking the normally closed contacts (1-5 and 2-6) and making the normally open contacts (3-5 and 4-6). Contacts remain in this transferred position as long as the coil is energized. The time delay begins immediately upon deenergization. At the end of the delay period, the switch returns to



CONTROL PRODUCTS  
DIVISION

AMERACE CORPORATION  
CONTROL PRODUCTS DIVISION  
UNION, N.J. 07083

DOCUMENT NO. E7012/E7022

REV. D

SHEET 7 OF 22

its normal position. Reenergizing the coil during the delay period will immediately return the timing mechanism to a point where it will provide a full-delay period upon subsequent de-energization. The switch remains in the transferred position.

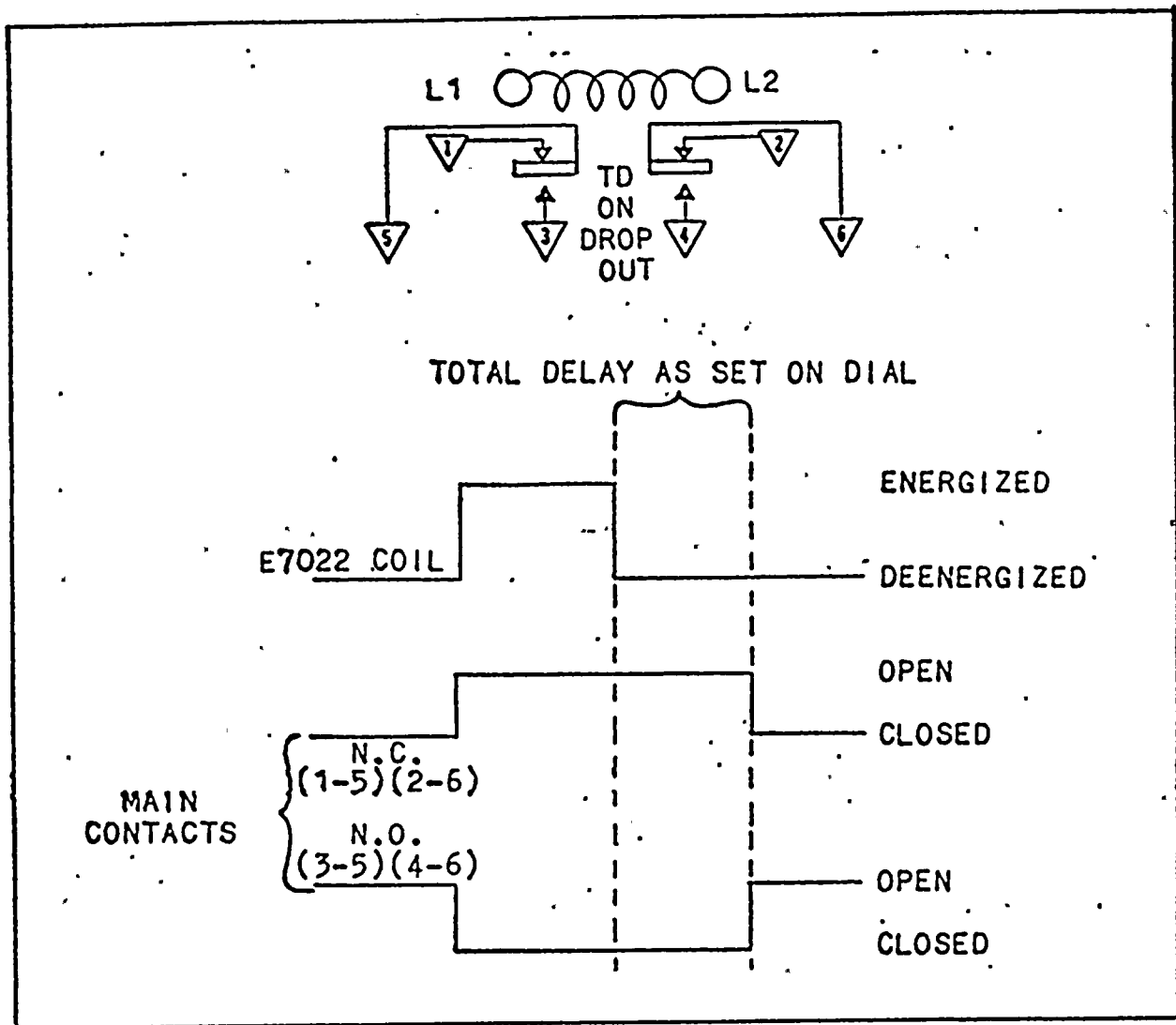

Figure 3. Operation of E7022, Off-Delay Relay.

## 5.2 PHYSICAL CHARACTERISTICS.

### 5.2.1 Relay Dimensions (See Figure 4)



CONTROL PRODUCTS  
DIVISION

AMERACE CORPORATION  
CONTROL PRODUCTS DIVISION  
UNION, N.J. 07083

DOCUMENT NO. E7012/E7022

REV. D

SHEET 8 OF 22



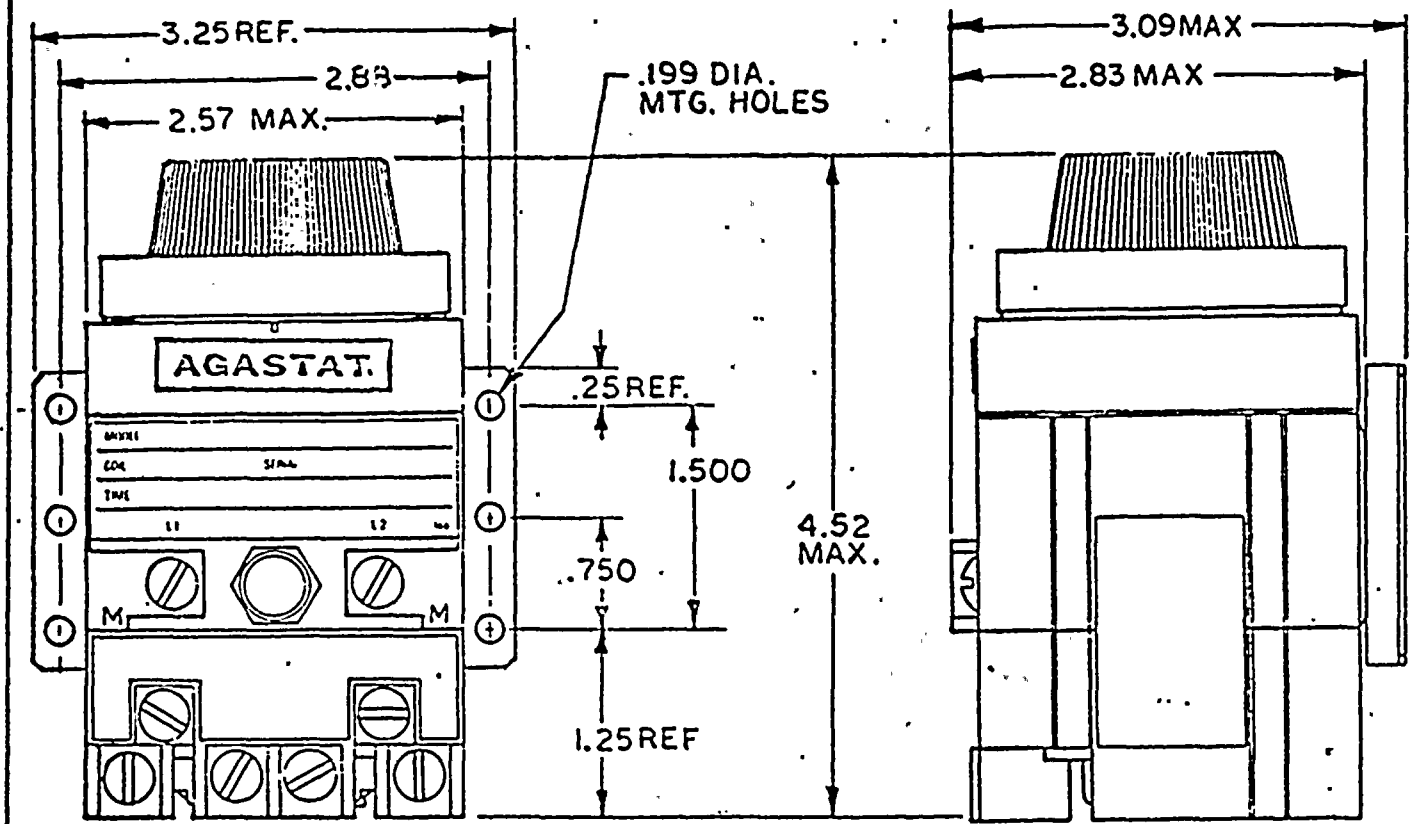

QUALIFICATION TESTED FOR VERTICAL OPERATION ONLY

Figure 4. Model E7012 and E7022 Outline and Dimension Drawing.

5.2.2 Approximate Weight.

- (a) Model E7012 and E7022 with (AC) coils - 2.13 lbs.
- (b) Model E7012 and E7022 with (DC) coils - 2.25 lbs.

NOTE

Weight may vary slightly with relay coil voltage specified.

5.2.3 Terminals. Standard screw terminals (#8-32 truss head screws supplied) are located on the front of the unit with permanent schematic markings. Barrier isolation is designed to accommodate spade or ring tongue terminals with spacing to meet industrial control specifications.



CONTROL PRODUCTS  
DIVISION

AMERACE CORPORATION  
CONTROL PRODUCTS DIVISION  
UNION, N.J. 07083

DOCUMENT NO. E7012/E7022

REV. D

SHEET 9 OF 22

5.2.4 Linear Time Range Adjustment. Basic models are furnished with dials calibrated in linear increments covering the range selected.

5.3 OPERATING CHARACTERISTICS.

5.3.1 Environmental Conditions. (Qualified Life)

PARAMETER	MIN.	NORMAL	MAX.
Temperature (°F)	40	70-104	156
Humidity (R.H: %)	10	40-60	95
Pressure	--	Atmospheric	---
Radiation (rads)	--	-----	2.0 X 10 <sup>5</sup> (Gamma)

5.3.2 Operating Conditions. (Normal Environment)

NORMAL OPERATING SPECIFICATIONS	RELAYS W/ (DC) COILS	RELAYS W/ (AC) COILS
Coil Operating Voltage, Nominal (Rated)	As Spec	As Spec
Pull-in (% of rated value)	80% Min.	85% Min.
Drop-out (% of rated value)	10% Approx.	50% Approx.
Power (Watts at rated value)	8 Approx.	8 Approx.
Relay Operate Time (In ms)		
Model E7012	N/A	N/A
Model E7022	50 ms Max.	50 ms Max.
Relay Release (Recycle) Time (In ms)		
Model E7012	50 ms Max.	50 Ms Max.
Model E7022	N/A	N/A
Contact Ratings, Continuous		
(Resistive at 125 vdc)	1.0 amp	1.0 amp
(Resistive at 120 vac, 60 Hz)	10.0 amp	10.0 amp
Insulation Resistance (In megohms at 500 vdc)	500 Min.	500 Min.
Dielectric (vrms, 60 Hz)		
Between Terminals and Ground	1,500	1,500
Between Non-connected Terminals	1,000	1,000
Repeat Accuracy (See definition in Paragraph 5.3.2.1)	± 10%	± 10%



**CONTROL PRODUCTS  
DIVISION**

AMERACE CORPORATION  
CONTROL PRODUCTS DIVISION  
UNION, N.J. 07083

DOCUMENT NO. E7012/E7022

REV. D

SHEET 10 OF 22

5.3.2.1 Repeat Accuracy. Repeat Accuracy at any fixed temperature is defined as (Ref. Nema Part ICS 2-218.07); "The repeat accuracy deviation ( $A_R$ ) of a time delay relay is a measure of the maximum deviation in the time delay that will be experienced in five successive operations at any particular time setting of the relay and for any particular operating voltage or current." Repeat Accuracy is obtained from the following formula:

$$A_R = 100 \frac{(T_1 - T_2)}{(T_1 + T_2)}$$

Where;  $T_1$  = Maximum Time Delay  
 $T_2$  = Minimum Time Delay

E7012 On delay on pull-in units with timing range of 3-30 min. and 6-60 min. the first delay will be approximately 15% longer than subsequent delays due to coil temperature rise.

**NOTE**

Dial settability with respect to the indicum (Marking on the regulating dials) is not included in the above repeatability value.

5.3.2.2 Dial Setting. The calibration markings, as with most timing relays, are for convenience and to reduce the required time for setting a relay to a specific value. However, relays can be set very accurately by using the following procedure:

- (a) Turn regulating dial (Located on the top of relay) to correspond with value desired.
- (b) Record one or more time delays. If more than one time delay is recorded, average the results.
- (c) Compare the value obtained with the value required. If value obtained is less than the value required, turn regulating dial clockwise slightly to increase time. If value obtained is greater than the value required, turn regulating dial counterclockwise to reduce the time.
- (d) Repeat steps (b) and (c) as necessary until required time delay is achieved.

5.3.3 Operating Conditions. (Abnormal Environment)



ADVERSE OPERATING SPECIFICATIONS	NORMAL	DBE "A"	DBE "B"	DBE "C"	DBE "D"
Temperature (°F)	70-104	40	120	145	156
Humidity (R.H. %)	40-60	10-95	10-95	10-95	10-95
Coil Operating Voltage * (% of Rated)					
Model E7012 (AC)	85-110	85-110	85-110	85-110	85-110
(AC)	80-110	80-110	80-110	90-110	90-110
Model E7022 (AC)	85-110	85-110	85-110	85-110	85-110
(DC)	80-110	80-110	80-110	80-110	80-110
Seismic Response **	—	—	—	—	—

#### NOTES

\* All coils may be operated on intermittent duty cycles at voltages 10% above listed maximums (Intermittent Duty = Maximum 50% duty cycle and 30 minutes "ON" time.)

\*\* For Seismic Response see Figures 5, 6, 7 for Model E7012 and Figures 8, 9 and 10 for Model E7022.

### 5.4 SEISMIC RESPONSE.

#### 5.4.1 Conditions of Seismic Tests.

- (a) Value of Damping Used - 5%
- (b) Device Mounting - Vertical Only (Rigid Test Fixture)
- (c) Mode of Vibration - Identical (Dependent) Biaxial Inputs (45° Thruster)
- (d) Seismic Input - Random Multifrequency (Spaced at 1/3 Octaves Over a Range of 1-40 Hz). 30 Second Duration.

5.4.2 Response Spectrum. Figures 5, 6 and 7 (E7012) and Figures 8, 9 and 10 (E7022) represent the actual vertical and horizontal test response of the relays in their three electrical states. Using the Failure Criteria specified in Para. 5.4.4 these values were derived by combining the lowest test response spectrum (TRS) values from the four test orientations and multiplying that composite value by 0.707 due to the 45-degree inclination of the test machine. Also, superimposed on the graphs are the following:



FULL SCALE SHOCK SPECTRUM (g Peak) MODELS TESTED:

E7012AC001  
E7012PC001

1.0 □ 10 □ 100 □ 1000 □

DAMPING 5%

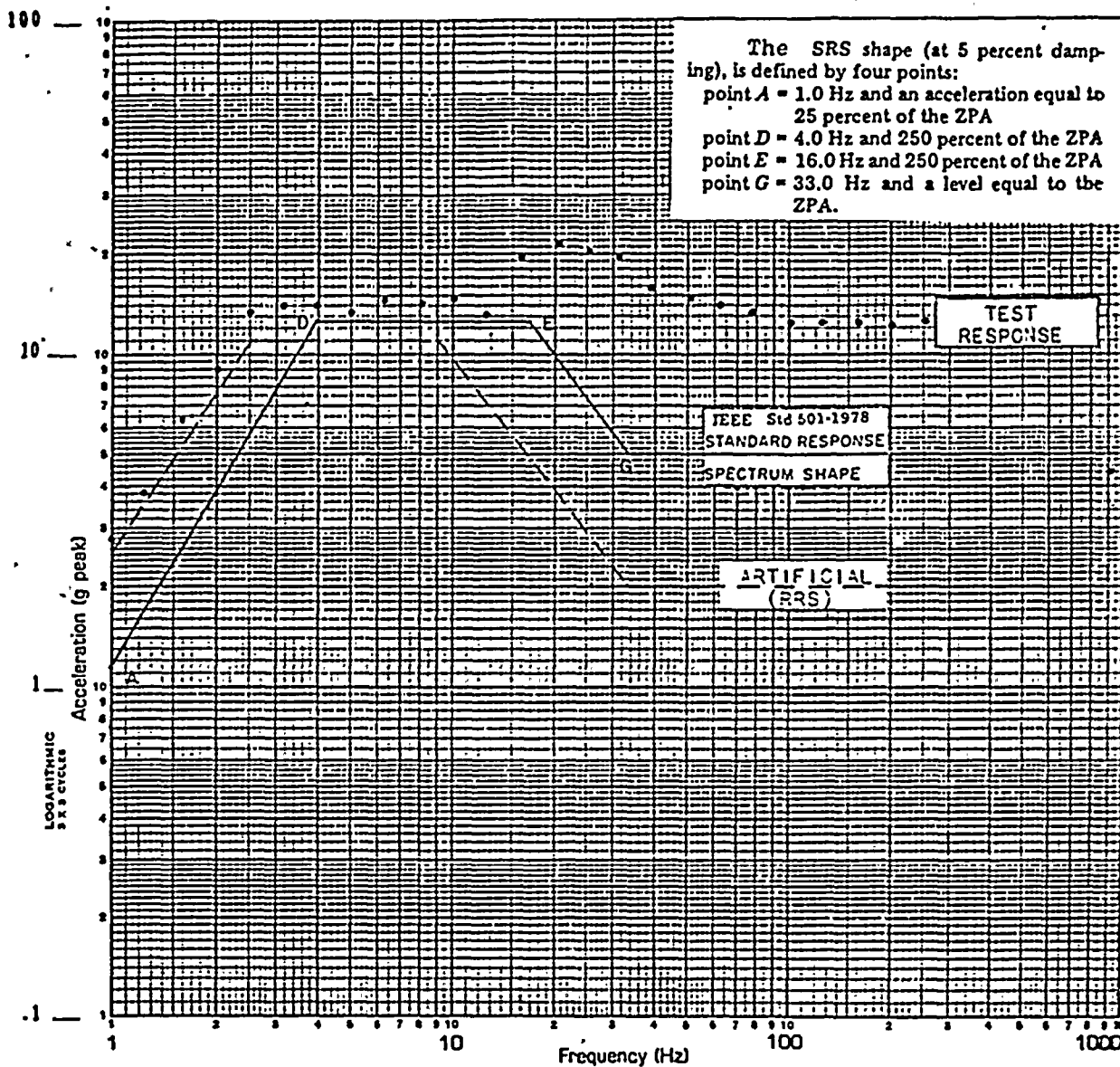

SPECIMEN 1 & 3 (E7012 SERIES) RELAY STATE: NON-OPERATE MODE (DE-ENER.)

AXIS \* SEE NOTE (H+V)

TEST RUN NO. 35, 29, 21, 11

\* COMPOSITE OF FB/V-, SS/V-, SS/V+, FB/V+ X .707 DUE TO 45° INCLINATION OF TEST MACHINE.

Figure 5. Model E7012, Response Spectrum, Non-Operate Mode



CONTROL PRODUCTS  
DIVISION

AMERACE CORPORATION  
CONTROL PRODUCTS DIVISION  
UNION, N.J. 07083

DOCUMENT NO. E7012/E7022

REV. D

SHEET 13 OF 22

FULL SCALE SHOCK SPECTRUM (g Peak)

MODELS TESTED:  
E7012AC001  
E7012PC001

1.0  10  100  1000

DAMPING  5%

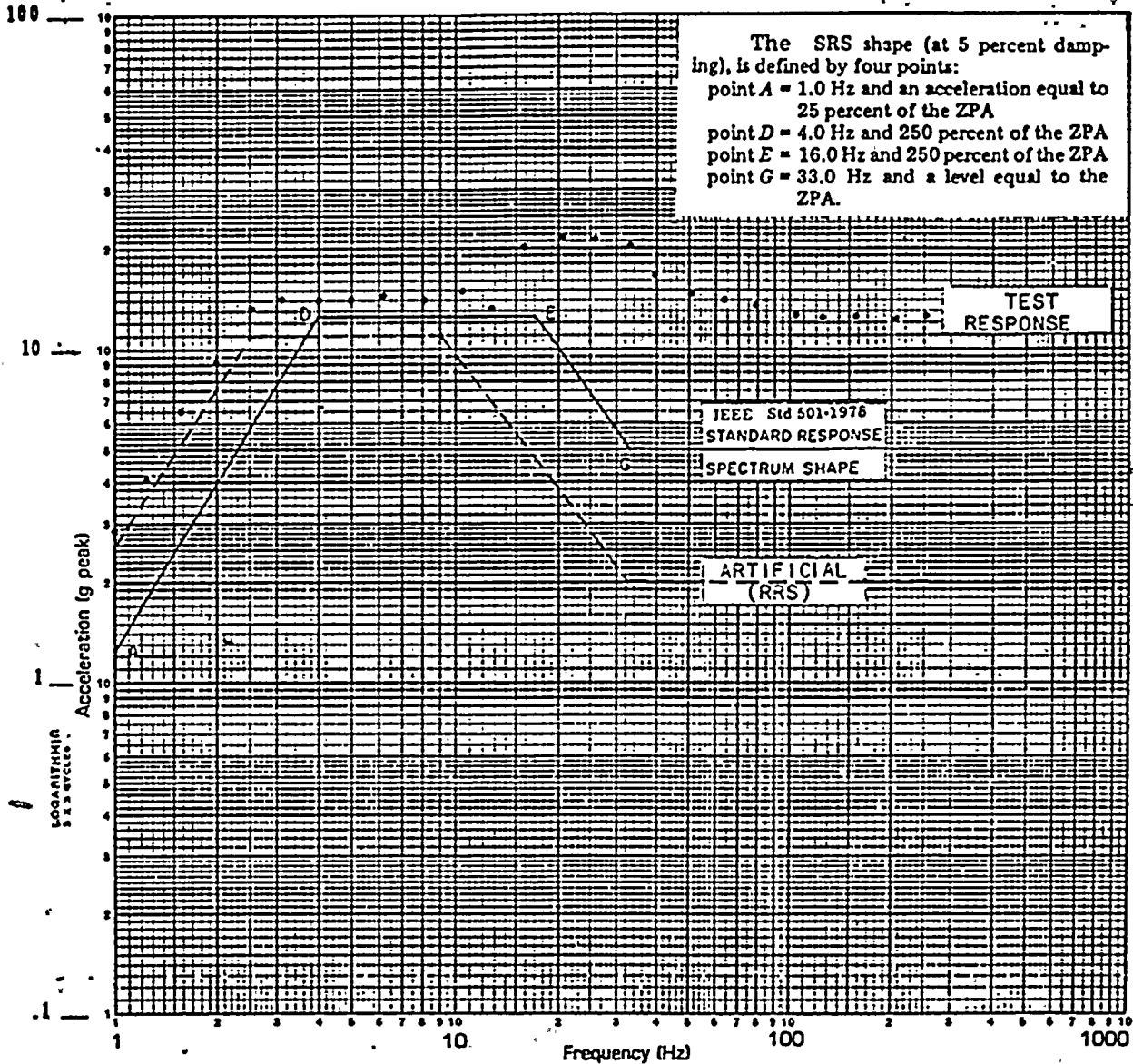

SPECIMEN 1 & 3 (E7012 SERIES) . RELAY STATE: OPERATE MODE (ENERGIZED)

AXIS \* SEE NOTE (H+V) TEST RUN NO. 40, 52, 59, 70

\* COMPOSITE OF FB/V-, SS/V-, SS/V+, FB/V+ X .707 DUE TO 45° INCLINATION OF TEST MACHINE.

Figure 6. Model E7012, Response Spectrum, Operate Mode



CONTROL PRODUCTS  
DIVISION

AMERACE CORPORATION  
CONTROL PRODUCTS DIVISION  
UNION, N.J 07083

DOCUMENT NO. E7012/E7022

REV. D

SHEET 14 OF 22

FULL SCALE SHOCK SPECTRUM (g Peak) MODELS TESTED:

E7012AC001  
E7012PC001

1.0  10  100  1000

DAMPING  5%

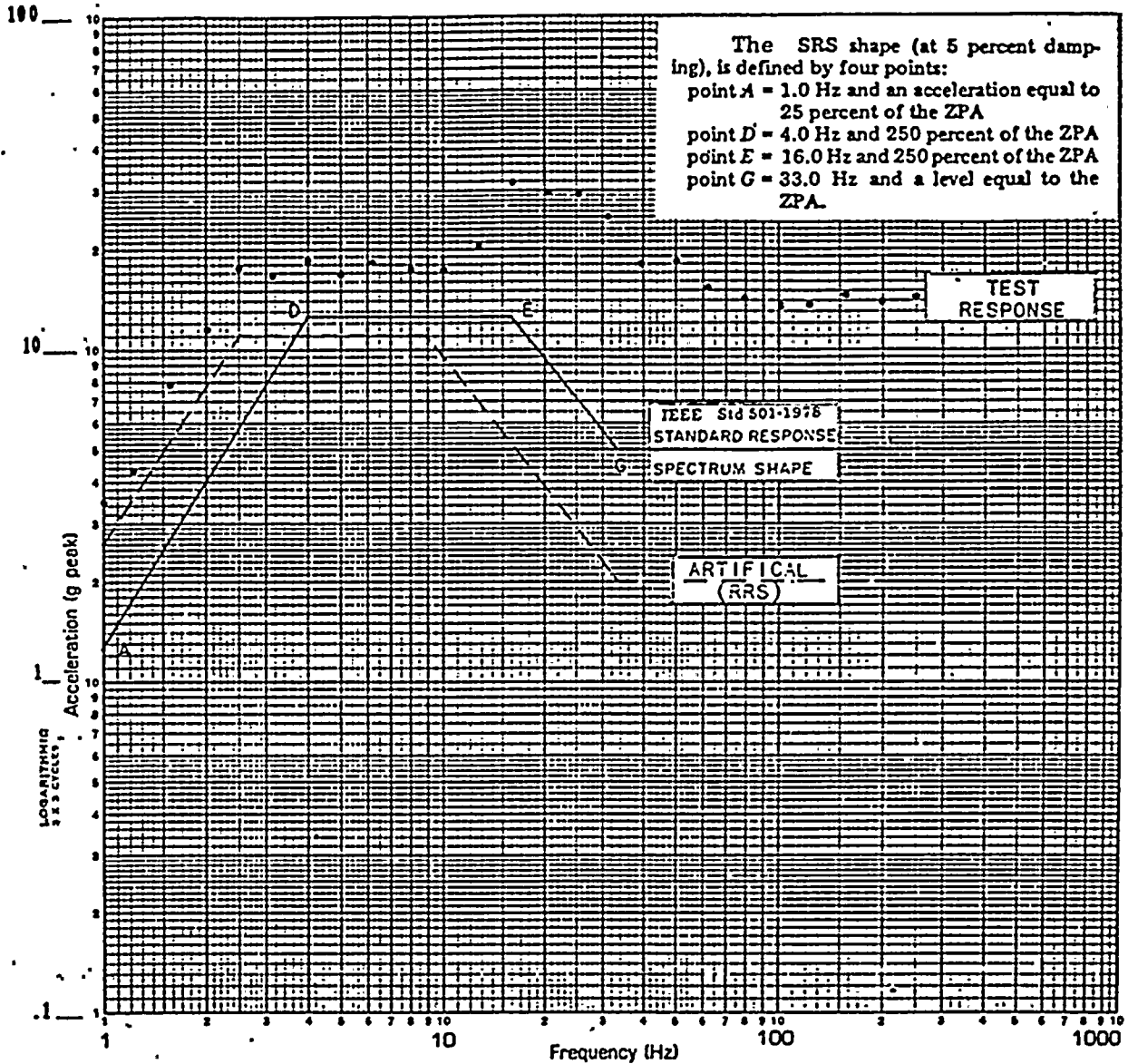

SPECIMEN 1 & 3 (E7012 SERIES) RELAY STATE: TRANSITIONAL MODE (TD X 2)

AXIS \* SEE NOTE (H+V) TEST RUN NO. 41, 45, 60, 63

\*COMPOSITE OF FB/V-, SS/V-, SS/V+, FB/V+ X .707 DUE TO 45° INCLINATION OF TEST MACHINE.

Figure 7. Model E7012, Response Spectrum, Transitional Mode



CONTROL PRODUCTS  
DIVISION

AMERACE CORPORATION  
CONTROL PRODUCTS DIVISION  
UNION, N.J. 07083

DOCUMENT NO. E7012/E7022

REV. D

SHEET 15 OF 22

FULL SCALE SHOCK SPECTRUM (g Peak) MODELS TESTED:

E7022AC001  
E7022PC001

1.0 □ 10 □ 100 □ 1000 □

DAMPING 5%

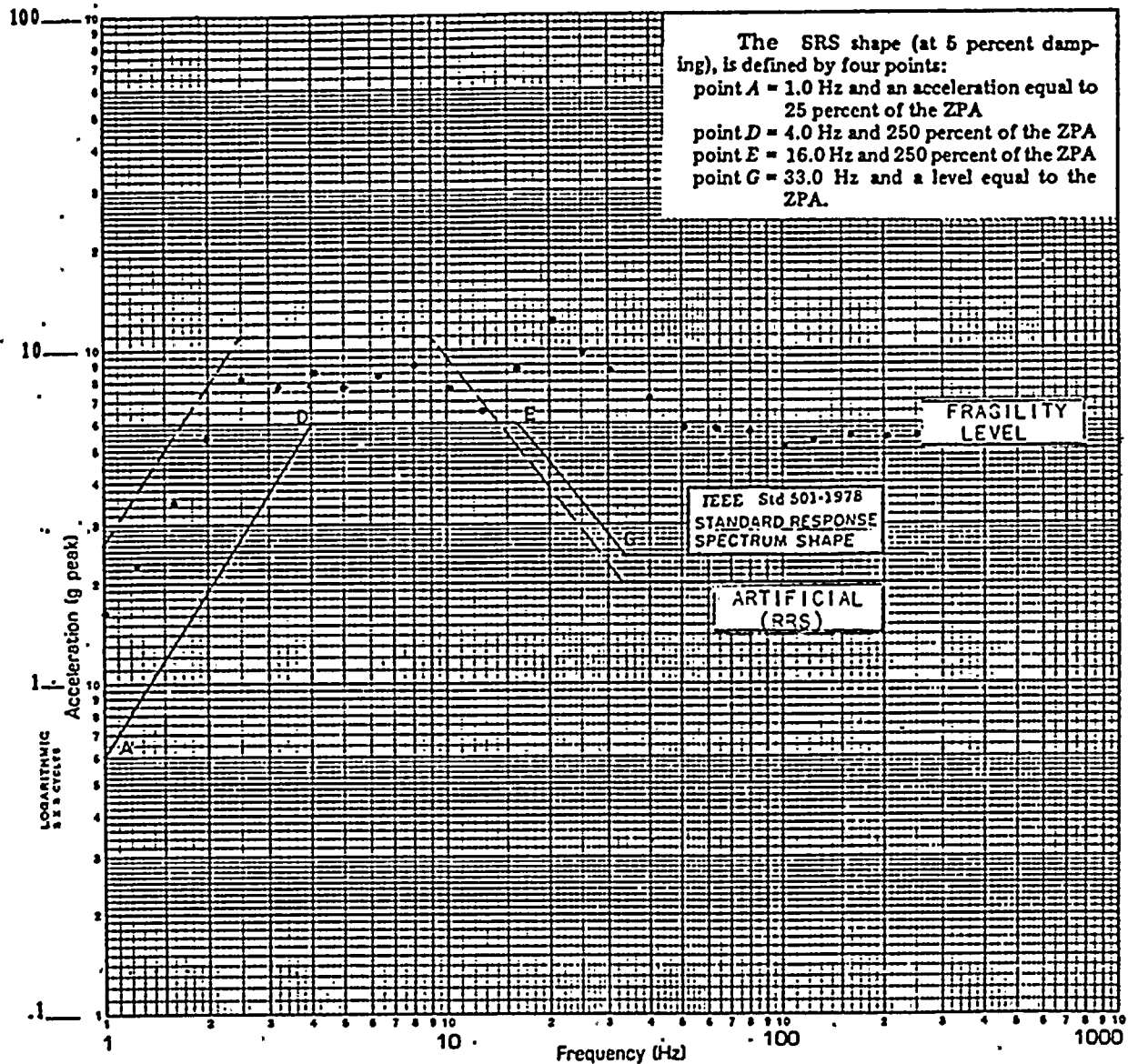

SPECIMEN 2 & 4 (E7022.SERIES) RELAY STATE: NON-OPERATE MODE (DE-ENER)

AXIS \* SEE NOTE (H+V) TEST RUN NO. (103, 104), (95, 99), 86, 76

\*COMPOSITE OF FB/V-, SS/V-, SS/V+, FB/V+ X.707 DUE TO 45° INCLINATION OF TEST MACHINE.

Figure 8. Model E7022, Response Spectrum, Non-Operate Mode



CONTROL PRODUCTS  
DIVISION

AMERACE CORPORATION  
CONTROL PRODUCTS DIVISION  
UNION, N.J. 07083

DOCUMENT NO. E7012/E7022

REV. D

SHEET 16 OF 22



FULL SCALE SHOCK SPECTRUM (g Peak)

MODELS TESTED:

E7022AC001  
E7022PC001

1.0 □ 10 □ 100 □ 1000 □

DAMPING 5%

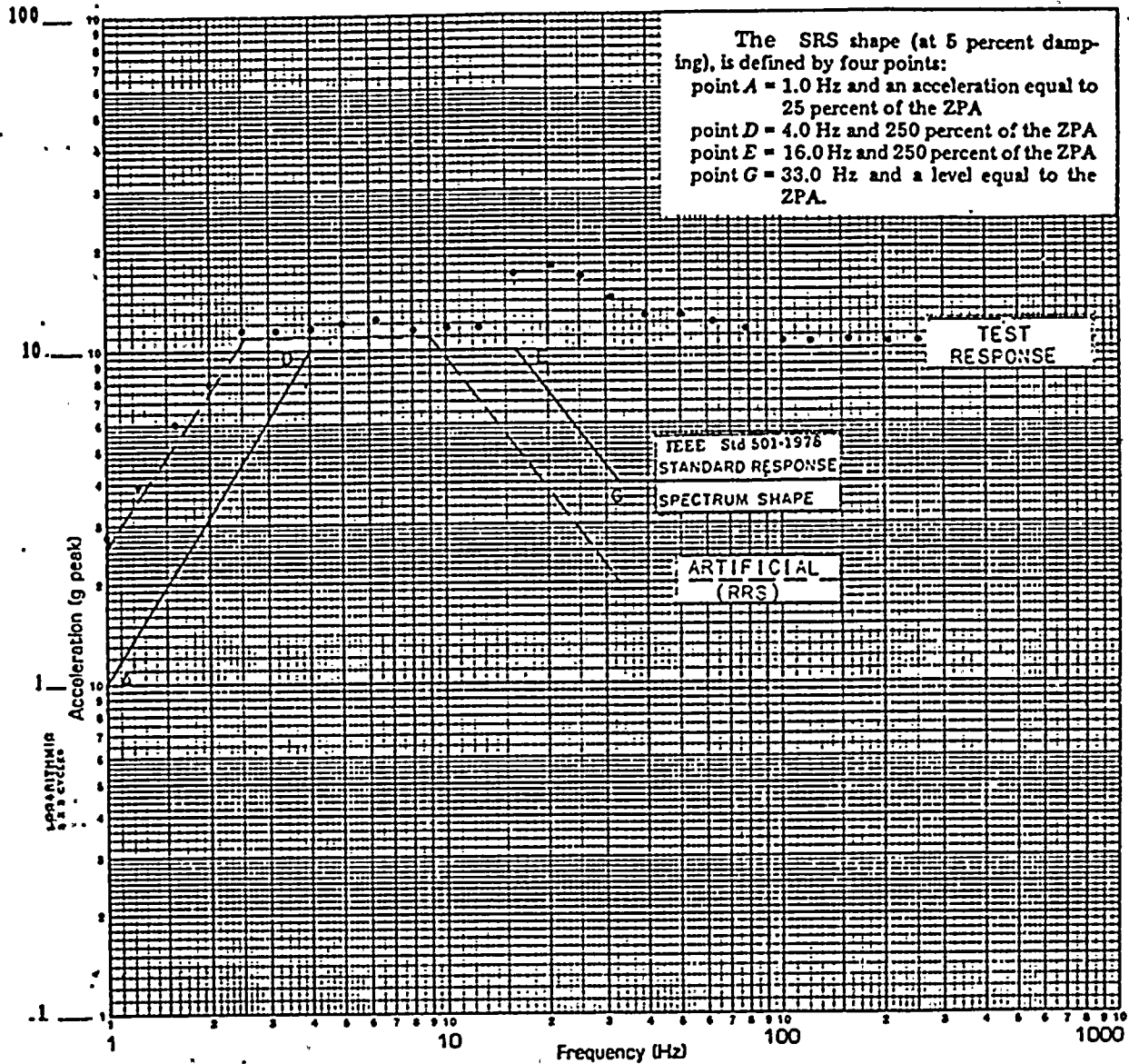

SPECIMEN 2 & 4 (E7022 SERIES) RELAY STATE: OPERATE MODE (ENERGIZED)

AXIS \* SEE NOTE (H+V)

TEST RUN NO. 312, 309, 306, +303

\* COMPOSITE OF FB/V-, SS/V-, SS/V+, FB/V+ X .707 DUE TO 45° INCLINATION OF TEST MACHINE.

Figure 9. Model E7022, Response Spectrum, Operate Mode



CONTROL PRODUCTS  
DIVISION

AMERACE CORPORATION  
CONTROL PRODUCTS DIVISION  
UNION, N. J. 07083

DOCUMENT NO. E7012/E7022

REV. D

SHEET 17 OF 22

FULL SCALE SHOCK SPECTRUM (g Peak)

MODELS TESTED:

E7022AC001  
E7022PC001

1.0 □ 10 □ 100 □ 1000 □

DAMPING **5%**

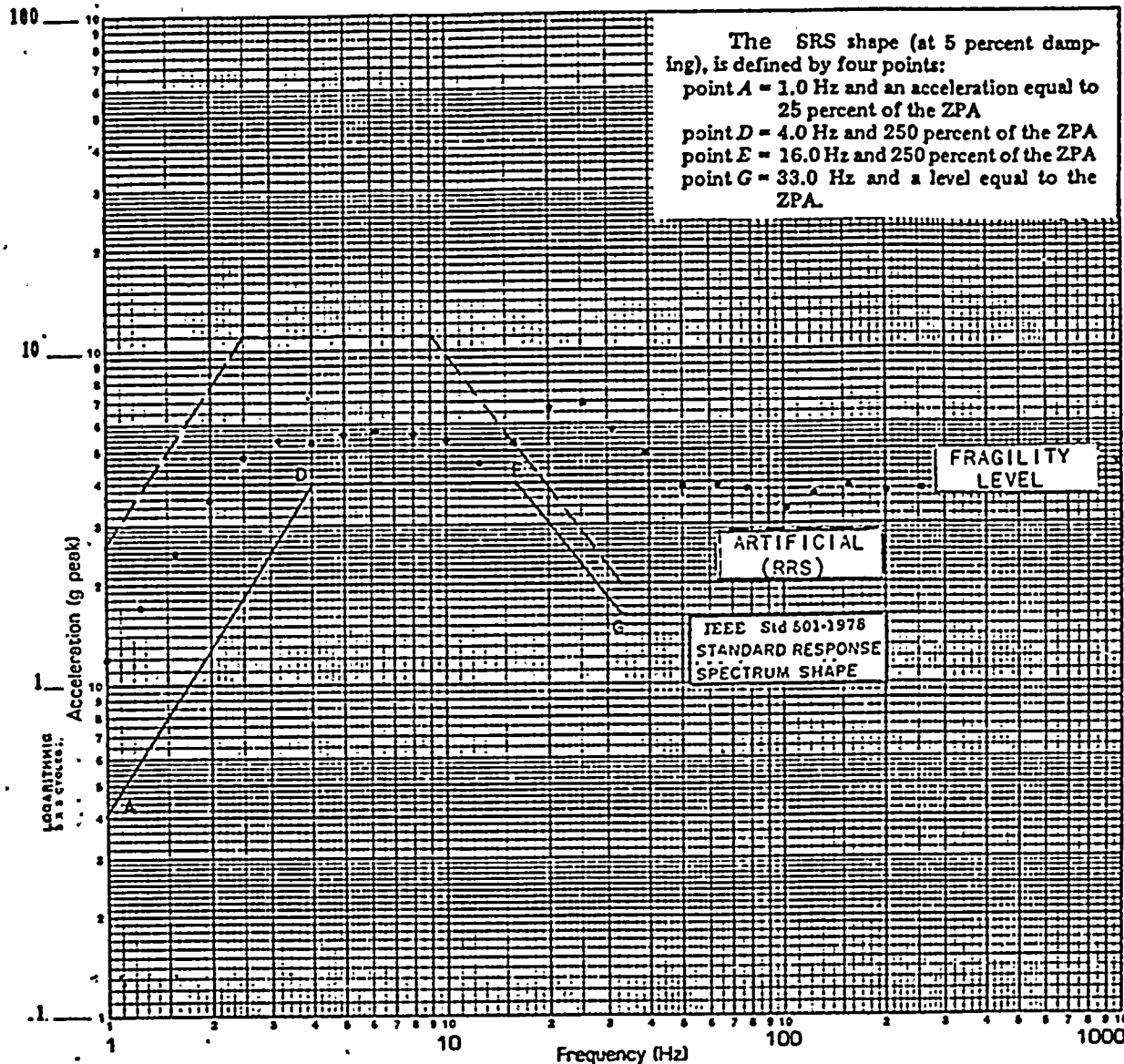

SPECIMEN 2 & 4 (E7022 SERIES) RELAY STATE: TRANSITION MODE (TD X 2)

AXIS \* SEE NOTE (H+V)

TEST RUN NO. 253, 257, (153, 154), (165, 166)

\* COMPOSITE OF FB/V-, SS/V-, SS/V+, FB/V+ X.707 DUE TO 45° INCLINATION OF TEST MACHINE.

Figure 10. Model E7022, Response Spectrum, Transitional Mode



CONTROL PRODUCTS  
DIVISION

AMERACE CORPORATION  
CONTROL PRODUCTS DIVISION  
UNION, N.J. 07083

DOCUMENT NO. E7012/E7022

REV. D

SHEET 18 OF 22

- (a) The standard response spectrum (SRS) for relays per IEEE STD. 501-1978, which gives a specific zero period acceleration "G" level for each of the relay states
- (b) The required response spectrum (RRS), which was used as a guideline and was artificially created by Control Products Division as a goal or maximum test level.

5.4.3 Seismic Test Description. The test machine was inclined at 45-degrees to the horizontal plane to simulate two-axes excitation. In order to orient the test articles to their normal in-service position, they were placed on a 45-degree rigid test fixture. This arrangement gave the input motion equal vectors in the vertical plane and in one horizontal direction. The relays were tested in four horizontal orientations. This was done to test for the in-phase and out-of-phase conditions of the test items. This method of test input is recognized as an acceptable alternative to true biaxial excitation in Section 6.6.6 of IEEE STD. 344-1975.

5.4.4 Failure Criteria. (Class 1E functions monitored during Seismic Tests.)

- (a) Non-Operating Mode. (Relay coils deenergized).

Normally closed contacts monitored for chatter in excess of 1 millisecond with 28 vdc at 1 ampere applied to contacts. Normally open contacts monitored for false transfer of 1 millisecond or greater with 28 vdc at 1 ampere applied to contacts.

- (b) Operate Mode. (Relay coils energized)

Normally open contact monitored for chatter in excess of 1 millisecond with 28 vdc at 1 ampere applied to contacts. Normally closed contacts monitored for false transfer of 1 millisecond or greater with 28 vdc at 1 ampere applied to contacts.

- (c) Transitional Mode. (Relays operated for time delay)

Failure of the relays to timeout twice. Relays set for approximately 10 second time delay.

NOTE

Nominal rated voltage less 10% applied to relay coils during operate and transitional mode tests.



CONTROL PRODUCTS  
DIVISION

AMERACE CORPORATION  
CONTROL PRODUCTS DIVISION  
UNION, N.J. 07083

DOCUMENT NO. E7012/E7022

REV. D

SHEET 19 OF 22

5.4.5 Fragility Level. (Model E7022 only) Device fragility level was obtained in the following manner: Using the Failure Criteria described in paragraph 5.4.4, all relays were first subjected to the artificial RRS acceleration level. If a relay failed to meet its Class 1E function, the testing was continued, but at regressive increments (of approximately 10% levels) until the malfunction ceased. The level at which fault free operation of the relay had been established was documented as the fragility level of that relay.

5.4.6 Test Response. The test responses which exceed the artificial RRS level (and are stated as such) are not the device fragility levels but are highest values tested to.

## 6.0 DESIGN LIFE. (Non-Nuclear)

The relays are actually designed to perform under the conditions given in the following paragraphs.

### 6.1 TEMPERATURE RANGE.

- (a) Operating temperature range is  $-20^{\circ}\text{F}$  to  $+165^{\circ}\text{F}$
- (b) Storage temperature range is  $-67^{\circ}\text{F}$  to  $+165^{\circ}\text{F}$

**NOTE**

The maximum shift in the average of three consecutive time delays taken at  $+77^{\circ}\text{F}$  is  $-20\%$  at  $-20^{\circ}\text{F}$  and  $+20\%$  at  $+165^{\circ}\text{F}$ .

### 6.2 REPEAT ACCURACY.

6.2.1 Repeat Accuracy at any fixed temperature is;

- (a)  $\pm 5\%$  for time delays of 200 seconds or less.
- (b)  $\pm 10\%$  for time delays of 200 seconds or greater.

**NOTE**

The first time delays afforded by Model E7012 relays with "H" (3-30 min.) and "I" (6-60 min.) time ranges will be approximately 15% longer than subsequent delays due to coil temperature rise..

### 6.3 COIL VOLTAGE.

6.3.1 All coils may be operated on intermittent duty cycles at voltages 10% above listed maximums. (Intermittent duty = Maximum 50% duty cycle and 30 minutes "ON" time.

### 6.4 CONTACT RATINGS.



**CONTROL PRODUCTS  
DIVISION**

AMERACE CORPORATION  
CONTROL PRODUCTS DIVISION  
UNION, N.J. 07083

DOCUMENT NO. E7012/E7022

REV. D

SHEET 20 OF 22

6.4.1 Contact Capacity. in Amperes. (Resistive Loads)

CONTACT VOLTAGE	MIN. 100,000 OPERATIONS	MIN. 1,000,000 OPERATIONS
30 vdc	15.0	7.0
110 vdc	1.0	0.5
120 vac, 60 Hz	20.0	15.0
240 vac, 60 Hz	20.0	15.0
480 vac, 60 Hz	12.0	10.0

6.4.2 Contact Ratings, UL.

Contact ratings as listed under the Underwriters Lab. component recognition program for 100,000 operations;

10 Amps, Resistive, 240 vac  
1/4 Horsepower, 120 vac/240 vac

15 Amps, 30 vdc  
5 Amps, General purpose, 600 vac

Per Pole

7.0 QUALITY ASSURANCE PROVISIONS.

7.1 PROJECTED QUALIFIED LIFE.

7.1.1 Ten (10) years from date of manufacture or 25,000 operations, whichever occurs first. (This statement does not alter in any way the warranty on the relay.)

7.2 MAINTENANCE SCHEDULE.

7.2.1 Replacement of the device after 25,000 operations or 10 years from date of manufacture, or before.

7.2.2 The date of manufacture can be found in the first four digits of the serial number which is located on the nameplate. The date code used is a four digit number reflecting year and week of manufacture.

First two digits indicate year     \*\*      
Second two digits indicate week     \*\*    

EXAMPLE: Date code 7814; 78 indicates 1978, 14 indicates week of April 3 thru 7 as year and week of manufacture.

MODEL E7022PC001
COIL 125VDC SERIAL 7814****
TIME 1.5 TO 15 SEC.
11 12



CONTROL PRODUCTS  
DIVISION

AMERACE CORPORATION  
CONTROL PRODUCTS DIVISION  
UNION, N.J. 07083

DOCUMENT NO. E7012/E7022

REV. D

SHEET 21 OF 22

7.2.3 No field repairs or modifications are allowed. A complete relay must be ordered where spares are required.

### 7.3 QUALITY ASSURANCE.

7.3.1 Quality Assurance Program. Agastat<sup>®</sup> devices are built and controlled through an established quality assurance program which is in accordance with the applicable requirements of ANSI N45.2-1977; 10CFR21; and 10CFR50, Appendix B.

7.3.2 Traceability Records. Device traceability records will be maintained by CTP for a period of 11 years from the date of manufacture.

7.3.3 Configuration Control. The configuration code (See Figure 1) is a suffix to the model number and provides a means of identification and configuration control. When a Class 1 change is processed on the product, the configuration code will advance (-001 to -002, etc.) and this specification will be revised if necessary.

### 7.4 QUALIFICATION TEST REPORT, ES1000.

7.4.1 The actual qualification test report, from which the data presented in this specification has been derived, can be obtained from Control Products Division of Amerace Corp. by ordering Test Report Number ES1000.

### 8.0 CONFIGURATION CODE.

8.1 Configuration Code 001. All information in the base document E7012/E7022 and base document ES1000 applies to configuration code 001.

8.2 Configuration Code 002. Material revision to elastomer gasket provides improved thermal aging properties over the 001 configuration. All information in the base document E7012/E7022 and base document ES1000 applies to configuration code 002.



CONTROL PRODUCTS  
DIVISION

Amerace Corporation Control Products Division 2330 Vauxhall Road Union, New Jersey 07083

Telex 138-978



CONTROL PRODUCTS  
DIVISION

AMERACE CORPORATION  
CONTROL PRODUCTS DIVISION  
UNION, N. J. 07083

DOCUMENT NO. E7012/E7022

REV. E

SHEET 22 OF 22

