

REGULATORY INFORMATION DISTRIBUTION SYSTEM (RIDS)

ACCESSION: NBR: 8109020263 DOC. DATE: 81/08/28 NOTARIZED: YES DOCKET #
 FACIL: STN-50-528 Palo Verde Nuclear Station, Unit 1, Arizona Public 05000528
 STN-50-529 Palo Verde Nuclear Station, Unit 2, Arizona Public 05000529
 STN-50-530 Palo Verde Nuclear Station, Unit 3, Arizona Public 05000530
 AUTH. NAME: AUTHOR AFFILIATION
 VAN BRUNT, E. E. Arizona Public Service Co.
 RECIP. NAME: RECIPIENT AFFILIATION
 TEDESCO, R. L. Assistant Director for Licensing

SUBJECT: Forwards responses to balance of plant questions & CESSAR questions. Responses will be incorporated into future FSAR amend. One oversize drawing encl. aperture card will be available in PDR.

See Rpts
 DISTRIBUTION CODE: B0018 COPIES RECEIVED: LTR 1 ENCL 1 SIZE: 119
 TITLE: PSAR/FSAR AMDTS and Related Correspondence

NOTES: Standardized Plant: 1 cy: C: Grimes 05000528
 Standardized Plant: 1 cy: C: Grimes 05000529
 Standardized Plant: 1 cy: C: Grimes 05000530

ACTION:	RECIPIENT	COPIES		RECIPIENT	COPIES	
	ID CODE/NAME	L	E	ID CODE/NAME	L	E
ACTION:	A/D LICENSNG	1	0	LIC BR #3 BC	1	0
	LIC BR #3 LA	1	0	KERRIGAN, J. 04	1	1
INTERNAL:	ACCID EVAL BR26	1	1	AUX SYS BR 27	1	1
	CHEM ENG BR 11	1	1	CONT SYS BR 09	1	1
	CORE PERF BR 10	1	1	EFF TR SYS BR12	1	1
	EMRG PRP DEV 35	1	1	EMRG PRP LIC 36	3	3
	EQUIP QUAL BR13	3	3	FEMA-REP DIV 39	1	1
	GEOSCIENCES 28	2	2	HUM FACT ENG 40	1	1
	HYD/GEO BR 30	2	2	I&C SYS BR 16	1	1
	I&E 06	3	3	LIC GUID BR 33	1	1
	LIC QUAL BR 32	1	1	MATL ENG BR 17	1	1
	MECH ENG BR 18	1	1	MPA	1	0
	O&L 0	1	0	OP LIC BR 34	1	1
	POWER SYS BR 19	1	1	PROC/TST REV 20	1	1
	QA BR 21	1	1	RAD ASSESS BR22	1	1
	REAC SYS BR 23	1	1	<u>REG FILE</u> 01	1	1
	SIT ANAL BR 24	1	1	STRUCT ENG BR25	1	1
EXTERNAL:	ACRS 41	16	16	LPDR 03	1	1
	NRC PDR 02	1	1	NSIC 05	1	1
	NTIS	1	1			

A/A 4

SEP 9 1981

TOTAL NUMBER OF COPIES REQUIRED: LTR

63 ENCL 58
~~62~~ ~~57~~

ARIZONA



PUBLIC SERVICE COMPANY

STA. _____

P.O. BOX 21666 - PHOENIX, ARIZONA 85036

August 28, 1981

ANPP-18786 - JMA/TFQ

cc: J. Kerrigan (w/a)
P. Hourihan (w/a)
A. C. Gehr (w/a)

Mr. R. L. Tedesco
Assistant Director for Licensing
Division of Licensing
Office of Nuclear Reactor Regulation
U.S. Nuclear Regulatory Commission
Washington, D.C. 20555

Subject: Palo Verde Nuclear Generating Station
(PVNGS) Units 1, 2 and 3
Docket Nos. STN-50-528/529/530
File: 81-056-026; G.1.10



Reference: Letter from R. L. Tedesco, NRC, to E. E. Van Brunt, Jr.
dated June 22, 1981, subject: Request for Additional
Information - PVNGS (Reactor Systems Branch)

Dear Mr. Tedesco:

The referenced letter transmitted 85 questions from your RSB, and you asked us to address those which concerned the PVNGS Balance-of-Plant (BOP), with the remaining questions to be addressed on the CESSAR docket (No. STN 50-470). Attached for your use are our responses to all of the BOP related questions which include the following:

440.3	.10	.19	.25	.72	.80	.85
.6	.11	.21	.26	.76	.81	
.7	.14	.22	.30	.77	.82	
.8	.15	.23	.31	.78	.83	
.9	.16	.24	.34	.79	.84	

Also, we have attached our responses to CESSAR Docket questions 440.77 and 440.82. We propose, for clarity, that these be considered 440.86 and 440.87 for the PVNGS dockets. These APS responses will be incorporated into the FSAR in a future amendment.

Please contact me if you have any further questions on these matters.

Very truly yours,

E. E. Van Brunt, Jr.
APS Vice President,
Nuclear Projects
ANPP Project Director

*Boo
5/11*

8109020263 810828
PDR ADDCK 05000528
A PDR

EEVBJr/TFQ/av
Attachment

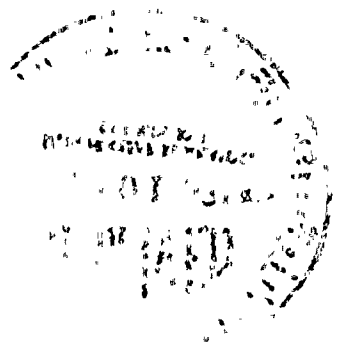

STATE OF ARIZONA)
) ss.
COUNTY OF MARICOPA)

I, Edwin E. Van Brunt, Jr., represent that I am Vice President Nuclear Projects of Arizona Public Service Company, that the foregoing document has been signed by me on behalf of Arizona Public Service Company with full authority so to do, that I have read such document and know its contents, and that to the best of my knowledge and belief, the statements made therein are true.



Edwin E. Van Brunt, Jr.

Sworn to before me this 26th day of AUGUST, 1981.

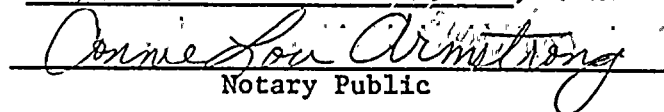

Notary Public

My Commission expires:

June 24, 1983



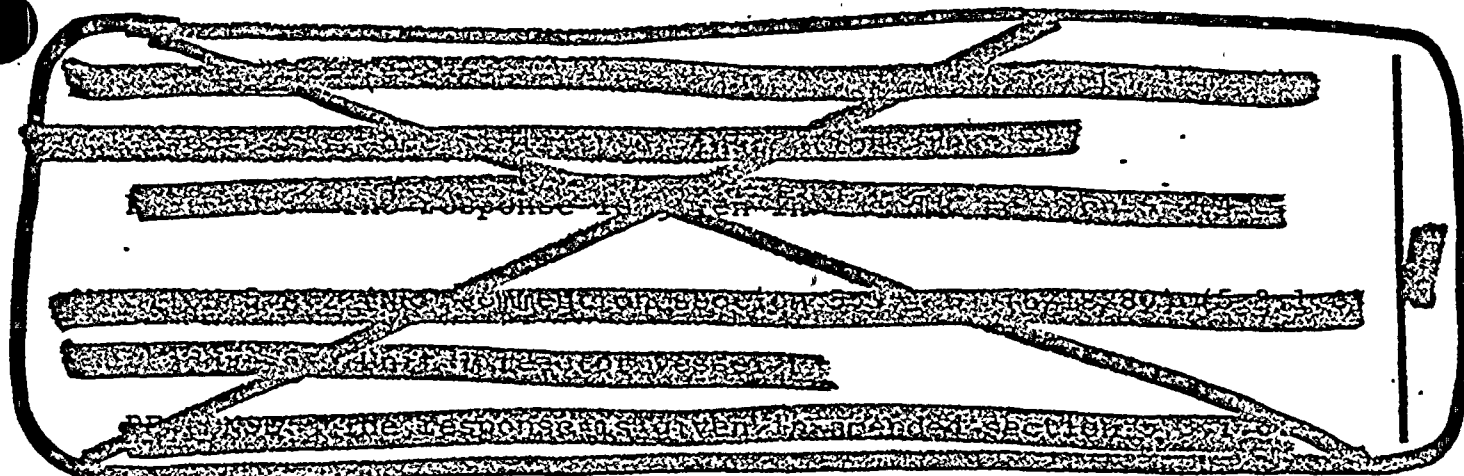

QUESTION 5A.3 (NRC Question 440.1) ✓

(5.2.2)

A description of the design features which will be used to mitigate the consequences of overpressurization events while operating at low temperatures is not provided in the CESSAR System 80 FSAR. Provide a description of the features which will be provided on the CESSAR System 80. Specific design criteria regarding overpressurization protection while operating at low temperatures are as follows:

1. Operator Action: No credit can be taken for operator action for 10 minutes after the operator is aware of a transient.
2. Single Failure: The system must be designed to relieve the pressure transient given a single failure in addition to the failure that initiated the pressure transient.
3. Testability: The system must be testable on a periodic basis consistent with the system's employment.
4. Seismic and IEEE 279 Criteria: Ideally, the system should meet seismic Category 1 and IEEE 279 criteria. The basic objective is that the system should not be vulnerable to a common failure that would both initiate a pressure transient

6

8109020263



and disable the overpressure mitigating system. Such events as loss of instrument air and loss of offsite power must be considered.

An alarm must be provided to monitor the position of the pressurizer relief valve isolation valves to assure that the overpressure mitigating system is properly aligned for shutdown conditions.

In demonstrating that the mitigation system meets these criteria, the applicant should include the following information in his submittal:

1. Identify and justify the most limiting pressure transients caused by mass input and heat input.
2. Show that overpressure protection is provided (do not violate Appendix G limits) over the range of conditions applicable to shutdown/heatup operation.
3. Identify and justify that the equipment will meet pertinent parameters assumed in the analyses (e.g., valve opening times, signal delay, valve capacity).
4. Provide a description of the system including relevant P&I drawings.
5. Discuss how the system meets the criteria.
6. Discuss all administrative controls required to implement the protection system.

RESPONSE: The response will be provided on the CESSAR docket.



QUESTION 5A.4 (NRC Question 440.2) ✓ (5.2.2)

Provide details of your proposed preoperational and initial startup test program to show that they are consistent with the requirements of Regulatory Guide 1.68.

RESPONSE: *The response will be provided on the CESSAR docket for those tests in the CESSAR scope. For remaining tests not in CESSAR scope, the response is provided in sections 1.8 and 14.B.11.*

QUESTION 5A.5 (NRC Question 440.3) ✓ (5.2.2)

Check valves in the discharge side of the high pressure safety injection, low pressure safety injection, RHR, and charging systems perform an isolation function in that they protect low pressure systems from full reactor pressure. The staff will require that these check valves be classified ASME IWV-2000 Category AC, with the leak testing for this class of valve being performed to code specifications. It should be noted that a testing program which simply draws a suction on the low pressure side of the outermost check valves will not be acceptable. This only verifies that one of the series check valves is fulfilling an isolation function. The necessary frequency will be that specified in the ASME Code, except in cases where only one or two check valves separate high to low pressure systems. In these cases, leak testing will be performed at each refueling after the valves have been exercised: Identify all check valves which should be classified Category AC as per the position discussed above. Verify that you have the necessary test lines to leak test each valve. Provide the leak detection criteria that will be in the Technical Specifications.

RESPONSE: The following ^{check} valves are classified Category AC as described above:

- Safety Injection (SI) Valves V-
 - , 215, 217, 225, 227, 235, 237, 245, 247, 540,
 - 541, 542 and 543
 - 522, 523, 532, 533*

The response will be provided on the CESSAR docket for check valves classified Category AC, which are leak tested. The PVNGS design differences from the CESSAR design modifies the list as follows:

September, 1981

5A-3
07-28-81

Amendment 6.

6

16



, as shown in figure 6.3-1,

Adequate test connections and lines have been provided to facilitate testing of the above listed valves to ASME IWV-2000, Category AC requirements. The leak detection criteria ^{of 1 gal/min} will be included in the Technical Specifications.

QUESTION 5A.6 (NRC Question 440.4) ✓ (5A)

On page 5A-2, it is indicated that a negative Doppler coefficient of -0.8×10^{-5} ^{$\Delta K/K/F$} ~~$\Delta K/K/F$~~ is assumed in the bounding overpressure transient (loss of load). It is our position that overpressure protection of system be demonstrated without taken credit for either doppler or moderator temperature reactivity feedback (SRP 5.2.2, Section III.6). Reanalyze the bounding overpressure transient without credit for doppler feedback, demonstrating that primary system pressure does not exceed 110% of the design pressure.

RESPONSE: The response will be provided on the CESSAR docket.

QUESTION 5A.7 (NRC Question 440.5) ✓ (5A)

On page 5A-1, it is indicated that the worst case transient, loss of load, in conjunction with a delayed reactor trip, is the design basis for the primary safety valves. It is our position that the high pressure reactor ^{trip} or second safety grade trip signal, whichever occurs later, should be used for sizing the primary system safety valves. Confirm that the CESSAR System 80 safety valves are sized sufficiently to accommodate a reactor trip on the second safety grade trip signal.

RESPONSE: The response will be provided on the CESSAR docket.

Palo Verde must have the capability to take the plant from full power to a cold shutdown using only safety grade equipment, per the requirements of BTP RSB 5-1. Address your compliance with all provisions of that position and respond to the detailed question below.

Question 1. Describe the sequence for achieving a cold shutdown condition within 36 hours, assuming the most limiting single failure with only onsite power availability. Identify all manual actions inside or outside containment that must be performed and discuss the capability of remaining at hot standby until manual actions (or repairs) can be performed.

Question *1.a* 1a. If the steam generator dump valves, operators, air and power supplies are not safety grade, justify how you would cool down the primary system in the event of loss of offsite power and an SSE.

Question *1.b* 1b. Describe the sequence for depressurizing the primary system using only safety-grade systems, assuming a single failure. Identify all manual actions inside or outside containment that must be performed.

Question *1.c* 1c. Discuss the boration capability using only safety-grade systems, assuming a single failure. Identify all manual actions inside or outside containment that must be performed. If the proposed boration method utilizes the charging pumps (assuming a letdown line failure is proposed), provide an evaluation



of this approach with regard to concentration of boron source and liquid volume in primary system.

- Question 2. Discuss the provisions for collection and containment of RHR pressure relief valves discharge.
- Question 3. Describe tests which will demonstrate adequate mixing of the added borated water and cooldown under natural circulation conditions with and without a single failure of a steam generator atmospheric dump valve. Specific procedures for plant cooldown under natural circulation conditions must be available to the operator. Summarize these procedures.
- Question 4. Discuss the availability of the Seismic Category I auxiliary feedwater supply for at least 4 hours at hot shutdown plus cooldown to the RHR system cut-in based on longest time for the availability of only onsite or only offsite power and assuming a single failure. If this cannot be achieved, discuss the availability of an adequate alternate Seismic Category I water source.
- Question 5. What provisions in natural circulation cooldown methods have been made to account for possible upper head void formation?

RESPONSE:

GROUP 1, 1a. The response will be provided on the CESSAR docket. Additional clarification is provided as follows.

INSERT A →



Each tank can be isolated or vented from the control room.

- As a backup to the ^{normal} instrument air system,
1. a. PVNGS provides a safety grade nitrogen system to operate the steam generator atmospheric dump valves ^(ADV's). The system provides nitrogen supply for 8 hours of operation of these valves. One nitrogen accumulator is provided for each ADV. A single failure will not result in loss of capability to vent the minimum required amount of steam necessary for decay heat removal and plant cooldown.
 1. b. ~~As discussed in~~ The response to NRC Question 440.9 discusses power lockout for the safety injection tank (SIT) vent and isolation valves. Additionally, power can be restored to the SIT vent valves from the control room to depressurize the SITs. There is no single failure which could result in the opening of all SIT ~~isolation~~ valves or could preclude RCS depressurization.
 2. RHR pressure relief discharge piping is provided with a sparger that is located at the bottom of the ^{containment emergency} sump. On that basis, no direct steam flow would be directed toward any personnel.
 1. c. As stated in section 9.3.4.1, the charging pumps are not automatically sequenced onto the emergency buses. The charging pumps can be loaded onto the emergency buses from the control room.
 4. The condensate storage tank is discussed in section 9.2.6. The tank is designed to provide sufficient auxiliary feedwater supply for 8 hours at hot standby ^{including} and cooldown to RHR initiation at 350F. A single failure ~~of pumps, valves, or piping~~ will not result in loss of water supply such that cooling to RHR initiation cannot be achieved. Pumps, valves, and piping required for essential operation are redundant, separated, and protected from adverse environmental effects.



PYNGS meets C-E's interface requirements for a water volume of 300,000 gallons and additionally provides a 10 percent margin for a total supply of 330,000 gallons. Additional non-Seismic Category I supplies are provided. These consist of a 125,000 gallon demineralized water storage tank at each unit, a 125,000 gallon demineralized water tank shared by all 3 units, a 600 gal/min makeup demineralized water flow, and a 550,000 gallon reactor makeup water tank at each unit which can be manually aligned to provide water to the auxiliary feedwater system.



QUESTION 5A.9 (NRC Question 440.7) ✓

(5.4.7)

Provide detailed information on the sizing criteria used to determine the relief capacity of the SDCS suction line pressure relief valves.

Did the version of the ASME code that the SDCS relief valves were sized to require establishing liquid or two-phase relief capacity with testing? If so, describe in detail the test program and results. If the liquid or two-phase relief capacity was not established by test, show that the difference between the rated and maximum required relief capacity is more than sufficient to bound liquid and two-phase relief rate uncertainties.

Provide details on the alarms and indications which would inform the operators that a SDC suction line isolation valve has closed while the plant is in shutdown cooling. Is there any common failure which would result in both valves being closed while in shutdown cooling.

6

When LPSI pump mini flow isolation valves are closed during shutdown cooling, what would prevent pump damage if a pressure transient were to occur which caused RCS pressure to exceed LPSI deadhead pressure.

When the plant is in the SDCS mode, is there any single failure which could cause the suction of both SDC pumps to be switched from the hot leg piping to the dry sumps?

RESPONSE:

[Redacted response text consisting of four horizontal bars, circled in black with a handwritten flourish above it.]

INSERT B →



Detailed information on relief valve sizing criteria and ASME code requirements will be provided on the CESSAR docket. In addition, interlocks supplied by independent power supplies are provided to isolate the low pressure portion of the shutdown cooling system.

Alarms and indications which would inform ^{the} operators that a SDC suction line isolation valve has closed are shown in Figure 6.3-1. The figure identifies train A SDC isolation valves SI-UV651, 653, and 655 and train B SDC isolation valves SI-UV652, 654, and 656 as having control room position indication. The figure also shows that pressure, temperature, and flow indication is provided in the control room. This information can be used to inform the operators that a SDC suction line isolation valve has closed while the plant is in shutdown cooling mode. As discussed in the response to NRC Question 440.10, train A valves are completely independent from train B valves, each train providing a redundant parallel shutdown cooling path. In addition, each train consists of ^{3 valves} ~~two valves~~ in series powered. Therefore, no single or common failure can result in loss of shutdown cooling capability, either due to failure of a valve to open or failure of a valve to close.

from two separate channels.

A discussion of LPSI pump mini flow isolation valves and potential to switch suction of SDC pumps from hot leg piping to dry sumps, ~~is~~ provided on the CESSAR docket. will be



QUESTION 5A.10 (NRC Question 440.8) ✓

(5.4.7)

Provide the following information related to pipe breaks or leaks in high or moderate energy lines outside containment associated with the RHR system when the plant is in a shutdown cooling mode:

1. Determine the maximum discharge rate from a pipe break in the systems outside containment used to maintain core cooling.
2. Determine the time available for recovery based on these discharge rates and their effect on core cooling.
3. Describe the alarms available to alert the operator to the event, the recovery procedures to be utilized by the operator, and the time available for operator action.

A single failure criterion consistent with Standard Review Plan 3.6.1 and Branch Technical Position APCS 3-1 should be applied in the evaluation of the recovery procedures utilized.

RESPONSE:

← INSERT A

~~The maximum discharge rate from a pipe break in the systems outside containment used to maintain core cooling would be from a pipe break on a shutdown cooling heat exchanger (SDCH) discharge line at each SDCH room on the seventh floor level of the Auxiliary Building. The flooding level for 30 minutes is 8.9 feet. This is a conservative estimate of flow from the room and drainage.~~

~~The maximum flooding was assumed to last for 30 minutes for the purpose of obtaining worst case conditions. During a flooding event, the leak would be detected by the level alarm in the room and drains. This would allow time to be repaired before the~~



INSERT A to page 5A-6

1. In accordance with NRC Branch Technical Position MEB 3-1 for a moderate energy system, the largest crack is based on a circular opening whose area is equal to a rectangle one-half pipe diameter in length and one-half pipe wall thickness in width. The maximum discharge rate was calculated to be 990 gal/min based on the upper limits of 275 psig and 200F for a moderate energy system. The rate is further maximized using a 2.375 sq. in. crack in the shutdown cooling heat exchanger (SDCHX) discharge line since this line is a 20-inch line. The crack location is in the SDCHX room on the 70 foot level of the auxiliary building.



2. Assuming no operator action for 30 minutes, even at this maximum discharge rate there would be no adverse effect on core cooling as the redundant train can provide full heat removal capability and sufficient RCS inventory will exist. The water level will be well above the midpoint of the RCS hot leg.

3. Alarms are provided in the control room on high level in the floor drain sump and low pressurizer level. Either alarm will alert the operator of a leak. The floor drain sump alarm will assist the operator in locating the affected train which he can then isolate. These actions will take place within 30 minutes of the first alarm.



Indicate whether there are any systems or components needed for shutdown cooling which are de-energized or have power locked out during plant operation. If so, indicate what actions have to be taken to restore operability to the components or systems.

It is the staff's position that all operator actions necessary to take the plant from normal operation to cold shutdown (SDCS entry) should be performed from the control room. If the present design does not meet this position, please commit to revise it accordingly.

RESPONSE: *The response will be provided on*
~~the CESSAR docket.~~
the CESSAR docket.

~~Response is as follows:~~
~~The equipment needed includes:~~
~~1. Shutdown cooling pumps~~
~~2. Auxiliary shutdown pumps~~
~~3. Essential cooling pumps near emergency~~
~~4. Essential shutdown pumps~~
~~5. Essential shutdown pumps and pumps~~
~~6. Shutdown cooling pumps may be operated from the~~
~~room.~~

6



QUESTION 5A.12 (NRC Question 440.10) ✓

(5.4.7)

Provide additional information regarding the power sources supplied to the SDCS isolation valves. The staff's position is that a single failure of a power supply will not prevent isolation of the SDCS when RCS pressure exceeds its design pressure. Additionally loss of a single power supply cannot result in the inability to initiate at least one 100 percent shutdown cooling train.

RESPONSE:

~~The response will be provided on the CESSAR docket.~~

~~Additionally,~~
The power supply to the shutdown cooling isolation valves is given below. Valve arrangement is shown on figure 6.3-1.

- ← Train A: UV-655 (Note 1)
UV-653 (Note 3)
UV-651 (Note 1)
- Train B: UV-656 (Note 2)
UV-654 (Note 4)
UV-652 (Note 2)

[PAGE
5A-7]

NOTES:

1. Fed from ^{Train A} Class IE MCC E-PHA-M35
2. Fed from ^{Train B} Class IE MCC E-PHB-M36
3. Fed from Class IE Channel C battery through Class IE Inverter E-PKC-N43
4. Fed from Class IE Channel D battery through Class IE Inverter E-PKD-N44

[PAGE
5A-8]

~~_____~~
INSERT B →



The power supplies indicated provide power to the valve operator (motor). Train A valves are completely independent from train B valves, each train providing a redundant parallel shutdown cooling path. Each train consists of ~~two~~ 3 valves ~~in series~~ in series. Therefore, no single or common failure can result in loss of shutdown cooling capability, either due to a failure of a valve to open or failure of a valve to close. Thus PVNGS meets the single failure criterion. ~~...~~

powered from 2 separate channels.



QUESTION 6A.28 (NRC Question 440.11) ✓

(6.3)

Discuss the provisions and precautions for assuring proper system filling and venting of ECCS to minimize the potential for water hammer and air binding. Address piping and pump casing venting provisions and surveillance frequencies.

RESPONSE: The safety injection piping will be maintained filled with water. This will minimize the potential for water hammer. All piping is provided with high point vents and low point drains. The centrifugal pumps are vented through their discharge pipes. The pumps use a casing drain for draining. The containment spray headers will be maintained full up to elevation 115 feet. The safety injection pumps will be tested monthly to satisfy the requirements of ASME XI. To assure a full system, procedures will be developed ensuring proper inspection of key points at sufficient intervals.

6



QUESTION 6A.29 (NRC Question 440.12) ✓

(6.3.3)

Section 6.3.3.2.2 states that the worst single failure for the large break LOCA is the failure of one of the low pressure pumps to start which will result in a minimum amount of safety injection water available to the core. Explain why the single failure of a diesel generator, which results in loss of one HPSI train and one LPSI train, is not the worst single failure for the large break LOCA with respect to the amount of safety injection water available to the core in post LOCA operation.

RESPONSE: The response will be provided on the CESSAR docket.

6



QUESTION 6A.30 (NRC Question 440.13) ✓ (6.3)

Identify all ECCS valves that are required to have power locked out and confirm they are included under the appropriate Technical Specifications, with surveillance requirements listed.

RESPONSE: The response will be provided on the CESSAR docket.

6



QUESTION 6A.31 (NRC Question 440.14) ✓

(6.3)

Consideration should be given to the possibility that local manual valves (handwheel), could go undetected in the wrong position until a postulated accident occurs. Appropriate administrative controls or valve position indication are examples of methods to be considered to minimize this possibility. Provide a list of all critical manual valves and address the actions that will be implemented to assure all critical valves are properly positioned.

Identify all manual valves which have locking provisions.

It is our position that limit switches which enable valve position to be indicated in the control room should be installed on all manually operated and normally locked ECCS valves.

In addition a recent event (Docket 50-320, LER 78-20/3L, 4/21/78) has brought to our attention that the automatic operation of some motor operated valves can be disabled when the manual handwheel pins are engaged. Identify all critical motor operated valves associated with the CESSAR 80 design that have this design feature and describe the controls and procedures utilized to prevent the inadvertent disablement of the automatic operation of these valves.

RESPONSE:

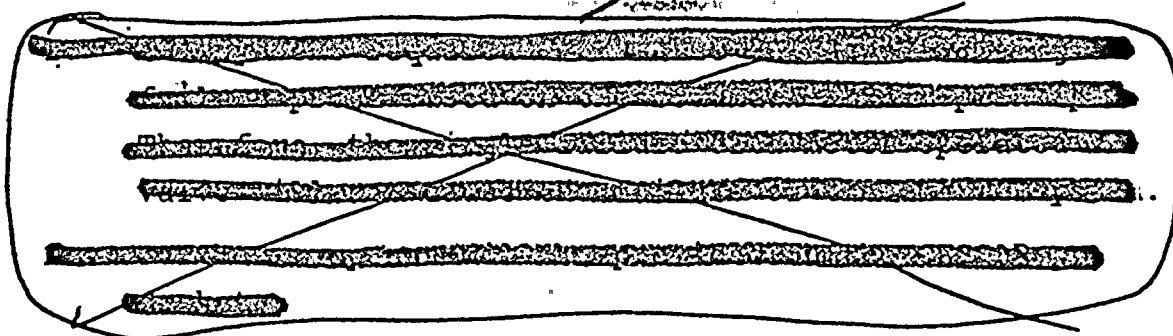

The response will be provided on the CESSAR docket.



QUESTION 6A.32 (NRC Question 440.15) ✓

(6.3)

Identify the plant operating conditions under which certain automatic safety injection signals are blocked to preclude unwanted actuation of these systems. Describe the alarms available to alert the operator to a failure in the primary or secondary system during this phase of operation and the time available to mitigate the consequences of such an accident.

RESPONSE:

 The response will be provided on the CESSAR docket.

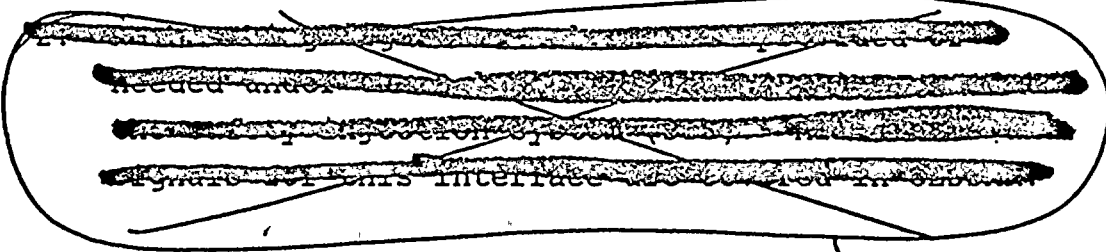

6



QUESTION 6A.33 (NRC Question 440.16) ✓

(6.3)

The information in the CESSAR 80 FSAR regarding post-LOCA passive failures is not complete. It is the Reactor Systems Branch position that detection and alarms be provided to alert the operator to passive ECCS failures during long-term cooling which allow sufficient time to identify and isolate the faulted ECCS line. The leak detection system should meet the following requirements:

1. Identification and justification of maximum leak rate should be provided.
2. Maximum allowable time for operator action should be provided and justified.
3. Demonstration should be provided that the leak detection system will be sensitive enough to initiate (by alarm) operator action, permit identification of the faulted line, and isolation of the line prior to the leak creating undesirable consequences such as flooding of redundant equipment or excessive radioactive fluid. The minimum time to be considered is 30 minutes.
4. It should be shown that the leak detection system can identify the faulted ECCS train and that the leak is isolatable.
5. The leak detection system must meet the following standards:
 - a. Control Room Alarm
 - b. IEEE 279-1971, except single failure requirements

RESPONSE:

INSERT A →

~~The response will be provided in CESSAR.~~
~~The response will be provided in CESSAR.~~

3. The level instrumentation is mounted in each safety injection pump room sump. This provides a high water level alarm in the control room after an accumulation of 3.5 gallons of water in the sump. Each safety



to items 1 and 2

The response is provided in the response to NRC
Question 440.8. In addition, the following additional
information is provided.

items 1 and 2.



injection pump room sump high water level alarm is a IE annunciation in the control room. This level is sufficient to provide isolation of the leak by appropriate operator action within 30 minutes. This action will consist in part of shutting suitable isolation valves to stop the leak. This action will also include steps to isolate the leaking train.

4. The safety injection leak detection system consists of individual level switches in each train pump room. Individual control room IE annunciation windows enable identification of the leaking train. See 6A.18.3 for leak isolation methods.

5. The safety injection leak detection system consists of a IE (safety grade) switch in each pump room for each train of the:

High Pressure Safety Injection Pump

Low Pressure Safety Injection Pump

Containment Spray Pump

Each level switch actuates a IE annunciation in the control room. The train "A" pump rooms are monitored by channel "A" instrumentation powered by ^{Train A} Class IE power. The train "B" pump rooms are monitored by channel "B" instrumentation powered by ^{Train B} Class IE power. The system complies with IEEE Standard 279-1971 except for single failure requirements.

Fuel building exhaust radiation monitors 13-J-SQB-RU-145 and 146 will monitor noble gas releases from the essential filtration units that serve areas subject to leakage from ESF recirculation components and piping. Monitor sensitivities are described in section 11.5 and are adequate to provide early detection of recirculation loop leakage.



QUESTION 6A.34 (NRC Question 440.17) ✓

(6.3)

The acceptance criteria in the Standard Review Plan for Section 6.3 states the ECCS should retain its capability to cool the core in the event of a single active or passive failure during the long-term recirculation cooling phase following an accident. Demonstrate that CESSAR 80 ECCS design has this capability.

RESPONSE: The response will be provided on the CESSAR docket.

6



QUESTION 6A.35 (NRC Question 440.18) ✓

(6.3)

A reported event has raised a question related to the conservatism of NPSH calculations with respect to whether the absolute minimum available NPSH has been considered. In the past, the required NPSH has been taken by the staff as a fixed number supplied through the applicant by either the architect engineer or the pump manufacturer. Since a number of methods exist and the method used can affect the suitability or unsuitability of a particular pump, it is requested that the basis on which the required NPSH was determined be branded (i.e., test, Hydraulic Institute Standards) for all the ECCS pumps and the estimated NPSH variability between similar pumps including the testing inaccuracies be provided.

RESPONSE: The response will be provided on the CESSAR docket.



QUESTION 6A.36 (NRC Question 440.19) ✓

(6.3)

Provide the basis for ECCS lag times. Are these times calculated or verified by test. If calculated, are they verified during preoperational tests, and periodically reverified?

RESPONSE:

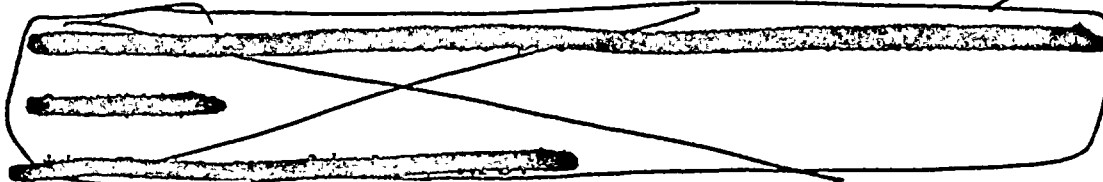

The response will be provided on the CESSAR docket. In addition, PVNGS will verify ECCS lag times during the preoperational testing phase.

6



QUESTION 6A.37 (NRC Question 440.20) ✓

(6.3)

Provide in the Technical Specifications, (1) the range of nitrogen cover gas pressure for the SIT, and (2) the ECCS pump discharge pressures.

RESPONSE: The response will be provided on the CESSAR docket.

6



QUESTION 6A.38 (NRC Question 440.21)✓

(6.3)

Provide a time reference for each action in the sequence of action included in the changeover from injection to recirculation. Indicate the time required to complete each action and what other duties the operator would be responsible for at this point in the accident. How much time does the operator have to assure that the system is realigned to the recirculation mode before RWST water is exhausted if the RWSP isolation valves are not closed? Consider the required pump NPSH in your response.

If the operator fails to close the RWST isolation valves, demonstrate that the HPSI will continue to adequately cool the core during the recirculation mode.

RESPONSE:

The response will be provided on the CESSAR docket.

~~_____~~ Additional information is provided as follows.

~~_____~~

The changeover from the safety injection mode to the recirculation mode occurs automatically upon recirculation actuation signal. The opening time of the containment isolation valves is 20 seconds. After opening of these valves, the operator may close the RWT isolation valves. The closure of the RWT isolation valves ~~is~~ ^{is initiated} manually from the control room. ~~_____~~ Full closure takes 30 seconds. It should be noted that the closure of these valves is not mandatory for proper ECCS performance due to the fact that physical arrangement of the RWT in relation to the ECCS pumps precludes drawing air from the RWT once the containment recirculation valves are open.

INSERT A →



INSERT A to page 6A.3B-1

440.21

The reactor operator will be performing those actions that are required to be performed on the control panels. His actions will be guided by emergency procedures that will indicate what actions are required to be accomplished to correct or restore those parameters to minimize the consequences and severity of the accident.

After preparation of the emergency procedures, PVNGS will perform a walk through of the procedure on its simulator and verify the operator has enough time to complete all required actions.



QUESTION 6A.39 (NRC Question 440.22) ✓

(6.3)

Recently, another plant has indicated that a design error existed in the sizing of their RWST. This error was discovered during a design review of the net positive suction head requirements for the containment spray and residual heat removal pumps. The review showed that there did not appear to be sufficient water in the RWST to complete the transfer of pump suction from the tank to the containment sump, before the tank was drained and ECCS pump damage occurred.

It was reported that in addition to the water volume required for injection following a LOCA, an additional volume of water is required in the RWST to account for:

1. Instrument error in RWST level measurements.
2. Working allowance to assure that normal tank level is sufficiently above the minimum allowable level to assure satisfaction of technical specifications.
3. Transfer allowance so that sufficient water volume is available to supply safety pumps during the time needed to complete the transfer process from injection to recirculation.
4. Single failure of the ECCS system which would result in larger volumes of water being needed for the transfer process. In this situation, the worst single failure appears to be failure of a single ECCS train to realign to the containment sump upon low RWST signal. This result in the continuation of large RWST outflows and reduces the time available for the manual recirculation switchover, before the tank is drawn dry and the operating ECCS pumps are damaged.
5. Unusable volume in the tank is present because once the tank suction pipes are reached, the pumps lose suction and any remaining water is unusable. Additionally, some



amount of water above the suction pipes may also be unusable due to NPSH considerations and vortexing tendencies with the tank.

Preliminary indications are that approximately an additional 100,000 gallons of RWST capacity were needed to account for these considerations. It is our understanding that the design parameters for instrument error, transfer allowance and single failure have changed since the original sizing of the tank.

In light of the above information, discuss the adequacy of your Refueling Water Storage Tank. Provide a discussion of the necessary water volumes to accommodate each of the five considerations indicated above. Justify your choice of volumes necessary to account for each consideration. Provide drawings of your RWST, showing placement and elevation of tank suction lines, and level sensors. Also, provide operator switchover procedures for aligning to the recirculation mode, with estimates of the time required for each action.

INSERT A →

RESPONSE: ~~The RWST is designed to maintain a minimum of 78,870 gallons of water in the tank at all times to ensure adequate margin in the system, which are summarized as follows. The total tank capacity is 122,000 gallons. The holding allowance is 78,870 gallons. Transfer allowance is defined as the time needed to align on any of the four recirculation phases. This has been estimated as 60 seconds, out of which 15 seconds are for valve/instrument operation and 45 seconds are for operator action. For two train operation this corresponds to 3195 gallons.~~



The response will be provided on the CESSAR docket.

The PVNGS design meets the CESSAR interface requirements identified in the CESSAR response.

In addition, for item 5, vortexing tendencies within the tank are precluded by a suction cage inside the tank, similar in design to the cage installed in the containment emergency sump.



QUESTION 6A.40 (NRC Question 440.25) ✓

.23

(6.3)

Provide a discussion on specific methods of detecting, alarming and isolating passive ECCS failures during long-term cooling to include valve leakage. Show that there is sufficient time for the operator to take corrective action and maintain an acceptable water inventory for recirculation. [1] Justify the basis for the assumed leak rates. [2] Describe how the contaminated water would be handled if one ECCS train must continue to operate with a leak.

RESPONSE:

1. The response will be provided on the CESSAR docket. *Additional discussion is provided in the response to NRC Question 440.16.*
2. The leakage from the valves within the auxiliary building ~~will be~~^{is} collected in radwaste sumps at the lowest building elevation of 40 feet. From this point, the waste ~~will~~^{can} be pumped to the liquid radwaste system (LRS) for processing.

Normal valve leakage is considered insignificant when compared to the passive ECCS failure identified in the response to NRC Question 440.16.



QUESTION 6A.41 (NRC Question 440.24) ✓

(6.3)

Assume a maximum passive failure flow rate of 50 GPM in each ECCS pump room and discuss the [1] effects of the passive failure to each ECCS pump operation, and [2] demonstrate that adequate protection is provided for ECCS pumps from possible flooding.

RESPONSE:

The SIS pumps are located at elevation 40 feet of the Auxiliary Building. Each pump is housed in a separate Seismic Category I reinforced concrete compartment. The leakage within each compartment is routed to ^{one of} two separate train-related sumps. Each sump has its own pump. The embedded drain piping from each pump room to the respective sump is built to ASME Section III, Class 3 requirements. Each sump pump is capable of pumping 50 gal/min. Therefore, there are no harmful effects to ECCS pump operation.

6



QUESTION 6A.42 (NRC Question 440.25)

(6.3)

In the event of early manual reset of the safety injection actuation signal (SIAS) followed by a loss of offsite power during the injection phase, operator action may be required to reposition ECCS valves and restart some pumps. The staff requires that operating procedures specify SIAS manual reset not be permitted for a minimum of 10 minutes after a LOCA. Provide the administrative procedures to ensure correct load application to the diesel generators in the event of loss of offsite power following an SIAS reset.

RESPONSE:

[REDACTED]

[REDACTED]

[REDACTED]

The SIAS can only be reset when the initiating parameters have cleared. If SIAS were reset, then the conditions would have been restored to normal and the safety injection system would not be in the injection mode but the safety injection pumps would continue to operate until individually shut off by the operator.

The PVNGS procedures will provide sufficient information so that the operator can take the proper action to restore the plant to a safe condition. A SIAS will not be reset unless the operator has determined that conditions warrant this action. In addition, operating procedures will specify that SIAS manual reset not be permitted for a minimum of 10 minutes after a LOCA.

Additionally, procedures will be provided to cover operation of the diesel generators. These procedures will ensure that the diesels are correctly loaded, including during the event of loss of offsite power following a SIAS reset.



QUESTION 6A.43 (NRC Question 440.26) ✓

(6.3)

Describe the instrumentation for level indication in the containment emergency sump. Also, provide detailed design drawings of the containment emergency sump including the design provisions which preclude the formation of air entraining vortices during recirculation cooling. Confirm that the containment emergency sump design meets the requirements of Regulatory Guide 1.82.

RESPONSE: Containment level instrumentation is provided to ensure there is sufficient net positive suction head (NPSH) for the safety injection pumps and to verify that essential equipment is not flooded. The range provided is from plus 6 inches above the sumps to plus 6 inches above the maximum flood level. A total range of eleven feet is provided in the control room. This safety-grade instrumentation is redundant, physically separated, environmentally qualified to post-LOCA environment, seismically qualified to function during and following a safe shutdown earthquake (SSE) and powered from redundant Class IE sources. The containment emergency sumps and screens are designed in full compliance with NRC Regulatory Guide 1.82, Revision 0. The sumps hydraulic performance was tested on a one-to-one^{scale} model in a hydraulic laboratory. As a result of the tests, a special vortex breaking cage will be installed^{around} the safety injection sump suction line inside each sump. The tests have shown that the hydraulic performance of the sump is satisfactory with the vortex breaking cage installed. Further information on the model study is contained in the transcript to the Containment Systems Independent Design Review submitted under PVNGS transmittal letter ANPP-18147, dated June 4, 1981.

This range is above the minimum level for NPSH requirements.



QUESTION 6A.44 (NRC Question 440.27) ✓

(6.3)

Recent plant experience has identified a potential problem regarding the operability of the pumps used for long-term cooling (normal and post-LOCA) for the time period required to fulfill that function. Provide the pump design lifetime (including operational testing) and compare to the continuous pump operational time required during the short- and long-term of a LOCA. Submit information in the form of tests or operating experience to verify that these pumps will satisfy long-term requirements.

RESPONSE: The response will be provided on the CESSAR docket.

6



QUESTION 6A.45 (NRC Question 440.28) ✓

(6.3)

Describe the means provided for ECCS pump protection including instrumentation and alarms available to indicate degradation of ECCS pump performance. Our position is that suitable means should be provided to alert the operator to possible degradation of ECCS pump performance. All instrumentation associated with monitoring the ECCS pump performance should be operable without offsite power, and should be able to detect conditions of low discharge flow.

RESPONSE: The response will be provided on the CESSAR docket.

6



QUESTION 6A.46 (NRC Question 440.29) ✓

(6.3)

Describe the instrumentation available for monitoring ECCS performance during post-LOCA operation (injection mode and recirculation mode).

RESPONSE: The response will be provided on the CESSAR docket.

6



QUESTION 6A.47 (NRC Question 440.30) ✓

(6.3)

Provide a commitment that Palo Verde will perform preoperational and startup tests to meet the requirements of Regulatory Guide 1.68 and 1.79.

RESPONSE:

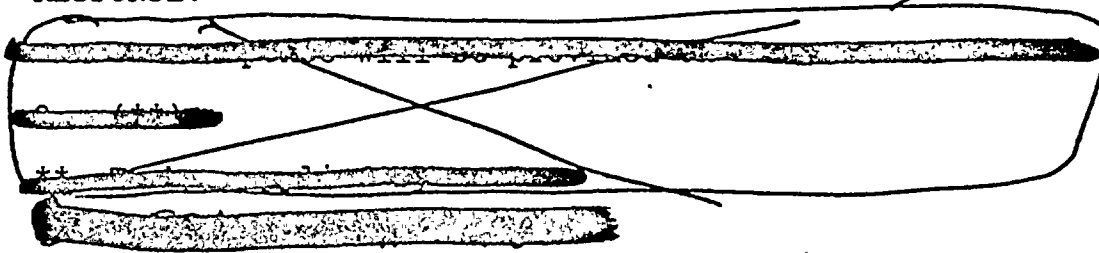

6

PVNGS will perform preoperational and startup tests to meet the requirements of Regulatory Guides 1.68 and 1.79 as outlined in CESSAR Chapter 14 for tests in CESSAR scope and PVNGS FSAR Chapter 14 for tests outside of CESSAR scope.



QUESTION 6A.48 (NRC Question 440.31) ✓

(6.3)

Provide a commitment that Palo Verde will perform tests of ECCS as installed to confirm that the actual ECCS flow rates are greater than the values assumed in the LOCA analyses.

RESPONSE: ~~_____~~

as described in CESSAR Chapter 14

PVNGS will perform tests of ECCS to confirm that the actual ECCS flow rates are greater than the values assumed in the LOCA analyses. during a preoperational test.



QUESTION 15A.4 (NRC Question 440.32) ✓ (15.0)

Expand Table 15.0-6, the list of single failure considered in transient and accident analyses, to include the following:

1. one primary safety valve stuck closed
2. one secondary safety valve fail to open or fail to close
3. loss of offsite power
4. failure of one diesel to operate (for the events with loss of offsite power being treated as a consequential result of the event).
5. failure to achieve fast transfer

RESPONSE: The response will be provided on the CESSAR docket.



QUESTION 15A.5 (NRC Question 440.33) ✓

(15.0)

For all analyses of transients with concurrent single failures, provide a reference to the sensitivity study which shows that the failure selected is the worst case single failure.

RESPONSE: The response will be provided on the CESSAR docket.

6



QUESTION 15A.6 (NRC Question 440.34) ✓

(15.0)

Confirm that during the preoperational or startup test phase you intend to verify the valve discharge rates and response times (such as opening and closing times for main feedwater, auxiliary feedwater, turbine and main steam isolation valves, and steam generator and pressurizer relief and safety valves) to show that they have been conservatively modeled in the Chapter 15.0 analyses.

RESPONSE:

~~_____~~
~~_____~~
~~_____~~

PVNGS intends to verify response times to show that they have been conservatively modeled in Chapter 15.0 analyses, during a preoperational test,

as described in CESSAR Chapter 14 for valves within the CESSAR scope and PVNGS FSAR Chapter 14 for valves outside the CESSAR scope.



QUESTION 15A.7 (NRC Question 440.35) ✓ (15.0)

The method that you have used for calculating the amount of failed fuel after an accident has not been approved. It is our position that fuel failures be recalculated using the criteria that any fuel rod which has a CE-1 DNBR less than the minimum DNBR value determined in Section 4.4 fails. Radiological consequences should be calculated accordingly.

RESPONSE: The response will be provided on the CESSAR docket.



QUESTION 15A.8 (NRC Question 440.36) ✓ (15.0)

Verify that for each transient analyzed in Chapter 15, if operator action is not discussed then no operator action is required. In particular, consider events in which the ECCS is actuated or RCP trip would be required based on present procedures.

RESPONSE: The response will be provided on the CESSAR docket.

6



QUESTION 15A.9 (NRC Question 440.37) ✓ (15.0)

For each accident, discuss non-safety grade equipment which was assumed to operate and could result in the transient becoming more severe or verify that no non-safety grade equipment operating would produce a more severe transient. For example, the pressurizer heaters being energized for a transient resulting in high RCS pressures could tend to worsen the effects of the transient. Likewise, pressurizer spray could be detrimental for a transient resulting in low RCS pressure.

RESPONSE: The response will be provided on the CESSAR docket,



QUESTION 15A.10 (NRC Question 440.38) ✓ (15.0)

Plant operators are instructed to trip the reactor coolant pumps (RCPs) during ECCS actuation. For a steam line break, tripping of the RCPs at varying times into the transient has not been addressed. Demonstrate, by analysis or otherwise, that the consequences of tripping the RCPs during a steam line break transient are bounded by the analyses already performed.

RESPONSE: The response will be provided on the CESSAR docket.

6



QUESTION 15A.11 (NRC Question 440.39) ✓ (15.0)

One of the key parameters in LOCA analyses is peak clad temperature. For non-LOCA transients, minimum DNBR (departure from nucleate boiling ratio) is of primary importance. For those transients analyzed in Section 15 of the FSAR, provide graphical output of the DNBR as a function of time.

RESPONSE: The response will be provided on the CESSAR docket.

6



QUESTION 15A.12 (NRC Question 440.40) ✓

(15.0)

As part of the CESEC review, the NRC intends to perform audit evaluations of feedwater line breaks, steam line breaks, and large- and small-break LOCAs (as part of the FSAR and TMI Action Plan Item II.K.3.30 and II.K.3.31 reviews). In order to perform these audits, we require the following data, as outlined in the "PWR Information Request Package."

RESPONSE: The response will be provided on the CESSAR docket.



QUESTION 15A.13 (NRC Question 440.41) ✓ (15.0)

The current CESEC model does not properly account for steam formation in the reactor vessel. Therefore, for all events in which (a) the pressurizer is calculated to drain into the hot leg, or (b) the system pressure drops to the saturation pressure of the hottest fluid in the system during normal operation, we require the applicant to reanalyze these events with an acceptable model or otherwise justify the acceptability of Palo Verde Chapter 15 analyses conclusions performed with CESEC.

RESPONSE: The response will be provided on the CESSAR docket.

6



QUESTION 15A.14 (NRC Question 440.42) ✓ (15B)

Figure 15B-19 shows the primary system pressure exceeding 110% of the design pressure. This figure also indicates a substantial pressure differential between the pressurizer and reactor vessel. The standard review plans typically limit the pressurization of the RCS to 110% of the design pressure. However, the ASME pressure vessel code permits exceeding the 110% limit to approximately 120% for very low probability events. The NRC will accept the limiting pressurization transient (i.e., feedwater line break) as calculated for System 80 if we can be assured that the analysis performed is conservative and that a small break in the feedwater line is a very low probability event.

As such, we request the following information be provided:

- (1) Verification of CESEC to predict pressurization transients. This should include the developed pressure differential across the pressurizer surge line.
- (2) Demonstrate that the probability of a small break in the feedwater system is not significantly more probable than the large break. Include the consideration of ancillary line breaks.
- (3) Section 15B.3 references a sensitivity study for RCS overpressurization transient to plant initial conditions. Provide the results to this study in graphical form. Specifically, include DNBR and pressure as a function of time.
- (4) It is expected that increasing the break area for a feedwater line break would increase the degree of primary system pressurization. A larger break area should result in an earlier loss of heat sink and corresponding higher decay heat for system pressurization. Figure 15B-1 indicates that the limiting feedwater line break is not a double-ended



APPENDIX 15A

guillotine break (1.4 ft²), but a 0.2 ft² break. Provide greater details as to why this occurs. Is this behavior considered realistic or a consequence of a modeling assumption? Provide additional graphical explanations, including heat transfer coefficient, heat flow, secondary side inventory, all secondary side flow rates, and any additional data required to demonstrate the reasons for the 0.2 ft² break being the limiting break size.

- (5) Figure 15B-10 provides the relationship between the maximum RCS pressure to initial steam generator inventory. Provide additional information which explains in detail functional behavior of this curve. Provide the RCS pressure curves for the cases of initial SG inventory of 95,000 and 170,000 lbm. Describe the SG heat transfer occurring throughout these events.

6 Page 15B-5 states: "...the initial RCS pressure can be adjusted to provide simultaneous reactor trip signals from high pressurizer pressure, and low water level in the intact steam generator and hence the plateau of maximum RCS pressure." Provide greater details of the analyses and assumptions made in order to achieve coincident trip signals from the pressurizer and SG.

- (6) For Figure 15B-11 (and page 15B-6), how does raising the degree of feedwater subcooling increase the maximum RCS pressure? It would appear that raising the degree of subcooling would result in a larger heat sink, and, therefore, a lower peak pressure.
- (7) What decay heat model does CESEC use? Does this model assume infinite irradiation?
- (8) Provide details of the core and steam generator heat transfer models used in CESEC.



- (9) Utilizing a one-node representation of the steam generator secondary side, how is the low liquid level trip analyzed?
- (10) Provide verification of the CESEC pressurizer model for pressurization transients (resulting in the opening of a safety valve or PORV) with data from experiments and operating plant transients. Of interest is level and pressure as a function of time. Document the assumptions made in analyzing these tests.
- (11) Document the sensitivity of a feedwater line break with and without loss of offsite power.

RESPONSE: The response will be provided on the CESSAR docket.



QUESTION 15A.15 (NRC Question 440.43) ✓

(15B)

For the feedwater line break analysis, provide the pressurizer liquid and mixture level as a function of time.

Provide detailed plots for the following parameters during the initial 50 seconds of the transient:

1. Pressurizer Pressure
2. Surge line flow
3. Pressurizer mixture level
4. Pressurizer Safety Valve flow and quality

RESPONSE: The response will be provided on the CESSAR docket.

6



QUESTION 15A.16 (NRC Question 440.44) ✓ (15.0)

We require additional information regarding the steam generator behavior during a feedwater line break. Provide the steam generator secondary side coolant inventory, mixture level, heat transfer coefficients, energy removed by each steam generator (Btu) and secondary side flow as a function of time.

It is our understanding that the limiting heat transfer modeling technique utilized in CESEC assumes an approximately constant heat transfer coefficient between the primary and secondary systems until all the liquid mass in the secondary system is depleted (i.e., $\Delta M = 0$). It is not clear why the limiting modeling technique was not the case where the heat transfer was degraded as the secondary side inventory began uncovering the tubes. Please explain.

Discuss differences in the steam generator secondary heat transfer modeling between a feedwater line break and a steam line break.

RESPONSE: The response will be provided on the CESSAR docket.



QUESTION 15A.17 (NRC Question 440.45) ✓ (15.1.3)

The stuck-open atmospheric dump valve analysis assumed operator action to scram the core 1200 seconds into the transient. Justify the time of manual action. Provide details of the plant symptoms which will alert the operator of the stuck-open dump valve. When will the plant automatically scram without operator intervention? Discuss the failures assumed in the analysis.

Question 440.41 addresses concerns with the capability of the CESEC code to properly account for primary system voiding. Address the concerns of this position as they related to your analysis of the stuck-open atmospheric dump valve event.

Provide graphical output of the mass flow rate exiting the dump valve as a function of time.

When analyzing a stuck-open dump valve, operator action was required to isolate the feedwater from the affected steam generator. Justify the conservatism of time for operator action assumed in the analysis. What signals do the operators receive signifying that the feedwater should be isolated? When assuming tech-specs limits for the steam generator tube leakage, describe how CESEC accounts for the primary to secondary mass depletion. In the analysis, the primary system was initialized to design operating conditions. Address the conservatism of this assumption when compared to off-nominal tech-specs limits and hot standby conditions.

RESPONSE: The response will be provided on the CESSAR docket.



QUESTION 15A.18 (NRC Question 440.46) ✓ (15.0)

Accidents resulting in containment isolation also isolate the component cooling water to the reactor coolant pumps. This can potentially lead to RCP seal damage which may result in a LOCA. Address the time available for the operators to restore the coolant to the seals. Has consideration been given to not isolating component cooling water to the RCP seals on containment isolation? If pump seal integrity cannot be maintained, evaluate the consequential failure of the pump seals for the limiting accident.

RESPONSE: The response will be provided on the CESSAR docket.



QUESTION 15A.19 (NRC Question 440.47) ✓

(15.1.4)

Section 15.1.4.2 addresses small steam line breaks outside containment (SSLBOC). The following questions relate to this section:

- (1) Justify why a SSLBOC is limited to 11.5% of full power turbine flow.
- (2) Update Table 15.1.4.2-1 to include Safety Injection Tank (SIT) initiation time. Also, provide SIT and HPI flow as function of time.
- (3) During a small steam line break, the reactor core initially responds to a load demand. What break size results in the highest power excursion? For the limiting break size, provide graphical output of the system pressure, core power, and DNBR as a function of time.
- (4) Explain why the liquid mass within the broken steam generator increases after 1080 seconds. Isn't the steam generator isolated? If not, why not?
- (5) Why was the open dump valve accident (Section 15.1.3) analyzed at full power and the small steam line break (Section 15.1.4) analyzed at zero power? Assuming a tech-spec steam generator tube leakage of 1 gpm for both analyses, why wasn't the resulting dosage the same?
- (6) What was the single failure assumed for the small steam line break? Justify the single failure selection as resulting in the limiting conditions.
- (7) Provide graphical output of the ECC flows as a function of time and indicate when boron began to penetrate the primary system. How is the time to boron injection derived?
- (8) Address the consequence of loss of AC power during the transients analyzed.



APPENDIX 15A

- (9) Question 440.41 addresses concerns with the capability of the CESEC code to properly account for primary system voiding. Address the concerns of this question as they relate to your analysis of small steam line break outside of containment.
- (10) Provide diagrams of the reheater offlines (include dimensions, loss coefficients, interconnections between the steam lines). This data should be sufficiently detailed to enable the NRC to conduct an audit of a steam line break coincident with a failure of an MSIV to close. Provide results for this accident (i.e., system pressure, pressurizer level, DNBR ratios, ECCS flows, steam generator flows, etc.) assuming with and without loss-of-offsite power. Address the consequence of losing offsite power during the steam line break.
- (11) Analysis of an inadvertent opening of a turbine bypass valve has not been provided. For this accident, will the DNBR fall below 1.19 as it did for Waterford? If not, discuss the differences between the plants which cause the DNBR limit to be exceeded for one plant and not the other. If the DNBR limit is exceeded, provide a detailed analysis for this event.

Provide a list of all accidents (excluding primary system LOCAs) which result in a DNBR less than 1.19.

- (12) Compare the steam flow model utilized in CESEC with the Moody slip flow model.

RESPONSE: The response will be provided on the CESSAR docket.



QUESTION 15A.20 (NRC Question 440.48) ✓

(15.0)

Provide a list of transients which result in opening of the
pressurizer safety valves.

RESPONSE: The response will be provided on the CESSAR
docket.

6



QUESTION 15A.21 (NRC Question 440.49) ✓ (15.0)

The staff has been informed that the CESEC-III computer program is best suited to analyze transients which void the upper head of the reactor vessel. As such, we request that the following information be provided:

- (1) Documentation of the CESEC-III code. As part of the documentation, address the differences between the different versions of CESEC (I, II, and III).
- (2) Provide comparative analyses with the different versions of the CESEC programs (used for licensing) to demonstrate the adequacy of previous analyses.
- (3) Provide verification of CESEC-III against plant and experimental data for pressurization and depressurization transients (such as the ANO-2 experiments and the St. Lucie I cooldown experience).
- (4) For those transients which result in primary system voiding, provide graphical output of the upper head mixture level as a function of time. Discuss operator actions/guidelines for detecting and mitigating primary system void formation.
- (5) Show, by analysis or otherwise, that the allowable cooling rate (for cold shutdown conditions) will not result in primary system voiding.

RESPONSE: The response will be provided on the CESSAR docket.



QUESTION 15A.22 (NRC Question 440.50) ✓ .

(15.0)

Do all CE steam generator designs incorporate a flow restrictor in the steam generator outlet nozzles?

RESPONSE: The response will be provided on the CESSAR docket.

6



QUESTION 15A.23 (NRC Question 440.51) ✓ (15.0)

Section 15C.3.1.3.3 is confusing. Provide greater detail of the reactor vessel mixing model. How do the various versions of CESEC evaluate asymmetric temperatures between the loops during a FWLB and a SLB (assuming with and without loss of offsite power)? Provide experimental verification for these models.

RESPONSE: The response will be provided on the CESSAR docket.

6



QUESTION 15A.24 (NRC Question 440.52) ✓

(15.0)

Section 15C.3.3 implies that during a SLB, concurrent with loss-of-offsite power, the reactor trips on a low DNBR signal. It is our understanding that CESEC does not calculate DNBR. How is the time of reactor trip calculated?

RESPONSE: The response will be provided on the CESSAR docket.

6



QUESTION 15A.25 (NRC Question 440.53) ✓ (15.0)

The inadvertent opening of an atmospheric dump valve event is considered as a moderate frequent event per SRP 15.1.1. Confirm that the analysis performed for this event in Section 15.1.3.2 is the limiting case identified by a qualitative comparison from the events in the same category group specified in SRP 15.1.1 (e.g., decrease in feedwater temperature, increase in feedwater flow, increase in steam flow, and inadvertent opening of a steam generator relief or safety valve). The qualitative analyses for each of the events in this group should be presented in the FSAR for staff review. Also, the results of analyses should be presented in the FSAR for each event with their worst single failure combination and the limiting case is identified.

RESPONSE: The response will be provided on the CESSAR docket.



QUESTION 15A.26 (NRC Question 440.54) ✓ (15.0)

The depressurization transients analyzed for System 80 were conducted utilizing the CESEC-II computer program. This program does not account for steam formation in the upper head of the reactor vessel nor for steam formation in the primary system after the pressurizer empties. Neglecting these effects can result in the improper evaluation of the system pressure and hydraulic behavior. The importance of this phenomenon was demonstrated by the St. Lucie I natural circulation cooldown event of June 11, 1980.

The modeling deficiency in CESEC-II described above has the potential for providing unacceptable results for the depressurizing transients analyzed in the FSAR. As such, for all transients which empty the pressurizer or may result in saturated conditions elsewhere in the primary system, the CESEC-II computer program must be verified to demonstrate it can correctly calculate system thermal-hydraulic responses. The staff requires the applicant to demonstrate the acceptability of the CESEC-II program to properly account for the thermal-hydraulic phenomena in question, and to demonstrate compliance with NRC regulations. In addition, we require a description of the SESEC code's ability to calculate the asymmetric cooldown between the intact and broken loops. Overlay plots of the hot leg and cold leg temperatures in the intact and broken loops should be provided.

RESPONSE: The response will be provided on the CESSAR docket.



QUESTION 15A.27 (NRC Question 440.55) ✓ (15.6)

For small-break LOCAs, containment isolation may occur. It is our understanding that component cooling water to the RCP seals will be isolated upon containment isolation. Demonstrate that the RCP seals will remain intact and maintain the pressure boundary for the duration of the accident. Address expected RCP operation. If seal integrity cannot be maintained, seal failure must be assumed. Discuss the maximum seal leakage rates based on operating experience. If the consequences of seal failure are assumed to be covered by the analyzed break spectrum, justify the differences in the break locations from the locations analyzed.

RESPONSE: The response will be provided on the CESSAR docket.



QUESTION 6A.49 (NRC Question 440.56) ✓

(6.3)

The LOCA break spectrum analyses presented are stipulated to be applicable to any System 80 plant that conforms to the interface requirements specified within Section 6.3.3. The submittal for the LOCA analyses does not address the effects of steam generator tube plugging. The effect of a decrease in steam generator tube flow area is an increase in the peak cladding temperature (when the peak occurs during the reflood portion of the transient). If the analyses provided are considered to support generators with plugged tubes, describe the intent of the plugging the analyses support and the method used to account for the plugging. If steam generator tube plugging was not considered, the applicant will be required to perform additional ECCS analyses prior to operation with plugged generator tubes. In either case, the applicant is required to include an interface requirement on the validity of the LOCA analysis (acceptance criteria of 10 CFR 50.46) and the Technical Specification limit for the number (or percentage) of allowable plugged steam generator tubes.

RESPONSE: The response will be provided on the CESSAR docket.



QUESTION 15A.28 (NRC Question 440.57) ✓ (15.6)

In light of recent operating experiences (the St. Lucie Unit 1 natural circulation cooldown event of June 11, 1980, and re-analyses of SAR Chapter 15 design bases events by St. Lucie in February 1981) a potential deficiency has been identified with the CESEC computer program and NSSS model. As the pressurizer cools down and the system pressure decreases, steam can form in the reactor vessel upper head due to flashing of the hot coolant in this stagnant region. The steam bubble in the reactor vessel upper head displaces coolant from the reactor vessel into the pressurizer and the steam in the vessel head will determine the system pressure. The CESEC model used for the steam generator tube rupture event does not account for this occurrence. Further, CESEC analyses which predict that the pressurizer will empty, or that the reactor coolant system saturates, do not appear to correctly calculate the system thermal-hydraulic response and are not justified for use. These events are to be re-analyzed with a suitable model or additional justification is to be provided for the CESEC analyses to demonstrate that the computer program conservatively accounts for the formation of steam in the reactor coolant system.

RESPONSE: The response will be provided on the CESSAR docket.



QUESTION 15A.29 (NRC Question 440.58) ✓ (15.6.2)

The analysis for a steam generator tube rupture does not address tube leakage in the unaffected steam generator. Provide an interface requirement for the allowable steam generator tube leakage and reference the Technical Specification limit. Confirm the analyses were performed using this allowable limit or provide justification why this leakage term can be excluded from the analyses.

RESPONSE: The response will be provided on the CESSAR docket.

6



QUESTION 15A.30 (NRC Question 440.59) ✓ (15.6.2)

The analysis for a steam generator tube rupture is for a double-ended rupture. Provide the analyses used to determine that this is the limiting case. If a partial area break is considered, such that the steam generator relief valves open at a longer time into the transient is more primary coolant leaked to the secondary and out the SRVs, resulting in an increased dose rate.

RESPONSE: The response will be provided on the CESSAR docket.

6



QUESTION 15A.31 (NRC Question 440.60) ✓ (15.6.2)

SRP 15.6.3 acceptance criteria requires that this event be analyzed with a concurrent loss of offsite power. Provide an analysis for the limiting case which includes a concurrent loss of offsite power.

RESPONSE: The response will be provided on the CESSAR docket.

6



QUESTION 15A.32 (NRC Question 440.61) ✓ (15.6.2)

For the SGTR event, what prevents steam from the affected steam generator being used to drive the steam-driven auxiliary feed-water pump and exhausted to the environment? If operator action is required, confirm that no credit for operator action was given for 30 minutes, consider with your assumption for isolation of the affected steam generator. If credit was given for operator action in less than 30 minutes, provide justification why this credit can be given, or reanalyze the event assuming steam from the faulted steam generator is used to drive the steam-driven AFW pump and is exhausted to the environment.

RESPONSE: The response will be provided on the CESSAR docket.



QUESTION 15A.33 (NRC Question 440.62) ✓

(15.6.3,4,5)

Provide a description of the CESEC model used to model the CVCS from the reactor coolant system to the break point. Include a description of the environmental conditions at the break point (pressure, enthalpy, break flow model used).

RESPONSE: The response will be provided on the CESSAR docket.

6



QUESTION 15A.34 (NRC Question 440.63) ✓

(15.6.3,4,5)

Discuss the single failure assumed for these analyses. What analyses/evaluations were performed to justify that the single failures chosen were the most limiting?

RESPONSE: The response will be provided on the CESSAR docket.

6



QUESTION 15A.35 (NRC Question 440.64) ✓ (15.0)

In this section, you have selected the turbine trip without a single failure as the limiting reactor coolant system pressure and the limiting radiological release event for the moderate frequent event category in the decreased heat removal by secondary system group. However, these limiting cases were not selected by a qualitative comparison of similar initiating events specified in SRP 15.2.1 through SRP 15.2.7 (e.g., loss of external load, turbine trip, loss of condenser vacuum, steam pressure regulator failure, loss of normal AC power and loss of normal feedwater flow). Provide a qualitative analysis in the FSAR for each of the initiating events in the same group per the SRP, and identify the limiting cases for the group. Provide a detail quantitative analysis for each of the limiting cases including the limiting RCS pressure, limiting fuel performance, and the limiting radiological release.

RESPONSE: The response will be provided on the CESSAR docket.



QUESTION 15A.36 (NRC Question 440.65) ✓ (15.2)

In this section, you have provided the loss of condenser vacuum with a fast transfer failure and technical specification steam generator tube leakage as the limiting RCS pressure and the limiting radiological release event for the limiting fault event category in the decreased heat removal by secondary system group. Although, these limiting cases may be the candidates for the limiting cases for the infrequent event category in the group, they were not selected by a qualitative comparison of similar initiating events plus a single failure specified in SRP 15.2.1 through 15.2.7. Provide a qualitative analysis in the FSAR for each of the initiating event plus a single failure in the same group per the SRP, and identify the limiting cases for the group. Provide a detailed quantitative analysis for each of the limiting cases including the limiting RCS pressure, limiting fuel performance, and the limiting radiological release. Confirm that the results of the analyses meet the acceptance criteria for these events per SRP 15.2.1.

RESPONSE: The response will be provided on the CESSAR docket.



QUESTION 15A.37 (NRC Question 440.66) ✓ (15A)

Provide tabulations of the sequence of events, disposition of normally operating systems, utilization of safety systems, and a transient curve of primary system pressure for the total loss of primary coolant flow event. Also provide an analysis of the total loss of primary coolant flow with a single failure event. Confirm that the results of these analyses meet the acceptance criteria for these events per SRP 15.3.1.

RESPONSE: The response will be provided on the CESSAR docket.



QUESTION 15A.38 (NRC Question 440.67) ✓ (15.3)

In Section 15.3.5 you have provided the single reactor coolant pump shaft seizure with loss of offsite power following turbine trip and with technical specification tube leakage as the limiting RCS pressure and radiological release event for the limited fault event category. This postulated event is classified as an infrequent event per SRP 15.3.3. Confirm that the results of the analysis meet the acceptance criteria for these events per SRP 15.3.3, using the criteria stated in Question 440.35 to calculate the amount of failed fuel in this event. State the amount of failed fuel in the results of the analysis. Radiological consequences should be calculated accordingly.

RESPONSE: The response will be provided on the CESSAR docket.



QUESTION 15A.39 (NRC Question 440.68) ✓

(15.0)

Provide results of an analysis of the reactor coolant pump shaft break as required by SRP 15.3.4 for staff review. The event should consider loss of offsite power following turbine trip and with technical specification steam generator tube leakage. The criteria stated in Question 440.35 should be used for the calculation of the amount of failed fuel for this event. State the amount of failed fuel in the results of the analysis. Radiological consequences should be calculated accordingly. Confirm that the results of the analysis meet the acceptance criteria for these events per SRP 15.3.4 which classifies this event as an infrequent event.

RESPONSE: The response will be provided on the CESSAR docket.



QUESTION 15A.40 (NRC Question 440.69) ✓

(15.5)

In this section, you have provided the pressurizer level control system malfunction (PLCSM) with a fast transfer failure and the PLCSM with a loss of offsite power at turbine trip with technical specification steam generator tube leakage as the limiting RCS pressure and radiological release event for the limiting fault event category in the increase in reactor coolant system inventory group. However these limiting cases were not selected by a qualitative comparison of similar initiating events plus a single failure specified in SRP 15.5.1 (e.g., inadvertent operation of high pressure ECCS or a malfunction of the CVCS). Provide a qualitative analysis in the FSAR for each of the initiating events (with and without a single active failure) in the same group per the SRP, and identify the limiting cases for the group. Provide a detailed quantitative analysis for each of the limiting cases including the limiting RCS pressure, limiting fuel performance, and the limiting radiological release. Confirm that the results of the analyses meet the acceptance criteria for these events per SRP 15.5.1.

RESPONSE: The response will be provided on the CESSAR docket.



QUESTION 15A.41 (NRC Question 440.70) ✓ (15.0)

Provide tabulations of the sequence of events, disposition of normally operating systems, utilization of safety systems, and all necessary transient curves for the startup of an inactive reactor coolant pump event. The comparison to peak RCS pressure acceptance criteria should be included in the analysis. Also provide the results of an analysis of this event with a single failure. Confirm that the results of these analyses meet the acceptance criteria for these events per SRP 15.4.4.

RESPONSE: The response will be provided on the CESSAR docket.

6



QUESTION 15A.42 (NRC Question 440.71) ✓ (15.D)

You have provided, in Section 15D, the results of an inadvertent boron dilution event without a single failure under plant cold shutdown conditions. This information is not sufficient. You should provide results of analyses for all possible boron dilution events under various plant operational modes (e.g., refueling, startup, power operation, hot standby and cold shutdown). Also provide the results of analyses of these events with a single failure. Confirm that the results of these analyses meet the acceptance criteria for these events per SRP 15.5.1. In particular, the available times per operator action between time of alarm and time to loss of shutdown margin should be shown to meet the SRP guidelines. The results of the analyses should be presented in the FSAR including tabulations of sequence of events, disposition of normally operating systems, utilization of safety systems, and all necessary transient curves for the events. 6

In your analysis, indicate for all modes of operation what alarms would identify to the operators that a boron dilution event was occurring. Consider the failure of the first alarm. Provide the time interval from this alarm to when the core would go critical. If a second alarm is not provided, show that the consequences of the most limiting unmitigated boron dilution event meet the staff criteria and are acceptable.

RESPONSE: The response will be provided on the CESSAR docket.



QUESTION 15A.43 (NRC Question 440.72) ✓ (15.2)

As explained in Issue No. 1, NUREG-0138, credit is taken for closure of nonsafety-grade valves such as turbine stop valves, control valves, and bypass valves downstream of the MSIV to limit blowdown of a second steam generator in the event of a steam line break upstream of the MSIV. In the Palo Verde Plant design there are various flow paths located between the MSIV and the turbine stop valves (Figure 10.2-4) that serve various unidentified functions. To confirm satisfactory performance after a steam line break provide the following information, as applicable, related to these various flow paths that branch off between the MSIV's and the turbine stop valves:

- (1) the function of the various flow paths and their maximum steam flow
- (2) the type of valves
- (3) the size of valves
- (4) the quality of the valves
- (5) design code of the valves
- (6) the closure time of the valves
- (7) the actuation mechanism of the valves
- (8) the closure signal including sensor
- (9) quality of power sources to valves and sensors
- (10) quality of air supply to air-operated valves
- (11) identify the valves that will remain open during main steam isolation

In addition, provide justification or analysis that the failure of an MSIV and the additional blowdown paths result in a less severe accident than that analyzed in Chapter 15.

RESPONSE: ^{Additional information} ~~The response~~ is contained in the amended ^{response} ~~reply~~ to question 10A.9 (NRC Question 430.45).

SPVNGS meets the interface requirement identified in the CESSAR response.



APPENDIX 10A

QUESTION 10A.9 (NRC QUESTION 430.45)

(10.3)

As explained in issue No. 1 of NUREG 0138, credit is taken for all valves downstream of the Main Steam Isolation Valve (MSIV) to limit blowdown of a second steam generator in the event of a steam line break upstream of the MSIV. In order to confirm satisfactory performance following such a steam line break provide a tabulation and descriptive text (as appropriate) in the FSAR of all flow paths that branch off the main steam lines between the MSIV's and the turbine stop valves. For each flow path originating at the main steam lines, provide the following information:

- a) System identification
- b) Maximum steam flow in pounds per hour
- c) Type of shut-off valve(s)
- d) Size of valve(s)
- e) Quality of the valve(s)
- f) Design code of the valve(s)
- g) Closure time of the valve(s)
- h) Actuation mechanism of the valve(s) (i.e., Solenoid operated, motor operated, air operated diaphragm valve, etc.)
- i) Motive or power source for the valve actuating mechanism

In the event of the postulated accident, termination of steam flow from all systems identified above, except those that can be used for mitigation of the accident, is required to bring the reactor to a safe cold shutdown. For these systems describe what design features have been incorporated to assure closure of the steam shut-off valve(s). Describe what operator actions (if any) are required.

If the systems that can be used for mitigation of the accident are not available or decision is made to use other means to



APPENDIX 10A

shut down the reactor describe how these systems are secured to assure positive steam shut-off. Describe what operator actions (if any) are required.

If any of the requested information is presently included in the FSAR text, provide only the references where the information may be found.

RESPONSE: NUREG-0138 page 1-9 states that the probability of occurrence of the above scenario is quite low. Page 1-10 states that the scenario is not analyzed by the staff and need not be considered as a design basis accident. This scenario should therefore not be a design basis accident for Palo Verde Units 1, 2 & 3.

Refer to the following P&ID's:

- 13-M-SGP-001 (figure 10.3-1)
- 13-M-SGP-002 (figure 10.3-1)
- 13-M-FTP-001 (figure 10.3-3)
- 13-M-CDP-001 (figure 10.4-9)
- 13-M-MTP-001 (figure 10.2-1)
- 13-M-MTP-002 (figure 10.2-1)
- 13-M-ASP-001 (figure 10.3-2)
- 13-M-GSP-001 (figure 10.4-2)

Table 10A-1 lists the information requested. The table shows valve positions following MSIS isolation. For those valves which remain open, the total steam flow through these valves is 253,955 lb/h. Each auxiliary feedwater pump (AFW) has a capacity of 484,000 lb/h. Therefore, even for the extreme situation postulated, any auxiliary feedwater pump can prevent the second steam generator from boiling dry.

QUESTION 10A.10 (NRC QUESTION 430.46)

(10.4.1)

Provide a tabulation in your FSAR showing the physical characteristics and performance requirements of the main condensers. In



Table 10A-1

FLOW PATHS ORIGINATING AT MAIN STEAM LINES (Sheet 1 of 2)

System Identification	Max. Steam Flow (LB/HR)	Type of Shut-off Valves	Size of Valve	Quality of Valve	Design Code of Valve	Closure Time of Valve (Seconds)	Actuation Mechanism	Motive or Power Source	Closure Signal (Sensor)	Quality of Power Source	Quality of Air Supply	Position Status of Valve After MSIV Isolation	Comment
SG-V093 (or AS-V004)	1925	Gate (Gate)	6"	Non-Q	ANSI B31.1	15	Manual	N/A	N/A	N/A	N/A	Open	Aux steam supply (13-M-ASP-001) (13-M-SCP-002)
SG-V094 (or AS-V012)	1925	Gate (Gate)	6"	Non-Q	ANSI B31.1	15	Manual	N/A	N/A	N/A	N/A	Open	
SG-V095 (or AS-V013)	105	Globe (Gate)	3"	Non-Q	ANSI B31.1	10	Manual	N/A	N/A	N/A	N/A	Open	
HT-UV-1004 (or UV-1005)	4.25x10 ⁶	Globe	28"	Non-Q	ANSI B31.1	0.2	Hydraulic	Trip of turbine speed control system (actuated on MSIS parameters)	MSIS Actuation Signal (Low S/G Pressure)	Non-IE	N/A	Closed	Main steam supply to main turbine (13-M-MTP-001)
HT-UV-1006 (or UV-1007)	4.25x10 ⁶	Globe	28"	Non-Q	ANSI B31.1	0.2	Hydraulic	Trip of turbine speed control system (actuated on MSIS parameters)	MSIS Actuation Signal (Low S/G Pressure)	Non-IE	N/A	Closed	
HT-UV-1002 (or UV-1001)	4.25x10 ⁶	Globe	28"	Non-Q	ANSI B31.1	0.2	Hydraulic	Trip of turbine speed control system (actuated on MSIS parameters)	MSIS Actuation Signal (Low S/G Pressure)	Non-IE	N/A	Closed	
HT-UV-1000 (or UV-1003)	4.25x10 ⁶	Globe	28"	Non-Q	ANSI B31.1	0.2	Hydraulic	Trip to turbine speed control system (actuated on MSIS parameters)	MSIS Actuation Signal (Low S/G Pressure)	Non-IE	N/A	Closed	
SG-UV-035	50,000	Globe	2"	Non-Q	ANSI B31.1	10	Motor		N/A	Non-IE	N/A	Open	Bleed off line between MSIV's and turbine stop valves (opens on turbine trip) (13-M-SCP-002)
SG-UV-036	50,000	Globe	2"	Non-Q	ANSI B31.1	10	Motor	Non-IE, 480V, 3 phase, 60 cycle	N/A	Non-IE	N/A	Open	
SG-UV-037	50,000	Globe	2"	Non-Q	ANSI B31.1	10	Motor		N/A	Non-IE	N/A	Open	
SG-UV-038	50,000	Globe	2"	Non-Q	ANSI B31.1	10	Motor		N/A	Non-IE	N/A	Open	

PVNGS FSAR

APPENDIX 10A

440,72

41
Amendment 5
10A-8
August 1981



Table 10A-1

FLOW PATHS ORIGINATING AT MAIN STEAM LINES (Sheet 2 of 2)

System Identification	Max. Steam Flow (LB/HR)	Type of Shut-off Valves	Size of Valve	Quality of Valve	Design Code of Valve	Closure Time of Valve (Seconds)	Actuation Mechanism	Motive or Power Source	Closure Signal (Sensor)	Quality of Power Source	Quality of Air Supply	Position Status of Valve After MSIV Isolation	Comment			
SG-PV-1007	1,240,000	Globe	12"	Non-Q	ANSI B31.1	15	Pneumatic	Instrument Air	Solenoid permissive to open (Non-IE 120V dc) SGRD permissive signal logic (Non-IE 120V ac)	Non-IE	ANSI B31.1	Closed	Main steam blow-down at atmos. vent restrictor (1J-M-SGP-002)			
SG-PV-1008	1,240,000	Globe	12"	Non-Q	ANSI B31.1	15	Pneumatic			Non-IE	ANSI B31.1	Closed				
SG-PV-1002	1,240,000	Globe	12"	Non-Q	ANSI B31.1	15	Pneumatic			Non-IE	ANSI B31.1	Closed				
SG-PV-1001	1,240,000	Globe	12"	Non-Q	ANSI B31.1	15	Pneumatic			Non-IE	ANSI B31.1	Closed				
SG-PV-1003	1,240,000	Globe	12"	Non-Q	ANSI B31.1	15	Pneumatic			Non-IE	ANSI B31.1	Closed				
SG-PV-1004	1,240,000	Globe	12"	Non-Q	ANSI B31.1	15	Pneumatic			Non-IE	ANSI B31.1	Closed				
SG-PV-1005	1,240,000	Globe	12"	Non-Q	ANSI B31.1	15	Pneumatic			Non-IE	ANSI B31.1	Closed				
SG-PV-1006	1,240,000	Globe	12"	Non-Q	ANSI B31.1	15	Pneumatic			Non-IE	ANSI B31.1	Closed				
FT-NV-65 (or NV-67)	120,000	Globe	5"	Non-Q	ANSI B31.1	0.3	Hydraulic	MFW Pump Turbine Speed Control System	MFW pump trip ^(a) logic (MSIS)	Non-IE	N/A	Closed	Main steam supply to MFW pump turbine			
FT-NV-66 (or NV-68)	120,000	Globe	5"	Non-Q	ANSI B31.1	0.3	Hydraulic			Non-IE	N/A	Closed				
HT-UV-328B	262,500	Globe	10"	Non-Q	ANSI B31.1	75	Motor			Electrical (Non-IE, 480V, 3 phase 60 cycle)	Load sensing logic on main turbine, (i.e., pressure switch PSL 512)	Non-IE		N/A	Closed	Main steam supply to moisture separator reheater
HT-UV-328A	262,500	Globe	10"	Non-Q	ANSI B31.1	75	Motor					Non-IE		N/A	Closed	
HT-UV-328D	262,500	Globe	10"	Non-Q	ANSI B31.1	75	Motor	Non-IE	N/A			Closed				
HT-UV-328C	262,500	Globe	10"	Non-Q	ANSI B31.1	75	Motor	Non-IE	N/A			Closed				
GS-NV-005	50,000	Gate	4"	Non-Q	ANSI B31.1	10	Motor	Electric (Non-IE, 480V, 3 phase, 60 cycle)	Control room handswitch	Non-IE	N/A	Open (closed by plant operator)	Main steam supply to gland seal			

a. MFW pump turbine trips on high discharge pressure due to MFW isolation valves going shut on main steam isolation signal (MSIS) (low steam generator pressure).

August 1981

08-12-81

10A-9

Amendment 5

14



PVNGS FSAR

APPENDIX 15A

QUESTION 15A.44 (NRC Question 440.73) ✓ (15.D)

Several recent LERs indicate there has been a deficiency in the inadvertent boron dilution analysis at some plants. Provide an analysis of the dilution event when the RCS is drained to the hot leg.

RESPONSE: The response will be provided on the CESSAR docket.

6



PVNGS FSAR

APPENDIX 15A

QUESTION 15A.45 (NRC Question 440.74) ✓ (15.D)

Recently, an operating PWR experienced a boron dilution incident due to inadvertent injection of NaOH into the reactor coolant system while the reactor was in a cold shutdown condition. Discuss the potential for a boron dilution incident caused by dilution sources other than the CVCS.

RESPONSE: The response will be provided on the CESSAR docket.

6



QUESTION 15A.45 (NRC Question 440.74) ✓ (15.D)

Recently, an operating PWR experienced a boron dilution incident due to inadvertent injection of NaOH into the reactor coolant system while the reactor was in a cold shutdown condition. Discuss the potential for a boron dilution incident caused by dilution sources other than the CVCS.

RESPONSE: The response will be provided on the CESSAR docket.



QUESTION 15A.46 (NRC Question 440.75) ✓

(15.6)

Discuss the transient resulting from a break of an ECCS injection line. In particular, describe the flow splitting which will occur in the event of a single failure and verify that the amount of flow actually reaching the core is consistent with the assumptions used in the analysis.

RESPONSE: The response will be provided on the CESSAR docket.

6



QUESTION 15A.47 (NRC Question 440.76) ✓

(15.8)

The NRC is currently considering what actions may be necessary to reduce the probability and consequences of anticipated transients without Scram (ATWS). Until such time as the Commission determines what plant modifications are necessary, we have generally concluded that pressurized water plants can continue to operate because the risk from anticipated transient without scram events in a limited time period is acceptably small. However, in order to further reduce the risk from anticipated transient without scram events during the interim period before completing the plant modifications determined by the Commission to be necessary, we have required that the following actions be taken:

1. Develop emergency procedures to train operators to recognize anticipated transient without scram events, including consideration of scram indicators, rod position indicators, flux monitors, pressurizer level and pressure indicators, prssurizer relief valve and safety valve indicators, and any other alarms annunciated in the control room with emphasis on alarms not processed through the electrical portion of the reactor scram system.
2. Train operators to take actions in the event of an anticipated transient without scram, including consideration of manually scrambling the reactor by using the manual scram button, prompt actuation of the auxiliary feedwater system to assure delivery to the full capacity of this system, and initiation of turbine trip. The operator should also be trained to initiate boration by actuation of the high pressure safety injection system to bring the facility to a safe shutdown condition.

Describe how you will meet the above requirements, and provide a schedule for submittal of the ATWS procedures for staff review.

RESPONSE: ~~_____~~

INSERT A → ~~_____~~



INSERT A to page 15A.47-1

440.76

Procedures will be developed to cover emergencies and off-normal events. These procedures will provide sufficient guidance to ensure that correct action is taken by the operator. ATWS events will be covered in these procedures. PVNGS will provide training on ATWS events and emergency and off-normal procedures. Sufficient information will be provided so that the operator can determine if his actions are effective. Should the operator's actions not be effective, the procedure will contain additional action that can be taken by the operator to ensure the parameter and/or condition is restored to acceptable values.

Procedures will be available for NRC review at least 60 days prior to fuel load.



QUESTION 6A.50 (NRC Question 440.77) ✓

(6.3)

List all ECCS valve operators and controls that are located below the maximum flood level following a postulated LOCA or main steam line break. If any are flooded, evaluate the potential consequences of this flooding both for short and long-term ECCS functions and containment isolation. List all control room instrumentation lost following these accidents.

RESPONSE: Air-operated drain valves SIB-UV-322 and 332 are used for relieving piping header pressure to the reactor drain tank after the reactor coolant system (RCS) check valve test, *but are not used during emergency operation.*

An air-operated containment isolation valve CHA-UV-560 is used to isolate the reactor drain tank discharge header. A second isolation valve is located outside containment.

Pressure instruments SIA-PT-390 and SIB-PT-391 are used in conjunction with RCS check valve testing and can also be used for indication of check valve leakage.

No control room instrumentation is lost. *There are no harmful effects seen from*

seen for a long- or short-term flooding of the above items. on for the SIS safety injection system.

6



QUESTION 6A.51 (NRC Question 440.78) ✓

(6.3)

Because of freezing weather conditions, blocking of the vent line on the refueling water tank (RWT) has occurred on at least one operating plant. Describe design bases and features that preclude this condition from occurring in the Palo Verde Plant.

RESPONSE: The refueling water tank (RWT) is provided with an eight-inch vent line that is connected to a common ten-inch header leading to the fuel building normal exhaust duct system. The water within the RWT will be kept above 60F at all times. The vent is located in the uppermost portion of the tank. The vent pipe is routed without piping pockets that could cause the accumulation of moisture. As the design winter ambient temperature at PVNGS is 25F for 24 hours, plugging of the RWT vent line is considered very improbable.

6



QUESTION 6A.52 (NRC Question 440.79) ✓

(6.3)

It is our position that the SIS hotleg injection valves should be locked closed with power removed during normal plant operation in order to prevent premature hotleg injection following a LOCA.

RESPONSE: Two valves in series are provided for each hotleg injection line. Each valve is powered from a separate power supply and is controlled by a keylocked switch in the control room. The design meets the single failure criterion to prevent premature hot leg injection.

6



QUESTION 6A.53 (NRC Question 440.80) ✓ (6.3)

Your sump test program described in Section 6.2.2 is not in sufficient detail. The experimental program must demonstrate that sufficient margin in available NPSH over that required for each pump with all pumps at runout or maximum post-LOCA flow.

The test must demonstrate that the design precludes conditions adverse to safety system operation. Test parameters must include: (1) minimum to maximum containment water level, (2) minimum to maximum safety system flow range in various combinations (this includes transients associated with startup, shutdown, or throttling of a train or pump), (3) random blockage of up to 50 percent of the screens and grids, (4) approach flow for each dominant direction and combinations thereof, and (5) simulation of break flow or drain flow impinging or originating within line of sight of the sump and its approaches.

If adverse conditions are encountered, the model configuration must be revised until an acceptable configuration is developed and demonstrated to perform over the full range of variables.

Since you choose to conduct a model test, provide details of the test program. Include information on the model size, scaling principles utilized, comparison of model parameters to expected post-LOCA conditions, and a discussion on how all possible flow conditions and screen blockages will be considered in the model tests. Whenever a reduced scale model is tested, all tendencies for vortex formation must be suppressed. Rotational flow patterns and surface dimples which might be acceptable in full scale tests, probably would not be accepted in a model program. Model testing must include some in-plant testing to demonstrate experimentally that NPSH margin exists for each pump.

RESPONSE: The test included a complete one-to-one^{scale} modeling of the system. This included various flow conditions and



6
 screen plugging by using a full scale model of the sump, screens, safety injection piping, instruments, and structures in the sump vicinity. Further information on the model study is contained in the transcript to the Containment Systems Independent Design Review submitted under PVNGS transmittal letter ANPP-18147, dated June 4, 1981.

In addition, the NPSH calculation results are summarized below to demonstrate that sufficient margin in available NPSH is provided over that required for each pump.

<u>Pump</u>	<u>Required NPSH</u>	<u>Available NPSH</u>	<u>Margin</u>
HPSI	22 feet	31.7 feet	9.7 feet
LPSI	19 feet	31.8 feet	12.8 feet
CS	26 feet	33.4 feet	7.4 feet

These margins are calculated for simultaneous runout flow for all pumps working simultaneously, which is conservative for the NPSH calculation.



QUESTION 6A.54 (NRC Question 440.81) ✓ (6.3)

During our reviews of license applications we have identified concerns related to the containment sump design and its effect on long-term cooling following a Loss of Coolant Accident (LOCA).

These concerns are related to (1) creation of debris which could potentially block the sump screens and flow passages in the ECCS and the core, (2) inadequate NPSH of the pumps taking suction from the containment sump, (3) air entrainment from streams of water or steam which can cause loss of adequate NPSH, (4) formation of vortices which can cause loss of adequate NPSH, air entrainment and suction of floating debris into the ECCS and (5) inadequate emergency procedures and operator training to enable a correct response to these problems. Pre-operational recirculation tests performed by utilities have consistently identified the need for plant modifications.

The NRC has begun a generic program to resolve this issue. However, more immediate actions are required to assure greater reliability of safety system operation. We therefore require you take the following actions to provide additional assurance that long-term cooling of the reactor core can be achieved and maintained following a postulated LOCA.

1. Establish a procedure to perform an inspection of the containment, and the containment sump area in particular, to identify any materials which have the potential for becoming debris capable of blocking the containment sump when required for recirculation of coolant water. Typically, these materials consist of: plastic bags, step-off pads, health physics instrumentation, welding equipment, scaffolding, metal chips and screws, portable inspection lights, unsecured wood, construction materials and tools as well as other miscellaneous loose equipment. "As licensed" cleanliness should be assured prior to each startup.



This inspection shall be performed at the end of each shut-down as soon as practical before containment isolation.

2. Institute an inspection program according to the requirements of Regulatory Guide 1.82, Item 14. This item addresses inspection of the containment sump components including screens and intake structures.
3. Develop and implement procedures for the operator which address both a possible vortexing problem (with consequent pump cavitation) and sump blockage due to debris. These procedures should address all likely scenarios and should list all instrumentation available to the operator (and its location) to aid in detecting problems which may arise, indications the operator should look for, and operator actions to mitigate these problems.
4. Pipe breaks, drain flow and channeling of spray flow released below or impinging on the containment water surface in the area of the sump can cause a variety of problems; for example, air entrainment, cavitation and vortex formation.

Describe any changes you plan to make to reduce vortical flow in the neighborhood of the sump. Ideally, flow should approach uniformly from all directions.

5. Evaluate the extent to which the containment sump(s) in your plant meet the requirements for each of the items previously identified; namely debris, inadequate NPSH, air entrainment, vortex formation, and operator actions.

The following additional guidance is provided for performing this evaluation.

- 5.1 Refer to the recommendations in Regulatory Guide 1.82 (Section C) which may be of assistance in performing this evaluation.
- 5.2 Provide a drawing showing the location of the drain sump relative to containment sumps.



5.3 Provide the following information with your evaluation of debris:

- a. Provide the size of openings in the fine screens and compare this with the minimum dimensions in the pumps which take suction from the sump (or torus), the minimum dimension in any spray nozzles and in the fuel assemblies in the reactor core or any other line in the recirculation flow path whose size is comparable to or smaller than the sump screen mesh size in order to show that no flow blockage will occur at any point past the screen.
- b. Estimate the extent to which debris could block the trash rack or screens (50 percent limit). If a blockage problem is identified, describe the corrective actions you plan to take (replace insulation, enlarge cages, etc.).
- c. For each type of thermal insulation used in the containment, provide the following information:
 - (1) type of material including composition and density,
 - (2) manufacturer and brand name,
 - (3) method of attachment,
 - (4) location and quantity in containment of each type,
 - (5) an estimate of the tendency of each type to form particles small enough to pass through the fine screen in the suction lines.
- d. Estimate what the effect of these insulation particles would be on the operability and performance of all pumps used for recirculation cooling. Address effects on pump seals and bearings.

RESPONSE:

INSERT A →

~~_____~~

~~_____~~



1. CESSAR section 16.4.5.2.b commits to inspection of the containment prior to establishing containment integrity.
2. CESSAR section 16.4.5.2.c.2 commits to the inspection required by Regulatory Guide 1.82 (Rev. 0) Item 14.
3. Plant procedures will require an operator to periodically check on ECCS performance during long term recirculation cooling using the ECCS. These procedures will provide specific guidance on recognition and mitigation of ECCS performance degradation during recirculation operation. They will also include guidance to alert the operator to the symptoms of inadequate core cooling. Amended section 6.3.1.4.H.2 refers to CESSAR Table 6.3.2-3 which provides a list of the instrumentation available to the operator to monitor ECCS performance.



~~TO BE PROVIDED BY THE OPERATIONS~~

4. No fixed pipes or drains terminate in the vicinity of the sump.

5.1 The PVNGS design fully meets the requirements of NRC Regulatory Guide 1.82, Revision 0.

← 5.2 Figure 6A-4 shows the location of the drain sump relative to the containment sump.

5.3.a. Figure 6A-5 provides the size of openings on the screens. No flow blockage will occur beyond the screen as all openings are larger than the minimum screen size.

5.3.b. The estimated blockage is 20%. The model tests were made for up to ^{95%} ~~20%~~ blockage.

5.3.c(1) Type 304, stainless steel

5.3.c(2) Mirror insulation by Diamond Power Corporation

5.3.c(3) Attached by stainless steel buckles

5.3.c(4) Only mirror insulation is used in the containment except for 400 feet of fiberglass insulation used on 10-in., 8-in., and 6-in. chilled water pipe. The fiberglass insulation is manufactured by the CERTAINTEE Company and is surrounded in every application by a stainless steel jacket.

5.3.c(5) The model test of the containment recirculation sump and screen included modeling various percentages of screen plugging and flow conditions. ^{The maximum screen plugging tested was 95 percent.} ~~The model test report~~ describes in detail various test parameters. The report information has been submitted ^{to the NRC} ~~as part~~ of the Containment Systems Independent Design Review submitted under PVNGS transmittal letter ANPP-18147, dated June 4, 1981. This model test report has shown that a vortex breaking cage



are required.

needs to be installed at the suction pipe. This change will be implemented. No other changes in piping or structures ~~will be made as the tests showed them to be unnecessary.~~ The combination of this testing and the analytical calculations for head loss of piping outside the model's scope, prove that there is adequate NPSH at the safety injection pumps.

5.3.d ~~()~~

~~As the surface area of the screens is 564 sq. ft., 50 percent of this total available area is 282 sq. ft.~~

Should a 10-inch pipe break, it is assumed that approximately 10 feet of the fiberglass insulation would free itself from the stainless steel jacket. That corresponds to approximately 26 sq. ft. of insulation or approximately ~~5~~⁵ percent of the total area ~~of 564~~⁵⁶⁴ sq. ft. No hydraulic degradation is expected at this low level of screen plugging. Insulation particles passing through the screen would have no effect on the operability or ~~the~~ performance of pumps used for recirculation cooling.



440.81

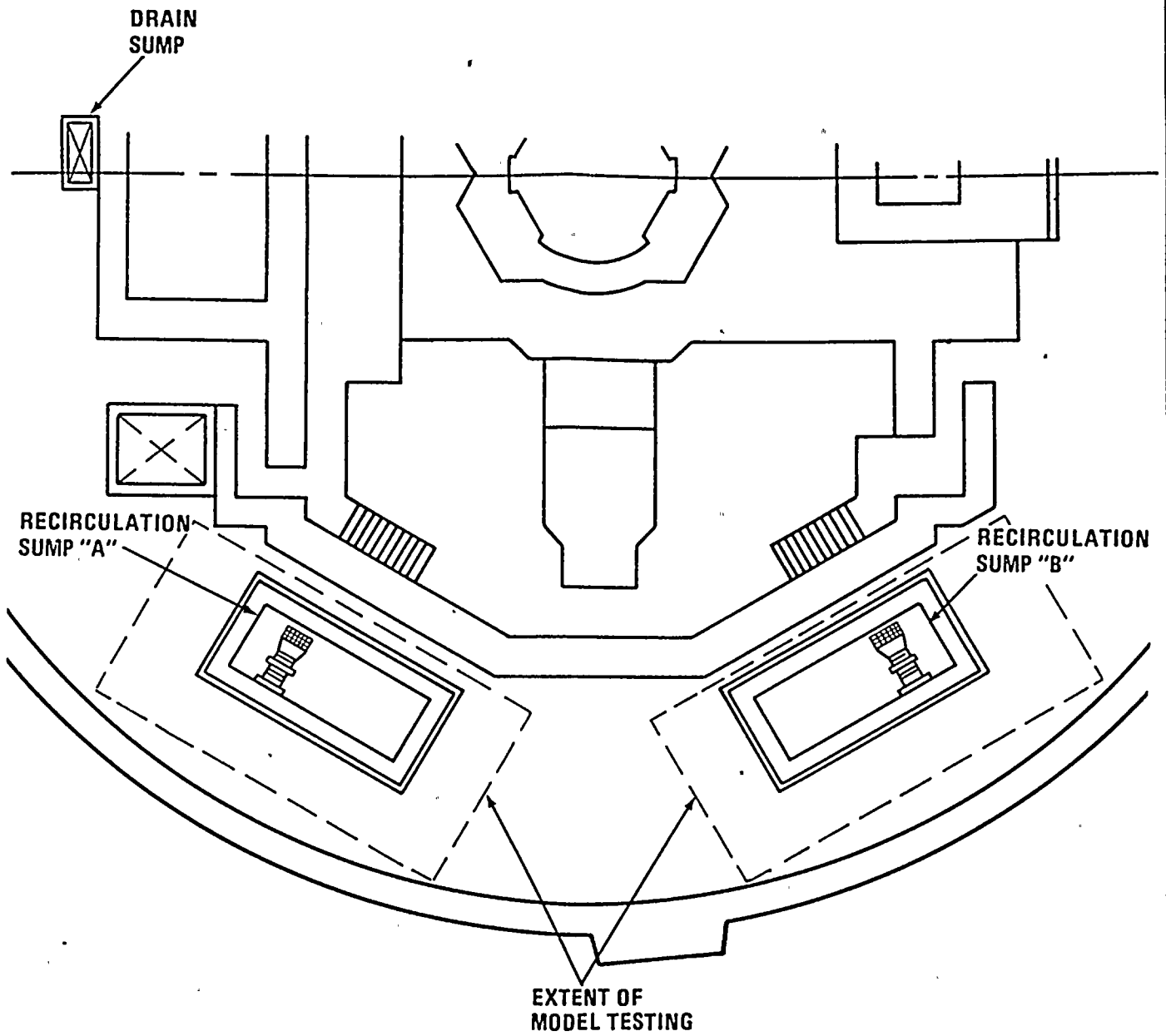

6

	Palo Verde Nuclear Generating Station FSAR
RECIRCULATION SUMPS CONTAINMENT BLDG. EL. 80'	
Figure 6A-4	

September 1981

Amendment 6

08-03-81



440.81

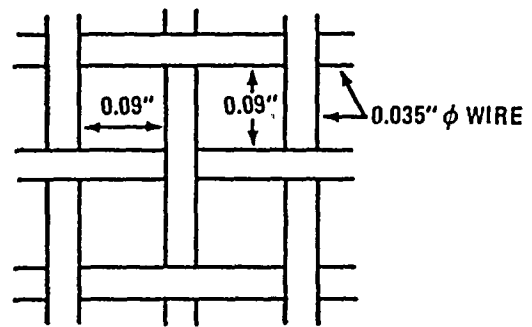
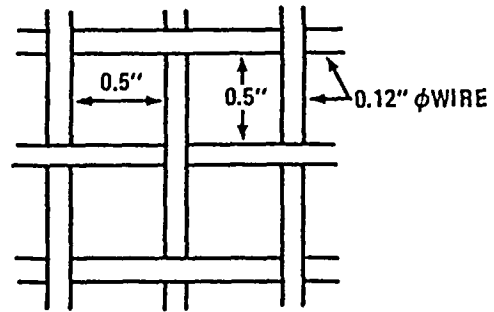
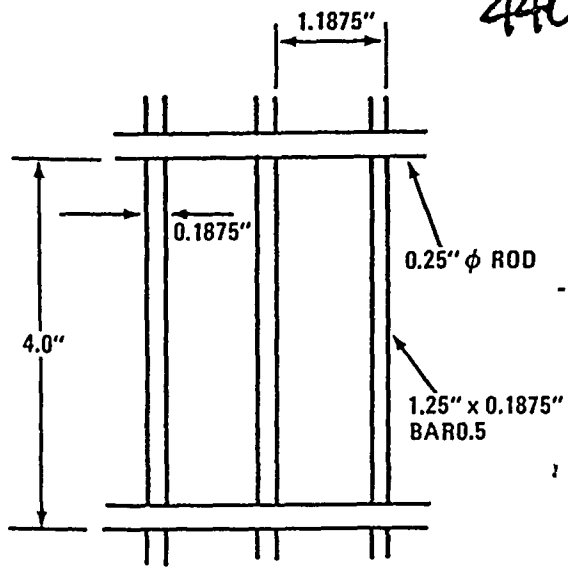
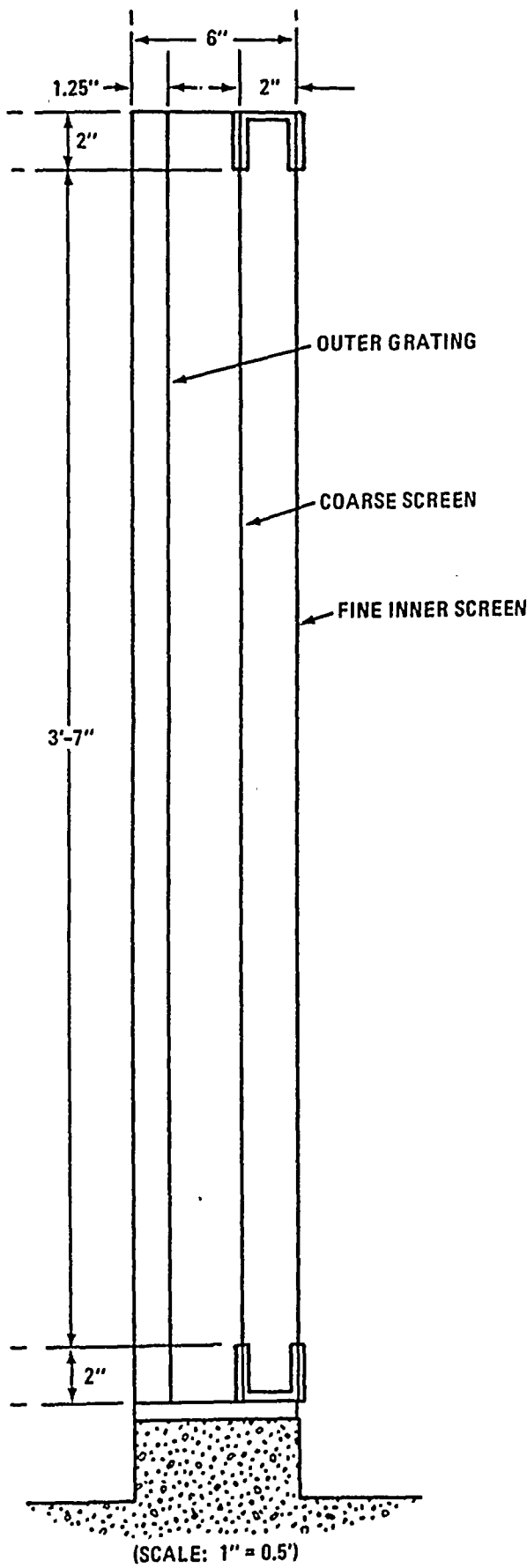

	Palo Verde Nuclear Generating Station FSAR
CONTAINMENT RECIRCULATION SUMP SCREEN DETAIL	
Figure 6A-5	



QUESTION 15A.48 (NRC Question 440.82) ✓ (15.0)

Section 15D.2.2.2 of the CESSAR System 80 FSAR states that the loss of instrument air event impact on the plant systems and components will be addressed in the applicant's FSAR.

Discuss the loss of instrument air for Palo Verde showing that it meets the appropriate acceptance criteria for a moderate frequency event. Causes and potential systems interactions should be addressed and the loss of instrument air should be considered during all phases of reactor operation. Also, present your plans and capability for preoperational or startup tests to substantiate the analyses.

RESPONSE: ^{(8 hours for the atmospheric dump valves).} The nitrogen supply system will support the required instrument air system for one hour on loss of instrument air. This ~~will be done~~ ^{is accomplished} by providing an automatic control valve connecting the nitrogen system to the instrument air system. Depletion of the nitrogen system will not affect any safety related systems.

INSERT A →

ESF air-supplied components normally supplied from the

6



The following list shows the systems which would be affected on loss of instrument air and depletion of the nitrogen supply. Also shown is the position of the air (or nitrogen) supply valve upon depletion of the nitrogen supply.

<u>SYSTEM</u>	<u>FAIL SAFE VALVE POSITION</u>
RCP Seal Injection	Open
RCS Letdown	Closed
CVCS Charging	Closed
Boric Acid Concentrator	Closed
Suction to RDPs	Closed
Gas Stripper	Closed
Pressurizer Sprays	Closed
Steam Bypass to Condenser	Closed
Main Steam Line Drains	Closed
Nitrogen Charging to SITs	Closed
Sulfuric Acid to ESPs	Closed
Letdown Hx Cooling Water	Closed
Turbine Cooling Water	Open
Normal Chilled Water	Closed
Auxiliary Steam System	Closed

Instrument air loss would not incapacitate any safety-related systems or equipment needed for safe shutdown. It would affect the above systems by fail-safe closing or opening (as indicated) of air-operated valves upon air failure and depletion of nitrogen supply.



Question

440.83
(II.B.1)
Palo Verde
only

Your response to Item II.B.1 of NUREG-0737 requirements is not sufficient. Provide the following:

1. Provide diagrams and a description of the vent discharge vicinity. Verify that adequate ventilation is provided and that equipment in this area is capable of withstanding discharge of gases and liquids from the vents.
2. What size are the flow limiting orifices and what are the calculated flow rates through the vent system for both gas mixtures and liquids at operating pressures?
3. Provide drawings of the piping system from the vessel head and pressurizer through the discharge paths. In particular, show the location of the solenoid operated valves and consider potential missile hazards from them.

Refer to PVNGS Lessons Learned Implementation Report (LLIR)

RESPONSE:

1. ~~See~~ *See* Figure II.B.1-1 which will be provided in a future LLIR amendment.

Line RC-148-BCBA-1" discharges into an open area near steam generator number 1. This area is not restricted in any way. This occurs at elevation 158'6" at the north side of the containment. There is adequate ventilation and there is no ^{eq.} equipment in the area of the discharge that could be affected by system operation.

2. The flow limiting orifices have a round opening of 7/32".

Anticipated flow rate is about 500 scfm.

3. The system was reviewed on the plant ^{scale} model and it was found that there ^{were} ~~was~~ no credible missiles ^{hazards, and no safety-related equipment} ~~are closed~~ ^{are closed} during normal operation via keylock switches in the main control room.

~~The solenoid-operated valves are closed during normal operation via keylock switches in the main control room.~~

INSERT A



INSERT A to page 5A-1

440.83

To minimize the possibility of common mode failure of solenoid operated valves to shut when de-energized, the operation procedure for the Reactor Coolant Gas Vent System (RCGVS) will require that when ~~power is available from~~^{ave available} both Trains A and B, that one valve powered from Train A and one valve powered from Train B will be used to complete a vent path.



DOCUMENT/ PAGE PULLED

ANO. 8109020263

NO. OF PAGES 1 page

REASON:

PAGE ILLEGIBLE:

HARD COPY FILED AT: PDR CF

OTHER: _____

BETTER COPY REQUESTED ON _____

PAGE TOO LARGE TO FILM.

HARD COPY FILED AT: PDR

CF

OTHER _____

FILMED ON APERTURE CARD NO. _____ 01



~~RESPONSES TO AIC QUESTIONS~~

Question

440.84

Your response to Item II.K.3.17 of NUREG0737 is not complete. Provide a commitment that you will establish a program prior to fuel loading for data collection on information regarding ECCS outages. The information will contain: (1) outage dates and duration of outages; (2) cause of the outages; (3) EECS systems or components involved in the outage; and (4) collective action taken.

PVNGS Response: ~~amended~~ amended Section II.K.3.17 of LLIR. ~~amended~~

The response will be provided in)



PVNGS
LLIR

DRAFT

DRAFT

II.K.3.17 REPORT ON OUTAGES OF EMERGENCY CORE COOLING SYSTEMS
LICENSEE REPORT AND PROPOSED TECHNICAL SPECIFIC
CHANGES

Position

Several components of the emergency core cooling (ECC) system are permitted by technical specifications to have substantial outage times (e.g., 72 hours for one diesel-generator; 14 days for the HPCI system). In addition, there are no cumulative outage time limitations for ECC systems. Licensees should submit a report detailing outage dates and lengths of outages for all ECC systems for the last 5 years of operation. The report should also include the causes of the outages (e.g., controller failures, spurious isolation).

PVNGS Evaluation

Arizona Public Service Company will ^{establish a program} ~~establish a program~~ for data collection of outage dates and lengths of outages, ~~and~~

~~and~~ ~~include~~ ~~the~~ ~~cause~~ ~~of~~ ~~the~~ ~~outage~~, cause of the outage, ECCS systems or components involved in the outage, and the corrective action taken for ECC systems prior to fuel load of Unit 1.



QUESTION 440.85

440.85
(II.K.3.25)
Palo Verde
only

Your response to Item II.K.3.25 of NUREG-0737 states that the reactor coolant pump normal cooling water system (nonsafety grade nuclear cooling water system) is backed up by the essential seals during loss of offsite AC power. Describe the manual action involved and the manual action time required for transferring the cooling water supplies. Also, state that your operating procedure allows enough time to restore the cooling water supplies to the RCP seals before you trip the RCPs. After the RCP trip, you may still need essential cooling water supply to the RCP seals.

RESPONSE: Upon loss of offsite power, train A of the essential cooling water system is automatically aligned. This alignment is based on the sequencing of loads on the emergency diesel generator.



440.86)

QUESTION 6A.55 (NRC Question ~~440.77~~) (6.3)

Expand your interface requirements in Section 6.3.1.3 to include the requirement of power locked out on the SIS hotleg injection valves in order to prevent premature hotleg injection following a LOCA.

RESPONSE: The response will be provided on the CESSAR docket. In addition, as shown on FSAR Figure 6.3-1, the hotleg injection isolation valves (SIA-HV604, 321, SIB-HV609, 331) are powered from separate power supplies.



Question 440.87

~~440.87) SITE 80-470-CESSAR~~
QUESTION 5A.13 (NRC Question ~~440-82-173~~ (5.41 and 9.2.2)

If the RCP tests demonstrate that the RCPs are capable to operate with loss of component cooling water supply for longer than 30 minutes without loss of function and the need for operator protective action, safety grade instrumentation to detect the loss of component cooling water to the RCPs and to alarm the operator in the control room should be provided.

The entire instrumentation system, including audible and visual status indicators for loss of component cooling water should meet the requirements of IEEE std. 279-1971/1974. The above requirements should be specified in the applicable section (e.g., Section 5.4.1 or 9.2.2) of CESSAR System 80 FSAR as interface requirements.

RESPONSE: Redundant Class IE flow transmitters are provided for each nuclear cooling water supply to the RCP ^{component} coolers. This instrumentation provides visual and audible annunciation to the control room operator on loss of nuclear cooling water flow. The redundant Class IE annunciators are discussed in section 7.6 and meet the requirements of IEEE Standard 279-1971.

[5A-8]





USE DIMENSION
LINE WEIGHT
(TYP.)

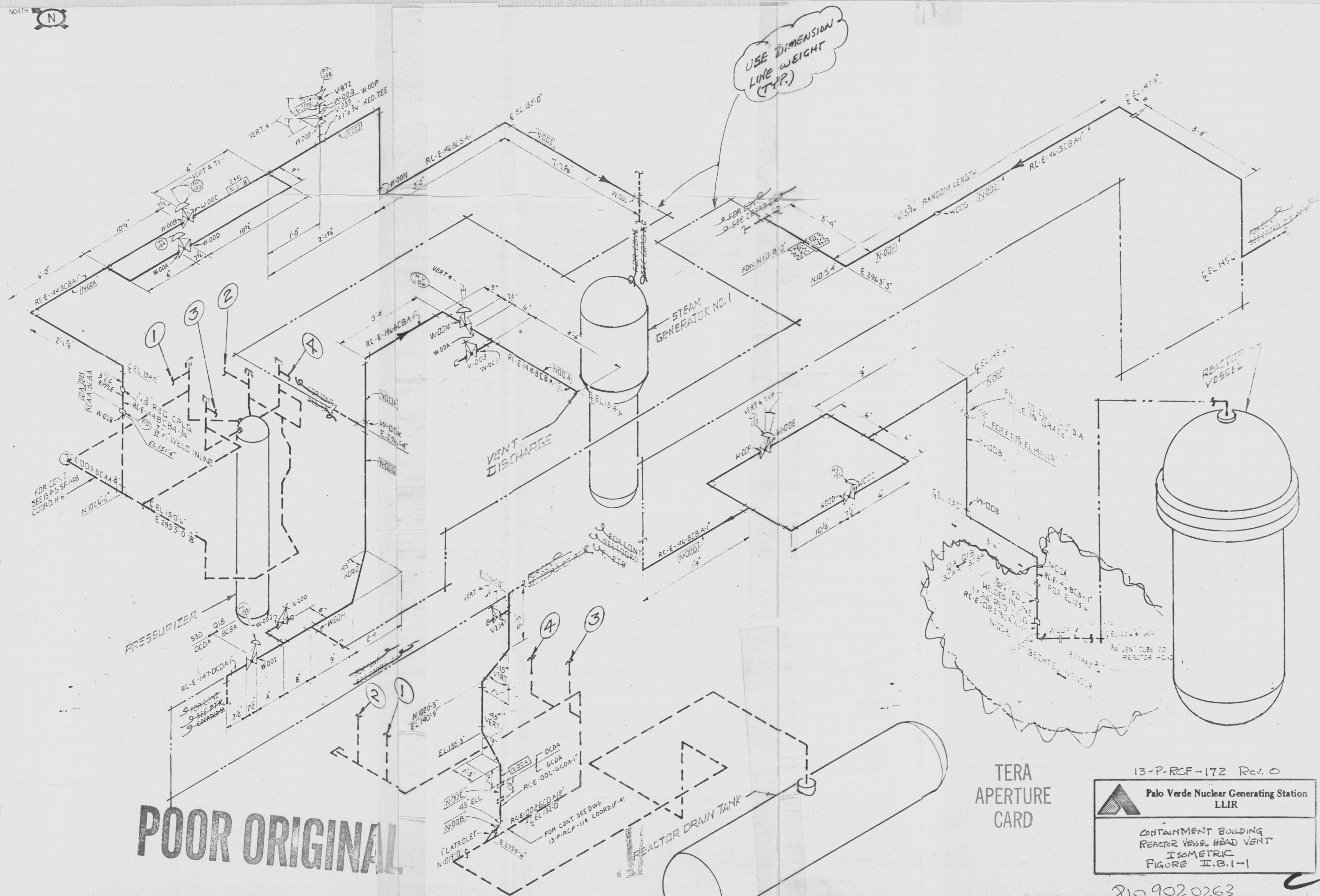

POOR ORIGINAL

TERA
APERTURE
CARD

13-P-RCF-172 Rev. 0

Palo Verde Nuclear Generating Station
LLIR

CONTAINMENT BUILDING
REACTOR VESSEL HEAD VENT
ISOMETRIC
FIGURE II.B.1-1

810 902 0263