

WASHINGTON PUBLIC POWER SUPPLY SYSTEM

NUCLEAR PLANT NO. 2

FEEDWATER NOZZLE INSPECTION REPORT

FOR REFUELING OUTAGE RF88A

SPRING, 1988

Prepared by: DP Roman Nov 15, 1988
ISI Engineer Date

Reviewed by: TFH CR 11/21/88
Manager, Engineering Systems Support Date

SM ST Howard 12/3/88
Manager, WNP-2 Generation Engineering Date

ES RL 12/14/88
Manager, Plant Technical Date

Approved by: CM Powell 12/14/88
Plant Manager Date



SUMMARY

This report addresses reactor vessel feedwater nozzle inspections for WNP-2 performed during the third refueling outage (April 1988). This report is required by NUREG-0619, Section 4.4.3.

Ultrasonic examination of one reactor feedwater nozzle was performed during the refueling outage. No recordable indications were found. The Plant had experienced 14 startup/shutdown cycles during this inspection period.

At the start of this period the low flow ("startup") valve was replaced by two valves. This modification allows startup and low power operation feedwater control by these valves instead of varying reactor feed pump turbine speed. This minimized feedwater nozzle thermal cycling during the period.

The Supply System plans to continue its augmented feedwater nozzle inspection at the next refueling outage as committed in the WNP-2 ISI Program Plan. This commitment requires one feedwater nozzle bore, inner radius and safe-end to be ultrasonically examined from the reactor outside diameter (OD) at the next scheduled refueling outage (April, 1989).

NDE EXAMINATION

During WNP-2 refueling outage RF88A, the Supply System performed ultrasonic examination of one reactor feedwater nozzle safe-end, bore and inner radius from the vessel OD. This examination satisfies part of WNP-2's commitment described in FSAR Section 5.2.4.10 and Inservice Inspection Program Plan Section 5.3.2 to ultrasonically examine one feedwater nozzle from the OD each refueling outage for the first six refueling outages.

The Supply System has developed an angle beam shear wave technique that is unique to the WNP-2 feedwater nozzle design. The procedure was qualified on the WNP-2 feedwater nozzle mock-up which is a feedwater nozzle from the scrapped Douglas Point Unit 1 reactor vessel. The inner radius, Zone 1, of the nozzle is scanned using a 72 degree angle transducer. The inner radius, Zone 2, and bore region, Zone 3, are scanned using a 25 degree angle transducer. The procedure, QCI 6-4, was revised prior to the examination to clarify the scanning technique. The changes were verified on the feedwater nozzle mock-up. The procedures used, QCI 6-4, Revision 4 and QCI 6-13, Revision 4, are contained in Appendix I to this report.

Calibration data for reactor feedwater nozzle inner radius examinations have been predetermined using the WNP-2 feedwater nozzle mock-up. This allows the examiner to use the reactor vessel calibration block representing the shell course containing the feedwater nozzle for calibration. The transfer data is contained in Table I of procedure QCI 6-4. Indications that exceed 25% full screen height (FSH) are recorded and indications that exceed 50% FSH are evaluated.



The examinations were performed by Supply System and Lambert MacGill Thomas examiners certified to either Level II or Level III UT.

No recordable indications were found. The Supply System has examined, using the same UT technique, two other RFW nozzles during previous refueling outages. No recordable indications were found in either nozzle.

Total examiner radiation dose was less than 0.250 Man Rem.

LEAKAGE MONITORING

WNP-2 does not have on-line leakage monitoring for the RFW sparger. See FSAR section 5.2.4.10.

SYSTEM AND PROCEDURE CHANGES THAT AFFECT FEEDWATER FLOW

During refueling outage RF87A, Spring, 1987, the low flow ("startup") valve, RFW-FCV-10, was replaced with two valves. This change allows feedwater control at startup and low power to minimize thermal cycles on the feedwater nozzle without varying the reactor feed drive turbine speed. The later method had been used since startup when it was discovered the original startup valve did not meet its required function (see reference 1).

This modification has performed successfully since installation to minimize thermal cycles on the feedwater nozzles. This modification improved the feedwater control at startup and lower power.

STARTUP/SHUTDOWN CYCLES

WNP-2 experienced fourteen (14) startup/shutdown cycles since the last feedwater nozzle inspection report (reference 2). This brings the total cycles since initial heat up (April, 1984) to 70. The data for outage RF88A was compiled from the 1987 Annual Operations Report and Monthly Core Energy Output worksheets.

NEXT SCHEDULED EXAMINATIONS

The Supply System will perform an ultrasonic examination from the outside diameter (OD) of the reactor vessel on one reactor feedwater nozzle inner radius, bore and safe-end per the commitment in FSAR Section 5.2.4.10 and the Inservice Inspection Program Plan Section 5.3.2 during the refueling outage scheduled for Spring 1989.

REFERENCES

1. Feedwater Nozzle Inspection Report for Refueling Outage RF86A, issued November 25, 1986.

APPENDIX I

Procedure QCI 6-4, Revision 4

Procedure QCI 6-13, Revision 4



WASHINGTON PUBLIC POWER
SUPPLY SYSTEM

NDE & I INSTRUCTION

NO.	QCI 6-4
REV. NO.	4
EFFECTIVE DATE	4/26/88
QUALITY AFFECTING	<input checked="" type="checkbox"/> YES <input type="checkbox"/> NO

TITLE	ULTRASONIC EXAMINATION BWR NOZZLE INNER RADIUS
-------	--

1.0 PURPOSE AND SCOPE

- 1.1 This procedure defines the requirements for manual, pulse-echo ultrasonic examination of the BWR nozzle inner radius, (Zones 1, 2, and 3), ASME Section XI, Category B-D. Scanning by this procedure is done from the reactor vessel O.D. wall and nozzle surfaces using refracted shear wave search units. Figure 1 illustrates the Zones which can be effectively scanned from the outside surfaces of the vessel plate and nozzle.
- 1.2 This procedure covers the angle beam shear wave technique that is unique to the nozzle design. Specific refraction angles have been determined by individual nozzle geometry as depicted in Figures 2, 3 and 4.
- 1.3 This instruction is intended to meet the requirements of Sections V and XI of the ASME Boiler and Pressure Vessel Code (1980 with Addenda through Winter 1980).
- 1.4 BWR Calibration Data listed in Table I have been predetermined from the Supply System's feedwater nozzle mockup so the qualified examiner need only use the vessel calibration block representing the shell course containing the nozzle.

2.0 DEFINITIONS

None.

3.0 REQUIREMENTS

3.1 Personnel Qualifications

- 3.1.1 Personnel performing examinations to the requirements of this instruction shall be a certified to at least Level II, in ultrasonics in accordance with the requirements of Reference 6.2 and (b) below. Supply System personnel shall be (a) certified to at least Level II in accordance with Reference 6.3 and (b) qualified using the Supply System BWR feedwater nozzle mockup and this ultrasonic examination procedure.

WRITTEN BY <i>[Signature]</i>	CHECKED BY/DATE <i>[Signature]</i>	LEVEL III/DATE <i>[Signature]</i> 4-22-88
DEPT. APPROVAL/DATE <i>[Signature]</i> 4-26-88	SUPERSEDES ISSUE Revision 3	PAGE 1 of 21

3.1.2 Personnel not specifically qualified on the BWR feedwater nozzle mock-up, but designated as Trainee, Level I, II or III UT may assist a qualified examiner in performance of examinations to this instruction.

3.1.3 At least one person responsible for reviewing the results of the ultrasonic examination shall be a Supply System person certified as an ultrasonic Level III in accordance with Reference 6.3 in addition to meeting the requirements of (b) above.

3.2 Radial Clearance

The thermal insulation should be clear of the nozzle and vessel to create a free space 12 inches out from the nozzle cylinder outer surface.

3.3 Equipment

3.3.1 The pulse-echo, ultrasonic, flaw detection instrument shall be equipped with a fine gain or attenuation control graduated in units no larger than 2 dB. Instruments considered acceptable for this examination are listed below; however, other instruments may be used if the model type has been qualified.

Krautkramer USIP-11, USL-48, USD-10
Nortec NDT 131 or 131D, 132D

3.3.2 Single element ceramic transducers, having an area of .44 to 1.0 square inch, with a nominal frequency of 2.25 MH shall be used with specific wedges, Figure 5. The refracted angle within the material shall be within the limits shown in Table I. Additionally, data may be taken with other sizes, frequencies, and angles, after completing the examination to the above requirements.

3.3.3 Ultragel II or its equivalent shall be used as the liquid couplant.

3.3.4 The vessel calibration standard listed in Table I shall be used. This standard corresponds to the shell thickness containing the subject nozzle.

3.3.5 IIW-2 ROMPAS or modified Type DC (square ended semicircle) sweep calibration reference blocks.

3.3.6 Flashlight for reading instrument control knobs.

3.4 Surface Preparation

The contact surface shall be clean and free of dirt, dust, weld spatter, loose paint, or other material which would interfere with free movement of the transducer or impair transmission of ultrasonic energy into the material.

3.5 Scanning Speed Limit

The scanning speed shall not exceed 3 inches per second.

3.6 Nozzle Identification

Prior to the examination, the nozzles shall be marked and identified in accordance with a nozzle marking plan as illustrated in Figure 6. Sanford's "Sharpie" black tip marker is the accepted pen device.

3.7 General Requirements for Calibration

Calibration shall include the complete ultrasonic examination system. Any change in couplants, cables, or ultrasonic instruments shall be cause for recalibration. Sweep calibrations may be made with a standard angle beam wedge using the IIW or similar curved block, and must be representative of the metal path expected for the zone to be examined, reference Table I.

3.7.1 Instrument Calibration - Prior to the initiation of scheduled examinations, the ultrasonic instrument shall be checked for amplitude control linearity per paragraphs 3.7.2 and 3.7.3, respectively.

3.7.2 Amplitude Linearity Check - An angle beam search unit shall be positioned on a calibration block and signals obtained from two reflectors. The search unit position shall be adjusted to give a 2:1 ratio of amplitudes between the two reflectors. The gain control (sensitivity) shall be adjusted and the larger signal brought to 80% of full screen height (FSH), adjusting position if necessary to maintain the 2:1 signal ratio. Without moving the search unit, adjust the gain control to successively set the larger signal from 100% to 20% FSH in 10% increments or 2 dB steps. The smaller amplitude must be 50% of the larger amplitude within 5% of FSH. Instruments that do not meet these requirements shall not be used.

3.7.3 Amplitude Control Linearity Check - The angle beam search unit shall be positioned on a calibration block and a peaked signal amplitude obtained from a hole or notch. The indication shall be brought as near as possible to 80% FSH with



the dB control. If necessary, the final adjustment to 80% FSH is made with the variable gain control or dB switch. Using only the dB control, the dB changes indicated below shall be made and the resulting amplitude compared with the allowable amplitude limits as specified below. Instruments that do not meet these limits shall not be used. The procedure shall be repeated for 40% and 20% FSH amplitudes.

<u>Initial Amplitude</u>	<u>dB Control</u>	<u>Amplitude Limits</u>
Set of % FSH	Change	(% FSH)
80	- 6	32 to 48
80	-12	16 to 24
40	+ 6	64 to 96
20	+12	64 to 96

3.7.4 Recalibration (Sweep Only) - If the indication from the calibration reflector has moved on the sweep line more than one inch of metal path, correct the sweep range calibration and note the correction on the calibration data sheet. If recordable reflectors are noted on the examination data sheets, those data sheets shall be voided. A new calibration shall be made and recorded, and the voided examination areas shall be re-examined.

3.7.5 Recalibration (Amplitude Only) - If the amplitude of the calibration notch has changed by more than 10% FSH when a check is made on the reference block, all data sheets since the last positive calibration check shall be marked void. A new calibration shall be recorded and the voided examination areas re-examined. The voided sheets may be discarded.

Calibration shall be performed at the beginning of each series of examinations. A calibration verification shall be made at intervals not exceeding four hours during the examinations.

4.0 CALIBRATION AND EXAMINATION

4.1 Sweep Calibration

An initial instrument sweep calibration shall be made for shear wave velocity by using the examination search unit with a conventional angle beam shear wave wedge and the IIW, Rompas or modified DC type curved calibration block. Sweep calibration data is listed in



Table I for each nozzle. The oscilloscope's screen shall read directly in inches of metal path and the data entered on the calibration data sheet, Figure 7.

- 4.1.1 Zone 1 - Using a Rompas block, direct the ultrasonic beam toward the large radius, with the exit point of the transducer at the radius center mark on the block, maximize the CRT signals by moving the transducer forward and back. Adjust the "Range" and "Delay" controls until the first reflection signal is at "2" on the horizontal graticule line on the CRT and the following signals appear at "5" and "8". Lock the range control knob and delay the signal at "8" to zero position. Signals should now appear at zero, 3, 6 and 9. Next, delay the signal at 6 to zero. Signals should again appear at zero, 3, 6 and 9. If they do not, make minor adjustments so they do. The CRT is now calibrated for 14 to 24 inches of metal path.
- 4.1.2 Zone 2 - Using the transducer with the convex 25° shear wedge, obtain peaked signals from the 1/2 to 3/4 "T" holes in calibration block No. 120. Adjust the range and sweep to obtain reflection signals at positions 3.5 and 5.4. Delay the signal at 5.4 to the 0.4 position. The CRT is now calibrated for 5 to 15 inches of metal path.
- 4.1.3 Zone 3 - Using the transducer with the flat 25° shear wedge, calibrate as in 4.1.2.
- 4.2 Amplitude Calibration. Basic calibration shall be established with sufficient gain so that 2X scanning can be performed without changing the variable gain control. To determine the basic sensitivity level of 1X, the search unit shall be held on the applicable vessel calibration standard, with the echo amplitude from the side drilled hole at 3/4 T maximized. The gain controls shall now be adjusted so that the echo amplitude is brought to 50% FSH. This shall be the primary reference level.

CAUTION: Care must be exercised during calibration to assure the shear wave component is used for calibration since there is also a strong longitudinal wave component generated by the angle beam transducer, especially for Zone 2 and 3 calibration. A peaked shear wave signal from the 3/4 T hole should appear at approximately 5.7 inches metal path when the transducer is approximately 2-3/8 inches surface distance from a line normal to the hole centerline. The refracted longitudinal wave should produce a peaked signal at approximately 4-3/4 inch metal path at a surface distance of 6-1/2 inches.

4.3 Examination

A Level II or III UT examiner shall view the CRT display during the examination. A record of each nozzle inner radius examination shall be made on examination data sheets (Figure 8), which shall be numbered in sequence with calibration data sheets. Scanning shall be performed at 2X above the primary gain level (1X). Measurement and recording of ultrasonic indications shall be done at the 1X level.

Zone - 1

The inner radius Zone 1 shall be scanned in two directions from the vessel plate as shown in Figure 9. Scanning shall progress circumferentially around the nozzle using the moving azimuth technique. The operator shall occasionally rotate the wedge toward the bore axis to obtain a direct reflection signal from the inner radius as a check to confirm penetration. For the primary technique, Zone 1 scan boundaries extend from the end of the blend radius to a distance 9.0 inches out on the shell wall. A secondary technique may be used in addition to the moving azimuth technique, the scanning shall follow a continuous line around the nozzle using a fixed azimuth. A minimum of three scans shall be made as shown in Figure 9 (0.5 in. overlap). The movable pointer on the transducer wedge shall be positioned in the groove marked "CCH" for scanning counter clockwise and "CH" for scanning clockwise. The pointer shall be aimed at the nozzle bore axis during scanning to the extent practicable. The examiner shall reference Figure 10 for transducer orientation.

Zone - 2

The inner surface of the nozzle shall be scanned from the exterior surface of the nozzle using the appropriate search units in two directions: clockwise (CH) and counterclockwise (CCH) (Figure 11). A circumferential scanning pattern spaced at intervals not exceeding 0.25 in. (3/4 in. overlap) shall be followed around the nozzle body to obtain full coverage of the inner surface Zone 2.

Zone - 3

The nozzle forging and the inside bore shall be examined to the maximum extent possible using the cylindrical surface for scanning (Figure 12). The scan path of the search unit shall overlap the adjacent scan by a minimum of 0.50 inch. The search unit shall be scanned circumferentially around the nozzle forging so the angle beam shear wave covers all 360° of the circumference in both the clockwise and counterclockwise directions.

4.4 Data Recording

Indications in the region of the blend radius which have an amplitude greater than 50% FSH at the 2X scanning level and which travel in time position on the CRT shall be investigated to determine maximum amplitude.

Indications in the region of the blend radius which exceed 25% FSH at the primary reference level (1X) and which travel in time position on the CRT, shall be recorded on the examination data sheet. Report signal amplitude in % FSH, metal path in inches, search unit direction as clockwise (CW) or counterclockwise (CCW), and search unit position.

4.5 Reference Points for Physical Measurement

Reference points for physical measurement of azimuth shall be in accordance with the nozzle reference plan shown in Figures 10, 11, and 12.

4.6 CRT Display Photos

Photos of the CRT display shall be taken at the option of the Level III Examiner to further document the ultrasonic signal character. Pertinent data shown below shall be recorded on the back of each photo.

1. Report No.
2. ISI Drawing No.
3. Zone No.
4. Sweep Distance
5. Indication No.

5.0 DATA PROCESSING

5.1 The recorded data shall be reviewed by a level III Examiner to determine if additional examination and/or interpretation is required.

5.2 Recorded indications shall be plotted on a scale no less than quarter size and reviewed by the Level III Examiner.

6.0 REFERENCE

6.1 American Society of Mechanical Engineers Boiler and Pressure Vessel Code, 1977 Edition through Summer 1978 Addenda.

6.1.1 Section XI - "Rules for Inservice Inspection of Nuclear Power Plant Components".



6.1.2 Section V - Nondestructive Examination".

- 6.2 American Society for Nondestructive Testing, June 1975 Edition. Recommended Practice SNT-TC-1A "Nondestructive Testing Personnel Qualification and Certification".
- 6.3 The Supply System "Program Manual for Qualification and Certification of Examination, Testing and Inspection Personnel WMC-034".
- 6.4 Nozzle forging drawings - General Electric/CBI Nuclear

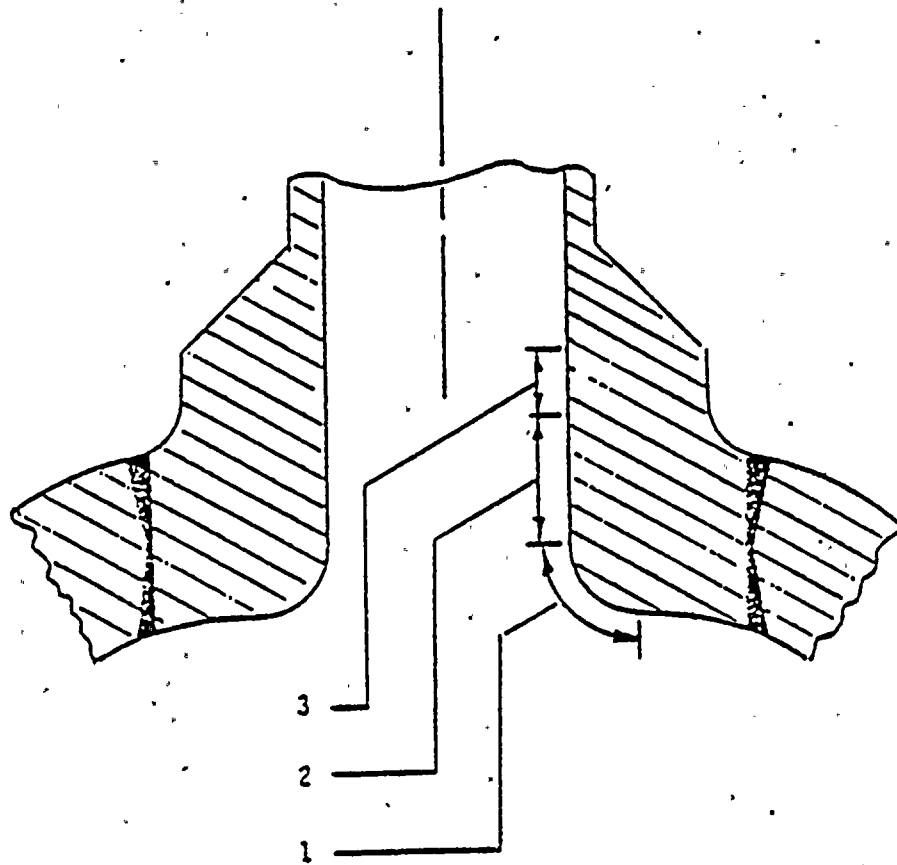

TABLE I
ULTRASONIC CALIBRATION DATA FOR
EXAMINATION OF BWR NOZZLE INNER RADII

NOZZLE TYPE - N4 FEEDWATER

	ACOUSTIC ANGLES DEGREES ¹			CRT DISPLAYED SWEEP	CAL STANDARD #	TRANSFER SENSITIVITY dB GAIN INCREASE
	A	B	C			
Zone 1	22	70	70	14" to 24"	UT 120 ²	0
Zone 2	22	25 ³	63-70	5" to 15"	UT 120	12
Zone 3	0-10	25	63	5" to 15"	UT 120	12

1. See Figures 2A, 2B, 3 and 4
2. The 5/16 in. dia., 3/4 T hole (5.06 in below the contact surface) shall be used for calibration.
3. Convex shoe
4. Gain setting for 50% FSH indication is 6 dB less for RFW nozzle mock-up notch (Notch A) than for 3/4 T-hole of calibration standard UT-120. Therefore, as a conservative measure, the 3/4 T-hole gain setting has been accepted as the primary gain level.



NOZZLE EXAMINATION ZONES

FIGURE 1

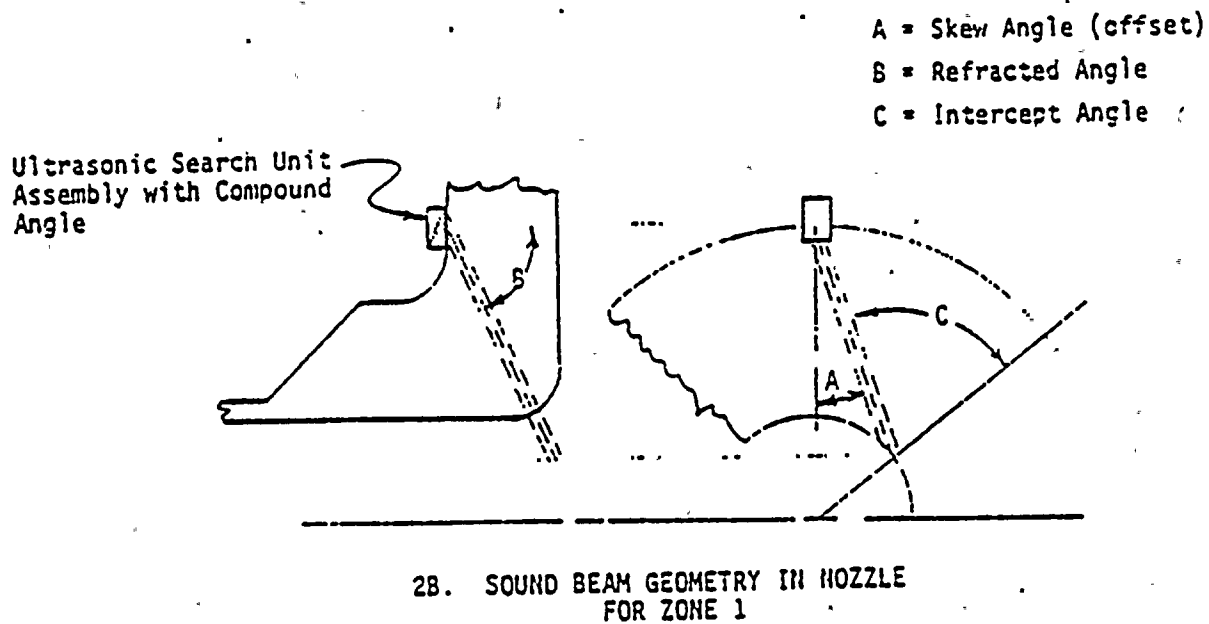
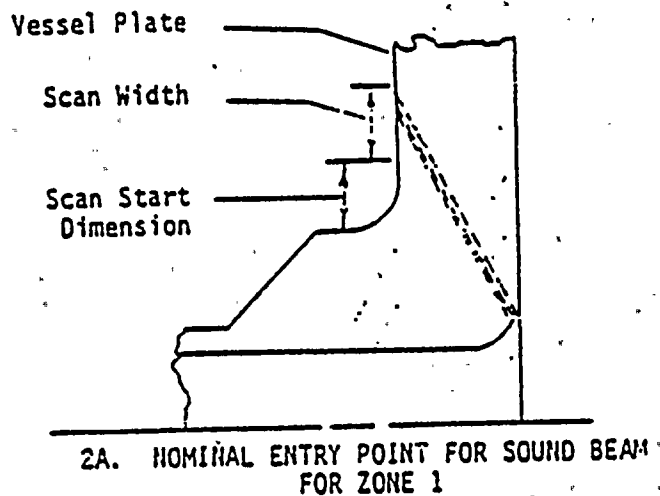

FIGURES 2A and 2B



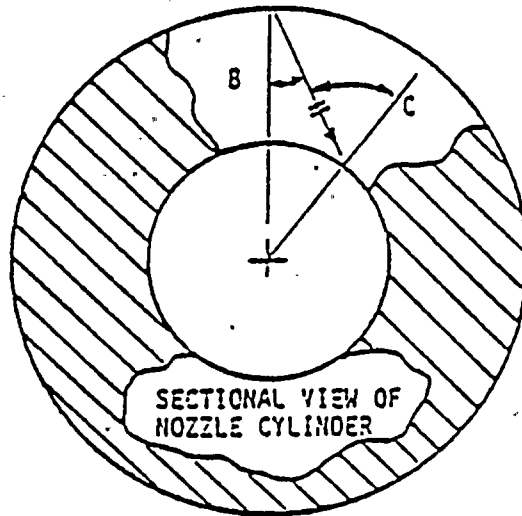
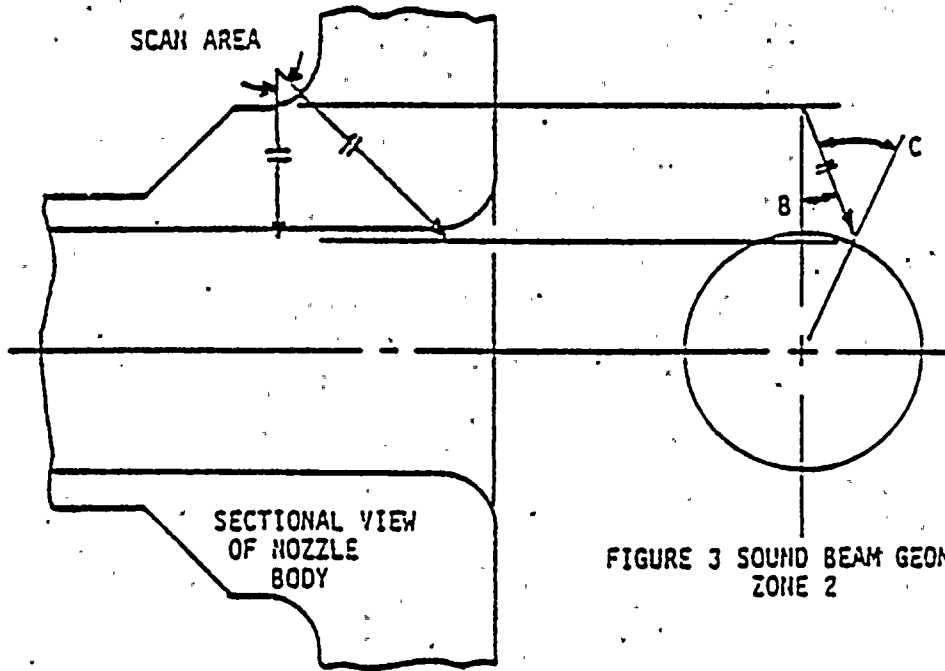

FIGURES 3 and 4

SIDE VIEWS

END VIEWS

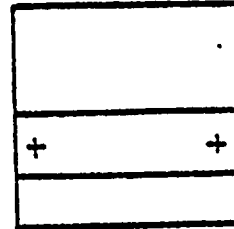
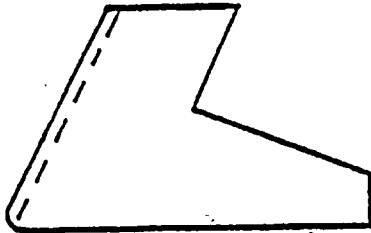

ZONE 1, FLAT CONTACT SURFACE

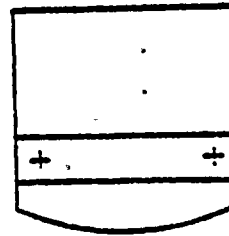
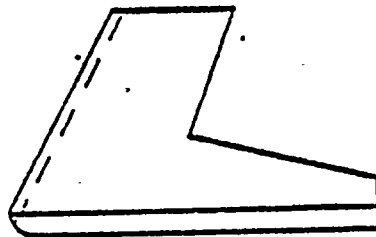

ZONE 2, CONVEX CONTACT SURFACE

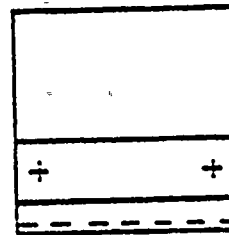
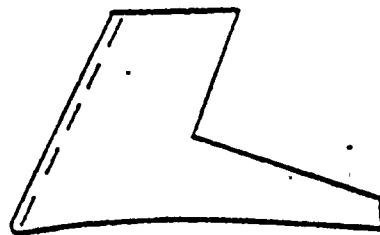

ZONE 3, CONCAVE CONTACT SURFACE

FIGURE 5 TRANSDUCER WEDGE CONFIGURATIONS

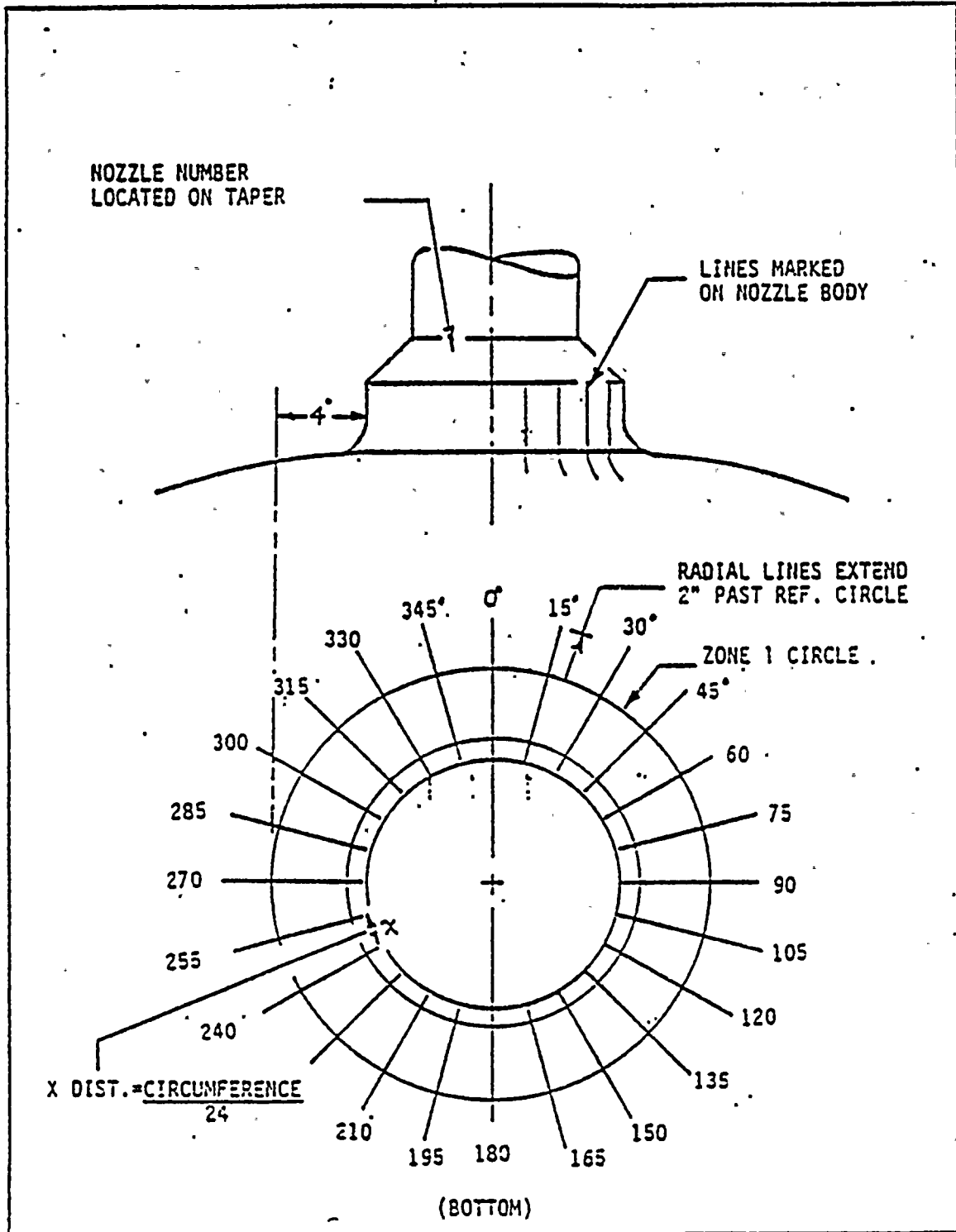

FIGURE 6 NOZZLE MARKING PLAN



ULTRASONIC CALIBRATION SHEET

PROJECT:				SYSTEM:				SHEET NO.:													
EXAMINER:				LEVEL:				DATE:				THERMOMETER S/N:									
EXAMINER:				LEVEL:				INSTRUCTION NO.:				REVISION:									
CALIBRATION STANDARD				CALIBRATION STANDARD SIMULATOR				TRANSDUCER				CABLE TYPE _____									
SERIAL NUMBER _____				S/N _____ TEMP _____ °F				S/N _____ WAVE MODE _____				LENGTH _____									
THICKNESS _____				AMP _____ SWEEP _____ IN.				SIZE _____ FREQ _____ MHz				COUPLANT _____									
TEMPERATURE _____ °F				GAIN IN db _____				ACTUAL ANGLE _____				BATCH NO. _____									
CHART RECORDER TYPE:				S/N:				UT INSTRUMENT TYPE:				S/N:									
INSTRUMENT CALIBRATION																					
PREVIOUSLY PERFORMED ON CALIBRATION SHEET NUMBER _____																					
SCREEN HEIGHT LINEARITY FOR CONTINUOUS GAIN CONTROL						SCREEN HEIGHT LINEARITY FOR 2db STEP GAIN CONTROL						AMPLITUDE CONTROL LINEARITY									
												AMPLITUDE %		80		60		40		20	
HIGH 100 90 80 70 60 50 40 30 20						db +2 0 -2 -4 -6 -8 -10 -12 -14						db CHANGE		-6		-12		+6		+12	
40						HIGH 80						READING %									
						LOW 40						LIMITS %		32-48		16-24		64-96		64-96	
INITIAL CAL TIME:				SYSTEM CALIBRATION				FINAL CAL TIME:													
INSTRUMENT SETTINGS				REFLECTORS				AMPLITUDE %FSH				SWEEP READING IN INCHES				<div style="display: flex; justify-content: space-between;"> <div style="width: 45%;"> <p style="font-size: 2em; opacity: 0.5; transform: rotate(-45deg);">SAMPLE</p> </div> <div style="width: 45%;"> <p style="text-align: center;">SCREEN DAC PRESENTATION</p> <p style="text-align: center;">FULL SCREEN SWEEP _____ IN.</p> </div> </div>					
COARSE RANGE -				/B NODE																	
COARSE DELAY -				/B NODE																	
RANGE CALIB -				/B NODE																	
DELAY CALIB -				/B NODE																	
FREQUENCY -				/B NODE																	
GAIN IN db -				/B NODE																	
DAMPING -				/B NODE																	
REJECT -				SKR db																	
FILTER -				SEARCH UNIT ORIENTATION				<input type="checkbox"/> AXIAL <input type="checkbox"/> CIRCUMFERENTIAL													
				WELDS OR PARTS EXAMINED																	
REVIEWED BY LEVEL III:				DATE:				REVIEWED BY:				DATE:									

966-16280

FIGURE 7

OCI 6-4
Rev. 4

ULT. * ONIC EXAMINATION DATA SHEET - NOZZLE INNER IIA. 5

REPORT NO.: EH-003

PROJECT: WXP-2		SYSTEM: Feed Water		DRAWING NO.: RPV - 101				
NOZZLE DESCRIPTION: N-4 Feed Water				NOZZLE NO.: N 4 - 150 - 1R				
MATERIAL TYPE: Carbon Steel				ZONE NO.: 1				
NO. OF SCAN DIRECTIONS: 2 each zone				DATE: 2/23/83				
INSTRUCTION NO.: OCI 6-4		REVISION: 0		TIME START: 0940				
EXAMINER: J Smith		LEVEL: II		TIME STOP: 1050				
EXAMINER: A Brown		LEVEL: III		PART TEMP: 65				
CAL STANDARD NO.: Shell Ring #3		THICKNESS: 6.6"		CAL SHEET NO.: JS-003				
ACCEPTANCE CRITERIA:				ANGLE: 70°				
INDICATION NUMBER	POLAR REFERENCE	AZIMUTH (COI)	D DISTANCE	AMPLITUDE (%FSI)	METAL PATH	SCAN (CW OR CCW)	ZONE NO.	COMMENTS
1	45	2.25	1.25	90	14.75	CW	1	
2	315	3.2	3.05	65	15.04	CCW	1	
3	300	2.6	2.2	70	17.8	CCW	1	
4	85	3.2	3.0	75	17.7	CW	1	
SAMPLE								
REVIEWED BY LEVEL III: L. Green				DATE: 2/23/83		REVIEWED BY:		DATE:

FIGURE 8

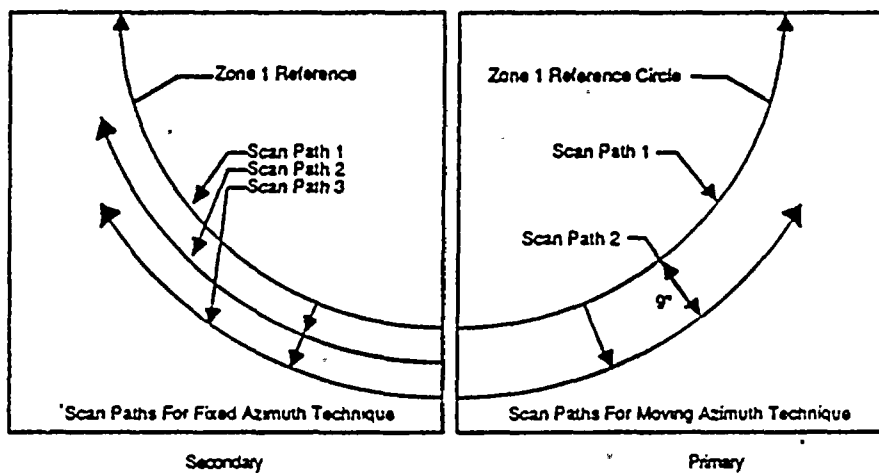
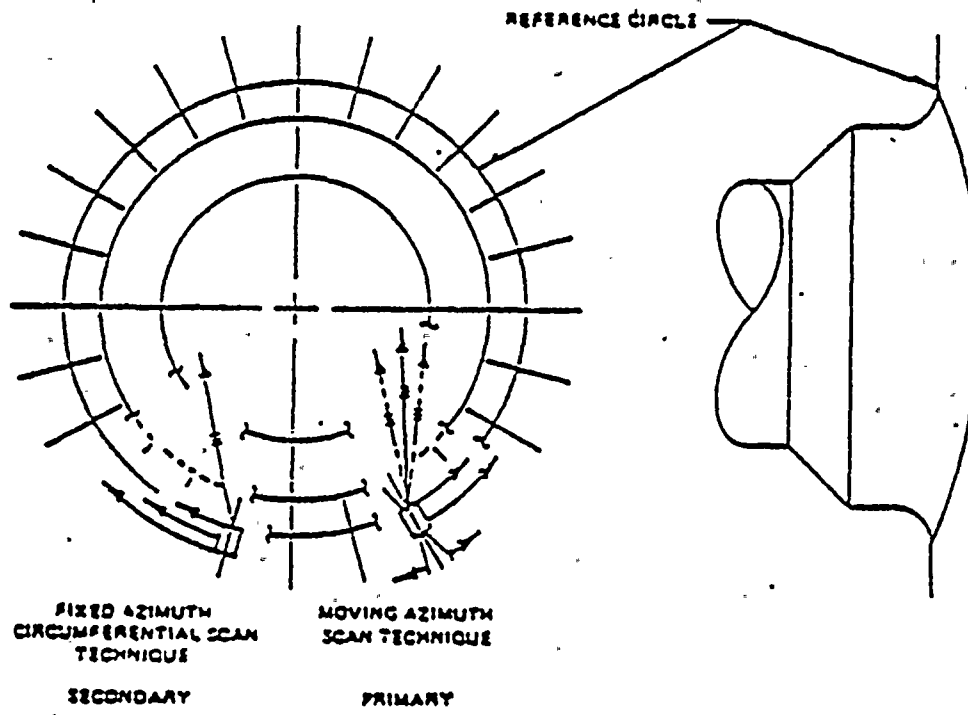

FIGURE 9 SCANNING MOTIONS FOR THE ZONE 1 EXAMINATION

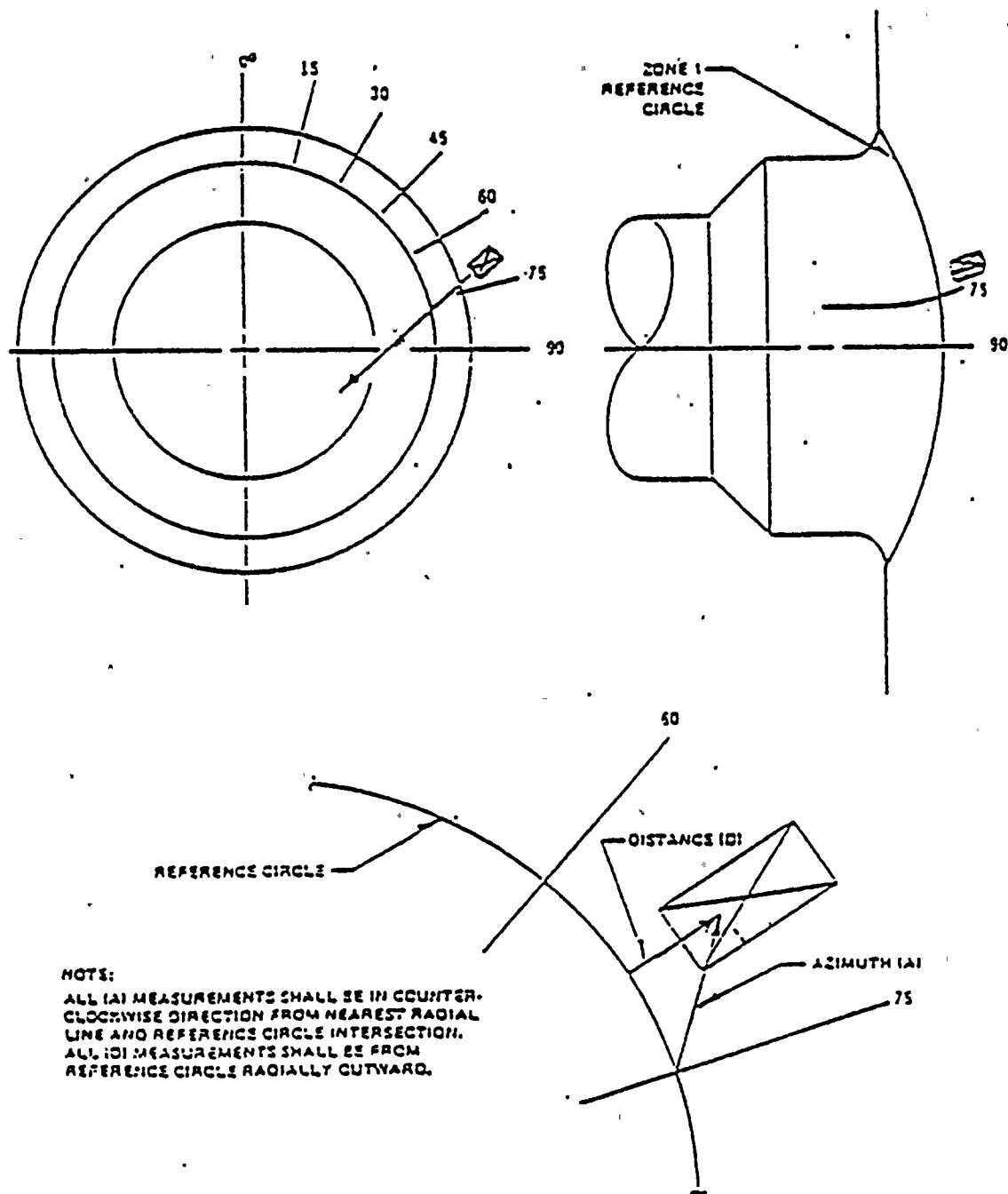

FIGURE 10 MEASUREMENT CRITERIA FOR RECORDING UT

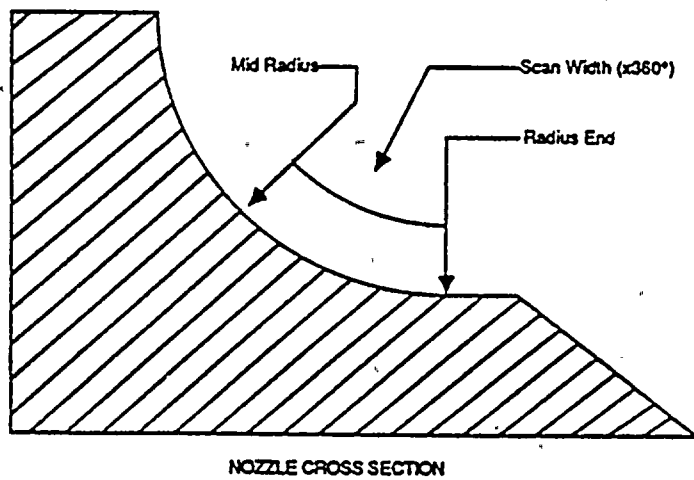
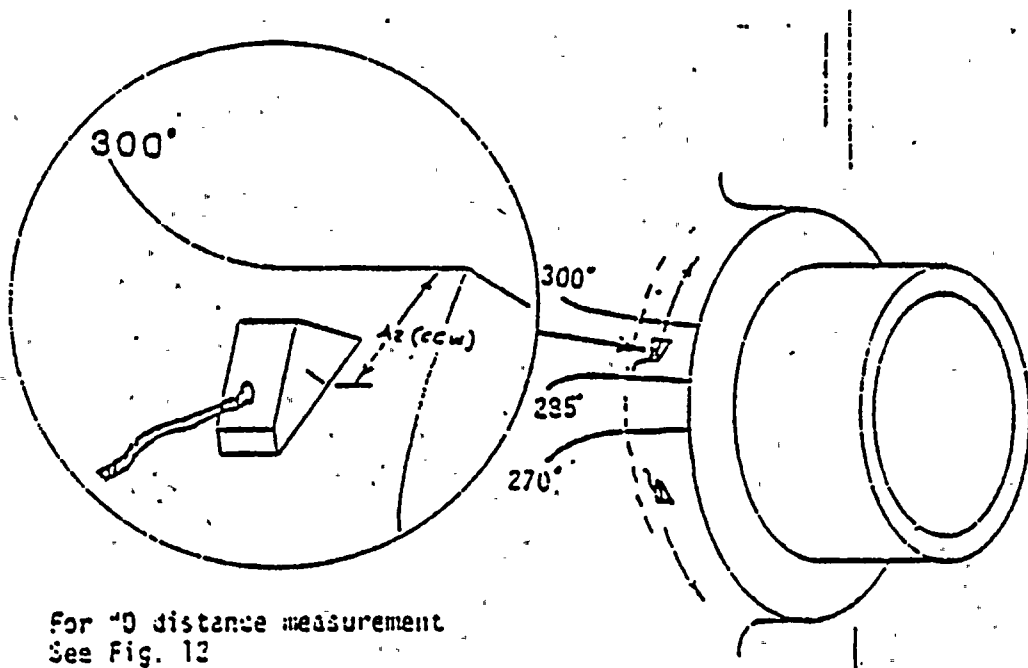
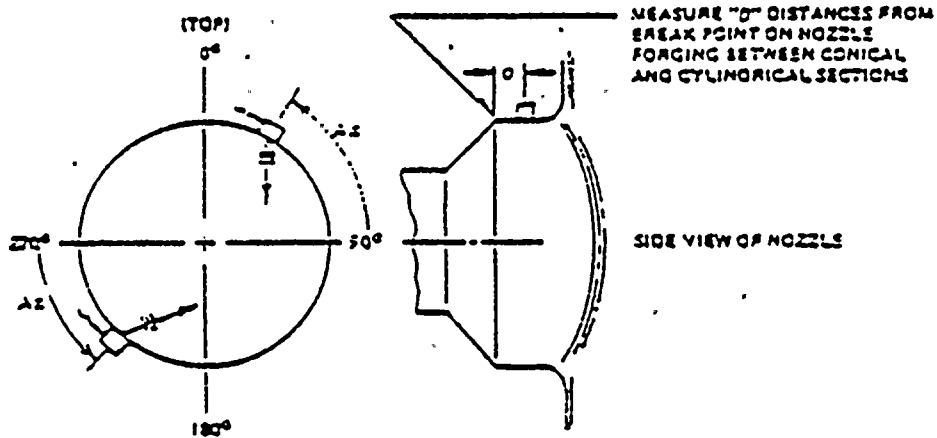
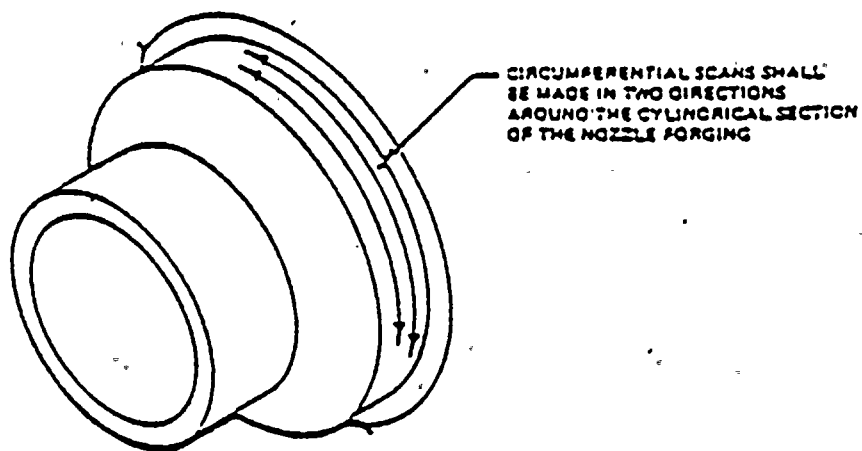
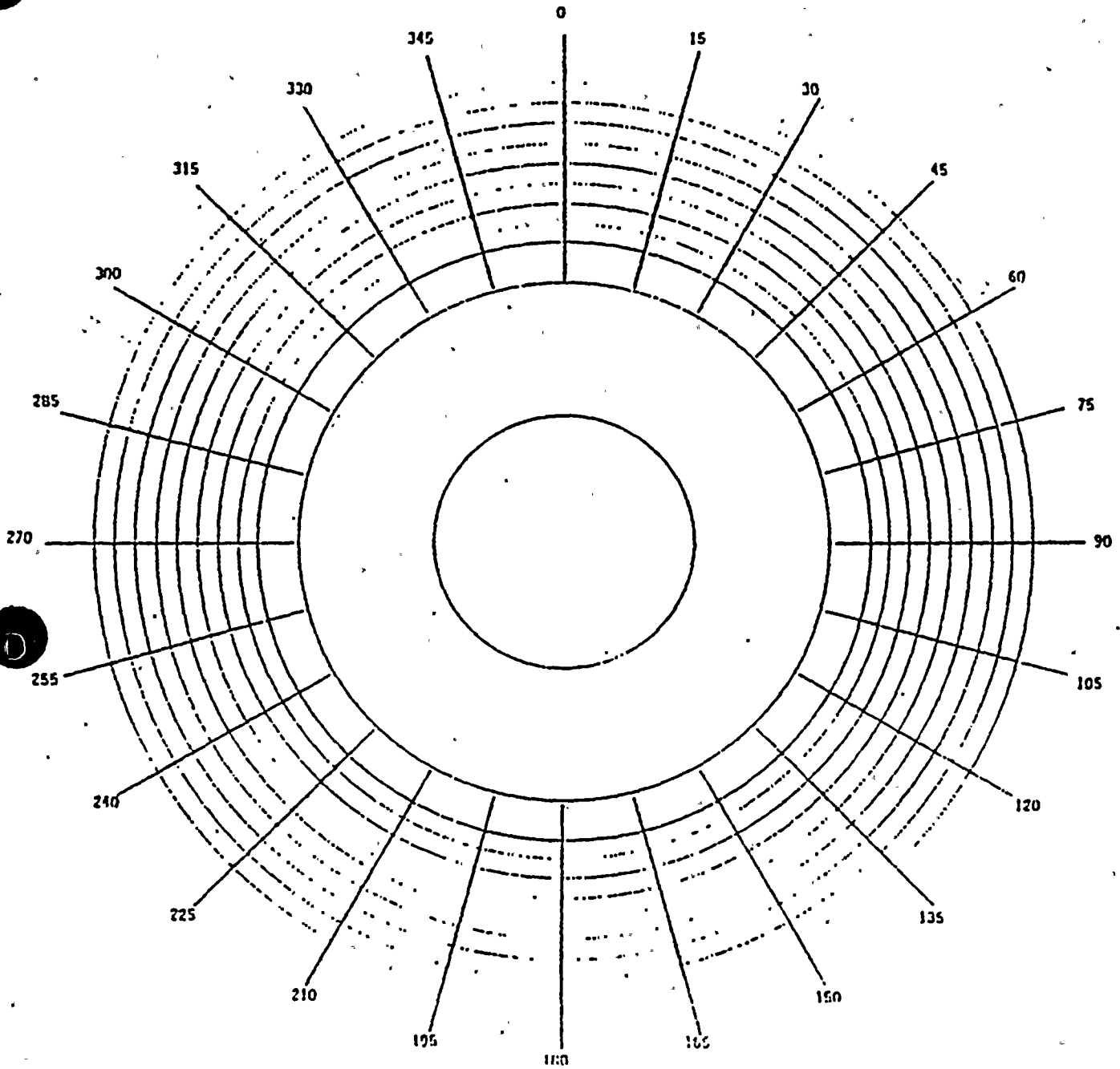

FIGURE 11 REQUIRED SCAN PATHS AND MEASUREMENT CRITERIA FOR ZONE 2 EXAMINTIONS



Reference Az lines are each 15° around the nozzle. All Az measurements are made in a counter-clockwise direction from these lines to the Index mark on the search unit. View made looking toward the vessel.

FIGURE 12. ZONE 3 SCANNING AND LOCATION REQUIREMENTS



Plot of Indication(s)
for nozzle No.: _____

Report No.: _____

Scale 1/2"

FIGURE 13



WASHINGTON PUBLIC POWER
SUPPLY SYSTEM

NDE & I INSTRUCTION

NO.	QCI 6-13
REV. NO.	4
EFFECTIVE DATE	4-10-87
QUALITY AFFECTING	<input checked="" type="checkbox"/> YES <input type="checkbox"/> NO

TITLE
ULTRASONIC EXAMINATION OF PIPING WELDS (MANUAL).

1.0 PURPOSE AND SCOPE

- 1.1 This instruction defines the method for manual contact ultrasonic examination of similar and dissimilar metal welds in piping systems 0.2 to 6.0 inches in thickness. The methods outlined in this instruction meet the requirements of the ASME Boiler and Pressure Vessel Code, Section XI, 1980 Edition through Winter 1980 Addenda and Appendix III.
- 1.2 These examinations may be performed by Supply System personnel or by a Supply System Contractor under Supply System supervision.

2.0 DEFINITIONS

None

3.0 PROCEDURE

3.1 Personnel Qualifications

- 3.1.1 Supply System personnel shall be certified in accordance with Reference 6.2.
- 3.1.2 Contractor personnel shall be certified to the contractor's Quality Assurance Program provided the program has been approved by the Supply System. As an alternative, the contractor personnel shall be certified in accordance with Reference 6.2.
- 3.1.3 Personnel designated as trainees may assist the Level II or III in performance of the examinations to this instruction.
- 3.1.4 Level I individuals shall perform only specific setups, calibrations, tests or record data to the requirements of this instruction and shall implement this instruction only with the direct participation of a Level II or higher individual. The Level I shall not independently evaluate or accept the results of the examinations performed to this instruction.
- 3.1.5 Examination teams shall include at least one Level II or Level III UT examiner.

WRITTEN BY <i>[Signature]</i>	CHECKED BY/DATE <i>[Signature]</i>	LEVEL/DATE <i>[Signature]</i>
DEPT. APPROVAL/DATE <i>[Signature]</i>	SUPERSEDES ISSUE Rev. 3	PAGE 19 OF

- 3.2 Ultrasonic Instruments - The pulse-echo, ultrasonic flaw detection instruments shall be equipped with a stepped gain control, graduated in units no larger than 2 dB. Instruments considered acceptable for examination are listed below; other instruments may be used if the model type is qualified.

Krautkramer USIP-11
Krautkramer USL-48
Nortec NDT-131 or 131D

3.3 Transducers

3.3.1 Straight Beam - Single or dual element ceramic type transducers having an area from 0.049 to 1.0 square inch shall be used. Base material examinations and thickness measurements will normally be conducted using a 2.25 or 5.0 MHz longitudinal wave transducer; however, other frequencies may be used where metallurgical characteristics prevent effective use of 2.25 or 5.0 MHz transducers.

3.3.2 Angle Beam - Single or dual element ceramic type transducers having an area from 0.049 to 1.0 square inch shall be used. The initial examination will normally be conducted using 2.25 MHz shear wave transducers with a beam angle of 43 to 47 degrees. Other angles and wave modes may be used for evaluation or indications and where wall thickness or geometric configuration impedes effective use of the 45 degree angle. The tolerance for other angles shall be +3 degrees. Transducers of other frequencies and wave modes may also be used for evaluation of indications or where metallurgical characteristics prevent effective use of 2.25 MHz shear wave transducers. The transducer exit point and beam angle shall be verified, prior to examination, using an IIW (International Institute of Welding) or Rompas calibration block.

3.4 Couplant - Ultragel II or an equivalent shall be used as the liquid couplant. Certification of acceptable sulfur and halogen content shall be obtained and made available for each lot or batch number.

- (a) Couplant shall be analyzed for sulfur content in accordance with ASTM D129-64. The sulfur content of the residue shall not exceed 1% by weight.
- (b) Couplants shall be analyzed for chloride content in accordance with ASTM D808-63. The chloride content of the residue shall not exceed 1% by weight.

- 3.5 Calibration Blocks - Calibration blocks shall be as specified in Section 14 of the Inservice Inspection Program Plan or as specified by the Responsible Technical Organization (RTO).
- 3.6 Surface Preparation - The finished contact surfaces shall be free from weld splatter or any roughness that would interfere with free movement of the search unit or coatings which would impair the transmission of ultrasonic vibrations.
- 3.7 Instrument Calibration - The ultrasonic instrument linearity shall be checked each day prior to its use and documented on the Calibration Data Sheet shown in Attachment 7.2. Linearity shall be determined in accordance with the requirements of Paragraphs (a) and (b) below:
- (a) Screen Height Linearity Check - To verify the ability of the ultrasonic instrument to meet screen height linearity requirements, position an angle beam search unit so that responses can be observed from any two reflectors in a calibration block. Adjust the search unit position to give a 2 to 1 ratio of amplitudes between the responses, with the larger set at 80% of full screen height (FSH). Without moving the search unit, adjust the gain control to successively set the larger signal from 100% to 20% FSH in 10% increments or in 2 dB increments if the instrument is equipped with a stepped gain control. The smaller signal amplitude must be 50% of the larger amplitude signal within 5% FSH. Instruments that do not meet this requirement shall not be used.
- (b) Amplitude Control Linearity Check - To verify the accuracy of the amplitude control in the ultrasonic instrument, position a search unit so that a response from a reflector in the calibration block is peaked on the screen. The signal amplitude shall be brought as near as possible to 80% FSH with the dB control. If necessary, the final adjustment to 80% FSH can be made with the variable gain control. Using only the dB control, the dB changes indicated below shall be made and the resulting amplitude compared with the allowable amplitude limits. The procedure shall be repeated for 40% and 20% FSH amplitudes. The initial settings and readings shall be estimated to the nearest 1% of full screen. Instruments that do not meet this requirement shall not be used.

<u>Initial Amplitude Set at % FSH</u>	<u>dB Control Change</u>	<u>Amplitude Limits in % FSH</u>
80	-6	32 to 48
80	-12	16 to 24
40	+6	64 to 96
20	+12	64 to 96

3.8. General Requirements for Examination Calibration

- 3.8.1 Calibration shall be performed from the surface of the calibration block which corresponds to the component surface to be examined.
- 3.8.2 The calibration block temperature shall be within 25°F of the component being examined.
- 3.8.3 Calibration shall include the complete ultrasonic examination system. Any change in couplants, cables, transducers, wedges, ultrasonic instruments, or any other parts of the examination system shall be cause for a calibration check.
- (a) At least every 4 hours during an examination;
 - (b) At the start and finish of each completed examination;
 - (c) At each change of examiners;
 - (d) In the event of loss of power; and
 - (e) If any part of the examination system has been changed, such as, search units, cables or ultrasonic instruments;
 - (f) If the operator suspects a malfunction.
- 3.8.5 Calibration checks may be performed on a secondary reference, such as an IIW, Rompas block or equivalent, provided the response from the block has been referenced after initial calibration. The tolerances of 3.8.7 and 3.8.8 shall apply for this operation.
- 3.8.6 Final calibration shall be performed on the calibration block used for initial calibration.
- 3.8.7 Recalibration (Sweep Only) - If the indication from any of the calibration reflectors has moved on the sweep line more than 10%, correct the sweep range calibration and note the correction on the Calibration Data Sheet. If



recordable indications were noted on the Examination Data Sheets, those data sheets shall be voided. A new calibration shall be made and recorded and the voided examination areas shall be reexamined.

3.8.8 Recalibration (Amplitude Only) - If the amplitude of any of the calibration reflectors has changed by more than 2 dB, all data sheets since the last acceptable calibration check shall be marked void. A new calibration shall be made and recorded and the voided examination areas reexamined.

3.8.9 All required calibration data shall be recorded on the Ultrasonic Calibration Data Sheet, Attachment 7.2.

3.9 Qualification - Prior to use of this instruction, the calibration techniques in 4.0 shall be demonstrated in the presence of an Authorized Nuclear Inspector. The successful completion of these calibrations shall be documented on Calibration Sheets, Attachment 7.2. These calibrations shall serve as a generic qualification for record purposes only as the instruction is essentially qualified upon each successful calibration used during the course of the weld examinations.

4.0 PROCEDURE

4.1 Angle Beam Calibration

4.1.1 Calibrate the instrument sweep to the required sound path distance using an IIW, Rompas or an equivalent block having known dimensions. The sweep calibration shall be sufficient to include all reflectors required to construct the distance-amplitude correction (DAC) curve.

4.1.2 For the examination of piping welds using the 1/2 "V" path technique, the calibration shall be performed in accordance with the following to detect reflectors parallel or transverse to the weld:

- (a) Position the search unit for maximum response from the side drilled hole (1/8, 2/8 or 3/8 node) which produces the highest amplitude signal. For this operation, the centerline of the search unit shall be at least 3/4" from the nearest side of the calibration block to avoid using the reflection from the hole and the side of the block. Adjust the instrument gain to set this signal at 80% of full screen height and mark the location and amplitude of the signal on the screen.

- (b) Without changing the instrument controls, maximize the signal of the two remaining holes and mark their amplitudes and locations on the screen.
- (c) As an alternate, if the calibration block is designed such that it only contains a 1/2 T side drilled hole, position the search unit for maximum response from this hole. Then adjust the instrument gain to set this signal at 80% of full screen height and mark the location and amplitude of the signal on the screen. Without changing the instrument controls, maximize the signal from this hole at the 6/8 node position and mark the amplitudes and locations on the screen.
- (d) Connect these points on the screen with a line and extrapolate the curve an additional 1/4 T to cover the full examination thickness. This completes the construction of the DAC curve only.
- (e) To determine the primary reference level, position the search unit to obtain the maximum response from the notch at the 1/2 "V" path location. Adjust the amplitude of the notch to be equal to the DAC curve. This is the primary DAC reference level.
- (f) Record and plot all calibration data on the appropriate areas of the Calibration Data Sheet.
- (g) After the primary DAC reference level has been established on the pipe calibration standard, a calibration reference response may be established on a Rompas or other standard reference block. The response shall include both sweep and amplitude calibration points and the gain setting used to establish them. This information shall be recorded on the appropriate area of the Calibration Data Sheet. This reference response may then be used to perform calibration checks. Final calibration, however, shall be performed on the pipe calibration standard.

4.1.3 For the examination of piping welds using the 1 "V" path or greater technique, the calibration shall be performed in accordance with the following to detect reflectors parallel or transverse to the weld:

- (a) Position the search unit for maximum response from the circumferential notch on the opposite side of the calibration block and adjust the instrument gain to set the response at 80% of full screen height. Mark the location and amplitude on the screen.



- (b) Without adjusting the gain, obtain responses from the notches at 1- and 1-1/2 or greater "V" path locations. Mark the locations and amplitudes on the screen.
- (c) Connect the points with a line. This is the primary DAC reference level.
- (d) Record and plot all calibration data on the appropriate areas of the Calibration Data Sheet as shown in Attachment 7.2.
- (e) After the primary DAC reference level has been established on the pipe calibration standard, a calibration reference response may be established on a Rompas or other standard reference block. The response shall include both sweep and amplitude calibration points and the gain setting used to establish them. This information shall be recorded on the appropriate area of the Calibration Data Sheet. This reference response may then be used to perform calibration checks. Final calibration, however, shall be performed on the pipe calibration standard.

4.2 Straight Beam Calibration - Preservice Inspection Only

- 4.2.1 Calibrate the instrument sweep to a distance sufficient to include the thickness of the material being examined using an IIW, Rompas or an equivalent block having known dimensions.
- 4.2.2 For the examination of piping, fabricated from plate material, for laminar reflectors, calibration shall be performed according to the following:
 - (a) Position the search unit on the part to be examined using sufficient gain to produce a back reflection from the part of at least 80% full screen height.
 - (b) Record and plot all calibration data on the appropriate areas of the Calibration Data Sheet.

4.3 Straight Beam Examination of Plate Material - Preservice Inspection Only

- 4.3.1 This examination shall be performed only on pipe and/or fittings fabricated from plate material.



- 4.3.2 For detection of laminar reflectors in plate material, the search unit shall be placed on the base material and manipulated to ensure coverage of the entire area through which the sound must pass during the angle beam examination.
- 4.3.3 The instrument gain shall be adjusted during the examination to maintain a back reflection of at least 50% full screen height while scanning.

4.4 Angle Beam Examination of Welds

- 4.4.1 For detection of reflectors parallel to the weld, the search unit shall be placed on the contact surface with the beam essentially perpendicular to the weld centerline. The search unit shall be manipulated to ensure the sound beam passes through the entire area of interest using the 1/2 or 1-1/2 or greater "Y" path examination technique from both sides of the weld. Physical or other limitations which prevent complete examination of the area of interest shall be documented on the Examination Data Sheet.
- 4.4.2 For detection of reflectors transverse to the weld, the search unit shall be placed on the weld with the beam directed along the weld in two opposite directions.
- 4.4.3 As an alternate, if the weld contour is such that the examination cannot be performed from the weld crown, the search unit shall be placed directly adjacent to the weld edge. The sound beam shall be directed parallel to the weld and the search unit manipulated laterally and longitudinally. Physical or other limitations which prevent complete examination of the weld area shall be documented on the Examination Data Sheet.
- 4.4.4 Welds that cannot be examined from at least one side using the angle beam technique shall be examined by another volumetric method.

4.5 Scanning Requirements for Angle Beam Examination

- 4.5.1 Area of Interest - The area of interest is the volume of material which is to be examined and shall include the inner 1/3 T of the weld and 1/4 inch of adjacent base material on both sides of the weld as measured from the weld crown edge.



4.5.2 The area of interest shall be examined from both sides, when possible, with the search unit directed normal to the weld for detection of reflectors parallel to the weld using the 1/2 or 1 or greater "V" path examination technique whichever is applicable.

4.5.3 For examination of reflectors transverse to the weld, the search unit shall be placed on the weld crown when possible, and directed parallel to the weld. Scanning shall be performed in both directions along the weld.

4.5.4 For longitudinal weld seams adjacent to circumferential welds the entire weld length shall be examined during preservice examination. For inservice examination, only the first 1 foot of the weld for Class 1 and 2-1/2 T for Class 2, need be examined. All other welds shall be examined for their full length.

4.5.5 The angle beam coverage for examination of reflectors parallel to the weld using the 1/2 "V" path examination technique shall be sufficient to permit the sound beam to cover the inner 1/3 T of the weld and at least 1/4 inch of the adjacent base material on both sides of the weld edge. Manipulation of the search unit over the weld crown may be required to achieve this coverage using the 1/2 "V" examination technique.

4.5.6 For the 1-1/2 "V" path technique, the minimum coverage shall be in accordance with the chart below and in all cases shall be sufficient to cover the lower 1/3 of the weld and 1/4 inch of the base material adjacent to the weld.

Beam Angle	Required Scan Distance Measured from the Weld Centerline - Pipe Thickness is "T"
------------	--

45	At least 3-1/2 T
----	------------------

60	At least 5 T
----	--------------

4.5.7 The manual scanning rate shall not exceed 6.0 inches per second. Each pass of the search unit shall overlap a minimum of 10% of the transducer piezoelectric element dimension perpendicular to the direction of scan.

4.6 Scanning Sensitivity - For angle beam examination, scanning shall be performed at a minimum of 2X (6 dB) above the primary reference level. Six dB increases the signal amplitude by a factor of approximately 2, making the primary reference curve a 50% DAC curve. Recording of indications requires the signal to be adjusted

to the point where it is equal to the DAC curve using the dB control. Signal amplitude can then be determined from the following chart using the observed change in the dB control.

<u>dB Gain - % DAC</u>	<u>dB Gain - % DAC</u>
0 - 100	0 - 100
-1 - 112	+1 - 90
-2 - 125	+2 - 80
-3 - 141	+3 - 70
-4 - 159	+4 - 63
-5 - 178	+5 - 56
-6 - 200	+6 - 50
-7 - 224	+7 - 45
-9 - 282	+8 - 36
-10 - 316	+9 - 32
-11 - 355	+10 - 28
-12 - 400	+12 - 25
-13 - 447	+13 - 22
-14 - 501	+14 - 20
-15 - 562	+15 - 18
-16 - 631	+16 - 16
-17 - 708	+17 - 14
-18 - 794	+18 - 13
-19 - 891	+19 - 11
-20 - 1000	+20 - 10

4.7 Weld Thickness Measurement - Thickness measurements may be taken at or near the 0 degree reference point and at 90 degree intervals around each weld on which a data plot is performed. The measurements will be made on:

- (a) The weld centerline;
- (b) In the heat affected zone as near as possible to each edge of the weld; and
- (c) On the base material on each side of the weld.

4.7.1 In addition, the location of the pipe counterbore transition should be determined when possible and the distance from the weld centerline documented on the Examination Data Sheet.

4.7.2 All measurements shall be documented on the appropriate area of the Examination Data Sheet shown in Attachment 7.1.



4.8 Data Recording for Straight Beam Examination - If the response from the laminar reflector exceeds the remaining back reflection response in an area exceeding $3/4"$ in its longest dimension, the following data shall be recorded on the Examination Data Sheet.

- (a) Indication Number - Assign a number, beginning with 1, to each individual indication which is recorded.
- (b) Location Interval - Record the search unit location interval with respect to the stamped degree location numbers on the weld.
- (c) Beam Angle - Record the search unit beam angle (0°).
- (d) Scan Surface - Record the surface (1 or 2) on which the search unit is being applied. See Attachment 7.3.
- (e) Sound Path - Record the sound path distance to the reflector.
- (f) Length - Record the major dimension of the reflector in the 100% DAC length column.
- (g) Prepare a sketch showing the area in which the reflector exceeds the remaining back reflection and attach it to the Examination Data Sheet.

4.9 Data Recording for Angle Beam Examination of Ferritic Steel Welds - If the maximum signal amplitude equals or exceeds 50% of the primary reference level, the following data shall be recorded on the Examination Data Sheet.

- (a) Indication Number - Assign a number beginning with 1 to each individual indication which is recorded on each weld.
- (b) Location Interval - Record the search unit location interval with respect to the stamped degree location numbers on the weld.
- (c) Beam Angle - Record the search unit beam angle, typically 45° or 60° .
- (d) Scan Surface - Record the surface (1 or 2) on which the search unit is being applied. See Attachment 7.3.
- (e) Beam Direction - Beam direction documents the search unit orientation with respect to the weld. Beam direction will be A, B, C or D. See Attachment 7.4.
- (f) Sound Path - Record the sound path distance to the indication at the peak amplitude location.

- (g) Extent - This information, recorded in degrees, is used to describe the extent of intermittent or continuous geometric indications. If a more thorough description is required, this blank may be used to reference the notes section.
- (h) Dampable - If an indication is dampable on the surface of the part, it should be stated in this column.
- (i) Amplitude - Record the maximum amplitude of the signal as a percentage of the primary reference level.
- (j) Length - Record the 50% to 50% and 100% to 100% DAC length of each indication.
- (k) Search Unit Position - Record, in inches, the distance (L) from the search unit to the smaller stamped location number and the distance from the exit point to the weld centerline (W) for longitudinally oriented indications or the distance from the search unit centerline to the weld centerline (W) for transversely oriented indications. These measurements shall be taken at the maximum amplitude location. See Attachment 7.5.
- (l) Through Wall Dimension - If the maximum signal amplitude equals or exceeds 100% DAC, record the minimum and maximum sound path distance and search unit location as the search unit is moved toward and away from the reflector. These measurements shall be taken at the 100% DAC level. The minimum and maximum sound path readings may not necessarily be at the point of maximum signal amplitude, nor do they have to be on the same scan line. Each indication shall be fully investigated to determine the points at which the minimum and maximum readings occur.

4.10 Data Recording for Angle Beam Examination of Austenitic and Dissimilar Metal Welds - Any crack-like indication, regardless of amplitude, shall be recorded and investigated to determine its shape, identity and location.

All indications 50% DAC or greater determined to be geometrical or metallurgical in origin shall be recorded.

Any other indications determined not to be geometrical or metallurgical in origin shall be recorded if they are 20% of the distance amplitude correction (DAC) curve or greater.

- (a) Indication Number - Assign a number, beginning with 1, to each individual indication which is recorded.
- (b) Location Interval - Record the search unit location interval with respect to the stamped degree location numbers on the weld.



- (c) Beam Angle - Record the search unit beam angle (0°).
- (d) Scan Surface - Record the surface (1 or 2) on which the search unit is being applied. See Attachment 7.3.
- (e) Beam Direction - Beam direction documents the search unit orientation with respect to the weld. Beam direction will be A, B, C or D. See Attachment 7.4.
- (e) Sound Path - Record the sound path distance to the reflector.
- (g) Extent - This information, recorded in degrees, is used to describe the extent of intermittent or continuous geometric indications. If a more thorough description is required, this blank may be used to reference the notes section.
- (h) Dampable - If an indication is dampable on the surface of the part, it should be stated in this column.
- (i) Amplitude - Record the maximum amplitude of the signal as a percentage of the primary reference level.
- (j) Length - Record the 20% to 20% (when required), 50% to 50% and 100% to 100% DAC length of each indication.
- (k) Search Unit Position - Record, in inches, the distance (L) from the search unit to the smaller stamped location number and the distance from the exit point to the weld centerline (W) for longitudinally oriented indications or the distance from the search unit centerline to the weld centerline (W) for transversely oriented indications. These measurements shall be taken at the maximum amplitude location. See Attachment 7.5.
- (l) Through Wall Dimension - If the maximum signal amplitude equals or exceeds 100% DAC, record the minimum and maximum sound path distance and search unit location as the search unit is moved toward and away from the reflector. These measurements shall be taken at the 100% DAC level. The minimum and maximum sound path readings may not necessarily be at the point of maximum signal amplitude, nor do they have to be on the same scan line. Each indication shall be fully investigated to determine the points at which the minimum and maximum readings occur.

4.11 Examination Records

- 4.11.1 A Calibration Data Sheet (Attachment 7.2) shall be prepared for each calibration.

- 4.11.2 An Examination Data Sheet shall be prepared for each weld examined and shall be related, by number, to a Calibration Data Sheet.

5.0 EVALUATION

- 5.1 All indications detected in the area of interest which produce signal amplitudes greater than 100% of the DAC reference level shall be individually reported and an evaluation made in accordance with Paragraph IWB-3514 of ASME Section XI, 1980 Edition Winter 1980 Addenda (Reference 6.1.1).
- 5.2 Any area where complete examination cannot be performed due to obstructions, configuration of weld, etc., shall be recorded and reported.
- 5.3 All data shall be submitted to the Supply System UT Level III for review. The Level III shall evaluate the examination data and indicate the status of the indication in the Evaluation column of the Ultrasonic Examination Data Sheet. The Level III shall also complete the Data Evaluation Form in accordance with NDE&I Instruction 12-8.

6.0 REFERENCES

- 6.1 American Society of Mechanical Engineers Boiler and Pressure Vessel Code, 1980 Edition through Winter 1980 Addenda.
- 6.1.1 Section XI - "Rules for Inservice Inspection of Nuclear Power Plant Components".
- 6.2 The Supply System "Program Manual for Qualification and Certification of Examination, Testing and Inspection Personnel WMC-034".

7.0 ATTACHMENTS

- 7.1 Examination Data Sheet
- 7.2 Calibration Data Sheet
- 7.3 Examination Surfaces
- 7.4 Beam Directions
- 7.5 Search Unit Location and Orientation

WASHINGTON PUBLIC POWER SUPPLY SYSTEM

ULTRASONIC EXAMINATION DATA SHEET

REPORT NO.: RCU-001

PROJECT: WHP-3		SYSTEM: RC		DRAWING NO.: RC-101-1	
WELD/PART DESCRIPTION: Pipe to elbow		WELD/PART NO.: RC-42-501-3			
MATERIAL TYPE: CS		CAL STANDARD NO.: UT-126		THICKNESS: 3.6	
NO. OF SCAN DIRECTIONS: 4		LIMITED EXAM: <input checked="" type="checkbox"/> NO <input type="checkbox"/> YES		ACCEPTANCE CRITERIA: IWB-3514	
INSTRUCTION NO.: 6-20		REVISION: 0		ANGLE: 0	
EXAMINER: T. Smith		LEVEL: II		DATE: 12-28-82	
EXAMINER: B. Jones		LEVEL: I		DATE: 1-1-83	
		TIME START: 8:40 am		TIME START: 9:00 am	
		TIME STOP: 9:50 am		TIME STOP: 10:00 am	
		PART TEMP: 72 °F		PART TEMP: 72 °F	
		CAL SHEET NO.: TS-001		CAL SHEET NO.: TS-002	
		CHART NO.: N/A		CHART NO.: RCU-001	
		CHART NO.:		CHART NO.:	

THICKNESS MEASUREMENTS							
WELD HEIGHT <u>Flush</u> SURFACE ONE				WELD WIDTH <u>2.2"</u> SURFACE TWO			
RM	COUNTER BORE	HAZ	WELD S	HAZ	COUNTER BORE	RM	
0°	3.6	N/A	3.6	3.6	3.6	N/A	3.7
90°	3.7	N/A	3.6	3.7	3.5	N/A	3.6
180°	3.6	N/A	3.5	3.6	3.6	N/A	3.5
270°	3.6	N/A	3.6	3.6	3.7	N/A	3.7

INDICATION NUMBER	LOCATION INTERVAL A-B OR PART NO	BEAM ANGLE / SCAN SURFACE	BEAM DIRECTION	SOUND PATH	EXTENT	DAMPABLE	MAX AMP	100 TO 100			50 TO 50			20 TO 20			EVALUATION				
								LENGTH	L	W	SP	D	SP	D	SP	D		ACCEPT	REJECT		
		0	NO	RECORDABLE	INDICATIONS																
1	0-90	45	1	B	4.7	N/A	No	160	.2	.4	N/A	5.4"	3.3"	4.9	3.45	4.5	3.2	.4	.283	X	
2	90-180	45	1	B	4.4	N/A	No	80	N/A	.3	N/A	7.7"	3.1"								X
3	180-270	45	2	A	4.25	N/A	No	63	N/A	.3	N/A	8.4"	3.0"								X
4	270-0	45	2	A	4.1	N/A	No	50	N/A	.1	N/A	2.3"	2.9"								X

REVIEWED BY LEVEL III: A. Brown	DATE: 1-2-83	REVIEWED BY: L. Green	DATE: 1-3-83
---------------------------------	--------------	-----------------------	--------------

SAMPLE

Examination Data Sheet

ATTACHMENT 7.1

WASHINGTON PUBLIC POWER SUPPLY SYSTEM

ULTRASONIC CALIBRATION SHEET

PROJECT: HNP-3				SYSTEM: RC				SHEET NO.: TS-002					
EXAMINER: T. Smith				LEVEL: II				DATE: 1-1-83					
EXAMINER: B. Jones				LEVEL: I				INSTRUCTION NO.: 6-20					
EXAMINER: B. Jones				LEVEL: I				REVISION: 0					
CALIBRATION STANDARD				CALIBRATION STANDARD SIMULATOR				TRANSDUCER					
SERIAL NUMBER UT-126				S/N 327 TEMP 72 °F				S/N 38417 WAVE MODE shear					
THICKNESS 3.6"				AMP 60 SWEEP 2.2 IN.				LENGTH 10ft					
TEMPERATURE 72 °F				GAIN IN dB 47				ACTUAL ANGLE 45°					
CABLE TYPE RG62/U				COUPLANT Ultragel II				BATCH NO. 3874					
CHART RECORDER TYPE: Gould Brush 220				S/N: 29184				UT INSTRUMENT TYPE: Nortec 131D					
S/N: 34643				INSTRUMENT CALIBRATION				PREVIOUSLY PERFORMED ON CALIBRATION SHEET NUMBER N/A					
SCREEN HEIGHT LINEARITY FOR CONTINUOUS GAIN CONTROL				SCREEN HEIGHT LINEARITY FOR 2dB STEP GAIN CONTROL				AMPLITUDE CONTROL LINEARITY					
HIGH 100 90 80 70 60 50 40 30 20				HIGH 100 80 63 50 40 32 25 20 16				AMPLITUDE % 80 80 40 20					
LOW 80 45 40 34 29 25 20 15 10				LOW 50 40 31 25 20 15 12 10 8				READING % 40 21 80 82					
								LIMITS % 32-48 18-24 64-96 64-96					
INITIAL CAL TIME: 8:40 am				SYSTEM CALIBRATION				FINAL CAL TIME: 3:10 pm					
INSTRUMENT SETTINGS		REFLECTORS		AMPLITUDE %FSH		SWEEP READING IN INCHES		SCREEN DAC PRESENTATION				CAL CHECKS	
COARSE RANGE - 10		1 /B NODE		80		.9		<p>SCREEN DAC PRESENTATION</p> <p>FULL SCREEN SWEEP 5 IN.</p>				11:40 T.S.	
COARSE DELAY - 1		2 /B NODE		60		1.8						2:40 T.S.	
RANGE CALIB - 547		3 /B NODE		40		2.7							
DELAY CALIB - 342		4 /B NODE		25		3.6							
FREQUENCY - 2.25		/B NODE											
GAIN IN dB - 44		/B NODE											
DAMPING - off		/B NODE											
REJECT - off		/B NODE											
FILTER - +		SEARCH UNIT ORIENTATION		AXIAL									
				CIRCUMFERENTIAL									
		WELDS OR PARTS EXAMINED											
		RC-42-501-3											
		RC-42-501-4											
		RC-42-501-5											
		RC-42-501-6											
REVIEWED BY LEVEL III: A. Brown				DATE: 1-2-83				REVIEWED BY: L. Green					
								DATE: 1-3-83					

Calibration Data Sheet

ATTACHMENT 7.2

QCI 6-13
Rev. 4

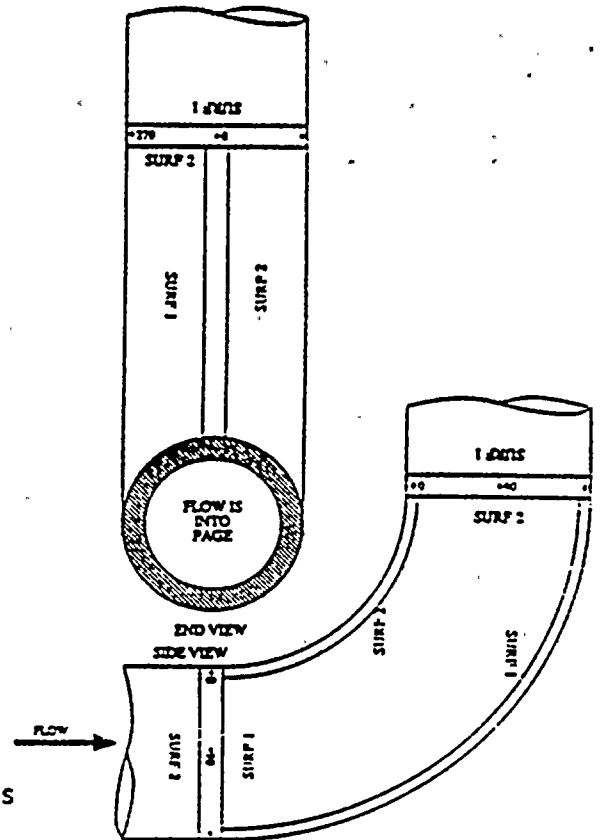
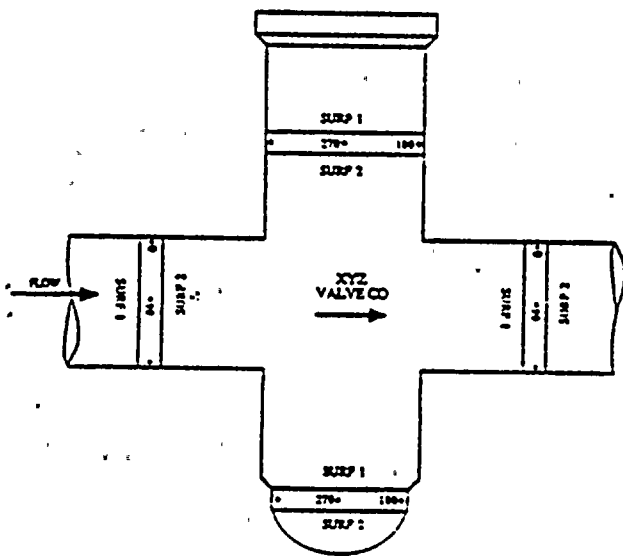
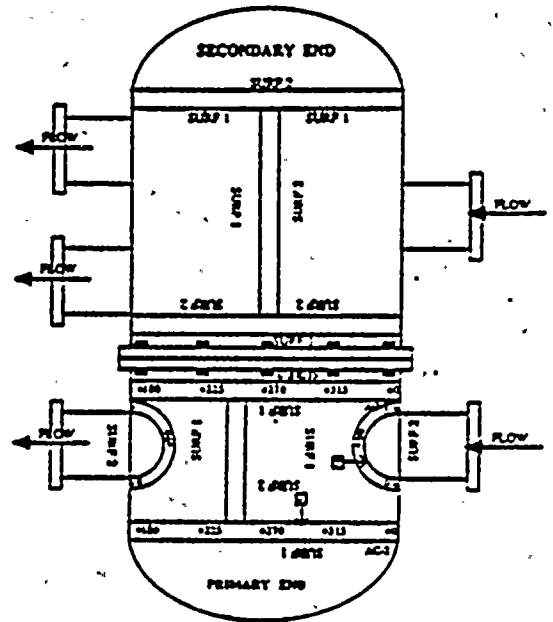
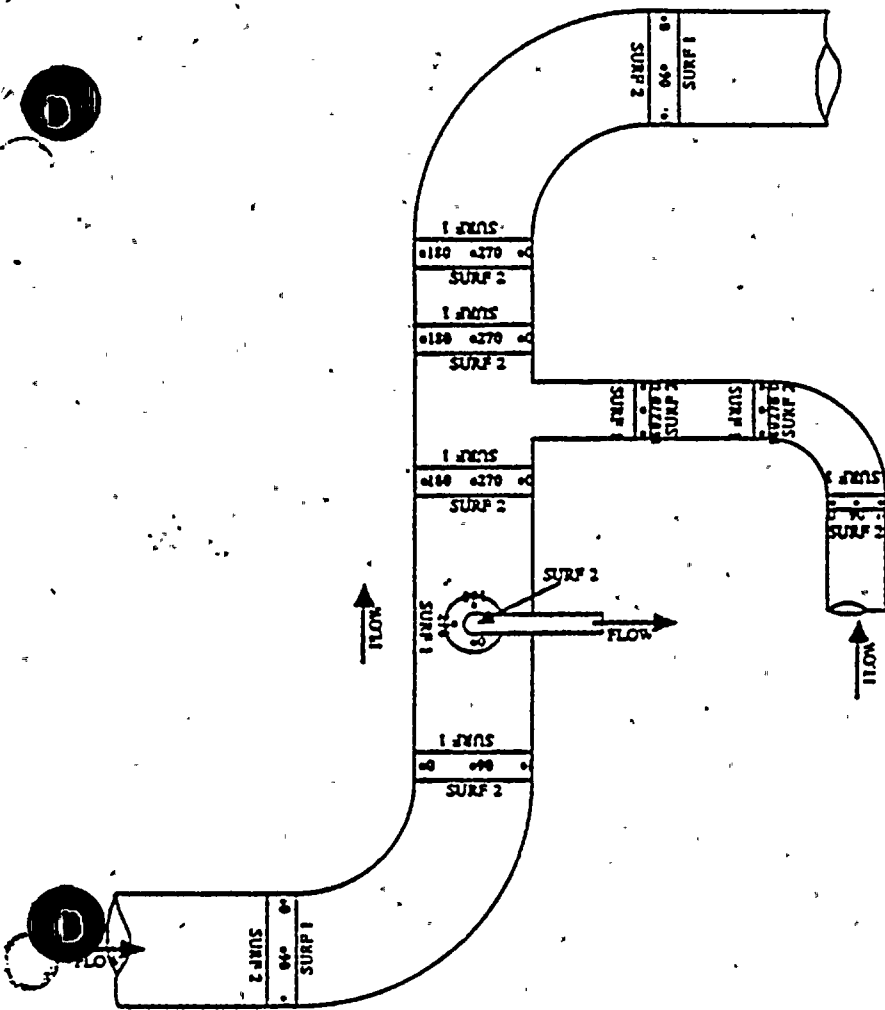

Examination Surfaces

ATTACHMENT 7.3

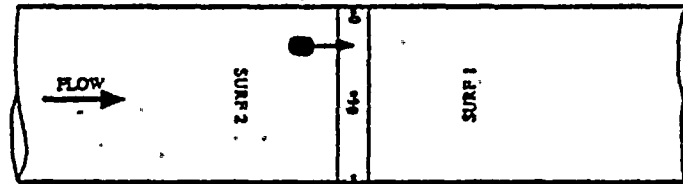

BEAM DIRECTION A
TRANSDUCER POINTING TOWARD SURFACE #1

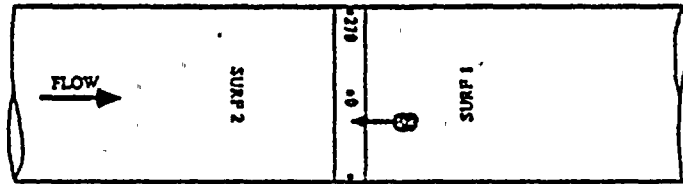

BEAM DIRECTION B
TRANSDUCER POINTING TOWARD SURFACE #2

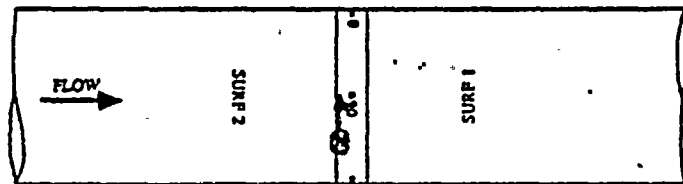

BEAM DIRECTION C
TRANSDUCER POINTING TOWARD PROGRESSIVELY SMALLER LOCATION MARKERS

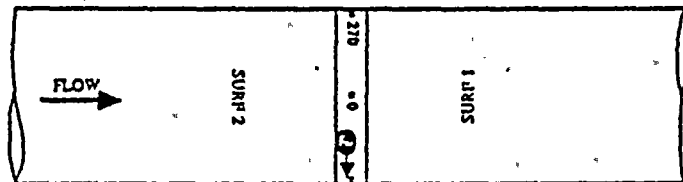

BEAM DIRECTION D
TRANSDUCER POINTING TOWARD PROGRESSIVELY LARGER LOCATION MARKERS

INDICATION NUMBER	LOCATION INTERVAL A - B OR PART NO.	BEAM ANGLE β	SCAN SURFACE	BEAM DIRECTION
	A - B			
1	0-90		2	A
2	0-90		1	B
3	0-90		2	C
4	0-90		2	D

Beam Directions

ATTACHMENT 7.4



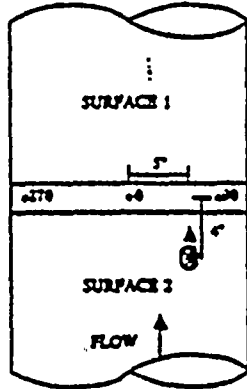

INDICATION #1

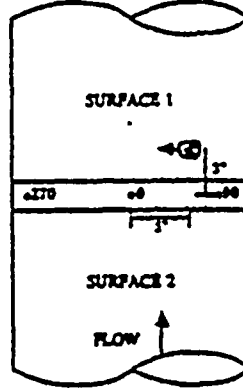

INDICATION #3

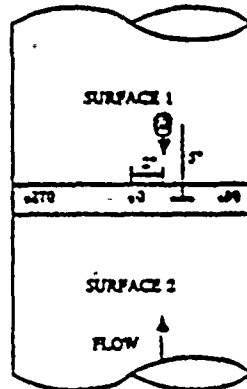

INDICATION #2

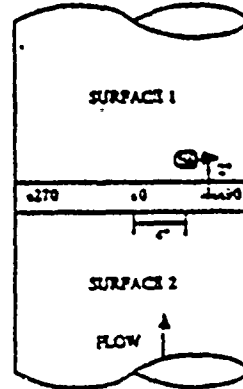

INDICATION #4

INDICATION NUMBER	LOCATION INTERVAL A-B OR PART NO. A-B	BEAM ANGLE θ	SCAN SURFACE	BEAM DIRECTION	SOUND PATH	EXTENT	DAMPABLE	MAX AMP TO AC	100 TO 20			SEARCH UNIT POSITION AT MAXIMUM AMP		THROUGH WALL DATA				Δ θ	Δ SP COS θ	EVALUATION	
									100 TO 100	20 TO 20	20 TO 20	L	W	MAXIMUM		MINIMUM				ACCEPT	REJECT
									LENGTH			SP	D	SP	D						
1	0-90	45°	2	A	3.7				5.0	4.0	2.0	4.2	2.5	3.9							
2	0-90	45°	1	B	3.7				2.0	5.0	1.0	4.2	1.5	4.2							
3	0-90	45°	1	C	3.7				5.0	1.0	1.0	5.2	1.5	4.2							
4	0-90	45°	1	D	3.7				4.0	2.0	1.0	3.2	1.5	4.2							

Search Unit Location and Orientation
ATTACHMENT 7.5



APPENDIX II

Drawing UTCB-250, Sheet 2 of 2, Revision 0
"WNP-2 FW Nozzle Mock-up UT-122"

Drawing UTCB-208, Revision 1, "U_i Calibration
Block, UT-120 RPV #2 and #3 Shell Rings"



THIS DRAWING IS INTENDED FOR THE PRESENT SERVICE AND HAS BEEN CHECKED FOR CONFORMANCE WITH THE PROVISIONS OF THE NORTH CAROLINA ENGINEERING ACT.

PROJECT NO. 10000

DATE 8-21-51

WVLE & CIV. ENGRS. 1100 W. MARKET ST. CHARLOTTE, N.C. 28202

WASHINGTON PUBLIC POWER SUPPLY SYSTEM

NO. 0118

REVISED FOR CONSTRUCTION

DATE 8-21-51

WVLE & CIV. ENGRS. 1100 W. MARKET ST. CHARLOTTE, N.C. 28202

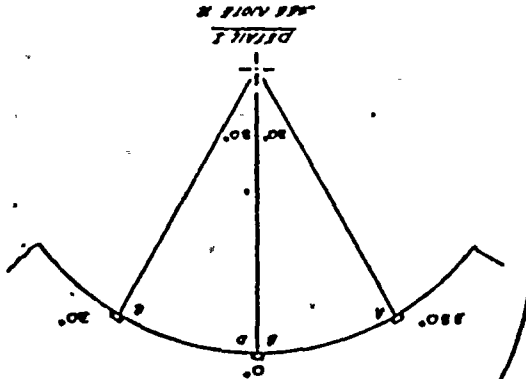

NOTCH	WIDTH	DEPTH	RADIUS
A	1/2" MAX	.800 ± .010	1"
B	1/2" MAX	.160 ± .010	1"
C	1/4" MAX	.110 ± .010	1"
D	1/4" MAX	.110 ± .010	1"
E	1/2" MAX	.160 ± .010	1"

REFERENCE:
 1. 72-2687 EXT. 51, 52
 2. (VPP-2515-694)
 3. (VPP-2515-712)

REVISIONS:
 1. 72-2687 EXT. 51, 52
 2. (VPP-2515-694)
 3. (VPP-2515-712)

NOTES:
 1. NOTCHES TO BE CUT WITH 4 MAX. NOMINAL 1/2" DIA. 3" DIA. DRILL. WIDTH OF NOTCH SHALL BE THAT OBTAINED BY MOVING WHEEL INTO METAL IN ONE PASS. NOMINAL 1/2" DIA. TO BE MAINTAINED. RADIUS OF 1/2" SHALL BE MAINTAINED. SMALLER THAN 1/2".
 2. NOTCHES SHALL BE LOCATED AS SHOWN IN DETAIL 1 WHEN VIEWING NOZZLE FROM THE VESSEL INTERIOR.
 3. NOTCH LOCATION SHALL BE 1/2" FROM THE VESSEL INTERIOR.
 4. NOTCHES SHALL BE 90° TO THE BONES.
 5. NAME PLATE (ATTACHED TO 0.01) W/ 2" FEEDWATER NOZZLE MARKUP UT-122.
 6. NAME PLATE (ATTACHED TO 0.01) W/ 2" FEEDWATER NOZZLE MARKUP UT-122.
 7. NAME PLATE (ATTACHED TO 0.01) W/ 2" FEEDWATER NOZZLE MARKUP UT-122.

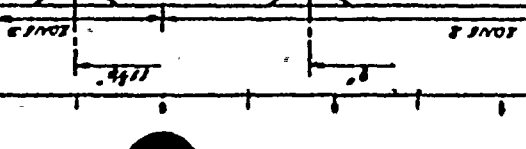
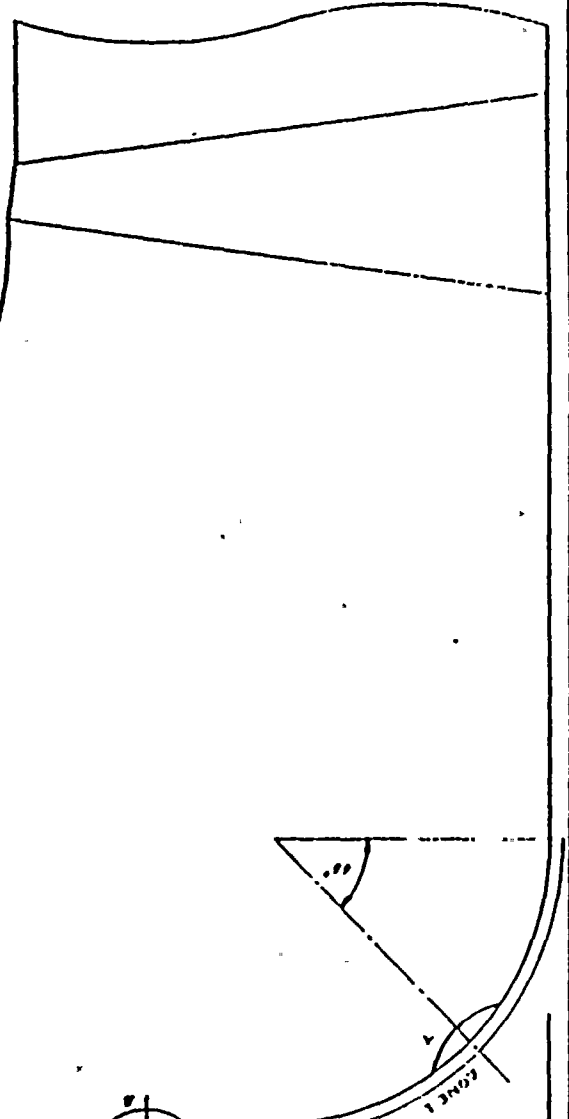

NOTES:
 1. NOTCHES TO BE CUT WITH 4 MAX. NOMINAL 1/2" DIA. 3" DIA. DRILL. WIDTH OF NOTCH SHALL BE THAT OBTAINED BY MOVING WHEEL INTO METAL IN ONE PASS. NOMINAL 1/2" DIA. TO BE MAINTAINED. RADIUS OF 1/2" SHALL BE MAINTAINED. SMALLER THAN 1/2".
 2. NOTCHES SHALL BE LOCATED AS SHOWN IN DETAIL 1 WHEN VIEWING NOZZLE FROM THE VESSEL INTERIOR.
 3. NOTCH LOCATION SHALL BE 1/2" FROM THE VESSEL INTERIOR.
 4. NOTCHES SHALL BE 90° TO THE BONES.
 5. NAME PLATE (ATTACHED TO 0.01) W/ 2" FEEDWATER NOZZLE MARKUP UT-122.
 6. NAME PLATE (ATTACHED TO 0.01) W/ 2" FEEDWATER NOZZLE MARKUP UT-122.
 7. NAME PLATE (ATTACHED TO 0.01) W/ 2" FEEDWATER NOZZLE MARKUP UT-122.

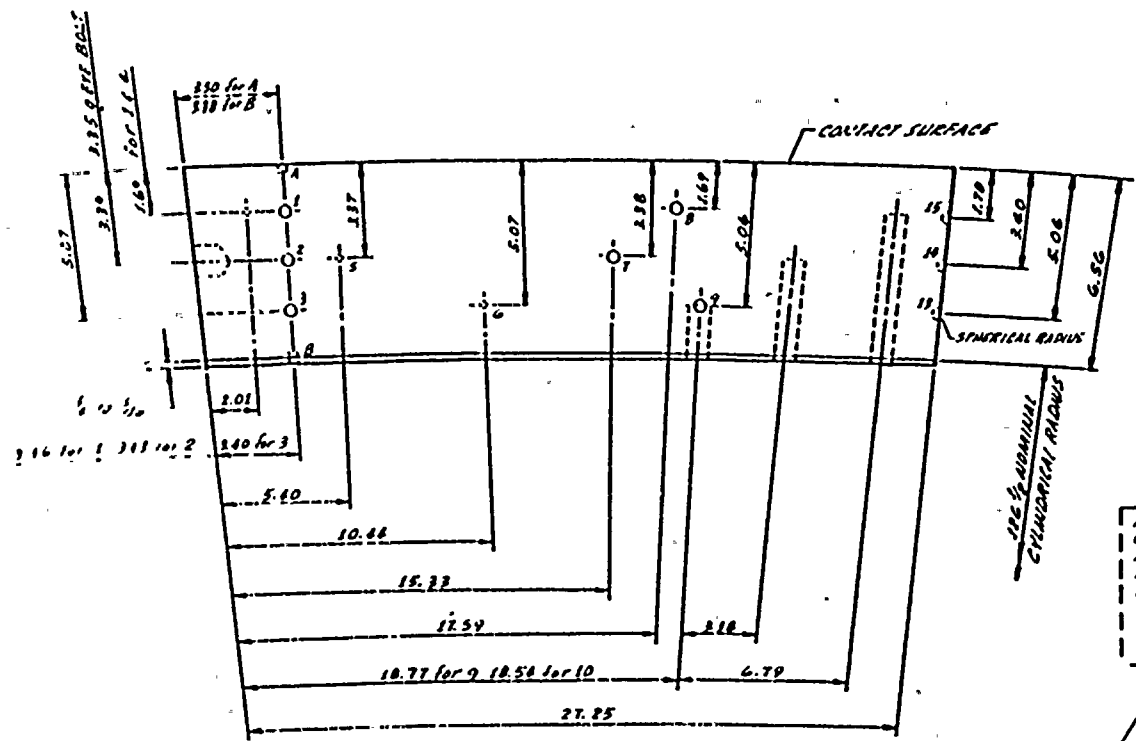

HOLES	Ø	DEPTH
1	.313	2.00
2	.913	2.02
3	.313	2.02
4	.170	2.00
5	.179	2.01
6	.179	2.01
7	.313	2.03
8	.313	2.03
9	.316	2.01
10	.76	1.82
11	.76	3.47
12	.76	5.17
13	.319	—
14	.319	—
15	.319	—

NOTICES	A	B
LENGTH	2.00	2.00
WIDTH	.121	.128
DEPTH	.130	.015

MADE FROM: #8 SHELL RING
 CONTACT NO: 78-2687
 MATERIAL SPEC: SA 533 GR B CL 1
 NICK N°: C 1500-S
 BASE METAL THK: 6 3/16
 1/8" = 1.69, 1/2" = 2.38 3/4" = 5.06
 WMP-P UT-120

- NOTES:**
1. AS DESIGNED & COIN FABRICATED CURVED CALIBRATION BLOCK. (SEE REF. DWG. FOR FABRICATION NOTES, REQUIREMENTS, PIECE NO & CUTTING SKETCH.)
 2. THE 3/8" (10) FLAT BOTTOM HOLE IS CLOSER TO THE CONTACT SURFACE THAN 1/4" C. USE AS BUILT DIA.
 3. ALL DIMENSIONS ARE IN INCHES.

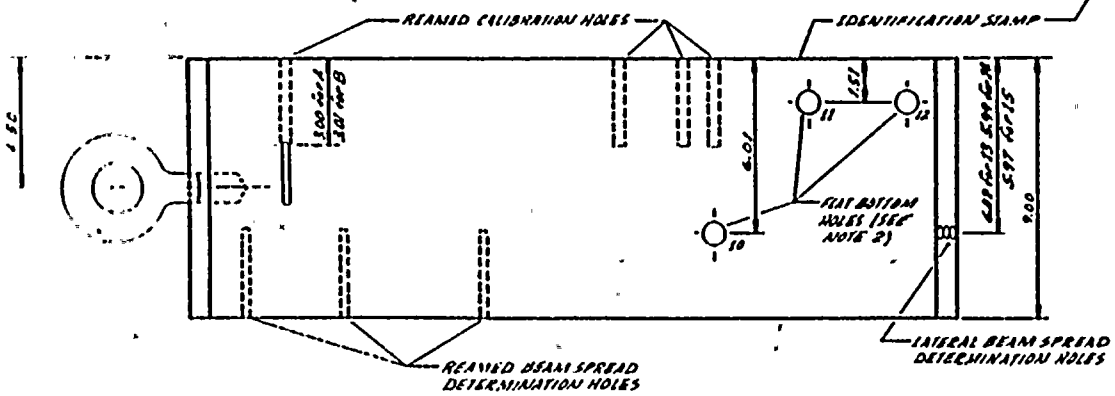

REFERENCE
 CBI NUCLEAR CO.
 205 AF 023 SH 120 REV 3

THIS DRAWING IS INTENDED FOR USE IN PRE-REVIEW AND INSERVICE INSPECTION PROGRAMS ONLY

 WASHINGTON PUBLIC POWER SUPPLY SYSTEM <small>RICHLAND, WASHINGTON 98541</small> WMP - 2	UT CALIBRATION BLOCK, UT 120 REV 02 & #8 SHELL RING
	DWG NO UTCB-208

NO	DATE	REVISION	BY	CHKD	APPRD	NO	DATE	REVISION	BY	CHKD	APPRD	DATE
						1	1-15-80	AS BUILT	REDA	RE	APPRD	1-15-80

