

REGULATORY INFORMATION DISTRIBUTION SYSTEM (RIDS)

ACCESSION NBR: 8405310177      DOC. DATE: 84/05/31      NOTARIZED: NO      DOCKET #  
 FACIL: 50-397 WPPSS Nuclear Project, Unit 2, Washington Public Powe      05000397  
 AUTH. NAME      AUTHOR AFFILIATION  
 SORENSEN, G.C.      Washington Public Power Supply System  
 RECIP. NAME      RECIPIENT AFFILIATION

SCHWENCER, A.      Licensing Branch 2

SUBJECT: "Reactor Containment Bldg Integrated Leak Rate Test." W/ 566 rot  
 840522 ltr.

DISTRIBUTION CODE: A017S      COPIES RECEIVED: LTR 1 ENCL 60 SIZE: 90  
 TITLE: OR Submittal: Append J Containment Leak Rate Testing

NOTES:

	RECIPIENT		COPIES		RECIPIENT		COPIES	
	ID	CODE/NAME	LTR	ENCL	ID	CODE/NAME	LTR	ENCL
	NRR	LB2 BC	01	7	7			
INTERNAL:	ELD/HDS2		13	1	1	NRR/DSI/CSB	09	1
	REG FILE		04	1	1	RGNS		1
EXTERNAL:	ACRS		11	10	10	LPDR	03	1
	NRC PDR		02	1	1	NSIC	05	1
	NTIS			1	1			

100

100

1

The following information was obtained from the records of the  
 Department of the Interior, Bureau of Land Management, on  
 the subject of the above-captioned matter.  
 On or about the date of the filing of the application for  
 the above-captioned matter, the Bureau of Land Management  
 advised that the same was being processed in accordance  
 with the provisions of the applicable laws and regulations.  
 The Bureau of Land Management is currently processing the  
 application in accordance with the provisions of the  
 applicable laws and regulations.

## Washington Public Power Supply System

P.O. Box 968 3000 George Washington Way Richland, Washington 99352 (509) 372-5000

May 22, 1984  
G02-84-338

Docket No. 50-397

Director of Nuclear Reactor Regulation  
Attention: Mr. A. Schwencer, Chief  
Licensing Branch No. 2  
Division of Licensing  
U.S. Nuclear Regulatory Commission  
Washington, D.C. 20555

Dear Mr. Schwencer:

Subject: NUCLEAR PLANT NO. 2  
REACTOR CONTAINMENT BUILDING  
INTEGRATED LEAK RATE TEST

- References:
- 1) WNP-2 Final Safety Analysis Report, Washington Public Power Supply System
  - 2) Primary Reactor Containment Leakage Testing for Water Cooled Power Reactors, Code of Federal Regulations, Title 10, Part 50, Appendix J, January 1983
  - 3) Leakage Rate Testing of Containment Structures for Nuclear Reactors, American National Standards Institute, Inc., N.Y., NY; ANSI N45.4-1972

In accordance with the reporting requirements stipulated in reference 2), and in compliance with the testing commitments, regulations, and guidelines specified in references 1), 2), and 3), the Reactor Containment Building Integrated Leak Rate Test, May 1984 is submitted.

Very truly yours,



G. C. Sorensen, Manager  
Regulatory Programs

DAI/tmh  
Enclosure

cc: R Auluck - NRC  
WS Chin - BPA  
AD Toth - NRC Site

*Adm  
1/60*



REACTOR CONTAINMENT BUILDING  
INTEGRATED LEAK RATE TEST

Washington Nuclear Plant Number Two (WNP-2)  
Washington Public Power Supply System  
Richland, Washington

May, 1984

8405310177 840531  
PDR ADOCK 05000397  
P PDR

AOL7S

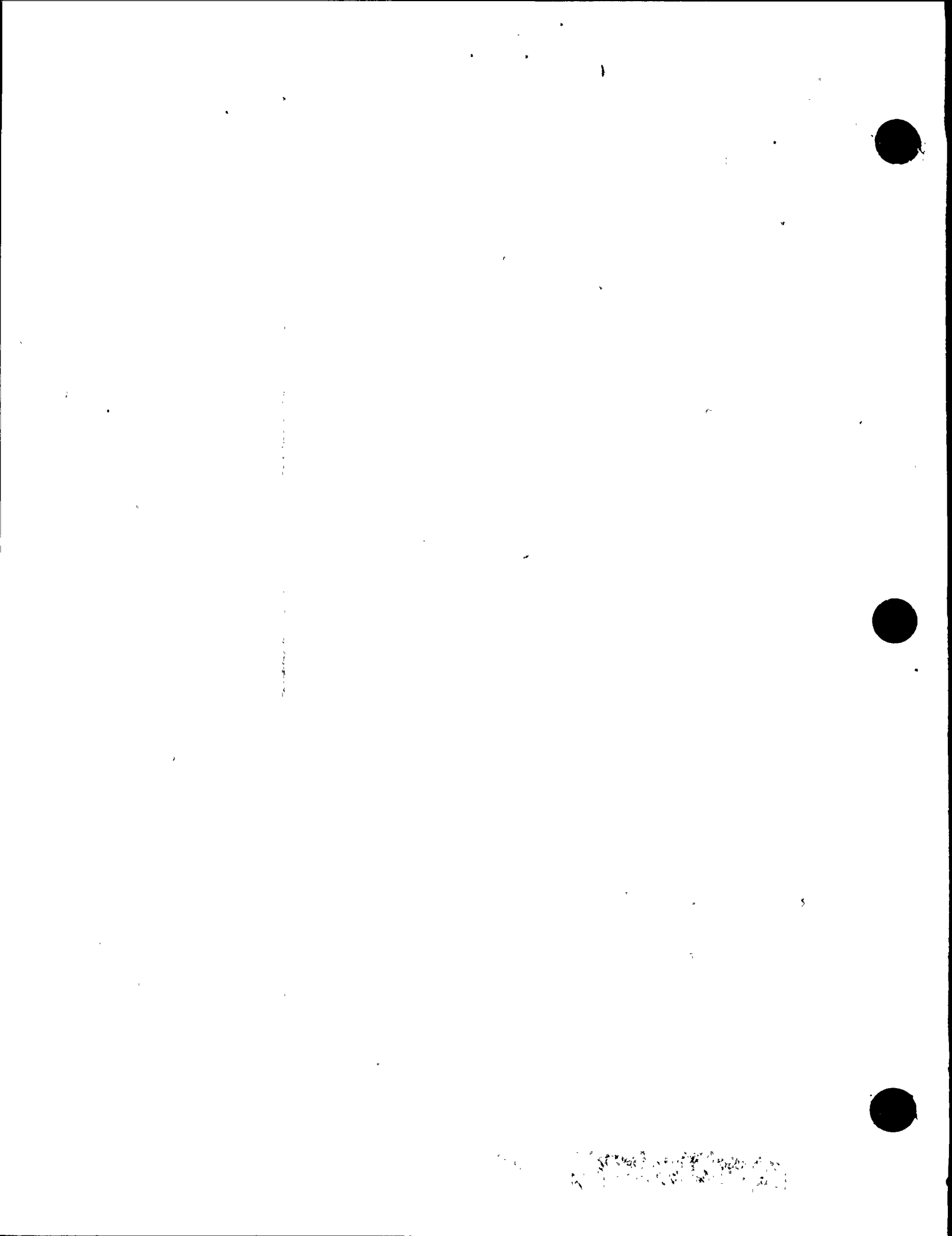

REACTOR CONTAINMENT BUILDING  
INTEGRATED LEAK RATE TEST

Washington Nuclear Plant Number Two (WNP-2)  
Washington Public Power Supply System  
Richland, Washington

May, 1984

PCILRT FINAL REPORT

TABLE OF CONTENTS

<u>SECTION</u>		<u>PAGE</u>
1.0	INTRODUCTION	1
2.0	SUMMARY	2
	2.1 Type B & C Tests	2
	2.2 Type A Tests	2
	2.3 Bypass Leakage Rate Test Sequence	3
	2.4 Acceptance Criteria and Results	3
3.0	DISCUSSION	5
	3.1 Type B & C Tests	5
	3.1.1 Chronology and Methods	5
	3.1.2 Specific Testing Categories	5
	3.1.3 Acceptance Criteria and Results	7
	3.2 Type A Test and the Bypass Leakage Rate Test Sequence	8
	3.2.1 Methods	8
	3.2.2 Data Collection and Reduction	8
	3.2.3 Plant Status During Tests	9
	3.2.4 Major Test Events	10
	3.2.5 Acceptance Criteria and Results	13
4.0	CONCLUSION	20
5.0	REFERENCES	21



PCILRT FINAL REPORT

TABLE OF CONTENTS

ATTACHMENTS

I.	INSTRUMENTATION LIST	2 Pages
II.	INSTRUMENTATION SCHEMATIC	1 Page
III.	INSTRUMENTATION (TEMPERATURE SENSOR) LOCATIONS	3 Pages
IV.	INSTRUMENTATION ERROR ANALYSIS	4 Pages
V.	LEAKAGE RATE CALCULATIONS	11 Pages
	A. Pressure Decay Analysis Methods	
	B. Corrections to the PCILRT and the LRVT Calculated Results	
	C. LRVT Calculations	
	D. Correlation of the BLRT, Fluid Discharge Method, with the BLRT, Drywell Pressure Decay Method	
VI.	DATA SUMMARIES	27 Pages
VII.	GRAPHS	9 Pages
VIII.	GLOSSARY	1 Page



# PCILRT FINAL REPORT

## List of Tables

1. Summary of PCILRT, LRVT, and BLRT Corrected Results
2. LLRT Results for Bypass Leakage Paths Included in the Type C Test Result Summation
3. LLRT Results for the MSIVs
4. Summary of the LLRT Program
5. Valve Lineup Exceptions During the PCILRT and the LRVT
6. Tabulation of the PCILRT, LRVT, and BLRT Results, with Corrections

## 1.0 INTRODUCTION

This report documents the preoperational testing performed on the Primary Reactor Containment of Washington Nuclear Plant Number Two (WNP-2). The plant consists of a GE BWR/5 NSSS System housed within a Mark II Over/Under Containment.

Chronologically, all process lines penetrating the Primary Reactor Containment (PRC) were pneumatically or hydrostatically leakage rate tested and fuel was installed in the Reactor Pressure Vessel (RPV) prior to the performance of the "Primary Containment Integrated Leak Rate Test" (PCILRT) (Ref. 5.11). The PCILRT was conducted from February 3, 1984 to February 16, 1984 and consisted of the 34.7 psig PCILRT proper, performed to quantify the Overall Integrated Leakage Rate (OILR) (see Ref. 5.2) and the Leakage Rate Verification Test (LRVT), the supplemental test performed to verify the veracity of the data collection system (see Ref. 5.2). Next came by a 45 psig pneumatic pressure test of the PRC, a 25 psid Drywell Floor Proof Test, and a series of Drywell Floor Bypass Leakage Rate Tests (BLRT).

This report is organized into three broad topics: SUMMARY, DISCUSSION, and CONCLUSION. Each topic consists of an appropriate level of information pertaining to the Type B & C Tests, the Type A Test, and the BLRTs. Finally, supporting information is provided in the ATTACHMENTS in sufficient detail to justify the CONCLUSIONS and to comply with regulatory and plant requirements (Ref. 5.1, 5.2 and 5.3).

Acronyms used in this report are listed in Attachment VIII.

## 2.0 SUMMARY

### 2.1 Type B & C Tests

The measured leakage rate for the sum of the Type B tests was 1,402.3 sccm and the sum of the Type C tests was 37,325.0 sccm. The allowable leakage rate for the sum of the Type B and C tests was 68,020 sccm (0.6 La); thus, the sum of the measured Type B and Type C leakage rates (38,727.3 sccm) was within the allowable limit.

### 2.2 Type A Test

The plant systems were lined up consistent with the requirements of references 5.1 and 5.2. Emergency Core Cooling Systems (RHR, LPCS and HPCS) were filled and available to perform their safety functions, with RHR Loops A and B used to maintain Reactor Pressure Vessel temperature within Technical Specification (Ref. 5.1) limits. SLC, RWCU, RFW, and the normally water filled portions of the PSR and FPC systems were also filled and, as in the case of RHR, LPCS and HPCS, were vented to see Pa via the head vent. The RCC, RWCU, and CRD systems were filled and operating; therefore, the CIVs in these systems were not exposed to Pa. The remaining systems were drained and vented to both the Primary Reactor Containment Atmosphere as well as outside the outermost CIV to the Reactor Building atmosphere.

The 24-hour PCILRT quantified the Overall Integrated Leakage Rate of the PRC. This was preceded by a three day period, at Pa, wherein minor system leaks were stopped and minor instrumentation problems solved. The PCILRT was followed by the Leakage Rate Verification Test, which was a six hour supplemental test using a constant-rate superimposed leak.

Following the successful completion of the above two tests, a 45 psig pneumatic retest of the Primary Reactor Containment was performed to verify the integrity of selected containment welds.

The recorded 95% Upper Confidence Level (UCL) leakage rate (LR) for the PCILRT was 0.2834 weight percent per day (w/o/day) (based on Total Time Calculated method) which was then corrected for valve lineup exceptions, a wetwell water level drop, and a drywell sump water level increase to give 0.2758 w/o/day. Since 0.75 La is 0.375 w/o/day the leakage rate is less than the acceptance criteria. For the LRVT, the corrected acceptance criteria, based on a superimposed constant leakage rate of 0.5210 w/o/day, the calculated Total Time PCILRT LR of 0.2110 w/o/day, and a correction factor, was 0.7328 w/o/day + 0.125 w/o/day. The Total Time Calculated Leakage Rate, corrected for valve lineup test exceptions, was 0.6282 w/o/day; thus, the LRVT substantiated the validity of the PCILRT results.

### 2.3 Bypass Leakage Rate Test Sequence

The plant status during these tests was the same as during the PCILRT except that a flow path was created from the closed up Wetwell during a portion of these tests (see Table 5).

The sequence consisted of 25, 15, 5, and 1.5 psid tests performed after a 25 psid proof test of the Drywell Floor (DF) was conducted. The proof test was done to assure the structural integrity of the concrete floor and the annular stainless steel "Omega Seal" connecting the outer perimeter of the DR with the PRC shell.

The various acceptance criteria, based on the maximum allowable equivalent orifice size interconnecting the Drywell with the Wetwell (0.0045ft<sup>2</sup>), were 128.5, 128.4, 116.8, and 78.4 w/o/day respectively for the 25, 15, 5, and 1.5# BLRTs. The respective Total Time 95% UCL results were 28.3, 23.0, 8.0 and 4.0 w/o/day.

### 2.4 Acceptance Criteria and Results

The tabulated tests were performed with the results indicated in Table 1.

Test	Acceptance Criteria (W/O/Day)	Corrected Results	
		Total Time (W/O/Day)	Mass Point (W/O/Day)
PCILRT	$\leq 0.375$ <sup>4</sup>	0.2758 <sup>1</sup>	0.2264 <sup>1</sup>
LRVT	$0.7328 \pm 0.125$ <sup>5</sup>	0.6282 <sup>2</sup>	0.6440 <sup>2</sup>
25# BLRT	$\leq 128.56$	28.3393 <sup>1</sup>	25.7505 <sup>1</sup>
15# BLRT	$\leq 128.46$	22.9959 <sup>1</sup>	22.5140 <sup>1</sup>
5# BLRT	$\leq 116.86$	8.0088 <sup>1</sup>	8.9455 <sup>1</sup>
1.5# BLRT	$\leq 78.46$	4.0407 <sup>1</sup>	3.7680 <sup>1</sup>

TABLE 1

Summary of PCILRT, LRVT, and BLRT Corrected Results



NOTES:

PCILRT - Primary Containment Integrated Leakage Rate Test

LRVT - Leakage Rate Verification Test

BLRT - Bypass Leakage Rate Test

1. 95% UCL Value (PCILRT Corrected)
2. Calculated, corrected
4. Based on 0.75 La, where La = 0.5 W/O/day
5. Based on an induced leakage rate of 0.5210 w/o/day, a calculated Primary Containment Integrated Leakage Rate of 0.2110 w/o/day, and a correction factor of 0.0008 w/o/day.
6. Based on the leakage rate to be expected from the drywell if the leakage path were an orifice with an  $A/\sqrt{K}$  value of 0.0045 ft<sup>2</sup>.



### 3.0 DISCUSSION

#### 3.1 Type B & C Tests

##### 3.1.1 Chronology and Methods

The Type B and C Record Tests were performed under the Startup Test Program during the time period of January 4, 1983 through February 7, 1984.

The Pneumatic Type B & C Tests were performed utilizing the Pressure Decay and Makeup Flowrate methods. Hydrostatic Type C testing on water sealed valves was accomplished using the Makeup Flowrate method.

##### 3.1.2 Specific Testing Categories

The first categories are the air and nitrogen-tested Type B and Type C penetrations. The measured leakage rate for the sum of the Type B tests was 1,402.3 sccm and the sum of the Type C tests was 37,325.0 sccm. The allowable leakage rate for the sum of the Type B and C tests was 68,020 sccm (0.6 La); thus, the sum of the measured Type B and Type C leakage rates (38,727.3 sccm) was within the allowable limit.

The second category is a subset of the above Type C tests, being the measured leakage rates on the secondary containment bypass lines that must be included in the sum of the Type B & C Tests (X-14, RWCU from the Reactor Vessel; X-22, MS drain; X-77Aa, RRC sample; and X-92, DW service to the Drywell). The allowable and measured leakage rates are tabulated in Table 2.

Penetration	Service	Leakage Rate	
		Allowable (SCCM)	Measured (SCCM)
X-14	RWCU from the Reactor Vessel	≅ 165	19.5
X-22	MS Drain	≅ 89	29.71
X-77Aa	RRC Sample	≅ 23	317.62
X-92	DW Service to the Drywell	≅ 61	0.0

TABLE 2

LLRT Results for Bypass Leakage Rate Paths Included in the Type C Test Result Summation

- NOTES: 1. Retested subsequent to the PCILRT (on 3-16-84), at which time the measured leakage rate was 42.5 sccm.
2. The PCILRT was performed with this penetration as a documented deficiency in that the outboard one inch solenoid operated globe valve did not meet the bypass leakage rate limit (see 3.2.4). The inner valve did meet the acceptance criteria. The valves were both left closed during the test and the line outside the outboard valve was vented to the Reactor Building atmosphere. The valve was subsequently repaired and retested (on March 24, 1984), resulting in a measured leakage rate of 20.6 sccm for this penetration.

A special case of the above category makes up the third category and applies to the Main Steam Isolation Valves (MSIVs). They are similar to the second category in that any process line leakage passes directly from the PRC to the Turbine Building, thereby "bypassing" the SGT System. The line leakage is not added to the sum of the Type C leakage rates because the Main Steam Leakage Control System intercepts all leakage past the inboard CIV up to the allowable limit (See Ref 5.1). The allowable leakage rate is 5420 sccm per valve and the test results are tabulated in Table 3. Testing was performed at a test pressure of 25 psig (per Ref. 5.1).

Penetration	Leakage Rate <sup>1</sup> (SCCM)
X-18A	3000
X-18B	2512
X-18C	4399
X-18D	51962

TABLE 3

LLRT Results for the MSIVs

- NOTES: 1. Pressure decay test performed between the inboard MSIV and the outboard MSIV; therefore, the LRs assigned to the penetrations are conservative with respect to the acceptance criteria.

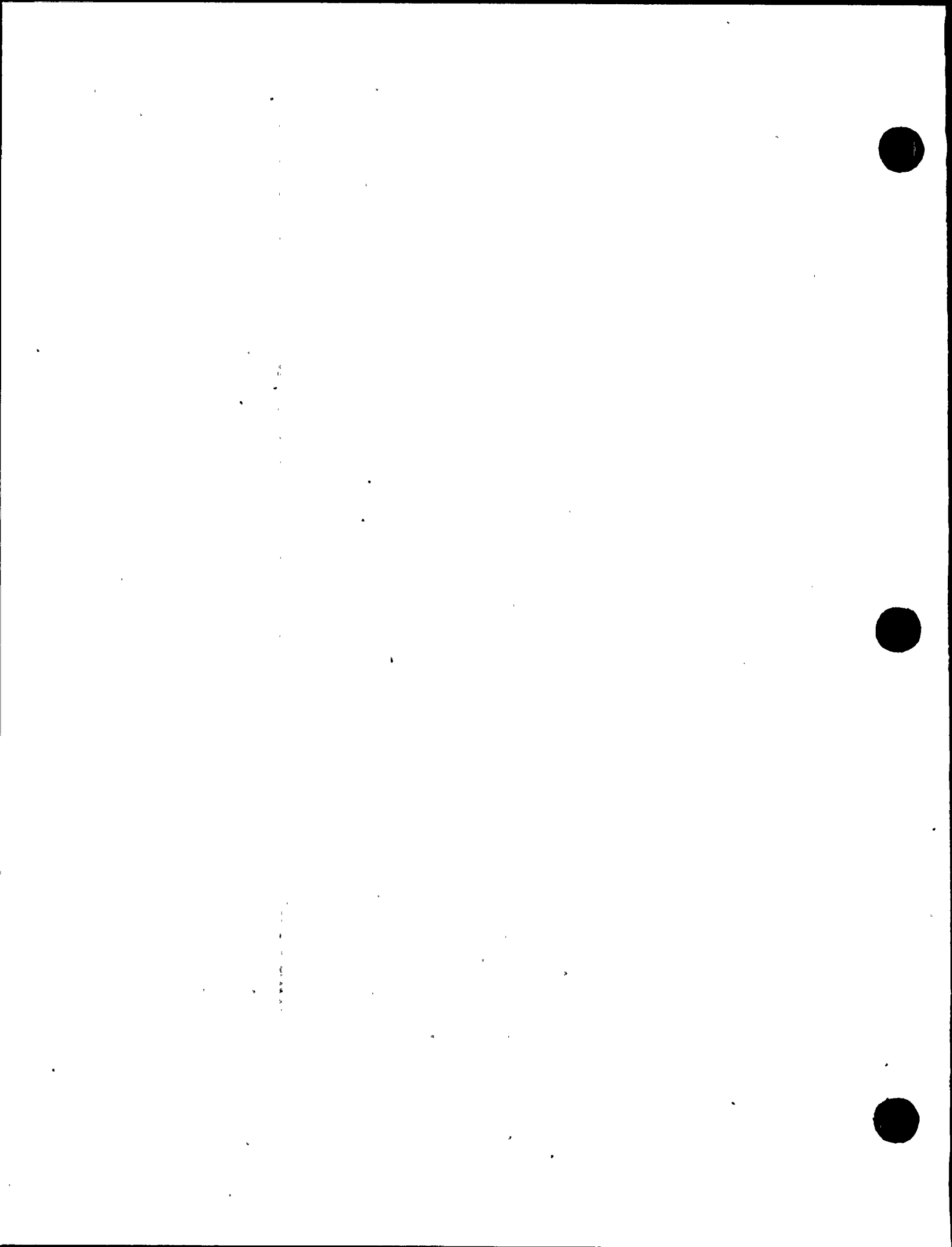

2. During the stabilization period prior to the PCILRT this penetration appeared to have a leakage rate exceeding the allowable value (a rotometer was put on the test connection between the MSIV's while the Primary Reactor Containment was at pressure), but when tested subsequent to the PCILRT, this penetration had a leakage rate of 4024 sccm. The former value was utilized in the LLRT Program; thus, it was retained.

The fourth, and last, category pertains to Containment Isolation Valves (CIV) sealed with fluid from a seal system (Ref. 5.2). Hydrostatic tests were performed on many valves sealed by water during an accident event requiring Primary Reactor Containment integrity. The sum of the leakage rates obtained by makeup leakage rate tests performed at 1.1 Pa was 0.0 gpm. This value is not required to be included in the sum of the Type B & C leakage rates (see refs. 5.1 and 5.2).

### 3.1.3 Acceptance Criteria and Results

Table 4 summarizes the LLRT program.

Category	Acceptance Criteria (SCCM)	Results (SCCM)
Type B	---	1,402.3
Type C (Air, N <sub>2</sub> )	---	37,325.0
Σ B & C	≤ 68,020	38,727.3
Type C (Bypass) <sup>1</sup>	≤ 23	317.6
Type C (MSIV) <sup>2</sup>	≤ 5,420	5,196
Type C (Hydrostatic)	≤ 1.0 GPM <sup>3</sup>	0.0 GPM

TABLE 4

#### Summary of the LLRT Program

- NOTES:
1. The worst case is listed. Refer to Table 2 for discussion.
  2. Again, the worst case is listed (X-18D).
  3. Per valve Acceptance Criteria.

## 3.2 Type A Test and the Bypass Leakage Rate Testing Sequence

### 3.2.1 Methods

The absolute method of pressure decay testing was used for the PCILRT, the LRVT, and the BLRT sequence (Drywell Pressure Decay). In addition to using the Drywell Pressure Decay Testing method on the BLRT sequence the fluid discharge method of leakage rate measurement was used for the two lowest of the four BLRT pressures. This method uses a flow measurement device (BLFI-1 of Figure II.1), attached to a singular Wetwell to Reactor Building vent path, to measure the rate of air ("fluid") "discharge" from the Wetwell after dynamic equilibrium is attained with the leakage from the Drywell to the Wetwell. The method was used to give a benchmark correlation with the standard pressure decay BLRT for future reference such that fluid discharge testing might be used in the future in lieu of the more time consuming pressure decay testing for the BLRT sequence.

### 3.2.2 Data Collection and Reduction

The Data Acquisition System consisted of 18 drybulb temperature probes, 6 dew cells and 2 pressure sensors. Attachment III, Table III.1 and Figure III.1 present the location of each sensor, and Attachment III, Table III.2 presents the volume of each containment subvolume. The sensors were connected to a Volumetrics Integrated Leak Rate Monitoring System (ILRMS), model 14629LC (Ref. 5.4), which printed out the measured value of each drybulb sensor and dew cell every 15 minutes. The quartz crystal pressure transducer outputs were continuously displayed on a digital readout panel and were manually recorded every 15 minutes. The pressure data were corrected using calibration data. Sensor data were entered into the ILRT computer program (Ref. 5.12) through a CRT located near the Data Acquisition System (DAS). The CRT terminal was connected to the WNP-2 plant computer, located in the Control Room, into which the ILRT program was loaded. Hardcopy printouts were obtained from the printer located in the Control Room.

The computer program printouts consisted of individual sensor data, averaged sensor data, air partial pressure, calculated dry air mass and leakage rate. The program also allows determination of temperature stabilization based on Reference 5.6. The program allows the operator to examine and correct any data at any point in time. Plots of average temperature, dew point, pressure and leakage rate may be displayed on the CRT and can be printed at any time. Examples are shown in Attachment VII. The program was developed in-house and was verified against data and results accepted for a prior ILRT at another plant.



Reference 5.1 committed WNP-2 to using Reference 5.3 as the basic document for PRC leakage rate testing; therefore, there are two possible calculation methods that could be used for the reduction of the data for the PCILRT, the LRVT, and the pressure decay method of the BLRT: The Total Time method and the Point to Point method. Of the two, the Total Time method has been chosen as the basic method for this report. References 5.5 and 5.6 present the superior Mass Point method, which was also used for data reduction, the results of which are included for information only.

### 3.2.3 Plant Status During Tests

The systems were placed in the following four broad categories:

- A. Systems filled with water and not vented to the Primary Reactor Containment atmosphere.
  - 1. Reactor Closed Cooling (RCC)
  - 2. Control Rod Drive (CRD)
  - 3. Reactor Recirculation (RRC), Seal Injection
- B. Systems filled with water but vented to the Primary Reactor Containment atmosphere.
  - 1. Residual Heat Removal (RHR)
  - 2. High Pressure Core Spray (HPCS)
  - 3. Low Pressure Core Spray (LPCS)
  - 4. Standby Liquid Control (SLC)
  - 5. Reactor Water Cleanup (RWCU)
  - 6. Reactor Feed Water (RFW)
  - 7. Post Accident Sampling (PSR), Water-filled Portions
  - 8. Fuel Pool Cooling (FPC), Supply
- C. Systems On-Line
  - 1. Control Rod Drive (CRD)
  - 2. Reactor Recirculation (RRC), Seal Injection





3. Residual Heat Removal (RHR), A and B Loops
4. Reactor Water Cleanup (RWCU)
5. Containment Atmosphere Control (CAC)\*
6. Sample Handling Equipment Hydrogen Oxygen Monitors
7. Reactor Closed Cooling (RCC)

\*CIV's open but air pumps not running

- D. All other systems penetrating the PRC were drained and vented to the PRC atmosphere as well as the to Reactor Building atmosphere.

In the above listing all of the CIVs were closed except those used for specific purposes (e.g. X-42d: inboard CIV opened to give a flow path during the LRVT).

#### 3.2.4 Major Test Events

Section 3.2 deals with the testing performed by Reference 5.1 and consisted of the following six major phases:

1. Temperature and Pressure Stabilization
2. 24 Hour PCILRT
3. 4 Hour (Induced) LRVT
4. 45 Psig Pneumatic Weld Test
5. 25 Psid DF Proof Test
6. Drywell Floor Bypass Leakage Rate Tests

#### Temperature and Pressure Stabilization

Pressurization of the containment began at 1143 on February 7, 1984. The ILRT test pressure,  $P_a$ , was reached at 0530 on February 8. Data were continuously collected from this time up to the conclusion of the ILRT test at 0339 on February 12. While temperature stabilization was reached within a few hours after the pressurization was completed, the official 24 hour run was not started until a number of leaks were located and corrected and some instrumentation problems resolved.



8



### Primary Containment Integrated Leakage Rate Test

The ILRT test was initiated at 0329 on February 11. The total containment pressure at this time was 49.552 psia (34.046 psig). Data were collected at 15 minute intervals and were uneventfully continued for 24 hours.

### Leakage Rate Verification Test

A six hour flow verification test was run immediately following the ILRT test. The verification test provides a method for assuring that systematic error or bias is given adequate consideration. This test consisted of superimposing a known leakage rate upon the existing leakage rate.

The verification test was started at 0415 on February 12 with an average superimposed LR of 4.00 scfm, which corresponds to a LR of 0.5210 w/o/day (see Attachment V.C).

### 45 Psig Pneumatic Test

Various PRC pressure boundary welds had been made subsequent to the original PRC Structural Integrity Test (performed in 1975); therefore, a pneumatic pressure test was run at Pd to verify the integrity of these welds.

This test was performed to meet ASME Code and Washington State requirements and not to meet Reference 5.2 requirements; hence, LR data were not obtained. The accessible welds were successfully inspected.

### 25 Psid DF Proof Test

The Drywell was pressurized to 25 psig with the Wetwell vented to the Reactor Building, held there for 15 minutes, then depressurized to 18 psig, at which time the Wetwell was entered and the underside of the DF was inspected for leaks. Some small thru-leakage exit points were identified but the larger leakage paths appeared to be by the Downcomer Test Plugs situated at the bottom end of each of the 102 downcomers (blowdown tubes from the Drywell to the Suppression Pool in the Wetwell). It was decided to continue testing and quantify these leakage rates.

### Bypass Leakage Rate Tests

Four drywell floor Bypass Leakage Rate Tests were performed to assure that the total drywell to wetwell leakage area,  $A/\sqrt{K}$ , is less than 0.0045 ft<sup>2</sup>. Tests were run with differential pressures of 25, 15, 5 and 1.5 psid across the drywell floor. These tests were performed by pressurizing the drywell to the desired differential pressure above the wetwell. Then the drywell temperature, dewpoint and pressure data were collected using the same instrumentation used for the ILRT. Using the collected data, the total drywell leak rate was determined. This leakage rate consisted of the composite of drywell to wetwell leakage and external leakage. The allowable DF leakage rate is much greater than the allowable ILRT leakage rate; therefore, it is conservatively assumed that the measured leak rate is from bypass leakage only.

The 25 and 15 psid tests were performed with each of the 102 downcomers sealed by inflatable plugs. Since the downcomers are submerged by 12 feet of water (equivalent to 5.2 psid) the 5 psid and 1.5 psid tests were performed without the downcomers being sealed. Each pneumatically sealed plug had a small vent plug in the center which was removed for these low pressure tests. These low pressure tests were performed to provide a benchmark for future bypass leakage tests which will be performed with differential pressures of 5 psid or less.

Two additional bypass leakage tests were performed at 5 and 1.5 psid using a fluid discharge method of measuring leakage. This method consisted of maintaining a relatively constant drywell pressure and venting the wetwell through a calibrated flow meter; thus, the air ("fluid") that bypassed the DF and was "discharged" out the singular Wetwell exit (X-25A, Wetwell Spray Line) was measured for flow rate. Since the leakage rate across the DF was so small at these differential pressures it was not necessary to make up any air at all in the Drywell for the duration of each low pressure test using the Fluid Discharge Method.

This method may be used for future bypass testing. It is certainly capable of performing bypass leakage screening tests to determine if bypass leakage is near or above the acceptance criteria.



### 3.2.5 Acceptance Criteria and Results

#### Temperature Stabilization

The acceptance criteria used for the PCILRT was:

- 1) "The rate of change of the weighted average PRC air temperature, linearly averaged over the latest four consecutive dry bulb data sets, is less than 0.5°F/h.
- 2) Time elapsed from the completion of [the pressurization of the PRC to Pa] is four or more hours." (Ref. 5.11)

This was easily met, as was the more stringent requirement given in Ref. 5.6. This method requires that the absolute average temperature change per hour over the last 4 hours minus the absolute average temperature change per hour over the last hour be less than 0.5°F. The result of using this last analysis method, performed for information purposes only, is given in Attachment VI, Table VI.1, which presents the average dry bulb temperature, the 1 hour, 4 hour, and 4 hour minus 1 hour calculations for the time period of 2195 on February 10 to 0559 on February 11. As can be seen, the 4 hours minus 1 hour differential was less than 0.01°F, which meets the requirements of Ref. 5.6.

The above time period partially coincides with the start of the PCILRT but that fact is not significant because the temperature and pressure were stable, by the acceptance criteria used for this test, from 0744 on February 9, 1984 until the testing sequence was completed.

#### Primary Containment Integrated Leakage Rate Test

The acceptance criteria for the PCILRT is that the measured 95 percent UCL leakage rate,  $L_{am, 95\%}$ , be less than 75 percent of the maximum allowable leakage rate,  $L_a$ .  $L_a$  is 0.5 percent per day and 75 percent of  $L_a$  is 0.375 percent per day. Therefore, the 95 percent UCL leakage rate,  $L_{am, 95\%}$ , must be less than 0.375.

The average temperature, pressure and air mass for the 24-hour ILRT are presented in Attachment VI, Tables VI.2 and VI.3. Figures VII.1 through VII.4, Attachment VII, present the time history of average temperature, dewpoint, pressure, and air mass.

Attachment VI, Table VI.4 presents the summary of the leakage rate calculation based on the Total Time method. The Total Time 95% UCL leakage rate  $L_{am}$ , 95% for the 24 hour test was 0.2834 percent per day, which is well below the acceptance criteria of 0.375 percent per day. The column labeled calculated leakage rate is the calculated mean leakage rate.

The leakage rate calculated by the mass point method is presented in Table VI.5. The 95 percent UCL leak rate,  $L_{am}$ , 95% based on the mass point method was 0.2340 percent per day which is well below the acceptance criteria of 0.375 percent per day.

The PCILRT calculated result was corrected for the effects of improper valve lineup and water inventory changes, which are discussed below.

The effects caused by the improper valve lineup used during the PCILRT (and the LRVT) are tabulated in Table 5.

Penetration	Valve Numbers	Exception Discussion	Leakage Rate <sup>3</sup> (SCCM)
X-8	LPCS-V-6	MOV that was manually closed	48.00 ± 45.13
X-22	MS-V-16 & MS-V-19	Not vented to Reactor Building	5.92 ± 5.08
X-53	CSP-V-800-2 CSP-V-800-24 CSP-V-96 CSP-V-97	Common line blocked; therefore, valves did not see Pa	11.41 ± 7.62 10.33 ± 8.09
X-661	CSP-V-11 CSP-V-23	Used for PI-1 tap (Wetwell pressure)	43.97 ± 8.00
X-42d2	PI-VX-42d PI-V-216	Used for LRVT flow Path	5.40 ± 7.74

TABLE 5

Valve Lineup Exceptions During the PCILRT and the LRVT

NOTES: 1. Used in lieu of an instrument line.

2. Used only during the LRVT.

3. Refer to Table IV.1 for details.





Statistically combining the first four factors of Table 5 adds 167.1 sccm to the PCILRT leakage rate, which is equivalent to 0.00077 w/o/day (see Attachment V.B). All five factors were statistically summed to add 173.2 sccm to the LRVT result (discussed later). This is equivalent to 0.00080 w/o/day (see Attachment V.B).

Two other correction factors were applied to the PCILRT results:

- 1) The suppression pool (located in the wetwell) level decreased 0.2 inches during the course of the PCILRT, and
- 2) The drywell sump collected 9 inches of water during the course of the PCILRT.

The former factor subtracted 0.02184 w/o/day from the PCILRT leakage rate and the latter factor added 0.01346 w/o/day to the PCILRT leakage rate (see Attachment V.B).

Thus, the correction factor that was applied to the calculated 95% UCL LR was -0.00761 w/o/day, which resulted in a Total Time 95% UCL LR of 0.2758 w/o/day.

#### Leakage Rate Verification Test

The acceptance criteria for the Leakage Rate Verification test is:

$$(L_0 + L_{am} - 0.25 L_a) \leq L_c \leq (L_0 + L_{am} + 0.25 L_a)$$

where:  $L_0$  = Known superimposed leakage rate, w/o/day  
 $L_{am}$  = Previously measured leakage rate, w/o/day  
 $L_a$  = Maximum allowable leakage rate, w/o/day  
 $L_c$  = Measured composite leakage rate, w/o/day

The superimposed leakage rate should be between 75 to 125 percent of  $L_a$ .

Data were collected at 15 minute intervals. Attachment VI, Tables VI.6 and VI.7 present the data summary for the test. Attachment VI, Table VI.8 presents the leakage rate calculation based on the Total Time method. The mean calculated composite leakage rate,  $L_c$ , was 0.6274 percent per day. The leakage rate based on a Mass Point calculation is given, for information only, in Attachment VI, Table VI.9.

Correcting  $L_c$  for the valve lineup factor previously presented (173.2 sccm, or 0.00080 w/o/day) gives 0.6282 w/o/day.

Based on corrected lower and upper band limits of 0.6078 w/o/day and 0.8578 w/o/day, respectively, it is apparent that the instrumentation accurately tracked actual PRC atmospheric parameters.

Therefore, the LRVT was successfully passed and the agreement between the expected and measured LRs indicates that systematic errors were not a factor in the performance of the PCILRT.

#### Bypass Leakage Rate Test Sequence

The acceptance criteria used for the Bypass Leakage Rate Tests were based on the leakage rate which would occur if the total leakage area ( $A/\sqrt{K}$ ) was 0.0045 ft<sup>2</sup> at the applied differential pressure. The acceptable leakage rates for the tests were 128.5, 128.4, 116.8, and 78.4 percent per day for the 25, 15, 5 and 1.5 psid tests respectively.

Attachment VI, Tables VI.10 through VI.25, present the data and results of the Bypass Leakage Rate Tests. The 95 percent upper confidence leakage rates, calculated using the Total Time method, were 28.34, 23.00, 8.01 and 4.04 percent per day for the 25, 15, 5 and 1.5 psid tests respectively. These tests show the bypass leakage was only about 22 percent of the acceptance criteria for the high pressure tests and less than 6 percent of the acceptance criteria for the 5 and 1.5 psid tests. The most likely reason for the reduced LRs obtained during the low pressure BLRTs may have been leakage around the inflatable downcomer plugs during the high pressure BLRTs. These tests demonstrated that the DF bypass leakage area is much less than 0.0045 ft<sup>2</sup> ( $A/\sqrt{K}$ ).

The acceptance criteria restated in units of scfm were 218 and 120 scfm for the 5 and 1.5 psid tests, respectively. The discharge flows measured were 17 and approximately 6 scfm for the 5 and 1.5 psid tests, respectively. The equivalent LRs for 17 scfm and 6 scfm were 12.8 w/o/day and 4.5 w/o/day, respectively, which, when compared to the 95% UCL Drywell pressure decay-type bypass leakage rates, were 60% higher than the 5# BLRT and 12% higher than the 1.5# BLRT. These errors could have been expected because of the larger differential pressure across the DF during the final stages of the readings (e.g. the differential pressures for the 5# BLRT, pressure decay, were 5.037 psid at the start and 4.515 psid at the end, whereas the differential pressures for the 5# BLRT, fluid discharge, were

4.791 psid at the start and 5.152 psid at the end, which was when the 17 scfm reading was taken). The accident pressure trend would be better represented by the former conditions; therefore, the BLR obtained via the latter method would agree better with the BLR obtained via the former method if proper corrections were applied to compensate for the differing differential pressures. This was not done herein but, if warranted, it may be considered in the future. Since the method appears to be conservatively adequate, it may be used for determining future Bypass Leakage Rates.

An exception to the 15 psid BLRT acceptance criteria occurred during the test. Instead of commencing the test at an originally planned differential pressure of 15 psid to 15.5 psid it was started with a DF differential pressure of only 14.23 psid. But the 15# BLRT acceptance criteria of 128.4 w/o/day was based on a 15 psid differential. Since the actual leakage rates for all of the BLRTs were well under all of the acceptance criteria this pressure deviation was not considered to be significant.

The BLRTs were not corrected for valve lineup deficiencies because the acceptance criteria were large compared with the correction and the calculated leakage rates were all well under these acceptance criteria.

Based on inspection made before the 25 psid proof test and at the 18 psid hold point immediately following the proof test, no visible structural deformation of the DF was caused by the 25 psid differential. This DF integrity was subsequently quantitatively verified by the follow-on BLRTs, as discussed above.

Comparison of Results with Acceptance Criteria

The acceptance criteria and results for all tests are presented in Table 6.

Test	Date Completed	Acceptance Criteria (w/o/day)	Results		Corrections (w/o/day)	Reported Results (Total Time) (w/o/day)	
			Total Time (w/o/day)	Mass Point (w/o/day)			
PCILRT	2-12-84	$\leq 0.375^4$	0.2834 <sup>1</sup>	0.2340 <sup>1</sup>	-0.0076	0.2758 <sup>1</sup>	
LRVT	2-12-84	$0.7328 + 0.125^5$	0.6274 <sup>2</sup>	0.6432 <sup>2</sup>	0.0008	0.6282 <sup>2</sup>	
25# BLRT	2-15-84	$\leq 128.5^6$	28.3393 <sup>1</sup>	25.7505 <sup>1</sup>	0.0	28.3393 <sup>1</sup>	
15# BLRT	2-15-84	$\leq 128.4^6$	22.9959 <sup>1</sup>	22.5140 <sup>1</sup>	0.0	22.9959 <sup>1</sup>	
5# BLRT	2-15-84	$\leq 116.8^6$	8.0088 <sup>1</sup>	8.9455 <sup>1</sup>	0.0	8.0088 <sup>1</sup>	
1.5# BLRT	2-16-84	$\leq 78.4^6$	4.0407 <sup>1</sup>	3.7680 <sup>1</sup>	0.0	4.0407 <sup>1</sup>	
		Acceptance Criteria (SCFM)   (w/o/day)		Measured Results			
				Indicated (SCFM)	Equivalent (w/o/day)		
5# BLRT <sup>3</sup>	2-16-84	218 <sup>7</sup>	116.8 <sup>6</sup>	17	12.8	0.0	Note 9
1.5# BLRT <sup>3</sup>	2-16-84	120 <sup>7</sup>	78.4 <sup>6</sup>	$\sim 6^8$	$\sim 4.5^8$	0.0	Note 9

TABLE 6

Tabulation of the PCILRT, LRVT, and BLRT Results with Corrections

NOTES:

1. 95% UCL Value
2. Calculated
3. Fluid Discharge Method (i.e. measured flow across DF via a singular wetwell exit).
4. Based on 0.75 La, where La = 0.5 w/o/day
5. Based on an induced leakage rate of 0.5210 w/o/day, a calculated Primary Containment Integrated Leakage Rate of 0.2110 w/o/day, and a correction factor of 0.0008 w/o/day.
6. Based on the leakage rate to be expected from the drywell if the leakage path were an orifice with an  $A/\sqrt{K}$  value of 0.0045 ft<sup>2</sup>.
7. Equivalent flow rates in standard units based on the criterion specified in note 6, above.
8. The flow instrument was not calibrated below 10 scfm.
9. These results are for information only.

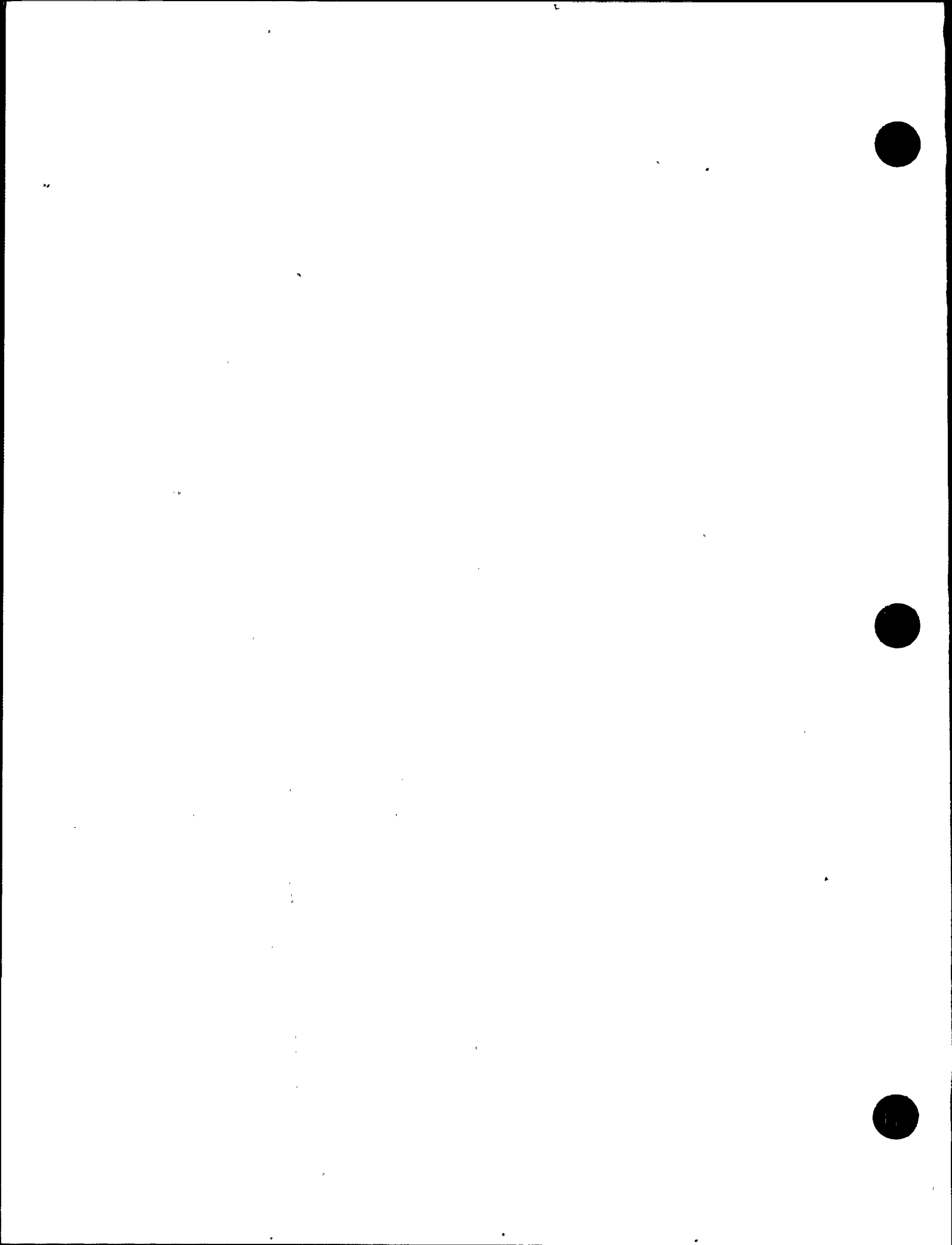

#### 4.0 CONCLUSION

The Type B & C tests (Local Leakage Rate Tests) were successfully completed on February 7, 1984, with a total measured leakage rate of 38,727.3 SCCM ( $0.3416L_a$ ) thereby enabling the successful completion of the Type A Test (the Primary Containment Integrated Leakage Rate Test, or PCILRT) on February 12, 1984. The 95% UCL leakage rate ( $L_{am, 95\%}$ ) was 0.2834 w/o/day ( $0.567L_a$ ) which, when corrected for valve lineup exceptions and water level changes inside the Primary Reactor Containment, was 0.2758 w/o/day, still well under the allowable leakage rate of 0.375 w/o/day. With  $L_a$  superimposed upon  $L_{am}$  during the Leakage Rate Verification Test, the calculated leakage rate was 0.6274 w/o/day, or 0.6282 when corrected for valve lineup exceptions. This leakage rate is within the allowable corrected composite leakage rate band of 0.6078 w/o/day to 0.8578 w/o/day; therefore, the LRVT was successfully passed and the agreement between the expected and measured LRs indicate that systematic errors were not a factor in the performance of the PCILRT.

The Bypass Leakage Rate Testing sequence followed the successful 45 psig pneumatic retest of the Primary Reactor Containment and the successful 25 psid pneumatic proof test of the Drywell Floor. The sequence consisted of consecutive 25 psid, 15 psid, 5 psid and 1.5 psid tests with the attendant 95% UCL Drywell Floor leakage rates predictably decreasing with the differential pressure from 28.34 w/o/day down through 23.00, 8.01, and 4.04 w/o/day. The respective allowable leakage rates were 128.5, 128.4, 116.8, and 78.4 w/o/day. The Bypass Leakage Rate Tests were successful in proving that the effective sum ( $A/\sqrt{K}$ ) of the Drywell Floor leakage paths were less than 0.0045 ft<sup>2</sup> for all test conditions.

The independent measurements made of the 5# Bypass Leakage Rate and the 1.5# Bypass Leakage Rate by utilizing the fluid discharge method conservatively agree with the above calculated values (see Table 6); therefore, this more direct Bypass Leakage Rate measurement method may be exclusively considered for future Bypass Leakage Rate Tests.

All tests met their respective acceptance criteria; therefore, this test sequence was successful.

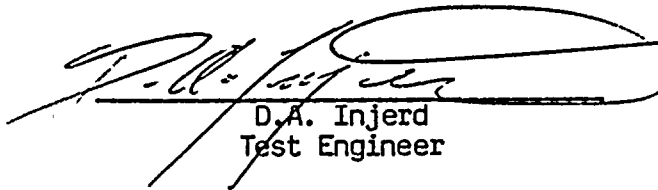

D.A. Injerd  
Test Engineer





## 5.0 REFERENCES

- 5.1 WNP-2 Final Safety Analysis Report, Washington Public Power Supply System.
- 5.2 Primary Reactor Containment Leakage Testing for Water Cooled Power Reactors, Code of Federal Regulations, Title 10, Part 50, Appendix J, January 1983.
- 5.3 Leakage Rate Testing of Containment Structures for Nuclear Reactors, American National Standards Institute, Inc., N.Y., NY; ANSI N45.4 1972.
- 5.4 ILRT Console Operation, Volumetrics, Inc., for Model 14629-LC.
- 5.5 Containment System Leakage Testing Requirements, American Nuclear Society, LaGrange Park, IL; ANSI/ANS-56.8-1981.
- 5.6 Containment System Leakage Testing Requirements, American Nuclear Society, LaGrange Park, IL; N274, Draft No. 2, Revision 3, November 15, 1978.
- 5.7 Daniels and Aberty, Physical Chemistry, John Wiley & Sons, New York, 1955.
- 5.8 R.C. Reid, J.M. Prauznitz and T.K. Sherwood, The Properties of Gas and Liquids, 3rd Edition, 1977, McGraw Hill Book Company.
- 5.9 J.H. Keenan, F.G. Keyes, P.C. Hill and J.G. Moore, Steam Tables, John Wiley & Sons, New York, 1969.
- 5.10 O.A. Hougen, K.M. Watson and R.A. Ragatz, Chemical Process Principles, Part 1, 2nd Edition, McGraw Hill Book Company, 1956.
- 5.11 Primary Containment Integrated Leak Rate Test, WNP-2 Pre-Operational Test Number PT 201.0-A, Revision 1, with Two Test Change Notices, February 2, 1984.
- 5.12 Integrated Leak Rate Test Analysis, Washington Public Power Supply System, February 1984.



ATTACHMENT I  
INSTRUMENTATION LIST

Table I.1 - Instrumentation Data

Instrument	Make	Model	Accuracy	Cal Range	Cal Date	Sensitivity <sup>5</sup> (E) <sup>6</sup>	Repeatability <sup>5</sup> or Resolution (E) <sup>6</sup>
Drybulb Temp <sup>1</sup>	Rosemount	78-65-17	± 0.5°F	50-120°F	12-16-83	0.036°F	0.01°F
Dewpoint <sup>1</sup>	Foxboro	2711AG	± 2.0°F	-10-90°F	12-23-83	0.5°F	0.01°F
Pressure <sup>1</sup>	Mensor	10100-001	+ 0.002% FS + 0.010% RDG	0-100 PSIA	12-16-83	0.001 PSIA	0.0005 PSIA
LRVT Flow <sup>1</sup>	Volumetrics/ Kurz	14629/505-9	+ 1% FS + 4% FS	0-10 SCFM 10-15 SCFM	01-09-84 01-09-84	0.025 SCFM	0.05 SCFM
Drybulb Temp <sup>2</sup>	Volumetrics	---	+ 0.1% RDG	50-120°F	12-14-83	---	---
Dewpoint <sup>2</sup>	Volumetrics	---	+ 0.1% RDG	60-90°F	12-14-83	---	---
Drybulb Temp <sup>3</sup>	Fluke	80T-150	+ 0.1°F + 1.42°F	32-104°F 104-212°F	01-26-84 01-26-84	---	---
Dewpoint <sup>3</sup>	Environmental Tectronics	---	+ 0.3°F	32-104°F	01-25-84	---	---
Pressure <sup>3</sup>	Heise	CMM 60	+ 0.1% FS	0-60 PSIG	01-19-84	---	---
LRVT Flow <sup>3</sup>	Fisher-Porter	10A	+ 2% FS	2-10 SCFM	01-24-84	---	---
Drybulb Temp <sup>4</sup>	---	---	+ 0.98°F	78-110°F	2-3/6-84	---	---
Dewpoint <sup>4</sup>	---	---	+ 2.8°F	43-74°F	2-3/7-84	---	---
Pressure <sup>4</sup>	---	---	+ 0.08% RDG	0-60 PSIG	02-04-84	---	---
LRVT Flow <sup>4</sup>	---	---	+ 2.3% FS	2-10 SCFM	02-09-84	---	---



ATTACHMENT I  
INSTRUMENTATION LIST

NOTES

1. Primary sensors.
2. Temperature readout device calibration equipment (resistance boxes for RTD bridges).
3. Test Equipment used for the in-situ calibration checks.
4. Calibration checks.
5. Some instrumentation was tested specifically for sensor sensitivity and readout repeatability, whereas others were not. For the latter case manufacturer's data was used.
6. Symbols defined for ISG formula (see Attachment IV and Refs. 5.5. and 5.6).



ATTACHMENT II  
INSTRUMENTATION SCHEMATIC

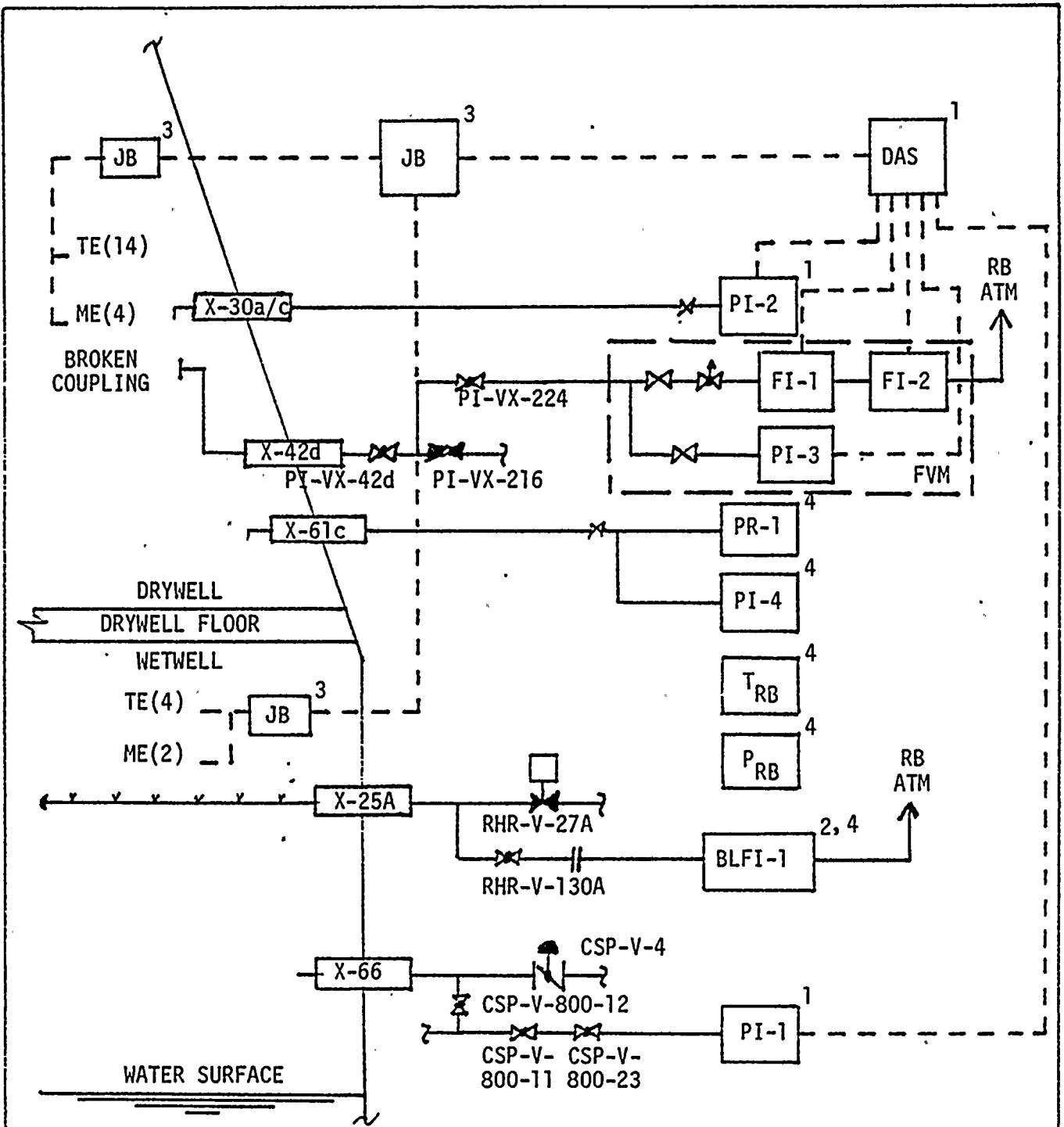

NOTES:

1. Part of ILRMS Cabinet
2. Only used during 5# and 1.5# BLRTS utilizing the fluid discharge method
3. Permanently installed
4. Data manually recorded

Figure II. 1 - Instrumentation Schematic

ATTACHMENT III  
INSTRUMENTATION (TEMPERATURE SENSOR) LOCATIONS

Table III.1  
Dry-Bulb and Dew Cell Information

<u>Instrument Type</u>	<u>Instrument Number</u>	<u>Elevation (Ft)</u>	<u>Azimuth<sup>1</sup> (Degrees)</u>	<u>Sensor Subvolume Number</u>	<u>Volume Fraction</u>
Drybulb	TE-1	572	90	4	0.0265377
	TE-2	550	240	3	0.0401997
	TE-3	525	5	2	0.0398009
	TE-4	505	120	1	0.0562705
	TE-5	550	120	3	0.0401997
	TE-6	505	0	1	0.0562705
	TE-7	525	75	2	0.0398009
	TE-8	525	235	2	0.0398009
	TE-9	525	180	2	0.0398009
	TE-10	550	0	3	0.0401997
	TE-11	572	270	4	0.0265377
	TE-12	525	125	2	0.0398009
	TE-13	525	315	2	0.0398009
	TE-14	505	240	1	0.0562705
	TE-15	485	270	5	0.104677
	TE-16	485	195	5	0.104677
	TE-17	485	0	5	0.104677
	TE-18	485	90	5	0.104677
Dewcell	ME-1	525	125	2	0.119403
	ME-2	550	90	3	0.173674
	ME-3	505	240	1	0.168811
	ME-4	525	5	2	0.119403
	ME-5	485	270	5	0.209354
	ME-6	485	90	5	0.209354

NOTE: Assumed to be equally spaced when Sensor Volume Fraction calculated.



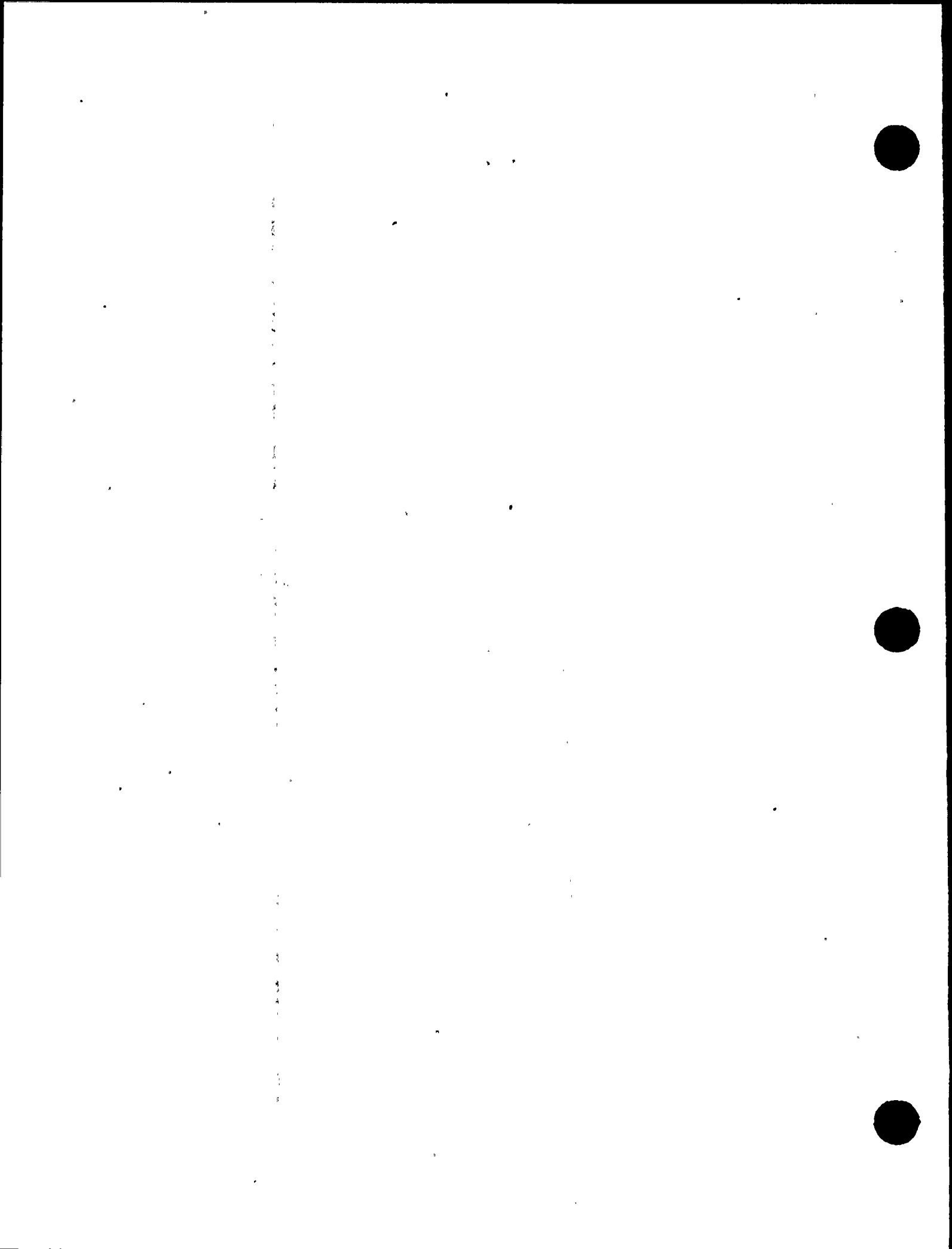

ATTACHMENT III  
INSTRUMENTATION (TEMPERATURE SENSOR) LOCATIONS

Table III.2  
Volume of Containment Subvolumes

Subvolume #	Volume Ft <sup>3</sup>
1	57,909
2	81,920
3	41,370
4	18,207
5	<u>143,634</u>
Total	343,040



ATTACHMENT III  
INSTRUMENTATION (TEMPERATURE SENSOR) LOCATIONS

SUBVOLUMES

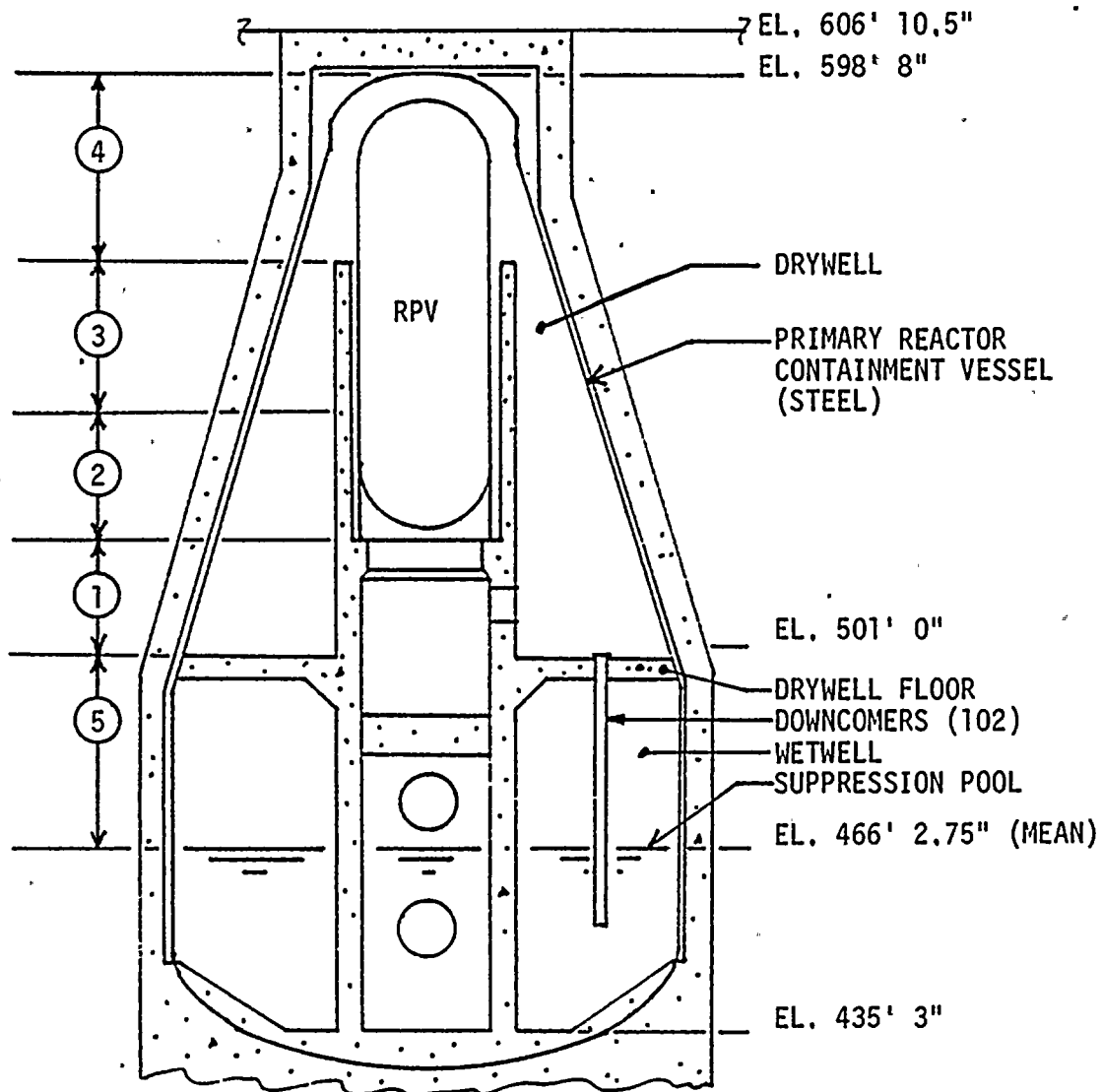

FIGURE III.1  
Primary Reactor Containment Section  
View Showing Subvolumes



ATTACHMENT IV  
ERROR ANALYSIS

A. LLRT

Selected LLRT results were analyzed to enable their summation with the PCILRT and LRVT results. These Type B and C-tested penetrations were the ones tabulated in Table 5. The analysis was performed in accordance with Reference 5.5, giving the pertinent data and calculated results tabulated in Table IV.1.

B. PCILRT

The analysis was performed in accordance with References 5.5 and 5.6. The instrument parameters were taken from Table I.1. Table IV.2 lists the results. Since the formulas used for the "ISG" (Instrument Selection Guide) are standard error analysis formulas they were used exactly as given in the references, even though the intent of the references authors was to present a method that could be used solely for instrumentation selection.

C. LRVT

The same instrumentation was used for the LRVT as was used for the PCILRT; therefore, the PCILRT analysis, shown in Table IV.2, applies linearly by compensating for time differences.

D. BLRT

The record method for this test was the Drywell Pressure Decay Method, using the same instrumentation and analysis technique as for B and C above. Since the number of sensors changed, a conservative sample error analysis is listed in Table IV.3 for the 1.5# BLRT.

No error analysis was performed for the Fluid Discharge method. Since the readout for the flow measurement device had a minimum resolution of one SCFM that number could be used.

ATTACHMENT IV  
ERROR ANALYSIS

Table IV.1  
LLRT Values to be Added to PCILRT & LRVT Results<sup>1</sup>

Pen	Valve	Date	P <sub>1</sub> (PSIA)	P <sub>2</sub> (PSIA)	T <sub>1</sub> (°R)	T <sub>2</sub> (°R)	V (FT <sup>3</sup> )	.LR (SCFH)	δ LR (SCFH)	LR (SCCM)	δ LR (SCCM)
8	LPCS-V-6	10-18-83	50.30	50.20	538.99	539.02	4.95	0.1018	0.09563	48.04	45.13
22	MS-V-16/19	3-26-84	50.20	50.09	536.14	536.17	0.5539	0.01255	0.01077	5.92	5.083
42d <sup>2</sup>	PI-VX-42d/216	2-16-84	49.70	49.65	538.33	538.51	0.8516	0.011436	0.01639	5.40	7.735
53	CSP-V-800-2 & 24	3-27-84	49.75	49.60	535.57	535.48	0.8478	0.0241	0.01645	11.41	7.762
	CSP-V-96 & 97	3-27-84	50.00	49.90	536.07	536.32	0.8828	0.0218	0.01714	10.33	8.089
66	CSP-V-11 & 23	3-16-84	50.40	49.10	533.27	533.57	0.8681	0.2328	0.01695	43.97	8.000

1. Reference 5.5. used as analysis basis.
2. Added to LRVT Results only.

TABLE IV. 2  
ILRT INSTRUMENT SELECTION GUIDE

TOTAL CONTAINMENT PRESSURE = 49.552  
CONTAINMENT TEMPERATURE (F) = 82.838  
CONTAINMENT DEWPOINT (F) = 78.066  
TEST DURATION (HRS) = 24.0  
NUMBER OF PRESSURE SENSORS = 2  
SENSOR ERROR (% OF FULL RANGE) = 0.001  
RANGE (PSIA) = 100.  
PRESSURE MEASUREMENT ERROR (% OF FULL RANGE) = 0.0005  
NUMBER OF DEWCELLS = 6  
DEWCELL SENSITIVITY ERROR(F) = 0.5  
DEWCELL SYSTEM ERROR = 0.01  
NUMBER OF RTD = 18  
RTD SENSITIVITY ERROR (F) = 0.036  
RTD SYSTEM ERROR (F) = 0.01

ERROR IN PRESSURE MEASUREMENT(PSI) = .0007  
ERROR IN DEWCELL PRESSURE (PSI) = .0032  
ERROR IN RTD MEASUREMENT (F) = .0088

\*\*\*\*\* ISG (%/DAY) = .0096 \*\*\*\*\*



TABLE IV.3 BLRT INSTRUMENTATION  
INSTRUMENT SELECTION GUIDE

TOTAL CONTAINMENT PRESSURE = 16.060  
CONTAINMENT TEMPERATURE (F) = 94.097  
CONTAINMENT DEWPOINT (F) = 74.600  
TEST DURATION (HRS) = 4.00  
NUMBER OF PRESSURE SENSORS = 1  
SENSOR ERROR (% OF FULL RANGE) = 0.001  
RANGE (PSIA) = 100.  
PRESSURE MEASUREMENT ERROR (% OF FULL RANGE) = 0.0005  
NUMBER OF DEWCELLS = 4  
DEWCELL SENSITIVITY ERROR(F) = 0.5  
DEWCELL SYSTEM ERROR = 0.01  
NUMBER OF RTD = 14  
RTD SENSITIVITY ERROR (F) = 0.036  
RTD SYSTEM ERROR (F) = 0.01

ERROR IN PRESSURE MEASUREMENT(PSI) = .0010  
ERROR IN DEWCELL PRESSURE (PSI) = .0035  
ERROR IN RTD MEASUREMENT (F) = .0100

\*\*\*\*\* ISG (%/DAY) = .1954 \*\*\*\*\*

ATTACHMENT V  
LEAKAGE RATE CALCULATIONS

A. PRESSURE DECAY ANALYSIS METHODS

There are several methods available for analysis of containment integrated leak rate data. The most commonly used methods are:

1. Mass point analysis
2. Total time analysis
3. Point to point analysis

A computer program was developed for the purpose of computing the containment leakage rate by all three methods (Ref. 5.12).

The mass point method consists of calculating the mass of air in the containment from the volume averaged temperature, dewpoint and pressure data by application of the perfect gas law. The test data consists of a time series of independent values of air mass. Assuming the leak rate is constant with time, the data lends itself to analysis by the method of linear regression. The slope of the regression line represents the rate of change of air mass with time or leak rate. Because of its independent nature, any error in a data set does not materially affect the test results. This is the most accurate method of analysis and is recommended in References 5.5 and 5.6.

The total time method is based on comparing the most recent data with the data taken at the start of the test. Thus each successive calculation is based on a longer time period. The leak rate in percent per day is determined by applying linear regression analysis to the leakage rate calculated at each time point (1).

The point to point method is similar to the total time method except that the leakage rate at each time point is determined using the most recent data and the data immediately preceding. The leakage rate is determined for each data time interval and the overall leak rate is obtained by application of linear regression to the leakage rate at each time point.

This section presents the theoretical basis, justification and derivations of formulae used in the computer program. The WPPSS ILRT program can calculate the leakage rate by all three methods.

- (1) This is one of the methods approved by Reference 5.3 and is the one chosen by WPPSS as the primary reporting method.

1. Mass Point Method

The individual temperature and dewpoint readings are volume averaged according to a volume fraction assigned to each sensor. This averaging process is the same for all three methods of calculating leak rate.

The average containment drybulb temperature,  $T_{aj}$ , at time  $j$  is:

$$T_{aj} = \sum_{i=1}^n f_i T_{i,j}$$

where:

$f_i$  = Volume fraction of containment associated  
drybulb sensor  $i$

$T_{i,j}$  = Drybulb sensor  $i$   
reading at time  $j$

The average dewpoint temperature at time  $j$ ,  $T_{DP,j}$  is:

$$T_{DP,j} = \sum f_i T_{dp i,j}$$

where:

$f_i$  = Volume fraction of containment associated  
drybulb sensor  $i$

$T_{dp i,j}$  = Dewpoint reading of sensor  $i$  at time  $j$

If two pressure sensors are used, the averaged pressure is simply:

$$P_{Total} = 0.5 (P_A + P_B)$$

where:

$P_A$  and  $P_B$  are the two pressure readings

The mass of air is calculated from the ideal gas law.

$$(1) PV = NRT$$

where:

$P$  = air pressure, psia

$V$  = volume,  $ft^3$

$N$  = lb moles of air

$R$  = ideal gas law constant  
 $\frac{10.731 \text{ Psi} - ft^3}{lb \text{ mole} - ^\circ R}$

$T$  = absolute containment temperature ( $^\circ R$ )

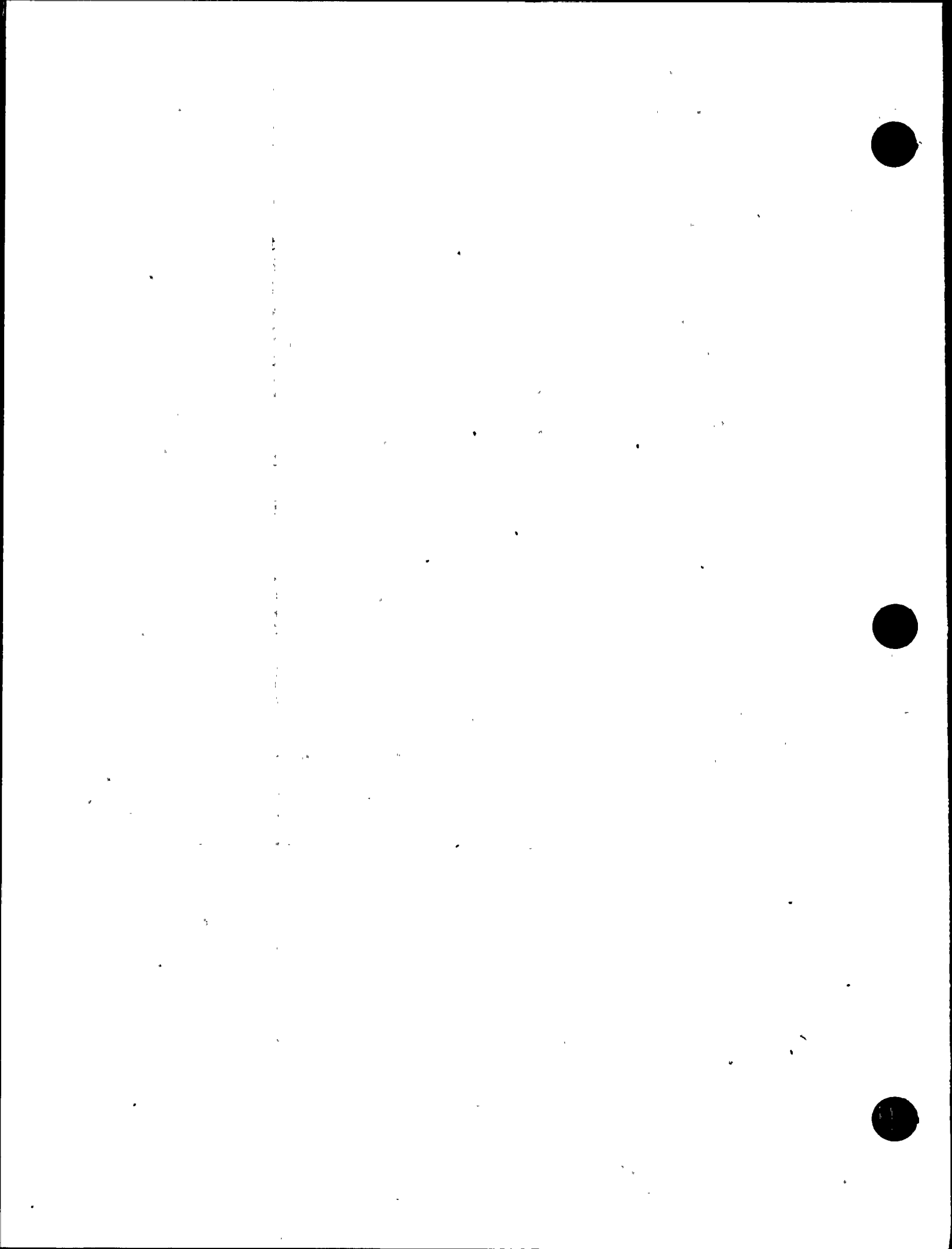

Rearranging equation (1) gives:

$$(2) \quad N = \frac{PV}{RT}$$

The mass of air is simply the product of the number of lb moles and the molecular weight of air.

$$(3) \quad W = N (MW) = \frac{PV}{RT} (MW)$$

The molecular weight of air is 28.96  $\frac{\text{lb mass}}{\text{lb mole}}$

Therefore the weight of air at any time is:

$$(4) \quad W = \frac{PV (28.96)}{10.731 (T)}$$

It is important to note that P is the partial pressure of air not the total containment pressure as measured by the pressure sensors. The partial pressure of air is the total pressure minus the partial pressure of water vapor,  $P_{H_2O}$ .

$$P_{\text{air}} = P_{\text{Total}} - P_{H_2O}$$

One of the widely used correlations for vapor pressure is the Antoine correlation (Ref. 5.8) which is of the form:

$$\ln P = A - \frac{B}{T-C}$$

If  $C = 0$  this equation reverts to the Clapeyron equation (Ref. 5.7). Rather than use published constants which cover a wide temperature range for water vapor in the Antoine equation, constants were determined to more accurately cover a narrow temperature range by utilizing data from Keenan & Keyes (Ref. 5.9). Two sets of constants were generated, one set for dew points less than 100°F and the second set for the temperature range of 100 to 120°F. The correlations agree with data in Keenan & Keyes to within 0.0001 psia. This functional form gives more accurate results than linear interpolation between the data points.

The correlations developed and used in the ILRTA computer program (Ref. 5.12) are:

$$\ln P = 14.940404 - \frac{4144.18422}{T-34.5}$$

for  $60 < T < 100$

where T is in °K

and

$$\ln P = 14.643483 - \frac{3984.9582}{T-39.75}$$

for  $100 < T < 120$

where T is in °K

P is in psia

With the equations listed above, the mass of air can be calculated for each data set. Next, a linear regression of the air mass is performed to obtain an estimate of the leak rate. This is done to provide a criteria for obtaining the best fit of the data, assuming a linear relation between air mass and time (i.e. a constant leak rate).

Linear regression or least mean square curve fit is given by:

$$\bar{W} = A + Bt$$

Where the slope, B, and intercept, A, are given by:

$$B = \frac{n(\sum t_i W_i) - (\sum W_i) (\sum t_i)}{n (\sum t_i^2) - (\sum t_i)^2}$$

and

$$A = \frac{(\sum W_i) (\sum t_i^2) - (\sum t_i W_i) (\sum t_i)}{n (\sum t_i^2) - (\sum t_i)^2}$$

Each  $t_i$  is the elapsed time between a clock time at which the initial reading is taken and the clock time at which the  $i$ th reading is taken. Thus  $t_1 = 0$  for all the test durations and  $t_2$  is the elapsed time before the next reading and so on. In most test applications the time intervals between collected data sets will be essentially constant, but the equations for the slope, B, and intercept, A, do not impose this as a limitation.

The leakage rate for nuclear power plant containments is expressed as the ratio of the rate of change of air mass to the air mass in the containment at the beginning of the test. Since  $t_i$  is expressed in hours and percentage daily leakage rates are desired, the mass point leakage rate is expressed as a positive number, as:

$$L_{am} = - 2400 B/A$$

It should be noted that A, the best estimate of the initial air mass, not  $W_0$  is used as the denominator of  $L_{am}$ . The units of  $L_{am}$  are percent per day.

The uncertainty in the estimated value of  $L_{am}$  is assessed in terms of the standard deviations of A and B and their covariance followed by the computation of the 95th confidence level for  $L_{am}$ .

The estimate of the common standard deviation of the air mass with respect to the regression line is given by:

$$S = \left[ \frac{\sum (W - \bar{W})^2}{n - 2} \right]^{1/2}$$

where:  $W_i =$  measured air mass at time  $t_i$

$\bar{W} =$  estimated air mass at time  $t_i$

(i.e.  $\bar{W} = A + Bt_i$ )

The standard deviations of the slope and intercept are:

$$S_B = Kn^{1/2}$$

$$S_A = K(\sum t_i^2)^{1/2}$$

where:

$$K = \frac{S}{[\eta(\sum t_i^2) - (\sum t_i)^2]^{1/2}}$$

and the covariance of the slope and intercept is:

$$S_{BA} = K^2 (-\sum t_i)$$

The above equations are presented in Reference 5.6 and can be found in most elementary statistical texts.

The exact upper one-sided limit of a 95 percent confidence level for the leakage rate is given by:

$$UCL (L_{\text{exact}}) = - 2400 [b - (b^2 - ac)^{1/2}]/a$$

where:

$$a = A^2 - t_{.95}^2 S_A^2$$

$$b = AB - t_{.95}^2 S_{AB}$$

$$c = B^2 - t_{.95}^2 S_B^2$$

$t_{.95}$  is the 95th percentile of the "student's t distribution", which is tabulated in Reference 5.6 and most texts on statistics as a function of the number of degrees of freedom. The number of degrees of freedom is  $(n - 2)$  where  $n$  is the number of observations. If the number of degrees of freedom is equal to or greater than 5, the value of  $t_{.95}$  can be calculated from the following equation:

$$t_{.95} = 1.654 + \frac{1.576}{n-2} - \frac{2.4}{(n-2)^2} + \frac{57.6}{(n-2)^3}$$

The equations presented above for calculating the mass point leak rate and appropriate statistical treatment have been programmed into a flexible easy to use computer program.

## 2. Total Time Method

The mass point method of computing leak rate is the preferred method and is recommended by References 5.5 and 5.6. However, in the past, the total time and point to point leak rate analyses were used to calculate the containment leak rate and are the acceptable methods recognized by Reference 5.3, which is the basic document for this test. Therefore, these methods of computing leak rate were included in the computer program.

The equation for calculating the leak rate by the total time method is taken from Reference 5.2 The formula is:

$$LR_{ni} = \frac{2400}{H_i} \left[ 1 - \frac{T_o (P_i - P_{vi})}{T_i (P_o - P_{vo})} \right]$$

where:

$LR_{ni}$  = measured leak rate of time  $i$ , in weight percent per day

$H_i$  = Elapsed time in hours at time  $i$





- $T_0$  = Mean containment absolute temperature at start of test  
 $T_i$  = Mean containment absolute temperature at time  $i$   
 $P_0$  = Mean total pressure of containment atmosphere at start of test, psia  
 $P_i$  = Mean total pressure of containment atmosphere at time  $i$ , psia  
 $P_{v0}$  = Mean containment atmosphere water vapor pressure at start of test  
 $P_{vi}$  = Mean containment atmosphere water vapor pressure at time  $i$

The calculated leak rate is obtained by performing a linear regression of 3 or more sets of measured leak rate. The regression line is given by:

$$LR_C = A + Bt_i$$

The variance of the measured leak rate ( $LR_m$ ) from the calculated leak rate ( $LR_i$ ) is:

$$S = \left\{ \frac{[LR_{ni} - (A + Bt_i)]^2}{n-2} \right\}^{1/2}$$

where:

$n$  = the number of measured data sets

The 95 percent upper confidence limit of the leak rate is:

$$UCL = LR_C + \sigma T$$

where:

$T$  = Student T distribution for  $n-2$  degrees of freedom

$$\sigma = S \left[ 1 + \frac{1}{n} + \frac{\sum (t_p - \bar{t})^2}{\sum (t_i - \bar{t})^2} \right]^{1/2}$$

$t_p$  = Time after start of test or total elapsed time

$$\bar{t} = \frac{\sum t_i}{n}$$

The above equations have been included in the program.

### 3. Point to Point Method

The point to point method is essentially the same as the total time method, except rather than referencing the calculations to the values of pressure and temperature at the start of the test, the pressure and temperature at any time  $i$ , are referenced to time  $i - 1$ . Thus, the measured leak rate equation is:

$$LR_{mi} = \frac{2400}{h} \left[ 1 - \frac{T_1 (P_2 - P_{v2})}{T_2 (P_1 - P_{v1})} \right]$$

where:

$P_i$  = Mean absolute containment pressure, psia, at time  $i$

$T_i$  = Mean containment atmosphere absolute temperature at time  $i$

$h$  = time interval between time  $i$  and  $i - 1$

The regression line, variance and 95 percent upper confidence level are in the same manner for the total time method. The equations for the point to point method have been incorporated in the program.



B. CORRECTIONS TO THE PCILRT AND THE LRVT CALCULATED RESULTS

1. PCILRT (Refer to Tabel IV.1)

a. LLRT Correction

1)  $\Sigma LR = 48.04 + 5.92 + 11.41 + 10.33 + 43.97 = 119.67$  SCCM

2) Standard Deviation on (1):

$$[(45.13)^2 + (5.083)^2 + (7.762)^2 + (8.089)^2 + (8)^2]^{1/2} = 47.46 \text{ SCCM}$$

3)  $\therefore LR$  to add to PCILRT LR =  $119.67 + 47.46$   
= 167.13 SCCM

4) Conversion:

$$\text{Correction} = \frac{(167.13 \text{ cm}^3) (60) (24) \times 100 \times \left(\frac{14.696}{P}\right) \left(\frac{T + 459.69}{519.69}\right)}{\left(30.48 \frac{\text{cm}^3}{\text{ft}^3}\right) (142,500 + 200,540)}$$

where,  $P = 49.163$  psia  
 $T = 83.919^\circ\text{F}$

= 0.0007747 w/o/day

b. Wetwell (Suppression Pool) level change correction.

1) Level decreased 0.2 inches in 24 hours.

2) Suppression Pool surface area = 4495 Ft<sup>2</sup>.

3) Correction =

$$- \left(\frac{0.2}{12}\right) (4495) \times 100 = -0.02184 \text{ w/o/day}$$

c. Drywell sump level change correction

1) Level increased 9 inches in 24 hours (equivalent to 46.2 ft<sup>3</sup>).

2) Correction =  $\frac{46.2}{(142,500 + 200,540)} \times 100 = 0.01346$  w/o/day



2. LRVT (Refer to Table IV.1)

a.  $\Sigma LR = 119.67 + 5.40 = 125.07$  SCCM

b. Standard Deviation on (1) =  $[(47.46)^2 + (7.735)^2]^{1/2}$   
= 48.09 SCCM

c.  $\Delta LR$  to add to LRVT LR = 173.16 SCCM

d. Conversion:

$$\text{Correction} = \frac{(173.16)(60)(24)(100) \left( \frac{14.696}{49.681} \right) \left( \frac{85.414 + 459.69}{519.69} \right)}{(30.48)^3 (343,040)}$$
$$= 0.0007965 \text{ w/o/day}$$

C. LRVT CALCULATIONS

The superimposed leakage was 4.00 scfm. The average containment temperature and pressure were 85.414°F and 49.6808 psia. The total containment volume is 343,040 ft<sup>3</sup>. Therefore the superimposed leakage rate, L<sub>o</sub>, is:

$$L_o = 100\% \left[ \frac{4.00 \text{ scfm} \left( \frac{14.696 \text{ psia}}{49.6808 \text{ psia}} \right) \left( \frac{85.414 + 459.69R}{60 + 459.69R} \right)}{343,040 \text{ Ft}^3} \right] \left( 60 \frac{\text{min}}{\text{hr}} \right) \left( \frac{24 \text{ hr}}{\text{Day}} \right)$$

= 0.52098 weight percent per day

The following values are therefore used to demonstrate compliance with the acceptance criteria.

L<sub>o</sub> = 0.5210 weight percent per day

L<sub>am</sub> = 0.2110 weight percent per day (calculated)

L<sub>a</sub> = 0.5 weight percent per day

L<sub>c</sub> = 0.6274 weight percent per day (calculated)

Using these values in the acceptance criteria equation:

$$(L_o + L_{am} - .25 L_a) \leq L_c \leq (L_o + L_{am} + .25 L_a)$$

$$[0.5210 + .2110 - .25(.5)] \leq 0.6274 \leq [0.5210 + 0.2110 + .25(.5)]$$
$$0.6070 \leq 0.6274 \leq 0.8570$$

Incorporating the LRVT correction factor (This Attachment, Section B.2.d) produces:

$$0.6078 \text{ w/o/d} \leq 0.6282 \text{ w/o/d} \leq 0.8578 \text{ w/o/d}$$

D. CORRELATION OF BLRT RESULTS USING THE FLUID DISCHARGE METHOD WITH THE BLRT RESULTS USING THE DRYWELL PRESSURE DECAY METHOD

1. 5 PSID BLRT

a. Fluid discharge leakage rate = 17 SCFM.

b. Conversion:

$$\begin{aligned} LR &= \left[ \frac{(17)(60)(24)}{200,540} \right] \left( \frac{14.696}{14.409} \right) \left( \frac{76.64 + 459.69}{519.69} \right) (100) \\ &= (0.12207) (1.0199) (1.0320) (100) \\ &= 12.849 \text{ w/o/day} \end{aligned}$$

c. Comparison

1) Pressure Decay leakage rate = 8.01 w/o/day

2) Fluid Discharge leakage rate is 60.4% larger than the Pressure Decay leakage rate

2. 1.5 PSID BLRT

a. Fluid Discharge leakage rate  $\cong$  6 SCFM\*

b. Conversion:

$$\begin{aligned} LR &= \left[ \frac{(6)(60)(24)}{200,540} \right] \left( \frac{14.696}{14.485} \right) \left( \frac{76.70 + 459.69}{519.69} \right) (100) \\ &= (0.043084) (1.0146) (1.0321) (100) \\ &= 4.5116 \text{ w/o/day} \end{aligned}$$

c. Comparison

1) Pressure Decay leakage rate = 4.04 w/o/day

2) Fluid Discharge leakage rate is 11.7% larger than the Pressure Decay leakage rate

\* Flow instrument not calibrated below 10 SCFM



ATTACHMENT VI  
DATA SUMMARIES

Table of Contents

1. Temperature Stabilization
2. PCILRT Averaged Measured Data
3. PCILRT Corrected Data Summary
4. PCILRT Total Time Leakage Rate
5. PCILRT Mass Point Leakage Rate
6. LRVT Averaged Measured Data
7. LRVT Corrected Data Summary
8. LRVT Total Time Leakage Rate
9. LRVT Mass Point Leakage Rate
10. 25# BLRT Averaged Measured Data, Drywell Pressure Decay
11. 25# BLRT Corrected Data Summary, Drywell Pressure Decay
12. 25# BLRT Total Time Leakage Rate, Drywell Pressure Decay
13. 25# BLRT Mass Point Leakage Rate, Drywell Pressure Decay
14. 15# BLRT Average Measured Data, Drywell Pressure Decay
15. 15# BLRT Corrected Data Summary, Drywell Pressure Decay
16. 15# BLRT Total Time Leakage Rate, Drywell Pressure Decay
17. 15# BLRT Mass Point Leakage Rate, Drywell Pressure Decay
18. 5# BLRT Average Measured Data, Drywell Pressure Decay
19. 5# BLRT Corrected Data Summary, Drywell Pressure Decay
20. 5# BLRT Total Time Leakage Rate, Drywell Pressure Decay
21. 5# BLRT Mass Point Leakage Rate, Drywell Pressure Decay

ATTACHMENT VI  
DATA SUMMARIES

Table of Contents (Cont.)

22. 1.5# BLRT Average Measured Data, Drywell Pressure Decay
23. 1.5# BLRT Corrected Data Summary, Drywell Pressure Decay
24. 1.5# BLRT Total Time Leakage Rate, Drywell Pressure Decay
25. 1.5# BLRT Mass Point Leakage Rate, Drywell Pressure Decay

TABLE VI.1

WNP-2 ILRT RESTART AT 2159 HR  
TEST STARTED AT 2159 ON 2/10/84  
TEMPERATURE STABILIZATION

DATA SET #	TIME (HR)	TEMP R	DELTA T 4-HR	DELTA T 1-HR	DELTA
1	21.98	541.8779			
5	22.98	541.9809			
9	23.98	542.1002			
13	0.98	542.2324			
17	1.98	542.3373	0.1149	0.1049	0.0099
21	2.98	542.4725	0.1229	0.1352	-0.0123
25	3.98	542.5964	0.1240	0.1239	0.0001
29	4.98	542.6994	0.1167	0.1030	0.0138
33	5.98	542.8137	0.1191	0.1143	0.0048



TABLE VI. 2  
 WNP-2 ILRT  
 TEST STARTED AT 329 ON 2/11/84  
 AVERAGED MEASURED DATA

DATA SET #	TIME (HR)	TEMP (F)	DEWPT (F)	PRESSURE (PSI)
1	329	82.838	74.593	49.552
2	344	82.871	74.736	49.553
3	359	82.906	74.666	49.555
4	414	82.922	74.802	49.557
5	429	82.951	74.834	49.558
6	444	82.978	74.835	49.560
7	459	83.009	74.959	49.561
8	514	83.040	75.011	49.563
9	529	83.070	74.971	49.564
10	544	83.092	75.110	49.566
11	559	83.124	75.048	49.568
12	614	83.145	75.068	49.569
13	629	83.169	75.239	49.571
14	644	83.203	75.204	49.573
15	659	83.217	75.257	49.575
16	714	83.252	75.252	49.577
17	729	83.278	75.333	49.579
18	744	83.306	75.520	49.580
19	759	83.336	75.557	49.582
20	814	83.364	75.558	49.584
21	829	83.385	75.734	49.586
22	844	83.409	75.774	49.588
23	859	83.437	75.809	49.589
24	914	83.488	75.841	49.591
25	929	83.506	75.724	49.593
26	944	83.513	75.967	49.593
27	959	83.531	75.936	49.595
28	1014	83.567	75.909	49.596
29	1029	83.591	75.958	49.598
30	1044	83.601	75.997	49.597
31	1059	83.618	76.035	49.597
32	1114	83.622	75.983	49.596
33	1129	83.635	76.064	49.595
34	1144	83.632	75.836	49.595
35	1159	83.615	75.808	49.595
36	1214	83.635	75.745	49.593
37	1229	83.627	75.676	49.593
38	1244	83.633	75.555	49.591
39	1259	83.636	75.678	49.591
40	1314	83.650	75.665	49.591
41	1329	83.669	75.683	49.591
42	1344	83.680	75.817	49.592
43	1359	83.706	75.886	49.593
44	1414	83.727	75.942	49.594



TABLE VI. 2 (CONT.)

DATA SET #	TIME (HR)	TEMP (F)	DEWPT (F)	PRESSURE (PSI)
45	1429	83.754	76.061	49.595
46	1444	83.761	76.089	49.596
47	1459	83.777	76.022	49.598
48	1514	83.806	76.192	49.599
49	1529	83.831	76.068	49.601
50	1544	83.846	76.272	49.603
51	1559	83.871	76.245	49.604
52	1614	83.901	76.255	49.606
53	1629	83.919	76.368	49.608
54	1644	83.944	76.347	49.609
55	1659	83.970	76.441	49.611
56	1714	83.992	76.436	49.612
57	1729	84.010	76.478	49.614
58	1744	84.030	76.562	49.615
59	1759	84.062	76.433	49.617
60	1814	84.078	76.614	49.619
61	1829	84.111	76.631	49.620
62	1844	84.129	76.684	49.622
63	1859	84.153	76.843	49.624
64	1914	84.173	76.746	49.626
65	1929	84.204	76.813	49.628
66	1944	84.235	76.813	49.629
67	1959	84.262	76.917	49.631
68	2014	84.298	76.999	49.633
69	2029	84.319	77.017	49.635
70	2044	84.343	77.070	49.636
71	2059	84.376	77.101	49.638
72	2114	84.402	77.230	49.640
73	2129	84.423	77.146	49.642
74	2144	84.452	77.234	49.644
75	2159	84.475	77.240	49.645
76	2214	84.488	77.332	49.647
77	2229	84.526	77.346	49.649
78	2244	84.549	77.392	49.650
79	2259	84.579	77.370	49.652
80	2314	84.595	77.397	49.654
81	2329	84.633	77.535	49.656
82	2344	84.650	77.568	49.658
83	2359	84.693	77.557	49.660
84	14	84.712	77.661	49.662
85	29	84.732	77.592	49.664
86	44	84.743	77.607	49.665
87	59	84.765	77.702	49.666
88	114	84.781	77.719	49.668
89	129	84.810	77.893	49.669
90	144	84.842	77.848	49.670
91	159	84.870	77.921	49.672
92	214	84.887	77.959	49.673
93	229	84.910	77.988	49.675
94	244	84.942	77.958	49.677
95	259	84.964	78.047	49.678
96	314	84.982	78.049	49.679
97	329	85.012	78.066	49.681





TABLE VI. 3

WNP-2 ILRT  
TEST STARTED AT 329 ON 2/11/84  
CORRECTED DATA SUMMARY

DATA SET #	TIME (HRS)	TEMP (F)	PRESSURE AIR (PSI)	AIR MASS (LB)	PRESSURE TOTAL (PSI)
1	329	82.838	49.1275	83831.18	49.5516
2	344	82.871	49.1269	83825.09	49.5531
3	359	82.906	49.1299	83824.79	49.5551
4	414	82.922	49.1295	83821.68	49.5566
5	429	82.951	49.1300	83818.03	49.5576
6	444	82.978	49.1320	83817.18	49.5596
7	459	83.009	49.1312	83811.06	49.5606
8	514	83.040	49.1325	83808.40	49.5626
9	529	83.070	49.1340	83806.50	49.5636
10	544	83.092	49.1340	83803.10	49.5656
11	559	83.124	49.1369	83803.16	49.5676
12	614	83.145	49.1381	83801.92	49.5691
13	629	83.169	49.1371	83796.56	49.5705
14	644	83.203	49.1396	83795.47	49.5725
15	659	83.217	49.1409	83795.40	49.5745
16	714	83.252	49.1429	83793.53	49.5765
17	729	83.278	49.1438	83790.95	49.5785
18	744	83.306	49.1426	83784.62	49.5800
19	759	83.336	49.1445	83783.19	49.5825
20	814	83.364	49.1459	83781.47	49.5840
21	829	83.385	49.1454	83777.20	49.5860
22	844	83.409	49.1473	83776.77	49.5885
23	859	83.437	49.1478	83773.25	49.5895
24	914	83.488	49.1488	83767.19	49.5910
25	929	83.506	49.1525	83770.63	49.5929
26	944	83.513	49.1494	83764.27	49.5934
27	959	83.531	49.1514	83764.88	49.5949
28	1014	83.567	49.1527	83761.76	49.5959
29	1029	83.591	49.1540	83760.20	49.5979
30	1044	83.601	49.1525	83756.04	49.5969
31	1059	83.618	49.1519	83752.42	49.5969
32	1114	83.622	49.1521	83752.16	49.5964
33	1129	83.635	49.1500	83746.56	49.5954
34	1144	83.632	49.1528	83751.78	49.5949
35	1159	83.615	49.1532	83755.09	49.5949
36	1214	83.635	49.1522	83750.30	49.5929
37	1229	83.627	49.1532	83753.15	49.5929
38	1244	83.633	49.1534	83752.75	49.5914
39	1259	83.636	49.1512	83748.49	49.5910
40	1314	83.650	49.1514	83746.62	49.5910
41	1329	83.669	49.1511	83743.28	49.5910
42	1344	83.680	49.1501	83739.79	49.5919
43	1359	83.706	49.1501	83735.78	49.5929
44	1414	83.727	49.1503	83732.85	49.5939
45	1429	83.754	49.1500	83728.23	49.5954
46	1444	83.761	49.1506	83728.11	49.5964
47	1459	83.777	49.1536	83730.76	49.5984
48	1514	83.806	49.1521	83723.78	49.5994
49	1529	83.831	49.1559	83719.43	49.6014

TABLE VI. 3 (CONT. )

DATA SET #	TIME (HRS)	TEMP (F)	PRESSURE AIR (PSI)	AIR MASS (LB)	PRESSURE TOTAL (PSI)
50	1544	83.846	49.1548	83722.32	49.6034
51	1559	83.871	49.1562	83720.75	49.6044
52	1614	83.901	49.1581	83719.26	49.6064
53	1629	83.919	49.1579	83716.20	49.6079
54	1644	83.944	49.1597	83715.46	49.6094
55	1659	83.970	49.1603	83712.46	49.6114
56	1714	83.992	49.1614	83710.89	49.6124
57	1729	84.010	49.1622	83709.55	49.6139
58	1744	84.030	49.1624	83706.90	49.6153
59	1759	84.062	49.1664	83708.69	49.6173
60	1814	84.078	49.1656	83704.92	49.6193
61	1829	84.111	49.1664	83701.12	49.6203
62	1844	84.129	49.1676	83700.45	49.6223
63	1859	84.153	49.1672	83696.00	49.6243
64	1914	84.173	49.1706	83698.83	49.6263
65	1929	84.204	49.1711	83694.87	49.6278
66	1944	84.235	49.1726	83692.61	49.6293
67	1959	84.262	49.1730	83689.14	49.6313
68	2014	84.298	49.1738	83684.99	49.6333
69	2029	84.319	49.1755	83684.68	49.6353
70	2044	84.343	49.1757	83681.30	49.6363
71	2059	84.376	49.1772	83678.64	49.6382
72	2114	84.402	49.1772	83674.80	49.6402
73	2129	84.423	49.1805	83677.12	49.6422
74	2144	84.452	49.1806	83672.99	49.6437
75	2159	84.475	49.1820	83671.79	49.6452
76	2214	84.488	49.1826	83670.72	49.6472
77	2229	84.526	49.1839	83667.08	49.6487
78	2244	84.549	49.1846	83664.78	49.6502
79	2259	84.579	49.1870	83664.26	49.6522
80	2314	84.595	49.1886	83664.49	49.6542
81	2329	84.633	49.1884	83658.38	49.6562
82	2344	84.650	49.1894	83657.46	49.6577
83	2359	84.693	49.1916	83654.55	49.6597
84	14	84.712	49.1920	83652.36	49.6617
85	29	84.732	49.1951	83654.50	49.6637
86	44	84.743	49.1958	83653.99	49.6647
87	59	84.765	49.1959	83650.78	49.6662
88	114	84.781	49.1976	83651.22	49.6682
89	129	84.810	49.1959	83643.87	49.6692
90	144	84.842	49.1971	83640.92	49.6697
91	159	84.870	49.1979	83638.08	49.6716
92	214	84.887	49.1988	83636.99	49.6731
93	229	84.910	49.1999	83635.27	49.6746
94	244	84.942	49.2023	83634.43	49.6766
95	259	84.964	49.2019	83630.39	49.6776
96	314	84.992	49.2029	83629.26	49.6786
97	329	85.012	49.2051	83628.49	49.6811



TABLE VI. 4  
WNP-2 ILRT  
TEST STARTED AT 329 ON 2/11/84  
TOTAL TIME LEAK RATE  
ELAPSED TIME = 24.00

DATA SET #	ELAPSED TIME (HR)	TEMP AVG (F)	PRESSURE (PSIA)	LEAK RATE	
				MEASURED	CALCULATED
2	0.25	82.8714	49.1269	0.69740	0.34025
3	0.50	82.9064	49.1299	0.36600	0.33889
4	0.75	82.9217	49.1295	0.36262	0.33753
5	1.00	82.9513	49.1300	0.37638	0.33617
6	1.25	82.9782	49.1320	0.32071	0.33481
7	1.50	83.0094	49.1312	0.38410	0.33345
8	1.75	83.0404	49.1325	0.37268	0.33209
9	2.00	83.0701	49.1340	0.35323	0.33073
10	2.25	83.0922	49.1340	0.35730	0.32937
11	2.50	83.1237	49.1369	0.32087	0.32801
12	2.75	83.1451	49.1381	0.30465	0.32665
13	3.00	83.1686	49.1371	0.33040	0.32529
14	3.25	83.2033	49.1396	0.31459	0.32393
15	3.50	83.2174	49.1409	0.29262	0.32257
16	3.75	83.2524	49.1429	0.28742	0.32121
17	4.00	83.2783	49.1438	0.28791	0.31985
18	4.25	83.3059	49.1426	0.31365	0.31849
19	4.50	83.3363	49.1445	0.30532	0.31713
20	4.75	83.3638	49.1459	0.29963	0.31577
21	5.00	83.3851	49.1454	0.30908	0.31441
22	5.25	83.4091	49.1473	0.29671	0.31305
23	5.50	83.4372	49.1478	0.30155	0.31168
24	5.75	83.4878	49.1488	0.31859	0.31032
25	6.00	83.5062	49.1525	0.28892	0.30896
26	6.25	83.5133	49.1494	0.30647	0.30760
27	6.50	83.5311	49.1514	0.29203	0.30624
28	6.75	83.5666	49.1527	0.29441	0.30488
29	7.00	83.5909	49.1540	0.29029	0.30352
30	7.25	83.6006	49.1525	0.29671	0.30216
31	7.50	83.6178	49.1519	0.30065	0.30080
32	7.75	83.6223	49.1521	0.29188	0.29944
33	8.00	83.6345	49.1500	0.30280	0.29808
34	8.25	83.6323	49.1528	0.27551	0.29672
35	8.50	83.6153	49.1532	0.25627	0.29536
36	8.75	83.6345	49.1522	0.26463	0.29400
37	9.00	83.6272	49.1532	0.24821	0.29264
38	9.25	83.6329	49.1534	0.24274	0.29128
39	9.50	83.6336	49.1512	0.24918	0.28992
40	9.75	83.6498	49.1514	0.24827	0.28856
41	10.00	83.6687	49.1511	0.25164	0.28720
42	10.25	83.6800	49.1501	0.25526	0.28584
43	10.50	83.7058	49.1501	0.26010	0.28448
44	10.75	83.7268	49.1503	0.26185	0.28312
45	11.00	83.7539	49.1500	0.26793	0.28176
46	11.25	83.7612	49.1506	0.26228	0.28040
47	11.50	83.7770	49.1536	0.24998	0.27904



TABLE VI. 4 (CONT.)

DATA SET #	ELAPSED TIME (HR)	TEMP AVG (F)	PRESSURE (PSIA)	LEAK RATE	
				MEASURED	CALCULATED
48	11.75	83.8055	49.1521	0.26168	0.27768
49	12.00	83.2308	49.1559	0.24990	0.27632
50	12.25	83.8456	49.1548	0.25440	0.27496
51	12.50	83.8713	49.1562	0.25291	0.27360
52	12.75	83.9014	49.1581	0.25130	0.27224
53	13.00	83.9191	49.1579	0.25319	0.27088
54	13.25	83.9441	49.1597	0.25002	0.26952
55	13.50	83.9701	49.1603	0.25175	0.26816
56	13.75	83.9921	49.1614	0.25044	0.26680
57	14.00	84.0105	49.1622	0.24872	0.26544
58	14.25	84.0298	49.1624	0.24969	0.26408
59	14.50	84.0617	49.1664	0.24184	0.26272
60	14.75	84.0782	49.1656	0.24507	0.26136
61	15.00	84.1112	49.1664	0.24824	0.26000
62	15.25	84.1288	49.1676	0.24542	0.25864
63	15.50	84.1534	49.1672	0.24969	0.25728
64	15.75	84.1727	49.1706	0.24056	0.25592
65	16.00	84.2039	49.1711	0.24391	0.25456
66	16.25	84.2350	49.1726	0.24412	0.25320
67	16.50	84.2623	49.1730	0.24645	0.25184
68	16.75	84.2975	49.1738	0.24986	0.25048
69	17.00	84.3188	49.1755	0.24672	0.24912
70	17.25	84.3428	49.1757	0.24875	0.24776
71	17.50	84.3764	49.1772	0.24954	0.24640
72	17.75	84.4017	49.1772	0.25221	0.24504
73	18.00	84.4230	49.1805	0.24503	0.24368
74	18.25	84.4516	49.1806	0.24815	0.24232
75	18.50	84.4749	49.1820	0.24666	0.24096
76	18.75	84.4884	49.1826	0.24500	0.23959
77	19.00	84.5257	49.1839	0.24726	0.23823
78	19.25	84.5494	49.1846	0.24747	0.23687
79	19.50	84.5787	49.1870	0.24505	0.23551
80	19.75	84.5948	49.1886	0.24163	0.23415
81	20.00	84.6330	49.1884	0.24735	0.23279
82	20.25	84.6501	49.1894	0.24560	0.23143
83	20.50	84.6931	49.1916	0.24667	0.23007
84	20.75	84.7115	49.1920	0.24671	0.22871
85	21.00	84.7315	49.1951	0.24086	0.22735
86	21.25	84.7434	49.1958	0.23871	0.22599
87	21.50	84.7646	49.1959	0.24022	0.22463
88	21.75	84.7810	49.1976	0.23687	0.22327
89	22.00	84.8099	49.1959	0.24375	0.22191
90	22.25	84.8424	49.1971	0.24480	0.22055
91	22.50	84.8698	49.1979	0.24570	0.21919
92	22.75	84.8869	49.1988	0.24437	0.21783
93	23.00	84.9098	49.1999	0.24365	0.21647
94	23.25	84.9424	49.2023	0.24226	0.21511
95	23.50	84.9645	49.2019	0.24461	0.21375
96	23.75	84.9819	49.2029	0.24327	0.21239
97	24.00	85.0118	49.2051	0.24178	0.21103

TOTAL TIME LEAK RATE = 0.211030

95% UPPER CONFIDENCE LIMIT LEAK RATE = 0.2934

MAXIMUM ALLOWABLE LEAK RATE = 0.375

TABLE VI. 5

WNP-2 ILRT  
 TEST STARTED AT 329 ON 2/11/84  
 MASS POINT LEAK RATE  
 ELAPSED TIME = 24.00

DATA SET #	ELAPSED TIME (HR)	TEMP AVG (F)	PRESSURE (PSIA)	LEAK RATE	
				MEASURED	CALCULATED
3	0.50	82.9064	49.1299	0.36600	0.23172
4	0.75	82.9217	49.1295	0.36262	0.23172
5	1.00	82.9513	49.1300	0.37638	0.23172
6	1.25	82.9782	49.1320	0.32071	0.23172
7	1.50	83.0094	49.1312	0.38410	0.23172
8	1.75	83.0404	49.1325	0.37268	0.23172
9	2.00	83.0701	49.1340	0.35323	0.23172
10	2.25	83.0922	49.1340	0.35730	0.23172
11	2.50	83.1237	49.1369	0.32087	0.23172
12	2.75	83.1451	49.1381	0.30465	0.23172
13	3.00	83.1686	49.1371	0.33040	0.23172
14	3.25	83.2033	49.1396	0.31459	0.23172
15	3.50	83.2174	49.1409	0.29262	0.23172
16	3.75	83.2524	49.1429	0.28742	0.23172
17	4.00	83.2783	49.1438	0.28791	0.23172
18	4.25	83.3059	49.1426	0.31365	0.23172
19	4.50	83.3363	49.1445	0.30532	0.23172
20	4.75	83.3638	49.1459	0.29963	0.23172
21	5.00	83.3851	49.1454	0.30908	0.23172
22	5.25	83.4091	49.1473	0.29671	0.23172
23	5.50	83.4372	49.1478	0.30155	0.23172
24	5.75	83.4878	49.1488	0.31859	0.23172
25	6.00	83.5062	49.1525	0.28892	0.23172
26	6.25	83.5133	49.1494	0.30647	0.23172
27	6.50	83.5311	49.1514	0.29203	0.23172
28	6.75	83.5666	49.1527	0.29441	0.23172
29	7.00	83.5909	49.1540	0.29029	0.23172
30	7.25	83.6006	49.1525	0.29671	0.23172
31	7.50	83.6178	49.1519	0.30065	0.23172
32	7.75	83.6223	49.1521	0.29188	0.23172
33	8.00	83.6345	49.1500	0.30280	0.23172
34	8.25	83.6323	49.1528	0.27551	0.23172
35	8.50	83.6153	49.1532	0.25627	0.23172
36	8.75	83.6345	49.1522	0.26463	0.23172
37	9.00	83.6272	49.1532	0.24821	0.23172
38	9.25	83.6329	49.1534	0.24274	0.23172
39	9.50	83.6356	49.1512	0.24918	0.23172
40	9.75	83.6498	49.1514	0.24827	0.23172
41	10.00	83.6687	49.1511	0.25164	0.23172
42	10.25	83.6800	49.1501	0.25526	0.23172
43	10.50	83.7058	49.1501	0.26010	0.23172
44	10.75	83.7268	49.1503	0.26185	0.23172
45	11.00	83.7539	49.1500	0.26793	0.23172
46	11.25	83.7612	49.1506	0.26228	0.23172
47	11.50	83.7770	49.1536	0.24998	0.23172
48	11.75	83.8055	49.1521	0.26168	0.23172

TABLE VI. 5 (CONT.)

DATA SET #	ELAPSED TIME (HR)	TEMP AVG (F)	PRESSURE (PSIA)	LEAK RATE	
				MEASURED	CALCULATED
49	12.00	83.8308	49.1559	0.24990	0.23172
50	12.25	83.8456	49.1548	0.25440	0.23172
51	12.50	83.8713	49.1562	0.25291	0.23172
52	12.75	83.9014	49.1581	0.25130	0.23172
53	13.00	83.9191	49.1579	0.25319	0.23172
54	13.25	83.9441	49.1597	0.25002	0.23172
55	13.50	83.9701	49.1603	0.25175	0.23172
56	13.75	83.9921	49.1614	0.25044	0.23172
57	14.00	84.0105	49.1622	0.24872	0.23172
58	14.25	84.0298	49.1624	0.24969	0.23172
59	14.50	84.0617	49.1664	0.24184	0.23172
60	14.75	84.0782	49.1656	0.24507	0.23172
61	15.00	84.1112	49.1664	0.24824	0.23172
62	15.25	84.1288	49.1676	0.24542	0.23172
63	15.50	84.1534	49.1672	0.24969	0.23172
64	15.75	84.1727	49.1706	0.24056	0.23172
65	16.00	84.2039	49.1711	0.24391	0.23172
66	16.25	84.2350	49.1726	0.24412	0.23172
67	16.50	84.2623	49.1730	0.24645	0.23172
68	16.75	84.2975	49.1738	0.24986	0.23172
69	17.00	84.3188	49.1755	0.24672	0.23172
70	17.25	84.3428	49.1757	0.24875	0.23172
71	17.50	84.3764	49.1772	0.24954	0.23172
72	17.75	84.4017	49.1772	0.25221	0.23172
73	18.00	84.4230	49.1805	0.24503	0.23172
74	18.25	84.4516	49.1806	0.24815	0.23172
75	18.50	84.4749	49.1820	0.24666	0.23172
76	18.75	84.4884	49.1826	0.24500	0.23172
77	19.00	84.5257	49.1839	0.24726	0.23172
78	19.25	84.5494	49.1846	0.24747	0.23172
79	19.50	84.5787	49.1870	0.24505	0.23172
80	19.75	84.5948	49.1886	0.24163	0.23172
81	20.00	84.6330	49.1884	0.24735	0.23172
82	20.25	84.6501	49.1894	0.24560	0.23172
83	20.50	84.6931	49.1916	0.24667	0.23172
84	20.75	84.7115	49.1920	0.24671	0.23172
85	21.00	84.7315	49.1951	0.24086	0.23172
86	21.25	84.7434	49.1958	0.23871	0.23172
87	21.50	84.7646	49.1959	0.24022	0.23172
88	21.75	84.7810	49.1976	0.23687	0.23172
89	22.00	84.8099	49.1959	0.24375	0.23172
90	22.25	84.8424	49.1971	0.24480	0.23172
91	22.50	84.8698	49.1979	0.24570	0.23172
92	22.75	84.8869	49.1988	0.24437	0.23172
93	23.00	84.9098	49.1999	0.24385	0.23172
94	23.25	84.9424	49.2023	0.24226	0.23172
95	23.50	84.9645	49.2019	0.24461	0.23172
96	23.75	84.9819	49.2029	0.24327	0.23172
97	24.00	85.0118	49.2051	0.24178	0.23172

MASS POINT LEAK RATE = 0.231725

95% UPPER CONFIDENCE LIMIT LEAK RATE = 0.2340

MAXIMUM ALLOWABLE LEAK RATE = 0.375





TABLE VI. 6

WNP-2 VERIFICATION ILRT  
TEST STARTED AT 415 ON 2/12/84  
AVERAGED MEASURED DATA

DATA SET #	TIME (HR)	TEMP (F)	DEWPT (F)	PRESSURE (PSI)
1	415	85.076	78.207	49.686
2	430	85.113	78.270	49.685
3	445	85.143	78.254	49.684
4	500	85.167	78.318	49.684
5	515	85.188	78.475	49.683
6	530	85.243	78.514	49.683
7	545	85.248	78.435	49.682
8	600	85.293	78.652	49.681
9	615	85.328	78.600	49.681
10	630	85.348	78.670	49.681
11	645	85.364	78.515	49.681
12	700	85.382	78.630	49.680
13	715	85.398	78.744	49.680
14	730	85.423	78.736	49.680
15	745	85.454	78.732	49.680
16	800	85.499	78.898	49.680
17	815	85.535	78.824	49.680
18	830	85.553	78.904	49.680
19	845	85.576	78.922	49.680
20	900	85.602	78.816	49.679
21	915	85.631	79.022	49.679
22	930	85.652	78.866	49.678
23	945	85.671	79.052	49.678
24	1000	85.709	79.168	49.678
25	1015	85.745	79.156	49.678

TABLE VI. 7

WNP-2 VERIFICATION ILRT  
TEST STARTED AT 415 ON 2/12/84  
CORRECTED DATA SUMMARY

DATA SET #	TIME (HRS)	TEMP (F)	PRESSURE AIR (PSI)	AIR MASS (LB)	PRESSURE TOTAL (PSI)
1	415	85.076	49.2074	83622.44	49.6856
2	430	85.113	49.2059	83614.26	49.6851
3	445	85.143	49.2051	83608.42	49.6841
4	500	85.167	49.2041	83603.03	49.6841
5	515	85.188	49.2006	83593.92	49.6831
6	530	85.243	49.1995	83583.59	49.6826
7	545	85.248	49.2003	83584.03	49.6821
8	600	85.293	49.1953	83568.73	49.6806
9	615	85.328	49.1962	83564.79	49.6806
10	630	85.348	49.1951	83559.85	49.6806
11	645	85.364	49.1975	83561.58	49.6806
12	700	85.382	49.1952	83554.97	49.6801
13	715	85.398	49.1934	83549.37	49.6801
14	730	85.423	49.1935	83545.70	49.6801
15	745	85.454	49.1936	83541.12	49.6801
16	800	85.499	49.1909	83529.67	49.6801
17	815	85.535	49.1921	83526.18	49.6801
18	830	85.553	49.1908	83521.25	49.6801
19	845	85.576	49.1905	83517.18	49.6801
20	900	85.602	49.1912	83514.48	49.6791
21	915	85.631	49.1874	83503.55	49.6786
22	930	85.652	49.1894	83503.71	49.6781
23	945	85.671	49.1859	83494.90	49.6776
24	1000	85.709	49.1840	83485.90	49.6776
25	1015	85.745	49.1842	83480.67	49.6776

TABLE VI. 8

WNP-2 VERIFICATION ILRT  
 TEST STARTED AT 415 ON 2/12/84  
 TOTAL TIME LEAK RATE  
 ELAPSED TIME = 6.00

DATA SET #	ELAPSED TIME (HR)	TEMP AVG (F)	PRESSURE (PSIA)	LEAK RATE	
				MEASURED	CALCULATED
2	0.25	85.1131	49.2059	0.93978	0.84354
3	0.50	85.1430	49.2051	0.80522	0.83414
4	0.75	85.1668	49.2041	0.74284	0.82474
5	1.00	85.1875	49.2006	0.81857	0.81535
6	1.25	85.2426	49.1995	0.89204	0.80595
7	1.50	85.2481	49.2003	0.73494	0.79655
8	1.75	85.2935	49.1953	0.88094	0.78715
9	2.00	85.3285	49.1962	0.82734	0.77776
10	2.25	85.3483	49.1951	0.79844	0.76836
11	2.50	85.3642	49.1975	0.69868	0.75896
12	2.75	85.3816	49.1952	0.70418	0.74957
13	3.00	85.3979	49.1934	0.69909	0.74017
14	3.25	85.4233	49.1935	0.67771	0.73077
15	3.50	85.4539	49.1936	0.66683	0.72138
16	3.75	85.4991	49.1909	0.71004	0.71198
17	4.00	85.5351	49.1921	0.69071	0.70258
18	4.25	85.5531	49.1908	0.68339	0.69319
19	4.50	85.5764	49.1905	0.67138	0.68379
20	4.75	85.6018	49.1912	0.65237	0.67440
21	5.00	85.6309	49.1874	0.68249	0.66500
22	5.25	85.6521	49.1894	0.64907	0.65560
23	5.50	85.6710	49.1859	0.66558	0.64620
24	5.75	85.7089	49.1840	0.68154	0.63681
25	6.00	85.7452	49.1842	0.67816	0.62741

TOTAL TIME LEAK RATE = 0.627411

95% UPPER CONFIDENCE LIMIT LEAK RATE = 0.7235

MAXIMUM ALLOWABLE LEAK RATE = 0.375



TABLE VI. 9  
WNP-2 VERIFICATION ILRT  
TEST STARTED AT 415 ON 2/12/84  
MASS POINT LEAK RATE  
ELAPSED TIME = 6.00

DATA SET #	ELAPSED TIME (HR)	TEMP AVG (F)	PRESSURE (PSIA)	LEAK RATE	
				MEASURED	CALCULATED
3	0.50	85.1430	49.2051	0.80522	0.64319
4	0.75	85.1668	49.2041	0.74284	0.64319
5	1.00	85.1875	49.2006	0.81857	0.64319
6	1.25	85.2426	49.1995	0.89204	0.64319
7	1.50	85.2481	49.2003	0.73494	0.64319
8	1.75	85.2935	49.1953	0.88094	0.64319
9	2.00	85.3285	49.1962	0.82734	0.64319
10	2.25	85.3483	49.1951	0.79844	0.64319
11	2.50	85.3642	49.1975	0.69868	0.64319
12	2.75	85.3816	49.1952	0.70418	0.64319
13	3.00	85.3979	49.1934	0.69909	0.64319
14	3.25	85.4233	49.1935	0.67771	0.64319
15	3.50	85.4539	49.1936	0.66683	0.64319
16	3.75	85.4991	49.1909	0.71004	0.64319
17	4.00	85.5351	49.1921	0.69071	0.64319
18	4.25	85.5531	49.1908	0.68339	0.64319
19	4.50	85.5764	49.1905	0.67138	0.64319
20	4.75	85.6018	49.1912	0.65237	0.64319
21	5.00	85.6309	49.1874	0.68249	0.64319
22	5.25	85.6521	49.1894	0.64907	0.64319
23	5.50	85.6710	49.1859	0.66558	0.64319
24	5.75	85.7089	49.1840	0.68154	0.64319
25	6.00	85.7452	49.1842	0.67816	0.64319

MASS POINT LEAK RATE = 0.643185

95% UPPER CONFIDENCE LIMIT LEAK RATE = 0.6627

MAXIMUM ALLOWABLE LEAK RATE = 0.375



TABLE VI. 10

WNP-2 BYPASS LEAKAGE TEST (25 PSID)  
TEST STARTED AT 1915 ON 2/14/84  
AVERAGED MEASURED DATA

DATA SET #	TIME (HR)	TEMP (F)	DEWPT (F)	PRESSURE (PSI)
1	1915	85.772	70.301	39.704
2	1930	85.726	70.179	39.583
3	1945	85.739	70.533	39.478
4	2000	85.786	70.533	39.373
5	2015	85.788	70.552	39.382
6	2030	85.833	70.749	39.275
7	2045	85.859	70.874	39.165
8	2100	85.916	71.143	39.055
9	2115	85.944	71.112	38.947
10	2130	85.984	71.185	38.842
11	2145	86.039	71.243	38.733
12	2200	86.069	71.336	38.625
13	2215	86.076	71.387	38.530
14	2230	86.202	71.546	38.427
15	2245	86.257	71.743	38.326
16	2300	86.293	71.766	38.224
17	2315	86.343	71.864	38.119
18	2330	86.414	71.850	38.016
19	2345	86.461	72.120	37.916
20	0	86.514	72.148	37.816
21	15	86.569	72.297	37.716
22	30	86.615	72.405	37.620
23	45	86.680	72.444	37.523
24	100	86.740	72.600	37.431
25	115	86.784	72.653	37.337





TABLE VI. 11

WNP-2 BYPASS LEAKAGE TEST (25 PSID)  
TEST STARTED AT 1915 ON 2/14/84  
CORRECTED DATA SUMMARY

DATA SET #	TIME (HRS)	TEMP (F)	PRESSURE AIR (PSI)	AIR MASS (LB)	PRESSURE TOTAL (PSI)
1	1915	85.772	39.3367	39029.46	39.7036
2	1930	85.726	39.2172	38914.20	39.5826
3	1945	85.739	39.1086	38805.53	39.4785
4	2000	85.786	39.0034	38697.84	39.3733
5	2015	85.788	39.0122	38706.40	39.3823
6	2030	85.833	38.9026	38594.51	39.2752
7	2045	85.859	38.7909	38481.85	39.1651
8	2100	85.916	38.6774	38365.17	39.0550
9	2115	85.944	38.5697	38256.40	38.9469
10	2130	85.984	38.4636	38148.34	38.8417
11	2145	86.039	38.3537	38035.52	38.7326
12	2200	86.069	38.2454	37926.08	38.6255
13	2215	86.076	38.1495	37830.41	38.5302
14	2230	86.202	38.0443	37717.44	38.4271
15	2245	86.257	37.9405	37610.74	38.3259
16	2300	86.293	37.8380	37506.69	38.2237
17	2315	86.343	37.7317	37397.79	38.1186
18	2330	86.414	37.6296	37291.85	38.0164
19	2345	86.461	37.5260	37185.94	37.9163
20	0	86.514	37.4254	37082.70	37.8161
21	15	86.569	37.3232	36977.76	37.7159
22	30	86.615	37.2256	36877.91	37.6197
23	45	86.680	37.1289	36777.70	37.5235
24	100	86.740	37.0346	36680.30	37.4313
25	115	86.784	36.9396	36583.26	37.3370

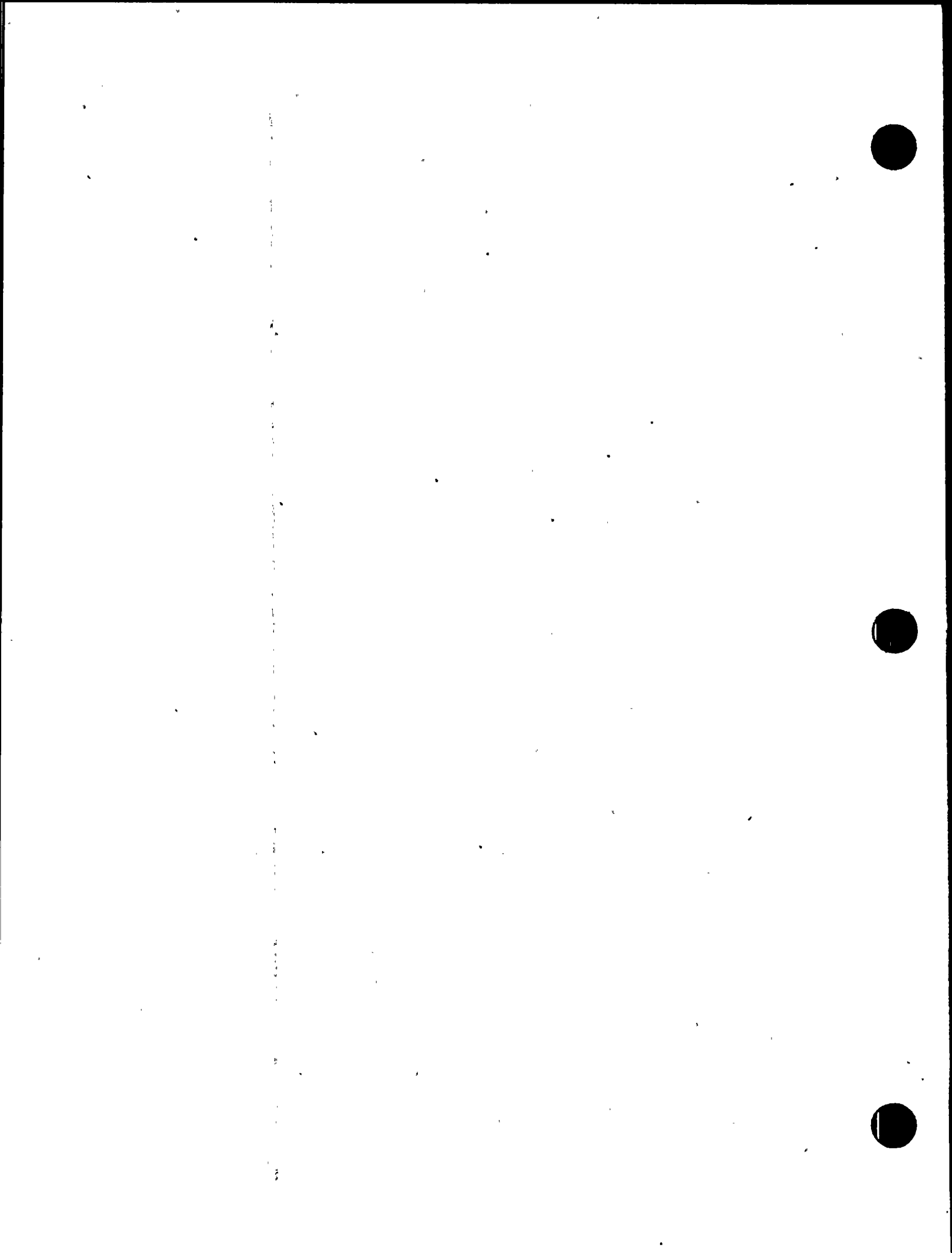

TABLE VI. 12

WNP-2 BYPASS LEAKAGE TEST (25 PSID)  
 TEST STARTED AT 1915 ON 2/14/84  
 TOTAL TIME LEAK RATE  
 ELAPSED TIME = 6.00

DATA SET #	ELAPSED TIME (HR)	TEMP AVG (F)	PRESSURE (PSIA)	LEAK RATE	
				MEASURED	CALCULATED
2	0.25	85.7256	39.2172	28.34985	24.38635
3	0.50	85.7393	39.1086	27.54016	24.41368
4	0.75	85.7859	39.0034	27.18930	24.44101
5	1.00	85.7879	39.0122	19.86575	24.46833
6	1.25	85.8325	38.9026	21.39692	24.49566
7	1.50	85.8588	38.7909	22.44902	24.52299
8	1.75	85.9165	38.6774	23.34187	24.55031
9	2.00	85.9439	38.5697	23.76808	24.57764
10	2.25	85.9839	38.4636	24.08034	24.60497
11	2.50	86.0394	38.3537	24.44719	24.63230
12	2.75	86.0689	38.2454	24.67252	24.65962
13	3.00	86.0763	38.1495	24.57737	24.68694
14	3.25	86.2021	38.0443	24.82417	24.71427
15	3.50	86.2575	37.9405	24.92550	24.74160
16	3.75	86.2930	37.8380	24.96998	24.76893
17	4.00	86.3434	37.7317	25.08337	24.79625
18	4.25	86.4142	37.6296	25.14071	24.82358
19	4.50	86.4610	37.5260	25.19120	24.85091
20	4.75	86.5137	37.4254	25.20184	24.87824
21	5.00	86.5685	37.3232	25.23229	24.90556
22	5.25	86.6146	37.2256	25.20017	24.93289
23	5.50	86.6798	37.1289	25.17506	24.96022
24	5.75	86.7396	37.0346	25.12214	24.98755
25	6.00	86.7835	36.9396	25.06987	25.01487

TOTAL TIME LEAK RATE = 25.014873

95% UPPER CONFIDENCE LIMIT LEAK RATE = 28.3393

MAXIMUM ALLOWABLE LEAK RATE = 128.5

TABLE VI. 13

WNP-2 BYPASS LEAKAGE TEST (25 PSID)  
 TEST STARTED AT 1915 ON 2/14/84  
 MASS POINT LEAK RATE  
 ELAPSED TIME = 6.00

DATA SET #	ELAPSED TIME (HR)	TEMP AVG (F)	PRESSURE (PSIA)	LEAK RATE	
				MEASURED	CALCULATED
3	0.50	85.7393	39.1086	27.54016	25.43771
4	0.75	85.7859	39.0034	27.18930	25.43771
5	1.00	85.7879	39.0122	19.86575	25.43771
6	1.25	85.8325	38.9026	21.39692	25.43771
7	1.50	85.8588	38.7909	22.44902	25.43771
8	1.75	85.9165	38.6774	23.34187	25.43771
9	2.00	85.9439	38.5697	23.76808	25.43771
10	2.25	85.9839	38.4636	24.08034	25.43771
11	2.50	86.0394	38.3537	24.44719	25.43771
12	2.75	86.0689	38.2454	24.67252	25.43771
13	3.00	86.0763	38.1495	24.57737	25.43771
14	3.25	86.2021	38.0443	24.82417	25.43771
15	3.50	86.2575	37.9405	24.92550	25.43771
16	3.75	86.2930	37.8380	24.96998	25.43771
17	4.00	86.3434	37.7317	25.08337	25.43771
18	4.25	86.4142	37.6296	25.14071	25.43771
19	4.50	86.4610	37.5260	25.19120	25.43771
20	4.75	86.5137	37.4254	25.20184	25.43771
21	5.00	86.5685	37.3232	25.23229	25.43771
22	5.25	86.6146	37.2256	25.20017	25.43771
23	5.50	86.6798	37.1289	25.17506	25.43771
24	5.75	86.7396	37.0346	25.12214	25.43771
25	6.00	86.7835	36.9396	25.06987	25.43771

MASS POINT LEAK RATE = 25.437713

95% UPPER CONFIDENCE LIMIT LEAK RATE = 25.7505

MAXIMUM ALLOWABLE LEAK RATE = 128.5



TABLE VI. 14

WNP-2 BYPASS LEAKAGE TEST (15 PSID)  
TEST STARTED AT 300 ON 2/15/84  
AVERAGED MEASURED DATA

DATA SET #	TIME (HR)	TEMP (F)	DEWPT (F)	PRESSURE (PSI)
1	300	86.847	71.924	29.996
2	315	87.022	72.279	29.932
3	330	87.150	72.457	29.869
4	345	87.269	72.647	29.804
5	400	87.337	72.924	29.740
6	415	87.437	72.988	29.675
7	430	87.519	73.303	29.612
8	445	87.581	73.480	29.548
9	500	87.646	73.561	29.433
10	515	87.743	73.617	29.420
11	530	87.813	73.737	29.355
12	545	87.862	73.853	29.292
13	600	87.945	73.807	29.225
14	615	88.020	74.054	29.159
15	630	88.087	73.999	29.093
16	645	88.149	74.097	29.031
17	700	88.214	74.211	28.968
18	715	88.300	74.302	28.907
19	730	88.355	74.415	28.840
20	745	88.432	74.438	28.779
21	800	88.482	74.388	28.717
22	815	88.567	74.604	28.655
23	830	88.623	74.693	28.599
24	845	88.697	74.887	28.537
25	900	88.771	74.904	28.486

TABLE VI. 15

WNP-2 BYPASS LEAKAGE TEST (15 PSID)  
TEST STARTED AT 300 ON 2/15/84  
CORRECTED DATA SUMMARY

DATA SET #	TIME (HRS)	TEMP (F)	PRESSURE AIR (PSI)	AIR MASS (LB)	PRESSURE TOTAL (PSI)
1	300	86.847	29.6080	29318.92	29.9957
2	315	87.022	29.5401	29242.34	29.9325
3	330	87.150	29.4742	29170.33	29.8690
4	345	87.269	29.4072	29097.67	29.8045
5	400	87.337	29.3390	29026.62	29.7401
6	415	87.437	29.2727	28955.69	29.6746
7	430	87.519	29.2058	28885.20	29.6120
8	445	87.581	29.1390	28815.84	29.5476
9	500	87.646	29.0237	28698.39	29.4334
10	515	87.743	29.0100	28679.77	29.4205
11	530	87.813	28.9428	28609.74	29.3550
12	545	87.862	28.8787	28543.83	29.2925
13	600	87.945	28.8119	28473.42	29.2250
14	615	88.020	28.7429	28401.39	29.1595
15	630	88.087	28.6773	28333.09	29.0931
16	645	88.149	28.6143	28267.67	29.0315
17	700	88.214	28.5492	28200.01	28.9680
18	715	88.300	28.4874	28134.54	28.9075
19	730	88.355	28.4185	28063.61	28.8401
20	745	88.432	28.3566	27998.61	28.7786
21	800	88.482	28.2957	27935.96	28.7170
22	815	88.567	28.2312	27867.90	28.6555
23	830	88.623	28.1733	27807.95	28.5989
24	845	88.697	28.1091	27740.78	28.5374
25	900	88.771	28.0577	27686.37	28.4863





TABLE VI. 16

WNP-2 BYPASS LEAKAGE TEST (15 PSID)  
TEST STARTED AT 300 ON 2/15/84  
TOTAL TIME LEAK RATE  
ELAPSED TIME = 6.00

DATA SET #	ELAPSED TIME (HR)	TEMP AVG (F)	PRESSURE (PSIA)	LEAK RATE	
				MEASURED	CALCULATED
2	0.25	87.0224	29.5401	25.07470	24.41284
3	0.50	87.1501	29.4742	24.32697	24.31673
4	0.75	87.2687	29.4072	24.14806	24.22061
5	1.00	87.3372	29.3390	23.92673	24.12450
6	1.25	87.4368	29.2727	23.78623	24.02839
7	1.50	87.5189	29.2058	23.66868	23.93228
8	1.75	87.5809	29.1390	23.53140	23.83616
9	2.00	87.6460	29.0237	25.39710	23.74005
10	2.25	87.7434	29.0100	23.25238	23.64394
11	2.50	87.8131	28.9428	23.22130	23.54787
12	2.75	87.8617	28.8787	23.07205	23.45176
13	3.00	87.9447	28.8119	23.07064	23.35565
14	3.25	88.0200	28.7429	23.11010	23.25954
15	3.50	88.0866	28.6773	23.05673	23.16343
16	3.75	88.1487	28.6143	22.94765	23.06732
17	4.00	88.2140	28.5492	22.89798	22.97121
18	4.25	88.3005	28.4874	22.81208	22.87509
19	4.50	88.3552	28.4185	22.83495	22.77898
20	4.75	88.4323	28.3566	22.75330	22.68287
21	5.00	88.4819	28.2957	22.64116	22.58676
22	5.25	88.5669	28.2312	22.62422	22.49065
23	5.50	88.6227	28.1733	22.48809	22.39454
24	5.75	88.6968	28.1091	22.46663	22.29842
25	6.00	88.7706	28.0577	22.27277	22.20231

TOTAL TIME LEAK RATE = 22.202312

95% UPPER CONFIDENCE LIMIT LEAK RATE = 22.9959

MAXIMUM ALLOWABLE LEAK RATE = 128.4

TABLE VI. 17

WNP-2 BYPASS LEAKAGE TEST (15 PSID)  
TEST STARTED AT 300 ON 2/15/84  
MASS POINT LEAK RATE  
ELAPSED TIME = 6.00

DATA SET #	ELAPSED TIME (HR)	TEMP AVG (F)	PRESSURE (PSIA)	LEAK RATE	
				MEASURED	CALCULATED
3	0.50	87.1501	29.4742	24.32697	22.30520
4	0.75	87.2687	29.4072	24.14806	22.30520
5	1.00	87.3372	29.3390	23.92673	22.30520
6	1.25	87.4368	29.2727	23.78623	22.30520
7	1.50	87.5189	29.2058	23.66868	22.30520
8	1.75	87.5809	29.1390	23.53140	22.30520
9	2.00	87.6460	29.0237	25.39710	22.30520
10	2.25	87.7434	29.0100	23.25238	22.30520
11	2.50	87.8131	28.9428	23.22130	22.30520
12	2.75	87.8617	28.8787	23.07205	22.30520
13	3.00	87.9447	28.8119	23.07064	22.30520
14	3.25	88.0200	28.7429	23.11010	22.30520
15	3.50	88.0866	28.6773	23.05673	22.30520
16	3.75	88.1487	28.6143	22.94765	22.30520
17	4.00	88.2140	28.5492	22.89798	22.30520
18	4.25	88.3005	28.4874	22.81208	22.30520
19	4.50	88.3552	28.4185	22.83495	22.30520
20	4.75	88.4323	28.3566	22.75330	22.30520
21	5.00	88.4819	28.2957	22.64116	22.30520
22	5.25	88.5669	28.2312	22.62422	22.30520
23	5.50	88.6227	28.1733	22.48809	22.30520
24	5.75	88.6968	28.1091	22.46663	22.30520
25	6.00	88.7706	28.0577	22.27277	22.30520

MASS POINT LEAK RATE = 22.305203

95% UPPER CONFIDENCE LIMIT LEAK RATE = 22.5140

MAXIMUM ALLOWABLE LEAK RATE = 128.4



TABLE VI. 18

WNP-2 BYPASS LEAKAGE TEST (5 PSID)  
TEST STARTED AT 1945 ON 2/15/84  
AVERAGED MEASURED DATA

DATA SET #	TIME (HR)	TEMP (F)	DEWPT (F)	PRESSURE (PSI)
1	1945	91.808	72.344	19.879
2	2000	91.776	72.427	19.862
3	2015	91.819	72.503	19.848
4	2030	91.863	72.642	19.835
5	2045	91.924	72.772	19.823
6	2100	91.999	72.782	19.810
7	2115	92.083	72.986	19.798
8	2130	92.141	73.160	19.786
9	2145	92.204	73.157	19.774
10	2200	92.321	73.375	19.762
11	2215	92.384	73.405	19.751
12	2230	92.473	73.573	19.739
13	2245	92.548	73.748	19.728
14	2300	92.625	73.685	19.717
15	2315	92.691	73.988	19.706
16	2330	92.768	74.060	19.695
17	2345	92.844	74.108	19.683



TABLE VI. 19

WNP-2 BYPASS LEAKAGE TEST (5 PSID)  
TEST STARTED AT 1945 ON 2/15/84  
CORRECTED DATA SUMMARY

DATA SET #	TIME (HRS)	TEMP (F)	PRESSURE AIR (PSI)	AIR MASS (LB)	PRESSURE TOTAL (PSI)
1	1945	91.808	19.4853	19121.56	19.8786
2	2000	91.776	19.4673	19104.99	19.8617
3	2015	91.819	19.4524	19088.86	19.8478
4	2030	91.863	19.4376	19072.86	19.8349
5	2045	91.924	19.4240	19057.37	19.8230
6	2100	91.999	19.4109	19041.89	19.8100
7	2115	92.083	19.3962	19024.62	19.7981
8	2130	92.141	19.3819	19008.63	19.7862
9	2145	92.204	19.3701	18994.82	19.7743
10	2200	92.321	19.3551	18976.11	19.7623
11	2215	92.384	19.3438	18962.85	19.7514
12	2230	92.473	19.3295	18945.80	19.7394
13	2245	92.548	19.3162	18930.16	19.7285
14	2300	92.625	19.3052	18916.70	19.7166
15	2315	92.691	19.2900	18899.64	19.7057
16	2330	92.768	19.2780	18885.27	19.6947
17	2345	92.844	19.2655	18870.34	19.6828





TABLE VI. 20

WNP-2 BYPASS LEAKAGE TEST (5 PSID)  
TEST STARTED AT 1945 ON 2/15/84  
TOTAL TIME LEAK RATE  
ELAPSED TIME = 4.00

DATA SET #	ELAPSED TIME (HR)	TEMP AVG (F)	PRESSURE (PSIA)	LEAK RATE	
				MEASURED	CALCULATED
2	0.25	91.7758	19.4673	8.31820	8.20124
3	0.50	91.8193	19.4524	8.20845	8.17996
4	0.75	91.8629	19.4376	8.14944	8.15867
5	1.00	91.9236	19.4240	8.05609	8.13739
6	1.25	91.9991	19.4109	7.99955	8.11611
7	1.50	92.0826	19.3962	8.11112	8.09483
8	1.75	92.1410	19.3819	8.09935	8.07354
9	2.00	92.2040	19.3701	7.95347	8.05226
10	2.25	92.3211	19.3551	8.11350	8.03098
11	2.50	92.3841	19.3438	7.96758	8.00969
12	2.75	92.4726	19.3295	8.02149	7.98841
13	3.00	92.5480	19.3162	8.00736	7.96713
14	3.25	92.6255	19.3052	7.91121	7.94584
15	3.50	92.6912	19.2900	7.95784	7.92456
16	3.75	92.7677	19.2780	7.90866	7.90328
17	4.00	92.8440	19.2655	7.88254	7.88200

TOTAL TIME LEAK RATE = 7.881996  
95% UPPER CONFIDENCE LIMIT LEAK RATE = 8.0088  
MAXIMUM ALLOWABLE LEAK RATE = 116.7

TABLE VI. 21

WNP-2 BYPASS LEAKAGE TEST (5 PSID)  
TEST STARTED AT 1945 ON 2/15/84  
MASS POINT LEAK RATE  
ELAPSED TIME = 4.00

DATA SET #	ELAPSED TIME (HR)	TEMP AVG (F)	PRESSURE (PSIA)	LEAK RATE	
				MEASURED	CALCULATED
3	0.50	91.8193	19.4524	8.20845	7.89670
4	0.75	91.8629	19.4376	8.14944	7.89670
5	1.00	91.9236	19.4240	8.05609	7.89670
6	1.25	91.9991	19.4109	7.99955	7.89670
7	1.50	92.0826	19.3962	8.11112	7.89670
8	1.75	92.1410	19.3819	8.09935	7.89670
9	2.00	92.2040	19.3701	7.95347	7.89670
10	2.25	92.3211	19.3551	8.11350	7.89670
11	2.50	92.3841	19.3438	7.96758	7.89670
12	2.75	92.4726	19.3295	8.02149	7.89670
13	3.00	92.5480	19.3162	8.00736	7.89670
14	3.25	92.6255	19.3052	7.91121	7.89670
15	3.50	92.6912	19.2900	7.95784	7.89670
16	3.75	92.7677	19.2780	7.90866	7.89670
17	4.00	92.8440	19.2655	7.88254	7.89670

MASS POINT LEAK RATE = 7.896704

95% UPPER CONFIDENCE LIMIT LEAK RATE = 7.9455

MAXIMUM ALLOWABLE LEAK RATE = 116.7



TABLE VI. 22

WNP-2 BYPASS LEAKAGE TEST (1.5 PSID)  
TEST STARTED AT 500 ON 2/16/84  
AVERAGED MEASURED DATA

DATA SET #	TIME (HR)	TEMP (F)	DEWPT (F)	PRESSURE (PSI)
1	500	94.097	72.523	16.093
2	515	94.244	72.694	16.094
3	530	94.328	72.809	16.093
4	545	94.415	72.859	16.091
5	600	94.502	73.125	16.089
6	615	94.584	73.275	16.087
7	630	94.654	73.280	16.084
8	645	94.741	73.529	16.082
9	700	94.811	73.476	16.080
10	715	94.880	73.805	16.077
11	730	94.953	73.717	16.075
12	745	95.028	73.836	16.073
13	800	95.099	74.149	16.070
14	815	95.174	74.185	16.068
15	830	95.221	74.218	16.065
16	845	95.274	74.488	16.063
17	900	95.342	74.600	16.060

TABLE VI. 23

WNP-2 BYPASS LEAKAGE TEST (1.5 PSID)  
TEST STARTED AT 500 ON 2/16/84  
CORRECTED DATA SUMMARY

DATA SET #	TIME (HRS)	TEMP (F)	PRESSURE AIR (PSI)	AIR MASS (LB)	PRESSURE TOTAL (PSI)
1	500	94.097	15.6974	15340.72	16.0931
2	515	94.244	15.6961	15335.38	16.0941
3	530	94.328	15.6936	15330.56	16.0931
4	545	94.415	15.6909	15325.55	16.0911
5	600	94.502	15.6853	15317.66	16.0891
6	615	94.584	15.6813	15311.47	16.0871
7	630	94.654	15.6783	15306.62	16.0842
8	645	94.741	15.6729	15298.93	16.0822
9	700	94.811	15.6716	15295.76	16.0802
10	715	94.880	15.6641	15286.50	16.0772
11	730	94.953	15.6633	15283.72	16.0752
12	745	95.028	15.6597	15278.10	16.0732
13	800	95.099	15.6523	15268.96	16.0702
14	815	95.174	15.6498	15264.46	16.0682
15	830	95.221	15.6463	15259.80	16.0652
16	845	95.274	15.6405	15252.67	16.0632
17	900	95.342	15.6360	15246.42	16.0603

TABLE VI. 24

WNP-2 BYPASS LEAKAGE TEST (1.5 PSID)  
TEST STARTED AT 500 ON 2/16/84  
TOTAL TIME LEAK RATE  
ELAPSED TIME = 4.00

DATA SET #	ELAPSED TIME (HR)	TEMP AVG (F)	PRESSURE (PSIA)	LEAK RATE	
				MEASURED	CALCULATED
2	0.25	94.2438	15.6961	3.34035	3.37226
3	0.50	94.3278	15.6936	3.17822	3.39806
4	0.75	94.4147	15.6909	3.16452	3.42386
5	1.00	94.5021	15.6853	3.60773	3.44966
6	1.25	94.5836	15.6813	3.66074	3.47546
7	1.50	94.6541	15.6783	3.55662	3.50126
8	1.75	94.7413	15.6729	3.73625	3.52707
9	2.00	94.8110	15.6716	3.51677	3.55287
10	2.25	94.8803	15.6641	3.76993	3.57867
11	2.50	94.9532	15.6633	3.56696	3.60447
12	2.75	95.0281	15.6597	3.56251	3.63027
13	3.00	95.0993	15.6523	3.74242	3.65607
14	3.25	95.1737	15.6498	3.67077	3.68187
15	3.50	95.2206	15.6463	3.61697	3.70767
16	3.75	95.2738	15.6405	3.67323	3.73347
17	4.00	95.3424	15.6360	3.68828	3.75928

TOTAL TIME LEAK RATE = 3.759275

95% UPPER CONFIDENCE LIMIT LEAK RATE = 4.0407

MAXIMUM ALLOWABLE LEAK RATE = 78.400

TABLE VI. 25

WNP-2 BYPASS LEAKAGE TEST (1.5 PSID)  
TEST STARTED AT 500 ON 2/16/84  
MASS POINT LEAK RATE  
ELAPSED TIME = 4.00

DATA SET #	ELAPSED TIME (HR)	TEMP AVG (F)	PRESSURE (PSIA)	LEAK RATE	
				MEASURED	CALCULATED
3	0.50	94.3278	15.6936	3.17822	3.70620
4	0.75	94.4147	15.6909	3.16452	3.70620
5	1.00	94.5021	15.6853	3.60773	3.70620
6	1.25	94.5836	15.6813	3.66074	3.70620
7	1.50	94.6541	15.6783	3.55662	3.70620
8	1.75	94.7413	15.6729	3.73625	3.70620
9	2.00	94.8110	15.6716	3.51677	3.70620
10	2.25	94.8803	15.6641	3.76993	3.70620
11	2.50	94.9532	15.6633	3.56696	3.70620
12	2.75	95.0281	15.6597	3.56251	3.70620
13	3.00	95.0993	15.6523	3.74242	3.70620
14	3.25	95.1737	15.6498	3.67077	3.70620
15	3.50	95.2206	15.6463	3.61697	3.70620
16	3.75	95.2738	15.6405	3.67323	3.70620
17	4.00	95.3424	15.6360	3.68828	3.70620

MASS POINT LEAK RATE = 3.706197

95% UPPER CONFIDENCE LIMIT LEAK RATE = 3.7680

MAXIMUM ALLOWABLE LEAK RATE = 78.400





ATTACHMENT VII  
GRAPHS

Table of Contents

1. PCILRT Averaged Temperature ( $^{\circ}$ F) Versus Time
2. PCILRT Averaged Dewpoint ( $^{\circ}$ F) Versus Time
3. PCILRT Averaged Absolute Pressure Versus Time
4. PCILRT Air Mass Versus Time
5. LRVT Averaged Temperature ( $^{\circ}$ F) Versus Time
6. LRVT Averaged Dewpoint ( $^{\circ}$ F) Versus Time
7. LRVT Averaged Absolute Pressure Versus Time
8. LRVT Air Mass Versus Time

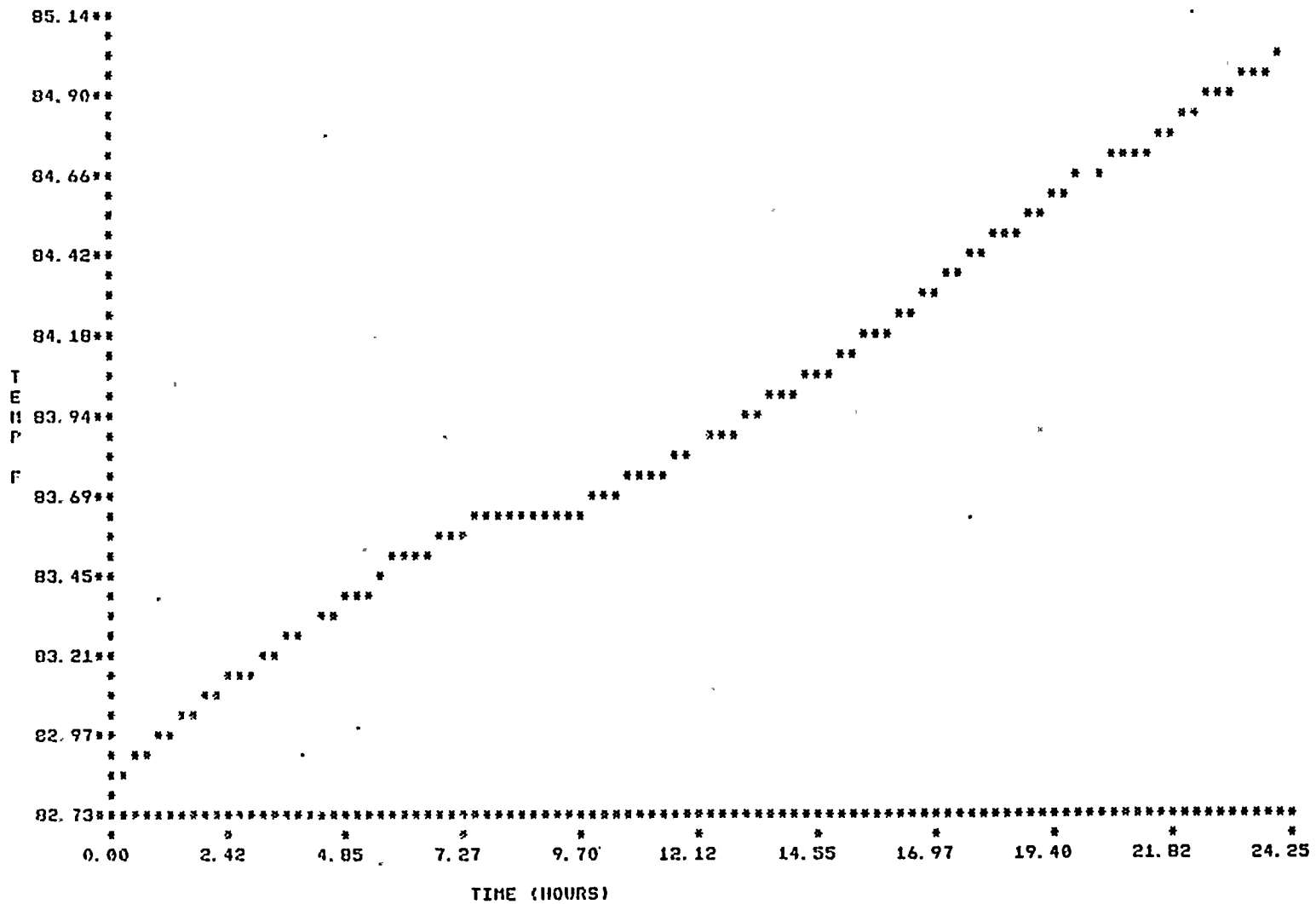

FIGURE VII 1 PCILRT AVERAGED TEMPERATURE VS TIME



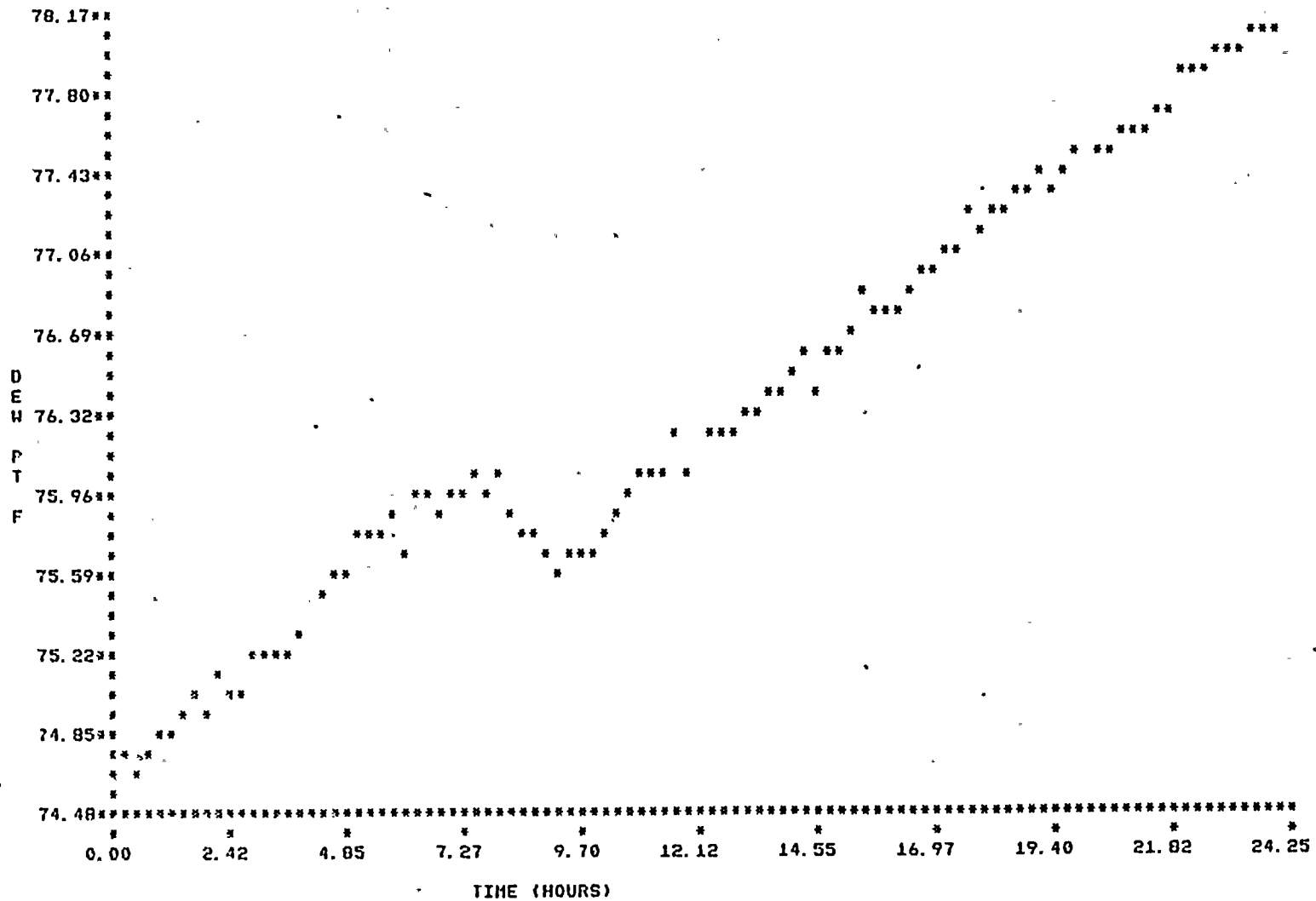

FIGURE VII.2 PCILRT AVERAGED DEWPOINT VS TIME



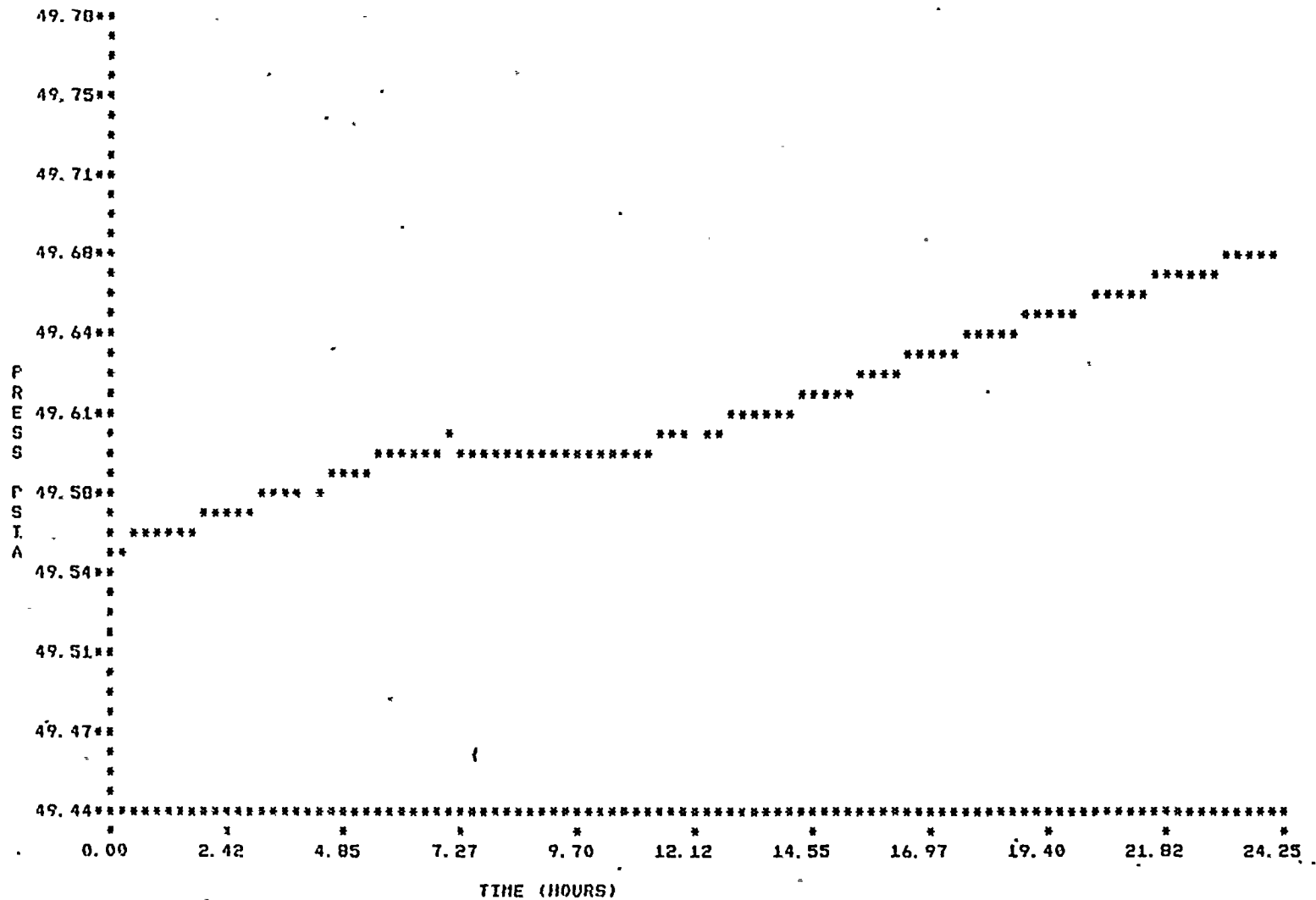

FIGURE VII.3 PCTLR1 AVERAGED ABSOLUTE PRESSURE VS TIME

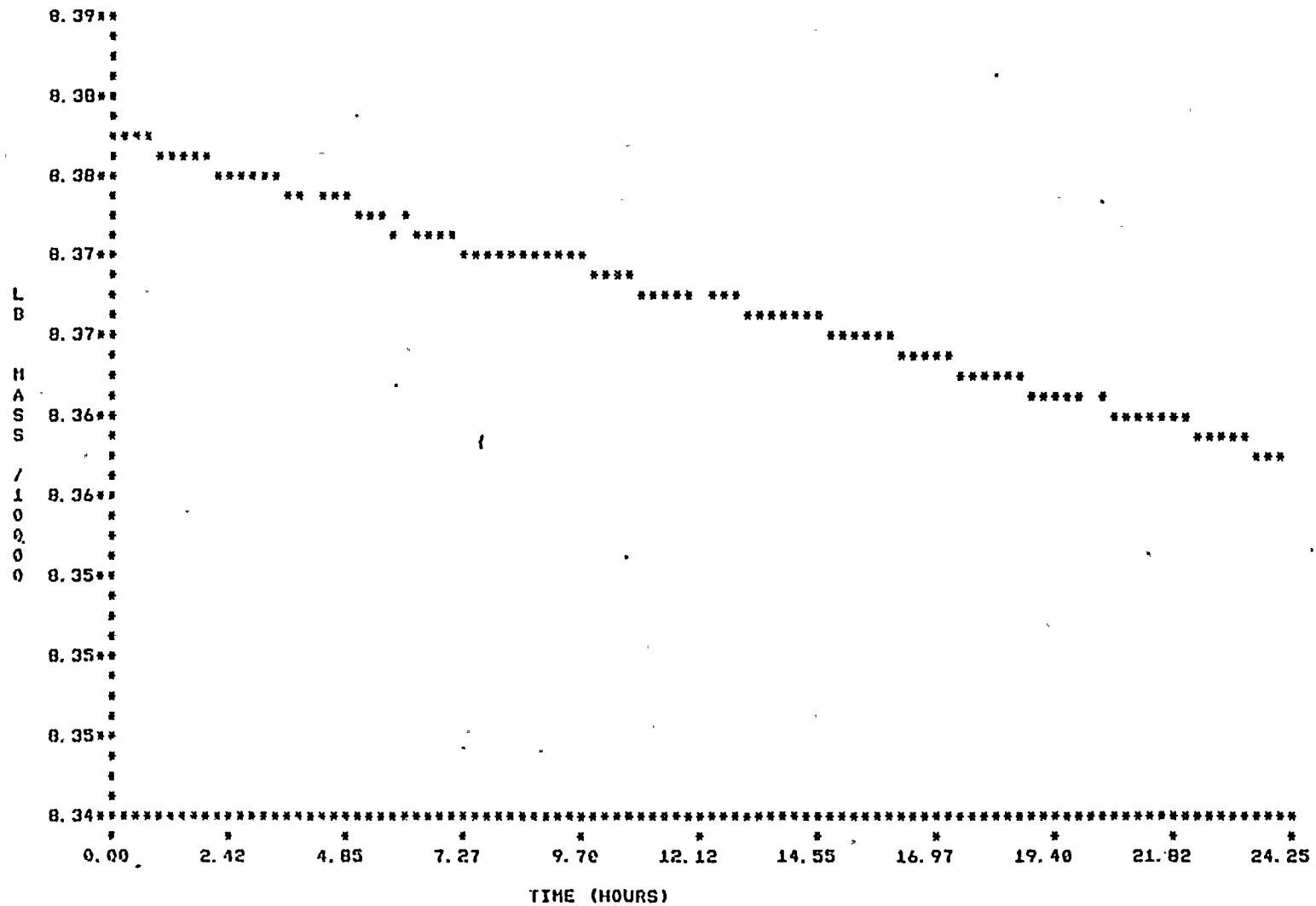

FIGURE VII.4 PCILRT AIR MASS VS TIME

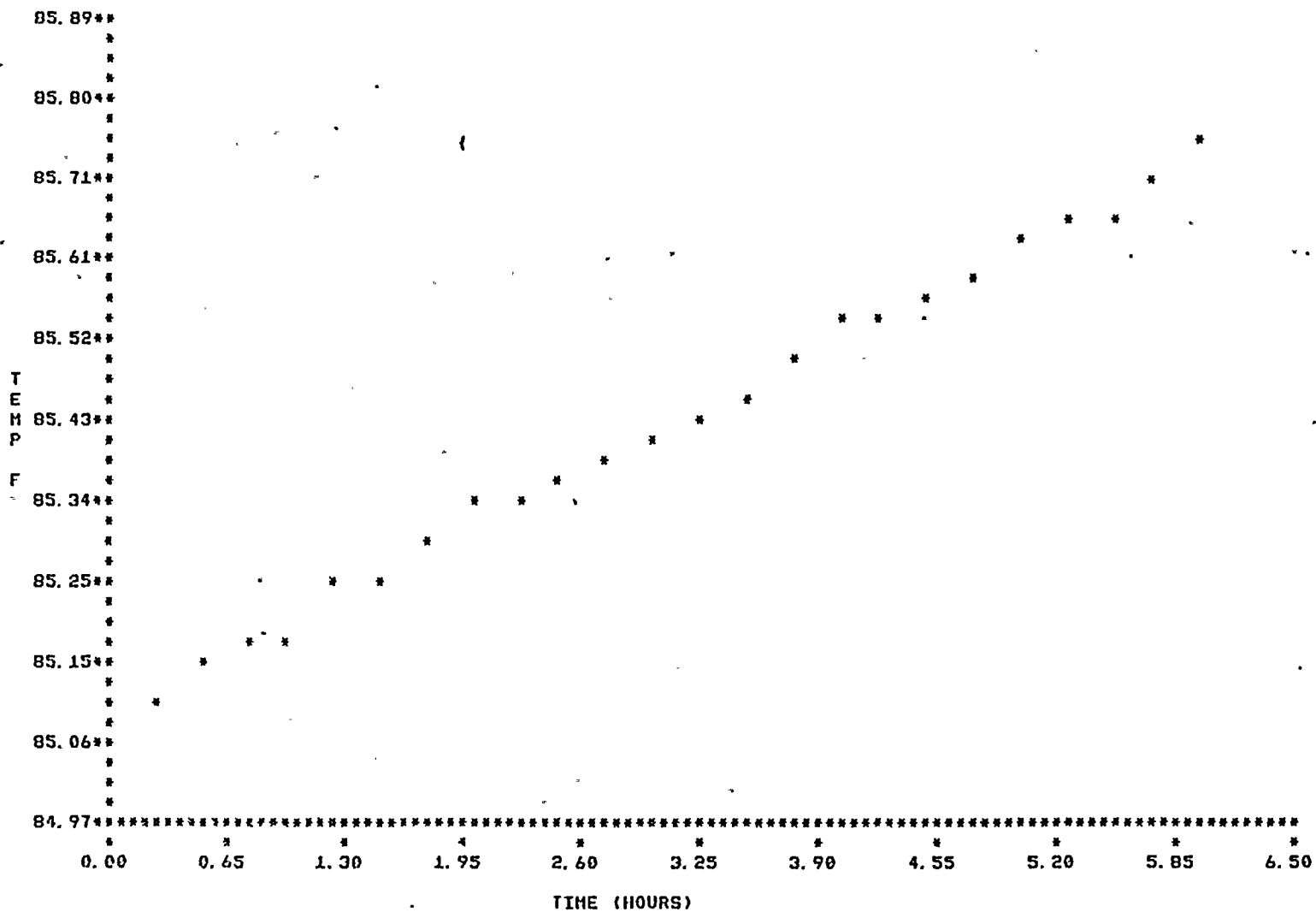

FIGURE VII.5 LRVT AVERAGED TEMPERATURE VERSUS TIME





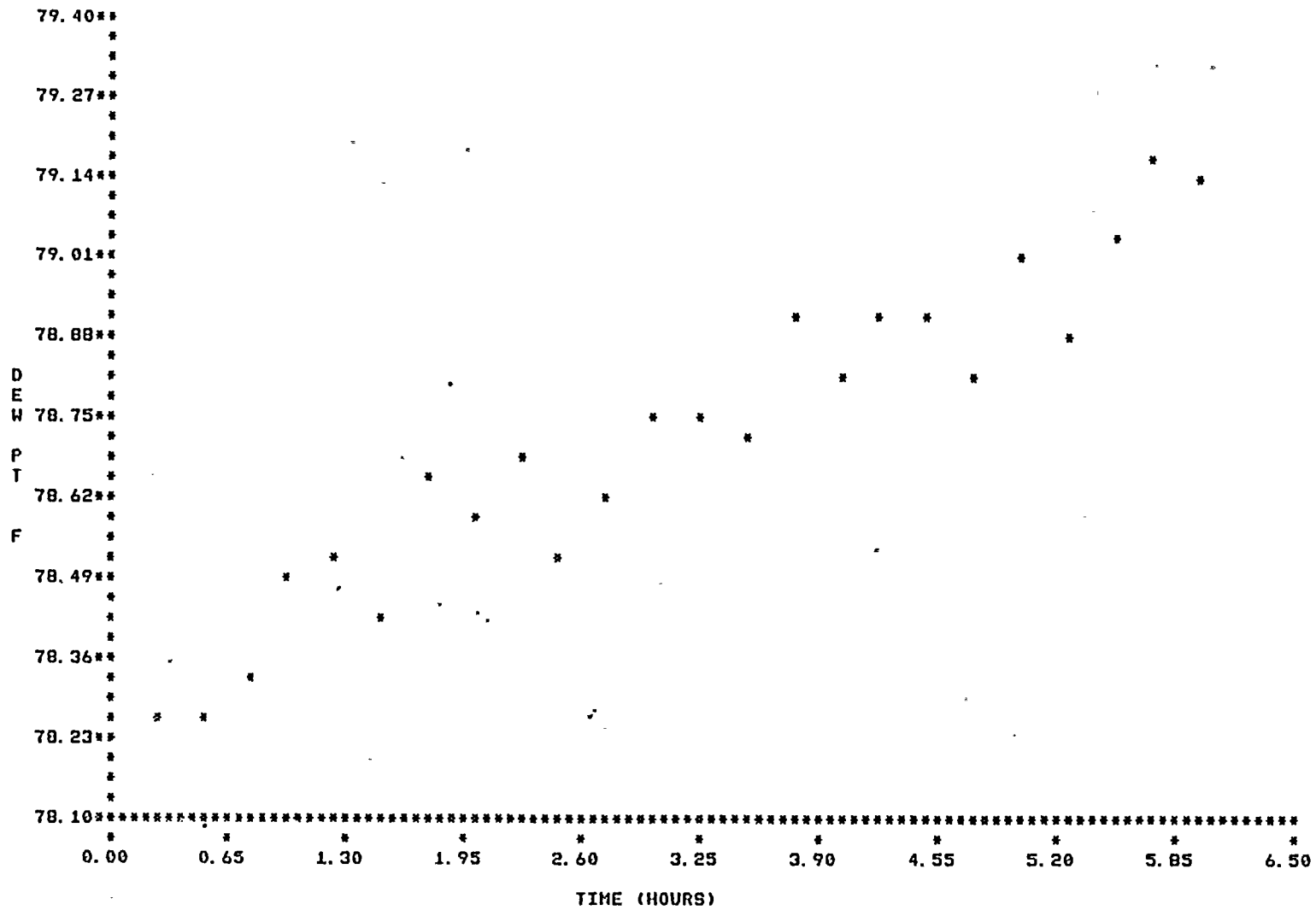

FIGURE VII. 6 LRV T AVERAGED DEWPOINT VS TIME

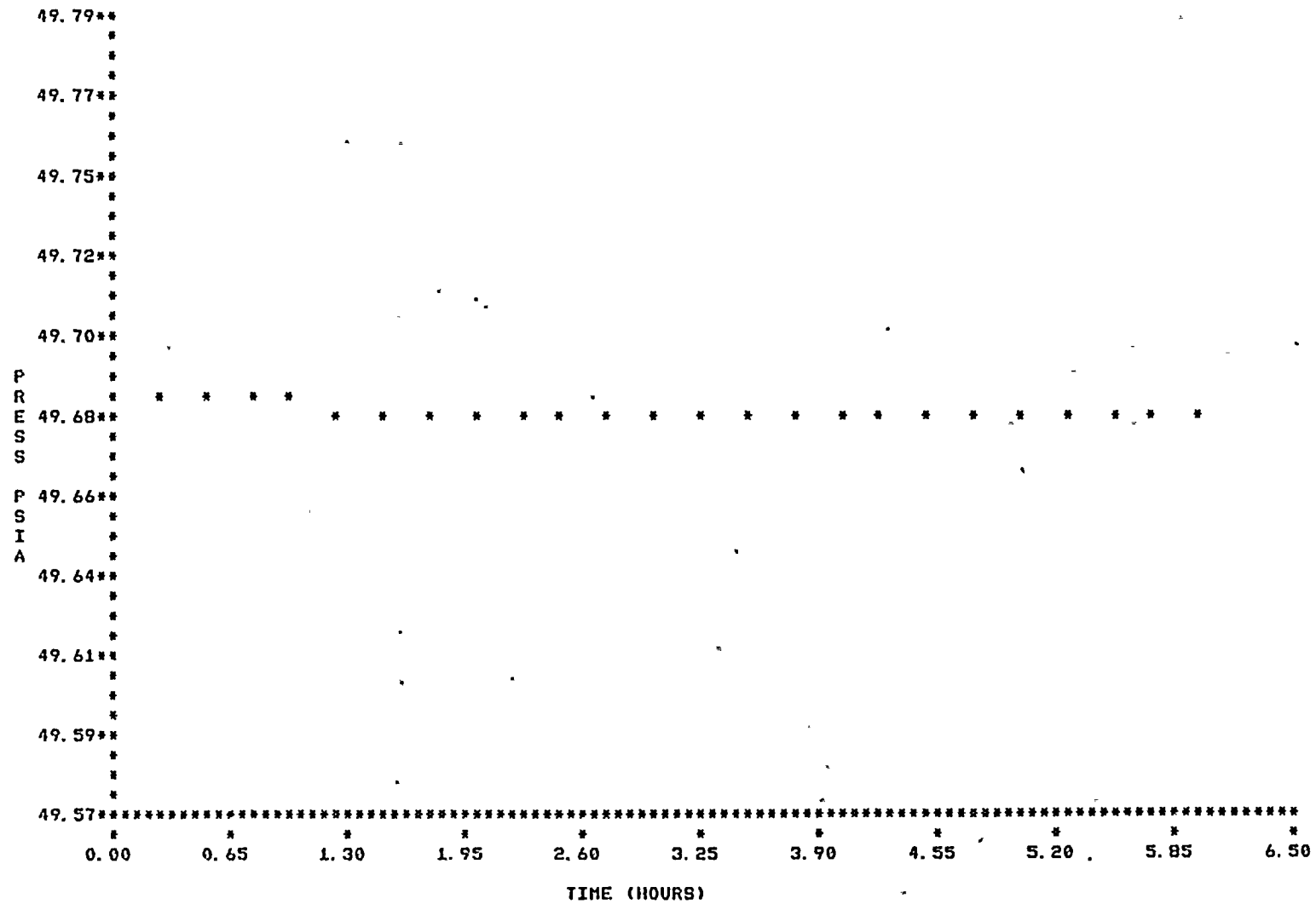
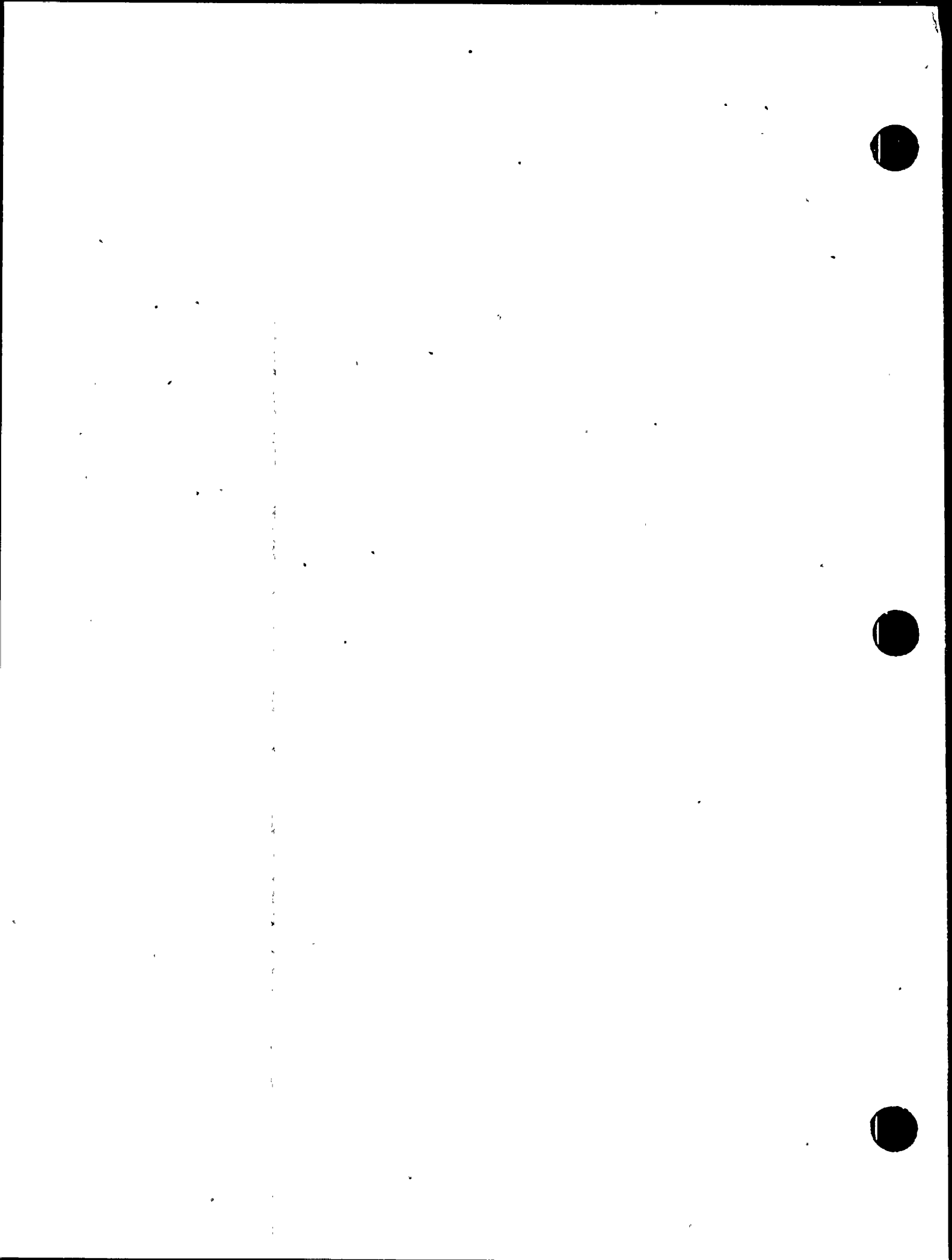

FIGURE VII 7 LRVT AVERAGED ABSOLUTE PRESSURE VS TIME



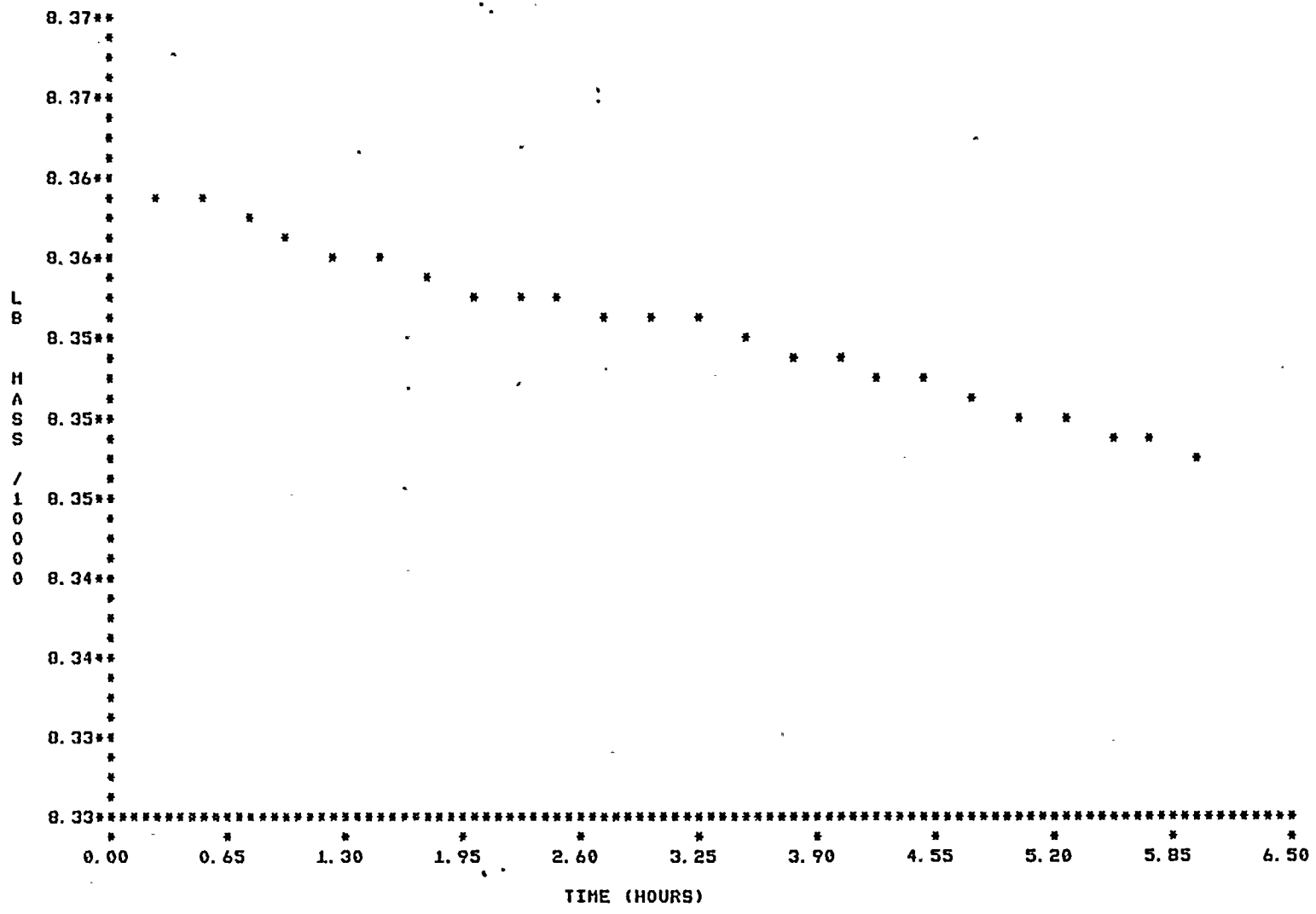

FIGURE VII. 8 LRVT AIR MASS VS TIME



ATTACHMENT VIII  
GLOSSARY

- BLFI - Bypass Leakage Flow Instrument
- BLR - Bypass Leakage Rate (leakage from the Drywell to the Wetwell across the Drywell Floor)
- BLRT - Bypass Leakage Rate Test
- \_\_\_# BLRT- Specific BLRT wherein the test differential pressure (in psid) is specified. Could be 25, 15, 5, or 1.5# BLRT
- CIV - Containment Isolation Valve
- DAS - Data Acquisition System
- DF - Drywell Floor (horizontal concrete slab separating the Drywell from the Wetwell)
- FVM - Flow Verification Monitor (part of ILRMS)
- ILRMS - Integrated Leak Rate Monitoring System
- ILRT - Same as PCILRT
- ILRTA - Integrated Leak Rate Test Analysis (Ref. 5.12)
- LLRT - Local Leakage Rate Test (Type B or C test)
- LR - Leakage Rate
- LRVT - Leakage Rate Verification Test (the supplemental test performed just after the Type A test)
- MSIV - Main Steam Isolation Valve (CIVs in Main Steam Lines)
- OILR - Overall Integrated Leakage Rate
- Pa - Peak Accident Pressure (34.7 psig)
- PCILRT - Primary Containment Integrated Leakage Rate Test (Type A Test)
- Pd - PRC Design Pressure (45 psig)
- PRC - Primary Reactor Containment
- RB - Reactor Building
- RPV - Reactor Pressure Vessel
- SCCM - Standard Cubic Centimeters per Minute
- UCL - Upper Confidence Limit
- w/o/d - Weight Percent Per Day
- X - \_\_\_ - PRC Penetration (Blank filled in with the specific identifying numeral)

