

REGULATORY INFORMATION DISTRIBUTION SYSTEM (RIDS)

ACCESSION NBR: 8306200243 DOC. DATE: 83/06/10 NOTARIZED: NO DOCKET #
 FACIL: 50-397 WPPSS Nuclear Project, Unit 2, Washington Public Powe 05000397
 AUTH. NAME: BOUCHEY, G. D. AUTHOR AFFILIATION: Washington Public Power Supply System
 RECIP. NAME: SCHWENCER, A. RECIPIENT AFFILIATION: Licensing Branch 2

SUBJECT: Forwards three listed repts to expedite resolution of SER
 Outstanding Issue 13 re control sys failures, in response to
 NRC Questions 031.135, 137 & 138.

DISTRIBUTION CODE: B001S COPIES RECEIVED: LTR 1 ENCL 50 SIZE: 11 x 214
 TITLE: Licensing Submittal: PSAR/FSAR Amdts & Related Correspondence

NOTES: Limited Dist.

	RECIPIENT		COPIES			RECIPIENT		COPIES	
	ID	CODE/NAME	LTR	ENCL		ID	CODE/NAME	LTR	ENCL
	NRR/DL/ADL		1	0		NRR LB2 BC	1	0	
	NRR LB2 LA		1	0		AULUCK, R.	01	1	1
INTERNAL:	ELD/HDS2		1			IE FILE		1	
	IE/DEPER/ERB	36	3			IE/DEPER/IRB	35	1	
	IE/DEQA/QAB	21	1			NRR/DE/AEAB		1	
	NRR/DE/CEB	11	1			NRR/DE/EHEB		1	
	NRR/DE/eqB	13	2			NRR/DE/GB	28	2	
	NRR/DE/MEB	18	1			NRR/DE/MTEB	17	1	
	NRR/DE/SAB	24	1			NRR/DE/SGEB	25	1	
	NRR/DE/SGEB	30	1			NRR/DHFS/HFEB40		1	
	NRR/DHFS/LQB	32	1			NRR/DHFS/PSRB		1	
	NRR/DL/SSPB		1			NRR/DSI/AEB	26	1	
	NRR/DSI/ASB		1			NRR/DSI/CPB	10	1	
	NRR/DSI/CSB	09	1			NRR/DSI/ICSB	16	1	
	NRR/DSI/METB	12	1			NRR/DSI/PSB	19	1	
	NRR/DSI/RAB	22	1			NRR/DSI/RSB	23	1	
	REG FILE	04	1	1		RGNS		3	
	RM/DDAMI/MIB		1	0					
EXTERNAL:	ACRS	41	6	0		BNL (AMDTS ONLY)		1	0
	DMB/DSS (AMDTS)		1	0		FEMA-REP DIV	39	1	0
	LPDR	03	1	1		NRC PDR	02	1	1
	NSIC	05	1	1		NTIS		1	1

54 Ltrs 1 Encl

TOTAL NUMBER OF COPIES REQUIRED: LTR 54 ENCL

Faint, illegible text at the top of the page, possibly bleed-through from the reverse side.

Vertical text on the left side, possibly a page number or reference code.

Vertical text in the center of the page, possibly a title or section header.

Vertical text on the right side, possibly a date or time stamp.

Faint, illegible text at the bottom of the page, possibly bleed-through from the reverse side.

Washington Public Power Supply System

P.O. Box 968 3000 George Washington Way Richland, Washington 99352 (509) 372-5000

June 10, 1983
G02-83-509

Docket No. 50-397

Director of Nuclear Reactor Regulation
Attention: Mr. A. Schwencer, Chief
Licensing Branch No. 2
Division of Licensing
U.S. Nuclear Regulatory Commission
Washington, D.C. 20555

Dear Mr. Schwencer:

Subject: NUCLEAR PROJECT NO. 2
CONTROL SYSTEM FAILURES QUESTIONS,
WNP-2 SER #3, OUSTANDING ISSUE #13

In order to expedite resolution of SER Outstanding Issue #13, enclosed are five (5) copies of the following reports:

- NRC Question 031.135, "Loss of Non-Class IE Instrumentation and Control Power System Bus During Power Operation (IE Bulletin 79-27)"
- NRC Question 031.137, "Qualification of Control Systems (IE Information Notice 79-22)"
- NRC Question 031.138, "Control System Failures"

These reports have been prepared in response to the above NRC questions. Internal Supply System review of these reports is not totally complete; however, we are confident that any changes to these reports will be minor. We expect to provide our formal responses to Questions 031.135, 031.137, and 031.138 by June 17, 1983.

Very truly yours,



G. D. Bouchey
Manager, Nuclear Safety and Regulatory Programs

GDB/jca

cc: R Auluck - NRC
WS Chin - BPA
A Toth - NRC Site

*13001
1/5
Limited
Dist*

8306200243 830610
PDR ADDCK 05000397
E PDR



Handwritten text in a rounded rectangular box at the bottom right of the page.

8306200243

CONTENTS

- 1.0 ANALYSIS OBJECTIVE
- 2.0 ANALYSIS METHODOLOGY
- 3.0 CONCLUSIONS

APPENDICES AND ILLUSTRATIONS

- FIGURE 1 HANFORD COLD SHUTDOWN SYSTEMS PATHS
- FIGURE 2 BUS SYSTEM CASCADE CHART
- APPENDIX A POWER BUS ANALYSIS TABLES

1.0 ANALYSIS OBJECTIVE

The overall analysis objective was to determine whether the loss of power to any bus would jeopardize being able to bring the plant to cold shutdown.

This review was conducted in response to IE Bulletin 79-27 which identified specific actions to be taken in accomplishing the review. These actions are as detailed below:

- 1) Review the Class 1E and Non-Class 1E buses supplying power to safety and non-safety related instrumentation and control systems which could affect the ability to achieve a cold shutdown condition using existing plant operating procedures or procedures developed for each bus in the event of its failure.
- 2) Identify the instrument and control system loads connected to the bus and evaluate the effects of loss of power to these loads including the ability to achieve a cold shutdown condition.
- 3) Identify and review the alarm and/or indication provided in the control room to alert the operator to the loss of power to the bus.
- 4) Identify alternate indication and/or control circuits which may be powered from other Non-Class 1E or Class 1E instrumentation and control buses.
- 5) Identify methods for restoring power to the buses.
- 6) Prepare emergency procedures or review existing ones that will be used by control room operators, including procedures required to achieve a cold shutdown condition, upon loss of power to each Class 1E and Non-Class 1E bus supplying power to safety and non-safety related instrument and control systems.

- 7) Describe any proposed design modifications or administrative controls to be implemented resulting from these procedures, and the proposed schedule for implementing the changes.

A comprehensive approach was developed to analyze the consequences of a bus failure during cold shutdown. Details of this approach are identified in the analysis methodology section. Alternate cold shutdown paths, conclusions, and followup recommendations are also discussed in their respective sections.

This report with its appendices and illustrations was prepared by the General Electric Company (GE) for Washington Public Power Supply System (WPPSS). Significant technical contribution was also provided by Burns and Roe, Inc. (BRI).

2.0 ANALYSIS METHODOLOGY

The information required to analyze the effect of a bus failure on cold shutdown was obtained from both GE and BRI.

The division of responsibility for the information and analysis gathering was as follows:

<u>ACTIVITY</u>	<u>ASSIGNED TO</u>
2.1 Identify Required Systems	GE & BRI
2.2 Identify Required Devices	GE & BRI
2.3 Identify Required Buses	GE & BRI
2.4 Determine & Summarize Normal & Alternate Shutdown Paths	GE
2.5 Determine IE and Non-IE Loads	GE & BRI
2.6 Analyze Bus Loss During Shutdown	GE
2.7 Analyze Cascade Effect of Combined Bus Losses	GE
2.8 Determine Bus Loss Annunciation	GE & BRI
2.9 Review Plant Procedures to Verify Appropriate Steps During Bus Loss	WPPSS
2.10 Modify/Augment Plant Procedures if Necessary	WPPSS



2.1 IDENTIFY REQUIRED SYSTEMS

This step established the systems required for plant shutdown to a cold shutdown state. A list of WNP-2 plant systems and subsystems was compiled and reviewed to determine only those systems necessary to achieve a cold shutdown. These systems were grouped together (see Figure 1) in their required normal and alternate shutdown paths. A detailed discussion of the methods used to develop Figure 1 is discussed in Section 2.4 of this report.

2.2 IDENTIFY REQUIRED DEVICES

Since not all devices in a system are required for shutdown only those devices the operator would manipulate in going to cold shutdown were evaluated. System operating procedures (PPM's) were reviewed in conjunction with the plant shutdown procedure (PPM 23.2.6) to properly evaluate devices required. The devices required for cold shutdown, the associated annunciators, and power busses were analyzed system by system.

2.3 IDENTIFY REQUIRED BUSES

The devices discussed in Section 2.2 were reviewed to determine their power supply bus(es). All power supply buses which have cold shutdown devices were then arranged to show how they are interconnected. Annunciators and loss of power alarms for the buses were reviewed to determine if the operator would be alerted on loss of a bus. Figure 2 shows all required buses, breakers and annunciators for these buses.

2.4 DETERMINE AND SUMMARIZE NORMAL AND ALTERNATE SHUTDOWN PATHS

The shutdown paths are as identified in Figure 1. The information required to determine the three basic shutdown paths was obtained from plant procedures, P&ID's and WNP-2 FSAR system descriptions.

With reference to Figure 1, the alphabetical indicator, located in parenthesis in each system block, (e.g., (E); (F); etc.) represents the cross

reference code to the system device table Appendix "A". Although each system description block is located in its own respective shutdown path, the Figure does not necessarily show the sequential use of a particular system during the cold shutdown operation. For example; in the normal cool down path , feedwater (Group (J)) is shown as the fifth (5th) system in line. Control of feedwater occurs to some degree, prior and during condensate and condenser vacuum (Group (F)) operations.

In addition, the use of normal RHR cooling occurs as a last event irrespective of the shutdown path selection (and use). Because of this, the RHR Shutdown Cooling Mode (L), is shown as the last event in the Normal Cooldown Path, and is essentially duplicated by control of RHR "A" or RHR "B" in the alternate shutdown cooling modes.

2.5 DETERMINE 1E AND NON-1E LOADS

A review of the plant single line diagrams identified the 1E or Non-1E class status. These designators have been included in the "Power Bus Analysis Tables", Appendix "A", under the heading of "Essentiality Code".

2.6 ANALYZE BUS LOSS DURING SHUTDOWN

This step consisted of determining the affect of a bus loss on the ability to continue in the particular shutdown path that was being used at the time the bus loss occurred. Information presented in Figures 1 and 2 provided the facts necessary to analyze the consequences of a bus loss.

The conclusion effect of continuing in the existing shutdown mode is elaborated on in the affects column of the Appendix A document.

2.7 ANALYZE CASCADE EFFECT OF COMBINED BUS LOSSES

This step in the analysis is a continuation of Paragraph 2.6, where the consequences of an upstream bus loss will affect the cold shutdown path. In all cases, transfer to alternate power or transfer to other shutdown modes were possible.

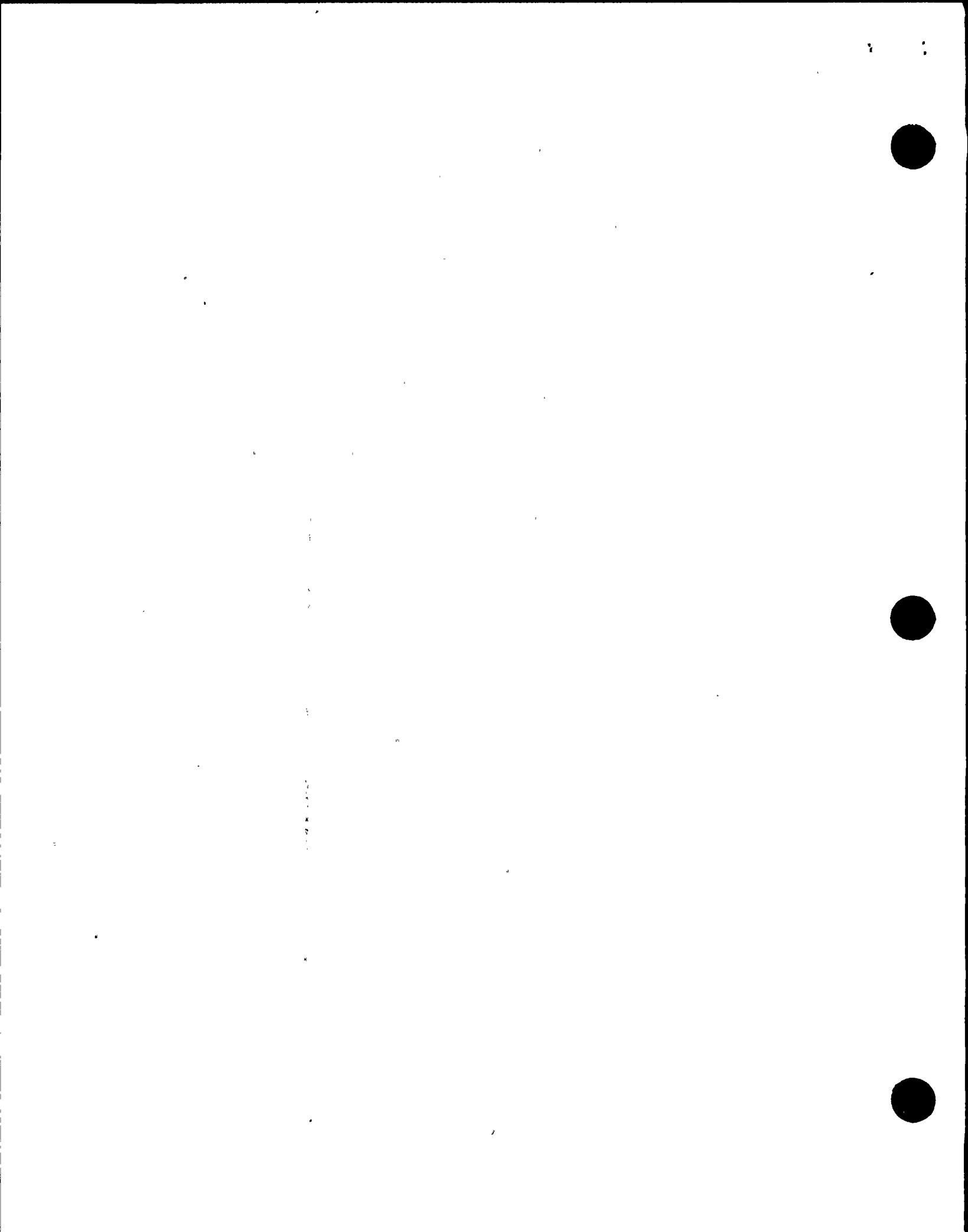

2.8 DETERMINE BUS LOSS ANNUNCIATION

It is necessary when a bus loss occurs that the control room operating personnel are alerted to the fact. This step in the analysis determined what type of warning was relayed to the control room, i.e., annunciation or undervoltage relay triggering "control voltage lamps."

The identity of the alarm, indicator, or annunciator are shown in the appropriate column in Appendix A. Major bus annunciators are also identified on the "Bus system cascade chart" Figure 2.

2.9 REVIEW PLANT PROCEDURES TO VERIFY APPROPRIATE STEPS DURING BUS LOSS

This step must be accomplished as a result of this analysis report. WPPSS or their designated engineers should provide this review. The primary response is to restore power to the affected power bus(es). If this is not possible, then shifting to an alternate cooldown path is required.

2.10 MODIFY/AUGMENT PLANT PROCEDURES

If plant procedures require modification after the Paragraph 2.9 review, then WPPSS should make the necessary changes. When the "affects" column in Appendix A indicates that an alternate shutdown path is required, existing procedures or new supplemental procedures should be identified or prepared.

3.0 CONCLUSIONS

3.1 ALTERNATE SHUTDOWN PATHS

Analysis of the report information shows no situation where a single Bus Power Failure would prevent plant personnel from achieving a Reactor Cold Shutdown condition. This conclusion is based primarily on the analysis results as shown in Appendix "A", which delineates that no single bus supplies power to all three shutdown paths. In most cases, single buses provide power to systems that are active in only one shutdown path.

3.2 BUS FAILURE ANNUNCIATION

Bus failure of a major bus (i.e., 6.9 kV thru 480 Volt) is annunciated in the control room, thus giving the operator the knowledge that bus power is lost. The review and analysis of Appendix "A" and Figure 2 shows conclusively that control room personnel will have knowledge of individual bus or circuit failures.

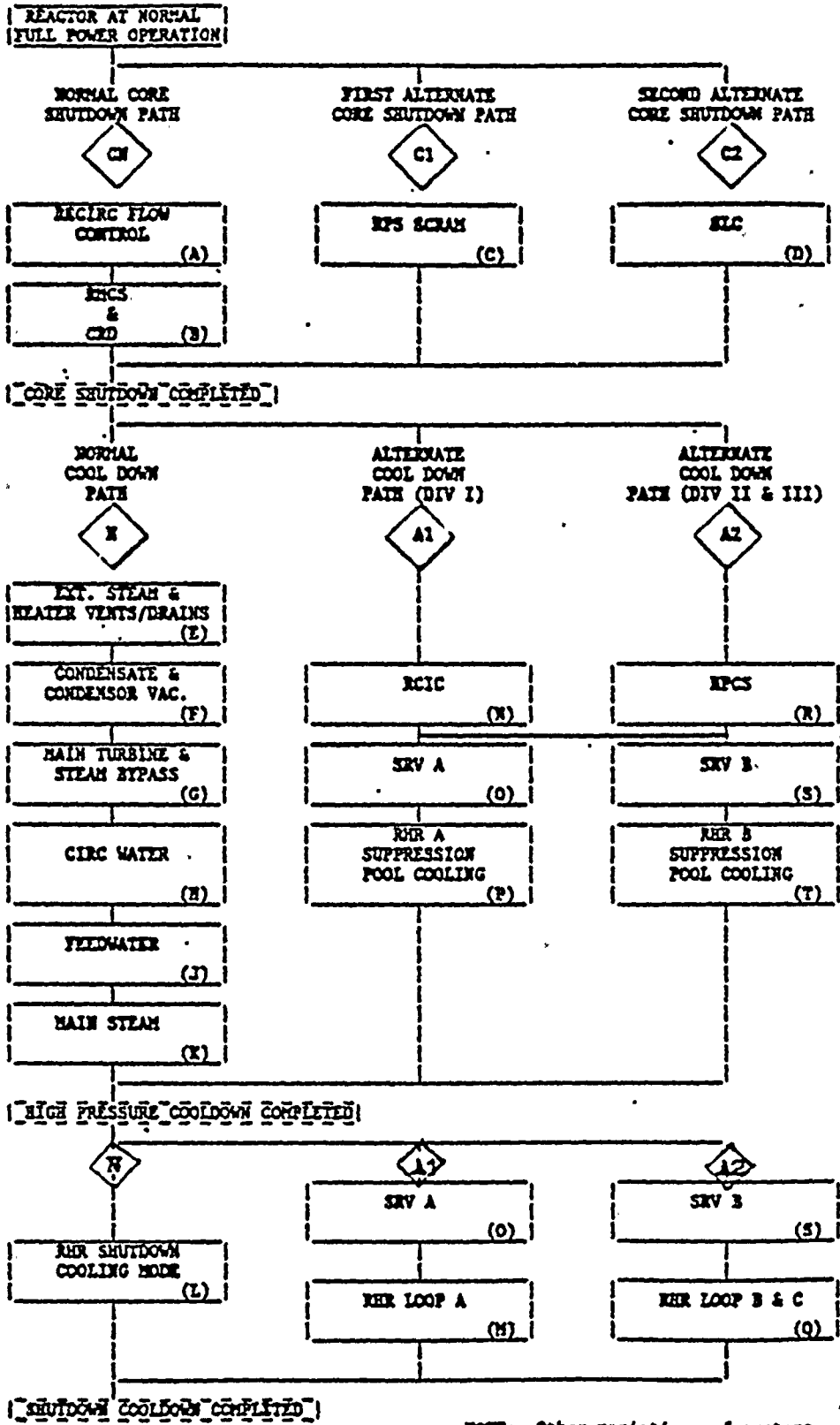

NOTE: Other variations of systems are possible using RHC (LPCI) ADS AND LPCS.

FIGURE 1 - COLD SHUTDOWN PATHS - WPP-2

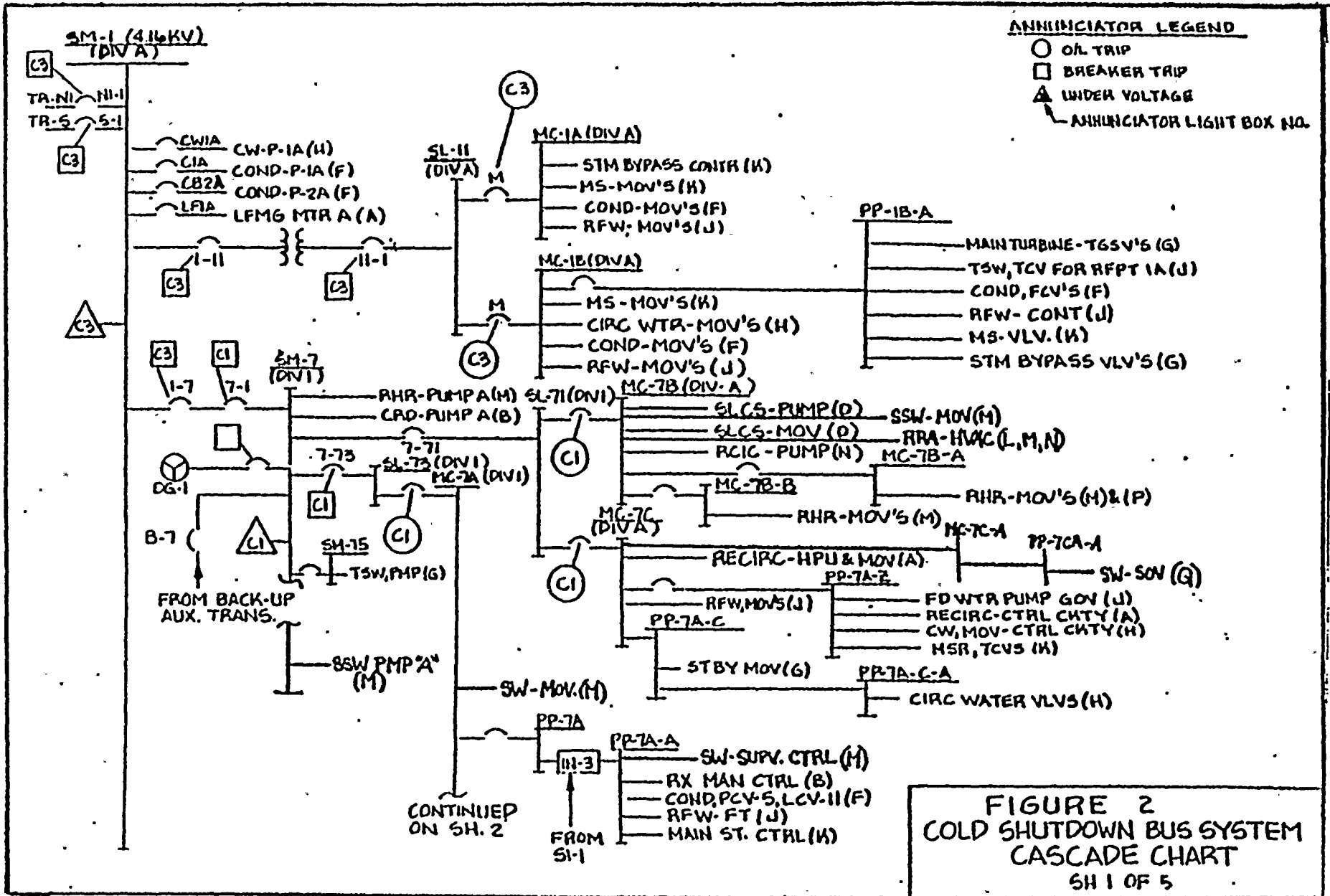

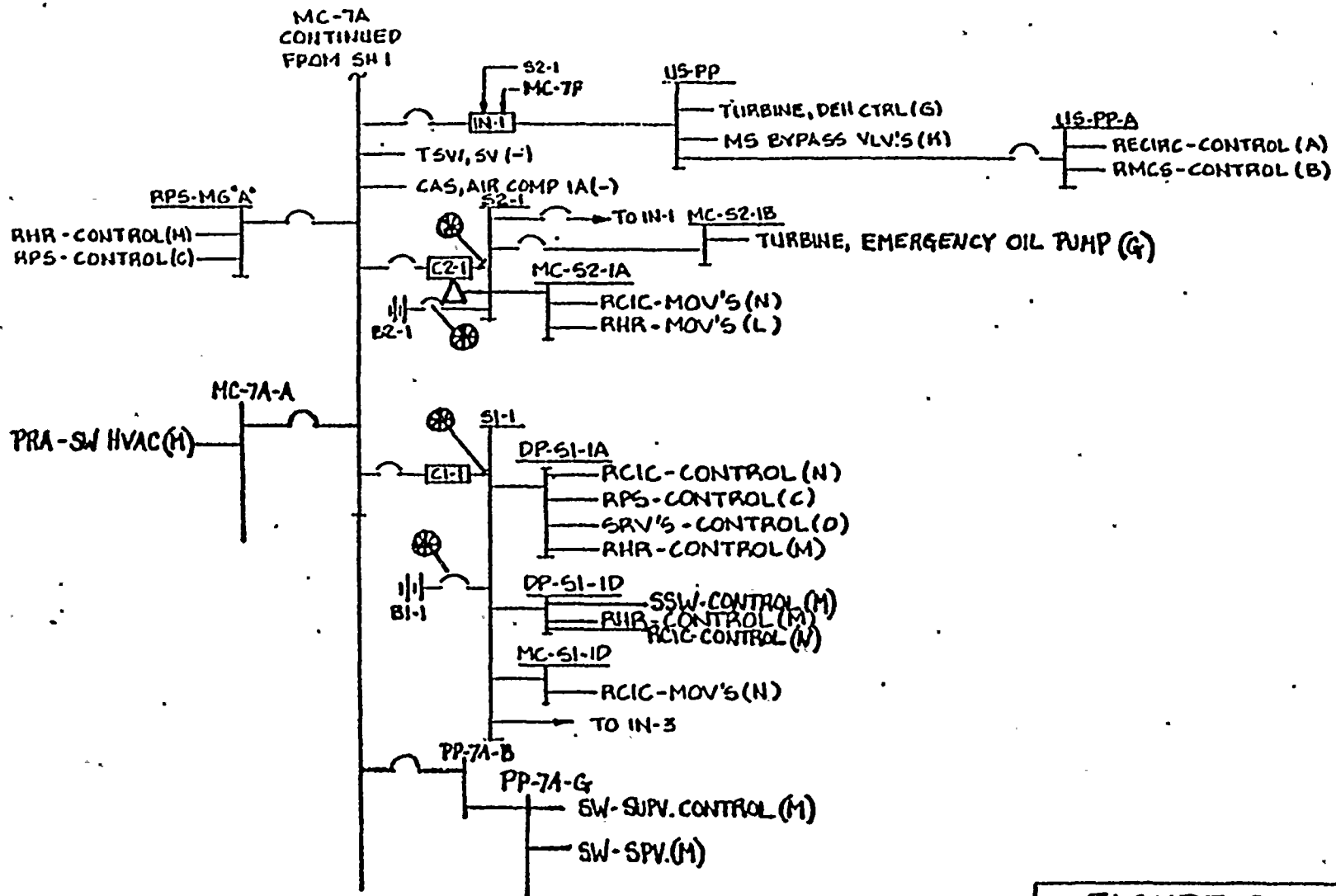

FIGURE 2
COLD SHUTDOWN SYS
SH. 2 OF 5

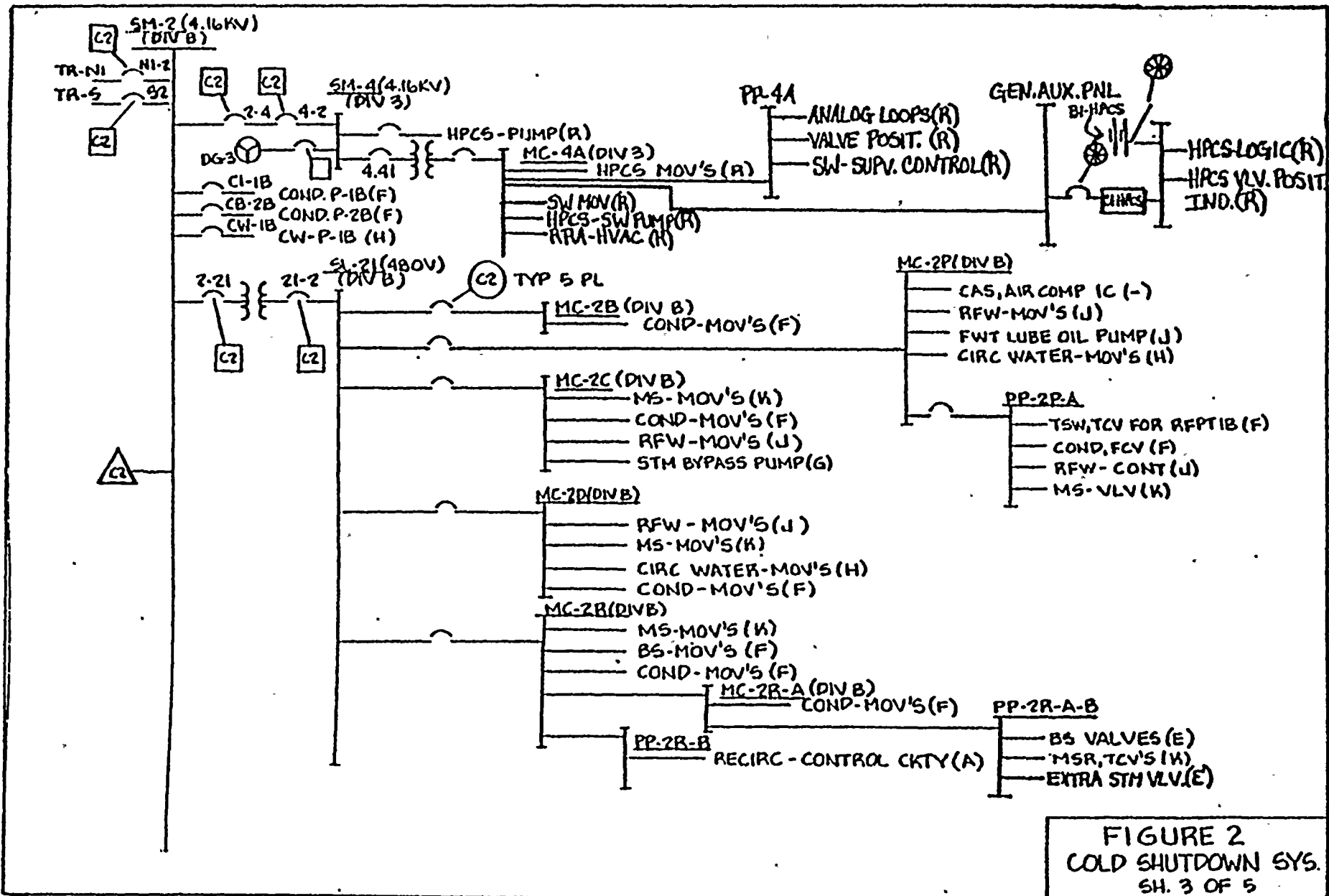

FIGURE 2
COLD SHUTDOWN SYS.
 SH. 3 OF 5

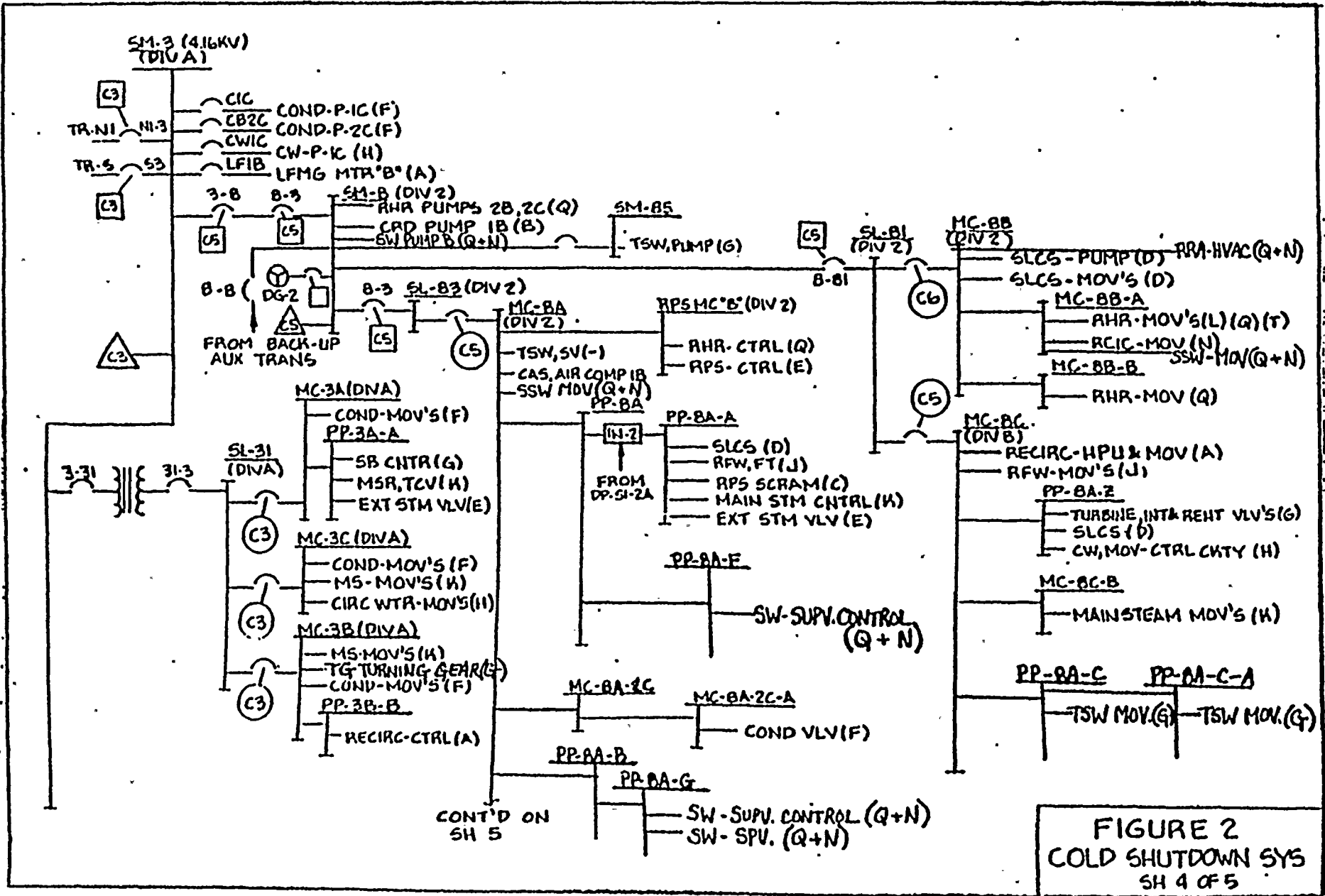

FIGURE 2
COLD SHUTDOWN SYS
 SH 4 OF 5

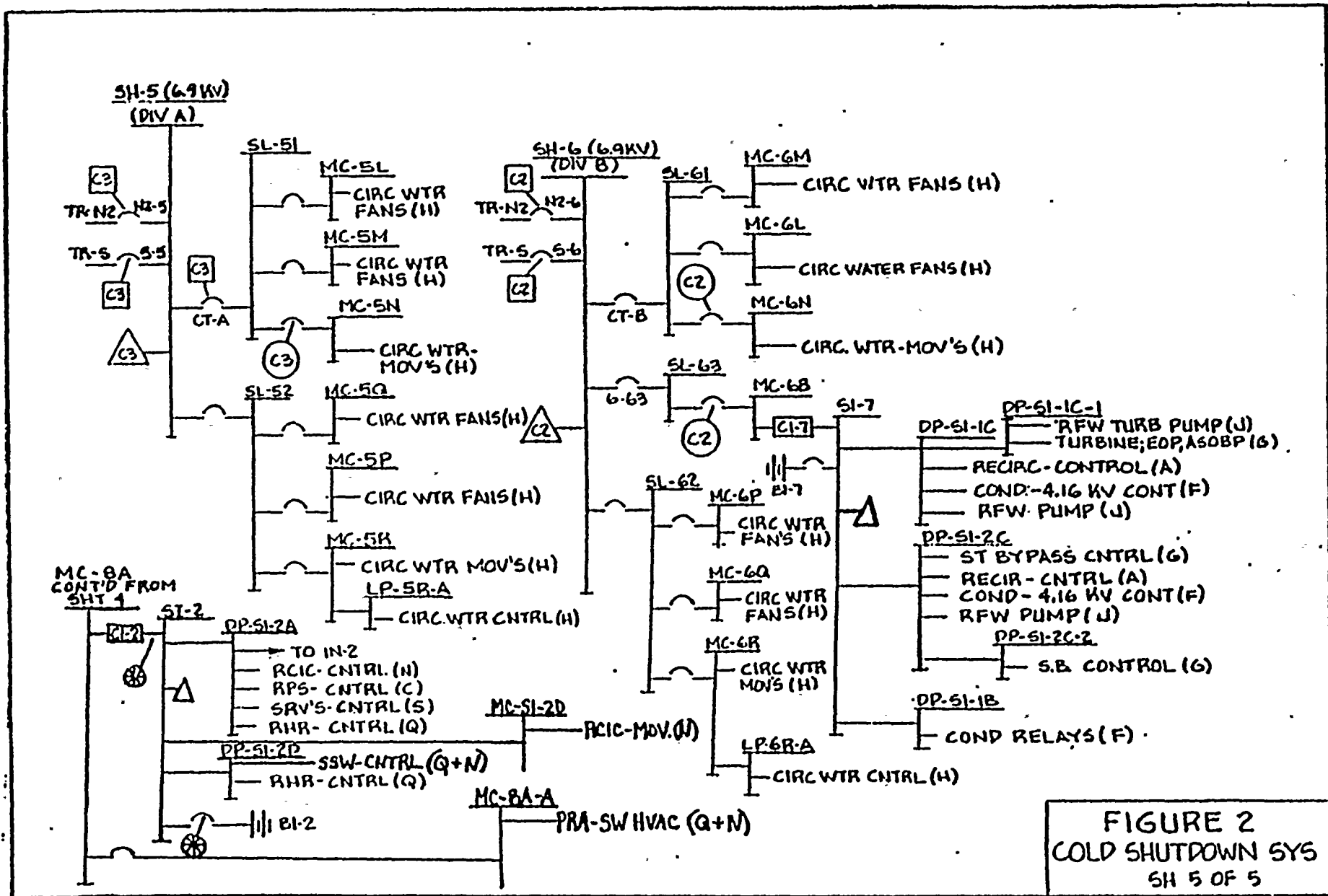

FIGURE 2
COLD SHUTDOWN SYS
SH 5 OF 5

APPENDIX A
WPPSS NUCLEAR PLANT NUMBER 2 (WNPP-2)
COLD SHUTDOWN POWER BUS ANALYSIS

NOTES:

- 1) THE LOSS OF BUS POWER IN THE A1 PATH OF AFFECTING COLD SHUTDOWN REQUIRED THE CONSIDERATION OF TRANSFERRING TO THE SECOND ALTERNATE PATH A2 . THIS CONSIDERATION IS OBVIOUSLY DEPENDENT UPON THE TIME SEQUENCE OF BUS POWER LOSS (I.E., IF THE A1 SYSTEM HAS BEEN USED AND DROPPED, THEN TRANSFER TO THE A2 PATH IS NOT NECESSARY).
- 2) THE COMBINATION OF A SINGLE BUS POWER LOSS THAT AFFECTS DEVICES IN TWO SHUTDOWN PATHS (I.E. N AND A1 OR CN AND C1) REQUIRES TRANSFERRING OF CONTROLS TO THE SECOND ALTERNATE SHUTDOWN PATH. (THIS IS NOT REQUIRED FOR FAILURE OF C1 AS THIS ROUTE IS FAIL SAFE ON LOSS OF POWER.)
- 3) THIS FEEDER BUS POWERS OTHER BUSES THAT POWER DEVICES IN ALTERNATE SHUTDOWN PATHS. TRANSFER OF THE SHUTDOWN MODE TO THE NEXT ALTERNATE PATH MUST BE ACCOMPLISHED IF BUS POWER CANNOT BE RE-ESTABLISHED.
- 4) LOSS OF A COMMON POWER BUS THAT AFFECTS A CORE SHUTDOWN PATH AND HEAT REMOVAL PATH REQUIRES A TRANSFER TO THE FIRST AVAILABLE ALTERNATE. SINCE BOTH PATHS ARE NOT REQUIRED SIMULTANEOUSLY, FURTHER ANALYSIS NOT NECESSARY.
- 5) THIS FEEDER BUS POWER OTHER BUSES THAT POWER DEVICES IN THE SAME COLD SHUTDOWN PATHS. TRANSFER TO THE FIRST ALTERNATE SHUTDOWN PATH IS NECESSARY.
- 6) THE LOSS OF POSITION INDICATION LAMPS FOR SEVERAL MOVES OR DEVICES IS INDICATIVE OF A POWER BUS FAILURE. UPON FAILURE OF ONE SET OF INDICATION LAMPS A REVIEW OF ADJACENT LAMPS WILL INDICATE POWER FAILURE OF THE RESPECTIVE BUS.
- 7) TRANSFER MUST BE INITIATED TO A2 .

<u>POWER BUS NUMBER</u>	<u>ESSENTIALITY CODE</u>	<u>DIV</u>	<u>AFFECTED DEVICES</u>	<u>PATH CODE</u>	<u>ANN. TRIP OR LOSS OF CNTL. SIGNAL</u>	<u>AFFECT ON CONTINUING IN EXISTING SHUTDOWN MODE</u>
PP-1B-A	NON-ESS	A	AR - SPV'S (F) TURBINE - TURN GEAR (G) FEEDWATER - CONTROL (J) COND-FCV'S (F) H.S. - VALVE (K) TSW, TCV FOR REPT 1A (J)	N	NOTE 6	MUST TRANSFER TO ALTERNATE COOLDOWN PATH A1 OR A2
HC-1B	NON-ESS	A	CIRC. WATER - MOVS (H) COND - MOVS (F) H.S. - MOVS (K) FEED TO PP-1B-A	N	O/L TRIP ANN. NOTE 6	NOTE 5.
HC-1A	NON-ESS	A	TG-OIL PUMPS, EHP, EX (G) HS-MOVS (K) COND-MOVS (F) RFW -MOVS (J)	N	O/L TRIP ANN. NOTE 6	MUST TRANSFER TO ALTERNATE COOLDOWN PATH A1 OR A2
SL-11	NON-ESS	A	FEED TO HCC'S HC-1A & HC-1B AND PANEL PP-1B-A	-	BKR TRIP ANN.	NOTE 5
HC-7B-A	ESS-1E	1	RHR MOVS (M) & (P) & (L) LOSS OF PWR TO HIGH-LOW PRESS PERMISSIVE	A1 N	MOV NETWORK PWR LOSS/OL LIGHT. RHR/LPCS OUT OF SERV. ANN.	NOTE 7.
HC-7B-B	ESS-1E	1	RHR MOVS (M) LOSS OF PWR TO HIGH-LOW PRESS PERMISSIVE	A1 N	RHR/LPCS OUT OF SERV. ANN.	NOTE 7

POWER BUS NUMBER	ESSENTIALITY CODE	DIV	AFFECTED DEVICES	PATH CODE	ANN. TRIP OR LOSS OF CNTL. SIGNAL	AFFECT ON CONTINUING IN EXISTING SHUTDOWN MODE
HC-7B	ESS-1E	1	SSW-MOV'S (H) SLCS PUMPS & MOV'S (D) RRA-INVAC-RCIC, RHR (L,H,N) RCIC-PUMP (N) FEED TO BUSES HC-7B-A & HC-7B-B	N C2 A1	O/L TRIP ANN. MOV NETWORK PWR LOSS/OL LIGHT. RHR/LPCS OUT OF SERV. ANN. "RHR PUMP 2A ROOM INVAC OUT-OF SERVICE" "RRA-FN-12 PWR LOSS" "RHR PUMP RH-2 RRA-FC-2 TRIP" "RCIC DIV. 1 OUT- OF-SERVICE" "DC MCC-RH ADA-AD-12 INLET DAMPER CLOSE"	NOTE 4
PP-7A-C-A		A	TSW-MOV (G) CIRC WTR VALVES (H)	N	NOTE 6.	NOT REQUIRED
PP-7A-C		A	TSW-MOV (G) FEED TO PP-7A-C-A	N	NOTE 6	NOTE 5.
PP-7A-Z	NON-ESS	A	RECIRC CONTROL (A) FWCS, PUMP GOV. (J) CIRC WTR FAN CONTROL (H) MAIN STEAM CONTROL (K)	CN N	P603 ANN. RFP B AT CONSTANT SPEED RPV HIGH WATER LEVEL TRIP RECIRC FCV'S LOCKUP FCV'S MOTION INHIBIT ALARM RFW TURBINE A STOPPED MASTER CNTLR OUTPUT SIGNAL ABNORMAL. FLUX CNTLR OUTPUT SIGNAL ABNORMAL NOTE 6	MUST TRANSFER TO ALTERNATE PATH C1 AND SEE NOTE 4.

POWER BUS NUMBER	ESSENTIALITY CODE	DIV	AFFECTED DEVICES	PATH CODE	ANN. TRIP OR LOSS OF CNTL. SIGNAL	AFFECT ON CONTINUING IN EXISTING SHUTDOWN MODE
PP-7CA-A	NON-ESS	A	SW-SV (N) FROM RRA-FC-6	A1	NOTE 6	NONE, OPERATION IS AVAILABLE FROM REMOTE SHUTDOWN PANEL IF REQUIRED.
HC-7C	NON-ESS	A	RECIRC HYD. PWR. UNITS (A) REACTOR FW MOVES (J) FEED TO PANEL PP-7A-Z AND PP-7A-C	CN H	P603 ANN. RFP B AT CONSTANT SPEED RPV HIGH WATER LEVEL TRIP RECIRC FCV'S LOCKUP FCV'S MOTION INHIBIT ALARM RFW TURBINE A STOPPED MASTER CNTLR OUTPUT SIGNAL ABNORMAL. FLUX CNTLR OUTPUT SIGNAL ABNORMAL NOTE 6	NOTE 4
SL-71	ESS-1E	1	FEED TO THE HC-7C & HC-7B	-	BKR TRIP ANN.	NOTES 2 AND 3
C72-P001 (HG 'A') BUS A	RPS A	A	RPS CONTROL (C) RHR CONTROL	C1 H	REACTOR $\frac{1}{2}$ SCRAM & ANNUNCIATION	LOSS OF RPS (C1 PATH) CREATES FAIL SAFE CONDITION. TRANSFER TO A1 OR A2.
PP-7A-A	ESS-1E	1	RX MANUAL CONTROL (B) CONDENSATE VALVES (F) RX FEEDWATER (J) AR CONTROL (K) SW - SUPR CONTROL (M) SSW - SPURP CONTROL (M)	CN H H A1 A1	LOSS OF VOLTAGE IND FOR PP-7A-A ON BOARD - C "SSW "A"-SVPV SYST TROUBLE" "SSW "A"-OUT-OF- SERVICE" "SSW PP HOUSE A, PRA-FN-A LOW FLOW"	AFFECTS ROD BLOCK; C1 SHUT- DOWN PATH SHOULD BE INITIATED. TRANSFER TO A2 . NOTE 6.

<u>POWER BUS NUMBER</u>	<u>ESSENTIALITY CODE</u>	<u>DIV</u>	<u>AFFECTED DEVICES</u>	<u>PATH CODE</u>	<u>ANN. TRIP OR LOSS OF CNTL. SIGNAL</u>	<u>AFFECT ON CONTINUING IN EXISTING SHUTDOWN MODE</u>
PP-7A	ESS-1E	1	FEED TO INVERTER THAT FEEDS PP-7A-A (ALSO FED FROM S1-1)	-		NOTE 3.
US-PP-A	NON-ESS	A	RECIRC FLOW CONTROL (A) RMCS CONTROL (B)	CN CN	NONE, HOWEVER ROD BLOCK INITIATED	LOSS OF BUS REQUIRES TRANSFER- RING TO C1 ALTERNATE PATH
US-PP	NON-ESS	A	TURBINE, DEH CONTROL CKT (G) MS, BYPASS VALVE CONT (K) FEED TO US-PP-A	N N	LOSS OF VOLTAGE IND ON BOARD-C. LOSS OF DIGITAL CONTROL	UNABLE TO COOLDOWN BY BLEEDING STEAM, MUST TRANSFER TO A1 OR A2 .
DP-S1-1A	ESS-1E	1	RPS BACKUP SCRAM VALVE (C) RECIRC PUMP TRIP CKT (C) RCIC CONTROL (N) SRV CONTROL (O) RHR CONTROL (M)	C1 A1 A1 A1	P601 RCIC PWR FAILURE LIGHT, RHR LOGIC A PWR FAILURE ANN. LPCS/RHR A PWR FAILURE LIGHT RHR/LPCS OUT OF SERV. ANN. RCIC DIV 1 OUT OF SERV. ANN.	NOTE 1.

<u>POWER BUS NUMBER</u>	<u>ESSENTIALITY CODE</u>	<u>DIV</u>	<u>AFFECTED DEVICES</u>	<u>PATH CODE</u>	<u>ANN. TRIP OR LOSS OF CNTRL. SIGNAL</u>	<u>AFFECT ON CONTINUING IN EXISTING SHUTDOWN MODE</u>
DP-S1-1D	ESS-1E	1	SSW-CONTROL (H) RHR CONTROL (H) RCIC CONTROL (N)	A1	CB-SSW-1A OUT OF SERV. SSW A OUT OF SERVICE CB-RHR 2A OUT OF SERV. LIGHT RHR A/LPCS OUT OF SERV. ANN. P601 MOV NETWORK PWR LOSS LIGHT RCIC DIV 1 OUT OF SERV. ANN. LOSS OF P601 RCIC VALVE AND PUMP IND LIGHTS ADS A/C PWR FAILURE LIGHT ADS A/C OUT OF SERV. ANN. P601 LOSS OF ADS VALVE IND LIGHTS	NOTE 1
MC-S1-1D	ESS-1E	1	RCIC MOVS (N)	A1	NOTE 6. P601 MOV NETWORK PWR LOSS LIGHT RCIC DIV. 1 OUT OF SERV. ANN. LOSS OF P601 RCIC VALVE AND PUMP IND. LIGHTS	NOTE 1.
S1-1	ESS-1E	1	FEED TO THE PRIOR 3 PANELS DP-S1-1A, DP-S1-1D, MC-S1-1D	-	UNDERVOLTAGE ANN.	NOTE 3.
MC-S2-1A	ESS-1E	1	RCIC-MOVS (N) RHR-MOVS (L)	A1 N	NOTE 6.	NOTE 2.
MC-S2-1B	NON-ESS	A	TG EMERG. OIL PUMPS (G)	N	NOTE 6.	NONE.

POWER BUS NUMBER	ESSENTIALITY CODE	DIV	AFFECTED DEVICES	PATH CODE	ANN. TRIP OR LOSS OF CNTL. SIGNAL	AFFECT ON CONTINUING IN EXISTING SHUTDOWN MODE
S2-1	ESS-1E	1	FEED TO PRIOR 2 MCCS MC-S2-1A, MC-S2-1B & IN-1	-	UNDervOLTAGE ANN.	NOTE 3.
HC-7A-A	ESS-1E	1	PRA-FN-1A, (H)	A1	PRA-FN-1A PWR LOSS SSW A OUT OF SERVICE "STDBY-SW-A SUPV SYST TROUBLE" NOTE 6	NOTE 1.
PP-7A-G	ESS-1E	1	SW-SUPV CONTROL (H) SW-SPV (H)	A1	SUPV SYS TROUBLE SSW A OUT-OF-SERVICE "STDBY SW 'A' SUPV SYST TROUBLE"	NOTE 1.
HC-7A	ESS-1E	1	SSW-MOV (H) CAS, AIR COMP (-) TSW, SV (-) FEED TO HC-7A-A, PP-7A-G PP-7A, S2-1, S1-1, IN-1	A1	"SSW A OUT-OF-SERVICE "MOV NETWORK PWR LOSS/OL" NOTE 6 O/L TRIP ANN.	NOTE 1.
SL-73	ESS-1E	1	FEED TO PRIOR MCC-HC-7A	-	BKR TRIP ANN.	NOTE 1.
SH-75	NON-ESS	A	TSW, PUMP (G)	H	BKR TRIP ANN.	NONE.
SH-7	ESS-1E	1	RHR PUMP 'A' (H) SSW PUMP 'A' (H) CRD PUMP 'A' (B) FEED TO LOAD CENTERS SL-71/ SL-73 AND SH-75	A1 CN	SH7 BUS TRIP AND UNDervOLTAGE ANN. SH-8 UNDervOLTAGE ANN.	NOTE 4. TRANSFER TO C1 AND A2
SH-1	ESS-1E	A	CW PUMP (H) COND PUMP (F) COND. BOOSTER PUMP (F) LFHG MTR 'A' (A) FEED TO SWITCH GEAR SH-7/SL-11	H CN	UNDervOLTAGE BKR TRIP ANN. BKR TRIP ANN.	NOTE 4. TRANSFER TO A1 OR A2 NOTE 3.

POWER BUS NUMBER	ESSENTIALITY CODE	DIV	AFFECTED DEVICES	PATH CODE	ANN. TRIP OR LOSS OF CNTL. SIGNAL	AFFECT ON CONTINUING IN EXISTING SHUTDOWN MODE
PP-4A	ESS-1E	3	SSW-SUPV CONTROL (R) HPCS CONTROL (R)	A2	P601 LOSS OF VALVE POSITION LIGHTS	NOTE 1.
GEN & ENG AUX PANEL	ESS-1E	3	HPCS CONTROL (R)	A2	LOSS OF GEN. INDICATORS.	NONE.
HC-4A	ESS-1E	3	HPCS-SW PUMP (R) HPCS MOVS (R) RRA-IVAC (R) FEED TO PP4A AND GEN. AUX. PNL.	A2	NOTE 6 P601 LOSS OF VALVE POSITION LIGHTS "HPCS SW OUT-OF-SER- VICE" "HPCS OUT-OF-SERVICE" "HPCS PUMP ROOM IVAC OUT-OF-SERVICE" "HPCS PUMP RH-6 RRA-FC-4 TRIP"	NOTE 1.
SM-4	ESS-1E	3	HPCS PUMP (R) FEED TO HC-4A	A2 -	TWO BKR TRIP ANN.	NOTE 1.
PP-2RA-B	NON-ESS	B	BS, NRV'S (E) MS, TCVS (K) EXTR STH VALVE (E)	N	NOTE 6	NONE.
HC-2R-A	NON-ESS	B	COND. MOVS (F) FEED TO PP-2RA-B	N -	NOTE 6	NON, ALL MOVS FAIL AS IS.
PP-2R-B	NON-ESS	B	RECIRC CONTROL (A)	CN	SYS B DRYWELL HIGH PRESS INTLK. FLOW CONTROL VALVE B HYD PWR UNIT STARTUP INHIBITED	MUST TRANSFER TO C1 ALTERNATE PATH
HC-2R	NON-ESS	B	AR MOV (F) COND MOVS (F) M.S. MOVS (K) FEED TO PP-2R-B AND HC-2R-A	N -	O/L TRIP NOTE 6 NOTE 6	TRANSFER TO C1

POWER BUS NUMBER	ESSENTIALITY CODE	DIV	AFFECTED DEVICES	PATH CODE	ANN. TRIP OR LOSS OF CNTRL. SIGNAL	AFFECT ON CONTINUING IN EXISTING SHUTDOWN MODE
PP-2P-A	NON-ESS	B	AR-SPV'S (F) H.S. VLV (K) RFW-TURBINE CONTROL (J) COND-FCV (F) TSW-TCV FOR REPT-1B (J)	N	NOTE 6	LOSS OF RFP-B MAY RESULT IN NEED TO SHIFT TO ALTERNATE PATH A1 OR A2
MC-2P	NON-ESS	B	CAS, AIR COMPRESSORS & VLV (-) FEEDWATER PUMP TURNING GEAR & MOVS (J) CIRC WATER MOVS (H) FEED TO PP-2P-A	N	O/L TRIP ANN.	OTHER COMP. OPERABLE. LOSS OF 1 PUMP HAS NO EFFECT. MOVS FAIL AS IS. NO TRANSFER REQUIRED
MC-2D	NON-ESS	B	AR-EX (F) CIRC WATER MOVS (H) COND. MOVS (F) RFW MOVS (J) H.S. MOVS (K) & (F)	N	O/L TRIP ANN. AND NOTE 6.	NONE.
MC-2C	NON-ESS	B	H.S. MOVS (K) COND. MOVS (F) RFW MOVS (J) TG-EHP (G)	N	O/L TRIP ANN. NOTE 6	NONE.
MC-2B	NON-ESS	B	COND. MOVS (F)	N	NOTE 6 O/L TRIP ANN.	NONE.
SL-21	NON-ESS	B	FEED TO MC-2R, MC-2P, MC-2D, MC-2C AND MC-2B.	-	TWO BKR TRIP	LOSS OF RFP B MAY RESULT IN NEED TO SHIFT TO ALTERNATE PATH A1 OR A2
SH-2	NON-ESS	B	COND. PUMP 'B' (F) COND. BOOSTER PUMP (F) C.W. PUMP (H) FEED TO SH-4 AND SL-21	N	TWO BKR TRIP UNDER- VOLTAGE	TRANSFER TO A1 OR A2
MC-8C-D	NON-ESS	B	MAINSTEAM-MOVS (K)	N	NOTE 6	NONE.

POWER BUS NUMBER	ESSENTIALITY CODE	DIV	AFFECTED DEVICES	PATH CODE	ANN. TRIP OR LOSS OF CNTL. SIGNAL	AFFECT ON CONTINUING IN EXISTING SHUTDOWN MODE
PP-8A-Z	NON-ESS	B	SLCS ALARMS AND INDICATORS (D) RFW TURBINE B TRIP (J) TURBINE VALVES (G) CW, FANS MOV-CONTROL (H)	C2	RFT B TRIP ANN. BOARD H LOSS OF FANS STATUS LIGHTS	DIV. A ALTERNATE RFW PUMP AND VALVE CONTROLS IS USED.
				N	BOARD B LOSS OF VALVE POSITION IND.	
PP-8A-C-A	NON-ESS	B	TSW MOV (G)	N	NOTE 6.	NONE.
PP-8A-C	NON-ESS	B	TSW-MOV (G)	N	NOTE 6.	NONE.
MC-8C	NON-ESS	B	RECIRC HPU & MOV (A) RFW, MOV (J) FEED TO MC-8C-B, PP-8A-C, PP-8A-Z AND PP-8A-C-A	CH	O/L TRIP ANN.	TRANSFER TO ALTERNATE PATH C1 MAY NOT BE NEEDED.
				N		
				-	NOTE 6	
MC-8B-B	ESS-1E	2	RHR MOV (Q)	A2	P601 LOSS OF VALVES POSITION IND.	SYSTEM PREPARATION FOR N PATH. NO TRANSFER REQUIRED. A2 ARE 'B' VALVE. ALTER- NATE SHUTDOWN PATH IS VIA 'A' VALVES.
MC-8B-A	ESS-1E	2	RHR MOV (L), (Q) AND (T) SSW-MOV (Q) (H) RCIC MOV (H)	A2	RCIC DIV. 2 OUT OF SERV. ANN.	USE HPCS THEN TRANSFER TO A1
				A1	NOTE 6 MOV NETWORK PWR LOSS/OL. RHR B/C OUT OF SERV. ANN. "RHR 2B/C PUMP ROOM OUT-OF-SERVICE"	

POWER BUS NUMBER	ESSENTIALITY CODE	DIV	AFFECTED DEVICES	PATH CODE	ANN. TRIP OR LOSS OF CNTL. SIGNAL	AFFECT ON CONTINUING IN EXISTING SHUTDOWN MODE
MC-8B	ESS-1E	2	SLCS PUMP AND MOVS (D) RRA-HVAC (Q) (N) FEED TO MC-8B-B & MC-8B-A	C2 A1 A2	O/L TRIP ANN. "RCIC PUMP RM-3 RRA-FC-6 TRIP" RCIC PUMP RM HVAC OUT-OF-SERVICE "RCIC DIV 2 OUT- OF-SERVICE" "RHR PUMP RM-1/4 RRA-FC-3/1 TRIP" "RHR B/C PUMP RM HVAC OUT-OF- SERVICE"	USE HPCS, THEN TRANSFER TO A1 NOTE 3.
SL-81	ESS-1E	2	FEED TO MCC'S MC-8C/MC-8B	-	BKR TRIP ANN.	
DP-S1-2D	ESS-1E	2	RHR CONTROL (Q) SSW-CONTROL (Q) (N)	A2 A1 A2	CB-RHR 2B OUT OF SERV. LIGHT CB-RHR 2C OUT OF SERV. LIGHT RHR B/C OUT OF SERV. ANN. CB-SWIB OUT OF SERV. CB-SSW-B OUT OF SERV.	USE HPCS THEN TRANSFER BACK TO A1
DP-S1-2A	ESS-1E	2	RCIC CONTROL (N) RPS CONTROL (C) SRV CONTROL (S) RHR CONTROL (Q)	A1 C1 A2 A2	LOSS OF RHR LOGIC ALARM B/C LOGIC PWR FAILURE LIGHT. RCIC DIV. 2 OUT OF SERV. ANN. RHR B/C OUT OF SERV. ANN.	NOTE 1 AND 2.
MC-S1-2D	ESS-1E	2	RCIC-MOV (N)	A1	P601 MOV NETWORK PWR LOSS LIGHT. RCIC DIV. 1 OUT OF SERV. ANN.	NONE.

POWER BUS NUMBER	ESSENTIALITY CODE	DIV	AFFECTED DEVICES	PATH CODE	ANN. TRIP OR LOSS OF CNTRL. SIGNAL	AFFECT ON CONTINUING IN EXISTING SHUTDOWN MODE
S1-2	ESS-1E	2	FEED TO MC-S1-2D, DP-S1-2D AND DP-S1-2A	-	UNDERVOLTAGE ANN.	NOTE 3.
PP-8A-A	ESS-1E	2	SLCS INDICATION (D)	C2		POTENTIAL TRANSFER TO ALTER- MATE HEAT REMOVAL PATH.
			RPS INDICATION (C)	C1		
			AIR REMOVAL CONTROL (K)	N		
			EXTRACT. STEAM PT (E) RFW, FT (J)			
PP-8A-F	ESS-1E	2	SW-SUPV CONTROL (Q) (N)	A1	SSW B SUPV SYSTEM TROUBLE IND.	USE HPCS THEN TRANSFER BACK TO A1 .
				A2	SSW B OUT-OF-SERV. IND. "SSWPP HOUSE B PRA-FN-1B LOW FLOW"	
PP-8A	ESS-1E	2	FEED TO PP-8A-F AND INVERTER TO PP-8A-A	-		NOTE 2.
C72-P001 BUS B	ESS-1E	B	RHR CONTROL (Q) (L)	N	REACTOR 1/2 SCRAM AND ANNUNCIATION	LOSS OF RPS C1 PATH CREATES FAIL SAFE CONDITION. TRANSFER TO A1 OR A2
			RPS CONTROL (C)	C1		
PP-8A-2C-A	NON-ESS	B	CONDENSATE VALVE (F)	N		NONE.
MC-8A-2C	NON-ESS	B	FEED TO PANEL PP-8A-2C-A	-		NONE.
PP-8A-G	ESS-1E	2	SW-SUPV CONTROL (Q) (N)	A1 A2	"STDBY SW-"B"-SUPV SYST TROUBLE"	USE HPCS OR RCIC THEN TRANSFER TO A1 OR N .
			SW-SPV (Q) (N)	A1 A2	SSW B OUT-OF-SERV.	

POWER BUS NUMBER	ESSENTIALITY CODE	DIV	AFFECTED DEVICES	PATH CODE	ANN. TRIP OR LOSS OF CNTRL. SIGNAL	AFFECT ON CONTINUING IN EXISTING SHUTDOWN MODE
HC-8A-A	ESS-1E	2	PRA-SW HVAC (Q) (N)	A1 A2 A2	PRA-FN-1B PWR LOSS. SSW B OUT OF SERVICE.	USE HPCS OR RCIC THEN TRANSFER TO A1 OR N .
HC-8A	ESS-1E	2	TSW, SV (-) CAS, AIR COMP. 1B (-) SSW MOV (Q) (N) FEED TO PP-8A, HC-8A-2C, PP-8A-G, AND HC-8A-A	A1 A2	MOV NETWORK PWR LOSS/OL. SSW B OUT-OF-SERV. IND. O/L TRIP ANN.	USE HPCS THEN TRANSFER TO A1 . NOTE 3
SL-83	ESS-1E	2	FEED TO PRIOR PANEL	-	BKR TRIP ANN.	NOTE 3.
SH-85	NON-ESS	B	TSW, PUMP (G)	N	BKR TRIP ANN.	NONE, BACK-UP BY OTHER PUMP.
SH-8	ESS-1E	2	RHR PUMPS 2B, 2C (Q) CRD PUMP 1B (B) FEED TO SL-81, SL-83 & SH-85 SSW PUMP 1B	A2 CN	TWO BKR TRIP AND UNDERVOLTAGE ANN.	NOTE 4. NOTE 3.
PP-3B-B	NON-ESS	A	RECIRC CONTROL (A)	CN	SYS A HIGH DRYWELL PRESS INTLK IND. FLOW CONTROL VALVE A HYD PWR UNIT STARTUP INHIBIT VALVE A SERVO AMP INPUT CNTRL SIGNAL ABNORMAL	POTENTIAL REACTOR SCRAM.
HC-3B	NON-ESS	A	H.S. MOVS (K) T.G. TURNING GEAR (G) AR MOVS (F) FEED TO PP-3B-B	N -	O/L TRIP ANN. NOTE 6	NOT ABLE TO USE N PATH MUST GO TO ALTERNATE SHUTDOWN
HC-3C	NON-ESS	A	CIRC. WATER MOVS (H) MS MOVS (K) CONDENSATE MOVS (F)	N	O/L TRIP ANN NOTE 6	NONE.

<u>POWER BUS NUMBER</u>	<u>ESSENTIALITY CODE</u>	<u>DIV</u>	<u>AFFECTED DEVICES</u>	<u>PATH CODE</u>	<u>ANN. TRIP OR LOSS OF CNTL. SIGNAL</u>	<u>AFFECT ON CONTINUING IN EXISTING SHUTDOWN MODE</u>
PP-3A-A	NON-ESS	A	TSW, HD CONTROL (G) EXTRACTION STM. VALVES (E) MSR-TCV (K)	N	O/L TRIP ANN. NOTE 6	TRANSFER TO A1 OR A2
HC-3A	NON-ESS	A	COND. MOVS (F) FEED TO PP-3A-A	N	O/L TRIP ANN.	TRANSFER TO A1 OR A2
SL-31	NON-ESS	A	FEED TO HC-3A, HC-3B, HC-3C	-	TWO BKR TRIP	NOTE 5.
SM-3	NON-ESS	A	COND. PUMPS 1C AND 2C (F) CIRC WATER PUMP 1C (H) LFHG MOTOR 'B' (A) FEED TO SM-8 AND SL-31	N N CN -	TWO BKR TRIP UNDER- VOLTAGE ANNUNCIATION	TRANSFER TO ALTERNATE SHUTDOWN IS NECESSARY. LFHG 'A' IS BACKUP. NOTE 5.
HC-6L	NON-ESS	B	CIRC WATER FANS (H)	N	HIGH VIBRATION O/L TRIP ANN.	NONE.
HC-6N	NON-ESS	B	CIRC. WTR MOVS (H)	N		FAIL AS IS. NO TRANSFER REQUIRED.
HC-6H	NON-ESS	B	CIRC. WTR FANS (H)	N	HIGH VIBRATION O/L TRIP ANN.	NONE.
SL-61	NON-ESS	B	FEED TO HC-6N/6L & 6H	-	BKR TRIP ANN.	NOTE 5
DP-S1-1C-1	NON-ESS	A	TURBINE CONTROL, EOP, ASOBP (G) RFW TURB. PUMP (J)	N N	NOTE 6 OIL PUMPS O/L IND.	NONE.
DP-S1-1C	NON-ESS	A	RECIRC CONTROL (A) RFW PUMP (J) COND. CONTROL (F) FEED TO DP-S1-1C-1	CN N	RECIRC LFHG B TRANSFER DISABLED NOTE 6	TRANSFER TO A1 OR A2
DP-S1-2C-2	NON-ESS	B	STEAM BYPASS CONTROL (G)	N	NONE	ALTERNATE PATH A1 OR A2

POWER BUS NUMBER	ESSENTIALITY CODE	DIV	AFFECTED DEVICES	PATH CODE	ANN. TRIP OR LOSS OF CNTRL. SIGNAL	AFFECT ON CONTINUING IN EXISTING SHUTDOWN MODE
DP-S1-2C	NON-ESS	B	RECIRC CONTROL (A) COND. CONTROL (F) VOLTAGE REGULATOR CONTROL (G) RFB PUMP (J) FEED TO DP-S1-2C-2	CN N N N N	RECIRC LFHG A TRANSFER DISABLED NOTE 6. DEN CONTROL REG. REG. SUPPLY BKR OPEN	ALTERNATE PATH A1 OR A2
DP-S1-1B	NON-ESS	A	COND. RELAYS (F)	N		TRANSFER TO A1 OR A2 LOSS OF CONDENSER VACUUM
S1-7	NON-ESS	-	FEED TO PRIOR 5 BUSES	-	UNDERVOLTAGE ANN.	NOTE 4.
HC-6B	NON-ESS	B	FEED TO INVERTER C1-7 FEEDING S1-7 (PRIOR 5 BUSES)	-	O/L TRIP ANN.	NONE.
SL-63	NON-ESS	B	FEED TO HC-6B	-	BKR TRIP ANN.	NOTE 3.
HC-6P	NON-ESS	B	CIRC. WTR FANS (H)	N	HIGH VIBRATION O/L TRIP ANN.	OTHER HALF WILL CONTROL FROM 'A' BUSES BELOW.
HC-6Q	NON-ESS	B	CIRC. WTR - FANS (H)	N	HIGH VIBRATION O/L TRIP ANN.	OTHER HALF WILL CONTROL FROM 'A' BUSES BELOW
LP-6R-A	NON-ESS	B	CIRC. WTR CONTROL (H)	N	NOTE 6	OTHER HALF WILL CONTROL FROM 'A' BUSES BELOW
HC-6R	NON-ESS	B	CIRC. WTR MOVS (H) FEEDS LP-6R-A	N	BKR TRIP ANN.	OTHER HALF WILL CONTROL FROM 'A' BUSES BELOW
SL-62	NON-ESS	B	FEED TO HC-6R/6P & /Q	-	BKR TRIP ANN.	OTHER HALF WILL CONTROL FROM 'A' BUSES BELOW
SH-6	NON-ESS	B	FEED TO SL-61/SL-63 & SL-62	-	TWO BKR TRIP	OTHER HALF WILL CONTROL FROM 'A' BUSES BELOW

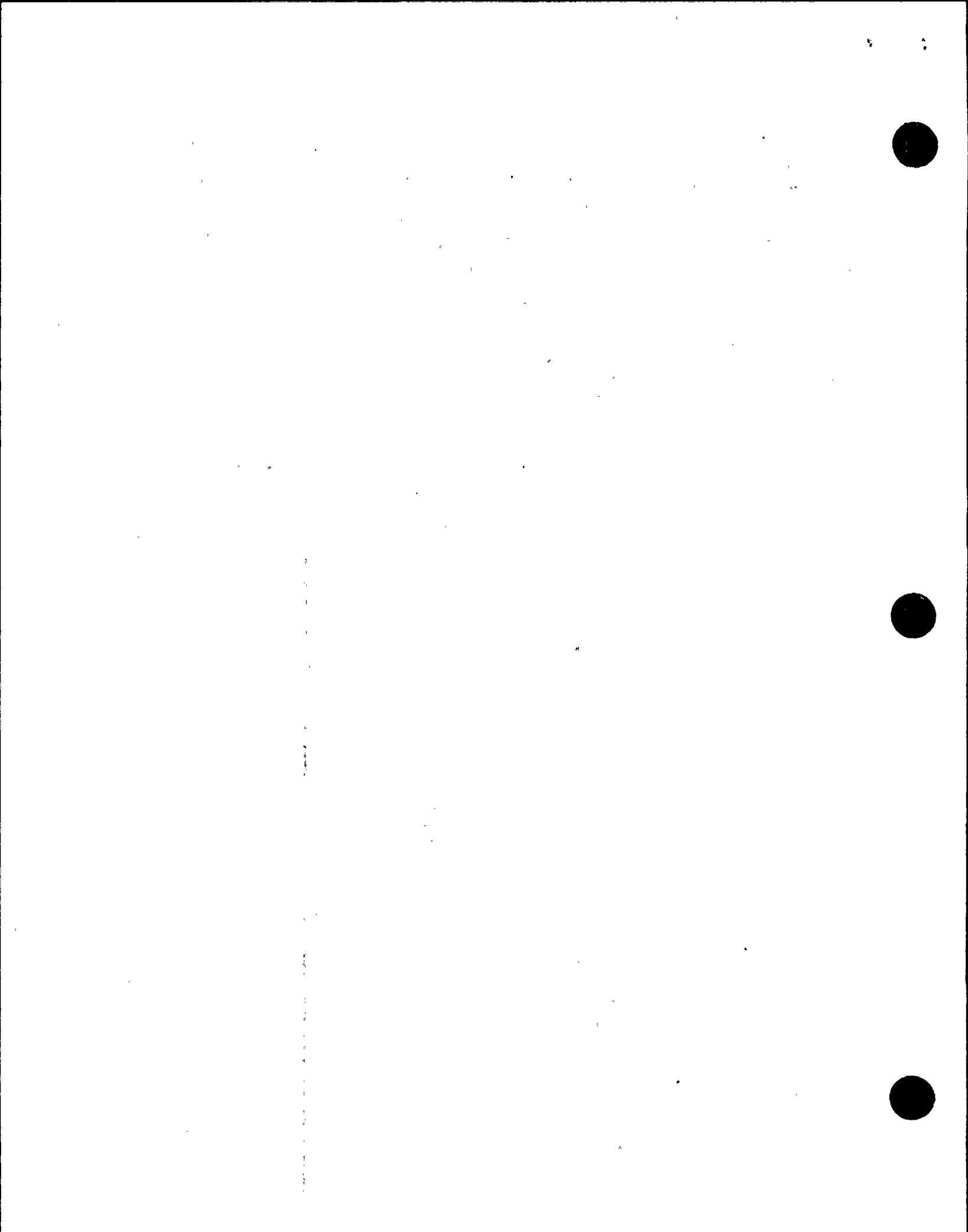

<u>POWER BUS NUMBER</u>	<u>ESSENTIALITY CODE</u>	<u>DIV</u>	<u>AFFECTED DEVICES</u>	<u>PATH CODE</u>	<u>ANN. TRIP OR LOSS OF CNTRL. SIGNAL</u>	<u>AFFECT ON CONTINUING IN EXISTING SHUTDOWN MODE</u>
MC-5N	NON-ESS	A	CIRC. WATER MOVS (H)	N	O/L TRIP ANN.	FAILS AS IS. NO TRANSFER REQUIRED. OTHER BUS DIVISION IS SUFFICIENT TO CONTROL CIRC. WATER.
MC-5L	NON-ESS	A	CIRC. WATER FANS (H)	N	HIGH VIBRATION O/L TRIP ANN. NOTE 6	FAILS AS IS. NO TRANSFER REQUIRED. OTHER BUS DIVISION IS SUFFICIENT TO CONTROL CIRC. WATER.
MC-5M	NON-ESS	A	CIRC. WATER FANS (H)	N	HIGH VIBRATION O/L TRIP ANN. NOTE 6	FAILS AS IS. NO TRANSFER REQUIRED. OTHER BUS DIVISION IS SUFFICIENT TO CONTROL CIRC. WATER.
SL-51	NON-ESS	A	FEED TO MC-5N/5L & 5M	-	BKR TRIP ANN.	FAILS AS IS. NO TRANSFER REQUIRED. OTHER BUS DIVISION IS SUFFICIENT TO CONTROL CIRC. WATER.
LP-5R-A	NON-ESS	A	CIRC. WATER CONTROL (H)	N	NOTE 6	FAILS AS IS. NO TRANSFER REQUIRED. OTHER BUS DIVISION IS SUFFICIENT TO CONTROL CIRC. WATER.
MC-5R	NON-ESS	A	CIRC. WATER MOVS (H)	N	BKR TRIP ANN.	FAILS AS IS. NO TRANSFER REQUIRED. OTHER BUS DIVISION IS SUFFICIENT TO CONTROL CIRC. WATER.
MC-5Q	NON-ESS	A	CIRC. WATER FANS (H)	N	HIGH VIBRATION O/L TRIP ANN.	FAILS AS IS. NO TRANSFER REQUIRED. OTHER BUS DIVISION IS SUFFICIENT TO CONTROL CIRC. WATER.

<u>POWER BUS NUMBER</u>	<u>ESSENTIALITY CODE</u>	<u>DIV</u>	<u>AFFECTED DEVICES</u>	<u>PATH CODE</u>	<u>ANN. TRIP OR LOSS OF CNTL. SIGNAL</u>	<u>AFFECT ON CONTINUING IN EXISTING SHUTDOWN MODE</u>
HC-5P	NON-ESS	A	CIRC. WATER FANS (II)	N	HIGH VIBRATION O/L TRIP ANN.	FAILS AS IS. NO TRANSFER REQUIRED. OTHER BUS DIVISION IS SUFFICIENT TO CONTROL CIRC. WATER.
SL-52	NON-ESS	A	FEED TO HC-5Q/R & P	-	BKR TRIP ANN.	FAILS AS IS. NO TRANSFER REQUIRED. OTHER BUS DIVISION IS SUFFICIENT TO CONTROL CIRC. WATER.
SH-5	NON-ESS	A	FEED TO SL-51, SL-52	-	TWO BKR TRIP	FAILS AS IS. NO TRANSFER REQUIRED. OTHER BUS DIVISION IS SUFFICIENT TO CONTROL CIRC. WATER.



ATTACHEMENT 2



APPENDIX B

WPPSS NUCLEAR PLANT NUMBER 2 (WNPP-2)

COLD SHUTDOWN SYSTEM DEVICE TABLE

NOTES:

- *1) NOTES, AS DESCRIBED UNDER THE HEADING "ALARM POINT", COULD CONSIST OF ANNUNCIATOR ALARMS OR ANY OTHER INDICATIONS OF POWER FAILURE SUCH AS LOSS OF MULTIPLE POSITION INDICATOR LAMPS, ETC.
- 2) THE LOSS OF POSITION INDICATION LAMPS FOR SEVERAL MOV'S OR DEVICES IS INDICATIVE OF A POWER BUS FAILURE. UPON FAILURE OF ONE SET OF INDICATION LAMPS, A REVIEW OF ADJACENT (IDENTIFIED) LAMPS WILL INDICATE POWER FAILURE OF THE RESPECTIVE BUS.
- 3) OTHER DEVICES WITH INDICATION LAMPS ARE POWERED FROM THE SAME BUS AS THIS ONE. VERIFY THE MATCHING GROUP OF DEVICES FROM THIS POWER BUS TO DETERMINE THE POWER LOSS.

(NOTE 3 WILL ALWAYS HAVE A MATCHING GROUP REFERENCE, E.G. GROUP M, P, A, ETC.)



<u>BUS NUMBER</u>	<u>BUS DIV</u>	<u>DEVICE NUMBER</u>	<u>DEVICE DESCRIPTION</u>	<u>PRIMARY EFFECT ON DEVICE</u>	<u>PRIMARY EFFECT ON SYSTEM</u>	<u>ALARM POINT</u>
DP-S1-1C	A	LFMG "A" MOTOR BKR CONTROL 125 VDC	CONTROL VOLTAGE TO MOTOR BKR & RELAY	INABILITY TO OPERATE LFMG	TOTAL LOSS OF "A" OR "B" RECIRC CONTROL	1) RECIRC PUMP A LOW SPEED AUTO TRANSFER CIRCUIT NOT AVAIL- ABLE
DP-S1-2C	B	LFMG "B"	CONTROL VOLTAGE TO MOTOR BKR & RELAY	INABILITY TO OPERATE LFMG	TOTAL LOSS OF "A" OR "B" RECIRC CONTROL	1) RECIRC PUMP B LOW SPEED AUTO TRANSFER CIRCUIT NOT AVAIL- ABLE
SM-1	A	B35-S001A	LFMG SET MOTOR DRIVE	INABILITY TO OPERATE LFMG	TOTAL LOSS OF "A" OR "B" RECIRC CONTROL	UNDER VOLTAGE ANNUNCI- ATION
SM-3	A	B35-S001B	LFMG SET MOTOR DRIVE	INABILITY TO OPERATE LFMG	TOTAL LOSS OF "A" OR "B" RECIRC CONTROL	UNDER VOLTAGE ANNUNCI- ATION
PP-7A-2	A	H13-P634 H13-P612	LOOP A AND B FLOW CNTL & HYDRAULIC POWER UNIT. MASTER FLUX CNTL	INABILITY TO CONTROL RECIRC FLOW	LOSS OF RECIRCULATION FLOW CONTROL	1) "MASTER CONTROLLER OUTPUT SIGNAL ABNORMAL" 2) FLUX CONTROLLER OUTPUT SIGNAL ABNORMAL
US-PP-A	A	H13-P602	FLUX ESTIMATOR INDI- CATORS	LOSS OF INDICATION	LOSS OF RECIRCULATION FLOW CONTROL	LOSS OF SEVERAL NSSS SYSTEMS INCLUDING POWER RANGE FLUX MONITORING
PP-3B-B	A	LFMG "A" VOLT. REG.	LOSS OF VOLTAGE REGULATOR	LOSS OF VOLTAGE CONTROL	CANNOT OPERATE LFMG "A"	SAME 3 POINTS AS PP-2R-B ONLY FOR VALVE A

<u>BUS NUMBER</u>	<u>BUS DIV</u>	<u>DEVICE NUMBER</u>	<u>DEVICE DESCRIPTION</u>	<u>PRIMARY EFFECT ON DEVICE</u>	<u>PRIMARY EFFECT ON SYSTEM</u>	<u>ALARM POINT</u>
PP-2R-B	B	LFMG "B" VOLT. REG.	LOSS OF VOLTAGE REGULATOR	LOSS OF VOLTAGE	CANNOT OPERATE LFMG "B"	1) "SYST B DRYWELL HIGH PRESS INTLK" 2) "FLOW CONTROL VALVE B HYD PWR UNIT START-UP INHIBITED" 3) "VALVE B SERVO AMP INPUT CONTROL SIGNAL ABNORMAL"
PP-2R-B	B		HYDRAULIC POWER UNIT FOR RECIRC FLOW	LOSS OF CONTROL PWR		1) "SYS B DRYWELL HIGH PRESS. INTLK" 2) "FLOW CONTROL VALVE FB HYD PWR UNIT STARTUP INHIBITED" 3) "VALVE B SEKVO AMP INPUT CONTROL SIGNAL ABNORMAL"
SH-13 (SH-1)	A	LF2A	LFMG "A" OUTPUT BREAKER	LOSS OF LFMG SET "A"	LOSS OF 15 HZ RECIRC PUMP "A" OPERATION	UNDER VOLTAGE AND BREAKER TRIP ANNUNCI- ATION
SH-14 (SH-3)	B	LF2B	LFMG "B" OUTPUT BREAKER	LOSS OF LFMG SET "B"	LOSS OF 15 HZ RECIRC PUMP "B" OPERATION	UNDER VOLTAGE AND BREAKER TRIP ANNUNCI- ATION
MC-7C	A	FLOW CONT. HYD PWR UNIT	HYDRAULIC POWER UNIT FOR RECIRC FLOW CONTROL VALVE	MUST LOSE BOTH MC-7C AND MC-8C TO LOSE HYD POWER UNITS	NONE, UNLESS ONE LOOP ALREADY DOWN (SEE MC-8C BELOW)	FLOW CONTROL VALVE A HYD POWER UNIT START-UP INHIBIT
		RRC-V-67A	RECIRC PUMP P DISH VALVE	MOV VALVE FAILS AS IS	REQUIRED TO BE SHUT FOR RHR/SD COOLING	LOSS OF VALVE POSITION IND. ON P602
MC-8C	B	FLOW CONT. HYD POWER UNIT	HYDRAULIC POWER UNIT FOR RECIRC FLOW CONTROL VALVE	MUST LOSE BOTH MC-7C AND MC-8C TO LOSE HYD POWER UNITS	NONE, UNLESS ONE LOOP ALREADY DOWN	FLOW CONTROL VALVE B HYD POWER START-UP INHIBIT

<u>BUS NUMBER</u>	<u>BUS DIV</u>	<u>DEVICE NUMBER</u>	<u>DEVICE DESCRIPTION</u>	<u>PRIMARY EFFECT ON DEVICE</u>	<u>PRIMARY EFFECT ON SYSTEM</u>	<u>ALARM POINT</u>
SM-7	1	CRD-P-1A	CRD PUMP "A"	STOPS PUMPING	LOSS OF RMCRD CONTROL IF OTHER PUMP IS INOPERABLE	1) BUS SM-7 UV ANNUN. 2) CB CRD-1A TRIP ANNUNC.
SM-8	2	CRD-P-1B	CRD PUMP "B"	STOPS PUMPING	LOSS OF RMCRD CONTROL IF OTHER PUMP IS INOPERABLE	1) BUS SM-8 UV ANNUN. 2) CB CRD-1B TRIP ANNUNC.
US-PP-A	A	120 VAC	ROD SELECT LOGIC DISPLAY LOGIC	LOSS OF INDIVIDUAL ROD CONTROL	ROD BLOCK	SEE US-PP-A UNDER GROUP A
PP-7A-A	1	120 VAC	ROD POSITION INDICATION CONTROL	LOSS OF INDIVIDUAL ROD CONTROL	ROD BLOCK	LOSS OF VOLTAGE IND. FOR PP-7A-A ON BD-C

<u>BUS NUMBER</u>	<u>BUS DIV</u>	<u>DEVICE NUMBER</u>	<u>DEVICE DESCRIPTION</u>	<u>PRIMARY EFFECT ON DEVICE</u>	<u>PRIMARY EFFECT ON SYSTEM</u>	<u>ALARM POINT</u>
C72-P001 BACKUP TO TO HG SETS		C72-1070	SAFETY SYSTEMS SCRAM CHANNELS & SCRAM SOLENOIDS	SCRAM SOLENOIDS FAIL OPEN (N.C.)	CONTROL RODS FULL INSERT (SCRAM)	ALL SCRAM ANNUNCIATION
PP-8A-A	2	C72-1070	FEEDER TO SCRAM DISCHARGE VOLUME POS. INDICATOR LIGHTS	NO VALVE POSITION INDICATION VALVES C12-F010 & C12-F011	NONE	LOSS OF VALVE POSIT. IND. ON P603 FOR THESE VALVES
DP-S1-1A	1	C72-1070	TRIP SYSTEM "A" BACKUP SCRAM VALVE C12-F110A	DISABLES BACKUP SCRAM VALVE, F110A	NO SCRAM BACKUP	NONE
			RECIRC PUMP TRIP "A"	DISABLES RECIRC PUMP TRIP CIRCUIT	NO RPT RECIRC PUMP "A" TRIP	
DP-S1-2A	2	C72-1070	TRIP SYSTEM "B" BACKUP SCRAM VALVE C12-F110B	DISABLES BACKUP SCRAM VALVE F110B	NO SCRAM BACKUP	
			RECIRC PUMP TRIP "B"	DISABLES RECIRC PUMP TRIP CIRCUIT	NO RPT RECIRC PUMP "B" TRIP	
HG SET A		C72-1070	ALL OTHER RPS CIRCUITRY	FAIL SAFE DE-ENERGI- ZATION OF CIRCUITS	REACTOR SCRAM	ALL SCRAM ANNUN.

<u>BUS NUMBER</u>	<u>BUS DIV</u>	<u>DEVICE NUMBER</u>	<u>DEVICE DESCRIPTION</u>	<u>PRIMARY EFFECT ON DEVICE</u>	<u>PRIMARY EFFECT ON SYSTEM</u>	<u>ALARM POINT</u>
MC-7B	1	C41-C001A	SLC PUMP A	SLC PUMP INOPERABLE	NO LOOP A FLOW	1) "SLC-P-1A PWR LOSS" LIGHT 2) "SLC DIV 1 OUT OF SERVICE ANNUN.
		C41-F004A	SLC SQUIB VALVE	SQUIB VALVE DISABLED (NC)	NO LOOP A FLOW	1) "SLC-V-4A PWR LOSS" LIGHT 2) "SLC DIV 1 OUT OF SERVICE" ANNUN 3) LOSS OF STATUS LIGHT ON P603
		C41-F001A	SL MOV STORAGE TANK OUTLET LOOP A	MOV FAILS AS IS (NC)	NO LOOP A FLOW	1) "SLC-V-1A PWR LOSS/OL LIGHT 2) "SLC DIV 1 OUT OF SERVICE" ANNUN. 3) LOSS OF POS. IND. ON P603
MC-8B	2	C41-C001B	SLC PUMP B	SLC PUMP INOPERABLE	NO LOOP B FLOW	1) "SLC-P-1B PWR LOSS" LIGHT 2) "SLC DIV 2 OUT OF SERVICE ANNUN.
		C41-F004B	SLC SQUIB VALVE	SQUIB VALVE DISABLED (NC)		1) "SLC-V-4B PWR LOSS" LIGHT 2) "SLC DIV 2 OUT OF SERVICE 3) LOSS OF STATUS LIGHT ON P603
		C41-F001B	SLC MOV STORAGE TANK OUTLET LOOP B	MOV FAILS AS IS (NC)		1) "SLC-V-1B PWR LOSS/OL" LIGHT 2) "SLC DIV 2 OUT OF SERVICE" ANNUN. 3) LOSS OF POS. IND. ON P603

<u>BUS NUMBER</u>	<u>BUS DIV</u>	<u>DEVICE NUMBER</u>	<u>DEVICE DESCRIPTION</u>	<u>PRIMARY EFFECT ON DEVICE</u>	<u>PRIMARY EFFECT ON SYSTEM</u>	<u>ALARM POINT</u>
PP-8A-A	2	H13-P601	SQUIB VALVE READY LIGHTS POS. SWITCHES FOR SLC-V-8 AND SLC-V-31	LOSS OF SQUIB VALVE READY LIGHT ON P603 LOSS OF POS. IND. FOR SLC-V-8 AND SLC-V-31	NONE.	NOTE 2
PP-8A-Z	B	H13-P613	TANK LVL ALARM, TANK LVL & PUMP PRESSURE INDICATION	LOSS OF INDICATIONS ON P603	NONE.	1) "TANK LEVEL HI/LO" ANNUN. NOTE 2.

<u>BUS NUMBER</u>	<u>BUS DIV</u>	<u>DEVICE NUMBER</u>	<u>DEVICE DESCRIPTION</u>	<u>PRIMARY EFFECT ON DEVICE</u>	<u>PRIMARY EFFECT ON SYSTEM</u>	<u>ALARM POINT</u>
PP-3A-A	A	BS-DV-6A	RFW HTR DUMP VALVE	LOSS OF POWER, VALVE FAILS OPEN	NO EFFECT ON SHUTDOWN MODE. AFFECTS FW TEMPERATURE.	1) SEVERAL HEATER HI LEVEL TRIPS 2) STEAM DUMP VALVES NOT FULLY CLOSED 3) LOSS OF POS. IND.
		BS-DV-3A1	RFW HTR DUMP VALVE	LOSS OF POWER, VALVE FAILS OPEN	NO EFFECT ON SHUTDOWN MODE. AFFECTS FW TEMPERATURE.	1) SEVERAL HEATER HI LEVEL TRIPS 2) STEAM DUMP VALVES NOT FULLY CLOSED 3) LOSS OF POS. IND.
		BS-DV-4A	RFW HTR DUMP VALVE	LOSS OF POWER, VALVE FAILS OPEN	NO EFFECT ON SHUTDOWN MODE. AFFECTS FW TEMPERATURE.	1) SEVERAL HEATER HI LEVEL TRIPS 2) STEAM DUMP VALVES NOT FULLY CLOSED 3) LOSS OF POS. IND.
PP-3A-A	A	BS-V-8B BS-V-10A BS-V-10B BS-V-13A BS-DV-5A BS-DV-2A1 BS-DV-2A2 BS-V-27 BS-V-48 BS-V-52A BS-V-52B	NONE RETURN VALVES	LOSS OF POWER, VALVES CLOSE	EFFECT FW TEMP AND CONDENSATE VACUUM	1) SEVERAL HEATER HI LEVEL TRIPS 2) STEAM DUMP VALVES NOT FULLY CLOSED 3) LOSS OF POS. IND. NOTE 2.
PP-2RA-B	B	BS-DV-6B	RFW HTR DUMP VALVE	LOSS OF POWER, VALVES FAILS OPEN	NO EFFECT	1) "STEAM DUMP VALVES NOT FULLY CLOSED" 2) LOSS OF VALVE POSIT. IND. ON BD-T

<u>BUS NUMBER</u>	<u>BUS DIV</u>	<u>DEVICE NUMBER</u>	<u>DEVICE DESCRIPTION</u>	<u>PRIMARY EFFECT ON DEVICE</u>	<u>PRIMARY EFFECT ON SYSTEM</u>	<u>ALARM POINT</u>
PP-2RA-B	B	BS-NRV'S	NON RETURN VALVES	LOSS OF POWER, VALVES CLOSED	NRV SUPPLYING EITHER STEAM OR CONDENSATE	NOTE 2. 1) "STEAM DUMP VALVES NOT FULLY CLOSED" ANN. 2) "LP HEATER-1B HIGH LEVEL TRIP 3) DITTO FOR HTRS 2B, 3B, 4B, 1C, 2C, 3C AND 4C
PP-1B-A		BS-SPVS	SOLENOID PILOT VALVES - TANK LEVEL IND.	BS-V-35A, 39A AND 64 OPEN	NONE.	LOSS OF VALVE POS IND. LIGHTS AND TANK LEVEL ON BD-T
PP-2P-A		BS-SPV'S	SOLENOID PILOT VALVES TANK LEVEL IND.	BS-V-39B AND 68 OPEN	NONE.	LOSS OF POSITION IND. LIGHTS AND TANK LEVEL ON BD-T
PP-8A-A	2	ES-PI-1B	STEAM EXHAUST PRESS. IND. FOR RFT-1B	LOSS OF INDICATION	NONE	LOSS OF VOLTAGE INDICATION ON 80-C FOR PP-8A-A
PP-7A-A	1	ES-PI-1A	STEAM EXHAUST PRESS. IND. FOR RFT-1A	LOSS OF INDICATION	NONE	LOSS OF VOLTAGE INDICATION ON 80-C FOR PP-7A-A

<u>BUS NUMBER</u>	<u>BUS DIV</u>	<u>DEVICE NUMBER</u>	<u>DEVICE DESCRIPTION</u>	<u>PRIMARY EFFECT ON DEVICE</u>	<u>PRIMARY EFFECT ON SYSTEM</u>	<u>ALARM POINT</u>
SM-1	A	P-1A	CONDENSATE PUMP 1A	LOSS OF PUMP	AT 40% RX POWER ONE (1) CONDENSATE PUMP AND ONE (1) BOOSTER PUMP ARE SHUTDOWN. IF THE POWER FAILURE ON ONE BUS IS PRIOR TO 40% RX POWER THEN COND SYSTEM IS LOST. IF A SECOND BUS POWER LOSS IS EXPERIENCED PRIOR TO RX PRESSURE AT 300 PSIG THEN COND SYSTEM IS LOST. NO CONDENSATE PUMPS ARE REQUIRED WHEN RX PRESSURE IS AT 100 PSIG.	1) BUS SM1 UV ANNUNC. 2) CB CIA TRIP ANNUNC.
		P-2A	CONDENSATE BOOSTER PUMP 2A	LOSS OF PUMP		1) ABOVE 2) CB C2A TRIP ANNUNC.
SM-2	B	P-1B	CONDENSATE PUMP 1B	LOSS OF PUMP	AT 40% RX POWER ONE (1) CONDENSATE PUMP AND ONE (1) BOOSTER PUMP ARE SHUTDOWN. IF THE POWER FAILURE ON ONE BUS IS PRIOR TO 40% RX POWER THEN COND SYSTEM IS LOST. IF A SECOND BUS POWER LOSS IS EXPERIENCED PRIOR TO RX PRESSURE AT 300 PSIG THEN COND SYSTEM IS LOST. NO CONDENSATE PUMPS ARE REQUIRED WHEN RX PRESSURE IS AT 100 PSIG.	1) BUS SM2 UV ANNUNC. 2) CB C1B TRIP ANNUNC. 3) CB C2B TRIP ANNUNC.
		P-2B	CONDENSATE BOOSTER PUMP 2B	LOSS OF PUMP		
SM-3	A	P-1C	CONDENSATE PUMP 1C	LOSS OF PUMP	AT 40% RX POWER ONE (1) CONDENSATE PUMP AND ONE (1) BOOSTER PUMP ARE SHUTDOWN. IF THE POWER FAILURE ON ONE BUS IS PRIOR TO 40% RX POWER THEN COND SYSTEM IS LOST. IF A SECOND BUS POWER LOSS IS EXPERIENCED PRIOR TO RX PRESSURE AT 300 PSIG THEN COND SYSTEM IS LOST. NO CONDENSATE PUMPS ARE REQUIRED WHEN RX PRESSURE IS AT 100 PSIG.	1) BUS SM3 UV ANNUNC. 2) CB C1C TRIP ANN. 3) CB C2C TRIP ANN.
		P-2C	CONDENSATE BOOSTER PUMP 2C	LOSS OF PUMP		
MC-1A	A	COND-V-146A	COND OUTLET FROM LP HTR 5A	MOV FAILS AS IS N.O. LOSS OF VALVE POSITION INDICATION	NONE.	LOSS OF POSITION IND. ON BD-T
		COND-V-142A	COND INLET TO LP HTR 5A	MOV FAILS AS IS N.O. LOSS OF VALVE POSITION INDICATION	NONE.	LOSS OF POSITION IND. ON BD-T
		COND-V-134A	COND OUTLET FROM LP HTR 2A	MOV FAILS AS IS N.O. LOSS OF VALVE POSITION INDICATION	NONE.	LOSS OF POSITION IND. ON BD-T
		COND-V-615A	SEALING STEAM EVAP BLOWDOWN TO CONDENSER	MOV FAILS AS IS N.O. LOSS VALVE POSITION INDICATION	NONE.	NONE - NO POSITION INDICATION IN THE CONTROL ROOM
MC-1B	A	COND-V-123A	COND INLET TO LP HTR 1A	MOV FAILS AS IS N.O. LOSS OF VALVE POSITION INDICATION	NONE.	LOSS OF VALVE POSITION ON BD-T

<u>BUS NUMBER</u>	<u>BUS DIV</u>	<u>DEVICE NUMBER</u>	<u>DEVICE DESCRIPTION</u>	<u>PRIMARY EFFECT ON DEVICE</u>	<u>PRIMARY EFFECT ON SYSTEM</u>	<u>ALARM POINT</u>
MC-1B	A	COND-V-149	RFP BYPASS VALVE	MOV FAILS AS IS VALVE COULD BE OPEN OR CLOSED DEPENDENT ON OPERATIONS	REQUIRED TO BE OPEN FOR SYSTEM S/D	LOSS OF POSITION INDICA- TION ON BD-A
MC-2B	B	COND-V-140C	COND OUTLET FROM LP HTR 4C	MOV FAILS AS IS (N.O.) LOSS OF VALVE POSITION INDICATION ON BD-T	NONE.	O/L TRIP ANNUNCIATION OF FEED TO MCC'S AND NOTE 2
		COND-V-135C	COND INLET TO LP HTR 3C	MOV FAILS AS IS (N.O.) LOSS OF VALVE POSITION INDICATION ON BD-T	NONE.	O/L TRIP ANNUNCIATION OF FEED TO MCC'S AND NOTE 2
MC-2C	B	COND-V-146B	COND OUTLET FROM LP HTR 5B	MOV FAILS AS IS (N.O.) LOSS OF VALVE POSITION INDICATION	NONE.	LOSS OF VALVE POSIT. IND. ON BD-T
		COND-V-157	COND PRESSURE CON- TROL VALVE INLET	VALVE FAILS AS IS (N.O.) POSITION INDI- CATION LOST	NONE.	LOSS OF VALVE POSIT. IND. ON BD-A
		COND-V-158	COND PRESS. CONTROL VALVE INLET	VALVE FAILS AS IS (N.O.) POSITION INDI- CATION LOST	NONE.	LOSS OF VALVE POSIT. IND. ON BD-A
		COND-V-159	COND PRESS. CONTROL VALVE INLET	VALVE FAILS AS IS (N.O.) POSITION INDI- CATION LOST	NONE.	LOSS OF VALVE POSIT. IND. ON BD-A
MC-2D	B	MS-V-110A	STEAM JET AIR EJECTOR STEAM	MOV FAILS AS IS (N.O.) POSITION INDICATION LOST	NONE.	
		AR-EX-1B	GLAND CONDENSER EXHAUSTER	LOSS OF EXHAUSTER	NONE.	
		COND-V-114B COND-V-111B	COND-HX-8B COOLING WATER SUPPLY	MOV FAILS AS IS (N.O.) LOSS OF VALVE POSI- TION INDICATION	NONE.	LOSS OF VALVE POSIT. IND. ON BD-A

<u>BUS NUMBER</u>	<u>BUS DIV</u>	<u>DEVICE NUMBER</u>	<u>DEVICE DESCRIPTION</u>	<u>PRIMARY EFFECT ON DEVICE</u>	<u>PRIMARY EFFECT ON SYSTEM</u>	<u>ALARM POINT</u>
		COND-V-123B	COND INLET TO LP HTR 1B	MOV FAILS AS IS (N.O.) LOSS OF VALVE POSITION INDICATION	NONE.	LOSS OF VALVE POSIT. IND. ON BD-T
MC-2D	B	COND-V-123C	COND INLET TO LP HTR 1C	MOV FAILS AS IS (N.O.) LOSS OF VALVE POSITION INDICATION	NONE.	LOSS OF VALVE POSIT. IND. ON BD-T
		CBP-AOP-1B	BOOSTER PUMP 1B AUX LUBE OIL PUMP	PUMP DISABLED. REQUIRED ONLY WHEN THE MAIN OIL PUMP IS DISABLED.	NONE.	
	B	OG-V-125B OG-V-149B	OG DISCHARGE FROM EJECTOR CONDENSER 8B	VALVES FAIL AS IS, LOSS OF POSITION INDICATION	NONE.	SEE PAGE 2 - MC-2D
MC-2R	B	COND-V-142B	COND INLET TO LP HTR 5B	MOV FAILS AS IS (N.O.) LOSS OF VALVE POSITION INDICATION	NONE.	LOSS OF POSIT. IND. ON BD-T
		COND-V-134B	COND OUTLET FROM HTR 2B	MOV FAILS AS IS (N.O.) LOSS OF VALVE POSITION INDICATION	NONE.	LOSS OF POSIT. IND. ON BD-T
		COND-V-134C	COND OUTLET FROM HTR 2C	MOV FAILS AS IS (N.O.) LOSS OF VALVE POSITION INDICATION	NONE.	LOSS OF POSIT. IND. ON BD-T
		AR-V-3B	MAIN CONDENSER VACUUM BKR VALVE	MOV FAILS AS IS (N.O.) LOSS OF VALVE POSITION INDICATION	NONE.	
MC-2R-A	B	COND-V-140B	COND OUTLET FROM LP HTR 4B	MOVS FAIL AS IS LOSS OF POSITION INDICATION	NONE.	LOSS OF VALVE POSIT. IND. LIGHTS ON BD-T
		COND-V-135B	COND INLET TO LP HTR 3B	MOVS FAIL AS IS LOSS OF POSITION INDICATION	NONE.	LOSS OF VALVE POSIT. IND. LIGHTS ON BD-T

<u>BUS NUMBER</u>	<u>BUS DIV</u>	<u>DEVICE NUMBER</u>	<u>DEVICE DESCRIPTION</u>	<u>PRIMARY EFFECT ON DEVICE</u>	<u>PRIMARY EFFECT ON SYSTEM</u>	<u>ALARM POINT</u>
MC-3A	A	COND-V-140A	COND OUTLET FROM LP HTR 4A	MOV FAIL AS IS LOSS OF POSITION INDICATION	NONE	LOSS OF VALVE POSIT. IND. ON BD-T
MC-3A	A	COND-V-135A	COND INLET TO LP HTR 3A	MOV FAIL AS IS LOSS OF POSITION INDICATION	NONE	LOSS OF VALVE POSIT. IND. ON BD-T
MC-3B	A	AR-V-3A	MAIN CONDENSER VACUUM BKR VALVE	MOV FAILS AS IS (N.C.) POSITION INDICATION LOST	NONE.	LOSS OF VALVE POSIT. IND.
		AR-V-3C	MAIN CONDENSER VACUUM BKR VALVE	MOV FAILS AS IS (N.C) POSITION INDICATION LOST	NONE.	LOSS OF VALVE POSIT. IND.
		COND-V-141A	COND HTR 3A,B,C 4A,B,C BYPASS	MOV FAIL AS IS (N.C.) POSITION IND. LOST ON BD-T		LOSS OF VALVE POSIT. ON BD-T
		COND-V-141B COND-V-144	COND HTR 2A,B,C 5A,B BYPASS	MOV FAIL AS IS (N.C.) POSITION IND. LOST ON BD-T		LOSS OF VALVE POSIT. ON BD-T
		COND-V-609A COND-V-609C	COND HTR 1A, 1B BYPASS	MOV FAIL AS IS (N.C.) POSITION IND. LOST ON BD-T		LOSS OF VALVE POSIT. ON BD-T
		COND-V-184 COND-V-187	STEAM EXAPORATOR ISO VALVES	NO EFFECT.	NONE.	LOSS OF VALVE POSIT. ON BD-A
MC-3C	A	OG-V-125A OG-V-149A	OG DISCHARGE FROM EJECTOR CONDENSER 8A	VALVES FAIL AS IS, LOSS OF POSITION INDICATION	NONE.	NOTE 2 AND O/L TRIP ANNUNCIATION
		CBP-AOP-1A	BOOSTER PUMP 1A AUX LUBE OIL PUMP	PUMP DISABLED.	REQUIRED ONLY WHEN THE MAIN OIL PUMP IS DISABLED, OR WHEN STARTING, STOPPING THE BOOSTER PUMPS	NOTE 2 AND O/L TRIP ANNUNCIATION

<u>BUS NUMBER</u>	<u>BUS DIV</u>	<u>DEVICE NUMBER</u>	<u>DEVICE DESCRIPTION</u>	<u>PRIMARY EFFECT ON DEVICE</u>	<u>PRIMARY EFFECT ON SYSTEM</u>	<u>ALARM POINT</u>
		AR-EX-1A	GLAND CONDENSER EXHAUSTER	LOSS OF EXHAUSTER	NONE.	NOTE 2 AND O/L TRIP ANNUNCIATION
MC-3C	A	COND-V-114A COND-V-111A	COND-HX-8A COOLING WATER SUPPLY	MOV5 FAILS AS IS (N.O.) LOSS OF VALVE POSITION INDICATION	NONE.	NOTE 2 AND O/L TRIP ANNUNCIATION
DP-S1-1C	A	125 VDC BUS BKR NO. 4	4160 CONTROL VOLTAGE	LOSS OF CLOSURE AND TRIP VOLTAGE AT THE SWITCHGEAR FOR COND-P-1A AND 1C COND-P-2A AND 2C	UNABLE TO TRIP AND CLOSE PUMP BREAKERS	LOSS OF BREAKER STATUS LIGHTS ON BD-A.
		125 VDC BUS BKR NO. 5	4160 CONTROL VOLTAGE	LOSS OF CLOSURE AND TRIP VOLTAGE AT THE SWITCHGEAR FOR COND-P-1A AND 1C COND-P-2A AND 2C	UNABLE TO TRIP AND CLOSE PUMP BREAKERS	LOSS OF BREAKER STATUS LIGHTS ON BD-A.
DP-S1-2C	B	125 VDC BUS BKR NO. 3	4160 CONTROL VOLTAGE	LOSS OF CLOSURE AND TRIP VOLTAGE FOR COND-P-1B AND COND-P-2B	UNABLE TO TRIP AND CLOSE PUMP BREAKERS	LOSS OF BREAKER STATUS LIGHTS ON BD-A.
PP-7A-A	1	COND-DPT-5 SRV-21	COND PCV-5 CONTROL LOOP GLAND SEAL STM COND BYPASS VALVE	COND-PCV-5 CLOSES LOSS OF DP INDICATION	100% FLOW THROUGH THE GLAND SEAL STEAM CONDENSER LOSS COND BOOSTER PUMPS/RFW	LOSS OF MOST BOP ANALOG LOOPS. IN DIV 1 AND DIV A. WITH ASSOCIATED ALARMS AND LOSS OF CONTROL AND INDICAT. LOSS OF VOLTAGE IND. FOR PP-7A-A ON BD-C.
PP-7A-A	1	COND-FT-11 SRV 17	FILTER DEMIN BYPASS VALVE COND-LCV-11 CONTROL LOOP	COND-LCV-11 CLOSES LOSS OF FLOW INDICATION	NONE.	LOSS OF MOST BOP ANALOG LOOPS. IN DIV 1 AND DIV A. WITH ASSOCIATED ALARMS AND LOSS OF CONTROL AND INDICAT. LOSS OF VOLTAGE IND. FOR PP-7A-A ON BD-C.

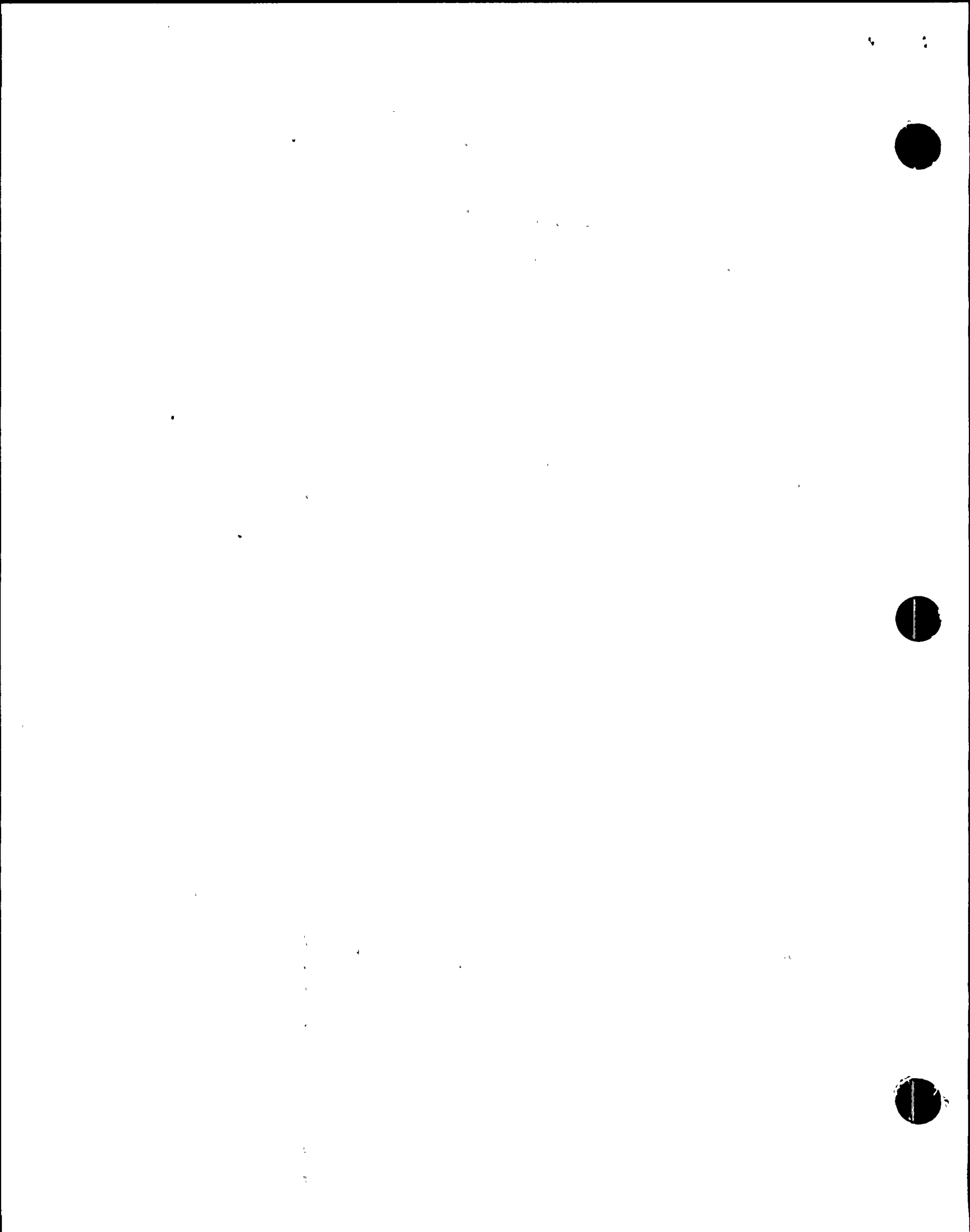

<u>BUS NUMBER</u>	<u>BUS DIV</u>	<u>DEVICE NUMBER</u>	<u>DEVICE DESCRIPTION</u>	<u>PRIMARY EFFECT ON DEVICE</u>	<u>PRIMARY EFFECT ON SYSTEM</u>	<u>ALARM POINT</u>
DP-S1-1B	A	RELAYS PRM-1 PRM-3	INTERLOCKS TO AR-SPV-1-1 AR-SPV-1-2	SPVS DEENERGIZE AR-V-1 CLOSE	AIR REMOVAL SYSTEM IS ISOLATED. CONDENSER LOSES VACUUM SLOWLY.	
PP-1B-A	A	OG-V-129A	DRAIN DISCHARGE VALVE FOR EJECTOR CONDENSER 8A DRIP POT	OG-V-129A OPENS. LOSS LOSS OF POSITION INDICATION	NONE.	NOTE 2, LOSS OF POSITION INDICATION FOR ALL LISTED DEVICES
		AR-SPV-2A AR-SPV-2B	SPVS FOR AR-V-2A, 2B FOR AIR EJECTOR A	SPVS DEENERGIZE AR-V-2A AND 2B CLOSE. LOSS OF POSITION INDICATION	AIR EJECTOR A LOST. IF IN USE, CONDENSER VACUUM LOST	NOTE 2, LOSS OF POSITION INDICATION FOR ALL LISTED DEVICES
		AR-SPV-1-1 AR-SPV-1-2	SPVS FOR AR-V-1, VACUUM LINE FROM CONDENSER	SPVS DEENERGIZE AR-V-1 CLOSES. LOSS OF POSITION INDICATION	ENTIRE AIR REMOVAL SYSTEM IS ISOLATED. CONDENSER SLOWLY LOSES VACUUM.	NOTE 2, LOSS OF POSITION INDICATION FOR ALL LISTED DEVICES
		COND-FSVP 15A COND-FSVP 15C	COND. BOOSTER MINIMUM FLOW VALVES	COND-PCV-15A AND C THROTTLES. LOSS OF POSITION INDICATION	NONE.	LOSS OF POSITION IND. ON BD-A.
		COND-SPV-40	CONTROL AIR TO COND-PCV-40 CONDENSE HOOD SPRAY VALVE	LOSS OF ABILITY TO OPEN COND-PCV-40 WHICH IS NORMALLY CLOSED	NONE.	NOTE 2, LOSS OF POSI- TION INDICATION FOR ALL LISTED DEVICES
		COND-SPV-17	CONTROL AIR TO COND-V-17 CONDENSER/ CST CROSS TIE VALVE	COND-V-17 CLOSES WHEN COND-SPV-17 DEENER- GIZES	LOSS OF INDICATION COND-V-17	NOTE 2, LOSS OF POSI- TION INDICATION FOR ALL LISTED DEVICES



<u>BUS NUMBER</u>	<u>BUS DIV</u>	<u>DEVICE NUMBER</u>	<u>DEVICE DESCRIPTION</u>	<u>PRIMARY EFFECT ON DEVICE</u>	<u>PRIMARY EFFECT ON SYSTEM</u>	<u>ALARM POINT</u>
PP-2P-A	B	COND-FSPV 15B	COND. BOOSTER PUMP MINIMUM FLOW VALVE	COND-FCV-15B THROTTLES LOSS OF POSITION INDICATION	NONE	LOSS OF POSITION IND. ON BD-A.
		AR-SPV-2C AR-SPV-2D	SPVS FOR AR-V-2C AND 2D FOR AIR EJECTOR B	SPVS DEENERGIZE AR-V-2C AND 2D CLOSE. LOSS OF POSITION INDICATION.	AIR EJECTOR B LOST. IF IN USE. CONDENSER VACUUM LOST.	
PP-8A-2C-A	B	COND-SPV-76	CONTROL AIR FOR COND-V-76, FILTER DEMIN. BYPASS VALVE	COND-V-76 OPENS WHEN COND-SPV-76 DEENER- GIZES	PARTIAL BYPASS OF FILTER DEMINERALIZERS, REDUCES SYSTEM FRIC- TION DROP - SOME INCREASED FLOW IN SYSTEM.	
PP-2P-A	B	OG-V-129B	DRAIN DISCHARGE VALVE FOR EJECTOR COND. 8B DRIP POT.	OG-V-129B OPENS. LOSS OF POS. IND.	NONE.	NOTE 2.

<u>BUS NUMBER</u>	<u>BUS DIV</u>	<u>DEVICE NUMBER</u>	<u>DEVICE DESCRIPTION</u>	<u>PRIMARY EFFECT ON DEVICE</u>	<u>PRIMARY EFFECT ON SYSTEM</u>	<u>ALARM POINT</u>
MC-1A	A	TG-BLP-1	BEARING LIFT PUMP	LOSS OF INDICATION LOSS OF BEARING LIFT PUMP	REQUIRED FOR MAIN TURBINE S/D	O/L TRIP ANNUNCIATION AND NOTE 2.
		TG-BOP-1	BEARING OIL PUMP	LOSS OF INDICATION LOSS OF BEARING OIL PUMP	REQUIRED FOR MAIN TURBINE S/D	O/L TRIP ANNUNCIATION AND NOTE 2.
		TG-SOBP	SEAL OIL BACKUP PUMP	LOSS OF INDICATION LOSS OF SEAL OIL BACKUP PUMP	REQUIRED FOR MAIN TURBINE S/D	O/L TRIP ANNUNCIATION AND NOTE 2.
		TO-EX-1	TURBINE OIL VAPOR EXTRACTOR	LOSS OF POWER AND INDICATION	OPERATOR WILL TRIP TURBINE PER PPM 2.5.7	O/L TRIP ANNUNCIATION AND NOTE 2.
		TG-EHP-1A	ELECTRO-HYDRAULIC PUMP 1A	LOSS OF POWER, CONTROL AND IND. LOSE PUMP 1A	AUTO START OF EHP-1B	O/L TRIP ANNUNCIATION AND NOTE 2.
MC-2C	B	TG-EHP-1B	ELECTRO-HYDRAULIC PUMP 1B	LOSS OF POWER, CONTROL AND INDICATION	AUTO START OF EHP-1A	EH FLUID LOW PRESS ANN. (IF THIS IS THE RUNNING PUMP)
MC-3B	A	TG-TNG-1	LOSS OF INDICATION LOSS OF MAIN TURBINE TURNING GEAR	DAMAGE TO TURBINE IF SECURED	REQUIRED FOR MAIN TURBINE S/D	1) T.G. FAILURE ANNUNC. 2) ZERO TURBINE SPEED ANNUNC.
SM-75	A	TSW-P-1A	PLANT SERVICE WATER PUMP	LOSS OF POWER TO TSW-P-1A	TSW-P-1B WILL AUTO START	1) BREAKER TRIPPED ANNUNC. 2) BUS UV ANNUNC.
SM-85	B	TSW-P-1B	PLANT SERVICE WATER PUMP	LOSS OF POWER TO TSW-P-1B	TSW-P-1B WILL AUTO START	1) BREAKER TRIPPED ANNUNC. 2) BUS UV ANNUNC.
MC-S2-1B	A	TG-EOP-1	EMERG. OIL PUMP	LOSE AUTO START ON LOSS OF TG-BOP-1	NONE, AS LONG AS MAIN OIL PUMP AVAILABLE (TG-BOP-1)	LOSS OF PUMP STATUS LIGHTS ON BD-A

<u>BUS NUMBER</u>	<u>BUS DIV</u>	<u>DEVICE NUMBER</u>	<u>DEVICE DESCRIPTION</u>	<u>PRIMARY EFFECT ON DEVICE</u>	<u>PRIMARY EFFECT ON SYSTEM</u>	<u>ALARM POINT</u>
MC-S2-1B	A	TG-ASOBP-1B	AIR SIDE BACKUP SEAL OIL PUMP	LOSE AUTO START (OF TG-ASOBP-1B) ON LOSS OF MAIN SEAL OIL PUMP	NONE, AS LONG AS MAIN OIL PUMP (TG-ASOP-1) IS AVAILABLE	LOSS OF PUMP STATUS LIGHTS ON BD-A
US-PP	A	AC PANEL AC-2 IN DEH CAB.00	VITAL AC POWER TO DEH CONTROLLER	LOSS OF DEH CONTROLLER AFTER TURBINE TRIP	UNABLE TO CONTROL PRESSURE DURING SHUTDOWN	LOSS OF VOLTAGE INDICATION ON BD-C FOR US-PP
PP-1B-A	A	TURNING GEAR SOLENOID VALVES	TURNING GEAR ENGAGE/DISENGAGE SOLENOID VALVES	LOSS OF MAIN TURBINE TURNING GEAR	REQUIRED FOR MAIN TURBINE S/D	LOSS OF INDICATION ON BD-B
PP-3A-A	A	MD-SPV-75 THRU 87	DRAIN VALVES	VALVES FAIL OPEN	REQUIRED TO OPEN ON NORMAL S/D	DRAIN VALVES OPEN TO DEH CONTROLLER ANNUNCIATOR
		TSW-TE-8 TSW-MV/1-8B TSW-1/P-8B TSW-TCV-8	PLANT SERVICE WATER TCV TO MAIN TURBINE OIL COOLERS	TSW-TCV-8 WILL CLOSE	TURBINE TRIP AND LOSS OF MAIN OIL COOLERS	"HIGH BEARING TEMP" ANNUNC.
PP-7A-C	A	TSW-V-53A	TSW-P-1A DISCHARGE VALVE (MOV)	NO VALVE WILL FAIL AS IS	NONE.	
PP-8A-C	B	TSW-V-53B	TSW-P-1B DISCHARGE VALVE (MOV)	NO VALVE WILL FAIL AS	NONE	
PP-8A-Z	B	INTERCEPT AND REHEAT STOP VALVES	CONTROL & INDICATION FOR INTERCEPTOR AND REHEAT STOP VALVES	LOSS OF QUICK ISOLATION AFTER LOAD REJECTION	TURBINE STILL TRIPS ON LOAD REJECTION - NO EFFECT	LOSS OF VALVE POSIT. INDICATION ON BD-B
DP-S1-1C-1	A	TG-EOP-1	CONTROL & INDICATION EMERG. OIL PUMP	STARTS ONLY ON LOSS OF TG-BOP-1	NONE.	1) EMERGENCY OIL PUMP OVERLOAD NOTE 2
DP-S1-1C-1	A	TG-ASOBP-1A	CONTROL & INDICATION SEAL OIL BACKUP PUMP	LOSS OF AIR SIDE BACKUP SEAL OIL PUMP	NONE IF TG-ASOP-1 IS AVAILABLE	1) AIR SIDE SEAL OIL BACKUP PUMP OVERLOAD NOTE 2

<u>BUS NUMBER</u>	<u>BUS DIV</u>	<u>DEVICE NUMBER</u>	<u>DEVICE DESCRIPTION</u>	<u>PRIMARY EFFECT ON DEVICE</u>	<u>PRIMARY EFFECT ON SYSTEM</u>	<u>ALARM POINT</u>
DP-S1-2C	B	CONT. CKT	VOLT REG.	LOSS OF LOAD FOLLOWING CAPABILITY	UNABLE TO PROPERLY UNLOAD TURBINE	1) DEH CONTROL "REGULATOR SUPPLY BKR OPEN" 2) POWER FAILURE ALARM TO DEH
DP-S1-2C-2	B	20/BV1 BV2, BV3 BV4	LOSS OF BYPASS VALVE RESET CAPABILITY	UNABLE TO RESET BYPASS VALVES AFTER TURBINE TRIP	UNABLE TO CONTROL PRESSURE DURING NORMAL SHUTDOWN	
PP-7A-C-A	A	RPWA-010,011 SPWA-010,011 TPWA-035,036, VALVE 037	TSW-V-53A CONTROL TSW-P-1A DISCHARGE	MOV FAILS AS IS OPEN IF ASSOC. PUMP IS RUNNING	NONE.	LOSS OF POSITION IND. FOR TSW-V-53A ON BD-A
PP-8A-C-A	B	RPWA-010,011 SPWA-010,011 TPWA-035,036, VALVE 037	TSW-V-53B CONTROL TSW-P-1B DISCHARGE	MOV FAILS AS IS OPEN IF ASSOC. PUMP IS RUNNING	NONE.	LOSS OF POS. IND. ON BD-A



<u>BUS NUMBER</u>	<u>BUS DIV</u>	<u>DEVICE NUMBER</u>	<u>DEVICE DESCRIPTION</u>	<u>PRIMARY EFFECT ON DEVICE</u>	<u>PRIMARY EFFECT ON SYSTEM</u>	<u>ALARM POINT</u>
SM-1	A	CWP-1A	CIRC WATER PUMP	LOSS OF PUMP	UNTIL RX PRESSURE IS BELOW 100 PSIG WHEN 2 PUMPS CAN BE SHUT-DOWN NEED ONLY 2 PUMPS	SEE SM-1 GROUP F SHEET 1
SM-2	B	CWP-1B	CIRC WATER PUMP	LOSS OF PUMP	UNTIL RX PRESSURE IS BELOW 100 PSIG WHEN 2 PUMPS CAN BE SHUT-DOWN NEED ONLY 2 PUMPS	SEE SM-2 SHEET 1
SM-3	A	CWP-1C	CIRC WATER PUMP	LOSS OF PUMP	UNTIL RX PRESSURE IS BELOW 100 PSIG WHEN 2 PUMPS CAN BE SHUT-DOWN NEED ONLY 2 PUMPS	SEE SM-3 SHEET 1
MC-1B	A	CW-V-2A CW-V-2C	CONDENSER INLET VALVE	MOV FAILS IN POSITION N.O.	NONE.	LOSS OF VALVES POSITION INDICATION ON BD-A
MC-2D	B	CW-V-3B	CONDENSER OUTLET VALVE	MOV FAILS IN POSITION N.O.	NONE.	LOSS OF VALVES POSITION INDICATION ON BD-A
MC-2P	B	CW-V-2B	CONDENSER INLET VALVE	MOV FAILS IN POSITION N.O.	NONE.	LOSS OF VALVES POSITION INDICATION ON BD-A
MC-3C	A	CW-V-3A CW-V-3C	CONDENSER OUTLET VALVE	MOV FAILS IN POSITION N.O.	NONE.	LOSS OF VALVES POSITION INDICATION ON BD-A
MC-5L	A	CW-FN-19 CW-FN-20 CW-FN-21 CW-FN-22	CIRC WATER FANS	FAN MOTORS STOP	NO EFFECT, NEVER LOSE MORE THAN $\frac{1}{2}$ OF 36 TOTAL FANS	1) "HI VIBRATION/OLVD" ANNUNC. ON BD-H 2) INDICATION OF FANS STOPPED

<u>BUS NUMBER</u>	<u>BUS DIV</u>	<u>DEVICE NUMBER</u>	<u>DEVICE DESCRIPTION</u>	<u>PRIMARY EFFECT ON DEVICE</u>	<u>PRIMARY EFFECT ON SYSTEM</u>	<u>ALARM POINT</u>
MC-5M	A	CW-FN-23 CW-FN-24 CW-FN-31 CW-FN-32 CW-FN-33	CIRC WATER FANS	FAN MOTORS STOP	NO EFFECT, NEVER LOSE MORE THAN $\frac{1}{2}$ OF 36 TOTAL FANS	1) "HI VIBRATION/OLVD" ANNUNC. ON BD-M 2) INDICATION OF FANS STOPPED
MC-5N	A	CW-V-1A CW-V-1C CW-V-10	CIRC WATER PUMP DIS-CHARGE MOV COOLING TOWER BYPASS VALVE	MOV FAILS IN POSITION (N.O.) MOV FAILS AS IS (H.C.)	NONE. NONE.	NO ALARM IN CONTROL ROOM NO ALARM IN CONTROL ROOM
MC-5P	A	CW-FN-25 CW-FN-26 CW-FN-27 CW-FN-28	CIRC WATER FANS	FAN MOTORS STOP	NO EFFECT, NEVER LOSE MORE THAN $\frac{1}{2}$ OF 36 TOTAL FANS	1) HI VIBRATION/OLVD" ANNUNC. ON BD-M 2) INDICATION OF FANS STOPPED
MC-5Q	A	CW-FN-29 CW-FN-30 CW-FN-34 CW-FN-35 CW-FN-36	CIRC WATER FANS	FAN MOTORS STOP	NO EFFECT, NEVER LOSE MORE THAN $\frac{1}{2}$ OF 36 TOTAL FANS	1) HI VIBRATION/OLVD" ANNUNC. ON BD-M 2) INDICATION OF FANS STOPPED
MC-5R	A	CW-V-7,8,11	COOLING TOWER 2A, 2B, 2C SUPPLY VALVES	MOV'S FAIL AS IS - MAY BE OPEN OR CLOSED	NONE.	NO ALARM.
MC-6L	B	CW-FN-1 CW-FN-2 CW-FN-3 CW-FN-4	CIRC WATER FANS	FAN MOTORS STOP	NO EFFECT, NEVER LOSE MORE THAN $\frac{1}{2}$ OF 36 TOTAL FANS	1) COOLING TOWER 1A FANS 1-6 HI VIB/OL 2) INDICATION OF FANS STOPPED
MC-6M	B	CW-FN-5 CW-FN-6 CW-FN-13 CW-FN-14 CW-FN-15	CIRC WATER FANS	FAN MOTORS STOP	NO EFFECT, NEVER LOSE MORE THAN $\frac{1}{2}$ OF 36 TOTAL FANS	1) COOLING TOWER 1A FANS 1-6 HI VIB/OL 2) COOLING TOWER 1C FANS 13-18 HI VIB/OL



<u>BUS NUMBER</u>	<u>BUS DIV</u>	<u>DEVICE NUMBER</u>	<u>DEVICE DESCRIPTION</u>	<u>PRIMARY EFFECT ON DEVICE</u>	<u>PRIMARY EFFECT ON SYSTEM</u>	<u>ALARM POINT</u>
MC-6P	B	CW-FN-7 CW-FN-8 CW-FN-9 CW-FN-10	CIRC WATER FANS	FAN MOTORS STOP	NO EFFECT, NEVER LOSE MORE THAN 1/2 OF 36 TOTAL FANS	1) COOLING TOWER 1B FANS 7-12 HI VIB/OL
MC-6Q	B	CW-FN-11 CW-FN-12 CW-FN-16 CW-FN-17 CW-FN-18	CIRC WATER FANS	FAN MOTORS STOP	NO EFFECT, NEVER LOSE MORE THAN 1/2 OF 36 TOTAL FANS	1) COOLING TOWER 1B FANS 7-12 HI VIB/OL 2) COOLING TOWER 1C FANS 13-18 HI VIB/OL
MC-6R	B	CW-V-4,5,6	COOLING TOWER 1A, 1B, 1C SUPPLY	MOV'S FAIL AS IS - MAY BE OPEN OR CLOSED	NONE.	NO ALARM.
MC-6N	B	CW-V-1B	CIRC. WATER PUMP B DISCHARGE MOV	MOV FAILS AS IS (N.O.)	NONE.	NO ALARM.
PP-7A-C-A	A	TPWA 91,92 RPWA 92,92 SPWA 91,92	SUPERVISORY CIRCUIT FOR CW-V-10 COOLING TOWER BYPASS VALVE	MOV FAILS AS IS - (N.C.) LOSS VALVE POSITION INDICATION	NONE.	LOSS OF POSITION IND. FOR CW-V-10 ON BD-M
PP-7A-Z	A	RCWA 91,92 SCWA 91,92 TCWA 91,92	SUPERVISORY CIRCUIT FOR CW-V-10 COOLING TOWER BYPASS VALVE	MOV FAILS AS IS - (N.C.) LOSS VALVE POSITION INDICATION	NONE.	LOSS OF POSITION IND. FOR CW-V-10 ON BD-M
		RCFA 055 TO 060 SCEA 055 TO 060 TCEA 055 TO 060	SUPERVISORY CIRCUIT FOR CW-V-7,8,11 COOLING TOWER SUPPLY VALVES	MOV'S FAILS AS IS - WHICH MAY BE OPEN OR CLOSED. LOSS OF VALVE POSITION INDICATION	NONE.	LOSS OF POSITION IND. FOR THESE VALVES ON BD-M IN THE CONTROL ROOM.
		TCEA 001 TO 019 RCEA 001 TO 019 SCEA 001 TO 019	SUPERVISORY CIRCUIT CW-FN-19 TO 34	LOSS OF FAN CONTROL. FAN MOTORS STOP. LOSS OF FAN OPERATION INDICATION	NO EFFECT, NEVER LOSE MORE THAN 1/2 OF 36 TOTAL FANS	LOSS OF FAN STATUS LIGHTS ON BD-M FOR FANS CW-FN-19 THRU CW-FN-36



<u>BUS NUMBER</u>	<u>BUS DIV</u>	<u>DEVICE NUMBER</u>	<u>DEVICE DESCRIPTION</u>	<u>PRIMARY EFFECT ON DEVICE</u>	<u>PRIMARY EFFECT ON SYSTEM</u>	<u>ALARM POINT</u>
		TCEA 049 TO 054 RCEA 049 TO 054 SCEA 049 TO 054	SUPERVISORY CIRCUIT CW-FN-35 AND 36	LOSS OF FAN CONTROL. FAN MOTORS STOP. LOSS OF FAN OPERATION INDICATION	NO EFFECT, NEVER LOSE MORE THAN 1/2 OF 36 TOTAL FANS	LOSS OF FAN STATUS LIGHTS ON BD-M FOR FANS CW-FN-19 THRU CW-FN-36
PP-8A-Z	B	TCEB 001 TO 048 RCEB 001 TO 048 SCEB 001 TO 048	SUPERVISORY CIRCUIT CW-FN-1 TO 16	LOSS OF FAN CONTROL. FAN MOTORS STOP. LOSS OF FAN OPERATION INDICATION	NO EFFECT, NEVER LOSE MORE THAN 1/2 OF 36 TOTAL FANS	LOSS OF FAN STATUS LIGHTS ON BD-M FOR FANS CW-FN-1 THRU CW-FN-18
PP-8A-Z	B	TCEB 049 TO 054 RCEB 049 TO 054 SCEB 049 TO 054	SUPERVISORY CIRCUIT CW-FN-17 AND 18	LOSS OF FAN CONTROL. FAN MOTORS STOP. LOSS OF FAN OPERATION INDICATION	NO EFFECT, NEVER LOSE MORE THAN 1/2 OF 36 TOTAL FANS	LOSS OF FAN STATUS LIGHTS ON BD-M FOR FANS CW-FN-1 THRU CW-FN-18
PP-8A-Z	B	RCEB 055 TO 060 SCEB 055 TO 060 TCEB 055 TO 060	SUPERVISORY CIRCUIT FOR CW-V-4,5,6 COOLING TOWER SUPPLY VALVES	MOV'S FAIL AS IS - WHICH MAY BE OPEN OR CLOSED. LOSS OF VALVE POSITION INDICATION	NONE.	LOSS OF FAN STATUS LIGHTS ON BD-M FOR FANS CW-FN-1 THRU CW-FN-18

<u>BUS NUMBER</u>	<u>BUS DIV</u>	<u>DEVICE NUMBER</u>	<u>DEVICE DESCRIPTION</u>	<u>PRIMARY EFFECT ON DEVICE</u>	<u>PRIMARY EFFECT ON SYSTEM</u>	<u>ALARM POINT</u>
LP-5R-A	A	TEA 001 TO 054 REA 001 TO 054 SEA 001 TO 054	SUPERVISORY CIRCUIT CW-FN-19 TO 36	LOSS OF FAN CONTROL. FANS CONTINUE TO OPERATE IN THE STATE PRIOR TO POWER LOSS OF FAN OPERATION INDI- CATION	NO EFFECT, NEVER LOSE MORE THAN 1/2 OF THE TOTAL 36 FANS	NOTE 2
		TEA-055 TO 060 REA-055 TO 060 SEA-055 TO 060	SUPERVISORY CIRCUIT FOR CW-V-7,8,11 COOLING TOWER SUPPLY VALVES	MOV'S FAIL AS IS - WHICH MAY BE OPEN OR CLOSED. LOSS OF POSI- TION INDICATION	NONE.	NOTE 2
LP-6R-A	A	Teb 001 TO 054 REB 001 TO 054 SEB 001 TO 054	SUPERVISORY CIRCUIT CW-FN-1 TO 18	LOSS OF FAN CONTROL. FANS CONTINUE TO OPERATE IN THE STATE PRIOR TO POWER LOSS OF FAN OPERATION INDI- CATION	NO EFFECT, NEVER LOSE MORE THAN 1/2 OF THE TOTAL 36 FANS	NOTE 2
		TEB-055 TO 060 REB-055 TO 060 SEB-055 TO 060	SUPERVISORY CIRCUIT FOR CW-V-4,5,6 COOLING TOWER SUPPLY VALVES	MOV'S FAIL AS IS - WHICH MAY BE OPEN OR CLOSED. LOSS OF POSI- TION INDICATION	NONE.	NOTE 2



<u>BUS NUMBER</u>	<u>BUS DIV</u>	<u>DEVICE NUMBER</u>	<u>DEVICE DESCRIPTION</u>	<u>PRIMARY EFFECT ON DEVICE</u>	<u>PRIMARY EFFECT ON SYSTEM</u>	<u>ALARM POINT</u>
PP-7A-2	A	H13-P612 120V INSTR. BUS POWER	INSTRUMENT POWER FOR FEEDWATER CONTROL SYSTEM	LOSS OF FEEDWATER CONTROLLER SIGNALS. ALARM UNITS DEENER- GIZE, LOSS OF SIGNALS FORM INSTRUMENTS.	LOSS OF FEEDWATER CONTROL FOR RFW TURBINES. REACTOR RECIRC GOES TO LOW FLOW MODE.	1) ANNUNC. ON P603 "TURBINE RFP CON- TROL SIGNAL FAILURE." 2) REACTOR HI WATER LEVEL TRIP. 3) REACTOR LEVEL HI OR LO. 4) REACTOR PRESS HI. 5) VALVE CONTROL SIGNAL FAILURE.
PP-8A-F	2	SCS2-021 RCS2-021	RECEIVER AND RELAY FROM SW-LS-1B3	LOSS OF LOW WATER TRIP OF SW-P-1B	NONE.	BISI "SUPV SYS" TROUBLE "SSW B 005"
MC-1A	A	SS-V-41	BYPASS VALVE AROUND SS-V-39 (MOV)	MOV VALVE FAILS CLOSED. LOSS OF POSITION INDICATION.	NONE.	NOTE 2.
		RFW-V-109-T	HP HTRS BYPASS MOV	FAIL AS IS (N.C.) LOSS OF POSITION INDICATION	NONE.	LOSS OF POSITION IND. ON BD-T
		RFW-V-112A- A&T	PW OUTLET FROM HP HTR 6A-MOV	MOV FAILS AS IS (N.O.) POSITION INDICATION LOST	NONE ALL VALVES ALIGNED IN OPERATION	LOSS OF POSITION IND. ON BD-A AND BD-T
		RFW-V-108A-T	PW INLET TO HP HTR 6A	MOV FAILS AS IS (N.O.) POSITION INDICATION LOST	NONE ALL VALVES ALIGNED IN OPERATION POSITION	LOSS OF POSITION IND. ON BD-T.
		RFW-V-117A- A&T	CONDENSATE AND FEED- WATER CLEANUP RECIR- CULATION BLOCK VALVE	MOV VALVE FAILS AS IS (N.C.) POSITION INDICATION LOST	NONE.	LOSS OF POSITION IND. ON BD-A AND BD-T.
MC-1B	A	SS-V-6A SS-V-7A	SEAL STEAM TO RFW-DT-1A	MOV VALVES FAIL AS IS (N.O.) LOSS OF POSI- TION INDICATION	NONE.	NOTE 2.



<u>BUS NUMBER</u>	<u>BUS DIV</u>	<u>DEVICE NUMBER</u>	<u>DEVICE DESCRIPTION</u>	<u>PRIMARY EFFECT ON DEVICE</u>	<u>PRIMARY EFFECT ON SYSTEM</u>	<u>ALARM POINT</u>
		SS-V-8A	SEAL STEAM BYPASS TO RFW-DT-1A	MOV VALVE FAILS AS IS (N.C.) LOSS OF POSITION INDICATION	NONE.	NOTE 2.
		MD-P-1A	MISC DRAIN PUMP	LOSS OF POWER, CONTROL AND INDICATION	NONE, MD-P-1B WILL START ON HIGH TANK LEVEL IF MD-P-1A LOSES POWER	NOTE 2.
		MD-V-1A	MD-P-1A DISCHARGE VALVE	MOV FAILS OPEN AND LOSS OF POSITION INDICATION	NONE	NOTE 2.
		RFW-V-102A-A	RFP A DISCHARGE MOV	MOV FAILS AS IS (N.O.) POSITION INDICATION LOST	NONE	VALVE POSITION LOST ON BD-A
		RFP-TNG-1A	RFP-A-TURNING GEAR	INOPERABLE, LOSS OF IND.	REQUIRED AFTER FEED PUMP TURBINE TRIPS	NOTE 2.
		RFW-AOP-1A	AUXILIARY OIL PUMP FOR RFP TURBINE "A"	PUMP INOPERABLE, LOSS OF IND.	REQUIRED AFTER SECURING MAIN LUBE OIL PUMP	NOTE 2.
		RFP-MOP-1A	MAIN LINE OIL PUMP	PUMP 1A INOPERABLE, LOSS OF INDICATION	TRIPS RFW TURBINE A	NOTE 2.
MC-2C	B	RFW-V-117B	CONDENSATE AND FEED-WATER CLEANUP RECIRCULATION BLOCK VALVE	VALVE FAILS AS IS (N.C.) POSITION INDICATION LOST	NONE.	LOSS OF VALVE POSIT. INDICATION ON BD-T AND BD-A
		RFW-V-118	REACTOR STARTUP BYPASS VALVE BLOCK VALVE	MOV VALVE FAILS AS IS (N.O.) POSITION INDICATION LOST	NONE.	LOSS OF VALVE POSIT. INDICATION ON BD-T AND BD-A
MC-2C	B	RFW-V-112B	FW OUTLET FROM HP HTR 6B-MOV	MOV VALVE FAILS AS IS (N.O.) POSITION INDICATION LOST	NONE	LOSS OF VALVE POSIT. INDICATION ON BD-T AND BD-A



<u>BUS NUMBER</u>	<u>BUS DIV</u>	<u>DEVICE NUMBER</u>	<u>DEVICE DESCRIPTION</u>	<u>PRIMARY EFFECT ON DEVICE</u>	<u>PRIMARY EFFECT ON SYSTEM</u>	<u>ALARM POINT</u>
		RFW-V-108B	FW INLET TO HP HTR HTR 6B-MOV	MOV VALVE FAILS AS IS (N.O.) POSITION INDICATION LOST	NONE	LOSS OF VALVE POSIT. INDICATION ON BD-T AND BD-A
		SS-V-1A	SS EVAPORATOR SS-EV-1A DISCHARGE VALVE	MOV VALVE FAIL AS IS (N.O.) LOSS OF POSI- TION INDICATION	NONE.	NOTE 2
		SS-V-3B	EXCESS GLAND SEAL LEAKOFF VALVE	MOV VALVE FAILS AS IS (N.O.) LOSS OF POSI- TION INDICATION	NONE	NOTE 2
MC-2D	B	RFW-V-102B	RFP-B, DISCHARGE MOV	MOV FAILS AS IS, (N.O.) POSITION INDI- CATION LOST	NONE	LOSS OF POSIT. IND. ON BD-A
MC-2P	B	RFP-TNG-1B	RFP-B TURNING GEAR	INOPERABLE, LOSS OF IND.	REQUIRED AFTER TRIPPING RFP TURBINE	NOTE 2
		RFW-AOP-1B	AUXILIARY OIL PUMP FOR RFP TURBINE "B"	PUMP INOPERABLE LOSS OF IND.	REQUIRED AFTER SECUR- ING MAIN LUBE OIL PUMP	NOTE 2
		SS-V-6B SS-V-7B	SEAL STEAM TO RFW-DT-1B	MOV VALVES FAIL AS IS (N.O.) LOSS OF POSI- TION INDICATION	NONE	LOSS OF VALVE POSIT. IND. ON BD-A
		SS-V-8B	SEAL STEAM BYPASS TO RFW-DT-1B	MOV VALVES FAILS AS IS (N.C.) LOSS OF POSI- TION INDICATION	NONE	LOSS OF VALVE POSIT. IND. ON BD-A
		MD-P-1B	MISC DRAIN PUMP	LOSS OF POWER, CONTROL AND INDICATION	NONE, MD-P-1A WILL START ON HIGH TANK LEVEL IF MD-P-1B LOSES POWER	LOSS OF POS. IND. ON BD-T
MC-2P	B	MD-V-1B	MD-P-1B DISCHARGE VALVE	MOV FAILS OPEN AND LOSS OF POSITION INDICATION	NONE	LOSS OF POS. IND. ON BD-T

<u>BUS NUMBER</u>	<u>BUS DIV</u>	<u>DEVICE NUMBER</u>	<u>DEVICE DESCRIPTION</u>	<u>PRIMARY EFFECT ON DEVICE</u>	<u>PRIMARY EFFECT ON SYSTEM</u>	<u>ALARM POINT</u>
		RFP-MOP-1B	MAIN LUBE OIL PUMP	PUMP INOPERABLE LOSS OF INDICATION	TRIPS RFW TURBINE "B"	SEE RFW-AOP-1B ON SHEET 3
HC-7C	A	RFW-V-65A	RFW ISOLATION VALVE	MOV FAILS AS IS (N.O.) LOSS OF POSITION INDICATION	NONE	LOSS OF VALVE POSITION IND. ON P602
HC-8C	B	RFW-V-65B	RFW ISOLATION VALVE	MOV FAILS AS IS (N.O.) LOSS OF POSITION INDICATION	NONE	LOSS OF VALVE POSITION IND. ON P602
PP-8A-A	2	TT-Y-1B TT-Z-1B1	RFW TURBINE STOP VALVES RELAYS TO RFW-FSPV-2B	RELAYS DEENERGIZE AND DEENERGIZE RFW-FSPV-2B	RFW-FCV-2B DOES NOT CLOSE ON TRIP OF RFW-DT-1B BUT STILL HAS THROTTLING CAPABILITY	1) SEE PP-8A-A ON GROUP K SHEET 4 2) "RFP-1B TURBINE TRIP" 3) "RFP-1B TURBINE ALARMS
		RFW-FT-2B RFW-FIC-2B	RFW FLOW INDICATION AND MIN FLOW CONTROL	RFW-FCV-2B WILL GO FULL OPEN AND LOSS OF PUMP "B" FLOW INDICATION	FEED PUMPS WILL INCREASE FLOW TO 115% FLOW TO TRY TO MAINTAIN FEEDWATER FLOW TO VESSEL. REACTOR VESSEL LEVEL WILL DROP SLOWLY.	1) SEE PP-8A-A ON GROUP K SHEET 4 2) "RFP-1B TURBINE TRIP" 3) "RFP-1B TURBINE ALARMS
PP-7A-Z	A	RFT-GOV-1A	RFW FEED PUMP GOVERNOR	LOSS OF POWER TO GOVERNOR CAUSES AUTOMATIC TURBINE TRIP.		RFT-1A TURBINE TRIP ANNUNCIATOR
PP-8A-Z	B	RFT-GOV-1B	RFW FEED PUMP GOVERNOR	LOSS OF POWER TO GOVERNOR CAUSES AUTOMATIC TURBINE TRIP.		RFT-1B TURBINE TRIP ANNUNCIATOR
DP-S1-1C	A	RFW-DT-1A	RFW FEED PUMP	LOSS OF POWER RFW TURBINE TRIP CIRCUIT	FEEDWATER TURBINE 1A TRIPS	"TRIP CIRCUIT FAILURE" ANNUNCIATION
DP-S1-2C	B	RFW-DT-1B	RFW FEED PUMP	LOSS OF POWER RFW TURBINE TRIP CIRCUIT	FEEDWATER TURBINE 1B TRIPS	"TRIP CIRCUIT FAILURE" ANNUNCIATION

<u>BUS NUMBER</u>	<u>BUS DIV</u>	<u>DEVICE NUMBER</u>	<u>DEVICE DESCRIPTION</u>	<u>PRIMARY EFFECT ON DEVICE</u>	<u>PRIMARY EFFECT ON SYSTEM</u>	<u>ALARM POINT</u>
DP-S1-1C-1	A	RFW	RFW TURBINE EMERGENCY L.O. PUMPS	LOSS OF EMERGENCY CONTROLS FOR L.O. BOTH TURBINES	NONE	LOSS OF PUMP STATUS LIGHTS ON BD-A
PP-1B-A	A	TSW-TE-14A TSW-MV/1-142A TSW-1/P-142A TSW-TCV-14A	PLANT SERVICE WATER TCV TO RFW TURBINE OIL COOLERS	TSW-TCV-14A WILL CLOSE	OPERATOR SHOULD TRIP RFW TURBINE 1A ON HIGH OIL TEMP ALARM. TURBINE WILL EVENTUALLY TRIP ITSELF ON HIGH VIBRATION.	INCREASING TEMPERATURE AS INDICATED ON TSW-TI-14A ON BD-A.
		RFW-FSPV-2A	RFW SPV FOR RFW-FCV-2A MIN FLOW RECIRC VALVE	RFW-FCV-2A WILL OPEN AS FW FLOW DROPS OFF	RFW-FCV-2A DOES NOT CLOSE ON TRIP OF RFW-DT-1A BUT STILL HAS THROTTLING CAPABILITY	LOSS OF VALVE POSIT. ON BD-A
		99 TIX-1A	TURBINE SPEED SWITCH	TURBINE TRIP OF RFW-DT-1A LOSS OF SPEED INDICATION	LOSE FW PUMP 1A	NOTE 2
PP-2P-A	B	RFW-FSPV-2B	RFW SPV FOR RFW-FCV-2B MIN FLOW RECIRC VALVE	RFW-FCV-2B WILL OPEN AS FW FLOW DROPS OFF	RFW-FCV-2B DOES NOT CLOSE ON TRIP OF RFW-DT-1B BUT STILL HAS THROTTLING CAPABILITY	NOTE 2
		99 TIX-1B	TURBINE SPEED SWITCH	TURBINE TRIP OF RFW-DT-1B LOSS OF SPEED INDICATION	LOSE FW PUMP 1B	RFT TRIP WITH ALL ASSOC. ALARMS.
PP-2P-A	B	TSW-TE-14B TSW-MV/1-14B2 TSW-1/P-14B2 TSW-TCV-14B	PLANT SERVICE WATER TCV TO RFW TURBINE OIL COOLERS	TSW-TCV-14B WILL CLOSE	OPERATOR SHOULD TRIP RFW TURBINE 1B ON HIGH OIL TEMP ALARM. TURBINE WILL EVENTUALLY TRIP ITSELF ON HIGH VIBRATION	INCREASING TRIP AS INDICATED ON TSW-TI-14B ON BD-A

<u>BUS NUMBER</u>	<u>BUS DIV</u>	<u>DEVICE NUMBER</u>	<u>DEVICE DESCRIPTION</u>	<u>PRIMARY EFFECT ON DEVICE</u>	<u>PRIMARY EFFECT ON SYSTEM</u>	<u>ALARM POINT</u>
PP-7A-A	1	RFW-FT-2A RFW-FIC-2A	RFW-FLOW INDICATION AND MIN FLOW CONTROL	RFW-FCV-2A WILL GO FULL OPEN AND LOSS OF PUMP "A" FLOW INDICA- TION	FEED PUMPS WILL INCREASE FLOW TO 115% FLOW TO TRY TO MAIN- TAIN FEEDWATER FLOW TO VESSEL. REACTOR VESSEL LEVEL WILL DROP SLOWLY	1) SEE PP-7A-A ON GROUP F SHEETS 5&6 2) "RFT-1A TURBINE TRIP" 3) RFT-1A TURBINE ALARMS
		TT-Y-1A TT-Z-1A1	RFW-TURBINE STOP VALVES RELAYS TO RFW-FSPV-2A	RELAYS DEENERGIZE AND DEENERGIZE RFW-FSPV-2A	RFW-FCV-2A DOES NOT CLOSE ON TRIP OF RFW-DT-1A BUT STILL HAS THROTTLING CAPABILITY	1) SEE PP-7A-A ON GROUP F SHEETS 5&6 2) "RFT-1A TURBINE TRIP" 3) RFT-1A TURBINE ALARMS



<u>BUS NUMBER</u>	<u>BUS DIV</u>	<u>DEVICE NUMBER</u>	<u>DEVICE DESCRIPTION</u>	<u>PRIMARY EFFECT ON DEVICE</u>	<u>PRIMARY EFFECT ON SYSTEM</u>	<u>ALARM POINT</u>
HC-1A	A	MS-V-108A	MAIN STEAM SUPPLY TO SEAL STH EVAP.	MOV VALVE FAILS AS IS, (N.O.) POSITION INDICATION LOST	NONE.	LOSS OF VALVE POSITION INDICATION ON BD-B
		MS-V-110A	STEAM TO SJAE COND-HC-8A	MOV VALVE FAILS AS IS, (N.O.) POSITION INDICATION LOST	NONE.	LOSS OF VALVE POSITION INDICATION ON BD-B
		MS-V-70A	MSR TEMP CONTROL	MOV FAILS AS IS, N.O.	NONE.	LOSS OF VALVE POSITION INDICATION ON BD-B
		MS-V-146	MSR ISOL. VALVE	MOV FAILS AS IS, N.O.	NONE.	LOSS OF VALVE POSITION INDICATION ON BD-B
		HD-V-19A	STM EVAP TO LP HTR 5A	MOV FAILS AS IS, N.O. LOSS OF POSITION INDICATION	NONE.	NOTE 2
MC-1B	A	MS-V-105A	STEAM TO RFW-DT-1A	MOV FAILS AS IS, N.O. LOSS OF POSITION INDICATION	NONE.	LOSS OF VALVE POSITION INDICATION ON BD-A
MC-2C	B	MS-V-101B	MSR SECOND STAGE SHUTOFF VALVE	VALVE FAILS AS IS, N.O. POSITION INDICATION LOST	NONE.	LOSS OF POST IND. ON BD-B
		MS-V-70C	MSR TEMP CONTROL	MOV FAILS AS IS, N.O.	NONE.	LOSS OF POST IND. ON BD-B
HC-2D	B	MS-V-110B	STEAM TO SJAE COND-HC-8B	MOV FAILS AS IS, N.O.	NONE.	LOSS OF VALVE POSIT. IND. ON BD-B
		MS-V-105B	STEAM TO RFW-DT-1B	MOV FAILS AS IS, N.O.	NONE.	LOSS OF VALVE POSIT. IND. ON BD-A
MC-2R	B	HD-V-23A	STM EVAP TO LP HTR 5B	MOV FAILS AS IS, N.O. LOSS OF POSITION INDICATION	NONE.	NOTE 2

<u>BUS NUMBER</u>	<u>BUS DIV</u>	<u>DEVICE NUMBER</u>	<u>DEVICE DESCRIPTION</u>	<u>PRIMARY EFFECT ON DEVICE</u>	<u>PRIMARY EFFECT ON SYSTEM</u>	<u>ALARM POINT</u>
MC-2R	B	MS-V-103B	MSR SECOND STAGE SHUTOFF VALVE	MOV FAILS AS IS, (N.O.) LOSS OF POSITION INDICATION	NONE	LOSS OF VALVE POSIT. IND. ON BD-B
		MS-V-70D	MSR TEMP CONTROL	MOV FAILS AS IS, (N.O.) LOSS OF POSITION INDICATION	NONE.	LOSS OF VALVE POSIT. IND. ON BD-B
MC-3B	A	MS-V-103A	MSR SECOND STAGE SHUTOFF VALVE	MOV FAILS AS IS, (N.O.) LOSS OF POSITION INDICATION	NONE.	LOSS OF VALVE POSIT. IND. ON BD-B
		MS-V-70B	MSR TEMP CONTROL	MOV FAILS AS IS, (N.O.)	NONE.	LOSS OF VALVE POSIT. IND. ON BD-B
MC-3C	A	MS-V-110A	STEAM TO SJAE COND-11X-8A	MOV FAILS AS IS, (N.O.) LOSS OF POSITION INDICATION	NONE.	LOSS OF POSIT. IND. ON BD-B
PP-1B-A	A	MS-SPV-12A	CONTROL AIR TO MS-V-12A	MS-V-12A FAILS CLOSED- (N.C.) MS-V-13A FAILS CLOSED- (N.C.)	NONE.	LOSS OF POSIT. INDICATION FOR MS-V-12A; MS-PCV-11A; MS-PCV-12A; MS-PCV-13A ON BD-B
		MS-SPV-16A MS-SPV-17A	STEAM TO SJAE	MS-PCV-16A, 17A THROTTLE, THIS IS THEIR NORMAL POSITION	NONE.	LOSS OF POSITION IND. FOR BOTH VALVES ON BD-B
PP-2P-A	B	MS-SPV-12B	CONTROL AIR TO MS-V-12B	MS-V-12B FAILS CLOSED- (N.C.) MS-V-13B FAILS CLOSED- (N.C.)	NONE.	LOSS OF VALVE POSITION IND. FOR MS-PCV-11A, 12A, 13A AND MS-V-12B ON BD-B
		MS-SPV-16B MS-SPV-17B	STEAM TO SJAE	MS-PCV-16B, 17B THROTTLE; THIS IS THEIR NORMAL POSITION	NONE.	LOSS OF POSIT. IND. FOR BOTH VALVES ON BD-B



<u>BUS NUMBER</u>	<u>BUS DIV</u>	<u>DEVICE NUMBER</u>	<u>DEVICE DESCRIPTION</u>	<u>PRIMARY EFFECT ON DEVICE</u>	<u>PRIMARY EFFECT ON SYSTEM</u>	<u>ALARM POINT</u>
PP-3A-A	A	MS-SPV-115A MS-SPV-115B	CONTROL AIR TO MS-TCV-115A	MS-TCV-115A CLOSES	LOSE MAJOR PORTION OF 2ND STAGE HEATING ON MOISTURE SEPARATOR REHEATERS 1A & 1B	1) MAIN STEAM BYPASS STRAINER HI ΔP 2) LOSS OF VALVE POSITION INDICATION
			CONTROL AIR TO MS-TCV-115B	MS-TCV-115B CLOSES	LOSE MAJOR PORTION OF 2ND STAGE HEATING ON MOISTURE SEPARATOR REHEATERS 1A & 1B	1) MAIN STEAM BYPASS STRAINER HI ΔP 2) LOSS OF VALVE POSITION INDICATION
PP-2RA-B	B	MS-SPV-115C MS-SPV-115D	CONTROL AIR TO MS-TCV-115C	MS-TCV-115C CLOSES	LOSE MAJOR PORTION OF 2ND STAGE HEATING ON MOISTURE SEPARATOR REHEATERS 1A & 1B	1) MAIN STEAM BYPASS STRAINER HI ΔP 2) LOSS OF STEAM TRAP. BYPASS VALVE IND. ON BD-T
PP-7A-Z	A	MS-TC-115	CONTROLLER FOR MS-TCV-116A CONTROLLER FOR MS-TCV-116B CONTROLLER FOR MS-TCV-116C CONTROLLER FOR MS-TCV-116D	VALVES GO CLOSED	LOSE 2ND STAGE HEAT- ING ON MOISTURE SEPARATOR REHEATERS 1A AND 1B	
MC-8C-B	B	MS-V-1	REACTOR HEAD VENT	LOSS OF POSITION INDICATION ON P601 MOV FAILS AS IS, (N.C.)	NONE	NOTE 2.
	B	MS-V-2	REACTOR HEAD VENT	LOSS OF POSITION INDICATION MOV FAILS AS IS, (N.C.)	NONE	NOTE 2.
MC-8C-B	B	MS-V-5	REACTOR HEAD VENT	LOSS OF POSITION INDICATION OF P601 MOV FAILS AS IS (N.C.)	NONE	NOTE 2.

<u>BUS NUMBER</u>	<u>BUS DIV</u>	<u>DEVICE NUMBER</u>	<u>DEVICE DESCRIPTION</u>	<u>PRIMARY EFFECT ON DEVICE</u>	<u>PRIMARY EFFECT ON SYSTEM</u>	<u>ALARM POINT</u>
RPS 120 VAC	A	B22-F022 A,B,C,& D	MAIN STEAMLINE IN BOARD AOV	FAILS CLOSED IF BOTH SOL POWER IS LOST	SCRAMS REACTOR	
RPS 120 VAC	B	B22-F022 A,B,C,& D	MAIN STEAMLINE IN BOARD AOV	FAILS CLOSED IF BOTH SOL POWER IS LOST	SCRAMS REACTOR	
RPS 120 VAC	A	B22-F028 A,B,C,& D	MAIN STEAMLINE OUTBOARD AOV	FAILS CLOSED IF BOTH RPS BUSES ARE LOST	SCRAMS REACTOR	
RPS 120 VAC	B	B22-F028 A,B,C,& D	MAIN STEAMLINE OUTBOARD AOV	FAILS CLOSED IF BOTH RPS BUSES ARE LOST	SCRAMS REACTOR	
PP-7A-A	1	MS-FT-25A	FLOW DETECTION AND AIR REMOVAL ISOLATION LOGIC	AR-V-2A AND 2B OPEN, LOSS OF CONTROL FOR THESE VALVES	NORMALLY OPEN, IF THIS TRAIN IS OPERATING. NO EFFECT OTHERWISE	LOSS OF MOST BOP ANALOG LOOPS IN DIV 1 AND DIV A WITH ASSOCIATED ALARMS AND LOSS OF CONTROL AND INDICATION LOSS OF VOLTAGE IND. FOR PP-7A-A ON BD-C.
PP-8A-A	2	MS-FT-25B	FLOW DETECTION AND AIR REMOVAL ISOLATION LOGIC	AR-V-2C AND 2D OPEN, LOSS OF CONTROL FOR THESE VALVES	NORMALLY OPEN, IF THIS TRAIN IS OPERATING. NO EFFECT	1) LOSS OF MOST BOP ANALOG LOOPS IN DIV 2 AND DIV B WITH ASSOCIATED LOSS OF CONTROL AND INDICATION 2) LOSS OF VOLTAGE INDICATION FOR PP-8A-A ON BD-C.
USS-PP VIA DEH PWR DIST PANEL AL-2	A	MS-V-160A MS-V-160B MS-V-160C MS-V-160D	MS BYPASS VALVE SERVO ACTUATORS	LOSS OF PRESSURE CONTROL FUNCTION AFTER TURBINE TRIP. (BYPASS VALVES STILL OPEN ON TURBINE TRIP)	OPERATOR UNABLE TO CONTROL PRESS/TEMP RAMP DOWN RATE	LOSS OF VOLTAGE IND. ON US-PP VOLTMETER ON BD-C LOSS OF DIGITAL CONTROL SYSTEM
MC-7B	1	RRA-FN-12	DC MCC RM HVAC FAN UNIT	LOSS OF POWER & CONT. FOR FAN. LOSS OF CONT. RM & LOCAL INDICATION	LOSS OF VAC-S2-1A RCIC & RHR SHUTDOWN COOLING	RG 1.47 BISI "RRA-FN-12 PWR LOSS" "RCIC OUT-OF-SERVICE" DIV 1 "MOV NETWORK PWR LOSS/OL"
		ROA-SPV-12	DC MCC RM DAMPER OPERATOR SOL. VLV.	LOSS OF POWER TO SOL. VLV. WHICH CLOSES AIR DAMPER	LOSS OF NORMAL HVAC FOR MCC RM	"DC MCC RM AQA-AO-12 INLET DAMPER CLOSE"



<u>BUS NUMBER</u>	<u>BUS DIV</u>	<u>DEVICE NUMBER</u>	<u>DEVICE DESCRIPTION</u>	<u>PRIMARY EFFECT ON DEVICE</u>	<u>PRIMARY EFFECT ON SYSTEM</u>	<u>ALARM POINT</u>
MC-7B	1	E51-C003	WATER LEG PUMP	LOSS OF PUMP	NONE.	1) "RCIC-P-3 PWR LOSS" LIGHT 2) "RCIC DIV 1 OUT OF SERVICE" ANNUNC.
MC-7B-A	1	E12-F006A	RHR PUMP "A" SHUTDOWN COOLING SUCTION VALVE	MOV FAILS AS IS (NC) LOSS OF POS. IND.	SUCTION TO "A" LOOP LOST	1) "MOV NETWORK PWR LOSS/OL" LIGHT 2) "RHR A/LPCS OUT OF SERVICE" ANNUN.
		E12-F053B	RHR PUMP "B" S/D COOLING DISCH. VALVE	MOV FAILS AS IS (NC) LOSS OF POS. IND.	LOSS OF LOOP "B"	1) "MOV NETWORK PWR LOSS/OL" LIGHT 2) "NS4 DIV 1 OUT OF SERVICE" ANNUN.
		E12-F053A	RHR PUMP "A" S/D COOLING DISCH VALVE	MOV FAILS AS IS (NC) LOSS OF POS. IND.	LOSS OF LOOP "A"	1) "MOV NETWORK PWR LOSS/OL" LIGHT 2) "NS4 DIV 1 OUT OF SERVICE" ANNUN.
MC-8B-A	2	E12-F009	RHR S/D COOLING SUCTION VALVE	MOV FAILS AS IS (NC) LOSS OF POS. IND.	LOOP A AND B LOST FROM VESSEL	1) "MOV NETWORK PWR LOSS/OL" LIGHT 2) "NS4 DIV 2 OUT OF SERVICE" ANNUN.
		E12-F006B	RHR PUMP "B" S/D COOLING SUCTION VALVE	MOV FAILS AS IS (NC) LOSS OF POS. IND.	SUCTION TO "B" LOOP LOST	1) "MOV NETWORK PWR LOSS/OL" LIGHT 2) "RHR B AND C OUT OF SERVICE" ANNUN.
MC-S2-1A	1	E12-F008	RHR S/D COOLING SUCTION VALVE	MOV FAILS AS IS (NC) LOSS OF POS. IND.	LOOP A AND B LOST FROM VESSEL	1) "MOV NETWORK PWR LOSS/OL" LIGHT 2) "NS4 DIV 1 OUT OF SERVICE" ANNUN.
DP-S1-1D	1	E12-F008	RHR S/D COOLING SUCTION VALVE	MOV FAILS AS IS (NC) LOSS OF POS. IND.	LOOP A AND B LOST FROM VESSEL	1) "MOV NETWORK PWR LOSS/OL" LIGHT 2) "NS4 DIV 1 OUT OF SERVICE" ANNUN.

<u>BUS NUMBER</u>	<u>BUS DIV</u>	<u>DEVICE NUMBER</u>	<u>DEVICE DESCRIPTION</u>	<u>PRIMARY EFFECT ON DEVICE</u>	<u>PRIMARY EFFECT ON SYSTEM</u>	<u>ALARM POINT</u>
SM-7	D1	E12-C002A	RHR PUMP "A"	PUMP INOPERABLE	LOOP "A" OF RHR LOOP LOST	1) BUS SM-7 UV ANNUNC. 2) CB RHR-2A TRIPPED ANNUNC. 3) CB RHR-2A OUT OF SERVICE LIGHT ON P601 4) RHR LOOP "A" OUT OF SERVICE ANNUNC.
SM-7	1	SW-P-1A	STANDBY SERVICE WATER PUMP	LOSS OF PUMP POWER	LOSS OF RHR "A" HEAT EXCHANGER AND CRITICAL DIV 1 HVAC	BKR TRIP AND UNDER-VOLTAGE ANNUNC.
DP-S1-1A	1	H13-P629 125 VDC	CONTROL CKT FEED TO RELAY LOGIC FOR RHR "A" VALVE AND PUMP CONTROL	VALVE AUTO CKTS WILL FAIL. VALVES WILL NOT OPEN OR CLOSE. PUMP WILL NOT AUTO START.	LOSS OF RHR LOOP "A"	1) "RELAY LOGIC "A" PWR FAILURE" ANNUN. 2) "LPCS/RHR A LOGIC PWR FAIL" LIGHT 3) "RHR A/LPCS OUT OF SERVICE" ANNUN.
DP-S1-1D	1	125 VDC TO SM-7 SWGR	C002A SWGR BREAKER CONTROL VOLTAGE	PUMP MOTOR WILL NOT HAVE TRIPPING OR CLOSING CONTROL VOLTAGE	PUMP INOPERABLE, LOSS OF RHR LOOP "A"	1) "CB-RHR" 2A OUT OF SERVICE" LIGHT 2) "RHR A/LPCS OUT OF SERVICE" ANNUN.
DP-S1-1D	1	125 VDC CON- TROL PWR TO SM-7	SW-P-1A BREAKER CONTROL VOLTAGE	PUMP MOTOR WILL NOT HAVE TRIPPING OR CLOSING CONTROL VOLTAGE. LOSS OF INDICATOR LIGHTS	NO BREAKER CLOSURE LOSS OF RHR "A" AND CRITICAL DIV 1 HVAC	RG 1.47 BISI "BKR CB-SWIA OUT OF SERVICE (SSW "A" OUT OF SERVICE" NOTE 2
RPS BUS A C72-P001		H13-P623 120V REACTOR PROTECTION, BUS "A"	RHR OUTBOARD VALVE CONTROL RELAY FEED	LOSS OF P008 OPENING MODE. FAILS VALVE AUTO CONTROL CIRCUITRY AND CLOSSES VALVE	RHR S/D COOLING SUC- TION FROM RECIRC LINE LOST	REACTOR SCRAM
PP-7A-G	1	TS1-21	TRANSMITTER FOR SW-LS-1A3	LOSS OF INTERLOCK TO SW-P-1A AND SW-V-2A FOR LOW WATER LEVEL	NONE.	BISI "SUPV SYS TROUBLE" "SSW "A" OUT-OF-SERVICE"



<u>BUS NUMBER</u>	<u>BUS DIV</u>	<u>DEVICE NUMBER</u>	<u>DEVICE DESCRIPTION</u>	<u>PRIMARY EFFECT ON DEVICE</u>	<u>PRIMARY EFFECT ON SYSTEM</u>	<u>ALARM POINT</u>
PP-7A-G	1	TS1-003 TS1-004 TS1-001 TS1-002 TS1-022 TS1-031	TRANSMITTERS FOR SW-V-2A POS. SWITCHES	RECEIVERS IN CONTROL ROOM WILL NOT CHANGE STATE. POS. INDICATION AND INTERLOCK TO SW-P-1A & SW-PCV-38A WILL NOT CHANGE	LOSS OF INTERLOCK TO SW-PCV-38A, KEEPING THIS VALVE CLOSED LOSS OF SSW "A" LOOP	"STANDBY SW "A" SUPV SYSTEM TROUBLE" "SSW A OUT-OF-SERVICE"
PP-7A-G	1	TS1-013 TS1-014 TS1-015 TS1-016 TS1-017 TS1-024	TRANSMITTER FOR SW-V-12A POS. SWITCHES	RECEIVERS IN CONTROL ROOM WILL NOT CHANGE STATE, POS. INDICATION WILL NOT CHANGE	NONE.	"SSW A SUPV. SYSTEM TROUBLE" "SSW A OUT-OF-SERVICE"
PP-7A-G	1	SW-SPV-38A	SOLENOID VALVE FOR SW-PCV-38A, BACK PRESSURE CONTROL VALVE	SOLENOID VALVE WILL DEENERGIZE AND SW-PCV-38A WILL THROTTLE OPEN	NONE.	NONE.
		TS1-037 TS1-038 RS1-006 RS1-007 SS1-006 SS1-007	TRANSMITTERS FOR SW-PCV-38A POS. IND. RECEIVES AND SUPV. RELAYS FOR CONTROL OF SW-SPV-38A	SOLENOID VALVE WILL DEENERGIZE AND SW-PCV-38A WILL THROTTLE OPEN. POS. IND. WILL NOT CHANGE	NONE.	"SSW A SUPV. SYSTEM TROUBLE" "SSW A OUT-OF-SERVICE"
PP-7A-G	1	TS1-005 TS1-006 TS1-007 TS1-008 TS1-020 TS1-032	TRANSMITTERS FOR SW-V-69A POS. SWITCH	RECEIVERS IN CONTROL ROOM WILL NOT CHANGE STATE. POS. INDICATOR WILL NOT CHANGE	NONE.	"SSW A SUPV. SYSTEM TROUBLE" "SSW A OUT-OF-SERVICE"
PP-7A-G	1	TS1-009 TS1-010 TS1-011 TS1-012 TS1-023 TS1-033	TRANSMITTER FOR SW-V-70B POS. SWITCHES	RECEIVERS IN CONTROL ROOM WILL NOT CHANGE STATE. POS. INDICATOR WILL NOT CHANGE	NONE.	"SSW A SUPV. SYSTEM TROUBLE" "SSW A OUT-OF-SERVICE"

<u>BUS NUMBER</u>	<u>BUS DIV</u>	<u>DEVICE NUMBER</u>	<u>DEVICE DESCRIPTION</u>	<u>PRIMARY EFFECT ON DEVICE</u>	<u>PRIMARY EFFECT ON SYSTEM</u>	<u>ALARM POINT</u>
PP-7A-G	1	TS1-026 TS1-061 TS1-062 SS1-004 SS1-005 RS1-004 RS1-005	TRANSMITTERS FOR CONTROL OF PRA-FN-1A SUPV. RELAYS AND RECEIVERS FOR LOCAL OPERATING INDICATION	RECEIVERS IN CONTROL ROOM WILL NOT CHANGE STATE (FAN WOULD AUTOMATICALLY OPERATE) SUPV. RELAYS WOULD DEENERGIZE AND LOSS OF LOCAL POS. IND.	NONE.	"SSW A SUPV. SYSTEM TROUBLE" "SSW A OUT-OF-SERVICE"
PP-7A-A	1	SCS1-021 RCS1-21	RECEIVER AND RELAYS FROM SW-LS-1A3	LOSS OF INTERLOCK TO SW-P-1A AND SW-V-2A FOR LOW WATER LEVEL	NONE.	BISI "SUPV SYSTEM TROUBLE" "SSW A OUT-OF-SERVICE"
PP-7A-A	1	RSC1-003 RCS1-004 RCS1-001 RCS1-002 RCS1-022 RCS1-031 SCS1-003 SCS1-004 SCS1-001 SCS1-002 SCS1-022 SCS1-031	SUPV. RELAYS AND RECEIVERS FOR SW-V-2A POS. SWITCHES	SUPV. RELAYS DEENERGIZE. LOSS OF POS. INDICATION AND VALVE WILL FAIL-AS-IS (N.C.)	LOSS OF SSW LOOP A	"STANDBY SW A SUPV. SYSTEM TROUBLE" "SSW A OUT-OF-SERVICE" NOTE 2
PP-7A-A	1	RCS1-013 RCS1-014 RCS1-015 RCS1-016 RCS1-017 RCS1-024 SCS1-013 SCS1-014 SCS1-015 SCS1-016 SCS1-017 SCS1-024	SUPV. RELAYS AND RECEIVERS FOR SW-V-12A POS. SWITCHES	SUPV. RELAYS DEENERGIZE LOSS OF POS. INDICATION AND VALVE WILL FAIL-AS-IS (N.C.)	LOSS OF SSW "A" RETURN TO SPRAY POND "B", BUT RETURN TO COOLING TOWERS REMAINS OPERABLE	"SSW A SUPV. SYSTEM TROUBLE" "SSW A OUT-OF-SERVICE" NOTE 2