

Attachment A

Revise the Technical Specification pages as follows:

Remove

3.5-2

3.5-4

3.5-20

3.5-21

3.5-22

4.12-2

Insert

3.5-2

3.5-2a

3.5-4

3.5-4a

3.5-4b

3.5-20

3.5-20a

3.5-21

3.5-22

4.12-2

8802160174 880208  
PDR ADDCK 05000244  
P PDR

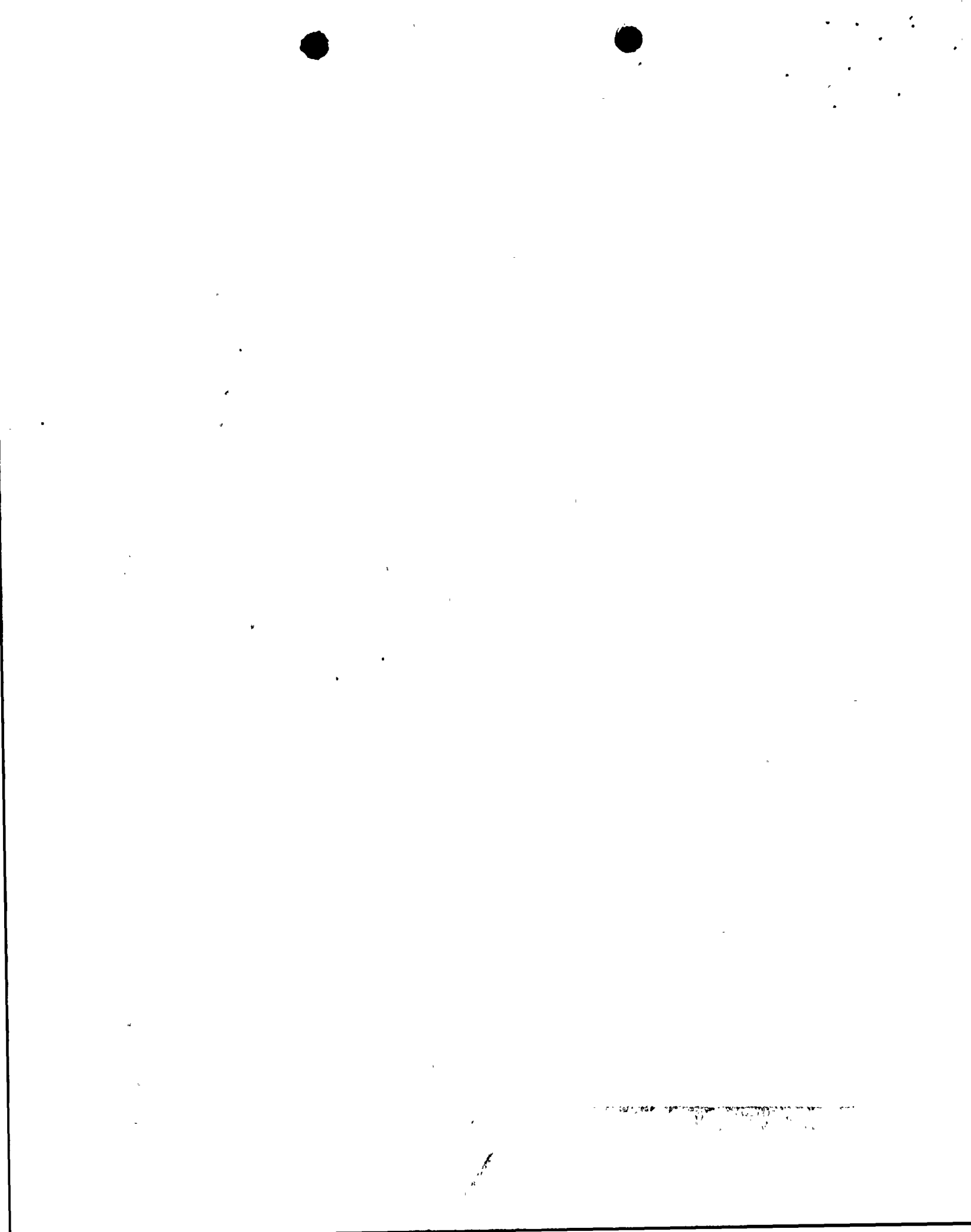

3.5.3.2 When required by 3.5.3.1, with the number of operable accident monitoring instrumentation channels less than the Total Number of Channels shown in Table 3.5-3, either restore the inoperable channel(s) to operable status within 7 days, or be in at least hot shutdown within the next 12 hours.

3.5.3.3 When required by 3.5.3.1, with the number of operable accident monitoring instrumentation channels less than the Minimum Channels Operable requirements of Table 3.5-3 either restore the inoperable channel(s) to operable status within 48 hours or be in at least hot shutdown within the next 12 hours.

3.5.4 The radiation accident monitoring instrumentation channels shown in Table 3.5-6 shall be operable, whenever the reactor is at or above hot shutdown. With one or more radiation monitoring channels inoperable, take the action shown in Table 3.5-6. Startup may commence or continue consistent with the action statement.

3.5.5 Radioactive Effluent Monitoring Instrumentation

3.5.5.1 The radioactive effluent monitoring instrumentation shown in Table 3.5-5 shall be operable at all times with alarm and/or trip setpoints set to insure that the limits of Specification 3.9.1.1 and 3.9.2.1 are not exceeded. Alarm and/or trip setpoints shall be established in accordance with calculational methods set forth in the Offsite Dose Calculation Manual.

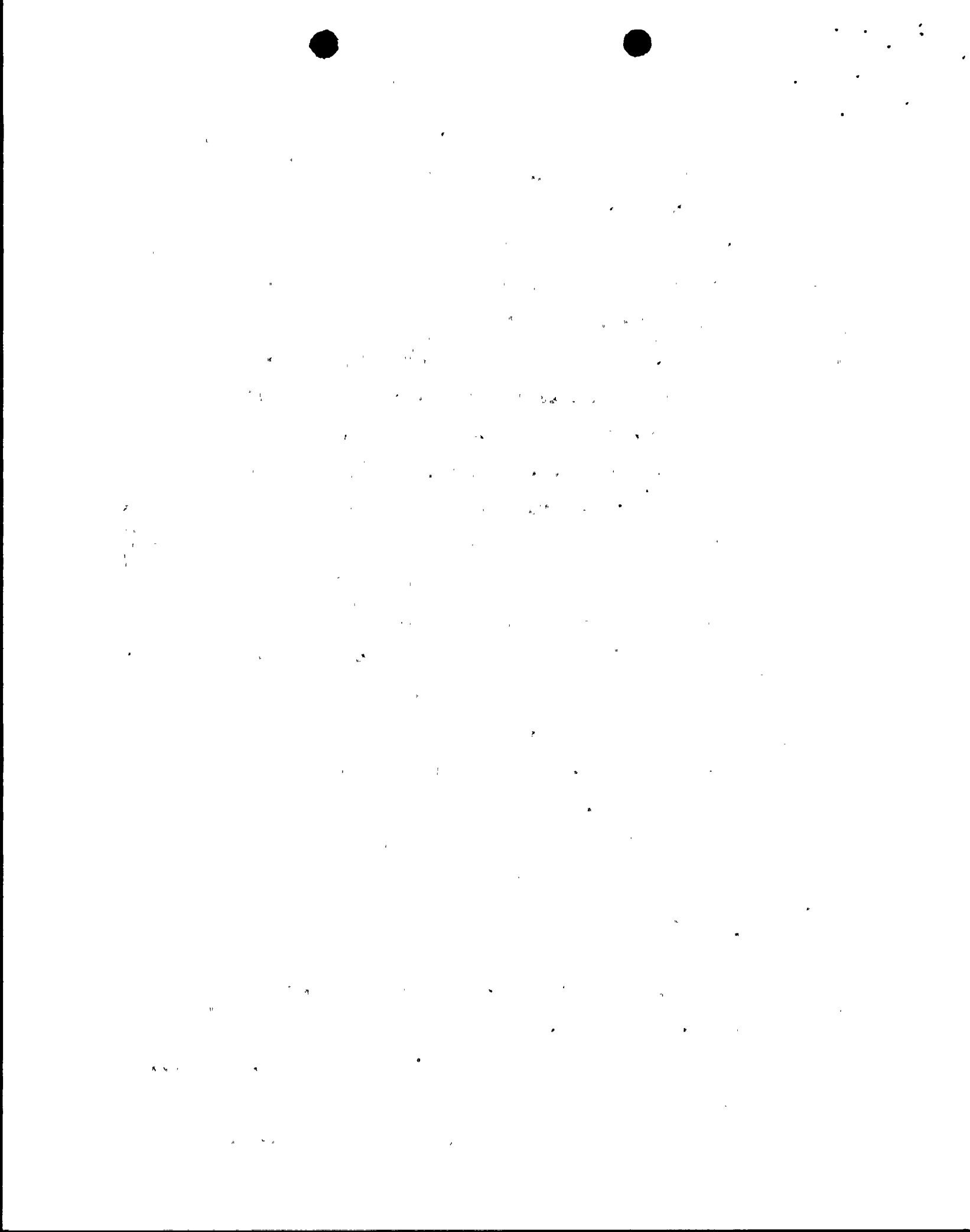

3.5.5.2 If the setpoint for a radioactive effluent monitor alarm and/or trip is found to be higher than required, one of the following three measures shall be taken immediately:

- (i) the setpoint shall be immediately corrected without declaring the channels inoperable; or
- (ii) immediately suspend the release of effluents monitored by the effected channel; or
- (iii) declare the channel inoperable.

3.5.5.3 If the number of channels which are operable is found to be less than required, take the action shown in Table 3.5-5. Exert best efforts to return the instruments to OPERABLE status within 31 days and, if unsuccessful, explain in the next Semiannual Radioactive Effluent Release Report why the inoperability was not corrected in a timely manner.

3.5.6 Control Room HVAC Detection Systems

3.5.6.1 During all modes of plant operation, detection systems for chlorine gas, ammonia gas and radioactivity in the control room HVAC intake shall be operable with setpoints to isolate air intake adjusted as follows:

The radioactive gaseous effluent instrumentation is provided to monitor and control, as applicable, the releases of radioactive materials in gaseous effluents. The alarm and/or trip setpoints for these instruments are calculated in accordance with the ODCM to ensure that alarm and/or trip will occur prior to exceeding the limits of 10 CFR Part 20. This instrumentation also includes provisions for monitoring the concentrations of potentially explosive gas mixtures in the waste gas holdup system. The operability and use of this instrumentation is consistent with the requirements of General Design Criterion 64 of Appendix A to 10 CFR Part 50.

Control Room HVAC detection systems are designed to prevent the intake of chlorine, ammonia and radiation at concentrations which may prevent plant operators from performing their required functions. Concentrations which initiate isolation of the control room HVAC system have been established using the guidance of several established references (2-4).

The chlorine isolation setpoint is 1/3 of the toxicity limit of reference 2 but slightly greater than the short term exposure limit of reference 4. The ammonia setpoint is established at approximately 1/3 of the toxicity limit for anhydrous ammonia in reference 2 and equal to the short term exposure limit of reference 4. The setpoints for radioactivity correspond to the

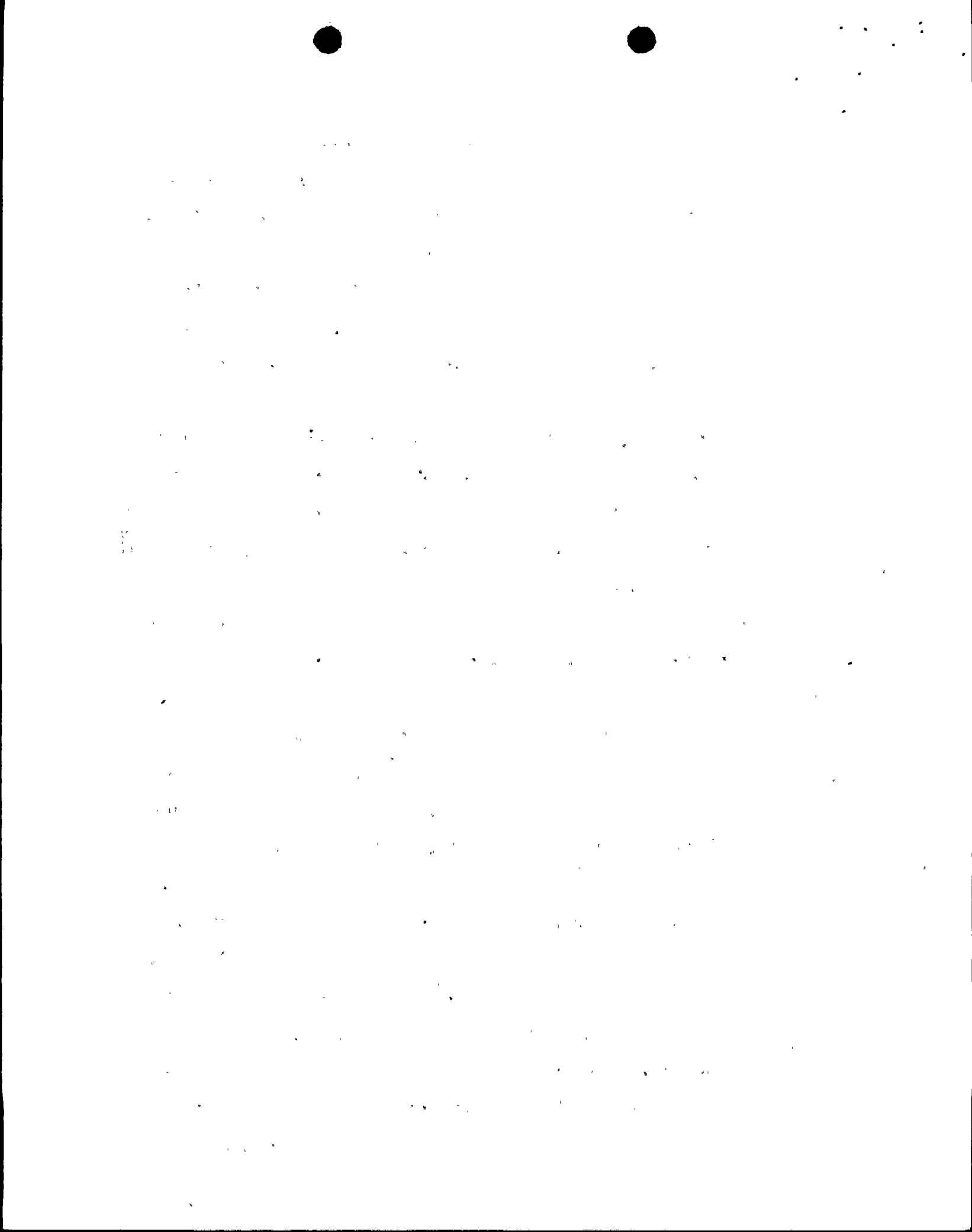

## References

- 1) Updated FSAR - Section 7.2.
- 2) USNRC Regulatory Guide 1.78, June 1974, Assumptions for Evaluating the Habitability of a Nuclear Power Plant Control Room During a Postulated Hazardous Chemical Release.
- 3) 10 CFR 20 Appendix B, Table I.
- 4) Threshold Limit Values for Chemical Substances and Physical Agents in the Work Environment, 1982. Published by American Conference of Governmental Industrial Hygienists.



maximum permissible concentrations of reference 3 for Cs-137, I-131 and Kr-85.

The mini-purge system is connected to the plant vent. 10 CFR Part 100 type releases via mini-purge are limited by an isolation signal generated from SI. 10 CFR Part 20 releases from mini-purge are considered to be similar to other plant ventilation releases and are monitored by R-10B, R-13, and R-14. R-14A may be a substitute for R-10B. Automatic isolation of mini-purge for 10 CFR Part 20 type releases is considered unnecessary due to the low flow associated with mini-purge and the continuous monitoring. However, the automatic isolation provisions using R11 or R12 provide additional margin for 10 CFR Part 20 type releases. Therefore, R-11 or R-12 is required to sample containment during mini-purge operation. To ensure the containment sample monitored by R-11 or R-12 is representative of the containment atmosphere, at least one recirculation fan is required to be in operation during mini-purge operation. Should R-11 and/or R-12 become inoperable, a 1 hour limit is chosen to be consistent with the generally accepted time for prompt action.

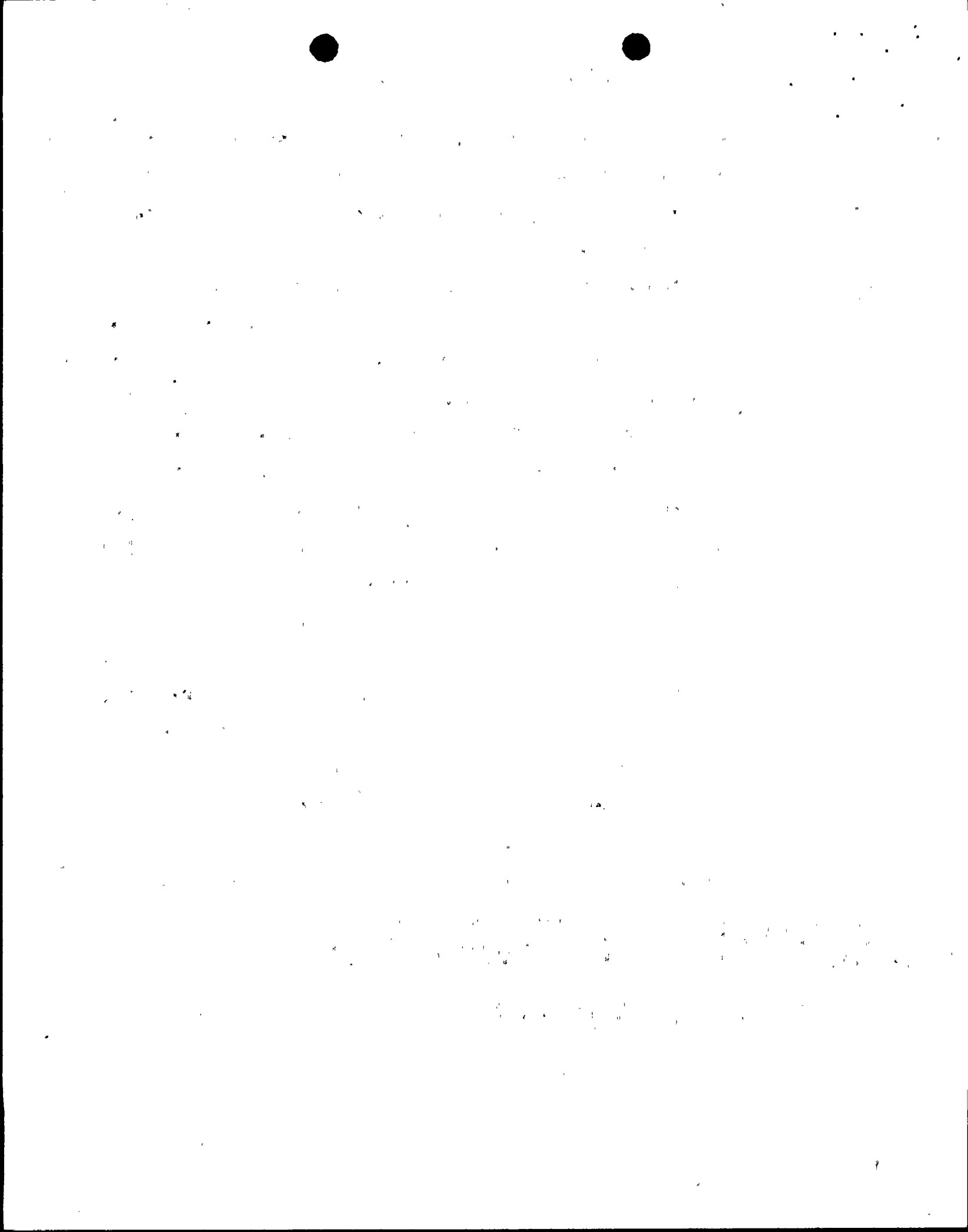

TABLE 3.5-5  
Radioactive Effluent Monitoring Instrumentation

	<u>Minimum Channels Operable</u>	<u>Action</u>
1. Gross Activity Monitors (Liquid)		
a. Liquid Radwaste (R-18)	1	1
b. Steam Generator Blowdown (R-19)	1*	2
c. Turbine Building Floor Drains (R-21)	1	3
d. High Conductivity Waste (R-22)	1	1
e. Containment Fan Coolers (R-16)	1	3
f. Spent Fuel Pool Heat Exchanger (R-20)	1	3
2. Plant Ventilation		
a. Without Mini-Purge		
1. Noble Gas Activity (R-14) (Providing Alarm and Isolation of Gas Decay Tanks)	1	4
2. Particulate Sampler (R-13)	1	5
3. Iodine Sampler (R-10B or R-14A)	1	5
b. With Mini-Purge		
1. Noble Gas Activity (R-14)	1	4
2. Particulate Sampler (R-13)	1	5
3. Iodine Sampler (R-10B or R-14A)	1	5
4. Noble Gas Activity (R-12) or Particulate Sampler (R-11)	1++	8
3. Shutdown Purge		
a. Noble Gas Activity (R-12)	1+	8
b. Particulate Sampler (R-11)	1+	8

	<u>Minimum Channels Operable</u>	<u>Action</u>
c. Iodine Sampler (R-10A or R-12A)***	1+	5
4. Air Ejector Monitor (R-15 or R-15A)***	1**	6
5. Waste Gas System Oxygen Monitor	1	7

\* Not required when Steam Generator Blowdown is being recycled (i.e. not released).

+ Required only during shutdown purges and required to sample the containment stack.

++ Required to sample containment during mini-purge operation.

\*\* Not required during Cold or Refueling Shutdown.

\*\*\* See Table 3.5-6

TABLE 3.5-5 (Continued)

Table Notation

Action 1 - If the number of operable channels is less than required by the Minimum Channels Operable requirement, effluent releases from the tank may continue for up to 14 days, provided that prior to initiating a release:

1. At least two independent samples of the tank's contents are analyzed, in accordance with Specification 4.12.1.1.a, and
2. At least two technically qualified members of the Facility Staff independently verify the release rate calculations and discharge line valving;

Otherwise, suspend release of radioactive effluents via this pathway.

Action 2 - When Steam Generator Blowdown is being released (not recycled) and the number of channels operable is less than required by the Minimum Channels Operable requirements, effluent releases via this pathway may continue provided grab samples are analyzed for gross radioactivity (beta or gamma) at a limit of detection of at most  $10^{-7}$  uCi/gram:

1. At least once per 8 hours when the concentration of the secondary coolant is  $> 0.01$  uCi/gram dose equivalent I-131.
2. At least once per 24 hours when the concentration of the secondary coolant is  $\leq 0.01$  uCi/gram dose equivalent I-131.

Action 3 - If the number of operable channels is less than required by the Minimum Channels operable requirement, effluent releases via this pathway may continue provided that at least once per 24 hours grab samples are analyzed for gross radioactivity (beta or gamma) at a limit of detection of at most  $10^{-7}$  uCi/gm.

Action 4 - If the number of operable channels is less than required by the Minimum Channels Operable requirement, effluent releases via this pathway may continue provided grab samples are taken at least once per 8 hours and these samples are analyzed for isotopic activity within 24 hours or R14A is operable and readings are reviewed at least once per 8 hours.

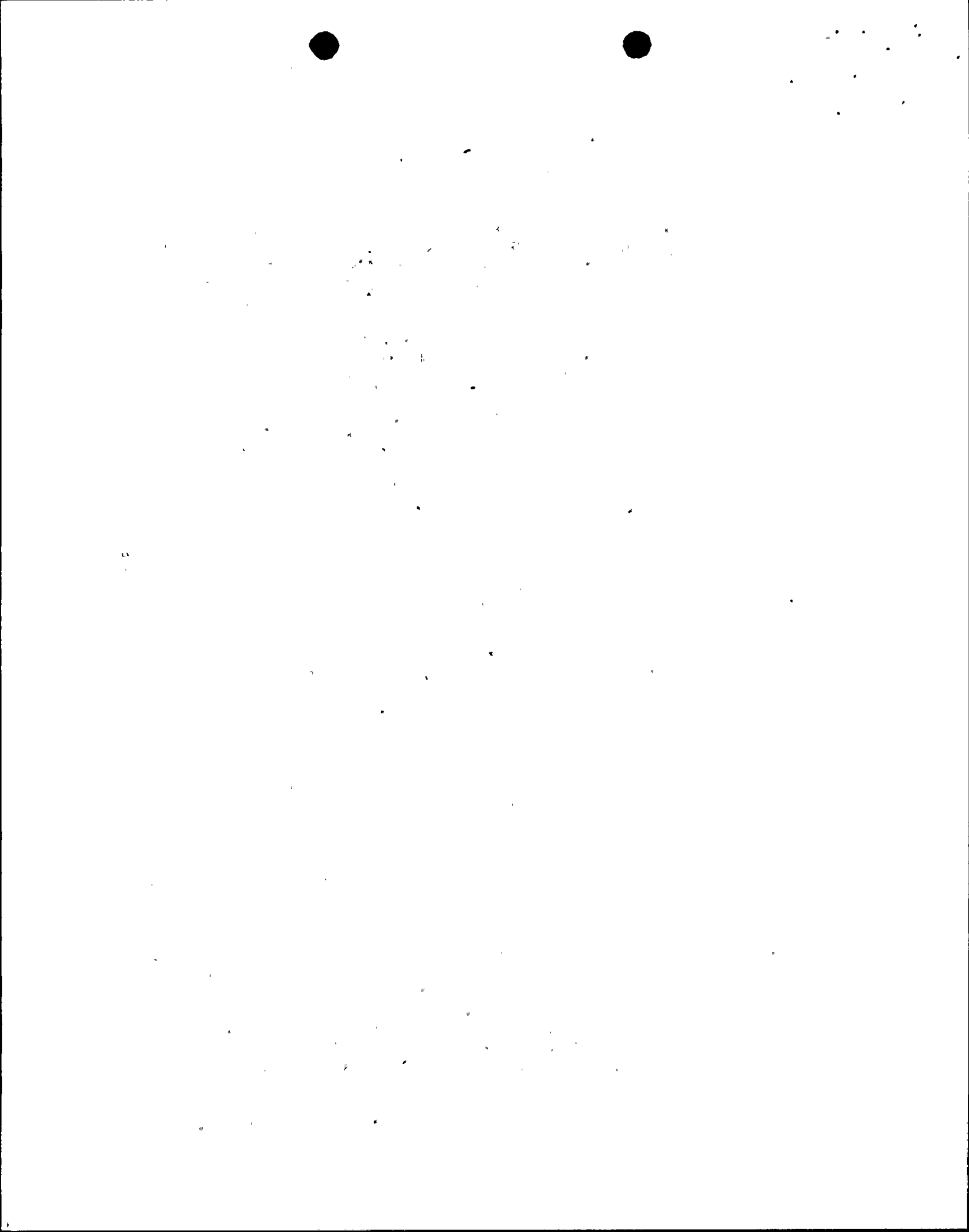
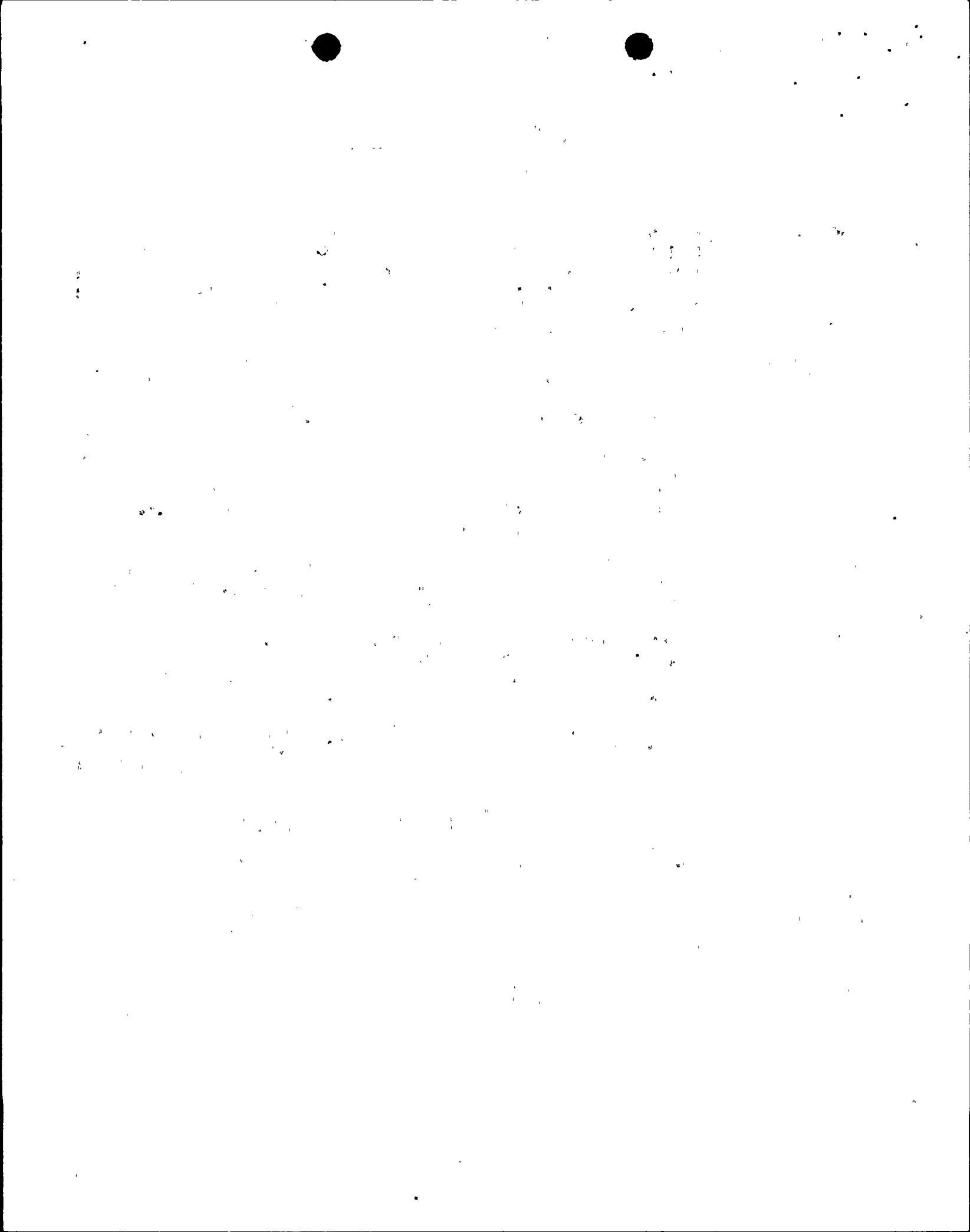

TABLE 3.5-5 (Continued)

Table Notation

- Action 5 - If the number of operable channels is less than required by the Minimum Channels Operable requirements, effluent releases via this pathway may continue provided samples are continuously collected as required by Table 4.12-2 Item E with auxiliary sampling equipment.
- Action 6 - If the number of operable channels is less than required by the Minimum Channels Operable and the Secondary Activity is  $\leq 1 \times 10^{-4}$  uCi/gm, effluent releases may continue via this pathway provided grab samples are analyzed for gross radioactivity (beta or gamma) at least once per 24 hours. If the secondary activity is greater than  $1 \times 10^{-4}$  uCi/gm, effluent releases via this pathway may continue for up to 31 days provided grab samples are taken every 8 hours and analyzed within 24 hours.
- Action 7 - If the channel is inoperable, a sample of the gas from the in service gas decay tank shall be analyzed for oxygen content at least once every 4 hours.
- Action 8 - If the number of operable channels is less than required by the Minimum Channels Operable, or at least one containment fan cooler is not operating, within 1 hour terminate the purge.





- 4.12.1.2.a Cumulative dose contributions from liquid effluents shall be determined in accordance with the ODCM at least once per 31 days.
- 4.12.2 Gaseous Wastes
  - 4.12.2.1 Release Rate
    - 4.12.2.1.a The effluent continuous monitors as listed in Table 3.5-6 having provisions for the automatic termination of gas decay tank, shutdown purge or mini-purge releases, shall be used to limit releases within the values established in Specification 3.9.2.1 when monitor setpoint values are exceeded.
    - 4.12.2.1.b The dose rate due to radioactive materials, other than noble gases, in gaseous effluents shall be determined in accordance with the methods of the ODCM by obtaining representative samples and performing analyses in accordance with the sampling and analysis program, specified in Table 4.12-2.
  - 4.12.2.2 Dose (10 CFR Part 50, Appendix I); Gaseous Waste Treatment.
    - 4.12.2.2.a Cumulative dose contributions from gaseous effluents shall be determined in accordance with the ODCM at least once every 31 days.
- 4.12.3 Waste Gas Decay Tanks

The quantity of radioactive material contained in each waste gas decay tank shall be determined to be

## Attachment B

In February 1986 a Technical Specification change was approved that allowed operation of a mini-purge system at Ginna. The old 48 inch containment purge system was sealed with blank flanges that can only be removed at cold or refueling shutdown. The 48 inch system, now called shutdown purge, is only operated during cold or refueling shutdown and exhausts into the containment vent. The new mini-purge system is designed to pass through charcoal and HEPA filters and to exhaust into the plant vent. Since the two systems will exhaust into different places Technical Specification Table 3.5-6 item 3 must be changed to cover operation of the mini-purge system. Details of the Technical Specification changes are presented on Table 1. A functional diagram of the radiation monitors is presented on Figure 1.

A review of the Ginna UFSAR Sections 6.2 and 11.5 indicates that 10 CFR Part 100 type releases are limited by an isolation signal generated by safety injection. 10 CFR Part 20 type releases for continuous processes are monitored and an alarm is generated if the setpoint is exceeded but there is no automatic isolation required. 10 CFR Part 20 releases for batch processes such as a gas decay tank releases or purge releases are automatically isolated since these sources may be higher concentrations than the concentrations associated with continuous processes.

Monitors R-11 and R-12 generate isolation signals for mini-purge and shutdown purge. R-11 and R-12 can monitor either containment or the containment vent. When monitoring the containment, both R-11 and R-12 are sensitive to increases in reactor coolant leakage. Because the mini-purge discharges to the plant vent, R-11 or R-12 is aligned to monitor containment during mini-purge operation to ensure an isolation signal is generated if necessary to limit releases below 10CFR20. Should the channel being used to monitor containment become inoperable (R11 or R12) mini-purge should be terminated within 1 hour. The 1 hour was chosen to be consistent with the generally accepted time for prompt action.

The following monitors are required for mini-purge operation: R-12 or R-11 provide mini-purge isolation if high concentrations of radioactivity are detected inside containment. Noble gas monitor R-12 and particulate monitor R-11 generate an isolation signal when their setpoint is exceeded. Iodine sampler R-10A generates an alarm when its setpoint is exceeded but does not generate an isolation signal. R-14, R-13, R-10B and R-14A will provide an equivalent level of protection for mini-purge releases as currently exists for plant ventilation releases.

Monitor R-12A is no longer allowed to be substituted for R-10A during mini-purge operation because R-12A only monitors the containment vent. Since mini-purge is connected to the plant vent, R-12A would not be monitoring mini-purge and therefore is not an acceptable substitute.

Since mini-purge is connected to the plant vent and the mini-purge flow is small compared to shutdown purge air flow or the plant ventilation air flow, mini-purge will be operated under the plant ventilation requirements and will also require an automatic isolation capability for releases.

In addition, specifying at least one recirculation fan running during mini-purge operation will ensure the sample being monitored by R-11 and R-12 is representative of the atmosphere being released through mini-purge.

A clarification has been made to specify the required action should the 31 day period specified in Actions 2,3,4 and 5 to Table 3.5-5 be exceeded. Consistent with draft Standard Technical Specifications, releases may continue beyond the 31 days provided notification is made via the Semiannual Radioactive Effluent Release Report. This action is acceptable because Action Statements 2,3,4 and 5 require alternative monitoring of the releases. This alternative monitoring will continue until the affected monitor is made operable. This clarification results in an additional restriction on what is required should the 31 day period be exceeded. Therefore, it does not change any margins to safety, create a new accident, or increase the probability or consequence of an accident.

In accordance with 10CFR 50.91, this change to the Technical Specifications has been evaluated against three criteria to determine if the operation of the facility in accordance with the proposed amendment would:

1. Involve a significant increase in the probability or consequences of an accident previously evaluated; or
2. Create the possibility of a new or different kind of accident from any accident previously evaluated; or
3. Involve a significant reduction in margin of safety.

The proposed changes do not involve a significant increase in the probability or consequences of an accident previously evaluated because the mini-purge releases will be monitored and isolated by similar monitors and equipment as that which monitored and isolated the old 48 inch purge system.

The proposed changes do not create the possibility of a new or different kind of accident from any previously evaluated because normal effluent and accident releases have been previously evaluated. The proposed changes require operation within the limits previously established.

The proposed changes do not involve a significant reduction in the margin of safety because existing release limitations will continue to be applicable to the mini-purge system and isolation of the mini-purge system will occur through existing protective



features applicable for accident mitigation to containment isolation. In addition, other automatic isolation features are provided to assure added protective margin.

Therefore, Rochester Gas and Electric submits that the issues associated with this amendment request are outside the criteria of 10 CFR 50.91 and a no significant hazards finding is warranted.

Table 1

Detailed Technical Specification Changes

<u>Location</u>	<u>Description of Change</u>	<u>Reason for Change</u>
pp 3.5-2	expanded onto pages 3.5-2 and 3.5-2a	retyping
pp 3.5-2a	added clarification should the 31 day period be exceeded.	specify action after the 31 day period.
pp 3.5-4	expanded onto pages 3.5-4 through 3.5-4b.	retyping
pp 3.5-4a	added basis for mini-purge alignment requirements and requirement for recirculation fan operation.	ensure proper monitoring for mini-purge operation.
pp 3.5-20 item 2	add mini-purge alignment requirements under Plant Ventilation.	ensure proper monitoring for mini-purge operation.
pp 3.5-20 item 3	change "Containment Purge" to "Shutdown Purge".	clarify shutdown purge requirements.
pp 3.5-20 footnote +	footnote + modified	clarify requirements for shutdown purge.
pp 3.5-20 footnote ++	added new footnote ++	specifies alignment of monitors for mini-purge operation.
pp 3.5-21 Action 2,3 and 4	removed "for up to 31 days"	consistency with pp 3.5-2 change
pp 3.5-22 Action 5	removed "for up to 31 days"	consistency with pp 3.5-2 change
pp 3.5-22 Action 5	changed "I" to "E"	typo
pp. 3.5-22	added new action	clarify actions for mini-purge and shutdown purge.
pp. 4.12-2, 4.12.2.1.a	change "containment" to "shutdown" and added "mini-purge"	make specification applicable to shutdown purge and mini-purge

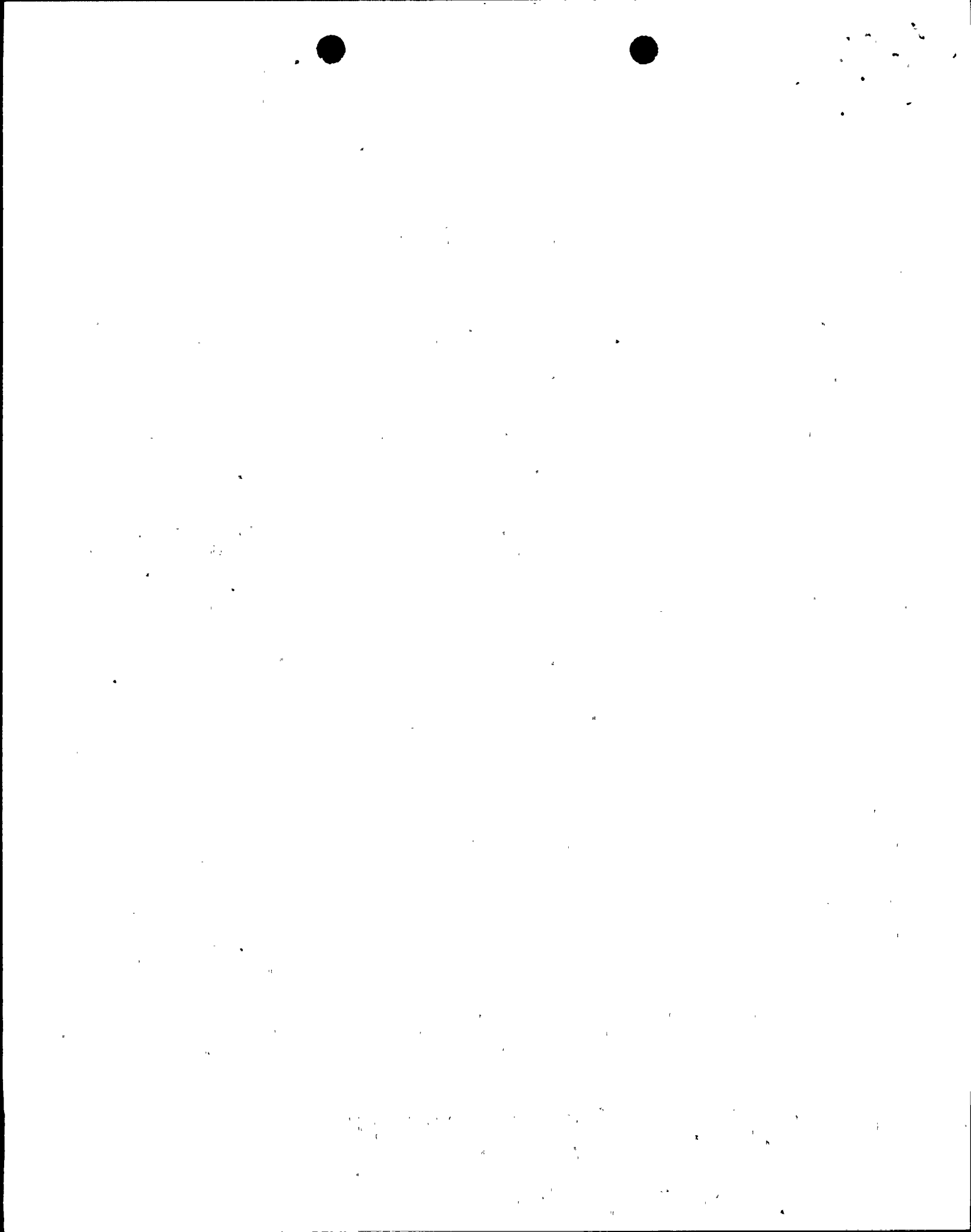
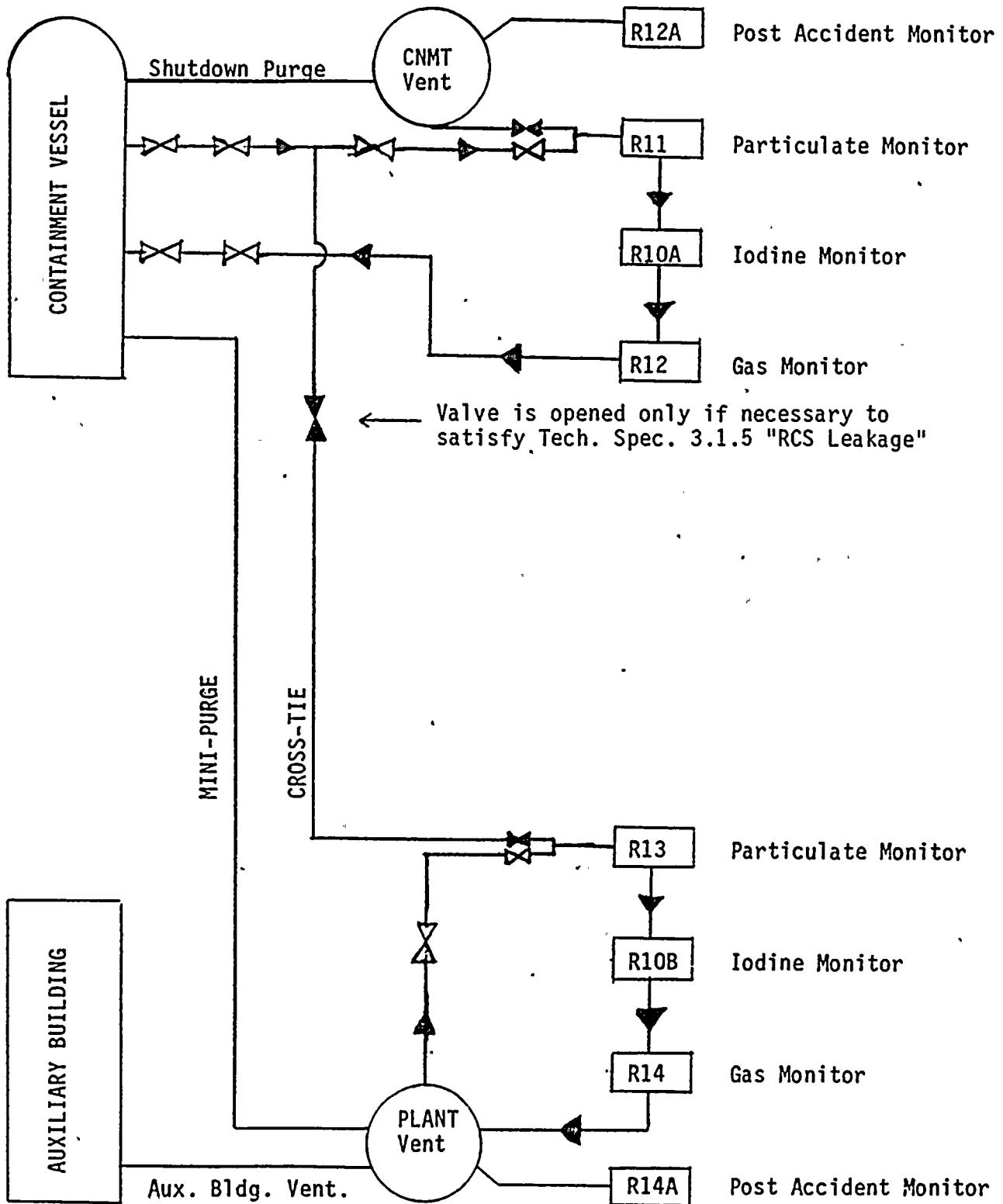

FIGURE 1

RADIATION MONITOR FUNCTIONAL DIAGRAM



NOT AS-BUILT  
FOR ILLUSTRATION PURPOSES ONLY