

## REVISED RESPONSE TO REQUEST FOR ADDITIONAL INFORMATION

### APR1400 Design Certification

Korea Electric Power Corporation / Korea Hydro & Nuclear Power Co., LTD

Docket No. 52-046

RAI No.: 470-8552  
SRP Section: 16 – Technical Specifications  
Application Section: 16.3.3.1  
Date of RAI Issue: 04/26/2016

---

### **Question No. 16-137**

The response to RAI-Question 16-89 was lacking sufficient detail to resolve the questions asked.

1. The applicant is requested to submit a table that shows the following for each component, segment, and portion of the instrument loop from the process sensor through bistable logic, coincidence logic, initiation logic, actuation logic, the component interface module, or reactor trip logic to the reactor trip circuit breakers, or the actuated end device in the ESFAS circuits:

- component name or description
- name of test as depicted on DCD Figure 7.2-11
- name of test as stated in DCD 7.2.2.5
- corresponding generic TS Section 3.3 surveillance requirement as defined in generic TS Section 1.1 (CHANNEL CHECK; CHANNEL FUNCTIONAL TEST, CHANNEL CALIBRATION)

The NRC staff included a draft of the requested table in the agenda notes for the meeting between the NRC staff and Applicant staff on February 24 and 25, 2016. That table was based on information in the DCD and in the response to RAI-Question 16-89. The applicant may use that draft table as a guide in preparing the requested table; however, the staff does not consider the table to be fully accurate because the DCD descriptions are unclear.

2. Notice that DCD Figure 7.2-11 does not depict "CPCS Test" and "Manual Trip Test", which are described in DCD Section 7.2.2.5. The applicant is requested to revise DCD Tier 2 Section 7.2 so that Section 7.2.2.5 and Figure 7.2-11 are correctly aligned. In addition, consider adding a discussion in DCD Tier 2 Section 7.3 that describes the testing for the ESFAS instrumentation loops with the same level of detail as the requested revised description in DCD Tier 2 Section 7.2.2.5, and also a figure equivalent to Figure 7.2-11. Notice that Figure 7.2-11 depicts no tests for ESFAS related components after the input to the actuation logic in the group controller.

3. The last two sentences of the response to RAI-Question 16-89 said,

... the "Bistable Logic Test" and the "CPCS Test" of the RPS CHANNEL FUNCTIONAL TEST are performed in accordance with the Setpoint Control program (SCP). The remaining tests specified in the SCP such as Nominal Trip Setpoint, Allowable Value, As-Found Tolerance, and As-Left Tolerance are not directly related to setpoints.

The applicant is requested to explain what is meant by these statements. For example, the NTSP, AV, AFT, and ALT are not tests. Also, the ESFAS CHANNEL FUNCTIONAL TEST and the CHANNEL CALIBRATION are not mentioned.

4. The applicant is requested to explain what meaning the "OR" logical gate symbols on Figure 7.2-11 are intended to convey; especially with respect to depicting testing overlap. The requested information is needed to enable the NRC staff to determine whether or not surveillances for RPS and ESFAS instrumentation functions satisfy 10 CFR 50.36 requirements.

### **Response – (Rev. 1)**

1. Table 1 is prepared based on DCD Tier 2 Figure 7.2-11, which shows the testing overlap for the periodic manual tests required to verify the integrity of the RPS functions during power operation of the plant. The component names and descriptions in the figure are identified by relationship with the testing type provided in DCD Tier 2 Section 7.2.2.5, "System Testing and Inoperable Surveillance". Additionally, the "CPCS" and "CPCS test" will be included in DCD Tier 2 Figure 7.2-11.

Table 2 is prepared based on a new figure, DCD Tier 2 Figure 7.3-24, "ESF-CCS Actuation Test Logic Diagram". The component names and descriptions in the figure are identified by relationship with the testing type provided in DCD Tier 2 Section 7.3.2.5, "System Testing and Inoperable Surveillance".

DCD Tier 2 Figure 7.3-24 will be added and Section 7.3.2.5 will include items i) and j) for the component logic test and communication interface module (CIM) test.

Table 1. Components List and Corresponding Test between Figure 7.2-11 and Section 7.2.2.5

Components (As depicted in DCD Tier 2 Figure 7.2-11)	DCD Tier 2 Figure 7.2-11, "RPS Testing Overlap"	DCD Tier 2 Section 7.2.2.5	Generic TS Surveillance * performed at power ** 18 month Frequency
Process Sensor	Manual Transmitter Test	a. Sensor check	CHANNEL CHECK **CHANNEL CALIBRATION
CPCS	CPCS Test	c. CPCS test	CPC SYSTEM EVENT LOG CHECK *CHANNEL FUNCTIONAL TEST **CHANNEL CALIBRATION
Termination Unit(TU)	Analog Input Test	a. Sensor check	CHANNEL CHECK **CHANNEL CALIBRATION(MANUAL TRANSMITTER TEST)
BP Rack AI Module A/D [Converter]	Analog Input Test	a. Sensor check	CHANNEL CHECK **CHANNEL CALIBRATION(MANUAL TRANSMITTER TEST)
Bistable Processor (BP) – partial trip signal	Bistable Logic Test	b. Bistable logic test	*CHANNEL FUNCTIONAL TEST
SDL Communication to Local Coincidence Logic (LCL) Rack	Bistable Logic Test	b. Bistable logic test	*CHANNEL FUNCTIONAL TEST
LCL Rack - SDL Signal Distribution (Communication)	Bistable Logic Test	b. Bistable logic test	*CHANNEL FUNCTIONAL TEST
Local Coincidence Logic (LCL) RPS 2/4 → RPS (coincidence) Initiation Signal	RT LCL Logic Test	d. LCL test	*CHANNEL FUNCTIONAL TEST
RPS Digital Output	RT LCL Logic Test RT Initiation Test	d. LCL test e. Initiation logic and circuit test	*CHANNEL FUNCTIONAL TEST
Hardwire to RT Initiation Logic (selective 2/4)	RT LCL Logic Test RT Initiation Test	e. Initiation logic and circuit test	*CHANNEL FUNCTIONAL TEST
Interposing Relay & Contacts	RT Initiation Test	e. Initiation logic and circuit test	*CHANNEL FUNCTIONAL TEST
RTSS-1 and RTSS-2	RT Initiation Test	e. Initiation logic and circuit test	*CHANNEL FUNCTIONAL TEST
RTCB Undervoltage Trip Device	RT Initiation Test	e. Initiation logic and circuit test	*CHANNEL FUNCTIONAL TEST
LCL Rack –SDL Signal Distribution	Bistable Logic Test	<a href="#">Section 7.3.2.5</a> b) Bistable logic test	*CHANNEL FUNCTIONAL TEST
Local Coincidence Logic (LCL) ESFAS 2/4 → ESFAS (coincidence) Initiation Signal	ESF LCL Logic Test	<a href="#">Section 7.3.2.5</a> e) LCL test	*CHANNEL FUNCTIONAL TEST
SDL to Group Controller (GC) Station (ESF-GCS)	ESF LCL Logic Test	<a href="#">Section 7.3.2.5</a> d) Initiation logic test	*CHANNEL FUNCTIONAL TEST

Table 2. Components List and Corresponding Test between Figure 7.3-24 and Section 7.3.2.5

Components (As depicted in DCD Tier 2 Figure 7.3-24)	DCD Tier 2 Figure 7.3-24, "ESF-CCS Actuation Test Logic Diagram"	DCD Tier 2 Section 7.3.2.5	Generic TS Surveillance * performed at power ** 18 month Frequency
Process Sensor	Manual Transmitter Test	a. Sensor check	CHANNEL CHECK **CHANNEL CALIBRATION
Termination Unit(TU)	Analog Input Test	a. Sensor check	CHANNEL CHECK **CHANNEL CALIBRATION(MANUAL TRANSMITTER TEST)
BP Rack AI Module A/D [Converter]	Analog Input Test	a. Sensor check	CHANNEL CHECK **CHANNEL CALIBRATION(MANUAL TRANSMITTER TEST)
Bistable Processor (BP) – partial trip signal	Bistable Logic Test	b. Bistable logic test	*CHANNEL FUNCTIONAL TEST
SDL Communication to Local Coincidence Logic (LCL) Rack	Bistable Logic Test	b. Bistable logic test	*CHANNEL FUNCTIONAL TEST
LCL Rack - SDL Signal Distribution	Bistable Logic Test	<a href="#">Section 7.3.2.5</a> b) Bistable logic test	*CHANNEL FUNCTIONAL TEST
Local Coincidence Logic (LCL) ESFAS 2/4 → ESFAS (coincidence) Initiation Signal	ESF LCL Logic Test	<a href="#">Section 7.3.2.5</a> c) LCL test	*CHANNEL FUNCTIONAL TEST
SDL to Group Controller (GC) Station (ESF-CCS)	ESF LCL Logic Test	<a href="#">Section 7.3.2.5</a> d) Initiation logic test	*CHANNEL FUNCTIONAL TEST
GC Station – Selective 2/4 Logic	Actuation Logic Test	e) Actuation logic test	*CHANNEL FUNCTIONAL TEST
SDL to Loop Controller (Component Control Logic)	Selective Group Test	f) Selective Group Test	*CHANNEL FUNCTIONAL TEST
Component Interface Module (CIM)	CIM Test	j) CIM test	*CHANNEL FUNCTIONAL TEST

2. The missing information of CPCS and CPCS Test in DCD Tier 2 Figure 7.2-11 will be added.

Section 7.2.2.5 of DCD Tier 2 states, "The manual trip test is performed by using one of the two pairs of manual trip pushbuttons on the safety console or one pair of manual trip pushbuttons on the RSC, observing an RTSG trip, and closing the RTSG prior to the next manual trip test." The manual trip test input is directly connected to the reactor trip switchgear system (RTSS) without going through any portion of the plant protection system (PPS) application program containing the bistable processing logic and local coincidence processing logic.

Figure 7.2-16 "Manual Reactor Trip Initiation Diagram" shows that the manual reactor trip input either from the main control room (MCR) or remote shutdown room (RSR) is directly transmitted to the RTSS. The following will be added in item f) of DCD Tier 2 Section 7.2.2.5: "Figure 7.2-16 shows the signal path for the manual trip test."

Figure 7.3-22, "ESF-CCS Simplified Test Logic Diagram" shows the actuation logic test of the group controller (GC) portion of the engineered safety features – component control system (ESF-CCS).

Also, Figure 7.3-24, "ESF-CCS Actuation Test Logic Diagram" will be added to DCD Tier 2 to show the tests that cannot be performed by the PPS. Accordingly, items i) and j) will be added to Section 7.3.2.5 for the component logic test and CIM test.

3. Except for DNBR and LPD trip setpoints, which are programmed in the CPCS to perform the RPS function, all trip setpoints for the RPS and ESFAS functions are set into the PPS bistable logics. For the RPS CHANNEL FUNCTIONAL TEST, the "Bistable Logic Test" and the "CPCS Test" are performed to verify RPS trip setpoints to be within the corresponding Allowable Values. In addition, for the ESFAS CHANNEL FUNCTIONAL TEST, the "Bistable Logic Test" is performed to verify ESFAS trip setpoints to be within the corresponding Allowable Values. The NTSP, AV, AFT, and ALT stated in the Setpoint Control program (SCP) are used for performing the CHANNEL FUNCTIONAL TEST and CHANNEL CALIBRATION for RPS and ESFAS functions. Therefore, it was intended to specify that the "Bistable Logic Test" and the "CPCS Test" are performed in accordance with the SCP since the purpose of the SCP is to establish the requirements for ensuring that setpoint for automatic protective devices are initially within and remain within the assumptions of the applicable safety analyses.
4. The logical OR in the receiving stage of bistable processor (BP) indicates that BP logic is processed either by the actual signal or by the test signal. The logical OR in the receiving stage of LCL indicates that local coincidence logic (LCL) logic is processed either by the actual signal or by the test signal.

The logical OR in the transmitting stage of LCL or the receiving stage of the digital output module indicates that the digital output module generates the output either by the actual signal or by the test signal.

The logical OR symbols on Figures 7.2-11 and 7.3-24 will be explained in DCD Tier 2, In Figure 7.2-11, the logical OR in the receiving stage of bistable processor (BP) indicates that BP logic is processed either by the actual signal or by the test signal. The logical OR in the receiving stage of LCL indicates that local coincidence logic (LCL) logic is processed either by the actual signal or by the test signal. The logical OR in the transmitting stage of LCL or the receiving stage of the digital output module indicates that the digital output module generates the output either by the actual signal or by the test signal.

The prior revisions of the RAI response were incorporated into Rev. 1 of the DCD and TS; therefore this revision starts and only contains mark-ups to Revision 1 of the DCD and TS.

---

### Impact on DCD

DCD Tier 2 Figure 7.2-11 will be revised as indicated in the attachment associated with this response.

DCD Tier 2 Figure 7.3-24 will be added as indicated in the attachment associated with this response.

**Impact on PRA**

There is no impact on the PRA.

**Impact on Technical Specifications**

TS B 3.3.1 will be revised as indicated in the attachment.

**Impact on Technical/Topical/Environmental Reports**

There is no impact on any Technical, Topical or Environmental Report.

Figure 7.2-11

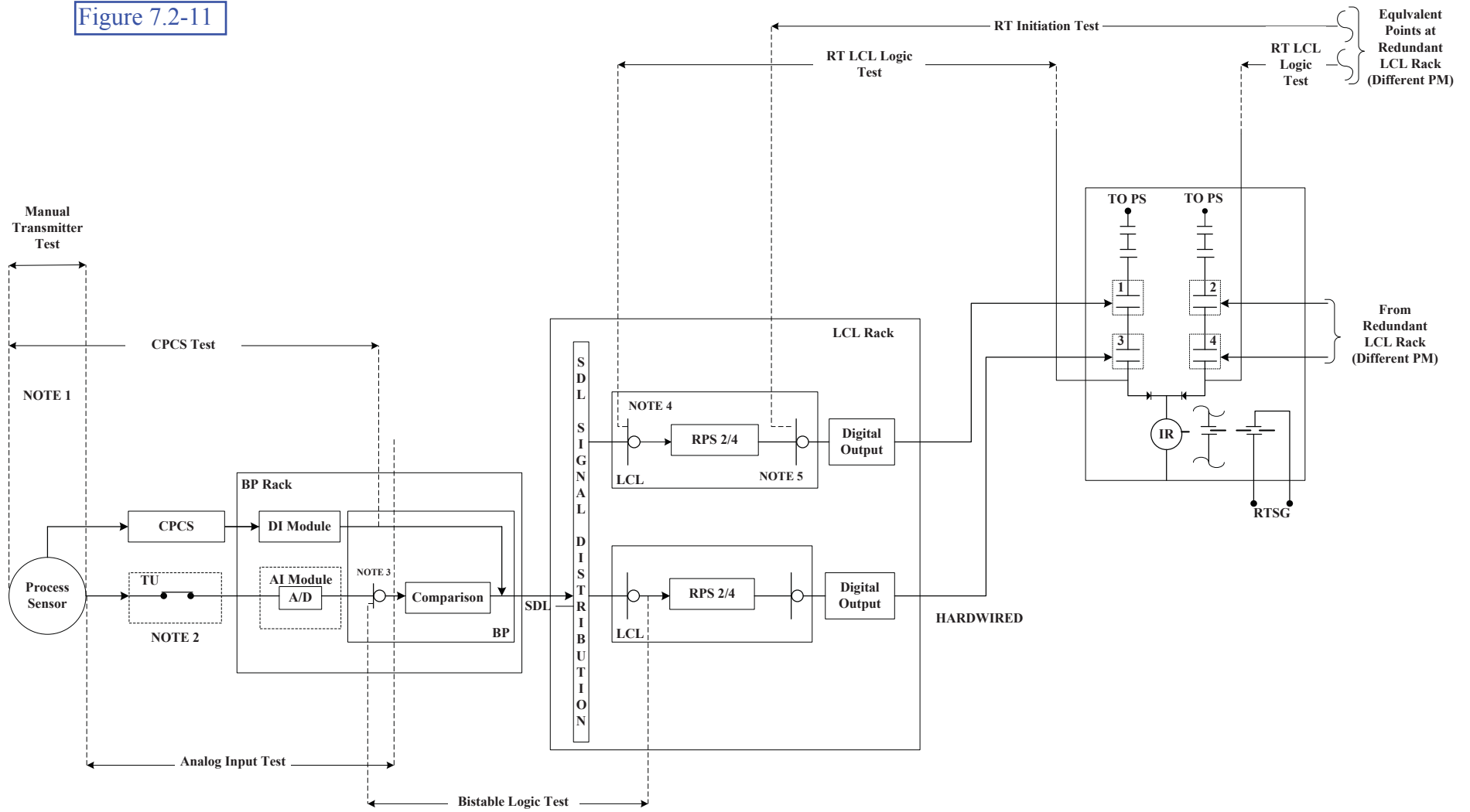

- NOTE:**
1. EACH DASHED LINE INDICATES EITHER THE STARTING OR ENDING POINT OF TESTING.
  2. TERMINATION UNIT (TU) IS A DEVICE WHERE ANALOG AND DIGITAL INPUT SIGNALS ARE BROUGHT INTO. SIMULATED ANALOG INPUT SIGNAL FOR ACCURACY TEST CAN BE CONNECTED TO TU.
  3. SYMBOL "OR" MEANS THE DOWNSTREAM LOGIC IS PROCESSED EITHER BY THE ACTUAL INPUT SIGNAL OR BY THE TEST SIGNAL.

Figure 7.3-24

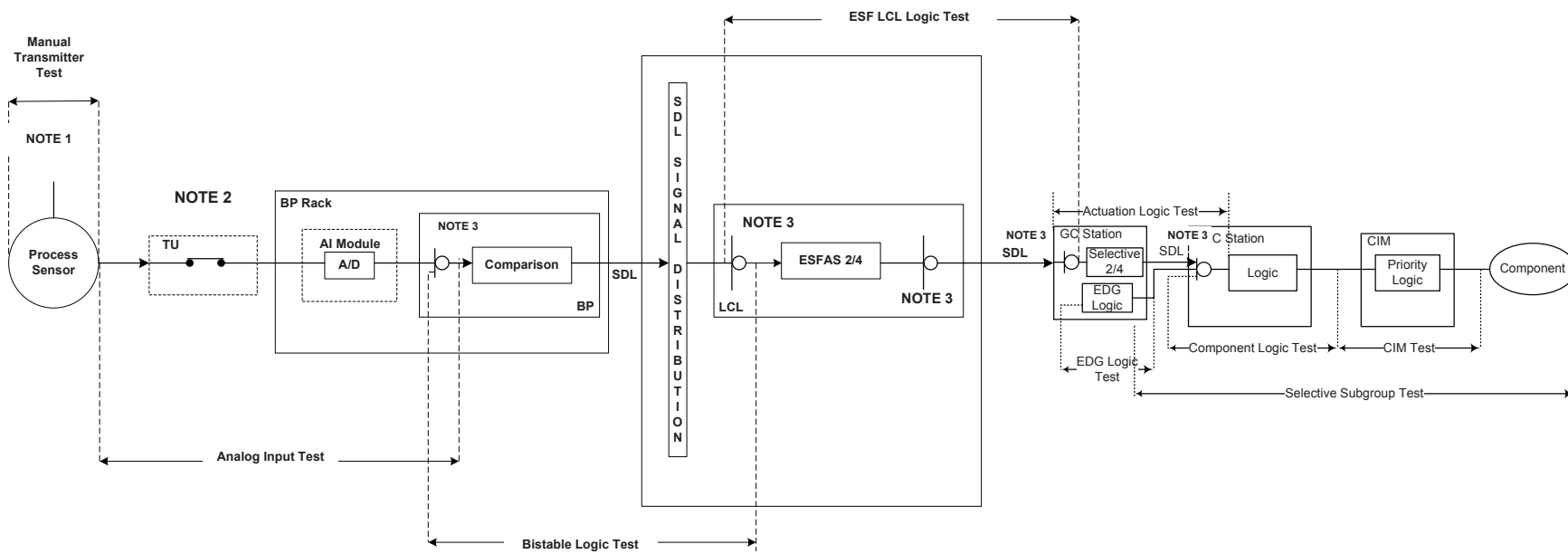

**NOTE:**

1. EACH DASHED LINE INDICATES EITHER THE STARTING OR ENDING POINT OF TESTING.
2. TERMINATION UNIT (TU) IS A DEVICE WHERE ANALOG AND DIGITAL INPUT SIGNALS ARE BROUGHT INTO. SIMULATED ANALOG INPUT SIGNAL FOR ACCURACY TEST CAN BE CONNECTED TO TU.
3. SYMBOL "OR" MEANS THE DOWNSTREAM LOGIC IS PROCESSED EITHER BY THE ACTUAL INPUT SIGNAL OR BY THE TEST SIGNAL.



BASES

BACKGROUND (continued)

The Nominal Trip Setpoint is a predetermined setting for automatic actuation prior to the Analytical Limit and thus exceeded. As such, the NTSP accurately (e.g., calibration), uncertainty (e.g., repeatability), change over time (e.g., drift during surveillance) may influence its actual performance. In this manner, the NTSP is defined such that the NTSP meets the definition of

Technical Specifications compliance problems, as well as reports and corrective actions required by the rule which are not necessary to ensure safety. For example, an automatic protection channel device with a setting that has been found to be different from the NTSP due to some drift of the setting may still be OPERABLE because drift is to be expected. This expected drift would have been specifically accounted for in the setpoint methodology for calculating the NTSP and thus the automatic protective action would still have ensured that the SL would not be exceeded with the "as-found" setting of the protection channel. Therefore, the channel would still be OPERABLE because it would have performed its safety function and the only corrective action required would be to reset the channel within the established as-left tolerance around the NTSP to account for further drift during the next surveillance interval.

Note that, although the channel is OPERABLE under these circumstances, the trip setpoint must be left adjusted to a value within the as-left tolerance, in accordance with uncertainty assumptions stated in the referenced setpoint methodology (as-left criteria), and confirmed to be operating within the statistical allowances of the uncertainty terms assigned (as-found criteria).

However, there is also some point beyond which the channel may not be able to perform its function due to, for example, greater than expected drift. This value needs to be specified in the Technical Specifications in order to define OPERABILITY of the channels and is designated as the Allowable Value.

is within the as-found tolerance band

The NTSPs listed in the SCP are based on the NRC approved setpoint methodology referenced in the SCP, which incorporates all of the known uncertainties applicable for each channel. The magnitudes of these uncertainties are factored into the determination of each NTSP. All field sensors and signal processing equipment for these channels are assumed to operate within the allowances of these uncertainty magnitudes.

Transmitter and signal processing equipment calibration tolerances and drift allowances must be specified in plant calibration procedures, and must be consistent with the values used in the setpoint methodology.

needed. channel fully perform el over ors which ronments). As such,

ABILITY of BLE is forming its RABILITY ement if it of a result in

provided