

REGULATORY INFORMATION DISTRIBUTION SYSTEM (RIDS)

ACCESSION NBR: 81062302121 DOC. DATE: 81/06/19 NOTARIZED: NO DOCKET # 05000335
 FACIL: 50-335 St. Lucie Plant, Unit 1, Florida Power & Light Co.
 AUTH. NAME: UHRIG, R. E. AUTHOR AFFILIATION: Florida Power & Light Co.
 RECIP. NAME: EISENHUT, D. G. RECIPIENT AFFILIATION: Division of Licensing

SUBJECT: Forwards conceptual design description of reactor vessel level monitoring sys developed by CEI owners group which utilizes heated junction thermocouples. Pending final confirmation, util intends to install sys at plant.

DISTRIBUTION CODE: A001S COPIES RECEIVED: LTR 3 ENCL 3 SIZE: 17
 TITLE: General Distribution for after Issuance of Operating License

NOTES:

ACTION:	RECIPIENT	COPIES	RECIPIENT		COPIES		
	ID CODE/NAME		LTR	ENCL		LTR	ENCL
	CLARK, R.	04	13	13			
INTERNAL:	D/DIR, HUM FAC 08	1	1		DIR, DIV OF LIC	1	1
	I&E 06	2	2		NRC PDR 02	1	1
	OELD 11	1	0		OR ASSESS BR 10	1	0
	RAD ASMT BR	1	1		<u>REG. FILE</u> 01	1	1
EXTERNAL:	ACRS 09	16	16		LPDR 03	1	1
	NSIC 05	1	1				

MA
4

JUN 25 1981

TOTAL NUMBER OF COPIES REQUIRED: LTR 40 ENCL 38

5

THE UNIVERSITY OF CHICAGO
 DIVISION OF THE PHYSICAL SCIENCES
 DEPARTMENT OF CHEMISTRY
 5712 S. UNIVERSITY AVENUE
 CHICAGO, ILLINOIS 60637
 TEL: 773-936-3700
 FAX: 773-936-3700
 WWW: WWW.CHEM.UCHICAGO.EDU

RECEIVED
 CHEMISTRY DEPARTMENT
 UNIVERSITY OF CHICAGO
 5712 S. UNIVERSITY AVENUE
 CHICAGO, ILLINOIS 60637
 TEL: 773-936-3700
 FAX: 773-936-3700
 WWW: WWW.CHEM.UCHICAGO.EDU

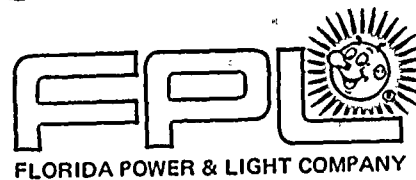

June 19, 1981
L-81-254

Office of Nuclear Reactor Regulation
Attention: Mr. Darrell G. Eisenhut, Director
Division of Licensing
U. S. Regulatory Commission
Washington, D. C. 20555

Dear Mr. Eisenhut:

Re: St. Lucie Unit 1
Docket No. 50-335
Post-TMI Requirements -
Reactor Vessel Level Monitoring System

Our letter L-81-234, dated June 1, 1981 described our schedule for purchasing and installing a Reactor Vessel Level Monitoring System (RVLMS). Recent discussions with the NRC Staff indicate that a more complete design description would be required to allow the finalization of the Staff's review. Please find attached a conceptual design description of the RVLMS developed by the C-E Owners Group which utilizes heated junction thermocouples. Pending final design confirmation and the satisfactory completion of testing, we intend to install this system at St. Lucie Unit 1.

Very truly yours,

Robert E. Uhrig
Vice President
Advanced Systems & Technology

REU/JEM/ras

cc: Mr. J. P. O'Reilly, Region II
Harold F. Reis, Esquire

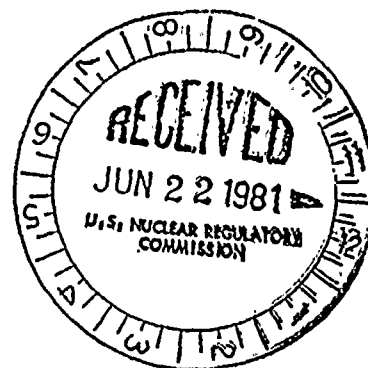

A001
3
3/3

P

8106230212

REACTOR VESSEL LEVEL MONITORING SYSTEM
(RVLMS) SYSTEM CONCEPTUAL DESIGN DESCRIPTION

The conceptual design of the RVLMS is described in the following sections:

1. Sensors Design
2. Signal Processing Design
3. Display Design
4. System Verification Testing
5. System Qualification
6. Operating Instructions

Figure 3-1 is a functional block diagram for the RVLMS. The instrument system consists of two safety grade channels from sensors through signal processing equipment. The outputs of processing equipment systems feeding the primary display are isolated to separate safety grade and non-safety grade systems. Channelized safety grade backup displays are included for each instrument system. The following sections present details of the conceptual design.

1. SENSOR DESIGN

The RVLMS measures reactor coolant liquid inventory with discrete heated junction thermocouple (HJTC) sensors located at different levels within a separator tube ranging from the top of the core to the reactor vessel head. The basic principle of system operation is the detection of a temperature difference between adjacent heated and unheated thermocouples.

As pictured in Figure 3-2, the HJTC sensor consists of a Chromel-Alumel thermocouple near a heater (or heated junction) and another Chromel-Alumel

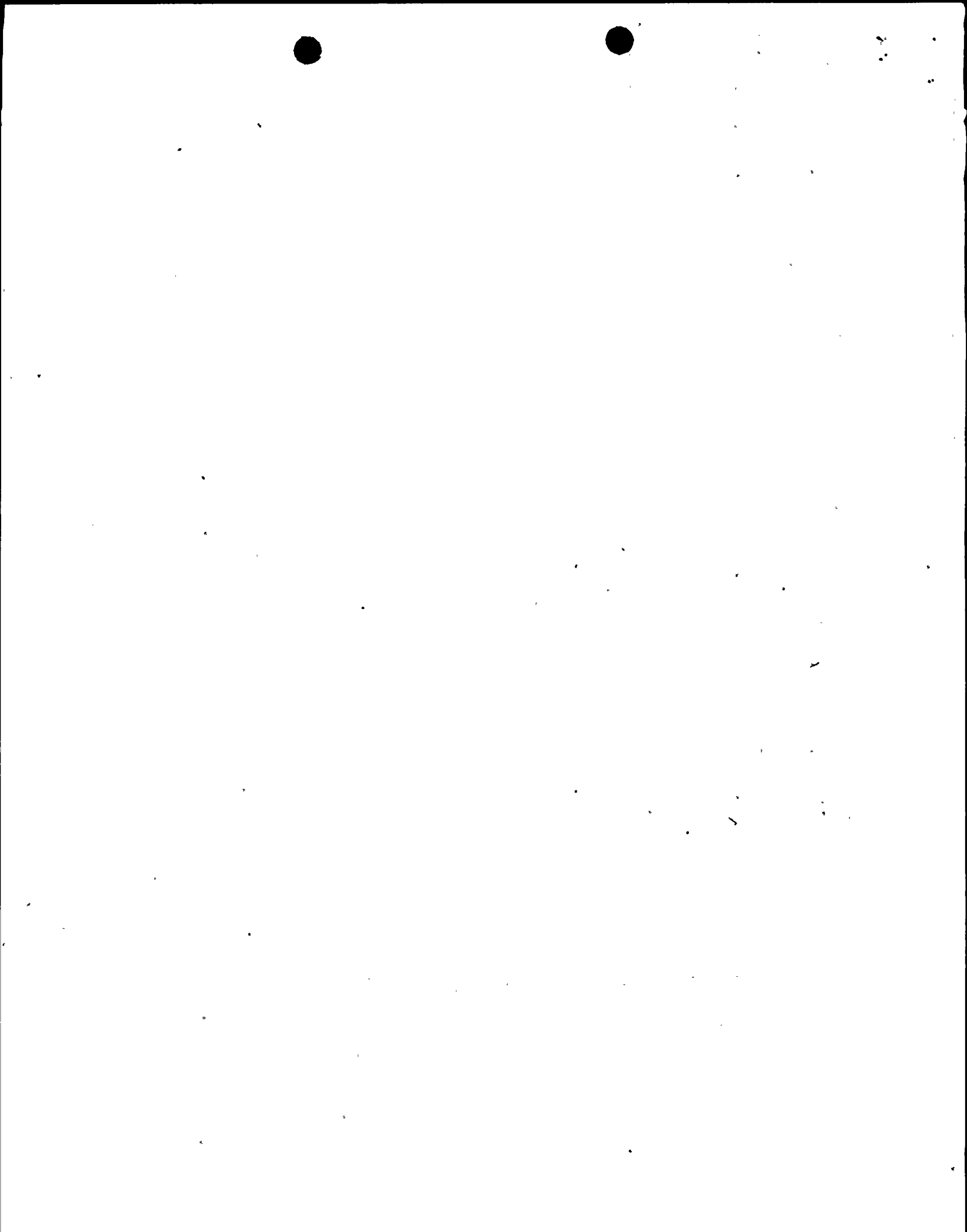

thermocouple positioned away from the heater (or unheated junction). In a fluid with relatively poor heat transfer properties, the temperature difference between the thermocouples is large.

Two design features ensure proper operation under all thermal-hydraulic conditions. First, each HJTC is shielded to avoid overcooling due to direct water contact during two phase fluid conditions. The HJTC with the splash shield is referred to as the HJTC sensor (See Figure 3-2). Second, a string of HJTC sensors is enclosed in a tube that separates the liquid and gas phases that surround it.

The separator tube creates a collapsed liquid level that the HJTC sensors measure. This collapsed liquid level is directly related to the average liquid fraction of the fluid in the reactor head volume above the fuel alignment plate. This mode of direct in-vessel sensing reduces spurious effects due to pressure, fluid properties, and non-homogeneities of the fluid medium. The string of HJTC sensors and the separator tube is referred to as the HJTC instrument.

The HJTC System is composed of two channels of HJTC instruments. Each HJTC instrument is manufactured into a probe assembly. The probe assembly includes eight (8) HJTC sensors, a seal plug, and electrical connectors (Figure 3-3). The eight (8) HJTC sensors are electrically independent and located at eight levels from the reactor vessel head to the fuel alignment plate.

The probe assembly is housed in a stainless steel structure that protects the sensors from flow loads and serves as the guide path for the sensors. Installation arrangements have been developed for each C-E reactor vessel including St. Lucie Unit 1. Installation details will be provided in future documentation.

2. SIGNAL PROCESSING EQUIPMENT DESIGN

The processing equipment of the RVLMS is presently being developed. The processing equipment portion will be composed of a combination of new and existing equipment. The design objective for the equipment is to address the NUREG-0737 criteria, including the criteria of Attachment 1 to II.F.2 and Appendix A. The following description present functional and general hardware design criteria.

The processing hardware will be configured to provide information to the displays described in Section 3. The processing equipment includes operator interfaces for equipment testing, setup, and maintenance. The descriptions are for each of the two separate channels. The outputs of the sensors will be transmitted to the processor, all of which is outside of containment, using qualified cable systems.

The processing for the HJTC instrumentation will have surveillance testing and diagnostic capabilities. Automatic on-line surveillance tests will continuously check for specified hardware and software malfunctions. The on-line automatic surveillance tests as a minimum

will indicate inputs that are out of range and computer hardware malfunctions. The malfunctions will be indicated through the operator interface.

The processing equipment for the RVLMS performs the following functions:

1. Determine if liquid inventory exists at the HJTC positions.

The heated and unheated thermocouples in the HJTC are connected in such a way that absolute and differential temperature signals are available. This is shown in Figure 3-4. When water surrounds the thermocouples, their temperature and voltage output are approximately equal. $V_{(A-C)}$ on Figure 3-4 is, therefore, approximately zero. In the absence of liquid, the thermocouple temperatures and output voltages become unequal, causing $V_{(A-C)}$ to rise. When $V_{(A-C)}$ of the individual HJTC rises above a predetermined setpoint, liquid inventory does not exist at this HJTC position.

2. Determine the maximum upper plenum/head fluid temperature from the unheated thermocouples. (The temperature processing range is from 100°F to 1800°F).
3. Process all inputs and calculated outputs for display.

4. Provide an alarm output when any of the HJTC detects the absence of liquid level.
5. Provide control of heater power for proper HJTC output signal level. Figure 3-5 shows a single channel conceptual design which includes the heater power controller.

3. DISPLAY DESIGN

The RVLMS instrument outputs will be displayed in the control room and technical support center. All displays are designed to be consistent with the criteria in NUREG-0737 Action Item II.F.2, II.F.2 Attachment 1, and Appendix A.

The following information is anticipated to be displayed:

1. Two channels of 8 discrete HJTC positions indicating liquid inventory above the fuel alignment plate.
2. Maximum unheated junction temperature of each of the two channels.
3. Unheated junction temperature at each discrete location.

4. SYSTEM VERIFICATION TESTING

This section describes tests and operational experience with RVLMS instruments.

4.1 HJTC SYSTEM SENSORS

The HJTC System is a new system developed to indicate liquid inventory above the core. Since it is a new system, extensive testing has been performed and further tests are planned to assure that the HJTC System will operate to unambiguously indicate liquid inventory above the core.

The testing is divided into three phases:

Phase 1 -- Proof of Principle Testing

Phase 2 - Design Development Testing

Phase 3 - Prototype Testing

The first phase consisted of a series of five tests, which have been completed. The testing demonstrated the capability of the HJTC instrument design to measure liquid level in simulated reactor vessel thermal-hydraulic conditions (including accident conditions).

TEST 1 Autoclave test to show HJTC (thermocouples only) response to water or steam.

In April 1980, a conceptual test was performed with two thermocouples in one sheath with one thermocouple as a heater and the other thermocouple as the inventory sensor. This configuration was placed in an autoclave (pressure vessel with the capabilities to adjust temperature and pressure). The thermocouples were exposed to water and then steam environments. The results demonstrated a significant output difference between steam and water conditions for a given heater power level.

TEST 2 Two phase flow test to show bare HJTC sensitivity to voids.

In June 1980, a HJTC of the present differential thermocouple design was placed into the Advanced Instrumentation for Reflood Studies (AIRS) test facility, a low pressure two phase flow test facility at Oak Ridge National Laboratory (ORNL). The HJTC was exposed to void fractions at various heater power levels. The results demonstrated that the bare HJTC output was virtually the same in two phase liquid as in subcooled liquid. The HJTC did generate a significant output in 100% quality steam.

TEST 3 Atmospheric air-water test to show the effect of a splash shield.

A splash shield was designed to increase the sensitivity to voids. The splash shield prevents direct contact with the liquid in the two phase fluid. The HJTC output changed at intermediate void fraction two phase fluid. The results demonstrated that the HJTC sensor (heated junction thermocouple with the splash shield) sensed intermediate void fraction fluid conditions.

TEST 4 High pressure boil-off test to show HJTC sensor response to reactor thermal-hydraulic conditions.

In September 1980, a C-E HJTC sensor (HJTC with splash shield) was installed and tested at the ORNL Thermal-Hydraulics Test Facility (THTF). The device is still installed and available for further tests at ORNL. The HJTC sensor was subjected to various two phase fluid conditions at reactor temperatures and pressures. The results verified that the HJTC sensor is a device that can sense liquid inventory under normal and accident reactor vessel high pressure and temperature two phase conditions.

TEST 5 Atmospheric air-water test to show the effect of a separator tube

A separator tube was added to the HJTC design to form a collapsed liquid level so that the HJTC sensor directly measures liquid inventory under all simulated two phase conditions. In October, 1980, atmospheric air-water tests were performed with HJTC sensor and the separator tube. The results demonstrated that the separator tube did form a collapsed liquid level and the HJTC output did accurately indicate liquid inventory. This test verified that the HJTC instrument, which includes the HJTC, the splash shield, and the separator tube, is a viable measuring device for liquid inventory.

The Phase 2 test program consisted of high pressure and temperature tests on the HJTC instrument. Testing was recently conducted and in all cases the instrument performed as designed. A full test report is due to be issued in July of 1981.

The Phase 3 test program will consist of high temperature and pressure testing of the manufactured prototype system HJTC probe assembly and processing electronics. Verification of the HJTC system prototype will be the goal of this test program. The Phase 3 test program is expected to be completed by the end of 1981.

4.2 PROCESSING AND DISPLAYS

The final processing and display design for the RVLMS has not been completed. As the design effort proceeds, design evaluations will be performed prior to installation. Correct implementation of the software and hardware will be included and documented as part of the design effort.

5. SYSTEM QUALIFICATION

The qualification program for the RVLMS instrumentation has not been completely defined. However, plans are being developed based on the following three categories of RVLMS instrumentation:

1. Sensor instrumentation within the pressure vessel.
2. Instrumentation components and systems which extend from the primary pressure boundary up to and including the primary display isolator and including the backup displays.
3. Instrumentation systems which comprise the primary display equipment.

A preliminary outline of a qualification program for each classification is given below.

The in-vessel sensors will meet the NUREG-0737, Appendix A guide to install the best equipment available consistent with qualification and schedular requirements. Design of the equipment will be consistent with the guidelines of Appendix A as well as the clarification and Attachment 1 to Item II.F.2 in NUREG-0737. Specifically, instrumentation will be designed such that they meet appropriate stress criteria when subjected to normal and design basis accident loadings. Verification testing will be conducted to confirm operation at LOCA (as defined by C-E) pressure and temperature conditions. Seismic testing to safe shutdown conditions will verify function after being subjected to the seismic loadings.

The out-of-vessel instrumentation system, up to and including the TSC display isolator, and the control room displays will be environmentally qualified in accordance with IEE-323-1974.

Plant-specific containment temperature and pressure design profiles will be utilized where appropriate in these tests. This equipment will also be seismically qualified.

6. OPERATING INSTRUCTIONS

Guidelines for reactor operators to use the RVLMS and take corrective action have been developed by the C-E Owners Group and submitted to NRC for review via letter dated December 10, 1980 from the C-E Owner's Group "C-E Generic Emergency Procedure Guidelines". These guidelines have been used to review and revise the plant emergency procedures for St. Lucie Unit 1.

The C-E Owners Group is defining a program for development of further emergency procedure guidelines and operator training materials associated with the RVLMS described. This program is expected to provide these guidelines and training materials during 1981. A more specific schedule is subject to finalization of the RVLMS design, specifically the instrument displays.



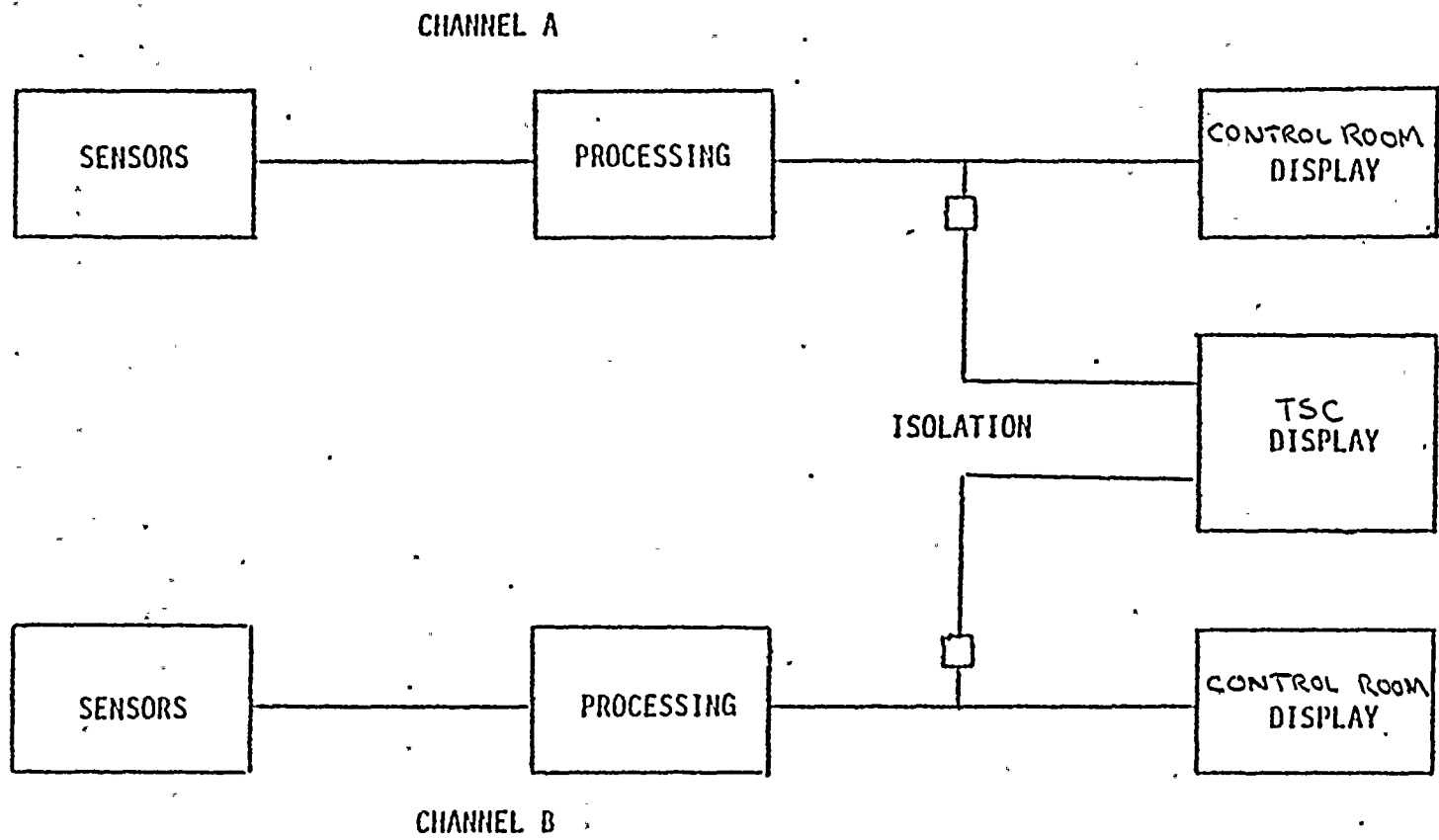

FIGURE 3-1
INSTRUMENTS FUNCTIONAL BLOCK DIAGRAM

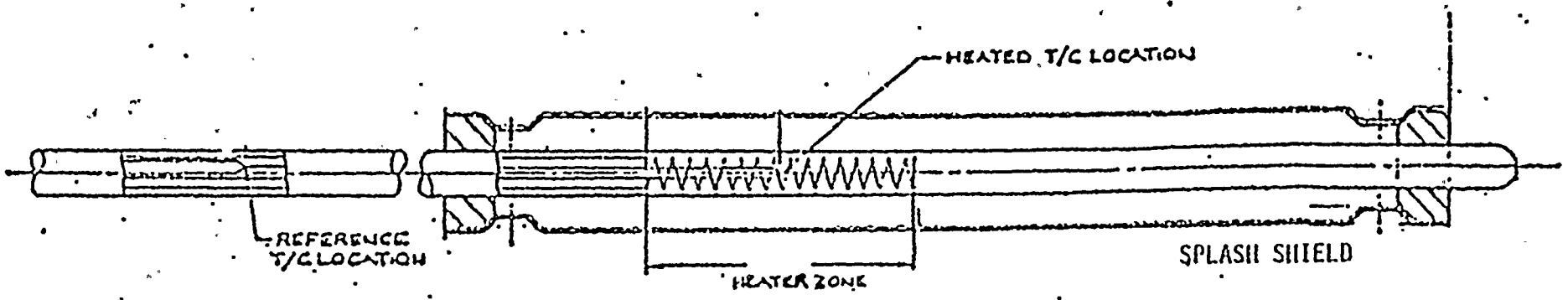

FIGURE 3-2
HJTC SENSOR - HJTC/SPLASH SHIELD

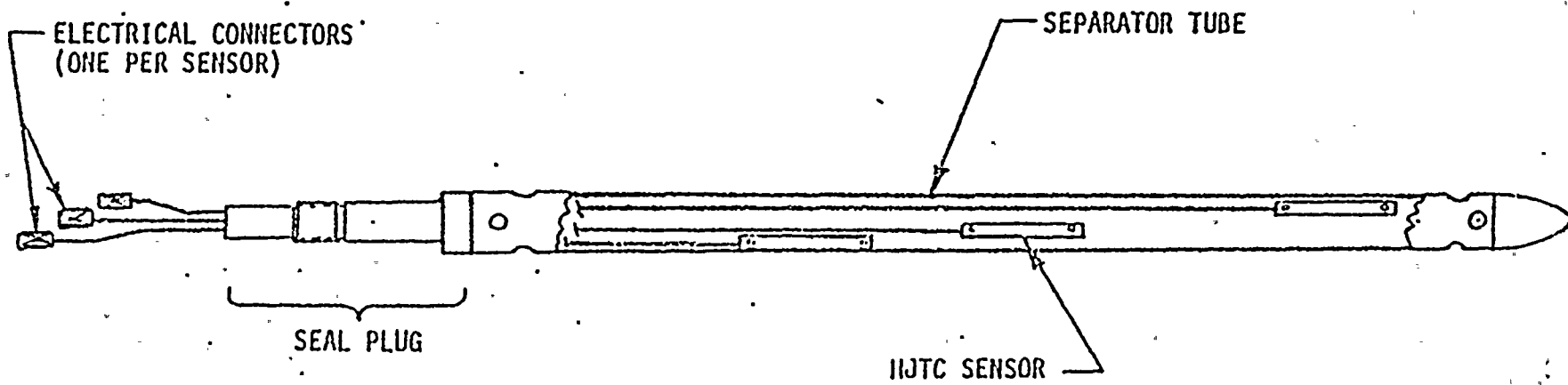
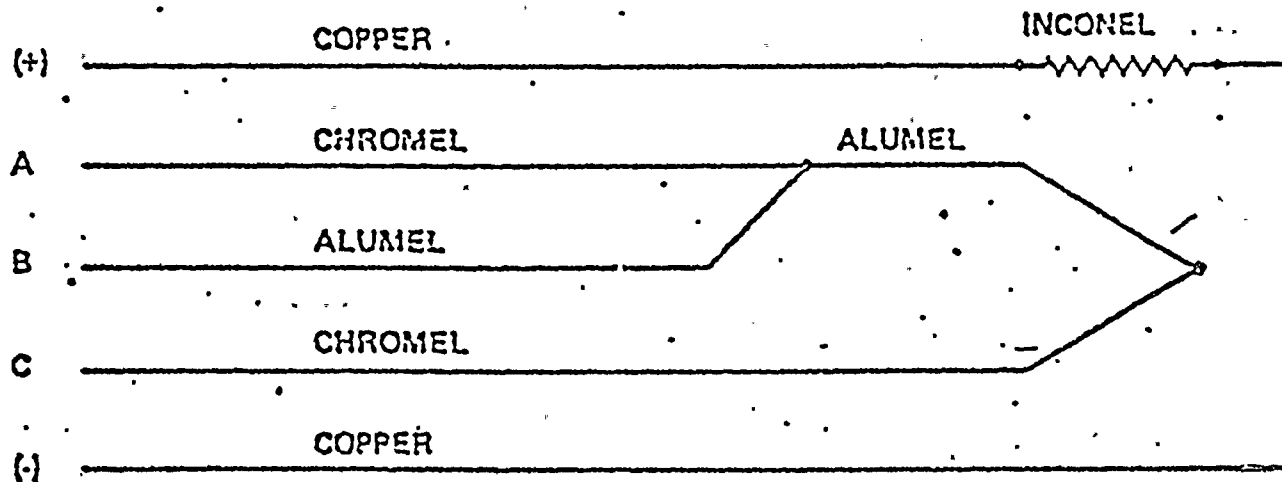
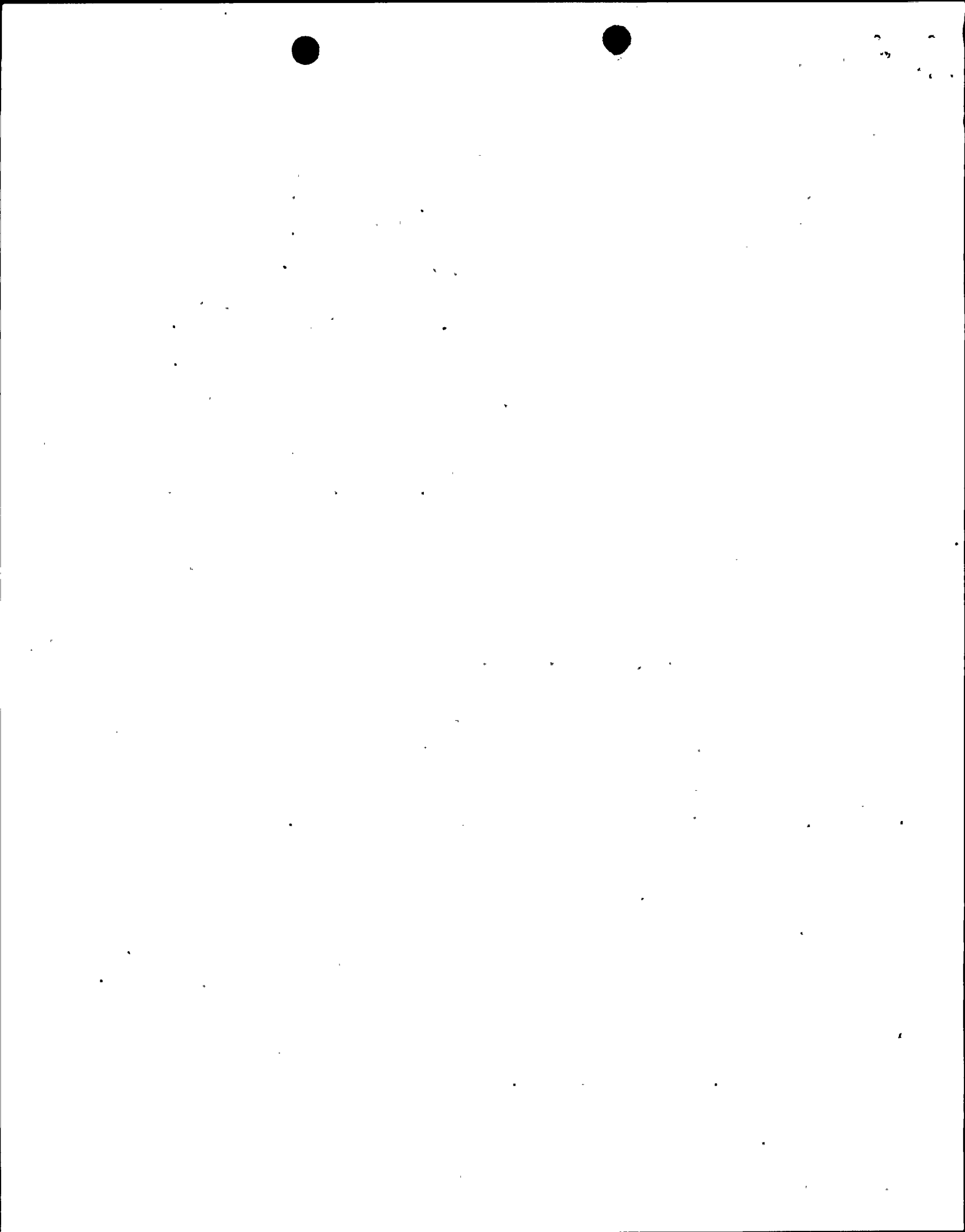

FIGURE 3-3
HEATED JUNCTION THERMOCOUPLE
PROBE ASSEMBLY



$V(A-B)$ = ACTUAL TEMPERATURE, UNHEATED JUNCTION
 $V(C-B)$ = ACTUAL TEMPERATURE, HEATED JUNCTION
 $V(A-C)$ = DIFFERENTIAL TEMPERATURE

FIGURE 3-4
 ELECTRICAL DIAGRAM OF H. J. T. C.



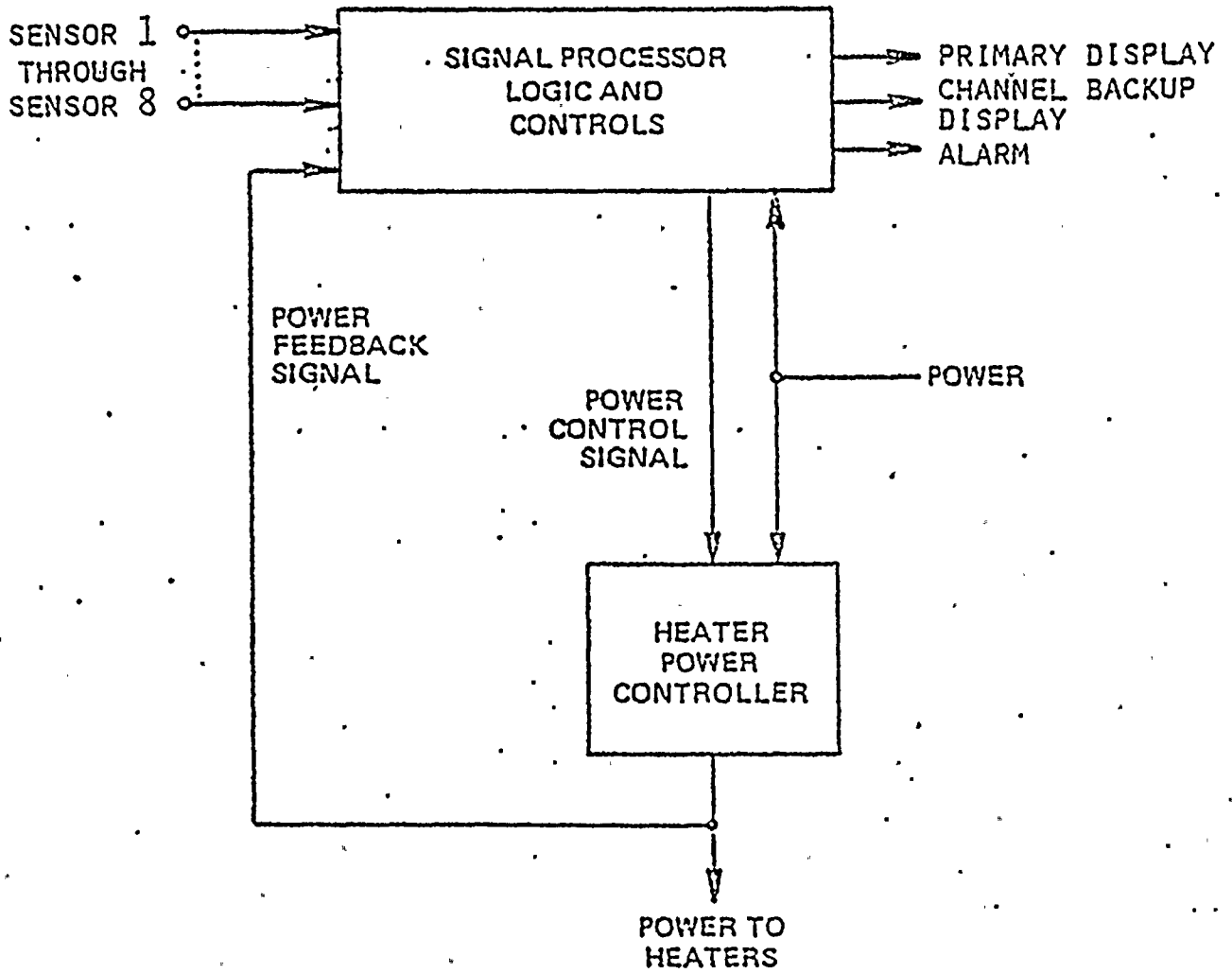

FIGURE 3-5

HJTC SYSTEM PROCESSING CONFIGURATION
(ONE CHANNEL SHOWN)