

ISHAM, LINCOLN & BEALE
COUNSELORS AT LAW

ONE FIRST NATIONAL PLAZA FORTY-SECOND FLOOR
CHICAGO, ILLINOIS 60603
TELEPHONE 312-558-7500 TELEX: 2-5288

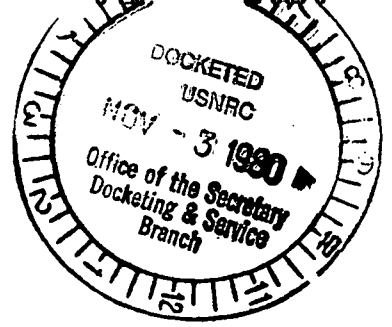

WASHINGTON OFFICE
1120 CONNECTICUT AVENUE, N.W.
SUITE 325
WASHINGTON, D. C. 20036
202-833-9730

October 29, 1980

UNITED STATES OF AMERICA
NUCLEAR REGULATORY COMMISSION

THE ATOMIC SAFETY AND LICENSING BOARD

In the Matter of)
) Docket Nos. 50-237-SP
COMMONWEALTH EDISON COMPANY) 50-249-SP ✓
) (Spent Fuel Pool
(Dresden Station, Units 2 & 3) Modification)

Dear Board Members:

Enclosed are a number of revised pages (Revision 3) to the Licensing Report dated February 3, 1978 which forms a portion of Commonwealth Edison's application in this case. This revision brings the Licensing Report up to date and in addition corrects a number of mistakes. The most important of these corrections is that the number of storage spaces to be installed has been reduced from 7560 to 7074. The reason for this change is that due to a failure of communication between Commonwealth Edison and its architect-engineer, Quadrex-NSC, the original plan did not leave sufficient space in the pool for fuel preparation equipment or for the refueling canal gate. A second change which I wish to bring to your attention is a small increase in K effective (ΔK_3 shown in Table 3.3-1) to account for an unanticipated cumulative effect relating to rack pitch tolerance encountered during fabrication of the racks.

Applicant will be prepared to discuss these changes at greater length in the evidentiary hearings, at which time we will also offer into evidence a complete, bound version of Revision 3 of the Licensing Report for the convenience of the Board and the parties. The Staff and the State of Illinois have been informed of the substance of the changes incorporated in Revision 3 for some time.

Sincerely,

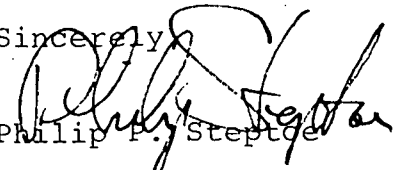
Philip P. Steptoe

PPS/bk
ENC.

CC: Service List

8011050 216

G

DS03

30/1

QUAD-1-79-234

(Previously sent to client under
NSC-COM-0219-R001)

Rev. 3

LICENSING REPORT
DRESDEN NUCLEAR POWER PLANT
UNITS 2 AND 3
SPENT FUEL RACK MODIFICATION

Prepared for:

COMMONWEALTH EDISON COMPANY

October, 1980

3	<i>DP Hines</i>	<i>E. M. P. Smith</i>	<i>J. J. McCoy</i>	<i>J. M. Clark</i>	<i>10-17-80</i>
2	<i>Jeffrey Wang</i>	<i>B. J. West</i>	<i>W. L. Smith</i>	<i>J. M. Clark</i>	<i>10-11-78</i>
1	<i>Jeffrey Wang</i>	<i>B. J. West</i>	<i>W. L. Smith</i>	<i>J. M. Clark</i>	<i>2-6-78</i>
0	<i>R. M. P. Smith</i>	<i>B. J. West</i>	<i>W. L. Smith</i>	<i>J. M. Clark</i>	<i>12-30-77</i>
REV. NO.	ENGINEER	REVIEWER	PROJECT ENGINEER	PROJECT MANAGER	DATE OF APPROVAL



(Previously NSC-COM-0219-R001)

DOCUMENT #: QUAD-1-79-234

REVISION NO. 3

SHEET 1 OF 1

REVISION SHEET

ITEM	DESCRIPTION	PAGE NO.
1.	Section 1.0 - Total storage spaces per pool changed from 3780 to 3537	1-1
2.	Section 3.1 - Fuel storage capability through year 2005 changed to end of first refueling in 2001.	3-1
3.	Table 3.1-1 - Modification in accordance with revised storage capability and fuel discharge schedule.	3-2 3-2
4.	Figure 3.1-2 - Revised figure to reflect retention of fuel prep. area and gate storage area.	3-5
5.	Section 3.2 - Revised number of racks.	3-6
6.	Figure 3.2-1 - Revision of poisoned length from 144 inches to 144 inches minimum and the dimension indicating the location of poison from the bottom of the tube.	3-7
7.	Figure 3.2-2 - Revised overall width of fuel rack and revised elevation of fuel support plate.	3-8
8.	Table 3.3-1 - Revised Δk_3 and k_{eff} .	3-10
9.	Section 3.3.5 - Revised k_{eff} for condition 5.	3-16
10.	Figure 3.3-6 - Revised figure to reflect the correct geometry of the fuel racks.	3-26
11.	Figure 3.3-9 - Revised figure to include k_{eff} at a pitch of 6.2 inches.	3-29
12.	Figure 3.6-8 - Number of flow channels changed from 30 to 28.	3-64
13.	Figure 3.6-9 - Revised fuel storage pool arrangement.	3-65

NUCLEAR SERVICES CORPORATION

COMMONWEALTH EDISON COMPANY
LICENSING REPORT
DRESDEN NUCLEAR POWER PLANT
UNITS 2 AND 3
SPENT FUEL RACK MODIFICATION

1.0 INTRODUCTION

This report covers the design and analysis for a proposed fuel storage rack modification to the Dresden Units 2 and 3 spent fuel storage pools. The proposed modification will increase fuel storage capacity by replacing the present spent fuel storage racks with high density neutron absorbing spent fuel storage racks.

This will increase the storage capacity from 1400 and 1420 spaces for Dresden 2 and 3 pools to 3537 storage spaces for each pool.



NUCLEAR SERVICES CORPORATION

3.0 SUMMARY OF DESIGN MODIFICATION ANALYSES

3.1 General Description

Dresden Nuclear Power Plant consists of two Boiling Water Reactor nuclear generating units. The fuel storage system include a spent fuel storage pool located adjacent to each reactor vessel.

The present capacity of the storage pools is 1400 spent fuel storage spaces for Dresden 2 and 1420 spent fuel storage spaces for Dresden 3, (see Table 3.1-1 and Figure 3.1-1).

The proposed change will increase the capacity to a maximum of 7074 total storage spaces with all racks in place and will extend the fuel storage capability through the first refueling in the year 2001. (See Table 3.1-1 and Figure 3.1-2.)

3

The proposed spent fuel storage rack is composed of a checkerboard arrangement of stainless steel tubes with BORAL neutron absorbing material. The tube is so constructed as to completely encapsulate and seal the absorber material. These tubes are then welded together at the corner along the length of the tube to form the fuel rack module.

BORAL has operated successfully over many years in water environments and has been licensed for Yankee Rowe, Maine Yankee, La Crosse, and other Nuclear power plants.

TABLE 3.1-1
DRESDEN 2 AND 3
FUEL STORAGE EXPANSION
(DRESDEN 2 OR 3 FULL CORE - 724 ASSEMBLIES)



END OF REFUELING	UNIT 2			UNIT 3			UNITS 2 AND 3		
	ELEMENTS	DISCHARGED	SPACES AVAILABLE	ELEMENTS	DISCHARGED	SPACES AVAILABLE	ELEMENTS	DISCHARGED	SPACE AVAILABLE
	ANNUAL	CUMULATIVE		ANNUAL	CUMULATIVE		ANNUAL	CUMULATIVE	
1973	0	0	1400	52	52	1368	52	52	2768
1974	156	156	1244	44	96	1324	200	252	2568
1975	0	156	1244	140	236	1184	140	392	2428
1976	160	316	1084	148	384	1036	308	700	2120
1977	192	508	892	0	384	1036	192	892	1928
1978	0	508	892	176	560	860	176	1068	1752
1979	160	668	732	0	560	860	160	1228	1592
1980	0	668	732	200	760	660	200	1428	1392
1981	224	892	508	0	760	660	224	1652	1168
1982*	0	892	2645	224	984	2553	224	1876	5198
1983	224	1116	2421	208	1192	2345	432	2308	4766
1984	208	1324	2213	0	1192	2345	208	2516	4558

*The proposed change is scheduled to be completed before June of the year 1982.

3-2

TABLE 3.1-1 (Continued)



END OF REFUELING	UNIT 2			UNIT 3			UNITS 2 AND 3		
	ELEMENTS	DISCHARGED	SPACES AVAILABLE (3537)	ELEMENTS	DISCHARGED	SPACES AVAILABLE (3537)	ELEMENTS	DISCHARGED	SPACES AVAILABLE (7074)
	ANNUAL	CUMULATIVE		ANNUAL	CUMULATIVE		ANNUAL	CUMULATIVE	
1985	0	1324	2213	204	1396	2141	204	2720	4354
1986	204	1528	2009	204	1600	1937	408	3128	3946
1987	204	1732	1805	0	1600	1937	204	3332	3742
1988	0	1732	1805	204	1804	1733	204	3536	3538
1989	204	1936	1601	204	2008	1529	408	3944	3130
1990	204	2140	1397	0	2008	1529	204	4148	2926
1991	0	2140	1397	204	2212	1325	204	4352	2722
1992	204	2344	1193	204	2416	1121	408	4760	2314
1993	204	2548	989	0	2416	1121	204	4964	2110
1994	0	2548	989	204	2620	917	204	5168	1906
1995	204	2752	785	204	2824	713	408	5576	1498
1996	204	2956	581	0	2824	713	204	5780	1294
1997	0	2956	581	204	3028	509	204	5984	1090
1998	204	3160	377	204	3232	305	408	6392	682**
1999	204	3364	173	0	3232	305	204	6596	478
2000	0	3364	173	204	3436	101	204	6800	274
2001	204	3568	***	204	3640	***	408	7208	***

3-3

**Full core discharge capability lost in the year 1998.

***Discharge to pool capability lost in the year 2001.

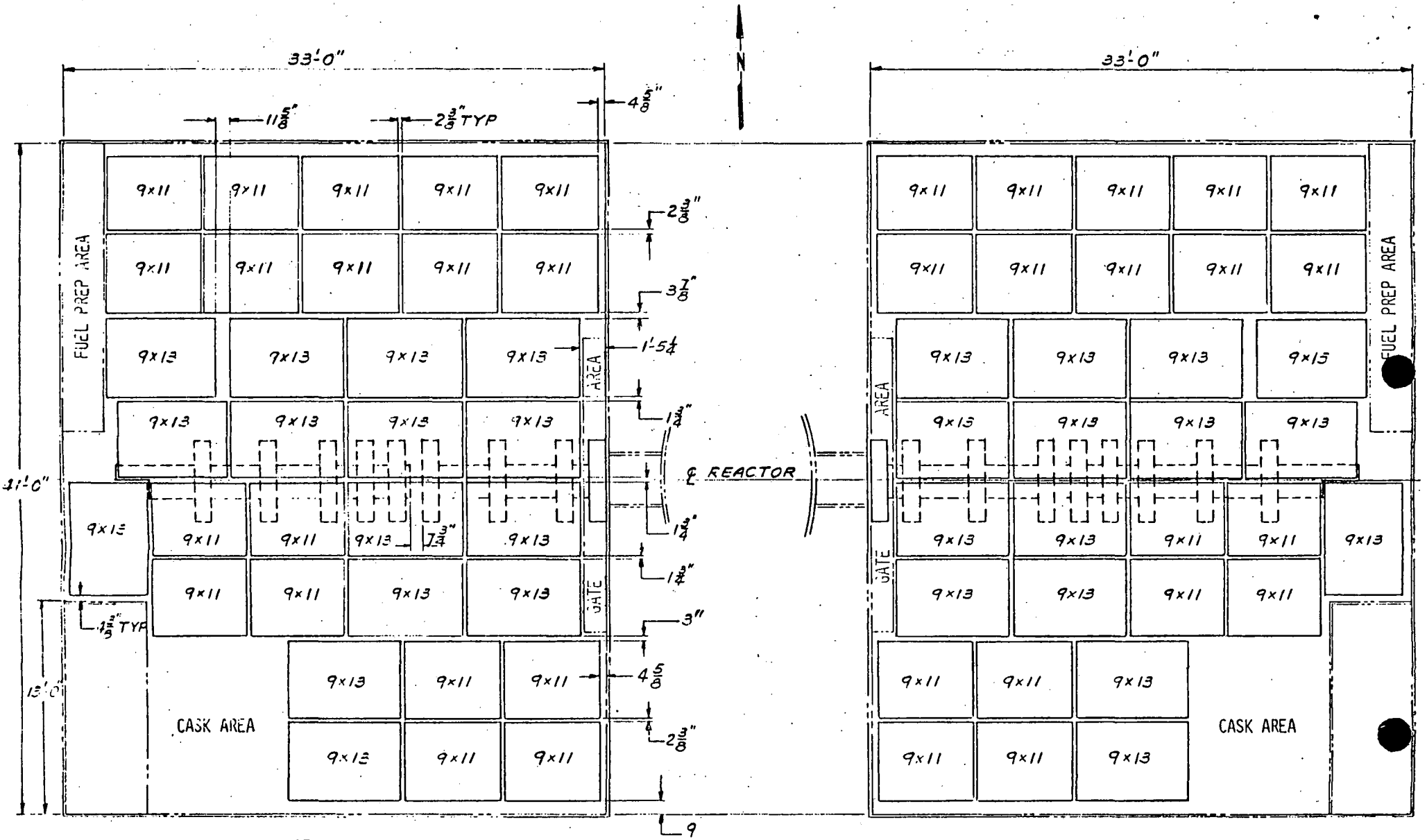

UNIT NO. 3

UNIT NO. 2

DRESDEN UNITS NO. 2 & 3
FUEL STORAGE POOL ARRANGEMENT



3.2 Mechanical Design

Two sizes of racks have been designed to provide the additional storage. One size will store 99 assemblies in a 9 x 11 array. The other unit will store 117 assemblies in a 9 x 13 array. There are 18 racks of 9 x 11 array and 15 racks of 9 x 13 array which makes a total of 3537 spent fuel storage spaces for each generating unit.

The rack is made up of checkerboard array of neutron absorbing tubes that are welded together along the length of the tubes with angles or clips which provide the inter-tube connection. The center to center distance between assemblies is 6.30 inch by 6.30 inch.

The fuel tube is stainless steel bearing BORAL neutron absorbing material produced by Brooks and Perkins. The tube is so constructed as to completely encapsulate and seal the absorber material. See Figure 3.2-1 for details.

The rack consists of a base assembly with legs and with plates along the edges and across the midpoint of the rack. A support plate is provided in each storage position to hold the fuel assembly. The support plate is elevated about 12.5 inches above the pool floor and it is welded to the lower end of the tube. Cooling water flows through holes and/or slots in the sides of the support plates through the storage tubes to cool the stored fuel. Along the side of the rack between tubes, a filler plate assembly is welded between the absorber tube assemblies to enclose the space between tubes. The racks are so designed to prevent application of excessive vertical forces from the fuel handling system. (See Figure 3.2-2 for detail rack configuration).

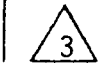

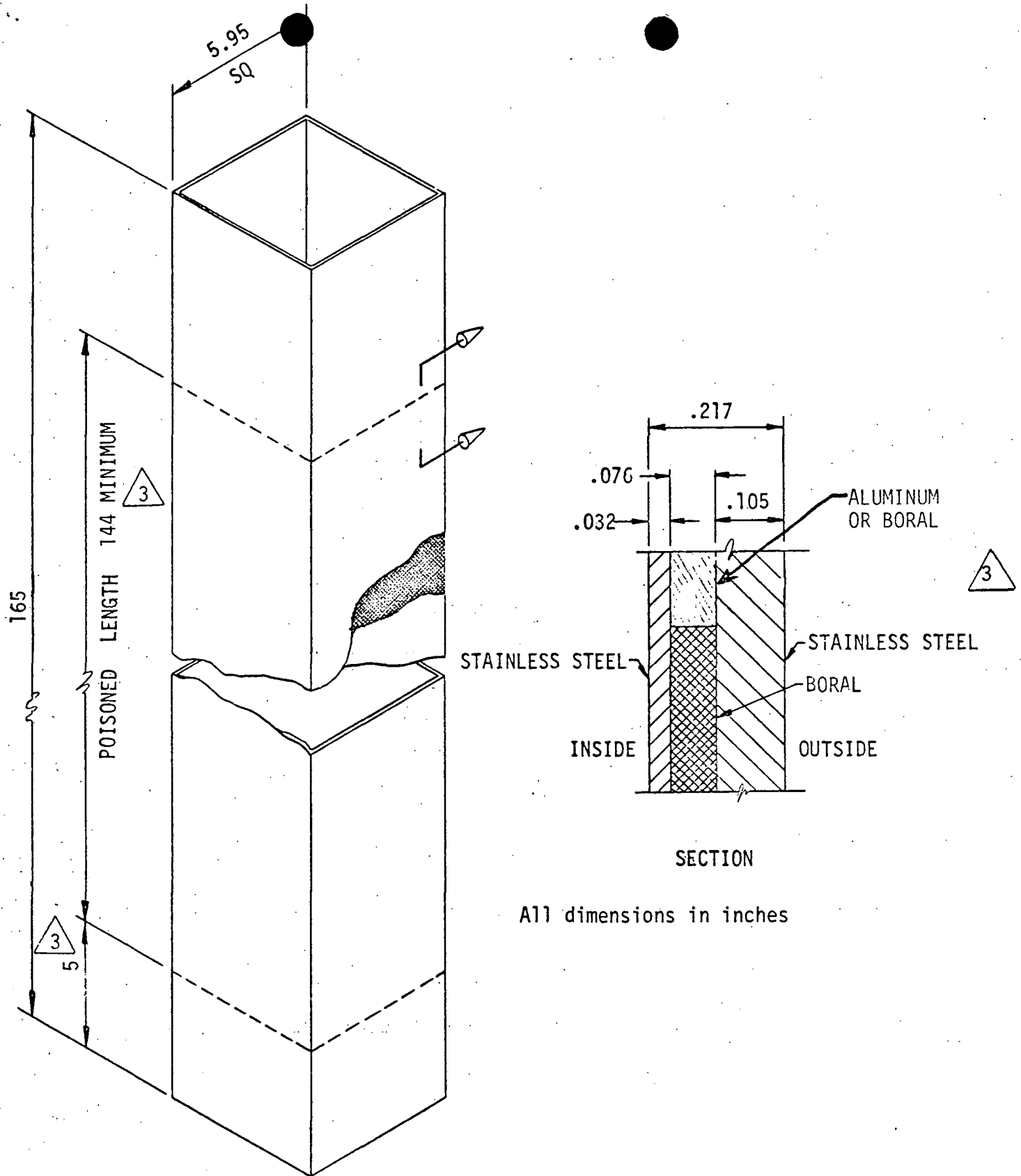

FIGURE 3.2-1. STAINLESS STEEL TUBE
WITH BORAL CORE
FOR DRESDEN FUEL STORAGE

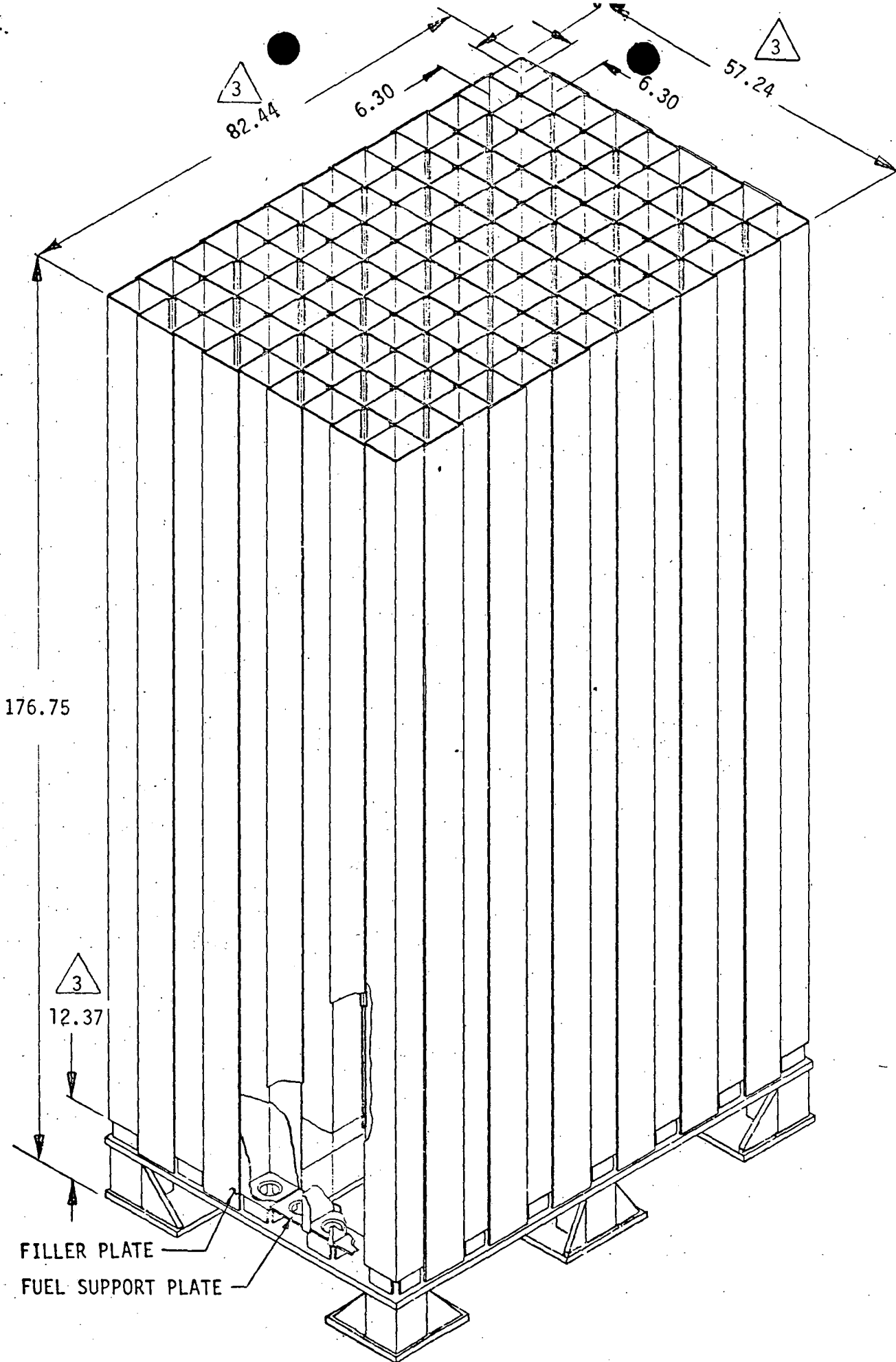

FIGURE 3.2-2. 9 X 13 SPENT FUEL RACK
DRESDEN UNITS 2 AND 3

TABLE 3.3-1
DRESDEN, UNIT 2 AND 3
 k_{eff} RESULTS

<u>TERM</u>	<u>VALUE</u>		<u>METHOD</u>
	<u>7 x 7</u>	<u>8 x 8</u>	
k_0	.90425	.90733	Calculated for cell
Δk_1	.005	.005	Estimated from similar design
Δk_2	<0*	<0*	Calculated from sensitivity analysis
Δk_3	0.00618	0.00618	Calculated using a 6.300" nominal pitch and a -0.060" average change on the pitch due to a manufacturing tolerance.
Δk_4	<0*	<0*	Critical experiment calculations
Δk_5	.0084	.0084	Critical experiments results, 95% confidence level
Δk_6	0	0	Minimum values of boron density and thickness are used for absorber plate
Δk_7	.002	.002	Estimated for 0.02 w/o enrichment increase



$$k_{eff} \leq k_0 + \Delta k_1 + \Delta k_2 + \Delta k_3 + \Delta k_4 + (\Delta k_5^2 + \Delta k_6^2 + \Delta k_7^2)^{1/2}$$

$$\leq 0.92406 \text{ for } 7 \times 7$$

$$\leq 0.92714 \text{ for } 8 \times 8$$



* In the calculation of k_{eff} , these uncertainties are conservatively assumed to be zero.

3.3.5 Results of Calculations

The nominal results of the k_{eff} calculations for normal storage and handling are listed as follows:

<u>CONDITION</u>	k_{eff}	
	<u>7 x 7</u>	<u>8 x 8</u>
1. Normal positioning in the spent fuel storage array See Figure 3.3-1	0.90425	0.90733
2. Eccentric positioning in the spent fuel storage array		
a. fuel inside absorber tube offset diagonally (Fig. 3.3-2)	0.89613	0.89915
b. fuel not inside absorber tube offset diagonally (Fig. 3.3-3 Case 1)	0.90089	0.90395
c. both fuel assemblies offset diagonally (Fig. 3.3-3, Case 2)	0.89309	0.89609
3. Eccentric positioning in the spent fuel storage array with the channel offset 0.1" (2.54 mm) in both X and Y See Figure 3.3-4	0.90408	0.90716
4. One extra fuel assembly at side of rack See Figure 3.3-5	0.90654	0.90964
5. All racks in contact with each other See Figure 3.3-6	0.91157	0.91469



In Conditions 4 and 5, rack size is conservatively assumed to be 7 x 9. This will give greater reactivity than the actual 9 x 11 or 9 x 13 racks.

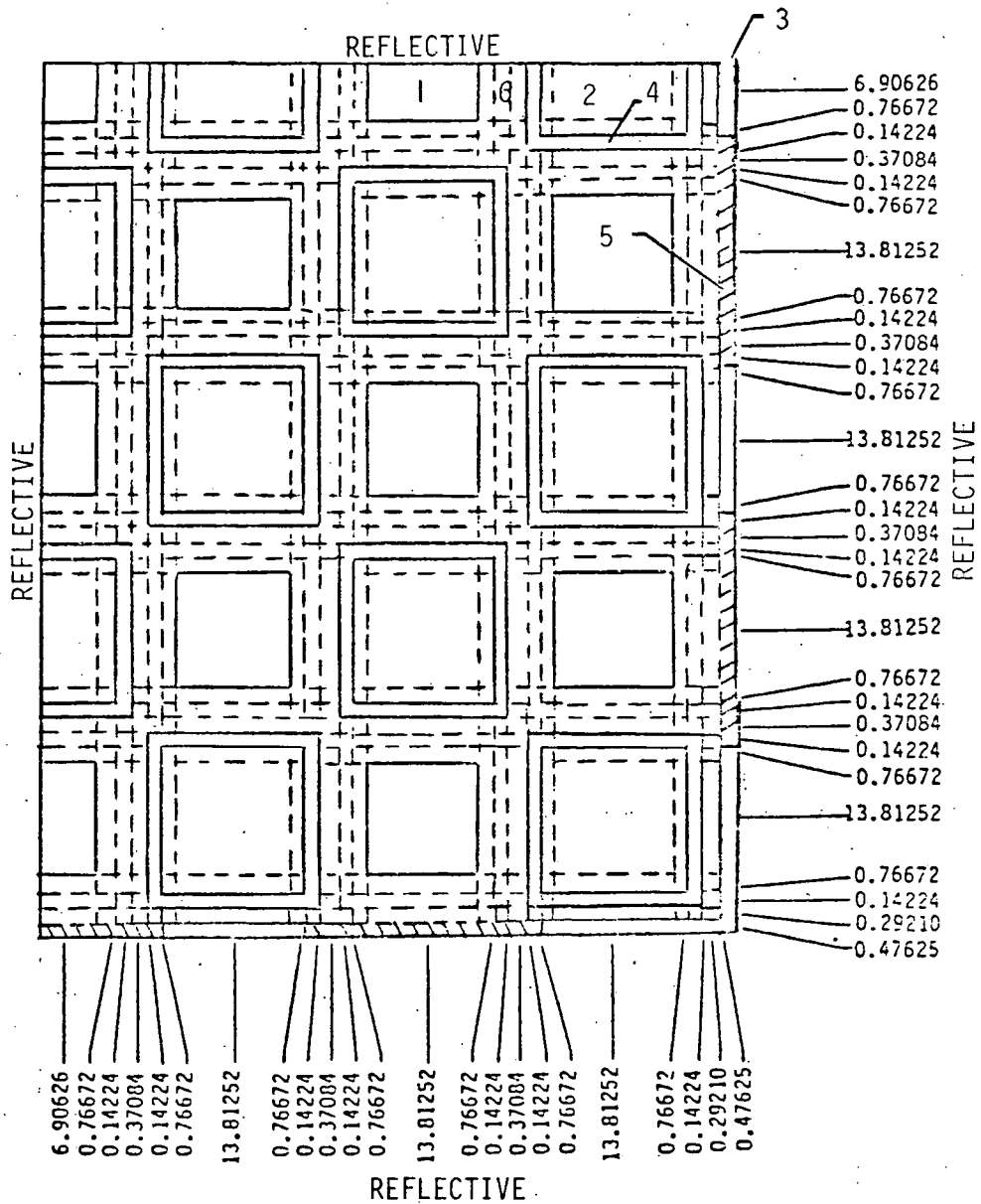

1. FUEL, INNER H₂O, Zr CHANNEL
2. FUEL, INNER H₂O, Zr CHANNEL, MIDDLE H₂O
3. OUTER WATER
4. ABSORBER MATERIAL
5. S.S. CLOSURE PLATE
6. OUTER A1, OUTER S.S., HOMOGENIZED H₂O

ALL UNITS ARE IN CENTIMETERS.

FIGURE 3.3-6. RACKS IN CONTACT WITH EACH OTHER



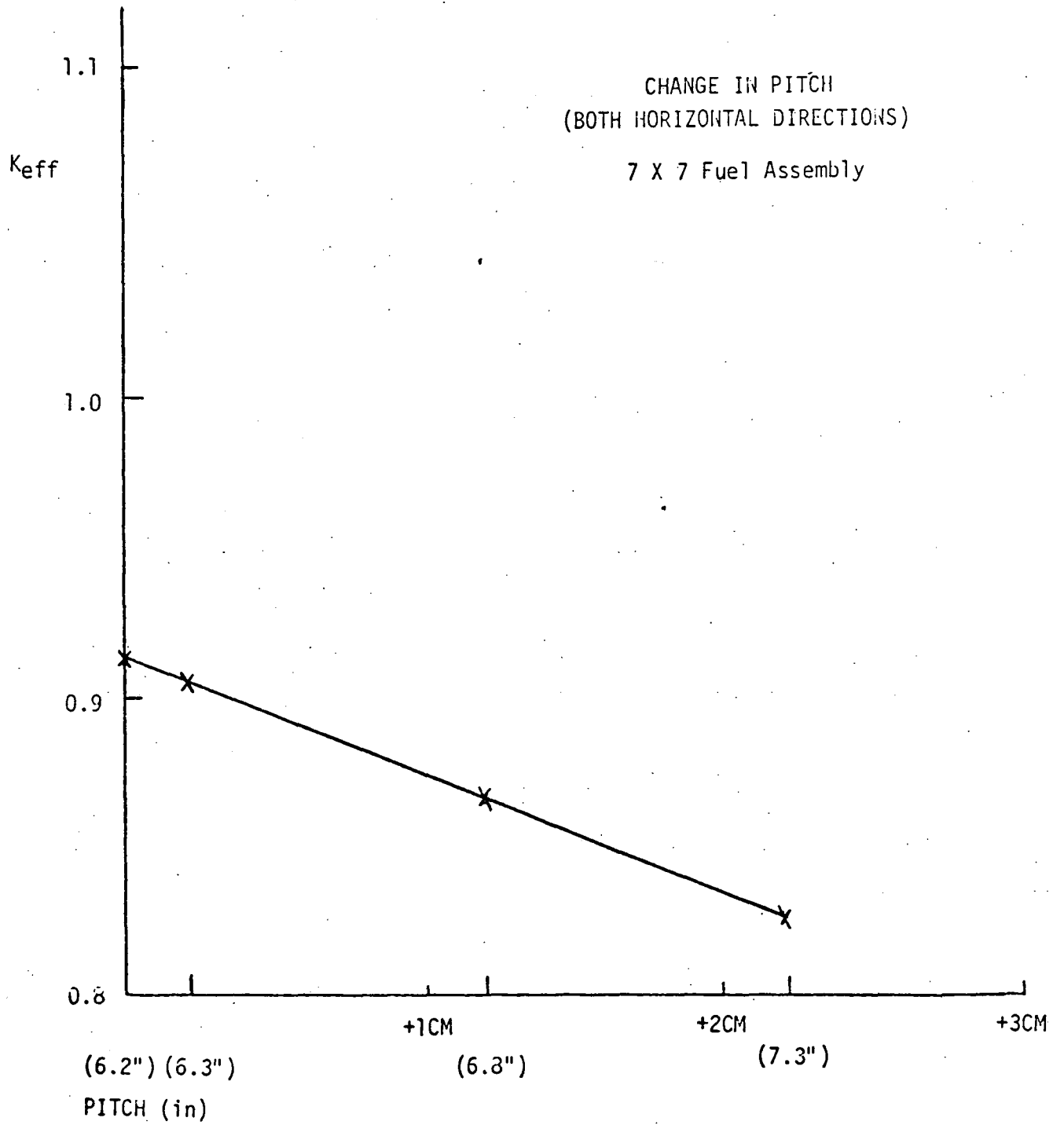
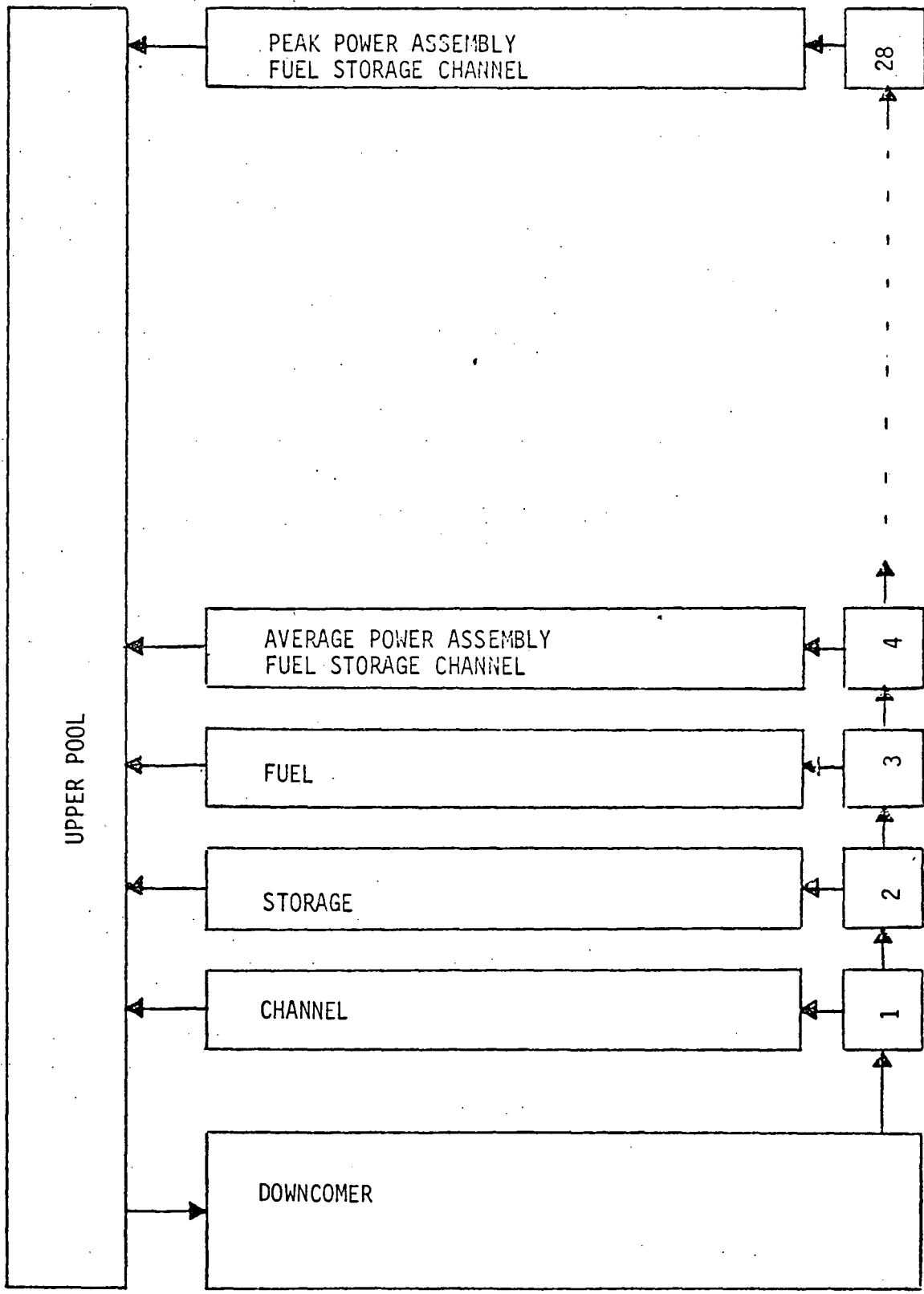

Figure 3.3-9
 K_{eff} VS CHANGE IN PITCH 3 3-29



DRESDEN
FLOW MODEL
NATURAL CIRCULATION

FIGURE 3.6-8:

3

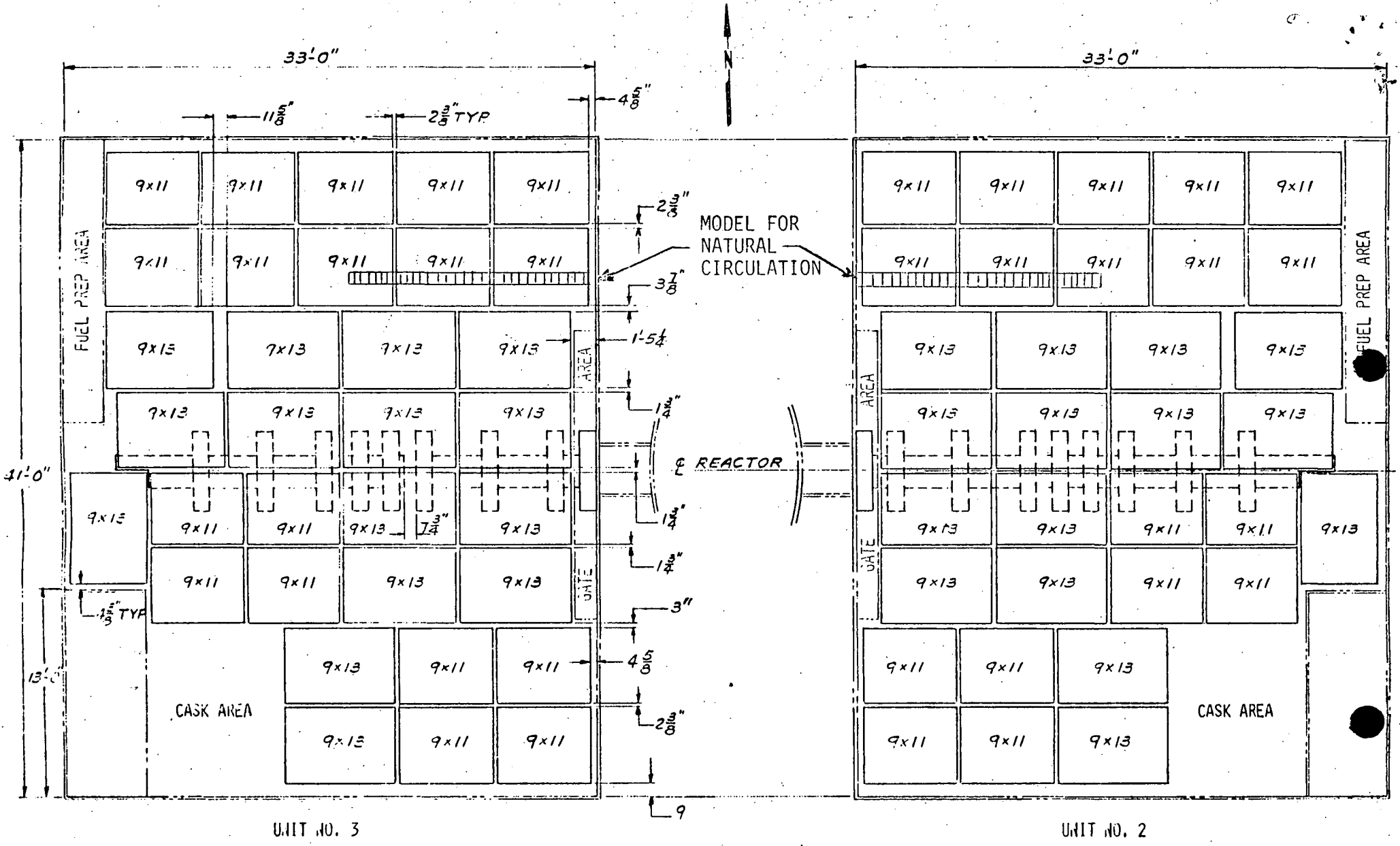

FIGURE 3.6-9: DRESDEN UNITS NO. 2 & 3
SPENT FUEL POOL MODEL
FOR NATURAL CIRCULATION

