

Non-Proprietary

Evaluations and Design Enhancements to Incorporate
Lessons Learned from Fukushima Dai-Ichi Nuclear Accident APR1400-E-P-NR-14005-NP. Rev. 1

Evaluations and Design Enhancements to Incorporate Lessons Learned from Fukushima Dai-Ichi Nuclear Accident

Revision 1

Non-Proprietary

March 2017

Copyright © 2017

**Korea Electric Power Corporation &
Korea Hydro & Nuclear Power Co., Ltd
All Rights Reserved**

REVISION HISTORY

Revision	Date	Sections or Page(s)	Description
0	December 2014	All	Initial Issue
1	March 2017	Table 4-1, items 4.1, 4.2, 9.3	Added reference COL item related to developing shutdown risk process and procedures consistent with NEI 12-06.
		Section 5.1.2.1	Modified content based on response to RAI 393-8432_Q13 Rev.1
		Section 5.1.2.2	Modified content based on response to RAI 393-8432_Q13 Rev.1
		Section 5.1.2.3	Removed information regarding shutdown mitigating strategies based on response to RAI 393-8432_Q13 Rev.1
		Section 5.1.2.3.1.1.2	Modified statement and added table about room temperatures
		Section 5.1.2.3.1.2.1	1. Typographical change based on response to RAI 297-8309_Q8 2. Modified statement and added table about room temperatures
		Section 5.1.2.3.1.2.3	Water source sufficiency for phase 2 operation has been changed from 12 to 11 days based on response to RAI 517-8670_Q41
		Section 5.1.2.3.3	Modified section and removed information regarding shutdown mitigating strategies based on response to RAI 393-8432_Q13 Rev.1
		Section 5.1.2.3.3.1	Modified title/section and removed information regarding shutdown mitigating strategies based on response to RAI 393-8432_Q13 Rev.1 and Q13 Rev.2
		Section 5.1.2.3.3.2	Modified content and removed information regarding shutdown mitigating strategies based on response to RAI 393-8432_Q13 Rev.1 and Q13 Rev.2
		Section 5.1.2.3.3.2	Added information based on response to RAI 407-8447_Q29
		Section 5.1.2.3.3.3	Modified title and removed information regarding shutdown mitigating strategies based on response to RAI 393-8432_Q13 Rev.1
Section 5.1.2.3.4	Removed information regarding shutdown mitigating strategies based on response to RAI 393-8432_Q13 Rev.1		

REVISION HISTORY

Revision	Date	Sections or Page(s)	Description
1	March 2017	Section 5.1.2.3.4.2	Modified title and content based on response to RAI 393-8432_Q13 Rev.1
		page 30	Deleted previous section 5.1.2.3.4.6 related to information regarding shutdown mitigating strategies
		Section 5.1.2.3.4.3	Modified the following based on response to RAI 393-8432_Q13 Rev.1 1.Modified title 2. Adjusted section number due to deletion of previous section 3. Content of succeeding section has been deleted to this section 4. Added information about FLEX pumps and mobile GTGs in the ending part
		page 31	Deleted previous section 5.1.2.3.4.6 related to information regarding shutdown mitigating strategies
		Section 5.1.2.4.1	Modified numerical data based on response to RAI 517-8670_Q41
		Section 5.1.2.4.1.1	Modified the following based on response to RAI 517-8670_Q41: 1. Modified numerical data 2. Added information. 3. Deleted sentence about non seismic piping.
		Section 5.1.2.4.1.2	Modified numerical data and some information based on response to RAI 517-8670_Q41
		Section 5.1.2.4.1.2	Added information for the SFP Makeup FLEX Pumps
		Section 5.1.2.4.2.1	Modified numerical data and some information based on response to RAI 517-8670_Q41
		Section 5.1.2.4.2.3	Modified numerical data and some information based on response to RAI 517-8670_Q41

REVISION HISTORY

Revision	Date	Sections or Page(s)	Description
1	March 2017	Sections 5.1.2.5	1. Modified title and contents by removing information regarding shutdown mitigating strategies based on response to RAI 393-8432_Q13 Rev.1 2. Corrected typographical errors based on response 393 to RAI -8432_Q13 Rev.2
		Sections 5.1.2.5.1	Modified title and content by removing information regarding shutdown mitigating strategies based on response to RAI 393-8432_Q13 Rev.1 and Rev.2
		Section 5.1.2.5.2 Section 5.1.2.5.2.1 Section 5.1.2.5.2.2	Content has been revised and 2 subsections have been inserted as additional information based on response to RAI 393-8432_Q13 Rev.1
		Section 5.1.2.5.2.3	Modified the following based on response to RAI 393-8432_Q13 Rev.1 and Rev.2 1. Section number: 5.1.2.5.3 to 5.1.2.5.2.3 2. Title and contents have been changed 3. Superseded the added information in RAI 401-8402_Q18 4. Superseded the added information in RAI 297-8309_Q1
		Section 5.1.2.5.3	Inserted section based on response to RAI 401-8402_Q19, 401-8402_Q19 Rev.1 and 393-8432_Q13R2
		Section 5.1.2.6.1.3	Specified the type of current and provided additional information for the emergency lightings.
		Section 5.1.2.6.2	Modified the following based on response to RAI response: 1. Added information on designing the RWT. 2. Modified numerical data
		Section 5.1.2.6.3	Deleted portion of content based on response to RAI 393-8432_Q13 Rev.1
		Section 5.1.3.2.1	Modified numerical data based on response to RAI 517-8670_Q41
		Section 5.1.3.2.2	Modified numerical data based on response to RAI 517-8670_Q41

REVISION HISTORY

Revision	Date	Sections or Page(s)	Description
1	March 2017	Table 5-2	Modified numerical data based on response to RAI 517-8670_Q41
		page 50	Deleted previous Table 5-3 to remove information regarding shutdown mitigating strategies based on response to RAI 393-8432_Q13 Rev.1
		Table 5-3	Modified information based on response to RAI 517-8670_Q41
		Table 5-4	Adjusted table number due to deletion of previous table (Table 5-3)
		Table 5-5	Adjusted table number and removed information regarding shutdown mitigating strategies based on response to RAI 393-8432_Q13 Rev.1
		Table 5-6	1. The following are changes based on response to RAI 393-8432_Q13 Rev.1: - Adjusted table number - Modified contents related to Core Cooling and RCS Inventory, and Containment Integrity 2. Deleted some information based on response to RAI 393-8432_Q13 Rev.2
		Table 5-7	1. Adjusted table number 2. Deleted duration time in items 2.1, 2.2, 2.3 for initial phase, transition phase, and final phase respectively. In addition, portion of item 2.2 has been deleted 3. In item 5.0, the isolation valves needed to be opened by manual operation for FLEX strategies have been specified 4. In item 5.1, the information regarding shutdown mitigating strategies has been deleted. 5. In item 2.2, transition phase extension has been changed from 12 days to 11 days 6. Modified some information based on response to RAI 393-8432_Q13 Rev.2

REVISION HISTORY

Revision	Date	Sections or Page(s)	Description
1	March 2017	Table 5-8	1. Adjusted table number 2. Modified statement in item 3.2.1.1 based on response to RAI 407-8447_Q25 Rev.1 3. Modified statement in item 3.2.1.5 based on response to RAI 401-8402_Q14 4. Editorial correction
		Table 5-9	1. Adjusted table number 2. Added information that borated water is sourced also from BAST 3. RWT water inventory minimum provision has been changed from 12 days to 11 days
		Table 5-10	Adjusted table number due to deletion of previous table (Table 5-3)
		pages 97, 98	Deleted previous Figure 5-2 to removed information regarding shutdown mitigating strategies based on response to RAI 393-8432_Q13 Rev.1
		Figure 5-2 Figure 5-3	1. Adjusted figure number 2. Replaced previous figure with revised figures (Figure 5-2 and Figure 5-3) to removed information regarding shutdown mitigating strategies based on response to RAI 393-8432_Q13 Rev.1
		page 99	Removed previous figures (Figure 5-4 and Figure 5-5) regarding shutdown mitigating strategies based on response to RAI 393-8432_Q13 Rev.1
		Section 6.1	Added information for overall description based on response to RAI 297-8309_Q1 and 333-8397_Q9
		Section 6.2.2.1	Modified contents based on response to RAI 393-8432_Q13 Rev.1
		Section 6.2.2.2	1. Modified content based on response to RAI 393-8432_Q13 Rev.1 2. Modified content based on response to RAI 297-8309_Q4 (initial version, Rev.1, and Rev. 2) 3. Added information based on response to RAI 297-8309_Q1
Section 6.2.3.1	Added information based on response to RAI 297-8309_Q1		

REVISION HISTORY

Revision	Date	Sections or Page(s)	Description
1	March 2017	Section 6.2.3.2	1. Modified content based on response to RAI 297-8309_Q4 (initial version, Rev.1, and Rev. 2) 2. Deleted portion of content based on response to RAI 393-8432_Q13 Rev.1 3. Modified content and added information based on response to RAI 297-8309_Q1
		Section 6.2.3.2	Modified numerical data based on response to RAI 517-8670_Q41
		Section 6.2.4.1	Modified numerical data based on response to RAI 517-8670_Q41
		Section 6.2.5.2	Modified numerical data based on response to RAI 517-8670_Q41
		Section 6.2.5.2	Modified content based on response to RAI 297-8309_Q4 (initial version, Rev.1, and Rev. 2)
		Section 6.2.9	Replaced previous content based on response to RAI 333-8397_Q9
		Section 6.2.10	Inserted section based on response to RAI 354-8416_Q10 (initial version, and Rev.1)
		Section 6.2.11	Inserted section based on response to RAI 407-8447_Q26 Rev.1
		Table 6-1	1. Updated DCD reference figures based on response to RAI 297-8309_Q1 2. Inserted 4 but deleted 9 entries based on response to 401-8402_Q21 (initial version and Rev.1)
		Table 6-2, 6-3, 6-4, and 6-5	Added Tables 6-2, 6-3, 6-4, and 6-5 for additional information
		Table 6-3	Modified some information and added note based on response to RAI 393-8432_Q13 Rev.2
		Figure 6-5	Replaced Figure 6-5 to correct information
Figure 6-7	Added Figure 6-7 for additional information		

REVISION HISTORY

Revision	Date	Sections or Page(s)	Description
1	March 2017	Section 8.0	Updated reference information
		Appendix A - A.1	Deleted portion of content regarding shutdown mitigating strategies based on response to RAI 393-8432_Q13 Rev.1
		Appendix A - A.4	Deleted subsection title "A.4.1" as editorial correction.
		page A2	Deleted content of succeeding section to previous A.4 regarding shutdown mitigating strategies based on response to RAI 393-8432_Q13 Rev.1
		page A5	Deleted content of succeeding section to A.5.2.2 regarding shutdown mitigating strategies based on response to RAI 393-8432_Q13 Rev.1
		page A19	Deleted Figure A-26, Figure A-27, and Figure A-28 based on response to RAI 393-8432_Q13 Rev.1
		Appendix B - Section B.2	Modified numerical data and added information based on response to RAI 517-8670_Q41
		Appendix B - Section B.4	Modified numerical data based on response to RAI 517-8670_Q41
		Appendix B - Table B-1	Modified numerical data based on response to RAI 517-8670_Q41
		Appendix B - Table B-2	Modified numerical data based on response to RAI 517-8670_Q41
		Appendix B - Table B-3	1. Modified contents of Table B-3 based on response to RAI 393-8432_Q13 Rev.1, and 407-8447_Q28 2. Modified Note 1 and deleted Note 2 of Table B-3 based on response to RAI 393-8432_Q13 Rev.1 3. Modified numerical data and some information based on response to RAI 517-8670_Q41
		Appendix B - Figure B-1	Modified numerical data in figure based on response to RAI 517-8670_Q41

This document was prepared for the design certification application to the U.S. Nuclear Regulatory Commission and contains technological information that constitutes intellectual property of Korea Hydro & Nuclear Power Co., Ltd. Copying, using, or distributing the information in this document in whole or in part is permitted only to the U.S. Nuclear Regulatory Commission and its contractors for the purpose of reviewing design certification application materials. Other uses are strictly prohibited without the written permission of Korea Electric Power Corporation and Korea Hydro & Nuclear Power Co., Ltd.

ABSTRACT

The APR1400 mitigating strategies and design enhancements to meet Near-Term Task Force recommendations and U.S. NRC regulatory orders, relative to the Beyond Design Basis External Event at Fukushima Dai-ichi Nuclear Power Plant, are described in this technical report. In developing the mitigating strategies and design enhancements, the APR1400 design has considered the interim staff guidance and industry guidance. Accordingly, the APR1400 DCD reflects the lessons learned from the Fukushima BDBEE and its impact assessment, including identification of COL items. Any potential changes from proposed rulemaking to occur after the APR1400 DCD submittal have been excluded from this technical report.

Specifically, this technical report addresses the Near-Term Task Force Tier 1, 2, and 3 recommendations, and the multiple design changes considered for the APR1400 are supported by extensive analysis and calculations to address the Fukushima BDBEE. These enhancements have been incorporated into the APR1400 design; however, the operational and programmatic aspects of the BDBEE will be addressed by COL applicants prior to fuel load. Incorporation of the design enhancements, as described in this technical report, increases the APR1400 plant reliability and safety against BDBEE.

TABLE OF CONTENTS

1.0	INTRODUCTION	1
2.0	PURPOSE.....	2
3.0	SCOPE	3
4.0	REGULATORY RECOMMENDATIONS AND REQUIREMENTS.....	4
5.0	STRATEGIES TO ACTION ITEMS FROM FUKUSHIMA DAI-ICHI EVENTS	23
5.1	Tier 1 Items.....	23
5.1.1	Recommendation 2.1 – Seismic and Flooding Re-Evaluation	23
5.1.2	Recommendations 4.1 and 4.2 – SBO and FLEX.....	23
5.1.3	Recommendation 7.1 – SFP Instrumentation.....	38
5.1.4	Recommendation 8 – Emergency Response.....	44
5.1.5	Recommendation 9.3 – Emergency Plan (only staffing and communications equipment portion in Tier 1).....	45
5.2	Tier 2 Items.....	45
5.2.1	Recommendation 7.2 – Safety-Related ac Electrical Power for the SFP Makeup System.....	45
5.2.2	Recommendation 7.3 – Plant Technical Specifications	45
5.2.3	Recommendation 7.4 – Seismically Qualified Spent Fuel Pool Spray System.....	45
5.2.4	Recommendation 7.5 – Spent Fuel Pool Actions Related to Recommendations 7.1 through 7.4.....	46
5.2.5	Recommendation 9.3 – Emergency Preparedness Regulatory Actions (remaining portions of Recommendation 9.3, except Emergency Response Data System – ERDS capability addressed in Tier 3).....	46
5.2.6	Recommendation 2.1 – Other External Events	46
5.3	Tier 3 Items (and Other Items).....	46
5.3.1	Recommendation 2.2 – Ten-Year Confirmation of Seismic and Flooding Hazards (dependent on Recommendation 2.1).....	46
5.3.2	Recommendation 3 – Potential Enhancements to the Capability to Prevent or Mitigate Seismically-Induced Fires and Floods (Long-Term Evaluation)	46
5.3.3	Recommendation 5.2 – Reliable Hardened Vents for Other Containment Designs (Long-Term Evaluation)	46
5.3.4	Recommendation 6 – Hydrogen Control and Mitigation inside Containment or in Other Buildings	47
5.3.5	Recommendations 9.1 and 9.2 – Emergency Preparedness (EP) Enhancements for Prolonged SBO and Multiunit Events	47
5.3.6	Recommendation 9.3 – ERDS Capability.....	47
5.3.7	Recommendation 10 – Additional EP Topic for Prolonged SBO and Multiunit Events	47

5.3.8	Recommendation 11 – EP Topics for Decision-Making, Radiation Monitoring, and Public Education	47
5.3.9	Recommendation 12.1 – Reactor Oversight Process Modifications to Reflect the Recommended Defense-in-Depth Framework	47
5.3.10	Recommendation 12.2 – Staff Training on Severe Accidents and Resident Inspector Training on SAMGs.....	47
5.3.11	Additional Recommendations	47
6.0	DESIGN FEATURES AND PROGRAMS TO ADDRESS BDBEE.....	100
6.1	Overall Description	100
6.2	Specific Design Enhancements and Programs	100
6.2.1	Beyond Design Basis Seismic and Flood Protection	100
6.2.2	Primary Side FLEX Pump(s) and Connections	100
6.2.3	Spent Fuel Pool – Makeup Line and Spray Line Enhancements	101
6.2.4	SFP Level Instrumentation	102
6.2.5	AFWS Secondary Side FLEX Pump Connection	103
6.2.6	Electric Power Supply System.....	104
6.2.7	Operational Program, Procedures, and Training	105
6.2.8	Emergency Procedures	105
6.2.9	Storage of FLEX Equipment.....	105
6.2.10	Installed equipment and tanks utilized in the mitigation strategies.....	106
6.2.11	Connections for FLEX strategies	107
7.0	CONCLUSION	120
8.0	REFERENCES	121

LIST OF TABLES

Table 4-1	Post-Fukushima NRC Recommendations and Requirements (1 of 18).....	5
Table 5-1	Sequence of Events for Core Cooling (Full-Power Operation) (1 of 2).....	48
Table 5-2	Water Volume Source and Requirements for SG Feedwater.....	50
Table 5-3	FLEX Capability – Spent Fuel Pool Cooling Summary	51
Table 5-4	480 V and 4.16 kV Mobile GTG Electrical Load Summary List (in kW)	52
Table 5-5	Summary of Fuel Oil Demand (most limiting).....	53
Table 5-6	APR1400 FLEX Capability Summary (1 of 3)	54
Table 5-7	Conformance with JLD-ISG-2012-01, Rev. 0 (1 of 5).....	57
Table 5-8	Conformance with NEI 12-06, Rev. 0 (1 of 20).....	62
Table 5-9	Conformance with NEI 12-06, Rev. 0 – Tables D-1, D-2, and D-3 (1 of 4).....	82
Table 5-10	Conformance with NEI 12-02, Rev. 1 (1 of 11).....	86
Table 6-1	External Connection Components for BDBEE (1 of 2).....	108
Table 6-2	List of Installed Safety Related Pumps and Valves for BDBEE (1 of 2).....	110
Table 6-3	List of On-site FLEX Equipment for BDBEE.....	112
Table 6-4	List of Off-site FLEX Equipment for BDBEE.....	113
Table 6-5	List of Connection for FLEX strategies.....	114

LIST OF FIGURES

Figure 5-1	Timeline of the APR1400 FLEX Strategy for Full-Power Operation	97
Figure 5-2	Containment Pressure for Full Power (RCP Seal LOCA).....	98
Figure 5-3	Containment Temperature for Full Power (RCP Seal LOCA)	99
Figure 6-1	Primary Side FLEX Pump Connection into the Safety Injection System.....	115
Figure 6-2	FLEX Pump Suction Source for SFP Makeup and Spray Line.....	116
Figure 6-3	Connection for SFP Makeup and Spray Line	116
Figure 6-4	Layout of SFP Makeup and SFP Spray Line Connections	117
Figure 6-5	Water Supply System to the Secondary Side of SG.....	118
Figure 6-6	Fuel Oil Supply System to FLEX Pumps	118
Figure 6-7	Flow Path for FLEX Connection to Deliver Water to Containment for ECSBS.....	119

LIST OF APPENDICES

APPENDIX. A SUPPORTING ANALYSIS RESULTS FOR THE OPERATIONAL STRATEGY FOR CORE COOLINGAi

APPENDIX. B SPENT FUEL POOL TIME TO BOIL AND MAKEUP ANALYSIS.....Bi

APPENDIX. C 480 V AND 4.16 KV MOBILE GTG ELECTRICAL LOADINGSCi

ACRONYMS AND ABBREVIATIONS

AAC	alternate alternating current
ac	alternating current
ACP	auxiliary charging pump
AFWP	auxiliary feedwater pump
AFAS	auxiliary feedwater actuation signal
AFWS	auxiliary feedwater system
AFWST	auxiliary feedwater storage tank
AHU	air handling unit
ANPR	Advance Notice of Proposed Rulemaking
ANS	American Nuclear Society
ANSI	American National Standards Institute
AOP	abnormal operating procedure
AOV	air-operated valve
APR	advanced power reactor
BDB	beyond design basis
BDBEE	beyond design basis external event
BWR	boiling water reactor
CAV	cumulative absolute velocity
CCW	component cooling water
CEUS	central and eastern United States
CEUS-SSC	CEUS seismic source characterization
CFR	Code of Federal Regulations
CIV	containment isolation valve
COL	combined license
COLA	combined license application
CP	construction permit
DBA	design basis accident
dc	direct current
DCD	design control document
EA	Enforcement Action
EDG	emergency diesel generator
ECSBS	emergency containment spray backup subsystem
EDMG	extensive damage mitigation guideline
EFW	emergency feedwater

ELAP	extended loss of ac power
EOP	emergency operating procedure
EP	emergency preparedness
EPRI	Electric Power Research Institute
EPZ	emergency planning zone
ERDS	emergency response data system
ESW	essential service water
FEMA	Federal Emergency Management Agency
FIRS	foundation input response spectra
FLEX	diverse and flexible coping strategies
FSG	FLEX support guideline
GDC	General Design Criteria
GMRS	ground motion response spectra
GTG	gas turbine generator
GWR	guided wave radar
HPCI	high-pressure coolant injection
HVAC	heating, ventilation and air conditioning
Hx	heat exchanger
I&C	instrumentation and control
IEEE	Institute of Electrical and Electronics Engineers
IRWST	in-containment refueling water storage tank
ISG	interim staff guidance
KHNP	Korea Hydro & Nuclear Power Company Ltd.
LOOP	loss of offsite power
LOLA	loss of large area
LTOP	low-temperature overpressurization protection
LOSCS	loss of shutdown cooling system
LUHS	loss of normal access to ultimate heat sink
MCC	motor control center
MCR	main control room
MSADV	main steam atmospheric dump valve
MSSV	main steam safety valve
MOV	motor-operated valve
MTC	moderator temperature coefficient
NA	not applicable
NCC	natural circulation cooling

NEI	Nuclear Energy Institute
NRC	Nuclear Regulatory Commission
NTTF	Near-Term Task Force
OSC	operational support center
PMF	probable maximum flood
PORV	power-operated relief valve
POSRV	pilot-operated safety relief valve
PSHA	probabilistic seismic hazard analysis
PWR	pressurized water reactor
PZR	pressurizer
RAI	request for additional information
RAT	reserve auxiliary transformer
RCIC	reactor core isolation cooling
RCS	reactor coolant system
RCP	reactor coolant pump
RG	Regulatory Guide
RFI	Request for Information
RHR	residual heat removal
RPS	reactor protection system
RSR	remote shutdown room
RV	reactor vessel
RWT	raw water tank
SAMG	severe accident management guidelines
SAT	systematic approach to training
SBO	station blackout
SCS	shutdown cooling system
SFP	spent fuel pool
SG	steam generator
SIP	safety injection pump
SIT	safety injection tank
SSC	structure, system, or component
TDAFWP	turbine-driven auxiliary feedwater pump
TDH	total dynamic head
TDR	time domain reflectometry
TSC	technical support center
UHS	ultimate heat sink

UPC	ultimate pressure capacity
UPS	uninterruptible power system
VBPSS	vital bus power supply system

1.0 INTRODUCTION

The March 11, 2011 earthquake and subsequent tsunami off the Pacific coast of Japan (“Great Tohoku Earthquake”) exceeded the seismic and tsunami design bases of the Fukushima Dai-ichi Nuclear Power Plant. The event resulted in major damage at the site. Subsequent evaluation by regulatory and industry experts resulted in insights that nuclear plants should have additional capability to withstand beyond-design-basis external events (BDBEEs). This capability would enhance protection against accidents resulting from natural phenomena, mitigate the consequences of such accidents, and enhance emergency preparedness. It reflects a “diverse and flexible” coping strategy to increase the defense-in-depth safety principle that has long been a foundation of the commercial nuclear power industry.

Korea Hydro & Nuclear Power Co., Ltd. (KHNP) has evaluated post-Fukushima insights in terms of its Advanced Power Reactor 1400 (APR1400) design. Sections 2.0 and 3.0 of this report summarize the purpose and scope, respectively. Section 4.0 summarizes applicable regulatory requirements and the potential effect on the APR1400 licensing documentation. Section 5.0 provides technical description of how the APR1400 addresses post-Fukushima insights. Section 6.0 identifies design features and their impact on the Design Control Document (DCD) and the combined license (COL) applicant. Section 7.0 provides the report’s overall conclusions.

2.0 PURPOSE

The purpose of this report is to address requirements and guidance provided by the U.S. Nuclear Regulatory Commission (NRC) in a series of Commission papers (SECY), NRC Orders (provided via Enforcement Actions, EAs), and Interim Staff Guidance (ISG) after the Fukushima event. In addition, industry initiatives identified by the Nuclear Energy Institute (NEI) have been considered in the development of this report. The applicable requirements for the APR1400 design are summarized in Table 4-1.

3.0 SCOPE

This technical report addresses the lessons learned from the Fukushima event, which form an integral part of the APR1400 design. This document also identifies actions associated with insights from the Fukushima event. Any potential changes from proposed rulemaking that are scheduled to occur after the APR1400 is submitted for NRC design certification are outside of the scope of this report.

4.0 REGULATORY RECOMMENDATIONS AND REQUIREMENTS

This section addresses post-Fukushima NRC recommendations/requirements and actions by KHNP and/or the COL applicant for each recommendation and requirement. In this section, the following post-Fukushima NRC recommendations and requirements are addressed:

- SECY 11-0093, “Recommendations for Enhancing Reactor Safety in the 21st Century, The Near-Term Task Force Review of Insights from the Fukushima Dai-ichi Accident (Near-Term Task Force (NTTF) Recommendations)” (Reference 1)
- SECY-11-0137, “Prioritization of Recommended Actions to be Taken in Response to Fukushima Lessons Learned” (Reference 2)
- SECY-12-0025, “Proposed Orders and Requests for Information in Response to Lessons Learned from Japan’s March 11, 2011, Great Tohoku Earthquake and Tsunami” (Reference 3)
- SECY-12-0095, “Tier 3 Program Plans and 6-Month Status Update in Response to Lessons Learned from Japan’s March 11, 2011, Great Tohoku Earthquake and Subsequent Tsunami” (Reference 4)
- NRC Order EA-12-049, “Order Modifying Licenses with Regard to Requirements for Mitigation Strategies for Beyond-Design-Basis External Events” (Reference 5)
- NRC Order EA-12-051, “Reliable Spent Fuel Pool Instrumentation” (Reference 6)

Table 4-1 provides a cross-reference to sections in this report where KHNP actions to address the recommendations specified in the above NRC documents are described. This table also lists those applicable DCD sections that address the recommendations and provides a brief summary of applicable actions for each recommendation. The post-Fukushima NRC recommendations that are not applicable to either the APR1400 DCD or COL applicant(s) are also identified in the table.

Table 4-1 Post-Fukushima NRC Recommendations and Requirements (1 of 18)

NTTF Rec. No	NRC Recommendations/Requirements in SECY-11-0093, SECY-11-0137, SECY-12-0025, SECY-12-0095, EA-12-049, EA-12-051	APR1400 Design	Applicable DCD Section	COL Action	Note
Tier 1 (Actions to be taken without delay)					
2.1	<p>Seismic Reevaluation</p> <p>a) Evaluate the potential impacts of the newly released Central and Eastern United States Seismic Source Characterization (CEUS-SSC) model, with potential local and regional refinements as identified in the CEUS-SSC model, on the seismic hazard curves and the site-specific ground motion response spectra (GMRS)/foundation input response spectra (FIRS). For re-calculation of the probabilistic seismic hazard analysis (PSHA), please follow either the cumulative absolute velocity (CAV) filter or minimum magnitude specifications outlined in Attachment 1 to Seismic Enclosure 1 of the March 12, 2012 letter "Request for information pursuant to Title 10 of the Code of Federal Regulations 50.54(f) regarding Recommendations 2.1, 2.3, and 9.3, of the near-term task force review of insights from the Fukushima Dai-ichi accident." (ML12053A340).</p> <p>b) In your response, please identify the method you selected from the above choices to perform the evaluation. Modify and submit the site-specific GMRS and FIRS changes, as necessary, given the evaluation performed in part (a) above. Provide the basis supporting your position.</p>	NA	NA	COL 19.3(1)	Request for information via 50.54(f) letter.

Table 4-1 Post-Fukushima NRC Recommendations and Requirements (2 of 18)

NTTF Rec. No	NRC Recommendations/Requirements in SECY-11-0093, SECY-11-0137, SECY-12-0025, SECY-12-0095, EA-12-049, EA-12-051	APR1400 Design	Applicable DCD Section	COL Action	Note
2.1	<p>Flooding Reevaluation</p> <ul style="list-style-type: none"> Perform a reevaluation of all appropriate external flooding sources, including the effects from local intense precipitation on the site, probable maximum flood (PMF) on stream and rivers, storm surges, seiches, tsunami, and dam failures. It is requested that the reevaluation apply present-day regulatory guidance and methodologies being used for ESP and COL reviews including current techniques, software, and methods used in present-day standard engineering practice to develop the flood hazard. 	NA	NA	COL 19.3(2)	Request for information via 50.54(f) letter.
2.3	<p>Seismic Walkdowns</p> <ul style="list-style-type: none"> Perform seismic walkdowns in order to identify and address plant specific degraded, non-conforming, or unanalyzed conditions and verify the adequacy of strategies, monitoring, and maintenance programs such that the nuclear power plant can respond to external events. The walkdown will verify current plant configuration with the current licensing basis, verify the adequacy of current strategies, maintenance plans, and identify degraded, non-conforming, or unanalyzed conditions. 	NA	NA	NA	Request for information via 50.54(f) letter.

Table 4-1 Post-Fukushima NRC Recommendations and Requirements (3 of 18)

NTTF Rec. No	NRC Recommendations/Requirements in SECY-11-0093, SECY-11-0137, SECY-12-0025, SECY-12-0095, EA-12-049, EA-12-051	APR1400 Design	Applicable DCD Section	COL Action	Note
2.3	<p>Flooding Walkdowns</p> <ul style="list-style-type: none"> • Perform flood protection walkdowns using an NRC-endorsed walkdown methodology, • Identify and address plant-specific degraded, non-conforming, or unanalyzed conditions as well as cliff-edge effects through the corrective action program and consider these findings in the Recommendation 2.1 hazard evaluations, as appropriate, • Identify any other actions taken or planned to further enhance the site flood protection, • Verify the adequacy of programs, monitoring and maintenance for protection features, and, • Report to the NRC the results of the walkdowns and corrective actions taken or planned. 	NA	NA	NA	Request for information via 50.54(f) letter.
4.1	<p>Station Blackout (SBO)</p> <p>(NTTF Recommendations) Initiate rulemaking to revise 10 CFR 50.63 to require each operating and new reactor licensee to (1) establish a minimum coping time of 8 hours for a loss of all ac power, (2) establish the equipment, procedures, and training necessary to implement an “extended loss of all ac” coping time of 72 hours for core and spent fuel pool cooling and for reactor coolant system and primary containment integrity as needed, and (3) preplan and prestage offsite resources to support uninterrupted core and spent fuel pool cooling, and reactor coolant system and containment integrity as needed, including the ability to deliver the equipment to the site in the time period allowed for extended coping, under conditions involving significant degradation of</p>	See NTTF Recommendations 4.1 and 4.2 in Subsection 5.1.2	19.3.2.3	COL 19.3(3), 19.3(4), 19.3(5), and 19.3(17)	

Table 4-1 Post-Fukushima NRC Recommendations and Requirements (4 of 18)

NTTF Rec. No	NRC Recommendations/Requirements in SECY-11-0093, SECY-11-0137, SECY-12-0025, SECY-12-0095, EA-12-049, EA-12-051	APR1400 Design	Applicable DCD Section	COL Action	Note
	offsite transportation infrastructure associated with significant natural disasters.				
4.2	<p>Mitigation Strategies for Beyond-Design-Basis External Events (EA-12-049)</p> <p>(1) Licensees shall develop, implement and maintain guidance and strategies to maintain or restore core cooling, containment and SFP cooling capabilities following a beyond-design-basis external event.</p> <p>(2) These strategies must be capable of mitigating a simultaneous loss of all alternating current (ac) power and loss of normal access to the ultimate heat sink and have adequate capacity to address challenges to core cooling, containment, and SFP cooling capabilities at all units on a site subject to this Order.</p> <p>(3) Licensee must provide reasonable protection for the associated equipment from external events. Such protection must demonstrate that there is adequate capacity to address challenges to core cooling, containment, and SFP cooling capabilities at all units on a site subject to this order.</p> <p>(4) Licensee must be capable of implementing the strategies in all modes.</p> <p>(5) Full compliance shall include procedures, guidance, training, and acquisition, staging, or installation of equipment needed for the strategies.</p>	See NTTF Recommendation 4.2 in Subsection 5.1.2	19.3.2.3	COL 19.3(3), 19.3(4), 19.3(5), and 19.3(17)	

Table 4-1 Post-Fukushima NRC Recommendations and Requirements (5 of 18)

NTTF Rec. No	NRC Recommendations/Requirements in SECY-11-0093, SECY-11-0137, SECY-12-0025, SECY-12-0095, EA-12-049, EA-12-051	APR1400 Design	Applicable DCD Section	COL Action	Note
5.1	<p>Reliable Hardened Vents for Mark I and Mark II containments Boiling-Water Reactor (BWR) Mark I and Mark II containments shall have a reliable hardened vent to remove decay heat and maintain control of containment pressure within acceptable limits following events that result in the loss of active containment heat removal capability or prolonged Station Blackout (SBO). The hardened vent system shall be accessible and operable under a range of plant conditions, including a prolonged SBO and inadequate containment cooling.</p>	NA	NA	NA	
7.1	<p>SFP Instrumentation (EA-12-051 to COL Holder) Licensee requires reliable indication of the water level in associate spent fuel storage capable of supporting identification of the following pool water level conditions by trained personnel: (1) level that is adequate to support operation of the normal fuel pool cooling system, (2) level that is adequate to provide substantial radiation shielding for a person standing on the spent fuel pool operating deck, and (3) level where fuel remains covered and actions to implement makeup water addition should no longer be deferred. 1. The spent fuel pool level instrumentation shall include the following design features:</p>	See NTTF Recommendation Item 7.1 in Subsection 5.1.3	19.3.2.4	COL 19.3(6)	

Table 4-1 Post-Fukushima NRC Recommendations and Requirements (6 of 18)

NTTF Rec. No	NRC Recommendations/Requirements in SECY-11-0093, SECY-11-0137, SECY-12-0025, SECY-12-0095, EA-12-049, EA-12-051	APR1400 Design	Applicable DCD Section	COL Action	Note
	<p>1.1 Arrangement: The spent fuel pool level instrument channels shall be arranged in a manner that provides reasonable protection of the level indication function against missiles that may result from damage to the structure over the spent fuel pool. This protection may be provided by locating the safety-related instruments to maintain instrument channel separation within the spent fuel pool area, and to utilize inherent shielding from missiles provided by existing recesses and corners in the spent fuel pool structure.</p> <p>1.2 Qualification: The level instrument channels shall be reliable at temperature, humidity, and radiation levels consistent with the spent fuel pool water at saturation conditions for an extended period.</p> <p>1.3 Power supplies: Instrumentation channels shall provide for power connections from sources independent of the plant alternating current (ac) and direct current (dc) power distribution systems, such as portable generators or replaceable batteries. Power supply designs should provide for quick and accessible connection of sources independent of the plant ac and dc power distribution systems. Onsite generators used as an alternate power source and replaceable batteries used for instrument channel power shall have sufficient capacity to maintain the level indication function until</p>				

Table 4-1 Post-Fukushima NRC Recommendations and Requirements (7 of 18)

NTTF Rec. No	NRC Recommendations/Requirements in SECY-11-0093, SECY-11-0137, SECY-12-0025, SECY-12-0095, EA-12-049, EA-12-051	APR1400 Design	Applicable DCD Section	COL Action	Note
	<p>offsite resource availability is reasonably assured.</p> <p>1.4 Accuracy: The instrument shall maintain its designed accuracy following a power interruption or change in power source without recalibration.</p> <p>1.5 Display: The display shall provide on-demand or continuous indication of spent fuel pool water level.</p>				
	<p>2. The spent fuel pool instrumentation shall be maintained available and reliable through appropriate development and implementation of a training program. Personnel shall be trained in the use and the provision of alternate power to the safety-related level instrument channels.</p>				
8	<p>Strengthening and integration of emergency operating procedures, severe accident management guidelines (SAMGs), and extensive damage mitigation guidelines (NTTF Recommendations)</p> <p>1. Order licensees to modify the EOP technical guidelines (required by Supplement 1, "Requirements for Emergency Response Capability," to NUREG-0737, issued January 1983 (GL 82-33), to (1) include EOPs, SAMGs, and EDMGs in an integrated manner, (2) specify clear command and control strategies for their implementation, and (3) stipulate appropriate qualification and training for those who make decisions during emergencies.</p>	NA	NA	COL 19.3(7)	

Table 4-1 Post-Fukushima NRC Recommendations and Requirements (8 of 18)

NTTF Rec. No	NRC Recommendations/Requirements in SECY-11-0093, SECY-11-0137, SECY-12-0025, SECY-12-0095, EA-12-049, EA-12-051	APR1400 Design	Applicable DCD Section	COL Action	Note
	<ol style="list-style-type: none"> 2. Modify Section 5.0, Administrative Controls,” of the Standard Technical Specifications for each operating reactor design to reference the approved EOP technical guidelines for that plant design. 3. Order licensees to modify each plant’s technical specifications to conform to the above changes. 4. Initiate rulemaking to require more realistic, hands-on training and exercises on SAMGs and EDMGs for all staff expected to implement the strategies and those licensee staff expected to make decisions during emergencies, including emergency coordinators and emergency directors. 				
9.3	<p>Emergency Preparedness (SECY-12-0025, DCD RAI 644-6516) Communications</p> <ol style="list-style-type: none"> 1. Provide an assessment of the current communications systems and equipment used during an emergency event to identify any enhancements that may be needed to ensure communications are maintained during a large scale natural event meeting the conditions described above. The assessment should: <ul style="list-style-type: none"> • Identify any planned or potential improvements to existing onsite communications systems and their required normal and/or backup power supplies, 	NA	NA	COL 19.3(8)	

Table 4-1 Post-Fukushima NRC Recommendations and Requirements (9 of 18)

NTTF Rec. No	NRC Recommendations/Requirements in SECY-11-0093, SECY-11-0137, SECY-12-0025, SECY-12-0095, EA-12-049, EA-12-051	APR1400 Design	Applicable DCD Section	COL Action	Note
	<ul style="list-style-type: none"> • Identify any planned or potential improvements to existing offsite communications systems and their required normal and/or backup power supplies, • Provide a description of any new communications system(s) or technologies that will be deployed based upon the assumed conditions described above, and • Provide a description of how the new and/or improved systems and power supplies will be able to provide for communications during a loss of all ac power, <p>2. Describe any interim actions that have been taken or are planned to be taken to enhance existing communications systems power supplies until the communications assessment and the resulting actions are complete,</p> <p>3. Provide an implementation schedule of the time needed to conduct and implement the results of the communications assessment.</p>				
9.3	<p>Staffing</p> <p>1. Provide an assessment of the onsite and augmented staff needed to respond to a large scale natural event meeting the conditions described above. This assessment should include a discussion of the onsite and augmented staff available to implement the strategies as discussed in the emergency plan and/or described in plant operating procedures.</p>	NA	NA	COL 19.3(9)	

Table 4-1 Post-Fukushima NRC Recommendations and Requirements (10 of 18)

NTTF Rec. No	NRC Recommendations/Requirements in SECY-11-0093, SECY-11-0137, SECY-12-0025, SECY-12-0095, EA-12-049, EA-12-051	APR1400 Design	Applicable DCD Section	COL Action	Note
	<p>The following functions are requested to be assessed:</p> <ul style="list-style-type: none"> • How onsite staff will move back-up equipment (e.g., pumps, generators) from alternate onsite storage facilities to repair locations at each reactor as described in the order regarding the NTTF Recommendation 4.2. It is requested that consideration be given to the major functional areas of NUREG-0654, Table B-1 such as plant operations and assessment of operational aspects, emergency direction and control, notification/ communication, radiological accident assessment, and support of operational accident assessment, as appropriate. • New staff or functions identified as a result of the assessment. • Collateral duties (personnel not being prevented from timely performance of their assigned functions). <p>2. Provide an implementation schedule of the time needed to conduct the onsite and augmented staffing assessment. If any modifications are determined to be appropriate, please include in the schedule the time to implement the changes.</p> <p>3. Identify how the augmented staff would be notified given degraded communications capabilities.</p>				

Table 4-1 Post-Fukushima NRC Recommendations and Requirements (11 of 18)

NTTF Rec. No	NRC Recommendations/Requirements in SECY-11-0093, SECY-11-0137, SECY-12-0025, SECY-12-0095, EA-12-049, EA-12-051	APR1400 Design	Applicable DCD Section	COL Action	Note
	<p>4. Identify the methods of access (e.g., roadways, navigable bodies of water and dockage, airlift, etc.) to the site that are expected to be available after a widespread large scale natural event.</p> <p>5. Identify any interim actions that have been taken or are planned prior to the completion of the staffing assessment.</p> <p>6. Identify changes that have been made or will be made to your emergency plan regarding the on-shift or augmented staffing changes necessary to respond to a loss of all ac power, multi-unit event, including any new or revised agreements with offsite resource providers (e.g., staffing, equipment, transportation, etc.).</p>				
-	<p>Filtration of Containment Vents</p> <p>The staff is considering requiring the filtration of containment vents to reduce the spread of radioactive contamination during a beyond-design-basis event. The staff plans to provide the Commission a notation vote paper on these policy issues in July 2012.</p> <p>At this time, the staff is proposing regulatory action to require that all operating BWR facilities with Mark I and Mark II containments have a reliable hardened venting capability, without filters, for events that can lead to core damage.</p>	NA	NA	NA	
-	<p>Loss of Ultimate Heat Sink (SECY-12-0025)</p> <p>1. Include UHS systems in the reevaluation and walkdowns of site-specific seismic and flooding hazards using the methodology described in</p>				

Table 4-1 Post-Fukushima NRC Recommendations and Requirements (12 of 18)

NTTF Rec. No	NRC Recommendations/Requirements in SECY-11-0093, SECY-11-0137, SECY-12-0025, SECY-12-0095, EA-12-049, EA-12-051	APR1400 Design	Applicable DCD Section	COL Action	Note
	SECY-11-0137, and identify actions that have been taken, or are planned, to address plant-specific issues associated with the updated seismic and flooding hazards in conjunction with the resolution of NTTF Recommendations 2.1 and 2.3.	NA	NA	COL 19.3(1) and 19.3(2)	
	2. Incorporate the loss of UHS as a design assumption in the resolution of station blackout rulemaking activities in conjunction with the resolution of NTTF Recommendation 4.1.	See NTTF Recommendation 4.2 in Subsection 5.1.2	19.3.2.3	COL 19.3(3), 19.3(4), 19.3(5), and 19.3(17)	
	3. Provide mitigating measures for beyond-design-basis external events to also include a loss of access to the normal UHS in conjunction with the resolution of NTTF Recommendation 4.2.	See NTTF Recommendation 4.2 in Subsection 5.1.2	19.3.2.3	COL 19.3(3), 19.3(4), 19.3(5), and 19.3(17)	
	4. Include UHS systems in the reevaluation of site-specific natural external hazards, and identify actions that have been taken, or are planned, to address plant-specific issues associated with the updated hazards in conjunction with the resolution of the new Tier 2 Recommendation 2.1 activity described in Enclosure 3, "Other Natural External Hazards."	NA	NA	Refer to Tier 2 Recommendation	
Tier 2 (Actions do not require long-term study and can be initiated when sufficient technical information and applicable resources become available)					
2.1	Other External Events Protections (SECY-12-0025) 1. Continue stakeholder interactions to discuss the technical basis and acceptance criteria for conducting a reevaluation of site-specific	No Action	NA	NA	

Table 4-1 Post-Fukushima NRC Recommendations and Requirements (13 of 18)

NTTF Rec. No	NRC Recommendations/Requirements in SECY-11-0093, SECY-11-0137, SECY-12-0025, SECY-12-0095, EA-12-049, EA-12-051	APR1400 Design	Applicable DCD Section	COL Action	Note
	<p>external natural hazards. These interactions will also help to define guidelines for the application of current regulatory guidance and methodologies being used for early site permit and combined license reviews to the reevaluation of hazards at operating reactors.</p> <p>2. Develop and issue a request for information to licensees pursuant to 10 CFR 50.54(f) to (1) reevaluate site-specific external natural hazards using the methodology discussed in Item 1 above, and (2) identify actions that have been taken, or are planned, to address plant-specific issues associated with the updated natural external hazards (including potential changes to the licensing or design basis of a plant).</p> <p>3. Evaluate licensee responses and take appropriate regulatory action to resolve issues associated with updated site-specific natural external hazards.</p>				
7	<p>SFP Makeup Capability (NTTF 7.2, 7.3, 7.4, and 7.5) (NTTF Recommendations)</p> <p>7.2 Order licensees to provide safety-related ac electrical power for the spent fuel pool makeup system.</p>	No Action	NA	NA	
	<p>7.3 Order licensees to revise their technical specifications to address requirements to have one train of onsite emergency electrical power operable for spent fuel pool makeup and spent fuel pool instrumentation when there is irradiated fuel in the spent fuel pool, regardless of the operational mode of the reactor.</p>	No Action	NA	NA	

Table 4-1 Post-Fukushima NRC Recommendations and Requirements (14 of 18)

NTTF Rec. No	NRC Recommendations/Requirements in SECY-11-0093, SECY-11-0137, SECY-12-0025, SECY-12-0095, EA-12-049, EA-12-051	APR1400 Design	Applicable DCD Section	COL Action	Note
	7.4 Order licensees to have an installed seismically qualified means to spray water into the spent fuel pools, including an easily accessible connection to supply the water (e.g., using a portable pump or pumper truck) at grade outside the building.	No Action	NA	NA	
	7.5 Initiate rulemaking or licensing activities or both to require the actions related to the spent fuel pool described in detailed recommendations 7.1–7.4.	No Action	NA	NA	
9.3	<p>Emergency preparedness regulatory actions (the remaining portions of Recommendation 9.3, with the exception of Emergency Response Data System (ERDS) capability addressed in Tier 3)</p> <ol style="list-style-type: none"> 1. Engage stakeholders to inform the development of acceptance criteria for the licensee examination of planning standard elements related to the recommendations, and 2. Develop and issue an order to address those changes necessary in emergency plans to ensure adequate response to SBO and multiunit events specific to (1) adding guidance to the emergency plan that documents how to perform a multiunit dose assessment, (2) conduct periodic training and exercises for multiunit and prolonged SBO scenarios, (3) practice (simulate) the identification and acquisition of offsite resources, to the extent possible, and (4) ensure that EP equipment and facilities are sufficient for dealing with multiunit and prolonged SBO scenarios. 	No Action	NA	NA	

Table 4-1 Post-Fukushima NRC Recommendations and Requirements (15 of 18)

NTTF Rec. No	NRC Recommendations/Requirements in SECY-11-0093, SECY-11-0137, SECY-12-0025, SECY-12-0095, EA-12-049, EA-12-051	APR1400 Design	Applicable DCD Section	COL Action	Note
Tier 3 (Those NTTF Recommendations that require further staff study to support a regulatory action)					
2.2	<p>Ten-year confirmation of seismic and flooding hazards (dependent on Recommendation 2.1) Initiate rulemaking to require licensees to confirm seismic hazards and flooding hazards every 10 years and address any new and significant information. If necessary, update the design basis for SSCs important to safety to protect against the updated hazards.</p>	No Action	NA	NA	
3	<p>Potential enhancements to the capability to prevent or mitigate seismically-induced fires and floods (long-term evaluation) The Task Force recommends, as part of the longer term review, that the NRC evaluate potential enhancements to the capability to prevent or mitigate seismically induced fires and floods.</p>	No Action	NA	NA	
5.2	<p>Reliable hardened vents for other containment designs (long-term evaluation) Reevaluate the need for hardened vents for other containment designs, considering the insights from the Fukushima accident. Depending on the outcome of the reevaluation, appropriate regulatory action should be taken for any containment designs requiring hardened vents.</p>	No Action	NA	NA	
6	<p>Hydrogen control and mitigation inside containment or in other buildings (long-term evaluation) The Task Force recommends, as part of the longer term review, that the NRC identify insights about hydrogen control and mitigation inside containment or in other buildings as additional information is revealed through further study of the Fukushima Dai-ichi accident.</p>	No Action	NA	NA	

Table 4-1 Post-Fukushima NRC Recommendations and Requirements (16 of 18)

NTTF Rec. No	NRC Recommendations/Requirements in SECY-11-0093, SECY-11-0137, SECY-12-0025, SECY-12-0095, EA-12-049, EA-12-051	APR1400 Design	Applicable DCD Section	COL Action	Note
9.1 & 9.2	<p>Emergency preparedness (EP) enhancements for prolonged SBO and multiunit events (dependent on availability of critical skill sets)</p> <p>9.1 Initiate rulemaking to require EP enhancements for multiunit events in the following areas:</p> <ul style="list-style-type: none"> • personnel and staffing • dose assessment capability • training and exercises • equipment and facilities <p>9.1 Initiate rulemaking to require EP enhancements for prolonged SBO in the following areas:</p> <ul style="list-style-type: none"> • communications capability • ERDS capability • training and exercises • equipment and facilities 	No Action	NA	NA	
9.3	<p>ERDS capability (related to long-term evaluation Recommendation 10)</p> <p>Order licensees to do the following until rulemaking is complete:</p> <ul style="list-style-type: none"> • Maintain ERDS capability throughout the accident. 	No Action	NA	NA	
10	<p>Additional EP topics for prolonged SBO and multiunit events (long-term evaluation)</p> <p>10.1 Analyze current protective equipment requirements for emergency responders and guidance based upon insights from the accident at Fukushima.</p> <p>10.2 Evaluate the command and control structure and the qualifications of decision-makers to ensure that the proper level of authority and oversight</p>	No Action	NA	NA	

Table 4-1 Post-Fukushima NRC Recommendations and Requirements (17 of 18)

NTTF Rec. No	NRC Recommendations/Requirements in SECY-11-0093, SECY-11-0137, SECY-12-0025, SECY-12-0095, EA-12-049, EA-12-051	APR1400 Design	Applicable DCD Section	COL Action	Note
	<p>exists in the correct facility for a long-term SBO or multiunit accident or both.</p> <ul style="list-style-type: none"> • Concepts such as whether decision-making authority is in the correct location (i.e., at the facility), whether currently licensed operators need to be integral to the ERO outside of the control room (i.e., in the TSC), and whether licensee emergency directors should have a formal “license” qualification for severe accident management. <p>10.3 Evaluate ERDS to do the following:</p> <ul style="list-style-type: none"> • Determine an alternate method (e.g., via satellite) to transmit ERDS data that does not rely on hardwired infrastructure that could be unavailable during a severe natural disaster. • Determine whether the data set currently being received from each site is sufficient for modern assessment needs. • Determine whether ERDS should be required to transmit continuously so that no operator action is needed during an emergency. 				
11	<p>EP topics for decision-making, radiation monitoring, and public education (long-term evaluation)</p> <p>11.1 Study whether enhanced onsite emergency response resources are necessary to support the effective implementation of the licensees’</p>	No Action	NA	NA	

Table 4-1 Post-Fukushima NRC Recommendations and Requirements (18 of 18)

NTTF Rec. No	NRC Recommendations/Requirements in SECY-11-0093, SECY-11-0137, SECY-12-0025, SECY-12-0095, EA-12-049, EA-12-051	APR1400 Design	Applicable DCD Section	COL Action	Note
	<p>emergency plans, including the ability to deliver the equipment to the site under conditions involving significant natural events where degradation of offsite infrastructure or competing priorities for response resources could delay or prevent the arrival of offsite aid.</p> <p>11.2 Work with FEMA, States, and other external stakeholders to evaluate insights from the implementation of EP at Fukushima to identify potential enhancements to the U.S. decision-making framework, including the concepts of recovery and reentry.</p> <p>11.3 Study the efficacy of real-time radiation monitoring onsite and within the EPZs (including consideration of ac independence and real-time availability on the Internet).</p> <p>11.4 Conduct training, in coordination with the appropriate Federal partners, on radiation, radiation safety, and the appropriate use of KI in the local community around each nuclear power plant.</p>				
12.1	<p>Reactor Oversight Process modifications to reflect the recommended defense-in-depth framework (dependent on Recommendation 1) Expand the scope of the annual reactor oversight process (ROP) self-assessment and biennial ROP realignment to more fully include defense-in-depth considerations.</p>	No Action	NA	NA	
12.2	<p>Staff Training on Severe Accidents and Resident Inspector Training on SAMGs (dependent on Recommendation 8) Enhance NRC staff training on severe accidents, including training resident inspectors on SAMGs.</p>	No Action	NA	NA	

5.0 STRATEGIES TO ACTION ITEMS FROM FUKUSHIMA DAI-ICHI EVENTS

5.1 Tier 1 Items

5.1.1 Recommendation 2.1 – Seismic and Flooding Re-Evaluation

Seismic and flooding re-evaluation is the responsibility of COL applicant. The COL applicant will confirm that the site-specific design criteria for seismic and flood are met. It is expected that the APR1400 will satisfy the seismic requirements since it is designed to meet Central and Eastern United States (CEUS) seismic requirements. Also, for dry sites, the APR1400 will not have a problem in regard to flooding. However, for wet sites, flood protection may be necessary depending on the location of FLEX equipment. Therefore, the COL applicant will also address the flood requirements for wet sites.

5.1.2 Recommendations 4.1 and 4.2 – SBO and FLEX

5.1.2.1 Introduction

This subsection summarizes the APR1400 diverse and flexible coping (FLEX) strategies for the beyond-design-basis external event (BDBEE), extended loss of all ac power (ELAP) concurrent with loss of normal access to ultimate heat sink (LUHS). The purpose of establishing the FLEX strategies is to maintain core cooling, spent fuel pool (SFP) cooling, and to ensure containment functions and structural integrity through containment cooling.

The core cooling safety function includes maintaining core cooling, reactor coolant system (RCS) inventory, RCS boration, and key reactor instrumentation. The containment cooling safety function includes maintaining containment pressure control, and key containment instrumentation. The SFP cooling safety function includes maintaining SFP cooling and key SFP instrumentation.

NTTF Recommendation 4 (Reference 1) recommends that all operating and new reactor designs enhance SBO mitigation capability for BDBEEs. Recommendation 4.1 outlines minimum coping times for SBO events. Recommendation 4.2 recommends that licensees provide reasonable protection from BDBEEs and add any additional equipment necessary to address multiunit events. This report addresses both Recommendation 4.1 and 4.2 through the baseline coping strategies.

5.1.2.2 Baseline Coping Capability

The guidance for developing, implementing, and maintaining mitigation strategies from JLD-ISG-2012-01 (Reference 7) and the methodology to establish baseline coping capability from NEI 12-06 (Reference 8) were considered in developing the APR1400 FLEX strategies and evaluating the resultant baseline coping capability after the BDBEE.

The APR1400 FLEX strategies follow a three-phase approach as required in the Order EA-12-049 (Reference 5). The three phases are:

- Phase 1 – Initial response phase using installed equipment
- Phase 2 – Transition phase using FLEX equipment and consumables
- Phase 3 – Indefinite sustainment of these functions using offsite resources.

The APR1400 baseline coping capability to maintain core cooling, SFP cooling, and containment cooling after the BDBEE are addressed in the following sections, along with the FLEX strategies and supporting analyses.

5.1.2.3 Operational Strategy for Core Cooling

The APR1400 core cooling capability to cope with the BDBEE, ELAP concurrent with LUHS, is addressed for all of the following operation modes.

- a. Full-power operation
- b. Low-power operations and shutdown conditions with steam generators (SGs) available
- c. Shutdown conditions with SGs not available

5.1.2.3.1 FLEX Strategy for Full-Power Operation

The initiating event is assumed to be a loss of offsite power (LOOP) with concurrent loss of all ac power and LUHS during full-power operation. Based on the analysis performed, the APR1400 design includes consideration of the following event sequence to address FLEX strategy for full-power operation:

Phase 1: 0 to 8 hours

Phase 2: 8 to 72 hours

Phase 3: Indefinite time period following Phase 2

The timeline of the APR1400 FLEX strategy for full-power operation is shown in Figure 5-1 and the detailed sequence of events is tabulated in Table 5-1. The following are the operational strategies for each phase.

5.1.2.3.1.1 Phase 1: Coping with Installed Plant Equipment (0 to 8 hours)

5.1.2.3.1.1.1 Phase 1-a: 0 to 1 hour

The main control room (MCR) operators may require up to 1 hour to assess plant conditions, equipment and system availability, and to identify the event as an ELAP concurrent with LUHS.

During Phase 1-a, only the installed plant equipment is used for coping. Specifically, two turbine-driven auxiliary feedwater pumps (TDAFWPs) automatically start on an auxiliary feedwater actuation system (AFAS) signal to provide core cooling through the SGs. Auxiliary feedwater storage tanks (AFWSTs) are used to supply water to the TDAFWPs, and steam generated in the SGs is released through the main steam safety valves (MSSVs). Class 1E batteries supply dc power to essential instrumentation and control (I&C) equipment, and for the operation of the TDAFWPs. The RCS is maintained at hot standby condition by the natural circulation cooling (NCC) operation without any operator action during this phase.

The reactor coolant pump (RCP) seal integrity may be challenged, because both the seal injection water supply and component cooling water supply to the RCP thermal barrier heat exchanger are lost due to the event of ELAP concurrent with LUHS. The RCP seal leakage is assumed to be 94.64 L/min (25 gpm) per RCP, based on the evaluation report on the APR1400 KSB RCP seals (Reference 9).

5.1.2.3.1.1.2 Phase 1-b (1 to 8 hours)

Throughout Phase 1, the RCS can be maintained at hot standby condition by the NCC operation without any operator action. The TDAFWPs are powered from the Class 1E batteries in Trains C/D for 16 hours without load shedding, and up to 40 hours with load shedding started at 8 hours. The AFWSTs supply

water to the TDAFWPs for core cooling and steam generated in the SGs is released through the MSSVs. The total volume of water required from the AFWSTs during this phase is approximately 529.96 m³ (140,000 gal), which is much lower than the capacity of AFWSTs (See Table 5-2). The passive components, MSSVs, are operable without electrical power. Based on the analysis, the water level in the core is found to be well above the top of the active core during this phase, even though the RCP seal leakage is assumed to occur from the beginning of the event. During this phase, additional cooling in MCR, electrical and I&C equipment rooms, and the TDAFWP rooms is found not to be required based on heatup calculations. The maximum temperature of each room is guaranteed not to exceed the allowable values in table below to assure operability of equipment. As a result, Phase 1 coping time for this event can be extended to more than 16 hours. The COL applicant is to assure the survivability of the equipment

Room	Maximum Allowable Temperature
MCR	110°F
TDAFWP Rooms ¹⁾	150°F
Electrical and I&C equipment rooms	120°F

1) The operability of equipment and instruments is guaranteed until 16hours after loss of HVAC.

In the meantime, the operator prepares for the next phase as soon as diagnosis of the event is complete: operator tries to connect the 480 V mobile gas turbine generator (GTG) to the 480 V Class 1E power system Train A or B, and a primary high-head FLEX pump to the safety injection system (SIS) for RCS inventory makeup. Two secondary FLEX pumps are also connected to the SG auxiliary feedwater (AFW) supply lines, one for each AFW line. The operator action is assumed to be finished within 8 hours following the event. Because the Phase 1 coping time can be extended to more than 16 hours, the operator has sufficient additional time margin to prepare for Phase 2, even though the period of Phase 1 is assumed to be 8 hours in the core cooling strategy.

5.1.2.3.1.2 Phase 2: Coping with Installed Plant Equipment and Onsite Portable Resources (8 to 72 hours)

As soon as preparation for Phase 2 is finished, the operator starts to cool down the RCS to a safe shutdown state, i.e., hot shutdown or cold shutdown (see Figure 5-1), using the installed plant equipment and/or the onsite FLEX equipment.

During Phase 2, two types of core cooling strategies can be applied:

- a. Basic operational strategy using installed plant equipment such as TDAFWP and the auxiliary charging pump (ACP), and FLEX equipment such as 480 V mobile GTG
- b. Contingency plan using only the onsite FLEX equipment, which is applied if the installed plant equipment is not operable

Each of these strategies is described below.

5.1.2.3.1.2.1 Basic Operational Strategy

In the basic operational strategy, the RCS is cooled down to and maintained at the hot shutdown (176.67 °C [350 °F]) using both of installed plant equipment such as TDAFWP and ACP, and the FLEX equipment such as 480 V mobile GTG.

The RCS is cooled down to the hot shutdown condition by feed-and-bleed operation through the secondary side of SG using the TDAFWPs and main steam atmospheric dump valves (MSADVs). The

AFWSTs with backup water source from the raw water tank (RWT) continue to supply water to the SGs using the TDAFWP, while each SG level is maintained between 25 to 40 percent wide range by on-off control of the auxiliary feedwater isolation valves.

Two 480 V, 1,000 kW, mobile GTGs are provided to meet N+1 requirement. One of the 480 V mobile GTGs is connected to the 480 V Class 1E power system Train A or B, and supplies power to the 125 Vdc battery charger, the 480 V load center, and the motor control center (MCC). With this Class 1E power, ACP, MSADVs, and essential I&C equipment are available during this phase. During this phase, additional cooling in MCR, electrical and I&C equipment rooms, and ACP room is not required based on heatup calculations. The maximum temperature of each room is guaranteed not to exceed the allowable values in table below to assure operability of equipment. The COL applicant is to assure the survivability of the equipment

Room	Maximum Allowable Temperature
MCR	110°F
ACP Rooms	150°F
Electrical and I&C equipment rooms	120°F

ACP is used to provide makeup water for maintaining RCS inventory and provide RCP seal cooling. The suction source for ACP is the boric acid storage tank (BAST) and in-containment refueling water storage tank (IRWST). The water volume required for RCS inventory makeup during Phase 2 is approximately 643.52 m³ (170,000 gal).

5.1.2.3.1.2.2 Contingency Plan

In the contingency plan strategy, installed plant equipment is assumed to be inoperable even after connection of 480 V mobile GTG. In this case, the RCS is further cooled down to around 110 °C (230 °F) with SGs fed by the two secondary side FLEX pumps instead of the plant installed TDAFWPs. RCS makeup is carried out by a primary side high-head FLEX pump instead of an ACP.

If the installed plant equipment, ACP, is inoperable, RCS inventory makeup can be provided by a primary side high-head FLEX pump 189.27 L/min (50 gpm) positive displacement pump with operating pressure of 105.46 kg/cm²A (1,500 psia).

Two secondary FLEX pumps are also connected to the SG auxiliary feedwater (AFW) supply lines: one for each AFW line. The secondary FLEX pumps can be used to supply feedwater to SGs, when TDAFWPs are unavailable. If the SG pressure is under 6.33 kg/cm²A (90 psia) during this phase, the TDAFWPs are inoperable. In this case, RCS is further cooled down to around 110 °C (230 °F) by depressurizing the SG to 1.03 kg/cm²A (14.7 psia) using the MSADVs. During this time, the SG inventory is provided by the secondary side FLEX pumps (total dynamic head [TDH] of 17.01 kg/cm²A [242 psia] at the rated flow rate of 1,173.48 L/min [310 gpm]) with suction from AFWST and RWT. The N+1 requirement for FLEX equipment is met by deploying two primary high-head FLEX pumps and three secondary FLEX pumps on site.

Additionally, as RCS cooldown continues and RCS pressure decreases to the designed setpoint of safety injection tank (SIT) injection, the SITs automatically discharge 4,000 ppm borated water into the RCS for boration and inventory makeup.

5.1.2.3.1.2.3 Common Strategy to Both the Basic Strategy and Contingency Plan

As the TDAFWPs or the secondary FLEX pumps continue to feed the SG, the AFWST inventory is depleted. Then, the suction of the TDAFWPs is realigned to the RWTs. The fuel for the mobile GTG is supplied by gravity flow from the emergency diesel generator (EDG) fuel oil day tank(s). Once the mobile GTG is running, the existing diesel fuel oil transfer pump is used to make up day tanks from the underground EDG fuel oil storage tanks, each having a capacity of 7 days of EDG operation at its continuous rating. Connections are also provided to supply fuel from the EDG fuel oil day tank to the primary and secondary side FLEX pumps for operation during Phase 2.

Table 5-2 shows the water volumes available from the AFWST and RWT during Phase 2. Although the water source from the RWT should be shared with SFP cooling, the AFWST and RWT are evaluated to be sufficient for continuous NCC operation for up to 11 days (see Table B-3 in Appendix B).

After the plant is brought to the safe shutdown state, i.e., hot shutdown or cold shutdown, the 4.16 kV mobile GTG and other resources, such as cooling water and fuel, will also be prepared by the end of Phase 2. All of the operator actions to prepare Phase 3 will be finished by 72 hours following the event. Even though Phase 2 is assumed to last until 72 hours in this core cooling strategy, the capacity of the onsite SG cooling, RCS makeup water, and GTG fuel sources show the duration of Phase 2 can be extended up to 11 days. Hence, the operator has sufficient time margin to prepare for Phase 3.

The specific storage location, mobilization, and other details for the FLEX pumps and mobile GTGs are COL items.

5.1.2.3.1.3 Phase 3: Coping with both Installed and Offsite Resources in Addition to the Onsite Equipment (after 72 hours)

In Phase 3, offsite resources including a 4.16 kV mobile GTG, fuel, and cooling water can be assumed to be available for long-term coping with the BDBEE. The 4.16 kV mobile GTG is used to restore Train A or B of 4.16 kV Class 1E power system. The plant is brought to cold shutdown, using the shutdown cooling system (SCS) if the ultimate heat sink (UHS) is available after 4.16 kV Class 1E power is restored. If not, the plant is maintained at the same safe shutdown state as in Phase 2.

In this case, the primary and secondary makeup water sources and fuel oil for the mobile GTGs are refilled from offsite resources. The details for the offsite resources will be provided by the COL applicant.

5.1.2.3.2 FLEX Strategy for Low-Power and Shutdown Operation with SGs Available

5.1.2.3.2.1 Strategy for Mode 1 through Mode 3

The NCC analysis result for the full-power FLEX strategy is still valid for operation in modes 1 through 3, i.e., lower-power operation, startup, and hot standby conditions, because it covers various states of the plant, including full-power operation through hot shutdown condition. Therefore, the same FLEX strategy as in the full-power operation can be also applied to the Mode 1 through Mode 3 operations.

5.1.2.3.2.2 Strategy for Mode 4 and Mode 5 with SGs Available

In these operation modes, the SCS normally maintains the RCS between 176.67 °C (350 °F) (hot shutdown) and 54.44 °C (130 °F) (cold shutdown), while the SGs are still available.

If the event an ELAP concurrent with LUHS occurs during these operation modes, the RCS is heated up

and pressurized due to the loss of the SCS.

If the RCS temperature is initially below the maximum RCS temperature requiring low-temperature overpressurization protection (LTOP), i.e., 136.11 °C (277 °F), the RCS pressure can be maintained below the LTOP protection limiting pressure of 43.94 kg/cm²A (625 psia) (20 percent of the RCS hydraulic test pressure of 219.71 kg/cm²A [3,125 psia]), because the LTOP relief valve installed in the SCS automatically opens at the opening setpoint (38.51 kg/cm²A [530 psig]). After the RCS temperature increases to the LTOP disable temperature (136.11 °C [277 °F]), the operator tries to isolate the RCS from the SCS by manually closing the SCS isolation valves. The operator action for the isolation of the SCS is finished before the RCS temperature exceeds the SCS entry temperature 176.67 °C (350 °F). After that, the RCS overpressurization can be protected by pilot-operated safety relief valves (POSRVs).

After closing of the SCS isolation valves, the RCS temperature and pressure continue to increase, and eventually return to the hot standby condition. Then, the SG side feed-and-bleed operation can start cooling down the RCS, as described in the baseline cooling capability for ELAP and LUHS at full-power operation. Consequently, the full-power FLEX strategy can be also applied after the plant returns to hot standby condition.

5.1.2.3.3 FLEX Strategy for Shutdown Operation with SGs Not Available

The APR1400 shutdown operations with SGs not available include the mode 5 reduced inventory operation and the mode 6 refueling operation. If the ELAP concurrent with LUHS occurs during the reduced inventory operation or refueling, decay heat can be removed from the core by the RCS feed-and-bleed operation.

The APR1400 FLEX strategy follows a three-phase approach as required in Order EA-12-049 (Reference 5). The following sections are general descriptions of FLEX strategy for shutdown operation with SGs not available. Detailed procedures will be developed by the COL applicant. The APR1400 added a COL item in DCD Chapter 19.3 specifying that the COL applicant will develop shutdown risk processes and procedures, and verify the ability to deploy FLEX equipment to provide core cooling in shutdown operations with SGs not available.

5.1.2.3.3.1 Phase 1: Coping with Installed Plant Equipment

During Phase 1, decay heat is removed by the latent heat resulting from water boiloff in the core. The APR1400 will take actions to proceduralize administrative controls to pre-stage FLEX equipment prior to entering a condition where the SGs cannot provide adequate cooling.

5.1.2.3.3.2 Phase 2: Coping with Installed Plant Equipment and Onsite Portable Resources

In Phase 2, the plant can be maintained at cold shutdown by the RCS feed-and-bleed operation using the FLEX pump which is connected to the SIS injection line. The RCS inventory makeup is carried out by external injection using the primary side low-head FLEX pump with rated flow of 2,839.06 L/min (750 gpm), which is sufficient capacity for removing decay heat and flushing the RCS. Prior to core uncover, the primary side low-head FLEX pump must be aligned to take suction from the acceptable coolant source and deliver the coolant to the vessel. A mobile GTG is prepared to connect to Train A or Train B 480 V Class 1E ac power system to supply power to Class 1E battery.

Two primary low-head FLEX pumps are provided to meet the N+1 requirement.

The specific storage location, mobilization, and other details for the FLEX pumps and mobile GTGs are COL items.

5.1.2.3.3 Phase 3: Coping with Both Installed Plant Equipment and Offsite Resources in Addition to Onsite Equipment

In Phase 3, the 4.16 kV mobile GTG, fuel, and cooling water are available from offsite for long-term coping for the event. The 4.16 kV mobile GTG is used to restore Train A or Train B of 4.16 kV Class 1E power system. If the SCS is operable when the 4.16 kV Class 1E power is restored, the plant is cooled down to and maintained at cold shutdown by resuming the SCS operation. If not, the operator keeps the plant at the same safe shutdown state as in Phase 2, using the primary FLEX pump for RCS inventory makeup. The primary makeup water source and fuel oil for the mobile GTGs are refilled using offsite resources. Details for the offsite resources will be provided by the COL applicant.

5.1.2.3.4 Supporting Analysis for Core Cooling

Supporting analyses have been performed using RELAP5/Mod 3.3 to confirm the APR1400 core cooling capability to cope with the BDBEE, ELAP concurrent with LUHS, according to the FLEX strategies.

5.1.2.3.4.1 Acceptance Criteria

The following acceptance criteria based on the NEI 12-06, Section 3.2.1 (Reference 8) are applied to the supporting analysis for the operational strategy for core cooling during the BDBEE:

- Core cooling is maintained.
- No fuel failures occur.

The fulfillment of above criteria is determined by evaluating RCS key parameters, such as RCS and SG pressures, RCS temperature, and collapsed levels in the reactor vessel, core, and SG.

5.1.2.3.4.2 Analysis Conditions

The following analysis conditions and assumptions are selected according to the requirements of NEI 12-06, Section 3.2.1.

- The plant is assumed to operate at 100 percent rated power with no uncertainty for system parameters.
- The initiating event is assumed to be ELAP concurrent with LUHS.
- The reactor is assumed to be tripped automatically by the low RCP speed trip function of the RPS since the RCPs could not be provided with ac power.
- The MSSVs are assumed to actuate automatically when the SG pressure exceeds the MSSV setpoints.
- RCP seal leakage is assumed to be 94.64 L/min (25 gpm) per RCP. This causes loss of RCS inventory, which should be adequately compensated for preventing core uncover.
- The TDAFWPs are assumed to start automatically on receipt of an AFAS signal.
- The decay heat conditions of ANSI/ANS-5.1-1979 are used for best-estimate simulation of the

FLEX strategy.

- The operator is assumed to cool down the RCS by controlling MSADVs with a rate of 27.78 °C/hr (50 °F/hr) from 8 hours following the BDBEE.
- The auxiliary charging pump (ACP) is assumed to supply borated water at the constant value of 166.56 L/min (44 gpm) for RCS makeup after 8 hours following the event. If the ACP is unavailable for supplying water to RCS, a primary high-head FLEX pump is used for providing adequate water for maintaining RCS inventory.
- Four SITs inject 4,000 ppm borated water into RCS when RCS pressure decreases below the setpoints as designed.
- Normal feedwater flow to the SGs is assumed to stop at the initiation of the BDBEE. Auxiliary feedwater flow supplies water to the SGs and is controlled to maintain SG level within the control band of 25 to 40 percent.

5.1.2.3.4.3 Analysis Results and Conclusion

The APR1400 core cooling capability under the BDBEE, ELAP concurrent with LUHS, is analyzed using the RELAP5/Mod 3.3 code, according to the full-power operational strategy, consisting of the following three phases as described in Subsection 5.1.2.3.1.

- Phase 1: 0 to 8 hours
- Phase 2: 8 to 72 hours
- Phase 3: Indefinite time period following Phase 2

For the full-power operation case, two types of core cooling strategies, which are basic operational strategy and contingency plan, are analyzed. In the basic strategy, the RCS is cooled down to hot shutdown using both installed plant equipment (such as MSADV, TDAFWP, and ACP), and FLEX equipment (such as the mobile GTG). The contingency plan is prepared in case the installed plant equipment is inoperable even after connection of mobile ac power. In this case, the RCS is cooled down to cold shutdown using the secondary side FLEX pump. RCS makeup is carried out by the primary side high-head FLEX pump.

Based on the two types of cooling strategies employed, it is concluded that the plant can be maintained at hot standby condition during Phase 1 (0 to 8 hours following the BDBEE), and cooled down to hot shutdown or cold shutdown state during Phase 2 (8 to 72 hours), using onsite resources. The same safe shutdown state is also be maintained during Phase 3 (after 72 hours), by continuing NCC operation with the cooling water source (for FLEX pumps) and fuel oil (for mobile GTGs) supplied from offsite resources.

If SCS is successfully restored after the 4.16 kV GTG is connected, the plant can be brought to and maintained at cold shutdown using the SCS instead of SG cooling.

Appendix A provides further details of these analyses for the operational strategies – basic operational strategy and contingency plan – in the aspect of core cooling capability during this event.

Appendix A also shows the APR1400 coping capability against ELAP concurrent with LUHS during low-power operations and shutdown conditions. Based on the evaluation results for the operation modes 1 through 4 with SGs available, the aforementioned full-power operation strategy is still valid for this

condition.

In the operation modes 4 and 5 with SGs available, the SCS normally maintains the RCS between 176.67 °C (350 °F) (hot shutdown) and 54.44 °C (130 °F) (cold shutdown), while the SGs are still available. If the ELAP concurrent with LUHS occurs during these operation modes, the RCS is heated up and pressurized for a period due to the loss of the SCS. If the RCS temperature is initially below the maximum RCS temperature requiring the LTOP, i.e., 136.11 °C (277 °F), the RCS pressure can be maintained below the LTOP limiting pressure of 43.94 kg/cm²A (625 psia), because the LTOP relief valve installed in the SCS automatically opens at the opening setpoint (38.51 kg/cm²A [530 psig]). Once the RCS temperature reaches the LTOP disable temperature (136.11 °C [277 °F]), the operator isolates the RCS from the SCS by manually closing the SCS isolation valves. The operator action for isolation of the SCS is finished before the RCS temperature exceeds the SCS entry temperature (176.67 °C [350 °F]). After that, the RCS overpressurization can be protected by POSRVs. After closing the SCS isolation valves, the RCS temperature and pressure continue to increase, and eventually return to the hot standby condition. The full-power FLEX strategy can be also applied after the plant returns to hot standby.

The specific storage location, mobilization, and other details for the FLEX pumps and mobile GTGs are COL items.

5.1.2.4 SFP Cooling

This subsection outlines the operational strategy to maintain the SFP water level at a safe condition throughout the BDBEE. The APR1400 SFP conditions are analyzed for a number of postulated scenarios for the ELAP event. The scenario with ELAP following a seismic event is found to be the most limiting case due to the higher SFP inventory loss.

5.1.2.4.1 Strategy for SFP Cooling

Based on the supporting analyses (see Subsection 5.1.2.4.2) to determine the bulk SFP heatup time and boiloff rate, for a worst-case full core offload, these analyses concluded the following:

- The operators have approximately 26.6 hours to restore cooling and/or makeup to the SFP in order to keep the spent fuel covered. Therefore, boiling of the SFP can be credited as the Phase 1 event mitigation method.
- To maintain at least 3.05 m (10 ft) of water inventory over the fuel assemblies, makeup water to the SFP is provided within 15.36 hours.
- For Phases 2 and 3 of event mitigation, an SFP makeup rate of 493.2 L/min (130.3 gpm) is needed to match the initial boiloff rate. The boiloff rate decreases over time as the spent fuel decay heat decreases.

Based on this information, an overview of the spent fuel cooling mitigation strategies is provided in Table 5-4. Specific details of the SFP mitigation strategies for each phase are provided in the following subsections.

5.1.2.4.1.1 Phase 1: SFP Cooling (0 to 8 hours)

In Phase 1, action is taken to open the rollup door to the fuel handling area truck bay on the EI. 100'-0" of the auxiliary building, prior to the onset of boiling, to establish a vent path from the area for steam generated from the SFP. Based on the analyses, SFP boiling is calculated to occur no sooner than 2.0 hours after the ELAP event occurs, considering the most limiting plant condition, i.e., mode 6 with full core

offload and failure of non-seismic Category I piping.

No makeup water to the SFP is required and the water level is monitored. During this phase, a FLEX pump with external makeup water connections to the RWT is established.

The vent path for the spent fuel area that is established in Phase 1 is maintained open in Phases 2 and 3.

5.1.2.4.1.2 Phase 2: SFP Cooling (8 to 72 hours)

For Phase 2 event mitigation, makeup is required to the SFP. Based on the analyses presented in Appendix B, a minimum flow rate of 493.2 L/min (130.3 gpm) is required to match the worst-case SFP boiloff rate. This SFP makeup flow requirement is bounded, however, by the SFP makeup flow requirement needed to mitigate the effect of loss of large area (LOLA) per 10 CFR 50.54(hh) (2). The self-powered (diesel-driven) FLEX, 1,893 L/min (500 gpm) and 757 L/min (200 gpm), SFP makeup pump and spray pump relied on to mitigate LOLA are therefore credited to mitigate the BDBEE. These pumps are provided to meet the N+1 requirement for a single-unit site and will meet 10 CFR 50 Appendix A, General Design Criterion (GDC) 2.

SFP Makeup Water Source

In all operating modes, the raw water tank (RWT) can be used as the water source for SFP makeup. The RWT contains sufficient water inventory for SFP makeup required for mode 6 operation (limiting), which is 1,676 m³ (442,883 gal) as shown in Appendix B, Table B-3.

Flexible hoses, FLEX pump(s), fuel for FLEX pump(s), and any other equipment required for this strategy are normally located away from the auxiliary building (i.e., greater than 91.44 m [100 yards]), so that mobilization of the equipment for SFP makeup capability can occur within the most limiting time of 15.03 hours for mode 6 operation (boiloff time to 3.05 m [10 ft] above fuel rack top water level).

Makeup Water FLEX Pump Staging and Pump Discharge Connections

In Phase 2, the FLEX pump described above is staged outside the auxiliary building.

The FLEX pump discharge hose is routed to one of the two permanent SFP makeup connections located outside the east wall of the auxiliary building, as shown in Figure 6-2. One primary connection location is mounted on the wall of auxiliary building adjacent to, and just south of, the emergency diesel generator (EDG) building, and the other connection is mounted on the wall of auxiliary building adjacent to, and just north of, the emergency diesel generator building. The alternate connection is close to the SFP makeup connections. An SFP spray connection is close to each SFP makeup connection.

Standpipes to SFP Area

The FLEX pump connections are each connected to an independent, seismically qualified standpipe that runs inside the auxiliary building from the pump staging area to a location above the SFP at El. 156 ft. The two standpipes for the SFP makeup pump and the two standpipes for the SFP spray pump are located at diverse locations in the auxiliary building and extend from the ground elevation to the SFP elevation. The standpipes are suitably separated on the same side of the auxiliary building. The standpipes have connections at the bottom at ground elevation and the connections are external to the auxiliary building. Operators are able to connect flexible hoses to the standpipes, which are supplied by a FLEX pump. The standpipes for SFP makeup have hard-piped connections to the SFP edge to allow water makeup to the pool. The standpipes for SFP spray have hard-piped connections to the spray headers to allow spray into the pool. Each spray header is equipped with a number of spray nozzles to

direct flow into SFP area. An isolation valve and a check valve are provided on each standpipe.

The simplified arrangements of these makeup and spray provisions are shown in Figures 6-2 and 6-3.

SFP Makeup FLEX Pumps

The diesel-driven FLEX pumps are provided to supply SFP makeup and SFP spray at a rate of at least 1,893 L/min (500 gpm) and 757 L/min (200 gpm) at discharge pressure heads of 32 m (105 ft) and 32.6 m (107 ft), respectively.

FLEX Equipment Storage

The flexible hoses, FLEX pump, FLEX pump fuel supply, and any other FLEX equipment required for this strategy are stored away from the auxiliary building (i.e., greater than 91.44 m [100 yards] away) so that mobilization of the equipment for SFP makeup capability can occur within the 15.36-hour period identified above. The specific storage location, mobilization, and other details for the FLEX equipment are COL items.

5.1.2.4.1.3 Phase 3: SFP Cooling (after 72 hours)

The APR1400 continues operating with Phase 2 strategies to provide makeup to the SFP in Phase 3. In Phase 3, makeup to the RWT is provided from offsite water sources by the COL applicant.

5.1.2.4.2 Supporting Analyses for the Operational Strategy for SFP Cooling

SFP decay heat removal capacity has been evaluated to confirm that SFP cooling can be continued during and after the occurrence of a BDBEE resulting in an ELAP and LUHS.

5.1.2.4.2.1 Evaluation Conditions

NEI 12-06, Section 3.2.1.6 defines the following SFP conditions as general criteria and baseline assumptions for SFP conditions:

- All boundaries of the SFP are intact, including the liner, gates, transfer canals, etc.
- Although sloshing may occur during a seismic event, the initial loss of SFP inventory does not preclude access to the refueling deck around the pool.
- SFP cooling system is lost.
- SFP heat load assumes the maximum design basis heat load as defined in Appendix B.
- Initial SFP water level is assumed at El. 149 ft 0 in (elevation of SFP cleanup suction nozzle).
- SFP inventory makeup starts when the water level reaches Level 2 defined in NEI 12-02 (Reference 12).
- Water inventories:

The water inventory above top of fuel rack: 816.3 m³ (28,826 ft³)

Total SFP inventory: 816.3 m³ (28,826 ft³)

5.1.2.4.2.2 Evaluation Results

From the detailed analysis presented in Appendix B, Table B-1, it can be seen that the worst-case SFP cooling load occurs in mode 6 with a full core offload.

5.1.2.4.2.3 Conclusions

Based on the SFP time to boil and makeup analysis provided above and in Appendix B, considering a worst-case full core offload, the conclusions are as follows:

- The operators have approximately 29.6 hours to restore cooling and/or makeup to the SFP in order to keep the spent fuel covered. Therefore, boiling of the SFP can be credited as the Phase 1 event mitigation method.
- To maintain at least 3.05 m (10 ft) of water inventory over the fuel assemblies, makeup to the SFP is provided within 15.36 hours.
- For Phase 2 and 3 event mitigation, an SFP makeup rate of 493.2 L/m (130.3 gpm) is needed to match the initial boiloff rate. The boiloff rate decreases over time as the spent fuel decay heat decreases.

5.1.2.5 Containment Function and Structural Integrity

This subsection presents the operational strategy for containment cooling to ensure the containment function and structural integrity throughout the BDBEE. The APR1400 containment cooling capability to cope with the BDBEE is addressed in this subsection.

5.1.2.5.1 Strategy for Containment Cooling

All of the containment heat removal systems are not credited to operate in the containment pressurization following mass and energy releases from the RCS during the BDBEE. However, even in that condition, the containment conditions need to be maintained within the containment design pressure and the environmental qualification (EQ) temperature that ensure functions of the safety related equipment within the containment as well as the containment structural integrity.

The emergency containment spray backup system (ECSBS) is considered as a means to cool the containment atmosphere, consequently decreasing the containment pressure and temperature below the design limits in such a case that the containment pressure increases following the BDBEE.

The ECSBS is manually actuated when the containment pressure reaches the design pressure. The RWT water is used as the water source for supplying to the ECSBS. The RWT has a sufficient capacity to provide water for the containment cooling including for the core and the SFP cooling.

5.1.2.5.2 Supporting Analyses for Containment Cooling

The containment design incorporates a prestressed concrete containment with a steel liner to house the nuclear steam supply system. The containment and associated systems are designed to safely withstand environmental conditions that may be expected to occur during the life of the plant, including both short-term and long-term effects following a DBA and beyond DBA.

In the supporting analysis for the containment cooling during the BDBEE, the RCP seal LOCA at full-power operation is chosen as the representative case of power operation and shutdown conditions with SGs available to demonstrate maintaining the containment pressure and temperature below the design limits through the FLEX strategy that using the ECSBS.

The APR1400 added a COL item in DCD Chapter 19.3 specifying that the COL applicant is to develop the shutdown risk processes and procedures, and verify the ability to deploy FLEX equipment to provide containment cooling in shutdown operation with SGs not available.

5.1.2.5.2.1 Acceptance Criteria

The following acceptance criteria are applied to ensure the containment function and structural integrity throughout the BDBEE.

- Containment pressure is maintained below the containment design pressure of 4.22 kg/cm² (60 psig) at a BDBEE.
- Containment temperature is maintained at a value less than the EQ temperature of 182 °C (360 °F).

5.1.2.5.2.2 Analytical Methods and Assumptions

Containment pressure and temperature at a BDBEE are analyzed using the GOTHIC (Generation of Thermal-Hydraulic Information for Containments) computer code. The GOTHIC containment model, which was developed for the containment response calculation to a LOCA described in DCD Tier 2 Section 6.2.1, is used to demonstrate the containment capability to cope with the BDBEE. The GOTHIC containment model with analysis methodology are described in Technical Report "LOCA Mass and Energy Release Methodology" (Reference 17) in detail.

The major assumptions used in the containment analysis are listed below:

- The ECSBS is actuated when the pressure reaches the containment design pressure in the containment pressurization following a BDBEE.
- The discharge flow from the RCS leakage is instantly mixed into the containment atmosphere and reaches thermal equilibrium within the containment volume during the transient.
- Variance in local temperature within the containment is not assumed since the accident scenario is characterized by slow, but continuous containment pressurization.

5.1.2.5.2.3 Analytical Results and Conclusion

During the full-power operation, no major pipe break is postulated inside the containment, but RCP seal leakage is assumed to be at a leak rate of 94.64 L/min (25 gpm) per RCP, a total of 378.5 L/min (100 gpm) for four RCPs.

The containment pressure reaches the design pressure of 4.22 kg/cm² (60 psig) after approximately 16 days of the accident, then rapidly decreases and maintains at a low pressure by continuous spray through the ECSBS. The ECSBS FLEX pump provides the flow rate of 2,839 L/min (750 gpm) at a discharge pressure head of 200 m (656 ft).

The containment temperature reaches the highest temperature of 148 °C (298 °F), but which is well below the temperature limit of 182 °C (360 °F) for the environmental qualification of the safety related equipment within the containment. Figure 5-3 and Figure 5-4 show the containment pressure and temperature transients to the RCP seal LOCA, respectively.

From the analysis, it is noted that the containment pressure and temperature are maintained well below the design limits, thereby ensuring the functions of safety-related equipment within containment as well as the containment structural integrity during the BDBEE.

5.1.2.5.3 ECSBS Operation for Containment Cooling

Connection Line

The connection line to the FLEX pump runs inside the containment building through the auxiliary building from the Siamese connection to the ECSBS nozzles, which is designed to Seismic Category I standpipe. The connection line is divided into two quality groups. The line from the Siamese connection to the ECSBS isolation valve (V1013) is designed with Quality Group D and the line from V1013 to ECSBS nozzles is designed with Quality Group B.

A simplified drawing that identifies the flow path to deliver water to the ECSBS is schematically shown in Figure 6-7.

Preparation for ECSBS operation

If the ECSBS operation needs to be used, the following tasks are established.

- a. Mobilize ECSBS FLEX pump and connect the pump suction to the RWT outlet for water supply
- b. Connect pump discharge to the Siamese connection of the ECSBS standpipe
- c. Open the RWT isolation valve in yard and enter general access area in the AB and open ECSBS isolation valve (CS-V1013)

5.1.2.6 Support Systems

5.1.2.6.1 Electrical Systems

This subsection describes the electrical strategies to support the FLEX items described above for NTTFF 4.1 and 4.2.

As stated earlier, the BDBEE causes the unit to lose all ac power. The initial condition is assumed to be a LOOP at a plant site resulting from a BDBEE that affects the offsite power system either throughout the grid or at the plant with no prospect for recovery of offsite power for an extended period. All installed sources of emergency onsite ac power and alternate ac power sources are assumed to be unavailable and not imminently recoverable.

However, the installed electrical distribution system, including inverters and battery chargers, remain available provided they are protected in a manner consistent with current station design.

5.1.2.6.1.1 AC Power

The APR1400 has one 4.16 kVac, 5,000 kW and two 480 Vac, 1,000 kW mobile GTGs for the N+1 requirement, and those mobile GTGs are designed to meet the load requirements as stated in Table 5-5. (See Appendix C for a detailed breakdown of electrical loadings.) The 480 V mobile GTG is credited to power the Class 1E 480 V load centers during Phase 2, while the 4.16 kV mobile GTG is credited to power the Class 1E switchgear during Phase 3.

The 4.16 kV mobile GTG is connected to the 4.16 kV switchgear Train A (or B), and the 480 V mobile GTG is connected to 480 V load center Train A (or B). The provisions to connect these GTGs are incorporated in the APR1400 design. The 4.16 kV GTG powers the 4.16 kV switchgear, 480 V load center and MCC, 480 Vac / 125 Vdc battery charger, 125 Vdc battery, 125 Vdc / 120 Vac inverter, and 120 Vac distribution panel in Train A (or B). The 480 V mobile GTG powers the 480 V load center and MCC, 480 Vac / 125 Vdc battery charger, 125 Vdc battery, 125 Vdc / 120 Vac inverter, and 120 Vac distribution panel in Train A (or B).

During Phase 1, the APR1400 takes credit for Train C or D to which the TDAFWP is connected, while during Phases 2 and 3, the APR1400 takes credit for Train A or B. The ACP is designed to be powered from both Train A and Train B, and the MSADV is designed to be powered from either Train A or Train B. Therefore, during Phases 2 and 3, when the mobile GTG is connected to either Train A or Train B, the APR1400 can be maintained in a safe condition. During Phase 3, the shutdown cooling pump and heat exchanger are used to recover the plant.

5.1.2.6.1.2 DC Power

The APR1400 does not use mobile dc power supplies.

During an ELAP, Class 1E 125 Vdc power is required for operation of 4.16 kV switchgears, 125 Vdc loads, 480 Vac MOVs and AOVs that are backed up by 125 Vdc batteries, I&C panels and shutdown system instrumentation, and 120 Vac loads that are inverted from 125 Vdc batteries.

Both Train A and B batteries have a capacity of 2,800 Ah and can supply dc power up to 2 hours without load shedding and an additional 6 hours with load shedding. Train C and D batteries have a capacity of 8,800 Ah and can supply dc power up to 16 hours without load shedding. The first 8 hours (Phase 1) after the onset of BDBEE, the capacities of all the batteries are sufficient to provide dc power to all essential loads necessary to perform their safety duties.

During Phase 2, a 480 V mobile GTG is connected to either Train A or Train B of the Class 1E load center to supply power and recharge respective batteries to fully charged condition.

Battery Qualification

The safety-related batteries that are extended for use longer than 8 hours, with reduced discharge rate through load shedding, are not required to be additionally qualified for FLEX profiles since the NRC endorsed the NEI White Paper with clarifications in September 2013 (References 10 and 11).

5.1.2.6.1.3 Emergency Lighting

Emergency dc lighting in areas such as the MCR and technical support center (TSC) / operational support center (OSC) is provided from the Class 1E batteries during Phase 1, and emergency ac lighting is provided from the mobile GTG during Phases 2 and 3.

Access to manual valves requires lighting, and access to instrumentation monitoring or equipment operation also requires lighting. Under this adverse condition, the APR1400 is designed to provide portable lighting (e.g., flashlights or headlamps) as necessary to perform essential functions.

5.1.2.6.1.4 Communications

Design features are incorporated into onsite plant communication system to enhance emergency preparedness for BDBEES associated with simultaneous LUHS. These are described below.

The APR1400 communication subsystems provide an independent and diverse mode of communications. A failure of one subsystem does not affect the capability to communicate using the other system.

Electric power is provided to the communications subsystems from the non-Class 1E uninterruptible power system (UPS) with 1-hour capacity in normal operation. The wireless communication system is supplied from the dedicated emergency UPS with 16-hour capacity.

However, normal communications may be lost or hampered during an ELAP. In this condition, portable communication devices are provided to support interaction between personnel in the plant and those

providing overall command and control. Communication gear (satellite phones and radios) are also provided for onsite and offsite communications. This system provides an alternate communication path for outside connections. The satellite telephone equipment includes a roof-mounted antenna and transceiver.

5.1.2.6.2 Water Supply System

The primary source of water for the core cooling function is the AFWST for the first 72 hours, and the RWT can be used thereafter for up to 11 days, if required (Table 5-2).

For the SFP makeup and spray function, the RWT is the source of water.

The detailed design of the RWT related with site specific data is the responsibility of COL applicant. The COL applicant will confirm, satisfy, or fulfill the specific design functional requirements of raw water tank including the associated instrument, capacity, location, flow path to on-site, the valve pit connected to FLEX equipment, and any other design features as described in DCD Section 19.3 in support of BDBEE mitigation strategies. Also, the COL applicant will confirm and ensure that the RWT and flow path to the FLEX equipment (structures, piping, components, and connections) are designed to be robust with respect to applicable hazards (e.g., seismic events, floods, high winds, and associated missiles).

5.1.2.6.3 Fuel Oil Supply System

EDG fuel oil day tank and the underground 7-day fuel oil storage tanks are used for running the diesel-driven FLEX pumps. During Phase 3, fuel oil is provided from an offsite source. Table 5-6 provides a summary of the fuel oil demands during the three phases of this event.

The existing onsite EDG fuel oil storage tanks and associated diesel fuel oil day tanks have a capacity of at least 32 days to sustain the demand for fuel oil during full-power mode operation

5.1.2.7 Summary of APR1400 Mitigation Capability for FLEX

The APR1400 baseline capability is sufficient to support the safety functions of core cooling, containment function, and SFP cooling after BDBEE, with simultaneous loss of all ac power and LUHS. However, FLEX equipment stored onsite (or offsite) will be used to support the mitigation of a BDBEE resulting in an ELAP and LUHS. The APR1400 mitigation capability of the BDBEE is summarized in Table 5-7, which is based on the NEI 12-06 (Reference 8) FLEX capability matrix table. This table outlines baseline and FLEX capabilities of the APR1400 to maintain safety functions of core cooling, containment, and SFP cooling.

5.1.2.8 Conformance with NRC/NEI Recommendations

Conformance with JLD-ISG-2012-01 (Reference 7) is addressed in Table 5-8.

Conformance with NEI 12-06 (Reference 8) is addressed in Table 5-9.

Conformance with NEI 12-06, Tables D-1, D-2, and D-3 (Reference 8) is addressed in Table 5-10.

5.1.3 Recommendation 7.1 – SFP Instrumentation

5.1.3.1 Introduction

Recommendation 7.1 is a Tier 1 recommendation that resulted in the issuance of NRC Order EA-12-051 (Reference 6). The Order modified licenses to require a reliable indication of the water level in associated

spent fuel storage pools capable of supporting identification of the following pool water level conditions by trained personnel: (1) level that is adequate to support operation of the normal fuel pool cooling system, (2) level that is adequate to provide substantial radiation shielding for a person standing on the spent fuel pool operating deck, and (3) level where fuel remains covered and actions to implement makeup water addition should no longer be deferred.

The APR1400 SFP water level instrumentation is consistent with the guidelines in NRC EA-12-051 (Reference 6), NEI 12-02 Rev. 1 (Reference 12), and JLD-ISG-2012-03 Rev. 0 (Reference 13) as described in the following subsection.

5.1.3.2 Basic Strategy

The strategy for addressing NTTF 7.1 SFP instrumentation is described below.

5.1.3.2.1 Identification of Spent Fuel Pool Water Levels

The following are the key spent fuel pool water levels:

- Level 1: Level adequate to support operation of the normal SFP cooling system

Indicated water level on either the primary or backup instrument channel of greater than EI. 144 ft 0in (based on ensuring the open end of the normal suction lines does not become uncovered) plus the accuracy of the SFP water level instrument channel.

- Level 2: Level adequate to provide substantial radiation shielding for a person standing on the spent fuel pool operating deck

Indicated level on either the primary or backup instrument channel of greater than 3.05 m (+/-0.305 m) (10 ft [+/- 1 ft]) above the top of the fuel storage racks. The 3.05 m (10 ft) criterion is conservative with regard to dose, in that the APR1400 DCD Subsections 9.1.3.1 and 9.1.3.3.4 indicate that dose would remain at or below 0.025 mSv (2.5 mrem/hr) at the surface of the water. This monitoring level provides reasonable assurance that there is adequate water level to provide substantial radiation shielding for a person standing on the spent fuel pool operating deck. The elevation associated with this level is greater than 139 ft 8 in plus the accuracy of the SFP water level instrument channel, which is determined at the COL stage.

- Level 3: Level where fuel remains covered and actions to implement makeup water addition should no longer be deferred

Indicated level is on either the primary or backup instrument channel of greater than 0.305 m (1 ft) above the top of the fuel storage racks. The elevation associated with this level is greater than 129 ft 8 in plus the accuracy of the SFP water level instrument channel, which is determined at the COL stage. This monitoring level provides reasonable assurance that there is adequate water level above the stored fuel in the rack.

5.1.3.2.2 Instruments

The design of the instruments is consistent with the guidelines of NRC JLDISG-2012-03 Rev. 0 and NEI 12-02 Rev. 1. Specifically, the channels are designed as described below.

- Primary (fixed) instrument channel (Channel A)

The primary instrument channel provides level indication through the use of guided wave radar (GWR) technology using the principle of time domain reflectometry (TDR). The instrument provides a single continuous span from above Level 1 to within 0.305 m (1 ft) of the top of the spent fuel racks.

- Backup instrument channel (Channel B)

The backup instrument channel is identical to the primary channel and is a permanent, fixed channel. The backup instrument channel provides level indication through the use of GWR technology using the principle of TDR. The instrument provides a single continuous span from above Level 1 to within 0.305 m (1 ft) of the top of the spent fuel racks.

The primary and backup instrument channels provide continuous level indication over a minimum range from the high SFP alarm El. 154 ft 2 in plus the accuracy of the SFP water level instrument channel to the top of the spent fuel racks at El. 129 ft 8 in minus the accuracy of the SFP water level instrument channel.

5.1.3.2.3 Reliability

Conformance with the guidelines of NRC JLD-ISG-2012-03 Rev. 0 and NEI 12-02 Rev. 1 provides reasonable assurance of the reliability of the primary and backup instrument channels, as described in the subsections below. The GWR design was selected due to its reliability.

5.1.3.2.4 Instrument Channel Design Criteria

Instrument channel design is consistent with the guidelines of NRC JLD-ISG2012-03 Rev. 0 and NEI 12-02 Rev. 1.

Instrument channels consist of a corrosion- and radiation-resistant metal probe submerged in the pool and connected to a corresponding display/processor by coaxial cable. The probe spans the length of the measured range of pool levels.

The probe is seismically mounted. It is designed to operate in borated and non-borated water over the entire expected range of pool conditions from normal temperatures to boiling temperatures. Cables and connections are designed for expected radiation levels and environments of greater than 100 °C (212 °F) and 100 percent humidity. Probes, cables, connectors, and mounting hardware in the area of the SFP are designed to function after the effects of seismically induced sloshing.

In the SFP area, cables shall be routed in seismically mounted rigid metal conduit. Outside the pool area, cables shall be routed in seismically mounted rigid metal conduit, trays, or raceways. Display/processors shall be mounted in promptly accessible areas outside of the SFP area as defined in Subsection 5.1.3.2.7 of this report.

Channels shall be physically separated by routing instrument cables in separate conduits, trays, or raceways, locating sensors on opposite sides of the pool near the corners, etc. Physical channel separation is maintained down through and including each channel display/processor where convergence may be allowed so that display/processors can be located close to each other or side by side.

Movement of the probe during a seismic event does not damage the pool liner and does not result in contact with spent fuel. Indication remains reliable after a seismic event.

Minor debris buildup on the probe does not impact performance.

5.1.3.2.5 Arrangement

The channels/probes of level instruments are separated to reduce the potential for falling debris or

missiles affecting both channels of instrumentation. This placement, coupled with separate routing paths for cables and use of rigid conduit, provides reasonable protection against falling debris and structural damage.

Instrument power is derived from the Class 1E 480 V MCC. The MCC is located in the auxiliary building. The MCC is expected to be in a mild environment after a BDBEE and can be easily accessed from the MCR; therefore, personnel can promptly obtain readings from the display. This building provides adequate protection against the effects of temperature, flood, humidity, radiation, seismic events, and missile hazards.

5.1.3.2.6 Mounting

Both the primary and backup systems are installed as seismic Category I to meet the NRC JLD-ISG-2012-03 and NEI 12-02 guidance requirements.

Other hardware stored in the SFP is evaluated to provide reasonable assurance that it does not adversely interact with the SFP instrument probes during a seismic event.

5.1.3.2.7 Qualification

Design criteria will provide reasonable assurance of instrument channel reliability during normal, event, and post-event conditions for no fewer than 7 days or until offsite resources can be deployed. The combination of analyses, operating experience, and/or manufacturer testing of channel components includes practices that are used to validate design criteria and considers the following:

- Post-event conditions in the area of instrument channel components used for all instrument components
- Effects of shock and vibration on all instrument channel components used during and following any applicable event for installed components
- Seismic effects on instrument channel components used during and following a potential seismic event for installed components

Components in the area of the SFP are designed for the temperature, humidity, and radiation levels expected during normal, event, and post-event conditions for no fewer than 7 days post-event or until offsite resources can be deployed by the mitigating strategies resulting from Order 12-049, "Order Modifying Licenses With Regard to Requirements for Mitigation for Beyond-Design-Basis External Events." Examples of post-event conditions that are considered are:

- Radiological conditions for a normal refueling quantity of freshly discharged (100 hours) fuel with SFP water level within 0.305 m (1 ft) of the top of the SFP racks (Level 3)
- Temperature of 100 °C (212 °F) and 100 percent relative humidity environment
- Boiling water and steam environment
- The mitigating strategies developed in response to NEI 12-06, Diverse and Flexible Coping Strategies (FLEX)

Equipment located in the SFP is qualified to withstand a total accumulated dose of expected lifetime at normal conditions plus accident dose received at post-event conditions with SFP water level within 0.305 m (1 ft) of the top of the fuel rack seated in the spent fuel pool (Level 3).

The metal probe and cable in the spent fuel pool area are robust components that are not adversely affected by expected radiation, temperature, or humidity. The areas selected for display/processor installation are considered mild environments in which personnel access is not prohibited by radiation, temperature, or humidity, and are readily accessible by operators during or after a BDBEE.

Components of the instrument channels are qualified for shock and vibration using one or more of the following methods:

- Components are supplied by manufacturers that implement commercial quality programs (such as ISO 9001, Quality Management Systems – Requirements) with shock and vibration requirements included in the purchase specification at levels commensurate with portable hand-held devices or transportation applications.
- Components have a history of operational reliability in environments with significant shock and vibration loading, such as portable hand-held device or transportation applications.
- Components are inherently resistant to shock and vibration loadings, such as cables.

Demonstration of seismic adequacy is achieved using one or more of the following methods:

- Demonstration of seismic motion consistent with that of existing design basis loads at the installed location.
- Substantial history of operational reliability in environments with significant vibration, such as for portable hand-held devices or transportation applications. Such a vibration design envelope shall be inclusive of the effects of seismic motion imparted to the components proposed at the location of the proposed installation.
- Adequacy of seismic design and installation is demonstrated based on the guidance in Sections 7, 8, 9, and 10 of Institute of Electrical and Electronics Engineers (IEEE) Standard 344-2004, “IEEE Recommended Practice for Seismic Qualification of Class 1E Equipment for Nuclear Power Generating Stations” (Reference 14).
- Demonstration that proposed devices are substantially similar in design to models that have been previously tested for seismic effects in excess of the plant design basis at the location where the instrument is to be installed (g-levels and frequency ranges).
- Seismic qualification using seismic motion consistent with that of existing design basis loading at the installation location.

In those cases where the commercial quality program does not address the seismic levels and frequencies, additional analysis or testing will be provided.

5.1.3.2.8 Independence

The primary instrument channel is independent of the backup instrument channel. Independence is obtained by physical separation of components between channels and the separate use of Class 1E MCC. The two permanently mounted instruments in the pool are physically separated as described in Subsections 5.1.3.2.4 and 5.1.3.2.5.

5.1.3.2.9 Power Supplies

The power supplies for the instrument channels are as follows:

- Each instrument channel is normally powered from a 120 Vac 60 Hz distribution panel of Class 1E 480 Vac MCC to support continuous monitoring of SFP level.
- On loss of normal 120 Vac power from the Class 1E 480 V MCC, each channel's internal UPS automatically transfers instrument power to a dedicated backup battery. If normal ac power is restored, the UPS automatically transfers instrument power back to the normal ac power.
- The dedicated backup batteries are sized to be capable of supporting continuous monitoring of SFP level for a minimum of 72 hours of operation. This provides adequate time until the onsite or offsite mobile GTG can supply the power by mitigating strategies resulting from the ELAP event.
- Instrument accuracy and performance are not affected by restoration of power or restarting the processor.

5.1.3.2.10 Accuracy

Accuracy is consistent with the guidelines of NRC JLD-ISG-2012-03 Rev. 0 and NEI 12-02 Rev. 1. Accuracy and indication features are as follows:

- Accuracy: The absolute system accuracy is better than ± 7.62 cm (± 3 in). This accuracy is applicable for normal conditions and the temperature, humidity, chemistry, and radiation levels expected for BDBEE conditions.
- Trending: The display trends and retains data when powered from either normal or backup power.
- Restoration after loss of power: The system automatically swaps to available power (backup battery power or external dc source) when normal power is lost. Neither the source of power nor system restoration impact accuracy. Previously collected data are retained.
- Diagnostics: The system performs and displays the results of real-time information related to the integrity of the cable, probe, and instrument channel.

The above features provide reasonable assurance that trained personnel can easily determine when SFP level falls below each regulatory level (Levels 1, 2, and 3) without conflicting or ambiguous indication.

5.1.3.2.11 Testing

Testing and calibration are consistent with the guidelines of NRC JLD-ISG-2012-03 Rev. 0 and NEI 12-02 Rev. 1.

The display/processor performs automatic in-situ calibration and automatically monitors for cable, connector, and probe faults using TDR technology. Channel degradation due to age or corrosion is not expected but can be identified by monitoring trends.

The COL applicant should develop the station procedures and preventive maintenance tasks to perform required surveillance testing, calibration, backup battery maintenance, functional checks, and visual inspections of the probes.

5.1.3.2.12 Display

The primary and backup level instruments are continuously displayed in the main control room and remote shutdown room.

The displays are consistent with the guidelines of NRC JLD-ISG-2012-03 Rev. 0 and NEI 12-02 Rev. 1.

5.1.3.2.13 Instrument Channel Program Criteria

The COL applicant should perform training and address the SFP level instrumentation maintenance procedure development in accordance with the guidelines of NRC JLD-ISG-2012-03 Rev. 0 and NEI 12-02 Rev. 1 as described below.

- Training

The systematic approach to training (SAT) is used to identify the population to be trained and to determine both the initial and continuing elements of the required training. Training is completed prior to placing the instrumentation in service.

- Procedures

Procedures for maintenance and testing are developed using regulatory guidelines and vendor instructions.

BDBEE operation guidance also addresses the following:

- A strategy to ensure SFP water addition is initiated at an appropriate time consistent with implementation of NEI 12-06 Rev. 1.
- Restoration of non-functioning SFP level channels after an event. Restoration timing is consistent with the emergency condition. After an event, commercially available components that may not meet all qualifications may be used to replace components to restore functionality.

5.1.3.3 Conformance with Regulatory Recommendations

Conformance with NEI 12-02, "Industry Guidance for Compliance with NRC Order EA-12-051, To Modify Licenses with Regard to Reliable Spent Fuel Pool Instrumentation," Rev. 1 (Reference 12), which the NRC has endorsed in JLD-ISG-2012-03, Rev. 0 (Reference 13), is summarized in Table 5-11.

SFP decay heat removal capacity is evaluated complying with NEI 12-06, Section 3.2.1.6 and summarized in Subsection 5.1.2.4.2.

5.1.4 Recommendation 8 – Emergency Response

For the APR1400, NRC Rulemaking is applied. The final rule and draft guidance is due to the Commission by March 11, 2016.

COL applicants will develop emergency operating procedures (EOPs), severe accident management guidelines (SAMGs), and extensive damage mitigation guidelines (EDMGs) for their units that comply with the NRC rule for onsite emergency response that was issued in the NRC Advance Notice of Proposed Rulemaking (ANPR) on April 18, 2012 and is planned to be finally issued by the 3rd quarter of 2016 as described in SECY-12-0025 (Reference 3).

The APR1400 added a COL item in DCD Chapter 19.3 specifying that COL applicant address strengthening and integration of EOPs, SAMGs, and EDMGs.

5.1.5 **Recommendation 9.3 – Emergency Plan (only staffing and communications equipment portion in Tier 1)**

5.1.5.1 **Communication Equipment**

Considering the Request for Information (RFI) on NTTF Recommendation 9.3, "Emergency Preparedness" depicted in Enclosure 5 to SECY-12-0025 (Reference 15) and NEI 12-01(Reference 16), the following design features are incorporated into the onsite plant communication system to enhance emergency preparedness for a BDBEE associated with simultaneous loss of all ac power and LUHS, in addition to the existing design features of the station communication system:

1. Addition of power sources for the wireless communication systems
2. Introduction of a satellite telephone link

Regarding offsite communications, a new COL item is added in the DCD Chapter 19.3 specifying that COL applicants are to address the offsite communication requirements specified in Enclosure 5 to SECY-12-0025.

5.1.5.2 **Staffing**

COL applicants that construct an APR1400 are responsible to conduct staffing evaluations for the unit in response to the emergency planning staffing provisions of Recommendation 9.3. A new COL item is added in DCD Chapter 19.3 specifying that COL applicants are to address staffing evaluations for the unit, considering the requested functions described in Recommendation 9.3, Items 1 through 4 and 6 (Reference 1), including those related to NTTF Recommendation 4.2.

5.2 **Tier 2 Items**

5.2.1 **Recommendation 7.2 – Safety-Related ac Electrical Power for the SFP Makeup System**

NTTF Recommendation 7.2 is a Tier 2 recommendation that requests safety-related ac power for the SFP makeup system.

The APR1400 design provides the AFWSTs as a seismic Category I makeup water source for SFP. The makeup water is delivered to the SFP via component cooling water (CCW) makeup pumps, which are powered by safety-related ac power.

5.2.2 **Recommendation 7.3 – Plant Technical Specifications**

NTTF Recommendation 7.3 is a Tier 2 recommendation that requests that Plant Technical Specifications require one train of emergency onsite electrical power to be operable for SFP makeup/instrumentation when there is irradiated fuel in the SFP, regardless of plant operating mode.

The APR1400 Technical Specifications require at least one EDG and one CCW makeup pump to be operable in all modes. The safety-related CCW makeup pumps are powered by the EDGs. The CCW makeup is capable of providing makeup to the SFP.

Refer to the APR1400 DCD Tier 2, Chapter 16, Technical Specification 3.8.1.

5.2.3 **Recommendation 7.4 – Seismically Qualified Spent Fuel Pool Spray System**

Recommendation 7.4 is a Tier 2 recommendation that requests that a seismically qualified means to spray water into SFPs be provided, including an easily accessible connection to supply water, such as

using a FLEX pump or pumper truck, at grade level outside of the building

The APR1400 design provides a diverse spent fuel pool makeup and spray system as described in this report that meets the criteria specified in this recommendation.

5.2.4 Recommendation 7.5 – Spent Fuel Pool Actions Related to Recommendations 7.1 through 7.4

Considering “Near-Term Report and Recommendations for Agency Actions Following the Events in Japan,” dated July 12, 2011 (Reference 1), the SFP diverse makeup lines and spray lines of the APR1400 are designed to withstand a safe shutdown earthquake (SSE).

5.2.5 Recommendation 9.3 – Emergency Preparedness Regulatory Actions (remaining portions of Recommendation 9.3, except Emergency Response Data System – ERDS capability addressed in Tier 3)

COL applicants that construct an APR1400 will be implementing improved emergency preparedness activities, which the NTTF Recommendation intends.

In SECY-12-0095 (Reference 4), the NRC staff proposed a project plan for publication of an ANPR on emergency preparedness activities addresses the Tier 2 and Tier 3 components of NTTF Recommendation 9.3, as summarized in Table 4-1 of this Technical Report.

5.2.6 Recommendation 2.1 – Other External Events

This was newly added as a Tier 2 issue in SECY-12-0025. As the intent of the recommendation is re-evaluation of the existing operating reactors against a set of new plant evaluation criteria and the other external events have been fully evaluated in the APR1400 DCD, neither KHNP nor COL applicants need take action on this recommendation.

5.3 Tier 3 Items (and Other Items)

5.3.1 Recommendation 2.2 – Ten-Year Confirmation of Seismic and Flooding Hazards (dependent on Recommendation 2.1)

This recommendation is only applicable to operating plants. Therefore, neither KHNP nor COL applicants will take any action on this recommendation.

5.3.2 Recommendation 3 – Potential Enhancements to the Capability to Prevent or Mitigate Seismically-Induced Fires and Floods (Long-Term Evaluation)

Neither KHNP nor COL applicants are required to take action because in SECY-12-0095 (Reference 4), the NRC staff proposed that it will defer the evaluation of NTTF Recommendation 3 (Reference 1) until 2016.

5.3.3 Recommendation 5.2 – Reliable Hardened Vents for Other Containment Designs (Long-Term Evaluation)

The staff plans to defer consideration of venting for other containment designs (e.g., Mark III, ice condenser, and large dry containments) until the Commission reaches a decision on the need for severe accident venting and filtered venting for BWR Mark I and Mark II containments. Therefore, KHNP will not take action on this recommendation at this time.

5.3.4 Recommendation 6 – Hydrogen Control and Mitigation inside Containment or in Other Buildings

The NRC plans to develop and issue a rule on hydrogen control and mitigation inside the containment or in other buildings as a long-term issue. Currently, there is an insufficient information to substantiate changes to the current APR1400 design. Therefore, KHNP will not take action on this recommendation at this time.

5.3.5 Recommendations 9.1 and 9.2 – Emergency Preparedness (EP) Enhancements for Prolonged SBO and Multiunit Events

The NRC plans to develop and issue a rule on emergency preparedness by 2016. No action is required at this time.

5.3.6 Recommendation 9.3 – ERDS Capability

The NRC plans to develop and issue a rule on emergency preparedness by 2016. No action is taken.

5.3.7 Recommendation 10 – Additional EP Topic for Prolonged SBO and Multiunit Events

The NRC plans to develop and issue a rule on emergency preparedness by 2016. No action is taken.

5.3.8 Recommendation 11 – EP Topics for Decision-Making, Radiation Monitoring, and Public Education

The NRC plans to develop and issue a rule on emergency preparedness by 2016. No action is required at this time.

5.3.9 Recommendation 12.1 – Reactor Oversight Process Modifications to Reflect the Recommended Defense-in-Depth Framework

The NRC staff proposed in SECY-12-0095 that the staff will defer action on Recommendation 12.1 until the Commission has provided staff guidance regarding Recommendation 1. No action is required at this time.

5.3.10 Recommendation 12.2 – Staff Training on Severe Accidents and Resident Inspector Training on SAMGs

This recommendation is related to the NRC. No action is required at this time.

5.3.11 Additional Recommendations

There are two additional recommendations as follows:

- Emergency planning zone (EPZ)
- Pre-staging of potassium iodide beyond 16,093 m (10 miles)

As these recommendations concern the fundamental issue of existing regulatory framework that should be developed by the NRC, no action is required.

Table 5-1 Sequence of Events for Core Cooling (Full-Power Operation) (1 of 2)

TS

Table 5-1 Sequence of Events for Core Cooling (Full-Power Operation) (2 of 2)

TS



Table 5-2 Water Volume Source and Requirements for SG Feedwater

Tank	Quantity	Tank Volume, m ³ /tank (gal/tank)	Total Volume, m ³ (gal)	Phase 1 – Total Volume Required, m ³ (gal)	Phase 1 & 2 – Total Volume Required, m ³ (gal)
Auxiliary Feedwater Storage Tank (AFWST)	2	1,819.61 (480,690)	3,639.22 (961,380)	529.96 (140,000)	2,849.69 (752,809) Primary source of water is AFWST for 72 hours. RWT can be used after depletion of AFWSTs for up to 11 days following the event.
Raw Water Tank (RWT)	2	4,996.74 (1,320,000)	9,993.49 (2,640,000)	NA	

Table 5-3 FLEX Capability – Spent Fuel Pool Cooling Summary

Safety Function	Method	Phase 1	Phase 2 and 3
Spent Fuel Pool Cooling	Makeup through connection to SFP makeup piping or other suitable means (e.g., sprays)	Analysis demonstrates that spent fuel heats up slowly and remains cooled by water inventory above the top of the spent fuel rack.	Permanent connections for FLEX, self-powered SFP makeup pump and SFP spray pump. (FLEX connection locations and equipment are protected from the applicable hazards in NEI 12-06. They are designed to seismic Category I requirements. They either are located in seismic Category I structures or outside, above the ground).
	Makeup with FLEX injection source	Analysis demonstrates that spent fuel heats up slowly and remains cooled by water inventory above the top of the spent fuel rack.	Permanent connections to make up the SFP from RWT.
	Vent pathway for steam	Vent path from SFP area to environment established for removal of steam. (Rollup door to the fuel handling area truck bay is opened prior to earliest predicted spent fuel pool time to boil.)	Vent path established in Phase 1 is maintained open to provide a vent path for steam.
SFP Parameters	SFP level	Instruments powered by Class 1E MCC.	On loss of normal 120 Vac power from the Class 1E 480 V MCC, each channel's internal UPS automatically transfers instrument power to a dedicated backup battery to support continuous monitoring of SFP level. If normal ac power is restored, the UPS will automatically transfer instrument power back to the normal ac power.
		The APR1400 design includes redundant, safety-related wide-range level sensors in SFP that fulfill EA-12-051 order.	

Table 5-4 480 V and 4.16 kV Mobile GTG Electrical Load Summary List (in kW)

Electrical Load Description		Train A	Train B	Remark
480V Mobile GTG	Loads	762.4	810.4	Rating: 1,000 kW
	Total (with 10% margin)	838.6	891.4	
4.16 kV Mobile GTG	Loads	4,204.48	4,217.94	Rating: 5,000 kW
	Total (with 10% margin)	4,624.93	4,639.09	

Table 5-5 Summary of Fuel Oil Demand (most limiting)

Phase	Purpose	Fuel Oil Source	Equipment (Specification)	Fuel Oil Volume required Liters (gal)	Remark
Phase 1	Core cooling	NA			
Phase 2 (modes 1~4)	Power supply	EDG fuel oil storage tank and day tank	GTG (480 V/1,000 kW)	29,072 (7,680)	7.57 L/min (2.0 gpm)
	Core cooling		Two secondary FLEX pumps (each 1,174 L/min, 160 m [310 gpm, 525 ft])	2,764 (730)	0.36 L/min (0.095 gpm)
	RCS makeup		One primary high-head FLEX pump (190 L/min, 17 kg/cm ² A [50 gpm, 243 psia])	2,060 (544)	0.54 L/min (0.142 gpm)
	SFP cooling (No full core offload)		- One SFP makeup FLEX pump (1,893 L/min [500 gpm]) - SFP spray (757 L/min [200 gpm])	174 (46) 379 (100)	 An alternate means of SFP makeup FLEX pump
Phase 3	RCS makeup SFP cooling	Resources external (COL)			

Table 5-6 APR1400 FLEX Capability Summary (1 of 3)

Safety Function		Method	Capabilities	FLEX Equipment
Core Cooling and RCS Inventory	Core Cooling (SGs available): Modes 1 through 5	<p>Phase 1:</p> <ul style="list-style-type: none"> • NCC • TDAFWP-SG-MSSV-AFWST <p>Phase 2:</p> <ul style="list-style-type: none"> • NCC • TDAFWP-AFWST-SG-MSADV • ACP, SIT • FLEX pumps • Load shedding • 480 V mobile GTGs • IRWST, AFWST <p>Phase 3:</p> <ul style="list-style-type: none"> • Same as Phase 2 • RWT • Offsite resources • 4.16 kV mobile GTG 	<ul style="list-style-type: none"> • Use of installed equipment (TDAFWP-SG-MSSV-MSADV, ACP, SIT, UHS, SCS) • Use of water supply (AFWST, RWT, IRWST) • Use of a primary side high-head FLEX pump if ACP is not available • Use of secondary side FLEX pumps if TDAFWPs are not available • Connection for FLEX pumps to supply water • Use of UHS/SCS instead of the NCC cooling with MSADVs and TDAFWPs after the 4.16 kV mobile GTG is connected, if UHS is restored 	<ul style="list-style-type: none"> • Onsite self-powered primary high-head FLEX pump • Onsite self-powered secondary side FLEX pump to directly supply water to SG • 480 V onsite mobile GTG • 4.16 kV offsite mobile GTG
	Core Cooling (SGs unavailable): Modes 5 and 6	<p><u>Phase 1</u></p> <ul style="list-style-type: none"> • Decay heat is removed by boiloff from the core • Feed-and-bleed by external injection using FLEX pump • Available borated water source (COL 19.3(17)) • 480 V mobile GTGs <p><u>Phase 3</u></p> <ul style="list-style-type: none"> • 4.16kV mobile GTG • UHS/SCS • Available borated water source (COL 19.3(17)) • Offsite resources 	<ul style="list-style-type: none"> • Use of water supply (IRWST) • Vent steam through PZR manway • Use of FLEX pump • RCS makeup connections for a FLEX primary side pump • Use of UHS/SCS instead of the NCC cooling with MSADVs and TDAFWPs after the 4.16 kV mobile GTG is connected, if UHS is restored 	<ul style="list-style-type: none"> • Onsite self-powered primary side FLEX pump to make up RCS • 480 V onsite mobile GTG • 4.16 kV offsite mobile GTG

Table 5-6 APR1400 FLEX Capability Summary (2 of 3)

Safety Function		Method	Capabilities	FLEX Equipment
	RCS Inventory/ Boration (SGs available): Modes 1 through 5	<ul style="list-style-type: none"> Low-leakage RCP seals (leakage assumed to be 94.64 L/m [25 gpm] per RCP) Provide borated RCS makeup 	<ul style="list-style-type: none"> Use of ACP or primary side high-head FLEX pump for RCS makeup with borated water SIT for boration 	<ul style="list-style-type: none"> Onsite self-powered primary side FLEX 480 V onsite mobile GTG 4.16 kV offsite mobile GTG
	RCS Inventory/ Boration (SGs not available): Modes 5 and 6	<ul style="list-style-type: none"> RCS feed and bleed 	<ul style="list-style-type: none"> Use of primary side low-head FLEX pump for RCS makeup 	<ul style="list-style-type: none"> Onsite self-powered primary side FLEX pump
	Key Instrumentation	<ul style="list-style-type: none"> SG water level and pressure AFWST water level RCS hot leg (HL) and cold leg (CL) temperature Pressurizer (PZR) water level and pressure Core exit temperature 	<ul style="list-style-type: none"> Instruments powered by Class 1E dc bus 	<ul style="list-style-type: none"> Onsite mobile GTG
Containment Integrity	Containment Cooling	<ul style="list-style-type: none"> Containment Structure ECSBS 	<ul style="list-style-type: none"> Source of water (AFWST, RWT) ECSBS spray 	<ul style="list-style-type: none"> Onsite self-powered FLEX pumps to provide containment cooling, with hoses and couplings
	Key Containment Instrumentation	<ul style="list-style-type: none"> Containment pressure 	<ul style="list-style-type: none"> Key instruments powered by Class 1E dc bus 	<ul style="list-style-type: none"> None
SFP Cooling	SFP Cooling	<ul style="list-style-type: none"> SFP makeup and SFP spray 	<ul style="list-style-type: none"> Use of installed equipment (RWT) Use of FLEX pumps SFP makeup lines and SFP spray lines from yard connections to SFP Vent pathway for steam and condensed vapors from SFP area 	<ul style="list-style-type: none"> Onsite self-powered FLEX pumps to makeup SFP, with hoses and couplings
	SFP Instruments	<ul style="list-style-type: none"> SFP level instrumentation 	<ul style="list-style-type: none"> Two sets of wide range (Level 1 to 3) safety-related, continuous SFP level instruments 	<ul style="list-style-type: none"> Onsite mobile GTG

Table 5-6 APR1400 FLEX Capability Summary (3 of 3)

Safety Function	Method	Capabilities	FLEX Equipment	
Support Function	ac Power	<ul style="list-style-type: none"> Mobile ac power source 	<ul style="list-style-type: none"> ac distribution system including inverters and battery chargers installed 	<ul style="list-style-type: none"> One 4.16 kV mobile GTG / two 480 V mobile GTGs (N+1 requirement)
	dc Power	<ul style="list-style-type: none"> dc power source via battery chargers dc distribution system 	<ul style="list-style-type: none"> dc distribution system including inverters and battery chargers installed 	<ul style="list-style-type: none"> One 4.16 kV mobile GTG / two 480 V mobile GTGs (N+1 requirement)
	HVAC	<ul style="list-style-type: none"> HVAC system for MCR , electrical and I&C equipment rooms, ACP room, and TDAFWP room 	<ul style="list-style-type: none"> HVAC system for MCR, electrical and I&C equipment rooms, ACP room, and TDAFWP pump room 	<ul style="list-style-type: none"> No cooling is necessary for MCR, electrical and I&C equipment room, ACP room and the TDAFWP room as the heatup temperature does not exceed the design temperature of the room during BDBEE
	Lighting	<ul style="list-style-type: none"> Emergency lighting systems 	<ul style="list-style-type: none"> Emergency lighting powered from Class 1E 125 Vdc batteries Emergency portable lighting 	<ul style="list-style-type: none"> Onsite mobile GTG to recharge the Class 1E batteries
	Communication	<ul style="list-style-type: none"> Communication systems 	<ul style="list-style-type: none"> Plant communication systems powered by Non-Class 1E UPS for 1 hour Emergency wireless communication devices powered by dedicated emergency UPS for 16 hours 	<ul style="list-style-type: none"> Onsite mobile GTG to recharge the batteries supplying to Class 1E MCCs
	Fuel Oil	<ul style="list-style-type: none"> Fuel oil system 	<ul style="list-style-type: none"> Connection for onsite emergency diesel generator fuel oil system 	<ul style="list-style-type: none"> Onsite EDG fuel oil storage tanks Onsite EDG fuel oil day tanks External resources
	Makeup Water	<ul style="list-style-type: none"> Makeup water source 	<ul style="list-style-type: none"> AFWST for TDAFW pump and backup from RWT RWT for SFP makeup and SFP spray operation 	<ul style="list-style-type: none"> See the FLEX equipment for core cooling, SFP cooling for components External water source

Table 5-7 Conformance with JLD-ISG-2012-01, Rev. 0 (1 of 5)

JLD-ISG-2012-01 Rev. 0		APR1400
Section	Summary	
1.0	<p>Evaluation of External Hazards</p> <p>NEI 12-06, Section 4 describes the overall methodology for evaluating the impact of the hazards, described in Sections 5.0 through 9.0, on the deployment of the strategies to meet the baseline coping capability.</p>	<p>COL applicants are responsible to assess the site-specific external hazards in accordance with the guidance.</p>
2.0	<p>Phased Approach</p> <p>Order EA-12-049 requires a three-phase approach to mitigating beyond-design-basis events, with an initial response phase using installed equipment, a transition phase using portable equipment and consumables to provide core and spent fuel pool (SFP) cooling and maintain the containment functions, and a third phase of indefinite sustainment of these functions using offsite resources. Maintenance of core and SFP cooling and containment functions requires overlap between the initiating times for the phases with the duration for which each licensee can perform the prior phases. The NRC staff recognizes that for certain beyond-design-basis external events, the damage state could prevent maintenance of key safety functions using the equipment intended for particular phases. Under such circumstances, prompt initiation of the follow-on phases to restore core and SFP cooling and containment functions is appropriate. If fuel damage occurs, the Severe Accident Management Guidelines should be used as guidance.</p>	<p>The APR1400 FLEX strategy complies with the guidance. The APR1400 FLEX strategy to provide core and SFP cooling, and to maintain containment integrity when ELAP and LUHS are assumed to occur simultaneously, follows the three-phase approach as requested in Order EA-12-049. The three-phase operations consist of an initial response phase using installed equipment, a transition phase using FLEX equipment and consumables to provide core cooling, and a third phase of indefinite sustainment of these functions using offsite resources.</p>
2.1	<p>Initial Response Phase</p> <p>The initial response phase will be accomplished using installed equipment. Licensees should establish and maintain current estimates of their capabilities to maintain core and SFP cooling and containment functions assuming a loss of alternate current (ac) electric power to the essential and nonessential switchgear buses except for those fed by station batteries through inverters. This estimate provides the time period in which the licensee should be able to initiate the transition phase and maintain or restore the key safety functions using portable onsite equipment. This estimate should be considered in selecting the storage locations for that equipment and the prioritization of resources to initiate their use.</p>	<p>The APR1400 FLEX strategy complies with the guidance. FLEX strategy for power operation and shutdown mode with SGs available: Initial phase: During the initial response phase, it is assumed that all ac power and normal access to UHS are lost, but the dc battery is available. Train C and D Class 1E battery supplies dc power to essential I&C equipment, and TDAFWPs continue to feed SGs at least for 8 hours following the event. Also, the steam generated from SG is released through the passive safety valves, MSSVs. Therefore, NCC operation to maintain RCS at hot standby is possible without any operator action during this phase.</p>

Table 5-7 Conformance with JLD-ISG-2012-01, Rev. 0 (2 of 5)

JLD-ISG-2012-01 Rev. 0		APR1400
Section	Summary	
		<p>FLEX strategy for shutdown mode with SGs not available: Initial phase: Decay heat is removed by RCS inventory boiloff from core.</p>
2.2	<p>Transition Phase</p>	<p>The transition phase will be accomplished using portable equipment stored onsite. The strategies for this phase must be capable of maintaining core cooling, containment, and spent fuel pool cooling capabilities (following their restoration, if applicable) from the time they are implemented until they can be supplemented by offsite resources in the final phase. The duration of the transition phase should provide sufficient overlap with both the initial and final phases to account for the time it takes to install equipment and for uncertainties.</p> <p>The APR1400 FLEX strategy complies with the guidance. FLEX strategy for power operation and shutdown mode with SGs available: Transition phase: During this phase, RCS is cooled down to around 176.67 °C (350 °F) using the installed plant equipment, such as TDAFWP, MSADV, ACP, SIT, and/or FLEX equipment, such as 480 V mobile GTG and primary FLEX pump. If installed plant equipment is inoperable even after connection of mobile ac power, RCS is further cooled down to around 98.89 °C (210 °F) using secondary side FLEX pump. RCS makeup is carried by the primary side FLEX pump. AFWST and RWT are consecutively used as onsite water sources to feed SGs. The transition phase can be extended to approximately 11 days. Therefore, the duration of the transition phase provides sufficient overlap with final phase. The initial phase overlaps for at least 8 hours with the transition phase, since dc battery is available until 16 hours following the event without load shedding.</p> <p>FLEX strategy for shutdown mode with SGs not available: Transition phase: The plant is maintained at cold shutdown by the RCS feed-and-bleed operation using the primary side low-head FLEX pump</p>

Table 5-7 Conformance with JLD-ISG-2012-01, Rev. 0 (3 of 5)

JLD-ISG-2012-01 Rev. 0		APR1400
Section	Summary	
2.3	Final Phase The final phase will be accomplished using the portable equipment stored onsite augmented with additional equipment and consumables obtained from offsite.	The APR1400 FLEX strategy complies with the guidance. Final phase: 4.16 kV mobile GTG is connected to Train A or Train B Class 1E switchgear. Consumables such as cooling water and GTG fuel are supplied from offsite for long-term coping with the event.
3.0	Core Cooling Strategies The first set of strategies necessary to meet the requirements of Order EA-12-049 addresses challenges to core cooling. Core cooling must be accomplished in all three phases described in the Order. The purpose of these strategies is to provide a means of cooling the core in order to prevent fuel damage.	The APR1400 FLEX strategy complies with the guidance. Supporting analysis for the operational strategy for core cooling were performed using RELAP5/Mod 3.3. It was shown from the analysis that even in the ELAP concurrent with LUHS, the plant is maintained at safe shutdown state (hot standby, hot shutdown, or cold shutdown, depending on the phase of the APR1400 core cooling FLEX strategy) without fuel damage.
4.0	Spent Fuel Pool Cooling Strategies The second set of strategies necessary to meet the requirements of Order EA-12-049 addresses challenges to SFP cooling. SFP cooling must be accomplished in all three phases described in the Order. The purpose of these strategies is to provide alternate means of cooling the spent fuel in order to prevent fuel damage. Licensees must consider all loading conditions relevant to their SFP, including a maximum core offload.	The APR1400 FLEX strategy complies with this guidance. Alternate means for supplying both makeup water to the SFP and spray water are provided from the outside of the auxiliary building. Maximum core offload condition was considered in the SFP boiloff analysis.
5.0	Containment Function Strategies The third group of strategies and guidance necessary to meet the requirements of Order EA-12-049 addresses challenges to the containment functions. Containment functions must be accomplished in all three phases described in the Order.	Upon loss of all ac power, all containment penetrations are isolated by either using dc power or mobile ac power. Also, for those penetrations needed to be opened for FLEX strategies, the isolation valves (SI-601, IW-005, IW-006, and CS-1013) can be opened by manual operation.

Table 5-7 Conformance with JLD-ISG-2012-01, Rev. 0 (4 of 5)

JLD-ISG-2012-01 Rev. 0		APR1400
Section	Summary	
5.1	<p>Removal of Heat from Containment (Pressure Control)</p> <p>Beyond-design-basis external events such as a prolonged SBO or loss of normal access to the ultimate heat sink could result in a long-term loss of containment heat removal. The goal of this strategy is to relieve pressure from the containment in such an event.</p>	<p>The APR1400 FLEX strategy complies with this guidance. The containment pressure and temperature can be maintained below the design basis value since the only source of energy imparted onto the containment building is the RCP seal leakage, which is 94.64 L/min (25 gpm) / RCP (a total of 378.54 L/min [100 gpm]). This is well below the mass and energy of the design basis accident, and the containment integrity can be maintained for the BDBEE conditions.</p>
6.0	<p>Programmatic Controls</p>	
6.1	<p>Equipment Protection, Storage, and Deployment</p> <p>Storage locations chosen for the equipment must provide protection from external events as necessary to allow the equipment to perform its function without loss of capability. In addition, the licensee must provide a means to bring the equipment to the connection point under those conditions in time to initiate the strategy prior to expiration of the estimated capability to maintain core and spent fuel pool cooling and containment functions in the initial response phase. Staff Position: NEI 12-06 provides an acceptable method to provide reasonable protection, storage, and deployment of the equipment associated with Order EA-12-049.</p>	<p>COL applicant is responsible for the FLEX equipment protection, storage, and deployment.</p>

Table 5-7 Conformance with JLD-ISG-2012-01, Rev. 0 (5 of 5)

JLD-ISG-2012-01 Rev. 0		APR1400
Section	Summary	
6.2	<p>Equipment Quality</p> <p>Staff Position: NEI 12-06 provides an acceptable method to control the quality of equipment associated with Order EA-12-049 with the following clarifications.</p> <ol style="list-style-type: none"> 1. Installed structures, systems and components pursuant to 10 CFR 50.63(a) should continue to meet the augmented quality guidelines of Regulatory Guide 1.155, "Station Blackout." 2. Development of maintenance and testing programs for the portable equipment responsive to Order EA-12-049, following the guidelines of NEI 12-06 and standard industry processes for ensuring equipment reliability, provides an acceptable method to reasonably assure the equipment will be functional. 3. In the absence of consensus standards specifically developed for these mitigating strategies, a licensee's conformance to consensus standards developed for similar emergency uses, such as those of the National Fire Protection Association for fire protection equipment, provides an acceptable method to reasonably assure the equipment will be functional. 	COL applicant is responsible for the FLEX equipment quality assurance.
7.0	<p>Guidance for AP1000 Design</p> <p>Appendix F of NEI 12-06 provides specific guidance for licensees with reactors of the AP1000 design on how to satisfy provisions of Order EA-12-049, Attachment 3, for the final phase (for sufficient offsite resources to sustain functions indefinitely).</p>	Not applicable to the APR1400

Table 5-8 Conformance with NEI 12-06, Rev. 0 (1 of 20)

NEI 12-06, Rev. 0		APR1400
Section	Summary	
1.0	Introduction	Not a requirement.
1.1	Background	
1.2	Purpose	
1.3	Objectives and Guiding Principles	<p>The APR1400 FLEX strategy complies with the guidance.</p> <p>The APR1400 FLEX strategy to cope with simultaneous occurrence of ELAP and LUHS has been developed to establish an indefinite coping capability to prevent damage to the fuel in the reactor and spent fuel pools and to maintain the containment function by using installed equipment, onsite FLEX equipment, and offsite resources.</p> <p>It follows the three-phase approach as guided by NEI-12-06. The three-phase operations consist of an initial response phase using installed equipment, a transition phase using FLEX equipment and consumables to provide core cooling, and a third phase of indefinite sustainment of these functions using offsite resources.</p> <p>The duration of phase 1 and 2 has been justified by support analysis considering the onsite availability of equipment, onsite resources.</p> <p>In the final phase, the 4.16 kV mobile GTG is brought to the site and used to restore the safety system such as SCS. Consumables such as cooling water and GTG fuel are assumed to be supplied from offsite for long-term coping with the event.</p>

Table 5-8 Conformance with NEI 12-06, Rev. 0 (2 of 20)

NEI 12-06, Rev. 0		APR1400
Section	Summary	
		<p>To the extent practical, generic thermal hydraulic analyses will be developed to support plant-specific decision-making. Justification for the duration of each phase will address the onsite availability of equipment, the resources necessary to deploy the equipment consistent with the required timeline, anticipated site conditions following the beyond-design-basis external event, and the ability of the local infrastructure to enable delivery of equipment and resources from offsite.</p>
1.4	Relationship to Other Tier 1 Requirements	Site-specific procedure to bring offsite resources will be prepared by COL applicants.
1.5	Applicability	<p>This guidance document is applicable to operating reactors, construction permit holders, and COL holders and addresses the development of mitigation strategies for beyond-design-basis external events.</p> <p>This guidance is applied to the APR1400 design certification except for the provisions for which COL applicants are responsible.</p>
2.0	Overview of Implementation Process	<p>FLEX strategies will be determined based on two criteria. Each plant will establish the ability to cope with the baseline conditions for a simultaneous ELAP and LUHS event. Each plant would then evaluate the FLEX protection and deployment strategies in consideration of the challenges of the external hazards applicable to the site. Depending on the challenge presented, the approach and specific implementation strategy may vary.</p> <p>Each plant and site has unique features and for this reason, the implementation of FLEX capabilities will be site-specific. This guideline is organized around the site assessment process shown in Figure 2-1. The guidance is provided to outline the steps, considerations, and ultimate FLEX strategies that are to be provided for each site.</p> <p>The COL applicants are responsible to finalize the FLEX protection and deployment strategies in consideration of the site-specific external hazards.</p>
2.1	Establish Baseline Coping Capability	<p>The first step of FLEX capability development is the establishment of the baseline coping capability to address a simultaneous ELAP and LUHS event. In general, the baseline coping capability is established based on an assumed set of boundary conditions that arise from a beyond-design-basis external event. Each plant will establish the ability to cope for</p> <p>The APR1400 FLEX strategy complies with the guidance.</p>

Table 5-8 Conformance with NEI 12-06, Rev. 0 (3 of 20)

NEI 12-06, Rev. 0		APR1400
Section	Summary	
	these baseline conditions using a combination of installed, temporary, and offsite equipment. These capabilities will also improve the ability of each plant to respond to other causes of a simultaneous ELAP and LUHS not specifically the result of an external event.	
2.2	<p>Determine Applicable External Hazards</p> <p>This step of the site assessment process involves the evaluation of the external hazards that are considered credible to a particular site. For the purposes of this assessment, external hazards have been grouped into five classes to help further focus the effort:</p> <ul style="list-style-type: none"> • seismic events • external flooding • storms such as hurricanes, high winds, and tornadoes • extreme snow, ice, and cold • extreme heat <p>Each plant will evaluate the applicability of these hazards and, where applicable, address the implementation considerations associated with each. These considerations include:</p> <ul style="list-style-type: none"> • protection of FLEX equipment • deployment of FLEX equipment • procedural interfaces • usation of offsite resources 	COL applicants are responsible to conduct the evaluation of the site-specific external hazards in accordance with the guidance.
2.3	<p>Define Site-Specific FLEX Strategies</p> <p>This step involves the consideration of the hazards that are applicable to the site, in order to establish the best overall strategy for the deployment of FLEX capabilities for beyond-design-basis conditions.</p> <p>Considering the external hazards applicable to the site, the FLEX mitigation equipment should be stored in a location or locations such that it is reasonably protected such that no one external event can reasonably fail the site FLEX capability. Reasonable protection can be provided for example, through provision of multiple sets of portable onsite equipment stored in diverse locations or through storage in structures designed to reasonably protect from applicable external events.</p> <p>The process for defining the full extent of the FLEX coping capability is described in Section 10.</p>	COL applicants are responsible to define the site-specific FLEX strategies.

Table 5-8 Conformance with NEI 12-06, Rev. 0 (4 of 20)

NEI 12-06, Rev. 0		APR1400
Section	Summary	
2.4	<p>Programmatic Controls</p> <p>The programmatic controls for implementation of FLEX include:</p> <ul style="list-style-type: none"> • quality attributes • equipment design • equipment storage • procedure guidance • maintenance and testing • training • staffing • configuration control <p>Procedures and guidance to support deployment and implementation including interfaces to EOPs, special event procedures, abnormal event procedures, and system operating procedures, will be coordinated within the site procedural framework.</p>	<p>COL applicants are responsible to establish the programmatic controls for implementation of FLEX and to coordinate them within the site procedural framework.</p>
2.5	<p>Synchronization with Offsite Resources</p> <p>The timely provision of effective offsite resources will need to be coordinated by the site and will depend on the plant-specific analysis and strategies for coping with the effects of the beyond-design-basis external event. Arrangements will need to be established by each site for the offsite equipment and resources that will be required for the offsite phase. The offsite response interfaces for FLEX capabilities are described in Section 12.</p>	<p>COL applicants are responsible to arrange the offsite equipment and resources that required for the offsite phase based on the APR1400 FLEX strategies.</p>
3.2	<p>Performance Attributes</p> <p>See below.</p>	
3.2.1	<p>General Criteria and Baseline Assumptions</p> <p>See below.</p>	
3.2.1.1	<p>General Criteria</p> <p>Procedures and equipment relied upon should ensure that satisfactory performance of necessary fuel cooling and containment functions are maintained. A simultaneous ELAP and LUHS challenges both core cooling and spent fuel pool cooling due to interruption of normal ac powered system operations.</p> <p>For a PWR, an additional requirement is to keep the fuel in the reactor covered. For both PWRs and BWRs, the requirement is to keep fuel in the spent fuel pool covered.</p>	<p>The APR1400 FLEX strategy complies with the guidance in terms of the criteria "maintain fuel cooling," "maintain containment function," and "keep fuel in the spent fuel pool covered." However, the criterion "no fuel failure" is used instead of the guidance "keep the fuel in the reactor covered," because the mixture level in the reactor is not clearly defined in the supporting analysis using RELAP5. Instead of calculating the mixture level, the core</p>

Table 5-8 Conformance with NEI 12-06, Rev. 0 (5 of 20)

NEI 12-06, Rev. 0		APR1400	
Section	Summary		
	The conditions considered herein are beyond-design-basis. Consequently, it is not possible to bind all essential inputs to these evaluations.	cooling capability is ensured by the fuel heat-up analysis which directly calculates the fuel temperature.	
3.2.1.2	Initial Plant Conditions	<p>(1) Prior to the event the reactor has been operating at 100 percent rated thermal power for at least 100 days or has just been shut down from such a power history as required by plant procedures in advance of the impending event.</p> <p>(2) At the time of the postulated event, the reactor and supporting systems are within normal operating ranges for pressure, temperature, and water level for the appropriate plant condition. All plant equipment is either normally operating or available from the standby state as described in the plant design and licensing basis.</p>	The APR1400 FLEX strategy complies with the guidance.
3.2.1.3	Initial Conditions	<p>(1) No specific initiating event is used. The initial condition is assumed to be a loss of offsite power (LOOP) at a plant site resulting from an external event that affects the offsite power system either throughout the grid or at the plant with no prospect for recovery of offsite power for an extended period. The LOOP is assumed to affect all units at a plant site.</p> <p>(2) All installed sources of emergency onsite ac power and SBO Alternate ac power sources are assumed to be not available and not imminently recoverable.</p> <p>(3) Cooling and makeup water inventories contained in systems or structures with designs that are robust with respect to seismic events, floods, and high winds, and associated missiles are available.</p> <p>(4) Normal access to the ultimate heat sink is lost, but the water inventory in the UHS remains available and robust piping connecting the UHS to plant systems remains intact. The motive force for UHS flow, i.e., pumps, is assumed to be lost with no prospect for recovery.</p> <p>(5) Fuel for FLEX equipment stored in structures with designs which are robust with respect to seismic events, floods and high winds and associated missiles, remains available.</p>	The APR1400 FLEX strategy complies with the guidance.

Table 5-8 Conformance with NEI 12-06, Rev. 0 (6 of 20)

NEI 12-06, Rev. 0		APR1400
Section	Summary	
	<p>(6) Permanent plant equipment that is contained in structures with designs that are robust with respect to seismic events, floods, and high winds, and associated missiles, are available.</p> <p>(7) Other equipment, such as portable ac power sources, portable back up dc power supplies, spare batteries, and equipment for 50.54(hh)(2), may be used provided it is reasonably protected from the applicable external hazards per Sections 5 through 9 and Section 11.3 of this guidance and has predetermined hookup strategies with appropriate procedures/guidance and the equipment is stored in a relative close vicinity of the site.</p> <p>(8) Installed electrical distribution system, including inverters and battery chargers, remain available provided they are protected consistent with current station design.</p> <p>(9) No additional events or failures are assumed to occur immediately prior to or during the event, including security events.</p> <p>(10) Reliance on the fire protection system ring header as a water source is acceptable only if the header meets the criteria to be considered robust with respect to seismic events, floods, and high winds, and associated missiles.</p>	
3.2.1.4	<p>Reactor Transient</p> <p>Additional boundary conditions:</p> <p>(1) Following the loss of all ac power, the reactor automatically trips and all rods are inserted.</p> <p>(2) The main steam system valves (such as main steam isolation valves, turbine stops, atmospheric dumps, etc.), necessary to maintain decay heat removal functions operate as designed.</p> <p>(3) Safety/Relief Valves (S/RVs) or Power Operated Relief Valves (PORVs) initially operate in a normal manner if conditions in the RCS so require. Normal valve reseating is also assumed.</p> <p>(4) No independent failures, other than those causing the ELAP/LUHS event, are assumed to occur in the course of the transient.</p>	The APR1400 FLEX strategy complies with the guidance.

Table 5-8 Conformance with NEI 12-06, Rev. 0 (7 of 20)

		NEI 12-06, Rev. 0	APR1400
Section	Summary		
3.2.1.5	Reactor Coolant Inventory Loss	Sources of expected PWR reactor coolant inventory loss include: (1) normal system leakage (2) losses from letdown unless automatically isolated or until isolation is procedurally directed (3) losses due to reactor coolant pump seal leakage (rate is dependent on the RCP seal design)	The APR1400 FLEX strategy complies with the guidance. During normal operation, there is the controlled bleed-off of 12.11 L/min (3.2 gpm) through each RCP, which is compensated by charging flow. RCP seal leakage might progress from the controlled bleed-off of 12.11 L/min (3.2 gpm) per RCP to around 75.71 L/min (20 gpm) per RCP at 158.19 kg/cm ² A (2,250 psia) after 30 minutes. Other normal system leakages, i.e., identified leakage of 10 gpm and unidentified leakage of 0.5 gpm, are allowed in APR1400 technical specification. Normal letdown flow is 302.83 L/min (80 gpm), but letdown isolation valve is designed to close at setpoint of PZR low pressure. The letdown isolation valve could be also closed by operator action within 30 minutes following the event. In the support analysis for the APR1400 FLEX strategy, the seal leakage from each RCP is assumed to be 94.64 L/min (25 gpm) from the beginning of the event. Therefore, the assumption of seal leakage is conservatively determined to include all of system leakages considered above.
3.2.1.6	SFP Conditions	Initial conditions: (1) All boundaries of the SFP are intact, including the liner, gates, transfer canals, etc. (2) Although sloshing may occur during a seismic event, the initial loss of SFP inventory does not preclude access to the refueling deck around the pool. (3) SFP cooling system is intact, including attached piping. (4) SFP heat load assumes the maximum design basis heat load for the site.	The APR1400 FLEX strategy complies with the guidance.
3.2.1.7	Event Response Actions	Event response actions follow the command and control of the existing procedures and guidance based on the underlying symptoms that result from the event.	The APR1400 FLEX strategy complies with the guidance.

Table 5-8 Conformance with NEI 12-06, Rev. 0 (8 of 20)

NEI 12-06, Rev. 0		APR1400	
Section	Summary		
	<p>The priority for the plant response is to utilize systems or equipment that provides the highest probability for success. Other site impacts as a result of the event would be addressed according to plant priorities and resource availability. The FLEX strategy relies upon the following principles:</p> <ol style="list-style-type: none"> 1) Initially cope by relying on installed plant equipment. 2) Transition from installed plant equipment to onsite FLEX equipment. 3) Obtain additional capability and redundancy from offsite resources until power, water, and coolant injection systems are restored or commissioned. 4) Response actions will be prioritized based on available equipment, resources, and time constraints. The initial coping response actions can be performed by available site personnel post-event. 5) Transition from installed plant equipment to onsite FLEX equipment may involve onsite, offsite, or recalled personnel as justified by plant-specific evaluation. 6) Strategies that have a time constraint to be successful should be identified and a basis provided that the time can reasonably be met. 		
3.2.1.8	Effects of Loss of Ventilations	The effects of loss of HVAC in an extended loss of ac power event can be addressed consistent with NUMARC 87-00 [Ref. 8] or by plant-specific thermal hydraulic calculations, e.g., GOTHIC calculations.	The APR1400 FLEX strategy complies with the guidance.
3.2.1.9	Personnel Accessibility	Areas requiring personnel access should be evaluated to ensure that conditions will support the actions required by the plant-specific strategy for responding to the event.	The APR1400 FLEX strategy complies with the guidance. The connections for primary and secondary FLEX pumps, and mobile GTGs, are provided on the outside of the exterior wall of the auxiliary building, thereby providing reasonable assurance of the accessibility of personnel and equipment.
3.2.1.10	Instrumentation and Controls	Actions specified in plant procedures/guidance for loss of ac power are predicated on use of instrumentation and controls powered by station batteries. In order to extend battery life, a	The APR1400 FLEX strategy complies with the guidance.

Table 5-8 Conformance with NEI 12-06, Rev. 0 (9 of 20)

NEI 12-06, Rev. 0		APR1400
Section	Summary	
	<p>minimum set of parameters necessary to support strategy implementation should be defined. The parameters selected must be able to demonstrate the success of the strategies at maintaining the key safety functions as well as indicate imminent or actual core damage to facilitate a decision to manage the response to the event within the Emergency Operating Procedures and FLEX Support Guidelines or within the SAMGs. Typically, these parameters would include the following:</p> <ul style="list-style-type: none"> • SG Level • SG Pressure • RCS Pressure • RCS Temperature • Containment Pressure • SFP Level 	<p>Operator actions defined in the coping strategy for a simultaneous ELAP and LUHS are predicated on use of instrumentation and controls powered by the dc battery, which is available for 16 hours without load shedding and 40 hours with load shedding started at 8 hours.</p> <p>The essential parameters for operator actions include:</p> <ul style="list-style-type: none"> • SG level • SG pressure • PZR pressure • Hot leg temperature • Cold leg temperature • Containment pressure • SFP level
3.2.1.11	<p>Containment Isolation Valves</p> <p>It is assumed that the containment isolation actions delineated in current station blackout coping capabilities is sufficient.</p>	<p>The APR1400 FLEX strategy complies with the guidance. See response to Section 5.0 of Table 5-8.</p>
3.2.2	<p>Minimum Baseline Capabilities</p> <p>Each site should establish the minimum coping capabilities consistent with unit-specific evaluation of the potential impacts and responses to an ELAP and LUHS. In general, this coping can be thought of as occurring in three phases:</p> <ul style="list-style-type: none"> • Phase 1: Cope relying on installed plant equipment. • Phase 2: Transition from installed plant equipment to onsite FLEX equipment. • Phase 3: Obtain additional capability and redundancy from offsite equipment until power, water, and coolant injection systems are restored or commissioned. <p>In order to support the objective of an indefinite coping capability, each plant will be expected to establish capabilities consistent with Table 3-2 (PWRs). The following guidelines are provided to support the development of guidance to cope with the existing set of plant operating procedures/guidance:</p>	<p>COL applicants are responsible to develop plant-specific procedures based on the APR1400 FLEX strategy, considering the guidance in NEI 12-06.</p>

Table 5-8 Conformance with NEI 12-06, Rev. 0 (10 of 20)

NEI 12-06, Rev. 0		APR1400
Section	Summary	
	<p>(1) Plant procedures/guidance should identify site-specific actions necessary to restore ac power to essential loads. If an Alternate ac (AAC) power source is available it should be started as soon as possible. If not, actions should be taken to secure existing equipment alignments and provide an alternate power source as soon as possible based on relative plant priorities.</p> <p>(2) Plant procedures/guidance should recognize the importance of AFW/HPCI/RCIC/IC during the early stages of the event and direct the operators to invest appropriate attention to assuring its initiation and continued, reliable operation throughout the transient since this provides reasonable assurance decay heat removal.</p> <p>(3) Plant procedures/guidance should specify actions necessary to assure that equipment functionality can be maintained (including support systems or alternate method) in an ELAP/LUHS or can perform without ac power or normal access to the UHS.</p> <p>(4) Plant procedures/guidance should identify the sources of potential reactor inventory loss, and specify actions to prevent or limit significant loss.</p> <p>(5) Plant procedures/guidance should ensure that a flow path is promptly established for makeup flow to the steam generator/nuclear boiler and identify backup water sources in order of intended use. Additionally, plant procedures/guidance should specify clear criteria for transferring to the next preferred source of water.</p> <p>(6) Plant procedures/guidance should identify loads that need to be stripped from the plant dc buses (both Class 1E and non-Class 1E) for the purpose of conserving dc power.</p> <p>(7) Plant procedures/guidance should specify actions to permit appropriate containment isolation and safe shutdown valve operations while ac power is unavailable.</p>	

Table 5-8 Conformance with NEI 12-06, Rev. 0 (11 of 20)

NEI 12-06, Rev. 0		APR1400
Section	Summary	
	<p>(8) Plant procedures/guidance should identify the portable lighting (e.g., flashlights or headlamps) and communications systems necessary for ingress and egress to plant areas required for deployment of FLEX strategies.</p> <p>(9) Plant procedures/guidance should consider the effects of ac power loss on area access, as well as the need to gain entry to the Protected Area and internal locked areas where remote equipment operation is necessary.</p> <p>(10) Plant procedures/guidance should consider loss of ventilation effects on specific energized equipment necessary for shutdown (e.g., those containing internal electrical power supplies or other local heat sources that may be energized or present in an ELAP.</p> <p>(11) Plant procedures/guidance should consider accessibility requirements at locations where operators will be required to perform local manual operations.</p> <p>(12) Plant procedures/guidance should consider loss of heat tracing effects for equipment required to cope with an ELAP. Alternate steps, if needed, should be identified to supplement planned action.</p> <p>(13) Use of portable equipment, e.g., portable power supplies, portable pumps, etc., can extend plant coping capability. The procedures/guidance for implementation of these portable systems should address the transitions from installed sources to portable are available as well as to address delivery capabilities.</p> <p>(14) Procedures/guidance should address the appropriate monitoring and makeup options to the SFP.</p>	
3.3	Consideration in Utilizing Off-Site Resources	COL applicants are responsible to comply with the guidance.

Table 5-8 Conformance with NEI 12-06, Rev. 0 (12 of 20)

NEI 12-06, Rev. 0		APR1400	
Section	Summary		
	<p>The site will need to identify staging area(s) for receipt of the equipment and a means to transport the offsite equipment to the deployment location.</p> <p>It is expected that the licensee will ensure the offsite resource organization will be able to provide the resources that will be necessary to support the extended coping duration. A list of possible offsite equipment is provided in Section 12.</p> <p>In addition, the licensee will need to ensure standard connectors for electrical and mechanical equipment compatible with the site connections are provided.</p>		
4	<p>STEP 2: Determine Applicable Extreme External Hazards</p>	See below.	
5	<p>STEP 2A: Assess Seismic Impact</p>	<p>The FLEX deployment strategy will address seismic hazards at all sites.</p>	COL applicant is responsible for the site-specific seismic hazards assessment.
6	<p>STEP 2B: Assess External Flooding Impact</p>	<p>The potential challenge presented by external flooding is very site-specific and is a function of the site layout, plant design, and potential external flooding hazards present. Typically, plant design bases address the following hazards:</p> <ul style="list-style-type: none"> • local intense precipitation • flooding from nearby rivers, lakes, and reservoirs • high tides • seiche • hurricane and storm surge • tsunami events. 	COL applicant is responsible for the site-specific flooding assessment.
7	<p>STEP 2C: Assess Impact of Severe Storms with High Winds</p>	<p>The evaluation of high wind-induced challenges has three parts. The first part is determining whether the site is potentially susceptible to different high wind conditions. The second part is the characterization of the applicable high wind threat. The third part is the application of the high wind threat characterization to the protection and deployment of FLEX strategies.</p>	COL applicant is responsible for the site-specific high-wind assessment.

Table 5-8 Conformance with NEI 12-06, Rev. 0 (13 of 20)

NEI 12-06, Rev. 0			APR1400
Section	Summary		
8	STEP 2D: Assess Impact of Snow, Ice and Extreme Cold	All sites should consider the temperature ranges and weather conditions for their site in storing and deploying their FLEX equipment.	COL applicant is responsible for the site-specific snow, ice, and extreme cold condition assessment.
9	STEP 2E: Assess Impact of High Temperatures	All sites will address high temperatures.	COL applicant is responsible for the site-specific high-temperature assessment.
10	STEP 3: Define Site-Specific FLEX Capabilities	This step involves the consideration of the aggregate set of onsite and offsite resource considerations for the hazards that are applicable to the site. That is, the site should aggregate all of the considerations related to: <ul style="list-style-type: none"> • protection of FLEX equipment • deployment of FLEX equipment • procedural interfaces • usation of offsite resources In order to establish the best overall strategy for the storage and deployment of FLEX capabilities over a broad set of beyond-design-basis conditions an aggregated assessment is needed of the site-specific considerations identified for the applicable hazards.	COL applicant is responsible for the site-specific aggregated assessment of the FLEX capabilities.
11	Programmatic Controls		
11.1	Quality Attributes	Equipment associated with these strategies will be procured as commercial equipment with design, storage, maintenance, testing, and configuration control as outlined in this section. If the equipment is credited for other functions (e.g., fire protection), then the quality attributes of the other functions apply.	COL applicants are responsible to determine quality attributes of FLEX equipment.
11.2	Equipment Design	1. Design requirements and supporting analysis should be developed for portable equipment that directly performs a FLEX mitigation strategy for core, containment, and SFP that provides the inputs, assumptions, and documented analysis that the mitigation strategy and support equipment will perform as	Requirement for major design parameters of FLEX equipment such as capacity and voltage of 480 V mobile GTGs, and head and flow of FLEX pumps have been determined, based on the support analysis.

Table 5-8 Conformance with NEI 12-06, Rev. 0 (14 of 20)

NEI 12-06, Rev. 0		APR1400
Section	Summary	
	<p>intended. When specifying portable equipment, the capacities should ensure that the strategy can be effective over a range of plant and environmental conditions. This documentation should be auditable, consistent with generally accepted engineering principles and practices, and controlled within the configuration document control system.</p> <p>2. Portable towable equipment that is designed for over the road transport typically used in construction/remote sites are deemed sufficiently rugged to function following a BDB seismic event.</p> <p>3. Note that the functionality of the equipment may be outside the manufacturer's specifications if justified in a documented engineering evaluation.</p> <p>4. It is desirable for diverse mitigation equipment to be commonly available (e.g., commercial equipment) such that parts and replacements can be readily obtained.</p>	<p>COL applicants are responsible to determine site-specific design requirement for FLEX equipment that directly performs the FLEX mitigation.</p>
11.3	<p>Equipment Storage</p> <p>1. Detailed guidance for selecting suitable storage locations that provide reasonable protection during specific external events is provided in Sections 5 through 9.</p> <p>2. A technical basis should be developed for equipment storage for portable equipment that directly performs a FLEX mitigation strategy for core, containment, and SFP that provides the inputs, assumptions, and documented basis that the mitigation strategy and support equipment will be reasonably protected from applicable external events such that the equipment could be operated in place, if applicable, or moved to its deployment locations. This basis should be auditable, consistent with generally accepted engineering principles, and controlled within the configuration document control system.</p> <p>3. FLEX mitigation equipment should be stored in a location or locations informed by evaluations performed per Sections 5 through 9 such that no one external event can reasonably fail the site FLEX capability.</p>	<p>COL applicant is responsible for equipment storage.</p>

Table 5-8 Conformance with NEI 12-06, Rev. 0 (15 of 20)

NEI 12-06, Rev. 0		APR1400
Section	Summary	
	<p>4. Different FLEX equipment can be credited for independent events.</p> <p>5. Consideration should be given to the transport from the storage area following the external event recognizing that external events can result in obstacles restricting normal pathways for movement.</p> <p>6. If portable FLEX equipment is pre-staged such that it minimizes the time delay and burden of hook-up following an external event, then the equipment should be evaluated to not have an adverse effect on existing SSCs and the primary connection point should be as close to the intended point of supply as possible, e.g., a staged power supply to recharge batteries should be connected as close to the battery charger as practicable to maintain diversity and minimize the reliance on other installed equipment.</p> <p>7. FLEX equipment should be stored and maintained in a manner that is consistent with assuring that it does not degrade over long periods of storage and that it is accessible for periodic maintenance and testing.</p> <p>8. If 50.54(hh)(2) equipment is credited in the FLEX mitigating strategies, it should meet the above storage requirements in addition to the 50.54(hh)(2) requirements.</p> <p>9. If debris removal equipment is needed, it should be reasonably protected from the applicable external events such that it is likely to remain functional and deployable to clear obstructions from the pathway between the FLEX equipment's storage location and its deployment location(s).</p> <p>10. Deployment of the FLEX equipment or debris removal equipment from storage locations should not depend on offsite power or onsite emergency ac power (e.g., to operate roll up doors, lifts, elevators, etc.).</p>	
11.4	Procedure Guidance	

Table 5-8 Conformance with NEI 12-06, Rev. 0 (16 of 20)

NEI 12-06, Rev. 0		APR1400
Section	Summary	
11.4.1	Objectives	Not a requirement
11.4.2	Operating Procedure Hierarchy	COL applicants are responsible to organize operating procedure hierarchy.
11.4.3	Development Guidance for FSGs	COL applicants are responsible to develop EOP and FSG that can be employed for a variety of conditions.
11.4.4	Regulatory Screening/ Evaluations	COL applicants are responsible to develop EOP and FSG.

Table 5-8 Conformance with NEI 12-06, Rev. 0 (17 of 20)

		NEI 12-06, Rev. 0	APR1400
Section	Summary		
11.5	Maintenance and Testing	<p>1. FLEX mitigation equipment should be initially tested or other reasonable means used to verify performance conforms to the limiting FLEX requirements. Validation of source manufacturer quality is not required.</p> <p>2. Portable equipment that directly performs a FLEX mitigation strategy for the core, containment, or SFP should be subject to maintenance and testing guidance provided in INPO AP 913, Equipment Reliability Process, to verify proper function. The maintenance program should ensure that the FLEX equipment reliability is being achieved. Standard industry templates (e.g., EPRI) and associated bases will be developed to define specific maintenance and testing.</p> <p>3. The unavailability of equipment and applicable connections that directly performs a FLEX mitigation strategy for core, containment, and SFP should be managed such that risk to mitigating strategy capability is minimized.</p>	COL applicants are responsible for maintenance and test of FLEX equipment.
11.6	Training	<p>1. Programs and controls should be established to assure personnel proficiency in the mitigation of beyond-design-basis events is developed and maintained. These programs and controls should be implemented in accordance with an accepted training process.</p> <p>2. Periodic training should be provided to site emergency response leaders on beyond-design-basis emergency response strategies and implementing guidelines. Operator training for beyond-design-basis event accident mitigation should not be given undue weight in comparison with other training requirements. The testing/evaluation of Operator knowledge and skills in this area should be similarly weighted.</p> <p>3. Personnel assigned to direct the execution of mitigation strategies for beyond-design-basis events will receive necessary training to ensure familiarity with the associated tasks, considering available job aids, instructions, and mitigating strategy time constraints.</p>	COL applicants are responsible for training program and controls.

Table 5-8 Conformance with NEI 12-06, Rev. 0 (18 of 20)

NEI 12-06, Rev. 0		APR1400
Section	Summary	
	<p>4. "ANSI/ANS 3.5, Nuclear Power Plant Simulators for use in Operator Training" certification of simulator fidelity (if used) is considered to be sufficient for the initial stages of the beyond-design-basis external event scenario until the current capability of the simulator model is exceeded. Full scope simulator models will not be upgraded to accommodate FLEX training or drills.</p> <p>5. Where appropriate, the integrated FLEX drills should be organized on a team or crew basis and conducted periodically; with all time-sensitive actions to be evaluated over a period of not more than eight years. It is not the intent to connect to or operate permanently installed equipment during these drills and demonstrations.</p>	
11.7	Staffing	COL applicants are responsible for onsite staffing.
	<p>1. Onsite staff are at site administrative minimum shift staffing levels, (minimum staffing may include additional staffing that is procedurally brought onsite in advance of a predicted external event, e.g., hurricane).</p> <p>2. No independent, concurrent events, e.g., no active security threat, and</p> <p>3. All personnel onsite are available to support site response.</p>	
11.8	Configuration Control	COL applicants are responsible for the plant configuration control.
	<p>1. The FLEX strategies and basis will be maintained in an overall program document. This program document will also contain a historical record of previous strategies and the basis for changes. The document will also contain the basis for the ongoing maintenance and testing programs chosen for the FLEX equipment.</p> <p>2. Existing plant configuration control procedures will be modified to ensure that changes to the plant design, physical plant layout, roads, buildings, and miscellaneous structures will not adversely impact the approved FLEX strategies.</p> <p>3. Changes to FLEX strategies may be made without prior NRC approval.</p>	
12	Off-Site Resources	

Table 5-8 Conformance with NEI 12-06, Rev. 0 (19 of 20)

NEI 12-06, Rev. 0		APR1400
Section	Summary	
12.1	Synchronization with Offsite Resources	Arrangements will need to be established by each site addressing the scope of equipment that will be required for the offsite phase, as well as the maintenance and delivery provisions for such equipment.
12.2	Minimum Capabilities of Offsite Resources	COL applicants are responsible to establish arrangement of offsite resources.
	<p>Each site will establish a means to ensure the necessary resources will be available from offsite. Considerations that should be included in establishing this capability include:</p> <ol style="list-style-type: none"> 1) A capability to obtain equipment and commodities to sustain and backup the site's coping strategies. 2) Offsite equipment procurement, maintenance, testing, calibration, storage, and control. 3) A provision to inspect and audit the contractual agreements to reasonably assure the capabilities to deploy the FLEX strategies including unannounced random inspections by the Nuclear Regulatory Commission. 4) Provisions to ensure that no single external event will preclude the capability to supply the needed resources to the plant site. 5) Provisions to ensure that the offsite capability can be maintained for the life of the plant. 6) Provisions to revise the required supplied equipment due to changes in the FLEX strategies or plant equipment or equipment obsolescence. 7) The appropriate standard mechanical and electrical connections need to be specified. 8) Provisions to ensure that the periodic maintenance, periodic maintenance schedule, testing, and calibration of offsite equipment are comparable/ consistent with that of similar onsite FLEX equipment. 9) Provisions to ensure that equipment determined to be unavailable/non-operational during maintenance or testing is either restored to operational status or replaced with appropriate alternate equipment within 90 days. 	COL applicants are responsible to establish a means to ensure the necessary resources are available from offsite.

Table 5-8 Conformance with NEI 12-06, Rev. 0 (20 of 20)

NEI 12-06, Rev. 0			APR1400
Section	Summary		
		10) Provision to ensure that reasonable supplies of spare parts for the offsite equipment are readily available if needed. The intent of this provision is to reduce the likelihood of extended equipment maintenance (requiring in excess of 90 days for returning the equipment to operational status).	
13	Submittal Guidance	Reporting requirements are established in accordance with NRC Order EA-12-049 Order Modifying Licenses with Regard to Requirements for Mitigation Strategies for Beyond-Design-Basis External Events.	NA

Table 5-9 Conformance with NEI 12-06, Rev. 0 – Tables D-1, D-2, and D-3 (1 of 4)

NEI 12-06, Rev. 0 – Tables D-1, D-2, and D-3			APR1400
Safety Function	Method	Performance Attributes	
Core Cooling and Heat Removal (SG available)	AFW/EFW	<ul style="list-style-type: none"> • Extend installed coping capability through procedural enhancements (e.g., load shedding), provision of portable battery chargers and other power supplies. • Objective is to provide extended baseline coping capability with installed equipment. • Procedures/guidance to include local manual initiation of ac-independent AFW/EFW pumps consistent with NEI 06-12. 	<ul style="list-style-type: none"> • Train C/D dc battery is available for 16 hours without load shedding, and 480 V mobile GTG is prepared to charge Train A or Train B dc battery and to supply ac power to the installed safety components such as ACP. • ac-independent FLEX pumps provide the safety functions such as core cooling and RCS makeup, according to the APR1400 FLEX strategy.
Core Cooling and Heat Removal (SG available)	Depressurize SG for makeup with portable injection source	<ul style="list-style-type: none"> • Primary and alternate injection points are required to establish capability to inject through separate divisions/trains, i.e., should not have both connections in one division/train. • Makeup paths supply required SGs. • SG makeup rate should exceed decay heat levels at time of planned deployment in order to support restoring SG water level, e.g., 200 gpm.⁽¹⁾ • Analysis should demonstrate that the guidance and equipment for combined SG depressurization and makeup capability support continued core cooling. 	<ul style="list-style-type: none"> • Rated flow of secondary FLEX pump is 1173.48 L/min (310 gpm), which is sufficient not only to remove decay heat but also to restore SG water level. • Supporting analysis for FLEX strategy shows that the APR1400 plant has capability for continued core cooling during ELAP concurrent with LUHS.
Core Cooling and Heat Removal (SG available)	Sustained source of water	<ul style="list-style-type: none"> • Water source sufficient to supply water indefinitely including consideration of concurrent makeup or spray of SFP 	<ul style="list-style-type: none"> • Onsite water sources such as AFWST and RWT provide water to feed SG for approximately 2 weeks. When RWT inventory is shared with the SFP cooling water, the water source can feed SG at least for 11 days.
RCS Inventory Control / Long-Term Subcriticality	Low-leakage RCP seals and/or borated high-pressure RCS makeup required	<ul style="list-style-type: none"> • Makeup capability to maintain core cooling⁽¹⁾ • Sufficient letdown to support required makeup and ensure subcriticality⁽¹⁾ 	<ul style="list-style-type: none"> • The APR1400 RCP adopts a three-stage seal design, which is similar to CE-KSB pump. • ACP provides RCS with borated water from IRSWT and BAST, after 480 V mobile GTG is connected. • SIT also provides RCS with borated water, when RCS pressure reduces to the setpoint during cooldown operation. • Primary FLEX pump is also able to make up RCS inventory with borated water in the long

Table 5-9 Conformance with NEI 12-06, Rev. 0 – Tables D-1, D-2, and D-3 (2 of 4)

NEI 12-06, Rev. 0 – Tables D-1, D-2, and D-3			APR1400
Safety Function	Method	Performance Attributes	
Core Cooling and Heat Removal (Modes 5 and 6, SG unavailable)	All plants provide means to provide borated RCS makeup ⁽²⁾	<ul style="list-style-type: none"> • Diverse injection points or methods are required to establish capability to inject through separate divisions/trains, i.e., should not have both connections in one division/train. • Connection to RCS for makeup should be capable of flow rates sufficient for simultaneous core heat removal and boron flushing (combined makeup flow exceeding 300 gpm). ⁽¹⁾ • Onsite pump (portable or installed) for RCS makeup. This can be the SG makeup pump since both will not be required at same time. • In order to address the requirement for diversity, if repowering of installed charging pumps is used for this function, then either (a) multiple power connection points should be provided to the charging pump, or (b) provide a single power supply connection point for the charging pump and a single connection point for a portable makeup pump. Source of borated water could be an onsite tank or could be provided by offsite resources. 	term. <ul style="list-style-type: none"> • ACP provides RCS with borated water from IRWST, after 480 V mobile GTG is connected. • Rated flow of the primary low-head FLEX pump is around 2,839 L/min (750 gpm), which is sufficient for core heat removal.
Key Reactor Parameters	<ul style="list-style-type: none"> • SG level • SG pressure • RCS pressure • RCS temperature 	<ul style="list-style-type: none"> • Identify instruments to be relied upon, including control room and field instruments. • Depending on strategy employed, additional parameters may be required. 	<ul style="list-style-type: none"> • Instruments for the following key plant parameters are available for operators to monitor plant condition and to carry out operator action according to the APR1400 FLEX strategy. <ul style="list-style-type: none"> - PZR pressure - PZR level - Hot leg temperature - Cold leg temperature - SG pressure - SG level - Charging flow - SIT level - SIT pressure - Etc.

Table 5-9 Conformance with NEI 12-06, Rev. 0 – Tables D-1, D-2, and D-3 (3 of 4)

NEI 12-06, Rev. 0 – Tables D-1, D-2, and D-3			APR1400
Safety Function	Method	Performance Attributes	
Containment Function	Containment spray	Due to the long-term nature of this function, the connection does not need to be a permanent modification. However, if a temporary connection is necessary, e.g., via valve bonnet, then this should be pre-identified.	The emergency containment spray backup system (ECSBS) is provided for long-term maintenance of containment function. The ECSBS is supplied water by FLEX pump through connections located outside the exterior wall of the auxiliary building.
Key Containment Parameters	Containment pressure	Identify instruments to be relied upon, including control room and field instruments.	The following containment pressure instruments are available in MCR for operators to monitor plant condition and carry out operator action according to the APR1400 FLEX strategy: <ul style="list-style-type: none"> - Containment pressure: high alarm indicator - Containment pressure: high-high alarm indicator
Spent Fuel Cooling	Makeup with portable injection source (makeup via hoses on refuel floor)	Minimum makeup rate must be capable of exceeding boiloff rate for the boundary conditions described in Subsection 3.2.1.6.	The APR1400 strategy complies with this guidance. The hose stations on the operating floor of the SFP area can provide the makeup capacity of 1,893 L/min (500 gpm), which exceeds the maximum boiloff rate (493.2 L/min [130.3 gpm]).
	Makeup with portable injection source (makeup via connection to SFP cooling piping or other alternate location)	Minimum makeup rate must be capable of exceeding boiloff rate for the boundary conditions described in Subsection 3.2.1.6.	The APR1400 strategy complies with this guidance. The FLEX makeup capacity (1,893 L/min [500 gpm]) exceeds the maximum boiloff rate (493.2 L/min [130.3 gpm]).
	Makeup with portable injection source (vent pathway for steam and condensate from SFP)	Plant-specific strategy should be considered as needed.	The rollup door at fuel handling area truck bay in the auxiliary building can be opened to provide a vent path for steam and condensate from SFP.

Table 5-9 Conformance with NEI 12-06, Rev. 0 – Tables D-1, D-2, and D-3 (4 of 4)

NEI 12-06, Rev. 0 – Tables D-1, D-2, and D-3			APR1400
Safety Function	Method	Performance Attributes	
	Makeup with portable injection source (spray capability via portable monitor nozzles from refueling floor using portable pump).	Minimum of 757 L/min (200 gpm) per unit to the pool or 946 L/min (250 gpm) per unit if overspray occurs consistent with 10 CFR 50.54(hh)(2). This capability is not required for sites that have SFPs that cannot be drained.	The spray makeup of at least 757 L/min (200 gpm) through diverse spray line of 10 cm (4 in) is available. Minimum of 757 L/min (200 gpm) is consistent with the guidance of NEI 06-12.
SFP Parameters	SFP level	Per EA 12-051	The APR1400 design includes redundant, safety-related wide-range level sensors in SFP that fulfill EA 12-051 order.

Notes:

- (1) Subject to generic or plant-specific analysis
- (2) There may be short periods of time during Modes 5 and 6 when plant configuration may preclude use of this strategy.

Table 5-10 Conformance with NEI 12-02, Rev. 1 (1 of 11)

NEI 12-02 Rev. 1		APR1400
Section	Summary	
1.0	Introduction	The guidance in this document presents an acceptable method for implementing Order EA-12-051, "Issuance of Order to Modify Licenses with regard to Reliable Spent Fuel Pool Instrumentation."
2.0	Levels Required Monitoring	
2.1	Introduction	Order EA-12-051 includes requirements as follows: All licensees identified in Attachment 1 to this Order shall have a reliable indication of the water level in associated spent fuel storage pools capable of supporting identification of the following pool water level conditions by trained personnel: (1) level that is adequate to support operation of the normal fuel pool cooling system, (2) level that is adequate to provide substantial radiation shielding for a person standing on the spent fuel pool operating deck, and (3) level where fuel remains covered and actions to implement makeup water addition should no longer be deferred.
2.2	Rational	During the events at Fukushima Dai-ichi, responders were without reliable instrumentation to determine water level in the spent fuel pool. This led to NRC concerns that the Fukushima Dai-ichi Unit 4 pool might have boiled dry, resulting in significant fuel damage. The events at Fukushima Dai-ichi demonstrated the confusion and misapplication of resources that may result from beyond-design-basis external events when reliable spent fuel pool level instrumentation is not available.
2.3	Wide Range Pool Level Instrumentation	The requirement from this order is for instrumentation that covers a wide level range within the spent fuel pool. The three critical levels that must be monitored in a spent fuel pool are described below. It should be noted that continuous indication from a single instrument over the entire span from level 1 to level 3 is not required but could be used. If more than one instrument is used to monitor the entire span,
		Conformance. Two safety-related level instruments are provided in the SFP to monitor level (1) to support operation of the normal fuel pool cooling system, (2) to provide substantial radiation shielding, and (3) to keep fuel covered and facilitate actions to implement makeup water addition.
		NA
		Conformance. Two safety-related level instruments are provided in the SFP to monitor SFP water level from level 1 to level 3 and have a capability of continuous indication. One level instrumentation channel is separated from the other instrument channel.

Table 5-10 Conformance with NEI 12-02, Rev. 1 (2 of 11)

NEI 12-02 Rev. 1		APR1400
Section	Summary	
	<p>that set of instruments constitutes a single channel satisfying either the primary or backup instrument channel requirement (refer to Figure 1).</p> <p>A visual representation of monitoring levels 1, 2 and 3 and the associated requirements for monitoring between the points are presented in Figure 1.</p> <p>The minimum requirements apply to the separation distance between level indications and support development of appropriate response procedures. These requirements are separate from the instrument channel design accuracy described in Section 3, which apply to either discrete or to continuous instruments.</p>	
2.3.1	<p>Level-1 Level that is adequate to support operation of the normal fuel pool cooling system</p> <p>Level 1 represents the HIGHER of the following two points:</p> <ul style="list-style-type: none"> • The level at which reliable suction loss occurs due to uncovering of the coolant inlet pipe, weir or vacuum breaker (depending on the design), or • The level at which the water height, assuming saturated conditions, above the centerline of the cooling pump suction provides the required net positive suction head specified by the pump manufacturer or engineering analysis. 	<p>Conformance.</p> <ul style="list-style-type: none"> • The SFP water level instruments cover Level 1. • There are siphon breaker holes above the centerline of the cooling pump suction to provide the required net positive suction head specified by the pump manufacturer or engineering analysis.
2.3.2	<p>Level-2 Level that is adequate to provide substantial radiation shielding for a person standing on the SFP operation deck</p> <p>Level 2 is based on either of the following:</p> <ul style="list-style-type: none"> • 10 ft (+/- 1 ft) above the highest point of any fuel rack seated in the spent fuel pools, or • a designated level that provides adequate radiation shielding to maintain personnel radiological dose levels within acceptable limits while performing local operations in the vicinity of the pool. <p>This level shall be based on either plant-specific or appropriate generic shielding calculations, considering the emergency conditions that may apply at the time and the scope of necessary local operations, including installation of portable SFP instrument channel components.</p> <p>Designation of this level should not be interpreted to imply that actions to initiate water makeup must be delayed until SFP water levels have reached or are lower than this point.</p>	<p>Conformance.</p> <ul style="list-style-type: none"> • The SFP water level instruments cover the Level 2. • The instruments cover 3.05 m (10 ft) above the top of spent fuel rack stored in the SFP to provide adequate radiation shielding to maintain personnel radiological dose levels within acceptable limits while performing local operations in the vicinity of the pool.

Table 5-10 Conformance with NEI 12-02, Rev. 1 (3 of 11)

NEI 12-02 Rev. 1		APR1400
Section	Summary	
2.3.3	<p>Level-3 Level where fuel remains covered and actions to implement makeup water addition should no longer be deferred</p>	<p>Level 3 corresponds nominally (i.e., +/- 1 ft) to the highest point of any fuel rack seated in the spent fuel pool. Level 3 is defined in this manner to provide the maximum range of information to operators, decision makers and emergency response personnel. Designation of this level should not be interpreted to imply that actions to initiate water makeup must or should be delayed until this level is reached.</p>
3.0	Instrumentation design features	<p>Conformance.</p> <p>The SFP water level instruments cover Level 3 to provide the maximum range of information to operators, and to provide water coverage over the spent fuel through timely makeup.</p>
3.1	Instruments	<p>Conformance.</p> <p>The spent fuel pool level instruments are permanent and fixed channel.</p> <p>The APR1400 conforms to this requirement but portable instrument is not used.</p>

Table 5-10 Conformance with NEI 12-02, Rev. 1 (4 of 11)

NEI 12-02 Rev. 1		APR1400
Section	Summary	
	<p>Portable instrument components must be stored in predetermined accessible locations that will not hinder the ability of trained personnel to install the portable components when needed.</p>	
3.2	<p>Arrangement</p> <p>Installation of the SFP instrument channels shall be consistent with the plant-specific SFP design requirements and should not impair normal SFP function.</p> <p>Channel separation should be maintained by locating the installed sensors in different places in the SFP area. Provisions for portable instruments should also consider the need for physical separation.</p> <p>Plans for portable instrument use should allow inserting and operating the sensors and associated equipment in a different part of the SFP from the permanent channel.</p> <p>Ideally the portable channel will be able to use multiple (or all) SFP locations.</p> <p>Similarly, cabling for power supplies and indications for each channel should be routed separately from cabling for the other channels.</p> <p>To the extent not otherwise covered in this guidance, the reasonable protection guidance outlined in NEI 12-06 to meet Order EA-12-049 should be used to provide protection for installed and portable channels from external hazards.</p> <p>At a minimum, cables routed outside structures should be protected in buried conduit and designed to commercial standards for submergence.</p>	<p>Conformance.</p> <p>The SFP level instrument channels are arranged to reduce the potential for falling debris or missiles affecting both channels of instrumentation and to provide reasonable protection of its function against external hazards.</p> <p>In the SFP area, cables are routed in seismically mounted rigid metal conduit. Outside the pool area, cables are routed in seismically mounted rigid metal conduit, trays, or raceways.</p>
3.3	<p>Mounting</p> <p>Consideration shall be given to the maximum seismic ground motion to the design basis of the SFP structure.</p>	<p>Conformance.</p>

Table 5-10 Conformance with NEI 12-02, Rev. 1 (5 of 11)

NEI 12-02 Rev. 1		APR1400
Section	Summary	
	<p>The mounting shall be designed consistent with the highest seismic or safety classification of the SFP.</p> <p>An evaluation of other hardware stored in the SFP shall be conducted to ensure it will not create adverse interaction with the fixed instrument location(s).</p> <p>The basis for the seismic design for mountings in the SFP shall be the plant seismic design basis at the time of submittal of the Integrated Plan for implementing NRC Order EA-12-051 (See Appendix A-2-2).</p>	Instrumentation is designed as Safety Class 3 and seismic Category I.
3.4	<p>Qualification (Guidance)</p> <p>The instrument channel reliability shall be demonstrated via an appropriate combination of design, analyses, operating experience, and/or testing of channel components for the following sets of parameters, as described in the paragraphs below:</p> <ul style="list-style-type: none"> • conditions in the area of instrument channel component use for all instrument components, • effects of shock and vibration on instrument channel components used during any applicable event for only installed components, and • seismic effects on instrument channel components used during and following a potential seismic event for only installed components. <p>Selection of instrument channel components should consider ease and simplicity of design and replacement after the event. Readily available commercial components shall be considered.</p>	See the APR1400 Actions for Qualification of Conditions for shock, vibration and seismic as described below.
	<p>Qualification (Conditions)</p> <p>The temperature, humidity and radiation levels consistent with conditions in the vicinity of the SFP and the area of use considering normal operational, event and post-event conditions for no fewer than seven days post-event or until offsite resources can be deployed by the mitigating strategies resulting from Order EA-12-049 should be considered.</p>	<p>Conformance.</p> <p>The temperature, humidity, and radiation levels consistent with conditions in the vicinity of the SFP and the area of use considering normal operational, event, and post-event conditions for no fewer than 7 days post-event are considered.</p>

Table 5-10 Conformance with NEI 12-02, Rev. 1 (6 of 11)

NEI 12-02 Rev. 1		APR1400
Section	Summary	
		The SFP instrument is designed to operate in borated and non-borated water for expected radiation levels and environments of greater than 100 °C (212 °F) and 100 % humidity.
Qualification (Shock and Vibration)	<p>For the effects of shock and vibration in the area of instrument channel component use after an event for applicable components (with the exception of battery chargers and replaceable batteries), the following measures are acceptable to verify that the design and installation is adequate.</p> <p>Applicable components of the instrument channels are rated by the manufacturer (or otherwise tested) for shock and vibration at levels commensurate with those of postulated design basis event conditions in the area of instrument channel component use using one or more of the following methods:</p> <ul style="list-style-type: none"> • instrument channel components use known operating principles, are supplied by manufacturers with commercial quality programs (such as ISO 9001) with shock and vibration requirements included in the purchase specification and/or instrument design, and commercial design and testing for operation in environments where significant shock and vibration loadings are common, such as for portable hand-held devices or transportation applications; • substantial history of operational reliability in environments with significant shock and vibration loading, such as transportation applications; or • use of components inherently resistant to shock and vibration loadings or are seismically reliable such as cables. 	<p>Conformance.</p> <p>For the effects of shock and vibration in the area of instrument channel component use after an event for applicable components (with the exception of battery chargers and replaceable batteries), either of the methods described in the NEI guidance is used.</p>
Qualification (Seismic)	For seismic effects on instrument channel components used after a potential seismic event for only installed components (with the exception of battery chargers and replaceable batteries), the following measures are acceptable to verify that the design and installation is adequate.	<p>Conformance.</p> <p>Instrumentation is designed as Safety Class 3 and seismic Category I.</p>

Table 5-10 Conformance with NEI 12-02, Rev. 1 (7 of 11)

NEI 12-02 Rev. 1		APR1400
Section	Summary	
	<p>Applicable components of the instrument channels are rated by the manufacturer (or otherwise tested) for seismic effects at levels commensurate with those of postulated design basis event conditions, in the area of instrument channel component use, using one or more of the following methods:</p> <ul style="list-style-type: none"> • instrument channel components use known operating principles, are supplied by manufacturers with commercial quality programs (such as ISO9001) with seismic requirements included in the purchase specification and/or instrument design, and commercial design and testing for operation in environments where significant seismic effects are common; • substantial history of operational reliability in environments with significant vibration, such as for portable hand-held devices or transportation applications; • demonstration of seismic reliability using methods that predict the equipment's performance by <ul style="list-style-type: none"> - analysis, - testing of the equipment under simulated seismic conditions, - using a combination of test and analysis, or - the use of experience data. • demonstration that proposed devices are substantially similar in design to models that have been previously tested for seismic effects in excess of the plant design basis at the location where the instrument is to be installed (g-levels and frequency ranges); or • seismic qualification using seismic motion consistent with that of existing design basis loading at the installation location. 	<p>Either of the methods described in the NEI 12-02 guidance and NRC staff positions for NEI12-02 specified in the JLD-ISG-2012-03 is used for demonstration of seismic adequacy.</p>
	<p>Qualification (General)</p>	<p>Conformance.</p>
3.5	<p>Independence</p>	<p>Conformance.</p>

Table 5-10 Conformance with NEI 12-02, Rev. 1 (8 of 11)

NEI 12-02 Rev. 1		APR1400
Section	Summary	
	<p>divisions / channels depending on available sources of power.</p> <p>For two (2) permanently mounted (fixed) instruments in the pool, they should be separated to the extent practicable considering existing spent fuel pool construction (reference Section 3.2).</p>	<p>Each SFP water level instrument channel has a different power source and is physically separated to the extent practicable.</p> <p>The primary instrument channel is independent of the backup instrument channel. Independence is obtained by physical separation of components between channels and the separate use of Class 1E MCC.</p>
3.6	<p>Power Supplies</p> <p>The normal electrical power supply for each channel shall be provided by different sources such that the loss of one of the channels primary power supply will not result in a loss of power supply function to both channels of SFP level instrumentation.</p> <p>All channels of SFP level instrumentation shall provide the capability of connecting the channel to a source of power (e.g., portable generators or replaceable batteries) independent of the normal plant ac and dc power systems. For fixed channels this alternate capability shall include the ability to isolate the installed channel from its normal power supply or supplies.</p> <p>The portable power sources for the portable and installed channels shall be stored at separate locations, consistent with the reasonable protection requirements associated with NEI 12-06 (Order EA-12-049).</p> <p>The portable generator or replaceable batteries should be accessible and have sufficient capacity to support reliable instrument channel operation until offsite resources can be deployed by the mitigating strategies resulting from Order EA-12-049</p> <p>If adequate power supply for either an installed or portable level instrument credits intermittent operation, then the provisions shall be made for quickly and reliably taking the channel out of service and restoring it to service.</p>	<p>Conformance.</p> <p>Each instrument channel is normally powered from a 120 Vac 60 Hz distribution panel of Class 1E 480 Vac MCC to support continuous monitoring of SFP level. On loss of normal 120 Vac power from the Class 1E 480 V MCC, each channel's internal UPS automatically transfers instrument power to a dedicated backup battery. If normal ac power is restored, the UPS automatically transfers instrument power back to the normal ac power. The dedicated backup batteries are sized to be capable of supporting continuous monitoring of SFP level for a minimum of 72 hours of operation. This provides adequate time until the onsite or offsite mobile GTG can supply power by mitigating strategies resulting from the ELAP event. Instrument accuracy and performance are not affected by restoration of power or restarting the processor.</p>

Table 5-10 Conformance with NEI 12-02, Rev. 1 (9 of 11)

NEI 12-02 Rev. 1		APR1400
Section	Summary	
3.7	<p>Accuracy</p> <p>The instrument channels shall maintain their designed accuracy following a power interruption or change in power source without recalibration.</p> <p>Accuracy should consider SFP conditions, e.g., saturated water, steam environment, or concentrated borated water.</p> <p>Additionally, instrument accuracy should be sufficient to allow trained personnel to determine when the actual level exceeds the specified lower level of each indicating range (levels 1, 2 and 3) without conflicting or ambiguous indication.</p>	<p>Conformance.</p> <p>Accuracy of the instrument channels considers SFP conditions of saturated water, steam environment, or concentrated borated water and is sufficient to allow trained personnel to determine when the actual level exceeds the specified lower level of each indicating range (Levels 1, 2, and 3) without conflicting or ambiguous indication.</p>
3.8	<p>Testing</p> <p>Static or non-active installed (fixed) sensors can be used and should be designed such that testing and /or calibration can be performed in-situ.</p> <p>For microprocessor based channels, the instrument channel design shall be capable of testing while mounted in the pool.</p> <p>Back-up portable channels shall be designed such that calibration does not require the use of any additional test or reference equipment at the time of deployment, i.e., plug-and-play type technology.</p>	<p>Conformance.</p> <p>The APR1400 use a GWR type as the SFP water level instrumentation.</p> <p>The SFP water level instrumentation is designed so that testing and/or calibration can be performed in-situ.</p> <p>The APR1400 conforms with the requirement but does not use a portable instrument.</p> <p>The COL applicant should develop the station procedures and preventive maintenance tasks to perform required surveillance testing, calibration, backup battery maintenance, functional checks, and visual inspections of the probes.</p>
3.9	<p>Display</p> <p>SFP level indication from the installed channel shall be displayed in the control room, at the alternate shutdown panel, or another appropriate and accessible location (reference NEI 12-06).</p> <p>An appropriate and accessible location shall include the following characteristics:</p>	<p>Conformance.</p> <p>The SFP water level is continuously displayed in the MCR and in the remote shutdown room (RSR).</p>

Table 5-10 Conformance with NEI 12-02, Rev. 1 (10 of 11)

NEI 12-02 Rev. 1		APR1400
Section	Summary	
	<ul style="list-style-type: none"> • occupied or promptly accessible to the appropriate plant staff giving appropriate consideration to various drain down scenarios, • outside of the area surrounding the SFP floor, e.g., an appropriate distance from the radiological sources resulting from an event impacting the SFP, • inside a structure providing protection against adverse weather, and • outside of any very high radiation areas or LOCKED HIGH RAD AREA during normal operation. <p>If multiple display locations beyond the required "appropriate and accessible location" are desired, then the instrument channel shall be designed with the capability to drive the multiple display locations without impacting the primary "appropriate and accessible" display.</p> <p>SFP level indication from a portable channel shall be displayed in an accessible location.</p>	
4.0	Program Features	
4.1	<p>Training</p> <p>The personnel performing functions associated with these SFP level instrumentation channels shall be trained to perform the job specific functions necessary for their assigned tasks (maintenance, calibration, surveillance, etc.). SFP instrumentation should be installed via the normal modification processes.</p> <p>In either case utilities should use the Systematic Approach to Training (SAT) to identify the population to be trained. The SAT process should also determine both the initial and continuing elements of the required training.</p>	<p>This section is not the scope of the standard design.</p> <p>The personnel performing functions associated with these SFP water level instrumentation channels shall be trained to perform the job-specific functions necessary for their assigned tasks (maintenance, calibration, surveillance, etc.) by the COL applicants.</p>
4.2	<p>Procedures</p> <p>If, at the time of an event or thereafter until the unit is returned to normal service, an instrument channel ceases to function, its function must be recovered within a period of time consistent with the emergency conditions that may apply at the time.</p>	<p>This section is not the scope of the standard design.</p>

Table 5-10 Conformance with NEI 12-02, Rev. 1 (11 of 11)

NEI 12-02 Rev. 1		APR1400
Section	Summary	
	<p>If, at the time of an event or thereafter until the unit is returned to normal service, an instrument channel component must be replaced, it is acceptable to use commercially available components that may or may not meet all of the qualifications (Section 3.4) to maintain the instrument channel functionality.</p> <p>All licensees shall have a strategy to ensure SFP water level addition is initiated at an appropriate time consistent with the implementation of NEI 12-06.</p>	<p>When an SFP water level instrument channel ceases to function, its function must be recovered within a period of time consistent with the emergency conditions that may apply at the time. Therefore, the COL applicants shall have a strategy for this.</p>
4.3	<p>Testing and Calibration</p> <p>Processes shall be established and maintained for scheduling and implementing necessary testing and calibration of the primary and backup SFP level instrument channels to maintain the instrument channels at the design accuracy.</p> <p>The testing and calibration of the instrumentation shall be consistent with vendor recommendations or other documented basis.</p> <p>Calibration shall be specific to the mounted instrument and the monitor.</p> <p>Surveillances or testing to validate functionality of an installed instrument channel shall be performed within 60 days of a planned refueling outage considering normal testing scheduling allowances (e.g., 25%).</p> <p>Additionally, compensatory actions must be taken if the instrumentation channel is not expected to be restored or is not restored within 90 days.</p> <p>If a single SFP for the purposes of this order is divided by the closure of a normally open gate(s) such that a portion of the SFP containing fuel used for power production within the last five years is no longer able to be monitored by a required SFP instrumentation channel, then the actions described above must be taken for the impacted instrumentation channel.</p>	<p>This section is not the scope of the standard design.</p> <p>COL applicants are responsible to establish and maintain scheduling and implementing necessary testing and calibration of the SFP level instrument channels to maintain them at the design accuracy and incorporate the specific guidance in this section of NEI 12-02, Rev. 1.</p>

TS

Figure 5-1 Timeline of the APR1400 FLEX Strategy for Full-Power Operation

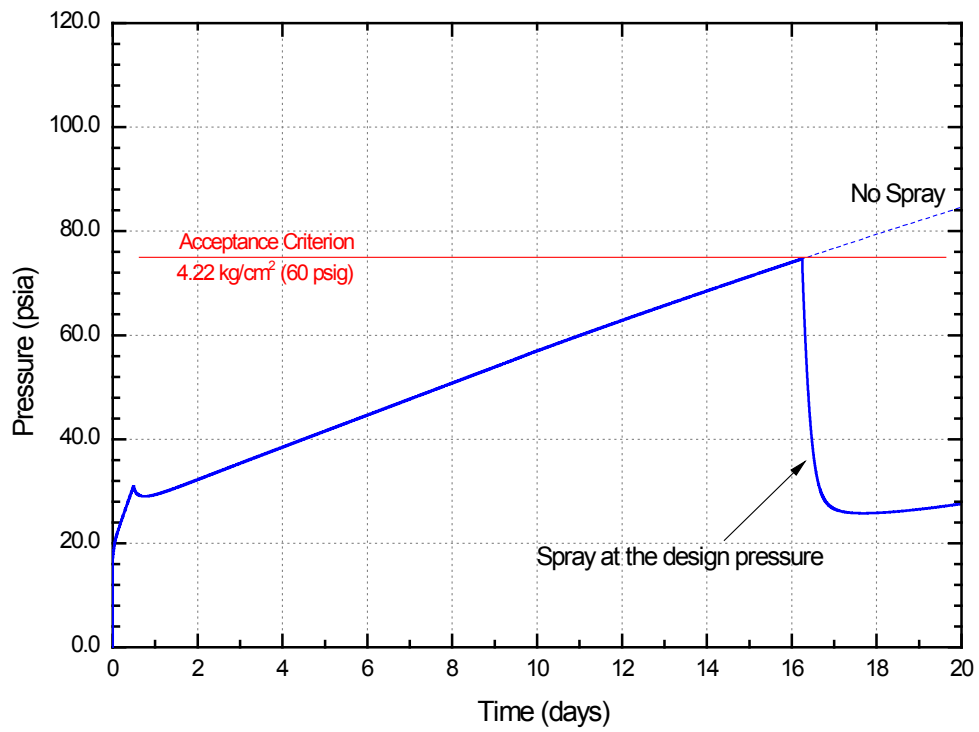

Figure 5-2 Containment Pressure for Full Power (RCP Seal LOCA)

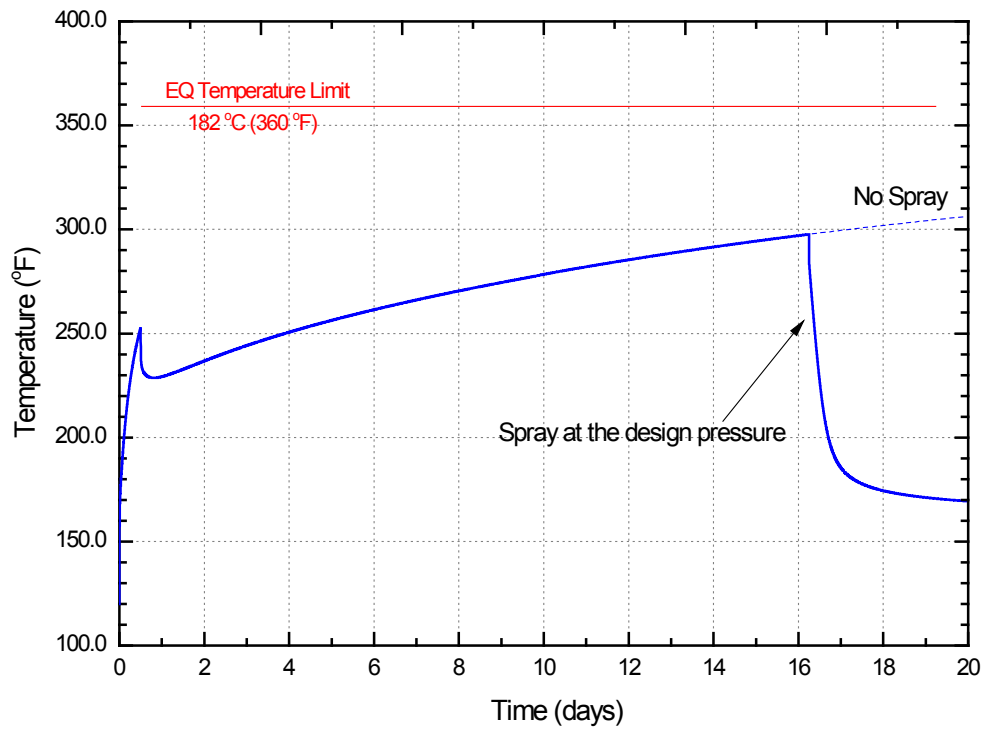

Figure 5-3 Containment Temperature for Full Power (RCP Seal LOCA)

6.0 DESIGN FEATURES AND PROGRAMS TO ADDRESS BDBEE

This chapter compiles design enhancements and programs that are incorporated into the APR1400 design to cope with the lessons learned from the accidents at TEPCO's Fukushima Dai-ichi Nuclear Power Station, and satisfy the requirements/recommendations issued after the disaster by the U.S. NRC. Design features and program descriptions, design basis, and compliance with NRC recommendations are described herein.

6.1 Overall Description

The following is the overall description:

- Fukushima issues are described in DCD Chapter 19.3.
- Compliance with NRC guidance is described in DCD Tier 2, Section 1.9.
- COL information is described in DCD Chapter 19.3.
- Connection points for FLEX equipment are incorporated in the system figures along with Table 6-1, which identifies the external connection components.
- Installed safety related pumps and valves are summarized in Table 6-2, with cross references to the DCD.
- On-Site and Off-Site FLEX equipment are summarized in Table 6-3 and Table 6-4, respectively with cross references to the DCD.

6.2 Specific Design Enhancements and Programs

6.2.1 Beyond Design Basis Seismic and Flood Protection

BDB seismic and flood protection is a COL item.

6.2.2 Primary Side FLEX Pump(s) and Connections

6.2.2.1 Design Description

One primary side FLEX pump connection has been provided into the SIS, downstream of the safety injection pump (SIP) no. 1 discharge line connection to the direct vessel injection (DVI) nozzle on the reactor vessel (RV) in the RCS, as shown in Figure 6-1. The primary side FLEX pump connection can be used by the high-head or low-head FLEX pump, depending on their necessity. The primary side high-head FLEX pump suction is the IRWST, while the low-head FLEX pump suction will be determined by the COL applicant depending on the site specific FLEX strategy for low mode operations with SGs not available. The connector size to the hose screw connector upstream of the primary FLEX pump suction is designed as 6.35 cm (2.5 in) diameter in accordance with the fire industry standard, while the primary FLEX pump suction line is designed as 10.16 cm (4 in) diameter. The connection for FLEX pump will not introduce new failure during normal plant operation by keeping the RCS pressure boundary through manual isolation (Safety Class 1) and blind flange.

6.2.2.2 Design Basis

The IRWST is used as the water source for the ACP, and the primary side high-head FLEX pump. The water volume required for RCS inventory makeup during Phase 2 of full-power operation is approximately 643.52 m³ (170,000 gal). The onsite water sources are sufficient to maintaining the plant in hot standby or hot shutdown condition for 2 weeks without considering consumption for the SFP cooling.

The primary side high-head FLEX pump is designed to supply 189.25 L/min (50 gpm) constantly, regardless of RCS pressure, in order to maintain the RCS inventory and remain in the hot shutdown condition, if the event occurs during full-power operation or lower mode of operation with SGs available. Alternatively, the low-head FLEX pump is designed to have a TDH of 160.02 m (525 ft) (17 kg/cm² A [243 psia] approximately) at 2,839 L/min (750 gpm) in order to maintain the RCS inventory and keep the cold shutdown condition by feed-and-bleed at lower modes of operation with SGs not available.

The primary side FLEX pump will be designed, manufactured, tested and installed in accordance with the applicable commercial codes and standards such as hydraulic institute pump standard, and with the design, storage, maintenance, testing as outlined in the NEI 12-06, Rev 0 Section 11.0. The primary side FLEX pump will not be designed as Seismic Category I, but will be stored in structures which are designed to satisfy GDC 2 to ensure meeting functional requirements for external environments such as seismic, flooding, wind, etc. for the specific site.

The installed non-safety related in-line valves for the safety injection system are designed as Quality Group D and Seismic Category I requirements. Since these are in-line valves, there is no specific regulating performance requirement for these components. The applicable codes and standards for valves are ASME B31.1 and B16.34

The COL applicant is responsible for determining the final FLEX pump design head considering site conditions.

6.2.2.3 Compliance with NRC Recommendation

By incorporating this design into the APR1400, an alternate strategy of providing RCS inventory makeup is available when the ACP is not available. This core cooling strategy is described as the contingency plan in Subsection 5.1.2.3 of this report. This design change increases the reliability of the IRWST to maintain RCS water inventory after a BDBEE. This design feature complies with the requirements specified in References 5, 7, and 8.

6.2.3 Spent Fuel Pool – Makeup Line and Spray Line Enhancements

6.2.3.1 Design Description

As part of the FLEX strategy to address Recommendation 4.2, Figures 6-2, 6-3, and 6-4 depict the SFP configuration to maintain SFP cooling by providing SFP makeup and SFP spray capabilities. Therefore, the following design is provided in the APR1400 to enhance the capability of the SFP diverse makeup lines and SFP spray lines to cope with BDBEEs:

- Primary Connection: Permanently installed suction connection from the RWT for FLEX pump suction.

RWT is used as the suction water source of the FLEX pumps. Two seismically qualified, 15.24 cm(6 in) diameter lines are installed downstream of RWT in the yard. The primary and secondary piping connections with isolation valves are located outside building and hose

connector are located in the yard. A 15.24 cm(6 in) flexible hose with proper fittings is connected between the water supply line and the FLEX pump suction.

- Hose connections are provided for the FLEX pump connections for the SFP spray lines and SFP diverse makeup standpipes at the exterior of the auxiliary building.

6.2.3.2 Design Basis

The SFP spray pump and SFP makeup pump will be designed, manufactured, tested and installed in accordance with the applicable commercial codes and standards such as hydraulic institute pump standard and with the design, storage, maintenance, testing as outlined in the NEI 12-06, Rev 0 Section 11.0. The SFP spray pump and SFP makeup pump will not be designed as Seismic Category I, but will be stored in structures which are designed to satisfy GDC 2 to ensure meeting functional requirements for external environments such as seismic, flooding, wind, etc. for the specific site.

The installed non-safety related in-line valves for the SFP external makeup water system are designed as Quality Group D, and Seismic Category I requirements. Since these are in-line valves, there is no specific regulating performance requirement for these components. The applicable codes and standards for valves are ASME B31.1 and B16.34.

The SFP diverse makeup and spray lines are 15.24 cm (6 in) and 10.16 cm (4 in) pipes, respectively, to accommodate the makeup flow of 1,893 L/min (500 gpm) at a discharge pressure head of 32 m (105 ft), and the spray flow of 757 L/min (200 gpm) at a discharge pressure head of 32.6 m (107 ft). Since a flow rate of 493.2 L/min (130.3 gpm), approximately, is required to restore SFP inventory during SFP boiling (see Subsection 5.1.2.4), pipe sizes for the SFP makeup and spray lines are sufficient to provide the necessary flow rate during BDBEE.

These seismically qualified SFP makeup and SFP spray lines are connected to an onsite source of water, namely, the RWT.

The COL applicant is responsible for determining the final FLEX pump design head considering site conditions.

6.2.3.3 Compliance with NRC Recommendations

By incorporating this design into the APR1400, diverse and reliable sources of makeup water to the SFP are available to cope with BDBEE. This SFP cooling strategy is described in Subsection 5.1.2.4 of this report. These design features comply with the requirements specified in References 5, 7, and 8.

6.2.4 SFP Level Instrumentation

6.2.4.1 Design Description

The key SFP water levels associated with this design are described in Subsection 5.1.3. The specific design description is as follows:

Level 1: Level adequate to support operation of the normal SFP cooling system

Indicated water level on either the primary or backup instrument channel of greater than El. 144 ft 0 in (based on ensuring the open end of the normal suction lines does not become uncovered) plus the accuracy of the SFP water level instrument channel.

Level 2: Level adequate to provide substantial radiation shielding for a person standing on the spent fuel pool operating deck

The indicated level on either the primary or backup instrument channel of greater than 3.05 m (+/-0.305 m) (10 ft [+/-1 ft]) above the top of the fuel storage racks. The 3.05 m (10 ft) criterion is conservative with regard to dose, in that the APR1400 DCD Subsections 9.1.3.1 and 9.1.3.3.4 indicate that dose would remain at or below 0.025 mSv (2.5 mrem/hr) at the surface of the water. This monitoring level provides reasonable assurance there is adequate water level to provide substantial radiation shielding for a person standing on the SFP operating deck. The elevation associated with this level is greater than 139 ft 8 in plus the accuracy of the SFP water level instrument channel, which will be determined at the COL stage.

Level 3: Level where fuel remains covered and actions to implement makeup water addition should no longer be deferred

The indicated level is on either the primary or backup instrument channel of greater than 0.305 m (1 ft) above the top of the fuel storage racks. The elevation associated with this level is greater than 129 ft 8 in plus the accuracy of the SFP water level instrument channel, which will be determined at the COL stage. This monitoring level provides assurance that there is adequate water level above the stored fuel seated in the rack.

The following instruments are provided at the SFP to address the requirements of NRC JLD-ISG-2012-03 Rev. 0 and NEI 12-02 Rev. 1. Specifically, the channels are designed as described below:

- Primary (fixed) Instrument Channel (Channel A)

The primary instrument channel provides level indication through the use of guided wave radar (GWR) technology using the principle of TDR. The instrument provides a single continuous span from above Level 1 to within 0.305 m (1 ft) of the top of the spent fuel racks.

- Backup Instrument Channel (Channel B)

The backup instrument channel is identical to the primary channel and is a permanent, fixed channel. The backup instrument channel provides level indication through the use of GWR technology using the principle of TDR. The instrument provides a single continuous span from above Level 1 to within 0.305 m (1 ft) of the top of the spent fuel racks.

The primary and backup instrument channels provide continuous level indication over a minimum range from the high SFP alarm EI. 154 ft 2 in plus the accuracy of the SFP water level instrument channel to the top of the spent fuel racks at EI 129 ft 8 in minus the accuracy of the SFP water level instrument channel.

6.2.4.2 Design Basis

The SFP instruments selected are seismically mounted. The probe is designed to operate in borated water and non-borated water over the entire expected range of pool conditions from normal water temperatures to boiling temperatures. Cables and connections are designed for expected radiation levels and environments of greater than 100 °C (212 °F) and 100 percent humidity.

6.2.4.3 Compliance with NRC Recommendations

The requirements and guidelines of NEI 12-02, Rev. 1 and NRC's JLD-ISG-2012-03, Rev. 0 are met.

6.2.5 AFWS Secondary Side FLEX Pump Connection

6.2.5.1 Design Description

Two secondary side diesel-driven FLEX pump connections are provided to the auxiliary feedwater system (AFWS) supply lines. One FLEX pump is connected to the train of the TDAFWP PP01A and the other to

the TDAFWP PP001B. The FLEX pump suction and discharge pipes are 15.24 cm (6 in) diameter with Siamese connection. The suction and discharge connections are provided at the upstream of the auxiliary feedwater pump (AFWP) suction and the upstream of the AFW modulating valve, respectively. The RWT is an alternate water source that is independent, seismically qualified, and is connected to the AFWP suction. The piping sections connected at the AFW supply lines are classified as Safety Class 3, seismic Category I. The piping section downstream of the isolation valve at the exterior of the auxiliary building up to the connector is non-safety class and designed as seismic Category I. The specific features are depicted in Figure 6-5. Also, Figure 6-6 depicts the fuel oil connection for the secondary side FLEX pumps.

6.2.5.2 Design Basis

The AFWSTs are used as the water source for the TDAFWP and the secondary side FLEX pumps. Before water in the AFWST depletes, the suction of the TDAFWP is switched to the RWT. The onsite water sources are sufficient to keep the hot shutdown condition and for continuous NCC operation for at least 11 days.

Each secondary side FLEX pump is designed to remove decay heat and keep the hot shutdown condition. The fuel for secondary side FLEX pump is supplied from the EDG fuel oil storage tank A/B as shown in Figure 6-6.

The secondary side FLEX pump will be designed, manufactured, tested and installed in accordance with the applicable commercial codes and standards such as hydraulic institute pump standard, and with the design, storage, maintenance, testing as outlined in the NEI 12-06, Rev 0 Section 11.0. The secondary side FLEX pump will not be designed as Seismic Category I, but will be stored in structures which are designed to satisfy GDC 2 to ensure meeting functional requirements for external environment such as seismic, flooding, wind, etc. for the specific site. Each secondary side FLEX pump is designed for 1,174 L/min (310 gpm) at a TDH of 160 m (525 ft).

The COL applicants are responsible to determine the final FLEX pump design head considering site conditions.

6.2.5.3 Compliance with NRC Recommendations

By incorporating this design into the APR1400, alternative water makeup sources to the TDAFWP are available to supplement the water source to the SG and provide RCS cooldown. This design increases the reliability of the AFWs to maintain the reactor core cooldown after the BDBEE. This design feature and the mitigation strategies addressed herein comply with the requirement specified in References 5, 7, and 8.

6.2.6 Electric Power Supply System

6.2.6.1 Design Description – Electrical Systems

The APR1400 has one 4.16 kVac, 5,000 kW and two 480 Vac, 1,000 kW mobile gas turbine generators for the N+1 requirement, and those mobile GTGs are designed to meet the load requirements. Subsection 5.1.2.6 provides the load list for each mobile GTG required during a BDBEE. The 480 V mobile GTG is credited to power the Class 1E 480 V load center during Phase 2, while the 4.16 kV mobile GTG is credited to power the Class 1E switchgear during Phase 3.

During Phase 2, the onsite EDG fuel oil storage tanks are used as the source of fuel for the mobile GTGs. The capacity of the each EDG fuel oil storage tank is designed to allow the mobile GTG to operate at rated power for 7 days. During Phase 3, the fuel oil source is provided by offsite sources.

The 4.16 kV mobile GTG is connected to the 4.16 kV switchgear Train A (or B), and the 480 V mobile GTG is connected to 480 V load center Train A (or B). The provisions to connect these GTGs are incorporated in the APR1400 design. The 4.16 kV GTG powers the 4.16 kV switchgear, 480 V load center and motor control center, 480 Vac / 125 Vdc battery charger, 125 Vdc battery, 125 Vdc / 120 Vac inverter, and 120 Vac distribution panel in Train A (or B). The 480 V mobile GTG powers the 480 V load center and motor control center, 480 Vac / 125 Vdc battery charger, 125 Vdc battery, 125 Vdc/120 Vac inverter, and 120 Vac distribution panel in Train A (or B).

During an ELAP, Class 1E 125 Vdc power is required for operation of 4.16 kV switchgears, 125 Vdc loads, 480 Vac MOVs and AOVs that are 125 Vdc battery backed up, I&C panels and shutdown system instrumentation, and 120 Vac loads that are inverted from 125 Vdc batteries.

Emergency Lighting and Communication

Emergency lighting in the areas such as MCR and TSC/OSC is provided from the plant Class 1E batteries during Phase 1 and mobile GTG during Phase 2. Electric power to the communication subsystem is provided from the 16 hours dedicated emergency UPS and ELAP GTG during Phases 1 and 2, respectively. Accordingly, the APR1400 design addresses the emergency lighting and communication during BDBEE.

6.2.6.2 Design Basis

The following mobile generators are used as the power source of Train A or train B power system during BDBEE:

- In Phase 2, two onsite 480V mobile GTGs are provided to meet N+1 requirement and connected to either train of the 480V load center. Each 480V mobile GTG has a capacity of 1,000 kW.
- In Phase 3, one offsite 4.16 kV mobile GTG is provided and connected to either train of the Class 1E 4.16 kV switchgear. The 4.16 kV mobile GTG has a capacity of 5,000 kW.

6.2.7 Operational Program, Procedures, and Training

The programs, procedures, guidance, and training addressing EOP/SAMGs/EDMGs for BDBEE are a COL item.

6.2.8 Emergency Procedures

The emergency communication system/enhancement, staffing large-scale natural events, and revisions to EP for ELAP are COL items.

6.2.9 Storage of FLEX Equipment

The COL applicant is responsible for addressing the details of the following guidance for the storage and deployment of the FLEX equipment:

1. The FLEX equipment is stored in dedicated buildings/structures that will provide reasonable accessibility and withstand the BDBEEs and meet the requirements of 10 CFR 50, Appendix A, GDC 2. The N+1 equipment is stored in separate buildings.
2. Suitable storage locations that provide reasonable protection during specific external events are selected in accordance with guidance provided in NEI 12-06 (Reference 8) Section 5 through 9.
3. A technical basis should be established for the storage for the FLEX equipment that provides the

inputs, assumptions, and documented basis that the mitigation strategy and support equipment will be reasonably protected from applicable external events such that the equipment could be operated in place, if applicable, or moved to its deployment locations. This basis should be auditable, consistent with generally accepted engineering principles, and controlled within the configuration document control system.

4. The FLEX equipment should be stored in storage locations chosen for the equipment that provide protection from external events as necessary to allow the equipment to perform its function without loss of capability such that no one external event can reasonably fail the site FLEX capability.
5. Storage locations must include considerations of a suitable and convenient means to bring the equipment to the connection points in time to initiate the strategy prior to expiration of the estimated capabilities to maintain core and spent fuel pool cooling, and containment functions in the initial response phase. Consideration should be given to the transport from the storage areas following the external event, recognizing that external events can result in obstacles restricting normal pathways for movement.
6. If the FLEX equipment is pre-staged such that it minimizes the time delay and burden of hook-up following an external event, then the equipment should be evaluated to not have an adverse effect on existing SSCs and the primary connection point should be as close to the intended point of supply as possible.
7. The FLEX equipment should be stored and maintained in a manner that is consistent with assuring that it does not degrade over long periods of storage and that it is accessible for periodic maintenance and testing.
8. If 50.54(hh)(2) equipment is credited in the FLEX mitigating strategies, it should meet the above storage requirements in addition to the 50.54(hh)(2) requirements.
9. Storage of debris removal equipment (if needed) should provide reasonable protection from the applicable external events such that it remains functional and deployable to clear obstructions from the pathway between the FLEX equipment's storage location and its deployment location(s).
10. Deployment of the FLEX equipment or debris removal equipment from storage locations should not depend on offsite power or onsite emergency ac power (e.g., to operate roll up doors, lifts, elevators, etc.).

6.2.10 Installed equipment and tanks utilized in the mitigation strategies

All permanent installed, safety related equipment (pumps, valves, etc.) that is utilized in the mitigation strategies for BDBEE are housed inside the reactor containment building, auxiliary building, essential service water/component cooling water heat exchanger building, emergency diesel generator building. All of these structures are safety related and are designed for seismic, flood, high wind and missile. The specific location, function, and classification of these structures are described in DCD Tier 2, Table 3.2-1.

The specific tanks (AFWST, IRWST, SIT, EDG fuel oil storage tank, EDG fuel oil day tank, BAST) are utilized in the mitigation strategies. All of these tanks are safety related, seismic Category I, and Quality Group C. DCD Tier 2, Table 3.2-1 provides the location, function, and safety classifications for these tanks. Additionally, RWT is utilized for mitigating strategies and is designed to seismic Category I and Quality Group D. It will remain functional for the mitigating strategies. The COL applicant will confirm and ensure that the RWT and flow path to the FLEX equipment (structures, piping, components, and connections) are designed to be robust with respect to applicable hazards (e.g., seismic events, floods, high winds, and missiles).

6.2.11 Connections for FLEX strategies

The detailed design of connections for FLEX strategies located outside the buildings is the responsibility of COL applicant. The COL applicant is to ensure that all the connections (See Table 6-5) for FLEX strategies located outside the buildings are accessible and protected from all applicable external hazards (e.g., seismic events, floods, high winds, and associated missiles).

Table 6-1 External Connection Components for BDBEE (1 of 2)

Component	DCD Chapter and/or Section	Function
V2601	Figure 9.1.3-1	SFP external makeup line check valve
V2602	Figure 9.1.3-1	SFP external makeup line isolation valve
V2605	Figure 9.1.3-1	SFP external spray line check valve
V2606	Figure 9.1.3-1	SFP external spray line isolation valve
V2611	Figure 9.1.3-1	SFP external makeup line check valve
V2612	Figure 9.1.3-1	SFP external makeup line isolation valve
V2615	Figure 9.1.3-1	SFP external spray line check valve
V2616	Figure 9.1.3-1	SFP external spray line isolation valve
SI-801	Table 3.9-4, Table 3.9-13, Figure 6.3.2-1 (4 of 4)	External emergency injection line check valve
SI-803	Table 3.9-4, Table 3.9-13, Figure 6.3.2-1 (4 of 4)	External emergency injection line isolation valve
SI-805	Figure 6.3.2-1 (4 of 4)	External emergency injection line fill isolation valve
SI-807	Figure 6.3.2-1 (4 of 4)	External emergency injection line isolation valve
CH-784	Figure 9.3.4-1 (4 of 7)	Primary side high-head FLEX pump suction isolation
V2678A	Figure 10.4.9-1	AF FLEX pump suction line backflow prevention
V2678B	Figure 10.4.9-1	AF FLEX pump suction line backflow prevention
V2679A	Figure 10.4.9-1	AF FLEX pump suction line isolation
V2679B	Figure 10.4.9-1	AF FLEX pump suction line isolation
V2098A	Figure 10.4.9-1	AF FLEX pump discharge line backflow prevention
V2098B	Figure 10.4.9-1	AF FLEX pump discharge line backflow prevention
V2102A	Figure 10.4.9-1	AF FLEX pump discharge line isolation
V2102B	Figure 10.4.9-1	AF FLEX pump discharge line isolation
V2001A	Figure 9.5.4-1	Diesel fuel oil day tank discharge line to mobile equipment header isolation
V2001B	Figure 9.5.4-1	Diesel fuel oil day tank discharge line to mobile equipment header isolation
V2202A	Figure 9.5.4-1	Diesel fuel oil supply line to mobile GTG isolation
V2202B	Figure 9.5.4-1	Diesel fuel oil supply line to mobile GTG isolation
V2203A	Figure 9.5.4-1	Diesel fuel oil supply line to AF FLEX pump isolation
V2203B	Figure 9.5.4-1	Diesel fuel oil supply line to AF FLEX pump isolation
V2204A	Figure 9.5.4-1	Diesel fuel oil supply line to primary high-head pump isolation
V2204B	Figure 9.5.4-1	Diesel fuel oil supply line to primary high-head pump isolation

Table 6-1 External Connection Components for BDBEE (2 of 2)

Component	DCD Chapter and/or Section	Function
V2205A	Figure 9.5.4-1	Diesel fuel oil supply line to primary low-head pump isolation
V2205B	Figure 9.5.4-1	Diesel fuel oil supply line to primary low-head pump isolation
V2206A	Figure 9.5.4-1	Diesel fuel oil supply line to SFP pump isolation
V2206B	Figure 9.5.4-1	Diesel fuel oil supply line to SFP pump isolation
V2207A	Figure 9.5.4-1	Diesel fuel oil supply line to SFP spray pump isolation
V2207B	Figure 9.5.4-1	Diesel fuel oil supply line to SFP spray pump isolation
V2208A	Figure 9.5.4-1	Diesel fuel oil supply line to ECSBS FLEX pump
V2208B	Figure 9.5.4-1	Diesel fuel oil supply line to ECSBS FLEX pump
Circuit Breaker of Class 1E 4.16 kV Switchgear 01A (1-823-E-SW01A)	Figure 8.1-1 (1 of 2)	Provision for connecting to 4.16 kV mobile generator
Circuit Breaker of Class 1E 4.16 kV Switchgear 01B (1-823-E-SW01B)	Figure 8.1-1 (2 of 2)	Provision for connecting to 4.16 kV mobile generator
Circuit Breaker of Class 1E 480 V Load Center 01A (1-825-E-LC01A)	Figure 8.1-1 (1 of 2)	Provision for connecting to 480V mobile generator
Circuit Breaker of Class 1E 480 V Load Center 01B (1-825-E-LC01B)	Figure 8.1-1 (2 of 2)	Provision for connecting to 480V mobile generator
Battery	9.5.2.1	The communication systems are powered from one of the two dedicated 16-hour-rated non-safety-related batteries (normal and standby) in case of either AAC GTG failure during a LOOP or SBO condition.

Table 6-2 List of Installed Safety Related Pumps and Valves for BDBEE (1 of 2)

Description	DCD Tier 2 Reference
Turbine driven Auxiliary Feedwater Pump	10.4.9, Table 10.4.9-1
Main Steam Safety Valve	10.3.2, Table 10.3.2-1
Main Steam Atmospheric Dump Valve	10.3.2, Table 10.3.2-1
Auxiliary Charging Pump	9.3.4, Table 9.3.4-2
Boric Acid Makeup Pump	9.3.4, Table 9.3.4-2
Boric Acid Makeup Pump	9.3.4, Table 9.3.4-2
Direct Boration Valve	9.3.4, *
BAST Gravity Valve (Train A)	9.3.4, *
BAST Gravity Valve (Train B)	9.3.4, *
Charging Containment Isolation Valve	9.3.4, Table 6.2.4-1
Diesel Fuel Oil Transfer Pump 1-595-PP01A	9.5.4, Table 9.5.4-1
Diesel Fuel Oil Transfer Pump 1-595-PP02A	9.5.4, Table 9.5.4-1
Diesel Fuel Oil Transfer Pump 1-595-PP01B	9.5.4, Table 9.5.4-1
Diesel Fuel Oil Transfer Pump 1-595-PP02B	9.5.4, Table 9.5.4-1
Shutdown Cooling Pump-1	5.4.7, Table 5.4.7-1
Shutdown Cooling Pump-2	5.4.7, Table 5.4.7-1
SCS Suction Line Isolation Valve SI-651	5.4.7, *
SCS Suction Line Isolation Valve SI-652	5.4.7, *
SCS Suction Line CTMT Isolation Valve SI-655	5.4.7, Table 6.2.4-1
SCS Suction Line Isolation Valve SI-656	5.4.7, *
SCS Warmup Line Isolation Valve SI-690	5.4.7, *
SCS Warmup Line Isolation Valve SI-691	5.4.7, *
SCS Test Return Line Isolation Valve SI-314	5.4.7, *
SCS Test Return Line Isolation Valve SI-315	5.4.7, *
SCS Test Return Line Isolation Valve SI-688	5.4.7, *
SCS Test Return Line Isolation Valve SI-693	5.4.7, *
SDCHX Bypass Flow Control Valve SI-312	5.4.7, *
SDCHX Bypass Flow Control Valve SI-313	5.4.7, *
SDCHX Discharge Isolation and Throttle Valve SI-310	5.4.7, *
SDCHX Discharge Isolation and Throttle Valve SI-311	5.4.7, *
IRWST Return Line CTMT Isolation Valve SI-300	5.4.7, Table 6.2.4-1
IRWST Return Line CTMT Isolation Valve SI-301	5.4.7, Table 6.2.4-1
SCS DVI CTMT Isolation Valve SI-600	5.4.7, Table 6.2.4-1
SCS DVI CTMT Isolation Valve SI-601	5.4.7, Table 6.2.4-1
IRWST Return Line Isolation Valve SI-395	5.4.7, *
SIP/SCP Suction Cross Connection Valve SI-344	5.4.7, *
SIP/SCP Suction Cross Connection Valve SI-346	5.4.7, *
CCW Pump 1A	9.2.2, Table 9.2.2-4
CCW Pump 1B	9.2.2, Table 9.2.2-4
CCW HX HE01A Outlet Valve 1-461-V-0021	9.2.2, Table 9.2.2-5
CCW HX HE01B Outlet Valve 1-461-V-0022	9.2.2, Table 9.2.2-5
CCW HX HE02A Outlet Valve 1-461-V-0023	9.2.2, Table 9.2.2-5

Table 6-2 List of Installed Safety Related Pumps and Valves for BDBEE (2 of 2)

Description	DCD Tier 2 Reference
CCW HX HE02B Outlet Valve 1-461-V-0024	9.2.2, Table 9.2.2-5
CCW HX HE03A Outlet Valve 1-461-V-0025	9.2.2, Table 9.2.2-5
CCW HX HE03B Outlet Valve 1-461-V-0026	9.2.2, Table 9.2.2-5
CCW HX Bypass ISOL Valve 1-461-V-0027	9.2.2, Table 9.2.2-5
CCW HX Bypass ISOL Valve 1-461-V-0028	9.2.2, Table 9.2.2-5
Non-Safety Load ISOL Valve 1-461-V-0143	9.2.2, Table 9.2.2-5
Non-Safety Load ISOL Valve 1-461-V-0144	9.2.2, Table 9.2.2-5
Non-Safety Load ISOL Valve 1-461-V-0149	9.2.2, Table 9.2.2-5
Non-Safety Load ISOL Valve 1-461-V-0150	9.2.2, Table 9.2.2-5
DG A HX Inlet ISOL Valve 1-461-V-0191	9.2.2, Table 9.2.2-5
DG B HX Inlet ISOL Valve 1-461-V-0192	9.2.2, Table 9.2.2-5
RCP Cooling Return CTMT ISOL Valve 1-461-V-0249	9.2.2, Table 6.2.4-1
Letdown HX Cooling Supply CTMT ISOL Valve 1-461-V-0296	9.2.2, Table 6.2.4-1
Letdown HX Cooling Supply CTMT ISOL Valve 1-461-V-0297	9.2.2, Table 6.2.4-1
Letdown HX Cooling Return CTMT ISOL Valve 1-461-V-0301	9.2.2, Table 6.2.4-1
Letdown HX Cooling Return CTMT ISOL Valve 1-461-V-0302	9.2.2, Table 6.2.4-1
SC HX 01A Inlet ISOL Valve 1-461-V-0351	9.2.2, *
SC HX 01B Inlet ISOL Valve 1-461-V-0352	9.2.2, *
ESSEN CHLR CNDSR 1A Outlet ISOL Valve 1-461-V-0383	9.2.2, *
ESSEN CHLR CNDSR 1B Outlet ISOL Valve 1-461-V-0384	9.2.2, *
SFP Cooling HX 02A Inlet ISOL Valve 1-461-V-0389	9.2.2, *
SFP Cooling HX 02B Inlet ISOL Valve 1-461-V-0390	9.2.2, *
Essential Service Water (ESW) Pump 1A	9.2.1, Table 9.2.1-1
Essential Service Water (ESW) Pump 1B	9.2.1, Table 9.2.1-1
ESW PP 01A DISCH Valve 1-462-V-0045	9.2.1, *
ESW PP 01B DISCH Valve 1-462-V-0046	9.2.1, *
ESW Flow Control Valve 1-462-V-0071	9.2.1, *
ESW Flow Control Valve 1-462-V-0072	9.2.1, *
Cooling Tower Bypass Valve 1-462-V-0075	9.2.1, *
Cooling Tower Bypass Valve 1-462-V-0076	9.2.1, *
MSADV Inlet Isolation Valve 1-521-V105	10.3.2, *
MSADV Inlet Isolation Valve 1-521-V106	10.3.2, *
MSADV Inlet Isolation Valve 1-521-V107	10.3.2, *
MSADV Inlet Isolation Valve 1-521-V108	10.3.2, *
Aux. Feedwater CTMT Isolation Valve 1-542-V-0043	10.4.9, Table 6.2.4-1
Aux. Feedwater CTMT Isolation Valve 1-542-V-0044	10.4.9, Table 6.2.4-1
Essential Chilled Water Pump 1A	9.2.7, Table 9.2.7-1
Essential Chilled Water Pump 1A	9.2.7, Table 9.2.7-1

* These valves are inline valves, and there is no unique performance requirement for these valves.

Table 6-3 List of On-site FLEX Equipment for BDBEE (1 of 2)

Item No	Description	Quantity	Interface Design parameters ^(Note)	Functional Requirements	Reference
1	Primary side high-head FLEX pump	Two (2)	<ul style="list-style-type: none"> • Diesel driven • Flowrate: 189.25 L/min (50 gpm) • Operating Pressure: 105.46 kg/cm²A (1,500 psia) • Water Source: IRWST 	Supply makeup water to RCS when ACP is not available.	DCD Tier 2 Subsection 19.3.2.3.1.1 TeR Sections 5.1.2.3.1.2.2 & 6.2.2.2
2	Primary side low-head FLEX pump	Two (2)	<ul style="list-style-type: none"> • Diesel driven • Flowrate: 2,839 L/min(750 gpm) • TDH: 160 m (525 ft) • Water Source: Available borated water source (COL 19.3(17)) 	Supply makeup water to RCS during Phase 2 when SGs are not available.	DCD Tier 2 Subsection 19.3.2.3.1.3 TeR Sections 5.1.2.3.3.2 & 6.2.2.2
3	Secondary side FLEX pump	Three (3)	<ul style="list-style-type: none"> • Diesel driven • Flowrate: 1,174 L/min (310 gpm) • TDH: 160 m (525 ft) • Water Source: AFWST and RWT 	Supply cooling water to SGs when TDAFWP is not available.	DCD Tier 2 Subsection 19.3.2.3.1.1 TeR Sections 5.1.2.3.1.2.2 & 6.2.5.2
4	SFP Makeup FLEX pump	One (1)	<ul style="list-style-type: none"> • Diesel driven • Flowrate: 1,893 L/min (500 gpm) • Discharge Pressure: 32 m (105 ft) • Water Source: RWT 	Supply makeup water to SFP.	DCD Tier 2 Subsection 19.3.2.3.2 TeR Sections 5.1.2.4.1.2 & 6.2.3.2
5	SFP Spray FLEX pump	One (1)	<ul style="list-style-type: none"> • Diesel driven • Flowrate: 757 L/min (200 gpm) • Discharge Pressure: 32.6 m (107 ft) • Water Source: RWT 	Supply makeup water to SFP.	DCD Tier 2 Subsection 19.3.2.3.2 TeR Sections 5.1.2.4.1.2 & 6.2.3.2
6	ECSBS FLEX Pump	One (1)	<ul style="list-style-type: none"> • Diesel driven • Flowrate: 2,839 L/min (750 gpm) • Discharge Pressure: 200 m (656 ft) • Water Source: RWT 	Supply water to containment atmosphere to prevent containment overpressurization during low mode operation.	DCD Tier 2 Subsection 19.3.2.3.3 TeR Sections 5.1.2.5

Table 6-3 List of On-site FLEX Equipment for BDBEE (2 of 2)

Item No	Description	Quantity	Interface Design parameters ^(Note)	Functional Requirements	Reference
7	480 V mobile GTG	Two (2)	1000 kW each	Supply power to 480 V load center, motor control center, and 125 Vdc battery charger via 480 V Class 1E power system Train A or B during Phase 2.	DCD Tier 2 Subsection 19.3.2.3.1.1 TeR Sections 5.1.2.6.1.1, 6.2.6, and Table 5-5

(Note) The COL applicant is responsible for determining the final FLEX pump design head considering site conditions.

Table 6-4 List of Off-site FLEX Equipment for BDBEE

Item No	Description	Quantity	Interface Design parameters	Functional Requirements	Reference
1	4.16 kV mobile GTG	One (1)	5000 kW	Supply power to 4.16 kV switchgear and etc., and restore Train A or B of the Class 1E power system during Phase 3.	DCD Tier 2 Subsection 19.3.2.3.1.1 TeR Sections 5.1.2.6.1.1, 6.2.6, and Table 5-5

Table 6-5 List of Connection for FLEX strategies

Flex Equipment	Connections	Quantity	Location	Functional Requirement
Primary side high-head or primary side low-head FLEX pump	Discharge connection	1	Outside Building	To supply makeup water to RCS
SFP makeup FLEX pump	Discharge connections	2	Outside Building	To supply makeup water to SFP
SFP spray FLEX pump	Discharge connections	2	Outside Building	To supply makeup water to SFP
ECSBS FLEX pump	Discharge connection	1	Outside Building	To prevent containment over-pressurization
Secondary side FLEX pump	Discharge connections	2	Outside Building	To supply cooling water to associated SG
Secondary side FLEX pump	Suction connections	2	Outside Building	To supply cooling water to associated SG
Primary side high-head FLEX pump	Suction connection	1	Outside Building	To supply makeup water to RCS
FLEX pumps and mobile GTGs	Fuel oil supplying connections	14	Outside Building	To supply fuel oil to FLEX pumps and mobile GTG
The 480 V mobile GTG	Electrical connections	2	COL 19.3(10)	To supply the power to Class 1E 480 V load centers
The 4.16 kV mobile GTG	Electrical connections	2	COL 19.3(10)	To supply the power to 4.16 kV switchgear

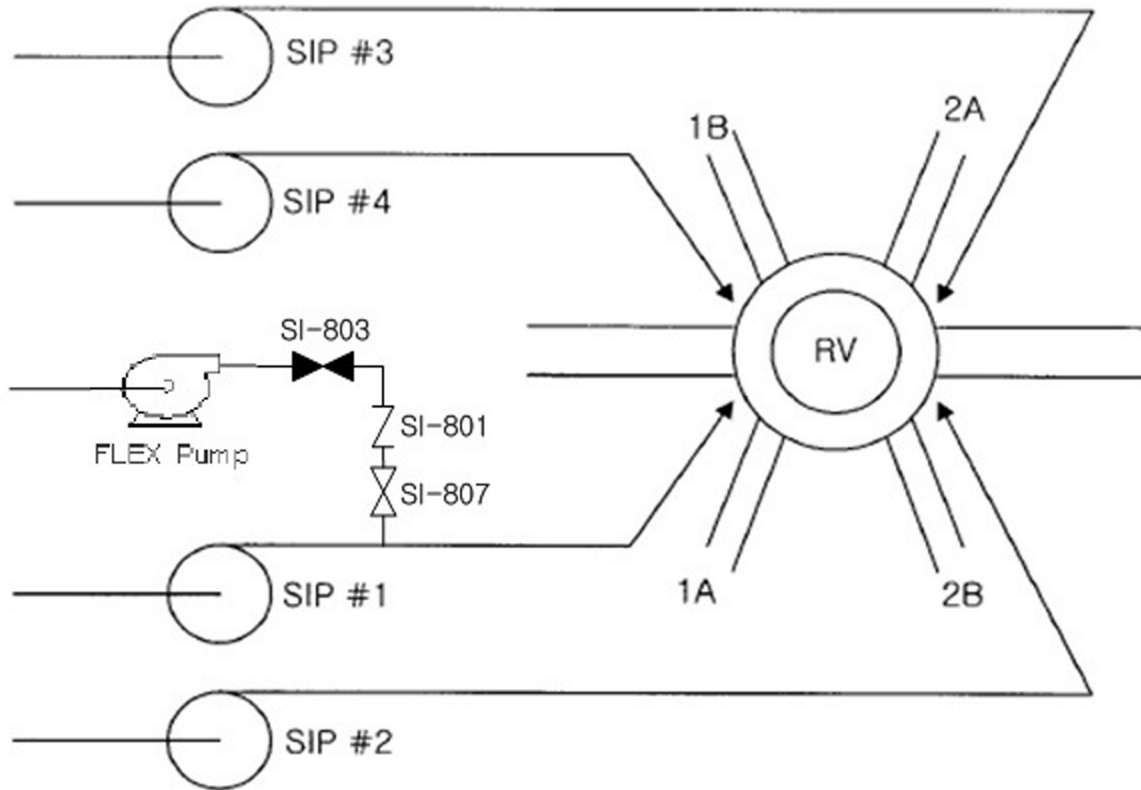

Figure 6-1 Primary Side FLEX Pump Connection into the Safety Injection System

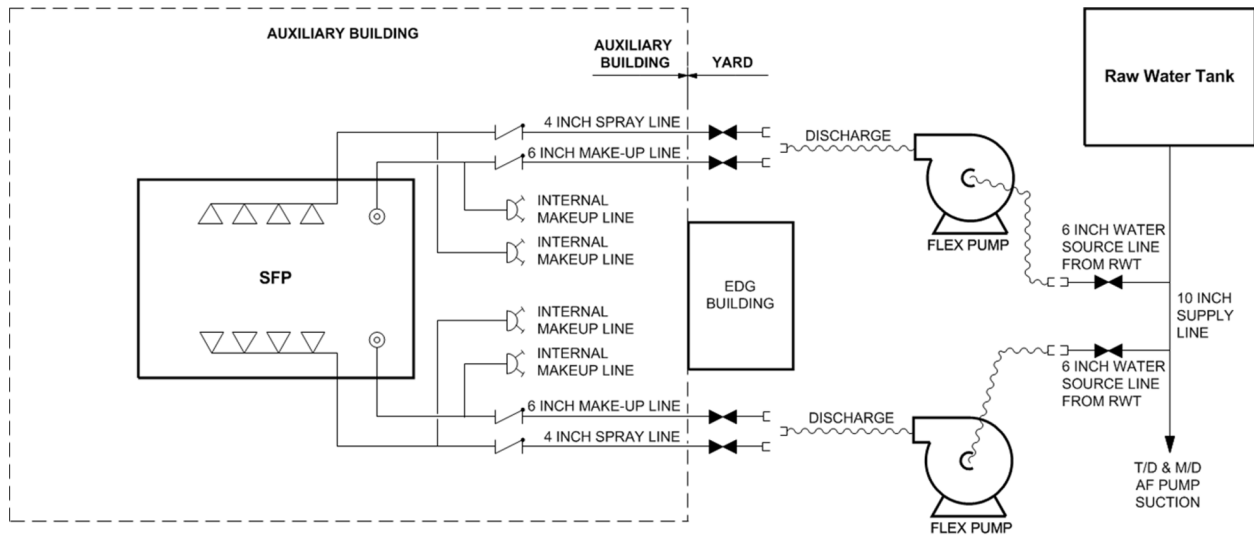

Figure 6-2 FLEX Pump Suction Source for SFP Makeup and Spray Line

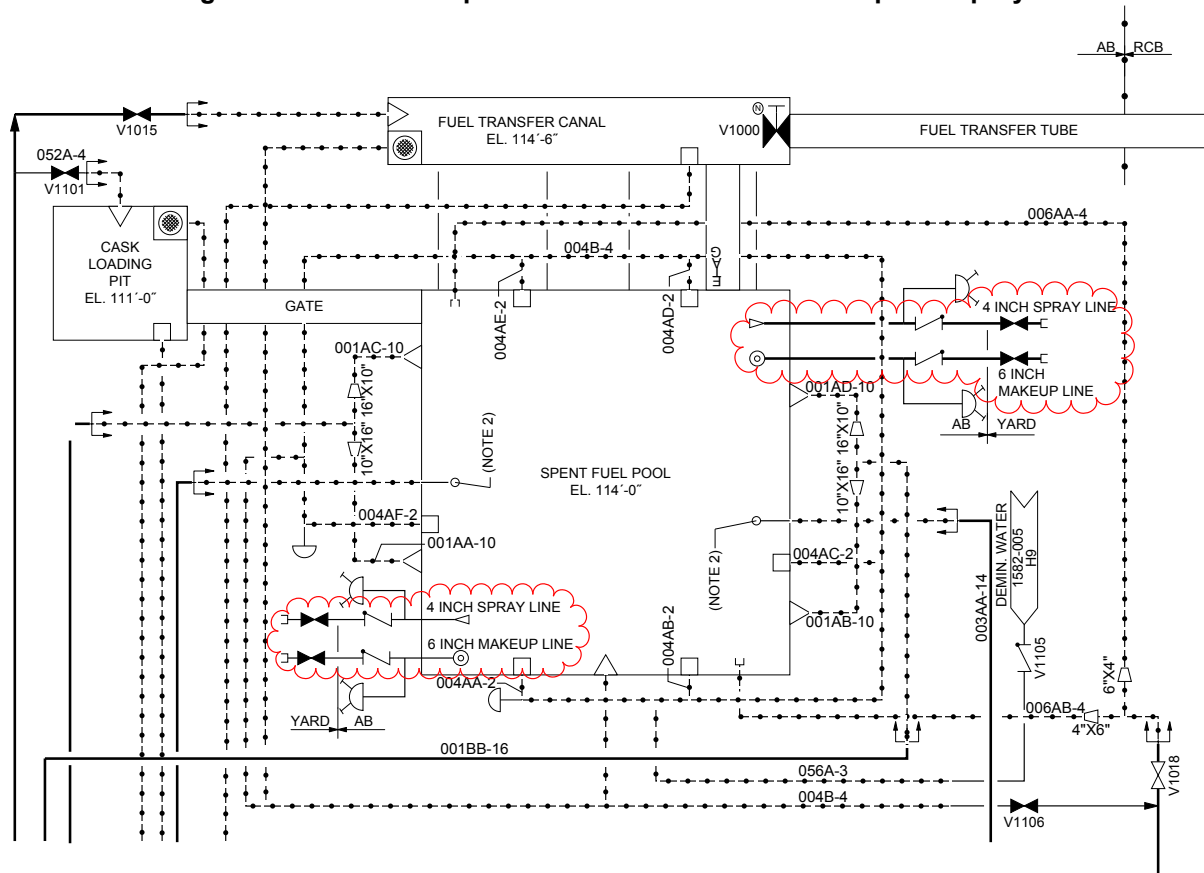

Figure 6-3 Connection for SFP Makeup and Spray Line

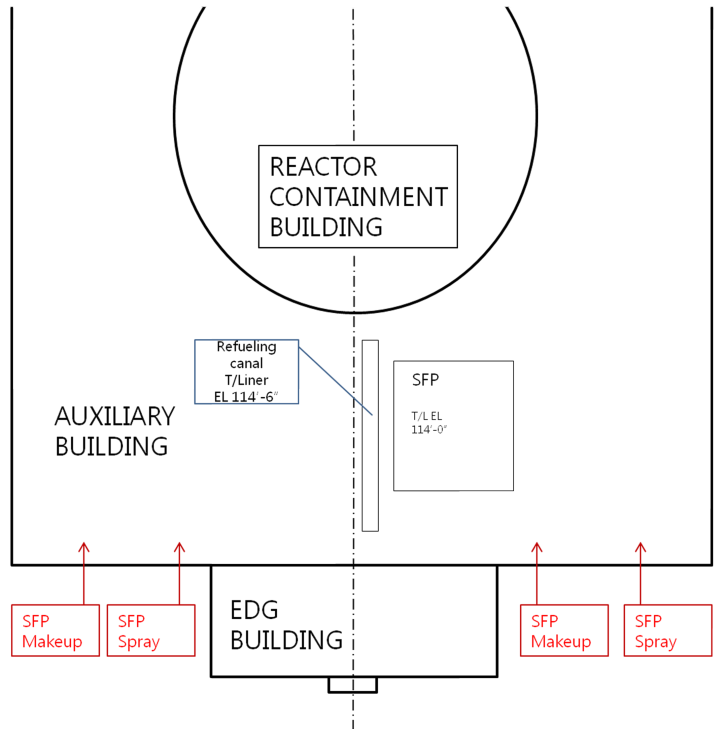

Figure 6-4 Layout of SFP Makeup and SFP Spray Line Connections

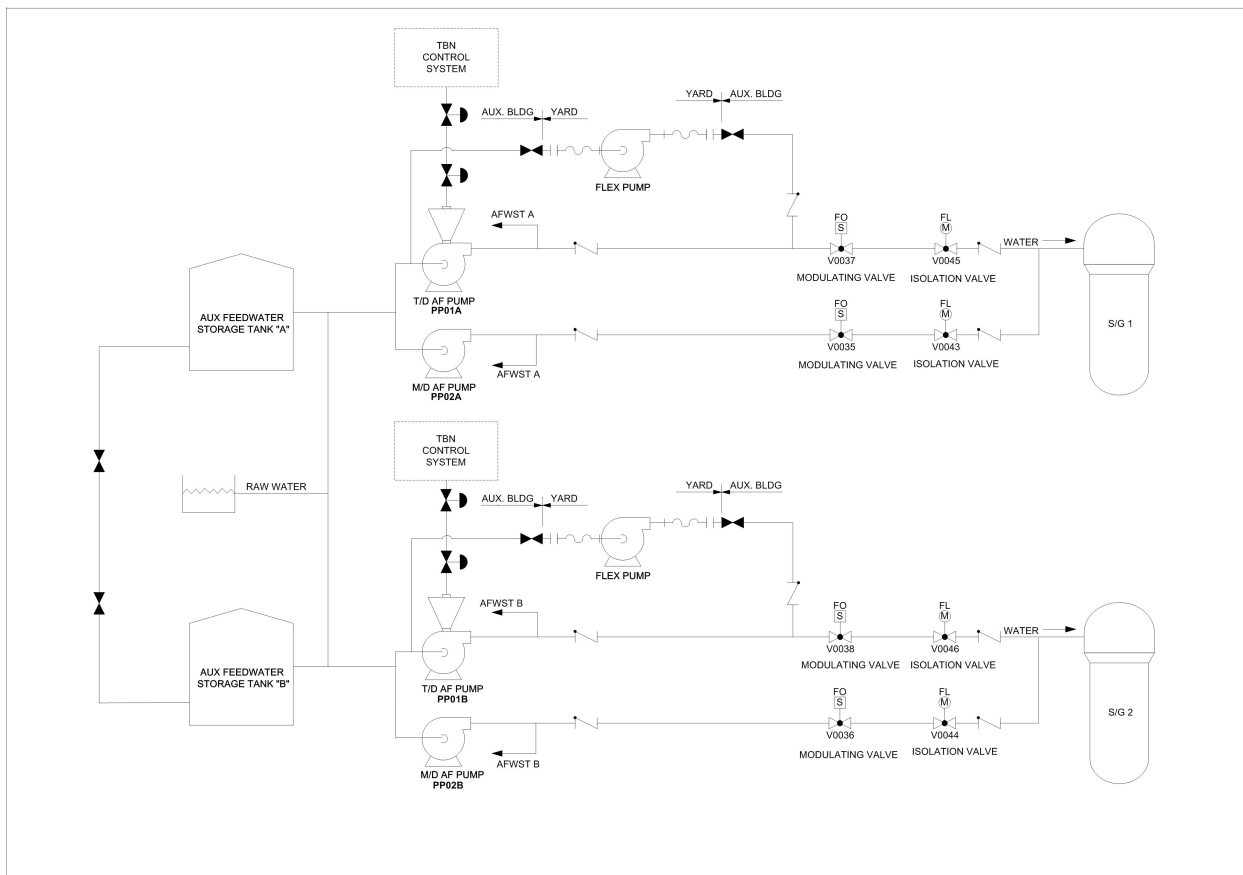

Figure 6-5 Water Supply System to the Secondary Side of SG

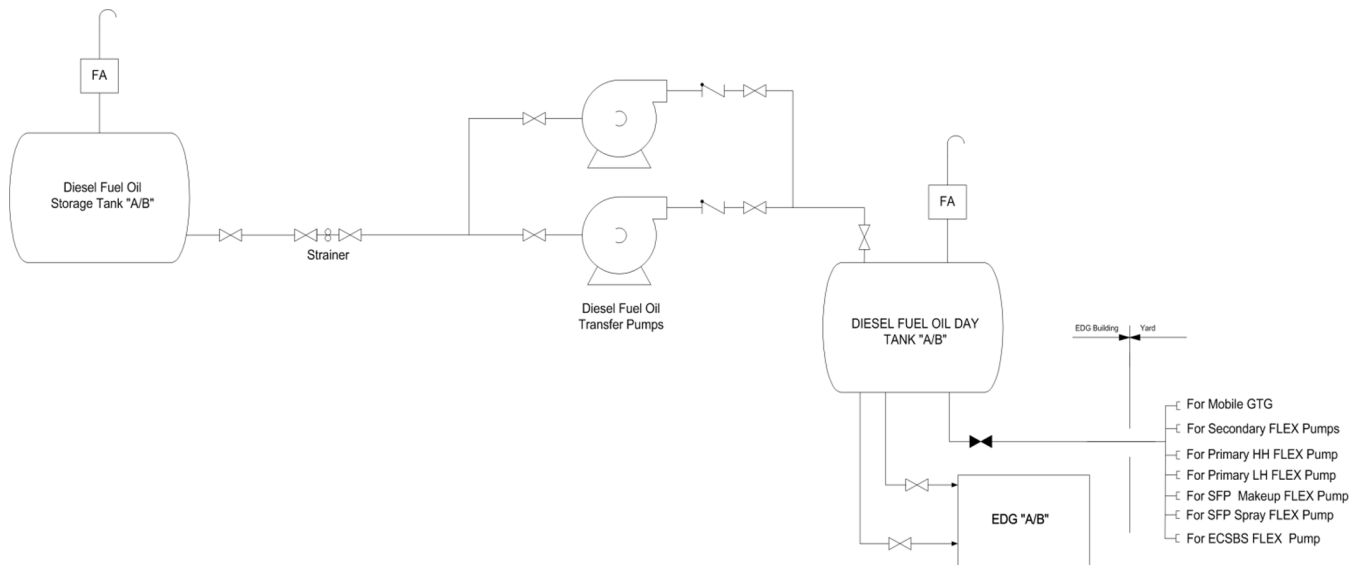

Figure 6-6 Fuel Oil Supply System to FLEX Pumps

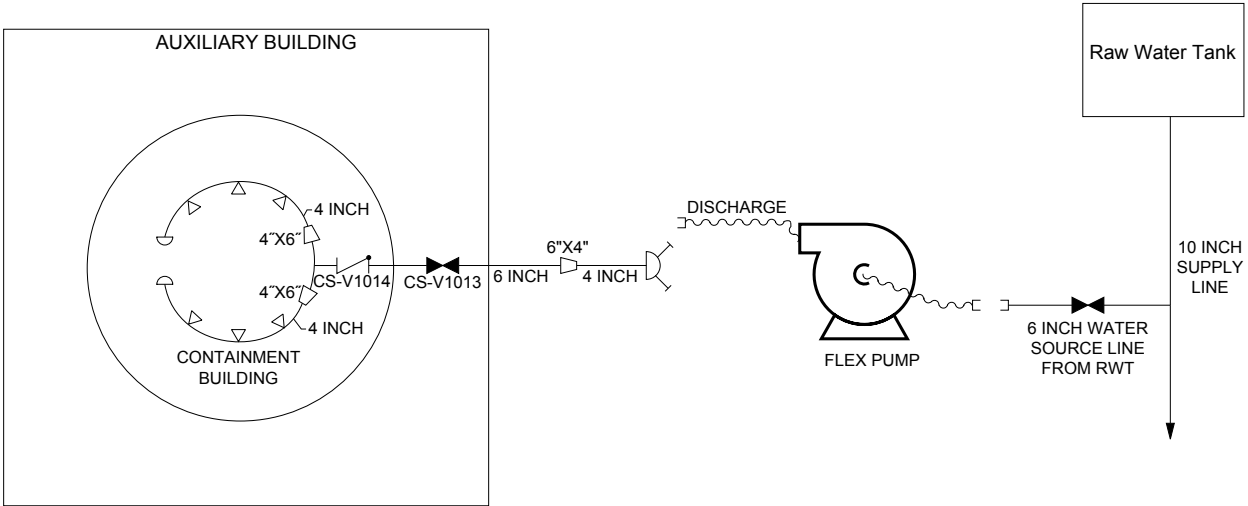

Figure 6-7 Flow Path for FLEX Connection to Deliver Water to Containment for ECSBS

7.0 CONCLUSION

The APR1400 strategy and design enhancement along with regulatory recommendations and regulatory requirements related to lessons learned from the accident at Fukushima Dai-ichi Nuclear Power Plant after the 2011 Great Tohoku Earthquake on March 11, 2011 are described in this Technical Report. The impact assessments to the current APR1400 DCD are prepared. Multiple design enhancements are identified and have been implemented with the objective to enhance mitigation capability to beyond-design-basis external events. The design enhancements described in this report increase the APR1400 reliability for safety against the BDBEE. The operational and programmatic aspects of responding to the BDBEE CCW will be addressed by COL applicants prior to the initial fuel loading.

8.0 REFERENCES

1. SECY-11-0093, "Recommendations for Enhancing Reactor Safety in the 21st Century," U.S. Nuclear Regulatory Commission, July 2011.
2. SECY-11-0137, "Prioritization of Recommended Actions to be Taken in Response to Fukushima Lessons Learned," U.S. Nuclear Regulatory Commission, October 2011.
3. SECY-12-0025, "Proposed Orders and Requests for Information in Response to Lessons Learned from Japan's March 11, 2011, Great Tohoku Earthquake and Tsunami," U.S. Nuclear Regulatory Commission, February 2012.
4. SECY-12-0095, "Tier 3 Program Plans and 6-Month Status Update in Response to Lessons Learned from Japan's March 11, 2011, Great Tohoku Earthquake and Subsequent Tsunami," U.S. Nuclear Regulatory Commission, July 2012.
5. Order EA-12-049, "Order Modifying Licenses with Regard to Requirements for Mitigation Strategies for Beyond-Design-Basis External Events," U.S. Nuclear Regulatory Commission, March 12, 2012.
6. Order EA-12-051, "Order Modifying Licenses with Regard to Reliable Spent Fuel Pool Instrumentation," U.S. Nuclear Regulatory Commission, March 2012.
7. JLD-ISG-2012-01 "Compliance with Order EA-12-049, Order Modifying Licenses with Regard to Requirements for Mitigation Strategies for Beyond-Design-Basis External Events," Rev. 0, U.S. Nuclear Regulatory Commission, August 29, 2012.
8. NEI 12-06, "Diverse and Flexible Coping Strategies (FLEX) Implementation Guide," Rev. 0, Nuclear Energy Institute, August 2012.
9. APR1400-A-M-NR-14002-P, "Extended Loss of AC Power Capability for APR1400 KSB RCP Seals," Rev.1, KHNP, January 2017.
10. NEI White Paper, "Battery Life Issue," Nuclear Energy Institute, August 2013.
11. NRC Letter dated September 2013 to NEI endorsing Reference 10 with clarifications.
12. NEI 12-02, "Industry Guidance for Compliance with NRC Order EA-12-051, 'To Modify Licenses with Regard to Reliable Spent Fuel Pool Instrumentation,'" Rev. 1, Nuclear Energy Institute, August 2012.
13. JLD-ISG-2012-03, "Compliance with Order EA-12-051, Reliable Spent Fuel Pool Instrumentation," Rev. 0, U.S. Nuclear Regulatory Commission, August 2012.
14. IEEE Std 344-2004, "IEEE Recommended Practice for Seismic Qualification of Class 1E Equipment for Nuclear Power Generating Stations," Institute of Electrical and Electronics Engineers, June 2005.
15. Enclosure 5 to "Request for Information Pursuant to Title 10 of the Code of Federal Regulations 50.54(f) Regarding Recommendations 2.1, 2.3, and 9.3 of the Near-Term Task Force Review of Insights from the Fukushima Dai-Ichi Accident," March 2012.
16. NEI 12-01, "Guideline for Assessing Beyond Design Basis Accident Response Staffing and Communication Capabilities," Rev. 0, Nuclear Energy Institute, May 2012.

APPENDIX. A

Supporting Analysis Results for the Operational Strategy for Core Cooling

TABLE OF CONTENTS

A.1	INTRODUCTION.....	A1
A.2	COMPUTER CODE	A1
A.3	ACCEPTANCE CRITERIA	A1
A.4	ANALYSIS CONDITION AND ASSUMPTION.....	A1
A.4.1	Power Operation and Shutdown Operations with SGs Available	A1
A.4.2	Shutdown Operations with SGs not Available	A2
A.5	ANALYSIS RESULTS	A2
A.5.1	Full-Power Operation.....	A2
A.5.1.1	Core Cooling – Full-Power Operation Basic Strategy of RCS Cooldown (Using Installed Pumps).....	A2
A.5.1.2	Core Cooling – Full-Power Operation Contingency Plan (Using FLEX Pumps)	A3
A.5.1.3	Subcriticality – Full-Power Operation FLEX Strategy.....	A4
A.5.2	Lower-Power Operation and Shutdown Conditions with SGs Available	A4
A.5.2.1	Coping Capability – Mode 1 through Mode 3	A4
A.5.2.2	Coping Capability – Mode 4 and Mode 5 with SGs Available	A5
A.5.3	Shutdown Condition with SGs not Available.....	A5

LIST OF TABLES

Table A-1 Sequence of Events for Coping Operation Against ELAP/LUHS Occurred at Full-Power OperationA6

LIST OF FIGURES

Figure A-1 RCS and Steam Generator Pressure (Basic Strategy) 7

Figure A-2 RCS Temperature (Basic Strategy) 7

Figure A-3 SIT Flow (Basic Strategy) 8

Figure A-4 ACP Flow (Basic Strategy) 8

Figure A-5 RCS Leak Flow (Basic Strategy) 9

Figure A-6 RCS Pressurizer Water Level (Basic Strategy) 9

Figure A-7 Collapsed Downcomer and Core Level (Basic Strategy) 10

Figure A-8 Cladding Temperature (Basic Strategy)..... 10

Figure A-9 MSADV, MSSV Flow (Basic Strategy)..... 11

Figure A-10 Integration of AFW Flow (Basic Strategy)..... 11

Figure A-11 RCS and Steam Generator Pressure (Contingency Plan)..... 12

Figure A-12 RCS Temperature (Contingency Plan) 12

Figure A-13 SIT Flow (Contingency Plan) 13

Figure A-14 Primary FLEX Pump Flow (Contingency Plan)..... 13

Figure A-15 RCS Leak Flow (Contingency Plan) 14

Figure A-16 Pressurizer Water Level (Contingency Plan)..... 14

Figure A-17 Collapsed Downcomer and Core level (Contingency Plan) 15

Figure A-18 Cladding Temperature (Contingency Plan)..... 15

Figure A-19 MSADV, MSSV Flow (Contingency Plan)..... 16

Figure A-20 Integration of AFW Flow (Contingency Plan)..... 16

Figure A-21 Reactivity Changes during RCS Cooldown (with RCP Leak)..... 17

Figure A-22 Reactivity Changes during RCS Cooldown (No RCP Leak)..... 17

Figure A-23 RCS Pressure 18

Figure A-24 RCS Temperature 18

Figure A-25 LTOP Valve Flow..... 19

APPENDIX.A Supporting Analysis Results for the Operational Strategy for Core Cooling

A.1 Introduction

This appendix provides the supporting analyses and their results for the APR1400 core cooling capability to cope with the BDBEE, ELAP concurrent with LUHS. Specifically, the coping capability is evaluated according to the FLEX strategies described in the Subsection 5.1.2.3, for the following operation modes:

- Full-power operation
- Low-power operations and shutdown conditions with SGs available

A.2 Computer Code

A best-estimate computer code, named RELAP5/Mod 3.3, is used for the supporting analyses for the APR1400 operational strategy for core cooling. The RELAP5 code was approved by the NRC and has been widely used for the safety analysis of nuclear power plants of all over the world. The RELAP5 code is based on a non-equilibrium separated two-phase flow model and has other additional models to properly describe the thermal-hydraulic behavior of components of reactor systems including heat conduction in the core and reactor coolant system, reactor kinetics, control systems and trips.

A.3 Acceptance Criteria

The following acceptance criteria based on NEI 12-06, Section 3.2.1 are applied to the supporting analysis for the operational strategy for core cooling during the ELAP concurrent with LUHS.

- Core cooling is maintained
- No fuel failures

The fulfillment of these criteria is determined by evaluating RCS key parameters such as RCS and SG pressures, RCS temperature, collapsed levels in reactor vessel, core, and SG.

A.4 Analysis Condition and Assumption

The following analysis conditions and assumptions are selected according to the requirements of NEI 12-06, Section 3.2.1.

- The full-power operation is selected as a representative case for setting up the APR1400 FLEX strategy of the modes 1 through 4 and mode 5 operation with SGs available.
- The plant is assumed to operate at 100 percent power with no uncertainty for system parameters. The initiating event is assumed to be an ELAP concurrent with LUHS.
- The reactor is assumed to be tripped automatically by the low reactor coolant pump speed trip of the RPS since the RCPs could not be provided with ac power.
- The MSSVs are assumed to actuate automatically when the SG pressure exceeds the MSSV setpoints.

- RCP seal leakage is assumed to be 94.64 L/min (25 gpm) per RCP at the initial RCS pressure of 158.19 kg/cm²A (2,250 psia) and naturally reduce as the RCS pressure decreases during the event. This causes loss of RCS inventory, which should be adequately maintained for preventing core uncover leading to core failure.
- The TDAFWPs are assumed to start automatically on receipt of AFAS signal.
- The decay heat conditions of ANSI/ANS-5.1-1979 are used for best-estimate simulation of the FLEX strategy.
- Operator is assumed to cool down the RCS by controlling MSADVs with a rate of 27.78 °C/hour (50 °F/hour) from 8 hours following the BDBEE.
- The auxiliary charging pump (ACP) is assumed to supply borated water at the constant value of 166.56 L/min (44 gpm) for RCS makeup after 8 hours following the event. If ACP is unavailable, a primary high-head FLEX pump is used for providing adequate water to maintain RCS inventory.
- Four safety injection tanks (SITs) inject 4,000 ppm borated water into the RCS when the RCS pressure decreases below the setpoints as designed.
- Normal feedwater flow to SGs is assumed to stop at the initiation of the BDBEE. Auxiliary feedwater flow supplies water to SGs and is controlled to maintain SG level within the control band of 25 percent to 40 percent

A.5 Analysis Results

A.5.1 Full-Power Operation

The APR1400 core cooling capability under the BDBEE, ELAP concurrent with LUHS, is analyzed using RELAP5/Mod 3.3 code, according to the full-power operational strategy consisting of the following three phases as described in Subsection 5.1.2.3.1.

- Phase 1: 0 to 8 hours
- Phase 2: 8 to 72 hours
- Phase 3: Indefinite time period following Phase 2

For the full-power operation case, two types of core cooling strategies, which are basic operational strategy and contingency plan, are analyzed. In the basic strategy, the RCS is cooled down to hot shutdown using both installed plant equipment, such as TDAFWP and ACP, and FLEX equipment such as the mobile GTG. The contingency plan is prepared in case installed plant equipment is inoperable even after connection of mobile ac power. In this case, RCS is cooled down to cold shutdown using the secondary side FLEX pump. RCS makeup is carried out by the primary side high-head FLEX pump. Table A-1 summarizes the sequence of events during the ELAP/LUHS coping operation.

A.5.1.1 Core Cooling – Full-Power Operation Basic Strategy of RCS Cooldown (Using Installed Pumps)

Figures A-1 through A-9 show the primary and secondary thermal-hydraulic behaviors for the basic

strategy using installed equipment.

Figure A-1 shows RCS and SG pressures and Figure A-2 shows RCS temperatures during the accident. These figures demonstrate the NCC operation of each step such as maintaining hot standby conditions, cooling down the RCS, and maintaining hot shutdown conditions. While RCS pressure decreases by secondary cooldown, the SIT starts to inject borated water when the RCS pressure reaches to the SIT actuation setpoint (Figure A-3). The ACP flow starts at 8 hours when the mobile GTG is assumed to be connected, and the flow rate is well balanced with the RCP seal leakage in the hot shutdown period (Figures A-4 and A-5).

As shown in Figure A-6, PZR level decreases and stays at an empty state for a long time. This is because the liquid volume of RCS decreases due to the RCP seal leakage and shrinkage of RCS inventory. However, the core and downcomer water level is recovered after SIT flow injection, and then stabilized after 32 hours when the ACP flow becomes balanced with the RCP seal leakage.

Because of the RCS inventory makeup by SIT and ACP, the decreased core level is also restored, as shown in Figure A-7. Even though the core level reduces a little during the cooldown period, it still covers the active core. This means that the fuel is not uncovered and fuel integrity is preserved. The cladding temperature of the active core shown in Figure A-8 also shows that the fuel integrity is maintained during the accident.

Figure A-9 shows MSSV and MSADV flows during the accident. The MSSV relieves the steam generated by the decay heat of the core from SG and thus maintains the SG pressure at a constant value during the hot standby condition, whereas the MSADV is used for cooling the RCS and maintaining it at hot shutdown condition.

As shown in Figure A-10, the total mass of AFW flow provided during the 72 hours is about 2,513.51 m³ (664,000 gal), which is still below the design value of the two AFWSTs inventory.

The AFWST and the raw water tank (RWT) can be used as onsite water sources to feed the SGs, and the number of onsite water sources is sufficient for NCC operation during Phases 1 and 2.

A.5.1.2 Core Cooling – Full-Power Operation Contingency Plan (Using FLEX Pumps)

For the contingency plan using FLEX equipment, the analysis results are provided in Figures A-11 through A-20.

Figure A-11 shows RCS and SG pressures and Figure A-12 shows RCS temperatures during the accident. These figures demonstrate the coping operation of each step of NCC operation for maintaining hot standby condition, cooling down the RCS to hot shutdown condition, further cooldown to the SG pressure of 1.03 kg/cm²A (14.7 psia), and maintaining the RCS at cold shutdown.

During the RCS cooldown operation, the system pressure decreases due to RCP seal leak and shrinkage. SIT starts to inject borated water when the RCS pressure reaches the SIT actuation setpoint (Figure A-13).

The high-head primary FLEX pump makes up the RCS inventory at the flow rate of 189.27 L/min (50 gpm) from 8 hours following the event, and the makeup flow rate becomes balanced with the RCP seal leakage in the cold shutdown period (Figures A-14 and A-15). The PZR level starts to increase at around 12 hours due to the makeup flow from the FLEX pump, and becomes stabilized at around 17 hours when the FLEX pump flow is balanced with the RCP seal leakage, as shown in Figure A-16.

Because of the RCS inventory makeup from SIT and the FLEX pump, the decreased core level is also restored, as shown in Figure A-17. The core is not uncovered and fuel integrity is preserved. The cladding

temperature of the active core shown in Figure A-18 also shows that the fuel integrity is maintained during the event.

Figure A-19 shows MSSV and MSADV flow during the event. The MSSV relieves the steam generated by the decay heat of core and thus maintains the SG pressure at a constant value during the hot standby conditions, whereas the MSADV is used for cooling the RCS and maintaining the SG pressure at 1.03 kg/cm²A (14.7 psia).

Figure A-20 shows that the total mass of AFW flow supplied during the 72 hours is about 2,839 m³ (750,000 gal), which is still below the design value of the two AFWSTs inventory.

Therefore, it is concluded that the APR1400 operational strategy for core cooling under simultaneous ELAP and LUHS provides reasonable assurance the appropriate core cooling and fuel integrity during the BDBEE.

The plant can be maintained at hot standby condition without operator action during Phase 1 (0 to 8 hours following the BDBEE). During the phase 2 (8 to 72 hours), the plant can be cooled down to hot shutdown or cold shutdown state depending on the type of coping strategy.

The safe shutdown state is maintained with onsite water for feeding SGs and fuel for GTGs until the end of Phase 2, and it is also continued by the water source and fuel supplied from offsite resources in Phase 3.

A.5.1.3 Subcriticality – Full-Power Operation FLEX Strategy

During the RCS cooldown by NCC, subcriticality of the core is maintained by not only the reactor scram but also the injection of borated water by the ACP, the primary FLEX pump, and SIT flow. The subcriticality analysis is performed for the contingency plan among the above two types of full-power operation FLEX strategy. The reason is that this case is more conservative than the other case, because the RCS is further cooled down in the contingency plan. Figure A-21 shows that the borated water injection flow provides negative reactivity sufficient to maintain the core at subcriticality in spite of the positive reactivity feedback due to the moderator temperature coefficient (MTC) and Doppler coefficient. Figure A-22 shows the reactivity behavior in the case of no RCP leakage, which is a worse condition with respect to criticality. Even in this case, the borated water injection flow also provides negative reactivity sufficient to maintain the core at subcriticality.

A.5.2 Lower-Power Operation and Shutdown Conditions with SGs Available

The APR1400 FLEX strategies and their coping capabilities against ELAP concurrent with LUHS during low-power operations and shutdown conditions are described for the following two categories of operation modes.

- Operation mode 1 through 3 with SGs available
- Operation mode 4 and mode 5 with SGs available

A.5.2.1 Coping Capability – Mode 1 through Mode 3

The NCC analysis result for ELAP and LUHS at full power is still valid for the mode 1 through 3 operations, i.e., lower-power operation, startup, and hot standby conditions, because it covers various states of the plant including full-power operation through hot shutdown condition. Therefore, the same FLEX strategy as in the full-power operation can be also applied to the mode 1 through mode 3

operations.

A.5.2.2 Coping Capability – Mode 4 and Mode 5 with SGs Available

In the operation mode 4 and 5 with SGs available, the SCS normally maintains the RCS between 176.67 °C(350 °F) (hot shutdown) and 54.44 °C (130 °F) (cold shutdown), while the SGs are still available. If the event of ELAP concurrent with LUHS occurs during these operation modes, the RCS is heated up and pressurized due to loss of residual heat removal function of the SCS.

If the RCS temperature is initially below the maximum RCS temperature requiring the LTOP, i.e., 136.11 °C (277 °F), the RCS pressure can be maintained below the LTOP limiting pressure of 43.94 kg/cm²A (625 psia) (20 percent of the RCS hydraulic test pressure of 219.71 kg/cm²A [3,125 psia]), because the LTOP relief valve installed in the SCS automatically opens at the opening setpoint (38.30 kg/cm²A [530 psig]).

After the RCS temperature increases to the LTOP disable temperature (136.11 °C [277 °F]), the operator tries to isolate the RCS from the SCS, by manually closing the SCS isolation valves. The operator action for isolation of the SCS is finished before the RCS temperature exceeds the SCS entry temperature (176.67 °C [350 °F]). After that, the RCS overpressurization can be protected by POSRVs.

After closing the SCS isolation valves, the RCS temperature and pressure continue to increase, and eventually the RCS returns to the hot standby condition. Then, the SG side feed-and-bleed operation can start cooling down the RCS, as described for the baseline cooling capability for ELAP and LUHS at full-power operation. Consequently, the full-power FLEX strategy can be also applied after the plant returns to hot standby condition.

Supporting analysis to confirm the above scenario has been performed under the assumption that the RCS has been cooled down to the refueling temperature of 54.44 °C (130 °F), while RCS pressure is kept at the SCS entry pressure of 31.64 kg/cm²A (450 psia). The initial RCS pressure and temperature are selected as a conservative combination in the cold shutdown operation range with respect to LTOP. The initial pressurizer level is 30 percent, which is the normal operating level during the low-mode operation.

Figure A-23 and A-24 show the analysis result for the RCS pressure and temperature during the event, respectively. After the shutdown cooling pump (SCP) stops at time zero, RCS pressure and temperature increase due to loss of residual heat removal function of SCS. However, the increasing rate of the RCS pressure becomes much slower at around 30 minutes, when the LTOP valve opens to mitigate the low-temperature overpressurization (Figure A-25). On the other hand, RCS temperature continues to increase, and reaches the LTOP disable temperature of 136.11 °C(277 °F) at around 2.3 hours. It can be seen that RCS pressure is maintained well below the LTOP limiting pressure of 43.94 kg/cm²A (625 psia) until the RCS temperature reaches the LTOP disable temperature. RCS pressure increases rapidly again at around 4 hours when the operator is assumed to isolate the SCS from the RCS.

Based on the analysis result, it is concluded that the RCS overpressurization is well protected by the LTOP valve installed in the SCS, until the SCS is isolated by the operator after the RCS temperature exceeds the LTOP disable temperature. The RCS returns to the hot standby condition (above 176.67 °C [350 °F]) at around 4 hours following the event, so that the operator can isolate the SCS from the RCS and conduct the cooldown operation according to the full-power FLEX strategy. Although the operator action for RCS cooldown is delayed, the RCS overpressurization is successfully limited by the cyclic opening of POSRVs.

Table A-1 Sequence of Events for Coping Operation Against ELAP/LUHS Occurred at Full-Power Operation

Event	Time	
	Case 1 (Basic strategy)	Case 2 (Contingency plan)
ELAP occurs	0 minute	
Reactor trip by low RCP speed trip	0 minute	
Commence manual RCS cooldown with MSADVs at a rate of 27.78 °C/hour (50 °F/hour)	8.0 hours	
SITs start to inject borated water into RCS	10.40 hours	10.15 hours
RCS hot-leg temperature reaches 176.67 °C (350 °F) (SCS entry condition)	12.78 hours	12.76 hours

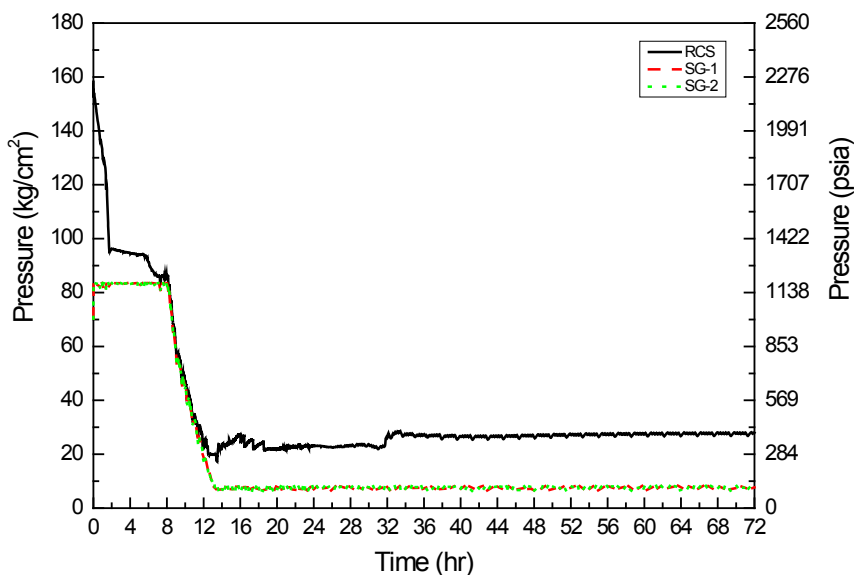

Figure A-1 RCS and Steam Generator Pressure (Basic Strategy)

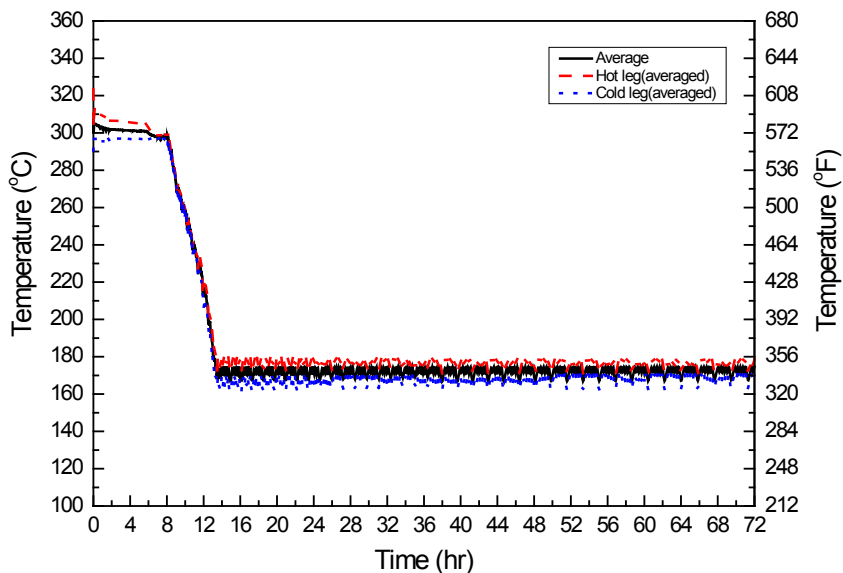

Figure A-2 RCS Temperature (Basic Strategy)

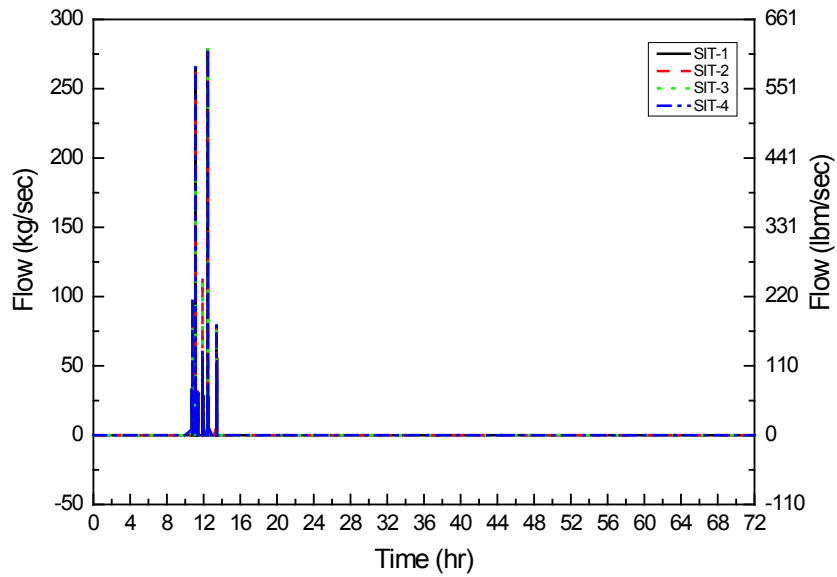

Figure A-3 SIT Flow (Basic Strategy)

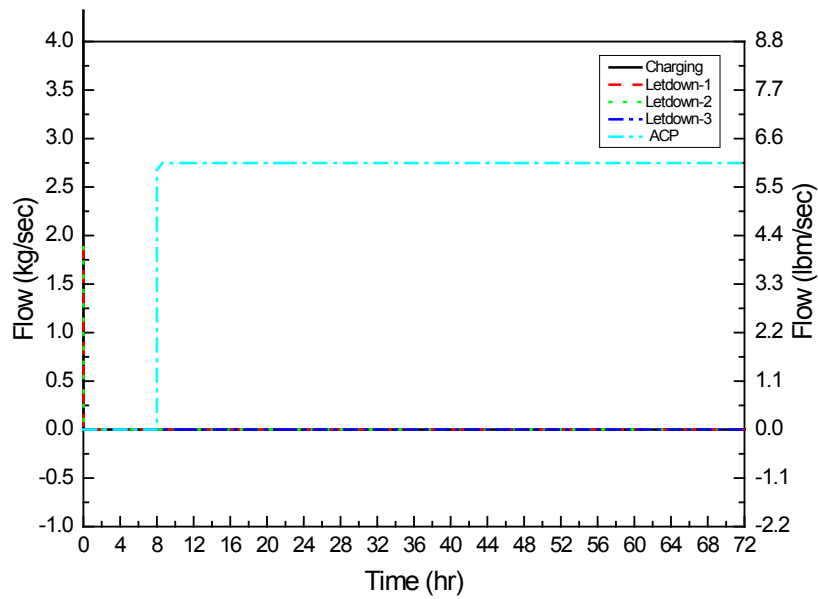

Figure A-4 ACP Flow (Basic Strategy)

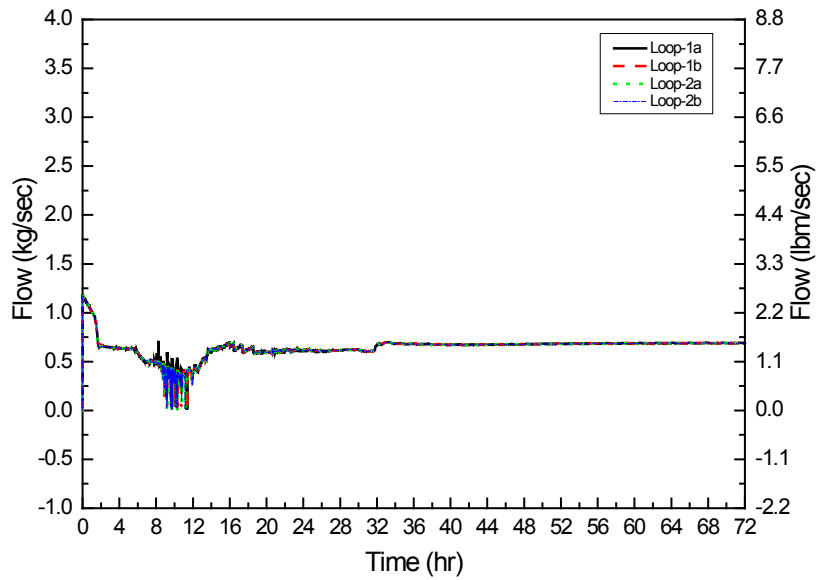

Figure A-5 RCS Leak Flow (Basic Strategy)

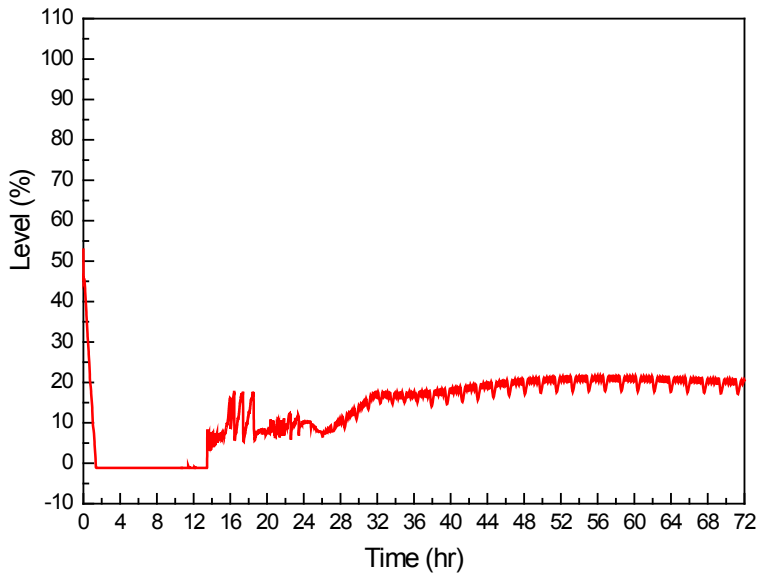

Figure A-6 RCS Pressurizer Water Level (Basic Strategy)

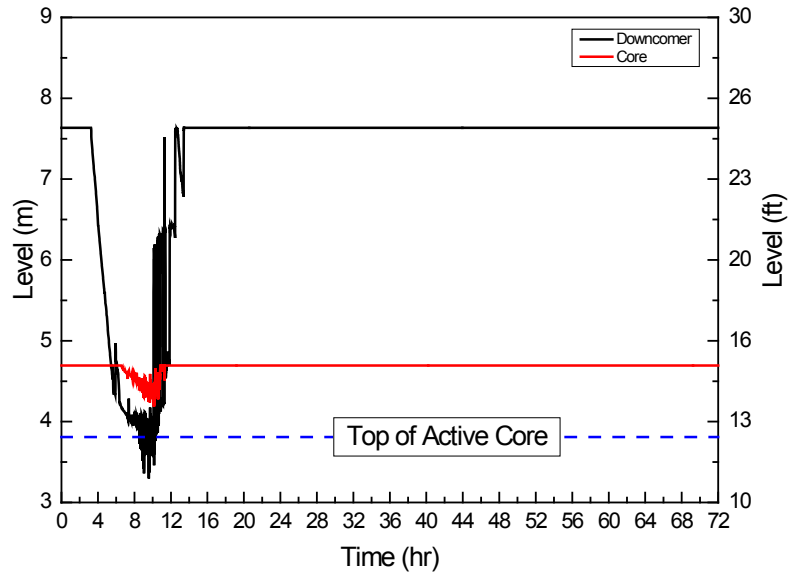

Figure A-7 Collapsed Downcomer and Core Level (Basic Strategy)

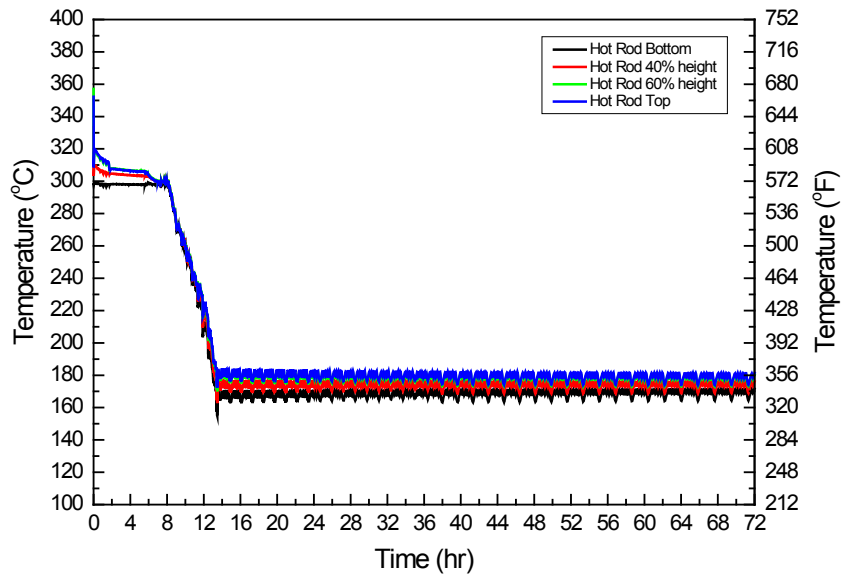

Figure A-8 Cladding Temperature (Basic Strategy)

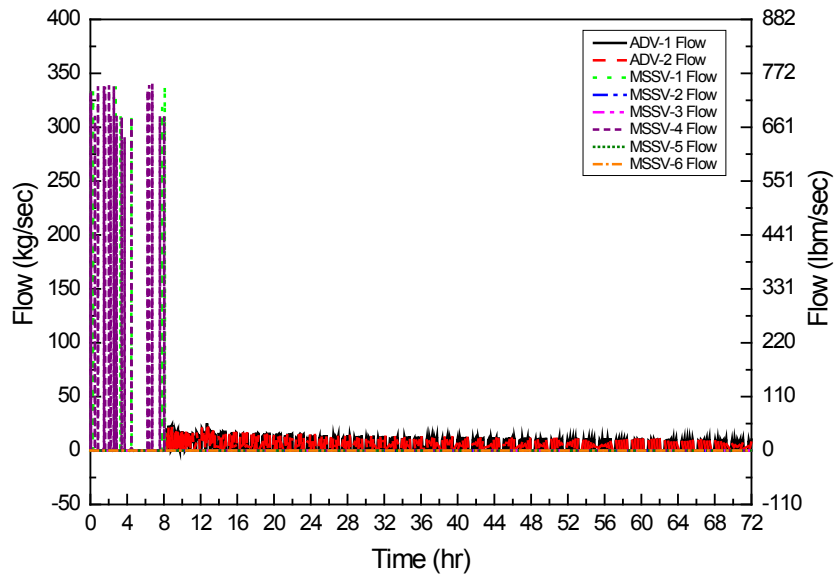

Figure A-9 MSADV, MSSV Flow (Basic Strategy)

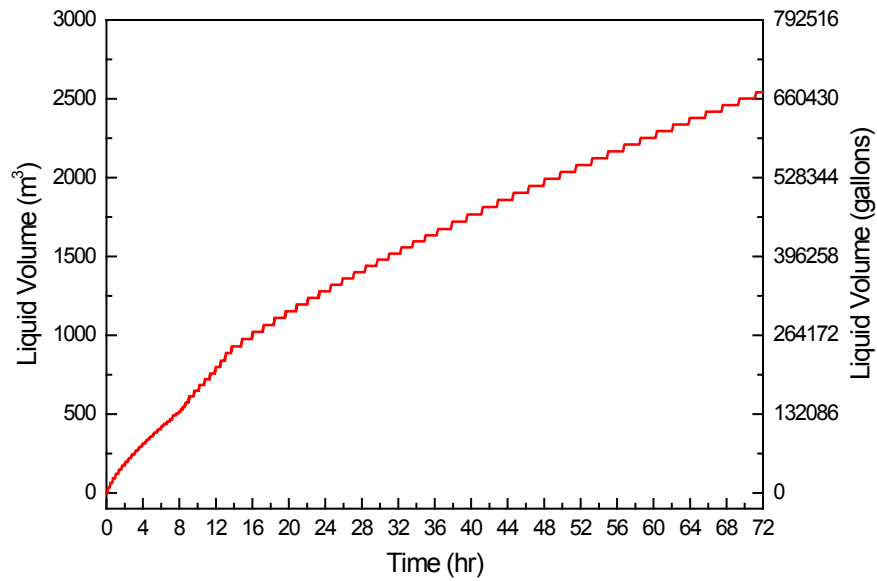

Figure A-10 Integration of AFW Flow (Basic Strategy)

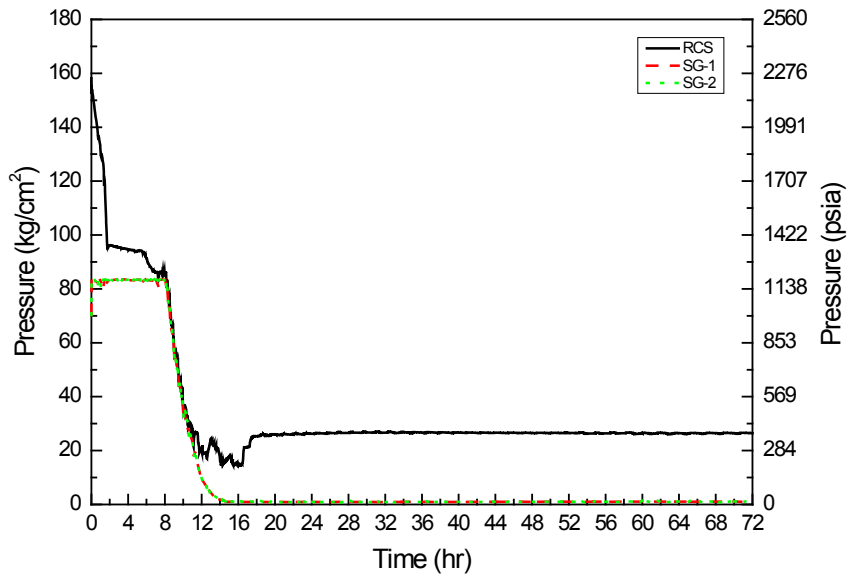

Figure A-11 RCS and Steam Generator Pressure (Contingency Plan)

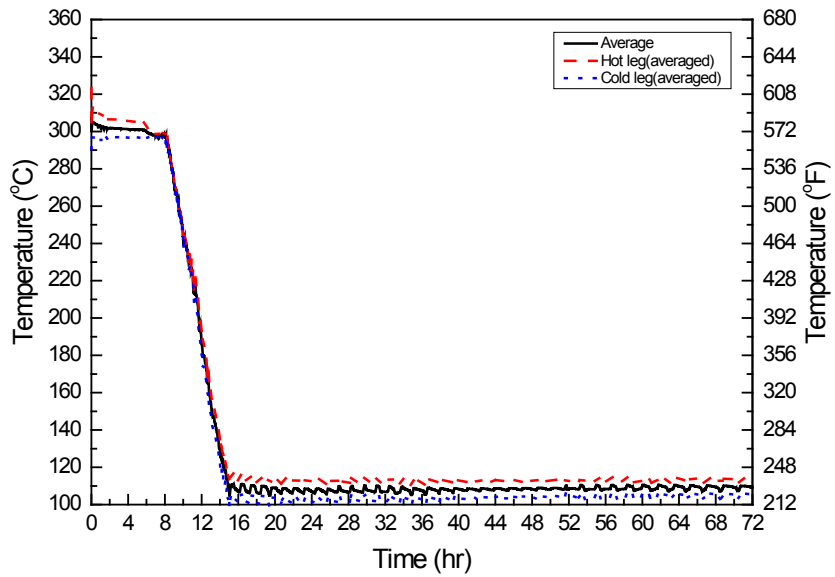

Figure A-12 RCS Temperature (Contingency Plan)

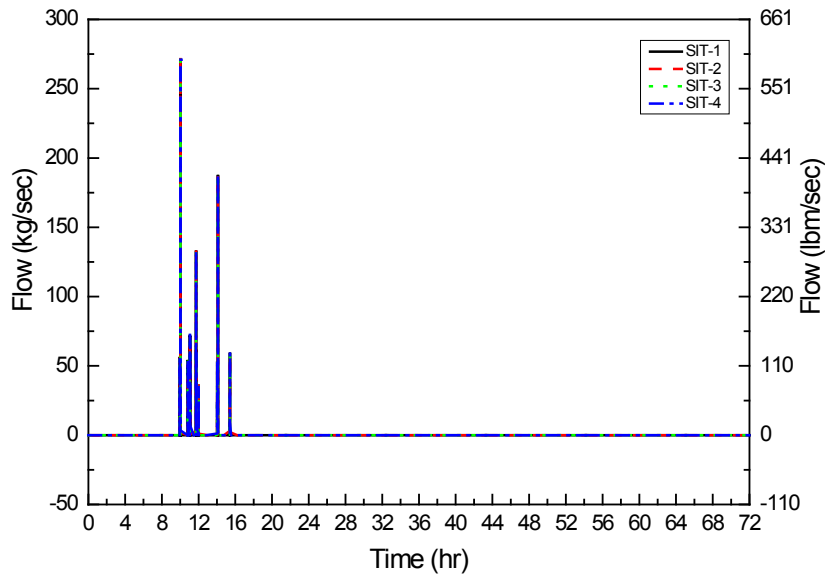

Figure A-13 SIT Flow (Contingency Plan)

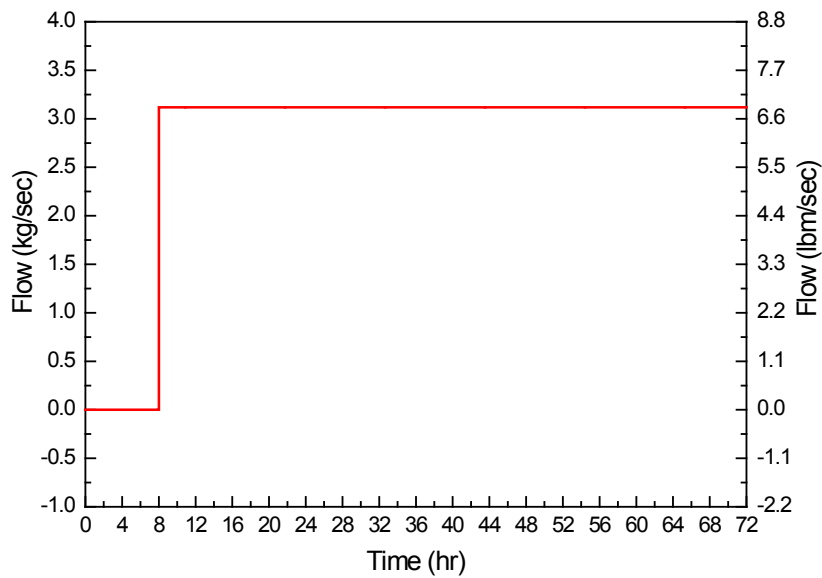

Figure A-14 Primary FLEX Pump Flow (Contingency Plan)

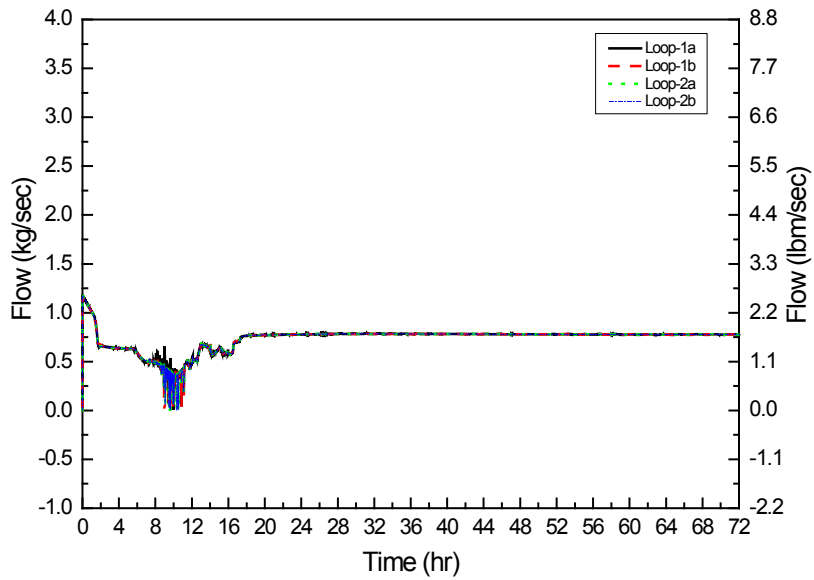

Figure A-15 RCS Leak Flow (Contingency Plan)

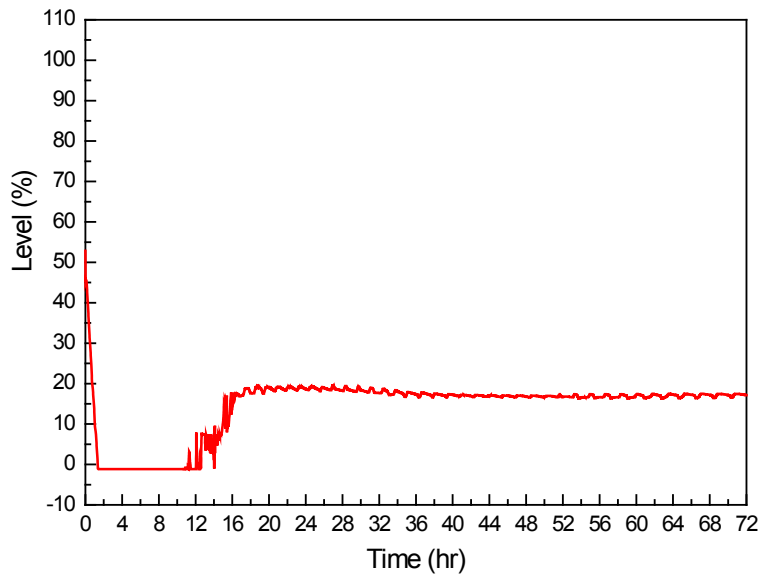

Figure A-16 Pressurizer Water Level (Contingency Plan)

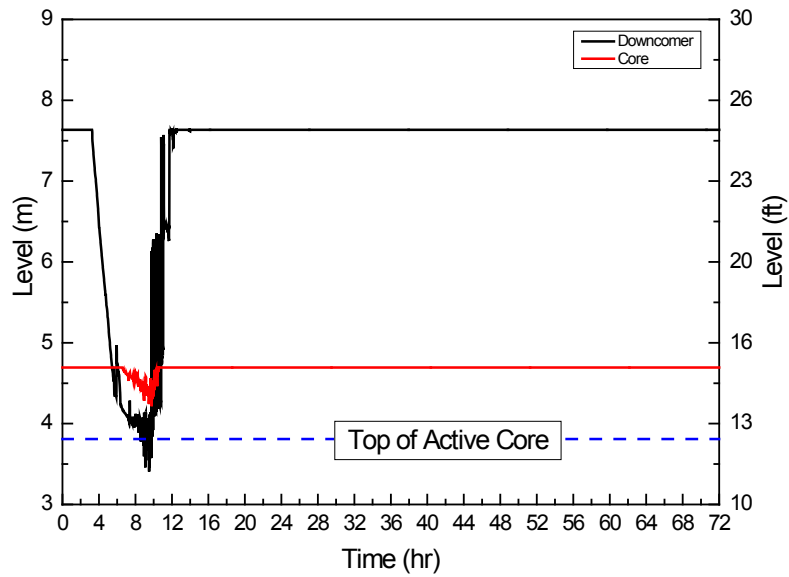

Figure A-17 Collapsed Downcomer and Core level (Contingency Plan)

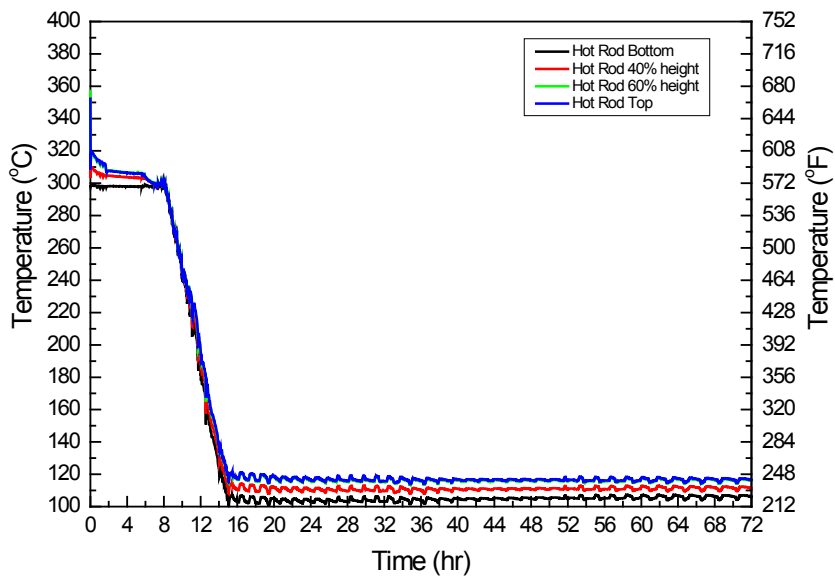

Figure A-18 Cladding Temperature (Contingency Plan)

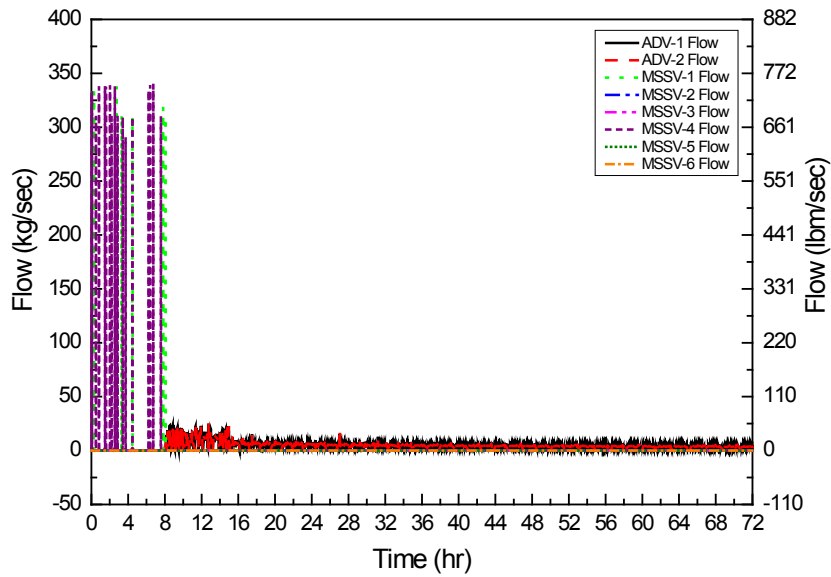

Figure A-19 MSADV, MSSV Flow (Contingency Plan)

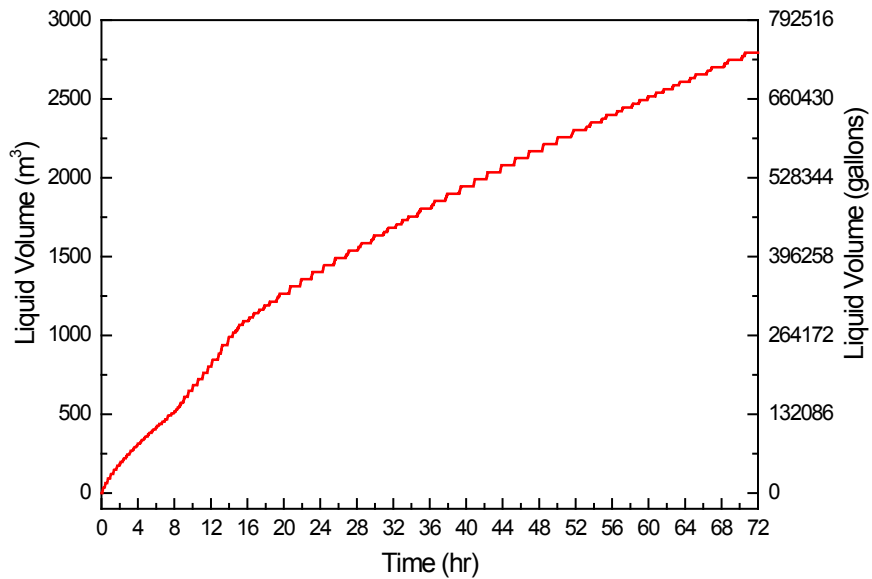

Figure A-20 Integration of AFW Flow (Contingency Plan)

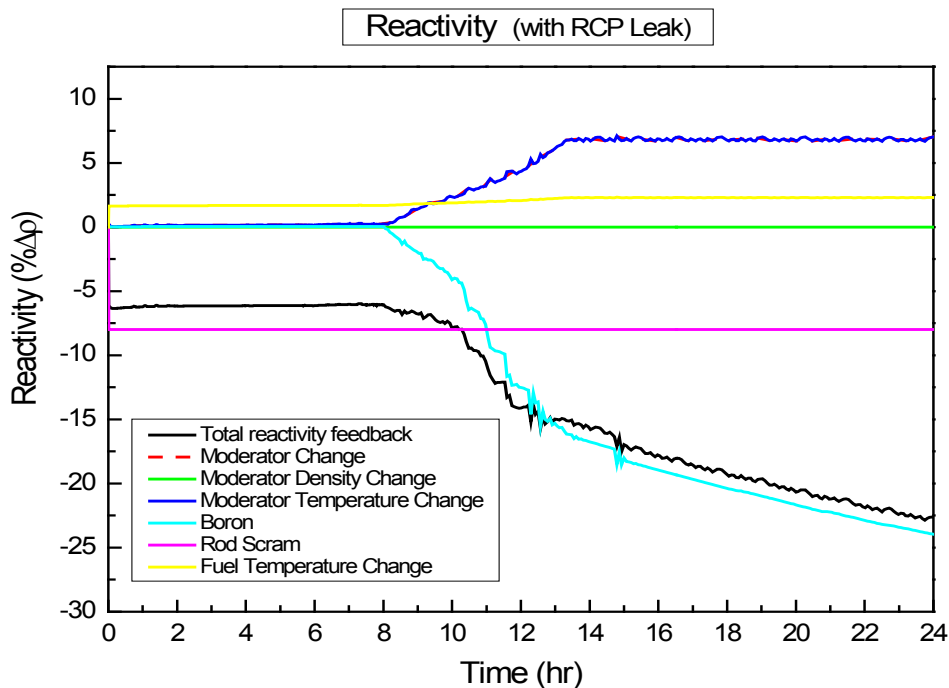

Figure A-21 Reactivity Changes during RCS Cooldown (with RCP Leak)

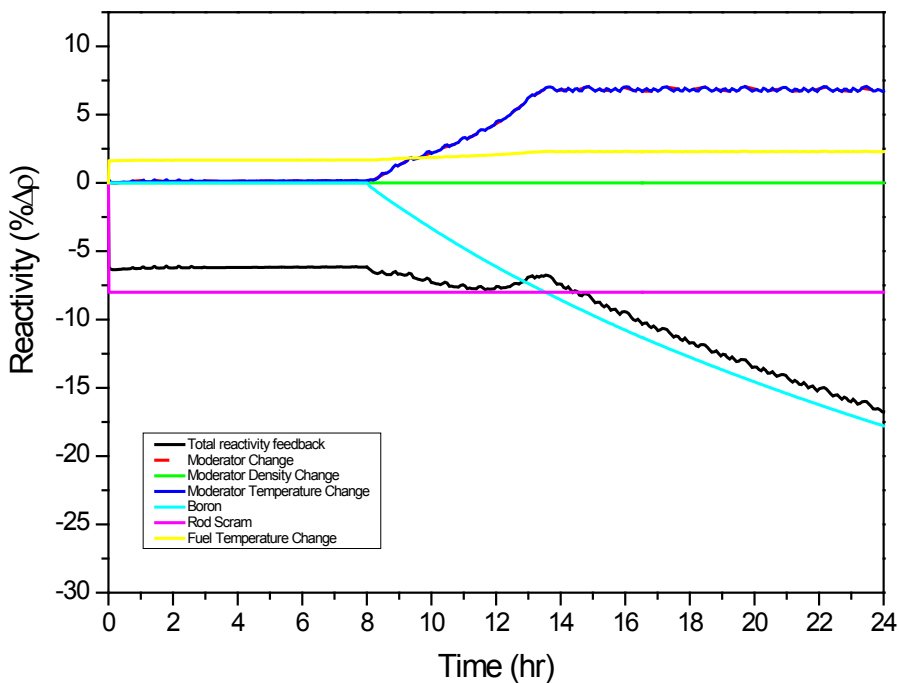

Figure A-22 Reactivity Changes during RCS Cooldown (No RCP Leak)



Figure A-23 RCS Pressure



Figure A-24 RCS Temperature

TS



Figure A-25 LTOP Valve Flow

APPENDIX. B

Spent Fuel Pool Time to Boil and Makeup Analysis

TABLE OF CONTENTS

B.1 ACCEPTANCE CRITERIA B1
B.2 KEY ASSUMPTIONS B1
B.3 METHODOLOGY B2
B.4 EVALUATION RESULTS B2

LIST OF TABLES

Table B-1 Time to Reach SFP Bulk Boiling and Input Parameters B4
Table B-2 Time to Reach SFP Water Level 2 and Level 3 B4
Table B-3 Required Makeup Volume and Water Source..... B5

LIST OF FIGURES

Figure B-1 Spent Fuel Pool Monitoring Water Level B6

APPENDIX.B Spent Fuel Pool Time to Boil and Makeup Analysis

The APR1400 SFP conditions are analyzed for the BDBEE concurrent with LUHS.

B.1 Acceptance Criteria

The following acceptance criteria based on NEI 12-06, Section 3.2.1 are applied to the supporting analysis for the operational strategy for SFP cooling during the ELAP:

- Fuel in the SFP remains covered.

B.2 Key Assumptions

The SFP time to boil and makeup analysis is performed using the following key assumptions and inputs:

- During an ELAP event, spent fuel cooling function by the spent fuel pool cooling system (SFPCS) heat exchangers is lost. Heatup of the SFP and boiling can be credited to cool the spent fuel, provided the water level is maintained above the top of the spent fuel rack.
- A conservative number of rack spaces are assumed with all rack spaces.
- Heat losses from the SFP are conservatively neglected.
- Three conditions analyzed for the SFP decay heat load are:
 - SFP decay heat load during mode 1 to mode 4 without full core offload. This is defined as the decay heat generated by one refueling batch offloaded from core after 100 hours following shutdown, plus the spent fuel assemblies accumulated from the previous refueling operations.
 - SFP decay heat load during mode 5 and mode 6 without full core offload.
 - SFP decay heat during mode 6 with full core offload (limiting case), which is defined as the decay heat generated by one full core offloaded after 100 hours following shutdown, plus the spent fuel assemblies accumulated from the previous refueling operations.
- Initial SFP temperature is assumed at the maximum as follows:
 - SFP decay heat during mode 1 to mode 6 with full core not offloaded: 48.9 °C (120 °F)
 - SFP decay heat during mode 6 with full core offload: 60 °C (140 °F)
- Initial SFP water level is assumed at EI 149 ft 0 in (elevation of SFP cleanup suction nozzle).
- SFP inventory makeup starts when the water level reaches Level 2 defined in NEI 12-02 and shown in Figure B-1.
- Water inventories
 - The water inventory above top of fuel rack: 816.3 m³ (28,826 ft³)
 - Total SFP inventory: 816.3 m³ (28,826 ft³)

- Monitoring water level

Based on Figure B-1, the following are the definitions of the water levels:

Level 1: Level adequate to support operation of the normal SFP cooling system

Level 2: Level adequate to provide substantial radiation shielding for a person standing on the SFP operating floor

Level 3: Level where fuel remains covered, but actions to implement makeup water addition should no longer be deferred

B.3 Methodology

The SFP time to boil and makeup analysis was performed to determine the bulk SFP heatup time and boiloff rate.

The SFP bulk heatup time is conservatively calculated using $\Delta t = MC_p \Delta T / Q$,

where,

M (lbm) is the mass of water in the SFP.

C_p (Btu/lbm°F) is the specific heat.

ΔT (°F) is the temperature rise.

Δt (hr) is the time to complete the temperature rise.

Q (Btu/hr) is the heat added to the SFP from the spent fuel stored in the pool.

The boiloff rate is calculated using: $\text{Boiloff Rate} = Q / h_{fg}$,

where,

Q (Btu/hr) is the heat added to the SFP from the spent fuel stored in the pool.

h_{fg} (Btu/lbm) is the latent heat of evaporation.

B.4 Evaluation Results

The evaluation results for the SFP time to boil and makeup water analysis are summarized in Tables B-1 through B-3. Based on Tables B-1 and B-2, the following inference can be drawn:

- For modes 1 to mode 6 with full core not offloaded, SFP boiling occurs approximately 5.4 hours after an ELAP. As a result of boiling, SFP level reaches 3.05 m (10 ft) of water above the irradiated fuel assemblies in approximately 33.1 hours after an ELAP. Within 33.1 hours, Phase 2 actions should be initiated to provide makeup water to the SFP from the RWT using the portable pump.
- For mode 6 with maximum SFP heat loads due to a full core offload, the time to boil is reduced to 2.0 hours after an ELAP. As a result of boiling, SFP level reaches 3.05 m (10 ft) of water

above the irradiated fuel assemblies in approximately 15.36 hours after an ELAP. Within 15.36 hours, Phase 2 actions should be initiated to provide makeup water to the SFP from the RWT using the portable pump.

- In a postulated ELAP, the required SFP makeup flow rate to match the boiloff for modes 1 through 6 with core not offloaded is 237.7 L/m (62.79 gpm), and the SFP makeup flow rate for mode 6 with the full core offload is 493.2 L/min (130.3 gpm).

Table B-1 Time to Reach SFP Bulk Boiling and Input Parameters

MODE Parameter	Mode 1~6 (with no full core offload)	Mode 6 (with full core offload)
Initial water temperature, °C (°F)	48.9 (120)	60 (140)
Water density, kg/m ³ (lbm/ft ³)	958.4 (59.83)	958.4 (59.83)
Water volume, m ³ (ft ³)	816.3 (28,826)	816.3 (28,826)
Specific heat, kcal/kg-°C (Btu/lb-°F)	1.0 (1.0)	1.0 (1.0)
Heat load, MW (MBtu/hr)	8.55 (29.2)	17.75 (60.6)
Temperature increase rate, hr/°C (hr/°F)	0.11 (0.06)	0.05 (0.03)
Temp. difference to boiling, °C (°F)	51.1 (92.00)	40.0 (72.00)
Time to boiling (hours)	5.4	2.0

Table B-2 Time to Reach SFP Water Level 2 and Level 3

MODE Parameter	Mode 1~6 (with no full core offload)	Mode 6 (with full core offload)
Density at 100 °C (212 °F), kg/m ³ (lb/ft ³)	958.4 (59.83)	958.4 (59.83)
Latent heat of water, kJ/kg (Btu/lb)	2,252 (969)	2,252 (969)
Boiloff rate, kg/hr (lb/hr)	13,669 (30,134)	28,367 (62,539)
Boiloff rate, L/min (gpm)	237.7 (62.79)	493.2 (130.3)
Time to Level 2 (3.05 m [10 ft] above fuel rack top), (hours)	33.1	15.36
Time to Level 3 (above fuel rack top), (hours)	62.7	29.6

Table B-3 Required Makeup Volume and Water Source

M		Mode 1~6 ^(Note 1) (with no full core offload)	Mode 6 (with full core offload)
ODE Parameter		RWT	RWT
Water source		RWT	RWT
Total volume, m ³ (gal)		9,993.49 (2,640,000)	9,993.49 (2,640,000)
Available volume for SFP makeup during total coping time, m ³ (gal)		3,443 (909,654)	9,993.49 (2,640,000)
Makeup during 72 hours	Time for makeup (72 hours minus time to 3.05 m [10 ft] above fuel rack top), (hours)	38.95	56.64
	Required makeup volume, m ³ (gal)	555.46 (146,737)	1,676 (442,883)
Makeup during 11 days (264 hours)	Time for makeup (11 days minus time to 3.05 m [10 ft] above fuel rack top), (hours)	230.95	248.64
	Required makeup volume, m ³ (gal)	3,294 (870,114)	7,359(1,944,138)
Total coping Time		11.4 days	14.7 days

(Note 1): RWT can be used as the water source for NCC operation through TDAFWP and SFP makeup during modes 1 through 5 operation with SGs available. However, COL applicants are responsible for determining the available volume of SFP makeup and coping time during modes 5 and 6 with SGs unavailable.

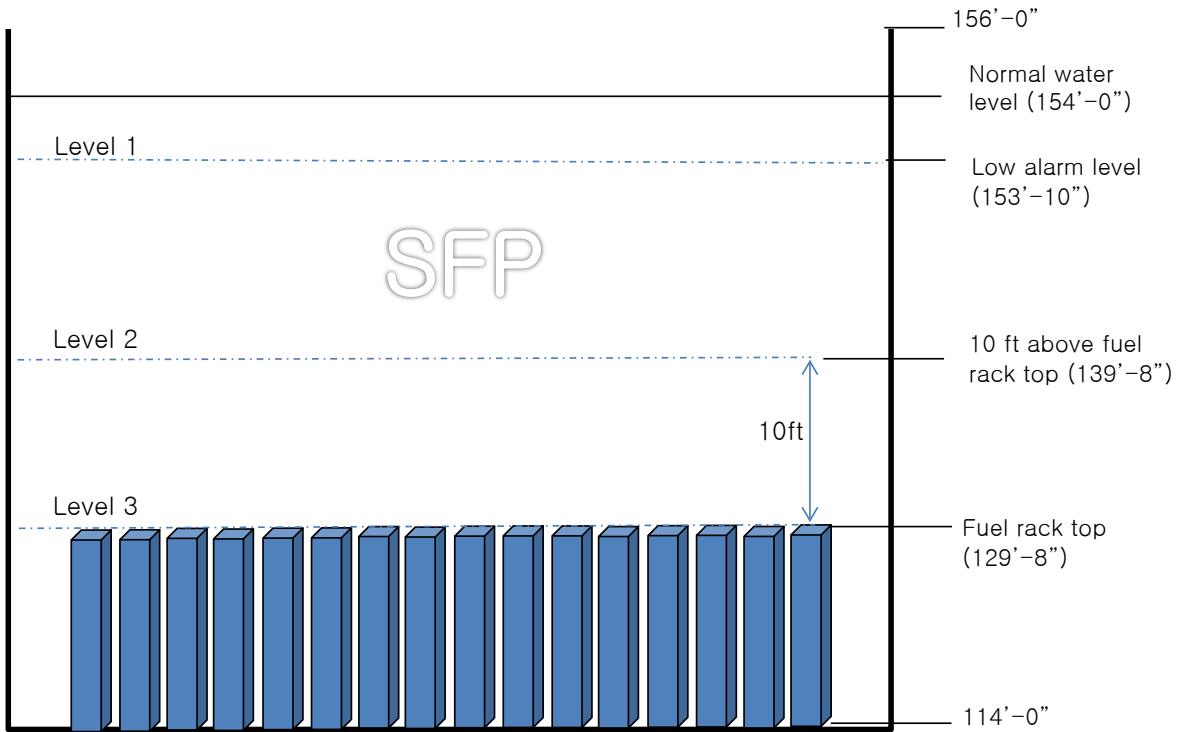

Figure B-1 Spent Fuel Pool Monitoring Water Level

APPENDIX. C

480 V and 4.16 kV Mobile GTG Electrical Loadings

APPENDIX.C 480 V and 4.16 kV Mobile GTG Electrical Loadings

The tables below provide a detailed estimate of electrical loading for the 480 V and 4.16 kV mobile GTGs as described in Subsection 5.1.2.6.

Table C-1 480 V Mobile GTG Electrical Loadings (1 of 2)

TS

Table C-1 480 V Mobile GTG Electrical Loadings (2 of 2)

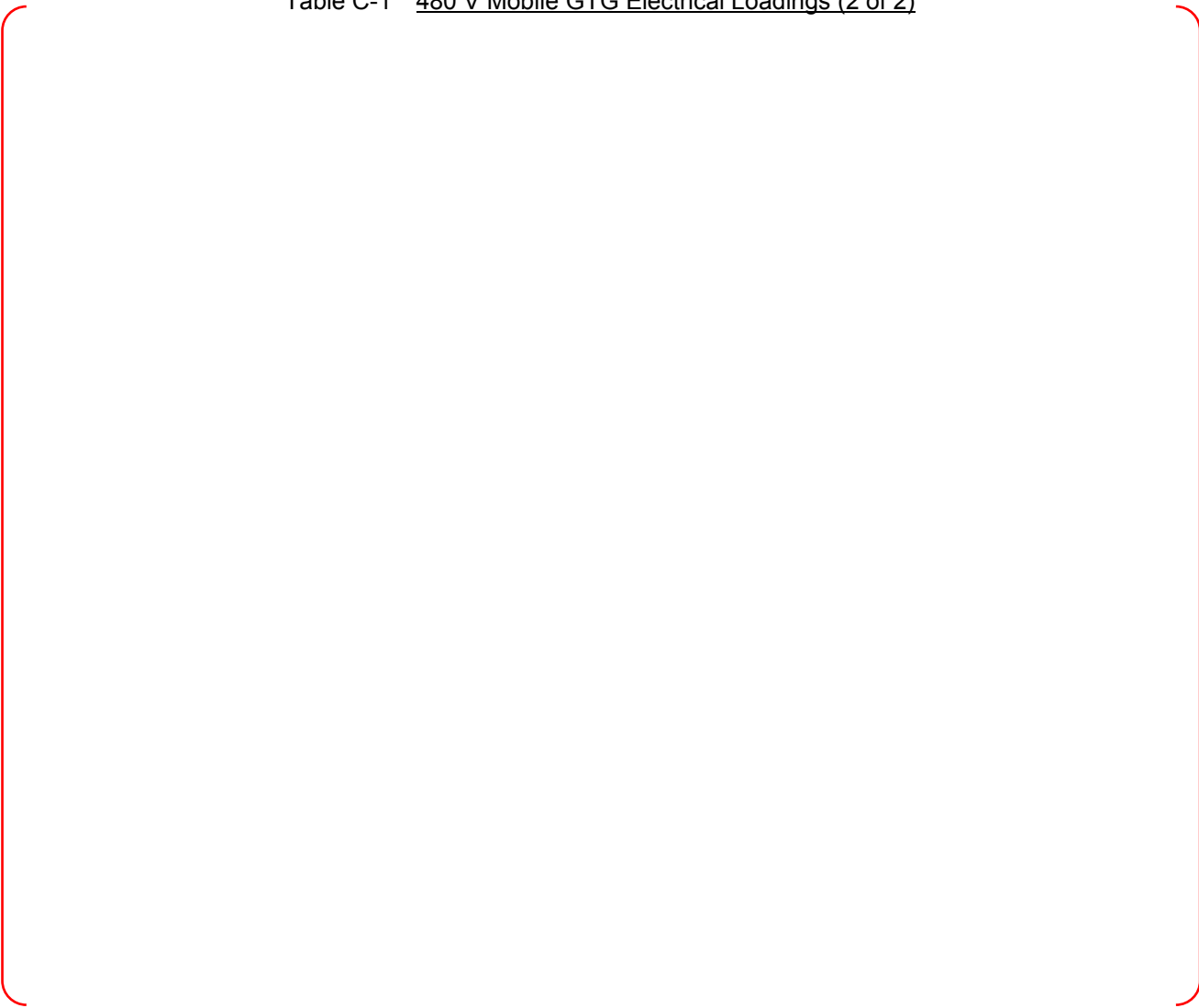

Table C-2 4.16 kV Mobile GTG Electrical Loads (1 of 6)

TS



Table C-2 4.16 kV Mobile GTG Electrical Loads (2 of 6)

TS



Table C-2 4.16 kV Mobile GTG Electrical Loads (3 of 6)

TS

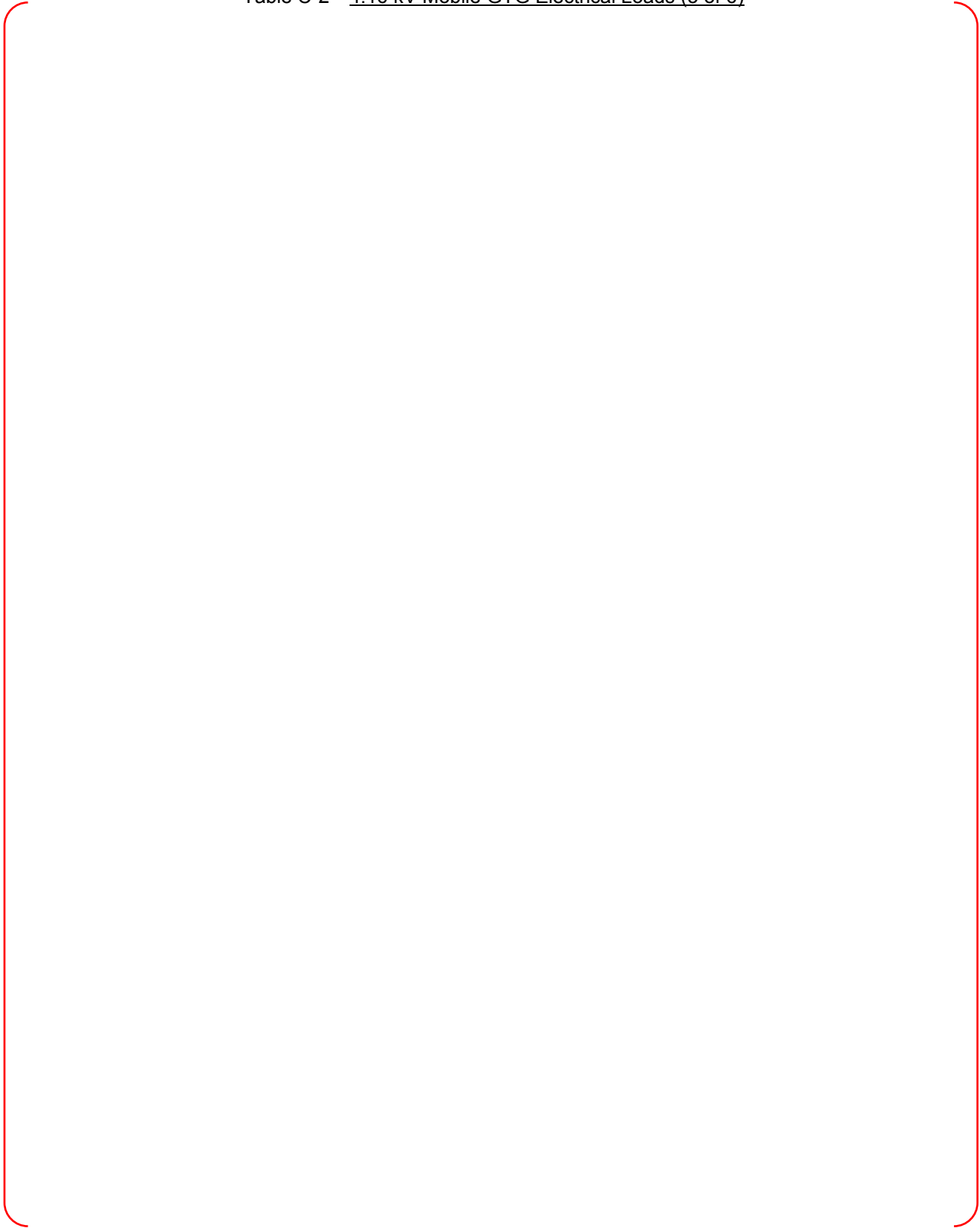

Table C-2 4.16 kV Mobile GTG Electrical Loads (4 of 6)

TS

Table C-2 4.16 kV Mobile GTG Electrical Loads (5 of 6)

TS



Table C-2 4.16 kV Mobile GTG Electrical Loads (6 of 6)

TS

