

January 8, 1998

IA 98-001

Mr. Albert M. Nardslico, Jr.
[HOME ADDRESS DELETED
UNDER 10 CFR 2.790]

SUBJECT: PREDECISIONAL ENFORCEMENT CONFERENCE
(NRC Investigation Report No. 1-96-015)

Dear Mr. Nardslico:

This is in reference to an investigation conducted by the NRC's Office of Investigations (OI) involving wrongdoing associated with the fitness-for-duty (FFD) testing computer program at the Nine Mile Point Nuclear Station. The purpose of the investigation was to determine who altered the Niagara Mohawk Power Corporation's (NMPC) FFD computer program, enabling certain individuals to be excluded from random drug testing. The investigation found that you and one other computer programmer intentionally altered the FFD computer program. A copy of the investigation synopsis is enclosed.

Based on our review of the investigation report, an apparent violation of the NRC's rule prohibiting deliberate misconduct, 10 CFR 50.5(a)(1), was identified. This rule prohibits licensee employees or contractors from engaging in deliberate misconduct that causes a licensee to be in violation of any rule or regulation. In this case, altering the FFD computer program to exclude certain individuals from random drug testing was a violation of 10 CFR 26.24 which requires that individuals be tested in a statistically and unpredictable manner.

On December 8, 1997, the conclusions of the investigation were discussed with you by Mr. Lawrence Doerflein of this office. During that discussion, you were asked if you wanted a predecisional enforcement conference prior to the NRC determining the appropriate enforcement action to take. You stated you wanted to discuss the matter with your lawyer before making that decision, and that you would get back to the NRC. On December 29, 1997, Mr. Doerflein left a message on your work voice mail inquiring about your decision. As of the date of this letter, the NRC has not been informed of your decision.

Therefore, the purpose of this letter is to inform you that, unless you inform the NRC within seven days after receipt of this letter that you want a predecisional enforcement conference to discuss the apparent violation noted above, the NRC will proceed with enforcement action. You can inform Mr. Doerflein at 610-337-5378 of your decision.

CERTIFIED MAIL
RETURN RECEIPT REQUESTED



IE151

9801160067 980108
PDR ADOCK 05000220
Q PDR

OFFICIAL RECORD COPY

IE-01



For your information, if you decide you want a conference, it would be predecisional because the NRC has not made a final determination that violations of NRC requirements occurred or that enforcement action will be taken against you. The purpose of the conference, which would be transcribed, would be to discuss the apparent violation and the circumstances surrounding it, and to give you an opportunity to provide your perspective on this issue and any other information that you believe is relevant to the NRC's enforcement determination. You are specifically invited to address the factors that the NRC would consider in determining whether enforcement action should be taken against you. These factors are described in Section VIII, Enforcement Actions Involving Individuals, of the enclosed copy of the "General Statement of Policy and Procedures for NRC Enforcement Actions," NUREG-1600.

If the NRC concludes that you deliberately caused or committed a violation of NRC requirements, the possible sanctions include a Notice of Violation, a civil penalty,¹ or an order. An order may prohibit involvement in NRC-licensed activities, require notice to the NRC before resuming involvement in NRC-licensed activities, or require other action. Accordingly, if you decide you want a predecisional enforcement conference, you should be prepared to address why NRC should not issue you an Order removing you from licensed activities.

Although not required, you may provide the NRC a written reply to the apparent violation prior to or during the conference. In addition, you may have an attorney or personal representative attend the conference but it should be understood that the NRC will address its questions to you.

You will be advised by separate correspondence of the results of our deliberations on this matter. No response regarding the apparent violation is required at this time. Should you have any questions about this letter or the conference, please contact Mr. Doerflein.

¹ Civil penalties are not normally imposed on unlicensed individuals. See Footnote 10 of the NRC Enforcement Policy.



Albert M. Nardslico, Jr.

3

In accordance with 10 CFR 2.790 of the NRC's "Rules of Practice," a copy of this letter, with your home address removed, and Enclosure 1 will be placed in the NRC Public Document Room. However, the NRC will delay placing a copy of this letter and Enclosure 1 in the NRC Public Document Room (PDR) until an enforcement decision has been made. At that time, in accordance with 10 CFR 2.790 of the NRC's "Rules of Practice," a copy of this letter, with your home address removed, and Enclosure 1 will be placed in the PDR.

Sincerely,

Original Signed by:

Charles W. Hehl, Director
Division of Reactor Projects

Docket Nos. 50-220, 50-410
License Nos. DPR-63, NPF-69

Enclosures:

1. Synopsis, OI 1-96-015
2. NRC Enforcement Policy
3. 10 CFR 50.5(a)(1)
4. 10 CFR 26.24

cc w/encls:

Mr. B. Ralph Sylvia, Executive Vice President and Chief Nuclear Officer



Albert M. Nardslico, Jr.

4

Distribution w/encls:

Region I Docket Room (w/concurrences)
H. Miller, RA/W. Axelson, DRA (1)
D. Screnci, PAO
Region I Docket Room (with concurrences)
Nuclear Safety Information Center (NSIC)
NRC Resident Inspector
L. Doerflein, DRP
R. Junod, DRP

Distribution w/encls: (VIA E-MAIL)

M. Leach, RI EDO Coordinator
R. Zimmerman, ADPR, NRR
F. Davis, NRR
A. Nicosia, NRR
J. Lieberman, OE (OE MAIL)
T. Reis, OE
D. Holody, OE, RI
T. Walker, SES, RI
B. Norris - Nine Mile Point
S. Bajwa, NRR
D. Hood, NRR
M. Campion, RI
Inspection Program Branch (IPAS)

DOCUMENT NAME: G:\BRANCH1\196015.PEC

To receive a copy of this document, indicate in the box: "C" = Copy without attachment/enclosure "E" =
Copy with attachment/enclosure "N" = No copy

OFFICE	RI/DRP	RI/EO	RI/OI	RI/DRP
NAME	LDoerflein <i>STA</i>	DHolody <i>hw</i>	BLetts <i>hw</i>	CHeh <i>hw</i>
DATE	01/7/98	01/7/98	01/8/98	01/7/98

OFFICIAL RECORD COPY





UNITED STATES
NUCLEAR REGULATORY COMMISSION
REGION I
475 ALLENDALE ROAD
KING OF PRUSSIA, PENNSYLVANIA 19406-1415

January 8, 1998

IA 98-001

Mr. Albert M. Nardslico, Jr.
[HOME ADDRESS DELETED
UNDER 10 CFR 2.790]

SUBJECT: PREDECISIONAL ENFORCEMENT CONFERENCE
(NRC Investigation Report No. 1-96-015)

Dear Mr. Nardslico:

This is in reference to an investigation conducted by the NRC's Office of Investigations (OI) involving wrongdoing associated with the fitness-for-duty (FFD) testing computer program at the Nine Mile Point Nuclear Station. The purpose of the investigation was to determine who altered the Niagara Mohawk Power Corporation's (NMPC) FFD computer program, enabling certain individuals to be excluded from random drug testing. The investigation found that you and one other computer programmer intentionally altered the FFD computer program. A copy of the investigation synopsis is enclosed.

Based on our review of the investigation report, an apparent violation of the NRC's rule prohibiting deliberate misconduct, 10 CFR 50.5(a)(1), was identified. This rule prohibits licensee employees or contractors from engaging in deliberate misconduct that causes a licensee to be in violation of any rule or regulation. In this case, altering the FFD computer program to exclude certain individuals from random drug testing was a violation of 10 CFR 26.24 which requires that individuals be tested in a statistically and unpredictable manner.

On December 8, 1997, the conclusions of the investigation were discussed with you by Mr. Lawrence Doerflein of this office. During that discussion, you were asked if you wanted a predecisional enforcement conference prior to the NRC determining the appropriate enforcement action to take. You stated you wanted to discuss the matter with your lawyer before making that decision, and that you would get back to the NRC. On December 29, 1997, Mr. Doerflein left a message on your work voice mail inquiring about your decision. As of the date of this letter, the NRC has not been informed of your decision.

Therefore, the purpose of this letter is to inform you that, unless you inform the NRC within seven days after receipt of this letter that you want a predecisional enforcement conference to discuss the apparent violation noted above, the NRC will proceed with enforcement action. You can inform Mr. Doerflein at 610-337-5378 of your decision.

CERTIFIED MAIL
RETURN RECEIPT REQUESTED



For your information, if you decide you want a conference, it would be predecisional because the NRC has not made a final determination that violations of NRC requirements occurred or that enforcement action will be taken against you. The purpose of the conference, which would be transcribed, would be to discuss the apparent violation and the circumstances surrounding it, and to give you an opportunity to provide your perspective on this issue and any other information that you believe is relevant to the NRC's enforcement determination. You are specifically invited to address the factors that the NRC would consider in determining whether enforcement action should be taken against you. These factors are described in Section VIII, Enforcement Actions Involving Individuals, of the enclosed copy of the "General Statement of Policy and Procedures for NRC Enforcement Actions," NUREG-1600.

If the NRC concludes that you deliberately caused or committed a violation of NRC requirements, the possible sanctions include a Notice of Violation, a civil penalty,¹ or an order. An order may prohibit involvement in NRC-licensed activities, require notice to the NRC before resuming involvement in NRC-licensed activities, or require other action. Accordingly, if you decide you want a predecisional enforcement conference, you should be prepared to address why NRC should not issue you an Order removing you from licensed activities.

Although not required, you may provide the NRC a written reply to the apparent violation prior to or during the conference. In addition, you may have an attorney or personal representative attend the conference but it should be understood that the NRC will address its questions to you.

You will be advised by separate correspondence of the results of our deliberations on this matter. No response regarding the apparent violation is required at this time. Should you have any questions about this letter or the conference, please contact Mr. Doerflein.

¹ Civil penalties are not normally imposed on unlicensed individuals. See Footnote 10 of the NRC Enforcement Policy.



Albert M. Nardslico, Jr.

3

In accordance with 10 CFR 2.790 of the NRC's "Rules of Practice," a copy of this letter, with your home address removed, and Enclosure 1 will be placed in the NRC Public Document Room. However, the NRC will delay placing a copy of this letter and Enclosure 1 in the NRC Public Document Room (PDR) until an enforcement decision has been made. At that time, in accordance with 10 CFR 2.790 of the NRC's "Rules of Practice," a copy of this letter, with your home address removed, and Enclosure 1 will be placed in the PDR.

Sincerely,

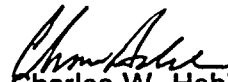

Charles W. Hehl, Director
Division of Reactor Projects

Docket Nos. 50-220, 50-410
License Nos. DPR-63, NPF-69

Enclosures:

1. Synopsis, OI 1-96-015
2. NRC Enforcement Policy
3. 10 CFR 50.5(a)(1)
4. 10 CFR 26.24

cc w/encls:

Mr. B. Ralph Sylvia, Executive Vice President and Chief Nuclear Officer



Albert M. Nardslico, Jr.

4

Distribution w/encs:

Region I Docket Room (w/concurrences)

H. Miller, RA/W. Axelson, DRA (1)

D. Screnci, PAO

Region I Docket Room (with concurrences)

Nuclear Safety Information Center (NSIC)

NRC Resident Inspector

L. Doerflein, DRP

R. Junod, DRP

Distribution w/encs: (VIA E-MAIL)

M. Leach, RI EDO Coordinator

R. Zimmerman, ADPR, NRR

F. Davis, NRR

A. Nicosia, NRR

J. Lieberman, OE (OE MAIL)

T. Reis, OE

D. Holody, OE, RI

T. Walker, SES, RI

B. Norris - Nine Mile Point

S. Bajwa, NRR

D. Hood, NRR

M. Campion, RI

Inspection Program Branch (IPAS)



SYNOPSIS

On May 13, 1996, an investigation was initiated by the NRC's Office of Investigations, Region I, to determine who altered the Niagara Mohawk Power Corporation's (NMPC) Fitness for Duty (FFD) computer program, enabling certain individuals to be excluded from the NMPC's random drug testing at the Nine Mile Point Nuclear Station, Lycoming, NY.

Based on the evidence developed during the investigation and review of evidence in the licensee's investigative report, it is concluded that two computer programmers intentionally altered the NMPC FFD computer program to ensure that certain individuals would be excluded from random FFD screening.

~~NOT FOR PUBLIC DISCLOSURE WITHOUT APPROVAL OF
FIELD OFFICE DIRECTOR, OFFICE OF INVESTIGATIONS, REGION I~~



U.S. NUCLEAR REGULATORY COMMISSION

Enforcement Policy Statement

This document compiles the "General Statement of Policy and Procedures for NRC Enforcement Actions," (Enforcement Policy), NUREG-1600, published June 30, 1995, and the various amendments to the Enforcement Policy approved by the Commission through September 10, 1997. It is the staff's intent to republish NUREG-1600 later this year. Pending that republication, the Office of Enforcement is issuing this interim compilation of all amendments to the Policy since it was last published. This document is also accessible on the Internet at: www.nrc.gov/OE.

The amendments to the Policy were published in the Federal Register as follows:

<u>Subject:</u>	<u>Federal Register</u>	<u>Date</u>
Adjustment of Civil Monetary Penalties	61FR53553	10/11/96
Departures from FSAR	61FR54461	10/18/96
Commission consultation, Open Enforcement Conferences; risk; NCVs	61FR65088	12/10/96
Part 20, Exceedance of dose constraints	61FR65128	12/10/96
Correction as to exercise of discretion	61FR68070	12/26/96
Gaseous Diffusion Plants; NRC organizational changes; Commission consultation	62FR06677	02/12/97
Participation in enforcement conferences involving discrimination	62FR13906	03/24/97
Part 34, Radiography, examples of potential violations	62FR28974	05/28/97
Corrections to Part 34 examples	62FR33447	06/19/97
Enforcement conference clarification	62FR52577	10/08/97

The Enforcement Policy is a general statement of policy explaining the NRC's policies and procedures in initiating enforcement actions, and of the presiding officers and the Commission in reviewing these actions. This policy statement is applicable to enforcement in matters involving the radiological health and safety of the public, including employees' health and safety, the common defense and security, and the environment. This statement of general policy and procedures is published to provide widespread dissemination of the Commission's Enforcement Policy. However, this is a policy statement and not a regulation. The Commission may deviate from this statement of policy and procedure as appropriate under the circumstances of a particular case.

Questions concerning the Enforcement Policy should be directed to the NRC's Office of Enforcement at (301) 415-2741.

James Lieberman, Director
Office of Enforcement

Compilation of NRC Enforcement Policy as of September 10, 1997

GENERAL STATEMENT OF POLICY AND PROCEDURE FOR NRC ENFORCEMENT ACTIONS

Table of Contents

Preface

I. INTRODUCTION AND PURPOSE

II. STATUTORY AUTHORITY

- A. Statutory Authority
- B. Procedural Framework

III. RESPONSIBILITIES

IV. SEVERITY OF VIOLATIONS

- A. Aggregation of Violations
- B. Repetitive Violations
- C. Willful Violations
- D. Violations of Reporting Requirements

V. PREDECISIONAL ENFORCEMENT CONFERENCES

VI. ENFORCEMENT ACTIONS

- A. Notice of Violation
- B. Civil Penalty
 - 1. Base Civil Penalty
 - 2. Civil Penalty Assessment
- a. Initial Escalated Action
- b. Credit for Actions Related to Identification
- c. Credit for Prompt and Comprehensive Corrective Action
- d. Exercise of Discretion
- C. Orders
- D. Related Administrative Actions

VII. EXERCISE OF DISCRETION

- A. Escalation of Enforcement Sanctions
 - 1. Civil Penalties
 - 2. Orders
 - 3. Daily Civil Penalties
- B. Mitigation of Enforcement Sanctions
 - 1. Licensee-Identified Severity Level IV Violations
 - 2. Violations Identified During Extended Shutdowns or Work Stoppages
 - 3. Violations Involving Old Design Issues
 - 4. Violations Identified Due to Previous Escalated Enforcement Action
 - 5. Violations Involving Discrimination
 - 6. Violations Involving Special Circumstances
- C. Exercise of Discretion for an Operating Facility

VIII. ENFORCEMENT ACTIONS INVOLVING INDIVIDUALS

IX. INACCURATE AND INCOMPLETE INFORMATION

X. ENFORCEMENT ACTION AGAINST NON-LICENSEES

XI. REFERRALS TO THE DEPARTMENT OF JUSTICE

XII. PUBLIC DISCLOSURE OF ENFORCEMENT ACTIONS

XIII. REOPENING CLOSED ENFORCEMENT ACTIONS SUPPLEMENTS

PREFACE

The following statement of general policy and procedure explains the enforcement policy and procedures of the U.S. Nuclear Regulatory Commission (NRC or Commission) and the NRC staff (staff) in initiating enforcement actions, and of the presiding officers and the Commission in reviewing these actions. This statement is applicable to enforcement in matters involving the radiological health and safety of the public, including employees' health and safety, the common defense and security, and the environment.¹ This statement of general policy and procedure will be published as NUREG-1600 to provide widespread dissemination of the Commission's Enforcement Policy. However, this is a policy statement and not a regulation. The Commission may deviate from this statement of policy and procedure as appropriate under the circumstances of a particular case.

I. INTRODUCTION AND PURPOSE

The purpose of the NRC enforcement program is to support the NRC's overall safety mission in protecting the public and the environment. Consistent with that purpose, enforcement action should be used:

- As a deterrent to emphasize the importance of compliance with requirements, and
- To encourage prompt identification and prompt, comprehensive correction of violations.

¹ Antitrust enforcement matters will be dealt with on a case-by-case basis.

Consistent with the purpose of this program, prompt and vigorous enforcement action will be taken when dealing with licensees, vendors², contractors, and their employees, who do not achieve the necessary meticulous attention to detail and the high standard of compliance which the NRC expects.³ Each enforcement action is dependent on the circumstances of the case and requires the exercise of discretion after consideration of this enforcement policy. In no case, however, will licensees who cannot achieve and maintain adequate levels of protection be permitted to conduct licensed activities.

II. STATUTORY AUTHORITY AND PROCEDURAL FRAMEWORK

A. Statutory Authority

The NRC's enforcement jurisdiction is drawn from the Atomic Energy Act of 1954, as amended, and the Energy Reorganization Act (ERA) of 1974, as amended.

² The term "vendor" as used in this policy means a supplier of products or services to be used in an NRC-licensed facility or activity.

³ This policy primarily addresses the activities of NRC licensees and applicants for NRC licenses. Therefore, the term "licensee" is used throughout the policy. However, in those cases where the NRC determines that it is appropriate to take enforcement action against a non-licensee or individual, the guidance in this policy will be used, as applicable. Specific guidance regarding enforcement action against individuals and non-licensees is addressed in Sections VIII and X, respectively.

Section 161 of the Atomic Energy Act authorizes the NRC to conduct inspections and investigations and to issue orders as may be necessary or desirable to promote the common defense and security or to protect health or to minimize danger to life or property. Section 186 authorizes the NRC to revoke licenses under certain circumstances (e.g., for material false statements, in response to conditions that would have warranted refusal of a license on an original application, for a licensee's failure to build or operate a facility in accordance with the terms of the permit or license, and for violation of an NRC regulation). Section 234 authorizes the NRC to impose civil penalties not to exceed \$100,000 per violation per day for the violation of certain specified licensing provisions of the Act, rules, orders, and license terms implementing these provisions, and for violations for which licenses can be revoked. In addition to the enumerated provisions in section 234, sections 84 and 147 authorize the imposition of civil penalties for violations of regulations implementing those provisions. Section 232 authorizes the NRC to seek injunctive or other equitable relief for violation of regulatory requirements.

Section 206 of the Energy Reorganization Act authorizes the NRC to impose civil penalties for knowing and conscious failures to provide certain safety information to the NRC.

Norwithstanding the \$100,000 limit stated in the Atomic Energy Act, the Commission may impose higher civil penalties as provided by the Debt Collection Improvement Act of 1996. Under the Act, the Commission is required to modify civil monetary penalties to reflect inflation. The adjusted maximum civil penalty amount is reflected in 10 CFR 2.205 and this Policy Statement.

Chapter 18 of the Atomic Energy Act provides for varying levels of criminal penalties (i.e., monetary fines and imprisonment) for willful violations of

the Act and regulations or orders issued under sections 65, 161(b), 161(i), or 161(o) of the Act. Section 223 provides that criminal penalties may be imposed on certain individuals employed by firms constructing or supplying basic components of any utilization facility if the individual knowingly and willfully violates NRC requirements such that a basic component could be significantly impaired. Section 235 provides that criminal penalties may be imposed on persons who interfere with inspectors. Section 236 provides that criminal penalties may be imposed on persons who attempt to or cause sabotage at a nuclear facility or to nuclear fuel. Alleged or suspected criminal violations of the Atomic Energy Act are referred to the Department of Justice for appropriate action.

B. Procedural Framework

Subpart B of 10 CFR Part 2 of NRC's regulations sets forth the procedures the NRC uses in exercising its enforcement authority. 10 CFR 2.201 sets forth the procedures for issuing notices of violation.

The procedure to be used in assessing civil penalties is set forth in 10 CFR 2.205. This regulation provides that the civil penalty process is initiated by issuing a Notice of Violation and Proposed Imposition of a Civil Penalty. The licensee or other person is provided an opportunity to contest in writing the proposed imposition of a civil penalty. After evaluation of the response, the civil penalty may be mitigated, remitted, or imposed. An opportunity is provided for a hearing if a civil penalty is imposed. If a civil penalty is not paid following a hearing or if a hearing is not requested, the matter may be referred to the U.S. Department of Justice to institute a civil action in District Court.

The procedure for issuing an order to institute a proceeding to modify, suspend, or revoke a license or to take other action against a licensee or other person subject to the jurisdiction of the Commission is set forth in 10 CFR 2.202. The licensee or any other person adversely affected by the order

may request a hearing. The NRC is authorized to make orders immediately effective if required to protect the public health, safety, or interest, or if the violation is willful. Section 2.204 sets out the procedures for issuing a Demand for Information (Demand) to a licensee or other person subject to the Commission's jurisdiction for the purpose of determining whether an order or other enforcement action should be issued. The Demand does not provide hearing rights, as only information is being sought. A licensee must answer a Demand. An unlicensed person may answer a Demand by either providing the requested information or explaining why the Demand should not have been issued.

III. RESPONSIBILITIES

The Executive Director for Operations (EDO) and the principal enforcement officer of the NRC, the Deputy Executive Director for Regulatory Effectiveness, hereafter referred to as the Deputy Executive Director, has been delegated the authority to approve or issue all escalated enforcement actions.⁴ The Deputy Executive Director is responsible to the EDO for the NRC enforcement program. The Office of Enforcement (OE) exercises oversight of and implements the NRC enforcement program. The Director, OE, acts for the Deputy Executive Director in enforcement matters in his absence or as delegated.

Subject to the oversight and direction of OE, and with the approval of the Deputy Executive Director, where necessary, the regional offices normally issue Notices of Violation and

⁴ The term "escalated enforcement action" as used in this policy means a Notice of Violation or civil penalty for any Severity Level I, II, or III violation (or problem) or any order based upon a violation.

proposed civil penalties. However, subject to the same oversight as the regional offices, the Office of Nuclear Reactor Regulation (NRR) and the Office of Nuclear Material Safety and Safeguards (NMSS) may also issue Notices of Violation and proposed civil penalties for certain activities.

Enforcement orders are normally issued by the Deputy Executive Director or the Director, OE. However, orders may also be issued by the EDO, especially those involving the more significant matters. The Directors of NRR and NMSS have also been delegated authority to issue orders, but it is expected that normal use of this authority by NRR and NMSS will be confined to actions not associated with compliance issues. The Director, Office of the Controller, has been delegated the authority to issue orders where licensees violate Commission regulations by nonpayment of license and inspection fees.

In recognition that the regulation of nuclear activities in many cases does not lend itself to a mechanistic treatment, judgment and discretion must be exercised in determining the severity levels of the violations and the appropriate enforcement sanctions, including the decision to issue a Notice of Violation, or to propose or impose a civil penalty and the amount of this penalty, after considering the general principles of this statement of policy and the technical significance of the violations and the surrounding circumstances.

Unless Commission consultation or notification is required by this policy, the NRC staff may depart, where warranted in the public's interest, from this policy as provided in Section VII, "Exercise of Enforcement Discretion." The Commission will be provided written notification of all enforcement actions involving civil penalties or orders. The Commission will also be provided notice the first time that discretion is exercised for a plant

meeting the criteria of Section VII.B.2. In addition, the Commission will be consulted prior to taking action in the following situations (unless the urgency of the situation dictates immediate action):

- (1) An action affecting a licensee's operation that requires balancing the public health and safety or common defense and security implications of not operating with the potential radiological or other hazards associated with continued operation;
- (2) Proposals to impose a civil penalty for a single violation or problem that is greater than 3 times the Severity Level I value shown in Table 1A for that class of licensee;
- (3) Any proposed enforcement action that involves a Severity Level I violation;
- (4) Any action the EDO believes warrants Commission involvement;
- (5) Any proposed enforcement case involving an Office of Investigations (OI) report where the NRC staff (other than the OI staff) does not arrive at the same conclusions as those in the OI report concerning issues of intent if the Director of OI concludes that Commission consultation is warranted; and
- (6) Any proposed enforcement action on which the Commission asks to be consulted.

IV. SEVERITY OF VIOLATIONS

Regulatory requirements⁵ have varying degrees of safety, safeguards, or environmental significance. Therefore, the relative importance of each violation, including both the technical significance and the regulatory significance, is evaluated as the first step in the enforcement process. In

⁵ The term "requirement" as used in this policy means a legally binding requirement such as a statute, regulation, license condition, technical specification, or order.

considering the significance of a violation, the staff considers the technical significance, i.e., actual and potential consequences, and the regulatory significance. In evaluating the technical significance, risk is an appropriate consideration.

Consequently, for purposes of formal enforcement action, violations are normally categorized in terms of four levels of severity to show their relative importance within each of the following eight activity areas:

- I. Reactor Operations;
- II. Facility Construction;
- III. Safeguards;
- IV. Health Physics;
- V. Transportation;
- VI. Fuel Cycle and Materials Operations;
- VII. Miscellaneous Matters; and
- VIII. Emergency Preparedness.

Licensed activities will be placed in the activity area most suitable in light of the particular violation involved including activities not directly covered by one of the above listed areas, e.g., export license activities. Within each activity area, Severity Level I has been assigned to violations that are the most significant and Severity Level IV violations are the least significant. Severity Level I and II violations are of very significant regulatory concern. In general, violations that are included in these severity categories involve actual or high potential impact on the public. Severity Level III violations are cause for significant regulatory concern. Severity Level IV violations are less serious but are of more than minor concern; i.e., if left uncorrected, they could lead to a more serious concern.

The Commission recognizes that there are other violations of minor safety or environmental concern which are below the level of significance of Severity Level IV violations. These minor violations are not the subject of formal enforcement action and are not usually

described in inspection reports. To the extent such violations are described, they are noted as Non-Cited Violations.⁶

Comparisons of significance between activity areas are inappropriate. For example, the immediacy of any hazard to the public associated with Severity Level I violations in Reactor Operations is not directly comparable to that associated with Severity Level I violations in Facility Construction.

Supplements I through VIII provide examples and serve as guidance in determining the appropriate severity level for violations in each of the eight activity areas. However, the examples are neither exhaustive nor controlling. In addition, these examples do not create new requirements. Each is designed to illustrate the significance that the NRC places on a particular type of violation of NRC requirements. Each of the examples in the supplements is predicated on a violation of a regulatory requirement.

The NRC reviews each case being considered for enforcement action on its own merits to ensure that the severity of a violation is characterized at the level best suited to the significance of the particular violation. In some cases, special circumstances may warrant an adjustment to the severity level categorization.

A. Aggregation of Violations

A group of Severity Level IV violations may be evaluated in the aggregate and assigned a single, increased severity level, thereby resulting in a Severity Level III problem, if the violations have the same underlying cause or programmatic deficiencies, or the violations contributed to or were unavoidable

⁶ A Non-Cited Violation (NCV) is a violation that has not been formalized into a 10 CFR 2.201 Notice of Violation.

consequences of the underlying problem. Normally, Severity Level II and III violations are not aggregated into a higher severity level.

The purpose of aggregating violations is to focus the licensee's attention on the fundamental underlying causes for which enforcement action appears warranted and to reflect the fact that several violations with a common cause may be more significant collectively than individually and may therefore, warrant a more substantial enforcement action.

B. Repetitive Violations

The severity level of a Severity Level IV violation may be increased to Severity Level III, if the violation can be considered a repetitive violation.⁷ The purpose of escalating the severity level of a repetitive violation is to acknowledge the added significance of the situation based on the licensee's failure to implement effective corrective action for the previous violation. The decision to escalate the severity level of a repetitive violation will depend on the circumstances, such as, but not limited to, the number of times the violation has occurred, the similarity of the violations and their root causes, the adequacy of previous corrective actions, the period of time between the violations, and the significance of the violations.

C. Willful Violations

Willful violations are by definition of particular concern to the Commission because its regulatory program is based on licensees and their contractors, employees,

⁷ The term "repetitive violation" or "similar violation" as used in this policy statement means a violation that reasonably could have been prevented by a licensee's corrective action for a previous violation normally occurring (1) within the past 2 years of the inspection at issue, or (2) the period within the last two inspections, whichever is longer.

and agents acting with integrity and communicating with candor. Willful violations cannot be tolerated by either the Commission or a licensee. Licensees are expected to take significant remedial action in responding to willful violations commensurate with the circumstances such that it demonstrates the seriousness of the violation thereby creating a deterrent effect within the licensee's organization. Although removal of the person is not necessarily required, substantial disciplinary action is expected.

Therefore, the severity level of a violation may be increased if the circumstances surrounding the matter involve careless disregard of requirements, deception, or other indications of willfulness. The term "willfulness" as used in this policy embraces a spectrum of violations ranging from deliberate intent to violate or falsify to and including careless disregard for requirements. Willfulness does not include acts which do not rise to the level of careless disregard, e.g., inadvertent clerical errors in a document submitted to the NRC. In determining the specific severity level of a violation involving willfulness, consideration will be given to such factors as the position and responsibilities of the person involved in the violation (e.g., licensee official⁸

⁸ The term "licensee official" as used in this policy statement means a first-line supervisor or above, a licensed individual, a radiation safety officer, or an authorized user of licensed material whether or not listed on a license. Notwithstanding an individual's job title, severity level categorization for willful acts involving individuals who can be considered licensee officials will consider several factors, including the position of the individual relative to the licensee's organizational structure and the

or non-supervisory employee), the significance of any underlying violation, the intent of the violator (i.e., careless disregard or deliberateness), and the economic or other advantage, if any, gained as a result of the violation. The relative weight given to each of these factors in arriving at the appropriate severity level will be dependent on the circumstances of the violation. However, if a licensee refuses to correct a minor violation within a reasonable time such that it willfully continues, the violation should be categorized at least at a Severity Level IV.

D. Violations of Reporting Requirements

The NRC expects licensees to provide complete, accurate, and timely information and reports. Accordingly, unless otherwise categorized in the Supplements, the severity level of a violation involving the failure to make a required report to the NRC will be based upon the significance of and the circumstances surrounding the matter that should have been reported. However, the severity level of an untimely report, in contrast to no report, may be reduced depending on the circumstances surrounding the matter. A licensee will not normally be cited for a failure to report a condition or event unless the licensee was actually aware of the condition or event that it failed to report. A licensee will, on the other hand, normally be cited for a failure to report a condition or event if the licensee knew of the information to be reported, but did not recognize that it was required to make a report.

V. PREDECISIONAL ENFORCEMENT CONFERENCES

Whenever the NRC has learned of the

individual's responsibilities relative to the oversight of licensed activities and to the use of licensed material.

existence of a potential violation for which escalated enforcement action appears to be warranted, or recurring nonconformance on the part of a vendor, the NRC may provide an opportunity for a predecisional enforcement conference with the licensee, vendor, or other person before taking enforcement action. The purpose of the conference is to obtain information that will assist the NRC in determining the appropriate enforcement action, such as: (1) a common understanding of facts, root causes and missed opportunities associated with the apparent violations, (2) a common understanding of corrective actions taken or planned, and (3) a common understanding of the significance of issues and the need for lasting comprehensive corrective action.

If the NRC concludes that it has sufficient information to make an informed enforcement decision, a conference will not normally be held unless the licensee requests it. However, an opportunity for a conference will normally be provided before issuing an order based on a violation of the rule on Deliberate Misconduct or a civil penalty to an unlicensed person. If a conference is not held, the licensee will normally be requested to provide a written response to an inspection report, if issued, as to the licensee's views on the apparent violations and their root causes and a description of planned or implemented corrective actions.

During the predecisional enforcement conference, the licensee, vendor, or other persons will be given an opportunity to provide information consistent with the purpose of the conference, including an explanation to the NRC of the immediate corrective actions (if any) that were taken following identification of the potential violation or nonconformance and the long-term comprehensive actions that were taken or will be taken to prevent recurrence. Licensees, vendors, or other persons will be told when a meeting is a predecisional enforcement conference.

A predecisional enforcement conference is a meeting between the NRC and the licensee. Conferences are normally held in the regional offices and are normally open

to public observation. Conferences will not normally be open to the public if the enforcement action being contemplated:

(1) Would be taken against an individual, or if the action, though not taken against an individual, turns on whether an individual has committed wrongdoing;

(2) Involves significant personnel failures where the NRC has requested that the individual(s) involved be present at the conference;

(3) Is based on the findings of an NRC Office of Investigations report that has not been publicly disclosed; or

(4) Involves safeguards information, Privacy Act information, or information which could be considered proprietary;

In addition, conferences will not normally be open to the public if:

(5) The conference involves medical misadministrations or overexposures and the conference cannot be conducted without disclosing the exposed individual's name; or

(6) The conference will be conducted by telephone or the conference will be conducted at a relatively small licensee's facility.

Notwithstanding meeting any of these criteria, a conference may still be open if the conference involves issues related to an ongoing adjudicatory proceeding with one or more intervenors or where the evidentiary basis for the conference is a matter of public record, such as an adjudicatory decision by the Department of Labor. In addition, notwithstanding the above normal criteria for opening or closing conferences, with the approval of the Executive Director for Operations, conferences may either be open or closed to the public after balancing the benefit of the public's observation against the potential impact on the agency's decision-making process in a particular case.

The NRC will notify the licensee that the conference will be open to public

observation. Consistent with the agency's policy on open meetings, "Staff Meetings Open to Public," published September 20, 1994 (59 FR 48340), the NRC intends to announce open conferences normally at least 10 working days in advance of conferences through (1) notices posted in the Public Document Room, (2) a toll-free telephone recording at 800-952-9674, (3) a toll-free electronic bulletin board at 800-952-9676, and on the World Wide Web at the NRC Office of Enforcement homepage (www.nrc.gov/OE). In addition, the NRC will also issue a press release and notify appropriate State liaison officers that a predecisional enforcement conference has been scheduled and that it is open to public observation.

The public attending open conferences may observe but may not participate in the conference. It is noted that the purpose of conducting open conferences is not to maximize public attendance, but rather to provide the public with opportunities to be informed of NRC activities consistent with the NRC's ability to exercise its regulatory and safety responsibilities. Therefore, members of the public will be allowed access to the NRC regional offices to attend open enforcement conferences in accordance with the "Standard Operating Procedures for Providing Security Support For NRC Hearings and Meetings," published November 1, 1991 (56 FR 56251). These procedures provide that visitors may be subject to personnel screening, that signs, banners, posters, etc., not larger than 18" be permitted, and that disruptive persons may be removed. The open conference will be terminated if disruption interferes with a successful conference. NRC's Predecisional Enforcement Conferences (whether open or closed) normally will be held at the NRC's regional offices or in NRC Headquarters Offices and not in the vicinity of the licensee's facility.

For a case in which an NRC Office of

Investigations (OI) report finds that discrimination as defined under 10 CFR 50.7 (or similar provisions in Parts 30, 40, 60, 70, or 72) has occurred, the OI report may be made public, subject to withholding certain information (i.e., after appropriate redaction), in which case the associated predecisional enforcement conference will normally be open to public observation. In a conference where a particular individual is being considered potentially responsible for the discrimination, the conference will remain closed. In either case (i.e., whether the conference is open or closed), the employee or former employee who was the subject of the alleged discrimination (hereafter referred to as "complainant") will normally be provided an opportunity to participate in the predecisional enforcement conference with the licensee/employer. This participation will normally be in the form of a complainant statement and comment on the licensee's presentation, followed in turn by an opportunity for the licensee to respond to the complainant's presentation. In cases where the complainant is unable to attend in person, arrangements will be made for the complainant's participation by telephone or an opportunity given for the complainant to submit a written response to the licensee's presentation. If the licensee chooses to forego an enforcement conference and, instead, responds to the NRC's findings in writing, the complainant will be provided the opportunity to submit written comments on the licensee's response. For cases involving potential discrimination by a contractor or vendor to the licensee, any associated predecisional enforcement conference with the contractor or vendor would be handled similarly. These arrangements for complainant participation in the predecisional enforcement conference are not to be conducted or viewed in any respect as an adjudicatory hearing. The purpose of the complainant's participation is to provide information to the NRC to assist it in its enforcement deliberations.

A predecisional enforcement conference may not need to be held in cases where there is a full adjudicatory record before the

Department of Labor. If a conference is held in such cases, generally the conference will focus on the licensee's corrective action. As with discrimination cases based on OI investigations, the complainant may be allowed to participate.

Members of the public attending open conferences will be reminded that (1) the apparent violations discussed at predecisional enforcement conferences are subject to further review and may be subject to change prior to any resulting enforcement action and (2) the statements of views or expressions of opinion made by NRC employees at predecisional enforcement conferences, or the lack thereof, are not intended to represent final determinations or beliefs.

When needed to protect the public health and safety or common defense and security, escalated enforcement action, such as the issuance of an immediately effective order, will be taken before the conference. In these cases, a conference may be held after the escalated enforcement action is taken.

VI. ENFORCEMENT ACTIONS

This section describes the enforcement sanctions available to the NRC and specifies the conditions under which each may be used. The basic enforcement sanctions are Notices of Violation, civil penalties, and orders of various types. As discussed further in Section VI.D, related administrative actions such as Notices of Nonconformance, Notices of Deviation, Confirmatory Action Letters, Letters of Reprimand, and Demands for Information are used to supplement the enforcement program. In selecting the enforcement sanctions or administrative actions, the NRC will consider enforcement actions taken by other Federal or State regulatory bodies having concurrent jurisdiction, such as in transportation matters. Usually, whenever a violation of NRC

requirements of more than a minor concern is identified, enforcement action is taken. The nature and extent of the enforcement action is intended to reflect the seriousness of the violation involved. For the vast majority of violations, a Notice of Violation or a Notice of Nonconformance is the normal action.

A. Notice of Violation

A Notice of Violation is a written notice setting forth one or more violations of a legally binding requirement. The Notice of Violation normally requires the recipient to provide a written statement describing (1) the reasons for the violation or, if contested, the basis for disputing the violation; (2) corrective steps that have been taken and the results achieved; (3) corrective steps that will be taken to prevent recurrence; and (4) the date when full compliance will be achieved. The NRC may waive all or portions of a written response to the extent relevant information has already been provided to the NRC in writing or documented in an NRC inspection report. The NRC may require responses to Notices of Violation to be under oath. Normally, responses under oath will be required only in connection with Severity Level I, II, or III violations or orders.

The NRC uses the Notice of Violation as the usual method for formalizing the existence of a violation. Issuance of a Notice of Violation is normally the only enforcement action taken, except in cases where the criteria for issuance of civil penalties and orders, as set forth in Sections VI.B and VI.C, respectively, are met. However, special circumstances regarding the violation findings may warrant discretion being exercised such that the NRC refrains from issuing a Notice of Violation. (See Section VII.B, "Mitigation of Enforcement Sanctions.") In addition, licensees are not ordinarily cited for violations resulting from matters not within their control, such as equipment

failures that were not avoidable by reasonable licensee quality assurance measures or management controls. Generally, however, licensees are held responsible for the acts of their employees. Accordingly, this policy should not be construed to excuse personnel errors.

B. Civil Penalty

A civil penalty is a monetary penalty that may be imposed for violation of (1) certain specified licensing provisions of the Atomic Energy Act or supplementary NRC rules or orders; (2) any requirement for which a license may be revoked; or (3) reporting requirements under section 206 of the Energy Reorganization Act. Civil penalties are designed to deter future violations both by the involved licensee as well as by other licensees conducting similar activities and to emphasize the need for licensees to identify violations and take prompt comprehensive corrective action.

Civil penalties are considered for Severity Level III violations. In addition, civil penalties will normally be assessed for Severity Level I and II violations and knowing and conscious violations of the reporting requirements of section 206 of the Energy Reorganization Act.

Civil penalties are used to encourage prompt identification and prompt and comprehensive correction of violations, to emphasize compliance in a manner that deters future violations, and to serve to focus licensees' attention on violations of significant regulatory concern.

Although management involvement, direct or indirect, in a violation may lead to an increase in the civil penalty, the lack of management involvement may not be used to mitigate a civil penalty. Allowing mitigation in the latter case could encourage the lack of management involvement in licensed activities and a decrease in protection of the public health and safety.

1. Base Civil Penalty

The NRC imposes different levels of penalties for different severity level violations and different classes of licensees, vendors, and other persons. Tables 1A and 1B show the base civil penalties for various reactor, fuel cycle, materials, and vendor programs. (Civil penalties issued to individuals are determined on a case-by-case basis.) The structure of these tables generally takes into account the gravity of the violation as a primary consideration and the ability to pay as a secondary consideration. Generally, operations involving greater nuclear material inventories and greater potential consequences to the public and licensee employees receive higher civil penalties. Regarding the secondary factor of ability of various classes of licensees to pay the civil penalties, it is not the NRC's intention that the economic impact of a civil penalty be so severe that it puts a licensee out of business (orders, rather than civil penalties, are used when the intent is to suspend or terminate licensed activities) or adversely affects a licensee's ability to safely conduct licensed activities. The deterrent effect of civil penalties is best served when the amounts of the penalties take into account a licensee's ability to pay. In determining the amount of civil penalties for licensees for whom the tables do not reflect the ability to pay or the gravity of the violation, the NRC will consider as necessary an increase or decrease on a case-by-case basis. Normally, if a licensee can demonstrate financial hardship, the NRC will consider payments over time, including interest, rather than reducing the amount of the civil penalty. However, where a licensee claims financial hardship, the licensee will normally be required to address why it has sufficient resources to safely conduct licensed activities and pay license and inspection fees.

2. Civil Penalty Assessment

In an effort to (1) emphasize the importance of adherence to requirements and (2) reinforce prompt self-identification of problems and root causes and prompt and comprehensive correction of violations, the NRC reviews each proposed civil penalty on its own merits and, after considering all relevant circumstances, may adjust the base civil penalties shown in Table 1A and 1B for Severity Level I, II, and III violations as described below.

The civil penalty assessment process considers four decisional points: (a) whether the licensee has had any Previous escalated enforcement action (regardless of the activity area) during the past 2 years or past 2 inspections, whichever is longer; (b) whether the licensee should be given credit for actions related to identification; (c) whether the licensee's corrective actions are prompt and comprehensive; and (d) whether, in view of all the circumstances, the matter in question requires the exercise of discretion. Although each of these decisional points may have several

associated considerations for any given case, the outcome of the assessment process for each violation or problem, absent the exercise of discretion, is limited to one of the following three results: no civil penalty, a base civil penalty, or a base civil penalty escalated by 100%. The flow chart presented below is a graphic representation of the civil penalty assessment process.

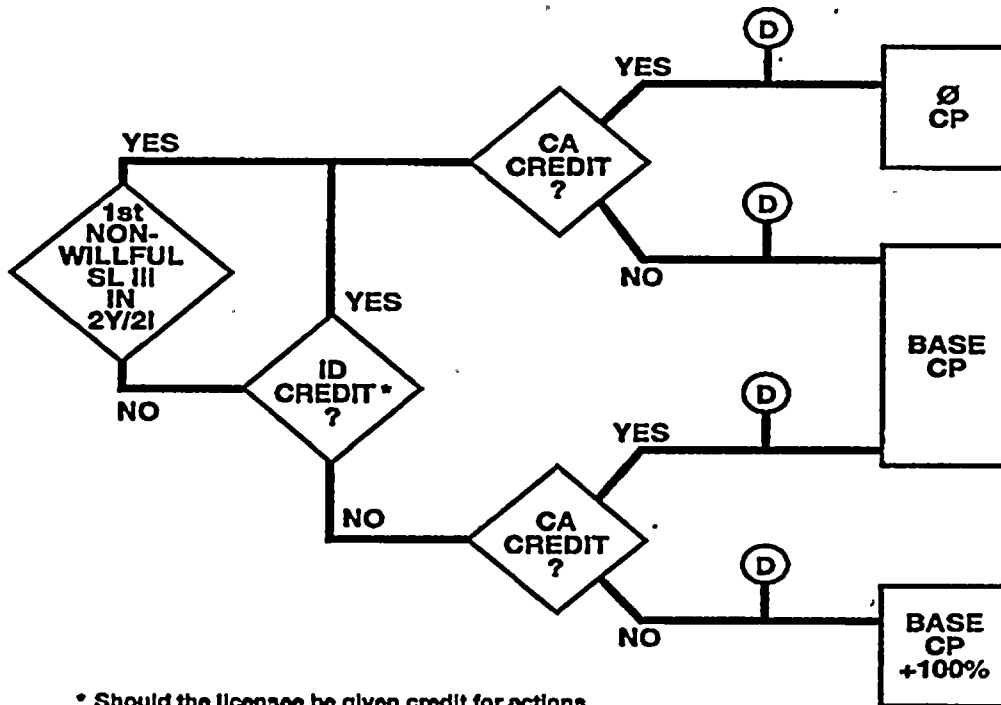

* Should the licensee be given credit for actions related to identification?

(D) Discretion, e.g., SL I and II violations should normally result in a civil penalty regardless of ID and CA.

a. Initial Escalated Action.

When the NRC determines that a non-willful Severity Level III violation or problem has occurred, and the licensee has not had any previous escalated actions (regardless of the activity area) during the past 2 years or 2 inspections, whichever is longer, the NRC will consider whether the licensee's corrective action for the present violation or problem is reasonably prompt and comprehensive (see the discussion under Section VI.B.2.c, below). Using 2 years as the basis for assessment is expected to cover most situations, but considering a slightly longer or shorter period might be warranted based on the circumstances of a particular case. The starting point of this period should be considered the date when the licensee was put on notice of the need to take corrective action. For a licensee-identified violation or an event, this would be when the licensee is aware that a problem or violation exists requiring corrective action. For an NRC-identified violation, the starting point would be when the NRC puts the licensee on notice, which could be during the inspection, at the inspection exit meeting, or as part of post-inspection communication.

If the corrective action is judged to be prompt and comprehensive, a Notice of Violation normally should be issued with no associated civil penalty. If the corrective action is judged to be less than prompt and comprehensive, the Notice of Violation normally should be issued with a base civil penalty.

b. Credit for Actions Related to Identification.

(1) If a Severity Level I or II violation or a willful Severity Level III violation has occurred--or if, during the past 2 years or 2 inspections, whichever is longer, the licensee has been issued at least one other escalated action--the civil penalty assessment should normally

consider the factor of identification in addition to corrective action (see the discussion under Section VI.B.2.c, below). As to identification, the NRC should consider whether the licensee should be given credit for actions related to identification.

In each case, the decision should be focused on identification of the problem requiring corrective action. In other words, although giving credit for *Identification* and *Corrective Action* should be separate decisions, the concept of *Identification* presumes that the identifier recognizes the existence of a problem, and understands that corrective action is needed. The decision on *Identification* requires considering all the circumstances of identification including:

- (i) Whether the problem requiring corrective action was NRC-identified, licensee-identified, or revealed through an event⁹;
- (ii) Whether prior opportunities existed to identify the problem requiring corrective action, and if so, the age and number of

⁹ An "event," as used here, means (1) an event characterized by an active adverse impact on equipment or personnel, readily obvious by human observation or instrumentation, or (2) a radiological impact on personnel or the environment in excess of regulatory limits, such as an overexposure, a release of radioactive material above NRC limits, or a loss of radioactive material. For example, an equipment failure discovered through a spill of liquid, a loud noise, the failure to have a system respond properly, or an annunciator alarm would be considered an event; a system discovered to be inoperable through a document review would not. Similarly, if a licensee discovered, through quarterly dosimetry readings, that employees had been inadequately monitored for radiation, the issue would normally be considered licensee-identified; however, if the same dosimetry readings disclosed an overexposure, the issue would be considered an event.

those opportunities;

(iii) Whether the problem was revealed as the result of a licensee self-monitoring effort, such as conducting an audit, a test, a surveillance, a design review, or troubleshooting;

(iv) For a problem revealed through an event, the ease of discovery, and the degree of licensee initiative in identifying the root cause of the problem and any associated violations;

(v) For NRC-identified issues, whether the licensee would likely have identified the issue in the same time-period if the NRC had not been involved;

(vi) For NRC-identified issues, whether the licensee should have identified the issue (and taken action) earlier; and

(vii) For cases in which the NRC identifies the overall problem requiring corrective action (e.g., a programmatic issue), the degree of licensee initiative or lack of initiative in identifying the problem or problems requiring corrective action.

(2) Although some cases may consider all of the above factors, the importance of each factor will vary based on the type of case as discussed in the following general guidance:

(i) Licensee-Identified. When a problem requiring corrective action is licensee-identified (i.e., identified before the problem has resulted in an event), the NRC should normally give the licensee credit for actions related to identification, regardless of whether prior opportunities existed to identify the problem.

(ii) Identified Through an Event. When a problem requiring corrective action is identified through an event, the decision on whether to give the licensee credit for actions related to identification normally should consider the ease of discovery, whether the event occurred as the result of a licensee self-monitoring effort (i.e., whether the licensee was "looking for the problem"), the degree of licensee

initiative in identifying the problem or problems requiring corrective action, and whether prior opportunities existed to identify the problem.

Any of these considerations may be overriding if particularly noteworthy or particularly egregious. For example, if the event occurred as the result of conducting a surveillance or similar self-monitoring effort (i.e., the licensee was looking for the problem), the licensee should normally be given credit for identification. As a second instance, even if the problem was easily discovered (e.g., revealed by a large spill of liquid), the NRC may choose to give credit because noteworthy licensee effort was exerted in ferreting out the root cause and associated violations, or simply because no prior opportunities (e.g., procedural cautions, post-maintenance testing, quality control failures, readily observable parameter trends, or repeated or locked-in annunciator warnings) existed to identify the problem.

(iii) NRC-Identified. When a problem requiring corrective action is NRC-identified, the decision on whether to give the licensee credit for actions related to *Identification* should normally be based on an additional question: should the licensee have reasonably identified the problem (and taken action) earlier?

In most cases, this reasoning may be based simply on the ease of the NRC inspector's discovery (e.g., conducting a walkdown, observing in the control room, performing a confirmatory NRC radiation survey, hearing a cavitating pump, or finding a valve obviously out of position). In some cases, the licensee's missed opportunities to identify the problem might include a similar previous violation, NRC or industry notices, internal audits, or readily observable trends.

If the NRC identifies the violation but concludes that, under the circumstances, the licensee's actions related to *Identification* were not unreasonable, the

matter would be treated as licensee-identified for purposes of assessing the civil penalty. In such cases, the question of *Identification* credit shifts to whether the licensee should be penalized for NRC's identification of the problem.

(iv) Mixed Identification. For "mixed" identification situations (i.e., where multiple violations exist, some NRC-identified, some licensee-identified, or where the NRC prompted the licensee to take action that resulted in the identification of the violation), the NRC's evaluation should normally determine whether the licensee could reasonably have been expected to identify the violation in the NRC's absence. This determination should consider, among other things, the timing of the NRC's discovery, the information available to the licensee that caused the NRC concern, the specificity of the NRC's concern, the scope of the licensee's efforts, the level of licensee resources given to the investigation, and whether the NRC's path of analysis had been dismissed or was being pursued in parallel by the licensee.

In some cases, the licensee may have addressed the isolated symptoms of each violation (and may have identified the violations), but failed to recognize the common root cause and taken the necessary comprehensive action. Where this is true, the decision on whether to give licensee credit for actions related to *Identification* should focus on identification of the *problem requiring corrective action* (e.g., the programmatic breakdown). As such, depending on the chronology of the various violations, the earliest of the individual violations might be considered missed opportunities for the licensee to have identified the larger problem.

(v) Missed Opportunities to Identify. Missed opportunities include prior notifications or missed opportunities to identify or prevent violations such as (1) through normal surveillances, audits, or quality assurance (QA) activities; (2) through prior notice i.e., specific NRC or industry notification; or (3) through other reasonable indication of a potential problem or violation, such as observations of

employees and contractors, and failure to take effective corrective steps. It may include findings of the NRC, the licensee, or industry made at other facilities operated by the licensee where it is reasonable to expect the licensee to take action to identify or prevent similar problems at the facility subject to the enforcement action at issue. In assessing this factor, consideration will be given to, among other things, the opportunities available to discover the violation, the ease of discovery, the similarity between the violation and the notification, the period of time between when the violation occurred and when the notification was issued, the action taken (or planned) by the licensee in response to the notification, and the level of management review that the notification received (or should have received).

The evaluation of missed opportunities should normally depend on whether the information available to the licensee should reasonably have caused action that would have prevented the violation. Missed opportunities is normally not applied where the licensee appropriately reviewed the opportunity for application to its activities and reasonable action was either taken or planned to be taken within a reasonable time.

In some situations the missed opportunity is a violation in itself. In these cases, unless the missed opportunity is a Severity Level III violation in itself, the missed opportunity violation may be grouped with the other violations into a single Severity Level III "problem." However, if the missed opportunity is the *only* violation, then it should not normally be counted twice (i.e., both as the violation and as a missed opportunity--"double counting") unless the number of opportunities missed was particularly significant.

The timing of the missed opportunity should also be considered. While a

rigid time-frame is unnecessary, a 2-year period should generally be considered for consistency in implementation, as the period reflecting relatively current performance.

(3) When the NRC determines that the licensee should receive credit for actions related to *Identification*, the civil penalty assessment should normally result in either no civil penalty or a base civil penalty, based on whether *Corrective Action* is judged to be reasonably prompt and comprehensive. When the licensee is *not* given credit for actions related to *Identification*, the civil penalty assessment should normally result in a Notice of Violation with either a base civil penalty or a base civil penalty escalated by 100%, depending on the quality of *Corrective Action*, because the licensee's performance is clearly not acceptable.

c. Credit for Prompt and Comprehensive Corrective Action.

The purpose of the *Corrective Action* factor is to encourage licensees to (1) take the immediate actions necessary upon discovery of a violation that will restore safety and compliance with the license, regulation(s), or other requirement(s); and (2) develop and implement (in a timely manner) the lasting actions that will not only prevent recurrence of the violation at issue, but will be appropriately comprehensive, given the significance and complexity of the violation, to prevent occurrence of violations with similar root causes.

Regardless of other circumstances (e.g., past enforcement history, identification), the licensee's corrective actions should always be evaluated as part of the civil penalty assessment process. As a reflection of the importance given to this factor, an NRC judgment that the licensee's corrective action has not been prompt and comprehensive will always result in issuing at least a base civil penalty.

In assessing this factor, consideration

will be given to the timeliness of the corrective action (including the promptness in developing the schedule for long term corrective action), the adequacy of the licensee's root cause analysis for the violation, and, given the significance and complexity of the issue, the comprehensiveness of the corrective action (i.e., whether the action is focused narrowly to the specific violation or broadly to the general area of concern). Even in cases when the NRC, at the time of the enforcement conference, identifies additional peripheral or minor corrective action still to be taken, the licensee may be given credit in this area, as long as the licensee's actions addressed the underlying root cause and are considered sufficient to prevent recurrence of the violation and similar violations.

Normally, the judgment of the adequacy of corrective actions will hinge on whether the NRC had to take action to focus the licensee's evaluative and corrective process in order to obtain comprehensive corrective action. This will normally be judged at the time of the enforcement conference (e.g., by outlining substantive additional areas where corrective action is needed). Earlier informal discussions between the licensee and NRC inspectors or management may result in improved corrective action, but should not normally be a basis to deny credit for *Corrective Action*. For cases in which the licensee does not get credit for actions related to *Identification* because the NRC identified the problem, the assessment of the licensee's corrective action should begin from the time when the NRC put the licensee on notice of the problem.

Notwithstanding eventual good comprehensive corrective action, if immediate corrective action was not taken to restore safety and compliance once the violation was identified, corrective action would not be considered prompt and comprehensive.

Corrective action for violations involving discrimination should normally only be considered comprehensive if the licensee takes prompt, comprehensive corrective action that (1) addresses the broader

environment for raising safety concerns in the workplace, and (2) provides a remedy for the particular discrimination at issue.

In response to violations of 10 CFR 50.59, corrective action should normally be considered prompt and comprehensive only if the licensee

- (i) Makes a prompt decision on operability; and either
- (ii) Makes a prompt evaluation under 10 CFR 50.59 if the licensee intends to maintain the facility or procedure in the as found condition; or
- (iii) Promptly initiates corrective action consistent with Criterion XVI of 10 CFR 50, Appendix B, if it intends to restore the facility or procedure to the FSAR description.

d. Exercise of Discretion.

As provided in Section VII, "Exercise of Discretion," discretion may be exercised by either escalating or mitigating the amount of the civil penalty determined after applying the civil penalty adjustment factors to ensure that the proposed civil penalty reflects the NRC's concern regarding the violation at issue and that it conveys the appropriate message to the licensee. However, in no instance will a civil penalty for any one violation exceed \$110,000 per day.

TABLE 1A--BASE CIVIL PENALTIES

a. Power reactors and gaseous diffusion plants.....	\$110,000
b. Fuel fabricators, industrial processors, and independent spent fuel and monitored retrievable storage installations.....	\$27,500
c. Test reactors, mills and uranium conversion facilities, contractors, vendors, waste disposal licensees, and industrial radiographers.....	\$11,000
d. Research reactors, academic, medical, or other material licensee.....	\$5,500

¹ This applies to nonprofit institutions not

otherwise categorized in this table, mobile nuclear services, nuclear pharmacies, and physician offices.

TABLE 1B--BASE CIVIL PENALTIES

Severity Level	Base Civil Penalty Amount (Percent of amount listed in Table 1A)
I	100%
II	80%
III	50%

C. Orders

An order is a written NRC directive to modify, suspend, or revoke a license; to cease and desist from a given practice or activity; or to take such other action as may be proper (see 10 CFR 2.202). Orders may also be issued in lieu of, or in addition to, civil penalties, as appropriate for Severity Level I, II, or III violations. Orders may be issued as follows:

1. License Modification orders are issued when some change in licensee equipment, procedures, personnel, or management controls is necessary.
2. Suspension Orders may be used:
 - (a) To remove a threat to the public health and safety, common defense and security, or the environment;
 - (b) To stop facility construction when,
 - (i) Further work could preclude or significantly hinder the identification or correction of an improperly constructed safety-related system or component; or
 - (ii) The licensee's quality assurance program implementation is not adequate to provide confidence that construction activities are being properly carried out;
 - (c) When the licensee has not responded adequately to other enforcement action;
 - (d) When the licensee interferes with the conduct of an inspection or investigation; or
 - (e) For any reason not mentioned above for which license revocation is legally authorized.

Suspensions may apply to all or part of

the licensed activity. Ordinarily, a licensed activity is not suspended (nor is a suspension prolonged) for failure to comply with requirements where such failure is not willful and adequate corrective action has been taken.

3. Revocation Orders may be used:
 - (a) When a licensee is unable or unwilling to comply with NRC requirements;
 - (b) When a licensee refuses to correct a violation;
 - (c) When licensee does not respond to a Notice of Violation where a response was required;
 - (d) When a licensee refuses to pay an applicable fee under the Commission's regulations; or
 - (e) For any other reason for which revocation is authorized under section 186 of the Atomic Energy Act (e.g., any condition which would warrant refusal of a license on an original application).
4. Cease and Desist Orders may be used to stop an unauthorized activity that has continued after notification by the NRC that the activity is unauthorized.
5. Orders to unlicensed persons, including vendors and contractors, and employees of any of them, are used when the NRC has identified deliberate misconduct that may cause a licensee to be in violation of an NRC requirement or where incomplete or inaccurate information is deliberately submitted or where the NRC loses its reasonable assurance that the licensee will meet NRC requirements with that person involved in licensed activities.

Unless a separate response is warranted pursuant to 10 CFR 2.201, a Notice of Violation need not be issued where an order is based on violations described in the order. The violations described in an order need not be categorized by severity level.

Orders are made effective immediately, without prior opportunity for hearing, whenever it is determined that the public health, interest, or safety so requires, or when the order is responding to a violation involving willfulness. Otherwise, a prior opportunity for a hearing on the order is afforded. For cases in which the NRC believes a basis could reasonably exist for

not taking the action as proposed, the licensee will ordinarily be afforded an opportunity to show why the order should not be issued in the proposed manner by way of a Demand for Information. (See 10 CFR 2.204)

D. Related Administrative Actions

In addition to the formal enforcement actions, Notices of Violation, civil penalties, and orders, the NRC also uses administrative actions, such as Notices of Deviation, Notices of Nonconformance, Confirmatory Action Letters, Letters of Reprimand, and Demands for Information to supplement its enforcement program. The NRC expects licensees and vendors to adhere to any obligations and commitments resulting from these actions and will not hesitate to issue appropriate orders to ensure that these obligations and commitments are met.

1. Notices of Deviation are written notices describing a licensee's failure to satisfy a commitment where the commitment involved has not been made a legally binding requirement. A Notice of Deviation requests a licensee to provide a written explanation or statement describing corrective steps taken (or planned), the results achieved, and the date when corrective action will be completed.
2. Notices of Nonconformance are written notices describing vendor's failures to meet commitments which have not been made legally binding requirements by NRC. An example is a commitment made in a procurement contract with a licensee as required by 10 CFR Part 50, Appendix B. Notices of Nonconformances request non-licensees to provide written explanations or statements describing corrective steps (taken or planned), the results achieved, the dates when corrective actions will be completed, and measures taken to preclude recurrence.
3. Confirmatory Action Letters are

letters confirming a licensee's or vendor's agreement to take certain actions to remove significant concerns about health and safety, safeguards, or the environment.

4. Letters of Reprimand are letters addressed to individuals subject to Commission jurisdiction identifying a significant deficiency in their performance of licensed activities.

5. Demands for Information are demands for information from licensees or other persons for the purpose of enabling the NRC to determine whether an order or other enforcement action should be issued.

VII. EXERCISE OF DISCRETION

Notwithstanding the normal guidance contained in this policy, as provided in Section III, "Responsibilities," the NRC may choose to exercise discretion and either escalate or mitigate enforcement sanctions within the Commission's statutory authority to ensure that the resulting enforcement action appropriately reflects the level of NRC concern regarding the violation at issue and conveys the appropriate message to the licensee.

A. Escalation of Enforcement Sanctions

The NRC considers violations categorized at Severity Level I, II, or III to be of significant regulatory concern. If the application of the normal guidance in this policy does not result in an appropriate sanction, with the approval of the Deputy Executive Director and consultation with the EDO and Commission, as warranted, the NRC may apply its full enforcement authority where the action is warranted. NRC action may include (1) escalating civil penalties, (2) issuing appropriate orders, and (3) assessing civil penalties for continuing violations on a per day basis, up to the statutory limit of \$110,000 per violation, per day.

1. **Civil penalties.** Notwithstanding the outcome of the normal civil penalty

assessment process addressed in Section VI.B, the NRC may exercise discretion by either proposing a civil penalty where application of the factors would otherwise result in zero penalty or by escalating the amount of the resulting civil penalty (i.e., base or twice the base civil penalty) to ensure that the proposed civil penalty reflects the significance of the circumstances and conveys the appropriate regulatory message to the licensee. The Commission will be notified if the deviation in the amount of the civil penalty proposed under this discretion from the amount of the civil penalty assessed under the normal process is more than two times the base civil penalty shown in Tables 1A and 1B. Examples when this discretion should be considered include, but are not limited to the following:

(a) Problems categorized at Severity Level I or II;

(b) Overexposures, or releases of radiological material in excess of NRC requirements;

(c) Situations involving particularly poor licensee performance, or involving willfulness;

(d) Situations when the licensee's previous enforcement history has been particularly poor, or when the current violation is directly repetitive of an earlier violation;

(e) Situations when the violation results in a substantial increase in risk, including cases in which the duration of the violation has contributed to the substantial increase;

(f) Situations when the licensee made a conscious decision to be in noncompliance in order to obtain an economic benefit;

(g) Cases involving the loss of a source. In addition, unless the licensee self-identifies and reports the loss to the NRC, these cases should normally result in a civil penalty in an amount at least in the order of the cost of an authorized disposal of the material or of the transfer of the material to an authorized recipient; or

(h) Severity Level II or III violations associated with departures from the Final Safety Analysis Report identified after two years from October 18, 1996. Such a

violation or problem would consider the number and nature of the violations, the severity of the violations, whether the violations were continuing, and who identified the violations (and if the licensee identified the violation, whether exercise of Section VII.B.3 enforcement discretion is warranted).

2. **Orders.** The NRC may, where necessary or desirable, issue orders in conjunction with or in lieu of civil penalties to achieve or formalize corrective actions and to deter further recurrence of serious violations.

3. **Daily civil penalties.** In order to recognize the added technical safety significance or regulatory significance for those cases where a very strong message is warranted for a significant violation that continues for more than one day, the NRC may exercise discretion and assess a separate violation and attendant civil penalty up to the statutory limit of \$110,000 for each day the violation continues. The NRC may exercise this discretion if a licensee was aware or clearly should have been aware of a violation, or if the licensee had an opportunity to identify and correct the violation but failed to do so.

B. Mitigation of Enforcement Sanctions

The NRC may exercise discretion and refrain from issuing a civil penalty and/or a Notice of Violation, if the outcome of the normal process described in Section VI.B does not result in a sanction consistent with an appropriate regulatory message. However, even if the NRC exercises this discretion, when the licensee failed to make a required report to the NRC, a separate enforcement action will normally be issued for the licensee's failure to make a required report. The approval of the Director, Office of Enforcement, with consultation with the Deputy Executive Director as warranted, is required for exercising

discretion of the type described in Section VII.B.1.b where a willful violation is involved, and of the types described in Sections VII.B.2 through VII.B.6. Commission notification is required for exercising discretion of the type described in: (1) Section VII.B.2 the first time discretion is exercised during that plant shutdown, and (2) Section VII.B.6 where appropriate based on the uniqueness or significance of the issue. Examples when discretion should be considered for departing from the normal approach in Section VI.B include but are not limited to the following:

1. Licensee-Identified Severity Level IV Violations. The NRC, with the approval of the Regional Administrator or his or her designee, may refrain from issuing a Notice of Violation for a Severity Level IV violation that is documented in an inspection report (or official field notes for some material cases) and described therein as a Non-Cited Violation (NCV) provided that the inspection report includes a brief description of the corrective action and that the violation meets all of the following criteria:

- (a) It was identified by the licensee;
- (b) It was not a violation that could reasonably be expected to have been prevented by the licensee's corrective action for a previous violation or a previous licensee finding that occurred within the past 2 years of the inspection at issue, or the period within the last two inspections, whichever is longer;
- (c) It was or will be corrected within a reasonable time, by specific corrective action committed to by the licensee by the end of the inspection, including immediate corrective action and comprehensive corrective action to prevent recurrence;
- (d) It was not a willful violation or if it was a willful violation;

(i) The information concerning the violation, if not required to be reported, was promptly provided to appropriate NRC personnel, such as a resident inspector or regional section or branch

chief;

(ii) The violation involved the acts of a low-level individual (and not a licensee official as defined in Section IV.C);

(iii) The violation appears to be the isolated action of the employee without management involvement and the violation was not caused by lack of management oversight as evidenced by either a history of isolated willful violations or a lack of adequate audits or supervision of employees; and

(iv) Significant remedial action commensurate with the circumstances was taken by the licensee such that it demonstrated the seriousness of the violation to other employees and contractors, thereby creating a deterrent effect within the licensee's organization. Although removal of the employee from licensed activities is not necessarily required, substantial disciplinary action is expected.

2. Violations Identified During Extended Shutdowns or Work Stoppages. The NRC may refrain from issuing a Notice of Violation or a proposed civil penalty for a violation that is identified after (i) the NRC has taken significant enforcement action based upon a major safety event contributing to an extended shutdown of an operating reactor or a material licensee (or a work stoppage at a construction site), or (ii) the licensee enters an extended shutdown or work stoppage related to generally poor performance over a long period of time, provided that the violation is documented in an inspection report (or official field notes for some material cases) and that it meets all of the following criteria:

(a) It was either licensee-identified as a result of a comprehensive program for problem identification and correction that was developed in response to the shutdown or identified as a result of an employee allegation to the licensee; (If the NRC identifies the violation and all of the other criteria are met, the NRC should determine whether enforcement action is necessary to achieve remedial action, or if discretion may still be appropriate.)

(b) It is based upon activities of the licensee prior to the events leading to the shutdown;

(c) It would not be categorized at a severity level higher than Severity Level II;

(d) It was not willful; and

(e) The licensee's decision to restart the plant requires NRC concurrence.

3. Violations Involving Old Design Issues. The NRC may refrain from proposing a civil penalty for a Severity Level II or III violation involving a past problem, such as in engineering, design, or installation, provided that the violation is documented in an inspection report (or official field notes for some material cases) that includes a description of the corrective action and that it meets all of the following criteria:

(a) It was a licensee-identified as a result of its voluntary initiative;

(b) It was or will be corrected, including immediate corrective action and long term comprehensive corrective action to prevent recurrence, within a reasonable time following identification (this action should involve expanding the initiative, as necessary, to identify other failures caused by similar root causes); and

(c) It was not likely to be identified (after the violation occurred) by routine licensee efforts such as normal surveillance or quality assurance (QA) activities.

In addition, the NRC may refrain from issuing a Notice of Violation for cases that meet the above criteria provided the violation was caused by conduct that is not reasonably linked to present performance (normally, violations that are at least 3 years old or violations occurring during plant construction) and there had not been prior notice so that the licensee should have reasonably identified the violation earlier. This exercise of discretion is to place a premium on licensees initiating efforts to identify and correct subtle violations that are not likely to

be identified by routine efforts before degraded safety systems are called upon to work.

Section VII.B.3 discretion would not normally be applied to departures from the FSAR if:

(a) The NRC identifies the violation unless it was likely in the staff's view that the licensee would have identified the violation in light of the defined scope, thoroughness, and schedule of the licensee's initiative (provided the schedule provides for completion of the licensee's initiative within two years after October 18, 1996;

(b) The licensee identifies the violation as a result of an event or surveillance or other required testing where required corrective action identifies the FSAR issue;

(c) The licensee identifies the violation but had prior opportunities to do so (was aware of the departure from the FSAR) and failed to correct it earlier;

(d) There is willfulness associated with the violation;

(e) The licensee fails to make a report required by the identification of the departure from the FSAR; or

(f) The licensee either fails to take comprehensive corrective action or fails to appropriately expand the corrective action program. The corrective action should be broad with a defined scope and schedule.

4. Violations Identified Due to Previous Escalated Enforcement Action. The NRC may refrain from issuing a Notice of Violation or a proposed civil penalty for a violation that is identified after the NRC has taken escalated enforcement action for a Severity Level II or III violation, provided that the violation is documented in an inspection report (or official field notes for some material cases) that includes a description of the corrective action and that it meets all of the following criteria:

(a) It was licensee-identified as part of the corrective action for the previous escalated enforcement action;

(b) It has the same or similar root

cause as the violation for which escalated enforcement action was issued;

(c) It does not substantially change the safety significance or the character of the regulatory concern arising out of the initial violation; and

(d) It was or will be corrected, including immediate corrective action and long term comprehensive corrective action to prevent recurrence, within a reasonable time following identification.

5. Violations Involving Certain Discrimination Issues. Enforcement discretion may be exercised for discrimination cases when a licensee who, without the need for government intervention, identifies an issue of discrimination and takes prompt, comprehensive, and effective corrective action to address both the particular situation and the overall work environment for raising safety concerns. Similarly, enforcement may not be warranted where a complaint is filed with the Department of Labor (DOL) under Section 211 of the Energy Reorganization Act of 1974, as amended, but the licensee settles the matter before the DOL makes an initial finding of discrimination and addresses the overall work environment. Alternatively, if a finding of discrimination is made, the licensee may choose to settle the case before the evidentiary hearing begins. In such cases, the NRC may exercise its discretion not to take enforcement action when the licensee has addressed the overall work environment for raising safety concerns and has publicized that a complaint of discrimination for engaging in protected activity was made to the DOL, that the matter was settled to the satisfaction of the employee (the terms of the specific settlement agreement need not be posted), and that, if the DOL Area Office found discrimination, the licensee has taken action to positively reemphasize that discrimination will not be tolerated.

Similarly, the NRC may refrain from taking enforcement action if a licensee settles a matter promptly after a person comes to the NRC without going to the DOL. Such discretion would normally not be exercised

in cases in which the licensee does not appropriately address the overall work environment (e.g., by using training, postings, revised policies or procedures, any necessary disciplinary action, etc., to communicate its policy against discrimination) or in cases that involve: allegations of discrimination as a result of providing information directly to the NRC, allegations of discrimination caused by a manager above first-line supervisor (consistent with current Enforcement Policy classification of Severity Level I or II violations), allegations of discrimination where a history of findings of discrimination (by the DOL or the NRC) or settlements suggests a programmatic rather than an isolated discrimination problem, or allegations of discrimination which appear particularly blatant or egregious.

6. Violations Involving Special Circumstances. Notwithstanding the outcome of the normal civil penalty assessment process addressed in Section VI.B, as provided in Section III, "Responsibilities," the NRC may reduce or refrain from issuing a civil penalty or a Notice of Violation for a Severity Level II or III violation based on the merits of the case after considering the guidance in this statement of policy and such factors as the age of the violation, the safety significance of the violation, the overall sustained performance of the licensee has been particularly good, and other relevant circumstances, including any that may have changed since the violation. This discretion is expected to be exercised only where application of the normal guidance in the policy is unwarranted.

C. Exercise of Discretion for an Operating Facility

On occasion, circumstances may arise where a licensee's compliance with a Technical Specification (TS) Limiting Condition for Operation or with other

license conditions would involve an unnecessary plant transient or performance of testing, inspection, or system realignment that is inappropriate with the specific plant conditions, or unnecessary delays in plant startup without a corresponding health and safety benefit. In these circumstances, the NRC staff may choose not to enforce the applicable TS or other license condition. This enforcement discretion, designated as a Notice of Enforcement Discretion (NOED), will only be exercised if the NRC staff is clearly satisfied that the action is consistent with protecting the public health and safety. A licensee seeking the issuance of a NOED must provide a written justification, or in circumstances where good cause is shown, oral justification followed as soon as possible by written justification, which documents the safety basis for the request and provides whatever other information the NRC staff deems necessary in making a decision on whether or not to issue a NOED.

The appropriate Regional Administrator, or his or her designee, may issue a NOED where the noncompliance is temporary and nonrecurring when an amendment is not practical. The Director, Office of Nuclear Reactor Regulation, or his or her designee, may issue a NOED if the expected noncompliance will occur during the brief period of time it requires the NRC staff to process an emergency or exigent license amendment under the provisions of 10 CFR 50.91(a)(5) or (6). The person exercising enforcement discretion will document the decision.

For an operating plant, this exercise of enforcement discretion is intended to minimize the potential safety consequences of unnecessary plant transients with the accompanying operational risks and impacts or to eliminate testing, inspection, or system realignment which is inappropriate for the particular plant conditions. For

plants in a shutdown condition, exercising enforcement discretion is intended to reduce shutdown risk by, again, avoiding testing, inspection or system realignment which is inappropriate for the particular plant conditions, in that, it does not provide a safety benefit or may, in fact, be detrimental to safety in the particular plant condition. Exercising enforcement discretion for plants attempting to startup is less likely than exercising it for an operating plant, as simply delaying startup does not usually leave the plant in a condition in which it could experience undesirable transients. In such cases, the Commission would expect that discretion would be exercised with respect to equipment or systems only when it has at least concluded that, notwithstanding the conditions of the license: (1) The equipment or system does not perform a safety function in the mode in which operation is to occur; (2) the safety function performed by the equipment or system is of only marginal safety benefit, provided remaining in the current mode increases the likelihood of an unnecessary plant transient; or (3) the TS or other license condition requires a test, inspection or system realignment that is inappropriate for the particular plant conditions, in that it does not provide a safety benefit, or may, in fact, be detrimental to safety in the particular plant condition.

The decision to exercise enforcement discretion does not change the fact that a violation will occur nor does it imply that enforcement discretion is being exercised for any violation that may have led to the violation at issue. In each case where the NRC staff has chosen to issue a NOED, enforcement action will normally be taken for the root causes, to the extent violations were involved, that led to the noncompliance for which enforcement discretion was used. The enforcement action is intended to emphasize that licensees should not rely on the NRC's authority to exercise enforcement discretion as a routine substitute for compliance or for requesting a license amendment.

Finally, it is expected that the NRC staff

will exercise enforcement discretion in this area infrequently. Although a plant must shut down, refueling activities may be suspended, or plant startup may be delayed, absent the exercise of enforcement discretion, the NRC staff is under no obligation to take such a step merely because it has been requested. The decision to forego enforcement is discretionary. When enforcement discretion is to be exercised, it is to be exercised only if the NRC staff is clearly satisfied that such action is warranted from a health and safety perspective.

VIII. ENFORCEMENT ACTIONS INVOLVING INDIVIDUALS

Enforcement actions involving individuals, including licensed operators, are significant personnel actions, which will be closely controlled and judiciously applied. An enforcement action involving an individual will normally be taken only when the NRC is satisfied that the individual fully understood, or should have understood, his or her responsibility; knew, or should have known, the required actions; and knowingly, or with careless disregard (i.e., with more than mere negligence) failed to take required actions which have actual or potential safety significance. Most transgressions of individuals at the level of Severity Level III or IV violations will be handled by citing only the facility licensee.

More serious violations, including those involving the integrity of an individual (e.g., lying to the NRC) concerning matters within the scope of the individual's responsibilities, will be considered for enforcement action against the individual as well as against the facility licensee. Action against the individual, however, will not be taken if the improper action by the individual was caused by management failures. The following examples of situations illustrate this concept:

- Inadvertent individual mistakes resulting from inadequate training or guidance provided by the facility licensee.

- Inadvertently missing an insignificant procedural requirement when the action is routine, fairly uncomplicated, and there is no unusual circumstance indicating that the procedures should be referred to and followed step-by-step.

- Compliance with an express direction of management, such as the Shift Supervisor or Plant Manager, resulted in a violation unless the individual did not express his or her concern or objection to the direction.

- Individual error directly resulting from following the technical advice of an expert unless the advice was clearly unreasonable and the licensed individual should have recognized it as such.

- Violations resulting from inadequate procedures unless the individual used a faulty procedure knowing it was faulty and had not attempted to get the procedure corrected.

Listed below are examples of situations which could result in enforcement actions involving individuals, licensed or unlicensed. If the actions described in these examples are taken by a licensed operator or taken deliberately by an unlicensed individual, enforcement action may be taken directly against the individual. However, violations involving willful conduct not amounting to deliberate action by an unlicensed individual in these situations may result in enforcement action against a licensee that may impact an individual. The situations include, but are not limited to, violations that involve:

- Willfully causing a licensee to be in violation of NRC requirements.

- Willfully taking action that would have caused a licensee to be in violation of NRC requirements but the action did not do so because it was detected and corrective action was taken.

- Recognizing a violation of procedural requirements and willfully

not taking corrective action.

- Willfully defeating alarms which have safety significance.

- Unauthorized abandoning of reactor controls.

- Dereliction of duty.

- Falsifying records required by NRC regulations or by the facility license.

- Willfully providing, or causing a licensee to provide, an NRC inspector or investigator with inaccurate or incomplete information on a matter material to the NRC.

- Willfully withholding safety significant information rather than making such information known to appropriate supervisory or technical personnel in the licensee's organization.

- Submitting false information and as a result gaining unescorted access to a nuclear power plant.

- Willfully providing false data to a licensee by a contractor or other person who provides test or other services, when the data affects the licensee's compliance with 10 CFR part 50, appendix B, or other regulatory requirement.

- Willfully providing false certification that components meet the requirements of their intended use, such as ASME Code.

- Willfully supplying, by vendors of equipment for transportation of radioactive material, casks that do not comply with their certificates of compliance.

- Willfully performing unauthorized bypassing of required reactor or other facility safety systems.

- Willfully taking actions that violate Technical Specification Limiting Conditions for Operation or other license conditions (enforcement action for a willful violation will not be taken if that violation is the result of action taken following the NRC's decision to forego enforcement of the Technical Specification or other license condition or if the operator meets the requirements of 10 CFR 50.54 (x), (i.e., unless the operator acted unreasonably considering all the relevant circumstances surrounding the emergency.)

Normally, some enforcement action is taken against a licensee for violations

caused by significant acts of wrongdoing by its employees, contractors, or contractors' employees. In deciding whether to issue an enforcement action to an unlicensed person as well as to the licensee, the NRC recognizes that judgments will have to be made on a case by case basis. In making these decisions, the NRC will consider factors such as the following:

1. The level of the individual within the organization.

2. The individual's training and experience as well as knowledge of the potential consequences of the wrongdoing.

3. The safety consequences of the misconduct.

4. The benefit to the wrongdoer, e.g., personal or corporate gain.

5. The degree of supervision of the individual, i.e., how closely is the individual monitored or audited, and the likelihood of detection (such as a radiographer working independently in the field as contrasted with a team activity at a power plant).

6. The employer's response, e.g., disciplinary action taken.

7. The attitude of the wrongdoer, e.g., admission of wrongdoing, acceptance of responsibility.

8. The degree of management responsibility or culpability.

9. Who identified the misconduct.

Any proposed enforcement action involving individuals must be issued with the concurrence of the Deputy Executive Director. The particular sanction to be used should be determined on a case-by-case basis.¹⁰

¹⁰ Except for individuals subject to civil penalties under section 206 of the Energy Reorganization Act of 1974, as amended, NRC will not normally impose a civil penalty against an individual. However, section 234 of the Atomic Energy Act (AEA) gives the Commission authority to impose civil

Notices of Violation and Orders are examples of enforcement actions that may be appropriate against individuals. The administrative action of a Letter of Reprimand may also be considered. In addition, the NRC may issue Demands for Information to gather information to enable it to determine whether an order or other enforcement action should be issued.

Orders to NRC-licensed reactor operators may involve suspension for a specified period, modification, or revocation of their individual licenses. Orders to unlicensed individuals might include provisions that would:

- Prohibit involvement in NRC licensed activities for a specified period of time (normally the period of suspension would not exceed 5 years) or until certain conditions are satisfied, e.g., completing specified training or meeting certain qualifications.

- Require notification to the NRC before resuming work in licensed activities.

- Require the person to tell a prospective employer or customer engaged in licensed activities that the person has been subject to an NRC order.

In the case of a licensed operator's failure to meet applicable fitness-for-duty requirements (10 CFR 55.53(j)), the NRC may issue a Notice of Violation or a civil penalty to the Part 55 licensee, or an order to suspend, modify, or revoke the Part 55 license. These actions may be taken the first time a licensed operator fails a drug or

alcohol test, that is, receives a confirmed positive test that exceeds the cutoff levels of 10 CFR Part 26 or the facility licensee's cutoff levels, if lower. However, normally only a Notice of Violation will be issued for the first confirmed positive test in the absence of aggravating circumstances such as errors in the performance of licensed duties or evidence of prolonged use. In addition, the NRC intends to issue an order to suspend the Part 55 license for up to 3 years the second time a licensed operator exceeds those cutoff levels. In the event there are less than 3 years remaining in the term of the individual's license, the NRC may consider not renewing the individual's license or not issuing a new license after the three year period is completed. The NRC intends to issue an order to revoke the Part 55 license the third time a licensed operator exceeds those cutoff levels. A licensed operator or applicant who refuses to participate in the drug and alcohol testing programs established by the facility licensee or who is involved in the sale, use, or possession of an illegal drug is also subject to license suspension, revocation, or denial.

In addition, the NRC may take enforcement action against a licensee that may impact an individual, where the conduct of the individual places in question the NRC's reasonable assurance that licensed activities will be properly conducted. The NRC may take enforcement action for reasons that would warrant refusal to issue a license on an original application. Accordingly, appropriate enforcement actions may be taken regarding matters that raise issues of integrity, competence, fitness-for-duty, or other matters that may not necessarily be a violation of specific Commission requirements.

In the case of an unlicensed person, whether a firm or an individual, an order modifying the facility license may be issued to require (1) the removal of the person from all licensed activities for a specified period of time or indefinitely, (2) prior notice to the NRC before utilizing the person in licensed activities, or (3) the licensee to provide notice of the issuance of

such an order to other persons involved in licensed activities making reference inquiries. In addition, orders to employers might require retraining, additional oversight, or independent verification of activities performed by the person, if the person is to be involved in licensed activities.

IX. INACCURATE AND INCOMPLETE INFORMATION

A violation of the regulations involving submittal of incomplete and/or inaccurate information, whether or not considered a material false statement, can result in the full range of enforcement sanctions. The labeling of a communication failure as a material false statement will be made on a case-by-case basis and will be reserved for egregious violations.

Violations involving inaccurate or incomplete information or the failure to provide significant information identified by a licensee normally will be categorized based on the guidance herein, in Section IV, "Severity of Violations," and in Supplement VII.

The Commission recognizes that oral information may in some situations be inherently less reliable than written submittals because of the absence of an opportunity for reflection and management review. However, the Commission must be able to rely on oral communications from licensee officials concerning significant information. Therefore, in determining whether to take enforcement action for an oral statement, consideration may be given to factors such as (1) the degree of knowledge that the communicator should have had, regarding the matter, in view of his or her position, training, and experience; (2) the opportunity and time available prior to the communication to assure the accuracy or completeness of the information; (3) the degree of intent or negligence, if any, involved; (4) the formality of the communication; (5) the reasonableness of NRC reliance on the information;

penalties on "any person." "Person" is broadly defined in Section 11s of the AEA to include individuals, a variety of organizations, and any representatives or agents. This gives the Commission authority to impose civil penalties on employees of licensees or on separate entities when a violation of a requirement directly imposed on them is committed.

(6) the importance of the information which was wrong or not provided; and (7) the reasonableness of the explanation for not providing complete and accurate information.

Absent at least careless disregard, an incomplete or inaccurate unsworn oral statement normally will not be subject to enforcement action unless it involves significant information provided by a licensee official. However, enforcement action may be taken for an unintentionally incomplete or inaccurate oral statement provided to the NRC by a licensee official or others on behalf of a licensee, if a record was made of the oral information and provided to the licensee thereby permitting an opportunity to correct the oral information, such as if a transcript of the communication or meeting summary containing the error was made available to the licensee and was not subsequently corrected in a timely manner.

When a licensee has corrected inaccurate or incomplete information, the decision to issue a Notice of Violation for the initial inaccurate or incomplete information normally will be dependent on the circumstances, including the ease of detection of the error, the timeliness of the correction, whether the NRC or the licensee identified the problem with the communication, and whether the NRC relied on the information prior to the correction. Generally, if the matter was promptly identified and corrected by the licensee prior to reliance by the NRC, or before the NRC raised a question about the information, no enforcement action will be taken for the initial inaccurate or incomplete information. On the other hand, if the misinformation is identified after the NRC relies on it, or after some question is raised regarding the accuracy of the information, then some enforcement action normally will be taken even if it is in fact corrected. However, if the initial submittal was accurate when made but later turns out to be erroneous

because of newly discovered information or advance in technology, a citation normally would not be appropriate if, when the new information became available or the advancement in technology was made, the initial submittal was corrected.

The failure to correct inaccurate or incomplete information which the licensee does not identify as significant normally will not constitute a separate violation. However, the circumstances surrounding the failure to correct may be considered relevant to the determination of enforcement action for the initial inaccurate or incomplete statement. For example, an unintentionally inaccurate or incomplete submission may be treated as a more severe matter if the licensee later determines that the initial submittal was in error and does not correct it or if there were clear opportunities to identify the error. If information not corrected was recognized by a licensee as significant, a separate citation may be made for the failure to provide significant information. In any event, in serious cases where the licensee's actions in not correcting or providing information raise questions about its commitment to safety or its fundamental trustworthiness, the Commission may exercise its authority to issue orders modifying, suspending, or revoking the license. The Commission recognizes that enforcement determinations must be made on a case-by-case basis, taking into consideration the issues described in this section.

X. ENFORCEMENT ACTION AGAINST NON-LICENSEES

The Commission's enforcement policy is also applicable to non-licensees, including employees of licensees, to contractors and subcontractors, and to employees of contractors and subcontractors, who knowingly provide components, equipment, or other goods or services that relate to a licensee's activities subject to NRC regulation. The prohibitions and sanctions for any of these persons who engage in deliberate misconduct or submission of incomplete or inaccurate information are

provided in the rule on deliberate misconduct, e.g., 10 CFR 30.10 and 50.5.

Vendors of products or services provided for use in nuclear activities are subject to certain requirements designed to ensure that the products or services supplied that could affect safety are of high quality. Through procurement contracts with reactor licensees, vendors may be required to have quality assurance programs that meet applicable requirements including 10 CFR Part 50, Appendix B, and 10 CFR Part 71, Subpart H. Vendors supplying products or services to reactor, materials, and 10 CFR Part 71 licensees are subject to the requirements of 10 CFR Part 21 regarding reporting of defects in basic components.

When inspections determine that violations of NRC requirements have occurred, or that vendors have failed to fulfill contractual commitments (e.g., 10 CFR Part 50, Appendix B) that could adversely affect the quality of a safety significant product or service, enforcement action will be taken. Notices of Violation and civil penalties will be used, as appropriate, for licensee failures to ensure that their vendors have programs that meet applicable requirements. Notices of Violation will be issued for vendors that violate 10 CFR Part 21. Civil penalties will be imposed against individual directors or responsible officers of a vendor organization who knowingly and consciously fail to provide the notice required by 10 CFR 21.21(b)(1). Notices of Nonconformance will be used for vendors which fail to meet commitments related to NRC activities.

XI. REFERRALS TO THE DEPARTMENT OF JUSTICE

Alleged or suspected criminal violations of the Atomic Energy Act (and of other relevant Federal laws) are referred to the Department of Justice

(DOJ) for investigation. Referral to the DOJ does not preclude the NRC from taking other enforcement action under this policy. However, enforcement actions will be coordinated with the DOJ in accordance with the Memorandum of Understanding between the NRC and the DOJ, 53 FR 50317 (December 14, 1988).

XII. PUBLIC DISCLOSURE OF ENFORCEMENT ACTIONS

Enforcement actions and licensees' responses, in accordance with 10 CFR 2.790, are publicly available for inspection. In addition, press releases are generally issued for orders and civil penalties and are issued at the same time the order or proposed imposition of the civil penalty is issued. In addition, press releases are usually issued when a proposed civil penalty is withdrawn or substantially mitigated by some amount. Press releases are not normally issued for Notices of Violation that are not accompanied by orders or proposed civil penalties.

XIII. REOPENING CLOSED ENFORCEMENT ACTIONS

If significant new information is received or obtained by NRC which indicates that an enforcement sanction was incorrectly applied, consideration may be given, dependent on the circumstances, to reopening a closed enforcement action to increase or decrease the severity of a sanction or to correct the record. Reopening decisions will be made on a case-by-case basis, are expected to occur rarely, and require the specific approval of the Deputy Executive Director.

SUPPLEMENT I— REACTOR OPERATIONS

This supplement provides examples of violations in each of the four severity levels as guidance in determining the appropriate severity level for violations

in the area of reactor operations.

A. Severity Level I - Violations involving for example:

1. A Safety Limit, as defined in 10 CFR 50.36 and the Technical Specifications being exceeded;
2. A system¹¹ designed to prevent or mitigate a serious safety event not being able to perform its intended safety function¹² when actually called upon to work;
3. An accidental criticality; or
4. A licensed operator at the controls of a nuclear reactor, or a senior operator directing licensed activities, involved in procedural errors which result in, or exacerbate the consequences of, an alert or higher level emergency and who, as a result of subsequent testing, receives a confirmed positive test result for drugs or alcohol.

B. Severity Level II - Violations involving for example:

1. A system designed to prevent or mitigate serious safety events not being able to perform its intended safety function;
2. A licensed operator involved in the use, sale, or possession of illegal drugs or the consumption of alcoholic beverages, within the protected area;
3. A licensed operator at the control of a nuclear reactor, or a senior operator directing licensed activities, involved in procedural errors and who, as a result of subsequent testing, receives a confirmed positive test result for drugs or alcohol; or
4. Failures to meet 10 CFR 50.59 including several unreviewed safety questions, or conflicts with technical specifications, involving a broad spectrum

¹¹ The term "system" as used in these supplements, includes administrative and managerial control systems, as well as physical systems.

¹² "Intended safety function" means the total safety function, and is not directed toward a loss of redundancy. A loss of one subsystem does not defeat the intended safety function as long as the other subsystem is operable.

of problems affecting multiple areas, some of which impact the operability of required equipment.

C. Severity Level III - Violations involving for example:

1. A significant failure to comply with the Action Statement for a Technical Specification Limiting Condition for Operation where the appropriate action was not taken within the required time, such as:

- (a) In a pressurized water reactor, in the applicable modes, having one high-pressure safety injection pump inoperable for a period in excess of that allowed by the action statement; or
- (b) In a boiling water reactor, one primary containment isolation valve inoperable for a period in excess of that allowed by the action statement.

2. A system designed to prevent or mitigate a serious safety event:

- (a) Not being able to perform its intended function under certain conditions (e.g., safety system not operable unless offsite power is available; materials or components not environmentally qualified); or
- (b) Being degraded to the extent that a detailed evaluation would be required to determine its operability (e.g., component parameters outside approved limits such as pump flow rates, heat exchanger transfer characteristics, safety valve lift setpoints, or valve stroke times);

3. Inattentiveness to duty on the part of licensed personnel;

4. Changes in reactor parameters that cause unanticipated reductions in margins of safety;

5. [Reserved]

6. A licensee failure to conduct adequate oversight of vendors resulting in the use of products or services that are of defective or indeterminate quality and that have safety significance;

7. A breakdown in the control of licensed activities involving a number of violations that are related (or, if isolated, that are recurring violations)

that collectively represent a potentially significant lack of attention or carelessness toward licensed responsibilities;

8. A licensed operator's confirmed positive test for drugs or alcohol that does not result in a Severity Level I or II violation;

9. Equipment failures caused by inadequate or improper maintenance that substantially complicates recovery from a plant transient;

10. The failure to meet 10 CFR 50.59 where an unreviewed safety question is involved, or a conflict with a technical specification, such that a license amendment is required;

11. The failure to perform the required evaluation under 10 CFR 50.59 prior to implementation of the change in those situations in which no unreviewed safety question existed, but an extensive evaluation would be needed before a licensee would have had a reasonable expectation that an unreviewed safety question did not exist;

12. Programmatic failures (i.e., multiple or recurring failures) to meet the requirements of 10 CFR 50.59 and/or 50.71(e) that show a significant lack of attention to detail, whether or not such failures involve an unreviewed safety question, resulting in a current safety or regulatory concern about the accuracy of the FSAR or a concern that 10 CFR 50.59 requirements are not being met. Application of this example requires weighing factors such as: a) the time period over which the violations occurred and existed, b) the number of failures, c) whether one or more systems, functions, or pieces of equipment were involved and the importance of such equipment, functions, or systems, and d) the potential significance of the failures;

13. The failure to update the FSAR as required by 10 CFR 50.71(e) where the unupdated FSAR was used in performing a 10 CFR 50.59 evaluation and as a result, an inadequate decision was made demonstrating a significant

regulatory concern; or

14. The failure to make a report required by 10 CFR 50.72 or 50.73 associated with (a) an unreviewed safety question, (b) a conflict with a technical specification, or (c) any other Severity Level III violation.

D. Severity Level IV - Violations involving for example:

1. A less significant failure to comply with the Action Statement for a Technical Specification Limiting Condition for Operation where the appropriate action was not taken within the required time, such as:

(a) In a pressurized water reactor, a 5% deficiency in the required volume of the condensate storage tank; or

(b) In a boiling water reactor, one subsystem of the two independent MSIV leakage control subsystems inoperable;

2. [Reserved]

3. A failure to meet regulatory requirements that have more than minor safety or environmental significance;

4. A failure to make a required Licensee Event Report;

5. Relatively isolated violations of 10 CFR 50.59 not involving severity level II or III violations that do not suggest a programmatic failure to meet 10 CFR 50.59. Relatively isolated violations or failures would include a number of recently discovered violations that occurred over a period of years and are not indicative of a programmatic safety concern with meeting 10 CFR 50.59 or 50.71(e);

6. A relatively isolated failure to document an evaluation where there is evidence that an adequate evaluation was performed prior to the change in the facility or procedures, or the conduct of an experiment or test;

7. A failure to update the FSAR as required by 10 CFR 50.71(e) where an adequate evaluation under 10 CFR 50.59 had been performed and documented; or

8. A past programmatic failure to meet 10 CFR 50.59 and/or 10 CFR 50.71(e) requirements not involving Severity Level II or III violations that does not reflect a current safety or regulatory concern about the accuracy of the FSAR or a concern that 10 CFR 50.59 requirements are not being

met.

E. Minor Violations

A failure to meet 10 CFR 50.59 requirements that involves a change to the FSAR description or procedure, or involves a test or experiment not described in the FSAR, where there was not a reasonable likelihood that the change to the facility or procedure or the conduct of the test or experiment would ever be an unreviewed safety question. In the case of a 10 CFR 50.71(e) violation, where a failure to update the FSAR would not have a material impact on safety or licensed activities. The focus of the minor violation is not on the actual change, test, or experiment, but on the potential safety role of the system, equipment, etc., that is being changed, tested, or experimented on.

SUPPLEMENT II—PART 50 FACILITY CONSTRUCTION

This supplement provides examples of violations in each of the four severity levels as guidance in determining the appropriate severity level for violations in the area of Part 50 facility construction.

A. Severity Level I - Violations involving structures or systems that are completed¹³ in such a manner that they would not have satisfied their intended safety related purpose.

B. Severity Level II - Violations involving for example:

1. A breakdown in the Quality Assurance (QA) program as exemplified by deficiencies in construction QA related to more than one work activity (e.g., structural, piping, electrical, foundations). These deficiencies normally involve the licensee's failure to conduct adequate

¹³ The term "completed" as used in this supplement means completion of construction including review and acceptance by the construction QA organization.

audits or to take prompt corrective action on the basis of such audits and normally involve multiple examples of deficient construction or construction of unknown quality due to inadequate program implementation; or

2. A structure or system that is completed in such a manner that it could have an adverse effect on the safety of operations.

C. Severity Level III - Violations involving for example:

1. A deficiency in a licensee QA program for construction related to a single work activity (e.g., structural, piping, electrical or foundations). This significant deficiency normally involves the licensee's failure to conduct adequate audits or to take prompt corrective action on the basis of such audits, and normally involves multiple examples of deficient construction or construction of unknown quality due to inadequate program implementation;

2. A failure to confirm the design safety requirements of a structure or system as a result of inadequate preoperational test program implementation; or

3. A failure to make a required 10 CFR 50.55(e) report.

D. Severity Level IV - Violations involving failure to meet regulatory requirements including one or more Quality Assurance Criterion not amounting to Severity Level I, II, or III violations that have more than minor safety or environmental significance.

SUPPLEMENT III-SAFEGUARDS

This supplement provides examples of violations in each of the four severity levels as guidance in determining the appropriate severity level for violations in the area of safeguards.

A. Severity Level I - Violations involving for example:

1. An act of radiological sabotage in which the security system did not function as required and, as a result of the failure, there was a significant event, such as:

(a) A Safety Limit, as defined in 10 CFR 50.36 and the Technical Specifications, was exceeded;

(b) A system designed to prevent or mitigate a serious safety event was not able to perform its intended safety function when actually called upon to work; or

(c) An accidental criticality occurred;

2. The theft, loss, or diversion of a formula quantity¹⁴ of special nuclear material (SNM); or

3. Actual unauthorized production of a formula quantity of SNM

B. Severity Level II - Violations involving for example:

1. The entry of an unauthorized individual¹⁵ who represents a threat into a vital area¹⁶ from outside the protected area;

2. The theft, loss or diversion of SNM of moderate strategic significance¹⁷ in which the security system did not function as required; or

3. Actual unauthorized production of SNM.

C. Severity Level III - Violations involving for example:

1. A failure or inability to control access through established systems or procedures, such that an unauthorized individual (i.e., not authorized unescorted access to protected area) could easily gain undetected

access¹⁸ into a vital area from outside the protected area;

2. A failure to conduct any search at the access control point or conducting an inadequate search that resulted in the introduction to the protected area of firearms, explosives, or incendiary devices and reasonable facsimiles thereof that could significantly assist radiological sabotage or theft of strategic SNM;

3. A failure, degradation, or other deficiency of the protected area intrusion detection or alarm assessment systems such that an unauthorized individual who represents a threat could predictably circumvent the system or defeat a specific zone with a high degree of confidence without insider knowledge, or other significant degradation of overall system capability;

4. A significant failure of the safeguards systems designed or used to prevent or detect the theft, loss, or diversion of strategic SNM;

5. A failure to protect or control classified or safeguards information considered to be significant while the information is outside the protected area and accessible to those not authorized access to the protected area;

6. A significant failure to respond to an event either in sufficient time to provide protection to vital equipment or strategic SNM, or with an adequate response force;

7. A failure to perform an appropriate evaluation or background investigation so that information relevant to the access determination was not obtained or considered and as a result a person, who would likely not have been granted access by the licensee, if the required investigation or evaluation had been performed, was

¹⁴ See 10 CFR 73.2 for the definition of "formula quantity."

¹⁵ The term "unauthorized individual" as used in this supplement means someone who was not authorized for entrance into the area in question, or not authorized to enter in the manner entered.

¹⁶ The phrase "vital area" as used in this supplement includes vital areas and material access areas.

¹⁷ See 10 CFR 73.2 for the definition of "special nuclear material of moderate strategic significance."

¹⁸ In determining whether access can be easily gained, factors such as predictability, identifiability, and ease of passage should be considered.

granted access; or

8. A breakdown in the security program involving a number of violations that are related (or, if isolated, that are recurring violations) that collectively reflect a potentially significant lack of attention or carelessness toward licensed responsibilities.

D. Severity Level IV - Violations involving for example:

1. A failure or inability to control access such that an unauthorized individual (i.e., authorized to protected area but not to vital area) could easily gain undetected access into a vital area from inside the protected area or into a controlled access area;

2. A failure to respond to a suspected event in either a timely manner or with an adequate response force;

3. A failure to implement 10 CFR Parts 25 and 95 with respect to the information addressed under Section 142 of the Act, and the NRC approved security plan relevant to those parts;

4. A failure to make, maintain, or provide log entries in accordance with 10 CFR 73.71 (c) and (d), where the omitted information (i) is not otherwise available in easily retrievable records, and (ii) significantly contributes to the ability of either the NRC or the licensee to identify a programmatic breakdown;

5. A failure to conduct a proper search at the access control point;

6. A failure to properly secure or protect classified or safeguards information inside the protected area which could assist an individual in an act of radiological sabotage or theft of strategic SNM where the information was not removed from the protected area;

7. A failure to control access such that an opportunity exists that could allow unauthorized and undetected access into the protected area but which was neither easily or likely to be exploitable;

8. A failure to conduct an adequate search at the exit from a material access

area;

9. A theft or loss of SNM of low strategic significance that was not detected within the time period specified in the security plan, other relevant document, or regulation; or

10. Other violations that have more than minor safeguards significance.

SUPPLEMENT IV--HEALTH PHYSICS (10 CFR PART 20)

This supplement provides examples of violations in each of the four severity levels as guidance in determining the appropriate severity level for violations in the area of health physics, 10 CFR Part 20.¹⁹

A. Severity Level I - Violations involving for example:

1. A radiation exposure during any year of a worker in excess of 25 rems total effective dose equivalent, 75 rems to the lens of the eye, or 250 rads to the skin of the whole body, or to the feet, ankles, hands or forearms, or to any other organ or tissue;

2. A radiation exposure over the gestation period of the embryo/fetus of a declared pregnant woman in excess of 2.5 rems total effective dose equivalent;

3. A radiation exposure during any year of a minor in excess of 2.5 rems total effective dose equivalent, 7.5 rems to the lens of the eye, or 25 rems to the skin of the whole body, or to the feet, ankles, hands or forearms, or to any other organ or tissue;

4. An annual exposure of a member of the public in excess of 1.0 rem total effective dose equivalent;

5. A release of radioactive material to an unrestricted area at concentrations in excess of 50 times the limits for members of the public as described in 10 CFR 20.1302(b)(2)(i); or

6. Disposal of licensed material in quantities or concentrations in excess of 10 times the limits of 10 CFR 20.2003.

¹⁹ Personnel overexposures and associated violations incurred during a life-saving or other emergency response effort will be treated on a case-by-case basis.

B. Severity Level II - Violations involving for example:

1. A radiation exposure during any year of a worker in excess of 10 rems total effective dose equivalent, 30 rems to the lens of the eye, or 100 rems to the skin of the whole body, or to the feet, ankles, hands or forearms, or to any other organ or tissue;

2. A radiation exposure over the gestation period of the embryo/fetus of a declared pregnant woman in excess of 1.0 rem total effective dose equivalent;

3. A radiation exposure during any year of a minor in excess of 1 rem total effective dose equivalent; 3.0 rems to the lens of the eye, or 10 rems to the skin of the whole body, or to the feet, ankles, hands or forearms, or to any other organ or tissue;

4. An annual exposure of a member of the public in excess of 0.5 rem total effective dose equivalent;

5. A release of radioactive material to an unrestricted area at concentrations in excess of 10 times the limits for members of the public as described in 10 CFR 20.1302(b)(2)(i) (except when operation up to 0.5 rem a year has been approved by the Commission under Section 20.1301(c));

6. Disposal of licensed material in quantities or concentrations in excess of five times the limits of 10 CFR 20.2003; or

7. A failure to make an immediate notification as required by 10 CFR 20.2202 (a)(1) or (a)(2).

C. Severity Level III - Violations involving for example:

1. A radiation exposure during any year of a worker in excess of 5 rems total effective dose equivalent, 15 rems to the lens of the eye, or 50 rems to the skin of the whole body or to the feet, ankles, hands or forearms, or to any other organ or tissue;

2. A radiation exposure over the gestation period of the embryo/fetus of a declared pregnant woman in excess of 0.5 rem total effective dose equivalent (except when doses are in accordance

with the provisions of Section 20.1208(d));

3. A radiation exposure during any year of a minor in excess of 0.5 rem total effective dose equivalent; 1.5 rems to the lens of the eye, or 5 rems to the skin of the whole body, or to the feet, ankles, hands or forearms, or to any other organ or tissue;

4. A worker exposure above regulatory limits when such exposure reflects a programmatic (rather than an isolated) weakness in the radiation control program;

5. An annual exposure of a member of the public in excess of 0.1 rem total effective dose equivalent (except when operation up to 0.5 rem a year has been approved by the Commission under Section 20.1301(c));

6. A release of radioactive material to an unrestricted area at concentrations in excess of two times the effluent concentration limits referenced in 10 CFR 20.1302(b)(2)(i) (except when operation up to 0.5 rem a year has been approved by the Commission under Section 20.1301(c));

7. A failure to make a 24-hour notification required by 10 CFR 20.2202(b) or an immediate notification required by 10 CFR 20.2201(a)(1)(i);

8. A substantial potential for exposures or releases in excess of the applicable limits in 10 CFR Part 20 Sections 20.1001-20.2401 whether or not an exposure or release occurs;

9. Disposal of licensed material not covered in Severity Levels I or II;

10. A release for unrestricted use of contaminated or radioactive material or equipment that poses a realistic potential for exposure of the public to levels or doses exceeding the annual dose limits for members of the public, or that reflects a programmatic (rather than an isolated) weakness in the radiation control program;

11. Conduct of licensee activities by a technically unqualified person;

12. A significant failure to control

licensed material; or

13. A breakdown in the radiation safety program involving a number of violations that are related (or, if isolated, that are recurring) that collectively represent a potentially significant lack of attention or carelessness toward licensed responsibilities.

D. Severity Level IV - Violations involving for example:

1. Exposures in excess of the limits of 10 CFR 20.1201, 20.1207, or 20.1208 not constituting Severity Level I, II, or III violations;

2. A release of radioactive material to an unrestricted area at concentrations in excess of the limits for members of the public as referenced in 10 CFR 20.1302(b)(2)(i) (except when operation up to 0.5 rem a year has been approved by the Commission under Section 20.1301(c));

3. A radiation dose rate in an unrestricted or controlled area in excess of 0.002 rem in any 1 hour (2 millirem/hour) or 50 millirems in a year;

4. Failure to maintain and implement radiation programs to keep radiation exposures as low as is reasonably achievable;

5. Doses to a member of the public in excess of any EPA generally applicable environmental radiation standards, such as 40 CFR Part 190;

6. A failure to make the 30-day notification required by 10 CFR 20.2201(a)(1)(ii) or 20.2203(a);

7. A failure to make a timely written report as required by 10 CFR 20.2201(b), 20.2204, or 20.2206;

8. A failure to report an exceedance of the dose constraint established in 10 CFR 20.1101(d) or a failure to take corrective action for an exceedance, as required by 10 CFR 20.1101(d); or

9. Any other matter that has more than a minor safety, health, or environmental significance.

SUPPLEMENT V - TRANSPORTATION

This supplement provides examples of violations in each of the four severity levels as guidance in determining the appropriate

severity level for violations in the area of NRC transportation requirements²⁰.

A. Severity Level I - Violations involving for example:

1. Failure to meet transportation requirements that resulted in loss of control of radioactive material with a breach in package integrity such that the material caused a radiation exposure to a member of the public and there was clear potential for the public to receive more than .1 rem to the whole body;

2. Surface contamination in excess of 50 times the NRC limit; or

3. External radiation levels in excess of 10 times the NRC limit.

B. Severity Level II - Violations involving for example:

1. Failure to meet transportation requirements that resulted in loss of control of radioactive material with a breach in package integrity such that there was a clear potential for the member of the public to receive more than .1 rem to the whole body;

2. Surface contamination in excess of 10, but not more than 50 times the NRC limit;

3. External radiation levels in excess of five, but not more than 10 times the NRC limit; or

4. A failure to make required initial notifications associated with Severity Level I or II violations.

C. Severity Level III - Violations involving for example:

1. Surface contamination in excess of five but not more than 10 times the NRC limit;

²⁰ Some transportation requirements are applied to more than one licensee involved in the same activity such as a shipper and a carrier. When a violation of such a requirement occurs, enforcement action will be directed against the responsible licensee which, under the circumstances of the case, may be one or more of the licensees involved.

2. External radiation in excess of one but not more than five times the NRC limit;

3. Any noncompliance with labeling, placarding, shipping paper, packaging, loading, or other requirements that could reasonably result in the following:

- (a) A significant failure to identify the type, quantity, or form of material;
- (b) A failure of the carrier or recipient to exercise adequate controls; or
- (c) A substantial potential for either personnel exposure or contamination above regulatory limits or improper transfer of material;

4. A failure to make required initial notification associated with Severity Level III violations; or

5. A breakdown in the licensee's program for the transportation of licensed material involving a number of violations that are related (or, if isolated, that are recurring violations) that collectively reflect a potentially significant lack of attention or carelessness toward licensed responsibilities.

D. Severity Level IV - Violations involving for example:

1. A breach of package integrity without external radiation levels exceeding the NRC limit or without contamination levels exceeding five times the NRC limits;

2. Surface contamination in excess of but not more than five times the NRC limit;

3. A failure to register as an authorized user of an NRC-Certified Transport package;

4. A noncompliance with shipping papers, marking, labeling, placarding, packaging or loading not amounting to a Severity Level I, II, or III violation;

5. A failure to demonstrate that packages for special form radioactive material meets applicable regulatory requirements;

6. A failure to demonstrate that packages meet DOT Specifications for 7A Type A packages; or

7. Other violations that have more

than minor safety or environmental significance.

SUPPLEMENT VI-FUEL CYCLE AND MATERIALS OPERATIONS

This supplement provides examples of violations in each of the four severity levels as guidance in determining the appropriate severity level for violations in the area of fuel cycle and materials operations.

A. Severity Level I - Violations involving for example:

1. Radiation levels, contamination levels, or releases that exceed 10 times the limits specified in the license;

2. A system designed to prevent or mitigate a serious safety event not being operable when actually required to perform its design function;

3. A nuclear criticality accident;

4. A failure to follow the procedures of the quality management program, required by 10 CFR 35.32, that results in a death or serious injury (e.g., substantial organ impairment) to a patient;

5. A safety limit, as defined in 10 CFR 76.4, the Technical Safety Requirements, or the application being exceeded; or

6. Significant injury or loss of life due to a loss of control over licensed or certified activities, including chemical processes that are integral to the licensed or certified activity, whether radioactive material is released or not.

B. Severity Level II - Violations involving for example:

1. Radiation levels, contamination levels, or releases that exceed five times the limits specified in the license;

2. A system designed to prevent or mitigate a serious safety event being inoperable;

3. A substantial programmatic failure in the implementation of the quality management program required by 10 CFR 35.32 that results in a misadministration;

4. A failure to establish, implement, or maintain all criticality controls (or control systems) for a single nuclear criticality scenario when a critical mass of fissile material was present or reasonably available, such that a nuclear criticality

accident was possible; or

5. The potential for a significant injury or loss of life due to a loss of control over licensed or certified activities, including chemical processes that are integral to the licensed or certified activity, whether radioactive material is released or not (e.g., movement of liquid UF₆ cylinder by unapproved methods).

C. Severity Level III - Violations involving for example:

1. A failure to control access to licensed materials for radiation protection purposes as specified by NRC requirements;

2. Possession or use of unauthorized equipment or materials in the conduct of licensee activities which degrades safety;

3. Use of radioactive material on humans where such use is not authorized;

4. Conduct of licensed activities by a technically unqualified or uncertified person;

5. A substantial potential for exposures, radiation levels, contamination levels, or releases, including releases of toxic material caused by a failure to comply with NRC regulations, from licensed or certified activities in excess of regulatory limits;

6. Substantial failure to implement the quality management program as required by 10 CFR 35.32 that does not result in a misadministration; failure to report a misadministration; or programmatic weakness in the implementation of the quality management program that results in a misadministration;

7. A breakdown in the control of licensed activities involving a number of violations that are related (or, if isolated, that are recurring violations) that collectively represent a potentially significant lack of attention or carelessness toward licensed responsibilities;

8. A failure, during radiographic

operations, to have present at least two qualified individuals or to use radiographic equipment, radiation survey instruments, and/or personnel monitoring devices as required by 10 CFR Part 34;

9. A failure to submit an NRC Form 241 as required by 10 CFR 150.20;

10. A failure to receive required NRC approval prior to the implementation of a change in licensed activities that has radiological or programmatic significance, such as, a change in ownership; lack of an RSO or replacement of an RSO with an unqualified individual; a change in the location where licensed activities are being conducted, or where licensed material is being stored where the new facilities do not meet safety guidelines; or a change in the quantity or type of radioactive material being processed or used that has radiological significance;

11. A significant failure to meet decommissioning requirements including a failure to notify the NRC as required by regulation or license condition, substantial failure to meet decommissioning standards, failure to conduct and/or complete decommissioning activities in accordance with regulation or license condition, or failure to meet required schedules without adequate justification;

12. A significant failure to comply with the action statement for a Technical Safety Requirement Limiting Condition for Operation where the appropriate action was not taken within the required time, such as:

(a) In an autoclave, where a containment isolation valve is inoperable for a period in excess of that allowed by the action statement; or

(b) Cranes or other lifting devices engaged in the movement of cylinders having inoperable safety components, such as redundant braking systems, or other safety devices for a period in excess of that allowed by the action statement;

13. A system designed to prevent or

mitigate a serious safety event:

(a) Not being able to perform its intended function under certain conditions (e.g., safety system not operable unless utilities available, materials or components not according to specifications); or

(b) Being degraded to the extent that a detailed evaluation would be required to determine its operability;

14. Changes in parameters that cause unanticipated reductions in margins of safety;

15. A significant failure to meet the requirements of 10 CFR 76.68, including a failure such that a required certificate amendment was not sought;

16. A failure of the certificate holder to conduct adequate oversight of vendors or contractors resulting in the use of products or services that are of defective or indeterminate quality and that have safety significance;

17. Equipment failures caused by inadequate or improper maintenance that substantially complicates recovery from a plant transient;

18. A failure to establish, maintain, or implement all but one criticality control (or control systems) for a single nuclear criticality scenario when a critical mass of fissile material was present or reasonably available, such that a nuclear criticality accident was possible; or

19. A failure, during radiographic operations, to stop work after a pocket dosimeter is found to have gone off-scale, or after an electronic dosimeter reads greater than 200 mrem, and before a determination is made of the individual's actual radiation exposure.

D. Severity Level IV - Violations involving for example:

1. A failure to maintain patients hospitalized who have cobalt-60, cesium-137, or iridium-192 implants or to conduct required leakage or contamination tests, or to use properly calibrated equipment;

2. Other violations that have more than minor safety or environmental significance;

3. Failure to follow the quality management (QM) program, including

procedures, whether or not a misadministration occurs, provided the failures are isolated, do not demonstrate a programmatic weakness in the implementation of the QM program, and have limited consequences if a misadministration is involved; failure to conduct the required program review; or failure to take corrective actions as required by 10 CFR 35.32;

4. A failure to keep the records required by 10 CFR 35.32 or 35.33;

5. A less significant failure to comply with the Action Statement for a Technical Safety Requirement Limiting Condition for Operation when the appropriate action was not taken within the required time;

6. A failure to meet the requirements of 10 CFR 76.68 that does not result in a Severity Level I, II, or III violation;

7. A failure to make a required written event report, as required by 10 CFR 76.120(d)(2); or

8. A failure to establish, implement, or maintain a criticality control (or control system) for a single nuclear criticality scenario when the amount of fissile material available was not, but could have been sufficient to result in a nuclear criticality.

SUPPLEMENT VII—MISCELLANEOUS MATTERS

This supplement provides examples of violations in each of the four severity levels as guidance in determining the appropriate severity level for violations involving miscellaneous matters.

A. Severity Level I - Violations involving for example:

1. Inaccurate or incomplete information²¹ that is provided to the

²¹ In applying the examples in this supplement regarding inaccurate or incomplete information and records, reference should also be made to the guidance in Section IX, "Inaccurate and Incomplete Information," and to the

NRC (a) deliberately with the knowledge of a licensee official that the information is incomplete or inaccurate, or (b) if the information, had it been complete and accurate at the time provided, likely would have resulted in regulatory action such as an immediate order required by the public health and safety;

2. Incomplete or inaccurate information that the NRC requires be kept by a licensee that is (a) incomplete or inaccurate because of falsification by or with the knowledge of a licensee official, or (b) if the information, had it been complete and accurate when reviewed by the NRC, likely would have resulted in regulatory action such as an immediate order required by public health and safety considerations;

3. Information that the licensee has identified as having significant implications for public health and safety or the common defense and security ("significant information identified by a licensee") and is deliberately withheld from the Commission;

4. Action by senior corporate management in violation of 10 CFR 50.7 or similar regulations against an employee;

5. A knowing and intentional failure to provide the notice required by 10 CFR Part 21; or

6. A failure to substantially implement the required fitness-for-duty program.²²

B. Severity Level II - Violations involving for example:

1. Inaccurate or incomplete information that is provided to the NRC (a) by a licensee official because of careless disregard for the completeness or accuracy of the information, or (b) if the information, had it been complete

and accurate at the time provided, likely would have resulted in regulatory action such as a show cause order or a different regulatory position;

2. Incomplete or inaccurate information that the NRC requires be kept by a licensee which is (a) incomplete or inaccurate because of careless disregard for the accuracy of the information on the part of a licensee official, or (b) if the information, had it been complete and accurate when reviewed by the NRC, likely would have resulted in regulatory action such as a show cause order or a different regulatory position;

3. "Significant information identified by a licensee" and not provided to the Commission because of careless disregard on the part of a licensee official;

4. An action by plant management above first-line supervision in violation of 10 CFR 50.7 or similar regulations against an employee;

5. A failure to provide the notice required by 10 CFR Part 21;

6. A failure to remove an individual from unescorted access who has been involved in the sale, use, or possession of illegal drugs within the protected area or take action for on duty misuse of alcohol, prescription drugs, or over-the-counter drugs;

7. A failure to take reasonable action when observed behavior within the protected area or credible information concerning activities within the protected area indicates possible unfitness for duty based on drug or alcohol use;

8. A deliberate failure of the licensee's Employee Assistance Program (EAP) to notify licensee's management when EAP's staff is aware that an individual's condition may adversely affect safety related activities; or

9. The failure of licensee management to take effective action in correcting a hostile work environment.

C. Severity Level III - Violations involving for example:

1. Incomplete or inaccurate information that is provided to the NRC (a) because of inadequate actions on the part of licensee officials but not amounting to a Severity

Level I or II violation, or (b) if the information, had it been complete and accurate at the time provided, likely would have resulted in a reconsideration of a regulatory position or substantial further inquiry such as an additional inspection or a formal request for information;

2. Incomplete or inaccurate information that the NRC requires be kept by a licensee that is (a) incomplete or inaccurate because of inadequate actions on the part of licensee officials but not amounting to a Severity Level I or II violation, or (b) if the

information, had it been complete and accurate when reviewed by the NRC, likely would have resulted in a reconsideration of a regulatory position or substantial further inquiry such as an additional inspection or a formal request for information;

3. A failure to provide "significant information identified by a licensee" to the Commission and not amounting to a Severity Level I or II violation;

4. An action by first-line supervision in violation of 10 CFR 50.7 or similar regulations against an employee;

5. An inadequate review or failure to review such that, if an appropriate review had been made as required, a 10 CFR Part 21 report would have been made;

6. A failure to complete a suitable inquiry on the basis of 10 CFR Part 26, keep records concerning the denial of access, or respond to inquiries concerning denials of access so that, as a result of the failure, a person previously denied access for fitness-for-duty reasons was improperly granted access;

7. A failure to take the required action for a person confirmed to have been tested positive for illegal drug use or take action for onsite alcohol use; not amounting to a Severity Level II violation;

8. A failure to assure, as required, that contractors or vendors have an effective fitness-for-duty program;

definition of "licensee official" contained in Section IV.C.

²² The example for violations for fitness-for-duty relate to violations of 10 CFR Part 26.

9. A breakdown in the fitness-for-duty program involving a number of violations of the basic elements of the fitness-for-duty program that collectively reflect a significant lack of attention or carelessness towards meeting the objectives of 10 CFR 26.10; or

10. Threats of discrimination or restrictive agreements which are violations under NRC regulations such as 10 CFR 50.7(f).

D. Severity Level IV - Violations involving for example:

1. Incomplete or inaccurate information of more than minor significance that is provided to the NRC but not amounting to a Severity Level I, II, or III violation;

2. Information that the NRC requires be kept by a licensee and that is incomplete or inaccurate and of more than minor significance but not amounting to a Severity Level I, II, or III violation;

3. An inadequate review or failure to review under 10 CFR Part 21 or other procedural violations associated with 10 CFR Part 21 with more than minor safety significance;

4. Violations of the requirements of Part 26 of more than minor significance;

5. A failure to report acts of licensed operators or supervisors pursuant to 10 CFR 26.73; or

6. Discrimination cases which, in themselves, do not warrant a Severity Level III categorization.

SUPPLEMENT VIII--EMERGENCY PREPAREDNESS

This supplement provides examples of violations in each of the four severity levels as guidance in determining the appropriate severity level for violations in the area of emergency preparedness. It should be noted that citations are not normally made for violations involving emergency preparedness occurring during emergency exercises. However, where exercises reveal (i) training, procedural, or repetitive failures for which corrective actions have not been

taken, (ii) an overall concern regarding the licensee's ability to implement its plan in a manner that adequately protects public health and safety, or (iii) poor self critiques of the licensee's exercises, enforcement action may be appropriate.

A. Severity Level I - Violations involving for example:

In a general emergency, licensee failure to promptly (1) correctly classify the event, (2) make required notifications to responsible Federal, State, and local agencies, or (3) respond to the event (e.g., assess actual or potential offsite consequences, activate emergency response facilities, and augment shift staff.)

B. Severity Level II - Violations involving for example:

1. In a site emergency, licensee failure to promptly (1) correctly classify the event, (2) make required notifications to responsible Federal, State, and local agencies, or (3) respond to the event (e.g., assess actual or potential offsite consequences, activate emergency response facilities, and augment shift staff); or

2. A licensee failure to meet or implement more than one emergency planning standard involving assessment or notification.

C. Severity Level III - Violations involving for example:

1. In an alert, licensee failure to promptly (1) correctly classify the event, (2) make required notifications to responsible Federal, State, and local agencies, or (3) respond to the event (e.g., assess actual or potential offsite consequences, activate emergency response facilities, and augment shift staff);

2. A licensee failure to meet or implement one emergency planning standard involving assessment or notification; or

3. A breakdown in the control of licensed activities involving a number of violations that are related (or, if isolated, that are recurring violations) that collectively represent a potentially significant lack of attention or carelessness toward licensed responsibilities.

D. Severity Level IV - Violations

involving for example:

A licensee failure to meet or implement any emergency planning standard or requirement not directly related to assessment and notification.

ENCLOSURE 3
UNITED STATES NUCLEAR REGULATORY COMMISSION
RULES and REGULATIONS

TITLE 10, CHAPTER 1, CODE OF FEDERAL REGULATIONS—ENERGY

**PART
50**

**DOMESTIC LICENSING OF PRODUCTION
AND UTILIZATION FACILITIES**

GENERAL PROVISIONS

- Sec.
50.1 Basis, purpose, and procedures applicable.
50.2 Definitions.
50.3 Interpretations.
50.4 Written communications.
50.5 Deliberate misconduct.
50.7 Employee protection.
50.8 Information collection requirements: OMB approval.
50.9 Completeness and accuracy of information.

REQUIREMENT OF LICENSE, EXCEPTIONS

- 50.10 License required.
50.11 Exceptions and exemptions from licensing requirements.
50.12 Specific exemptions.
50.13 Attacks and destructive acts by enemies of the United States; and defense activities.

**CLASSIFICATION AND DESCRIPTION OF
LICENSES**

- 50.20 Two classes of licenses.
50.21 Class 104 licenses; for medical therapy and research and development facilities.
50.22 Class 103 licenses; for commercial and industrial facilities.
50.23 Construction permits.

APPLICATIONS FOR LICENSES, FORM, CONTENTS, INELIGIBILITY OF CERTAIN APPLICANTS

- 50.30 Filing of applications for licenses: oath or affirmation.
50.31 Combining applications.
50.32 Elimination of repetition.
50.33 Contents of applications; general information.
50.33a Information requested by the Attorney General for antitrust review.
50.34 Contents of applications; technical information.
50.34a Design objectives for equipment to control releases of radioactive material in effluents—nuclear power reactors.

- 50.35 Issuance of construction permits.
50.36 Technical specifications.
50.36a Technical specifications on effluents from nuclear power reactors.
50.36b Environmental conditions.
50.37 Agreement limiting access to Classified Information.
50.38 Ineligibility of certain applicants.
50.39 Public inspection of applications.

**STANDARDS FOR LICENSES AND
CONSTRUCTION PERMITS**

- 50.40 Common standards.
50.41 Additional standards for class 104 licenses.
50.42 Additional standards for class 103 licenses.
50.43 Additional standards and provisions affecting class 103 licenses for commercial power.
50.44 Standards for combustible gas control systems in light-water-cooled power reactors.
50.45 Standards for construction permits.
50.46 Acceptance criteria for emergency core cooling systems for light-water nuclear power reactors.
50.47 Emergency plans.
50.48 Fire protection.
50.49 Environmental qualification of electric equipment important to safety for nuclear power plants.

**ISSUANCE, LIMITATIONS, AND CONDITIONS
OF LICENSES AND CONSTRUCTION PERMITS**

- 50.50 Issuance of licenses and construction permits.
50.51 Continuation of license.
50.52 Combining licenses.
50.53 Jurisdictional limitations.
50.54 Conditions of licenses.
50.55 Conditions of construction permits.
50.55a Codes and standards.
50.56 Conversion of construction permit to license; or amendment of license.
50.57 Issuance of operating license.
50.58 Hearings and report of the Advisory Committee on Reactor Safeguards.

- 50.59 Changes, tests and experiments.
50.60 Acceptance criteria for fracture prevention measures for light-water nuclear power reactors for normal operation.
50.61 Fracture toughness requirements for protection against pressurized thermal shock events.
50.62 Requirements for reduction of risk from anticipated transients without scram (ATWS) events for light-water-cooled nuclear power plants.
50.63 Loss of all alternating current power.
50.64 Limitations on the use of highly enriched uranium (HEU) in domestic non-power reactors.
50.65 Requirements for monitoring the effectiveness of maintenance at nuclear power plants.
50.66 Requirements for thermal annealing of the reactor pressure vessel.

**INSPECTIONS, RECORDS, REPORTS,
NOTIFICATIONS**

- 50.70 Inspections.
50.71 Maintenance of records, making of reports.
50.72 Immediate notification requirements for operating nuclear power reactors.
50.73 Licensee event report system.
50.74 Notification of change in operator or senior operator status.
50.75 Reporting and recordkeeping for decommissioning planning.

US/IAEA SAFEGUARDS AGREEMENT

- 50.78 Installation information and verification.

**TRANSFERS OF LICENSES—CREDITORS'
RIGHTS—SURRENDER OF LICENSES**

- 50.80 Transfer of licenses.
50.81 Creditor regulations.
50.82 Termination of license.

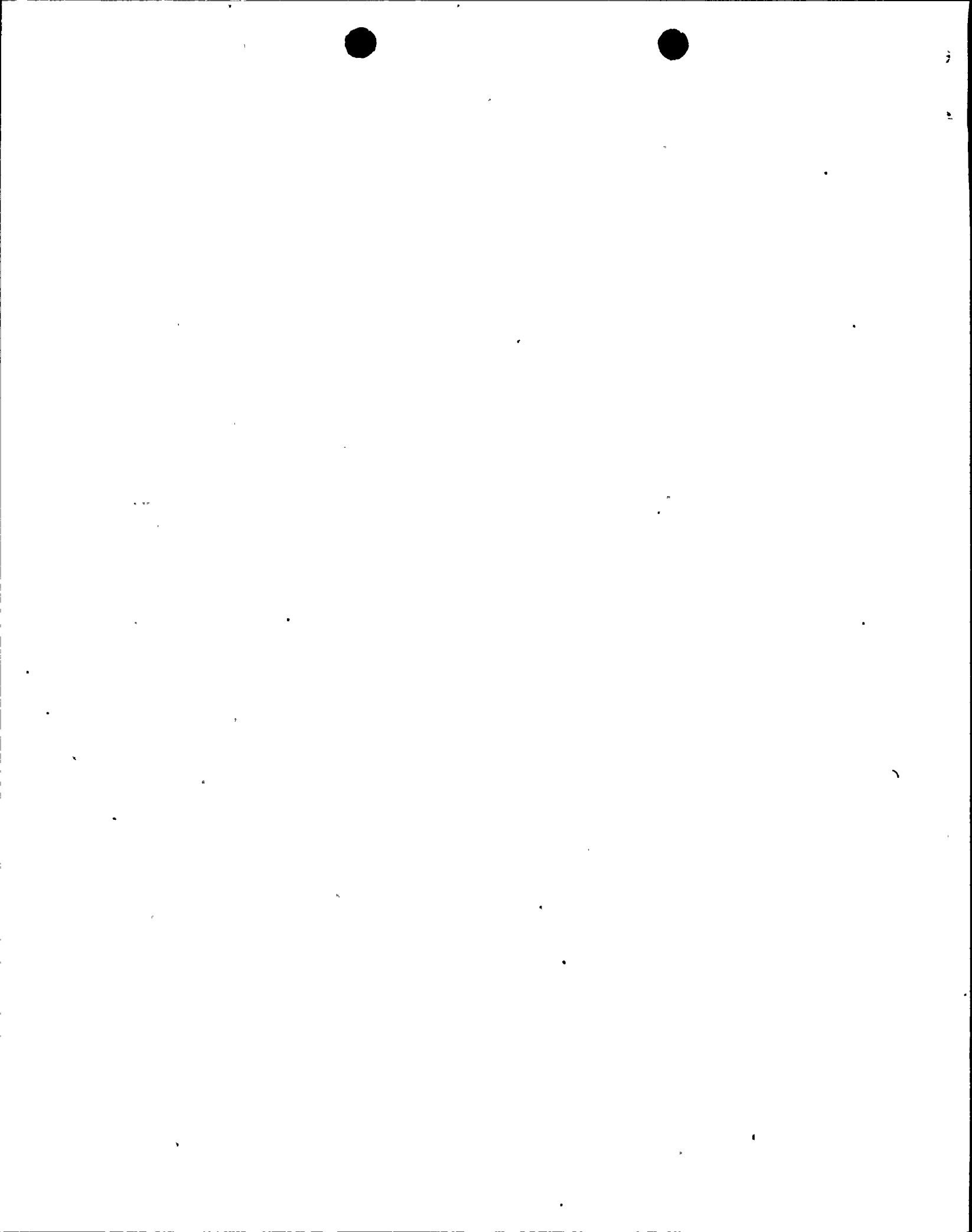

(d) Delivery of communications.

Written communications may be delivered to the Document Control Desk at 11555 Rockville Pike, Rockville, Maryland between the hours of 8:15 a.m. and 4:00 p.m. Eastern Time. If a submittal due date falls on Saturday, Sunday, or Federal holiday, the next Federal working day becomes the official due date.

(e) Regulation governing submission.

Licenses and applicants submitting correspondence, reports, and other written communications pursuant to the regulations of this part are requested but not required to cite whenever practical, in the upper right corner of the first page of the submittal, the specific regulation or other basis, requiring submission.

(f) Conflicting requirements.

The communications requirements contained in this section and §§ 50.12, 50.30, 50.36, 50.36a, 50.44, 50.49, 50.54, 50.55, 50.55a, 50.59, 50.62, 50.71, 50.73, 50.82, 50.90, and 50.91 supersede and replace all existing requirements in any license conditions or technical specifications in effect on January 5, 1987. Exceptions to these requirements must be approved by the Information and Records Management Branch, Nuclear Regulatory Commission, Washington, DC 20555, Telephone (301) 415-7230.

§ 50.5 Deliberate misconduct.

(a) Any licensee or any employee of a licensee; and any contractor (including a supplier or consultant), subcontractor, or any employee of a contractor or subcontractor, of any licensee, who knowingly provides to any licensee, contractor, or subcontractor, components, equipment, materials, or other goods or services, that relate to a licensee's activities subject to this part; may not:

(1) Engage in deliberate misconduct that causes or, but for detection, would have caused, a licensee to be in violation of any rule, regulation, or order, or any term, condition, or limitation of any license, issued by the Commission, or

(2) Deliberately submit to the NRC, a licensee, or a licensee's contractor or subcontractor, information that the person submitting the information knows to be incomplete or inaccurate in some respect material to the NRC.

(b) A person who violates paragraph (a)(1) or (a)(2) of this section may be subject to enforcement action in accordance with the procedures in 10 CFR part 2, subpart B.

(c) For purposes of paragraph (a)(1) of this section, deliberate misconduct by a person means an intentional act or omission that the person knows:

(1) Would cause a licensee to be in violation of any rule, regulation, or order, or any term, condition, or limitation, of any license issued by the Commission, or

(2) Constitutes a violation of a requirement, procedure, instruction, contract, purchase order or policy of a licensee, contractor, or subcontractor.

§ 50.7 Employee protection.

(a) Discrimination by a Commission licensee, an applicant for a Commission license, or a contractor or subcontractor of a Commission licensee or applicant against an employee for engaging in certain protected activities is prohibited. Discrimination includes discharge and other actions that relate to compensation, terms, conditions, or privileges of employment. The protected activities are established in section 211 of the Energy Reorganization Act of 1974, as amended, and in general are related to the administration or enforcement of a requirement imposed under the Atomic Energy Act or the Energy Reorganization Act.

(1) The protected activities include but are not limited to:

(i) Providing the Commission or his or her employer information about alleged violations of either of the statutes named in paragraph (a) introductory text of the section or possible violations of requirements imposed under either of those statutes;

(ii) Refusing to engage in any practice made unlawful under either of the statutes named in paragraph (a) introductory text or under these requirements if the employee has identified the alleged illegality to the employer;

(iii) Requesting the Commission to institute action against his or her employer for the administration or enforcement of these requirements;

(iv) Testifying in any Commission proceeding, or before Congress, or at any Federal or State proceeding regarding any provision (or proposed provision) of either of the statutes named in paragraph (a) introductory text.

(v) Assisting or participating in, or is about to assist or participate in, these activities.



**UNITED STATES NUCLEAR REGULATORY COMMISSION
RULES and REGULATIONS**

TITLE 10, CHAPTER 1, CODE OF FEDERAL REGULATIONS—ENERGY

26.2(a)

**PART
26**

FITNESS-FOR-DUTY PROGRAM

General Provisions**Sec.**

- 26.1 Purpose.
- 26.2 Scope.
- 26.3 Definitions.
- 26.4 Interpretations.
- 26.6 Exemptions.
- 26.8 Information collection requirements: OMB approval.

General Performance Objectives

- 26.10 General performance objectives.

Program Elements and Procedures

- 26.20 Written policy and procedures.
- 26.21 Policy communications and awareness training.
- 26.22 Training of supervisors and escorts.
- 26.23 Contractors and vendors.
- 26.24 Chemical and alcohol testing.
- 26.25 Employee assistance programs (EAP).
- 26.27 Management actions and sanctions to be imposed.
- 26.28 Appeals.
- 26.29 Protection of information.

Inspections, Records and Reports

- 26.70 Inspections.
- 26.71 Recordkeeping requirements.
- 26.73 Reporting requirements.

Audits

- 26.80 Audits.

Enforcement

- 26.90 Violations.
- 26.91 Criminal penalties.

**Appendix A to Part 26—Guidelines for
Drug and Alcohol Testing Programs**

Subpart A—General

- 1.1 Applicability
- 1.2 Definitions

Subpart B—Scientific and Technical Requirements

- 2.1 The Substances
- 2.2 General Administration of Testing
- 2.3 Preventing Subversion of Testing
- 2.4 Specimen Collection Procedures
- 2.5 HHS-Certified Laboratory Personnel
- 2.6 Licensee Testing Facility Personnel
- 2.7 Laboratory and Testing Facility Analysis Procedures
- 2.8 Quality Assurance and Quality Control
- 2.9 Reporting and Review of Results

Subpart C—Employee Protection

- 3.1 Protection of Employee Records
- 3.2 Individual Access to Test and Laboratory Certification Results

Subpart D—Certification of Laboratories Engaged in Chemical Testing

- 4.1 Use of DHHS-Certified Laboratories

Authority: Secs. 53, 81, 103, 104, 107, 161, 68 Stat. 930, 935, 936, 937, 948, as amended, sec. 1701, 106 Stat. 2951, 2952, 2953 (42 U.S.C. 2073, 2111, 2112, 2133, 2134, 2137, 2201, 2297f); secs. 201, 202, 206, 88 Stat. 1242, 1244, 1246, as amended (42 U.S.C. 5841, 5842, 5846).

General Provisions**§ 26.1 Purpose.**

This part prescribes requirements and standards for the establishment and maintenance of certain aspects of fitness-for-duty programs and procedures by the licensed nuclear power industry, and by licensees authorized to possess, use, or transport formula quantities of strategic special nuclear material (SSNM).

§ 26.2 Scope.

(a) The regulations in this part apply to licensees authorized to operate a nuclear power reactor, to possess or use formula quantities of SSNM, or to transport formula quantities of SSNM. Each licensee shall implement a fitness-for-duty program which complies with this part. The provisions of the fitness-for-duty program must apply to all persons granted unescorted access to nuclear power plant protected areas, to licensee, vendor, or contractor personnel required to physically report to a licensee's Technical Support Center (TSC) or Emergency Operations Facility (EOF) in accordance with licensee emergency plans and procedures, and to SSNM licensee and transporter personnel who:

- (1) Are granted unescorted access to Category IA Material;
- (2) Create or have access to procedures or records for safeguarding SSNM;
- (3) Make measurements of Category IA Material;
- (4) Transport or escort Category IA Material; or
- (5) Guard Category IA Material.



§ 26.24 Chemical and alcohol testing.

58 FR 31467

(a) To provide a means to deter and detect substance abuse, the licensee shall implement the following chemical testing programs for persons subject to this Part:

54 FR 24468

(1) Testing within 60 days prior to the initial granting of unescorted access to protected areas or assignment to activities within the scope of this Part.

(2) Unannounced drug and alcohol tests imposed in a statistically random and unpredictable manner so that all persons in the population subject to testing have an equal probability of being selected and tested. The tests must be administered so that a person completing a test is immediately eligible for another unannounced test. As a minimum, tests must be administered on a nominal weekly frequency and at various times during the day. Random testing must be conducted at an annual rate equal to at least 50 percent of the workforce.

59 FR 502

(3) Testing for-cause, i.e., as soon as possible following any observed behavior indicating possible substance abuse; after accidents involving a failure in individual performance resulting in personal injury, in a radiation exposure or release of radioactivity in excess of regulatory limits, or actual or potential substantial degradations of the level of safety of the plant if there is reasonable suspicion that the worker's behavior contributed to the event; or after receiving credible information that an individual is abusing drugs or alcohol.

54 FR 24468

(4) Follow-up testing on an unannounced basis to verify continued abstention from the use of substances covered under this Part.

(b) Testing for drugs and alcohol, at a minimum, must conform to the "Guidelines for Drug and Alcohol Testing Programs," issued by the Nuclear Regulatory Commission and appearing in appendix A to this part, hereinafter referred to as the NRC Guidelines. Licensees, at their discretion, may implement programs with more stringent standards (e.g., lower cutoff levels, broader panel of drugs). All requirements in this part still apply to persons who fall a more stringent standard, but do not test positive under the NRC Guidelines. Management actions must be the same with the more stringent standards as if the individual had failed the NRC standards.

58 FR 31467

(c) Licensees shall test for all substances described in paragraph 2.1(a) of the NRC Guidelines. In addition, licensees may consult with local law enforcement authorities, hospitals, and drug counseling services to determine whether other substances with abuse potential are being used in the geographical locale of the facility and the local workforce. When appropriate, other substances so identified may be added to the panel of substances for testing. Appropriate cutoff limits must be established by the licensee for these substances.

54 FR 24468

(d)(1) Licensees may conduct initial screening tests of an aliquot before forwarding selected specimens to a laboratory certified by the Department of Health and Human Services (HHS), provided the licensee's staff possesses the necessary training and skills for the tasks assigned, the staff's qualifications are documented, and adequate quality controls for the testing are implemented. Quality control procedures for initial screening tests by a licensee's testing facility must include the processing of blind performance test specimens and the submission to the HHS-certified laboratory of a sampling of specimens initially tested as negative. Except for the purposes discussed below, access to the results of preliminary tests must be limited to the licensee's testing staff, the Medical Review Officer (MRO), the Fitness-for-Duty Program Manager, and the employee assistance program staff, when appropriate.

56 FR 41922

(2) No individual may be removed or temporarily suspended from unescorted access or be subjected to other administrative action based solely on an unconfirmed positive result from any drug test, other than for marijuana (THC) or cocaine, unless other evidence indicates that the individual is impaired or might otherwise pose a safety hazard. With respect to onsite initial screening tests for marijuana (THC) and cocaine, licensee management may be informed and licensees may temporarily suspend individuals from unescorted access or from normal duties or take lesser administrative actions against the individual based on an unconfirmed presumptive positive result provided the licensee complies with the following conditions:

56 FR 41922

(i) For the drug for which action will be taken, at least 85 percent of the specimens which were determined to be presumptively positive as a result of preliminary onsite screening tests during the last 6-month data reporting period submitted to the Commission under § 26.71(d) were subsequently reported as positive by the HHS-certified laboratory as the result of a GC/MS confirmatory test.

(ii) There is no loss of compensation or benefits to the tested person during the period of temporary administrative action.

(iii) Immediately upon receipt of a negative report from the HHS-certified laboratory, any matter which could link the individual to a temporary suspension is eliminated from the tested individual's personnel record or other records.



1
2
3