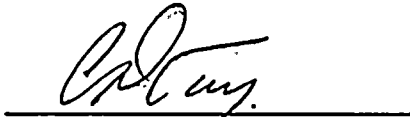

NINE MILE POINT NUCLEAR STATION

NINE MILE POINT UNIT 1

OFF-SITE DOSE CALCULATION MANUAL (ODCM)

<u>APPROVALS</u>	<u>SIGNATURES</u>	<u>DATE</u>
N. L. Rademacher Plant Manager Unit 1		<u>6/25/96</u>
C. D. Terry V.P. Nuclear Engineering		<u>6/25/96</u>

NIAGARA MOHAWK POWER CORPORATION

9609090353 960828
PDR ADOCK 05000220
R PDR



SUMMARY OF REVISIONS

Revision 17 (Effective 6/30/96)

<u>PAGE</u>	<u>DATE</u>
1, 2, 5, 6, 8, 9, 11-13/15-18, 21, 24, 25, 36-44, 47-49, 52-81, 86-116	February 1987
3, 4, 7, 10, 14, 19, 20, 22, 23, 26-35	December 1987
45, 46, 50, 51, 82-85	January 1988
*29	May 1988 (Reissue)
*64, 77, 78	May 27, 1988 (Reissue)
i, 19, 21, 22A, 22B, 124, 25, 26, 112 i, ii, iii, 12-16, 18, 28-40, 45-47	February 1990
52, 55, 59-89, 92, 93, 97-129	June 1990
91-93, 95	June 1992
3, 4, 21, 92, 95a-c	February 1993
10, 16-20	March 1993
5, 13, 18, 20, 25-30, 65, 79	June 1993
66, 69	December 1993
16, 69	June 1994
10, 12	February 1995
10, 18, 67, 69	December 1995
5, D-1	June 1996

12

13



14

ODCM - NINE MILE POINT UNIT 1

TABLE OF CONTENTS

	<u>PAGE</u>
1.0 INTRODUCTION	1
2.0 LIQUID EFFLUENTS	2
2.1 Setpoint Determinations	2
2.1.1 Basis	2
2.1.2 Service Water System Effluent Alarm Setpoint	2
2.1.3 Liquid Radwaste Effluent Alarm Setpoint	3
2.1.4 Discussion	4
2.1.4.1 Control of Liquid Effluent Batch Discharges	4
2.1.4.2 Simultaneous Discharges of Radioactive Liquids	4
2.1.4.3 Sample Representativeness	5
2.1.4.4 Liquid Radwaste System Operation	5
2.1.4.5 Service Water System Contamination	6
2.2 Liquid Effluent Concentration Calculation	6
2.3 Dose Determinations	7
2.3.1 Maximum Dose Equivalent Pathway	7
3.0 GASEOUS EFFLUENTS	10
3.1 Setpoint Determinations	10
3.1.1 Basis	10
3.1.2 Stack Monitor Setpoints	10
3.1.3 Recombiner Discharge (Off Gas) Monitor Setpoints	12
3.1.4 Emergency Condenser Vent Monitor Setpoint	13



ODCM - NINE MILE POINT UNIT 1

TABLE OF CONTENTS (Cont)

	<u>PAGE</u>
3.1.5 Discussion	13
3.1.5.1 Stack Effluent Monitoring System Description	13
3.1.5.2 Stack Sample Flow Path - RAGEMS	13
3.1.5.3 Stack Sample Flow Path - OGESMS	14
3.1.5.4 Sample Frequency/Sample Analysis	14
3.1.5.5 I-133 Estimates	14
3.1.5.6 Gaseous Radwaste Treatment System Operation	15
3.2 Dose and Dose Rate Determination	15
3.2.1 Dose Rate	16
3.2.1.1 Noble Gases	16
3.2.1.2 Tritium, Iodines and Particulates	18
3.2.2 Dose	19
3.2.2.1 Noble Gas Air Dose	19
3.2.2.2 Tritium Iodines and Particulates	20
3.2.2.3 Accumulating Doses	21
3.3 Critical Receptors	21
3.4 Refinement of Offsite Doses Resulting From Emergency Condenser Vent Releases	22
4.0 40 CFR 190 REQUIREMENTS	23
4.1 Evaluation of Doses From Liquid Effluents	24
4.2 Evaluation of Doses From Gaseous Effluents	25
4.3 Evaluation of Doses From Direct Radiation	26

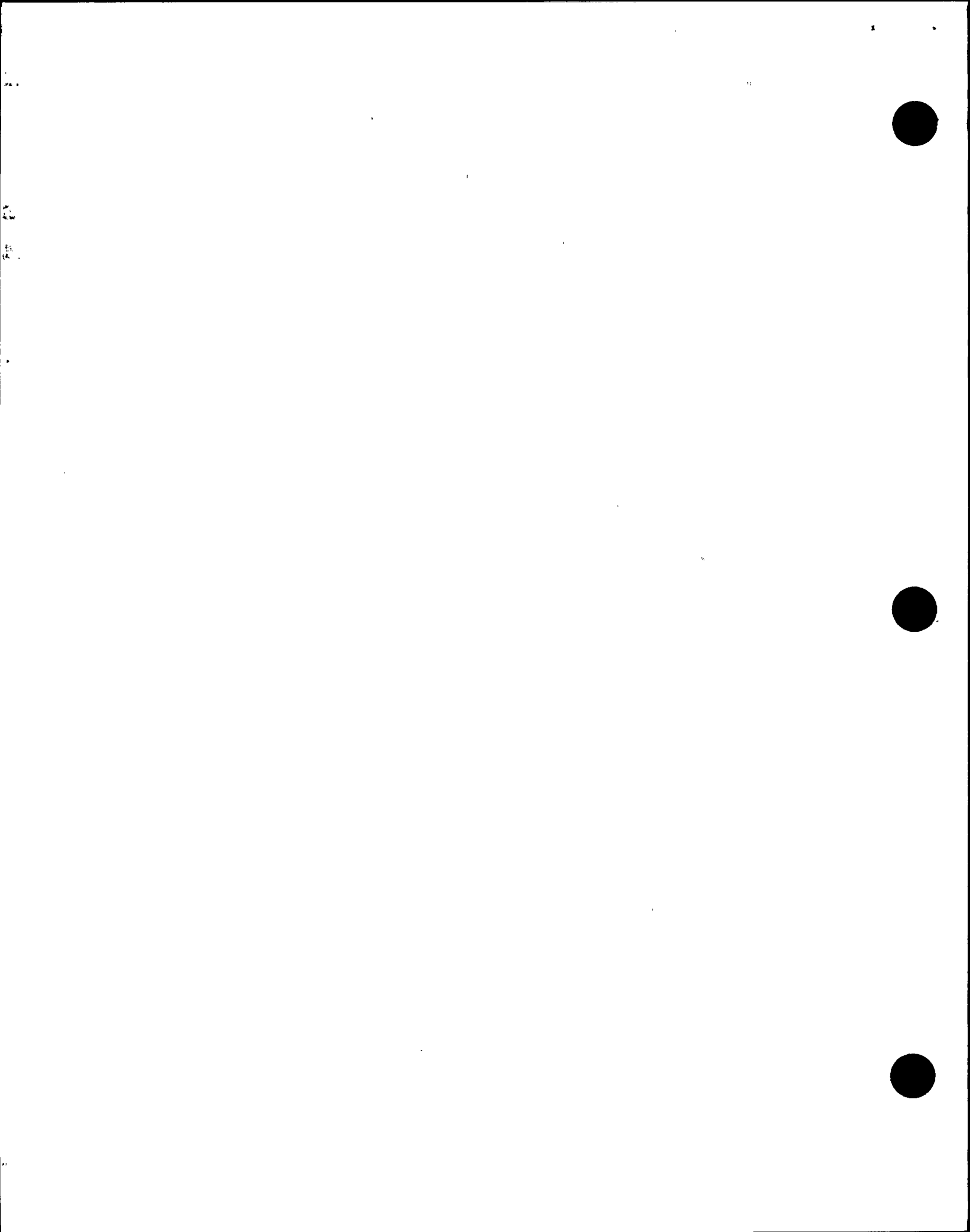

ODCM - NINE MILE POINT UNIT 1

TABLE OF CONTENTS (Cont)

	<u>PAGE</u>
4.4	Doses to Members of the Public Within the Site Boundary 26
5.0	ENVIRONMENTAL MONITORING PROGRAM 29
5.1	Sampling Stations 29
5.2	Interlaboratory Comparison Program 29
5.3	Capabilities for Thermoluminescent Dosimeters Used for Environmental Measurements 30
Table 1-1	Average Energy Per Disintegration 32
Tables 2-1 to 2-8	A_{int} Values for the NMP-1 Facility 33
Table 3-1	Critical Receptor Dispersion Parameters for Ground Level and Elevated Releases 41
Table 3-2	Gamma Air and Whole Body Plume Shine Dose Factors for Noble Gases (B_i and V_i) 42
Table 3-3	Immersion Dose Factors for Noble Gases 43
Tables 3-4 to 3-22	Organ Dose and Dose Rate Factors (R_i) 44
Table 3-23	Parameters for the Evaluation of Doses to Real Members of the Public from Gaseous and Liquid Effluents 63
Table 5.1	NMP-1 Radiological Environmental Monitoring Program Sampling Locations 64
Figure 5.1-1	Nine Mile Point On-Site Map 68
Figure 5.1-2	Nine Mile Point Offsite Map 69
Figure 5.1.3-1	Site Boundaries 70
Appendix A	Liquid Dose Factor Derivation (A_{int}) 71
Appendix B	Plume Shine Dose Factor Derivation (B_i and V_i) 74
Appendix C	Organ Dose and Dose Rate Factors for Iodine - 131 & 133, Particulates and Tritium (R_i) 78
Appendix D	Diagrams of Liquid and Gaseous Radwaste Treatment Systems . . 88



1.0 INTRODUCTION

The Offsite Dose Calculation Manual (ODCM) provides the methodology to be used for demonstrating compliance with the Radiological Effluent Technical Specifications (RETS), 10 CFR 20, 10 CFR 50, and 40 CFR 190. The contents of the ODCM are based on Draft NUREG-0472, Revision 3, "Standard Radiological Effluent Technical Specifications for Pressurized Water Reactors," September 1982; Draft NUREG-0473, Revision 2, "Radiological Effluent Technical Specifications for BWR's", "July 1979; NUREG 0133, "Preparation of Radiological Effluent Technical Specifications for Nuclear Power Plants," October 1978; the several Regulatory Guides referenced in these documents; and, communication with the NRC staff.

Section 5 contains a detailed description of the Radiological Environmental Monitoring (REM) sampling locations.

Should it be necessary to revise the ODCM, these revisions will be made in accordance with Technical Specifications.



2.0 LIQUID EFFLUENTS

2.1 Setpoint Determinations

2.1.1 Basis

Monitor setpoints will be established such that the concentration of radionuclides in the liquid effluent releases in the discharge canal will not exceed those concentrations as specified in 10 CFR 20, Appendix B, Table II, Column 2. Setpoints for the Service Water System Effluent Line will be calculated quarterly based on the radionuclides identified during the previous year's releases from the liquid radwaste system or the isotopes identified in the most recent radwaste release or other identified probable source. Setpoints for the Liquid Radwaste Effluent Line will be based on the radionuclides identified in each batch of liquid waste prior to its release.

After release, the Liquid Radwaste monitor setpoint may remain as set, or revert back to a setpoint based on a previous Semi-Annual Radioactive Effluent Release Report, or install blank flange in the discharge line and declare inoperable in accordance with the technical specification.

Since the Service Water System effluent monitor and Liquid Radwaste effluent monitor can only detect gamma radiation, the alarm setpoints are calculated by using the concentration of gamma emitting isotopes only (or the corresponding MPC values for the same isotopes, whichever are higher) in the $\sum_i(\mu\text{Ci/ml})_i$ expression (Section 2.1.2, 2.1.3).

The Required Dilution Factor is calculated using concentrations of all isotopes present (or the corresponding MPC values for the same isotopes, whichever are higher) including tritium and other non-gamma emitters to ensure that all radionuclides in the discharge canal do not exceed 10 CFR 20 limits.

2.1.2 Service Water System Effluent Line Alarm Setpoint

The detailed methods for establishing setpoints for the Service Water System Effluent Line Monitor shall be contained in the Nine Mile Point Station Procedures. These methods shall be in accordance with the following:

$$\text{Setpoint (Hi alarm)} = \frac{0.9 \sum_i (\mu\text{Ci/ml})_i (CF) \text{ TDF}/F_{sw}}{\sum_i [(\mu\text{Ci/ml})_i / \text{MPC}_i]} + \text{background}$$

$$\text{Setpoint (Alert alarm)} = \frac{0.7 \sum_i (\mu\text{Ci/ml})_i (CF) \text{ TDF}/F_{sw}}{\sum_i [(\mu\text{Ci/ml})_i / \text{MPC}_i]} + \text{background}$$

$(\mu\text{Ci/ml})_i$ = concentration of gamma emitting isotope i in the sample, or the corresponding MPC of gamma emitting isotope i (MPC_i), whichever is higher (units = $\mu\text{Ci/ml}$).

$(\mu\text{Ci/ml})_T$ = concentration of any radioactive isotope i in the sample including tritium and other non-gamma emitters or corresponding MPC of isotope i , MPC_i , whichever is higher (units = $\mu\text{Ci/ml}$).

TDF = Total Dilution Flow (units = gallons/minutes).

F_{sw} = Service Water Flow (units = gallons/minutes).



2.1.2 Service Water System Effluent Line Alarm Setpoint (Cont'd)

- CF = monitor calibration factor (units = net cpm/ μ Ci/ml).
- MPC_i = liquid effluent radioactivity concentrations limit for radionuclide i as specified in 10 CFR 20, Appendix B, Table II, Column 2.
- Sample = Those nuclides present in the previous batch release from the liquid radwaste effluent system or those nuclides present in the last Semi-annual Radioactive Effluent Release Report (units = μ Ci/ml) or those nuclides present in the service water system.**
- (MPC) _{γ} = same as MPC_i but for gamma emitting nuclides only.
- 0.9 and 0.7 = factors of conservatism to account for inaccuracies.
- $\sum_i [(\mu\text{Ci/ml})_{\pi} / \text{MPC}_i]$ = Required Dilution Factor. If MPC values are used in the $(\mu\text{Ci/ml})_{\gamma}$, they must also be used in calculating RDF (numerator).
- TDF/F_{rw} = Actual Dilution Factor

2.1.3 Liquid Radwaste Effluent Line Alarm Setpoint

The detailed methods for establishing setpoints for the Liquid Radwaste Effluent Line Monitor shall be contained in the Nine Mile Point Station Procedures. These methods shall be in accordance with the following:

$$\text{Setpoint (Hi-Hi alarm)} \leq 0.9 \frac{\sum_i (\mu\text{Ci/ml})_{\gamma} (CF) \text{TDF}/F_{rw}}{\sum_i [(\mu\text{Ci/ml})_{\pi} / \text{MPC}_i]} + \text{background}$$

$$\text{Setpoint (Hi alarm)} \leq 0.7 \frac{\sum_i (\mu\text{Ci/ml})_{\gamma} (CF) \text{TDF}/F_{rw}}{\sum_i [(\mu\text{Ci/ml})_{\pi} / \text{MPC}_i]} + \text{background}$$

$(\mu\text{Ci/ml})_{\gamma}$ = concentration of gamma emitting isotope i in the sample or the corresponding MPC of gamma emitting isotope i, (MPC)_i whichever is higher.

$(\mu\text{Ci/ml})_{\pi}$ = concentration of any radioactive isotope i in the sample including tritium and other non-gamma emitters or the corresponding MPC of isotope i MPC_i whichever is higher. (units = μ Ci/ml).

TDF = Total Dilution Flow (units = gallons/minutes).

F_{rw} = Radwaste Effluent Flow (units = gallons/minutes).

CF = monitor calibration factor (units = net cps/ μ Ci/ml).

** For periods with known reactor water to RCLC system leakage, RCLC maximum permissible concentration may be prudently substituted for the above.



2.1.3 Liquid Radwaste Effluent Line Alarm Setpoint (Cont'd)

- MPC_i = liquid effluent radioactivity concentration limit for radionuclide i as specified in 10 CFR 20, Appendix B, Table II, Column 2, for those nuclides detected by spectral analysis of the contents of the radwaste tanks to be released. (units = $\mu\text{Ci/ml}$)
- $(MPC)_{\gamma}$ = same as MPC_i but for gamma emitting nuclide only.
- 0.9 and 0.7 = factors of conservatism to account for inaccuracies.
- $\Sigma[(\mu\text{Ci/ml})_{\pi}/MPC_i]$ = Required Dilution Factor. If MPC values are used in the $(\mu\text{Ci/ml})_{\gamma}$, they must also be used in calculating RDF (numerator).

Notes: (a) If $TDF/F_{\pi} = \Sigma[(\mu\text{Ci/ml})_{\pi}/MPC_i]$

the discharge could not be made, since the monitor would be continuously in alarm. To avoid this situation, F_{π} will be reduced (normally by a factor of 2) to allow setting the alarm point at a concentration higher than tank concentration. This will also result in a discharge canal concentration at approximately 50% maximum permissible concentration.

(b) The value used for TDF will be reduced by the fractional quantity $(1-FT)$, where FT is tempering fraction (i.e., diversion of some fraction of discharge flow to the intake canal for the purpose of temperature control).

2.1.4 Discussion

2.1.4.1 Control of Liquid Effluent Batch Discharges

At Nine Mile Point Unit 1 Liquid Radwaste Effluents are released only on a batch mode. To prevent the inadvertent release of any liquid radwaste effluents, radwaste discharge is mechanically isolated (blank flange installed or discharge valve chain-locked closed) following the completion of a batch release or series of batch releases.

This mechanical isolation remains in place and will only be removed prior to the next series of liquid radwaste discharges after all analyses required in station procedures and Technical Specification Table 4.6.15-1A are performed and monitor setpoints have been properly adjusted.

2.1.4.2 Simultaneous Discharges of Radioactive Liquids.

If during the discharge of any liquid radwaste batch, there is an indication that the service water canal has become contaminated (through a service water monitor alarm or through a grab sample analysis in the event that the service water monitor is inoperable) the discharge shall be terminated immediately. The liquid radwaste discharge shall not be continued until the cause of the service water alarm (or high grab sample analysis result) has been determined and the appropriate corrective measures taken to ensure 10CFR20, Appendix B, Table II, Column 2 (Technical Specification Section 3.6.15.a(1)) limits are not exceeded.



2.1.4.2 Simultaneous Discharges of Radioactive Liquids (Cont'd)

In accordance with Site Chemistry procedures, controls are in place to preclude a simultaneous release of liquid radwaste batch tanks. In addition, an independent verification of the discharge valve line-up is performed prior to discharge to ensure that simultaneous discharges are prevented.

2.1.4.3 Sampling Representativeness

This section covers Technical Specification Table 4.6.15-1 Note b concerning thoroughly mixing of each batch of liquid radwaste prior to sampling.

Liquid Radwaste Tanks scheduled for discharge at Nine Mile Point Unit 1 are isolated (i.e. inlet valves marked up) and at least two tank volumes of entrained fluids are recirculated prior to sampling. Minimum recirculation time is calculated as follows:

$$\text{Minimum Recirculation Time} = 2.0(T/R)$$

Where:

2.0 = Plant established mixing factor, unitless

T = Tank volume, gal

R = Recirculation flow rate, gpm

Additionally, the Hi Alarm setpoint of the Liquid Radwaste Effluent Radiation Monitor is set at a value corresponding to not more than 70% of its calculated response to the grab sample or corresponding MPC values. Thus, this radiation monitor will alarm if the grab sample, or corresponding MPC value, is significantly lower in activity than any part of the tank contents being discharged.

2.1.4.4 Liquid Radwaste Systems Operation

Technical Specification 3.6.16.a requires that the liquid radwaste system shall be used to reduce the radioactive materials in liquid wastes prior to their discharge, as necessary, to meet the concentration and dose requirements of Technical Specification 3.6.15.

Utilization of the radwaste system will be based on the capability of the indicated components of each process system to process contents of the respective low conductivity and high conductivity collection tanks:

- 1) Low Conductivity (Equipment Drains): Radwaste Filter and Radwaste Demin. (See Fig. D-1) or modular waste water technology ("THERMEX")
- 2) High Conductivity (Floor Drains): Waste Evaporator (See Fig. D-1) or modular waste water technology ("THERMEX") directly to the Waste Sample Tanks.

Cumulative dose contributions from liquid effluents for the current calendar quarter and the current calendar year shall be determined as described in Section 2.3 of this manual prior to the release of each batch of liquid waste. This same dose projection of Section 2.3 will also be performed in the event that untreated liquid waste is discharged, to ensure that the dose limits of Technical Specification 3.6.15.a(2) are not exceeded. (Thereby implementing the requirements of 10CFR50.36a, General Design Criteria 60 of Appendix A and the Design Objective given in Section II-D of Appendix I to 10 CFR50).



2.1.4.4 Liquid Radwaste Systems Operation (Cont'd)

For the purpose of dose projection, the following assumptions shall be made with regard to concentrations of non-gamma emitting radionuclides subsequently analyzed off-site:

- a) [H-3] \leq H-3 Concentration found recent condensate storage tank analysis
- b) [Sr-89] $\leq 4 \times$ Cs-137 Concentration
- c) [Sr-90] $\leq 0.5 \times$ Cs-137 Concentration
- d) [Fe-55] $\leq 1 \times$ Co-60 Concentration

Assumed Scaling Factors used in b, c, and d above represent conservative estimates derived from analysis of historical data from process waste streams. Following receipt of off-site H-3, Sr-89, Sr-90 and Fe-55 analysis information, dose estimates shall be revised using actual radionuclide concentrations and actual tank volumes discharged.

2.1.4.5 Service Water System Contamination

Service water is normally non-radioactive. If contamination is suspected, as indicated by a significant increase in service water effluent monitor response, grab samples will be obtained from the service water discharge lines and a gamma isotopic analysis meeting the LLD requirements of Technical Specification Table 4.6.15-1 completed. If it is determined that an inadvertent radioactive discharge is occurring from the service water system, then:

- a) A 50.59 safety evaluation shall be performed (ref. I&E Bulletin 80-10),
- b) daily service water effluent samples shall be taken and analyzed for principal gamma emitters until the release is terminated,
- c) an incident composite shall be prepared for H-3, gross alpha, Sr-89, Sr-90 and Fe-55 analyses and,
- d) dose projections shall be performed in accordance with Section 2.3 of this manual (using estimated concentrations for H-3, Sr-89, Sr-90 and Fe-55 to be conservatively determined by supervision at the time of the incident).

Additionally, service water effluent monitor setpoints may be recalculated using the actual distribution of isotopes found from sample analysis.

2.2 Liquid Effluent Concentration Calculation

This calculation documents compliance with Technical Specification Section 3.6.1.5.a (1).

The concentration of radioactive material released in liquid effluents to unrestricted areas (see Figure B-7) shall be limited to the concentrations specified in 10CFR20, Appendix B, Table II, Column 2, for radionuclides other than dissolved or entrained noble gases. For dissolved or entrained noble gases, the concentration shall be limited to 2 E-4 microcurie/milliliter ($\mu\text{Ci/ml}$) total activity.



2.2 Liquid Effluent Concentration Calculation (Cont'd)

The concentration of radioactivity from Liquid Radwaste batch releases and, if applicable, Service Water System and emergency condenser start-up vent discharges are included in the calculation. The calculation is performed for a specific period of time. No credit taken for averaging over the calendar year as permitted by 10CFR20.106. The limiting concentration is calculated as follows:

$$\text{MPC Fraction} = \sum_i [(\sum_s C_{i,s} F_s) / (\text{MPC}_i \sum_s F_s)]$$

Where:

MPC Fraction = The limiting concentration of 10 CFR 20, Appendix B, Table II, for radionuclides other than dissolved or entrained noble gases. For noble gases, the concentration shall be limited to 2 E-4 microcurie/ml total activity.

$C_{i,s} (\mu\text{Ci/ml})_s$ = The concentration of nuclide i in particular effluent stream s, $\mu\text{Ci/ml}$.

F_s = The flow rate of a particular effluent stream s, gpm.

MPC_i = The limiting concentration of a specific nuclide i from 10CFR20, Appendix B, Table II, Column 2 (noble gas limit is 2E-4 $\mu\text{Ci/ml}$).

$\sum_s (\mu\text{Ci/ml})_s F_s$ = The total activity rate of nuclide i, in all effluent streams s.

$\sum_s (F_s)$ = The total flow rate of all effluent streams s, gpm (including those streams which do not contain radioactivity).

A value of less than one for MPC fraction is considered acceptable for compliance with Technical Specification Section 3.6.15.a.(1).

2.3 Dose Determination

2.3.1 Maximum Dose Equivalent Pathway

A dose assessment report was prepared for the Nine Mile Point Unit 1 facility by Charles T. Main, Inc., of Boston, MA. This report presented the calculated dose equivalent rates to individuals as well as the population within a 50-mile radius of the facility based on the radionuclides released in liquid and gaseous effluents during the time periods of 1 July 1980 through 31 December 1980 and from January 1981 through 31 December 1981. The radwaste liquid releases are based on a canal discharge rate of 590 ft³/sec which affects near field and far field dilution; therefore, this report is specific to this situation. Utilizing the effluent data contained in the Semi-Annual Radioactive Effluent Release Reports as source terms, dose equivalent rates were determined using the environmental pathway models specified in Regulatory Guides 1.109 and 1.111 as incorporated in the NRC computer codes LADTAP for liquid pathways, and XOQDOQ and GASPARG for gaseous effluent pathways. Dose equivalent rates were calculated for the total body as well as seven organs and/or tissues for the adult, teen, child, and infant age groups. From the standpoint of liquid effluents, the pathways evaluated included fish and drinking water ingestion, and external exposure to water and sediment.

2.3.1

Maximum Dose Equivalent Pathway (Cont'd)

The majority of the dose for a radwaste liquid batch release was received via the fish pathway. However, to comply with Technical Specifications for dose projections, the drinking water and sediment pathways are included. Therefore, all doses due to liquid effluents are calculated monthly for the fish and drinking water ingestion pathways and the sediment external pathway from all detected nuclides in liquid effluents released to the unrestricted areas to each organ. The dose projection for liquid batch releases will also include discharges from the emergency condenser vent as applicable, for all pathways. Each age group dose factor, A_{igt} , is given in Tables 1-1 to 1-8. To expedite time the dose is calculated for a maximum individual instead of each age group. This maximum individual will be a composite of the highest dose factor of each age group for each organ, hence A_{it} . The following expression from NUREG 0133, Section 4.3 is used to calculate dose:

$$D_i = \sum_L [A_{it} \sum_L (\Delta T_L C_{iL} F_L)]$$

Where:

- D_i = The cumulative dose commitment to the total body or any organ, from the liquid effluents for the total time period (ΔT_L), mrem.
- ΔT_L = The length of the L th time period over which C_{iL} and F_L are averaged for all liquid releases, hours.
- C_{iL} = The average concentration of radionuclide, i , in undiluted liquid effluents during time period ΔT_L from any liquid release, $\mu\text{Ci/ml}$.
- A_{it} = The site related ingestion dose commitment factor to the total body or any organ t for each identified principal gamma or beta emitter for a maximum individual, mrem/hr per $\mu\text{Ci/ml}$.
- F_L = The near field average dilution factor for C_{iL} during any liquid effluent release. Defined as the ratio of the maximum undiluted liquid waste flow during release to the average flow from the site discharge structure to unrestricted receiving waters, unitless.

A_{igt} values for radwaste liquid batch releases at a discharge rate of 295 ft³/sec (one circulating water pump in operation) are presented in tables 1-1 to 1-4. A_{igt} values for an emergency condenser vent release are presented in tables 1-5 to 1-8. The emergency condenser vent releases are assumed to travel to the perimeter drain system and released from the discharge structure at a rate of .33 ft³/sec. See Appendix A for the dose factor A_{igt} derivation. To expedite time the dose is calculated to a maximum individual. This maximum individual is a composite of the highest dose factor A_{igt} of each age group a for each organ t and each nuclide i . If a nuclide is detected for which a factor is not listed, then it will be calculated and included in a revision to the ODCM.

All doses calculated in this manner for each batch of liquid effluent will be summed for comparison with quarterly and annual limits, added to the doses accumulated from other releases in the quarter and year of interest. In all cases, the following relationships will hold:



2.3.1 Maximum Dose Equivalent Pathway (Cont'd)

For a calendar quarter:

$$D_i \leq 1.5 \text{ mrem total body}$$

$$D_i \leq 5 \text{ mrem for any organ}$$

For the calendar year:

$$D_i \leq 3.0 \text{ mrem total body}$$

$$D_i \leq 10 \text{ mrem for any organ}$$

Where:

D_i = total dose received to the total body or any organ due to liquid effluent releases.

If these limits are exceeded, a special report will be submitted to the NRC identifying the cause and proposed corrective actions. In addition, if these limits are exceeded by a factor of two, calculations shall be made to determine if the dose limits contained in 40 CFR 190 have been exceeded. Dose limits, as contained in 40 CFR 190 are total body and organ doses of 25 mrem per year and a thyroid dose of 75 mrem per year.

These calculations will include doses as a result of liquid and gaseous pathways as well as doses from direct radiation. The liquid pathway analysis will only include the fish and sediment pathways since the drinking water pathway is insignificant. This pathway is only included in the station's effluent dose projections to comply with Technical Specifications. Liquid, gaseous and direct radiation pathway doses will consider the James A. FitzPatrick and Nine Mile Point Unit II facilities as well as Nine Mile Point Unit I Nuclear Station.

In the event the calculations demonstrate that the 40 CFR 190 dose limits, as defined above, have been exceeded, then a report shall be prepared and submitted to the Commission within 30 days as specified in Section 3.6.15.d of the Technical Specifications.

Section 4.0 of the ODCM contains more information concerning calculations for an evaluation of whether 40 CFR 190 limits have been exceeded.

2
1
2
3
4
5
6
7
8
9
10
11
12
13
14
15
16
17
18
19
20
21
22
23
24
25
26
27
28
29
30
31
32
33
34
35
36
37
38
39
40
41
42
43
44
45
46
47
48
49
50
51
52
53
54
55
56
57
58
59
60
61
62
63
64
65
66
67
68
69
70
71
72
73
74
75
76
77
78
79
80
81
82
83
84
85
86
87
88
89
90
91
92
93
94
95
96
97
98
99
100



3.0 GASEOUS EFFLUENTS

3.1 Setpoint Determinations

3.1.1 Basis

Stack gas monitor setpoints will be established such that the instantaneous release rate of radioactive materials in gaseous effluents does not exceed the 10 CFR 20 limits for annual release rate. The setpoints will be activated if the instantaneous dose rate at or beyond the (land) site boundary would exceed 500 mrem/yr to the whole body or 3000 mrem/yr to the skin from the continuous release of radioactive noble gas in the gaseous effluent.

The offgas (condenser air ejector activity) monitor setpoints provide assurance that the total body exposure to an individual at the exclusion area boundary does not exceed a small fraction of the dose guidelines of 10 CFR 100.

Emergency condenser vent monitor setpoints will be established such that the release rate for radioactive materials in gaseous effluents do not exceed the 10 CFR 20 limits for annual release rate over the projected longest period of release.

Monitor setpoints from continuous release points will be determined once per quarter under normal release rate conditions and will be based on the isotopic composition of the actual release in progress, or an offgas isotopic distribution or a more conservative default composition specified in the pertinent procedure. If the calculated setpoint is higher than the existing setpoint, it is not mandatory that the setpoint be changed.

Monitor setpoints for emergency condenser vent monitors are conservatively fixed at 5 mr/hr for reasons described in Sections 3.1.4 and therefore do not require periodic recalculations.

Under abnormal site release rate conditions, monitor alarm setpoints from continuous release points will be recalculated and, if necessary, reset at more frequent intervals as deemed necessary by Chemistry Supervision. In particular, contributions from both JAF and NMP-2 and the Emergency Condenser Vents shall be assessed.

During outages and until power operation is again realized, the last operating stack and off gas monitor alarm setpoints shall be used.

Since monitors respond to noble gases only, monitor alarm points are set to alarm prior to exceeding the corresponding total body dose rates.

The skin dose rate limit is not used in setpoint calculations because it is never limiting.

3.1.2 Stack Monitor Setpoints

The detailed methods for establishing setpoints shall be contained in the station procedures. These methods shall apply the following general criteria:

(1) Rationale for Stack monitor settings is based on the general equation:

$$\frac{\text{release rate, actual}}{\text{corresp. dose rate, actual}} = \frac{\text{release rate, max. allowable}}{\text{corresp. dose rate, max. allowable}}$$
$$\frac{\sum Q_i}{\sum Q_i (V_i + (SF) K_i (X/Q)_i)} = \frac{(Q)_{\max}}{500 \text{ mrem/yr}}$$



3.1.2 Stack Monitor Setpoints (Cont'd)

Where:

- Q_i = release rate for each isotope i , $\mu\text{Ci}/\text{sec}$.
- V_i = gamma whole body dose factor in units of mrem/yr per $\mu\text{Ci}/\text{sec}$. (See Table 3-2).
- $(Q)_{\text{max}}$ = instantaneous release rate limit $\mu\text{Ci}/\text{sec}$.

- (2) To ensure that 10 CFR 20 and Technical Specifications dose rate limits are not exceeded, the Hi Hi alarms on the stack monitors shall be set lower than or equal to $(0.9) (Q)_{\text{max}}$. Hi alarms shall be set lower than or equal to $(0.5) (Q)_{\text{max}}$.
- (3) Based on the above conservatism, the dose contribution from JAF and NMP-2 can usually be ignored. During Emergency Classifications at JAF or NMP-2 due to airborne effluent, or after emergency condenser vent releases of significant proportions, the 500 mrem/yr value may be reduced accordingly.
- (4) To convert monitor gross count rates to $\mu\text{Ci}/\text{sec}$ release rates, the following general formula shall be applied:

$$(C_m - B) K_s = Q = \mu\text{Ci}/\text{sec}, \text{ release rate}$$

Where:

- C_m = monitor gross count rate in cps or cpm
- B = monitor background count rate
- K_s = stack monitor efficiency factor with units of $\mu\text{Ci}/\text{sec-cps}$ or $\mu\text{Ci}/\text{sec-cpm}$

- (5) Monitor K_s factors shall be determined using the general formula:

$$K_s = \sum_i Q_i / (C_m - B)$$

Where:

- Q_i = individual radionuclide stack effluent release rate as determined by isotopic analysis.

K_s factors more conservative than those calculated by the above methodology may be assumed.

Alternatively, when stack release rates are near the lower limit of detection, the following general formula may be used to calculate k_s :

$$1/k_s = \frac{E}{f} = \frac{(\sum_i E_i \sum_j Y_j E_{ij}) (3.7E4 \text{day})}{f \text{ Sec. } - \mu\text{Ci}}$$

Where:

- f = stack flow in cc/sec .
- E = efficiency in units of $\text{cpm-cc}/\mu\text{Ci}$ or $\text{cps-cc}/\mu\text{Ci}$ (cpm = counts per minute; cps = counts per second).
- E_i = $\text{cpm-cc}/\text{bps}$ or $\text{cps-cc}/\gamma\text{ps}$.

From energy calibration curve produced during NIST traceable primary gas calibration or transfer source calibration (bps = beta per second; γps = gammas per second).



3.1.2 Stack Monitor Setpoints (Cont'd)

- Y_k = b/d (betas/disintegration) or γ /d (gammas/disintegration).
 F_i = Activity fraction of nuclide i in the mixture.
i = nuclide counter.
k = discrete energy beta or gamma emitter per nuclide counter.
s = seconds.

This monitor calibration method assumes a noble gas distribution typical of a recoil release mechanism. To ensure that the calculated efficiency is conservative, beta or gamma emissions whose energy is above the range of calibration of the detector are not included in the calculation.

3.1.3 Recombiner Discharge (Off Gas) Monitor Setpoints

- (1) The Hi-Hi alarm points shall activate with recombinder discharge rates equal to or less than 500,000 μ Ci/sec. This alarm point may be set equal to or less than 1 Ci/sec for a period of time not to exceed 60 days provided the offgas treatment system is in operation. According to the Unit 1 Technical Specifications, Note (C) to Table 4.6.14-2, the channel functional test of the condenser air ejector radioactivity monitor shall demonstrate that automatic isolation of this pathway occurs if either of the following conditions exist:

- i) Instruments indicate two channels above the Hi-Hi alarm setpoint,
- ii) Instruments indicate one channel above Hi-Hi alarm setpoint and one channel downscale.

This automatic isolation function is tested once per operating cycle in accordance with station procedures.

- (2) The Hi alarm points shall be set to activate at equal to or less than five (5) times normal full power background.

If the monitor alarms at this setpoint, the offgas will be immediately sampled and analyzed, followed by an analysis of reactor coolant sample.

- (3) To convert monitor mR/hr readings to μ Ci/sec, the formula below shall be applied:

$$(R)(K_R) = Q_R \mu\text{Ci/sec recombinder discharge release rate}$$

Where:

R = mR/hr monitor indicator.

K_R = efficiency factor in units of μ Ci/sec/mR/hr determined prior to setting monitor alarm points.

- (4) Monitor K_R factors shall be determined using the general formula:

$$K_R = \sum_i Q_i / R$$

Where:

Q_i = individual radionuclide recombinder discharge release rate as determined by isotopic analysis and flow rate monitor.

K_R factors more conservative than those calculated by the above methodology may be assumed.



3.1.3 Recombiner Discharge (Off Gas) Monitor Setpoints (Cont'd)

- (5) The setpoints chosen provide assurance that the total body exposure to an individual at the exclusion area boundary will not exceed a very small fraction of the limits of 10CFR Part 100 in the event this effluent is inadvertently discharged directly to the environment without treatment (thereby implementing the requirements of General Design Criteria 60 and 64 of Appendix A to 10CFR Part 50). Additionally, these setpoints serve to limit buildup of fission product activity within the station systems which would result if high fuel leakage were to be permitted over extended periods.

3.1.4 Emergency Condenser Vent Monitor Setpoint

The monitor setpoint was established by calculation ("Emergency Condenser Vent Monitor Alarm Setpoint", January 13, 1986, NMPC File Code #16199). Assuming a hypothetical case with (1) reactor water iodine concentrations higher than the Technical Specification Limit, (2) reactor water noble gas concentrations higher than would be expected at Technical Specification iodine levels, and (3) leakage of reactor steam into the emergency condenser shell at 300% of rated flow (or 1.3 E6 lbs/hr), the calculation predicts an emergency condenser vent monitor response of 20 mR/hr. Such a release would result in less than 10 CFR 20 dose rate values at the site boundary and beyond for typical emergency condenser cooldown periods.

Since a 20 mR/hr monitor response can, in theory, be achievable only when reactor water iodines are higher than permitted by Technical Specifications, a conservative monitor setpoint of 5 mR/hr has been adopted.

3.1.5 Discussion

3.1.5.1 Stack Effluent Monitoring System Description

The NMP-1 Stack Effluent Monitoring System consists of two subsystems; the Radioactive Gaseous Effluent Monitoring System (RAGEMS) and the old General Electric Stack Monitoring System (OGESMS). During normal operation, the OGESMS shall be used to monitor station noble gas effluents and collect particulates and iodine samples in compliance with Technical Specification requirements.

The RAGEMS is designed to be promptly activated from the Main Control Room for use in high range monitoring during accident situations in compliance with NUREG 0737 criteria. Overall system schematic for the OGESMS and RAGEMS are shown on Figure B-9. A simplified view of RAGEMS Showing Unit 0, 1, 2, 3 and 4 can be found on Figure B-8.

The RAGEMS can provide continuous accident monitoring and on-line isotopic analysis of NMP-1 stack effluent noble gases at Lower Levels of Detection less than Technical Specification Table 4.6.15-2 limits. Activities as low as 5.0E-8 and as high as 2.0E5 $\mu\text{Ci/cc}$ for noble gases are detectable by the system.

3.1.5.2 Stack Sample Flow Path - RAGEMS

The effluent sample is obtained inside the stack at elevation 530' using an isokinetic probe with four orifices. The sample line then bends radially out and back into the stack; descends down the stack and out of the stack at approximately elevation 257'; runs horizontally (enclosed in heat tracing) some 270' along the off gas tunnel; and enters the RAGEMS located on the Turbine Building 250' (Dilution cabinet - Unit 0) and Off Gas Building 247' (Particulate, Iodine, Noble Gas stations - Units 1-3).



3.1.5.2 Stack Sample Flow Path - RAGEMS (Cont'd)

In the Dilution cabinet of the RAGEMS, the stack gas may be diluted during accident situations approximately 100-200X (first stage) or 10000-40000 X (first and second stage) with gaseous nitrogen supplied from an on-site liquid nitrogen storage tank (see Figure B-9).

From Unit 0, the sample gas enters Unit 1-3 of RAGEMS and flows thru in-line particulate and iodine cartridges and then thru either a 6 liter (low range) or 30 cc (high range) noble gas chamber. The sample gas next flows back thru Unit 0 and the off gas tunnel; and back into the stack.

3.1.5.3 Stack Sample Flow Path - OGESMS

The OGESMS sample is obtained from the same stack sample probe as the RAGEMS. From the exit of the stack at elevation 257', the sample line runs east approximately 20' and then vertically approximately 8' to the OGESMS skid. In the OGESMS, sample flows thru a particulate/iodine cartridge housing and four noble gas scintillation detectors (i.e., 07 and 08 low range beta detectors and RN-03A and RN-03B high range gamma detectors). From OGESMS, the stack sample flows back into the stack at approximately elevation 257'.

All OGESMS detector outputs are monitored and recorded remotely in the Main Control Room. Alarming capabilities are provided to alert Operators of high release rate conditions prior to exceeding Technical Specification 3.6.15.b (1) a dose rate limits.

Stack particulate and iodine samples are retrieved manually from the OGESMS and analyzed in the laboratory using gamma spectroscopy at frequencies and LLDs specified in Table 4.6.15-2 of the Technical Specifications.

3.1.5.4 Sampling Frequency/Sample Analysis

Regardless of which stack monitoring subsystem is utilized, radioactive gaseous wastes shall be sampled and analyzed in accordance with the sampling and analysis program specified in Technical Specification Table 4.6.15-2. Particulate samples are saved and analyzed for principal gamma emitters, gross alpha, Fe-55, Sr-89, Sr-90 at monthly intervals minimally. The latter three analyses are performed off-site from a composite sample. Sample analysis frequencies are increased during elevated release rate conditions, following startup, shutdown and in conjunction with each drywell purge.

Consistent with Technical Specification Table 4.6.15-2, stack effluent tritium is sampled monthly, during each drywell purge, and weekly when fuel is off loaded until stable release rates are demonstrated. Samples are analyzed off-site.

Line loss correction factors are applied to all particulate and iodine results. Correction factors of 2.0 and 1.5 are used for data obtained from RAGEMS and OGESMS respectively. These correction factors are based on empirical data from sampling conducted at NMP-1 in 1985 (memo from J. Blasiak to RAGEMS File, 1/6/86, "Stack Sample Representativeness Study: RAGEMS versus In-Stack Auxiliary Probe Samples").

3.1.5.5 I-133 Estimates

Monthly, the stack effluent shall be sampled for iodines over a 24 hour period and the I-135/I-131 and the I-133/I-131 ratios calculated. These ratios shall be used to calculate I-133, I-135 release for longer acquisition samples collected during the month.



3.1.5.5 I-133 Estimates (Cont'd)

Additionally, the I-135/I-131 and I-133/I-131 ratios should also be determined after a significant change in the ratio is suspected (eg, plant status changes from prolonged shutdown to power operation or fuel damage has occurred).

3.1.5.6 Gaseous Radwaste Treatment System Operation

Technical Specification 3.6.16.b requires that the gaseous radwaste treatment system shall be operable and shall be used to reduce radioactive materials in gaseous waste prior to their discharge as necessary to meet the requirements of Technical Specification 3.6.15.b.

To ensure Technical Specification 3.6.15.b limits are not exceeded, and to confirm proper radwaste treatment system operation as applicable, cumulative dose contributions for the current calendar quarter and current calendar year shall be determined monthly in accordance with section 3.2 of this manual. Initial dose calculations shall incorporate the following assumptions with regard to release rates of non-gamma emitting radionuclides subsequently analyzed off-site:

- a) H-3 release rate $\leq 4 \mu\text{Ci/sec}$
- b) Sr-89 release rate $\leq 4 \times \text{Cs-137 release rate}$
- c) Sr-90 release rate $\leq 0.5 \times \text{Cs-137 release rate}$
- d) Fe-55 release rate $\leq 1 \times \text{Co-60 release rate}$

Assumed release rates represent conservative estimates derived from analysis of historical data from effluent releases and process waste streams (See NMP 34023, C. Ware to J. Blasiak, April 29, 1988, "Dose Estimates for Beta-Emitting Isotopes"). Following receipt of off-site H-3, Sr-89, Sr-90, Fe-55 analysis information, dose estimates shall be revised using actual radionuclide concentrations.

3.2 Dose and Dose Rate Determinations

In accordance with specifications 4.6.15.b.(1), 4.6.15.b.(2), and 4.6.15.b.(3) dose and dose rate determinations will be made monthly to determine:

- (1) Total body dose rates and gamma air doses at the maximum X/Q land sector site boundary interface and beyond.
- (2) Skin dose rates and beta air doses at the maximum X/Q land sector site boundary interface and beyond.
- (3) The critical organ dose and dose rate at the maximum X/Q land sector site boundary interface and at a critical receptor location beyond the site boundary.

Average meteorological data (ie, maximum five year annual average X/Q and D/Q values in the case of elevated releases or 1985 annual average X/Q and D/Q values, in the case of ground level releases) shall be utilized for dose and dose rate calculations. Where average meteorological data is assumed, dose and dose rates due to noble gases at locations beyond the site boundary will be lower than equivalent site boundary dose and dose rates. Therefore, under these conditions, calculations of noble gas dose and dose rates beyond the maximum X/Q land sector site boundary locations can be neglected.

The frequency of dose rate calculations will be upgraded when elevated release rate conditions specified in subsequent sections 3.2.1.1 and 3.2.1.2 are realized.



3.2 Dose and Dose Rate Determinations (Cont'd)

Emergency condenser vent release contributions to the monthly dose and dose rate determinations will be considered only when the emergency condenser return isolation valves have been opened for reactor cooldown, if Emergency Condenser tube leaks develop with or without the system's return isolation valve opened, or if significant activity is detected in the Emergency Condenser Shell.

Without tube leakage dose contributions from emergency condenser vent releases are to be determined based on condensate storage tank and emergency condenser shell isotopic distributions.

When releases from the emergency condenser have occurred, dose rate and dose determinations shall be performed using methodology in 3.2.1 and 3.2.2. Furthermore, environmental sampling may also be initiated to refine any actual contribution to doses. See Section 3.4.

Critical organ doses and dose rates may be conservatively calculated by assuming the existence of a maximum individual. This individual is a composite of the highest dose factor of each age group, for each organ and total body, and each nuclide. It is assumed that all pathways are applicable and the highest X/Q and/or D/Q value for actual pathways as noted in Table 3-1 are in effect. The maximum individual's dose is equal to the same dose that person would receive if they were simultaneously subjected to the highest pathway dose at each critical receptor identified for each pathway. The pathways include grass-(cow and goat)-milk, grass-cow-meat, vegetation, ground plane and inhalation. To comply with Technical Specifications we will calculate the maximum individual dose rate at the site boundary and beyond at the critical residence.

If dose or dose rates calculated, using the assumptions noted above, reach Technical Specification limits, actual pathways will be evaluated, and dose/dose rates shall be calculated at separate critical receptor locations and compared with applicable limits.

3.2.1 Dose Rate

Dose rates will be calculated monthly, at a minimum, or when the Hi-Hi stack monitor alarm setpoint is reached, to demonstrate that dose rates resulting from the release of noble gases, tritium, iodines, and particulates with half lives greater than 8 days are within the limits specified in 10CFR.20. These limits are:

Noble Gases

Whole Body Dose Rate:	500 mrem/yr
Skin Dose Rate:	3000 mrem/yr

Tritium, Iodines and Particulates

Organ Dose Rate:	1500 mrem/yr
------------------	--------------

3.2.1.1 Noble Gases

The following noble gas dose rate equation includes the contribution from the stack (s) elevated release and the emergency condenser vent (v) ground level release when applicable (See section 3.2).

To ensure that the site noble gas dose rate limits are not exceeded, the following procedural actions are taken if the offsite dose rates from Unit 1 exceed 10% of the limits:

- 1) Notify the Unit 1 SSS (Station Shift Supervisor) and Unit 1 Supervisor Chemistry.



3.2.1.1 Noble Gases (Cont'd)

- 2) Notify the Unit 2 SSS and Unit 2 Supervisor Chemistry and request the Unit 2 contribution to offsite dose.
- 3) Notify the SSS of the James A. Fitzpatrick Nuclear Plant and request the Fitzpatrick contribution to offsite dose.
- 4) Increase the frequency of performing noble gas dose calculations, if necessary, to ensure Site (Nine Mile Point Units 1 and 2 and Fitzpatrick) limits are not exceeded.

Additionally, alarm setpoints are set at 50% of the dose rate limit to ensure that site limits are not exceeded. This alarm setpoint is adjusted if the noble gas dose rate from Unit 1 is greater than 10% of the limit.

For total body dose rates (mrem/sec):

$$DR_{\gamma} \text{ (mrem/sec)} = 3.17E-8 \sum_i [(V_i + (SF)K_i(X/Q)_s)Q_{is} + (SF)K_i(X/Q)_v Q_{iv}]$$

For skin dose rates (mrem/sec):

$$DR_{\gamma+\beta} \text{ (mrem/sec)} = 3.17E-8 \sum_i [(L_i(X/Q)_s + 1.11(SF)(B_i + M_i(X/Q)_s))Q_{is} + \dots \\ \dots (L_i + 1.11(SF)M_i)(X/Q)_v Q_{iv}]$$

Where:

DR_{γ} = total body gamma dose rate (mrem/sec).

$DR_{\gamma+\beta}$ = skin dose rate from gamma and beta radiation (mrem/sec).

V_i = the constant accounting for the gamma whole body dose rate from stack radiation for an elevated finite plume releases for each identified noble gas nuclide, i. Listed on Table 3-2 in mrem/yr per $\mu\text{Ci/sec}$.

K_i = the constant accounting for the gamma whole body dose rate from immersion in the semi-infinite cloud for each identified noble gas nuclide, i. Listed in Table 3-3 in mrem/yr per $\mu\text{Ci/m}^3$ (from Reg. Guide 1.109)

Q_{is}, Q_{iv} = the release rate of isotope i from the stack(s) or vent(v); ($\mu\text{Ci/sec}$)

SF = structural shielding factor.

X/Q = the relative plume concentration (in units of sec/m^3) at the land sector site boundary or beyond. Average meteorological data (Table 3-1) is used. "Elevated" X/Q values are used for stack releases (s = stack); "Ground" X/Q values are used for Emergency Condenser Vent releases (v = vent).

L_i = the constant accounting for the beta skin dose rate from immersion in the semi-infinite cloud for each identified noble gas nuclide, i. Listed in Table 3-3 in mrem/yr per $\mu\text{Ci/m}^3$ (from Reg. Guide 1.109)

B_i = the constant accounting for the air gamma radiation from the elevated finite plume resulting from stack releases for each identified noble gas nuclide, i. Listed in Table 3-2 in mrad/yr per $\mu\text{Ci/sec}$.



3.2.1.1 Noble Gases (Cont'd)

M_i = the constant accounting for the gamma air dose rate from immersion in the semi-infinite cloud for each identified noble gas nuclide, i . Listed in Table 3-3 in mrad/yr per $\mu\text{Ci}/\text{m}^3$ (from Reg. Guide 1.109)

See Appendix B for derivation of B_i and V_i .

3.2.1.2 Tritium, Iodines and Particulates

To ensure that the 1500 mrem/year site dose rate limit is not exceeded, offsite dose rates for tritium, iodine and particulates with half lives greater than 8 days shall be calculated monthly and when release rates (Q) exceed $0.34 \mu\text{Ci}/\text{sec}$ using the following equation.

$$D_{ak} \text{ (mrem/sec)} = 3.17\text{E-}8 \sum_j [\sum_i R_{ijk} [W_s Q_s + W_v Q_v]]$$

Where:

D_{ak} = Total dose rate to each organ k of an individual in age group a (mrem/sec).

W_j = dispersion parameter either X/Q (sec/m^3) or D/Q ($1/\text{m}^2$) depending on pathway and receptor location assumed. Average meteorological data is used (Table 3-1). "Elevated" W_j values are used for stack releases ($s = \text{stack}$); "Ground" W_j values are used for Emergency Condenser Vent releases ($v = \text{vent}$).

Q_i = the release rate of isotope i , from the stack (s) or vent (v); ($\mu\text{Ci}/\text{sec}$).

R_{ijk} = the dose factor for each isotope i , pathway j , age group a , and organ k (Table 3-4, through 3-22; $\text{m}^2\text{-mrem}/\text{yr}$ per $\mu\text{Ci}/\text{sec}$ for all pathways except inhalation, mrem/yr per $\mu\text{Ci}/\text{m}^3$). The R values contained in Tables 3-4 through 3-22 were calculated using the methodology defined in NUREG-0133 and parameters from Regulatory Guide 1.109, Revision 1; as presented in Appendix C.

$3.17\text{E-}8 =$ the inverse of the number of seconds in a year.

When the release rate exceeds $0.34 \mu\text{Ci}/\text{sec}$, the dose rate assessment shall also include JAF and NMP-2 contribution.

The use of the $0.34 \mu\text{Ci}/\text{sec}$ release rate threshold to perform dose rate calculations is justified as follows:

- (a) The 1500 mrem/yr organ dose rate limit corresponds to a minimum release rate limit of $0.34 \mu\text{Ci}/\text{sec}$ calculated using the equation:

$$1500 = (Q, \mu\text{Ci}/\text{sec}) \times (R_j W_j)_{\text{max}}$$

Where:

1500 = site boundary dose rate limit (mrem/year).

$(R_j W_j)_{\text{max}}$ = the maximum curie-to-dose conversion factor equal to $4.45\text{E}3$ mrem-sec/ $\mu\text{Ci-yr}$ for Sr-90, child bone at the critical residence receptor location beyond the site boundary.



3.2.1.2 Tritium, Iodines and Particulates (Cont'd)

- (b) The use of 0.34 $\mu\text{Ci}/\text{sec}$ release rate threshold and the $4.45\text{E}3$ mrem-sec/ $\mu\text{Ci}\cdot\text{yr}$ curie-to-dose conversion factor is conservative since curie-to-dose conversion factors for other isotopes likely to be present are significantly lower.

In addition, if the organ dose rate exceeds 5% of the annual limit, the following procedural actions will be taken:

- 1) Notify the Unit 1 SSS (Station Shift Supervisor) and Unit 1 Supervisor Chemistry.
- 2) Notify the Unit 2 SSS and Unit 2 Supervisor Chemistry and request the Unit 2 contribution to offsite dose.
- 3) Notify the SSS of the James A. Fitzpatrick contribution to offsite dose.
- 4) Increase the frequency of performing dose calculations if necessary to ensure site (Nine Mile Point Units 1 and 2 and Fitzpatrick) limits are not exceeded.

3.2.2 Dose

Calculations will be performed monthly at a minimum, to demonstrate that doses resulting from the release of noble gases, tritium, iodines, and particulates with half lives greater than 8 days are within the limits specified in 10 CFR 50, Appendix I. These limits are:

Noble Gases

5 mR gamma/calendar quarter
10 mrad beta/calendar quarter
10 mR gamma/calendar year
20 mrad beta/calendar year

Tritium, Iodines and Particulates

7.5 mrem to any organ/calendar quarter
15 mrem to any organ/calendar year

3.2.2.1 Noble Gas Air Dose

The following Noble Gas air dose equation includes contributions from the stack (s) elevated release and the emergency condenser vent (v) ground level release when applicable (see section 3.2):

For gamma radiation¹ (mrad):
$$D_{\gamma} \text{ (mrad)} = 3.17\text{E}-8 \sum_i [M_i(X/Q)_v \cdot Q_{iv} + (B_i + M_i(X/Q)_s) \cdot Q_{is}] \cdot t$$

For beta radiation (mrad):
$$D_{\beta} \text{ (mrad)} = 3.17\text{E}-8 \sum_i N_i [(X/Q)_v \cdot Q_{iv} + (X/Q)_s \cdot Q_{is}] \cdot t$$

Where:

D_{γ} = gamma air dose (mrad).
 D_{β} = beta air dose (mrad).

¹ Note that the units for the gamma air dose are in mrad compared to the units for the limits are in mR. The NRC recognizes that 1 mR=1 mrad, for gamma radiation.



3.2.2.1 Noble Gas Air Dose (Cont'd)

B_i	=	the constant accounting for the air gamma radiation from the elevated finite plume resulting from stack releases for each identified noble gas nuclide, i. Listed in Table 3-2 in mrad/yr per $\mu\text{Ci}/\text{sec}$.
N_i	=	The constant accounting for the air beta dose from immersion in the semi-infinite cloud for each identified noble gas nuclide, i. Listed on Table 3-3 in mrad/yr per $\mu\text{Ci}/\text{m}^3$ (from Reg. Guide 1.109).
Q_{is}, Q_{iv}	=	the release rate of isotope i, from the stack (s) or vent (v); ($\mu\text{Ci}/\text{sec}$).
$3.17\text{E}-8$	=	the inverse of the number of seconds in a year.
M_i	=	the constant accounting for the air gamma dose from immersion in the semi-infinite cloud for each identified noble gas nuclide, i. Listed on Table 3-3 in mrad/yr per $\mu\text{Ci}/\text{m}^3$ (from Reg. Guide 1.109).
t	=	total time during release period, sec.

All other parameters are as defined in section 3.2.1.1.

3.2.2.2 Tritium, Iodines and Particulates

To ensure that the 15 mrem/yr facility dose limit is not exceeded, offsite doses for tritium, iodines, and particulates with half lives greater than 8 days shall be calculated monthly using the following equation:

$$D_{ak} \text{ (mrem)} = 3.17\text{E}-8 \sum_j [\sum_i R_{ijk} [W_s Q_{is} + W_v Q_{iv}]] \cdot t$$

Where:

D_{ak}	=	total dose to each organ k of an individual in age group a (mrem).
W_j	=	dispersion parameter either X/Q (sec/m^3) or D/Q ($1/\text{m}^2$) depending on pathway and receptor location assumed. Average meteorological data is used (Table 3-1). "Elevated" W_j values are used for stack releases (s = stack); "Ground" W_j values are used for Emergency Condenser Vent releases (v = vent).
Q_{is}, Q_{iv}	=	the release rate of isotope i from stack(s) or vent (v); ($\mu\text{Ci}/\text{sec}$).
R_{ijk}	=	the dose factor for each isotope i, pathway j, age group a, and organ k (Tables 3-4, through 3-22; $\text{m}^2\text{-mrem}/\text{yr}$ per $\mu\text{Ci}/\text{sec}$). R values contained in Tables 3-4 through 3-22 were calculated using the methodology defined in NUREG-0133 and parameters from Regulatory Guide 1.109, Revision 1; as presented in Appendix C.
$3.17\text{E}-8$	=	the inverse of the number of seconds in a year.
t	=	total time during the release period, sec.



3.2.2.3 Accumulating Doses

Doses will be calculated monthly, at a minimum, for gamma air, beta air, and the critical organ for each age group. Dose estimates will, also, be calculated monthly prior to receipt of any offsite analysis data i.e., strontium, tritium, and iron-55. Results will be summed for each calendar quarter and year.

The critical doses are based on the following:

- noble gas plume air dose
- direct radiation from ground plane deposition
- inhalation dose
- cow milk ingestion dose
- goat milk ingestion dose
- cow meat ingestion dose
- vegetation (food crops) ingestion dose

The quarterly and annual results shall be compared to the limits listed in paragraph 3.2.2. If the limits are exceeded, special reports, as required by Section 6.9.3 of the Technical Specification, shall be submitted.

3.3 Critical Receptors

In accordance with the provisions of 10 CFR 20 and 10 CFR 50, Appendix I, the critical receptors have been identified and are contained in Table 3-1.

For elevated noble gas releases the critical receptor is the site boundary.

When 1985 average annual X/Q values are used for ground level noble gas releases, the critical receptor is the maximum X/Q land sector site boundary interface.

For tritium, iodines, and particulates with half lives greater than eight days, the critical pathways are grass-(cow and goat)-milk, grass-cow meat, vegetation, inhalation and direct radiation (ground plane) as a result of ground deposition.

The grass-(cow and goat)-milk, and grass-cow-meat pathways will be based on the greatest D/Q location. This location has been determined in conjunction with the land use census (technical specification 3.6.22) and is subject to change. The vegetation (food crop) pathway is based on the greatest D/Q garden location from which samples are taken. This location may also be modified as a result of vegetation sampling surveys.

The inhalation and ground plane dose pathways will be calculated at the critical residence.

Because the Technical Specifications state to calculate "at the site boundary and beyond", the doses and/or dose rates must be calculated for a maximum individual who is exposed to all pathways at the site boundary and at the critical residence. The maximum individual is a composite of the highest dose factor of each age group, for each organ and total body, and each nuclide. Since the critical residence location has the greatest occupancy time, the resultant dose at the residence including all pathways is limiting. However, due to the Technical Specification wording, the inhalation and ground plane dose at the site boundary along with all other pathways, will be calculated assuming a continuous occupancy time.

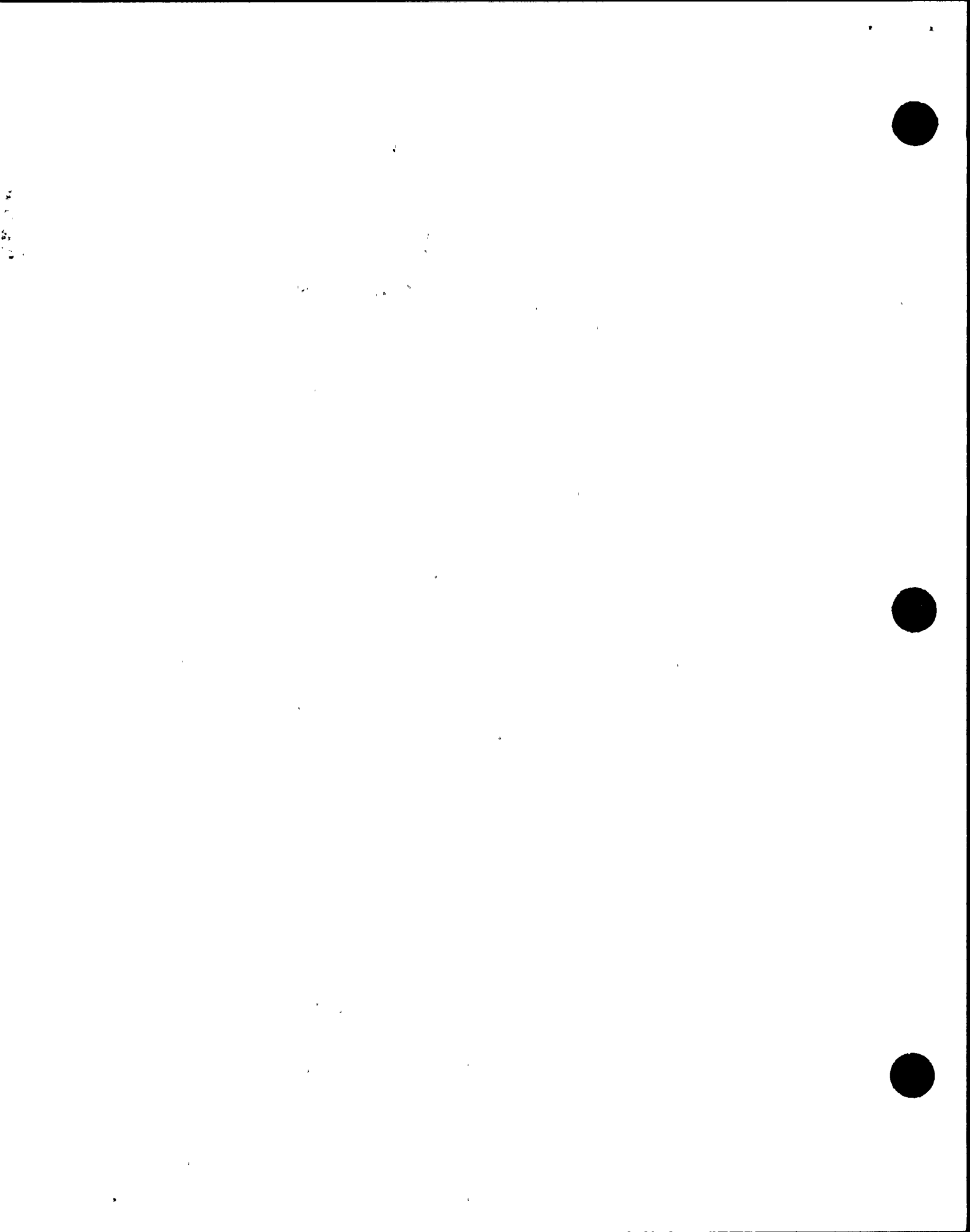

3.3

Critical Receptors (Cont'd)

In lieu of correcting land site boundary ground plane and inhalation dose factors for occupancy time, a Technical Specification change will be submitted to change the requirement from calculating "at the site boundary and beyond" to "at the site boundary or beyond". Unit 1 will then calculate at the critical residence since this should be the limiting dose. Until this change is effective, the dose and/or dose rate calculations for tritium, iodines, and particulates with half lives greater than 8 days will conservatively assume that the ground plane and inhalation pathway critical receptors are at the site boundary, i.e., X/Q and D/Q, respectively, are calculated at the site boundary.

3.4

Refinement of Offsite Doses Resulting from Emergency Condenser Vent Releases

The doses resulting from the operation of the emergency condensers and calculated in accordance with 3.2.2 may be refined using data from actual environmental samples. Ground deposition samples will be obtained from an area or areas of maximum projected deposition. These areas are anticipated to be at or near the site boundary and near projected plume centerline. Using the methodology found in Regulatory Guide 1.109, the dose will be calculated to the maximum exposed individual. This dose will then be compared to the dose calculated in accordance with 3.2.2. The comparison will result in an adjustment factor of less than or greater than one which will be used to adjust the other doses from other pathways. Other environmental samples may also be collected and the resultant calculated doses to the maximum exposed individual compared to the dose calculated per 3.2.2. Other environmental sample media may include milk, vegetation (such as garden broadleaf vegetables), etc. The adjustment factors from these pathways may be applied to the doses calculated per 3.2.2 on a pathway by pathway basis or several pathway adjustment factors may be averaged and used to adjust calculated doses.

Doses calculated from actual environmental sample media will be based on the methodology presented in Regulatory Guide 1.109. The regulatory guide equations may be slightly modified to account for short intervals of time (less than one year) or modified for simplicity purposes by deleting decay factors. Deletion of decay factors would yield more conservative results.



40 CFR 190 REQUIREMENTS

The "Uranium Fuel Cycle" is defined in 40 CFR Part 190.02 (b) as follows:

"Uranium fuel cycle means the operations of milling of uranium ore, chemical conversion of uranium, isotopic enrichment of uranium, fabrication of uranium fuel, generation of electricity by a light-water-cooled nuclear power plant using uranium fuel, and reprocessing of spent uranium fuel, to the extent that these directly support the production of electrical power for public use utilizing nuclear energy, but excludes mining operations, operations at waste disposal sites, transportation of any radioactive material in support of these operations, and the reuse of recovered non-uranium special nuclear and by-product materials from the cycle."

Section 3.6.15.d of the Technical Specifications requires that when the calculated doses associated with the effluent releases exceed twice the applicable quarter or annual limits, the licensee shall evaluate the calendar year doses and, if required, submit a Special Report to the NRC and limit subsequent releases such that the dose commitment to a real individual from all uranium fuel cycle sources is limited to 25 mrem to the total body or any organ (except the thyroid, which is limited to 75 mrem). This report is to demonstrate that radiation exposures to all real individuals from all uranium fuel cycle sources (including all liquid and gaseous effluent pathways and direct radiation) are less than the limits in 40 CFR Part 190. If releases that result in doses exceeding the 40 CFR 190 limits have occurred, then a variance from the NRC to permit such releases will be requested and if possible, action will be taken to reduce subsequent releases.

The report to the NRC shall contain:

- 1) Identification of all uranium fuel cycle facilities or operations within 5 miles of the nuclear power reactor units at the site that contribute to the annual dose of the maximum exposed member of the public.
- 2) Identification of the maximum exposed member of the public and a determination of the total annual dose to this person from existing pathways and sources of radioactive effluents and direct radiation.

The total body and organ doses resulting from radioactive material in liquid effluents from Nine Mile Point Unit 1 will be summed with the maximum doses resulting from the releases of noble gases, radioiodines, and particulates for the other calendar quarters (as applicable) and from the calendar quarter in which twice the limit was exceeded. The direct dose components will be determined by either calculation or actual measurement. Actual measurements will utilize environmental TLD dosimetry. Calculated measurements will utilize engineering calculations to determine a projected direct dose component. In the event calculations are used, the methodology will be detailed as required in Section 6.9.1.e of the Technical Specifications.

22
.
:
2



The doses from Nine Mile Point Unit 1 will be added to the doses to the maximum exposed individual that are contributed from other uranium fuel cycle operations within 5 miles of the site. Other uranium fuel cycle facilities within 5 miles of the Site include Nine Mile Point Nuclear Station Unit 2 and the James A. Fitzpatrick Nuclear Power Plant. Doses from other facilities will be calculated in accordance with each facilities' ODCM.

For the purpose of calculating doses, the results of the Radiological Environmental Monitoring Program may be included for providing more refined estimates of doses to a real maximum exposed individual. Estimated doses, as calculated from station effluents, may be replaced by doses calculated from actual environmental sample results. Reports will include all significant details of the dose determination if radiological sampling and analyses are used to determine if the dose limits of 40CFR190 are exceeded.

4.1 Evaluation of Doses From Liquid Effluents

For the evaluation of doses to real members of the public from liquid effluents, the fish consumption and shoreline sediment ground dose will be considered. Since the doses from other aquatic pathways are insignificant, fish consumption and shoreline sediment are the only two pathways that will be considered. The dose associated with fish consumption may be calculated using effluent data and Regulatory Guide 1.109 methodology or by calculating a dose to man based on actual fish sample analysis data. Because of the nature of the receptor location and the extensive fishing in the area, the critical individual may be a teenager or an adult. The dose associated with shoreline sediment is based on the assumption that the shoreline would be utilized as a recreational area. This dose may be derived from liquid effluent data and Regulatory Guide 1.109 methodology or from actual shoreline sediment sample analysis data.

Equations used to evaluate doses from actual fish and shoreline sediment samples are based on Regulatory Guide 1.109 methodology. Because of the sample medium type and the half-lives of the radionuclides historically observed, the decay corrected portions of the equations are deleted. This does not reduce the conservatism of the calculated doses but increases the simplicity from an evaluation point of view. Table 3-23 presents the parameters used for calculating doses from liquid effluents.

The dose from fish sample media is calculated as:

$$R_{apj} = \sum_i [C_{if} (U) (D_{aifj}) f] (1E+3)$$

Where:

R_{apj} = The total annual dose to organ j, of an individual of age group a, from nuclide i, via fish pathway p, in mrem per year.

C_{if} = The concentration of radionuclide i in fish samples in pCi/gram.

U = The consumption rate of fish in kg/yr.

1E+3 = Grams per kilogram.



4.1 Evaluation of Doses From Liquid Effluents (Cont'd)

(D_{ajp}) = The ingestion dose factor for age group a, nuclide i, fish pathway p, and organ j, (Reg. Guide 1.109, Table E-11) (mrem/pCi).

f = The fractional portion of the year over which the dose is applicable.

The dose from shoreline sediment sample media is calculated as:

$$R_{apj} = \sum_i [C_i (U) (4E+4) (0.3) (D_{ajp}) f]$$

Where:

R_{apj} = The total annual dose to organ j, of an individual of age group a, from nuclide i, via the sediment pathway p, in mrem per year.

C_i = The concentration of radionuclide i in shoreline sediment in pCi/gram.

U = The usage factor, (hr/yr) (Reg. Guide 1.109).

4E+4 = The product of the assumed density of shoreline sediment (40 kilogram per square meter to a depth of 2.5 cm) times the number of grams per kilogram.

0.3 = The shore width factor for a lake.

D_{ajp} = The dose factor for age group a, nuclide i, sediment pathway s, and organ j. (Reg. Guide 1.109, Table E-6) (mrem/hr per pCi/m²).

f = The fractional portion of the year over which the dose is applicable.

4.2 Evaluation of Doses From Gaseous Effluents

For the evaluation of doses to real members of the public from gaseous effluents, the pathways contained in section 3:2.2.3 of the ODCM will be considered. These include the deposition, inhalation cows milk, goats milk, meat, and food products (vegetation). However, any updated field data may be utilized that concerns locations of real individuals, real time meteorological data, location of critical receptors, etc. Data from the most recent census and sample location surveys should be utilized. Doses may also be calculated from actual environmental sample media, as available. Environmental sample media data such as TLD, air sample, milk sample and vegetable (food crop) sample data may be utilized in lieu of effluent calculational data.

Doses to member of the public from the pathways contained in ODCM section 3.2.2.3 as a result of gaseous effluents will be calculated using the dose factors of Regulatory Guide 1.109 or the methodology of the ODCM, as applicable. Doses calculated from environmental sample media will be based on the methodologies found in Regulatory Guide 1.109.



4.3 Evaluation of Doses From Direct Radiation

The dose contribution as a result of direct radiation shall be considered when evaluating whether the dose limitations of 40 CFR 190 have been exceeded.

Direct radiation doses as a result of the reactor, turbine and radwaste buildings and outside radioactive storage tanks (as applicable) may be evaluated by engineering calculations or by evaluating environmental TLD results at critical receptor locations, site boundary or other special interest locations. For the evaluation of direct radiation doses utilizing environmental TLDs, the critical receptor in question, such as the critical residence, etc., will be compared to the control locations. The comparison involves the difference in environmental TLD results between the receptor location and the average control location result.

4.4 Doses to Members of the Public Within the Site Boundary

The Semi-Annual Radioactive Effluent Release Report shall include an assessment of the radiation doses from radioactive liquid and gaseous effluents to members of the public due to their activities inside the site boundary as defined by Figure 5.1-1 of the specifications. A member of the public, as defined by the Technical Specifications, would be represented by an individual who visits the sites' Energy Center for the purpose of observing the educational displays or for picnicking and associated activities.

Fishing is a major recreational activity in the area and on the Site as a result of the salmonoid and trout populations in Lake Ontario. Fishermen have been observed fishing at the shoreline near the Energy Center from April through December in all weather conditions. Thus, fishing is the major activity performed by members of the public within the site boundary. Based on the nature of the fishermen and undocumented observations, it is conservatively assumed that the maximum exposed individual spends an average of 8 hours per week fishing from the shoreline at a location between the Energy Center and the Unit 1 facility. This estimate is considered conservative but not necessarily excessive and accounts for occasions where individuals may fish more on weekends or on a few days in March of the year.

The pathways considered for the evaluation include the inhalation pathway, the ground dose pathway with the resultant whole body and skin dose and the direct radiation dose pathway with the associated whole body dose. The direct radiation dose pathway, in actuality, includes several pathways. These include: the direct radiation gamma dose to an individual from an overhead plume, a gamma submersion plume dose (as applicable), possible direct radiation dose from the facility and a ground plane dose (deposition). Because the location is in close proximity to the site, any beta plume submersion dose is felt to be insignificant.

Other pathways, such as the ingestion pathway, are not applicable since these doses are included under calculations for doses to members of the public outside of the site boundary. In addition, pathways associated with water related recreational activities, other than fishing, are not applicable here. These include swimming, boating and wading which are prohibited at the facility.



4.4 Doses to Members of the Public Within the Site Boundary (Cont'd)

The inhalation pathway is evaluated by identifying the applicable radionuclides (radioiodine, tritium and particulates) in the effluent for the appropriate time period. The radionuclide concentrations are then multiplied by the appropriate X/Q value, inhalation dose factor, air intake rate, and the fractional portion of the year in question. Thus, the inhalation pathway is evaluated using the following equation adapted from Regulatory Guide 1.109. Table 3-23 presents the reference for the parameters used in the following equation.

NOTE: The following equation is adapted from equations C-3 and C-4 of Regulatory Guide 1.109. Since many of the factors are in units of pCi/m³, m³/sec., etc., and since the radionuclide decay expressions have been deleted because of the short distance to the receptor location, the equation presented here is not identical to the Regulatory Guide equations.

$$D_{ja} = \sum_i [(C_i)F (X/Q)(DFA)_{ja}(BR)_a t]$$

Where:

- D_{ja} = The maximum dose from all nuclides to the organ j and age group (a) in mrem/yr.
- C_i = The average concentration in the stack release of nuclide i for the period in pCi/m³.
- F = Unit 1 average stack flowrate in m³/sec.
- X/Q = The plume dispersion parameter for a location approximately 0.50 miles west of NMP-1; the plume dispersion parameter is 8.9E-06 (stack) and was obtained from the C.T. Main five year average annual X/Q tables. The stack (elevated) X/Q is conservative when based on 0.50 miles because of the close proximity of the stack and the receptor location.
- $(DFA)_{ja}$ = The dose factor for nuclide i, organ j, and age group a in mrem per pCi (Reg. Guide 1.109, Table E-7).
- $(BR)_a$ = Annual air intake for individuals in age group a in m³ per year (obtained from Table E-5 of Regulatory Guide 1.109).
- t = Fractional portion of the year for which radionuclide i was detected and for which a dose is to be calculated (in years).

10
11
12
13
14



4.4 Doses to Members of the Public Within the Site Boundary (Cont'd)

The ground dose pathway (deposition) will be evaluated by obtaining at least one soil or shoreline sediment sample in the area where fishing occurs. The dose will then be calculated using the sample results, the time period in question, and the methodology based on Regulatory Guide 1.109 as presented in Section 4.1. The resultant dose may be adjusted for a background dose by subtracting the applicable off-site control soil or shoreline sediment sample radionuclide activities. In the event it is noted that fishing is not performed from the shoreline, but is instead performed in the water (i.e., the use of waders), then the ground dose pathway (deposition) may not be evaluated.

The direct radiation gamma dose pathway includes any gamma doses from an overhead plume, potential submersion in the plume, possible direct radiation from the facility and ground plane dose (deposition). This general pathway will be evaluated by average environmental TLD readings. At least two environmental TLDs will be utilized at one location in the approximate area where fishing occurs. The TLDs will be placed in the field on approximately the beginning of a calendar quarter and removed on approximately the end of the calendar quarter. For the purposes of this evaluation, TLD data from quarters 2, 3, and 4 will be utilized.

The average TLD readings will be adjusted by the average control TLD readings. This is accomplished by subtracting the average quarterly control TLD value from the average fishing location TLD value. The applicable quarterly control TLD values will be utilized after adjusting for the appropriate time period (as applicable). In the event of loss or theft of the TLDs, results from a TLD or TLDs in a nearby area may be utilized.

5.0 ENVIRONMENTAL MONITORING PROGRAM

5.1 Sampling Stations

The current sampling locations are specified in Table 5-1 and Figures 5.1-1, 5.1-2. The meteorological tower is shown in Figure 5.1-1. The location is shown as TLD location 17. The Radiological Environmental Monitoring Program is a joint effort between the Niagara Mohawk Power Corporation and the New York Power Authority, the owners and operators of the Nine Mile Point Unit 1 and the James A. FitzPatrick Nuclear Power Plant, respectively. Sampling locations are chosen on the basis of historical average dispersion or deposition parameters from both units. The environmental sampling location coordinates shown on Table 5-1 are based on the NMP-2 reactor centerline.

The average dispersion and deposition parameters have been calculated for a 5 year period, 1978 through 1982. These dispersion calculations are attached as Appendix E.

The calculated dispersion or deposition parameters will be compared to the results of the annual land use census. If it is determined that a milk sampling location exists at a location that yields a significantly higher (e.g. 50%) calculated D/Q rate, the new milk sampling location will be added to the monitoring program within 30 days.

If a new location is added, the old location that yields the lowest calculated D/Q may be dropped from the program after October 31 of that year.

5.2 Interlaboratory Comparison Program

Analyses shall be performed on samples containing known quantities of radioactive materials that are supplied as part of a Commission approved or sponsored Interlaboratory Comparison Program, such as the EPA Crosscheck Program. Participation shall be only for those media, e.g., air, milk, water, etc., that are included in the Nine Mile Point Environmental Monitoring Program and for which crosscheck samples are available. An attempt will be made to obtain a QC sample to program sample ratio of 5% or better. The site identification symbol or the actual Quality Control sample results shall be reported in the Annual Radiological Environmental Operating Report so that the Commission staff may evaluate the results.

Specific sample media for which EPA Cross Check Program samples are available include the following:

- gross beta in air particulate filters
- gamma emitters in air particulate filters
- gamma emitters in milk
- gamma emitters in water
- tritium in water
- I-131 in water

25
20
15
10
5



5.3 Capabilities for Thermoluminescent Dosimeters Used for Environmental Measurements

Required detection capabilities for thermoluminescent dosimeters used for environmental measurements required by Table 4.6.20-1, footnote b of the Technical Specifications are based on ANSI Standard N545, section 4.3. TLDs are defined as phosphors packaged for field use. In regard to the detection capabilities for thermoluminescent dosimeters, only one determination is required to evaluate the above capabilities per type of TLD. Furthermore, the above capabilities may be determined by the vendor who supplies the TLDs. Required detection capabilities are as follows:

- 5.3.1 Uniformity shall be determined by giving TLDs from the same batch an exposure equal to that resulting from an exposure rate of 10 mR/hr during the field cycle. The responses obtained shall have a relative standard deviation of less than 7.5%. A total of at least 5 TLDs shall be evaluated.
- 5.3.2 Reproducibility shall be determined by giving TLDs repeated exposures equal to that resulting from an exposure rate of 10 uR/hr during the field cycle. The average of the relative standard deviations of the responses shall be less than 3.0%. A total of at least 4 TLDs shall be evaluated.
- 5.3.3 Dependence of exposure interpretation on the length of a field cycle shall be examined by placing TLDs for a period equal to at least a field cycle and a period equal to half the same field cycle in an area where the exposure rate is known to be constant. This test shall be conducted under approximate average winter temperatures and approximate average summer temperatures. For these tests, the ratio of the response obtained in the field cycle to twice that obtained for half the field cycle shall not be less than 0.85. At least 6 TLDs shall be evaluated.
- 5.3.4 Energy dependence shall be evaluated by the response of TLDs to photons for several energies between approximately 30 keV and 3 MeV. The response shall not differ from that obtained with the calibration source by more than 25% for photons with energies greater than 80 keV and shall not be enhanced by more than a factor of two for photons with energies less than 80 keV. A total of at least 8 TLDs shall be evaluated.
- 5.3.5 The directional dependence of the TLD response shall be determined by comparing the response of the TLD exposed in the routine orientation with respect to the calibration source with the response obtained for different orientations. To accomplish this, the TLD shall be rotated through at least two perpendicular planes. The response averaged over all directions shall not differ from the response obtained in the standard calibration position by more than 10%. A total of at least 4 TLDs shall be evaluated.
- 5.3.6 Light dependence shall be determined by placing TLDs in the field for a period equal to the field cycle under the four conditions found in ANSI N545, section 4.3.6. The results obtained for the unwrapped TLDs shall not differ from those obtained for the TLDs wrapped in aluminum foil by more than 10%. A total of at least 4 TLDs shall be evaluated for each of the four conditions.

1
2
3
4
5
6
7
8
9
10
11
12
13
14
15
16
17
18
19
20
21
22
23
24
25
26
27
28
29
30
31
32
33
34
35
36
37
38
39
40
41
42
43
44
45
46
47
48
49
50
51
52
53
54
55
56
57
58
59
60
61
62
63
64
65
66
67
68
69
70
71
72
73
74
75
76
77
78
79
80
81
82
83
84
85
86
87
88
89
90
91
92
93
94
95
96
97
98
99
100



5.3.7 Moisture dependence shall be determined by placing TLDs (that is, the phosphors packaged for field use) for a period equal to the field cycle in an area where the exposure rate is known to be constant. The TLDs shall be exposed under two conditions: (1) packaged in a thin, sealed plastic bag, and (2) packaged in a thin, sealed plastic bag with sufficient water to yield observable moisture throughout the field cycle. The TLD or phosphor, as appropriate, shall be dried before readout. The response of the TLD exposed in the plastic bag containing water shall not differ from that exposed in the regular plastic bag by more than 10%. A total of at least 4 TLDs shall be evaluated for each condition.

5.3.8 Self irradiation shall be determined by placing TLDs for a period equal to the field cycle in an area where the exposure rate is less than 10 uR/hr and the exposure during the field cycle is known. If necessary, corrections shall be applied for the dependence of exposure interpretation on the length of the field cycle (ANSI N545, section 4.3.3). The average exposure inferred from the responses of the TLDs shall not differ from the known exposure by more than an exposure equal to that resulting from an exposure rate of 10 uR/hr during the field cycle. A total of at least 3 TLDs shall be evaluated.



TABLE 1-1
Average Energy Per Disintegration

<u>ISOTOPE</u>	<u>\bar{E}_γ mev/dis</u>	<u>(Ref)</u>	<u>\bar{E}_β mev/dis⁽⁴⁾</u>	<u>(Ref)</u>
Ar-41	1.294	(3)	0.464	(3)
Kr-83m	0.00248	(1)	0.0371	(1)
Kr-85	0.0022	(1)	0.250	(1)
Kr-85m	0.159	(1)	0.253	(1)
Kr-87	0.793	(1)	1.32	(1)
Kr-88	1.95	(1)	0.377	(1)
Kr-89	2.22	(2)	1.37	(2)
Kr-90	2.10	(2)	1.01	(2)
Xe-131M	0.0201	(1)	0.143	(1)
Xe-133	0.0454	(1)	0.135	(1)
Xe-133m	0.042	(1)	0.19	(1)
Xe-135	0.247	(1)	0.317	(1)
Xe-135m	0.432	(1)	0.095	(1)
Xe-137	0.194	(1)	1.64	(1)
Xe-138	1.18	(1)	0.611	(1)

-
- (1) ORNL-4923, Radioactive Atoms - Supplement I, M.S. Martin, November 1973.
- (2) NEDO-12037, "Summary of Gamma and Beta Emitters and Intensity Data"; M.E. Meek, R.S. Gilbert, January 1970. (The average energy was computed from the maximum energy using the ICRP II equation, not the 1/3 value assumption used in this reference).
- (3) NCRP Report No. 58, "A Handbook of Radioactivity Measurements Procedures"; 1978
- (4) The average energy includes conversion electrons.



TABLE 2-1
 A_{in} VALUES - LIQUID*
 RADWASTE TANK
 INFANT
 $\frac{mrem - ml}{hr - \mu Ci}$

NUCLIDE	BONE	LIVER	T BODY	THYROID	KIDNEY	LUNG	GI-TRACT
H3	--	2.90E-1	2.90E-1	2.90E-1	2.90E-1	2.90E-1	2.90E-1
Cr 51	--	--	1.29E-2	8.39E-3	1.83E-3	1.63E-2	3.75E-1
Cu 64	--	1.13E-1	5.23E-2	--	1.91E-1	--	2.32
Mn 54	--	1.87E+1	4.23	--	4.14	--	6.86
FE 55	1.31E+1	8.44	2.26	--	--	4.13	1.07
Fe 59	2.84E+1	4.96E+1	1.96E+1	--	--	1.47E+1	2.37E+1
Co 58	--	3.34	8.34	--	--	--	8.33
Co 60	--	1.02E+1	2.40E+1	--	--	--	2.42E+1
Zn 65	1.72E+1	5.91E+1	2.73E+1	--	2.87E+1	--	5.00E+1
Sr 89	2.32E+3	--	6.66E+1	--	--	--	4.77E+1
Sr 90	1.74E+4	--	4.43E+3	--	--	--	2.17E+2
Zr 95	1.91E-1	4.66E-2	3.30E-2	--	5.02E-2	--	2.32E+1
Mn 56	--	2.40E-4	4.15E-5	--	2.07E-4	--	2.18E-2
Mo 99	--	2.34E+1	4.57	--	3.50E+1	--	7.71
Na 24	2.37	2.37	2.37	2.37	2.37	2.37	2.37
I 131	3.03E+1	3.54E+1	1.57E+1	1.17E+4	4.17E+1	--	1.28
I 133	4.22	6.15	1.80	1.12E+3	7.23	--	1.04
Ni 65	1.33E-3	1.51E-4	6.85E-5	--	--	--	1.15E-2
I 132	1.58E-4	3.21E-4	1.14E-4	1.50E-2	3.58E-4	--	2.60E-4
Cs 134	3.54E+2	6.60E+2	6.67E+1	--	1.70E+2	6.97E+1	1.79
Cs 136	4.05E+1	1.19E+2	4.45E+1	--	4.75E+1	9.71E+1	1.81
Cs 137	4.91E+2	5.75E+2	4.07E+1	--	1.54E+2	6.24E+1	1.80
Ba 140	1.50E+2	1.50E-1	7.74	--	3.57E-2	9.23E-2	3.69E+1
Ce 141	7.21E-2	4.40E-2	5.17E-3	--	1.36E-2	--	2.27E+1
Nb 95	3.85E-2	1.59E-2	9.18E-3	--	1.14E-2	--	1.34E+1
La 140	1.18E-2	4.67E-3	1.20E-3	--	--	--	5.48E+1
Ce 144	2.79	1.14	1.57E-1	--	4.62E-1	--	1.60E+2

* Calculated in accordance with NUREG 0133, Section 4.3.1; and Regulatory Guide 1.109, Regulatory position C, Section 1.

12 1 1 1



TABLE 2-2
 A_{LI} VALUES - LIQUID*
 RADWASTE TANK
 CHILD
 $\frac{\text{mrem} - \text{ml}}{\text{hr} - \mu\text{Ci}}$

NUCLIDE	BONE	LIVER	T BODY	THYROID	KIDNEY	LUNG	GI-TRACT
H3	--	4.39E-1	4.39E-1	4.39E-1	4.39E-1	4.39E-1	4.39E-1
Cr 51	2.13E-2	2.13E-2	1.40	7.86E-1	2.30E-1	1.42	7.31E+1
Cu 64	2.51E-6	2.70	1.63	2.51E-6	6.52	2.51E-6	1.27E+2
Mn 54	6.92	3.38E+3	9.06E+2	6.92	9.53E+2	6.92	2.84E+3
Fe 55	9.21E+2	4.88E+2	1.51E+2	--	--	2.76E+2	9.05E+1
Fe 59	1.30E+3	2.11E+3	1.05E+3	1.34	1.34	6.12E+2	2.19E+3
Co 58	1.89	7.46E+1	2.24E+2	1.89	1.89	1.89	4.26E+2
Co 60	1.12E+2	3.28E+2	7.48E+2	1.12E+2	1.12E+2	1.12E+2	1.31E+3
Zn 65	2.15E+4	5.73E+4	3.56E+4	3.85	3.61E+4	3.85	1.01E+4
Sr 89	3.26E+4	1.10E-4	9.32E+2	1.10E-4	1.10E-4	1.10E-4	1.26E+3
Sr 90	4.26E+5	--	1.08E+5	--	--	--	5.74E+3
Zr 95	1.70	1.33	1.32	1.23	1.38	1.23	1.08E+2
Mn 56	--	1.65E-1	3.73E-2	--	2.00E-1	--	2.39E+1
Mo 99	5.35E-3	9.57E+1	2.37E+1	5.35E-3	2.04E+2	5.35E-3	7.91E+1
Na 24	1.52E+2	1.52E+2	1.52E+2	1.52E+2	1.52E+2	1.52E+2	1.52E+2
I 131	2.09E+2	2.10E+2	1.19E+2	6.94E+4	3.45E+2	5.60E-2	1.87E+1
I 133	3.39E+1	4.19E+1	1.59E+1	7.78E+3	6.98E+1	1.38E-4	1.69E+1
Ni 65	2.67E-1	2.51E-2	1.47E-2	--	--	--	3.08
I 132	6.13E-3	1.13E-2	5.18E-3	5.22E-1	1.72E-2	--	1.32E-2
Cs 134	3.68E+5	6.04E+5	1.27E+5	3.54E+1	1.87E+5	6.72E+4	3.29E+3
Cs 136	3.52E+4	9.67E+4	6.26E+4	6.21E-1	5.15E+4	7.68E+3	3.40E+3
Cs 137	5.15E+5	4.93E+5	7.28E+4	5.37E+1	1.61E+5	5.78E+4	3.14E+3
Ba 140	3.61E+2	3.96E-1	2.11E+1	7.96E-2	1.82E-1	2.68E-1	1.83E+2
Ce 141	1.50E-1	1.07E-1	6.99E-2	6.34E-2	8.24E-2	6.34E-2	5.40E+1
Nb 95	5.21E+2	2.03E+2	1.45E+2	6.39E-1	1.91E+2	6.39E-1	3.75E+5
La 140	1.50E-1	5.93E-2	2.68E-2	1.03E-2	1.03E-2	1.03E-2	1.36E+3
Ce 144	5.00	1.81	6.06E-1	3.58E-1	1.16	3.58E-1	3.80E+2

* Calculated in accordance with NUREG-0133, Section 4.3.1; and Regulatory Guide 1.109, Regulatory position C, Section 1.



TABLE 2-3
 A_{int} VALUES - LIQUID*
 RADWASTE TANK
 TEEN
 $\frac{\text{mrem} - \text{ml}}{\text{hr} - \mu\text{Ci}}$

NUCLIDE	BONE	LIVER	T BODY	THYROID	KIDNEY	LUNG	GI-TRACT
H3	--	3.28E-1	3.28E-1	3.28E-1	3.28E-1	3.28E-1	3.28E-1
Cr 51	1.02E-1	1.02E-1	1.39	8.16E-1	3.84E-1	1.94	2.16E+2
Cu 64	1.20E-5	2.89	1.36	1.20E-5	7.32	1.20E-5	2.24E+2
Mn 54	3.31E+1	4.34E+3	8.87E+2	3.31E+1	1.32E+3	3.31E+1	8.86E+3
Fe 55	6.94E+2	4.92E+2	1.15E+2	--	--	3.12E+2	2.13E+2
Fe 59	1.07E+3	2.49E+3	9.64E+2	6.41	6.41	7.89E+2	5.87E+3
Co 58	9.03	9.82E+1	2.15E+2	9.03	9.03	9.03	1.24E+3
Co 60	5.36E+2	7.96E+2	1.12E+3	5.36E+2	5.36E+2	5.36E+2	3.93E+3
Zn 65	2.10E+4	7.28E+4	3.40E+4	1.84E+1	4.66E+4	1.84E+1	3.08E+4
Sr 89	2.44E+4	5.24E-4	6.98E+2	5.24E-4	5.24E-4	5.24E-4	2.90E+3
Sr 90	4.66E+5	--	1.15E+5	--	--	--	1.31E+4
Zr 95	6.20	6.00	5.97	5.90	6.04	5.90	2.28E+2
Mn 56	--	1.81E-1	3.22E-2	--	2.29E-1	--	1.19E+1
Mo 99	2.56E-2	9.22E+1	1.76E+1	2.56E-2	2.11E+2	2.56E-2	1.65E+2
Na 24	1.39E+2	1.39E+2	1.39E+2	1.39E+2	1.39E+2	1.39E+2	1.39E+2
I 131	1.55E+2	2.17E+2	1.16E+2	6.31E+4	3.73E+2	2.68E-1	4.30E+1
I 133	2.53E+1	4.29E+1	1.31E+1	5.99E+3	7.52E+1	6.60E-4	3.25E+1
Ni 65	2.08E-1	2.66E-2	1.21E-2	--	--	--	1.44
I 132	4.90E-2	1.28E-2	4.60E-3	4.32E-1	2.02E-2	--	5.59E-3
Cs 134	3.05E+5	7.18E+5	3.33E+5	1.69E+2	2.28E+5	8.73E+4	9.10E+3
Cs 136	2.98E+4	1.17E+5	7.88E+4	2.97	6.38E+4	1.01E+4	9.44E+3
Cs 137	4.09E+5	5.44E+5	1.90E+5	2.57E+2	1.85E+5	7.21E+4	7.99E+3
Ba 140	2.35E+2	4.10E-1	1.55E+1	3.81E-1	4.79E-1	5.75E-1	3.63E+2
Ce 141	3.46E-1	3.32E-1	3.07E-1	3.04E-1	3.17E-1	3.04E-1	8.16E+1
Nb 95	4.44E+2	2.48E+2	1.18E+2	3.06	2.40E+2	3.06	1.05E+6
La 140	1.57E-1	1.02E-1	6.35E-2	4.94E-2	4.94E-2	4.94E-2	3.05E+3
Ce 144	3.99	2.65	1.83	1.71	2.27	1.71	5.74E+2

* Calculated in accordance with NUREG 0133, Section 4.3.1; and Regulatory Guide 1.109, Regulatory position C, Section 1.



TABLE 2-4
 A_{int} VALUES - LIQUID*
 RADWASTE TANK
 ADULT
 $\frac{\text{mrem} - \text{ml}}{\text{hr} - \mu\text{Ci}}$

NUCLIDE	BONE	LIVER	T BODY	THYROID	KIDNEY	LUNG	GI-TRACT
H3	--	4.45E-1	4.45E-1	4.45E-1	4.45E-1	4.45E-1	4.45E-1
Cr 51	1.82E-2	1-82E-2	1.27	7.64E-1	2.93E-1	1.67	3.14E+2
Cu 64	--	2.75	1.29	--	6.94	--	2.35E+2
Mn 54	5.94	4.38E+3	8.41E+2	5.94	1.31E+3	5.94	1.34E+4
Fe 55	6.64E+2	4.58E+2	1.07E+2	--	--	2.56E+2	2.63E+2
Fe 59	1.03E+3	2.43E+3	9.31E+2	1.15	1.15	6.79E+2	8.09E+3
Co 58	1.62	9.15E+1	2.03E+2	1.62	1.62	1.62	1.82E+3
Co 60	9.60E+1	2.57E+2	6.71E+2	9.60E+1	9.60E+1	9.60E+1	4.99E+3
Zn 65	2.31E4	7.36E+4	3.32E+4	3.30	4.92E+4	3.30	4.63E+4
Sr 89	2.25E+4	9.39E-5	6.45E+2	9.39E-5	9.39E-5	9.39E-5	3.60E+3
Sr 90	5.60E+5	--	1.37E+5	--	--	--	1.62E+4
Zr 95	1.36	1.15E	1.12	1.06	1.21	1.06	3.06E+2
Mn 56	--	1.73E-1	3.07E-2	--	2.20E-1	--	5.52
Mo 99	4.58E-3	8.70E+1	1.66E+1	4.58E-3	1.97E+2	4-58E-3	2.02E+2
Na 24	1.35E+2	1.35E+2	1.35E+2	1.35E+2	1.35E+2	1.35E+2	1.35E+2
I 131	1.45E+2	2.07E+2	1.19E+2	6.79E+4	3.55E+2	4.80E-2	5.47E+1
I 133	2.35E+1	4.09E+1	1.25E+1	6.02E+3	7.14E+1	1.18E-4	3.68E+1
Ni 65	1.93E-1	2.51E-2	1.14E-2	--	--	--	6.36E-1
I 132	4.68E-3	1.25E-2	4.38E-3	4.38E-1	2.00E-2	--	2.35E-3
Cs 134	2.98E+5	7.08E+5	5.79E+5	3.03E+1	2.29E+5	7.61E+4	1.24E+4
Cs 136	2.96E+4	1.17E+5	8.42E+4	5.32E-1	6.51E+4	8.93E+3	1.33E+4
Cs 137	3.82E+5	5.22E+5	3.42E+5	4.60E+1	1.77E+5	5.90E+4	1.02E+4
Ba 140	2.24E+2	3.49E-1	1.47E+1	6.83E-2	1.64E-1	2.29E-1	4.61E+2
Ce 141	9.53E-2	8.20E-2	5.75E-2	5.44E-2	6.72E-2	5.44E-2	1.06E+2
Nb 95	4.39E+2	2.44E+2	1.32E+2	5.47E-1	2.41E+2	5.47E-1	1.48E+6
La 140	1.11E-1	6.03E-2	2.24E-2	8.84E-3	8.84E-3	8.84E-3	3.78E+3
Ce 144	2.48	1.22	4.24E-1	3.07E-1	8.47E-1	3.07E-1	7.37E+2

* Calculated in accordance with NUREG 0133, Section 4.3.1; and Regulatory Guide 1.109, Regulatory position C, Section 1.



TABLE 2-5
 A_{int} VALUES - LIQUID*
 EMERGENCY CONDENSER VENT
 INFANT
 $\frac{mrem - ml}{hr} = \mu Ci$

NUCLIDE	BONE	LIVER	T BODY	THYROID	KIDNEY	LUNG	GI-TRACT
H3	--	7.43E-4	7.43E-4	7.43E-4	7.43E-4	7.43E-4	7.43E-4
Cr 51	--	--	3.30E-5	2.15E-5	4.70E-6	4.18E-5	9.61E-4
Cu 64	--	2.89E-4	1.34E-4	--	4.89E-4	--	5.94E-3
Mn 54	--	4.79E-2	1.08E-2	--	1.06E-2	--	1.76E-2
Fe 55	3.35E-2	2.16E-2	5.78E-3	--	--	1.06E-2	2.75E-3
Fe 59	7.29E-2	1.27E-1	5.02E-2	--	--	3.76E-2	6.08E-2
Co 58	--	8.58E-3	2.14E-2	--	--	--	2.14E-2
Co 60	--	2.60E-2	6.15E-2	--	--	--	6.19E-2
Zn 65	4.42E-2	1.52E-1	6.99E-2	--	7.35E-2	--	1.28E-1
Sr 89	5.95	--	1.71E-1	--	--	--	1.22E-1
Sr 90	4.46E+1	--	1.14E+1	--	--	--	5.57E-1
Zr 95	4.90E-4	1.19E-4	8.47E-5	--	1.29E-4	--	5.95E-2
Mn 56	--	6.17E-7	1.06E-7	--	5.30E-7	--	5.60E-5
Mo 99	--	6.00E-2	1.17E-2	--	8.97E-2	--	1.98E-2
Na 24	6.07E-3	6.07E-3	6.07E-3	6.07E-3	6.07E-3	6.07E-3	6.07E-3
I 131	7.77E-2	9.16E-2	4.03E-2	3.01E+1	1.07E-1	--	3.27E-3
I 133	1.08E-2	1.58E-2	4.62E-3	2.87	1.85E-2	--	2.67E-3
Ni 65	3.41E-6	3.86E-7	1.76E-7	--	--	--	2.94E-5
I 132	4.05E-7	8.22E-7	2.93E-7	3.85E-5	9.17E-7	--	6.66E-7
Cs 134	9.08E-1	1.69	1.71E-1	--	4.36E-1	1.79E-1	4.60E-3
Cs 136	1.04E-1	3.06E-1	1.14E-1	--	1.22E-1	2.49E-2	4.64E-3
Cs 137	1.26	1.47	1.04E-1	--	3.95E-1	1.60E-1	4.61E-3
Ba 140	3.85E-1	3.85E-4	1.99E-2	--	9.15E-5	2.37E-4	9.47E-2
Ce 141	1.85E-4	1.13E-4	1.33E-5	--	3.48E-5	--	5.82E-2
Nb 95	9.88E-5	4.07E-5	2.35E-5	--	2.92E-5	--	3.43E-2
La 140	3.03E-5	1.20E-5	3.08E-6	--	--	--	1.41E-1
Ce 144	7.16E-3	2.93E-3	4.02E-4	--	1.19E-3	--	4.11E-1

* Calculated in accordance with NUREG 0133, Section 4.3.1; and Regulatory Guide 1.109, Regulatory position C, Section 1.



TABLE 2-6
 A_{in} VALUES - LIQUID*
 EMERGENCY CONDENSER VENT
 CHILD
 $\frac{mrem - ml}{hr - \mu Ci}$

NUCLIDE	BONE	LIVER	T BODY	THYROID	KIDNEY	LUNG	GI-TRACT
H3	--	1.44E-1	1.44E-1	1.44E-1	1.44E-1	1.44E-1	1.44E-1
Cr 51	3.78E-5	3.78E-5	1.37	7.58E-1	2.07E-1	1.38	7.24E+1
Cu 64	--	2.63	1.59	--	6.35	--	1.23E+2
Mn 54	1.23E-2	3.36E+3	8.95E+2	1.23E-2	9.42E+2	1.23E-2	2.82E+3
Fe 55	9.04E+2	4.79E+2	1.49E+2	--	--	2.71E+2	8.88E+1
Fe 59	1.28E+3	2.07E+3	1.03E+3	2.38E-3	2.38E-3	6.00E+2	2.15E+3
Co 58	3.36E-3	7.01E+1	2.15E+2	3.36E-3	3.36E-3	3.36E-3	4.09E+2
Co 60	1.99E-1	2.08E+2	6.14E+2	1.99E-1	1.99E-1	1.99E-1	1.15E+3
Zn 65	2.15E+4	5.73E+4	3.56E+4	6.84E-3	3.61E+4	6.84E-3	1.01E+4
Sr 89	3.07E+4	--	8.78E+2	--	--	--	1.19E+3
Sr 90	4.01E+5	--	1.02E+5	--	--	--	5.40E+3
Zr 95	3.01E-1	6.78E-2	6.06E-2	2.19E-3	9.61E-2	2.19E-3	6.84E+1
Mn 56	--	1.65E-1	3.73E-2	--	2.00E-1	--	2.39E+1
Mo 99	--	8.16E+1	2.02E+1	--	1.74E+2	--	6.75E+1
Na 24	1.50E+2	1.50E+2	1.50E+2	1.50E+2	1.50E+2	1.50E+2	1.50E+2
I 131	1.86E+2	1.87E+2	1.06E+2	6.19E+4	3.08E+2	--	1.67E+1
I 133	3.08E+1	3.81E+1	1.44E+1	7.07E+3	6.35E+1	--	1.53E+1
Ni 65	2.66E-1	2.50E-2	1.46E-2	--	--	--	3.07
I 132	6.01E-3	1.10E-2	5.08E-3	5.12E-1	1.69E-2	--	1.30E-2
Cs 134	3.68E+5	6.04E+5	1.27E+5	6.29E-2	1.87E+5	6.71E+4	3.25E+3
Cs 136	3.51E+4	9.66E+4	6.25E+4	1.10E-3	5.14E+4	7.67E+3	3.40E+3
Cs 137	5.14E+5	4.92E+5	7.27E+4	9.55E-2	1.60E+5	5.77E+4	3.08E+3
Ba 140	2.48E+2	2.17E-1	1.45E+1	1.42E-4	7.09E-2	1.30E-1	1.26E+2
Ce 141	3.08E-2	1.54E-2	2.39E-3	1.13E-4	6.83E-3	1.13E-4	1.91E+1
Nb 95	5.21E+2	2.03E+2	1.45E+2	1.14E-3	1.90E+2	1.14E-3	3.75E+5
La 140	1.31E-1	4.59E-2	1.55E-2	1.83E-5	1.83E-5	1.83E-5	1.28E+3
Ce 144	1.64	5.15E-1	8.81E-2	6.36E-4	2.85E-1	6.36E-4	1.34E+2

* Calculated in accordance with NUREG 0133, Section 4.3.1; and Regulatory Guide 1.109, Regulatory position C, Section 1.

2
.
51
82



TABLE 2-7
 A_{int} VALUES - LIQUID*
 EMERGENCY CONDENSER VENT
 TEEN
 $\frac{mrem - ml}{hr - \mu Ci}$

NUCLIDE	BONE	LIVER	T BODY	THYROID	KIDNEY	LUNG	GI-TRACT
H3	--	1.74E-1	1.74E-1	1.74E-1	1.74E-1	1.74E-1	1.74E-1
Cr 51	1.81E-4	1.81E-4	1.28	7.12E-1	2.81E-1	1.83	2.15E+2
Cu 64	--	2.86	1.35	--	7.24	--	2.22E+2
Mn 54	5.89E-2	4.29E+3	8.52E+2	5.89E-2	1.28E+3	5.89E-2	8.81E+3
Fe 55	6.89E+2	4.88E+2	1.14E+2	--	--	3.10E+2	2.11E+2
Fe 59	1.05E+3	2.46E+3	9.50E+2	1.14E-2	1.14E-2	7.76E2	5.82E+3
Co 58	1.61E-2	8.78E+1	2.02E+2	1.61E-2	1.61E-2	1.61E-2	1.21E+3
Co 60	9.53E-1	2.57E+2	5.78E+2	9.53E-1	9.53E-1	9.53E-1	3.34E+3
Zn 65	2.10E+4	7.28E+4	3.39E+4	3.28E-2	4.66E+4	3.28E-2	3.08E+4
Sr 89	2.38E+4	--	6.81E+2	--	--	--	2.83E+3
Sr 90	4.54E+5	--	1.12E+5	--	--	--	1.27E+4
Zr 95	2.56E-1	8.80E-2	6.38E-2	1.05E-2	1.24E-1	1.05E-2	1.79E+2
Mn 56	--	1.81E-1	3.22E-2	--	2.29E-1	--	1.19E+1
Mo 99	--	8.57E+1	1.63E+1	--	1.96E+2	--	1.54E+2
Na 24	1.38E+2	1.38E+2	1.38E+2	1.38E+2	1.38E+2	1.38E+2	1.38E+2
I 131	1.47E+2	2.06E+2	1.10E+2	6.00E+4	3.54E+2	4.77E-4	4.07E+1
I 133	2.42E+1	4.11E+1	1.25E+1	5.74E+3	7.21E+1	--	3.11E+1
Ni 65	2.08E-1	2.66E-2	1.21E-2	--	--	--	1.44
I 132	4.86E-3	1.27E-2	4.56E-3	4.29E-1	2.00E-2	--	5.54E-3
Cs 134	3.05E+5	7.18E+5	3.33E+5	3.01E-1	2.28E+5	8.71E+4	8.93E+3
Cs 136	2.98E+4	1.17E+5	7.87E+4	5.28E-3	6.38E+4	1.01E+4	9.43E+3
Cs 137	4.09E+5	5.44E+5	1.89E+5	4.57E-1	1.85E+5	7.19E+4	7.73E+3
Ba 140	1.96E+2	2.47E-2	1.27E+1	6.77E-4	8.23E-2	1.62E-1	3.03E+2
Ce 141	2.43E-2	1.64E-2	2.36E-3	5.40E-4	8.02E-3	5.40E-4	4.54E+1
Nb 95	4.41E+2	2.45E+2	1.15E+2	5.43E-3	2.37E+2	5.43E-3	1.05E+6
La 140	1.05E-1	5.17E-2	1.38E-2	8.78E-5	8.78E-5	8.78E-5	2.96E+3
Ce 144	1.27	5.28E-1	7.12E-2	3.04E-3	3.17E-1	3.04E-3	3.19E+2

* Calculated in accordance with NUREG 0133, Section 4.3.1; and Regulatory Guide 1.109, Regulatory position C, Section 1.



TABLE 2-8
 A_{int} VALUES - LIQUID*
 EMERGENCY CONDENSER VENT
 ADULT
 $\frac{\text{mrem} - \text{ml}}{\text{hr} - \mu\text{Ci}}$

NUCLIDE	BONE	LIVER	T BODY	THYROID	KIDNEY	LUNG	GI-TRACT
H3	--	2.27E-1	2.27E-1	2.27E-1	2.27E-1	2.27E-1	2.27E-1
Cr 51	3.24E-5	3.24E-5	1.24	7.43E-1	2.74E-1	1.65	3.12E+2
Cu 64	--	2.72	1.28	--	6.86	--	2.32E+2
Mn 54	1.06E-2	4.37E+3	8.33E+2	1.06E-2	1.30E+3	1.06E-2	1.34E+4
Fe 55	6.58E+2	4.55E+2	1.06E+2	--	--	2.54E+2	2.61E+2
Fe 59	1.02E+3	2.41E+3	9.22E+2	2.04E-3	2.04E-3	6.72E+2	8.02E+3
Co 58	2.88E-3	8.83E+1	1.98E+2	2.88E-3	2.88E-3	2.88E-3	1.79E+3
Co 60	1.71E-1	2.56E+2	5.65E+2	1.71E-1	1.71E-1	1.71E-1	4.81E+3
Zn 65	2.31E+4	7.36E+4	3.32E+4	5.87E-3	4.92E+4	5.87E-3	4.63E+4
Sr 89	2.18E+4	--	6.27E+2	--	--	--	3.50E+3
Sr 90	5.44E+5	--	1.34E+5	--	--	--	1.57E+4
Zr 95	2.40E-1	7.81E-2	5.35E-2	1.88E-3	1.22E-1	1.88E-3	2.42E+2
Mn 56	--	1.73E-1	3.07E-2	--	2.20E-1	--	5.52
Mo 99	--	8.04E+1	1.53E+1	--	1.82E+2	--	1.86E+2
Na 24	1.34E+2	1.34E+2	1.34E+2	1.34E+2	1.34E+2	1.34E+2	1.34E+2
I 131	1.37E+2	1.96E+2	1.12E+2	6.43E+4	3.36E+2	--	5.17E+1
I 133	2.25E+1	3.91E+1	1.19E+1	5.75E+3	6.82E+1	--	3.51E+1
Ni 65	1.93E-1	2.50E-2	1.14E-2	--	--	--	6.36E-1
I 132	4.64E-3	1.24E-2	4.34E-3	4.34E-1	1.98E-2	--	2.33E-3
Cs 134	2.98E+5	7.08E+5	5.79E+5	5.39E-2	2.29E+5	7.61E+4	1.24E+4
Cs 136	2.96E+4	1.17E+5	8.42E+4	9.46E-4	6.51E+4	8.92E+3	1.33E+4
Cs 137	3.82E+5	5.22E+5	3.42E+5	8.19E-2	1.77E+5	5.89E+4	1.01E+4
Ba 140	1.84E+2	2.32E-1	1.21E+1	1.21E-4	7.88E-2	1.33E-1	3.79E+2
Ce 141	2.21E-2	1.50E-2	1.78E-3	9.67E-5	7.00E-3	9.67E-5	5.68E+1
Nb 95	4.38E+2	2.44E+2	1.31E+2	9.73E-4	2.41E+2	9.73E-4	1.48E+6
La 140	9.90E-2	4.99E-2	1.32E-2	1.57E-5	1.57E-5	1.57E-5	3.66E+3
Ce 144	1.17	4.89E-1	6.33E-2	5.45E-4	2.90E-1	5.45E-4	3.95E+2

* Calculated in accordance with NUREG 0133, Section 4.3.1; and Regulatory Guide 1.109, Regulatory position C, Section 1.



TABLE 3-1
Critical Receptor Dispersion Parameters^a
For Ground Level and Elevated Releases

<u>LOCATION</u>	<u>DIR</u>	<u>MILES</u>	<u>ELEVATED</u>		<u>GROUND^e</u>	
			<u>X/Q (sec/m³)</u>	<u>D/Q (m²)</u>	<u>X/Q(sec/m³)</u>	<u>D/Q (m²)</u>
Residences	E (98°)	1.4	1.8 E-07 ^b	5.2 E-09 ^b	4.02 E-07	8.58 E-09
Dairy Cows ^f	SE (130°)	2.6	2.2 E-08 ^c	7.0 E-10 ^c	6.00 E-08	1.64 E-09
Milk Goats ^f	SE (130°)	2.6	2.2 E-08 ^c	7.0 E-10 ^c	6.00 E-08	1.64 E-09
Meat Animals	ESE (115°)	1.8	5.1 E-08 ^c	1.7 E-09 ^c	1.16 E-07	3.54 E-09
Gardens	E (97°)	1.8	1.0 E-07 ^c	3.5 E-09 ^c	2.53 E-07	5.55 E-09
Site Boundary	ENE (67°)	0.4	2.4 E-06 ^{b,d}	4.4 E-08 ^{c,d}	6.63 E-06	6.35 E-08

- a. These values will be used in dose calculations beginning in April 1986 but may be revised periodically to account for changes in locations of farms, gardens or critical residences.
- b. Values based on 5 year annual meteorological data (C.T. Main, Rev. 2)
- c. Values based on 5 year average grazing season meteorological data (C.T. Main Rev. 2)
- d. Value are based on most restrictive X/Q land-based sector (ENE). (C.T. Main, Rev. 2)
- e. Values are based on average annual meteorological data for the year 1985.
- f. Conservative location based on past dairy cow and goat milk history.

10
11
12
13
14



TABLE 3-2

Gamma Air and Whole Body Plume Shine Dose Factors*
For
Noble Gases

<u>Nuclide</u>	<u>Gamma Air B_i</u> <u>mrad/yr</u> <u>μCi/sec</u>	<u>Gamma Whole</u> <u>Body V_i</u> <u>mrem/yr</u> <u>μCi/sec</u>
Kr-85	2.23E-6	--
Kr-85m	1.75E-3	1.68E-3
Kr-87	1.02E-2	9.65E-3
Kr-88	2.23E-2	2.17E-2
Kr-89	2.50E-2	1.71E-2
Kr-83m	2.26E-6	--
Xe-133	2.80E-4	2.41E-4
Xe-133m	2.27E-4	1.87E-4
Xe-135	2.62E-3	2.50E-3
Xe-135m	5.20E-3	4.89E-3
Xe-137	2.30E-3	2.20E-3
Xe-138	1.32E-2	1.26E-2
Xe-131m	1.74E-5	1.47E-6
Ar-41	1.64E-2	1.57E-2

* Calculated in accordance with Regulatory Guide 1.109. (See Appendix B.)



TABLE 3-3

IMMERSION DOSE FACTORS*

<u>Nuclide</u>	<u>K_i(γ-Body)**</u>	<u>L_i(β-Skin)**</u>	<u>M_i(γ-Air)***</u>	<u>N_i(β-Air)***</u>
Kr 83m	7.56E-02	---	1.93E1	2.88E2
Kr 85m	1.17E3	1.46E3	1.23E3	1.97E3
Kr 85	1.61E1	1.34E3	1.72E1	1.95E3
Kr 87	5.92E3	9.73E3	6.17E3	1.03E4
Kr 88	1.47E4	2.37E3	1.52E4	2.93E3
Kr 89	1.66E4	1.01E4	1.73E4	1.06E4
Kr 90	1.56E4	7.29E3	1.63E4	7.83E3
Xe 131m	9.15E1	4.76E2	1.56E2	1.11E3
Xe 133m	2.51E2	9.94E2	3.27E2	1.48E3
Xe 133	2.94E2	3.06E2	3.53E2	1.05E3
Xe 135m	3.12E3	7.11E2	3.36E3	7.39E2
Xe 135	1.81E3	1.86E3	1.92E3	2.46E3
Xe 137	1.42E3	1.22E4	1.51E3	1.27E4
Xe 138	8.83E3	4.13E3	9.21E3	4.75E3
Ar 41	8.84E3	2.69E3	9.30E3	3.28E3

* From, Table B-1. Regulatory Guide 1.109 Rev. 1

** mrem/yr per $\mu\text{Ci}/\text{m}^3$.

*** mrad/yr per $\mu\text{Ci}/\text{m}^3$.



TABLE 3-4
DOSE AND DOSE RATE
R_i VALUES - INHALATION - INFANT¹
 $\frac{\text{mrem/yr}}{\mu\text{Ci/m}^3}$

<u>NUCLIDE</u>	<u>BONE</u>	<u>LIVER</u>	<u>T. BODY</u>	<u>THYROID</u>	<u>KIDNEY</u>	<u>LUNG</u>	<u>GI-LLI</u>
H 3*	--	6.47E2	6.47E2	6.47E2	6.47E2	6.47E2	6.47E2
C 14*	2.65E4	5.31E3	5.31E3	5.31E3	5.31E3	5.31E3	5.31E3
Cr 51	--	--	8.95E1	5.75E1	1.32E1	1.28E4	3.57E2
Mn 54	--	2.53E4	4.98E3	--	4.98E3	1.00E6	7.06E3
Fe 55	1.97E4	1.17E4	3.33E3	--	--	8.69E4	1.09E3
Fe 59	1.36E4	2.35E4	9.48E3	--	--	1.02E6	2.48E4
Co 58	--	1.22E3	1.82E3	--	--	7.77E5	1.11E4
Co 60	--	8.02E3	1.18E4	--	--	4.51E6	3.19E4
Zn 65	1.93E4	6.26E4	3.11E4	--	3.25E4	6.47E5	5.14E4
Sr 89	3.98E5	--	1.14E4	--	--	2.03E6	6.40E4
Sr 90	4.09E7	--	2.59E6	--	--	1.12E7	1.31E5
Zr 95	1.15E5	2.79E4	2.03E4	--	3.11E4	1.75E6	2.17E4
Nb 95	1.57E4	6.43E3	3.78E3	--	4.72E3	4.79E5	1.27E4
Mo 99	--	1.65E2	3.23E1	--	2.65E2	1.35E5	4.87E4
I-131	3.79E4	4.44E4	1.96E4	1.48E7	5.18E4	--	1.06E3
I 133	1.32E4	1.92E4	5.60E3	3.56E6	2.24E4	--	2.16E3
Cs 134	3.96E5	7.03E5	7.45E4	--	1.90E5	7.97E4	1.33E3
Cs 137	5.49E5	6.12E5	4.55E4	--	1.72E5	7.13E4	1.33E3
Ba 140	5.60E4	5.60E1	2.90E3	--	1.34E1	1.60E6	3.84E4
La 140	5.05E2	2.00E2	5.15E1	--	--	1.68E5	8.48E4
Ce 141	2.77E4	1.67E4	1.99E3	--	5.25E3	5.17E5	2.16E4
Ce 144	3.19E6	1.21E6	1.76E5	--	5.38E5	9.84E6	1.48E5
Nd 147	7.94E3	8.13E3	5.00E2	--	3.15E3	3.22E5	3.12E4

* mrem/yr per $\mu\text{Ci/m}^3$.

¹This and following R_i Tables Calculated in accordance with NUREG 0133, Section 5.3.1, except C 14 values in accordance with Regulatory Guide 1.109 Equation C-8.



TABLE 3-5
DOSE AND DOSE RATE
R_i VALUES - INHALATION - CHILD
 $\frac{\text{mrem/yr}}{\mu\text{Ci/m}^3}$

<u>NUCLIDE</u>	<u>BONE</u>	<u>LIVER</u>	<u>T. BODY</u>	<u>THYROID</u>	<u>KIDNEY</u>	<u>LUNG</u>	<u>GI-LLI</u>
H 3*	--	1.12E3	1.12E3	1.12E3	1.12E3	1.12E3	1.12E3
C 14*	3.59E4	6.73E3	6.73E3	6.73E3	6.73E3	6.73E3	6.73E3
Cr 51	--	--	1.54E2	8.55E1	2.43E1	1.70E4	1.08E3
Mn 54	--	4.29E4	9.51E3	--	1.00E4	1.58E6	2.29E4
Fe 55	4.74E4	2.52E4	7.77E3	--	--	1.11E5	2.87E3
Fe 59	2.07E4	3.34E4	1.67E4	--	--	1.27E6	7.07E4
Co 58	--	1.77E3	3.16E3	--	--	1.11E6	3.44E4
Co 60	--	1.31E4	2.26E4	--	--	7.07E6	9.62E4
Zn 65	4.26E4	1.13E5	7.03E4	--	7.14E4	9.95E5	1.63E4
Sr 89	5.99E5	--	1.72E4	--	--	2.16E6	1.67E5
Sr 90	1.01E8	--	6.44E6	--	--	1.48E7	3.43E5
Zr 95	1.90E5	4.18E4	3.70E4	--	5.96E4	2.23E6	6.11E4
Nb 95	2.35E4	9.18E3	6.55E3	--	8.62E3	6.14E5	3.70E4
Mo 99	--	1.72E2	4.26E1	--	3.92E2	1.35E5	1.27E5
I 131	4.81E4	4.81E4	2.73E4	1.62E7	7.88E4	--	2.84E3
I 133	1.66E4	2.03E4	7.70E3	3.85E6	3.38E4	--	5.48E3
Cs 134	6.51E5	1.01E6	2.25E5	--	3.30E5	1.21E5	3.85E3
Cs 137	9.07E5	8.25E5	1.28E5	--	2.82E5	1.04E5	3.62E3
Ba 140	7.40E4	6.48E1	4.33E3	--	2.11E1	1.74E6	1.02E5
La 140	6.44E2	2.25E2	7.55E1	--	--	1.83E5	2.26E5
Ce 141	3.92E4	1.95E4	2.90E3	--	8.55E3	5.44E5	5.66E4
Ce 144	6.77E6	2.12E6	3.61E5	--	1.17E6	1.20E7	3.89E5
Nd 147	1.08E4	8.73E3	6.81E2	--	4.81E3	3.28E5	8.21E4

* mrem/yr per $\mu\text{Ci/m}^3$.

TABLE 3-6
DOSE AND DOSE RATE
R₁ VALUES - INHALATION - TEEN
 $\frac{\text{mrem/yr}}{\mu\text{Ci/m}^3}$

NUCLIDE	BONE	LIVER	T. BODY	THYROID	KIDNEY	LUNG	GI-LLI
H 3*	--	1.27E3	1.27E3	1.27E3	1.27E3	1.27E3	1.27E3
C 14*	2.60E4	4.87E3	4.87E3	4.87E3	4.87E3	4.87E3	4.87E3
Cr 51	--	--	1.35E2	7.50E1	3.07E1	2.10E4	3.00E3
Mn 54	--	5.11E4	8.40E3	--	1.27E4	1.98E6	6.68E4
Fe 55	3.34E4	2.38E4	5.54E3	--	--	1.24E5	6.39E3
Fe 59	1.59E4	3.70E4	1.43E4	--	--	1.53E6	1.78E5
Co 58	--	2.07E3	2.78E3	--	--	1.34E6	9.52E4
Co 60	--	1.51E4	1.98E4	--	--	8.72E6	2.59E5
Zn 65	3.86E4	1.34E5	6.24E4	--	8.64E4	1.24E6	4.66E4
Sr 89	4.34E5	--	1.25E4	--	--	2.42E6	3.71E5
Sr 90	1.08E8	--	6.68E6	--	--	1.65E7	7.65E5
Zr 95	1.46E5	4.58E4	3.15E4	--	6.74E4	2.69E6	1.49E5
Nb 95	1.86E4	1.03E4	5.66E3	--	1.00E4	7.51E5	9.68E4
Mo 99	--	1.69E2	3.22E1	--	4.11E2	1.54E5	2.69E5
I 131	3.54E4	4.91E4	2.64E4	1.46E7	8.40E4	--	6.49E3
I 133	1.22E4	2.05E4	6.22E3	2.92E6	3.59E4	--	1.03E4
Cs 134	5.02E5	1.13E6	5.49E5	--	3.75E5	1.46E5	9.76E3
Cs 137	6.70E5	8.48E5	3.11E5	--	3.04E5	1.21E5	8.48E3
Ba 140	5.47E4	6.70E1	3.52E3	--	2.28E1	2.03E6	2.29E5
La 140	4.79E2	2.36E2	6.26E1	--	--	2.14E5	4.87E5
Ce 141	2.84E4	1.90E4	2.17E3	--	8.88E3	6.14E5	1.26E5
Ce 144	4.89E6	2.02E6	2.62E5	--	1.21E6	1.34E7	8.64E5
Nd 147	7.86E3	8.56E3	5.13E2	--	5.02E3	3.72E5	1.82E5

* mrem/yr per $\mu\text{Ci/m}^3$.

10
11
12



TABLE 3-7
DOSE AND DOSE RATE
R₁ VALUES - INHALATION - ADULT
 $\frac{\text{mrem/yr}}{\mu\text{Ci/m}^3}$

<u>NUCLIDE</u>	<u>BONE</u>	<u>LIVER</u>	<u>T. BODY</u>	<u>THYROID</u>	<u>KIDNEY</u>	<u>LUNG</u>	<u>GI-LLI</u>
H 3*	--	1.26E3	1.26E3	1.26E3	1.26E3	1.26E3	1.26E3
C 14*	1.82E4	3.41E3	3.41E3	3.41E3	3.41E3	3.41E3	3.41E3
Cr 51	--	--	1.00E2	5.95E1	2.28E1	1.44E4	3.32E3
Mn 54	--	3.96E4	6.30E3	--	9.84E3	1.40E6	7.74E4
Fe 55	2.46E4	1.70E4	3.94E3	--	--	7.21E4	6.03E3
Fe 59	1.18E4	2.78E4	1.06E4	--	--	1.02E6	1.88E5
Co 58	--	1.58E3	2.07E3	--	--	9.28E5	1.06E5
Co 60	--	1.15E4	1.48E4	--	--	5.97E6	2.85E5
Zn 65	3.24E4	1.03E5	4.66E4	--	6.90E4	8.64E5	5.34E4
Sr 89	3.04E5	--	8.72E3	--	--	1.40E6	3.50E5
Sr 90	9.92E7	--	6.10E6	--	--	9.60E6	7.22E5
Zr 95	1.07E5	3.44E4	2.33E4	--	5.42E4	1.77E6	1.50E5
Nb 95	1.41E4	7.82E3	4.21E3	--	7.74E3	5.05E5	1.04E5
Mo 99	--	1.21E2	2.30E1	--	2.91E2	9.12E4	2.48E5
I 131	2.52E4	3.58E4	2.05E4	1.19E7	6.13E4	--	6.28E3
I 133	8.64E3	1.48E4	4.52E3	2.15E6	2.58E4	--	8.88E3
Cs 134	3.73E5	8.48E5	7.28E5	--	2.87E5	9.76E4	1.04E4
Cs 137	4.78E5	6.21E5	4.28E5	--	2.22E5	7.52E4	8.40E3
Ba 140	3.90E4	4.90E1	2.57E3	--	1.67E1	1.27E6	2.18E5
La 140	3.44E2	1.74E2	4.58E1	--	--	1.36E5	4.58E5
Ce 141	1.99E4	1.35E4	1.53E3	--	6.26E3	3.62E5	1.20E5
Ce 144	3.43E6	1.43E6	1.84E5	--	8.48E5	7.78E6	8.16E5
Nd 147	5.27E3	6.10E3	3.65E2	--	3.56E3	2.21E5	1.73E5

* mrem/yr per $\mu\text{Ci/m}^3$.

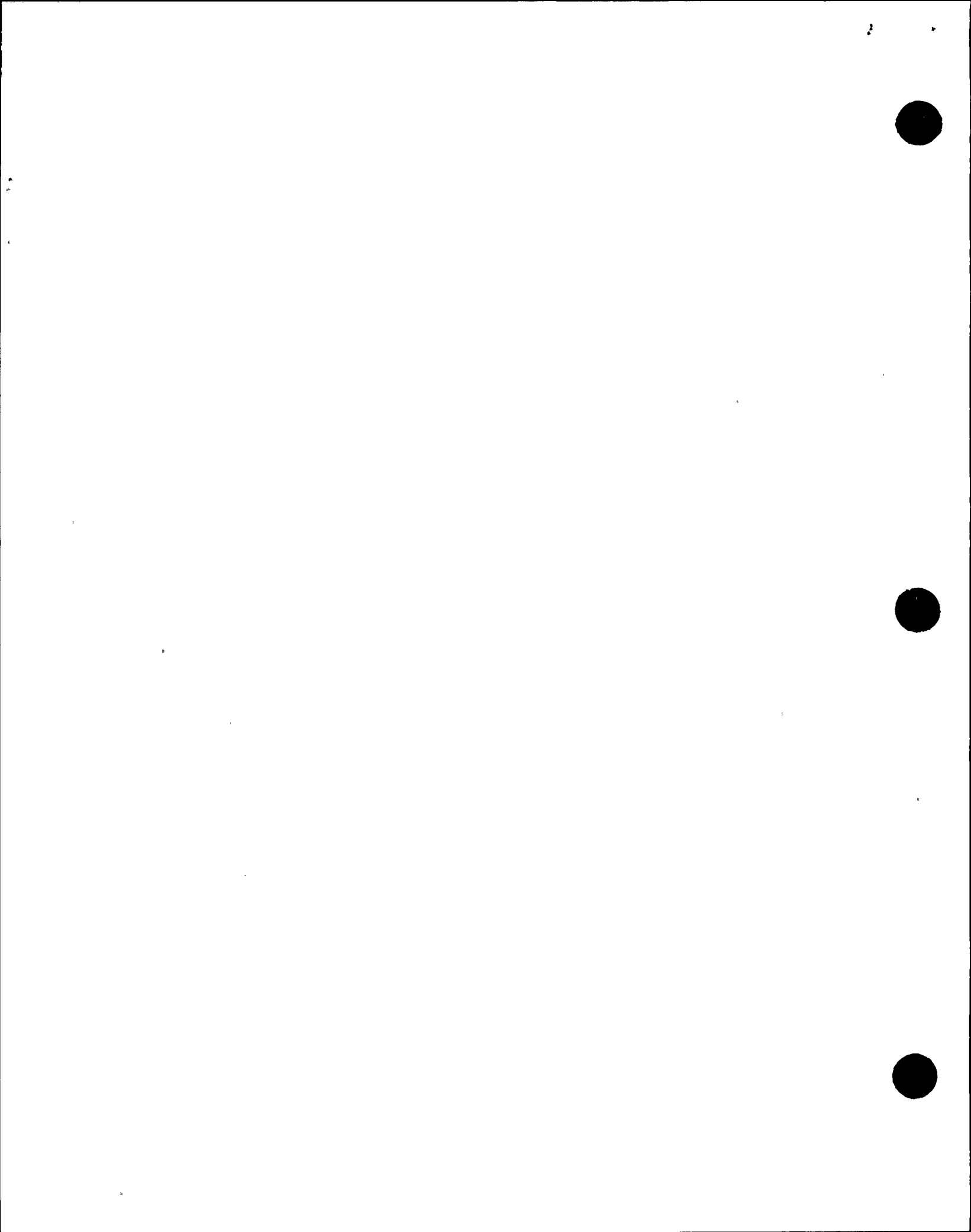

TABLE 3-8
DOSE AND DOSE RATE
R₁ VALUES - GROUND PLANE
ALL AGE GROUPS
 $\frac{m^2 \cdot mrem}{yr}$
 $\mu Ci/sec$

<u>NUCLIDE</u>	<u>TOTAL BODY</u>	<u>SKIN</u>
H 3	--	--
C 14	--	--
Cr 51	4.65E6	5.50E6
Mn 54	1.40E9	1.64E9
Fe 55	--	--
Fe 59	2.73E8	3.20E8
Co 58	3.80E8	4.45E8
Co 60	2.15E10	2.53E10
Zn 65	7.46E8	8.57E8
Sr 89	2.16E4	2.51E4
Sr 90	--	--
Zr 95	2.45E8	2.85E8
Nb 95	1.36E8	1.61E8
Mo 99	3.99E6	4.63E6
I 131	1.72E7	2.09E7
I 133	2.39E6	2.91E6
Cs 134	6.83E9	7.97E9
Cs 137	1.03E10	1.20E10
Ba 140	2.05E7	2.35E7
La 140	1.92E7	2.18E7
Ce 141	1.37E7	1.54E7
Ce 144	6.96E7	8.07E7
Nd 147	8.46E6	1.01E7



TABLE 3-9
DOSE AND DOSE RATE
R₁ VALUES - COW MILK - INFANT
 $\frac{m^2 \cdot mrem/yr}{\mu Ci/sec}$

<u>NUCLIDE</u>	<u>BONE</u>	<u>LIVER</u>	<u>T. BODY</u>	<u>THYROID</u>	<u>KIDNEY</u>	<u>LUNG</u>	<u>GI-LLI</u>
H 3	--	2.38E3	2.38E3	2.38E3	2.38E3	2.38E3	2.38E3
C 14	3.23E6	6.89E5	6.89E5	6.89E5	6.89E5	6.89E5	6.89E5
Cr 51	--	--	8.35E4	5.45E4	1.19E4	1.06E5	2.43E6
Mn 54	--	2.51E7	5.68E6	--	5.56E6	--	9.21E6
Fe 55	8.43E7	5.44E7	1.45E7	--	--	2.66E7	6.91E6
Fe 59	1.22E8	2.13E8	8.38E7	--	--	6.29E7	1.02E8
Co 58	--	1.39E7	3.46E7	--	--	--	3.46E7
Co 60	--	5.90E7	1.39E8	--	--	--	1.40E8
Zn 65	3.53E9	1.21E10	5.58E9	--	5.87E9	--	1.02E10
Sr 89	6.93E9	--	1.99E8	--	--	--	1.42E8
Sr 90	8.19E10	--	2.09E10	--	--	--	1.02E9
Zr 95	3.85E3	9.39E2	6.66E2	--	1.01E3	--	4.68E5
Nb 95	4.21E5	1.64E5	1.17E5	--	1.54E5	--	3.03E8
Mo 99	--	1.04E8	2.03E7	--	1.55E8	--	3.43E7
I 131	6.81E8	8.02E8	3.53E8	2.64E11	9.37E8	--	2.86E7
I 133	8.52E6	1.24E7	3.63E6	2.26E9	1.46E7	--	2.10E6
Cs 134	2.41E10	4.49E10	4.54E9	--	1.16E10	4.74E9	1.22E8
Cs 137	3.47E10	4.06E10	2.88E9	--	1.09E10	4.41E9	1.27E8
Ba 140	1.21E8	1.21E5	6.22E6	--	2.87E4	7.42E4	2.97E7
La 140	2.03E1	7.99	2.06	--	--	--	9.39E4
Ce 141	2.28E4	1.39E4	1.64E3	--	4.28E3	--	7.18E6
Ce 144	1.49E6	6.10E5	8.34E4	--	2.46E5	--	8.54E7
Nd 147	4.43E2	4.55E2	2.79E1	--	1.76E2	--	2.89E5

mrem/yr per $\mu Ci/m^3$.



TABLE 3-10
DOSE AND DOSE RATE
R₁ VALUES - COW MILK - CHILD
 $\frac{m^2 \cdot mrem/yr}{\mu Ci/sec}$

<u>NUCLIDE</u>	<u>BONE</u>	<u>LIVER</u>	<u>T. BODY</u>	<u>THYROID</u>	<u>KIDNEY</u>	<u>LUNG</u>	<u>GI-LLI</u>
H 3	--	1.57E3	1.57E3	1.57E3	1.57E3	1.57E3	1.57E3
C 14	1.65E6	3.29E5	3.29E5	3.29E5	3.29E5	3.29E5	3.29E5
Cr 51	--	--	5.27E4	2.93E4	7.99E3	5.34E4	2.80E6
Mn 54	--	1.35E7	3.59E6	--	3.78E6	--	1.13E7
Fe 55	6.97E7	3.07E7	1.15E7	--	--	2.09E7	6.85E6
Fe 59	6.52E7	1.06E8	5.26E7	--	--	3.06E7	1.10E8
Co 58	--	6.94E6	2.13E7	--	--	--	4.05E7
Co 60	--	2.89E7	8.52E7	--	--	--	1.60E8
Zn 65	2.63E9	7.00E9	4.35E9	--	4.41E9	--	1.23E9
Sr 89	3.64E9	--	1.04E8	--	--	--	1.41E8
Sr 90	7.53E10	--	1.91E10	--	--	--	1.01E9
Zr 95	2.17E3	4.77E2	4.25E2	--	6.83E2	--	4.98E5
Nb 95	1.86E5	1.03E4	5.69E4	--	1.00E5	--	4.42E8
Mo 99	--	4.07E7	1.01E7	--	8.69E7	--	3.37E7
I 131	3.26E8	3.28E8	1.86E8	1.08E11	5.39E8	--	2.92E7
I 133	4.04E6	4.99E6	1.89E6	9.27E8	8.32E6	--	2.01E6
Cs 134	1.50E10	2.45E10	5.18E9	--	7.61E9	2.73E9	1.32E8
Cs 137	2.17E10	2.08E10	3.07E9	--	6.78E9	2.44E9	1.30E8
Ba 140	5.87E7	5.14E4	3.43E6	--	1.67E4	3.07E4	2.97E7
La 140	9.70	3.39	1.14	--	--	--	9.45E4
Ce 141	1.15E4	5.73E3	8.51E2	--	2.51E3	--	7.15E6
Ce 144	1.04E6	3.26E5	5.55E4	--	1.80E5	--	8.49E7
Nd 147	2.24E2	1.81E2	1.40E1	--	9.94E1	--	2.87E5

mrem/yr per $\mu Ci/m^3$.



TABLE 3-11
DOSE AND DOSE RATE
R₁ VALUES - COW MILK - TEEN
 $\frac{m^2 \cdot mrem/yr}{\mu Ci/sec}$

NUCLIDE	BONE	LIVER	T. BODY	THYROID	KIDNEY	LUNG	GI-LLI
H 3 [*]	--	9.94E2	9.94E2	9.94E2	9.94E2	9.94E2	9.94E2
C 14 [*]	6.70E5	1.34E5	1.34E5	1.34E5	1.34E5	1.35E5	1.34E5
Cr 51	--	--	2.58E4	1.44E4	5.66E3	3.69E4	4.34E6
Mn 54	--	9.01E6	1.79E6	--	2.69E6	--	1.85E7
Fe 55	2.78E7	1.97E7	4.59E6	--	--	1.25E7	8.52E6
Fe 59	2.81E7	6.57E7	2.54E7	--	--	2.07E7	1.55E8
Co 58	--	4.55E6	1.05E7	--	--	--	6.27E7
Co 60	--	1.86E7	4.19E7	--	--	--	2.42E8
Zn 65	1.34E9	4.65E9	2.17E9	--	2.97E9	--	1.97E9
Sr 89	1.47E9	--	4.21E7	--	--	--	1.75E8
Sr 90	4.45E10	--	1.10E10	--	--	--	1.25E9
Zr 95	9.34E2	2.95E2	2.03E2	--	4.33E2	--	6.80E5
Nb 95	1.86E5	1.03E5	5.69E4	--	1.00E5	--	4.42E8
Mo 99	--	2.24E7	4.27E6	--	5.12E7	--	4.01E7
I 131	1.34E8	1.88E8	1.01E8	5.49E10	3.24E8	--	3.72E7
I 133	1.66E6	2.82E6	8.59E5	3.93E8	4.94E6	--	2.13E6
Cs 134	6.49E9	1.53E10	7.08E9	--	4.85E9	1.85E9	1.90E8
Cs 137	9.02E9	1.20E10	4.18E9	--	4.08E9	1.59E9	1.71E8
Ba 140	2.43E7	2.98E4	1.57E6	--	1.01E4	2.00E4	3.75E7
La 140	4.05	1.99	5.30E-1	--	--	--	1.14E5
Ce 141	4.67E3	3.12E3	3.58E2	--	1.47E3	--	8.91E6
Ce 144	4.22E5	1.74E5	2.27E4	--	1.04E5	--	1.06E8
Nd 147	9.12E1	9.91E1	5.94E0	--	5.82E1	--	3.58E5

*mrem/yr per $\mu Ci/m^3$.

22
4
118



TABLE 3-12
DOSE AND DOSE RATE
R₁ VALUES - COW MILK - ADULT
 $\frac{m^2 \cdot mrem/yr}{\mu Ci/sec}$

NUCLIDE	BONE	LIVER	T. BODY	THYROID	KIDNEY	LUNG	GI-LLI
H 3	--	7.63E2	7.63E2	7.63E2	7.63E2	7.63E2	7.63E2
C 14	3.63E5	7.26E4	7.26E4	7.26E4	7.26E4	7.26E4	7.26E4
Cr 51	--	--	1.48E4	8.85E3	3.26E3	1.96E4	3.72E6
Mn 54	--	5.41E6	1.03E6	--	1.61E6	--	1.66E7
Fe 55	1.57E7	1.08E7	2.52E6	--	--	6.04E6	6.21E6
Fe 59	1.61E7	3.79E7	1.45E7	--	--	1.06E7	1.26E8
Co 58	--	2.70E6	6.05E6	--	--	--	5.47E7
Co 60	--	1.10E7	2.42E7	--	--	--	2.06E8
Zn 65	8.71E8	2.77E9	1.25E9	--	1.85E9	--	1.75E9
Sr 89	7.99E8	--	2.29E7	--	--	--	1.28E8
Sr 90	3.15E10	--	7.74E9	--	--	--	9.11E8
Zr 95	5.34E2	1.71E2	1.16E2	--	2.69E2	--	5.43E5
Nb 95	1.09E5	6.07E4	3.27E4	--	6.00E4	--	3.69E8
Mo 99	--	1.24E7	2.36E6	--	2.81E7	--	2.87E7
I 131	7.41E7	1.06E8	6.08E7	3.47E10	1.82E8	--	2.80E7
I 133	9.09E5	1.58E6	4.82E5	2.32E8	2.76E6	--	1.42E6
Cs 134	3.74E9	8.89E9	7.27E9	--	2.88E9	9.55E8	1.56E8
Cs 137	4.97E9	6.80E9	4.46E9	--	2.31E9	7.68E8	1.32E8
Ba 140	1.35E7	1.69E4	8.83E5	--	5.75E3	9.69E3	2.77E7
La 140	2.26	1.14	3.01E-1	--	--	--	8.35E4
Ce 141	2.54E3	1.72E3	1.95E2	--	7.99E2	--	6.58E6
Ce 144	2.29E5	9.58E4	1.23E4	--	5.68E4	--	7.74E7
Nd 147	4.74E1	5.48E1	3.28E0	--	3.20E1	--	2.63E5

$m^2 \cdot mrem/yr$ per $\mu Ci/m^3$.

10
11
12
13



TABLE 3-13
DOSE AND DOSE RATE
R₁ VALUES - GOAT MILK - INFANT
 $\frac{m^2 \cdot mrem/yr}{\mu Ci/sec}$

<u>NUCLIDE</u>	<u>BONE</u>	<u>LIVER</u>	<u>T. BODY</u>	<u>THYROID</u>	<u>KIDNEY</u>	<u>LUNG</u>	<u>GI-LLI</u>
H 3 ^m	--	6.33E3	6.33E3	6.33E3	6.33E3	6.33E3	6.33E3
C 14 ^m	3.23E6	6.89E5	6.89E5	6.89E5	6.89E5	6.89E5	6.89E5
Cr 51	--	--	1.00E4	6.56E3	1.43E3	1.28E4	2.93E5
Mn 54	--	3.01E6	6.82E5	--	6.67E5	--	1.11E6
Fe 55	1.10E6	7.08E5	1.89E5	--	--	3.46E5	8.98E4
Fe 59	1.59E6	2.78E6	1.09E6	--	--	8.21E5	1.33E6
Co 58	--	1.67E6	4.16E6	--	--	--	4.16E6
Co 60	--	7.08E6	1.67E7	--	--	--	1.68E7
Zn 65	4.24E8	1.45E9	6.70E8	--	7.04E8	--	1.23E9
Sr 89	1.48E10	--	4.24E8	--	--	--	3.04E8
Sr 90	1.72E11	--	4.38E10	--	--	--	2.15E9
Zr 95	4.66E2	1.13E2	8.04E1	--	1.22E2	--	5.65E4
Nb 95	9.42E4	3.88E4	2.24E4	--	2.78E4	--	3.27E7
Mo 99	--	1.27E7	2.47E6	--	1.89E7	--	4.17E6
I 131	8.17E8	9.63E8	4.23E8	3.16E11	1.12E9	--	3.44E7
I 133	1.02E7	1.49E7	4.36E6	2.71E9	1.75E7	--	2.52E6
Cs 134	7.23E10	1.35E11	1.36E10	--	3.47E10	1.42E10	3.66E8
Cs 137	1.04E11	1.22E11	8.63E9	--	3.27E10	1.32E10	3.81E8
Ba 140	1.45E7	1.45E4	7.48E5	--	3.44E3	8.91E3	3.56E6
La 140	2.430	9.59E-1	2.47E-1	--	--	--	1.13E4
Ce 141	2.74E3	1.67E3	1.96E2	--	5.14E2	--	8.62E5
Ce 144	1.79E5	7.32E4	1.00E4	--	2.96E4	--	1.03E7
Nd 147	5.32E1	5.47E1	3.35E0	--	2.11E1	--	3.46E4

^mmrem/yr per $\mu Ci/m^3$.

2
3
4
5
6



TABLE 3-14
DOSE AND DOSE RATE
R₁ VALUES - GOAT MILK - CHILD
 $\frac{m^2 \cdot mrem/yr}{\mu Ci/sec}$

<u>NUCLIDE</u>	<u>BONE</u>	<u>LIVER</u>	<u>T. BODY</u>	<u>THYROID</u>	<u>KIDNEY</u>	<u>LUNG</u>	<u>GI-LLI</u>
H 3*	--	4.17E3	4.17E3	4.17E3	4.17E3	4.17E3	4.17E3
C 14*	1.65E6	3.29E5	3.29E5	3.29E5	3.29E5	3.29E5	3.29E5
Cr 51	--	--	6.34E3	3.52E3	9.62E2	6.43E3	3.36E5
Mn 54	--	1.62E6	4.31E5	--	4.54E5	--	1.36E6
Fe 55	9.06E5	4.81E5	1.49E5	--	--	2.72E5	8.91E4
Fe 59	8.52E5	1.38E6	6.86E5	--	--	3.99E5	1.43E6
Co 58	--	8.35E5	2.56E6	--	--	--	4.87E6
Co 60	--	3.47E6	1.02E7	--	--	--	1.92E7
Zn 65	3.15E8	8.40E8	5.23E8	--	5.29E8	--	1.48E8
Sr 89	7.77E9	--	2.22E8	--	--	--	3.01E8
Sr 90	1.58E11	--	4.01E10	--	--	--	2.13E9
Zr 95	2.62E2	5.76E1	5.13E1	--	8.25E1	--	6.01E4
Nb 95	5.05E4	1.96E4	1.40E4	--	1.85E4	--	3.63E7
Mo 99	--	4.95E6	1.22E6	--	1.06E7	--	4.09E6
I 131	3.91E8	3.94E8	2.24E8	1.30E11	6.46E8	--	3.50E7
I 133	4.84E6	5.99E6	2.27E6	1.11E9	9.98E6	--	2.41E6
Cs 134	4.49E10	7.37E10	1.55E10	--	2.28E10	8.19E9	3.97E8
Cs 137	6.52E10	6.24E10	9.21E9	--	2.03E10	7.32E9	3.91E8
Ba 140	7.05E6	6.18E3	4.12E5	--	2.01E3	3.68E3	3.57E6
La 140	1.16	4.07E-1	1.37E-1	--	--	--	1.13E4
Ce 141	1.38E3	6.88E2	1.02E2	--	3.02E2	--	8.59E5
Ce 144	1.25E5	3.91E4	6.66E3	--	2.16E4	--	1.02E7
Nd 147	2.68E1	2.17E1	1.68E0	--	1.19E1	--	3.44E4

*mrem/yr per $\mu Ci/m^3$.

11
12
13
14



TABLE 3-15
DOSE AND DOSE RATE
R₁ VALUES - GOAT MILK - TEEN
 $\frac{m^2 \cdot mrem/yr}{\mu Ci/sec}$

NUCLIDE	BONE	LIVER	T. BODY	THYROID	KIDNEY	LUNG	GI-LLI
H 3	--	2.64E3	2.64E3	2.64E3	2.64E3	2.64E3	2.64E3
C 14	6.70E5	1.34E5	1.34E5	1.34E5	1.34E5	1.35E5	1.34E5
Cr 51	--	--	3.11E3	1.73E3	6.82E2	4.44E3	5.23E5
Mn 54	--	1.08E6	2.15E5	--	3.23E5	--	2.22E6
Fe 55	3.61E5	2.56E5	5.97E4	--	--	1.62E5	1.11E5
Fe 59	3.67E5	8.57E5	3.31E5	--	--	2.70E5	2.03E6
Co 58	--	5.46E5	1.26E6	--	--	--	7.53E6
Co 60	--	2.23E6	5.03E6	--	--	--	2.91E7
Zn 65	1.61E8	5.58E8	2.60E8	--	3.57E8	--	2.36E8
Sr 89	3.14E9	--	8.99E7	--	--	--	3.74E8
Sr 90	9.36E10	--	2.31E10	--	--	--	2.63E9
Zr 95	1.13E2	3.56E1	2.45E1	--	5.23E1	--	8.22E4
Nb 95	2.23E4	1.24E4	6.82E3	--	1.20E4	--	5.30E7
Mo 99	--	2.72E6	5.19E5	--	6.23E6	--	4.87E6
I 131	1.61E8	2.26E8	1.21E8	6.59E10	3.89E8	--	4.47E7
I 133	1.99E6	3.38E6	1.03E6	4.72E8	5.93E6	--	2.56E6
Cs 134	1.95E10	4.58E10	2.13E10	--	1.46E10	5.56E9	5.70E8
Cs 137	2.71E10	3.60E10	1.25E10	--	1.23E10	4.76E9	5.12E8
Ba 140	2.92E6	3.58E3	1.88E5	--	1.21E3	2.41E3	4.50E6
La 140	4.86E-1	2.39E-1	6.36E-2	--	--	--	1.37E4
Ce 141	5.60E2	3.74E2	4.30E1	--	1.76E2	--	1.07E6
Ce 144	5.06E4	2.09E4	2.72E3	--	1.25E4	--	1.27E7
Nd 147	1.09E1	1.19E1	7.13E-1	--	6.99E0	--	4.29E4

^mmrem/yr per $\mu Ci/m^3$.

10
11
12
13



TABLE 3-16
DOSE AND DOSE RATE
R₁ VALUES - GOAT MILK - ADULT
 $\frac{m^2 \cdot mrem/yr}{\mu Ci/sec}$

NUCLIDE	BONE	LIVER	T. BODY	THYROID	KIDNEY	LUNG	GI-LLI
H 3 [*]	--	2.03E3	2.03E3	2.03E3	2.03E3	2.03E3	2.03E3
C 14 [*]	3.63E5	7.26E4	7.26E4	7.26E4	7.26E4	7.26E4	7.26E4
Cr 51	--	--	1.78E3	1.06E3	3.92E2	2.36E3	4.48E5
Mn 54	--	6.50E5	1.24E5	--	1.93E5	--	1.99E6
Fe 55	2.04E5	1.41E5	3.28E4	--	--	7.85E4	8.07E4
Fe 59	2.10E5	4.95E5	1.90E5	--	--	1.38E5	1.65E6
Co 58	--	3.25E5	7.27E5	--	--	--	6.58E6
Co 60	--	1.32E6	2.91E6	--	--	--	2.48E7
Zn 65	1.05E8	3.33E8	1.51E8	--	2.23E8	--	2.10E8
Sr 89	1.70E9	--	4.89E7	--	--	--	2.73E8
Sr 90	6.62E10	--	1.63E10	--	--	--	1.91E9
Zr 95	6.45E1	2.07E1	1.40E1	--	3.25E1	--	6.56E4
Nb 95	1.31E4	7.29E3	3.92E3	--	7.21E3	--	4.42E7
Mo 99	--	1.51E6	2.87E5	--	3.41E6	--	3.49E6
I 131	8.89E7	1.27E8	7.29E7	4.17E10	2.18E8	--	3.36E7
I 133	1.09E6	1.90E6	5.79E5	2.79E8	3.31E6	--	1.71E6
Cs 134	1.12E10	2.67E10	2.18E10	--	8.63E9	2.86E9	4.67E8
Cs 137	1.49E10	2.04E10	1.34E10	--	6.93E9	2.30E9	3.95E8
Ba 140	1.62E6	2.03E3	1.06E5	--	6.91E2	1.16E3	3.33E6
La 140	2.71E-1	1.36E-1	3.61E-2	--	--	--	1.00E4
Ce 141	3.06E2	2.07E2	2.34E1	--	9.60E1	--	7.90E5
Ce 144	2.75E4	1.15E4	1.48E3	--	6.82E3	--	9.30E6
Nd 147	5.69E0	6.57E0	3.93E-1	--	3.84E0	--	3.15E4

*mrem/yr per $\mu Ci/m^3$.

1
2
3
4
5
6
7
8
9
10
11
12
13
14
15
16
17
18
19
20
21
22
23
24
25
26
27
28
29
30
31
32
33
34
35
36
37
38
39
40
41
42
43
44
45
46
47
48
49
50
51
52
53
54
55
56
57
58
59
60
61
62
63
64
65
66
67
68
69
70
71
72
73
74
75
76
77
78
79
80
81
82
83
84
85
86
87
88
89
90
91
92
93
94
95
96
97
98
99
100



TABLE 3-17
DOSE AND DOSE RATE
R_i VALUES - COW MEAT - CHILD
 $\frac{m^2 \cdot mrem/yr}{\mu Ci/sec}$

<u>NUCLIDE</u>	<u>BONE</u>	<u>LIVER</u>	<u>T. BODY</u>	<u>THYROID</u>	<u>KIDNEY</u>	<u>LUNG</u>	<u>GI-LLI</u>
H 3 ^m	--	2.34E2	2.34E2	2.34E2	2.34E2	2.34E2	2.34E2
C 14 ^m	5.29E5	1.06E5	1.06E5	1.06E5	1.06E5	1.06E5	1.06E5
Cr 51	--	--	4.55E3	2.52E3	6.90E2	4.61E3	2.41E5
Mn 54	--	5.15E6	1.37E6	--	1.44E6	--	4.32E6
Fe 55	2.89E8	1.53E8	4.74E7	--	--	8.66E7	2.84E7
Fe 59	2.04E8	3.30E8	1.65E8	--	--	9.58E7	3.44E8
Co 58	--	9.41E6	2.88E7	--	--	--	5.49E7
Co 60	--	4.64E7	1.37E8	--	--	--	2.57E8
Zn 65	2.38E8	6.35E8	3.95E8	--	4.00E8	--	1.12E8
Sr 89	2.65E8	--	7.57E6	--	--	--	1.03E7
Sr 90	7.01E9	--	1.78E9	--	--	--	9.44E7
Zr 95	1.51E6	3.32E5	2.95E5	--	4.75E5	--	3.46E8
Nb 95	4.10E6	1.59E6	1.14E6	--	1.50E6	--	2.95E9
Mo 99	--	5.42E4	1.34E4	--	1.16E5	--	4.48E4
I 131	4.15E6	4.18E6	2.37E6	1.38E9	6.86E6	--	3.72E5
I 133	9.38E-2	1.16E-1	4.39E-2	2.15E1	1.93E-1	--	4.67E-2
Cs 134	6.09E8	1.00E9	2.11E8	--	3.10E8	1.11E8	5.39E6
Cs 137	8.99E8	8.60E8	1.27E8	--	2.80E8	1.01E8	5.39E6
Ba 140	2.20E7	1.93E4	1.28E6	--	6.27E3	1.15E4	1.11E7
La 140	2.80E-2	9.78E-3	3.30E-3	--	--	--	2.73E2
Ce 141	1.17E4	5.82E3	8.64E2	--	2.55E3	--	7.26E6
Ce 144	1.48E6	4.65E5	7.91E4	--	2.57E5	--	1.21E8
Nd 147	5.93E3	4.80E3	3.72E2	--	2.64E3	--	7.61E6

^mmrem/yr per $\mu Ci/m^3$.



TABLE 3-18
DOSE AND DOSE RATE
R₁ VALUES - COW MEAT - TEEN
 $\frac{m^2 \cdot mrem/yr}{\mu Ci/sec}$

NUCLIDE	BONE	LIVER	T. BODY	THYROID	KIDNEY	LUNG	GI-LLI
H 3 ^m	--	1.94E2	1.94E2	1.94E2	1.94E2	1.94E2	1.94E2
C 14 ^m	2.81E5	5.62E4	5.62E4	5.62E4	5.62E4	5.62E4	5.62E4
Cr 51	--	--	2.93E3	1.62E3	6.39E2	4.16E3	4.90E5
Mn 54	--	4.50E6	8.93E5	--	1.34E6	--	9.24E6
Fe 55	1.50E8	1.07E8	2.49E7	--	--	6.77E7	4.62E7
Fe 59	1.15E8	2.69E8	1.04E8	--	--	8.47E7	6.36E8
Co 58	--	8.05E6	1.86E7	--	--	--	1.11E8
Co 60	--	3.90E7	8.80E7	--	--	--	5.09E8
Zn 65	1.59E8	5.52E8	2.57E8	--	3.53E8	--	2.34E8
Sr 89	1.40E8	--	4.01E6	--	--	--	1.67E7
Sr 90	5.42E9	--	1.34E9	--	--	--	1.52E8
Zr 95	8.50E5	2.68E5	1.84E5	--	3.94E5	--	6.19E8
Nb 95	2.37E6	1.32E6	7.24E5	--	1.28E6	--	5.63E9
Mo 99	--	3.90E4	7.43E3	--	8.92E4	--	6.98E4
I 131	2.24E6	3.13E6	1.68E6	9.15E8	5.40E6	--	6.20E5
I 133	5.05E-2	8.57E-2	2.61E-2	1.20E1	1.50E-1	--	6.48E-2
Cs 134	3.46E8	8.13E8	3.77E8	--	2.58E8	9.87E7	1.01E7
Cs 137	4.88E8	6.49E8	2.26E8	--	2.21E8	8.58E7	9.24E6
Ba 140	1.19E7	1.46E4	7.68E5	--	4.95E3	9.81E3	1.84E7
La 140	1.53E-2	7.51E-3	2.00E-3	--	--	--	4.31E2
Ce 141	6.19E3	4.14E3	4.75E2	--	1.95E3	--	1.18E7
Ce 144	7.87E5	3.26E5	4.23E4	--	1.94E5	--	1.98E8
Nd 147	3.16E3	3.44E3	2.06E2	--	2.02E3	--	1.24E7

^mmrem/yr per $\mu Ci/m^3$.



TABLE 3-19
DOSE AND DOSE RATE
R₁ VALUES - COW MEAT - ADULT
 $\frac{m^2 \cdot mrem/yr}{\mu Ci/sec}$

<u>NUCLIDE</u>	<u>BONE</u>	<u>LIVER</u>	<u>T. BODY</u>	<u>THYROID</u>	<u>KIDNEY</u>	<u>LUNG</u>	<u>GI-LLI</u>
H 3 ^m	--	3.25E2	3.25E2	3.25E2	3.25E2	3.25E2	3.25E2
C 14 ^m	3.33E5	6.66E4	6.66E4	6.66E4	6.66E4	6.66E4	6.66E4
Cr 51	--	--	3.65E3	2.18E3	8.03E2	4.84E3	9.17E5
Mn 54	--	5.90E6	1.13E6	--	1.76E6	--	1.81E7
Fe 55	1.85E8	1.28E8	2.98E7	--	--	7.14E7	7.34E7
Fe 59	1.44E8	3.39E8	1.30E8	--	--	9.46E7	1.13E9
Co 58	--	1.04E7	2.34E7	--	--	--	2.12E8
Co 60	--	5.03E7	1.11E8	--	--	--	9.45E8
Zn 65	2.26E8	7.19E8	3.25E8	--	4.81E8	--	4.53E8
Sr 89	1.66E8	--	4.76E6	--	--	--	2.66E7
Sr 90	8.38E9	--	2.06E9	--	--	--	2.42E8
Zr 95	1.06E6	3.40E5	2.30E5	--	5.34E5	--	1.08E9
Nb 95	3.04E6	1.69E6	9.08E5	--	1.67E6	--	1.03E10
Mo 99	--	4.71E4	8.97E3	--	1.07E5	--	1.09E5
I 131	2.69E6	3.85E6	2.21E6	1.26E9	6.61E6	--	1.02E6
I 133	6.04E-2	1.05E-1	3.20E-2	1.54E1	1.83E-1	--	9.44E-2
Cs 134	4.35E8	1.03E9	8.45E8	--	3.35E8	1.11E8	1.81E7
Cs 137	5.88E8	8.04E8	5.26E8	--	2.73E8	9.07E7	1.56E7
Ba 140	1.44E7	1.81E4	9.44E5	--	6.15E3	1.04E4	2.97E7
La 140	1.86E-2	9.37E-3	2.48E-3	--	--	--	6.88E2
Ce 141	7.38E3	4.99E3	5.66E2	--	2.32E3	--	1.91E7
Ce 144	9.33E5	3.90E5	5.01E4	--	2.31E5	--	3.16E8
Nd 147	3.59E3	4.15E3	2.48E2	--	2.42E3	--	1.99E7

^mmrem/yr per $\mu Ci/m^3$.

1
2
3
4



TABLE 3-20
DOSE AND DOSE RATE
R₁ VALUES - VEGETATION - CHILD
 $\frac{m^2 \cdot mrem/yr}{\mu Ci/sec}$

NUCLIDE	BONE	LIVER	T. BODY	THYROID	KIDNEY	LUNG	GI-LLI
H 3	--	4.01E3	4.01E3	4.01E3	4.01E3	4.01E3	4.01E3
C 14	3.50E6	7.01E5	7.01E5	7.01E5	7.01E5	7.01E5	7.01E5
Cr 51	--	--	1.17E5	6.49E4	1.77E4	1.18E5	6.20E6
Mn 54	--	6.65E8	1.77E8	--	1.86E8	--	5.58E8
Fe 55	7.63E8	4.05E8	1.25E8	--	--	2.29E8	7.50E7
Fe 59	3.97E8	6.42E8	3.20E8	--	--	1.86E8	6.69E8
Co 58	--	6.45E7	1.97E8	--	--	--	3.76E8
Co 60	--	3.78E8	1.12E9	--	--	--	2.10E9
Zn 65	8.12E8	2.16E9	1.35E9	--	1.36E9	--	3.80E8
Sr 89	3.59E10	--	1.03E9	--	--	--	1.39E9
Sr 90	1.24E12	--	3.15E11	--	--	--	1.67E10
Zr 95	3.86E6	8.50E5	7.56E5	--	1.22E6	--	8.86E8
Nb 95	1.02E6	3.99E5	2.85E5	--	3.75E5	--	7.37E8
Mo 99	--	7.70E6	1.91E6	--	1.65E7	--	6.37E6
I 131	7.16E7	7.20E7	4.09E7	2.38E10	1.18E8	--	6.41E6
I 133	1.69E6	2.09E6	7.92E5	3.89E8	3.49E6	--	8.44E5
Cs 134	1.60E10	2.63E10	5.55E9	--	8.15E9	2.93E9	1.42E8
Cs 137	2.39E10	2.29E10	3.38E9	--	7.46E9	2.68E9	1.43E8
Ba 140	2.77E8	2.43E5	1.62E7	--	7.90E4	1.45E5	1.40E8
La 140	3.25E3	1.13E3	3.83E2	--	--	--	3.16E7
Ce 141	6.56E5	3.27E5	4.85E4	--	1.43E5	--	4.08E8
Ce 144	1.27E8	3.98E7	6.78E6	--	2.21E7	--	1.04E10
Nd 147	7.23E4	5.86E4	4.54E3	--	3.22E4	--	9.28E7

*mrem/yr per $\mu Ci/m^3$.



TABLE 3-21
DOSE AND DOSE RATE
R₁ VALUES - VEGETATION - TEEN
 $\frac{m^2 \cdot mrem/yr}{\mu Ci/sec}$

NUCLIDE	BONE	LIVER	T. BODY	THYROID	KIDNEY	LUNG	GI-LLI
H 3 [*]	--	2.59E3	2.59E3	2.59E3	2.59E3	2.59E3	2.59E3
C 14 [*]	1.45E6	2.91E5	2.91E5	2.91E5	2.91E5	2.91E5	2.91E5
Cr 51	--	--	6.16E4	3.42E4	1.35E4	8.79E4	1.03E7
Mn 54	--	4.54E8	9.01E7	--	1.36E8	--	9.32E8
Fe 55	3.10E8	2.20E8	5.13E7	--	--	1.40E8	9.53E7
Fe 59	1.79E8	4.18E8	1.61E8	--	--	1.32E8	9.89E8
Co 58	--	4.37E7	1.01E8	--	--	--	6.02E8
Co 60	--	2.49E8	5.60E8	--	--	--	3.24E9
Zn 65	4.24E8	1.47E9	6.86E8	--	9.41E8	--	6.23E8
Sr 89	1.51E10	--	4.33E8	--	--	--	1.80E9
Sr 90	7.51E11	--	1.85E11	--	--	--	2.11E10
Zr 95	1.72E6	5.44E5	3.74E5	--	7.99E5	--	1.26E9
Nb 95	4.80E5	2.66E5	1.46E5	--	2.58E5	--	1.14E9
Mo 99	--	5.64E6	1.08E6	--	1.29E7	--	1.01E7
I 131	3.85E7	5.39E7	2.89E7	1.57E10	9.28E7	--	1.07E7
I 133	9.29E5	1.58E6	4.80E5	2.20E8	2.76E6	--	1.19E6
Cs 134	7.10E9	1.67E10	7.75E9	--	5.31E9	2.03E9	2.08E8
Cs 137	1.01E10	1.35E10	4.69E9	--	4.59E9	1.78E9	1.92E8
Ba 140	1.38E8	1.69E5	8.91E6	--	5.74E4	1.14E5	2.13E8
La 140	1.81E3	8.88E2	2.36E2	--	--	--	5.10E7
Ce 141	2.83E5	1.89E5	2.17E4	--	8.89E4	--	5.40E8
Ce 144	5.27E7	2.18E7	2.83E6	--	1.30E7	--	1.33E10
Nd 147	3.66E4	3.98E4	2.38E3	--	2.34E4	--	1.44E8

*mrem/yr per $\mu Ci/m^3$

1
2
3
4
5
6
7
8
9
10
11
12
13
14
15
16
17
18
19
20
21
22
23
24
25
26
27
28
29
30
31
32
33
34
35
36
37
38
39
40
41
42
43
44
45
46
47
48
49
50
51
52
53
54
55
56
57
58
59
60
61
62
63
64
65
66
67
68
69
70
71
72
73
74
75
76
77
78
79
80
81
82
83
84
85
86
87
88
89
90
91
92
93
94
95
96
97
98
99
100



TABLE 3-22
DOSE AND DOSE RATE
R_i VALUES - VEGETATION - ADULT
 $\frac{m^2 \cdot mrem/yr}{\mu Ci/sec}$

<u>NUCLIDE</u>	<u>BONE</u>	<u>LIVER</u>	<u>T. BODY</u>	<u>THYROID</u>	<u>KIDNEY</u>	<u>LUNG</u>	<u>GI-LLI</u>
H 3 [*]	--	2.26E3	2.26E3	2.26E3	2.26E3	2.26E3	2.26E3
C 14 [*]	8.97E5	1.79E5	1.79E5	1.79E5	1.79E5	1.79E5	1.79E5
Cr 51	--	--	4.64E4	2.77E4	1.02E4	6.15E4	1.17E7
Mn 54	--	3.13E8	5.97E7	--	9.31E7	--	9.58E8
Fe 55	2.00E8	1.38E8	3.22E7	--	--	7.69E7	7.91E7
Fe 59	1.26E8	2.96E8	1.13E8	--	--	8.27E7	1.02E9
Co 58	--	3.08E7	6.90E7	--	--	--	6.24E8
Co 60	--	1.67E8	3.69E8	--	--	--	3.14E9
Zn 65	3.17E8	1.01E9	4.56E8	--	6.75E8	--	6.36E8
Sr 89	9.96E9	--	2.86E8	--	--	--	1.60E9
Sr 90	6.05E11	--	1.48E11	--	--	--	1.75E10
Zr 95	1.18E6	3.77E5	2.55E5	--	5.92E5	--	1.20E9
Nb 95	3.55E5	1.98E5	1.06E5	--	1.95E5	--	1.20E9
Mo 99	--	6.14E6	1.17E6	--	1.39E7	--	1.42E7
I 131	4.04E7	5.78E7	3.31E7	1.90E10	9.91E7	--	1.53E7
I 133	1.00E6	1.74E6	5.30E5	2.56E8	3.03E6	--	1.56E6
Cs 134	4.67E9	1.11E10	9.08E9	--	3.59E9	1.19E9	1.94E8
Cs 137	6.36E9	8.70E9	5.70E9	--	2.95E9	9.81E8	1.68E8
Ba 140	1.29E8	1.61E5	8.42E6	--	5.49E4	9.25E4	2.65E8
La 140	1.98E3	9.97E2	2.63E2	--	--	--	7.32E7
Ce 141	1.97E5	1.33E5	1.51E4	--	6.19E4	--	5.09E8
Ce 144	3.29E7	1.38E7	1.77E6	--	8.16E6	--	1.11E10
Nd 147	3.36E4	3.88E4	2.32E3	--	2.27E4	--	1.86E8

^{*}mrem/yr per $\mu Ci/m^3$



TABLE 3-23
 PARAMETERS FOR THE EVALUATION OF DOSES TO REAL MEMBERS
 OF THE PUBLIC FROM GASEOUS AND LIQUID EFFLUENTS

<u>Pathway</u>	<u>Parameters</u>	<u>Value</u>	<u>Reference</u>
Fish	U (kg/yr) - adult	21	Reg. Guide 1.109 Table E-5
Fish	D_{airj} (mrem/pCi)	Each Radionuclide	Reg. Guide 1.109 Table E-11
Shoreline	U (hr/yr) - adult - teen	67 67	Reg. Guide 1.09 Assumed to be same as Adult
Shoreline	D_{airj} (mrem/hr per pCi/m ²)	Each Radionuclide	Reg. Guide 1.109 Table E-6
Inhalation	DFA_{ij}	Each Radionuclide	Reg. Guide 1.109 Table E-7

1
2
3
4



**NINE MILE POINT NUCLEAR STATION
RADIOLOGICAL ENVIRONMENTAL MONITORING PROGRAM
SAMPLING LOCATIONS**

TABLE 5.1 .

Type of Sample	★ Map Location	Collection Site (Env. Program No.)	Location
Radioiodine and Particulates (air)	1	Nine Mile Point Road North (R-1)	1.8 mi @ 88° E
Radioiodine and Particulates (air)	2	Co. Rt. 29 & Lake Road (R-2)	1.1 mi @ 104° ESE
Radioiodine and Particulates (air)	3	Co. Rt. 29 (R-3)	1.5 mi @ 132° SE
Radioiodine and Particulates (air)	4	Village of Lycoming, NY (R-4)	1.8 mi @ 143° SE
Radioiodine and Particulates (air)	5	Montario Point Road (R-5)	16.4 mi @ 42° NE
Direct Radiation (TLD)	6	North Shoreline Area (75)	0.1 mi @ 5° N
Direct Radiation (TLD)	7	North Shoreline Area (76)	0.1 mi @ 25° NNE
Direct Radiation (TLD)	8	North Shoreline Area (77)	0.2 mi @ 45° NE
Direct Radiation (TLD)	9	North Shoreline Area (23)	0.8 mi @ 70° ENE
Direct Radiation (TLD)	10	JAF East Boundary (78)	1.0 mi @ 90° E
Direct Radiation (TLD)	11	Rt. 29 (79)	1.1 mi @ 115° ESE
Direct Radiation (TLD)	12	Rt. 29 (80)	1.4 mi @ 133° SE
Direct Radiation (TLD)	13	Miner Road (81)	1.6 mi @ 159° SSE
Direct Radiation (TLD)	14	Miner Road (82)	1.6 mi @ 181° S
Direct Radiation (TLD)	15	Lakeview Road (83)	1.2 mi @ 200° SSW
Direct Radiation (TLD)	16	Lakeview Road (84)	1.1 mi @ 225° SW
Direct Radiation (TLD)	17	Site Meteorological Tower (7)	0.7 mi @ 250° WSW
Direct Radiation (TLD)	18	Energy Information Center (18)	0.4 mi @ 265° W

★ Map = See Figures 5.1-1 and 5.1-2



**NINE MILE POINT NUCLEAR STATION
RADIOLOGICAL ENVIRONMENTAL MONITORING PROGRAM
SAMPLING LOCATIONS**

**TABLE 5.1
(Continued)**

Type of Sample	★ Map Location	Collection Site (Env. Program No.)	Location
Direct Radiation (TLD)	19	North Shoreline (85)	0.2 mi @ 294° WNW
Direct Radiation (TLD)	20	North Shoreline (86)	0.1 mi @ 315° NW
Direct Radiation (TLD)	21	North Shoreline (87)	0.1 mi @ 341° NNW
Direct Radiation (TLD)	22	Hickory Grove (88)	4.5 mi @ 97° E
Direct Radiation (TLD)	23	Leavitt Road (89)	4.1 mi @ 111° ESE
Direct Radiation (TLD)	24	Rt. 104 (90)	4.2 mi @ 135° SE
Direct Radiation (TLD)	25	Rt. 51A (91)	4.8 mi @ 156° SSE
Direct Radiation (TLD)	26	Maiden Lane Road (92)	4.4 mi @ 183° S
Direct Radiation (TLD)	27	Co. Rt. 53 (93)	4.4 mi @ 205° SSW
Direct Radiation (TLD)	28	Co. Rt. 1 (94)	4.7 mi @ 223° SW
Direct Radiation (TLD)	29	Lake Shoreline (95)	4.1 mi @ 237° WSW
Direct Radiation (TLD)	30	Phoenix, NY Control (49)	19.8 mi @ 163° S
Direct Radiation (TLD)	31	S. W. Oswego, Control (14)	12.6 mi @ 226° SW
Direct Radiation (TLD)	32	Scriba, NY (96)	3.6 mi @ 199° SSW
Direct Radiation (TLD)	33	Alcan Aluminum, Rt. 1A (58)	3.1 mi @ 220° SW
Direct Radiation (TLD)	34	Lycoming, NY (97)	1.8 mi @ 143° SE
Direct Radiation (TLD)	35	New Haven, NY (56)	5.3 mi @ 123° ESE
Direct Radiation (TLD)	36	W. Boundary, Bible Camp (15)	0.9 mi @ 237° WSW
Direct Radiation (TLD)	37	Lake Road (98)	1.2 mi @ 101° E
Surface Water	38	OSS Inlet Canal (NA)	7.6 mi @ 235° SW
Surface Water	39	JAFNPP Inlet Canal (NA)	0.5 mi @ 70° ENE

(NA) = Not applicable

★ Map = See Figures 5.1-1 and 5.1-2



10
11
12

**NINE MILE POINT NUCLEAR STATION
RADIOLOGICAL ENVIRONMENTAL MONITORING PROGRAM
SAMPLING LOCATIONS**

**TABLE 5.1
(Continued)**

Type of Sample	★ Map Location	Collection Site (Env. Program No.)	Location
Shoreline Sediment	40	Sunset Bay Shoreline (NA)	1.5 mi @ 80° E
Fish	41	NMP Site Discharge Area (NA)	0.3 mi @ 315° NW
Fish	42	NMP Site Discharge Area (NA)	(and/or) 0.6 mi @ 55° NE
Fish	43	Oswego Harbor Area (NA)	6.2 mi @ 235° SW
Milk	44	Milk Location #50	8.2 mi @ 93° E
Milk	45	Milk Location #7	5.5 mi @ 107° ESE
Milk	47	Milk Location #65	17.0 mi @ 220° SW
Milk	64	Milk Location #55	9.0 mi @ 95° E
Milk	65	Milk Location #60	9.5 mi @ 90° E
Milk	66	Milk Location #4	7.8 mi @ 113° ESE
Milk (CR)	73	Milk Location (Woodworth)	13.9 mi @ 234° SW
Food Product	48	Produce Location #6★★ (Bergenstock) (NA)	1.9 mi @ 141° SE
Food Product	49	Produce Location #1★★ (Culeton) (NA)	1.7 mi @ 96° E
Food Product	50	Produce Location #2★★ (Vitulfo) (NA)	1.9 mi @ 101° E
Food Product	51	Produce Location #5★★ (C.S. Parkhurst) (NA)	1.5 mi @ 114° ESE
Food Product	52	Produce Location #3★★ (C. Narewski) (NA)	1.6 mi @ 84° E

- * = The Jones milk location has been deleted due to the herd being sold. (Map location #46.)
- ★ Map = See Figures 5.1-1 and 5.1-2
- ★★ = Food Product Samples need not necessarily be collected from all listed locations. Collected samples will be of the highest calculated site average D/Q.
- (NA) = Not applicable
- CR = Control Result (location)



**NINE MILE POINT NUCLEAR STATION
RADIOLOGICAL ENVIRONMENTAL MONITORING PROGRAM
SAMPLING LOCATIONS**

**TABLE 5.1
(Continued)**

Type of Sample	★ Map Location	Collection Site (Env. Program No.)	Location
Food Product	53	Produce Location #4★★ (P. Parkhurst) (NA)	2.1 mi @ 110° ESE
Food Product (CR)	54	Produce Location #7★★ (Mc Millen) (NA)	15.0 mi @ 223° SW
Food Product (CR)	55	Produce Location #8** (Denman) (NA)	12.6 mi @ 225° SW
Food Product	56	Produce Location #9** (O'Connor) (NA)	1.6 mi @ 171° S
Food Product	57	Produce Location #10** (C. Lawton) (NA)	2.2 mi @ 123° ESE
Food Product	58	Produce Location #11** (C. R. Parkhurst) (NA)	2.0 mi @ 112° ESE
Food Product	59	Produce Location #12** (Barton) (NA)	1.9 mi @ 115° ESE
Food Product (CR)	60	Produce Location #13** (Flack) (NA)	15.6 mi @ 225° SW
Food Product	61	Produce Location #14** (Koeneke) (NA)	1.9 mi @ 95° E
Food Product	62	Produce Location #15** (Whaley) (NA)	1.7 mi @ 136° SE
Food Product	63	Produce Location #16** (Murray) (NA)	1.2 mi @ 207° SSW
Food Product	67	Produce Location #17** (Battles)	1.76 mi @ 97° E

★ Map = See Figures 5.1-1 and 5.1-2

★★ = Food Product Samples need not necessarily be collected from all listed locations. Collected samples will be of the highest calculated site average D/Q.

(NA) = Not applicable

CR = Control Result (location)



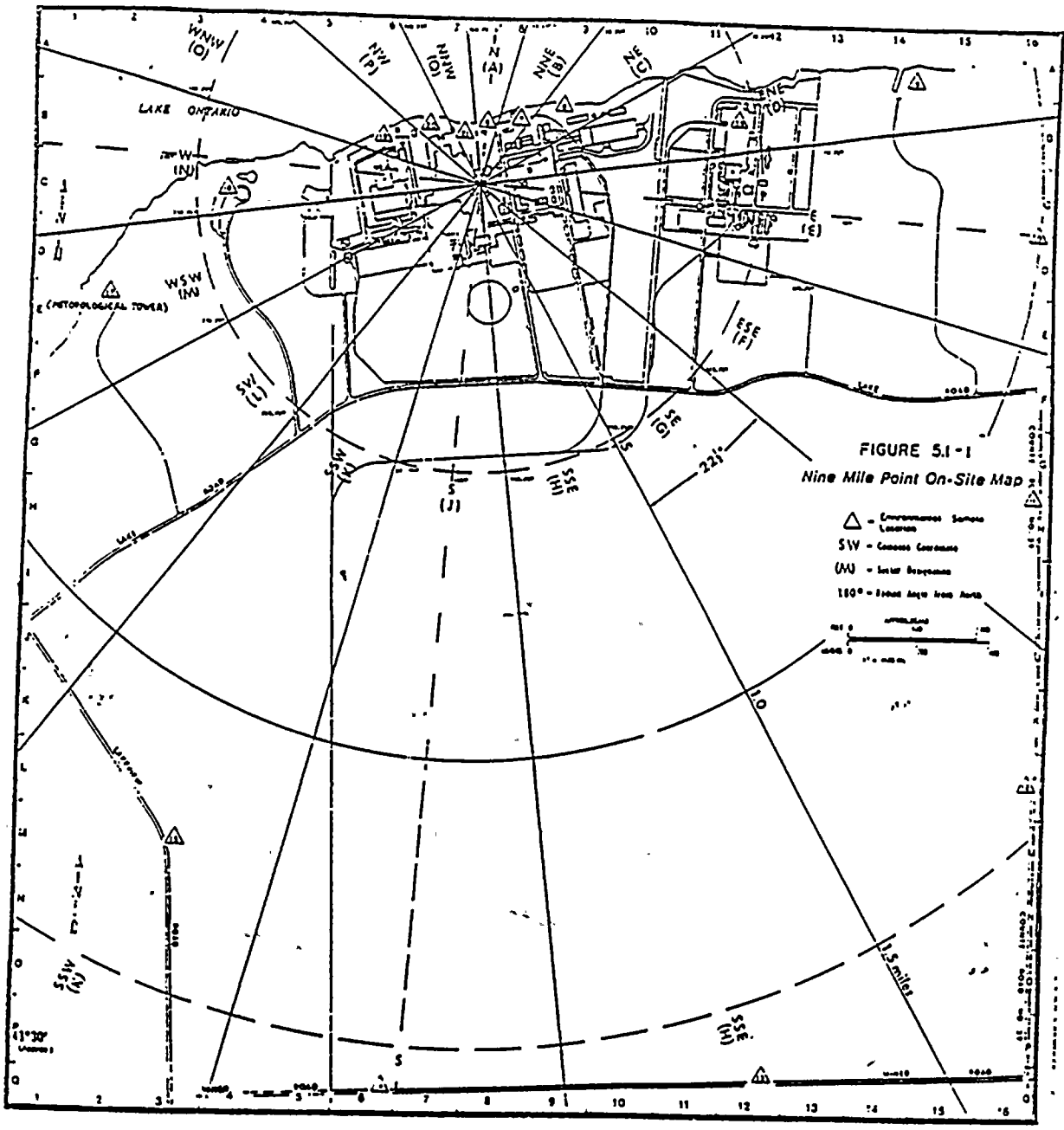
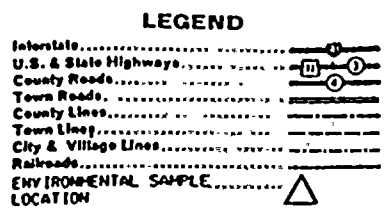
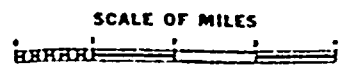

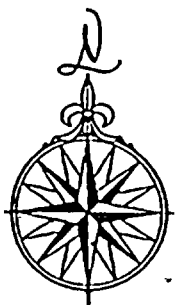

FIGURE 5.1-2 NINE MILE POINT OFF-SITE MAP (12/95)

Unit 1 ODCM
Revision 17
June 1996



Latitude 43°28'N
Longitude 76°30'W
at Oswego County Bldg., Oswego, NY
Land Area 968 Square miles



L A K E
O N T A R I O

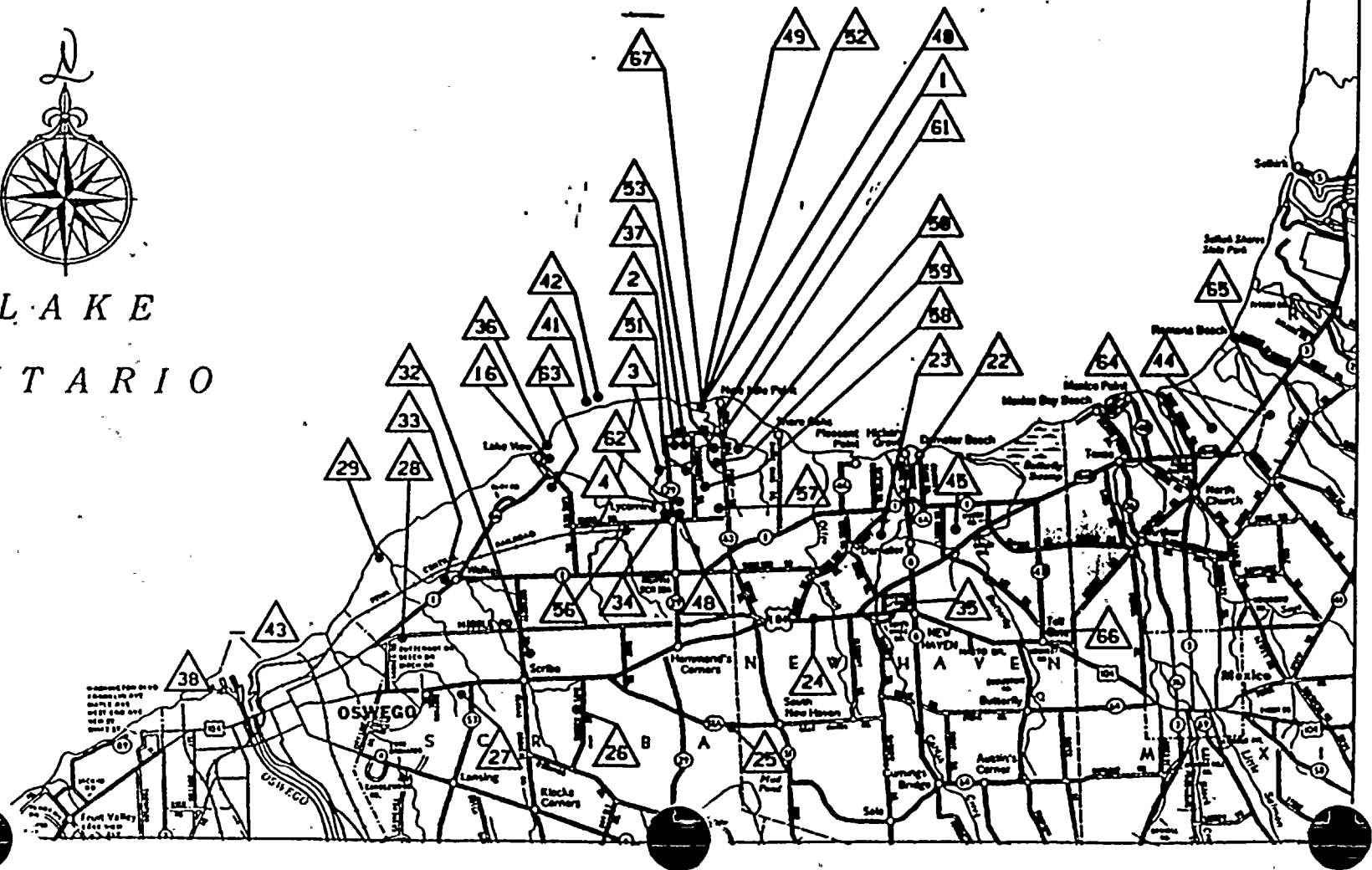

12/22/82







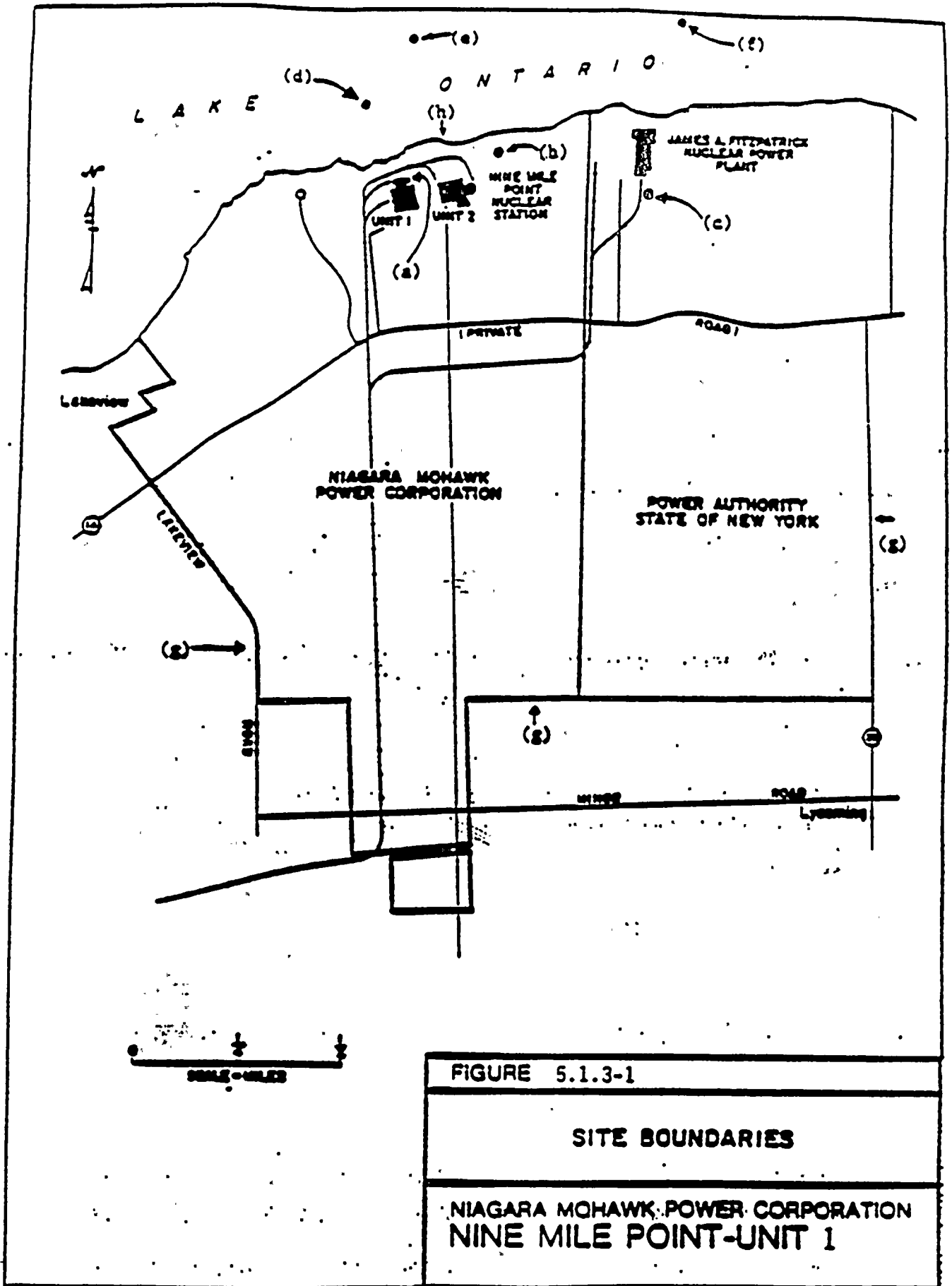



APPENDIX A
LIQUID DOSE FACTOR DERIVATION



Appendix A

Liquid Effluent Dose Factor Derivation, A_{iat}

A_{iat} (mrem/hr per $\mu\text{Ci/ml}$) which embodies the dose conversion factors, pathway transfer factors (e.g., bioaccumulation factors), pathway usage factors, and dilution factors for the points of pathway origin takes into account the dose from ingestion of fish and drinking water and the sediment. The total body and organ dose conversion factors for each radionuclide will be used from Table E-11 of Regulatory Guide 1.109. To expedite time, the dose is calculated for a maximum individual instead of each age group. The maximum individual dose factor is a composite of the highest dose factor A_{iat} of each nuclide i age group a , and organ t , hence A_{iat} . It should be noted that the fish ingestion pathway is the most significant pathway for dose from liquid effluents. The water consumption pathway is included for consistency with NUREG 0133.

The equation for calculating dose contributions given in section 1.3 requires the use of the composite dose factor A_{iat} for each nuclide, i . The dose factor equation for a fresh water site is:

$$A_{iat} = K_o \left[\frac{U_w (e^{-\lambda_i t_{pw}})}{D_w} \right] + U_f (BF)_i (e^{-\lambda_i t_{pf}}) (DFL)_{ia} + \dots$$

$$\dots + \frac{69.3 U_w}{(D_s) (\lambda_i)} e^{-\lambda_i t_{pw}} (1 - e^{-\lambda_i t_b}) (DFS)_i$$

Where:

- A_{iat} = Is the dose factor for nuclide i , age group a , total body or organ t , for all appropriate pathways, (mrem/hr per $\mu\text{Ci/ml}$).
- K_o = Is the unit conversion factor, $1.14E5 = 1E6 \text{ pCi}/\mu\text{Ci} \times 1E3 \text{ ml/kg} \div 8760 \text{ hr/yr}$.
- U_w = Water consumption (l/yr); from Table E-5 of Reg. Guide 1.109.
- U_f = Fish consumption (Kg/yr); from Table E-5 of Reg. Guide 1.109.
- U_s = Sediment Shoreline Usage (hr/yr); from Table E-5 of Reg. Guide 1.109.
- $(BF)_i$ = Bioaccumulation factor for nuclide, i , in fish, (pCi/kg per pCi/l), from Table A-1 of Reg. Guide 1.109.
- $(DFL)_{ia}$ = Dose conversion factor for age, nuclide, i , group a , total body or organ t , (mrem/pCi); from Table E-11 of Reg. Guide 1.109.
- $(DFS)_i$ = Dose conversion factor for nuclide i and total body, from standing on contaminated ground (mem/hr per pCi/m²); from Table E-6 of Reg. Guide 1.109.
- D_w = Dilution factor from the near field area within one-quarter mile of the release point to the potable water intake for the adult water consumption. This is the Metropolitan Water Board, Onondaga County intake structure located west of the City of Oswego; (unitless).



Appendix A (Cont'd)

- D_s = Dilution factor from the near field area within one quarter mile of the release point to the shoreline deposit (taken at the same point where we take environmental samples 1.5 miles; unitless).
- 69.3 = conversion factor $.693 \times 100, 100 = K_c$ (L/kg-hr) $*40*24$ hr/day/.693 in L/m²-d, and K_c = transfer coefficient from water to sediment in L/kg per hour.
- t_{pw}, t_{pf}, t_{ps} = Average transit time required for each nuclide to reach the point of exposure for internal dose, it is the total time elapsed from release of the nuclides to either ingestion for water (w) and fish (f) or shoreline deposit (s), (hr).
- t_b = Length of time the sediment is exposed to the contaminated water, nominally 15 yrs (approximate midpoint of facility operating life), (hrs).
- λ_i = decay constant for nuclide i (hr⁻¹).
- W = Shore width factor (unitless) from Table A-2 of Reg. Guide 1.109.

Example Calculation

For I-131 Thyroid Dose Factor for an Adult from a Radwaste liquid effluents release:

$(DFS)_i$	=	2.80E-9	mrem/hr per pCi/m ²		
$(DFL)_{Li}$	=	1.95E-3	mrem/pCi	t_{pw}	= 30 hrs. (w = water)
BF_i	=	15	pCi/Kg per pCi/L	t_{pf}	= 24 hrs. (f = fish)
U_f	=	21	Kg/yr	t_b	= 1.314E5 hrs. (5.48E3 days)
D_w	=	40	unitless	U_w	= 730 L/yr
D_s	=	12	unitless	K_o	= 1.14E5 $\frac{(pCi/\mu Ci)(ml/kg)}{(hr/yr)}$
U_s	=	12	hr/yr	λ_i	= 3.61E-3hr ⁻¹
W	=	0.3			
t_{ps}	=	5.5	hrs (s = Shoreline Sediment)		

These values will yield an A_{Li} Factor of 6.79E4 mrem-ml per μ Ci-hr as listed in Table 2-4. It should be noted that only a limited number of nuclides are listed on Tables 2-1 to 2-8. These are the most common nuclides encountered in effluents. If a nuclide is detected for which a factor is not listed, then it will be calculated and included in a revision to the ODCM.

In addition, not all dose factors are used for the dose calculations. A maximum individual is used, which is a composite of the maximum dose factor of each age group for each organ as reflected in the applicable chemistry procedures.



APPENDIX B
PLUME SHINE DOSE FACTOR DERIVATION



APPENDIX B

For elevated releases the plume shine dose factors for gamma air (B_1) and whole body (V_1), are calculated using the finite plume model with an elevation above ground equal to the stack height. To calculate the plume shine factor for gamma whole body doses, the gamma air dose factor is adjusted for the attenuation of tissue, and the ratio of mass absorption coefficients between tissue and air. The equations are as follows:

$$\frac{\text{Gamma Air}}{B_1} = \sum \frac{K \mu_a E I_s}{R \theta V_s}$$

- Where:
- K^1 = conversion factor (see below for actual value).
 - μ_a = mass absorption coefficient (cm^2/g ; air for B_1 , tissue for V_1)
 - E = Energy of gamma ray per disintegration (Mev)
 - V_s = average wind speed for each stability class (s), m/s
 - R = downwind distance (site boundary, m)
 - θ = sector width (radians)
 - s = subscript for stability class
 - I_s = I function = $I_1 + kI_2$, for each stability class. (unitless, see Regulatory Guide 1.109)
 - k^2 = Fraction of the attenuated energy that is actually absorbed in air (see Regulatory Guide 1.109, see below for equation)

Whole Body

$$V_1 = 1.11 S_F B_1 e^{-\mu_a t_d}$$

- Where:
- t_d = tissue depth (g/cm^2)
 - S_F = shielding factor from structures (unitless)
 - 1.11 = Ratio of mass absorption coefficients between tissue and air.

Where all other parameters are defined above.

$$^1K = \text{conversion factor} = \frac{[3.7 \text{ E}10 \text{ dis}]}{\text{Ci-sec}} \frac{1.6 \text{ E-}6 \text{ erg}}{\text{Mev}} = .46$$

$$\frac{[1293 \text{ g}]}{\text{m}^3} \frac{[100 \text{ erg}]}{\text{g-rad}}$$

$$^2k = \frac{\mu - \mu_a}{\mu_a}$$

- Where:
- μ = mass attenuation coefficient (cm^2/g ; air for B_1 , tissue for V_1)
 - μ_a = defined above

11
12
13
14
15
16
17
18
19
20
21
22
23
24
25
26
27
28
29
30
31
32
33
34
35
36
37
38
39
40
41
42
43
44
45
46
47
48
49
50
51
52
53
54
55
56
57
58
59
60
61
62
63
64
65
66
67
68
69
70
71
72
73
74
75
76
77
78
79
80
81
82
83
84
85
86
87
88
89
90
91
92
93
94
95
96
97
98
99
100



APPENDIX B (Cont'd)

There are seven stability classes, A thru F. The percentage of the year that each stability class occurs is taken from the U-2 FSAR. From this data, a plume shine dose factor is calculated for each stability class and each nuclide, multiplied by its respective fraction and then summed.

The wind speeds corresponding to each stability class are, also, taken from the U-2 FSAR. To confirm the accuracy of these values, an average of the 12 month wind speeds for 1985, 1986, 1987 and 1988 was compared to the average of the FSAR values. The average wind speed of the actual data is equal to 6.78 m/s, which compared favorably to the FSAR average wind speed equal to 6.77 m/s.

The average gamma energies were calculated using a weighted average of all gamma energies emitted from the nuclide. These energies were taken from the handbook "Radioactive Decay Data Tables", David C. Kocher.

The mass absorption (μ_a) and attenuation (μ) coefficients were calculated by multiplying the mass absorption (μ_a/ρ) and mass attenuation (μ/ρ) coefficients given in the Radiation Health Handbook by the air density equal to 1.293 E-3 g/cc or the tissue density of 1 g/cc where applicable. The tissue depth is 5g/cm^2 for the whole body.

The downwind distance is the site boundary.

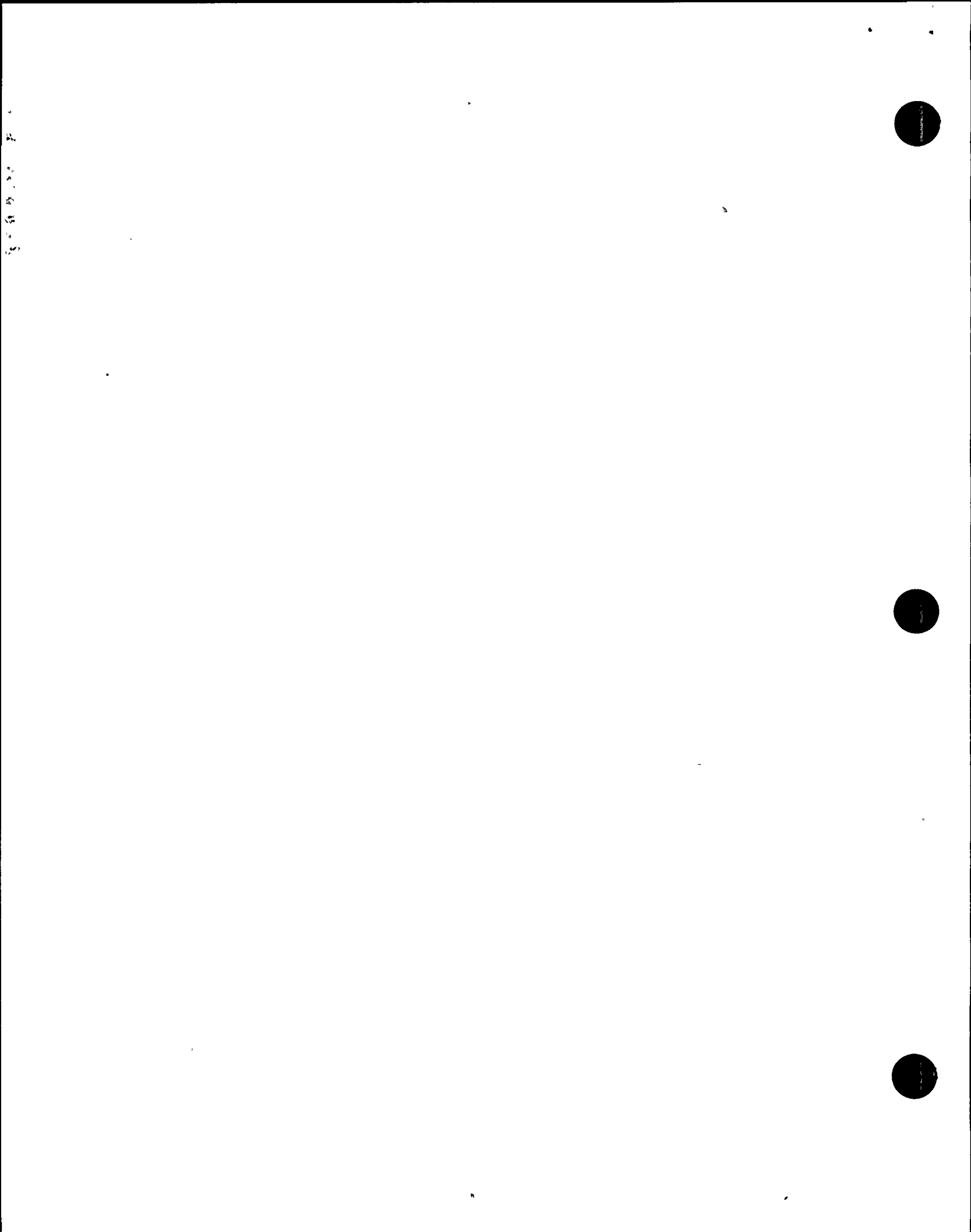

APPENDIX B (Cont'd)

SAMPLE CALCULATION

Ex. Kr-89

F STABILITY CLASS ONLY - Gamma Air

-DATA

$$\begin{aligned}
 E &= .2.22\text{MeV} & k &= \frac{\mu - \mu_a}{\mu_a} = .871 & K &= .46 \\
 \mu_a &= 2.943 \text{ E-}3\text{m}^{-1} & & & V_F &= 5.55 \text{ m/sec} \\
 \mu &= 5.5064\text{E-}3\text{m}^{-1} & R &= 644\text{m} & & \\
 \epsilon &= .39 & & & & \\
 \sigma_z &= 19\text{m} \dots \dots \text{vertical plume spread taken from "Introduction to Nuclear} \\
 & & & & & \text{Engineering", John R. LaMarsh}
 \end{aligned}$$

-I Function

$$\begin{aligned}
 U\sigma_z &= .06 \\
 I_1 &= .33 \\
 I_2 &= .45 \\
 I &= I_1 + kI_2 = .33 + (.871) (.45) = .72
 \end{aligned}$$

$$\begin{aligned}
 B_i &= \frac{0.46 \left[\frac{\text{dis.}}{\text{Ci-sec}} \right] (\text{Mev/ergs}) (2.943\text{E-}3\text{m}^{-1}) (2.22\text{MeV}) (.72)}{(\pi^2) (g/m^3) \left(\frac{\text{ergs}}{\text{g-rad}} \right) (5.55 \text{ m/s}) (.39) (644\text{m})} \\
 &= 1.55(-6) \frac{\text{rad/s} (3600 \text{ s/hr}) (24 \text{ h/d}) (365 \text{ d/y}) (1\text{E}3\text{mrad/rad})}{\text{Ci/s} \left(\frac{1\text{E}6\mu\text{Ci}}{\text{Ci}} \right)}
 \end{aligned}$$

$$= 2.76(-2) \frac{\text{mrad/yr}}{\mu\text{Ci/sec}}$$

$$V_i = 1.11 (.7) \left[2.76(-2) \frac{\text{mrad/yr}}{\mu\text{Ci/sec}} \right] \left[e^{-(.0253 \text{ cm}^2/\text{g}) (5\text{g/cm}^2)} \right]$$

$$= 1.89(-2) \frac{\text{mrad/yr}}{\mu\text{Ci/sec}}$$

NOTE: The above calculation is for the F stability class only. For Table 3-2 and procedure values, a weighted fraction of each stability class was used to determine the B_i and V_i values.



APPENDIX C

DOSE PARAMETERS FOR IODINE 131 and 133,
PARTICULATES AND TRITIUM



APPENDIX C

DOSE PARAMETERS FOR IODINE - 131 AND - 133, PARTICULATES AND TRITIUM

This appendix contains the methodology which was used to calculate the organ dose factors for I-131, I-133, particulates, and tritium. The dose factor, R_i , was calculated using the methodology outlined in NUREG-0133. The radioiodine and particulate Technical Specification (Section 3.6.15) is applicable to the location in the unrestricted area where the combination of existing pathways and receptor age groups indicates the maximum potential exposure occurs, i.e., the critical receptor. Washout was calculated and determined to be negligible. R_i values have been calculated for the adult, teen, child and infant age groups for all pathways. However, for dose compliance calculations, a maximum individual is assumed that is a composite of highest dose factor of each age group for each organ and pathway. The methodology used to calculate these values follows:

C.1 Inhalation Pathway

$$R_i(I) = K' (BR)_a (DFA)_{ija}$$

where:

$R_i(I)$ = dose factor for each identified radionuclide i of the organ of interest (units = mrem/yr per $\mu\text{Ci}/\text{m}^3$);

K' = a constant of unit conversion, $1\text{E}6 \text{ pCi}/\mu\text{Ci}$

$(BR)_a$ = Breathing rate of the receptor of age group a , (units = m^3/yr);

$(DFA)_{ija}$ = The inhalation dose factor for nuclide i , organ j and age group a , and organ t (units = mrem/pCi).

The breathing rates $(BR)_a$ for the various age groups, as given in Table E-5 of Regulatory Guide 1.109 Revision 1, are tabulated below.

<u>Age Group (a)</u>	<u>Breathing Rate (m^3/yr)</u>
Infant	1400
Child	3700
Teen	8000
Adult	8000

Inhalation dose factors $(DFA)_{ija}$ for the various age groups are given in Tables E-7 through E-10 of Regulatory Guide 1.109 Revision 1.



APPENDIX C (Cont'd)

C.2 Ground Plane Pathway

$$R_i(G) = \frac{K'K''(SF)(DFG)_i (1 - e^{-\lambda_i t})}{\lambda_i}$$

Where:

$R_i(G)$ = Dose factor for the ground plane pathway for each identified radionuclide i for the organ of interest (units = m^2 -mrem/yr per $\mu Ci/sec$)

K' = A constant of unit conversion, $1E6$ pCi/ μCi

K'' = A constant of unit conversion, 8760 hr/year

λ_i = The radiological decay constant for radionuclide i , (units = sec^{-1})

t = The exposure time, sec, $4.73E8$ sec (15 years)

$(DFG)_i$ = The ground plane dose conversion factor for radionuclide i ; (units = mrem/hr per pCi/ m^2)

SF = The shielding factor (dimensionless)

A shielding factor of 0.7 is discussed in Table E-15 of Regulatory Guide 1.109 Revision 1. A tabulation of $(DFG)_i$ values is presented in Table E-6 of Regulatory Guide 1.109 Revision 1.

50
8
7
13



APPENDIX C (Cont'd)

C.3 Grass-(Cow or Goat)-Milk Pathway

$$R_i(C) = \frac{K' Q_r (U_{rp}) F_m(r) (DFL)_{lat}}{(\lambda_i + \lambda_w)} \left[\frac{f_p f_s}{Y_p} + \frac{(1-f_p f_s)}{Y_s} (e^{-\lambda_i t_h}) \right] e^{-\lambda_i t_r}$$

Where:

- $R_i(C)$ = Dose factor for the cow milk or goat milk pathway, for each identified radionuclide i for the organ of interest, (units = m2-mrem/yr per $\mu\text{Ci}/\text{sec}$)
- K' = A constant of unit conversion, $1E6 \text{ pCi}/\mu\text{Ci}$
- Q_r = The cow's or goat's feed consumption rate, (units = Kg/day-wet weight)
- U_{rp} = The receptor's milk consumption rate for age group a , (units = liters/yr)
- Y_p = The agricultural productivity by unit area of pasture feed grass, (units = kg/m²)
- Y_s = The agricultural productivity by unit area of stored feed, (units = kg/m²)
- F_m = The stable element transfer coefficients, (units = pCi/liter per pCi/day)
- r = Fraction of deposited activity retained on cow's feed grass
- $(DFL)_{lat}$ = The ingestion dose factor for nuclide i , age group a , and total body or organ t (units = mrem/pCi)
- λ_i = The radiological decay constant for radionuclide i , (units=sec⁻¹)
- λ_w = The decay constant for removal of activity on leaf and plant surfaces by weathering equal to $5.73E-7 \text{ sec}^{-1}$ (corresponding to a 14 day half-life)
- t_r = The transport time from pasture to cow or goat, to milk, to receptor, (units = sec)
- t_h = The transport time from pasture, to harvest, to cow or goat, to milk, to receptor (units = sec)

1
2
3
4
5



APPENDIX C (Cont'd)

- f_p = Fraction of the year that the cow or goat is on pasture (dimensionless)
- f_s = Fraction of the cow feed that is pasture grass while the cow is on pasture (dimensionless)

Milk cattle and goats are considered to be fed from two potential sources, pasture grass and stored feeds. Following the development in Regulatory Guide 1.109 Revision 1, the value of f_p is considered unity in lieu of site specific information. The value of f_s is 0.5 based on 6 month grazing period. This value for f_s was obtained from the environmental group.

Table C-1 contains the appropriate values and their source in Regulatory Guide 1.109 Revision 1.

The concentration of tritium in milk is based on the airborne concentration rather than the deposition. Therefore, the $R_T(C)$ is based on X/Q :

$$R_T(C) = K'K'' F_m Q U_p (DFL)_{LW} 0.75(0.5/H)$$

Where:

- $R_T(C)$ = Dose factor for the cow or goat milk pathway for tritium for the organ of interest, (units = mrem/yr per $\mu\text{Ci}/\text{m}^3$)
- K'' = A constant of unit conversion, $1\text{E}3$ g/kg
- H = Absolute humidity of the atmosphere, (units = g/m^3)
- 0.75 = The fraction of total feed that is water
- 0.5 = The ratio of the specific activity of the feed grass water to the atmospheric water

Other values are given previously. A site specific value of H equal to $6.14 \text{ g}/\text{m}^3$ is used. This value was obtained from the environmental group using actual site data.

22
14
20
1972



C.4 Grass-Cow-Meat Pathway

$$R_i(C) = \frac{K'Q_i(U_{sp}) F_m(x) (DFL)_{iw}}{(\lambda_i + \lambda_w)} \left[\frac{f_p f_s}{Y_p} + \frac{(1-f_p f_s)}{Y_s} (e^{-\lambda_i t_b}) \right] e^{-\lambda_i t_r}$$

$R_i(M)$ = Dose factor for the meat ingestion pathway for radionuclide i for any organ of interest, (units = m^2 -mrem/yr per μ Ci/sec)

F_i = The stable element transfer coefficients, (units = pCi/kg per pCi/day)

U_{sp} = The receptor's meat consumption rate for age group a , (units = kg/year)

t_b = The transport time from harvest, to cow, to receptor, (units = sec)

t_r = The transport time from pasture, to cow, to receptor, (units = sec)

All other terms remain the same as defined for the milk pathway. Table C-2 contains the values which were used in calculating $R_i(M)$.

The concentration of tritium in meat is based on airborne concentration rather than deposition. Therefore, the $R_T(M)$ is based on X/Q .

$$R_T(M) = K'K''F_i Q U_{sp} (DFL)_{iw} [0.75(0.5/H)]$$

Where:

$R_T(M)$ = Dose factor for the meat ingestion pathway for tritium for any organ of interest, (units = mrem/yr per μ Ci/ m^3)

All other terms are defined above.

C.5 Vegetation Pathway

The integrated concentration in vegetation consumed by man follows the expression developed for milk. Man is considered to consume two types of vegetation (fresh and stored) that differ only in the time period between harvest and consumption, therefore:

$$R_i(V) = K' \frac{r}{Y_v(\lambda_i + \lambda_w)} (DFL)_{iw} \left[U^L F_L e^{-\lambda_i t_L} + U^S F_S e^{-\lambda_i t_S} \right]$$



APPENDIX C (Cont'd)

Where:

- $R_i(V)$ = Dose factor for vegetable pathway for radionuclide i for the organ of interest, (units = m^2 -mrem/yr per $\mu Ci/sec$)
- K' = A constant of unit conversion, $1E6$ pCi/ μCi
- U_a^L = The consumption rate of fresh leafy vegetation by the receptor in age group a , (units = kg/yr)
- U_a^S = The consumption rate of stored vegetation by the receptor in age group a (units = kg/yr)
- F_L = The fraction of the annual intake of fresh leafy vegetation grown locally
- F_s = The fraction of the annual intake of stored vegetation grown locally
- t_L = The average time between harvest of leafy vegetation and its consumption, (units = sec)
- t_h = The average time between harvest of stored vegetation and its consumption, (units = sec)
- Y_v = The vegetation areal P density, (units = kg/ m^2)

All other factors have been defined previously.

Table C-3 presents the appropriate parameter values and their source in Regulatory Guide 1.109 Revision 1.

In lieu of site-specific data, values for F_L and F_s of, 1.0 and 0.76, respectively, were used in the calculation. These values were obtained from Table E-15 of Regulatory Guide 1.109 Revision 1.

The concentration of tritium in vegetation is based on the airborne concentration rather than the deposition. Therefore, the $R_T(V)$ is based on X/Q :

$$R_T(V) = K'K'' [U_a^L f_L + U_a^S f_s] (DFL)_{LH} 0.75(0.5/H)$$

Where:

$$R_T(V) = \text{dose factor for the vegetable pathway for tritium for any organ of interest, (units = mrem/yr per } \mu Ci/m^3 \text{).}$$

All other terms are defined in preceding sections.



TABLE C-1

Parameters for Grass-(Cow or Goat)-Milk Pathways

<u>Parameter</u>	<u>Value</u>	<u>Reference</u> <u>(Reg. Guide 1.109 Rev. 1)</u>
Q_f (kg/day)	50 (cow) 6 (goat)	Table E-3 Table E-3
r	1.0 (radioiodines) 0.2 (particulates)	Table E-15 Table E-15
$(DFL)_{j_s}$ (mrem/pCi)	Each radionuclide	Tables E-11 to E-14
F_m (pCi/liter per pCi/day)	Each stable element	Table E-1 (cow) Table E-2 (goat)
Y_s (kg/m ²)	2.0	Table E-15
Y_p (kg/m ²)	0.7	Table E-15
t_b (seconds)	7.78×10^6 (90 days)	Table E-15
t_r (seconds)	1.73×10^5 (2 days)	Table E-15
U_{sp} (liters/yr)	330 infant 330 child 400 teen 310 adult	Table E-5 Table E-5 Table E-5 Table E-5



TABLE C-2

Parameters for the Grass-Cow-Meat Pathway

<u>Parameter</u>	<u>Value</u>	<u>Reference</u> <u>(Reg. Guide 1.109 Rev. 1)</u>
r	1.0 (radioiodines) 0.2 (particulates)	Table E-15 Table E-15
F_r (pCi/Kg per pCi/day)	Each stable element	Table E-1
U_{sp} (Kg/yr)	0 infant 41 child 65 teen 110 adult	Table E-5 Table E-5 Table E-5 Table E-5
$(DFL)_{ij}$ (mrem/pCi)	Each radionuclide	Tables E-11 to E-14
Y_p (kg/m ²)	0.7	Table E-15
Y_s (kg/m ²)	2.0	Table E-15
t_h (seconds)	7.78E6 (90 days)	Table E-15
t_r (seconds)	1.73E6 (20 days)	Table E-15
Q_r (kg/day)	50	Table E-3

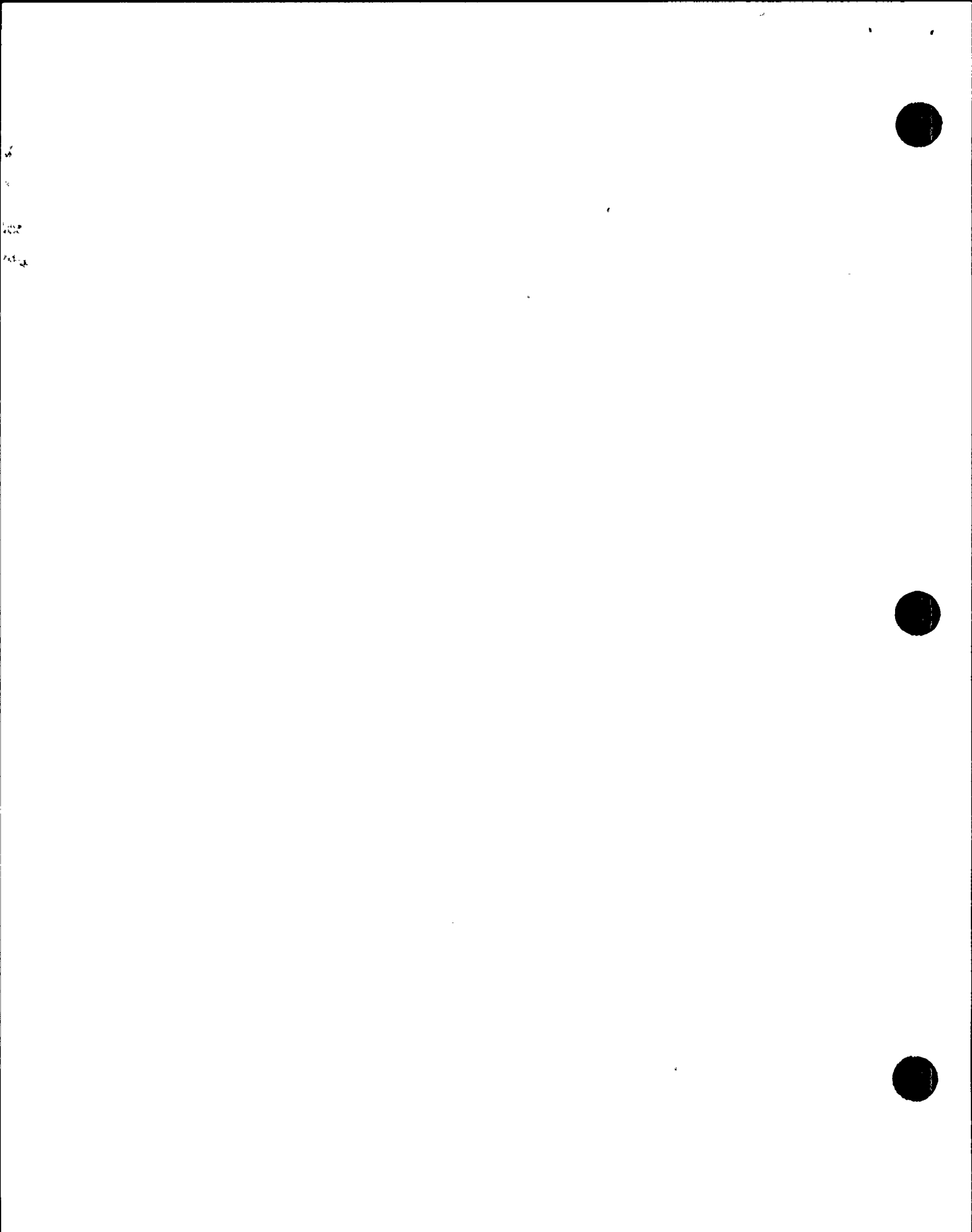

TABLE C-3

Parameters for the Vegetable Pathway

<u>Parameter</u>	<u>Value</u>	<u>Reference</u> (Reg. Guide 1.109 Rev. 1)
r (dimensionless)	1.0 (radioiodines) 0.2 (particulates)	Table E-1 Table E-1
$(DFL)_{y_a}$ (mrem/pCi)	Each radionuclide	Tables E-11 to E-14
U^L , (kg/yr) - infant	0	Table E-5
- child	26	Table E-5
- teen	42	Table E-5
- adult	64	Table E-5
U^I , (kg/yr) - infant	0	Table E-5
- child	520	Table E-5
- teen	630	Table E-5
- adult	520	Table E-5
t_L (seconds)	8.6E4 (1 day)	Table E-15
t_h (seconds)	5.18E6 (60 days)	Table E-15
Y_v (kg/m ²)	2.0	Table E-15



APPENDIX D

DIAGRAMS OF LIQUID AND GASEOUS TREATMENT SYSTEMS
AND
MONITORING SYSTEMS







MAIN CONDENSER AIR REMOVAL AND OFF GAS SYSTEM

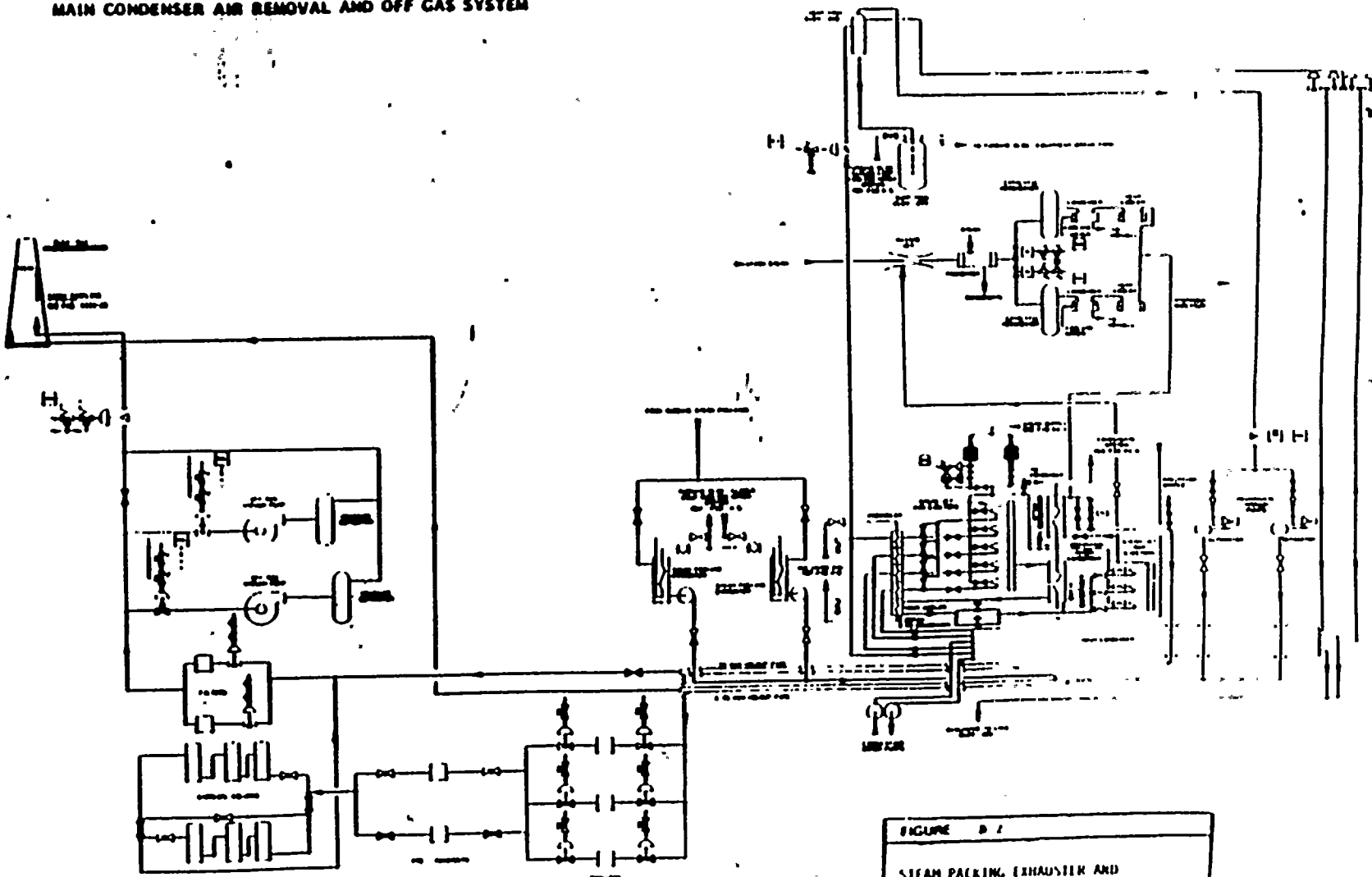

D-2

FIGURE D 2
STEAM PACKING EXHAUSTER AND
RECOMBINER SYSTEM
MAGLARA PALMISTONE PERMANEN GEMPANAN
NINE MILL POINT UNIT 1
OFF SITE DOSE CALC. MANUAL



REACTOR BUILDING VENTILATION SYSTEM

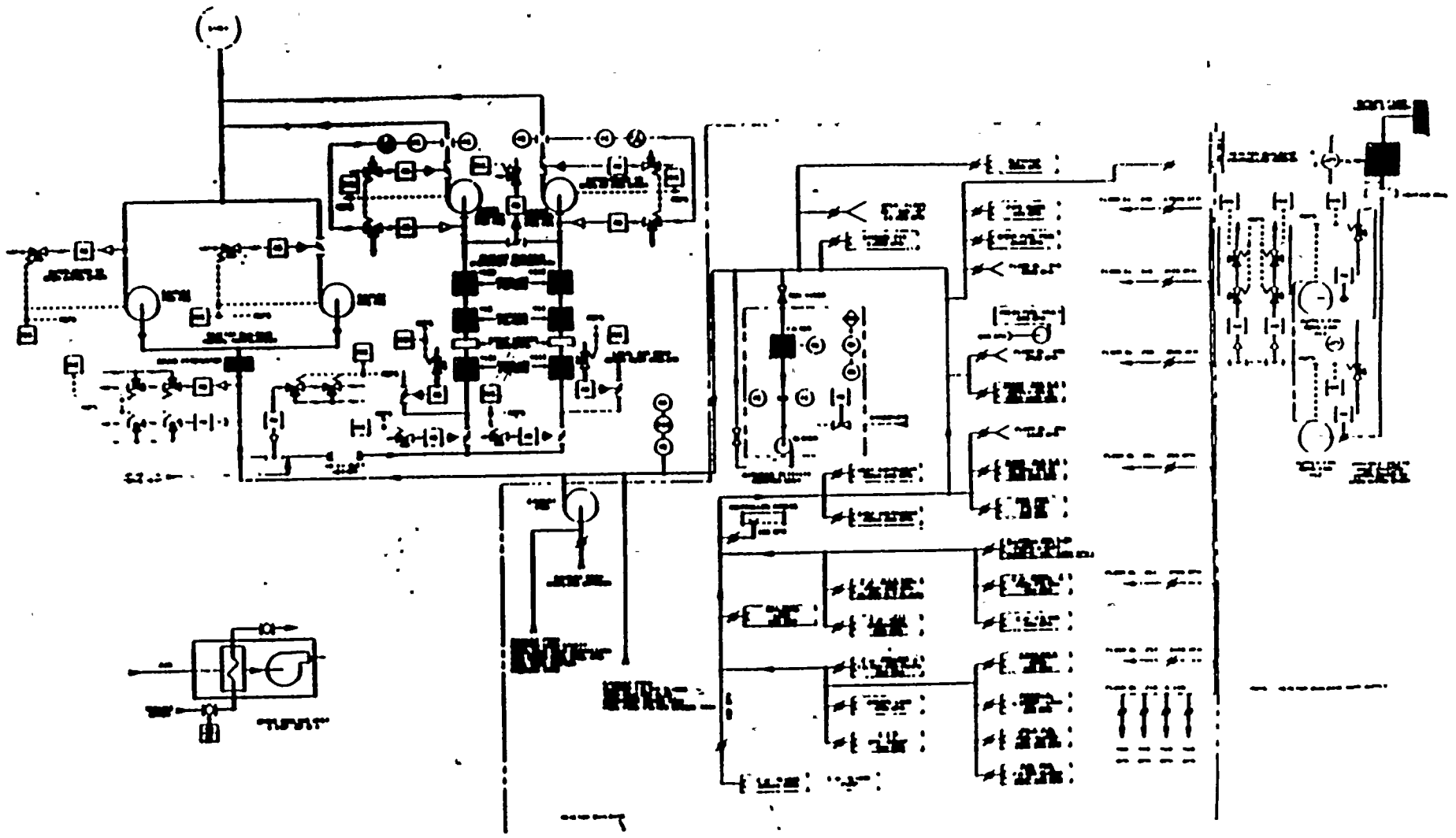

D-3

FIGURE D-1
REACTOR BUILDING VENTILATION SYSTEM
NIAGARA MOHAWK POWER CORPORATION
TINE MILE POINT UNIT 1
MUSKOGEE BASIN, CALIF.



WASTE DISPOSAL BUILDING VENTILATION SYSTEM

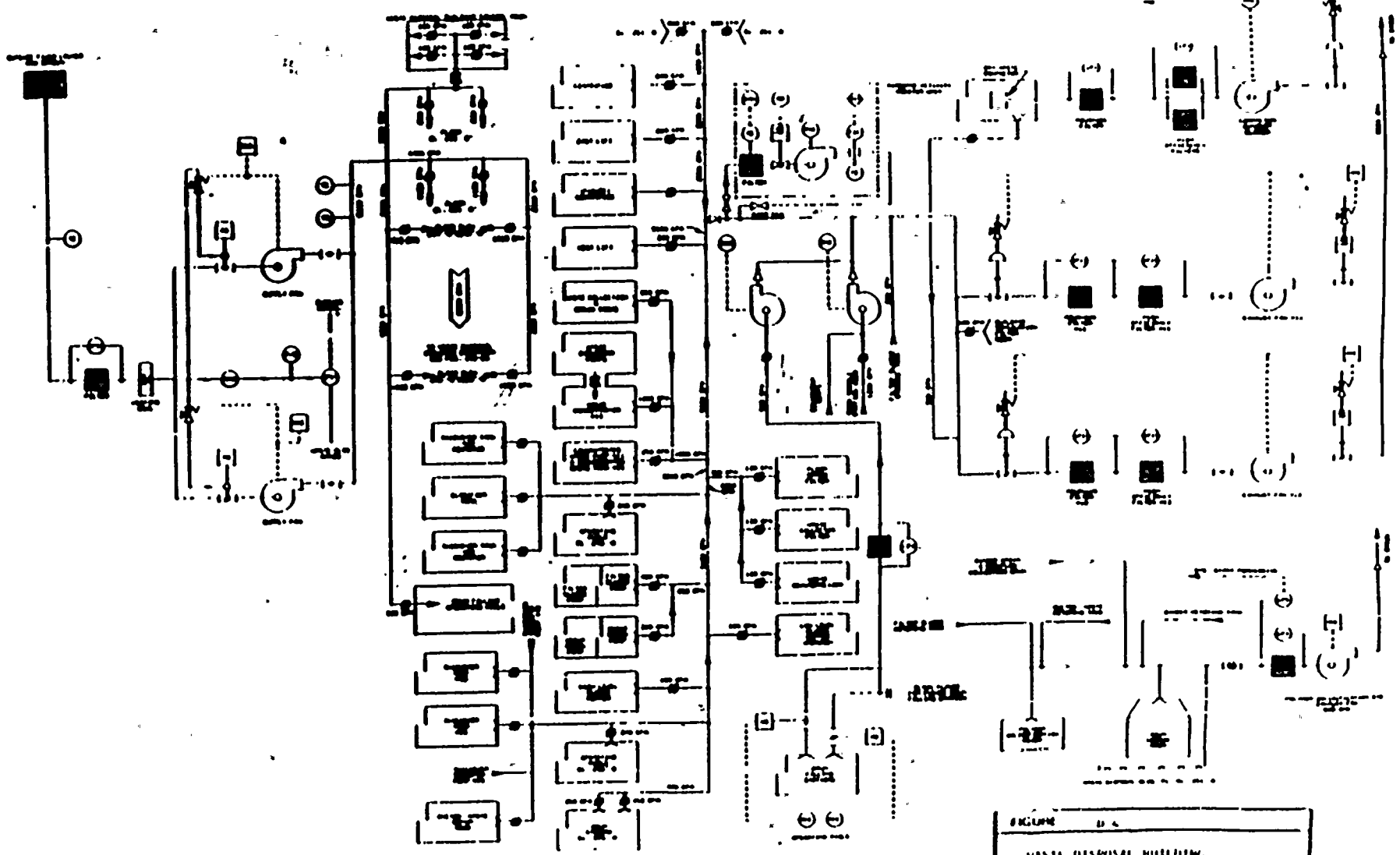

D-4

FIGURE D-4
 WASTE DISPOSAL BUILDING
 VENTILATION SYSTEM
 HANFORD ATOMARE POWER COMPLEX
 NINE MILE POINT UNIT 1
 OFF SITE DOSE CALC. MANUAL



STACK - PLAN AND ELEVATION

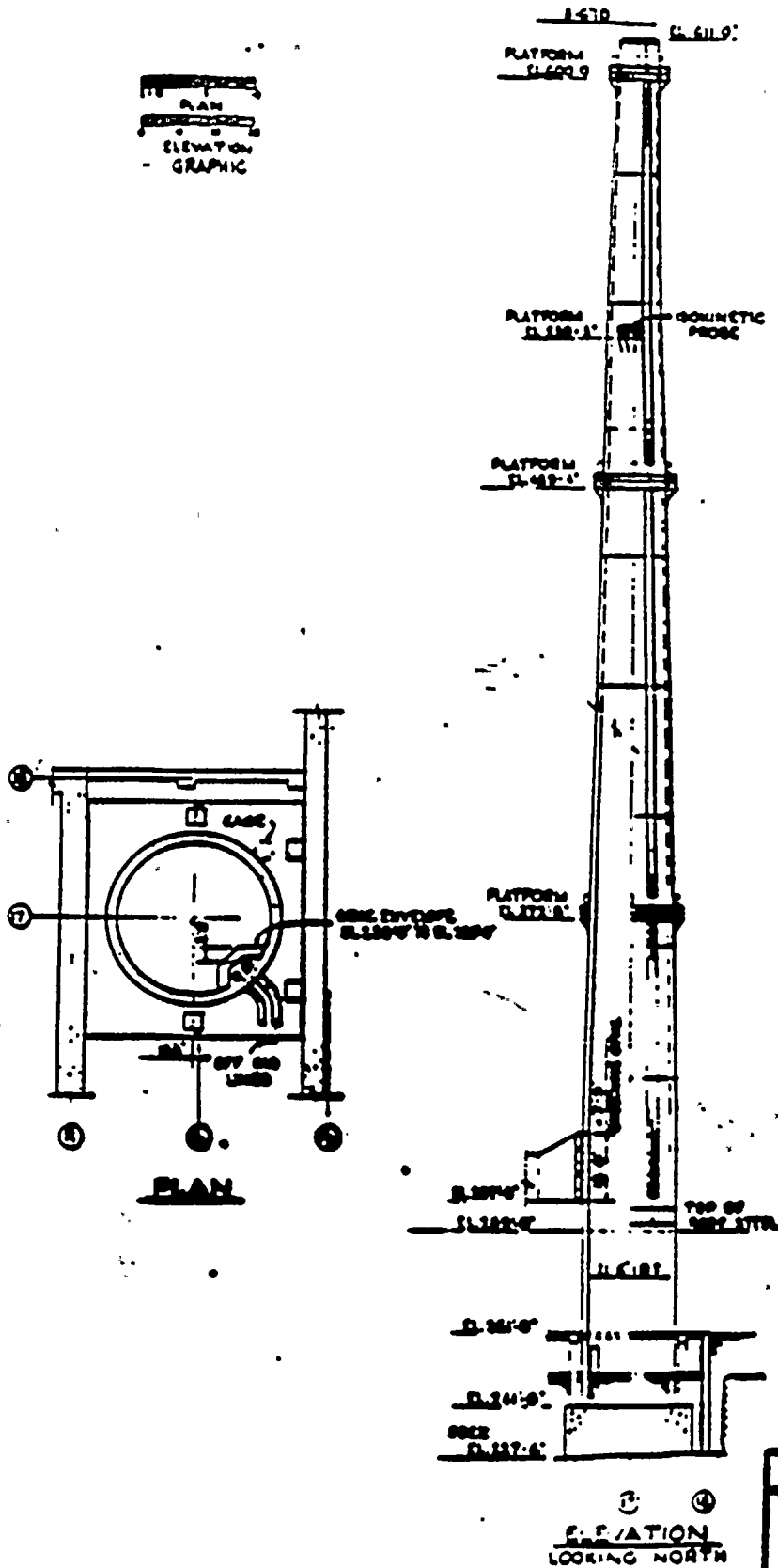

FIGURE D-5

100-1 Stack

NIAGARA MOHAWK POWER CORPORATION
NINE MILE POINT-UNIT 1
OFFSITE DOSE CALC. MANUAL



OFF GAS BUILDING VENTILATION SYSTEM

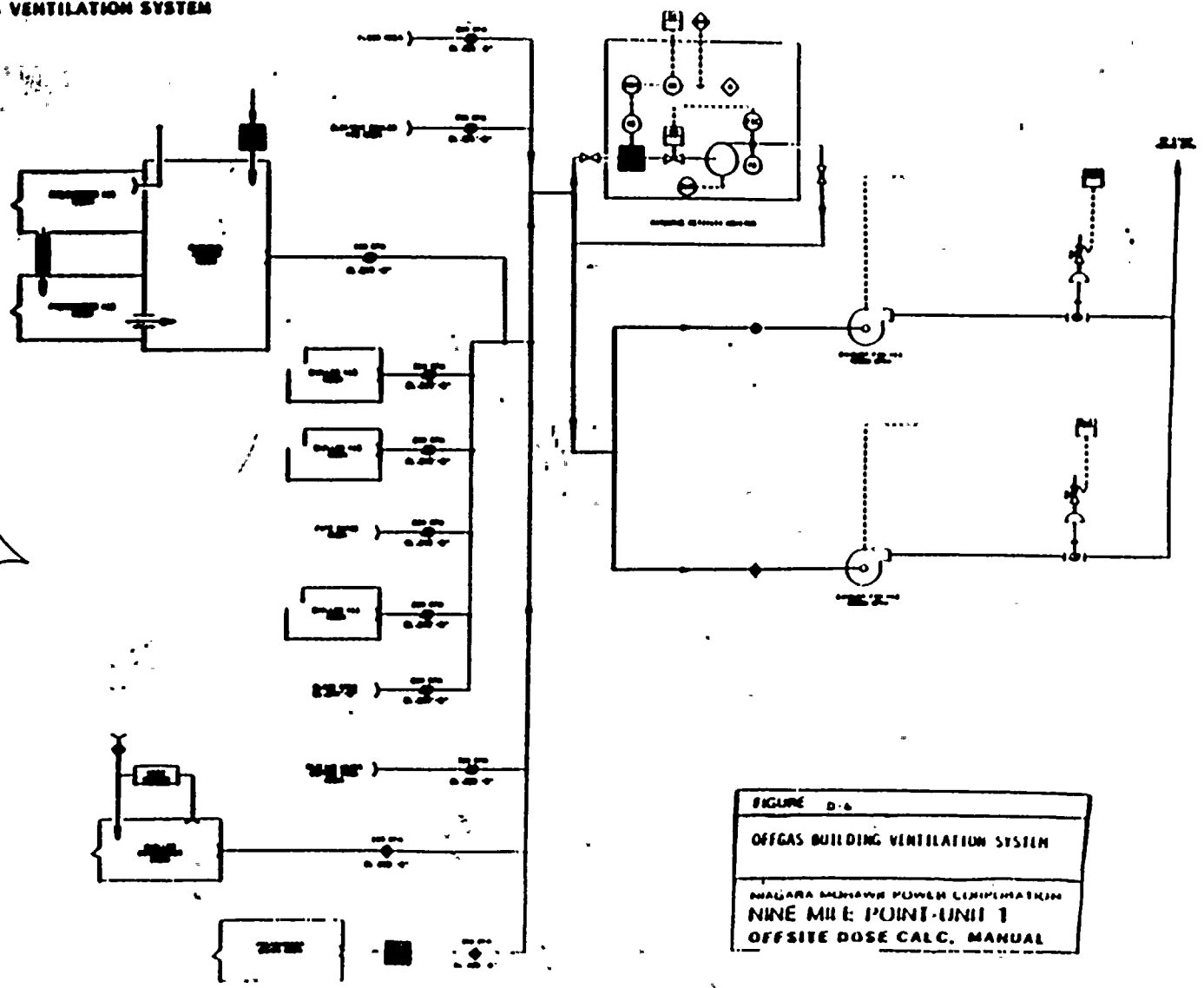

1000 L F M
NAGARA BUKU 000

FIGURE D-6
OFFGAS BUILDING VENTILATION SYSTEM
DAGARA MUMAW POWER CORPORATION
NINE MILE POINT-UNIT 1
OFFSITE DOSE CALC. MANUAL

D-6



D-7

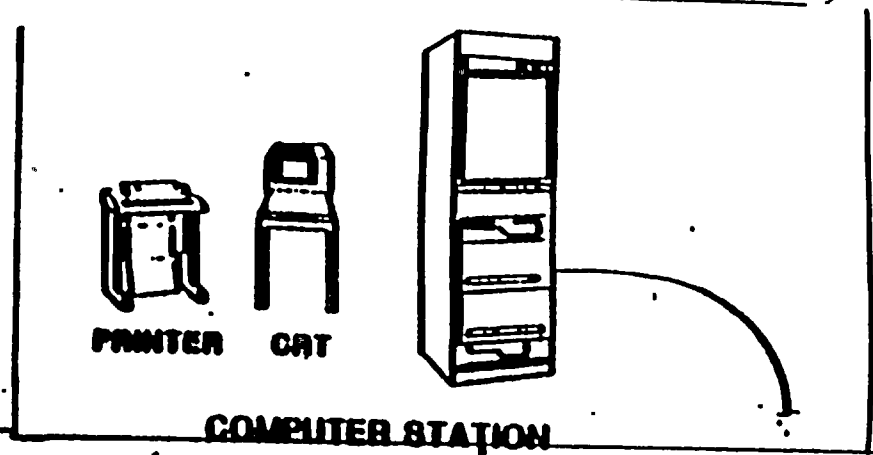
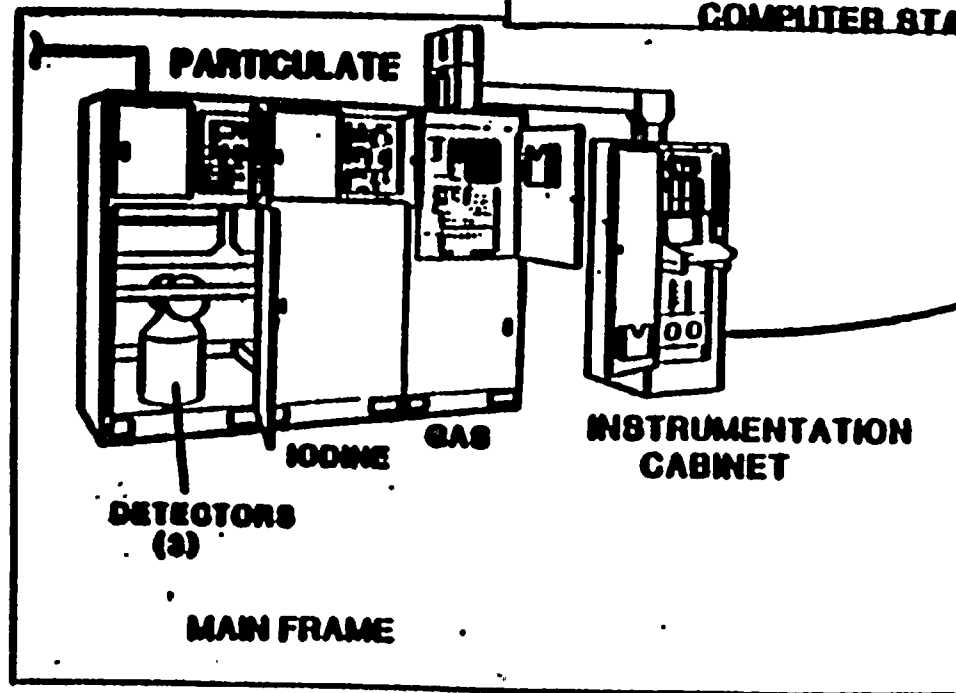
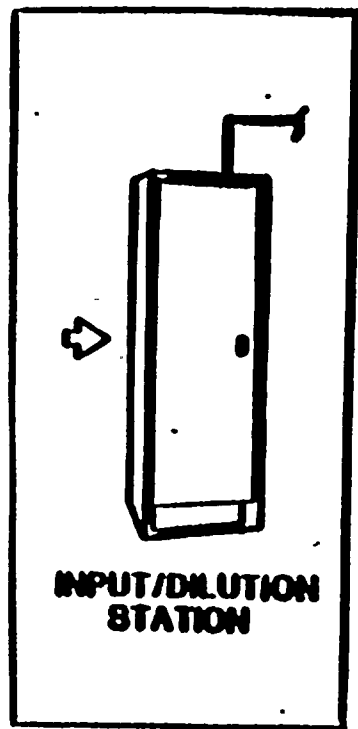

FIGURE D-7

Simplified View of Model 400 Stack Monitor

**NIAGARA MOHAWK POWER CORPORATION
NINE MILE POINT-UNIT 1**



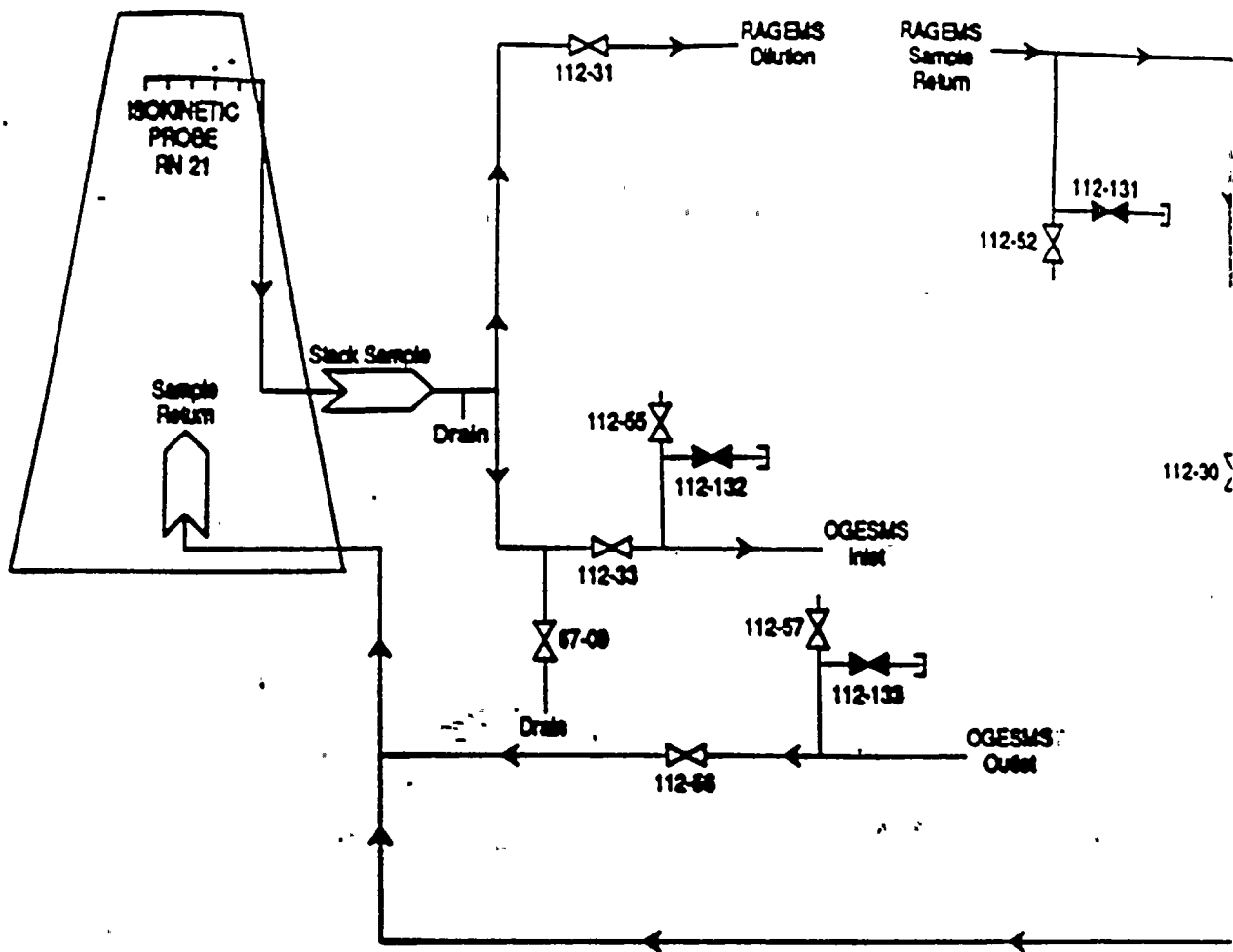

Figure D-8
Stack Sample and Sample Return
 NIAGARA MOHAWK POWER CORPORATION
 NINE MILE POINT - UNIT 1
 OFFSITE DOSE CALC. MANUAL



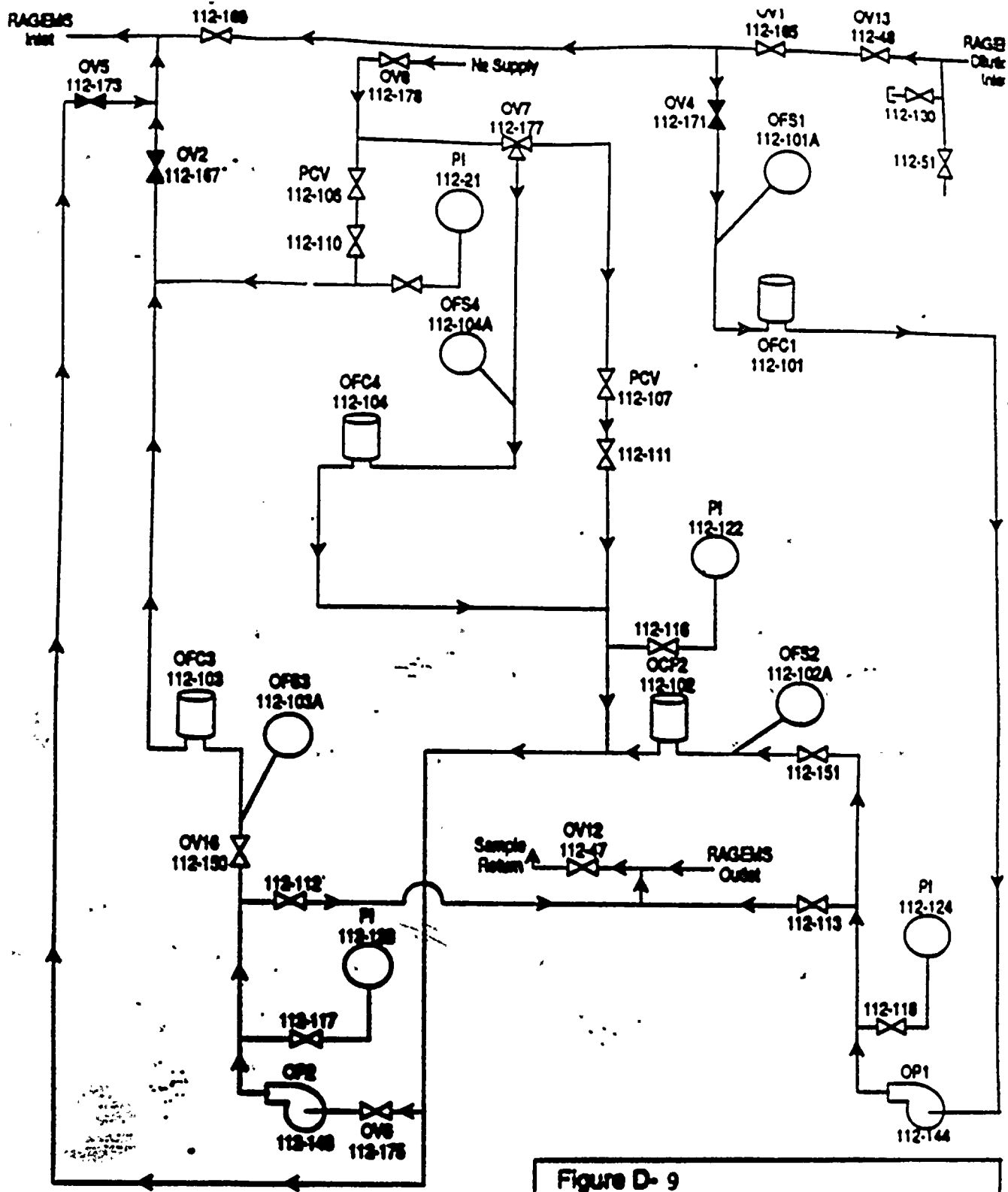

Figure D- 9
RAGEMS Dilution Schematic
 NIAGARA MOHAWK POWER CORPORATION
 NINE MILE POINT - UNIT 1
 OFFSITE DOSE CALC. MANUAL



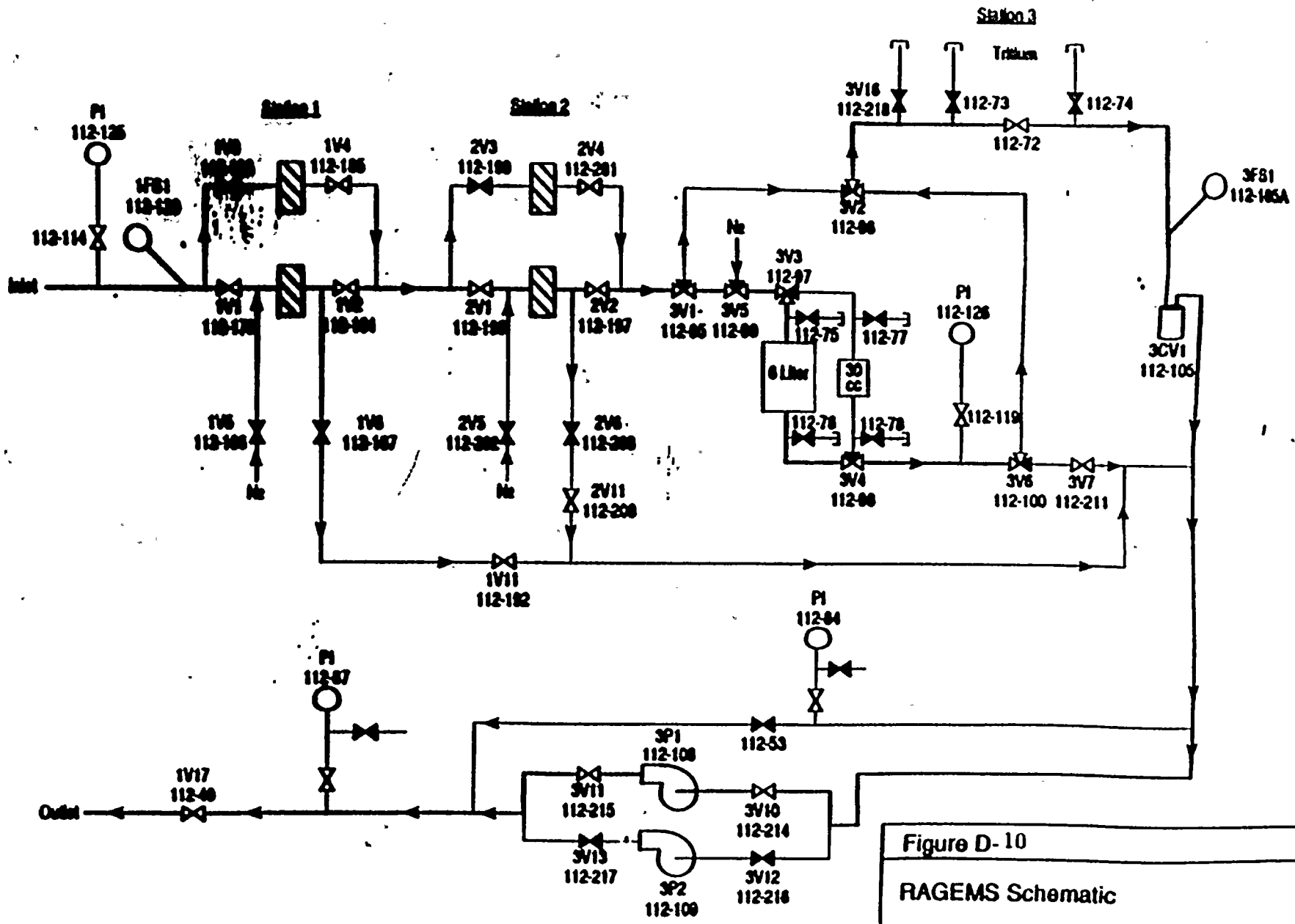

Figure D-10
RAGEMS Schematic
NIAGARA MOHAWK POWER CORPORATION
NINE MILE POINT - UNIT 1
OFFSITE DOSE CALC. MANUAL



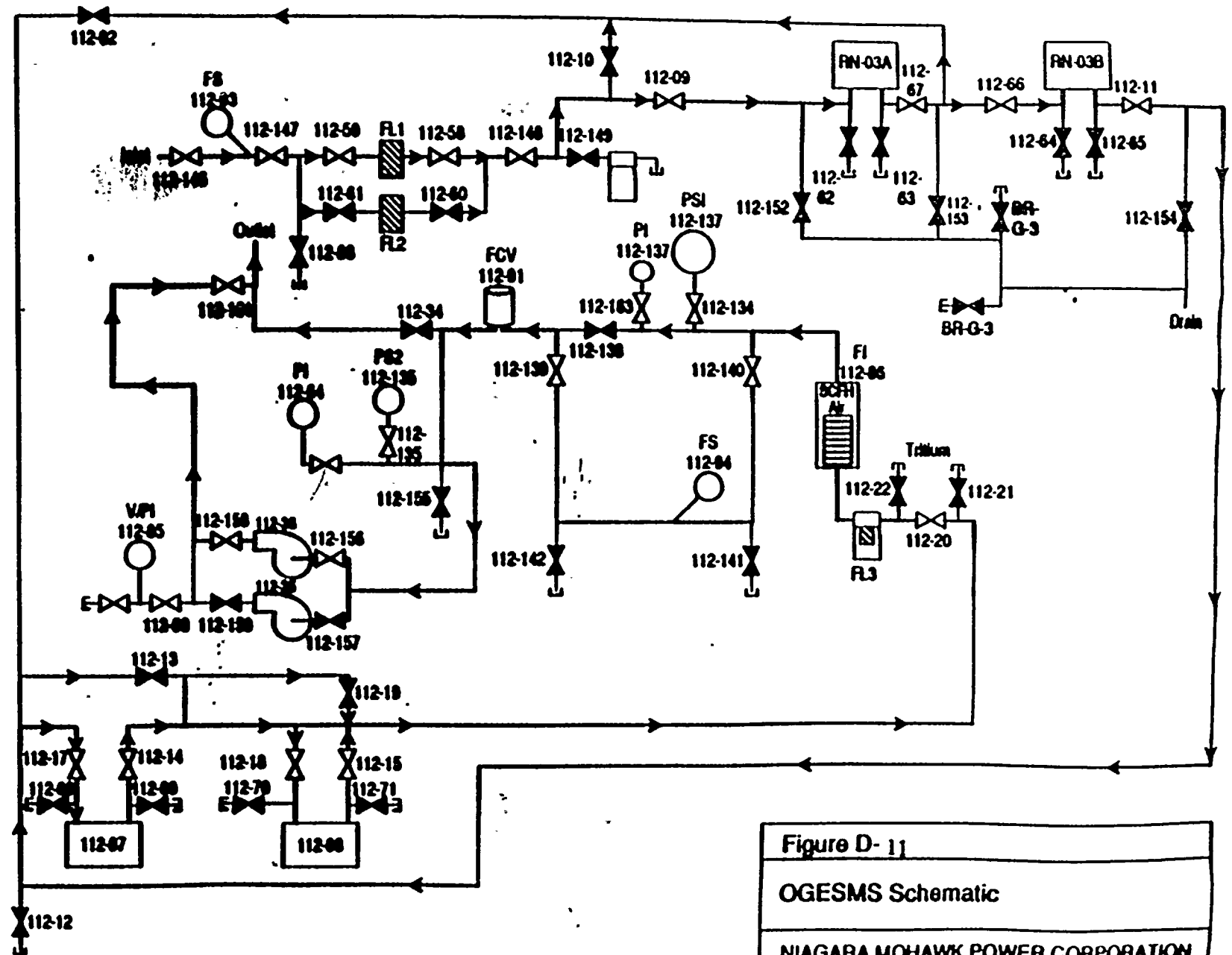

Figure D-11
 OGESMS Schematic
 NIAGARA MOHAWK POWER CORPORATION
 NINE MILE POINT - UNIT 1
 OFFSITE DOSE CALC. MANUAL

5. 1. 1971

