

REFERENCES:

- 0007.159-451-424 -F (CD-25-22)
- 2FWS-113 -2
- ESK-7FWS03 -4
- EE-4B -2
- FSK-6-10 -3
- 0007.520-001-538 -T (793E797 SH1)
- 0007.520-001-551 -L (793E797 SH14)
- EE-11AR -2
- 0007.520-001-549 -H (793E797 SH12)
- EE-3AF -5
- EE-3BN -4
- EE-3A -3
- 0007.520-001-539 -E (793E797 SH2)
- 0007.165-908-002 -B (E182095)
- LSK-6-1.1F -7
- 0007.510-414-135 -B (1097-6B25-0)
- EE-11AQ -2
- ECN FWS-508
- E4DCR C25087
- E4DCR P02291B

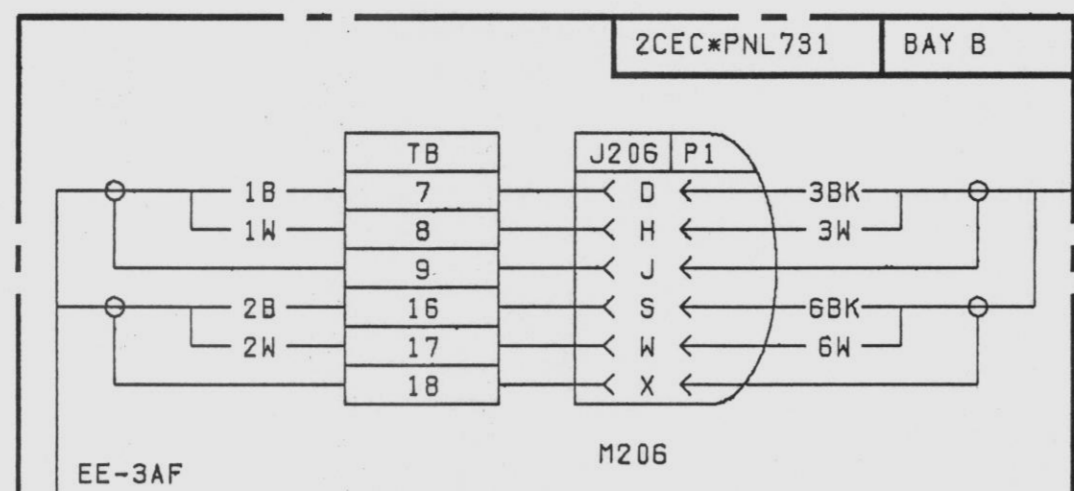

COL 10.7AG
EL 288'-6"

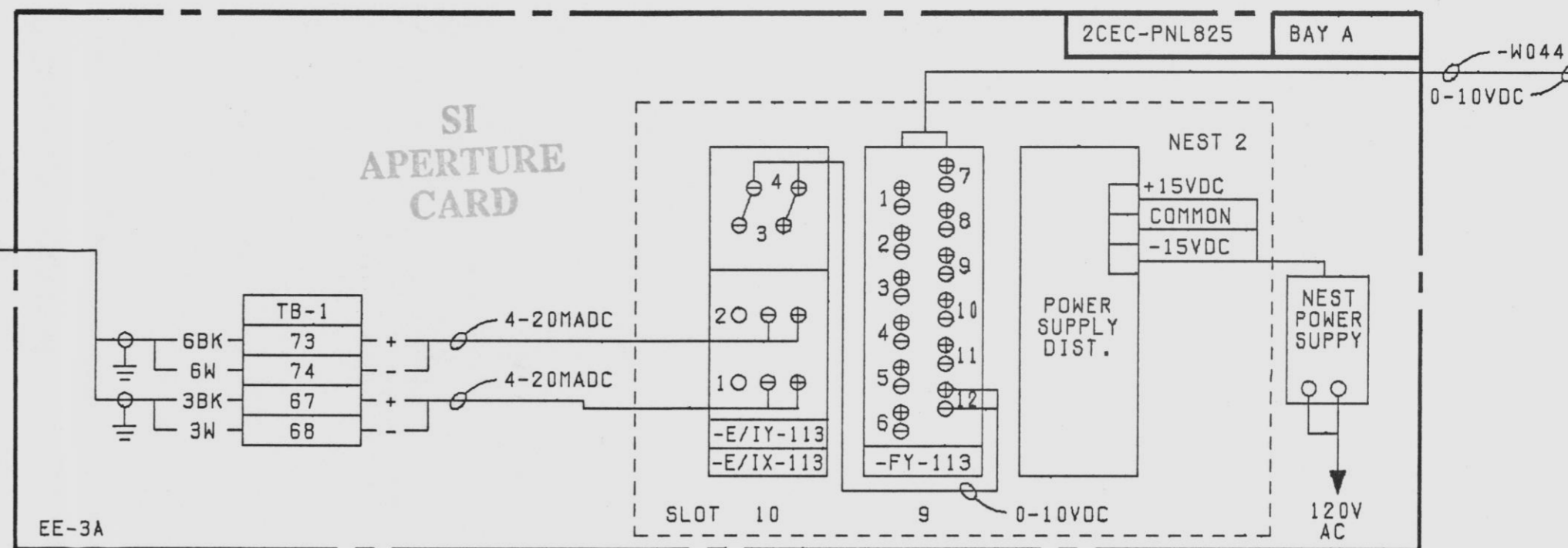

COL. 11.0AJ
EL. 288'-0"

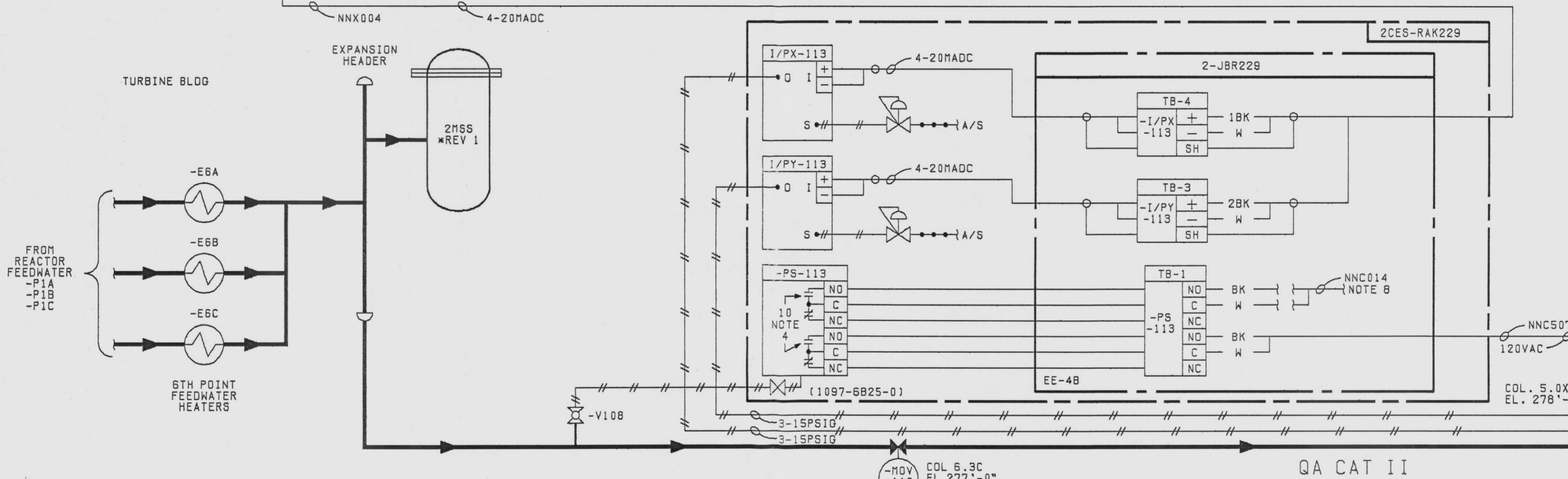

NOTES:

1. FOR TEST PURPOSES ONLY-NOT TO BE USED FOR CONSTRUCTION.
2. ALL INSTRUMENT AND EQUIPMENT NUMBERS ARE TO BE PREFIXED WITH "2FWS" EXCEPT WHERE A DIFFERENT PREFIX IS SHOWN.
3. LOOP ACTION: PS-113 MONITORS LOW ENERGY FEEDWATER CYCLE CLEAN UP PRESSURE AND ACTUATES ON HIGH PRESSURE TO DE-ENERGIZE SOVY-113 CLOSING HVY-113, TO DE-ENERGIZE SOVX-113 CLOSING HVX-113 AND TO CLOSE MOV-112. HIC-113 POSITIONS (ON NORMAL PRESSURE) HVX-113 VIA E/IX-113 AND I/PX-113, AND HVY-113 VIA E/IY-113 AND I/PY-113.
4. CONTACT CLOSURES ON HIGH PRESSURE TO CLOSE HVY-113 AND HVX-113.
5. 3-2FWSN10 ENERGIZES ON HIGH PRESSURE: CONTACT 3.4 OPENS TO DE-ENERGIZE SOVX-113, CONTACT 5.6 OPENS TO DE-ENERGIZE SOVY-113.
6. CONTACT OPENS WHEN VALVE IS FULL CLOSED.
7. CONTACT OPENS WHEN VALVE IS FULL OPEN.
8. TO 2NHS-MCC003, SEE TL2FWS-084.
9. 120VAC FROM 2SCI-PNL8101 CKT #24, VIA 2CEC-PNL751, BAYA.
10. CONTACT CLOSURES ON HIGH PRESSURE TO CLOSE MOV-112 SEE TL2FWS-084.

4	DATE PREPARED APPROVED	3	DATE PREPARED APPROVED	2	DATE PREPARED APPROVED	1	DATE 23APR84 PREPARED KRF/AWN APPROVED WJE	0	DATE 11MAY83 PREPARED WJE APPROVED LJM
---	------------------------	---	------------------------	---	------------------------	---	--	---	--

TEST LOOP DIAGRAM
LOW ENERGY FEEDWATER CYCLE CLEAN UP
2FWS-PS-113/ -HVY-113/ -HVX-113
NINE MILE POINT NUCLEAR STATION-UNIT 2
NIAGARA MOHAWK POWER CORPORATION

STONE & WEBSTER ENGINEERING CORPORATION
SHEET 1 OF 2
12177-TL2FWS-081

9305100055 D

CONTINUED ON SHT-2 FROM THIS DWG