

CMS ISOL V 2CMS * SOV60A
 OVERRIDE REQUIRED TO OPEN
 V AFTER AUTO. ISOLATION

CMS ISOL V 2CMS * SOV61A
 OVERRIDE REQUIRED TO OPEN
 V AFTER AUTO. ISOLATION

CMS ISOL V 2CMS * SOV62A
 OVERRIDE REQUIRED TO OPEN
 V AFTER AUTO. ISOLATION

CMS ISOL V 2CMS * SOV63A
 OVERRIDE REQUIRED TO OPEN
 V AFTER AUTO. ISOLATION

RX RECIRC LOOP A FCV HYDR ACTR
 LINE ISOL V 2RCS * SOV65A
 VALVE NORMALLY OPEN, CLOSE
 ON ISOLATION & RX SHUTDOWN

RX RECIRC LOOP A FCV HYDR
 ACTR LINE ISOL V 2RCS * SOV66A
 VALVE NORMALLY OPEN, CLOSE
 ON ISOLATION & RX SHUTDOWN

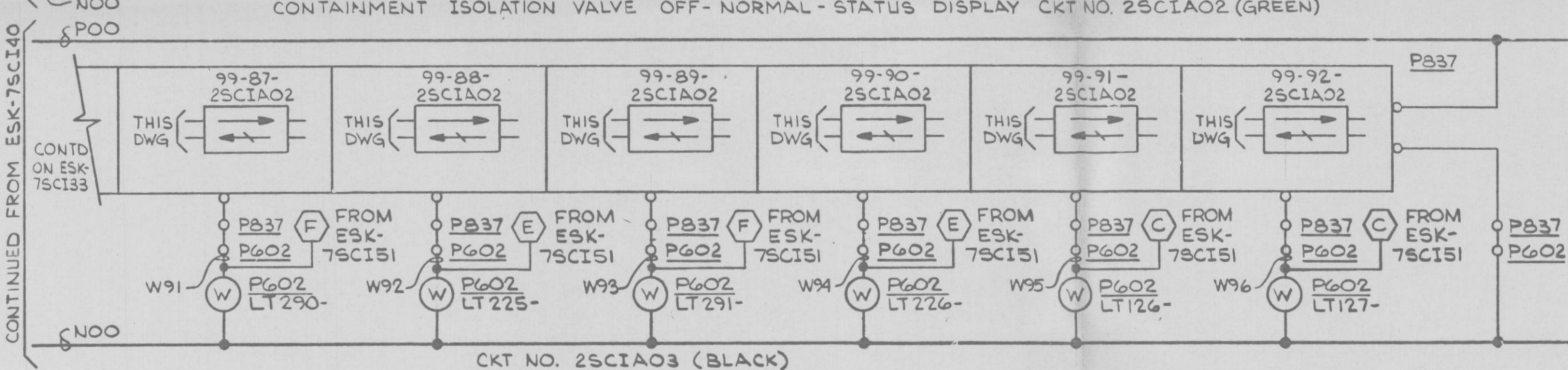
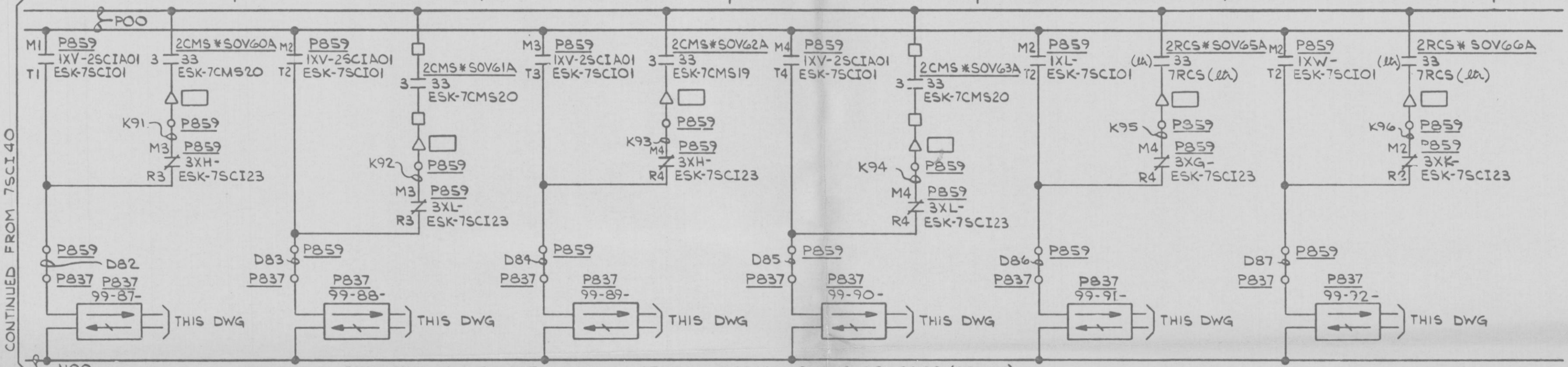

PRC
 APERTURE
 CARD

NOTES
 1. □ - INDICATES DRYWELL PENETRATION.

NUCLEAR SAFETY RELATED
 QA CAT I, II
 DC ELEM DIAG-MISC DC CKTS
 OFF-NORMAL STATUS DISPLAY
 NINE MILE POINT NUCLEAR STATION-UNIT 2
 NIAGARA MOHAWK POWER CORPORATION
 STONE & WEBSTER ENGINEERING CORPORATION

7	6	5	4	3	2	1
---	---	---	---	---	---	---

DESIGN CONTROL ISSUE
 12177-ESK-7SCI43
 JRM/EP

D