

LEUPA

Type B(U) Package for Fissile Materials

**ANALYSIS OF THE LEUPA PACKAGE
EXTERNAL PRESSURE**

Prepared by:

IN/AP

November 24, 2013

Page 1 of 12

REVISION SHEET		Document No.: 0908-LE02-3BEIN-004-A Revision: A			
		Document Title: Analysis of the LEUPA Package – External Pressure			
		Ref. No.:			
		Name, date, signature / initials			
Revision Letter	Description of the Revision	Prepared by	Reviewed by	Approved by	
A	Original	MW	NG	JCO	

CONTENTS

1	PURPOSE	4
2	SCOPE	4
3	APPLICABLE DOCUMENTS	4
4	REFERENCE DOCUMENTS	4
5	ABBREVIATIONS	4
6	DEVELOPMENT	4
6.1	DESCRIPTION OF THE PACKAGE	4
6.2	IMMERSION TEST	5
6.3	SIMPLIFYING HYPOTHESES	5
6.3.1	Model	5
6.3.2	Simplification of the Package	6
6.4	MESHING	6
7	MATERIALS	6
8	RESULTS	7
8.1	PRESSURE ON EXTERNAL WALLS	7
8.2	PRESSURE ON INTERNAL ASSEMBLY WALLS	9
8.2.1	Meshing of the Internal Assembly	10
8.2.2	Results of the Internal Assembly	10
9	CONCLUSIONS	12

1 PURPOSE

1. The purpose of this document is to evaluate the structural integrity of the LEUPA package subject to a load status caused by external pressure, as a result of immersion in water to a certain depth.

2 SCOPE

1. This document evaluates the behavior of the LEUPA package under external pressure. The study is focused solely on accidental conditions during transport.

3 APPLICABLE DOCUMENTS

- | | | | | |
|----|------|---|---------------------|-------------------------------------|
| 1. | APL1 | - | 0908-LE01-3AEIN-010 | "Main Body Packaging". |
| 2. | APL2 | - | 0908-LE01-3BEIN-024 | "LEUPA - Criticality Analysis" |
| 3. | APL3 | - | 0908-LE01-3AEIN-005 | "Container of Internal Containers". |
| 4. | APL4 | - | 0908-LE013AEIN-006 | "Cadmium Chamber". |

4 REFERENCE DOCUMENTS

- | | | | | |
|----|------|---|--|--|
| 1. | REF1 | - | ARN. <i>Transport of Radioactive Materials</i> . Standard AR 10.16.1. Rev. 2. Argentina: ARN (Nuclear Regulatory Authority), 2011. | |
| 2. | REF2 | - | ASME Boiler and Pressure Vessel Code, Section II, Part D. | |

5 ABBREVIATIONS

Abbreviation	Description
CM	Center of mass
FM	Fissile material
LEUPA	Low Enriched Uranium Package

6 DEVELOPMENT

6.1 Description of the Package

1. The package is designed for the transport of fissile material (FM), and shall be equipped to protect the cargo from accidental impacts and high outdoor temperatures.
2. In summary, the package is composed of a double-layer stainless steel interior container with cadmium between the layers. That is the container with the FM, sealed with a bolted cover.
3. There is an external 3 mm-thick stainless steel plate confinement. This containment is reinforced with L profiles and there are also 8 sheets with radial configuration to center the internal container. Empty spaces are filled with thermal insulation material called "kaolite".
4. APL1 contains a list of the elements of the package.

Figure 1: Internal view of the package

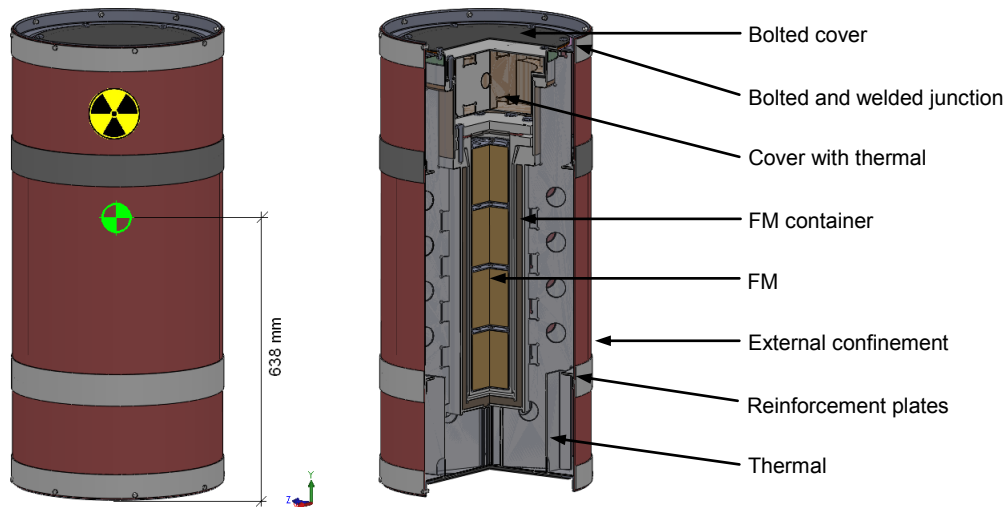

6.2 Immersion Test

1. One of the tests for the package is a test on the effect of external pressure equivalent to immersion in water to 200 m. That test is specified in REF1, paragraph 730.
2. The pressure equivalent to this immersion is that caused by a column of water at such depth, which can be calculated as:

$$P_e = \rho g H = 1000 \left[\frac{kg}{m^3} \right] \times 10 \left[\frac{m}{s^2} \right] \times 200 [m] = 2 [MPa]$$

3. Represented in Figure 2: the status of the load of the package, subject to external pressure.

Figure 2: External view of the package

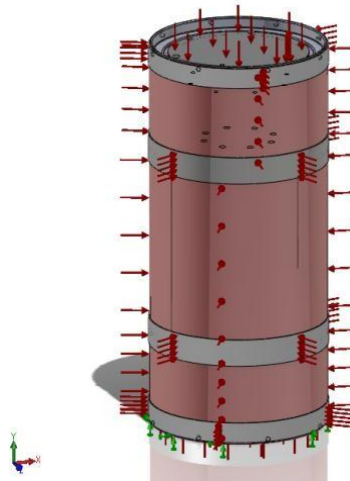

6.3 Simplifying Hypotheses

6.3.1 Model

1. The test was modeled with the finite elements method.

- It was assumed that pressure affects external layers of the components of the LEUPA, considering environment pressure remains constant on the inside.

6.3.2 Simplification of the Package

- To facilitate the meshing of the model, the details of some elements were simplified. These were replaced with circular section linear elements with the applicable diameter.
- The kaolite filling was not considered in simulations due to the complex geometry and because it has no structural role as regards the package.

Figure 3: Simplification of the model and meshing

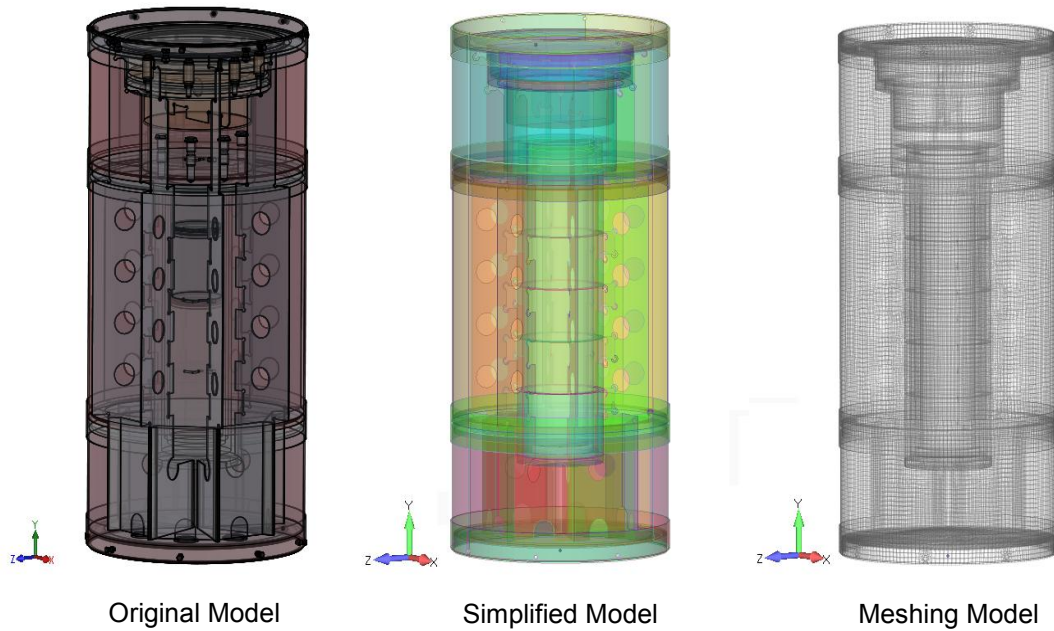

6.4 Meshing

- Shell elements were used, assigning the related thickness to each part. The container was meshed with an average element size of 10 mm, generating a mesh with 86596 nodes and 88751 rectangular elements.

7 MATERIALS

- According to the APL2 the approximate total mass of the package is 430 kg and can carry a useful load of 50 kg of FM. The materials of the package are those stated in Table 1:

Table 1: Materials obtained from APL2

Material	Approximate mass [kg]	Density [g/cm ³]
Metallic Uranium	50	18.9
Polyethylene	0.4	0.9
Kaolite 1600	85	0,405
AISI 304L	244	7.9
Cadmium	58	8.65

- The container is made of type 304L stainless steel, with the properties listed in Table 2:, obtained from REF2 (ASME II, Part D).

Table 2: Properties of 304L steel

Material	A312-TP304L
Modulus of Elasticity	192708 [MPa]
Tensile Strength	482.6 [MPa]
Yield Strength	172.3 [MPa]
Admissible Stress at 93°C	92.4 [MPa]
Density	7825 [kg/m ³]

8 RESULTS

8.1 Pressure on External Walls

- First, the package's behavior at a 2 MPa pressure in its external walls was tested. The results obtained are those presented in Figure 4:, Figure 5: and Figure 6:.

Figure 4: (External) Stresses in the package subject to external pressure

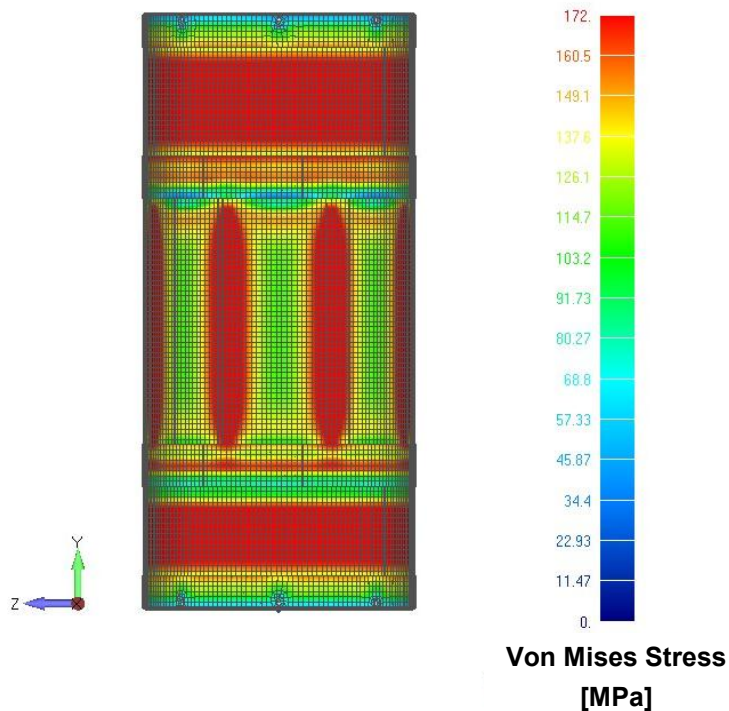

Figure 5: (Internal) Stresses in the package subject to external pressure

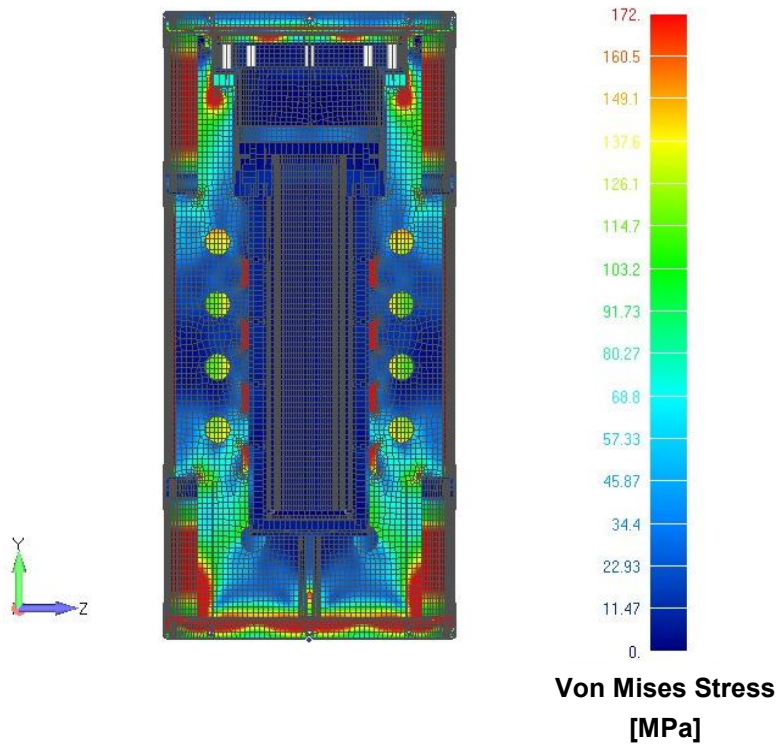
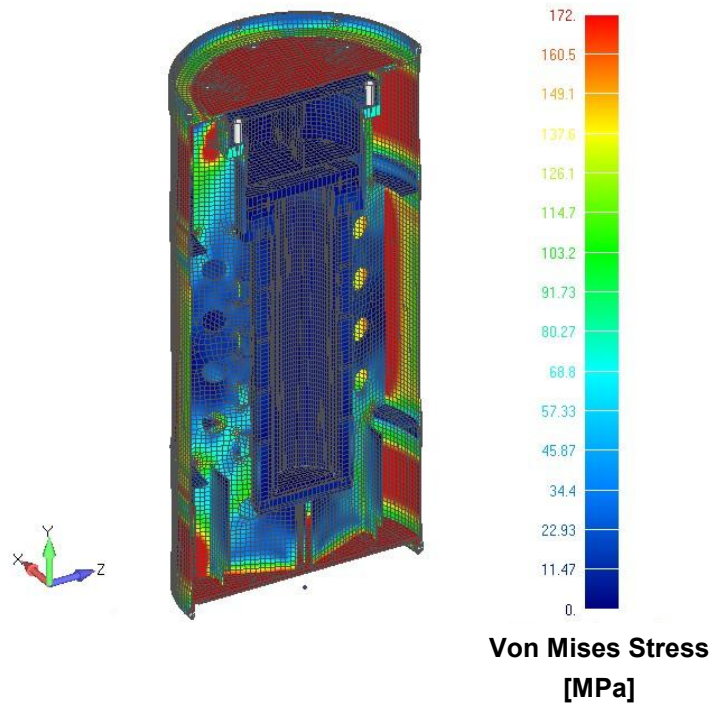

Figure 6: Stresses in the package subject to external pressure



2. The limit stress set in the colors scale is the yield strength of 304L steel of 172 MPa, for the purposes of clearly visualizing the parts involved.

3. The generalized yield state in exterior sheets is evident (in red). Based on these results, the covers and cylindrical sheets where the pressure load is applied will undergo plastic deformation.
4. It is observed that the internal assembly (with the FM) has no compromised stress state.

8.2 Pressure on Internal Assembly Walls

1. Given the prior results where the external confinement is severely compromised, unlike in the internal assembly, it was decided to study a potential load state after deformation of exterior sheets. In the second case, we study the effect of a potential leakage of water to the compartment with kaolite insulation.
2. The components of the internal assembly can be seen on Figure 7:. That assembly is composed of a container of internal containers, a cadmium chamber (with cadmium inside) and a bolted cover with one joint.
3. The internal assembly was simplified by removing the joining elements and making the meshing easier. In we can see the simplified assembly.

Figure 7: Components of the internal assembly

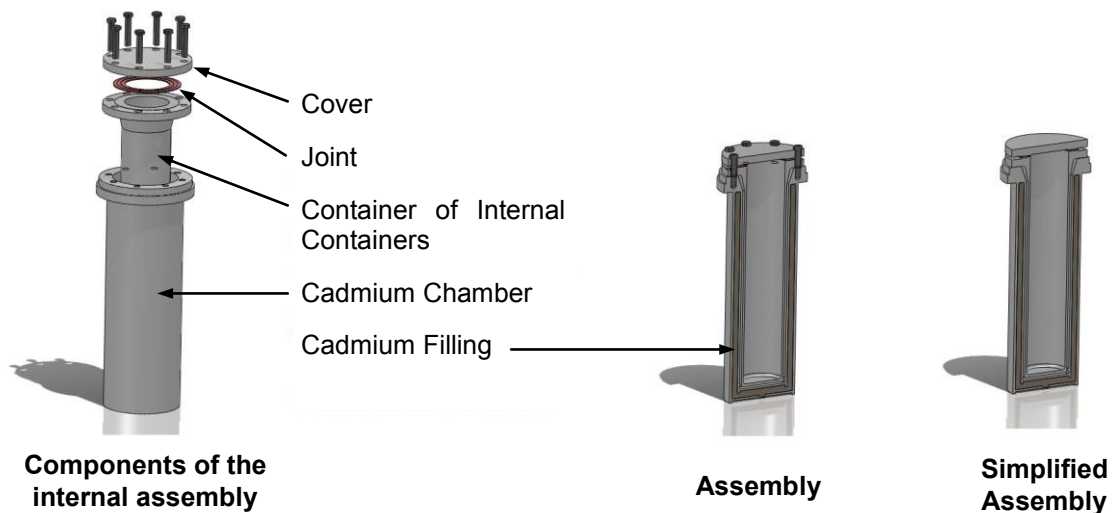

4. If water filters into the insulation compartment, then the pressure is balanced with the exterior pressure (2 MPa), transferring the pressure load to the walls of the internal assembly (the inside remains at the atmospheric pressure).

Figure 8: Status of the load and meshing of the internal assembly

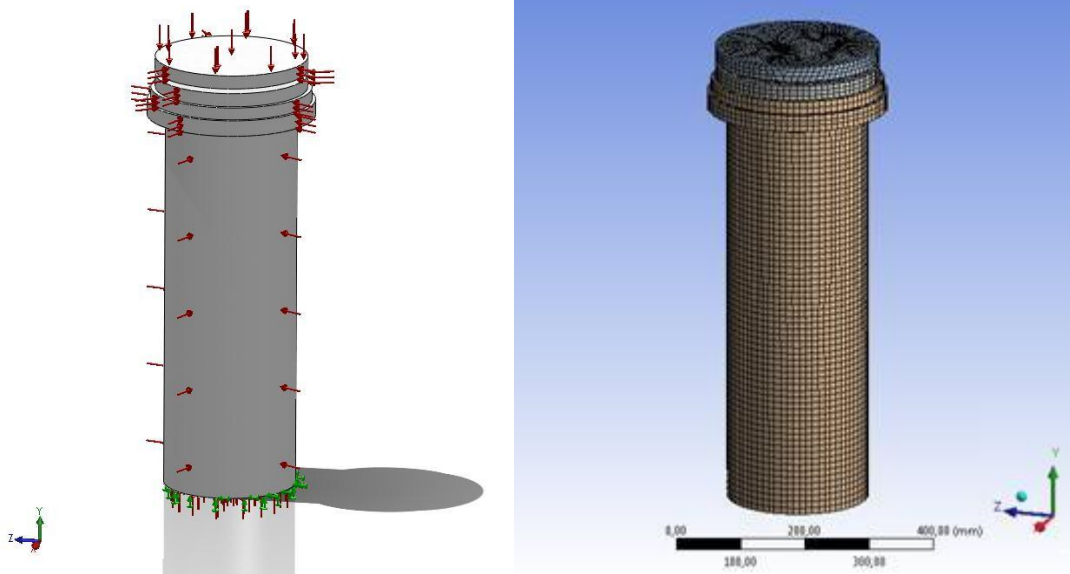

8.2.1 Meshing of the Internal Assembly

1. Hexagonal elements with an average element size of 10 mm were used, generating a mesh with 201633 nodes and 48759 elements (see Figure 8:).

8.2.2 Results of the Internal Assembly

Figure 9: (External) Stresses in the internal assembly subject to external pressure

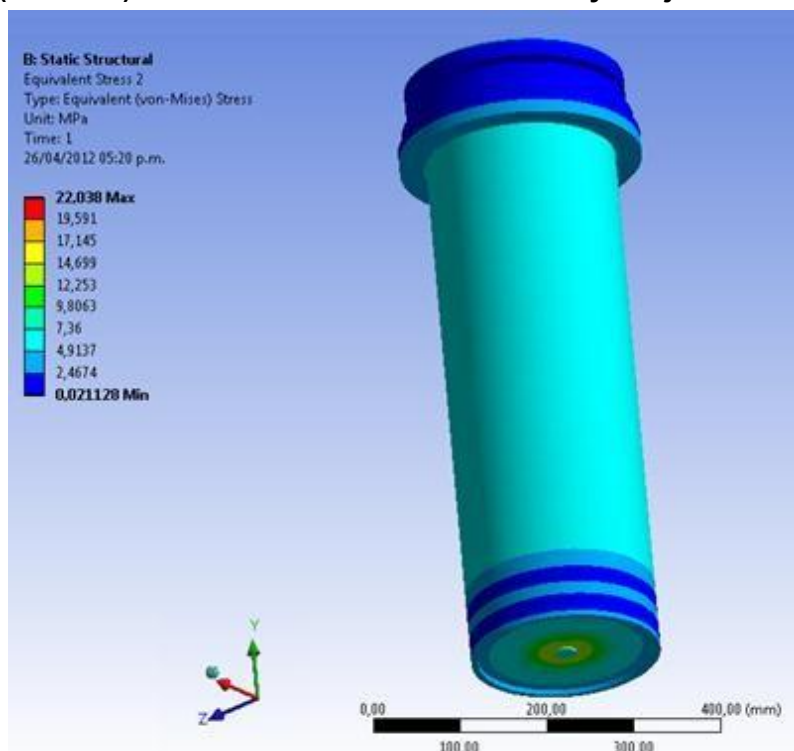
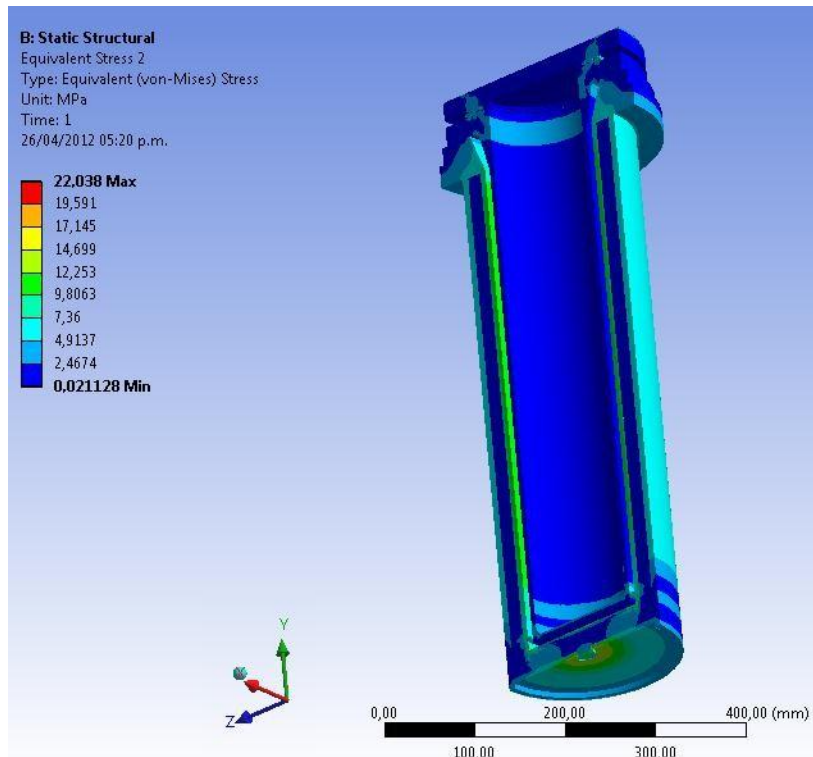
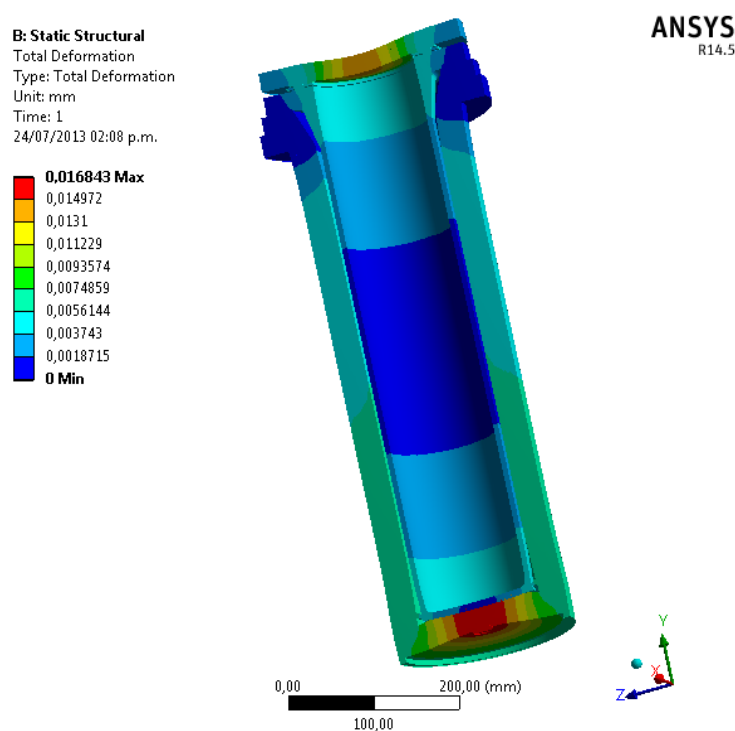

Figure 10: (Internal) Stresses in the internal assembly subject to external pressure



1. The maximum stress is 22 MPa according to the Von Mises criterion, approximately 13% of the yield strength, which means that deformations that may appear are extremely small.

Figure 11: Deformation of the internal assembly (x800) subject to external pressure



2. This external pressure load state favors the hermeticism of the joint between the container of interior containers and the flange, where the pressure causes a closing force minimizing the possibility of leakage of the transported substances.

9 CONCLUSIONS

1. Under the stated conditions, the geometric characteristics and properties of the stated materials, the conclusions are as follows:
 - a. Based on the results obtained, the internal assembly has an admissible stress state when subject to a 2 MPa external pressure.
 - b. The sheets of the external containment get to a yield state with the external pressure load, which causes plastic deformation.
 - c. Although the yield stresses are overcome in the external sheets of the package, the internal container remains in an admissible stress state, even when the kaolite insulation compartment is pressurized.