

LEUPA

Type B(U) Package to Contain Fissile Material

SAFETY REPORT

Made by

IN/AP

June 01, 2015

Page1of31

REVISION SHEET		Document No.: 0908-LE00-3BEIN-023			
		Revision: C			
		Title of Document: Safety Report			
		Ref. No.:			
		Name, date, signature / initial			
Letter Revision	Description of Revision	Prepared	Revised	Approved	
A	Original	EL	NG	JCO	
B	Reference	EL	NG	JCO	

CONTENTS

1	INTRODUCTION.....	6
1.1	DATA.....	6
1.1.1	Petitioner.....	6
1.1.2	Designer.....	6
1.1.3	Manufacturer.....	6
1.1.4	Definitions.....	6
1.2	DESCRIPTION OF PACKAGE.....	7
1.2.1	Safety Barriers.....	8
1.3	REGULATION TO BE COMPLIED WITH.....	8
1.4	PROGRAM OF QUALITY ASSURANCE.....	8
2	DESCRIPTION OF RADIOACTIVE CONTENT.....	8
2.1	DESCRIPTION OF RADIONUCLIDES AND THEIR SPECIFIC ACTIVITIES.....	8
2.2	PHYSICO-CHEMICAL DESCRIPTION OF THE RADIOACTIVE CONTENT.....	9
2.3	SPECIAL DESCRIPTION OF RADIOACTIVE MATERIAL.....	9
2.4	A1-A2 ACTIVITY VALUES.....	9
2.5	GEOMETRICAL DISPOSITION OF THE RADIOACTIVE CONTENT.....	9
2.6	RADIOLOGICAL SAFETY – TRANSPORT INDEX.....	10
2.7	CRITICALITY SAFETY.....	10
2.8	OTHER NON-RADIOLOGICAL DANGEROUS CHARACTERISTICS.....	10
2.9	GENERATION AND DISSIPATION OF HEAT OF RADIOACTIVE CONTENT.....	10
3	DESCRIPTION OF PACKAGING.....	10
3.1	GENERAL DESCRIPTION.....	10
3.2	DESCRIPTION AND PROPERTIES OF PACKAGING MATERIALS.....	10
3.3	MANUFACTURE OF PACKAGING.....	12
3.4	DESCRIPTION, ANALYSIS AND CALCULATION OF THE RADIATION SHIELDING SYSTEM.....	12
3.5	LIFTING, HANDLING AND CLAMPING DEVICES.....	12
3.5.1	Lifting and Handling.....	12
3.5.2	Clamping and Transport.....	13
3.6	MARKING OF PACKAGING.....	14
3.7	PREVENTION MEASURES AGAINST WRONG OPERATIONS.....	14
4	NORMAL CONDITIONS OF TRANSPORT.....	14
4.1	COMPLIANCE WITH GENERAL REQUIREMENTS.....	14
4.2	COMPLIANCE WITH REQUIREMENTS FOR AIR TRANSPORT.....	15
4.3	COMPLIANCE OF REQUIREMENTS RELATED TO TYPE A PACKAGES.....	15
4.4	ANALYSIS OF THERMAL DISSIPATION IN NORMAL TRANSPORT CONDITIONS.....	16
4.5	ANALYSIS, EVALUATION AND DESCRIPTION OF STRESS CALCULATION.....	17
4.6	CHARACTERISTICS OF TESTS.....	17
4.6.1	Tests for Normal Transport Conditions.....	18
4.6.2	Demonstration of Compliance with Acceptance Criteria Tests.....	18

5	CONDITIONS OF ACCIDENT DURING TRANSPORT.....	18
5.1	DEMONSTRATION OF COMPLIANCE WITH REQUIREMENTS RELATED TO TYPE B(U) PACKAGES.....	18
5.1.1	General Requirements related to All Packaging and Packages.....	18
5.1.2	Complementary Requirements related to Packages for Air Transport.....	19
5.1.3	Requirements relative to Type A Package.....	19
5.1.4	Requirements relative to Type B(U) Packages.....	20
5.1.5	Requirements related to Packages containing Fissile Substances.....	21
5.2	DEMONSTRATION OF COMPLIANCE WITH REQUIREMENTS RELATED TO TYPE B(M) PACKAGES.....	21
5.3	CHARACTERISTICS OF TESTS FOR ACCIDENT CONDITIONS DURING TRANSPORT.....	21
5.4	TESTS FOR ACCIDENT CONDITIONS DURING TRANSPORT – MECHANICAL TESTS.....	22
5.4.1	Record and Documentation of Tests.....	22
5.5	ANALYSIS, EVALUATION AND DESCRIPTION OF STRESS CALCULATIONS.....	22
5.5.1	Hypothesis of Heat Calculation.....	22
5.5.2	Hypothesis of Simulation by Finite Elements.....	23
5.5.3	Results.....	23
5.5.4	General Conclusions.....	23
5.6	VERIFICATION OF ACCEPTANCE CRITERIA OF TESTS.....	23
6	USAGE, INSPECTION AND MAINTENANCE OF PACKAGING AND PACKAGES.....	24
6.1	TESTS ESTABLISHED PRIOR TO FIRST DISPATCH OF EACH PACKAGING AND THEIR DESCRIPTION.....	24
6.2	DESCRIPTION OF TESTS PRIOR TO EACH DISPATCH OF PACKAGES.....	24
6.3	CONDITIONS OF TRANSIENT AND BALANCE OF LOADING.....	24
6.4	LEUPA PACKAGE OPERATION MANUAL.....	24
6.5	LEUPA PACKAGE MANUAL OF INSPECTION AND MAINTENANCE.....	24
6.6	INTERVENTION MANUAL IN LEUPA PACKAGE RADIOLOGICAL EMERGENCIES.....	24
7	EVALUATION OF CRICALITY CONTROL.....	24
7.1	ANALYSIS OF CRITICALITY CONTROL.....	24
7.2	EVALUATION OF SUB-CRITICALITY FOR DAMAGED PACKAGES.....	24
7.3	DETERMINATION OF SAFETY INDEX REGARDING NUCLEAR CRITICALITY.....	25
8	REQUIREMENTS FOR RADIOLOGICAL PROTECTION.....	25
8.1	PRINCIPLES OF RADIOLOGICAL PROTECTION.....	25
8.2	DESCRIPTION OF THE PROGRAM OF RADIOLOGICAL PROTECTION.....	25
9	PROGRAM OF QUALITY ASSURANCE.....	25
9.1	MANUAL AND PROGRAM OF QUALITY ASSURANCE.....	25
9.2	INDEPENDENT REVISION.....	25
10	COMPLIANCE WITH STANDARD AR 10.16.1 REV. 2 “TRANSPORT OF RADIOACTIVE MATERIALS”.....	25
11	BIBLIOGRAPHY REFERENCES.....	26
11.1	REFERENCE DOCUMENTS.....	26

11.2	ADDED DOCUMENTS	26
12	ANNEX I.....	27
12.1	PACKAGE DIAGRAM.....	27
12.2	DISASSEMBLY OF PACKAGE.....	28
13	ANNEX II – TEST PLAN	29
14	ANEXO III – TEST PLAN I	30
15	ANNEX IV – TEST PLAN II.....	31

1 INTRODUCTION

1.1 Contact information

1.1.1 Petitioner

Eng. Roberto Barrios
INVAP S.E.
Av. Cmte. Luis Piedrabuena 4950 (ex RN 237)
R8403CPV S.C. de Bariloche
Río Negro – Argentina
Tel.: 54 (294) 4409300
Fax: 54 (294) 4409339
E-Mail: "barrios@invap.com.ar"

1.1.2 Designer

Phys. Juan Carlos Orticelli
INVAP S.E.
Av. Cmte. Luis Piedrabuena 4950 (ex RN 237)
R8403CPV S.C. de Bariloche
Río Negro – Argentina
Tel.: 54 (294) 4409300
Fax: 54 (294) 4409339
E-Mail: "orticell@invap.com.ar"

1.1.3 Manufacturer

José Ausas
INVAP S.E.
Av. Cmte. Luis Piedrabuena 4950 (ex RN 237)
R8403CPV S.C. de Bariloche
Río Negro – Argentina
Tel.: 54 (294) 4409300
Fax: 54 (294) 4409339
E-Mail: "jausas@invap.com.ar"

1.1.4 Definitions

1. LEUPA: Type B(U) package for transport of radioactive material (uranium compounds) in solid state, with type LEU uranium (enrichment lower than 20% in U235 atoms).
2. Inner Container: Container where the radioactive material is housed. It is made of stainless steel and cylindrical. Its cover is threaded to preserve the load.
3. Container of Inner Cans: Cylindrical container where the inner cans are housed. It is completely made of stainless steel and is designed according to ASME Section III, Division 1, Subsection NB.
4. External Cover: External cover of LEUPA. It is fixed to the package by six (6) M12 bolts.
5. Intermediate Cover: Cover that separate the external cover of the container of inner cans. Has in its interior a Kaolite 1600 chamber, which acts as a thermal insulator. It is fixed to the package by six (6) M12 bolts.

6. Inner Cover: Cover that isolated the container of inner cans. Has in its interior a cadmium chamber. It is fixed to the package by eight (8) $\frac{3}{4}$ " bolts. Its design is a standardized blind flange able to resist pressures of 150 Psi.
7. Containment system: Containment barriers between the load and the outside, and it is divided into three parts:
 - a. Container of Inner Cans: This is a container designed according ASME Section III, Division 1, Subsection NB.
 - b. Cadmium Chamber: A chamber of double wall stuffed with cadmium surrounds the container of inner cans. This barrier is also composed of a chamber that is located in the blind flange of the container of cans, surrounding the entire load with cadmium. The cadmium is of high purity, acting as neutron absorber.
 - c. Kaolite Chamber: Surrounding the cadmium chamber, to the outer cover is a space which is filled by a thermal insulator, Kaolite 1600. This material withstands maximum temperatures of 871°C. The intermediate cover also has a kaolite chamber, completely wrapping the load with thermal insulator.
8. Elastomeric Joints: Seal the package with the intermediate and external covers. They are made of nitrile and are 5 mm thick. They protect the load from dirt and humidity.
9. Graphite spiral gasket: Seal located between the blind flange and the container of inner cans. Seal the internal and external load pressures, because it has double support (RWI type). It resists 150 lbs and its standard is ASME B16.20

1.2 Description of Package

1. The type B(U) LEUPA package is one designed for the transport and storage of fissile substances (only U metal of enrichment lower than 20% of U^{235} isotope) solid (metal) or in solid compounds known as U_3O_8 , UO_2 , U_3Si_2 , UN.
2. Fissile substances are placed in steel non airtight vessels called –in the project context– inner cans. Each of them has an inner volume of 1.56 dm³. LEUPA can load as much as four of these cans, which are in turn, housed in the hereby named container. This is designed in accordance with code ASME Section III, Division 1, Sub-section NB, with a usable inner volume of around 8.25 dm³. Design pressure and temperature taken into account are 700 kPamanometric and 70 °C, respectively. The container is formed by the main body and standardized flanges, both made of stainless steel. The flange is joined to the main body by means of eight (8) UNC $\frac{3}{4}$ " screws. The joint between both is sealed by a graphite spiral gasket allowing a working temperature limit of 450 °C. For its handling, the flange has an ergonomic designed folding handle.
3. Rubber add-ons fill in the gap between inner cans and the container so as to reducedynamic effects in case of normal or accidental transportation.
4. Joined to the container there is a cylindrical component with double stainless steel wall. The space between both walls (around 17 mm) is filled in with casted high purity cadmium. The cadmium mass used is about 58 kg. The flanged cover of the container also has a double wall within which cadmium is casted, and in this way the fissile substance load is almost completely surrounded by neutron absorbent material.
5. This set forms a compact and undeformable central cell.
6. Outside the central cell above described, there are eight (8) stainless steel structural welded plates radially placed, which link said cell with the external wall of the packaging. Besides, this package has four angle profile rings, one at each end of package and the other two at around one third (1/3) and two thirds (2/3) of the height of the packaging respectively, for reinforcement. Each ring is welded to the radial plates, and these, in turn, to the central cell making a built-in unity. The external wall of the packaging is a stainless steel cylinder plate. The packaging has circular covers welded at the ends, which make, together with the external wall and the central cell, a volume where thermal insulation is

poured by gravity casting technique; the central cell is thus surrounded by around 150 mm of thermal insulator.

7. The packaging has a removable intermediate cover which is a welded structure made with a stainless steel cylinder plate and circular covers, which in the same way as stated above, define a volume that allows filling with thermal insulator by gravity casting technique, with a thickness of around 150 mm.
8. The removable intermediate cover is joined to the rest of the package by means of six (6) M12 screws with an elastomeric gasket between both parts.
9. Outside the removable intermediate cover there is another cover made of a stainless steel circular plate, also fixed to the rest of the package by six (6) M12 screws. Between both parts there is also a 5 mm thick elastomeric gasket to avoid the entering of dirt and humidity.
10. Both the external cover and the removable intermediate one have ergonomic designed folding handles.
11. All package elements are meant for impact protection; it constitutes a set which absorbs mechanical energy by deformation without losing its thermal protection capacity.
12. The thermal insulator to be used is under the brand name Kaolite 1600, a cementitious composite on vermiculite powder to be mixed with water, and which can be used at 1600 °F (871 °C); it can be applied either by gravity filter or by pressure.
13. Its mechanical properties depend on drying conditions.
14. The external cover and the rest of the packaging have pieces for the tamper-proof shielding of the package by means of high resistance brass seals, which are furthermore carved with permanent characters.
15. The packaging has four lifting points with standardized shackles with a lifting capacity of 0.5 ton each; they are appropriately linked to the upper ring of the packaging.

1.2.1 Safety Barriers

1. The barriers that allow for a safe transport of the material, from the external part of the package to its inner part, are the following:
 - a. External and Intermediate Covers.
 - b. Inner Container.
 - c. Inner Cans.

1.3 Regulation to be Complied with

1. The regulation to be complied with is the one stated in Standard AR 10.16.1 "Transport of Radioactive Materials" Rev. 2, in all requirements applicable to said Standard.

1.4 Program of Quality Assurance

1. The design, the manufacture of test prototypes, and the planning of tests were accomplished according with the company's quality assurance system, which complies with ISO 9001:2008 Standards and ISO 14001:2004 Environment.

2 DESCRIPTION OF RADIOACTIVE CONTENT

2.1 Description of Radionuclides and their Specific Activities

1. Radionuclides to be transported contain:
 - a. U^{235} with a content not over 20% (19.75 ± 0.25 %) of the total content of U to be transported (50 kg).

- b. U^{238} with a content not less than 80% (80.00 ± 0.25 %) of the total content of U to be transported (50 kg).
2. The specific activities of radionuclides are not taken into account in accordance with Standard AR 10.16.1 "Transport of Radioactive Materials" Rev. 2, Section IV, Chart 2. "Basic Values of Radionuclides", said Standard does not set limits for the transport of material in such activity.

2.2 Physico-chemical Description of the Radioactive Content

1. The fissile substance to be transported is mainly formed by:

Table 1: Fissile Substances

Substance	Density g/cm ³
U (in blasts)	19.0
UO ₂	10.96
U ₃ Si ₂	12.20
UN	14.32
U _x Al	< 8.07
U ₃ O ₈	8.30

2. All material to be transported must be in solid state, at normal pressure and temperature conditions.
3. The U to be transported is LEU type, enrichment lower than 20% in U^{235} atoms.

2.3 Special Description of Radioactive Material

1. Non-applicable.

2.4 A1-A2 Activity Values

1. Specific activities of radionuclides are not taken into account as stated in Standard AR 10.16.1 "Transport de Radioactive Materials" Rev. 2, and Section IV, Chart 2. "Basic Values of Radionuclides" of the mentioned Standard does not establish limits for the transport of material of such activity.

2.5 Geometrical Disposition of the Radioactive Content

1. Radioactive content is placed as follows:
 - a. The material is put in heat-sealed plastic bags (matter limit 12.5 kg).
 - b. Each bag is introduced in a cylindrical stainless steel can with a cap screw, which is called inner can.
 - c. The surplus volume inside the inner can, in case there is any, shall be filled with expandable resin.
 - d. Each can is placed vertically, one on top of the other forming a column inside the container of inner cans.
 - e. In the case of transport of less than four inner cans, it is completed to four with empty inner cans.

2.6 Radiological Safety – Transport Index

1. A conservative dose rate calculation was done with the program MicroShield, and further cross-checked with MCNP. Under normal conditions of transport, the estimated dose rate at 1 meter from the external surface of the LEUPA package, is 0.0009 mSv/h (see Doc. 0908-LE01-3BEIN-028 - Dose Rate Calculations).
2. According with paragraph 521 of the Standard AR 10.16.1 Rev. 2, the TI would be of $TI=0.09$
3. Said index must be assessed with the radiometry to be carried out before transport so as to add it on the label.

2.7 Criticality Safety

1. The Criticality Safety Index was evaluated in Document 0908-LE01-3BEIN-024, LEUPA – CRITICALITY ANALYSIS, complying with requirements of Standard AR 10.16.1– Rev. 2, the result being of a 0.69 value, which is way down the accepted limits (Chart 12, section V of Standard AR 10.16.1 – Rev. 2).

2.8 Other Non-Radiological Dangerous Characteristics

1. Since the material is in solid state at ambient pressure and temperature, it is considered that, except for accidental intake, it does not have non-radiological dangerous characteristics.
2. The non-radiological dangerous characteristic is the toxicity of the U composites, it is thus necessary to adopt all appropriate measures to avoid intake during handling, such as the wearing of masks, gloves, etc.

2.9 Generation and Dissipation of Heat of Radioactive Content

1. The generation of heat due to the content of fissile substances (U, UO_2 , U_3Si_2 , UN, U_3O_8) is negligible.

3 DESCRIPTION OF PACKAGING

3.1 General Description

1. See Doc. 0908-LE01-3AEIN-004 – PACKAGE GENERAL ASSEMBLY – to attached plan and Annex I Package Diagram.
2. The package is cylindrical and has the following components from the inside to the outside:
 - a. Four inner cans which house the material to be transported.
 - b. One container that contains the inner cans.
 - c. One cadmium tube-shaped plate used as neutron absorber.
 - d. One Kaolite 1600 blanket that forms the thermal insulator of the package.
 - e. Several elastomeric and metal gaskets that contribute to water-tightness of cans.
 - f. The external packaging that provides resistance and protection to all other components.

3.2 Description and Properties of Packaging Materials

1. See Doc. 0908-LE01-3BEIN-013 – MANUFACTURE SPECIFICATION according to attached document.
2. There follows details of dimension:

Table 2: Subset Dimensions

Subset	Material	Diameter [mm]	Height [mm]	Mass [kg]
Inner Can (4)	Stainless steel	123	157	(1.7) 6.8
Container of Inner Cans	Stainless steel	141.3	686	30
Neutron Absorbent	Cadmium (purity 99.5%)	219.1	676	58
Thermal Insulator	Kaolite 1600	–	–	75
Packaging	Stainless Steel	532	1155	260
Several Gasket	Nitrile	–	–	0.2
Total Mass of Package	–	–	–	430

- All the above mentioned materials are of daily use in the nuclear industry, something which guarantees its usage at the established temperatures (-40 °C and +70 °C), in the expected low radiation levels; and ensures the absence of gas generation by chemical reactions, or radiolysis or radiolytic dissociation.

3.3 Manufacture of Packaging

- The manufacture was in accordance with procedures and specifications stated in Doc. 0908-LE01-3BEIN-013 – SPECIFICATION OF MANUFACTURE under attached document.

3.4 Description, Analysis and Calculation of the Radiation Shielding System

- A conservative dose rate calculation was done with the program MicroShield, and further cross-checked with MCNP. Under normal conditions of transport, the estimated dose rate in contact with the external surface of the LEUPA package, is 0.012 mSv/h (see Doc. 0908-LE00-3DEIN-028 Dose Rate Calculation).
- Due to the expected low limit dose it is not considered necessary to have an additional shielding system.

3.5 Lifting, Handling and Clamping Devices

3.5.1 Lifting and Handling

- The lifting and movement must be carried out by means of a four section sling joined by a master link, and a DIN 5691 hook at the end.
- Hooks must have a minimum working capacity of 1000 kg each.
- The sling may be a rope A8 x 130 DIN 655 (2900 kg), otherwise the rope must not be less than 6 mm diameter.
- The x angle may be of 60°, otherwise said angle must be lower than 90° (see Picture 1:).
- The shackles to be used must be type DIN 82101, or more resistant.
- The slings must be manufactured with standardized components (thimbles, cord grips, hooks, shackles, etc.)
- The loading system (crane, lifting gear, etc.) to be used must have a minimum capacity of 1000 kg.

8. During handling, package must be moved at the least possible distance from the ground.
9. To calculate the lifting device of LEUPA container, see Doc. No 0908-LE01-3BEIN-012 – VERIFICATION OF LIFTING POINTS.
10. To calculate the Clamping Device for the transport of LEUPA package, see Doc. No 0908-LE01-3BEIN-025 – CLAMPING ANALYSIS FOR TRANSPORT.

Picture 1: Diagram of lifting and handling of package



3.5.2 Clamping and Transport

1. The LEUPA transport must be carried out placing the package vertically, with covers upwards on the means of transportation chosen; and it must be clamped from the four (4) bracings to the ground.
2. To transport LEUPA package, recommendations are to fix package as shown in Picture 2:.
3. The angle must be at least 45°.
4. The shackles must be DIN 82101 type, or more resistant ones.
5. The anchoring turnbuckles must be steel cables as to DIN 3060, external diameter 6 mm minimum (7 x 19 – steel core).
6. The slings must be manufactured with standardized components (thimbles, cord grips, hooks, shackles, etc.)
7. Any other clamping method to be adopted must be revised and approved by manager of dispatch before transport.
8. To calculate the lifting device for LEUPA package, see Doc. No 0908-LE01-3BEIN-012 – VERIFICATION OF LIFTING POINTS.
9. To calculate the Clamping Device for the transport of LEUPA Package, see Doc. No 0908-LE01-3BEIN-025 – CLAMPING FOR TRANSPORT.

Picture 2: Clamping of LEUPA package for transport

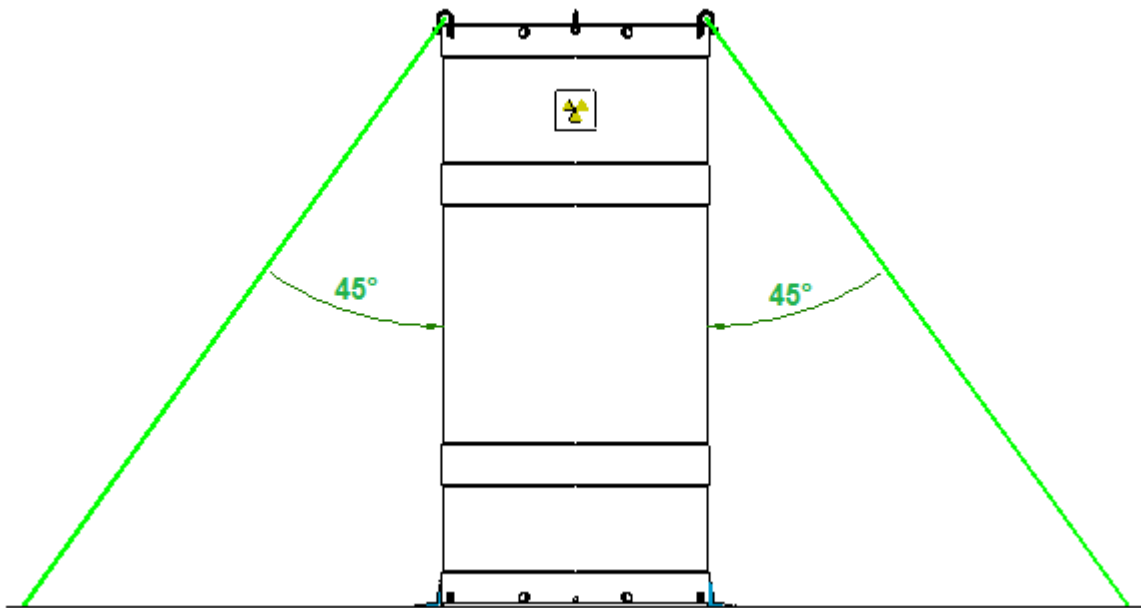

3.6 Marking of Packaging

1. The marking of packaging was made following what is stated in Standard AR.10.16.1 – Rev. 2, “Transport of Radioactive Material” with the following plates:
 - a. Warning Plate (see Draw. 0908-LE01-3AEIN-017 “PACKAGING – MAIN BODY WARNING PLATE”) as in attached document.
 - b. Name Plate (see Draw. 0908-LE01-3AEIN-018 “PACKAGING – MAIN BODY NAME PLATE”) as in attached document.
 - c. Design and Manufacture Plate (see Draw. 0908-LE01-3AEIN-019 “PACKAGING-MAIN BODY DESIGN AND MANUFACTURE PLATE”) as in attached document.

3.7 Prevention Measures against Wrong Operations

1. See Doc. 0908-LE00-3BEIN-017 – OPERATION MANUAL as in attached document.
2. Verify that all loading operations of fissile substance have been made by an experienced work team, and under the supervision of an experienced professional or technician.
3. Verify the perfect sealing of each inner can, and after that the placement of the safety belt.
4. Verify the sealing of each cover (inner, intermediate and external) and their corresponding security seals.
5. Verify that the LEUPA package has the loading and dispatch forms.
6. All operations of handling and lifting must be controlled; they must be carried out according with points 3.5.1 and 3.5.2.
7. Any other operation method must be approved by the dispatch manager.

4 NORMAL CONDITIONS OF TRANSPORT

4.1 Compliance with General Requirements

1. The LEUPA package meets all requirements stated in Standard AR 10.16.1 “Transport of Radioactive Materials – Rev. 2” regarding packaging and type B(U) packages. This is

shown in the corresponding documentation, Attached Documents and drawings (11.2 of this document), taking into account the following paragraphs of the Standard:

- a. Paragraph 606: The package has been designed so as to be easily transported and adequately fixed during transport (see Doc. 0908-LE01-3AEIN-004 attached).
- b. Paragraph 607: The hook device is designed with enough safety margin so as not to fail during lifting of package (see Doc. 0908-LE01-3AEIN-004 attached).
- c. Paragraph 608: The hook devices to lift the package are designed to bear the total mass of the package (see Docs. 0908-LE01-3AEIN-004 and 0908-LE01-3BEIN-012 attached).
- d. Paragraph 609: The external surfaces of the package do not have protruding parts, therefore they may be easily cleaned (see Docs. 0908-LE01-3AEIN-004 and 0908-LE01-3AEIN-010 attached).
- e. Paragraph 610: The upper surface of the package complies with the requirement of avoiding water storage (see Doc. 0908-LE01-3AEIN-004 / 0908-LE01-3AEIN-010 attached).
- f. Paragraph 611: Additional elements to package are not stated, except the clamping material (slings, ropes, etc.).
- g. Paragraph 612: The package is designed to bear acceleration, vibration or vibrating resonance effects that may occur in normal conditions of transport, especially, bolts, nuts and clamping devices (see Docs. 0908-LE01-3AEIN-004 and 0908-LE01-3AEIN-010 attached).
- h. Paragraph 613: The materials used in the design of the package are of normal use in nuclear industry (see Docs. 0908-LE01-3AEIN-010 and 0908-LE01-3BEIN-013 attached).
- i. Paragraph 614: In the design of the package there are no valves.
- j. Paragraph 615: Ambient temperatures and pressures that may appear in routine transport conditions have been taken into account in the design of the package (see Docs. 0908-LE01-3AEIN-004 and 0908-LE01-3AEIN-005 / 0908-LE01-3BEIN-011 attached).
- k. Paragraph 616: Materials to be transported do not have any other dangerous properties, except for an accidental intake.

4.2 Compliance with Requirements for Air Transport

1. Paragraph 617: Temperature of the accesible surfaces of the package for air transport, do not get to the 50 °C limit, the inner heat generation is negligible.
2. Paragraph 618: The package is designed to bear temperatures between -40 °C and +55 °C (see Docs. 0908-LE01-3BEIN-013 and 0908-LE01-3AEIN-010 / 0908-LE01-3BEIN-011 attached).
3. Paragraph 619: The package is designed to bear, without leakage of their inner cans, an inner pressure that may produce a pressure difference not less than the normal work pressure limit, plus 95 kPa.

4.3 Compliance of Requirements related to Type A Packages

1. Paragraph 427: Sends to Paragraph 428 and 429 of the Standard.
2. Paragraph 428: Complies with requirements since its activity A2 is under the one established for packages A according to Chart 2 of the Standard.
3. Paragraph 429: The package is not designed to transport radionuclides mixtures, except $U^{235}+U^{238}$, therefore the same considerations are to be applied.

4. Paragraph 633: The design of the package meets the requirements mentioned in 5.1.1, 1 to 11, which correspond to Paragraphs 606 to 616 of the Standard AR 10.16.1 Rev 2. "Transport of Radioactive Materials".
5. Paragraph 634: The smallest overall external total dimension of the package is over 0.1 m (see Doc. 0908-LE01-3AEIN-004 attached).
6. Paragraph 635: The package will have in its outer part a seal, as a sign which guarantees the package will not be opened, except by competent authorities (see Doc. 0908-LE01-3AEIN-004 attached).
7. Paragraph 636: The package is designed to bear the acting forces in normal and accidental transport conditions (see Docs. 0908-LE01-3AEIN-004 / 0908-LE01-3AEIN-005, 0908-LE01-3BEIN-001 and 0908-LE01-3BEIN-011 attached).
8. Paragraph 637: The package is designed so that all its components can bear temperatures between -40°C and +70°C without any deterioration in its capacity. It must be taken into account that liquid substances are not transported under said temperature conditions (see Docs. 0908-LE01-3AEIN-005 and 0908-LE01-3BEIN-011 attached).
9. Paragraph 638: Design and manufacturing techniques of the prototype meet national standards AR 10.16.1 Rev. 2 and international ones ASME III – DIV I Sub Sec. NB (see Docs. 0908-LE01-3BEIN-001 and 0908-LE01-3BEIN-011 attached).
10. Paragraph 639: The design of the package has a containment system tightly sealed which prevents from non-intentional opening (see Docs. 0908-LE01-3AEIN-005 and 0908-LE01-3BEIN-010 attached).
11. Paragraph 640: The design of the package does not consider the transport of radioactive materials in special form.
12. Paragraph 641: The package containment system can be sealed independently from other parts of packaging (see Docs. 0908-LE01-3AEIN-004, 0908-LE01-3AEIN-005 and 0908-LE01-3BEIN-010 attached).
13. Paragraph 642: The package design does not consider the transport of liquid substances that may separate radiolytically, nor substances that generate gases by chemical reaction or radiolysis.
14. Paragraph 643: The containment system is designed to retain its content even when ambient pressure drops to 60 kPa (see Docs. 0908-LE01-3BEIN-011 and 0908-LE01-3AEIN-005 attached).
15. Paragraph 644: Package design does not include valves.
16. Paragraph 645: Package design does not include shielding against radiations due to their low level.
17. Paragraph 646: Package design contemplates bearing the specified tests in Paragraphs 719 to 724.
18. Paragraph 647: The package is not designed to transport liquid substances.
19. Paragraph 648: Idem point 18, Paragraph 647.
20. Paragraph 649: The package is not designed to transport gaseous substances.
21. All requirements shall be justified by means of the tests described in Specifications 0908-LE02-3BEIN-002.

4.4 Analysis of Thermal Dissipation in Normal Transport Conditions

1. Due to the nature and the quantity of transported material, the generation of inner heat is negligible.

4.5 Analysis, Evaluation and Description of Stress Calculation

1. The structural calculation of the container of inner cans has been carried out, it is the stainless steel container that houses the inner cans with the fissile substances to be transported (see Tech. Specifications 0908-LE01-3BEIN-011).

Table 3: Design data

Data	Value
Design Inner Pressure	700 kPa
Hydraulic Test Pressure	875 kPa
Design Temperature	70 °C
Mass of Content	50 kg

2. The piece is manufactured in type 304L stainless steel, with the respective quality assurance certificate.
3. Results: The minimum required thickness by the ASME III NB design code is 0.4 mm and the one available in the market is 6.55 mm.
4. In the case of the flat bottom, the accepted (92.4 MPa) Code stress relation and the one obtained by calculation(32 MPa) is 2.88.

4.6 Characteristics of Tests

1. In Doc. 0908-LE02-3BEIN-002 "LEUPA – SPECIFICATIONS OF TESTS FOR APPROVAL AS TYPE B(U) PACKAGE TO CONTAIN FISSILE SUBSTANCES" there is a detailed description of tests, geometric scaling, tests methods and acceptance criteria. The tests to be carried out are the ones required by Standard AR 10.16.1 Rev. 2 "Transport of Radioactive Materials" for the transport of fissile substances in normal and accidental conditions.
2. Necessary tests will be made for:
 - a. "Tests to demonstrate the bearing capacity of normal transport conditions".
 - b. The test method to be used is established in Doc. 0908-LE02-3BEIN-002 "LEUPA – SPECIFICATION OF TESTS FOR THE APPROVAL AS TYPE B(U) PACKAGE TO CONTAIN FISSILE SUBSTANCES".
 - c. The prototype to be used in tests is scale 1:1 in relation to the original package and it is made with the same materials as the original one.
 - d. In the prototype package the fissile substance is simulated by means of 2 mm lead pellets.
 - e. Lead pellets are used because it is a high density material available in the market, and the difference with uranium is compensated by adding a larger quantity, until the specified mass is reached.
 - f. It is a conservative system from the structural viewpoint, since cans are fuller than with U.
 - g. Taking a bulk density of 80% of theoretical, with U, around 42% of the available volume is completed, versus an approx. 70% loaded with Pb.
 - h. The pellets are put into cylindrical polyethylene heat sealed bags of around 200 micrometers thick. The polyethylene bags size is slightly less than the inner dimensions of the inner cans, in order to allow their placement inside the cans. Each

bag has a 12.5 kg +/- 0.5 kg mass, comparable to the fissile substance to be simulated.

- i. The water spraying and drop tests are carried out at the CNEA site in Pilcaniyeu (Río Negro province).
- j. The piling and infiltration tests are performed at the CNEA site in Pilcaniyeu (Río Negro province).
- k. The subsequent thermal test is carried out at the CNEA site in Pilcaniyeu (Río Negro province).
- l. The sequence of tests is described in annexes II, III and IV of this document.

4.6.1 Tests for Normal Transport Conditions

1. See point 7 of the Specifications No 0908-LE02-3BEIN-002 "LEUPA – SPECIFICATIONS OF TEST FOR THE APPROVAL AS TYPE B(U) PACKAGE TO CONTAIN FISSILE SUBSTANCES".

4.6.2 Demonstration of Compliance with Acceptance Criteria Tests

1. The acceptance criteria are described after each TEST in Specifications No 0908-LE02-3BEIN-002 "LEUPA – SPECIFICATION OF TESTS FOR APPROVAL AS TYPE B(U) PACKAGE TO CONTAIN FISSILE SUBSTANCES".

5 CONDITIONS OF ACCIDENT DURING TRANSPORT

5.1 Demonstration of Compliance with Requirements related to Type B(U) Packages

1. The LEUPA meets all the requirements established in Standard AR 10.16.1 Rev. 2 "Transport of Radioactive Materials" as related to packaging and type B(U) packages.

5.1.1 General Requirements related to All Packaging and Packages

1. Paragraph 606: The package has been designed to be easily transported, and to be appropriately clamped during transport (see Doc. 0908-LE01-3AEIN-004 attached).
2. Paragraph 607: The clamping device is designed with enough safety margin so that it will not fail during lifting of package (see Doc. 0908-LE01-3AEIN-004 attached).
3. Paragraph 608: Clamping devices to lift package are designed to bear the total mass of package (see Docs. 0908-LE01-3AEIN-004 and 0908-LE01-3BEIN-012 attached).
4. Paragraph 609: The outside surfaces of the package have no protrusions to enable an easy cleansing (see Docs. 0908-LE01-3AEIN-004 and 0908-LE01-3AEIN-010 attached).
5. Paragraph 610: The upper surface of the package does fully meet the requirement of avoiding water storage (see Doc. 0908-LE01-3AEIN-004 / 0908-LE01-3AEIN-010 attached).
6. Paragraph 611: The adding of any additional element to the package is not considered, except for clamping material (slings, ropes, etc.).
7. Paragraph 612: The package is designed to bear acceleration, vibration or vibrating resonance that may be produced in routine transport conditions, specially bolts, nuts and clamping devices (see Docs. 0908-LE01-3AEIN-004 and 0908-LE01-3AEIN-010 attached).
8. Paragraph 613: Materials used in the design of the package are of normal use in the nuclear industry (see Docs. 0908-LE01-3AEIN-010 and 0908-LE01-3BEIN-013 attached).
9. Paragraph 614: There are no valves considered in the package design.

10. Paragraph 615: Ambient temperatures and pressures that may appear in routine transport conditions have been taken into account in the design of the package (see Docs. 0908-LE01-3AEIN-004 and 0908-LE01-3AEIN-005 / 0908-LE01-3BEIN-011 attached).
11. Paragraph 616: Transport materials do not have other dangerous properties except for the accidental intake.

5.1.2 Complementary Requirements related to Packages for Air Transport

1. Paragraph 617: Temperature of the accessible surfaces of the package for air transport, not reach to the 50 °C limit, because the inner heat generation is insignificant.
2. Paragraph 618: The package is designed to bear temperatures between -40 °C and +55 °C (see Docs. 0908-LE01-3BEIN-013 and 0908-LE01-3AEIN-010 / 0908-LE01-3BEIN-011 attached).
3. Paragraph 619: The package is designed to bear, without leakage of their inner cans, an inner pressure that may produce a pressure difference not less than the normal work pressure limit plus 95 kPa(see Docs. 0908-LE01-3BEIN-011 and 0908-LE01-3AEIN-005 attached).

5.1.3 Requirements relative to Type A Package

1. Paragraph 633: The design of the package meets the requirements mentioned in 5.1.1, 1 to 11, which correspond to Paragraphs 606 to 616 of the Standard AR 10.16.1 Rev 2. "Transport of Radioactive Materials".
2. Paragraph 634: The smallest overall external total dimension of the package is over 0.1 m (see Doc. 0908-LE01-3AEIN-004 attached).
3. Paragraph 635: The package will have in its outer part a seal as a sign which guarantees the package will not be opened, except by competent authorities (see Doc. 0908-LE01-3AEIN-004 attached).
4. Paragraph 636: The package is designed to bear the acting forces in normal and accidental transport conditions (see Docs. 0908-LE01-3AEIN-004 / 0908-LE01-3AEIN-005, 0908-LE01-3BEIN-001 and 0908-LE01-3BEIN-011 attached).
5. Paragraph 637: The package is designed so that all its components can bear temperatures between -40°C and +70°C without any deterioration in its capacity. It must be taken into account that liquid substances are not transported under said temperature conditions (see Docs. 0908-LE01-3AEIN-005 and 0908-LE01-3BEIN-011 attached).
6. Paragraph 638: Design and manufacturing techniques of the prototype meet national Standards AR 10.16.1 Rev. 2 and international ones ASME III – DIV I Sub Sec. NB (see Docs. 0908-LE01-3BEIN-001 and 0908-LE01-3BEIN-011 attached).
7. Paragraph 639: The design of the package has a containment system tightly sealed which prevents from non-intentional opening (see Docs. 0908-LE01-3AEIN-005 and 0908-LE01-3BEIN-010 attached).
8. Paragraph 640: The design of the package does not consider the transport of radioactive materials in special form.
9. Paragraph 641: The package containment system can be sealed independently from other parts of packaging (see Docs. 0908-LE01-3AEIN-004, 0908-LE01-3AEIN-005 and 0908-LE01-3BEIN-010 attached).
10. Paragraph 642: The package design does not consider the transport of liquid substances that may separate radiolitically, nor substances that generate gases by chemical reaction or radiolysis.
11. Paragraph 643: The containment system is designed to retain its content even when ambient pressure falls to 60 kPa (see Docs. 0908-LE01-3BEIN-011 and 0908-LE01-3AEIN-005 attached).

12. Paragraph 644: Package design does not include valves.
13. Paragraph 645: Package design does not include shielding against radiations due to their low level.
14. Paragraph 646: Package design contemplates bearing the specified tests in Paragraphs 719 to 724.
15. Paragraph 647: The package is not designed to transport liquid substances.
16. Paragraph 648: Idem point 18, Paragraph 647.
17. Paragraph 649: The package is not designed to transport gaseous substances.
18. All requirements shall be justified by means of the described tests in Specifications 0908-LE02-3BEIN-002.

5.1.4 Requirements relative to Type B(U) Packages

1. Paragraph 650: The design of the package meets the requirements specified in Paragraphs 606 to 616 of the Standard (see point 5.1.1 Paragraphs 1 to 11 of this document); Paragraphs 617 to 619 of the Standard (see point 5.1.2 Paragraphs 1 to 3 of this document); Paragraphs 634 to 647 of the Standard (see point 1 Paragraphs 1 to 15 of this document), specially section a) of Paragraph 646, to avoid the loss and dispersal of the radioactive content.
2. Paragraph 651: Due to the substance to be transported, the quantity of heat to be generated is negligible, because of what is mentioned in a) b) and c) they are given no special attention.
3. Paragraph 652: The design of the package takes into account that due to the type of material used, the temperature on its accesiblesurfaces, in the absence of solar radiation, does not exceed 50 °C.
4. Paragraph 653: Due to the negligible heat generation of the substances to be transported it is not possible to reach 85 °C on any surface of the package, in absence of solar radiation, therefore, the use of protective screens or barriers is not considered.
5. Paragraph 654: The ambient temperature will be assumed to be 38 °C, the one considered in Doc. 0908-LE00-3DEIN-018 attached.
6. Paragraph 655: The values of solar radiation of table13 of the Standard in Doc. 0908-LE00-3DEIN-018 attached, shall be taken into account.
7. Paragraph 656: The heat protection used in the design of the package, Kaolite 1600, is considered to bear the demands of the tests specified in Paragraphs 719 to 724 and in sections a), b) and c) of Paragraph 727 of the Standard (see Doc. 0908-LE00-2BEIN-015 attached).
8. Paragraph 657: Since the radioactive substance to be transported has no limit for A2 (table2 of the Standard), the conservative design criteria was chosen, according to which the loss of substance because of damage in the inner can which contains the radioactive substance will not be allowed in any test to be made on the package (see Doc. 0908-LE01-3BEIN-024 attached).
9. Paragraph 658: Non-applicable because of requested values in the paragraph.
10. Paragraph 659: See point 5.1.4 Paragraph 8.
11. Paragraph 660: The design of the package does not have a pressure relief system in the containment system.
12. Paragraph 661: See point 5.1.4 Paragraph 8.
13. Paragraph 662: The design considers the normal work pressure limit not above 700 kPa (see Doc. 0908-LE01-3BEIN-011 attached).
14. Paragraph 663: Non-applicable.

15. Paragraph 664: The package is designed for an interval of ambient temperature between -40 °C and +38°C (see Docs. 0908-LE01-3BEIN-013 and 0908-LE01-3AEIN-010 / 0908-LE01-3BEIN-011 attached).

5.1.5 Requirements related to Packages containing Fissile Substances

1. Paragraph 671: Criticality calculations under the worst theoretical conditions show results in accordance with Paragraphs 680 a) and b) of the Standard (see Doc. 0908-LE01-3BEIN-024 attached).
2. Paragraph 672: Non-applicable due to the absence of H, H₂O, Pu, Be and Uranyl Nitrate in the substances to be transported.
3. Paragraph 673: Non-applicable because the chemical and physical form of the content is known (see point 2.2 of this document).
4. Paragraph 674: Non-applicable due to the fissile substance to be transported.
5. Paragraph 675: See Doc. 0908-LE02-3BEIN-002 attached.
6. Paragraph 676: See point 5.1.4 Paragraph 15 of this document.
7. Paragraph 677: Provided for in the criticality calculations of the package (see Doc. 0908-LE01-3BEIN-024 attached).
8. Paragraph 677a: Non-applicable in this design because it has been proved that in the worst condition (the entry of water), the set keeps sub-critical.
9. Paragraph 678: Provided for in the criticality calculations of the package (see Doc. 0908-LE01-3BEIN-024 attached).
10. Paragraph 679: Provided for in the criticality calculations of the package (see Doc. 0908-LE01-3BEIN-024 attached).
11. Paragraph 680: Paragraph a) see point 5.1.5 Paragraph 1 of this document.
12. Paragraph 681: See point 5.1.5 Paragraph 1 of this document.
13. Paragraph 682: See point 5.1.5 Paragraph 1 of this document.
14. Paragraph 683: The calculated CSI is 0.69 (see Doc. 0908-LE01-3BEIN-024 attached).

5.2 Demonstration of Compliance with Requirements related to Type B(M) Packages

1. Non-applicable.

5.3 Characteristics of Tests for Accident Conditions during Transport

1. In Doc. 0908-LE02-3BEIN-002 "LEUPA – SPECIFICATIONS OF TESTS FOR APPROVAL AS TYPE B(U) PACKAGE FOR THE CONTAINMENT OF FISSILE SUBSTANCES" tests, geometrical scaling, test methods and acceptance criteria are described.
2. The necessary tests to demonstrate the capacity of bearing accident conditions during transport were carried out.
3. As it was done in normal transport conditions tests, the prototype to be used in tests is scale 1:1 in relation to the original package and it is manufactured with the same materials as the original package.
4. In the prototype package the fissile substance is simulated by means of 2 mm diameter lead pellets. The pellets are put into cylindrical polyethylene heat sealed bags of around 200 micrometers thick. The polyethylene bags size is slightly less than the inner dimensions of the inner cans, in order to allow their placement inside the cans. Each bag has a 12.5 kg +/- 0.5 kg mass, comparable to the fissile substance to be simulated.

5. The water immersion and drop tests shall be carried out at the CNEA site in Pilcaniyeu (Province of Río Negro).
6. The subsequent thermal test is carried out at the CNEA site in Pilcaniyeu (Río Negro province).

5.4 Tests for Accident Conditions during Transport – Mechanical Tests

1. See point 7 of Specification No 0908-LE02-3BEIN-002 “LEUPA – SPECIFICATION OF TESTS FOR THE APPROVAL AS TYPE B(U) PACKAGE TO CONTAIN FISSILE SUBSTANCES”.

5.4.1 Record and Documentation of Tests

1. Each test, whether for normal or accidental transport, shall be recorded in the following way:
 - a. A written record of each test shall be drawn, stating date, time, and manager of test, personnel involved and public figures.
 - b. The mechanical tests shall be filmed with at least two cameras placed orthogonally to the plane, so that high resolution images can be obtained.
 - c. In drop tests the state previous to test shall be photographed from at least two orthogonal points of view. Photographs shall take all elements included in the test. In cases where separators are used to verify the drop head, photographs shall be taken at verifying time.
 - d. Damages in specimen shall be photographed in detail. Photographs shall be duly coded to relate them in a one to one way to each test.
 - e. Specimen damages shall be described in written, with references to the positions of LEUPA manufacturing drawings, and to the generatrix marked in the specimen. The damage report shall include deformed or torn parts; and references to photograph codes above stated.
 - f. In case of screwed joints without visible damage, the necessary torque for its opening after the test must be stated.
 - g. After penetration tests, the state of indenters shall be photographed. In case of evident damage, it must be included in report, with a written description of said damage.

5.5 Analysis, Evaluation and Description of Stress Calculations

1. See Doc. 0908-LE01-3BEIN-011 “LEUPA – CALCULATION REPORT”.
2. See Doc 0908-LE00-2BEIN-015 “LEUPA – HEAT ANALYSIS”.
3. Conclusions:
 - a. The design verifies the requirements of acceptable tensions of the Code of design and the available thickness. The available thickness in the pressure boundary verifies acceptable stresses for the material used, and the selected flanges meet the necessary rate of appliance in the inner can. The design verifies requirements.
 - b. The maximum stresses are around 32 MPa and the maximum displacement is three hundredth of a millimeter.

5.5.1 Hypothesis of Heat Calculation

1. For an approximate calculation only the solid composites Kaolite 1600 are considered.
2. Thermal bridges or metal coatings are not considered.
3. The cadmium contained in the vertical area of the container is treated as cylinder, the content at the bottom of the package and the cover are treated as semi-infinite solid.

4. For the external temperature of the package, 900 °C is adopted. This is a conservative value compared to the one established by the Standard AR 10.16.1 Rev. 2 "Transport of Radioactive Materials".
5. The external heat transfer coefficient is considered to be very large, therefore, to the effects of calculation, it is considered infinite.
6. The thermal properties of Kaolite 1600 are evaluated in such a way so as to make a conservative calculation.

5.5.2 Hypothesis of Simulation by Finite Elements

1. For the calculation of finite elements only heat conduction is taken into account.
2. In a conservative way, the elastomer and graphite gasket are considered as steel.
3. The air gaps are considered as solids with the same thermal properties as air.
4. All thermal bridges of the prototype are considered.
5. In a conservative way, two structural reinforcements (thermal bridges for simulation) are considered instead of one in the cover filled with Kaolite 1600.
6. The external temperature of 900 °C of the package is adopted. This value is a conservative one as regards the one stated by the Standard AR.10.16.1 Rev. 2 "Transport of Radioactive Materials".
7. It is considered that the cover of the external container and the double bottom have no thermal isolation, therefore, they are not taken into account in the simulation; and the external surface of the cover filled with Kaolite 1600 together with the inner bottom of the container have a surface temperature of 900 °C, as the walls of the external container.
8. The thermal properties of the Kaolite 1600 are evaluated so as to make a conservative calculation:
 - a. Lower density.
 - b. Thermal conductivity is variable with temperature.
 - c. Heat capacity considered as the average of the heat capacity of its components, evaluated at 100 °C.

5.5.3 Results

1. After 1 hour the maximum temperatures are:
 - a. Cadmium of container: T = 80 °C.
 - b. Cadmium of container cover: T = 68.5 °C.
 - c. Stainless-graphite spiral gasket: T = 72.4 °C.
 - d. Elastomer gasket: T = 820.5 °C.

5.5.4 General Conclusions

1. No hotspots are observed with temperatures higher than fission temperature (320.9 °C) in the cadmium inside the container and the cover.
2. No limit temperatures are found in the graphite spiral gasket.
3. The elastomer gaskets would char.

5.6 Verification of Acceptance Criteria of Tests

1. The analysis of the results in several tests show they must have met, without exception, all requirements set on each test.

6 USAGE, INSPECTION AND MAINTENANCE OF PACKAGING AND PACKAGES

6.1 Tests established prior to First Dispatch of each Packaging and their Description

1. See Doc. 0908-LE00-3BEIN-026 "LEUPA MANUAL OF INSPECTION AND MAINTENANCE".

6.2 Description of Tests prior to each Dispatch of Packages

1. See Doc. 0908-LE00-3BEIN-026 "LEUPA MANUAL OF INSPECTION AND MAINTENANCE".

6.3 Conditions of Transient and Balance of Loading

1. Due the material to be transported does not generate neither heat nor gases that may increase the pressure and/or temperature of the container, this point is no-applicable.

6.4 LEUPA Package Operation Manual

1. See Doc. 0908-LE00-3BEIN-017 "LEUPA OPERATION MANUAL" as in document attached.

6.5 LEUPA Package Manual of Inspection and Maintenance

1. See Doc. 0908-LE00-3DEIN-026 "LEUPA PACKAGE OF INSPECTION AND MAINTENANCE".

6.6 Intervention Manual in LEUPA Package Radiological Emergencies

1. See Doc. 0908-LE00-3DEIN-018 "LEUPA TRANSPORT MANUAL" as in document attached.

7 EVALUATION OF CRICALITY CONTROL

7.1 Analysis of Criticality Control

1. In Doc. 0908-LE01-3BEIN-024 "LEUPA –CRITICALITY ANALYSIS" as in document attached, the evaluation of sub-criticality for intact isolated package was made, and also for ordered packages in the pertinent dispatch, taking into account variation of criticality with penetration or leakage of water, inclusion of neutron absorbent, changes in geometry among packages and in the fissile content, immersion in water or snow, temperature changes, the configuration and moderation which will produce maximum multiplication of neutrons, and the greatest reflection.
2. The conclusion is that both the isolated package as well as the ordered set of packages are subcritical in all suggested settings.

7.2 Evaluation of Sub-criticality for Damaged Packages

1. In document 0908-LE01-3BEIN-024 "LEUPA – ANALYSIS OF CRITICALITY", as in document attached, there has been an evaluation of sub-criticality for the isolated damaged packages and for ordered sets of packages in the pertinent dispatch, considering the variation of criticality with penetration or water leakage, damage/defects in fabrication of the neutron absorbents, changes in geometry among packages and in the fissile content, immersion in water or snow, temperature changes, the configuration and

moderation which will produce maximum multiplication of neutrons, and the greatest reflection.

2. The conclusion is that both the isolated package as well as the ordered set of packages are subcritical in all suggested settings.

7.3 Determination of Criticality Safety Index

1. The safety index regarding criticality was evaluated in Doc. 0908-LE01-3BEIN-024 "LEUPA –CRITICALITYANALYSIS" as in document attached, in compliance with requirements of standard AR 10.16.1 Rev. 2, the result being a value of 0.69, which is far below the accepted limits (Charter 12, Section V of standard AR 10.16.1).

8 REQUIREMENTS FOR RADIOLOGICAL PROTECTION

8.1 Principles of Radiological Protection

1. Due to the nature and quantity of material to be transported, the given dose is considered negligible.

8.2 Description of the Program of Radiological Protection

1. See Specification 0908-LE00-3BEIN-025 attached.

9 PROGRAM OF QUALITY ASSURANCE

9.1 Manual and Program of Quality Assurance

1. See Doc. 0908-LE00-EDEIN-019 "PROGRAM FOR MANAGEMENT OF QUALITY FOR THE LEUPA PROJECT" as in document attached.

9.2 Independent Revision

1. An independent verification has been made in accordance with Paragraph 9.2 of guideline TMR-GUICON-R4. Concerning the criticality analysis, see Doc. 0908-LE02-3BEIN-007 attached.

10 COMPLIANCE WITH STANDARD AR 10.16.1 REV. 2 "TRANSPORT OF RADIOACTIVE MATERIALS"

1. It is considered that requirements established in Standard AR 10.16.1 Rev. 2 "Transport of Radioactive Materials", for this type of packages are duly met.
2. The package may be easily transported due to its weight, volume and lifting systems (Draw. 0908-LE01-3AEIN-004 "PACKAGE GENERAL ASSEMBLY" as in document attached).
3. External surfaces have no protruding parts.
4. During immersion tests, it will be stated that covers are waterproof.
5. They have the conditions to bear accelerations during transport due to their clamping systems and bracing (nuts, screws, bolts, etc., with dimensions for this purpose).
6. Materials used are compatible with each other, and with radioactive materials to be transported.
7. In the design the requirements for air transport have also been considered.

11 BIBLIOGRAPHY REFERENCES

11.1 Reference Documents

1. ARN. *Transport of Radioactive Materials*. Standard AR 10.16.1. Rev. 2. Argentine Republic: ARN, 2011.
2. TMR-GUICON-R4 "*Basic Content of Safety Reports*".

11.2 Added Documents

1. Doc. 0908-LE02-3BEIN-002 "LEUPA – SPECIFICATION OF TESTS FOR APPROVAL AS TYPE B(U) PACKAGE FOR THE TRANSPORT OF RADIOACTIVE MATERIALS".
2. Doc. 0908-LE01-2BEIN-011 "LEUPA – CALCULATION REPORT".
3. Doc. 0908-LE01-3BEIN-012 "LEUPA – VERIFYING LIFTING POINTS"
4. Doc. 0908-LE01-3BEIN-013 "LEUPA – MANUFACTURING SPECIFICATION".
5. Doc. 0908-LE00-2BEIN-015 "LEUPA – THERMAL ANALYSIS".
6. Doc. 0908-LE00-3BEIN-017 "LEUPA – OPERATION MANUAL".
7. Doc. 0908-LE00-3BEIN-018 "LEUPA – TRANSPORT MANUAL".
8. Doc. 0908-LE00-EDEIN-019 "PROGRAM FOR THE MANAGEMENT OF QUALITY ASSURANCE OF LEUPA PROJECT".
9. Doc. 0908-LE01-3BEIN-024 "LEUPA – CRITICALITY ANALYSIS".
10. Plan 0908-LE01-3AEIN-004 "PACKAGE GENERAL ASSEMBLY".
11. Plan 0908-LE02-3AEIN-005 "PLATES FOR TEST" (as in Paragraph 727 c)).
12. Plan 0908-LE01-3AEIN-010 "PACKAGING OF MAIN BODY".
13. Plan 0908-LE01-3AEIN-017 "PACKAGING OF MAIN BODY – WARNING PLATE"
14. Plan 0908-LE01-3AEIN-018 "PACKAGING OF MAIN BODY – NAME PLATE".
15. Plan 0908-LE01-3AEIN-019 "PACKAGING OF MAIN BODY – DESIGN AND MANUFACTURING PLATE".
16. Plan 0908-LE02-3AEIN-012 "QUICK RELEASE HOOK FOR DROP TEST".
17. Doc. 0908-LE02-3BEIN-003 "LEUPA – ANALYSIS OF DROP POSITION WITH GREATER DAMAGE".
18. Doc. 0908-LE00-3BEIN-025 "PROGRAM OF RADIOLOGICAL PROTECTION".
19. 0908-LE01-3BEIN-027 "CALCULATION LINE FOR LEUPA SUB-CRITICALITY ANALYSIS"
20. 0908-LE01-3BEIN-028-A "DOSE RATE CALCULATIONS"
21. 0908-LE02-3BEIN-007-A "INDEPENDENT REVIEW OF DOC 0908-LE01-3BEIN-024-B CRITICALITY ANALYSIS".

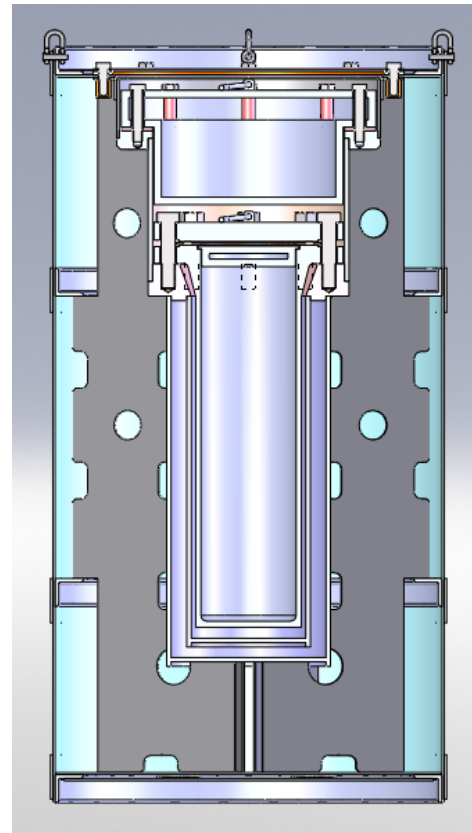
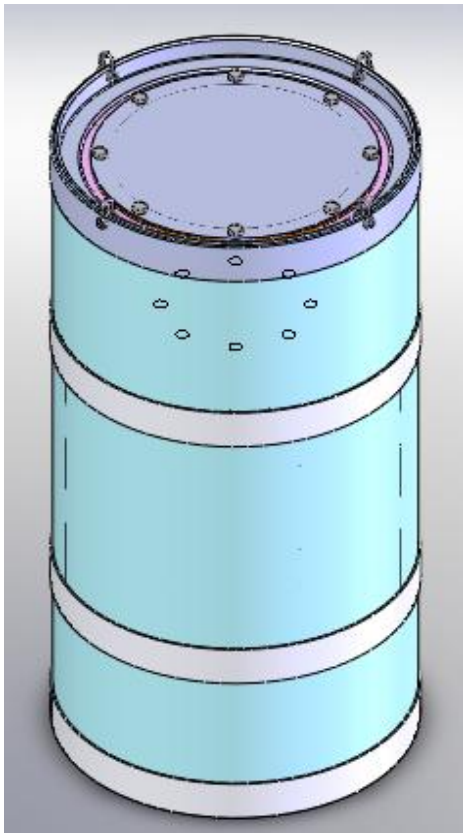
12 ANNEX I**12.1 Package Diagram**

12.2 Disassembly of Package

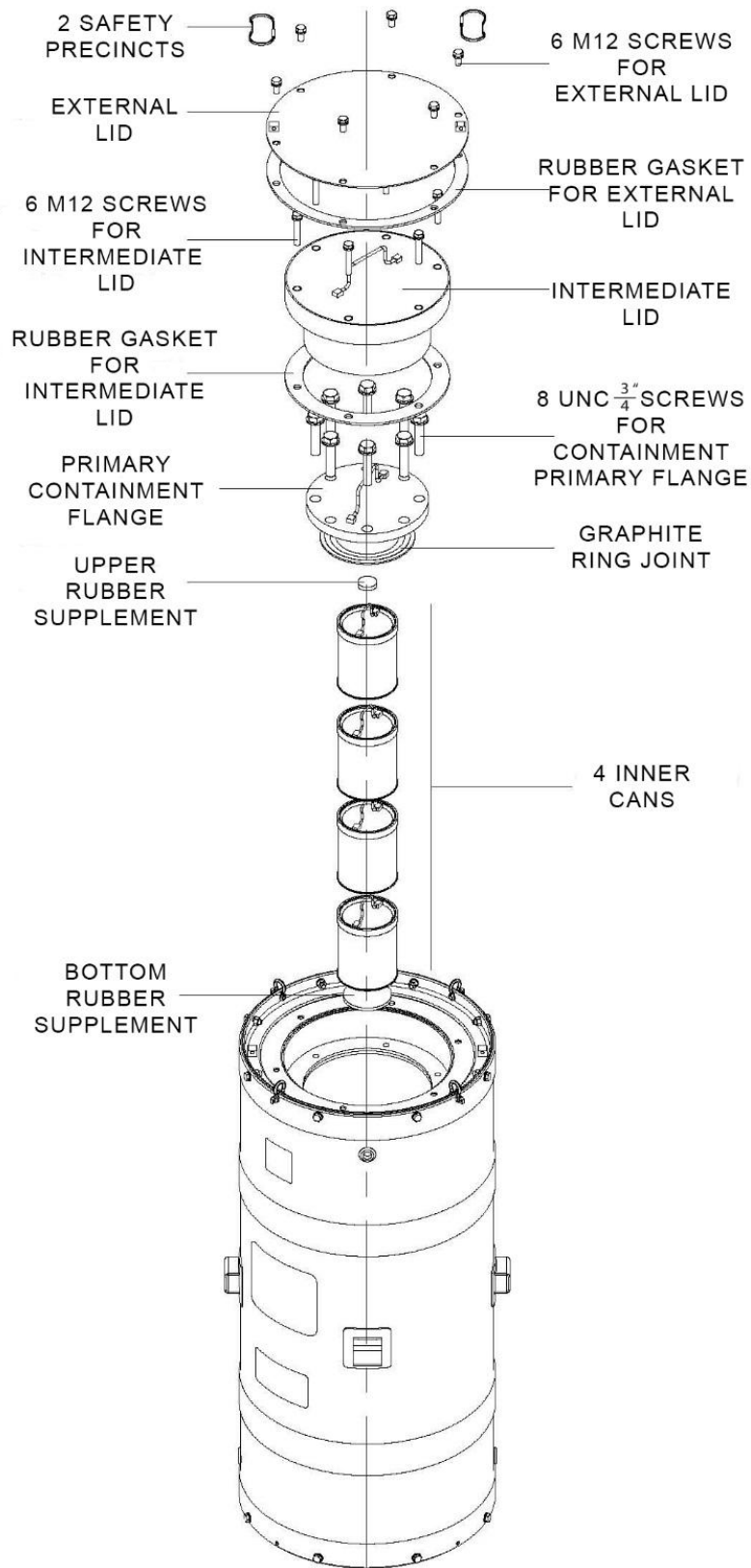

13 ANNEX II – TEST PLAN

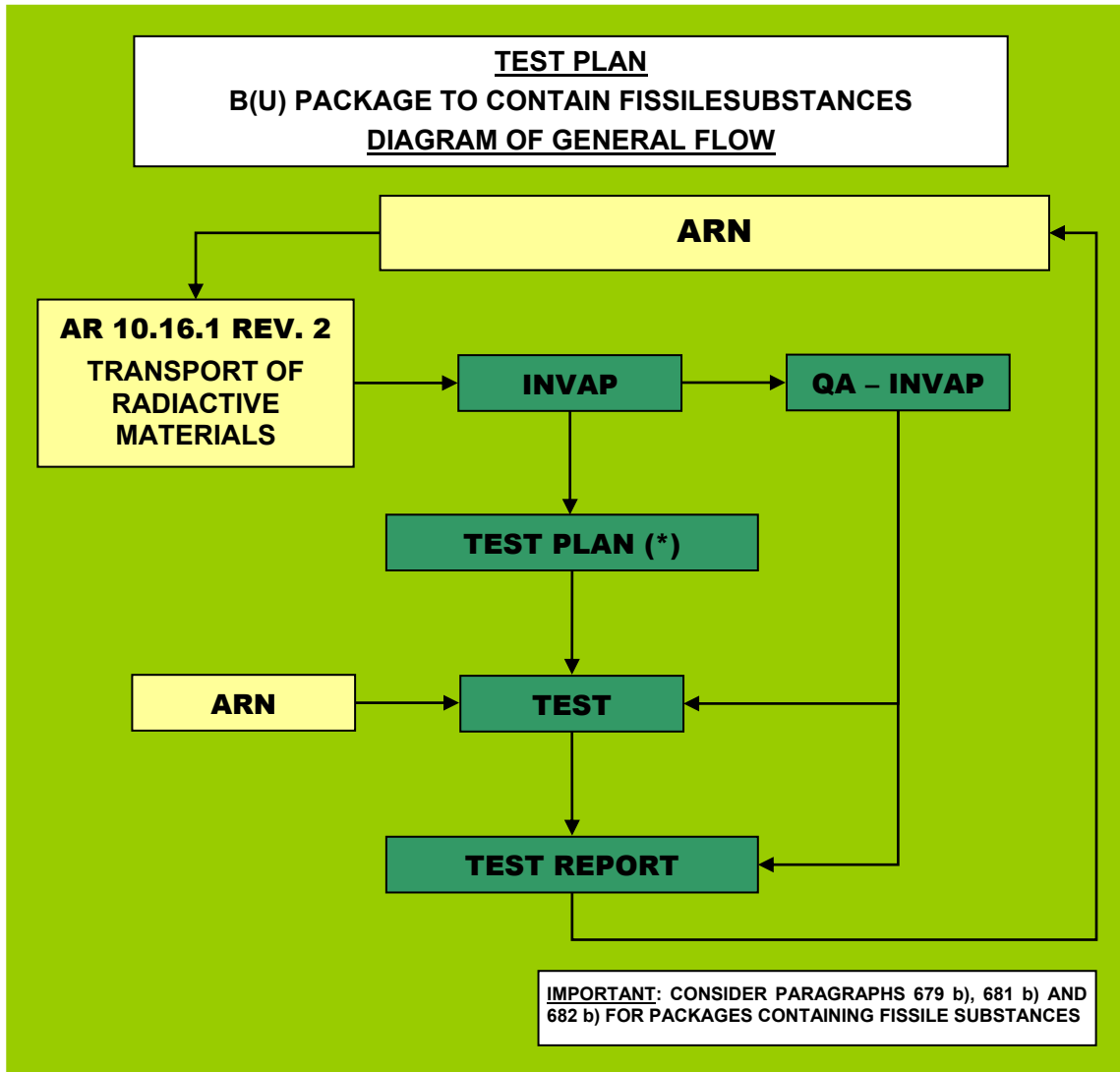

14 ANEXO III – TEST PLAN I

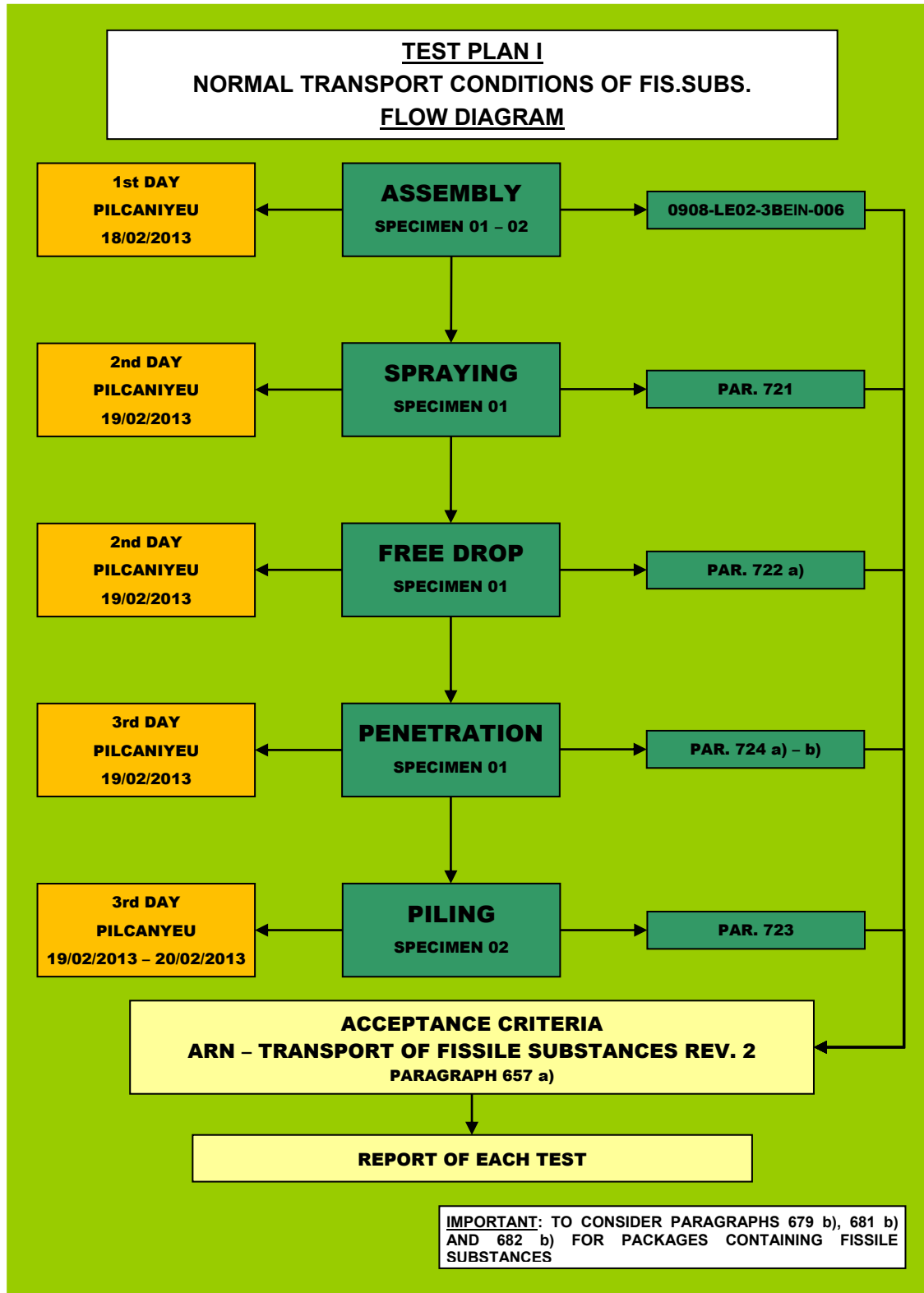

15 ANNEX IV – TEST PLAN II

