

Fuel Failure Mechanisms

1. There are two basic types of fuel failure accidents that are relevant to the RINSC reactor:
 - A. Mechanistic failures, in which the cladding is breached as a result of mechanical damage, and
 - B. Non-Mechanistic failures, in which the cladding is breached as a result of overheating.
2. Of the two types of failure, the mechanistic failure is considered to be far more likely than the non-mechanistic failure at the RINSC facility. The most realistic scenario that could lead to a mechanistic fuel failure is fuel handling, which occurs on an annual basis during fuel inspections. Non-mechanistic failure is considered to be extremely unlikely. The transient analyses for the RINSC core show that over power excursions in which the over power protections operate as designed, lead to a peak fuel temperature of 88.8 C¹. The loss of coolant accident analysis shows that for the maximum credible accident scenario, the peak cladding temperature for the most limiting fuel plate is still below the blister temperature of the cladding, given the predicted time that it would take for the pool level to drain down to the top of the fuel².
3. For a major non-mechanistic power plant fuel failure accident, there are five phases of failure³:
 - A. Coolant Activity Release

For power plants, initially there is usually a coolant system failure in which radionuclides in the coolant leak out of the system. If the cooling system is unable to keep the cladding sufficiently cool, cladding failure will occur.
 - B. Gap Activity Release

Inside the fuel, a gap exists between the fuel and the cladding. Radionuclides accumulate in this gap. When the cladding is breached, these nuclides are free to escape. During this phase, a few percent of the more volatile nuclides, such as Cs and I escape, while the bulk of the fission products are retained in the fuel.

C. Early In-Vessel Release

During this phase, the fuel begins to degrade and melt until it slumps to the bottom of the reactor vessel. During this phase, all of the noble gases, and a significant fraction of the volatile nuclides such as iodine and cesium are released.

D. Ex-Vessel Release

For a power plant, if the bottom of the reactor vessel fails, the molten core debris will interact with the concrete structural material beneath the vessel. This will cause some of the less volatile nuclides to be release directly into the containment.

E. Late In-Vessel Release

At the same time that the ex-vessel release phase is occurring, and for a longer duration than that phase, late in-vessel release occurs. During this phase, volatile nuclides that had deposited in the cooling system during the in-vessel phase, are release into containment.

4. Of the fuel failure phases that occur in nuclear power plants, only the gap and the onset of in-vessel release phases are relevant to the RINSC reactor. The RINSC reactor does not have an appreciable amount of activity buildup in the coolant due to activation, so coolant activity release is not a major concern. Gap activity release is relevant for any fuel cladding failure, regardless of whether it is due to mechanistic or non-mechanistic events, so this release consequence must be considered. It is plausible, though unlikely that the onset of early in-vessel release could occur, and that the integrity of the cladding could begin to be compromised during a fuel failure at the RINSC facility. However, the transient and loss of coolant accident analyses show that it is not plausible for this phase to progress to the point in which the core material slumps to the bottom of the pool. Ex vessel release, and late in vessel release are not considered to be credible for the RINSC reactor.

Radionuclides Released from Fuel to Coolant

1. The available regulatory guidance regarding the quantity of radioactive material that gets into the coolant from the damaged fuel is geared toward nuclear power plants, rather than low power research reactors. The guidance is divided into information that pertains to low pressure boiling water reactors (BWR), versus information related to high pressure, pressurized reactors (PWR). Of the two types of reactors, the RINSC reactor is more similar to a BWR than a PWR. Consequently, the guidance for BWRs was used.

- The radionuclides that are expected to be released as a result of gap and early in-vessel fuel failure have been grouped on the basis of chemical similarity⁴. There are seven groups that are expected to get into the coolant⁵:

Group	Elements
Noble Gases	Xe, Kr
Halogens	I, Br
Alkali Metals	Cs, Rb
Tellurium Group	Te, Sb, Se, Ba, Sr
Noble Metals	Ru, Rh, Pd, Mo, Tc, Co
Lanthanides	La, Zr, Nd, Eu, Nb, Pm, Pr, Sm, Y, Cm, Am
Cerium Group	Ce, Pu, Np

Release Fraction from Fuel to Coolant

- Regulatory Guide 1.183 indicates that during the gap and early in-vessel release phases of fuel failure, the release fractions from the fuel to the confinement air are⁶:

Group	Gap Release Phase	Early In-Vessel Release Phase	Total
Noble Gases	0.05	0.95	1.0
Halogens	0.05	0.25	0.3
Alkali Metals	0.05	0.20	0.25
Tellurium Metals	0.00	0.05	0.05
Ba, Sr	0.00	0.02	0.02
Noble Metals	0.00	0.0025	0.0025
Lanthanides	0.00	0.0002	0.0002
Cerium Group	0.00	0.0005	0.0005

- This assumes an accident scenario in which there is not an appreciable amount of coolant through which these isotopes would have to pass in order to reach the confinement air.
- For the RINSC fuel failure scenario, it is anticipated that during these release phases there will still be an appreciable amount of coolant in the pool, so these release fractions can be considered to be the fractions that are released into the coolant.

Release Fraction from Coolant to Confinement Air

- As mentioned earlier, the credible fuel failure accident scenarios do not involve an instantaneous coolant loss, so the fuel failure scenario described in the guidance that best fits the facility is the fuel handling accident scenario.

2. All of the fission products that are released from the fuel are in particulate form except for⁷:
 - A. Elemental Iodine (I₂)
 - B. Organic Iodide
 - C. Noble Gases

3. Particulates:
 - A. The particulates are assumed to be retained by the water in the pool¹¹. Consequently, only the iodines and noble gases must be considered in the analysis.

4. Iodine:
 - A. If there were not an appreciable amount of coolant acting as a barrier between the fuel and the confinement air:
 1. The chemical form of the iodine that is released from the coolant into the confinement air would be⁷:
 - A. Cesium Iodide (CsI) 95%
 - B. Elemental Iodine (I₂)4.85%
 - C. Organic Iodide 0.15%
 2. The cesium iodide is expected to completely dissociate in the pool water, after which, the iodine is expected to re-evolve as elemental iodine (I₂) due to the low pH of the water relatively instantaneously⁸.
 - B. However, RINSC Technical Specifications require that the height of the pool water over the top of the fuel meat be at least 23 feet 7 inches for both natural convection operation, and forced convection operation⁹.
 - C. If the depth of the water above the damaged fuel is 23 feet or greater, then 99.5% of the total iodine in the coolant remains in there, and the composition of the iodine that reaches the confinement air is¹⁰:
 1. Elemental Iodine (I₂) 57%
 2. Organic Iodide 43%

5. Noble Gases:
 - A. The retention of the noble gases in the pool water is assumed to be negligible¹¹.

6. Therefore, the isotopes that are relevant due to the fact that a significant fraction of them will be transported to the confinement air are the iodines and noble gases.
 - A. Given the fact that at the RINSC reactor the water depth is at least 23 feet over the fuel meat, the fraction of the halogens that are released into the pool water that will reach the confinement air is 0.5% of the content in the coolant.
 - B. The noble gases will be unaffected by the coolant, so it is anticipated that 100% of the noble gases that are released into the pool water will reach the confinement air.

Overall Release Fraction from Fuel to Confinement Air

1. Of the activity available to be released from the fuel, the overall release fraction to the confinement air is:

$$(\text{Release Fraction from Fuel to Coolant})(\text{Release Fraction from Coolant to Air})$$

2. This means that the release fractions from the fuel to the confinement air are:

Group	Gap Release Phase	Early In-Vessel Release Phase	Total
Noble Gases	0.05	0.95	1.0
Halogens	$(0.05)(0.005) = 0.00025$	$(0.25)(0.005) = 0.00125$	0.0015

Release Rates¹²

1. The guidance for BWRs indicates that the durations of each of these release phases are:

Phase	Duration
Gap Release	0.5 hours
Early In-Vessel Release	1.5 hours

2. The early in-vessel release phase begins after the gap release has ended.
3. The guidance indicates that during each release phase, it is allowable to use a linear model of the activity release over the duration of the phase.

Accident Assumptions

1. The highest power fuel plate is damaged under at least 23 feet of water.
2. The reactor has been operated long enough for the fission product inventory to reach saturation.

Peak Power Fuel Plate Fission Fragment Inventory

1. Highest Power Fuel Plate

- A. The memo regarding the Steady-State Thermal-Hydraulic Analysis for Forced-Convective Flow in the Rhode Island Nuclear Science Center (RINSC) Reactor, indicates that power of the highest power plate during full power reactor operation at 2 MW is 9.653 kW.¹³

2. Fission Rate

- A. The energy associated with each fission event that occurs in the reactor is 200 MeV per fission.

- B. Converting from MeV to MW – Seconds:

$$\left[\frac{200 \text{ MeV}}{\text{fission}} \right] \left[\frac{1.6 \times 10^{-13} \text{ Joule}}{\text{MeV}} \right] \left[\frac{\text{Watt} - \text{Second}}{\text{Joule}} \right] \left[\frac{\text{MW}}{10^6 \text{ Watt}} \right]$$

$$= 3.2 \times 10^{-17} \text{ MW} - \text{second per fission}$$

- C. Therefore the fission rate at 1 MW power is:

$$\frac{1}{\left[\frac{3.2 \times 10^{-17} \text{ MW} - \text{Second}}{\text{fission}} \right]} = 3.1 \times 10^{16} \text{ fission per MW} - \text{Second}$$

- D. In order to generate 9.653 kW of power in the highest power fuel plate, the fission rate in that plate must be:

$$\left[\frac{3.1 \times 10^{16} \text{ fission}}{\text{MW} - \text{second}} \right] \left[\frac{\text{MW}}{1000 \text{ kW}} \right] \left[\frac{9.653 \text{ kW}}{1} \right]$$

$$= 2.992 \times 10^{14} \text{ fission / second} \sim 3 \times 10^{14} \text{ fission / second}$$

2. Fission Nuclide Production Rate

- A. The fission nuclide production rate for the i th fission product nuclide is the product of the fission rate and the fission product yield (γ_i) for the i th fission product:

$$\text{Fission Nuclide Production Rate} = (3 \times 10^{14} \text{ fission / second})(\gamma_i)$$

3. Fission Nuclide Decay Rate

- A. The fission nuclide decay rate for the i th fission product nuclide is the product of the decay constant for the i th fission product nuclide (λ_i), and the number of atoms of the nuclide that are present (N_i):

$$\text{Fission Nuclide Decay Rate} = (\lambda_i)(N_i)$$

4. Fission Product Saturation

- A. Fission product saturation occurs when the production rate and decay rate are the same. Therefore, for the i th fission product, saturation is when:

$$(3 \times 10^{14} \text{ fission / second})(\gamma_i) = (\lambda_i)(N_{i \text{ sat}})$$

- B. Therefore, if we wanted to estimate the number of atoms of the i th fission product in the highest power fuel plate at saturation, it would be:

$$N_{i \text{ sat}} = \left[\frac{3 \times 10^{14} \text{ fission}}{\text{second}} \right] \left[\frac{\gamma_i \text{ atoms}}{\text{fission}} \right] \left[\frac{\text{second}}{\lambda_i} \right]$$

- C. However, if we want to estimate the activity of the i th fission product in the highest power fuel plate at saturation, it would be:

$$\text{Activity (Bq)} = (\lambda_i)(N_{i \text{ sat}}) = (3 \times 10^{14} \text{ fission / second})(\gamma_i)$$

- D. The activity can be converted to units of Ci by using the conversion factor:

$$1 \text{ Ci} = 3.7 \times 10^{10} \text{ Bq}$$

5. As an example, consider I-131 saturation in the core, which has a yield of $\gamma = 0.0277$ atoms per fission, and a decay constant of $\lambda = 9.98 \times 10^{-7}$ per second:

- A. Saturation Activity in the Highest Power Fuel Plate

$$\left[\frac{3 \times 10^{14} \text{ fission}}{\text{second}} \right] \left[\frac{0.0277 \text{ I-131 atoms}}{\text{fission}} \right]$$

$$= 8.3 \times 10^{12} \text{ I-131 atoms per second}$$

$$= 8.3 \times 10^{12} \text{ Bq I-131}$$

$$\left[\frac{8.3 \times 10^{12} \text{ Bq I-131}}{1} \right] \left[\frac{\text{Ci}}{3.7 \times 10^{10} \text{ Bq}} \right]$$

$$= 2.25 \times 10^2 \text{ Ci}$$

- B. Most of the fission products do not get out of the fuel matrix. Of the isotopes that get into the pool water, there is so much solvent in comparison to solute that the vast majority of the isotopes would stay dissolved in the pool water¹⁴. The fission products that are both volatile and long lived enough to potentially escape from the fuel matrix to the pool, as well as the decay constants and cumulative fission yields of each of those isotopes are¹⁵:

Fuel Plate Activity								
Nuclide	Fission	Lamarsh	Number	Lamarsh	Decay	Highest Power	Highest Power	
	Yield	Half Life	of Seconds	Half Life	Constant	Fuel Plate Activity	Fuel Plate Activity	
	(Atoms/Fission)			(s)	(/s)	(Bq)	(Ci)	
I-131	0.0277	8.04 d	8.64E+04	6.95E+05	9.98E-07	8.31E+12	2.25E+02	
I-132	0.0413	2.28 h	3.60E+03	8.21E+03	8.44E-05	1.24E+13	3.35E+02	
I-133	0.0676	20.8 h	3.60E+03	7.49E+04	9.26E-06	2.03E+13	5.48E+02	
I-134	0.0718	52.3 m	6.00E+01	3.14E+03	2.21E-04	2.15E+13	5.82E+02	
I-135	0.0639	6.7 h	3.60E+03	2.41E+04	2.87E-05	1.92E+13	5.18E+02	
Kr-85m	0.0133	4.4 h	3.60E+03	1.58E+04	4.38E-05	3.99E+12	1.08E+02	
Kr-85	0.00285	10.76 y	3.15E+07	3.39E+08	2.04E-09	8.55E+11	2.31E+01	
Kr-87	0.0237	76 m	6.00E+01	4.56E+03	1.52E-04	7.11E+12	1.92E+02	
Kr-88	0.0364	2.79 h	3.60E+03	1.00E+04	6.90E-05	1.09E+13	2.95E+02	
Xe-133m	0.00189	2.26 d	8.64E+04	1.95E+05	3.55E-06	5.67E+11	1.53E+01	
Xe-133	0.0677	5.27 d	8.64E+04	4.55E+05	1.52E-06	2.03E+13	5.49E+02	
Xe-135m	0.0105	15.7 m	6.00E+01	9.42E+02	7.36E-04	3.15E+12	8.51E+01	
Xe-135	0.0672	9.2 h	3.60E+03	3.31E+04	2.09E-05	2.02E+13	5.45E+02	

Note that the fission yields are cumulative, and include not only the yield of the nuclide, but also take into account the yields of the short lived precursors as well.

Activity Available to be Released from the Fuel¹⁶

1. If a fuel plate were to be completely denuded on one side, the amount of the plate activity that would be available to be released into the coolant would depend on the temperature of the fuel, and the surface area of the fuel that is exposed. Since the fuel temperature even during full power operation is very low, diffusion from the fuel matrix into the coolant would be essentially zero. Consequently, the only fission products that would be available to get into the coolant would be from the denuded surface due to the kinetic energy associated with fission fragment recoil.
2. As a result, of the total fission fragment inventory in the damaged fuel plate, the fraction of the activity that could be released to the coolant is the fraction that is in the volume defined by the surface area of the exposed fuel matrix, and the fission fragment recoil depth.

3. Therefore, we can estimate the source term that is available to be released to the coolant by finding the ratio between the volume of the fuel meat that is within the recoil range, to the total volume of the fuel meat. Using the minimum volumes maximizes the activities in each volume, and is therefore conservative.
3. NUREG / CR-2079 PNL-3691 *Analysis of Credible Accidents for Argonaut Reactors* indicates that the range of fission fragment recoil in aluminum is:

$$1.37 \times 10^{-3} \text{ cm}$$

4. For the RINSC reactor, the minimum total volume of the fuel meat is¹⁷:

$$\text{Length} = (22.50 \text{ inches})(2.54 \text{ cm}) / \text{in} = 57.15 \text{ cm}$$

$$\text{Width} = (2.32 \text{ inches})(2.54 \text{ cm}) / \text{in} = 5.89 \text{ cm}$$

$$\text{Thickness} = (0.020 \text{ inches})(2.54 \text{ cm}) / \text{in} = 0.05 \text{ cm}$$

$$\text{Total Fuel Meat Volume} = (57.15 \text{ cm})(5.89 \text{ cm})(0.05 \text{ cm}) = 16.83 \text{ cm}^3$$

5. If a fuel plate were stripped of one side of the cladding, the volume within the recoil range of the fission fragments would be:

$$(57.15 \text{ cm Length})(5.89 \text{ cm Width})(1.37 \times 10^{-3} \text{ cm}) = 0.46 \text{ cm}^3$$

6. The ratio of fission fragments that are available to be released to the coolant, to the total fuel plate fission fragment inventory is:

$$(0.46 \text{ cm}^3)(16.83 \text{ cm}^3) = 0.027 = 2.7\%$$

7. Therefore, the activity that is available to be released from the fuel into the coolant is only 2.7% of the fuel plate activity. Overall:

Source Term		
Nuclide	Highest Power Fuel Plate Activity	Source Term
	(Ci)	(Ci)
I-131	2.25E+02	6.06E+00
I-132	3.35E+02	9.04E+00
I-133	5.48E+02	1.48E+01
I-134	5.82E+02	1.57E+01
I-135	5.18E+02	1.40E+01
Kr-85m	1.08E+02	2.91E+00
Kr-85	2.31E+01	6.24E-01
Kr-87	1.92E+02	5.19E+00
Kr-88	2.95E+02	7.97E+00
Xe-133m	1.53E+01	4.14E-01
Xe-133	5.49E+02	1.48E+01
Xe-135m	8.51E+01	2.30E+00
Xe-135	5.45E+02	1.47E+01

Gap Release

1. During Gap Release, the release fractions from the fuel to the coolant are:
 - A. Iodine 0.05
 - B. Noble Gas 0.05

2. Example Calculation:
 - A. For I-131 we concluded that the saturation activity in the hottest fuel plate would be 2.25×10^2 Ci.
 - B. Of this, the activity in the fuel meat volume that is available to be released to the coolant is:

$$(2.25 \times 10^2 \text{ Ci})(2.7\%) = 6.06 \text{ Ci}$$
 - C. The release fraction for both halogens and noble gases is 0.05 during gap release, so the amount that gets into the coolant during this phase of release is:

$$(0.05)(6.06 \text{ Ci}) = 3.03 \times 10^{-1} \text{ Ci I-131}$$

3. Overall:

Coolant Activity From Gap Release		
Nuclide	Source Term (Ci)	Coolant Activity (Ci)
I-131	6.06E+00	3.03E-01
I-132	9.04E+00	4.52E-01
I-133	1.48E+01	7.40E-01
I-134	1.57E+01	7.86E-01
I-135	1.40E+01	6.99E-01
Kr-85m	2.91E+00	1.46E-01
Kr-85	6.24E-01	3.12E-02
Kr-87	5.19E+00	2.59E-01
Kr-88	7.97E+00	3.98E-01
Xe-133m	4.14E-01	2.07E-02
Xe-133	1.48E+01	7.41E-01
Xe-135m	2.30E+00	1.15E-01
Xe-135	1.47E+01	7.36E-01

4. Release Fractions from Coolant to Confinement Air

- A. Iodine 0.005
- B. Noble Gas 1.0

5. Example Calculations:

A. Iodine

1. The amount of I – 131 the gets into the coolant during gap release is 3.03×10^{-1} Ci I-131.
2. The amount that gets into the confinement air is:
 $(3.03 \times 10^{-1} \text{ Ci})(0.005) = 1.52 \times 10^{-3} \text{ Ci}$

B. Noble Gas

1. The amount of Kr – 85m the gets into the coolant during gap release is 1.46×10^{-1} Ci.
2. The amount that gets into the confinement air is:
 $(1.46 \times 10^{-1} \text{ Ci})(1) = 1.46 \times 10^{-1} \text{ Ci Kr – 85m}$

6. Total Activity in Confinement Air Due to Gap Release

Confinement Air Activity From Gap Release		
Nuclide	Coolant Activity (Ci)	Confinement Air Activity (Ci)
I-131	3.03E-01	1.52E-03
I-132	4.52E-01	2.26E-03
I-133	7.40E-01	3.70E-03
I-134	7.86E-01	3.93E-03
I-135	6.99E-01	3.50E-03
Kr-85m	1.46E-01	1.46E-01
Kr-85	3.12E-02	3.12E-02
Kr-87	2.59E-01	2.59E-01
Kr-88	3.98E-01	3.98E-01
Xe-133m	2.07E-02	2.07E-02
Xe-133	7.41E-01	7.41E-01
Xe-135m	1.15E-01	1.15E-01
Xe-135	7.36E-01	7.36E-01

7. Duration of Gap Phase

A. The Gap Phase of release begins at time zero, and continues for 0.5 hours.

8. Confinement Air Gap Activity Build-Up Rate

A. Rate of Activity Released = Total Activity Released / 0.5 Hours

B. For I-131

$$\text{Rate of I-131 Release} = (1.52 \times 10^{-3}) / (0.5 \text{ Hours}) = 3.03 \times 10^{-3} \text{ Ci / hr}$$

C. Overall:

Confinement Air Gap Activity Build-UP Rate		
Nuclide	Total Gap Release	Gap Activity
	Confinement Air	Build-Up
	Activity	Rate
	(Ci)	(Ci / hr)
I-131	1.52E-03	3.03E-03
I-132	2.26E-03	4.52E-03
I-133	3.70E-03	7.40E-03
I-134	3.93E-03	7.86E-03
I-135	3.50E-03	6.99E-03
Kr-85m	1.46E-01	2.91E-01
Kr-85	3.12E-02	6.24E-02
Kr-87	2.59E-01	5.19E-01
Kr-88	3.98E-01	7.97E-01
Xe-133m	2.07E-02	4.14E-02
Xe-133	7.41E-01	1.48E+00
Xe-135m	1.15E-01	2.30E-01
Xe-135	7.36E-01	1.47E+00

9. Confinement Volume

A negative pressure is maintained in the confinement building so that all of the air that exits the building will exit through a stack. If an airborne RAM release is detected, the Emergency Air Handling System is activated, and the airflow is directed through an emergency filter prior to reaching the stack.

During facility re-licensing, the volume of the confinement building was determined to be approximately 203,695 cubic feet. The volume of the pool structure and water was determined to be 21,740 cubic feet, leaving 181,955 cubic feet of open space. The control room takes up about 3,612 cubic feet of this space. Converting the free volume of the confinement room to cubic centimeters:

$$\left[\frac{181955 \text{ ft}^3}{1} \right] \left[\frac{(12 \text{ in})^3}{\text{ft}^3} \right] \left[\frac{(2.54 \text{ cm})^3}{(\text{in})^3} \right] = 5.15 \times 10^9 \text{ cm}^3$$

10. Confinement Air Concentration Build-Up Rate

- A. If we make the assumption that all of the activity is dispersed uniformly in the confinement volume, the rate at which the concentrations of each isotope increase is:

$$(\text{Activity Build-Up Rate}) / (\text{Confinement Volume})$$

- B. For I-131

$$\begin{aligned} \text{Concentration Build-Up Rate} &= (3.03 \times 10^{-3} \text{ Ci / hr}) / (5.15 \times 10^9 \text{ cc}) \\ &= 5.88 \times 10^{-13} \text{ Ci / cc per hour} \end{aligned}$$

- C. Overall

Gap Phase Confinement Activity Concentration Rate (0 to 0.5 Hours)			
	Gap Release	Confinement Air	Confinement Air
	Confinement Air	Gap Activity	Gap Concentration
	Activity	Build-Up Rate	Build-Up Rate
	(Ci)	(Ci / hr)	(Ci / cc-hr)
I-131	1.52E-03	3.03E-03	5.89E-13
I-132	2.26E-03	4.52E-03	8.78E-13
I-133	3.70E-03	7.40E-03	1.44E-12
I-134	3.93E-03	7.86E-03	1.53E-12
I-135	3.50E-03	6.99E-03	1.36E-12
Kr-85m	1.46E-01	2.91E-01	5.65E-11
Kr-85	3.12E-02	6.24E-02	1.21E-11
Kr-87	2.59E-01	5.19E-01	1.01E-10
Kr-88	3.98E-01	7.97E-01	1.55E-10
Xe-133m	2.07E-02	4.14E-02	8.03E-12
Xe-133	7.41E-01	1.48E+00	2.88E-10
Xe-135m	1.15E-01	2.30E-01	4.46E-11
Xe-135	7.36E-01	1.47E+00	2.86E-10

11. Emergency Filter Release Fraction

- A. When the Emergency Air Handling System is activated, all of the air from the confinement room is exhausted through an emergency filter. The emergency filter consists of:

1. Roughing Filter
 2. HEPA Filter
 3. Charcoal Filter
 4. HEPA Filter
- B. The proposed Technical Specifications associated with the Emergency Filter efficiency are:
- 3.5.2.3 The emergency filter shall be at least 99% efficient at removing iodine.
 - 3.5.2.4 The Emergency Filter System Exhaust Absolute Filter shall be certified by the manufacturer to have a minimum efficiency of 99.97% for removing 0.3 micron diameter particulates.
- C. There are two sets of HEPA filters that the concentration of airborne particles must go through, so the concentration of particles that are 0.3 microns or greater in the confinement room that will reach the stack is:
- $$(0.03\%)(0.03\%)(\text{Confinement Concentration})$$
- $$= (0.0009\%)(\text{Confinement Concentration})$$
- $$= (0.00009)(\text{Confinement Concentration})$$
- $$= (9 \times 10^{-5})(\text{Confinement Concentration})$$
- D. Of the iodine that reaches the stack, only the non-organic iodine is adsorbed by the charcoal filter. The organic iodine is not adsorbed.
- E. The concentration of non-organic iodine in the confinement room that will reach the stack is:
- $$(1\%)(\text{Confinement Concentration})$$
- $$= (0.01)(\text{Confinement Concentration})$$
- F. The noble gases are unaffected by the HEPA filters, but are slowed by the charcoal filter. We will assume that all of the noble gases are released to the stack.
- G. If we continue with our I-131 example:
1. We concluded that the concentration build-up rate for I-131 in the confinement air was $5.89\text{E-}13 \text{ Ci / cm}^3$ per hour.

2. Therefore, if the concentration were to build up for the entire 0.5 hr duration of the gap release, without exhausting any of it through the stack, the concentration would be:

$$(5.89 \times 10^{-13} \text{ Ci / cc - hour})(0.5 \text{ hour}) = 2.95 \times 10^{-13} \text{ Ci / cc}$$

3. Of this concentration of iodine, the relative amounts of organic and non-organic iodine are:

$$(43\% \text{ Organic Iodine})(2.95 \times 10^{-13} \text{ Ci / cc}) = 1.27 \times 10^{-13} \text{ Ci / cc}$$

$$(57\% \text{ Non-Organic Iodine})(2.95 \times 10^{-13} \text{ Ci / cc}) = 1.68 \times 10^{-13} \text{ Ci / cc}$$

4. All of the organic Iodine is assumed to get through the filter, and only 1% of the non-organic iodine is assumed to get through. Therefore, the total amount that gets through the filter is:

$$1.27 \times 10^{-13} \text{ Ci / cc} + (0.01)(1.68 \times 10^{-13} \text{ Ci / cc}) = 1.28 \times 10^{-13} \text{ Ci / cc}$$

5. Overall

Emergency Filter Release Concentrations					
	Confinement Air	Final	Concentration	Concentration	Emergency Filter
	Gap Concentration	Gap Activity	of Organic	of Non-Organic	Release
	Build-Up Rate	Concentration	Iodine	Iodine	Concentration
	(Ci / cc-hr)	(Ci / cc)	(Ci / cc)	(Ci / cc)	(Ci / cc)
I-131	5.89E-13	2.94E-13	1.27E-13	1.68E-13	1.28E-13
I-132	8.78E-13	4.39E-13	1.89E-13	2.50E-13	1.91E-13
I-133	1.44E-12	7.18E-13	3.09E-13	4.09E-13	3.13E-13
I-134	1.53E-12	7.63E-13	3.28E-13	4.35E-13	3.32E-13
I-135	1.36E-12	6.79E-13	2.92E-13	3.87E-13	2.96E-13
Kr-85m	5.65E-11	2.83E-11			2.83E-11
Kr-85	1.21E-11	6.06E-12			6.06E-12
Kr-87	1.01E-10	5.04E-11			5.04E-11
Kr-88	1.55E-10	7.74E-11			7.74E-11
Xe-133m	8.03E-12	4.02E-12			4.02E-12
Xe-133	2.88E-10	1.44E-10			1.44E-10
Xe-135m	4.46E-11	2.23E-11			2.23E-11
Xe-135	2.86E-10	1.43E-10			1.43E-10

12. Therefore, the concentration of the nuclides that enter into the stack, is equivalent to the concentrations that are released from the emergency filter.

13. Radioactive Material Release Rate

- A. The dispersion calculations use radioactive material release rates, rather than activity concentrations.
- B. The rate at which RAM is exhausted from the stack is equivalent to the rate at which it is exhausted from the emergency filter.

- C. The higher the filter exhaust flow rate, the higher the RAM release rate from the stack.
- D. Technical Specification 3.5.2.2 limits flow through the emergency filter to a maximum of 1500 cfm.

$$\left[\frac{1500 \text{ ft}^3}{\text{min}} \right] \left[\frac{(12 \text{ in})^3}{\text{ft}^3} \right] \left[\frac{(2.54 \text{ cm})^3}{(\text{in})^3} \right] \left[\frac{\text{min}}{60 \text{ s}} \right] = 7.08 \times 10^5 \text{ cm}^3 / \text{s}$$

- E. Therefore, the RAM release rate from the stack is:

$$\left[\frac{\text{Emergency Filter Exhaust Concentration Ci}}{\text{cm}^3} \right] \left[\frac{\text{Emergency Filter Exhaust Flowrate cm}^3}{\text{s}} \right] = \frac{\text{Ci}}{\text{s}}$$

- F. Continuing with the I-131 example, the concentration of I-131 in the emergency filter exhaust was $1.28 \times 10^{-13} \text{ Ci} / \text{cm}^3$, so the I-131 release rate is:

$$\left[\frac{1.28 \times 10^{-13} \text{ Ci}}{\text{cm}^3} \right] \left[\frac{7.08 \times 10^5 \text{ cm}^3}{\text{s}} \right] = 9.06 \times 10^{-8} \text{ Ci} / \text{s}$$

- E. Overall:

Stack RAM Release Rate		
	Initial	Stack
	Stack	RAM Release
	Concentration	Rate
	(Ci / cc)	(Ci / s)
I-131	1.28E-13	9.08E-08
I-132	1.91E-13	1.35E-07
I-133	3.13E-13	2.22E-07
I-134	3.32E-13	2.35E-07
I-135	2.96E-13	2.09E-07
Kr-85m	2.83E-11	2.00E-05
Kr-85	6.06E-12	4.29E-06
Kr-87	5.04E-11	3.57E-05
Kr-88	7.74E-11	5.48E-05
Xe-133m	4.02E-12	2.84E-06
Xe-133	1.44E-10	1.02E-04
Xe-135m	2.23E-11	1.58E-05
Xe-135	1.43E-10	1.01E-04

14. Atmospheric Dispersion

A. Air Turbulance Conditions

1. Non-Fumigation Conditions

Atmospheric stability is a measure of the turbulence in the plume, and it affects the rate of the dispersion of the plume. The more turbulent the air is, the greater the dispersion rate. There are six classifications of atmospheric stability, ranging from Pasquill Type A through Pasquill Type F, in which A is extremely unstable, and F is moderately stable. While this suggests that Pasquill Type F is conservative because it minimizes the dispersion rate and maximizes the airborne RAM concentrations at ground level, it is not necessarily the most conservative from the standpoint of the distance at which the plume reaches ground level. Consequently, Pasquill Types B, D, and F were considered.

2. Fumigation Conditions

Fumigation is a condition in which there is an air inversion above the stack release which forces the plume to stay below the inversion. As a result, under fumigation conditions, the plume reaches the ground level at distances that are much shorter than what occurs under non-fumigation conditions. NRC Regulatory Guide 1.145 Section 2.1.2.b indicates that for coastal sites that are located less than 3.2 kilometers from a large body of water, fumigation conditions should be assumed to exist. Since the stack is approximately 150 meters from the Narragansett Bay, fumigation conditions were also considered.

3. Conditions Under Consideration

Initially for this analysis, an air turbulence condition of Pasquill F type was considered because it was assumed that this level of air stability would result in the highest concentration of RAM when the plume reached ground level. NRC pointed out that this assumption might not give the most conservative results because under more turbulent conditions, the plume reaches ground level much sooner than under stable conditions. They suggested that stability types Pasquill B and D be considered. Additionally, given the facility's proximity to a large body of water, the guidance indicated that fumigation conditions must also be considered. Consequently, non-fumigation conditions Pasquill B, D, and F were considered, as well as the fumigation condition.

B. Dispersion Equations

Atmospheric dispersion calculations estimate the concentration of some material in air for a given release rate, under specified atmospheric conditions, at some distance away from the source. A Gaussian Straight Line Plume Model is used.

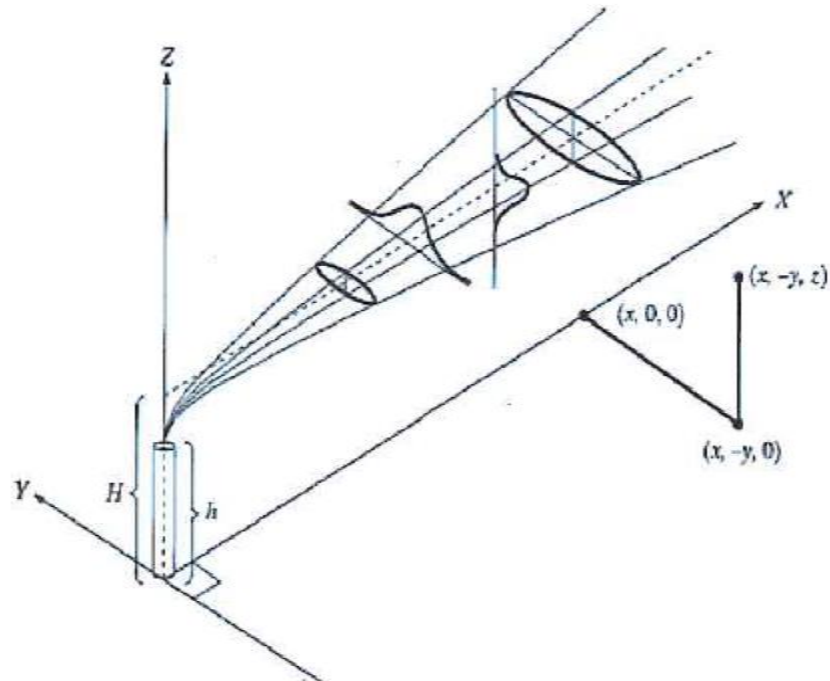

1. Non-Fumigation Equation

Section 1.3.2.a of NRC Regulatory Guide 1.145 (November 1982 Rev. 1) indicates that the equation for stack releases under nonfumigation conditions is:

$$\frac{\chi}{Q} = \frac{1}{\pi \sigma_y \sigma_z u_h} e^{\left[\frac{-h_e^2}{2\sigma_z^2} \right]}$$

2. Fumigation Equation

Section 1.3.2.b of NRC Regulatory Guide 1.145 (November 1982 Rev. 1) indicates that the equation for stack releases under nonfumigation conditions is:

$$\frac{\chi}{Q} = \frac{1}{(2\pi)^{1/2} \sigma_y u_{he} h_e}$$

3. The factors for these equations are:
- A. X is the concentration of the material in the air (Activity / Volume)
 - B. Q is the material release rate (Activity / Time)
 - C. σ_y is the horizontal dispersion coefficient (Distance)
 - D. σ_z is the vertical dispersion coefficient (Distance)
 - E. h_s is the stack height above the plant grade (Distance)
 - F. h_t is the maximum terrain height above plant grade between the release point, and the point of interest (Distance)
 - G. h_e is the effective stack height = $h_s - h_t$ with $h_e = 0$ if $h_t > h_s$ (Distance)
 - H. u_h is the average wind speed of the plume at the release height (Distance / Time)
 - I. u_{he} is the average wind speed of the fumigation layer at the effective stack height (Distance / Time)
 - J. x is the downwind distance (Distance)
 - K. y is the horizontal distance at right angles to the plume centerline (Distance)
 - L. z is the height above the ground (Distance)

C. Stack Height

The release is at the level of the stack ($h_s = 115$ ft), with no significant change in terrain height between the release point and the site boundary ($h_t = 0$), so the effective stack height is:

$$\begin{aligned} h_e &= h_s - h_t = 35\text{m} = 0 = 115 \text{ ft} \\ &= (115 \text{ ft})(12 \text{ in} / \text{ft})(2.54 \text{ cm} / \text{in})(\text{m} / 100 \text{ cm}) \\ &= 35.052 \text{ m} \end{aligned}$$

D. Wind Direction

Wind direction is assumed to be constant, As a result, all of the concentration of RAM will be along one line of direction, rather than dispersed across more than one direction. Consequently, this assumption is conservative.

E. Wind Speed

The wind speed is assumed to be one meter per second. Higher wind speeds increase dilution because the RAM released per unit time is added to a larger

volume of air passing by the release point. Consequently, this assumption is conservative.

F. Coordinates of Interest

The dispersion coefficients are quantitative measures of how much the plume spreads out in the horizontal (y) and vertical (z) directions at some given distance (x) down wind of the release point. The material concentration in the plume as a function of distance from the plume centerline is a Gaussian distribution, with maximum concentration at the centerline. The dispersion coefficients are the standard deviations in each direction. Therefore, 68% of the plume is within σ_y distance from the centerline in the y – direction, and σ_z distance from the centerline in the z – direction. For this analysis, the y and z values are taken to be zero so that the concentrations calculated will be associated with the centerline of the plume, and therefore will be the most conservative.

The distance between the confinement stack and the site boundary is 50 meters. RINSC has the authority to prevent the public from entering this boundary.

The facility sits on the Bay Campus of the University of Rhode Island. There are residential areas to the north and south of the campus. To the west of the campus, woods and businesses abut the campus. To the northwest along South Ferry Road, there are residences as well. Using Google Maps to estimate the distances between the stack release point, and the residences to the north, northwest, and south, the nearest residence was determined to be 500 meters from the stack:

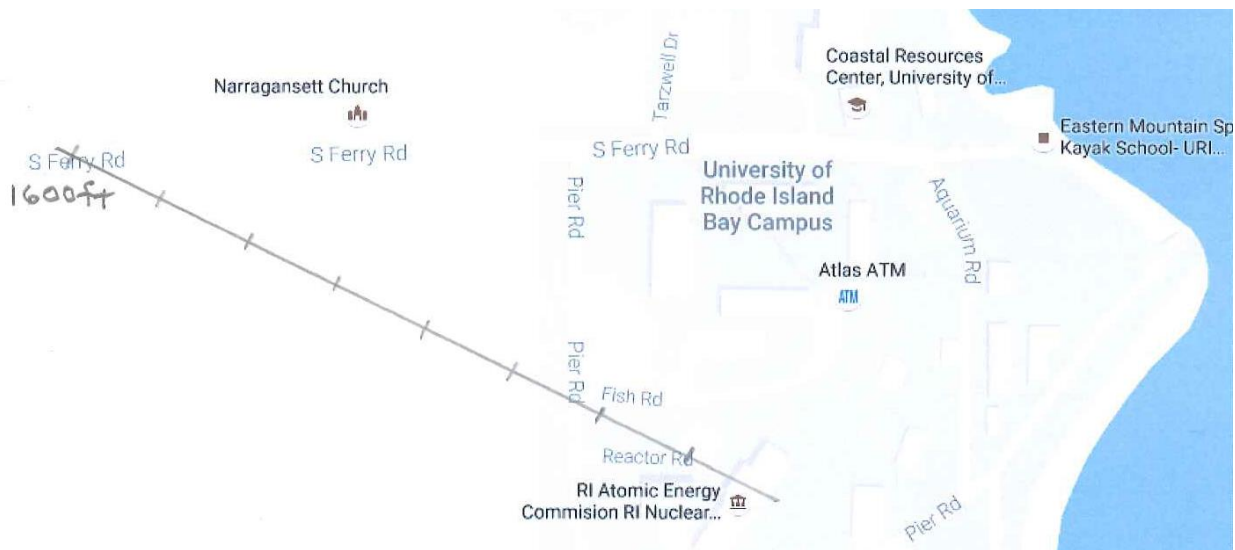

Nearest Residence on South Ferry Road



Distance to Nearest Residence in Saunderstown

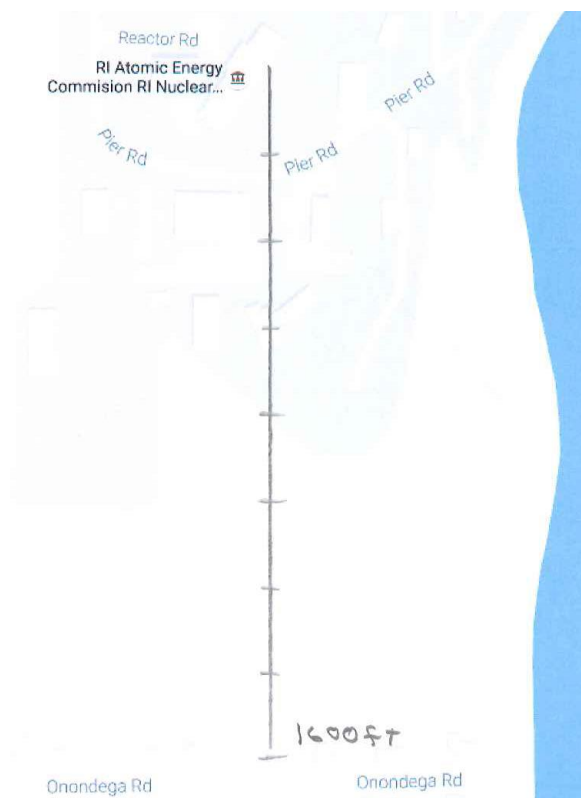

Nearest Residence in Bonnet Shores

Therefore the closest residence is 1600 feet from the stack:

$$(1600 \text{ ft})(\text{m} / 3.28 \text{ ft}) = 487.8 \text{ m} \approx 500 \text{ m}$$

The maximum concentration point occurs when ^{Need Reference:}

$$2(\sigma_z)^2 = (h_e)^2$$

$$\sigma_z = \left[\frac{h_e^2}{2} \right]^{1/2}$$

From this, the maximum concentration point is the x distance from the stack that corresponds to the σ_z that was calculated.

In addition to calculating where the maximum concentration point occurs, numerical methods were used to verify that it occurs where it is predicted to occur.

Consequently, the three points down wind of the stack that we are interested in knowing the RAM concentrations at ground level are:

1. Site Boundary (x = 50 meters)
2. Nearest Residence (x = 500 meters)
3. Maximum concentration point

The dispersion coefficients take these distances into account. The dispersion coefficient curves given in the US Atomic Energy Commission's "Meteorology and Atomic Energy, 1968", pp. 102 – 103 are:

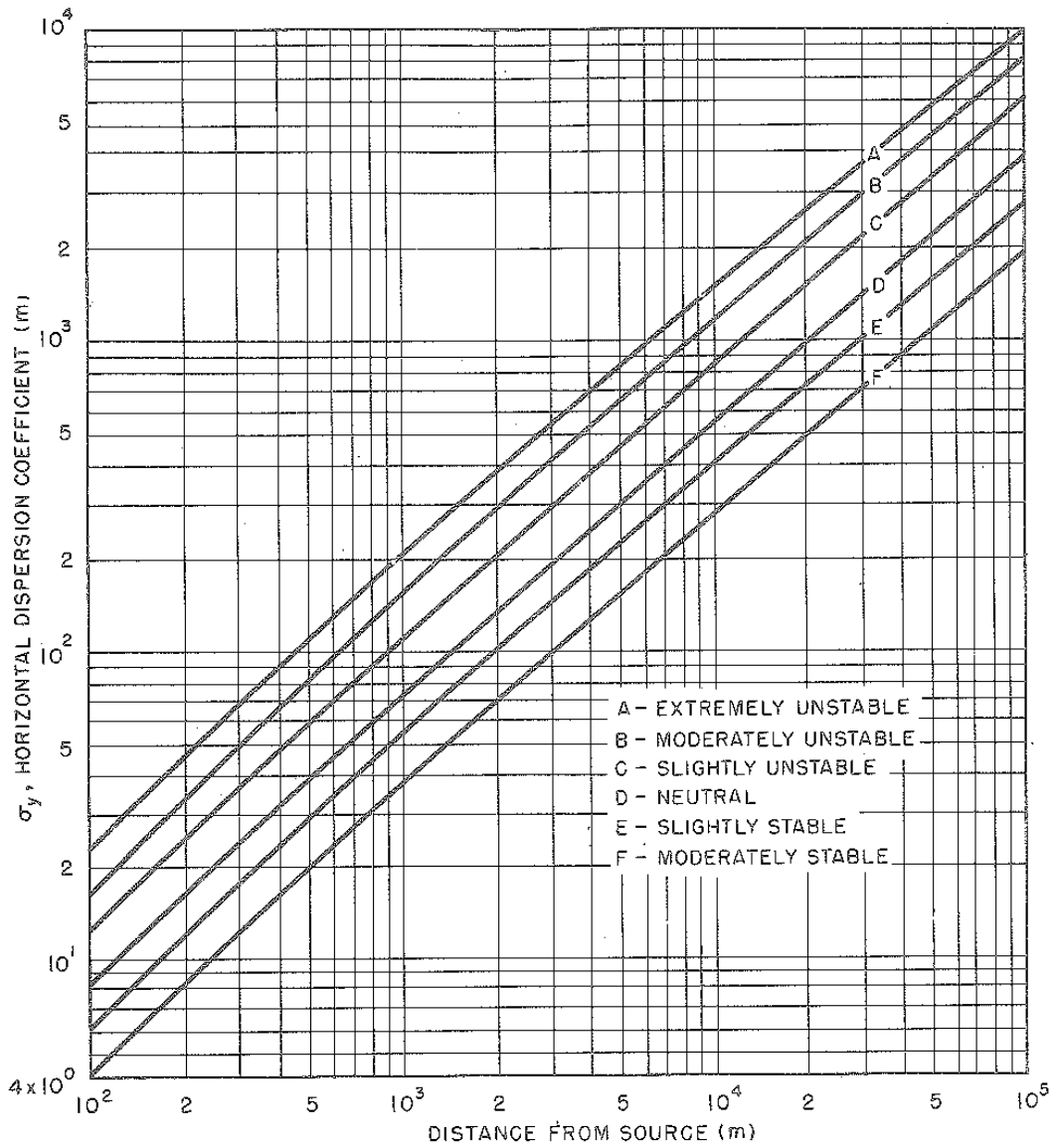

Fig. 3.10—Lateral diffusion, σ_y , vs. downwind distance from source for Pasquill's turbulence types.

DIFFUSION IN THE LOWER LAYERS OF THE ATMOSPHERE

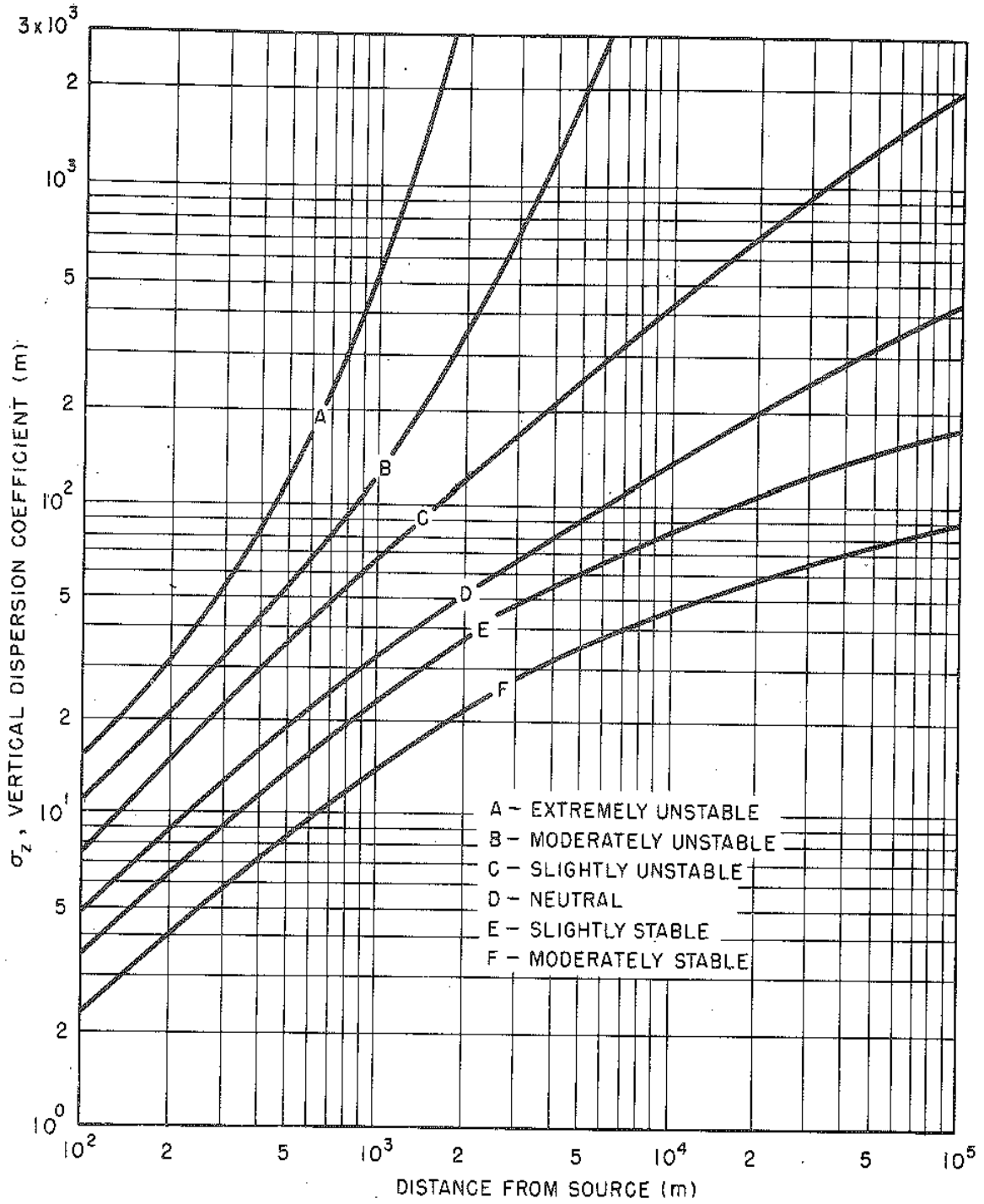

Fig. 3.11—Vertical diffusion, σ_z , vs. downwind distance from source for Pasquill's turbulence types.

G. Non-Fumigation Example Calculation for Site Boundary Concentrations Under Pasquill F Conditions

1. The Site Boundary distance from the stack is 50 meters.
2. The σ_y dispersion coefficient at 50 meters is:

Using linear extrapolation to determine what σ_y is at 50 meters for the Pasquill F curve on the σ_y vs. x graph, two data points are:

$$\begin{array}{ll} x_1 = 100 \text{ m} & y_1 = 4 \text{ m} \\ x_2 = 200 \text{ m} & y_2 = 8 \text{ m} \end{array}$$

The slope of the line is:

$$m = \frac{(y_2 - y_1)}{(x_2 - x_1)} = \frac{(8 \text{ m} - 4 \text{ m})}{(200 \text{ m} - 100 \text{ m})} = \frac{4 \text{ m}}{100 \text{ m}} = 0.04$$

The point – slope form of the line is:

$$(y_2 - y_1) = m(x_2 - x_1)$$

The y – intercept occurs at point (0,b):

$$(y_2 - b) = m(x_2 - 0)$$

$$(y_2 - b) = mx_2$$

$$y_2 - mx_2 = b$$

$$b = y_2 - mx_2$$

$$b = (8 \text{ m}) - (0.04)(200 \text{ m}) = 0.0 \text{ m}$$

Consequently, the general equation is:

$$y = mx + b$$

$$y = (0.04) x + 0.0 \text{ m}$$

For our case $x = 50 \text{ m}$, so σ_y is:

$$\sigma_y = y = (0.04)(50 \text{ m}) + 0.0 \text{ m} = 2.0 \text{ m}$$

3. The σ_z dispersion coefficient at 50 meters is:

Using linear extrapolation to determine what σ_y is at 50 meters for the Pasquill F curve on the σ_y vs. x graph, two data points are:

$$\begin{array}{ll} x_1 = 100 \text{ m} & y_1 = 2.4 \text{ m} \\ x_2 = 200 \text{ m} & y_2 = 4 \text{ m} \end{array}$$

The slope of the line is:

$$m = \frac{(y_2 - y_1)}{(x_2 - x_1)} = \frac{(4 \text{ m} - 2.4 \text{ m})}{(200 \text{ m} - 100 \text{ m})} = \frac{1.6 \text{ m}}{100 \text{ m}} = 0.016$$

The point – slope form of the line is:

$$(y_2 - y_1) = m(x_2 - x_1)$$

The y – intercept occurs at point (0,b):

$$(y_2 - b) = m(x_2 - 0)$$

$$(y_2 - b) = mx_2$$

$$y_2 - mx_2 = b$$

$$b = y_2 - mx_2$$

$$b = (4 \text{ m}) - (0.016)(200 \text{ m}) = 0.8 \text{ m}$$

Consequently, the general equation is:

$$y = mx + b$$

$$y = (0.016)x + 0.8 \text{ m}$$

For our case $x = 50 \text{ m}$, so σ_z is:

$$\sigma_z = y = (0.016)(48 \text{ m}) + 0.08 \text{ m} = 1.6 \text{ m}$$

4. Therefore, the dispersion coefficients for a distance of 50 meters from the stack, under non-fumigation conditions, with Pasquill Type F turbulence are:

$$\sigma_y = 2.0 \text{ meters}$$

$$\sigma_z = 1.6 \text{ meters}$$

5. Consequently, the values of each of the factors in the non-fumigation dispersion equation are:

$$\begin{aligned}h_e &= 35.052 \text{ m} \\u_h &= 1 \text{ m / s} \\ \sigma_y &= 2.0 \text{ m} \\ \sigma_z &= 1.6 \text{ m}\end{aligned}$$

6. Plugging these values into the non-fumigation dispersion equation:

$$\frac{\chi}{Q} = \frac{1}{\pi \sigma_y \sigma_z u_h} e^{\left[\frac{-h_e^2}{2\sigma_z^2}\right]}$$

$$\frac{\chi}{Q} = \frac{1}{\pi (2\text{m})(1.6\text{m})(1\text{m/s})} e^{\left[\frac{-(35.052\text{m})^2}{2(1.6\text{m})^2}\right]} = \frac{1}{10.0531 \text{ m}^3 / \text{s}} e^{-239.97}$$

$$\frac{\chi}{Q} = 6.03 \times 10^{-106} \text{ s / m}^3$$

Converting the volume to units of cm^3 :

$$\frac{\chi}{Q} = (6.03 \times 10^{-106} \text{ s / m}^3)(\text{m / 100 cm})^3 = 6.03 \times 10^{-112} \text{ s / cm}^3$$

7. Using this to convert the stack release rate of I-131 into a concentration:

For I-131, the release rate out of the stack was $9.08 \times 10^{-8} \text{ Ci / s}$.

$$(9.08 \times 10^{-8} \text{ Ci / s})(6.03 \times 10^{-112} \text{ s / cm}^3) = 5.4 \times 10^{-119} \text{ Ci / cm}^3$$

This is the concentration of I-131 at ground level, at a distance of 50 meters down wind of the stack, if the air turbulence condition is Pasquill F, and the wind speed is 1 m / s.

H. Methodology for Determining Concentrations at the Site Boundary, Nearest Residential, and Maximum Concentration Points

1. In order to get a sense of where the maximum concentration point is, dispersion coefficients were determined for distances ranging from the 50 meter site boundary point, to 10,000 meters out from the stack, including the 500 meter residential point.

2. X/Q was calculated for each of these distances.
3. Isotope concentrations were calculated for each of these distances, and the distance with the highest concentration data was highlighted.
4. A second set of dispersion coefficients were determined for distances at smaller increments around the point of maximum concentration found in the first set of data, in order to get a more precise location.
5. X/Q was calculated for each of these new distances.
6. Isotope concentrations were calculated for each of these new distances, and the distance with the highest concentration data was highlighted. The distance associated with these concentrations is the maximum concentration point.
7. Additionally, the point of maximum concentration was also calculated using the following formula ^{Need formal reference for Ronald Fjeld, Quantitative Environmental Risk Analysis :}

$$2(\sigma_z)^2 = (h_e)^2$$

and solving for σ_z .

The σ_z vs. x graph was used to determine the distance x associated with the calculated value of σ_z . This distance is the predicted point of maximum concentration point.

8. For each case, both methods for determining the maximum concentration point were found to be consistent with each other.

H. Pasquill B Condition Results

Atmospheric Dispersion Calculator																
π	=	3.141593		Stack RAM Release Rate (Ci / s)	Site Boundary 50 m Concentration (Ci / cc)	200 m Concentration (Ci / cc)	Nearest Residence				5000 m Concentration (Ci / cc)	10000 m Concentration (Ci / cc)				
h(s)	=	115 ft	= 35.052 m	I-131	9.08E-08	2.54E-20	8.90E-18	5.09E-18	1.36E-18	2.72E-19	1.45E-20	0.00E+00				
h(t)	=	0 ft	= 0 m	I-132	1.35E-07	3.79E-20	1.33E-17	7.58E-18	2.03E-18	4.06E-19	2.17E-20	0.00E+00				
h(e)	=	115 ft	= 35.052 m	I-133	2.22E-07	6.20E-20	2.17E-17	1.24E-17	3.32E-18	6.65E-19	3.55E-20	0.00E+00				
h(e)^2	=		= 1228.643 m^2	I-134	2.35E-07	6.59E-20	2.31E-17	1.32E-17	3.53E-18	7.06E-19	3.77E-20	0.00E+00				
$\sigma(y)$	=	85 m		I-135	2.09E-07	5.87E-20	2.05E-17	1.17E-17	3.14E-18	6.28E-19	3.35E-20	0.00E+00				
$\sigma(z)$	=	55 m		Kr-85m	2.00E-05	5.60E-18	1.96E-15	1.12E-15	3.00E-16	6.00E-17	3.20E-18	0.00E+00				
$\sigma(z)^2$	=	3025 m^2		Kr-85	4.29E-06	1.20E-18	4.20E-16	2.40E-16	6.43E-17	1.29E-17	6.86E-19	0.00E+00				
U(h)	=	1 m/s		Kr-87	3.57E-05	9.99E-18	3.50E-15	2.00E-15	5.35E-16	1.07E-16	5.71E-18	0.00E+00				
X/Q	=	5.56E-05 s/m^3	= 5.6E-11 s/cm^3	Kr-88	5.48E-05	1.53E-17	5.37E-15	3.07E-15	8.22E-16	1.64E-16	8.76E-18	0.00E+00				
				Xe-133m	2.84E-06	7.96E-19	2.79E-16	1.59E-16	4.27E-17	8.53E-18	4.55E-19	0.00E+00				
				Xe-133	1.02E-04	2.85E-17	9.98E-15	5.71E-15	1.53E-15	3.06E-16	1.63E-17	0.00E+00				
				Xe-135m	1.58E-05	4.42E-18	1.55E-15	8.85E-16	2.37E-16	4.74E-17	2.53E-18	0.00E+00				
				Xe-135	1.01E-04	2.83E-17	9.91E-15	5.66E-15	1.52E-15	3.03E-16	1.62E-17	0.00E+00				
				Paquill B	50 m X/Q (s / cc)	200 m X/Q (s / cc)	500 m X/Q (s / cc)	1000 m X/Q (s / cc)	2000 m X/Q (s / cc)	5000 m X/Q (s / cc)	10000 m X/Q (s / cc)					
				$\sigma(y)$	9.5	35	85	160	300	650	1250					
				$\sigma(z)$	8	20	55	130	350	3000						
				X/Q	2.8E-13	9.8E-11	5.6E-11	1.5E-11	3.0E-12	1.6E-13						
				Calculated Maximum Concentration Point $2\sigma(z)^2 = h(e)^2$												
h(e)^2	=	1228.643 m^2														
$\sigma(z)^2$	=	614.3214 m^2														
$\sigma(z)$	=	25 m														
x[$\sigma(z)=25$]	=	250 m														
				Linear Extrapolation Data for X/Q at 50 m												
$\sigma(y)$	=	100 m		I-131	9.08E-08	2.54E-20	1.91E-18	4.99E-18	8.90E-18	1.18E-17	9.99E-18	8.26E-18	6.99E-18	5.09E-18		
x1	=	200 m		I-132	1.35E-07	3.79E-20	2.84E-18	7.45E-18	1.33E-17	1.76E-17	1.49E-17	1.23E-17	1.04E-17	7.58E-18		
$\sigma(y1)$	=	18 m		I-133	2.22E-07	6.20E-20	4.65E-18	1.22E-17	2.17E-17	2.88E-17	2.44E-17	2.02E-17	1.71E-17	1.24E-17		
$\sigma(y2)$	=	35 m		I-134	2.35E-07	6.59E-20	4.94E-18	1.29E-17	2.31E-17	3.06E-17	2.59E-17	2.14E-17	1.81E-17	1.32E-17		
m	=	0.17		I-135	2.09E-07	5.87E-20	4.40E-18	1.15E-17	2.05E-17	2.72E-17	2.30E-17	1.91E-17	1.61E-17	1.17E-17		
b	=	1		Kr-85m	2.00E-05	5.60E-18	4.20E-16	1.10E-15	1.96E-15	2.60E-15	2.20E-15	1.82E-15	1.54E-15	1.12E-15		
x(50 m)	=	9.5		Kr-85	4.29E-06	1.20E-18	9.01E-17	2.36E-16	4.20E-16	5.58E-16	4.72E-16	3.90E-16	3.30E-16	2.40E-16		
				Kr-87	3.57E-05	9.99E-18	7.49E-16	1.96E-15	3.50E-15	4.64E-15	3.92E-15	3.25E-15	2.75E-15	2.00E-15		
				Kr-88	5.48E-05	1.53E-17	1.15E-15	3.01E-15	5.37E-15	7.12E-15	6.03E-15	4.98E-15	4.22E-15	3.07E-15		
				Xe-133m	2.84E-06	7.96E-19	5.97E-17	1.56E-16	2.79E-16	3.70E-16	3.13E-16	2.59E-16	2.19E-16	1.59E-16		
				Xe-133	1.02E-04	2.85E-17	2.14E-15	5.60E-15	9.98E-15	1.32E-14	1.12E-14	9.27E-15	7.84E-15	5.71E-15		
				Xe-135m	1.58E-05	4.42E-18	3.32E-16	8.69E-16	1.55E-15	2.05E-15	1.74E-15	1.44E-15	1.22E-15	8.85E-16		
				Xe-135	1.01E-04	2.83E-17	2.12E-15	5.56E-15	9.91E-15	1.31E-14	1.11E-14	9.20E-15	7.79E-15	5.66E-15		
				Paquill B	50 m X/Q (s / cc)	100 m X/Q (s / cc)	150 m X/Q (s / cc)	200 m X/Q (s / cc)	250 m X/Q (s / cc)	300 m X/Q (s / cc)	350 m X/Q (s / cc)	400 m X/Q (s / cc)	500 m X/Q (s / cc)			
$\sigma(z)$	=	100 m		$\sigma(y)$	9.5	18	25	35	40	50	60	68	85			
x1	=	200 m		$\sigma(z)$	8	12	15	20	28	32	38	44	55			
$\sigma(z1)$	=	12 m		X/Q	2.8E-13	2.1E-11	5.5E-11	9.8E-11	1.3E-10	1.1E-10	9.1E-11	7.7E-11	5.6E-11			
$\sigma(z2)$	=	20 m														
m	=	0.08														
b	=	4														
x(50 m)	=	8														

I. Pasquill D Condition Results

Atmospheric Dispersion Calculator				Stack RAM Release Rate (Ci / s)	Site Boundary 50 m Concentration (Ci / cc)	200 m Concentration (Ci / cc)	Nearest Residence 500 m Concentration (Ci / cc)	1000 m Concentration (Ci / cc)	2000 m Concentration (Ci / cc)	5000 m Concentration (Ci / cc)	10000 m Concentration (Ci / cc)				
π	=	3.141593			I-131	9.08E-08	5.45E-45	9.99E-20	7.81E-18	6.90E-18	3.09E-18	1.18E-18	3.45E-19		
$h(s)$	=	115 ft	=	35.052 m	I-132	1.35E-07	8.12E-45	1.49E-19	1.16E-17	1.03E-17	4.60E-18	1.76E-18	5.14E-19		
$h(t)$	=	0 ft	=	0 m	I-133	2.22E-07	1.33E-44	2.44E-19	1.91E-17	1.68E-17	7.53E-18	2.88E-18	8.42E-19		
$h(e)$	=	115 ft	=	35.052 m	I-134	2.35E-07	1.41E-44	2.59E-19	2.02E-17	1.79E-17	8.00E-18	3.06E-18	8.94E-19		
$h(e)^2$	=		=	1228.643 m ²	I-135	2.09E-07	1.26E-44	2.30E-19	1.80E-17	1.59E-17	7.12E-18	2.72E-18	7.96E-19		
$\sigma(y)$	=	72 m			Kr-85m	2.00E-05	1.20E-42	2.20E-17	1.72E-15	1.52E-15	6.80E-16	2.60E-16	7.61E-17		
$\sigma(z)$	=	33 m			Kr-85	4.29E-06	2.57E-43	4.72E-18	3.69E-16	3.26E-16	1.46E-16	5.58E-17	1.63E-17		
$\sigma(z)^2$	=	1089 m ²			Kr-87	3.57E-05	2.14E-42	3.92E-17	3.07E-15	2.71E-15	1.21E-15	4.64E-16	1.36E-16		
$U(h)$	=	1 m/s			Kr-88	5.48E-05	3.29E-42	6.03E-17	4.71E-15	4.16E-15	1.86E-15	7.12E-16	2.08E-16		
X/Q	=	7.62E-05 s/m ³	=	7.6E-11 s/cm ³	Xe-133m	2.84E-06	1.71E-43	3.13E-18	2.45E-16	2.16E-16	9.67E-17	3.70E-17	1.08E-17		
					Xe-133	1.02E-04	6.11E-42	1.12E-16	8.76E-15	7.74E-15	3.46E-15	1.32E-15	3.87E-16		
					Xe-135m	1.58E-05	9.48E-43	1.74E-17	1.36E-15	1.20E-15	5.37E-16	2.05E-16	6.00E-17		
					Xe-135	1.01E-04	6.07E-42	1.11E-16	8.70E-15	7.69E-15	3.44E-15	1.31E-15	3.84E-16		
Calculated Maximum Concentration Point $2\sigma(z)^2 = h(e)^2$				Paquill D X/Q (s / cc)	50 m X/Q (s / cc)	200 m X/Q (s / cc)	500 m X/Q (s / cc)	1000 m X/Q (s / cc)	2000 m X/Q (s / cc)	5000 m X/Q (s / cc)	10000 m X/Q (s / cc)				
$h(e)^2$	=	1228.643 m ²			$\sigma(y)$	4	16	40	72	145	250	550			
$\sigma(z)^2$	=	614.3214 m ²			$\sigma(z)$	3	9	20	33	50	90	150			
$\sigma(z)$	=	25 m			X/Q	6.00E-38	1.1E-12	8.6E-11	7.6E-11	3.4E-11	1.3E-11	3.80E-12			
$X[\sigma(z)=25]$	=	700 m													
Linear Extrapolation Data for X/Q at 50 m				Stack RAM Release Rate (Ci / s)	200 m Concentration (Ci / cc)	300 m Concentration (Ci / cc)	400 m Concentration (Ci / cc)	500 m Concentration (Ci / cc)	600 m Concentration (Ci / cc)	700 m Concentration (Ci / cc)	800 m Concentration (Ci / cc)	900 m Concentration (Ci / cc)	1000 m Concentration (Ci / cc)		
$\sigma(y)$					I-131	9.08E-08	9.99E-20	3.63E-18	5.09E-18	7.81E-18	7.90E-18	8.35E-18	7.90E-18	7.45E-18	6.90E-18
x_1	=	100 m			I-132	1.35E-07	1.49E-19	5.42E-18	7.58E-18	1.16E-17	1.18E-17	1.25E-17	1.18E-17	1.11E-17	1.03E-17
x_2	=	200 m			I-133	2.22E-07	2.44E-19	8.86E-18	1.24E-17	1.91E-17	1.93E-17	2.04E-17	1.93E-17	1.82E-17	1.68E-17
$\sigma(y_1)$	=	8 m			I-134	2.35E-07	2.59E-19	9.42E-18	1.32E-17	2.02E-17	2.05E-17	2.17E-17	2.05E-17	1.93E-17	1.79E-17
$\sigma(y_2)$	=	16 m			I-135	2.09E-07	2.30E-19	8.38E-18	1.17E-17	1.80E-17	1.82E-17	1.93E-17	1.82E-17	1.72E-17	1.59E-17
m	=	0.08			Kr-85m	2.00E-05	2.20E-17	8.01E-16	1.12E-15	1.72E-15	1.74E-15	1.84E-15	1.74E-15	1.64E-15	1.52E-15
b	=	0			Kr-85	4.29E-06	4.72E-18	1.72E-16	2.40E-16	3.69E-16	3.73E-16	3.95E-16	3.73E-16	3.52E-16	3.26E-16
$x(50 m)$	=	4			Kr-87	3.57E-05	3.92E-17	1.43E-15	2.00E-15	3.07E-15	3.10E-15	3.28E-15	3.10E-15	2.92E-15	2.71E-15
$\sigma(z)$					Kr-88	5.48E-05	6.03E-17	2.19E-15	3.07E-15	4.71E-15	4.77E-15	5.04E-15	4.77E-15	4.49E-15	4.16E-15
x_1	=	100 m			Xe-133m	2.84E-06	3.13E-18	1.14E-16	1.59E-16	2.45E-16	2.47E-16	2.62E-16	2.47E-16	2.33E-16	2.16E-16
x_2	=	200 m			Xe-133	1.02E-04	1.12E-16	4.08E-15	5.71E-15	8.76E-15	8.86E-15	9.37E-15	8.86E-15	8.35E-15	7.74E-15
$\sigma(z_1)$	=	5 m			Xe-135m	1.58E-05	1.74E-17	6.32E-16	8.85E-16	1.36E-15	1.37E-15	1.45E-15	1.37E-15	1.30E-15	1.20E-15
$\sigma(z_2)$	=	9 m			Xe-135	1.01E-04	1.11E-16	4.04E-15	5.66E-15	8.70E-15	8.80E-15	9.30E-15	8.80E-15	8.29E-15	7.69E-15
m	=	0.04													
b	=	1													
$x(50 m)$	=	3													
Pasquill D				200 m X/Q (s / cc)	300 m X/Q (s / cc)	400 m X/Q (s / cc)	500 m X/Q (s / cc)	600 m X/Q (s / cc)	700 m X/Q (s / cc)	800 m X/Q (s / cc)	900 m X/Q (s / cc)	1000 m X/Q (s / cc)			
$\sigma(y)$					$\sigma(y)$	16	25	32	40	47	52	60	65	72	
$\sigma(z)$					$\sigma(z)$	9	14	16	20	22	25	28	30	33	
X/Q					X/Q	1.1E-12	4.0E-11	5.6E-11	8.6E-11	8.7E-11	9.2E-11	8.7E-11	8.2E-11	7.6E-11	

J. Pasquill F Condition Results

Atmospheric Dispersion Calculator				Stack		Site Boundary		Nearest Residence		1000 m		2000 m		5000 m		10000 m								
				RAM Release Rate (Ci / s)	50 m Concentration (Ci / cc)	200 m Concentration (Ci / cc)	500 m Concentration (Ci / cc)	1000 m Concentration (Ci / cc)	2000 m Concentration (Ci / cc)	5000 m Concentration (Ci / cc)	10000 m Concentration (Ci / cc)													
π	=	3.141592654		I-131	9.08E-08	5.45E-119	1.91E-32	3.45E-20	3.18E-18	5.27E-18	3.09E-18	1.63E-18												
$h(s)$	=	115 ft	= 35.052 m	I-132	1.35E-07	8.12E-119	2.84E-32	5.14E-20	4.74E-18	7.85E-18	4.60E-18	2.44E-18												
$h(t)$	=	0 ft	= 0 m	I-133	2.22E-07	1.33E-118	4.65E-32	8.42E-20	7.76E-18	1.29E-17	7.53E-18	3.99E-18												
$h(e)$	=	115 ft	= 35.052 m	I-134	2.35E-07	1.41E-118	4.94E-32	8.94E-20	8.24E-18	1.37E-17	8.00E-18	4.24E-18												
$h(e)^2$	=		= 1228.643 m ²	I-135	2.09E-07	1.26E-118	4.40E-32	7.96E-20	7.33E-18	1.21E-17	7.12E-18	3.77E-18												
$\sigma(y)$	=	160 m		Kr-85m	2.00E-05	1.20E-116	4.20E-30	7.61E-18	7.00E-16	1.16E-15	6.80E-16	3.60E-16												
$\sigma(z)$	=	35 m		Kr-85	4.29E-06	2.57E-117	9.01E-31	1.63E-18	1.50E-16	2.49E-16	1.46E-16	7.72E-17												
$\sigma(z)^2$	=	1225 m ²		Kr-87	3.57E-05	2.14E-116	7.49E-30	1.36E-17	1.25E-15	2.07E-15	1.21E-15	6.42E-16												
$U(h)$	=	1 m/s		Kr-88	5.48E-05	3.29E-116	1.15E-29	2.08E-17	1.92E-15	3.18E-15	1.86E-15	9.86E-16												
χ/Q	=	3.44246E-05 s/m ³	= 3.4E-11 s/cm ³	Xe-133m	2.84E-06	1.71E-117	5.97E-31	1.08E-18	9.95E-17	1.65E-16	9.67E-17	5.12E-17												
				Xe-133	1.02E-04	6.11E-116	2.14E-29	3.87E-17	3.57E-15	5.91E-15	3.46E-15	1.83E-15												
				Xe-135m	1.58E-05	9.48E-117	3.32E-30	6.00E-18	5.53E-16	9.16E-16	5.37E-16	2.84E-16												
				Xe-135	1.01E-04	6.07E-116	2.12E-29	3.84E-17	3.54E-15	5.87E-15	3.44E-15	1.82E-15												
Calculated Maximum Concentration Point $2\sigma(z)^2 = h(e)^2$				Paquill F		50 m X/Q (s / cc)	200 m X/Q (s / cc)	500 m X/Q (s / cc)	1000 m X/Q (s / cc)	2000 m X/Q (s / cc)	5000 m X/Q (s / cc)	10000 m X/Q (s / cc)												
$h(e)^2$	=	1228.642704 m ²		$\sigma(y)$		2	8	20	40	70	160	280												
$\sigma(z)^2$	=	614.321352 m ²		$\sigma(z)$		1.6	4	8.5	15	22	35	46												
$\sigma(z)$	=	25 m		X/Q		6.00E-112	2.1E-25	3.8E-13	3.5E-11	5.8E-11	3.4E-11	1.80E-11												
$x[\sigma(z)=25]$	=	2500 m																						
Linear Extrapolation Data for X/Q at 50 m				Stack		1000 m		1500 m		2000 m		2500 m		3000 m		3500 m		4000 m		4500 m		5000 m		
				RAM Release Rate (Ci / s)	Concentration (Ci / cc)	Concentration (Ci / cc)	Concentration (Ci / cc)	Concentration (Ci / cc)	Concentration (Ci / cc)	Concentration (Ci / cc)	Concentration (Ci / cc)	Concentration (Ci / cc)	Concentration (Ci / cc)	Concentration (Ci / cc)	Concentration (Ci / cc)	Concentration (Ci / cc)	Concentration (Ci / cc)	Concentration (Ci / cc)	Concentration (Ci / cc)	Concentration (Ci / cc)	Concentration (Ci / cc)	Concentration (Ci / cc)	Concentration (Ci / cc)	
$\sigma(y)$	=			I-131	9.08E-08	3.18E-18	4.09E-18	5.27E-18	5.45E-18	4.72E-18	4.09E-18	3.54E-18	3.36E-18	3.09E-18										
$x1$	=	100 m		I-132	1.35E-07	4.74E-18	6.09E-18	7.85E-18	8.12E-18	7.04E-18	6.09E-18	5.28E-18	5.01E-18	4.60E-18										
$x2$	=	200 m		I-133	2.22E-07	7.76E-18	9.97E-18	1.29E-17	1.33E-17	1.15E-17	9.97E-18	8.64E-18	8.20E-18	7.53E-18										
$\sigma(y1)$	=	4 m		I-134	2.35E-07	8.24E-18	1.06E-17	1.37E-17	1.41E-17	1.22E-17	1.06E-17	9.18E-18	8.71E-18	8.00E-18										
$\sigma(y2)$	=	8 m		I-135	2.09E-07	7.33E-18	9.43E-18	1.21E-17	1.26E-17	1.09E-17	9.43E-18	8.17E-18	7.75E-18	7.12E-18										
m	=	0.04		Kr-85m	2.00E-05	7.00E-16	9.01E-16	1.16E-15	1.20E-15	1.04E-15	9.01E-16	7.81E-16	7.41E-16	6.80E-16										
b	=	0		Kr-85	4.29E-06	1.50E-16	1.93E-16	2.49E-16	2.57E-16	2.23E-16	1.93E-16	1.67E-16	1.59E-16	1.46E-16										
$x(50 m)$	=	2		Kr-87	3.57E-05	1.25E-15	1.60E-15	2.07E-15	2.14E-15	1.85E-15	1.60E-15	1.39E-15	1.32E-15	1.21E-15										
				Kr-88	5.48E-05	1.92E-15	2.46E-15	3.18E-15	3.29E-15	2.85E-15	2.46E-15	2.14E-15	2.03E-15	1.86E-15										
				Xe-133m	2.84E-06	9.95E-17	1.28E-16	1.65E-16	1.71E-16	1.48E-16	1.28E-16	1.11E-16	1.05E-16	9.67E-17										
				Xe-133	1.02E-04	3.57E-15	4.58E-15	5.91E-15	6.11E-15	5.30E-15	4.58E-15	3.97E-15	3.77E-15	3.46E-15										
				Xe-135m	1.58E-05	5.53E-16	7.11E-16	9.16E-16	9.48E-16	8.22E-16	7.11E-16	6.16E-16	5.85E-16	5.37E-16										
				Xe-135	1.01E-04	3.54E-15	4.55E-15	5.87E-15	6.07E-15	5.26E-15	4.55E-15	3.94E-15	3.74E-15	3.44E-15										
Pasquill F				1000 m X/Q (s / cc)		1500 m X/Q (s / cc)		2000 m X/Q (s / cc)		2500 m X/Q (s / cc)		3000 m X/Q (s / cc)		3500 m X/Q (s / cc)		4000 m X/Q (s / cc)		4500 m X/Q (s / cc)		5000 m X/Q (s / cc)				
$\sigma(y)$	=	40		$\sigma(y)$		40	50	70	80	100	120	140	150	160										
$\sigma(z)$	=	15		$\sigma(z)$		15	17	22	25	28	30	32	34	35										
X/Q	=	3.5E-11		X/Q		3.5E-11	4.5E-11	5.8E-11	6.0E-11	5.2E-11	4.5E-11	3.9E-11	3.7E-11	3.4E-11										

K. Fumigation Example Calculation for Site Boundary Concentrations Under Pasquill F Conditions

1. NRC Regulatory Guide 1.145 section 1.3.2.b provides the dispersion equation for fumigation conditions, and indicates that:

A.
$$\frac{\chi}{Q} = \frac{1}{(2\pi)^{1/2} \sigma_y u_{he} h_e}$$

- B. A wind speed of $u = 2$ meters / second is considered to be conservative. Since the initial conservative assumption was made that the wind speed is $u = 1$ meter / second, and this is more conservative than an assumption of 2 meters / second, the analysis was done with $u = 1$ meter / second.

- C. The lateral dispersion coefficient σ_y is determined under air turbulent conditions of Pasquill F.

2. The Site Boundary distance from the stack is 50 meters.
3. The σ_y dispersion coefficient at 50 meters under Pasquill F conditions was found to be 2 meters.
4. Consequently, the values of each of the factors in the fumigation dispersion equation are:

$$h_e = 35.052 \text{ m}$$

$$u_{he} = 1 \text{ m / s}$$

$$\sigma_y = 2.0 \text{ m}$$

6. Plugging these values into the non-fumigation dispersion equation:

$$\begin{aligned} \frac{\chi}{Q} &= \frac{1}{(2\pi)^{1/2} \sigma_y u_{he} h_e} = \frac{1}{(2\pi)^{1/2} (2\text{m})(1\text{m/s})(35.052\text{m})} \\ &= 5.69 \times 10^{-3} \text{ s / m}^3 \end{aligned}$$

Converting the volume to units of cm^3 :

$$\frac{\chi}{Q} = (5.69 \times 10^{-3} \text{ s / m}^3)(\text{m / 100 cm})^3 = 5.69 \times 10^{-9} \text{ s / cm}^3$$

7. Using this to convert the stack release rate of I-131 into a concentration:

For I-131, the release rate out of the stack was $9.08 \times 10^{-8} \text{ Ci / s}$.

$$(9.08 \times 10^{-8} \text{ Ci / s})(5.69 \times 10^{-9} \text{ s / cm}^3) = 5.17 \times 10^{-16} \text{ Ci / cm}^3$$

This is the concentration of I-131 at ground level, at a distance of 50 meters down wind of the stack, if the air turbulence is in a fumigation condition, and the wind speed is 1 m / s.

L. Fumigation Results

Atmospheric Dispersion Calculator				Stack		Site Boundary		Nearest Residence								
				RAM Release Rate (Ci / s)	50 m Concentration (Ci / cc)	200 m Concentration (Ci / cc)	500 m Concentration (Ci / cc)	1000 m Concentration (Ci / cc)	2000 m Concentration (Ci / cc)	5000 m Concentration (Ci / cc)	10000 m Concentration (Ci / cc)					
π	=	3.141593		I-131	9.08E-08	5.18E-16	1.27E-16	5.18E-17	2.54E-17	1.45E-17	6.45E-18	3.72E-18				
2π	=	6.283185		I-132	1.35E-07	7.72E-16	1.90E-16	7.72E-17	3.79E-17	2.17E-17	9.61E-18	5.55E-18				
$(2\pi)^{1/2}$	=	2.506628		I-133	2.22E-07	1.26E-15	3.10E-16	1.26E-16	6.20E-17	3.55E-17	1.57E-17	9.09E-18				
$h(s)$	=	115 ft	= 35.052 m	I-134	2.35E-07	1.34E-15	3.30E-16	1.34E-16	6.59E-17	3.77E-17	1.67E-17	9.65E-18				
$h(t)$	=	0 ft	= 0 m	I-135	2.09E-07	1.19E-15	2.93E-16	1.19E-16	5.87E-17	3.35E-17	1.49E-17	8.59E-18				
$h(e)$	=	115 ft	= 35.052 m	Kr-85m	2.00E-05	1.14E-13	2.80E-14	1.14E-14	5.60E-15	3.20E-15	1.42E-15	8.21E-16				
$\sigma(y)$	=	6 m		Kr-85	4.29E-06	2.44E-14	6.00E-15	2.44E-15	1.20E-15	6.86E-16	3.04E-16	1.76E-16				
$U(h_e)$	=	1 m/s		Kr-87	3.57E-05	2.03E-13	4.99E-14	2.03E-14	9.99E-15	5.71E-15	2.53E-15	1.46E-15				
				Kr-88	5.48E-05	3.12E-13	7.67E-14	3.12E-14	1.53E-14	8.76E-15	3.89E-15	2.25E-15				
				Xe-133m	2.84E-06	1.62E-14	3.98E-15	1.62E-15	7.96E-16	4.55E-16	2.02E-16	1.17E-16				
				Xe-133	1.02E-04	5.81E-13	1.43E-13	5.81E-14	2.85E-14	1.63E-14	7.23E-15	4.18E-15				
				Xe-135m	1.58E-05	9.01E-14	2.21E-14	9.01E-15	4.42E-15	2.53E-15	1.12E-15	6.48E-16				
				Xe-135	1.01E-04	5.76E-13	1.42E-13	5.76E-14	2.83E-14	1.62E-14	7.18E-15	4.15E-15				
X/Q	=	1.90E-03 s/m ³	= 1.9E-09 s/cm ³													
Calculated Maximum Concentration Point $2\sigma(z)^2 = h(e)^2$																
$h(e)^2$	=		m ²	$\sigma(y)$	2	8	20	40	70	160	280					
$\sigma(z)^2$	=		m ²	X/Q	5.7E-09	1.4E-09	5.7E-10	2.8E-10	1.6E-10	7.1E-11	4.1E-11					
$\sigma(z)$	=		m													
$x[\sigma(z)=25]$	=		m													
Linear Extrapolation Data for X/Q at 50 m																
$\sigma(y)$																
x_1	=	100 m														
x_2	=	200 m														
$\sigma(y_1)$	=	4 m														
$\sigma(y_2)$	=	8 m														
m	=	0.04														
b	=	0														
$x(50 m)$	=	2														
$\sigma(z)$																
x_1	=	100 m														
x_2	=	200 m														
$\sigma(z_1)$	=	2.4 m														
$\sigma(z_2)$	=	4 m														
m	=	0.016														
b	=	0.8														
$x(50 m)$	=	1.6														

Paquet F		50 m X/Q (s / cc)	200 m X/Q (s / cc)	500 m X/Q (s / cc)	1000 m X/Q (s / cc)	2000 m X/Q (s / cc)	5000 m X/Q (s / cc)	10000 m X/Q (s / cc)
$\sigma(y)$		2	8	20	40	70	160	280
X/Q		5.7E-09	1.4E-09	5.7E-10	2.8E-10	1.6E-10	7.1E-11	4.1E-11

Stack RAM Release Rate (Ci / s)		50 m Concentration (Ci / cc)	100 m Concentration (Ci / cc)	150 m Concentration (Ci / cc)	200 m Concentration (Ci / cc)	250 m Concentration (Ci / cc)	300 m Concentration (Ci / cc)	350 m Concentration (Ci / cc)	400 m Concentration (Ci / cc)	500 m Concentration (Ci / cc)
I-131	9.08E-08	5.18E-16	2.54E-16	1.73E-16	1.27E-16	0.00E+00	0.00E+00	0.00E+00	0.00E+00	0.00E+00
I-132	1.35E-07	7.72E-16	3.79E-16	2.57E-16	1.90E-16	0.00E+00	0.00E+00	0.00E+00	0.00E+00	0.00E+00
I-133	2.22E-07	1.26E-15	6.20E-16	4.21E-16	3.10E-16	0.00E+00	0.00E+00	0.00E+00	0.00E+00	0.00E+00
I-134	2.35E-07	1.34E-15	6.59E-16	4.47E-16	3.30E-16	0.00E+00	0.00E+00	0.00E+00	0.00E+00	0.00E+00
I-135	2.09E-07	1.19E-15	5.87E-16	3.98E-16	2.93E-16	0.00E+00	0.00E+00	0.00E+00	0.00E+00	0.00E+00
Kr-85m	2.00E-05	1.14E-13	5.60E-14	3.80E-14	2.80E-14	0.00E+00	0.00E+00	0.00E+00	0.00E+00	0.00E+00
Kr-85	4.29E-06	2.44E-14	1.20E-14	8.15E-15	6.00E-15	0.00E+00	0.00E+00	0.00E+00	0.00E+00	0.00E+00
Kr-87	3.57E-05	2.03E-13	9.99E-14	6.78E-14	4.99E-14	0.00E+00	0.00E+00	0.00E+00	0.00E+00	0.00E+00
Kr-88	5.48E-05	3.12E-13	1.53E-13	1.04E-13	7.67E-14	0.00E+00	0.00E+00	0.00E+00	0.00E+00	0.00E+00
Xe-133m	2.84E-06	1.62E-14	7.96E-15	5.40E-15	3.98E-15	0.00E+00	0.00E+00	0.00E+00	0.00E+00	0.00E+00
Xe-133	1.02E-04	5.81E-13	2.85E-13	1.94E-13	1.43E-13	0.00E+00	0.00E+00	0.00E+00	0.00E+00	0.00E+00
Xe-135m	1.58E-05	9.01E-14	4.42E-14	3.00E-14	2.21E-14	0.00E+00	0.00E+00	0.00E+00	0.00E+00	0.00E+00
Xe-135	1.01E-04	5.76E-13	2.83E-13	1.92E-13	1.42E-13	0.00E+00	0.00E+00	0.00E+00	0.00E+00	0.00E+00

Pasquel F		50 m X/Q (s / cc)	100 m X/Q (s / cc)	150 m X/Q (s / cc)	200 m X/Q (s / cc)	250 m X/Q (s / cc)	300 m X/Q (s / cc)	350 m X/Q (s / cc)	400 m X/Q (s / cc)	500 m X/Q (s / cc)
$\sigma(y)$		2	4	6	8					
X/Q		5.7E-09	2.8E-09	1.9E-09	1.4E-09					

M. Results Summary

Site Boundary Concentration					Maximum Concentration Point				
Non-Fumigation Conditions				Fumigation	Non-Fumigation Conditions				Fumigation
Pasquill	Pasquill	Pasquill	Pasquill	Pasquill	Pasquill	Pasquill	Pasquill	Pasquill	Pasquill
B	D	F	F	B	D	F	F	B	F
50 m	50 m	50 m	50 m	200 m	500 m	2500 m	50 m	200 m	500 m
Concentration	Concentration	Concentration	Concentration	Concentration	Concentration	Concentration	Concentration	Concentration	Concentration
(Ci / cc)	(Ci / cc)	(Ci / cc)	(Ci / cc)	(Ci / cc)	(Ci / cc)	(Ci / cc)	(Ci / cc)	(Ci / cc)	(Ci / cc)
I-131	2.54E-20	5.45E-45	5.45E-119	5.18E-16	I-131	8.90E-18	7.81E-18	5.45E-18	5.18E-16
I-132	3.79E-20	8.12E-45	8.12E-119	7.72E-16	I-132	1.33E-17	1.16E-17	8.12E-18	7.72E-16
I-133	6.20E-20	1.33E-44	1.33E-118	1.26E-15	I-133	2.17E-17	1.91E-17	1.33E-17	1.26E-15
I-134	6.59E-20	1.41E-44	1.41E-118	1.34E-15	I-134	2.31E-17	2.02E-17	1.41E-17	1.34E-15
I-135	5.87E-20	1.26E-44	1.26E-118	1.19E-15	I-135	2.05E-17	1.80E-17	1.26E-17	1.19E-15
Kr-85m	5.60E-18	1.20E-42	1.20E-116	1.14E-13	Kr-85m	1.96E-15	1.72E-15	1.20E-15	1.14E-13
Kr-85	1.20E-18	2.57E-43	2.57E-117	2.44E-14	Kr-85	4.20E-16	3.69E-16	2.57E-16	2.44E-14
Kr-87	9.99E-18	2.14E-42	2.14E-116	2.03E-13	Kr-87	3.50E-15	3.07E-15	2.14E-15	2.03E-13
Kr-88	1.53E-17	3.29E-42	3.29E-116	3.12E-13	Kr-88	5.37E-15	4.71E-15	3.29E-15	3.12E-13
Xe-133m	7.96E-19	1.71E-43	1.71E-117	1.62E-14	Xe-133m	2.79E-16	2.45E-16	1.71E-16	1.62E-14
Xe-133	2.85E-17	6.11E-42	6.11E-116	5.81E-13	Xe-133	9.98E-15	8.76E-15	6.11E-15	5.81E-13
Xe-135m	4.42E-18	9.48E-43	9.48E-117	9.01E-14	Xe-135m	1.55E-15	1.36E-15	9.48E-16	9.01E-14
Xe-135	2.83E-17	6.07E-42	6.07E-116	5.76E-13	Xe-135	9.91E-15	8.70E-15	6.07E-15	5.76E-13

Nearest Residence Concentration				
Non-Fumigation Conditions				Fumigation
Pasquill	Pasquill	Pasquill	Pasquill	Pasquill
B	D	F	F	F
500 m	500 m	500 m	500 m	500 m
Concentration	Concentration	Concentration	Concentration	Concentration
(Ci / cc)	(Ci / cc)	(Ci / cc)	(Ci / cc)	(Ci / cc)
I-131	5.09E-18	7.81E-18	3.45E-20	5.18E-17
I-132	7.58E-18	1.16E-17	5.14E-20	7.72E-17
I-133	1.24E-17	1.91E-17	8.42E-20	1.26E-16
I-134	1.32E-17	2.02E-17	8.94E-20	1.34E-16
I-135	1.17E-17	1.80E-17	7.96E-20	1.19E-16
Kr-85m	1.12E-15	1.72E-15	7.61E-18	1.14E-14
Kr-85	2.40E-16	3.69E-16	1.63E-18	2.44E-15
Kr-87	2.00E-15	3.07E-15	1.36E-17	2.03E-14
Kr-88	3.07E-15	4.71E-15	2.08E-17	3.12E-14
Xe-133m	1.59E-16	2.45E-16	1.08E-18	1.62E-15
Xe-133	5.71E-15	8.76E-15	3.87E-17	5.81E-14
Xe-135m	8.85E-16	1.36E-15	6.00E-18	9.01E-15
Xe-135	5.66E-15	8.70E-15	3.84E-17	5.76E-14

1. A comparison of the data for non-fumigation Pasquill B, D, and F conditions, with the fumigation condition shows that in every case, the fumigation condition is the most conservative condition. Furthermore, under fumigation conditions, the maximum concentration point is the site boundary. Since the nearest residence is ten times the distance between the stack and the site boundary, the concentrations at the nearest residence are exactly one order of magnitude less than the concentrations at the site boundary.

N. RAM Concentrations at Points of Interest

RAM Concentrations at Points of Interest		
	Site Boundary and Maximum Concentration Point Concentration (Ci / cc)	Nearest Residence Concentration (Ci / cc)
I-131	5.18E-16	5.18E-17
I-132	7.72E-16	7.72E-17
I-133	1.26E-15	1.26E-16
I-134	1.34E-15	1.34E-16
I-135	1.19E-15	1.19E-16
Kr-85m	1.14E-13	1.14E-14
Kr-85	2.44E-14	2.44E-15
Kr-87	2.03E-13	2.03E-14
Kr-88	3.12E-13	3.12E-14
Xe-133m	1.62E-14	1.62E-15
Xe-133	5.81E-13	5.81E-14
Xe-135m	9.01E-14	9.01E-15
Xe-135	5.76E-13	5.76E-14

15. Dose Consequences

A. Dose Calculation Background Information

1. Health effects of radiation dose are separated into two categories:
 - A. Stochastic Effects – These effects are probabilistic, and are due to random ionization events. Consequently, there is no threshold for these effects, and the probability of occurrence is proportional to the dose received. Cancer is an example of these types of effects.
 - B. Non-Stochastic Effects – These effects depend on the amount of dose received beyond a minimum threshold, and the amount

of damage depends on the magnitude of the dose. Skin erythema is an example of a non-stochastic effect.

2. The objective of dose limits are to minimize the risk of stochastic effects, and to prevent the occurrence of non-stochastic effects. The dose limits have been designed to be independent of whether or not the radiation dose is uniform or non-uniform. This is achieved by having “effective dose” limits in which the “effective dose” takes into consideration the risk due to the irradiation of each individual organ and equates it to the risk associated with a uniform irradiation of the whole body.

B. Definitions

1. Allowable Limit on Intake (ALI) – This is the amount of RAM taken into the body via ingestion or inhalation that would lead to a committed effective dose equivalent of 5 Rem, or 50 Rem to any individual tissue or organ.
2. Derived Air Concentration (DAC) – This is the concentration of a given radionuclide in air which if inhaled at a rate of $2 \times 10^4 \text{ cm}^3$ per minute for one working year (2000 hours) would result in reaching the ALI.

Therefore, as an example, I-131 has a $\text{DAC} = 2 \times 10^{-8} \mu\text{Ci} / \text{cm}^3$ and an $\text{ALI} = 50 \mu\text{Ci}$ so the relationship between ALI and DAC is:

$$\text{ALI} = \left[\frac{2 \times 10^{-8} \mu\text{Ci}}{\text{cm}^3} \right] \left[\frac{2 \times 10^4 \text{ cm}^3}{\text{min}} \right] \left[\frac{60 \text{ min}}{\text{hr}} \right] \left[\frac{2000 \text{ hr}}{1} \right] = 48 \mu\text{Ci} \approx 50 \mu\text{Ci}$$

This means that if the reference man were to breathe in the DAC for 2000 hours, at a rate of $2 \times 10^4 \mu\text{Ci} / \text{minute}$, then they will have an uptake equivalent to the ALI.

3. Derived Air Concentration - Hour (DAC - Hour) – This is the product of the concentration of RAM in the air expressed as a fraction or multiple of the DAC, and the exposure time expressed in hours.
4. Absorbed Dose (D) – This is a measure of the radiation energy that is absorbed per unit mass of material of interest.
5. Dose Equivalent (H) – This is the product of the absorbed dose in tissue, quality factor (Q), and all other necessary modifying factors at the location of interest. The units of dose equivalent are the rem and sievert (Sv). In general:

$$H = DQ$$

6. Quality Factor (Q) – This is a regulatorally defined factor to account for the fact that the type and energy of the incident radiation has an effect on the amount of biological damage that is produced per unit of absorbed energy (absorbed dose).
7. Tissue Dose Equivalent (H_T) – This is the dose equivalent to a specific tissue or organ due to external sources.
8. Committed Dose Equivalent ($H_{T,50}$) – This is the dose equivalent to organs or tissues of reference (T) that will be received from a single intake of radioactive material by an individual that will be accumulated over the 50-year period following the intake.
9. Effective Dose Equivalent (H_E) – This equates the risk of a non-uniform external dose, or internal dose to the risk associated with a dose that is distributed uniformly over the whole body. A regulatorally defined weighting factor (W_T) is used for each organ, and the overall effective dose equivalent is:

$$H_E = \sum W_T H_T$$

This is the sum of the products of the dose equivalent to the organ or tissue (H_T) and the weighting factors (W_T) applicable to each of the body organs or tissues that are irradiated ($H_E = \sum W_T H_T$).

10. Committed Effective Dose Equivalent ($H_{E,50}$) – This is the effective dose equivalent accumulated over a 50 year period as a result of a single intake of radioactive material. In general:

$$H_{E,50} = \sum W_T H_{T,50}$$

This is the sum of the products of the weighting factors applicable to each of the body organs or tissues that are irradiated and the committed dose equivalent to these organs or tissues ($H_{E,50} = \sum W_T H_{T,50}$).

11. Deep Dose Equivalent (DDE) – This is the whole body dose at a depth of 1 cm due to an external exposure.
12. Total Effective Dose Equivalent (TEDE) – This is the sum of the DDE due to an external dose, and the CEDE due to an internal dose from an intake of radioactive material. In general:

$$TEDE = DDE + CEDE$$

C. Regulatory Limits^{10 CFR 20}

1. Occupational Dose Limits

- A. TEDE = 5 rem / yr [10 CFR 20.1201(a)(1)(i)]
- B. DDE + CDE to any individual organ or tissue = 50 rem / yr [10 CFR 20.1201(a)(1)(ii)]
- C. The DAC and ALI may be used to determine the individual's dose and to demonstrate compliance with dose limits. [10 CFR 20.1201(d)]
- D. If the only intake of radionuclides is by inhalation, the total effective dose equivalent limit is not exceeded if the sum of the deep-dose equivalent divided by the total effective dose equivalent limit, and one of the following, does not exceed unity [10 CFR 20.1202(b)]:
 - (1) The sum of the fractions of the inhalation ALI for each radionuclide, or
 - (2) The total number of derived air concentration-hours (DAC-hours) for all radionuclides divided by 2,000, or
 - (3) The sum of the calculated committed effective dose equivalents to all significantly irradiated¹ organs or tissues (T) calculated from bioassay data using appropriate biological models and expressed as a fraction of the annual limit.
- E. If the identity and concentration of each radionuclide in a mixture are known, the fraction of the DAC applicable to the mixture for use in calculating DAC-hours must be either [10 CFR 20.1204(e)]:
 - (1) The sum of the ratios of the concentration to the appropriate DAC value (e.g., D, W, Y) from appendix B to part 20 for each radionuclide in the mixture; or
 - (2) The ratio of the total concentration for all radionuclides in the mixture to the most restrictive DAC value for any radionuclide in the mixture.
- F. In order to calculate the committed effective dose equivalent, the licensee may assume that the inhalation of one ALI, or an exposure of 2,000 DAC-hours, results in a committed effective dose equivalent of 5 rems (0.05 Sv) for radionuclides that have their ALIs or DACs based on the committed effective dose equivalent. [10 CFR 20.1204(h)(1)]

- G. When the ALI (and the associated DAC) is determined by the nonstochastic organ dose limit of 50 rems (0.5 Sv), the intake of radionuclides that would result in a committed effective dose equivalent of 5 rems (0.05 Sv) (the stochastic ALI) is listed in parentheses in table 1 of appendix B to part 20. In this case, the licensee may, as a simplifying assumption, use the stochastic ALIs to determine committed effective dose equivalent. However, if the licensee uses the stochastic ALIs, the licensee must also demonstrate that the limit in § 20.1201(a)(1)(ii) is met. [10 CFR 20.1204(h)(2)]

2. Dose Limits for Individual Members of the Public

- A. TEDE = 100 mrem / yr [10 CFR 20.1301(a)(1)]
- B. A licensee shall show compliance with the annual dose limit in § 20.1301 by [10 CFR 20.1302(b)]:
 - (1) Demonstrating by measurement or calculation that the total effective dose equivalent to the individual likely to receive the highest dose from the licensed operation does not exceed the annual dose limit; or
 - (2) Demonstrating that:
 - (i) The annual average concentrations of radioactive material released in gaseous and liquid effluents at the boundary of the unrestricted area do not exceed the values specified in table 2 of appendix B to part 20; and
 - (ii) If an individual were continuously present in an unrestricted area, the dose from external sources would not exceed 0.002 rem (0.02 mSv) in an hour and 0.05 rem (0.5 mSv) in a year.

D. External Immersion Dose vs. Internal Dose

For the fuel failure accident we are concerned about the doses that individuals will receive due to airborne radioactive materials. The airborne RAM that is released in these types of accidents consist of halogens, such as iodine, and noble gases, such as xenon and krypton.

When halogens are inhaled, part of what is inhaled is taken up and incorporated into the body. Consequently, these isotopes cause not only an external immersion dose, but also a committed internal dose.

Noble gases are inert, so when they are inhaled, they are not taken up and incorporated into the body. Consequently, these isotopes only cause an external immersion dose and do not contribute to an internal dose.

During a fuel failure accident, the principle halogen that is released as an airborne RAM source is iodine. When iodine is uptaken into the body, it concentrates in the thyroid. As a result, the internal dose associated with a fuel failure accident would be the Committed Dose Equivalent ($H_{T,50}$) to the thyroid due to iodine.

During a fuel failure accident, the principle noble gases that are released as airborne RAM sources are krypton and xenon. These isotopes, in addition to the iodine isotopes are the sources for the external immersion dose. As a result, the external immersion dose that is associated with a fuel failure accident is the Deep Dose Equivalent (DDE) to the whole body due to the iodine, krypton, and xenon isotopes.

E. What We Must Show

1. Therefore, based on the regulations, we must show that:

A. The occupational doses to individuals inside confinement are no greater than:

1. TEDE = 5 rem
2. DDE + CDE to any individual organ or tissue = 50 rem / yr

B. The dose to the public at the site boundary is no greater than:

1. TEDE = 100 mrem / yr

F. Use of the DAC to Determine Deep Dose Equivalent (DDE)

The DAC for any given nuclide can be found in 10 CFR 20 Appendix B. For Kr-85, the inhalation value of the DAC for occupational exposure are given to be:

$$\text{DAC} = 1 \times 10^{-4} \mu\text{Ci} / \text{cm}^3$$

This means that if an individual is immersed in a concentration of $1 \times 10^{-4} \mu\text{Ci} / \text{cm}^3$ Kr-85 for 2000 hours, they would receive a DDE of 5 Rem whole body.

If an individual is immersed in an air concentration equivalent to one DAC, the average dose rate that they would be receiving would be:

Whole Body:

$$\left[\frac{5 \text{ rem}}{(2000 \text{ hr})} \right] = 2.5 \text{ mrem/hr}$$

Since this is the dose rate that is associated with an airborne RAM concentration of one DAC, we can relate the dose rate associated with being immersed in an airborne RAM concentration of one DAC by:

$$\left[\frac{2.5 \text{ mrem per hr}}{\text{DAC}} \right] = 2.5 \text{ mrem/DAC - hr}$$

We can express the concentration of any RAM in air as a fraction or multiple of the DAC:

$$\text{DAC Fraction (Multiple)} = (\text{Air Concentration}) / (\text{DAC})$$

Therefore, if we had a concentration of $6.06 \times 10^{-6} \mu\text{Ci} / \text{cm}^3$ of Kr-85 in the confinement air (the confinement concentration after 5 minutes), the DAC fraction (multiple) if the occupational DAC were $1 \times 10^{-4} \mu\text{Ci} / \text{cm}^3$ would be:

$$\begin{aligned} \text{DAC Fraction (Multiple)} &= (\text{Air Concentration}) / (\text{DAC}) \\ &= \left[\frac{6.06 \times 10^{-6} \mu\text{Ci}}{\text{cm}^3} \right] \left[\frac{\text{Kr - 85 DAC}}{1 \times 10^{-4} \mu\text{Ci/cm}^3} \right] \\ &= 6.06 \times 10^{-2} \text{ DAC} \end{aligned}$$

If we know the concentration of RAM in air as a fraction or multiple of the DAC, then we can determine the dose rate that that an individual immersed in the air would receive. Continuing with the Kr-85 example:

$$\left[\frac{2.5 \text{ mrem}}{\text{DAC - hr}} \right] \left[\frac{6.06 \times 10^{-2} \text{ DAC}}{1} \right] = 1.5 \times 10^{-1} \text{ mrem/hr}$$

For a mixture of airborne radionuclides, the total dose rate can be determined either by summing the individual DAC fractions and multiplying the sum by the dose rate per DAC - hr:

$$\left[\frac{2.5 \text{ mrem}}{\text{DAC - hr}} \right] \left[\frac{\sum \text{DAC Fractions}}{1} \right] = \text{Total Dose Rate (mrem/hr)}$$

Or by finding the dose rate associated with each nuclide and summing the individual dose rates to get the total dose rate:

$$\Sigma \left[\left(\frac{2.5 \text{ mrem}}{\text{DAC} - \text{hr}} \right) \left(\frac{\text{DAC Fraction}}{1} \right) \right] = \text{Total Dose Rate (mrem/hr)}$$

Consider:

1. Suppose that the air has a concentration of $6.06 \times 10^{-6} \mu\text{Ci} / \text{cm}^3$ of Kr-85, and $2.83 \times 10^{-5} \mu\text{Ci} / \text{cm}^3$ of Kr-85m in it. The DAC fractions are:

$$(\text{Air Concentration}) / (\text{DAC})$$

Where the DAC is defined in 10 CFR 20 for each isotope

2. For Kr-85 the DAC fraction has been previously calculated to be 6.06×10^{-2} DAC.
3. For Kr-85m, given that the DAC is $2 \times 10^{-5} \mu\text{Ci} / \text{cm}^3$, the DAC fraction is:

$$(2.83 \times 10^{-5} \mu\text{Ci} / \text{cm}^3) / (2 \times 10^{-5} \mu\text{Ci} / \text{cm}^3) = 1.42 \text{ DAC}$$

4. Therefore the total DAC fraction is:

$$\text{Total DAC Fraction} = 6.06 \times 10^{-2} \text{ DAC} + 1.42 \text{ DAC} = 1.48 \text{ DAC}$$

5. Therefore the deep dose equivalent is:

$$\left[\frac{2.5 \text{ mrem}}{\text{DAC} - \text{hr}} \right] \left[\frac{1.48 \text{ DAC}}{1} \right] = 3.7 \text{ mrem/hr}$$

- G. Deep Dose Equivalent to Personnel Inside Confinement for the First Five Minutes After Fuel

Facility evacuation drills show that in the event of an evacuation, the confinement building can be evacuated within 5 minutes. Using the confinement concentration after five minutes, and taking into consideration that individuals inside confinement will only be exposed for five minutes, the projected dose from the gas release for individuals inside confinement when the fuel failure occurs is:

$$\left[\frac{2.5 \text{ mrem}}{\text{DAC} - \text{hr}} \right] \left[\frac{\text{DAC Fraction}}{1} \right] \left[\frac{5 \text{ min}}{1} \right] \left[\frac{\text{hr}}{60 \text{ min}} \right] = \text{DDE (mrem)}$$

For the isotopes of interest:

Confinement Air Immersion Dose					
Nuclide	Confinement Concentration (microCi / cc)	Occupational DAC (microCi / cc)	DAC Fraction	Immersion DAC (DAC-hr)	Deep Dose Equivalent mrem
I-131	2.94E-07	2.00E-08	1.47E+01	1.23E+00	3.07E+00
I-132	4.39E-07	3.00E-06	1.46E-01	1.22E-02	3.05E-02
I-133	7.18E-07	1.00E-07	7.18E+00	5.99E-01	1.50E+00
I-134	7.63E-07	2.00E-05	3.82E-02	3.18E-03	7.95E-03
I-135	6.79E-07	7.00E-07	9.70E-01	8.08E-02	2.02E-01
Kr-85m	2.83E-05	2.00E-05	1.41E+00	1.18E-01	2.94E-01
Kr-85	6.06E-06	1.00E-04	6.06E-02	5.05E-03	1.26E-02
Kr-87	5.04E-05	5.00E-06	1.01E+01	8.40E-01	2.10E+00
Kr-88	7.74E-05	2.00E-06	3.87E+01	3.22E+00	8.06E+00
Xe-133m	4.02E-06	1.00E-04	4.02E-02	3.35E-03	8.37E-03
Xe-133	1.44E-04	1.00E-04	1.44E+00	1.20E-01	3.00E-01
Xe-135m	2.23E-05	9.00E-06	2.48E+00	2.07E-01	5.17E-01
Xe-135	1.43E-04	1.00E-05	1.43E+01	1.19E+00	2.98E+00

Therefore, if someone remains in confinement for five minutes, they will receive a deep dose equivalent of:

$$\sum \text{Individual DDE} = 19.1 \text{ mrem}$$

G. Deep Dose Equivalent to General Public at the Site Boundary

Section 1.3 of NRC Regulatory Guide 1.145 (November 1982 Rev. 1) indicates that a conservative estimation of site boundary doses can be determined by it assuming that an individual spends two hours at the site boundary immediately following an accident. The deep dose equivalent would be the sum of the dose equivalents from each of the isotopes of interest.

For the isotopes of interest:

Site Boundary Air Immersion Dose						
Nuclide	Site Boundary Concentration (Ci / cc)	Site Boundary Concentration (microCi / cc)	Occupational DAC (microCi / cc)	DAC Fraction	Immersion DAC (DAC-hr)	Deep Dose Equivalent mrem
I-131	5.18E-16	5.18E-10	2.00E-08	2.59E-02	5.18E-02	1.29E-01
I-132	7.72E-16	7.72E-10	3.00E-06	2.57E-04	5.14E-04	1.29E-03
I-133	1.26E-15	1.26E-09	1.00E-07	1.26E-02	2.53E-02	6.32E-02
I-134	1.34E-15	1.34E-09	2.00E-05	6.71E-05	1.34E-04	3.35E-04
I-135	1.19E-15	1.19E-09	7.00E-07	1.71E-03	3.41E-03	8.53E-03
Kr-85m	1.14E-13	1.14E-07	2.00E-05	5.70E-03	1.14E-02	2.85E-02
Kr-85	2.44E-14	2.44E-08	1.00E-04	2.44E-04	4.89E-04	1.22E-03
Kr-87	2.03E-13	2.03E-07	5.00E-06	4.07E-02	8.13E-02	2.03E-01
Kr-88	3.12E-13	3.12E-07	2.00E-06	1.56E-01	3.12E-01	7.81E-01
Xe-133m	1.62E-14	1.62E-08	1.00E-04	1.62E-04	3.24E-04	8.11E-04
Xe-133	5.81E-13	5.81E-07	1.00E-04	5.81E-03	1.16E-02	2.90E-02
Xe-135m	9.01E-14	9.01E-08	9.00E-06	1.00E-02	2.00E-02	5.00E-02
Xe-135	5.76E-13	5.76E-07	1.00E-05	5.76E-02	1.15E-01	2.88E-01

Therefore, if a member of the general public remains at the site boundary for two hours, they will receive a dose of:

$$\sum \text{Individual DDE} = 1.58 \text{ mrem}$$

H. Deep Dose Equivalent to General Public at the Nearest Residence

Again, assuming a two hour occupancy time, the deep dose equivalent at the nearest residency is:

Nearest Residence Air Immersion Dose						
Nuclide	Nearest Residence Concentration (Ci / cc)	Nearest Residence Concentration (microCi / cc)	Occupational DAC (microCi / cc)	DAC Fraction	Immersion DAC (DAC-hr)	Deep Dose Equivalent mrem
I-131	5.18E-17	5.18E-11	2.00E-08	2.59E-03	5.18E-03	1.29E-02
I-132	7.72E-17	7.72E-11	3.00E-06	2.57E-05	5.14E-05	1.29E-04
I-133	1.26E-16	1.26E-10	1.00E-07	1.26E-03	2.53E-03	6.32E-03
I-134	1.34E-16	1.34E-10	2.00E-05	6.71E-06	1.34E-05	3.35E-05
I-135	1.19E-16	1.19E-10	7.00E-07	1.71E-04	3.41E-04	8.53E-04
Kr-85m	1.14E-14	1.14E-08	2.00E-05	5.70E-04	1.14E-03	2.85E-03
Kr-85	2.44E-15	2.44E-09	1.00E-04	2.44E-05	4.89E-05	1.22E-04
Kr-87	2.03E-14	2.03E-08	5.00E-06	4.07E-03	8.13E-03	2.03E-02
Kr-88	3.12E-14	3.12E-08	2.00E-06	1.56E-02	3.12E-02	7.81E-02
Xe-133m	1.62E-15	1.62E-09	1.00E-04	1.62E-05	3.24E-05	8.11E-05
Xe-133	5.81E-14	5.81E-08	1.00E-04	5.81E-04	1.16E-03	2.90E-03
Xe-135m	9.01E-15	9.01E-09	9.00E-06	1.00E-03	2.00E-03	5.00E-03
Xe-135	5.76E-14	5.76E-08	1.00E-05	5.76E-03	1.15E-02	2.88E-02

Therefore, if a member of the general public remains at the nearest residence for two hours, they will receive a dose of:

$$\sum \text{Individual DDE} = 1.58 \times 10^{-1} \text{ mrem}$$

I. Use of the DAC to Determine the Committed Dose Equivalent to the Thyroid (CDE)

The ALI and DAC for any given nuclide can be found in 10 CFR 20 Appendix B. For I-131, the inhalation values for occupational exposure are given to be:

1. $ALI = 50 \mu\text{Ci}$

This means that an intake of 50 μCi of I-131 will lead to a CEDE of 5 Rem, or 50 Rem to any individual tissue or organ. Since iodine concentrates in the thyroid, the ALI is based on a dose of 50 Rem to the thyroid.

2. $DAC = 2 \times 10^{-8} \mu\text{Ci} / \text{cm}^3$

This means that if an individual inhales concentration of $2 \times 10^{-8} \mu\text{Ci} / \text{cm}^3$ I-131 at a rate of $2 \times 10^4 \text{ cm}^3$ per minute for 2000 hours, they would intake enough of the radionuclide to receive a CEDE of 5 Rem whole body, or 50 Rem to any individual tissue or organ:

If an individual is immersed in an air concentration equivalent to one DAC, the average dose rate that they would be receiving would be:

1. Individual Tissue or Organ (in this case Thyroid):

$$\left[\frac{50 \text{ rem}}{2000 \text{ hr}} \right] = 25 \text{ mrem} / \text{DAC} - \text{hr}$$

Since this is the dose rate that is associated with an airborne RAM concentration of one DAC, we can relate the dose rate associated with being immersed in an airborne RAM concentration of one DAC by:

$$\left[\frac{25 \text{ mrem per hr}}{\text{DAC}} \right] = 25 \text{ mrem} / \text{DAC} - \text{hr}$$

We can express the concentration of any RAM in air as a fraction or multiple of the DAC:

$$\text{DAC Fraction (Multiple)} = (\text{Air Concentration}) / (\text{DAC})$$

Therefore, if we had a concentration of $2.94 \times 10^{-7} \mu\text{Ci} / \text{cm}^3$ of I-131 in the confinement air, the DAC fraction (multiple) if the occupational DAC were $2 \times 10^{-8} \mu\text{Ci} / \text{cm}^3$ would be:

DAC Fraction (Multiple) = (Air Concentration) / (DAC)

$$= \left[\frac{2.94 \times 10^{-7} \mu\text{Ci}}{\text{cm}^3} \right] \left[\frac{I - 131 \text{ DAC}}{2 \times 10^{-8} \mu\text{Ci}/\text{cm}^3} \right]$$

$$= 14.7 \text{ DAC}$$

If we know the concentration of RAM in air as a fraction or multiple of the DAC, then we can determine the committed dose rate that that an individual immersed in the air would receive. Continuing with the I-131 example:

$$\left[\frac{25 \text{ mrem}}{\text{DAC} - \text{hr}} \right] \left[\frac{14.7 \text{ DAC}}{1} \right] = 367.5 \text{ mrem/hr}$$

If there is more than one nuclide in the air with the same dose rate associated with exposure (either whole body or individual organ), then the DAC fractions can be added together before determining the dose rate. Consider:

1. Suppose that the air has a concentration of $2.94 \times 10^{-7} \mu\text{Ci} / \text{cm}^3$ of I-131, and $4.39 \times 10^{-7} \mu\text{Ci} / \text{cm}^3$ of I-132 in it. The DAC fractions are:

$$(\text{Air Concentration}) / (\text{DAC})$$

Where the DAC is defined in 10 CFR 20 for each isotope

2. For I-131 the DAC fraction has been previously calculated to be 14.7 DAC.
3. For I-132, given that the DAC is $3 \times 10^{-6} \mu\text{Ci} / \text{cm}^3$, the DAC fraction is:

$$(4.39 \times 10^{-7} \mu\text{Ci} / \text{cm}^3) / (3 \times 10^{-6} \mu\text{Ci} / \text{cm}^3) = 1.46 \times 10^{-1} \text{ DAC}$$

4. Therefore the total DAC fraction is:

$$\text{Total DAC Fraction} = 14.7 \text{ DAC} + 1.46 \times 10^{-1} \text{ DAC} = 14.8 \text{ DAC}$$

5. For the iodines, the committed dose to the thyroid is also dependent on the amount of time that the individual is immersed. If an individual were only in the concentration of iodine for 5 minutes (0.083 hr), then the DAC fraction can be reduced:

$$\text{Immersion DAC} = (\text{DAC})(\text{Immersion Time})$$

$$\text{Immersion DAC} = (14.8 \text{ DAC})(0.083 \text{ hr}) = 1.23 \text{ DAC} - \text{hr}$$

6. Both of these DACs are based on a committed thyroid dose of 50 rem per year, which means that the dose rate associated with an air concentration of one DAC is 25 mrem / DAC - hr.
7. Therefore the committed dose to the thyroid for an individual that is immersed for 5 minutes in air with a concentration of $2.94 \times 10^{-7} \mu\text{Ci} / \text{cm}^3$ of I-131 and $4.39 \times 10^{-7} \mu\text{Ci} / \text{cm}^3$ of I-132 would be:

$$\left[\frac{25 \text{ mrem}}{\text{DAC} - \text{hr}} \right] \left[\frac{1.23 \text{ DAC} - \text{hr}}{1} \right] = 31 \text{ mrem}$$

J. Confinement Committed Dose to the Thyroid (CDE)

Halogens are an inhalation hazard because they are absorbed into the body. The halogen of interest in the case of a fuel failure is iodine. Iodine concentrates in the thyroid. Consequently, the DAC for each isotope of Iodine is based on the amount of isotope that will result in a 50 rem dose to the thyroid over a 2000 hour year. We have calculated that an individual immersed in air with a concentration of RAM in it equivalent to one DAC would lead to an internal dose rate of 25 mrem / hr to the thyroid.

Facility evacuation drills show that in the event of an evacuation, the confinement building can be evacuated within 5 minutes. Therefore the projected dose from the gas release for individuals inside confinement when the fuel failure occurs is:

$$\left[\frac{25 \text{ mrem}}{\text{DAC} - \text{hr}} \right] \left[\frac{\text{DAC Fraction}}{1} \right] \left[\frac{5 \text{ min}}{1} \right] \left[\frac{\text{hr}}{60 \text{ min}} \right] = \text{CDE} (\text{mrem})$$

For the isotopes of interest:

Confinement Internal Dose					
Nuclide	Confinement Concentration (microCi / cc)	Occupational DAC (microCi / cc)	DAC Fraction	Immersion DAC (DAC-hr)	Committed Dose Equivalent (mrem)
I-131	2.94E-07	2.00E-08	1.47E+01	1.23E+00	3.07E+01
I-132	4.39E-07	3.00E-06	1.46E-01	1.22E-02	3.05E-01
I-133	7.18E-07	1.00E-07	7.18E+00	5.99E-01	1.50E+01
I-134	7.63E-07	2.00E-05	3.82E-02	3.18E-03	7.95E-02
I-135	6.79E-07	7.00E-07	9.70E-01	8.08E-02	2.02E+00

Therefore, if someone remains in confinement for five minutes, they will receive a committed dose to the thyroid of:

$$\sum \text{Individual CDE} = 48 \text{ mrem}$$

K. Site Boundary Committed Dose to the Thyroid (CDE)

Section 1.3 of NRC Regulatory Guide 1.145 (November 1982 Rev. 1) indicates that a conservative estimation of site boundary doses can be determined by it assuming that an individual spends two hours at the site boundary immediately following an accident. The deep dose equivalent would be the sum of the dose equivalents from each of the isotopes of interest.

For the isotopes of interest:

Site Boundary Internal Dose					
Nuclide	Confinement Concentration (microCi / cc)	Occupational DAC (microCi / cc)	DAC Fraction	Immersion DAC (DAC-hr)	Committed Dose Equivalent (mrem)
I-131	5.18E-10	2.00E-08	2.59E-02	5.18E-02	1.29E+00
I-132	7.72E-10	3.00E-06	2.57E-04	5.14E-04	1.29E-02
I-133	1.26E-09	1.00E-07	1.26E-02	2.53E-02	6.32E-01
I-134	1.34E-09	2.00E-05	6.71E-05	1.34E-04	3.35E-03
I-135	1.19E-09	7.00E-07	1.71E-03	3.41E-03	8.53E-02

Therefore, if someone remains at the site boundary for two hours, they will receive a committed dose to the thyroid of:

$$\sum \text{Individual CDE} = 2.03 \text{ mrem}$$

L. Nearest Residence Committed Dose to the Thyroid (CDE)

Again, assuming a two hour occupancy time, the committed dose equivalent to the thyroid at the nearest residency is:

Nearest Residence Internal Dose					
Nuclide	Confinement Concentration (microCi / cc)	Occupational DAC (microCi / cc)	DAC Fraction	Immersion DAC (DAC-hr)	Committed Dose Equivalent (mrem)
I-131	5.18E-11	2.00E-08	2.59E-03	5.18E-03	1.29E-01
I-132	7.72E-11	3.00E-06	2.57E-05	5.14E-05	1.29E-03
I-133	1.26E-10	1.00E-07	1.26E-03	2.53E-03	6.32E-02
I-134	1.34E-10	2.00E-05	6.71E-06	1.34E-05	3.35E-04
I-135	1.19E-10	7.00E-07	1.71E-04	3.41E-04	8.53E-03

Therefore, if someone remains at the nearest residence for two hours, they will receive a committed dose to the thyroid of:

$$\sum \text{Individual CDE} = 2.03 \times 10^{-1} \text{ mrem}$$

M. Determination of the Committed Effective Dose Equivalent (CEDE)

The committed dose equivalent (CDE) is the cumulative dose that an individual organ in the body would receive due to the uptake of a radioisotope, over a 50 year period. An effective dose equivalent (H_E) uses a tissue weighting factor (W_T) to equate the risk associated with a non-uniform dose, to the risk associated with a uniformly distributed whole body dose. If the weighting factor is applied to the CDE, then we get the committed effective dose equivalent (CEDE), which provides a measure of what the risk associated with the dose to the individual organ would be if it were evenly distributed in the whole body:

$$\text{CEDE} = (W_T)(\text{CDE})$$

10 CFR 20.2003 Defines the weighting factor (W_T) for the thyroid to be:

$$W_{\text{Thyroid}} = 0.03$$

N. Confinement Committed Effective Dose Equivalent (CEDE)

The committed dose equivalent (CDE) for an individual that is in confinement for five minutes was found to be 48 mrem. Consequently, the CEDE for this individual is:

$$\text{CEDE} = (48 \text{ mrem})(0.03) = 1.44 \text{ mrem}$$

O. Site boundary Committed Effective Dose Equivalent (CEDE)

The committed dose equivalent (CDE) for an individual that is at the site boundary for two hours was found to be 2.03 mrem. Consequently, the CEDE for this individual is:

$$\text{CEDE} = (2.03 \text{ mrem})(0.03) = 6.09 \times 10^{-2} \text{ mrem}$$

P. Nearest Residence Committed Effective Dose Equivalent (CEDE)

The committed dose equivalent (CDE) for an individual that is at the nearest residence for two hours was found to be 2.03×10^{-1} mrem. Consequently, the CEDE for this individual is:

$$\text{CEDE} = (2.03 \times 10^{-1} \text{ mrem})(0.03) = 6.09 \times 10^{-3} \text{ mrem}$$

Q. Determination of the Total Effective Dose Equivalent (TEDE)

The total effective dose equivalent (TEDE) is the sum of the dose due to external sources (DDE) and internal sources (CEDE):

$$\text{TEDE} = \text{DDE} + \text{CEDE}$$

R. Confinement Total Effective Dose Equivalent (TEDE)

$$\text{TEDE} = 19.1 \text{ mrem} + 1.44 \text{ mrem} = 20.5 \text{ mrem}$$

S. Site Boundary Total Effective Dose Equivalent (TEDE)

$$\text{TEDE} = 1.58 \text{ mrem} + 6.09 \times 10^{-2} \text{ mrem} = 1.64 \text{ mrem}$$

T. Nearest Residence Total Effective Dose Equivalent (TEDE)

$$\text{TEDE} = 1.58 \times 10^{-1} \text{ mrem} + 6.09 \times 10^{-3} \text{ mrem} = 1.64 \times 10^{-1} \text{ mrem}$$

16. Conclusion

10 CFR 20 provides radiation dose limits to radiation workers, and to the general public. For radiation worker, the limits are:

50 rem / yr to an individual organ (CDE)

5 rem / yr whole body (TEDE)

For members of the general public, the limits are:

100 mrem / yr

The doses that an individual is predicted to receive due to a fuel failure event in which the core has reached saturation activity is based on the following assumptions:

- A. Individuals inside confinement recognize the problem and evacuate within five minutes.
- B. Individuals that are exposed outside confinement remain at the site boundary for two hours.
- C. Individuals that are exposed outside confinement remain at the nearest residence for two hours.

In all cases, the predicted doses are well below the regulatory limit. A summary of the predicted doses, and any regulatory limit associated with the dose is:

Dose Summary		Dose Limits	
Confinement Dose		Occupational Limits	General Public Limits
Committed Dose to Thyroid	4.80E+01 mrem	50 rem / yr	
CEDE	1.44E+00 mrem		
Immersion	1.91E+01 mrem		
TEDE	2.05E+01 mrem	5 rem / yr	100 mrem / yr
Site Boundary Dose			
Committed Dose to Thyroid	2.03E+00 mrem	50 rem / yr	
CEDE	6.08E-02 mrem		
Immersion	1.58E+00 mrem		
TEDE	1.65E+00 mrem	5 rem / yr	100 mrem / yr
Nearest Residence Dose			
Committed Dose to Thyroid	2.03E-01 mrem		
CEDE	6.08E-03 mrem		
Immersion	1.58E-01 mrem		
TEDE	1.65E-01 mrem		100 mrem / yr

References

1. Olson, Arne P., *Rhode Island Nuclear Science Center Transient Analyses*, ANL, Revised Jan. 20, 2016, Page 4.
2. Feldman, Earl E., *Loss of Coolant Accident (LOCA) of Safety Analysis Report of the Rhode Island Nuclear Science Center Reactor*, August 2010, Page 30.
3. NUREG 1465 *Accident Source Terms for Light Water Nuclear Power Plants*, USNRC, 1995, Page 2.
4. NUREG 1465 *Accident Source Terms for Light Water Nuclear Power Plants*, USNRC, 1995, Section 3.2, Page 9.
5. Regulatory Guide 1.183 *Alternative Radiological Source Terms for Evaluating Design Basis Accidents at Nuclear Power Reactors*, USNRC, July 2000, Section 3.4, Table 5, Page 15.
6. Regulatory Guide 1.183 *Alternative Radiological Source Terms for Evaluating Design Basis Accidents at Nuclear Power Reactors*, USNRC, July 2000, Section 3.2, Table 1, Page 13.
7. Regulatory Guide 1.183 *Alternative Radiological Source Terms for Evaluating Design Basis Accidents at Nuclear Power Reactors*, USNRC, July 2000, Section 3.5, Page 15.
8. Regulatory Guide 1.183 *Alternative Radiological Source Terms for Evaluating Design Basis Accidents at Nuclear Power Reactors*, USNRC, July 2000, Appendix B, Section 1.3, Page B-1.
9. *Rhode Island Nuclear Science Center Technical Specifications*, February 26, 2016, Specifications 2.2.1.2 and 2.2.2.2, Pages 12 and 14.
10. Regulatory Guide 1.183 *Alternative Radiological Source Terms for Evaluating Design Basis Accidents at Nuclear Power Reactors*, USNRC, July 2000, Appendix B, Section 2, Page B-2.
11. Regulatory Guide 1.183 *Alternative Radiological Source Terms for Evaluating Design Basis Accidents at Nuclear Power Reactors*, USNRC, July 2000, Appendix B, Section 3, Page B-1.
12. Regulatory Guide 1.183 *Alternative Radiological Source Terms for Evaluating Design Basis Accidents at Nuclear Power Reactors*, USNRC, July 2000, Section 3.3, Pages 13 and 14.

13. *Steady-State Thermal-Hydraulic Analysis for Forced-Convective Flow in the Rhode Island Nuclear Science Center (RINSC) Reactor*, Memo to James E. Matos from Earl E. Feldman, Dated September 3, 2010, Section 4.6.8, Page 21.
14. Regulatory Guide 1.183 *Alternative Radiological Source Terms for Evaluating Design Basis Accidents at Nuclear Power Reactors*, USNRC, July 2000, Appendix B Section 3, Page B-2.
15. Lamarsh, John R., *Introduction to Nuclear Engineering*, Addison-Wesley Publishing Company, 1977, Page 535.
16. NUREG / CR-2079 PNL-3691 *Analysis of Credible Accidents for Argonaut Reactors*, USNRC, 1981, Pages 46 -47.
17. EG&G Drawing Number 422873 *Rhode Island Nuclear Science Center Test Research Training Reactor Fuel Plate*.