

TVA	WALL THICKNESS PROFILE SHEET	REPORT NO: <i>R.P2466</i>
-----	---------------------------------	------------------------------

PROJECT: <u>WBN</u>	WELD NO: <u>SIF-D197-11</u>
UNIT: <u>2</u>	SYSTEM: <u>SIS</u>

Record Thickness Measurements As Indicated, Including Weld Width, Edge-To-Edge At 0°

Position	0°	90°	180°	270°
1	.686	.667	.743	.76
2	.72	.778	.768	.756
3	.88	.822	.835	.842
4	1.0	.98	1.0	.97
5	*	*	*	*

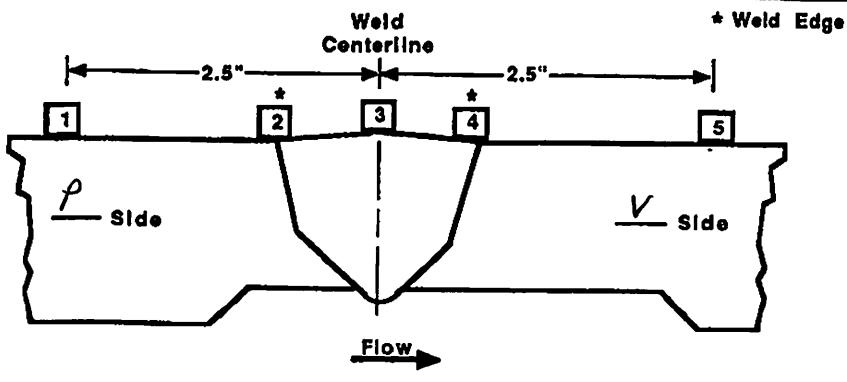

CROWN HEIGHT: <u>FLUSH</u>	DIAMETER: <u>6.0</u>
CROWN WIDTH: <u>.75</u>	WELD LENGTH: <u>21.0</u>

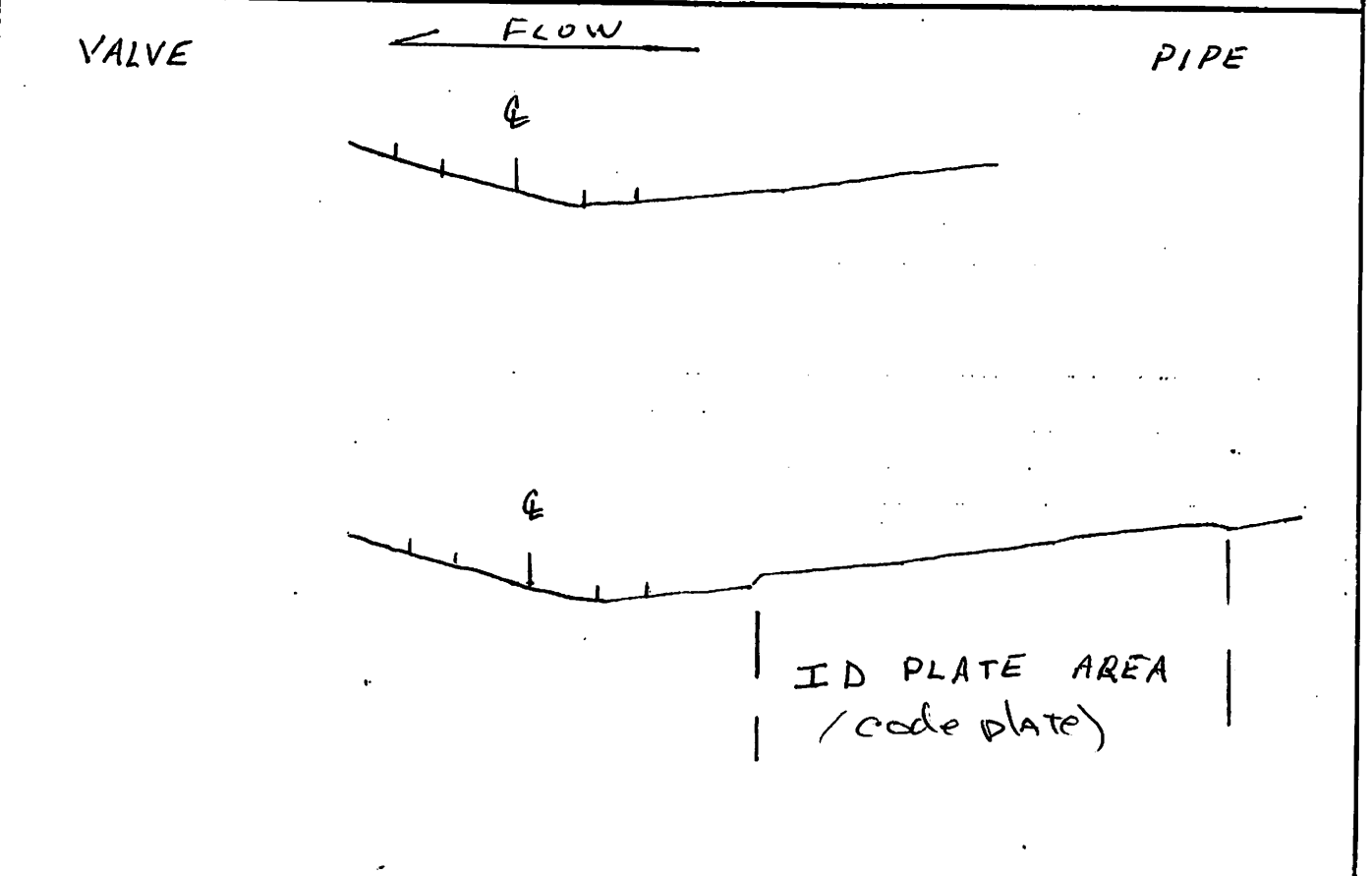

$L^1: 15.75$ $L^2: 20.75$ $W: 1.2$ (2.5 x 5.0 ID PLATE)

EXAMINER: <u><i>[Signature]</i></u>	REVIEWED BY: <u><i>[Signature]</i></u>	ANII: <u><i>[Signature]</i></u>
LEVEL: <u>II</u>	LEVEL: <u>III</u>	DATE: <u>7/24/15</u>
DATE: <u>02-25-15</u>	DATE: <u>5.6.15</u>	PAGE: <u>5</u> OF <u>6</u>

TVA

Office of Nuclear Power

PROJECT: WBN SYSTEM: SIS

REPORT NO.:

UNIT: 2 WELD NO: SIF-D197-11

R.P2466

VALVE

← FLOW

PIPE

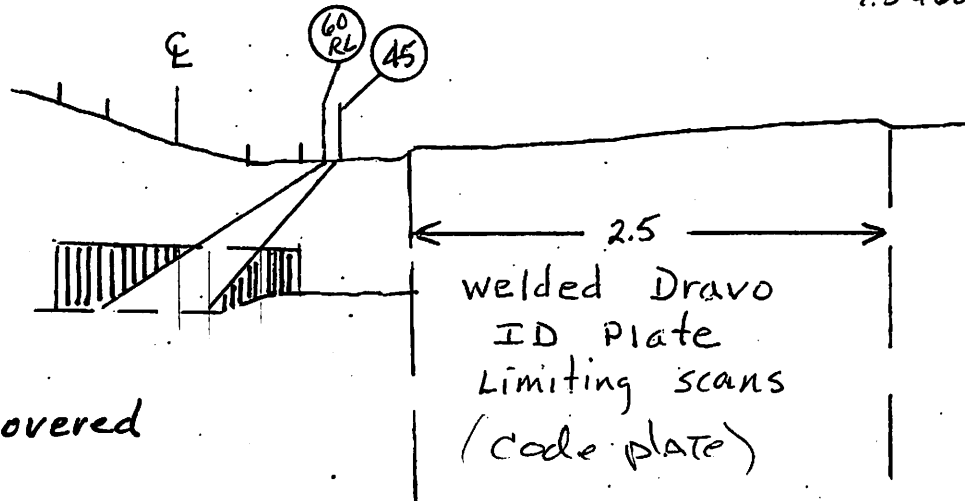
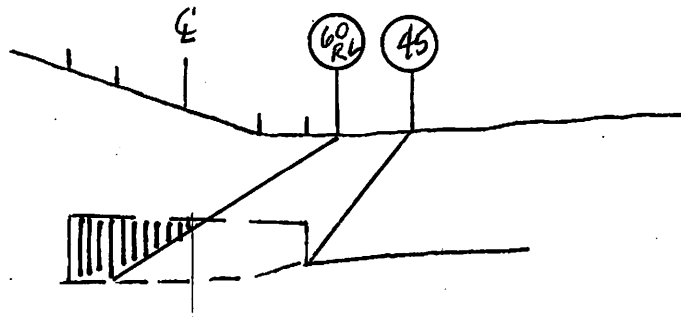

Area not covered

W X H X L
 $1.25 \times .25 \times 21 = 6.5625 \times 4 = 26.25$

Scan 3 = $1.25 \times .25 \times 15.75 = 4.921875$
 Scan 4 = 0
 Scan 5 = $.25 \times .25 = .0625 \times 21 = 1.3125$
 Skinc = $.25 \times .25 = .0625 \times 21 = 1.3125$
 $7.546875 \div 26.25 = .2875 \times 100 = 28.75\%$

BY:

[Signature]

LEVEL: II

DATE: 02-25-15 PAGE 6 OF 6

2/25/15