

**CHAPTER 10: STEAM AND POWER CONVERSION
TABLE OF CONTENTS**

CHAPTER 10 STEAM AND POWER CONVERSION	10.1-1
10.1 SUMMARY DESCRIPTION	10.1-1
10.1.3 COMBINED LICENSE INFORMATION ON EROSION-CORROSION MONITORING	10.1-1
10.1.3.1 Erosion-Corrosion Monitoring	10.1-1
10.1.3.2 Procedures	10.1-2
10.1.3.3 Plant Chemistry	10.1-3
10.1.4 REFERENCES	10.1-4
10.2 TURBINE-GENERATOR	10.2-1
10.2.2 SYSTEM DESCRIPTION	10.2-1
10.2.3 TURBINE ROTOR INTEGRITY	10.2-1
10.2.3.6 Maintenance and Inspection Program Plan	10.2-1
10.2.6 COMBINED LICENSE INFORMATION ON TURBINE MAINTENANCE AND INSPECTION	10.2-2
10.3 MAIN STEAM SUPPLY SYSTEM	10.3-1
10.3.5.4 Chemical Addition	10.3-1
10.3.6.2 Material Selection and Fabrication	10.3-2
10.4 OTHER FEATURES OF STEAM AND POWER CONVERSION SYSTEM	10.4-1
10.4.5 CIRCULATING WATER SYSTEM	10.4-1
10.4.5.1 Design Basis	10.4-1
10.4.5.2 System Description	10.4-2
10.4.5.3 Safety Evaluation	10.4-9
10.4.5.4 Tests and Inspections	10.4-9
10.4.5.5 Instrumentation Applications	10.4-10
10.4.12.1 Circulating Water System	10.4-12
10.4.12.2 Condensate, Feedwater and Auxiliary Steam System Chemistry Control	10.4-12
10.4.12.3 Potable Water	10.4-13
10.4.13 REFERENCES	10.4-13

CHAPTER 10 LIST OF TABLES

<u>Number</u>	<u>Title</u>
10.4-201	Supplemental Main Condenser Design Data
10.4-202	Supplemental Design Parameters for Major Circulating Water System Components

CHAPTER 10 LIST OF FIGURES

<u>Number</u>	<u>Title</u>
10.4-201	Circulating Water System Flow Diagram

CHAPTER 10 STEAM AND POWER CONVERSION

10.1 SUMMARY DESCRIPTION

This **section** of the referenced DCD is incorporated by reference with the following departures and/or supplements.

10.1.3 COMBINED LICENSE INFORMATION ON EROSION-CORROSION MONITORING

Add the following at the end of **DCD Subsection 10.1.3**.

10.1.3.1 Erosion-Corrosion Monitoring

STD COL 10.1-1 The flow accelerated corrosion (FAC) monitoring program analyzes, inspects, monitors and trends those nuclear power plant components that are potentially susceptible to erosion-corrosion damage such as carbon steel components that carry wet steam. In addition, the FAC monitoring program considers the information of Generic Letter 89-08, EPRI NSAC-202L-R3, and industry operating experience. The program requires a grid layout for obtaining consistent pipe thickness measurements when using Ultrasonic Test Techniques. The FAC program obtains actual thickness measurements for highly susceptible FAC locations for new lines as defined in EPRI NSAC-202L-R3 (**Reference 201**). At a minimum, a CHECWORKS type Pass 1 analysis is used for low and highly susceptible FAC locations and a CHECWORKS type Pass 2 analysis is used for highly susceptible FAC locations when the Pass 1 analysis results warrant. To determine wear of piping and components where operating conditions are inconsistent or unknown, the guidance provided in EPRI NSAC-202L is used to determine wear rates.

10.1.3.1.1 Analysis

An industry-sponsored program is used to identify the most susceptible components and to evaluate the rate of wall thinning for components and piping potentially susceptible to FAC. Each susceptible component is tracked in a database and is inspected, based on susceptibility. Analytical methods utilize the results of plant-specific inspection data to develop plant-specific correction factors. This correction accounts for uncertainties in plant data, and for systematic

discrepancies caused by plant operation. For each piping component, the analytical method predicts the wear rate, and the estimated time until it must be re-inspected, repaired, or replaced. Carbon steel piping (ASME III and B31.1) that is used for single or multi-phase high temperature flow are the most susceptible to erosion-corrosion damage and receive the most critical analysis.

10.1.3.1.2 Industry Experience

Review and incorporation of industry experience provides a valuable supplement to plant analysis. Industry experience is used to update the program by identifying susceptible components or piping features.

10.1.3.1.3 Inspections

Wall thickness measurements establish the extent of wear in a given component, provide data to help evaluate trends, and provide data to refine the predictive model. Components are inspected for wear using ultrasonic techniques (UT), radiography techniques (RT), or by visual observation. The initial inspections are used as a baseline for later inspections. Each subsequent inspection determines the wear rate for the piping and components and the need for inspection frequency adjustment for those components.

10.1.3.1.4 Training and Engineering Judgement

The FAC program is administered by both trained and experienced personnel. Task specific training is provided for plant personnel that implement the monitoring program. Specific nondestructive examination (NDE) is carried out by personnel qualified in the given NDE method. Inspection data is analyzed by engineers or other experienced personnel to determine the overall effect on the system or component.

10.1.3.1.5 Long-Term Strategy

This strategy focuses on reducing wear rates and performing inspections on the most susceptible locations.

10.1.3.2 Procedures

10.1.3.2.1 Generic Plant Procedure

The FAC monitoring program is governed by procedure. This procedure contains the following elements:

Turkey Point Units 6 & 7
COL Application
Part 2 — FSAR

- A requirement to monitor and control FAC.
- Identification of the tasks to be performed and associated responsibilities.
- Identification of the position that has overall responsibility for the FAC monitoring program at each plant.
- Communication requirements between the coordinator and other departments that have responsibility for performing support tasks.
- Quality Assurance requirements.
- Identification of long-term goals and strategies for reducing high FAC wear rates.
- A method for evaluating plant performance against long-term goals.

10.1.3.2.2 Implementing Procedures

The FAC implementing procedures provide guidelines for controlling the major tasks. The plant procedures for major tasks are as follows:

- Identifying susceptible systems.
- Performing FAC analysis.
- Selecting and scheduling components for initial inspection.
- Performing inspections.
- Evaluating degraded components.
- Repairing and replacing components when necessary.
- Selecting and scheduling locations for the follow-on inspections.
- Collection and storage of inspections records.

10.1.3.3 Plant Chemistry

The responsibility for system chemistry is under the purview of the plant chemistry section. The plant chemistry section specifies chemical addition in accordance with plant procedures.

Add the following after **DCD Subsection 10.1.3**:

10.1.4 REFERENCES

201. Electric Power Research Institute, *Recommendations for an Effective Flow—Accelerated Corrosion Program (NSAC-202L-R3)*, EPRI Report TR-1011838, Palo Alto, California, 2006.
-

10.2 TURBINE-GENERATOR

This **section** of the referenced DCD is incorporated by reference with the following departures and/or supplements.

10.2.2 SYSTEM DESCRIPTION

Add the following sentence at the end of the second paragraph of **DCD Subsection 10.2.2**.

STD SUP 10.2-1 **Subsection 3.5.1.3** addresses the probability of generation of a turbine missile for AP1000 plants in a side-by-side configuration.

Add the following statement at the end of **DCD Subsection 10.2.2**

STD SUP 10.2-4 Preoperational and startup tests provide guidance to operations personnel to ensure the proper operability of the turbine generator system.

10.2.3 TURBINE ROTOR INTEGRITY

Add the following statement at the end of **DCD Subsection 10.2.3**.

STD SUP 10.2-5 Operations and maintenance procedures mitigate the following potential degradation mechanisms in the turbine rotor and buckets/blades: pitting, stress corrosion cracking, corrosion fatigue, low-cycle fatigue, erosion, and erosion-corrosion.

10.2.3.6 Maintenance and Inspection Program Plan

Add the following at the end of **DCD Subsection 10.2.3.6**.

Turkey Point Units 6 & 7
COL Application
Part 2 — FSAR

STD SUP 10.2-3 The inservice inspection (ISI) program for the turbine assembly provides assurance that rotor flaws that lead to brittle fracture of a rotor are detected. The ISI program also coincides with the ISI schedule during shutdown, as required by the ASME Boiler and Pressure Vessel Code, Section XI, and includes complete inspection of all significant turbine components, such as couplings, coupling bolts, turbine shafts, low-pressure turbine blades, low-pressure rotors, and high-pressure rotors. This inspection consists of visual, surface, and volumetric examinations required by the code.

10.2.6 COMBINED LICENSE INFORMATION ON TURBINE MAINTENANCE
AND INSPECTION

Replace the text in **DCD Subsection 10.2.6** with the following:

STD COL 10.2-1 A turbine maintenance and inspection program will be submitted to the NRC staff for review prior to fuel load. The program will be consistent with the maintenance and inspection program plan activities and inspection intervals identified in **DCD Subsection 10.2.3.6**. Plant-specific turbine rotor test data and calculated toughness curves that support the material property assumptions in the turbine rotor analysis will be available for review after fabrication of the turbine and prior to fuel load.

10.3 MAIN STEAM SUPPLY SYSTEM

This **section** of the referenced DCD is incorporated by reference with the following departures and/or supplements.

10.3.2.2.1 Main Steam Piping

Add the following at the end of **DCD Subsection 10.3.2.2.1**.

STD SUP 10.3-1 Operations and maintenance procedures include precautions, when appropriate, to minimize the potential for steam and water hammer, including:

- Prevention of rapid valve motion
 - Process for avoiding introduction of voids into water-filled lines and components
 - Proper filling and venting of water-filled lines and components
 - Process for avoiding introduction of steam or heated water that can flash into water-filled lines and components
 - Cautions for introduction of water into steam-filled lines or components
 - Proper warmup of steam-filled lines
 - Proper drainage of steam-filled lines
 - The effects of valve alignments on line conditions
-

10.3.5.4 Chemical Addition

Add the following at the end of **DCD Subsection 10.3.5.4**.

STD SUP 10.3-2 Alkaline chemistry supports maintaining iodine compounds in their nonvolatile form. When iodine is in its elemental form, it is volatile and free to react with

Turkey Point Units 6 & 7
COL Application
Part 2 — FSAR

organic compounds to create organic iodine compounds, which are not assumed to remain in solution. It is noted that no significant level of organic compounds is expected in the secondary system. The secondary water chemistry, thus, does not directly impact the radioactive iodine partition coefficients.

10.3.6.2 Material Selection and Fabrication

Add the following at the end of **DCD Subsection 10.3.6.2**.

STD SUP 10.3-3 Appropriate operations and maintenance procedures will provide the necessary controls during operation to minimize the susceptibility of components made of stainless steel and nickel-based materials to intergranular stress-corrosion cracking by controlling chemicals that are used on system components.

10.4 OTHER FEATURES OF STEAM AND POWER CONVERSION SYSTEM

This **section** of the referenced DCD is incorporated by reference with the following departures and/or supplements.

10.4.2.2.1 General Description

Revise the first sentence of the third paragraph of **DCD Subsection 10.4.2.2.1** to remove the brackets.

PTN CDI

The circulating water system (CWS) provides the cooling water for the vacuum pump seal water heat exchangers.

10.4.2.2.2 Component Description

Revise the fourth sentence of the first paragraph of **DCD Subsection 10.4.2.2.2** to remove the brackets.

PTN CDI

Seal water flows through the shell side of the seal water heat exchanger and circulating water flows through the tube side.

Subsection 10.4.5 is modified using full text incorporation to provide site specific information to replace the DCD conceptual design information (CDI).

DCD

10.4.5 CIRCULATING WATER SYSTEM

10.4.5.1 Design Basis

10.4.5.1.1 Safety Design Basis

The circulating water system (CWS) serves no safety-related function and therefore has no nuclear safety design basis.

10.4.5.1.2 Power Generation Design Basis

Turkey Point Units 6 & 7
COL Application
Part 2 — FSAR

PTN CDI The circulating water system supplies cooling water to remove heat from the main condenser, the turbine building closed cooling water system (TCS) heat exchangers, and the condenser vacuum pump seal water heat exchangers, under varying conditions of power plant loading and design weather conditions.

DCD 10.4.5.2 System Description

10.4.5.2.1 General Description

Classification of components and equipment in the circulating water system is given in [Section 3.2](#).

PTN COL 10.4-1 The CWS provides a heat sink for the waste heat exhausted from the steam turbine to the main condenser and dissipates this waste heat to the atmosphere using cooling towers. The CWS also provides cooling for the TCS heat exchangers and the condenser vacuum pump seal water heat exchangers. The CWS is shown in [Figure 10.4-201](#). CWS design parameters are provided in [Tables 10.4-201](#) and [10.4-202](#).

PTN CDI The CWS consists of three 33-1/3 percent capacity circulating water pumps, three mechanical draft cooling towers, and associated piping, valves, and instrumentation per unit.

DCD Makeup water to the CWS is provided by the raw water system (RWS). In addition, water chemistry is controlled by a local chemical feed system.

PTN CDI The RWS includes two sources of water available for makeup water to the CWS. One source is reclaimed water from the Miami-Dade Water and Sewer Department and the second source is saltwater from the radial collector wells. The CWS is capable of operating with either water source alone and with a combination of the two sources. The reclaimed water portion of the RWS is

shown in **Figure 9.2-201**, Sheet 1 of 3. The saltwater portion of the RWS is shown in **Figure 9.2-201**, Sheet 2 of 3.

10.4.5.2.2 Component Description

DCD

Circulating Water Pumps

PTN CDI

The three circulating water pumps are vertical, wet pit, single-stage, mixed-flow pumps driven by electric motors. The pumps are mounted in an intake structure connected to the cooling tower basins by open flumes. The three pump discharge lines combine in a single main header at the intake structure. This main header with two supply lines to the turbine building forms a common header that connects to the two inlet water boxes of the condenser and may also supply cooling water to the TCS and condenser vacuum pump seal water heat exchangers. Each pump discharge line has a motor-operated butterfly valve located between the pump discharge and the main header. This permits isolation of one pump for maintenance and allows two-pump operation.

Cooling Towers

PTN COL 10.4-1

Three mechanical-induced draft, counterflow cooling towers are designed to reject a single unit's full-load waste heat to the atmosphere. The cooling towers are designed to cool the circulating water to 91°F or less based on 1 percent annual exceedance wet bulb temperature of 80.6°F. Heat is rejected to the atmosphere primarily through evaporative cooling as circulating water returned from the condenser drops through the tower fill to the tower basins from which it is returned through open flumes to the CWS intake structure. Operation of the cooling towers during conditions that are more restrictive than design conditions may result in higher condenser back pressure.

PTN CDI

When more than one cooling tower is located on a site, a portion of the saturated effluent of an upwind tower can intermix with the air entering a tower located downwind, elevating its inlet wet bulb temperature. This phenomenon is known as "interference" and it results in decreased performance of the downwind tower.

Proper cooling tower placement and orientation can minimize the effect of interference. Since the SWS and the CWS towers are located remotely to each other and the saturated effluent dissipates before it interferes with the intake of the SWS, the CWS towers would not adversely affect the performance of the SWS towers.

Cooling Tower Makeup and Blowdown

DCD The circulating water system makeup is provided by the raw water system.

PTN CDI Makeup to and blowdown from the CWS is controlled by the makeup and blowdown control valves, respectively. These valves, along with the local chemical feed system, provide chemistry control in the circulating water to maintain a noncorrosive, nonscale-forming condition and limit biological growth in the CWS components.

Piping and Valves

PTN CDI The underground portions of the CWS piping are constructed of prestressed concrete pressure piping. The remainder of the piping is carbon steel and is coated internally with a corrosion-resistant compound.

PTN COL 10.4-1 Condenser water box drain lines allow the condenser to be drained to the turbine building sumps. Condenser water box drain lines can also be aligned to the cooling tower basin. Administrative controls prevent the release of circulating water radioactivity in a condenser water box to the cooling tower basin. Each water box contains drain valves and vents so that a water box can be drained individually. Piping is sized to support an adequate drain down in the event of emergency maintenance.

DCD Motor-operated butterfly valves are provided in each of the circulating water lines at their inlet to and exit from the condenser shell to allow isolation of portions of the condenser.

PTN CDI Control valves provide regulation of cooling tower blowdown and makeup.

DCD The circulating water system is designed to withstand the maximum operating discharge pressure of the circulating water pumps.

PTN CDI Piping includes the expansion joints, butterfly valves, condenser water boxes, and tube bundles.

PTN COL 10.4-1 The design pressure of the condenser portions of the piping is identified in **DCD Table 10.4.1-1**. The design pressure of the remaining piping is 110 psig.

DCD **Circulating Water Chemical Injection**

Circulating water chemistry is maintained by a local chemical feed system skid at the CWS cooling tower.

PTN CDI Circulating water system chemical feed equipment injects the required chemicals into the circulating water at the CWS cooling tower basin.

DCD This maintains a noncorrosive, nonscale-forming condition and limits the biological film formation that reduces the heat transfer rate in the condenser and the heat exchangers supplied by the circulating water system.

Turkey Point Units 6 & 7
COL Application
Part 2 — FSAR

PTN COL 10.4-1 The specific chemicals used within the system are based on water conditions as determined by CWS water chemistry.

DCD The chemicals can be divided into six categories based upon function: biocide, algaecide, pH adjuster, corrosion inhibitor, scale inhibitor, and a silt dispersant. The pH adjuster, corrosion inhibitor, scale inhibitor, and dispersant are metered into the system continuously or as required to maintain proper concentrations. The biocide application frequency may vary with seasons.

PTN CDI The algaecide is applied, as necessary, to control algae formation on the cooling tower.

PTN COL 10.4-1 The following chemicals are used to control circulating water chemistry:

- Biocide and algaecide - sodium hypochlorite
- pH adjuster - sulfuric acid
- Corrosion inhibitor/scale inhibitor/silt dispersant - High stress polymer
- Scale inhibitor - sodium salt of phosphonometylate diamine and/or silicate inhibiting polymer

DCD Addition of biocide and water treatment chemicals is performed by local chemical feed injection metering pumps and is adjusted as required.

PTN CDI Chemical concentrations are measured through analysis of grab samples from the CWS.

Turkey Point Units 6 & 7
COL Application
Part 2 — FSAR

DCD Residual chlorine is measured to monitor the effectiveness of the biocide treatment.

PTN CDI Chemical injections are interlocked with each circulating water pump to prevent chemical injection when the circulating water pumps are not running.

DCD 10.4.5.2.3 System Operation

PTN CDI The three circulating water pumps take suction from the circulating water intake structure and circulate the water through the tube side of the main condenser, with smaller flows to the TCS and the condenser vacuum pump seal heat exchangers, and back through the piping discharge network to the cooling towers (see [Figure 10.4-201](#)). The cooling towers cool the circulating water by discharging the water above the tower fill material, through which the water then falls to the basin beneath the towers and, in the process, rejects heat to the atmosphere.

Circulating water flow to the cooling towers can be diverted to the basins, bypassing the cooling towers' internals by opening the bypass valves. The bypass can be used during plant startup or partial load or to maintain CWS temperatures above 40°F while operating during periods of cold weather.

The raw water system supplies makeup water to the cooling tower basins to replace water losses due to evaporation, drift, and blowdown. Separate connections are provided between the RWS and CWS to initially fill the CWS piping. The connections to the CWS are downstream of the CWS pump isolation valves.

DCD A condenser tube cleaning system is installed to clean the circulating water side of the main condenser tubes.

PTN CDI Blowdown from the circulating water system is taken from the discharge header of the circulating water system pumps, and is discharged to the blowdown sump.

Turkey Point Units 6 & 7
COL Application
Part 2 — FSAR

DCD The circulating water system is used to supply cooling water to the main condenser to condense the steam exhausted from the main turbine.

PTN CDI If the circulating water system malfunctions such that the condenser backpressure rises above the maximum allowable value, the main condenser will no longer be able to adequately support unit operation.

DCD Cooldown of the reactor may be accomplished by using the power-operated atmospheric steam relief valves or safety valves rather than the turbine bypass system when the condenser is not available.

Passage of condensate from the main condenser into the circulating water system through a condenser tube leak is not possible during power generation operation, since the circulating water system operates at a greater pressure than the condenser.

PTN CDI Turbine building closed cooling water in the TCS heat exchangers is maintained at a higher pressure than the circulating water to prevent leakage of the circulating water into the closed cooling water system.

Cooling water to the condenser vacuum pump seal water heat exchangers is supplied from the circulating water system. Cooling water flow from the circulating water system is normally maintained through all four heat exchangers to facilitate placing the spare condenser vacuum pump in service.

DCD Isolation valves are provided for the condenser vacuum pump seal water heat exchanger cooling water supply lines to facilitate maintenance.

Small circulating water system leaks in the turbine building will drain into the waste water system. Large circulating water system leaks due to pipe failures will be indicated in the control room by a loss of vacuum in the condenser shell. The effects of flooding due to a circulating water system failure, such as the rupture of

Turkey Point Units 6 & 7
COL Application
Part 2 — FSAR

an expansion joint, will not result in detrimental effects on safety-related equipment since there is no safety-related equipment in the turbine building and the base slab of the turbine building is located at grade elevation. Water from a system rupture will run out of the building through a relief panel in the turbine building west wall before the level could rise high enough to cause damage. Site grading will carry the water away from safety-related buildings.

PTN CDI

Each of the mechanical draft cooling towers is positioned so that its collapse would have no potential to damage structures, systems, and components (SSCs) required for safe shutdown of the plant. External flooding resulting from a failure of the cooling tower basins, flumes or associated circulating water system piping would have no adverse effect on safety-related SSCs, due to the location of the cooling towers (greater than 600 feet from safety-related SSCs) in combination with site grading to direct surface water away from the nuclear island.

DCD

10.4.5.3 Safety Evaluation

The circulating water system has no safety-related function and therefore requires no nuclear safety evaluation.

10.4.5.4 Tests and Inspections

Components of the circulating water system are accessible as required for inspection during plant power generation.

PTN CDI

The circulating water pumps are tested in accordance with standards of the Hydraulic Institute.

DCD

Performance, hydrostatic, and leakage tests associated with preinstallation and preoperational testing are performed on the circulating water system. The system performance and structural and leaktight integrity of system components are demonstrated by continuous operation.

Turkey Point Units 6 & 7
COL Application
Part 2 — FSAR

10.4.5.5 Instrumentation Applications

PTN CDI

Instrumentation provided indicates the open and closed positions of motor-operated butterfly valves in the circulating water piping. The motor-operated valve at each pump discharge is interlocked with the pump so that the pump trips if the discharge valve fails to reach the full-open position shortly after starting the pump.

Local grab samples are used to periodically test the circulating water quality to limit harmful effects to the system piping and valves due to improper water chemistry.

Pressure indication is provided on the circulating water pump discharge lines.

DCD

A differential pressure transmitter is provided between one inlet and outlet branch to the condenser. This differential pressure transmitter is used to determine the frequency of operating the condenser tube cleaning system (CES).

PTN CDI

Temperature indication is supplied on the common CWS inlet header to the TCS heat exchanger trains. This temperature is also representative of the inlet cooling water temperature to the main condenser.

A flow element is provided on the common discharge line from the TCS heat exchangers to allow monitoring of the total flow through the TCS heat exchangers. Flow measurement for the raw water makeup to the cooling tower and for the circulating water system blowdown is also provided.

Level instrumentation provided in the circulating water intake structure activates makeup flow from the RWS to the cooling tower basins. Level instrumentation also annunciates a low water level in the intake structure, and a high water level in the cooling tower basins.

PTN COL 10.4-1

The circulating water chemistry is controlled by CWS blowdown and chemical addition to maintain the circulating water with an acceptable Langelier Index range as described in [Subsection 10.4.12.1](#). The system accomplishes this by regulating the blowdown valve. This regulation causes the tower basin water level to

fluctuate. This fluctuation is sensed by a level controller that operates the cooling tower makeup valves.

DCD The control approach is to allow the makeup water to concentrate naturally to its upper limit. Provisions are made to add chemicals for pH control.

PTN CDI The cycles of concentration at which the cooling tower is operated depends on the quality of the cooling tower makeup water. The cooling water blowdown is discharged to the blowdown sump.

DCD Monitoring of the circulating water system is performed through the data display and processing system. Control functions are performed by the plant control system. Appropriate alarms and displays are available in the control room. See Chapter 7.

10.4.7.2.1 General Description

Replace the last sentence of the sixth paragraph of **DCD Subsection 10.4.7.2.1** as follows.

PTN COL 10.4-2 The oxygen scavenger agent is hydrazine and/or carbohydrazide and the pH control agent is morpholine.

PTN SUP 10.4-2 Oxygen scavenging and pH control agents are selected and utilized for plant secondary water chemistry optimization following the guidance of NEI-97-06, "Steam Generator Program Guidelines" (**Reference 201**). The EPRI Pressurized Water Reactor Secondary Water Chemistry Guidelines are followed as described in NEI 97-06.

Add new paragraph at the end of the [DCD Subsection 10.4.7.2.1](#):

STD SUP 10.4-1 Operations and maintenance procedures include precautions, when appropriate, to minimize the potential for steam and water hammer, including:

- Prevention of rapid valve motion
- Process for avoiding introduction of voids into water-filled lines and components
- Proper filling and venting of water-filled lines and components
- Process for avoiding introduction of steam or heated water that can flash into water-filled lines and components
- Cautions for introduction of water into steam-filled lines or components
- Proper warmup of steam-filled lines
- Proper drainage of steam-filled lines
- The effects of valve alignments on line conditions

10.4.12.1 Circulating Water System

PTN COL 10.4-1 This COL Item is addressed in [Subsection 10.4.5](#) with specific descriptions of CWS configuration in [Subsection 10.4.5.2.1](#), design pressure and cooling towers in [Subsection 10.4.5.2.2](#), and specific chemicals and chemistry in [Subsections 10.4.5.2.2](#) and [10.4.5.5](#).

10.4.12.2 Condensate, Feedwater and Auxiliary Steam System Chemistry Control

PTN COL 10.4-2 This COL Item is addressed in [Subsection 10.4.7.2.1](#).

Turkey Point Units 6 & 7
COL Application
Part 2 — FSAR

10.4.12.3 Potable Water

Replace the entire paragraph for **DCD Subsection 10.4.12.3** with the following.

PTN COL 10.4-3 This COL Item is duplicated in the **Subsection 9.2.13.1** COL Item and is addressed as stated in that subsection.

10.4.13 REFERENCES

201. Nuclear Energy Institute, *Steam Generator Program Guidelines*, NEI 97-06, Rev. 2, May 2005.
-

Turkey Point Units 6 & 7
COL Application
Part 2 — FSAR

PTN CDI

Table 10.4-201
Supplemental Main Condenser Design Data

Condenser Data

Circulating water flow	600,000 gpm
------------------------	-------------

Note: This table supplements **DCD Table 10.4.1-1**.

PTN COL 10.4-1

Table 10.4-202
Supplemental Design Parameters for Major Circulating Water System Components

Circulating Water Pump

Quantity	3 per unit
Flow rate (gallons/minute)	220,000

Mechanical Draft Cooling Tower

Quantity	3 per unit
Approach temperature	7.1°F
Inlet water temperatures	115.4°F
Outlet water temperature	91°F
Approximate temperature range	24.4°F
Flow rate, each (gallons/minute)	210,000
Heat transfer, each (Btu/hour)	2.543E09
Wind velocity design (mph)	146
Seismic design criteria in accordance with Florida building code	

Note: This table supplements [DCD Table 10.4.5-1](#).

Turkey Point Units 6 & 7
 COL Application
 Part 2 — FSAR

PTN CDI

Figure 10.4-201 Circulating Water System Flow Diagram

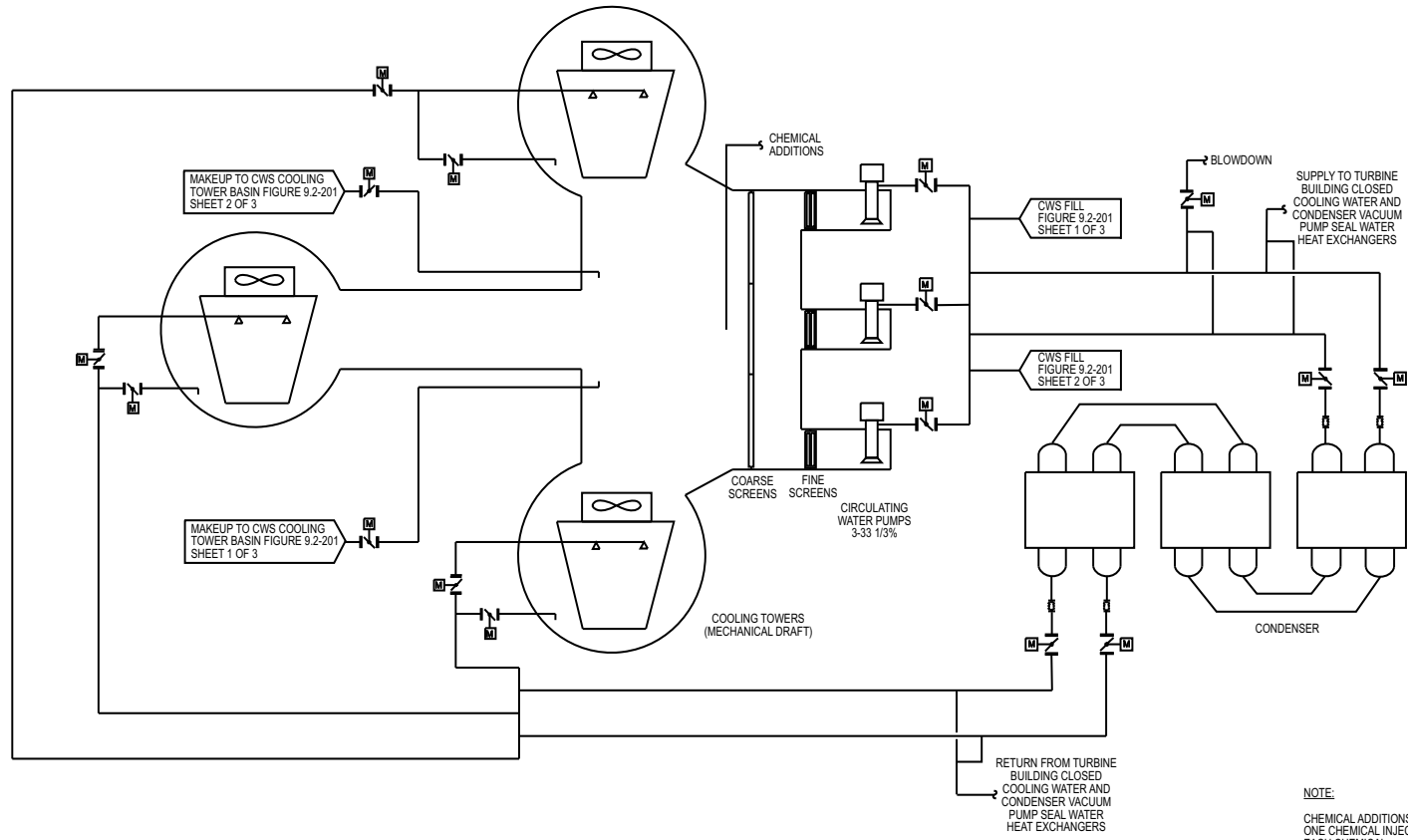

NOTE:
 CHEMICAL ADDITIONS WILL HAVE ONE CHEMICAL INJECTION POINT FOR EACH CHEMICAL.