

**UNITED STATES NUCLEAR REGULATORY COMMISSION
BOILING WATER REACTOR GENERIC FUNDAMENTALS EXAMINATION
SEPTEMBER 2009 -- FORM A**

Please Print

Name: _____

Docket No.: _____

Facility: _____

Start Time: _____ Stop Time: _____

INSTRUCTIONS TO APPLICANT

Answer all the test items using the answer sheet provided, ensuring a single answer is marked for each test item. Each test item has equal point value. A score of at least 80% is required to pass this portion of the NRC operator licensing written examination. All examination materials will be collected 3.0 hours after the examination begins. This examination applies to a typical U.S. boiling water reactor (BWR) nuclear power plant.

SECTION	QUESTIONS	% OF TOTAL	SCORE
COMPONENTS	1 - 22		
REACTOR THEORY	23 - 36		
THERMODYNAMICS	37 - 50		
TOTALS	50		

All work performed on this examination is my own. I have neither given nor received aid.

Applicant's Signature

**RULES AND INSTRUCTIONS FOR THE NRC
GENERIC FUNDAMENTALS EXAMINATION**

During the administration of this examination the following rules apply:

NOTE: The term "control rod" refers to the length of neutron absorber material that can be positioned by the operator to change core reactivity.

NOTE: Numerical answers are rounded to the nearest whole number unless otherwise indicated.

1. Print your name in the blank provided on the cover sheet of the examination.
2. Fill in your individual docket number.
3. Fill in the name of your facility.
4. Fill in your start and stop times at the appropriate time.
5. Two aids are provided for your use during the examination:
 - (1) An equations and conversions sheet contained within the examination copy, and
 - (2) Steam tables and Mollier Diagram provided by your proctor.
6. Place your answers on the answer sheet provided. Credit will only be given for answers properly marked on this sheet. Follow the instructions for filling out the answer sheet.
7. Scrap paper will be provided for calculations.
8. Cheating on the examination will result in the automatic forfeiture of this examination. Cheating could also result in severe penalties.
9. Restroom trips are limited. Only **ONE** examinee may leave the room at a time. In order to avoid the appearance or possibility of cheating, avoid all contact with anyone outside of the examination room.
10. After you have completed the examination, sign the statement on the cover sheet indicating that the work is your own and you have neither given nor received any assistance in completing the examination. Either pencil or pen may be used.
11. Turn in your examination materials, answer sheet on top, followed by the examination copy and the examination aids, e.g., steam tables, handouts, and scrap paper.
12. After turning in your examination materials, leave the examination area, as defined by the proctor. If after leaving you are found in the examination area while the examination is in progress, your examination may be forfeited.

GENERIC FUNDAMENTALS EXAMINATION
EQUATIONS AND CONVERSIONS HANDOUT SHEET

EQUATIONS

$$\dot{Q} = \dot{m}c_p\Delta T$$

$$\dot{Q} = \dot{m}\Delta h$$

$$\dot{Q} = UA\Delta T$$

$$\dot{Q} \propto \dot{m}_{\text{Nat}}^3 \text{ Circ}$$

$$\Delta T \propto \dot{m}_{\text{Nat}}^2 \text{ Circ}$$

$$K_{\text{eff}} = 1/(1 - \rho)$$

$$\rho = (K_{\text{eff}} - 1)/K_{\text{eff}}$$

$$\text{SUR} = 26.06/\tau$$

$$\tau = \frac{\bar{\beta}_{\text{eff}} - \rho}{\lambda_{\text{eff}} \rho}$$

$$\rho = \frac{\ell^*}{\tau} + \frac{\bar{\beta}_{\text{eff}}}{1 + \lambda_{\text{eff}} \tau}$$

$$\ell^* = 1 \times 10^{-4} \text{ sec}$$

$$\lambda_{\text{eff}} = 0.1 \text{ sec}^{-1} \text{ (for small positive } \rho)$$

$$\text{DRW} \propto \Phi_{\text{tip}}^2 / \Phi_{\text{avg}}^2$$

$$P = P_o 10^{\text{SUR}(t)}$$

$$P = P_o e^{(t/\tau)}$$

$$A = A_o e^{-\lambda t}$$

$$\text{CR}_{\text{S/D}} = S/(1 - K_{\text{eff}})$$

$$\text{CR}_1(1 - K_{\text{eff}1}) = \text{CR}_2(1 - K_{\text{eff}2})$$

$$1/M = \text{CR}_1/\text{CR}_x$$

$$A = \pi r^2$$

$$F = PA$$

$$\dot{m} = \rho A \bar{v}$$

$$\dot{W}_{\text{Pump}} = \dot{m}\Delta P v$$

$$E = IR$$

$$\text{Thermal Efficiency} = \text{Net Work Out}/\text{Energy In}$$

$$\frac{g(z_2 - z_1)}{g_c} + \frac{(\bar{v}_2^2 - \bar{v}_1^2)}{2g_c} + v(P_2 - P_1) + (u_2 - u_1) + (q - w) = 0$$

$$g_c = 32.2 \text{ lbm-ft/lbf-sec}^2$$

CONVERSIONS

$$1 \text{ Mw} = 3.41 \times 10^6 \text{ Btu/hr}$$

$$1 \text{ hp} = 2.54 \times 10^3 \text{ Btu/hr}$$

$$1 \text{ Btu} = 778 \text{ ft-lbf}$$

$$^\circ\text{C} = (5/9)(^\circ\text{F} - 32)$$

$$^\circ\text{F} = (9/5)(^\circ\text{C}) + 32$$

$$1 \text{ Curie} = 3.7 \times 10^{10} \text{ dps}$$

$$1 \text{ kg} = 2.21 \text{ lbm}$$

$$1 \text{ gal}_{\text{water}} = 8.35 \text{ lbm}$$

$$1 \text{ ft}^3_{\text{water}} = 7.48 \text{ gal}$$

**USNRC GENERIC FUNDAMENTALS EXAMINATION
SEPTEMBER 2009 BWR--FORM A**

QUESTION: 1

A completely full water storage tank is being hydrostatically tested to 200 psig using a positive displacement pump (PDP) with a smooth and constant discharge flow rate of 8 gpm. The tank is protected by a relief valve and a safety valve that discharge to the atmosphere. The valves have the following characteristics:

- The relief valve opening setpoint is 200 psig with an accumulation of 5 percent.
- The safety valve opening setpoint is 240 psig with a blowdown of 5 percent.
- Both valves have a maximum discharge flow rate of 6 gpm.

The PDP is inadvertently left running when tank pressure reaches 200 psig.

With the PDP still running, the relief valve will be _____ open; and the safety valve will be discharging an average flow rate of _____.

- A. partially; 6 gpm
- B. partially; 2 gpm
- C. fully; 6 gpm
- D. fully; 2 gpm

**USNRC GENERIC FUNDAMENTALS EXAMINATION
SEPTEMBER 2009 BWR--FORM A**

QUESTION: 2

Refer to the centrifugal pump operating curve with two system head loss curves (see figure below). The curves apply to an open cooling water system using one single-speed centrifugal pump discharging through a typical flow control valve.

One of the system curves shows system head loss with the flow control valve 25% open. The other system curve shows system head loss with the flow control valve 100% open. The pump is operating and the valve is initially 25% open, resulting in a pump flow rate of 800 gpm.

If the flow control valve is subsequently fully opened, pump flow rate through the valve will be approximately...

- A. 400 gpm.
- B. 1,200 gpm.
- C. 1,600 gpm.
- D. 3,200 gpm.

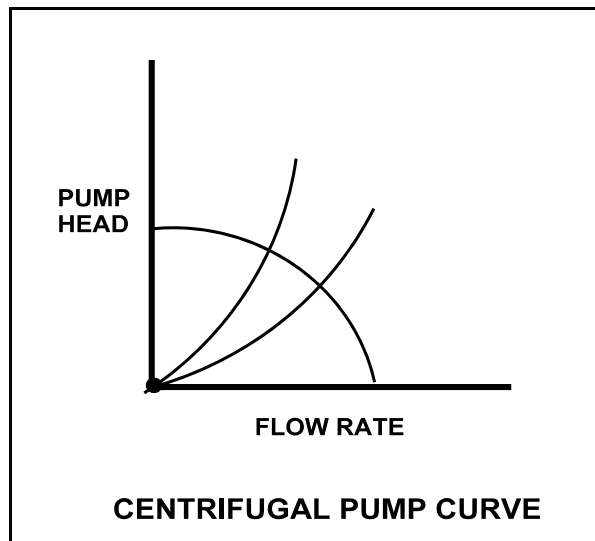

**USNRC GENERIC FUNDAMENTALS EXAMINATION
SEPTEMBER 2009 BWR--FORM A**

QUESTION: 3

Which one of the following is a generally accepted method for locally verifying that a manual valve is fully closed in a depressurized static piping system?

- A. Check a downstream flow gauge to be indicating zero flow.
- B. Compare an upstream and downstream pressure gauge to ensure zero differential pressure.
- C. Attempt to turn the valve handwheel in the close direction and verify no movement.
- D. Attempt to turn the valve handwheel in the open direction and verify movement.

QUESTION: 4

Consider water flowing through a frictionless venturi with no heat gain or loss.

For the above system, flow rate through the venturi is proportional to the square root of differential pressure. For steam flow, the relationship must be modified to account for changes in steam _____ as it flows through the venturi.

- A. velocity
- B. enthalpy
- C. internal energy
- D. specific volume

**USNRC GENERIC FUNDAMENTALS EXAMINATION
SEPTEMBER 2009 BWR--FORM A**

QUESTION: 5

Refer to the drawing of a tank differential pressure (D/P) level detection system (see figure below).

The D/P level detector was just calibrated and returned to operation with the following conditions:

- The reference leg contains 20 feet of water at 70°F.
- The tank contains 18 feet of water at 70°F.
- Tank level indication is 18 feet.

Assume the actual tank water level, and the temperature of the water in the tank and reference leg do not change. Which one of the following will be the new tank level indication if the reference leg water level decreases to 18 feet?

- A. 22 feet
- B. 20 feet
- C. 18 feet
- D. 2 feet

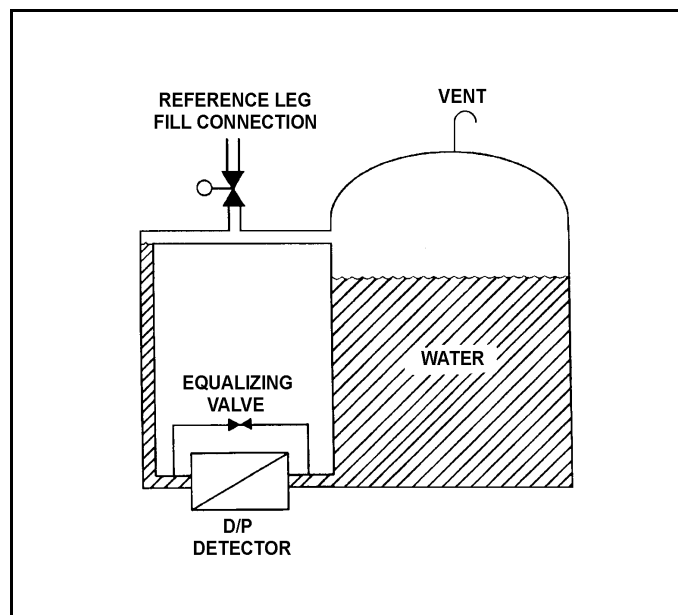

**USNRC GENERIC FUNDAMENTALS EXAMINATION
SEPTEMBER 2009 BWR--FORM A**

QUESTION: 6

Which one of the following devices is commonly used to provide remote indication of valve position on an analog meter in units of "percent of full open"?

- A. Limit switch
- B. Reed switch
- C. Linear variable differential transformer
- D. Resistance temperature detector

QUESTION: 7

An ion chamber radiation detector is exposed to a constant gamma radiation field. If the applied voltage is increased but maintained within the ion chamber region, the rate of ion collection will...

- A. increase because more secondary ionizations are occurring in the detector.
- B. stay approximately the same because all of the primary ions were already being collected at the lower voltage.
- C. increase because less primary ions are recombining in the detector prior to reaching the electrodes.
- D. stay approximately the same because the ion chamber is operating at saturated conditions.

**USNRC GENERIC FUNDAMENTALS EXAMINATION
SEPTEMBER 2009 BWR--FORM A**

QUESTION: 8

Consider a direct-acting proportional flow controller that is maintaining flow rate at a value that is offset from the controller setpoint. If the controller's gain is decreased, the controller's offset will _____ and the controller's proportional band will _____.

- A. decrease; decrease
- B. decrease; increase
- C. increase; decrease
- D. increase; increase

**USNRC GENERIC FUNDAMENTALS EXAMINATION
SEPTEMBER 2009 BWR--FORM A**

QUESTION: 9

Refer to the drawing of a pneumatic control system (see figure below).

The purpose of the valve positioner is to convert...

- A. a small control air pressure into a proportionally larger air pressure to adjust valve position.
- B. a large control air pressure into a proportionally smaller air pressure to adjust valve position.
- C. pneumatic force into mechanical force to adjust valve position.
- D. mechanical force into pneumatic force to adjust valve position.

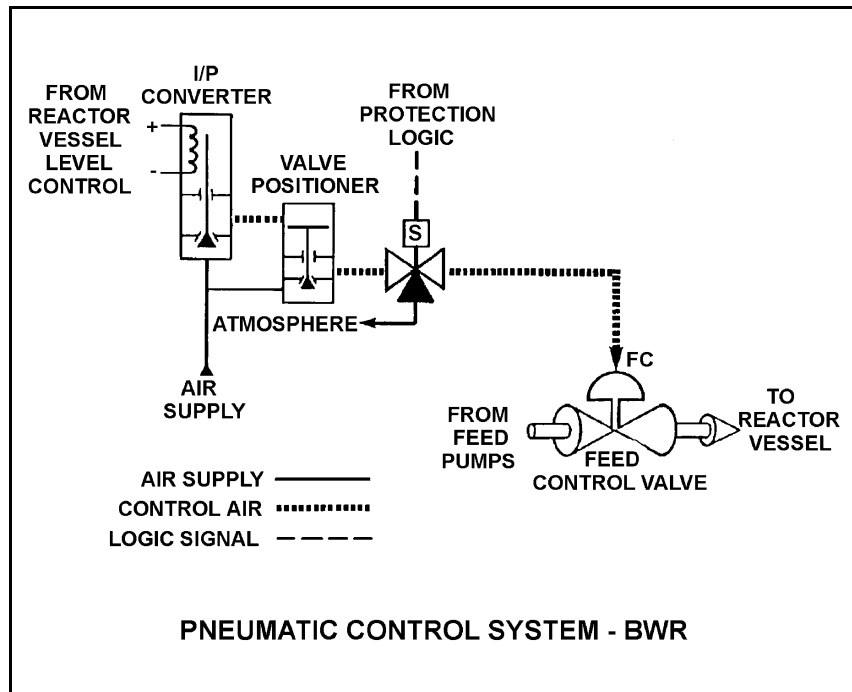

**USNRC GENERIC FUNDAMENTALS EXAMINATION
SEPTEMBER 2009 BWR--FORM A**

QUESTION: 10

An ac motor-driven centrifugal pump is operating with the following parameters:

Flow rate: 300 gpm

Power input: 4 KW

Pump speed is increased and flow rate increases to 400 gpm.

Which one of the following is the approximate value of the new power consumption?

A. 5.3 KW

B. 7.1 KW

C. 9.5 KW

D. 11.7 KW

QUESTION: 11

A centrifugal pump is operating in parallel with a positive displacement pump in an open water system. Each pump has the same maximum design pressure.

If pump discharge pressure increases to the maximum design pressure of each pump, the centrifugal pump will be operating at _____ flow and the positive displacement pump will be operating near _____ flow.

A. minimum; minimum

B. minimum; maximum rated

C. maximum rated; minimum

D. maximum rated; maximum rated

**USNRC GENERIC FUNDAMENTALS EXAMINATION
SEPTEMBER 2009 BWR--FORM A**

QUESTION: 12

A single-speed centrifugal pump is needed to supply river water to a storage facility. The pump must be capable of providing a very high flow rate at a low discharge pressure. Which one of the following types of centrifugal pumps is best suited for this application?

- A. Single-stage, axial flow
- B. Single-stage, radial flow
- C. Multiple-stage, axial flow
- D. Multiple-stage, radial flow

QUESTION: 13

Water enters a positive displacement pump at 50 psig and 90°F. What is the available net positive suction head for the pump?

- A. 80 feet
- B. 114 feet
- C. 133 feet
- D. 148 feet

**USNRC GENERIC FUNDAMENTALS EXAMINATION
SEPTEMBER 2009 BWR--FORM A**

QUESTION: 14

Which one of the following is a characteristic of a typical ac induction motor that causes starting current to be greater than running current?

- A. The rotor field induces an opposing voltage in the stator that is proportional to rotor speed.
- B. After the motor starts, resistors are added to the electrical circuit to limit the running current.
- C. A large amount of starting current is required to initially establish the rotating magnetic field.
- D. The rotor does not develop maximum induced current flow until it has achieved synchronous speed.

QUESTION: 15

A main generator is operating normally and connected to an infinite power grid with the following initial generator parameters:

Terminal Voltage:	22 KV
Frequency:	60 Hertz
Load--Real:	575 MW
Load--Reactive:	100 MVAR (in)
Power Factor:	0.985

Which one of the following contains a combination of normal adjustments to the main generator voltage regulator and speed control setpoints such that each adjustment will cause the main generator to operate at a power factor closer to 1.0. (Assume that generator power factor remains less than 1.0.)

- | | <u>Voltage
Setpoint</u> | <u>Speed
Setpoint</u> |
|----|-----------------------------|---------------------------|
| A. | Increase | Increase |
| B. | Increase | Decrease |
| C. | Decrease | Increase |
| D. | Decrease | Decrease |

**USNRC GENERIC FUNDAMENTALS EXAMINATION
SEPTEMBER 2009 BWR--FORM A**

QUESTION: 16

The discharge valve for a large operating centrifugal pump should be positioned slowly to minimize the...

- A. potential for causing water hammer.
- B. change in available net positive suction head.
- C. mechanical wear on the valve seat and stem packing.
- D. differential pressure stress exerted on the valve disk and stem.

**USNRC GENERIC FUNDAMENTALS EXAMINATION
SEPTEMBER 2009 BWR--FORM A**

QUESTION: 17

Refer to the drawing of an operating lube oil heat exchanger (see figure below).

If deposits accumulate on the outside of the cooling water tubes, cooling water outlet temperature will _____ and oil outlet temperature will _____. (Assume oil and cooling water inlet temperatures and flow rates remain the same.)

- A. increase; decrease
- B. increase; increase
- C. decrease; decrease
- D. decrease; increase

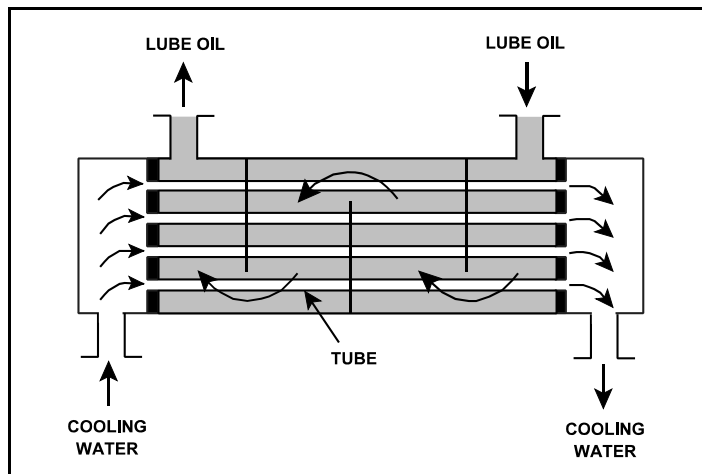

**USNRC GENERIC FUNDAMENTALS EXAMINATION
SEPTEMBER 2009 BWR--FORM A**

QUESTION: 18

During normal nuclear power plant operation, why does air entry into the main condenser reduce the thermodynamic efficiency of the steam cycle?

- A. The enthalpy of the low pressure turbine exhaust increases.
- B. The condensate subcooling in the main condenser decreases.
- C. The rate of steam flow through the main turbine increases.
- D. The air mixes with the steam and enters the condensate.

QUESTION: 19

The purpose of a mixed-bed demineralizer is to...

- A. raise the conductivity of water with little effect on pH.
- B. reduce the conductivity of water with little effect on pH.
- C. increase the pH of water by reducing the number of positively charged ions in it.
- D. decrease the pH of water by increasing the number of negatively charged ions in it.

**USNRC GENERIC FUNDAMENTALS EXAMINATION
SEPTEMBER 2009 BWR--FORM A**

QUESTION: 20

The cation exchange resin in a mixed-bed demineralizer releases desirable _____ ions into solution while removing undesirable _____ ions from solution.

- A. negative; negative
- B. negative; positive
- C. positive; negative
- D. positive; positive

**USNRC GENERIC FUNDAMENTALS EXAMINATION
SEPTEMBER 2009 BWR--FORM A**

QUESTION: 21

Refer to the drawing of a typical valve control circuit for a 480 VAC motor-operated valve (see figure below).

The valve is currently open with the contact configuration as shown. If the S1 pushbutton is depressed, the valve will _____ and when the S1 pushbutton is subsequently released, the valve will _____.

- A. remain open; remain open
- B. close; remain closed
- C. remain open; close
- D. close; open

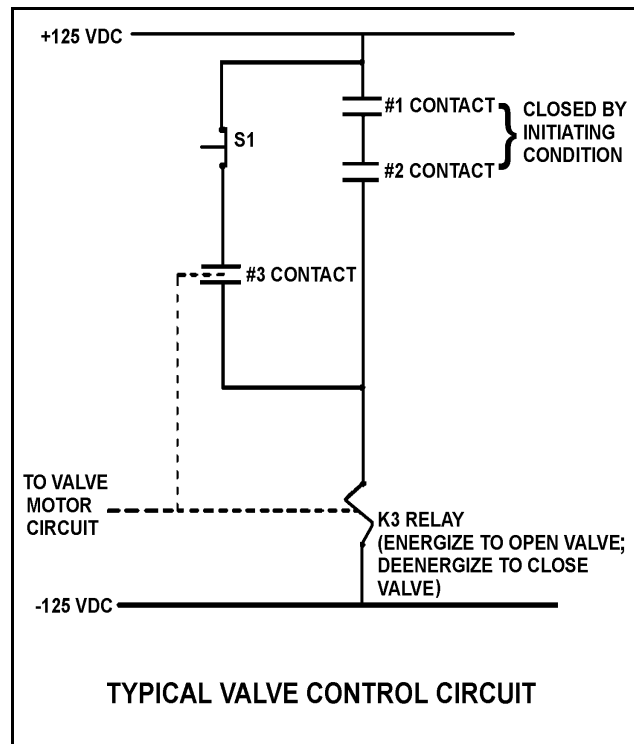

**USNRC GENERIC FUNDAMENTALS EXAMINATION
SEPTEMBER 2009 BWR--FORM A**

QUESTION: 22

Refer to the simplified drawing of an electrical distribution system (see figure below).

The high voltage side of each step-down transformer has a remote-operated disconnect to allow transformer maintenance while keeping the other transformers in service. The control circuit for each disconnect is position-interlocked with the associated MCC feeder breaker.

Which one of the following describes the purpose served by the interlock?

- A. Prevent damage to the disconnect.
- B. Prevent damage to the transformer.
- C. Prevent damage to the feeder breaker.
- D. Prevent damage to the 480V MCC.

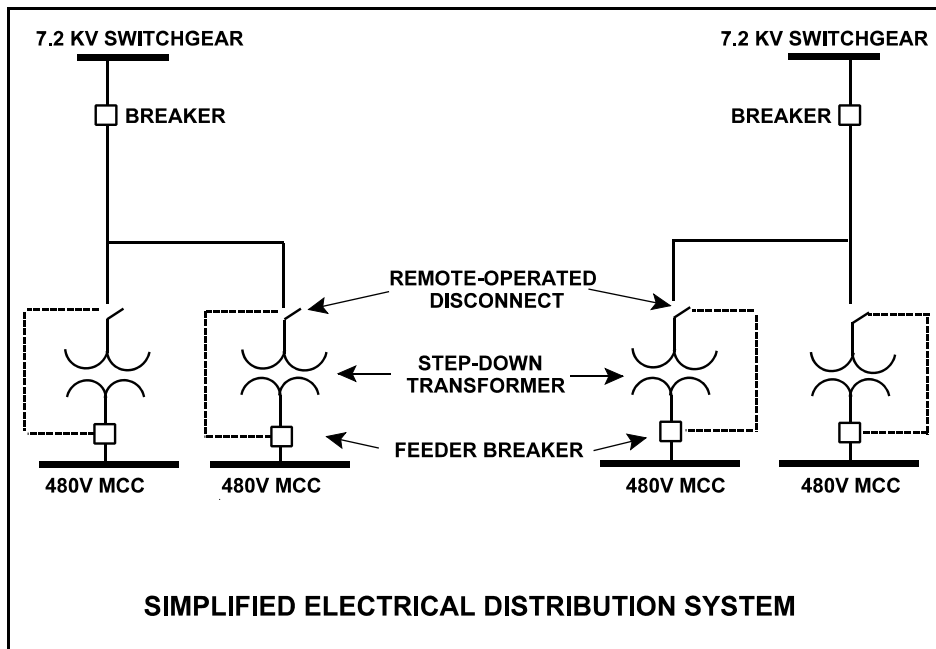

**USNRC GENERIC FUNDAMENTALS EXAMINATION
SEPTEMBER 2009 BWR--FORM A**

QUESTION: 23

Which one of the following conditions will increase the amount of neutron moderation in a nuclear reactor operating at 50% power?

- A. Increasing moderator temperature
- B. Reducing feedwater inlet temperature
- C. Reducing reactor vessel pressure
- D. Reducing reactor recirculation system flow rate

QUESTION: 24

Which one of the following is a reason for installing excess reactivity (K_{excess}) in a reactor core?

- A. To compensate for the conversion of U-238 to Pu-239 over core life.
- B. To compensate for burnout of Xe-135 and Sm-149 during power changes.
- C. To ensure the fuel temperature coefficient remains negative throughout core life.
- D. To compensate for the negative reactivity added by the power coefficient during a power increase.

**USNRC GENERIC FUNDAMENTALS EXAMINATION
SEPTEMBER 2009 BWR--FORM A**

QUESTION: 25

A small amount of positive reactivity is added to a critical reactor in the source range. The amount of reactivity added is much less than the core effective delayed neutron fraction.

Which one of the following will have a significant effect on the magnitude of the stable reactor period achieved for this reactivity addition while the reactor is in the source range?

- A. Moderator temperature coefficient
- B. Fuel temperature coefficient
- C. Prompt neutron lifetime
- D. Effective decay constant

QUESTION: 26

When compared to the beginning of a fuel cycle, the moderator temperature coefficient at 100 percent power near the end of a fuel cycle (EOC) is...

- A. more negative, because a larger fraction of the neutron flux will be absorbed by the control rods following a given moderator temperature increase.
- B. less negative, because a smaller fraction of the neutron flux will be absorbed by the control rods following a given moderator temperature increase.
- C. more negative, because a larger fraction of the neutron flux will leak out of the core following a given moderator temperature increase.
- D. less negative, because a smaller fraction of the neutron flux will leak out of the core following a given moderator temperature increase.

**USNRC GENERIC FUNDAMENTALS EXAMINATION
SEPTEMBER 2009 BWR--FORM A**

QUESTION: 27

Which one of the following describes why most power is produced in the lower half of a reactor core (versus the upper half) that has been operating at 100% power for several weeks near the beginning of a fuel cycle?

- A. Xenon concentration is higher in the upper half of the core.
- B. The moderator-to-fuel ratio is higher in the upper half of the core.
- C. Control rods are adding more negative reactivity in the upper half of the core.
- D. The void coefficient is adding more negative reactivity in the upper half of the core.

QUESTION: 28

A control rod, initially at position 06, is withdrawn three notches. After withdrawal, the control rod is classified as a _____ rod; and the blade tip for this control rod is positioned 36 inches from the _____ position.

- A. deep; fully inserted
- B. deep; fully withdrawn
- C. shallow; fully inserted
- D. shallow; fully withdrawn

**USNRC GENERIC FUNDAMENTALS EXAMINATION
SEPTEMBER 2009 BWR--FORM A**

QUESTION: 29

The total amount of reactivity added by a control rod position change from a reference height to any other rod height is called...

- A. differential rod worth.
- B. excess reactivity.
- C. integral rod worth.
- D. reference reactivity.

QUESTION: 30

Reactor power is increased from 50% to 60% in 1 hour. The most significant contributor to the initial change in xenon-135 reactivity is the increase in xenon-135...

- A. production from iodine decay.
- B. production from fission.
- C. absorption of neutrons.
- D. decay to cesium.

**USNRC GENERIC FUNDAMENTALS EXAMINATION
SEPTEMBER 2009 BWR--FORM A**

QUESTION: 31

A nuclear reactor is initially operating at 100% power with equilibrium core xenon-135. Power is decreased to 50% over a one hour period. No subsequent operator actions are taken.

Considering only the reactivity effects of core xenon-135 changes, which one of the following describes reactor power 10 hours after the power change is completed?

- A. Less than 50% and decreasing slowly.
- B. Less than 50% and increasing slowly.
- C. Greater than 50% and decreasing slowly.
- D. Greater than 50% and increasing slowly.

QUESTION: 32

Which one of the following is not a function performed by burnable poisons in an operating nuclear reactor?

- A. Provide neutron flux shaping.
- B. Provide more uniform power density.
- C. Offset the effects of control rod burnout.
- D. Allow higher fuel enrichment of initial core load.

**USNRC GENERIC FUNDAMENTALS EXAMINATION
SEPTEMBER 2009 BWR--FORM A**

QUESTION: 33

A nuclear power plant was operating at steady-state 100% power near the end of a fuel cycle when a reactor scram occurred. Reactor pressure is currently being maintained at 600 psig in anticipation of commencing a reactor startup.

Four hours after the scram, with reactor pressure still at 600 psig, which one of the following will cause the fission rate in the reactor core to increase?

- A. The operator fully withdraws the first group of control rods.
- B. Reactor vessel pressure is allowed to increase by 20 psig.
- C. Reactor coolant temperature is allowed to increase by 3 °F.
- D. An additional two hours are allowed to pass with no other changes in plant parameters.

QUESTION: 34

A subcritical nuclear reactor has an initial source range count rate of 2.0×10^5 cps with a core K_{eff} of 0.98. Positive reactivity is added to the core until a stable count rate of 5.0×10^5 cps is achieved. What is the new K_{eff} ?

- A. 0.984
- B. 0.988
- C. 0.992
- D. 0.996

**USNRC GENERIC FUNDAMENTALS EXAMINATION
SEPTEMBER 2009 BWR--FORM A**

QUESTION: 35

A nuclear reactor is being started up from cold shutdown conditions and currently has a stable positive 100-second reactor period in the intermediate range. Assuming no operator action is taken that affects reactivity, which one of the following describes how reactor period will respond?

- A. Remain constant until void production begins in the core.
- B. Remain constant until saturation temperature is reached in the core.
- C. Increase to infinity when heat production in the core exceeds ambient heat loss.
- D. Decrease to zero as the fuel temperature increase adds negative reactivity to the core.

QUESTION: 36

A nuclear power plant is initially operating steady-state at 50% power when a steam line break occurs that releases a constant 5% of rated steam flow. Assume no operator or protective actions occur, automatic pressure control returns reactor pressure to its value prior to the break, and feedwater injection temperature remains the same.

How will reactor power respond to the steam line break?

- A. Decrease and stabilize at a lower power level.
- B. Increase and stabilize at a higher power level.
- C. Decrease at first, then increase and stabilize near the initial power level.
- D. Increase at first, then decrease and stabilize near the initial power level.

**USNRC GENERIC FUNDAMENTALS EXAMINATION
SEPTEMBER 2009 BWR--FORM A**

QUESTION: 37

Refer to the drawing of four identical tank differential pressure level detectors (see figure below).

The tanks are identical and are presently at 2 psig overpressure, 60°F, and the same constant water level. They are located within a sealed containment structure that is being maintained at atmospheric pressure. All level detectors have been calibrated and are producing the same level indication. A ventilation malfunction causes the containment structure pressure to decrease to 13 psia.

Which level detectors will produce the highest indication?

- A. 1 and 2
- B. 3 and 4
- C. 1 and 4
- D. 2 and 3

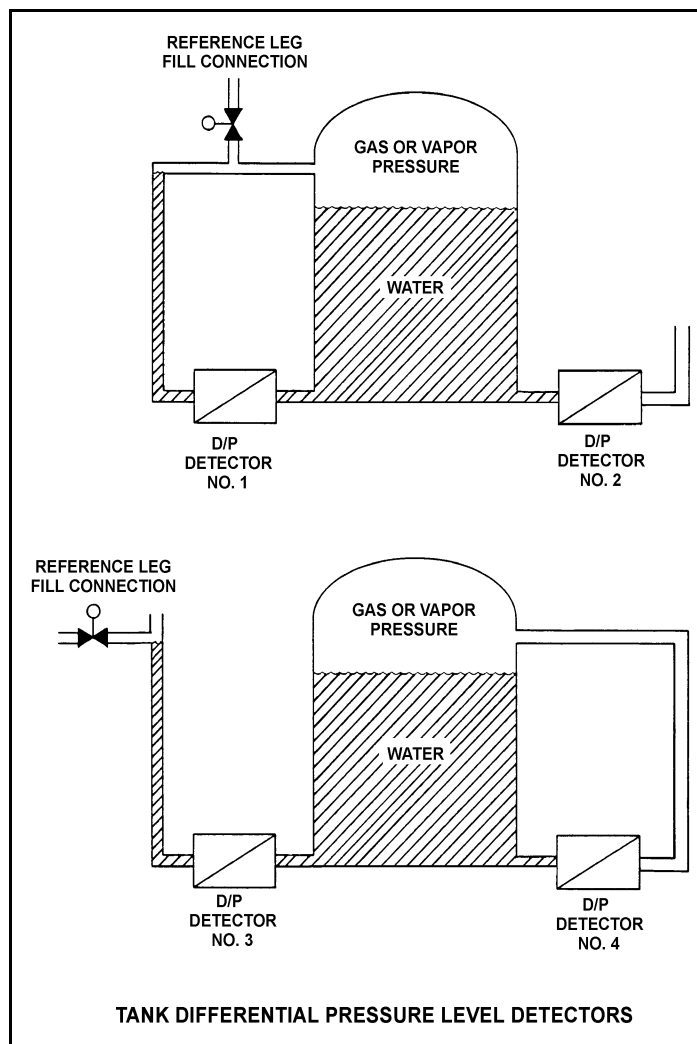

**USNRC GENERIC FUNDAMENTALS EXAMINATION
SEPTEMBER 2009 BWR--FORM A**

QUESTION: 38

Saturated steam enters a frictionless convergent-divergent nozzle with the following parameters:

Pressure = 850 psia

Velocity = 10 ft/sec

The steam at the throat of the nozzle has a subsonic velocity of 950 ft/sec.

Given that nozzles convert enthalpy to kinetic energy, and assuming no heat transfer to or from the nozzle, what is the enthalpy of the steam at the throat of the nozzle?

- A. 1,162 Btu/lbm
- B. 1,171 Btu/lbm
- C. 1,180 Btu/lbm
- D. 1,189 Btu/lbm

QUESTION: 39

Which one of the following explains why condensation of the steam entering a main condenser creates a vacuum?

- A. The entropy of the steam increases.
- B. The entropy of the steam decreases.
- C. The specific volume of the steam increases.
- D. The specific volume of the steam decreases.

**USNRC GENERIC FUNDAMENTALS EXAMINATION
SEPTEMBER 2009 BWR--FORM A**

QUESTION: 40

If the moisture content of the steam supplied to a main turbine increases, (assume no change in steam pressure, condenser pressure, or control valve position) turbine work will...

- A. decrease, because the enthalpy of the steam being supplied to the turbine has decreased.
- B. decrease, because moist steam is more likely to leak between turbine stages.
- C. increase, because the enthalpy of the steam being supplied to the turbine has increased.
- D. increase, because moist steam is less likely to leak between turbine stages.

**USNRC GENERIC FUNDAMENTALS EXAMINATION
SEPTEMBER 2009 BWR--FORM A**

QUESTION: 41

Refer to the drawing of a centrifugal pump operating curve and system curve (see figure below).

Which one of the following determines the general shape of the curve from point C to point D?

- A. The frictional and throttling losses in the piping system as the system flow rate increases.
- B. The frictional losses between the pump impeller and its casing as the differential pressure (D/P) across the pump increases.
- C. The pump flow losses due to the decrease in available net positive suction head as the system flow rate increases.
- D. The pump flow losses due to back leakage through the clearances between the pump impeller and casing as the D/P across the pump increases.

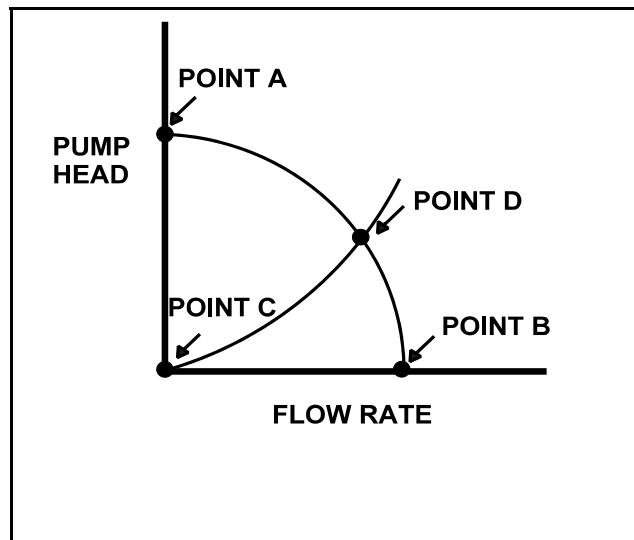

**USNRC GENERIC FUNDAMENTALS EXAMINATION
SEPTEMBER 2009 BWR--FORM A**

QUESTION: 42

A plant shutdown will be performed because of leakage from the main condenser cooling water system into the main condenser through a tube leak.

Given the following initial conditions:

- Main condenser pressure is 1.7 psia.
- Atmospheric pressure is 14.7 psia
- Main condenser cooling water pressure at the location of the tube leak is 18 psig.
- Cooling water leak rate into the main condenser is 80 gpm.

If the main condenser is brought to atmospheric pressure, with no changes to the main condenser cooling water system parameters, what will be the rate of cooling water leakage into the main condenser?

- A. 36 gpm
- B. 52 gpm
- C. 61 gpm
- D. 72 gpm

**USNRC GENERIC FUNDAMENTALS EXAMINATION
SEPTEMBER 2009 BWR--FORM A**

QUESTION: 43

A counter-flow heat exchanger is being used to cool the lube oil system for a main turbine and generator.

The main turbine and generator was initially operating at 100 percent load with the following stable heat exchanger conditions:

$$\begin{aligned}T_{\text{oil in}} &= 174^{\circ}\text{F} \\T_{\text{oil out}} &= 114^{\circ}\text{F} \\T_{\text{water in}} &= 85^{\circ}\text{F} \\T_{\text{water out}} &= 115^{\circ}\text{F}\end{aligned}$$

Main turbine and generator load was reduced, and the heat exchanger cooling water mass flow rate was decreased to one-half of its initial value, resulting in the following stable current conditions:

$$\begin{aligned}T_{\text{oil in}} &= 178^{\circ}\text{F} \\T_{\text{oil out}} &= 138^{\circ}\text{F} \\T_{\text{water in}} &= 85^{\circ}\text{F} \\T_{\text{water out}} &= ?\end{aligned}$$

Assume that the lube oil mass flow rate and the specific heats of both fluids did not change.

Which one of the following is the current cooling water outlet temperature?

- A. 115°F
- B. 125°F
- C. 135°F
- D. 145°F

**USNRC GENERIC FUNDAMENTALS EXAMINATION
SEPTEMBER 2009 BWR--FORM A**

QUESTION: 44

Which one of the following conditions must occur to sustain natural convection in a fluid system?

- A. Subcooling of the fluid
- B. A phase change in the fluid
- C. An enthalpy change in the fluid
- D. Radiative heat transfer to the fluid

QUESTION: 45

If the fission rate in a nuclear reactor core steadily increases, the mode of heat transfer that occurs immediately after the critical heat flux is reached is called...

- A. transition boiling.
- B. subcooled nucleate boiling.
- C. saturated nucleate boiling.
- D. stable film boiling.

**USNRC GENERIC FUNDAMENTALS EXAMINATION
SEPTEMBER 2009 BWR--FORM A**

QUESTION: 46

A nuclear reactor is operating at equilibrium 100% power. Assuming reactor coolant flow rate into the core region does not change, how will core bypass flow rate be affected during a reactor power decrease to 80%?

- A. Increase because greater two-phase flow resistance exists in the core at 80% power.
- B. Decrease because less two-phase flow resistance exists in the core at 80% power.
- C. Remain the same because core bypass flow rate is dependent only on reactor core flow rate.
- D. Remain the same because core bypass flow rate is unaffected by changes in reactor power.

QUESTION: 47

Which one of the following describes the basis for the 2,200°F maximum fuel clad temperature limit?

- A. 2,200°F is approximately 500°F below the fuel clad melting temperature.
- B. The material strength of zircaloy decreases rapidly at temperatures above 2,200°F.
- C. The rate of the zircaloy-water reaction becomes significant at temperatures above 2,200°F.
- D. At the normal operating pressure of the reactor vessel a clad temperature above 2,200°F indicates that the critical heat flux has been exceeded.

**USNRC GENERIC FUNDAMENTALS EXAMINATION
SEPTEMBER 2009 BWR--FORM A**

QUESTION: 48

Which of the following is indicated when the average planar linear heat generation rate (APLHGR)-to-maximum APLHGR ratio is less than 1?

- A. Linear heat generation rate (LHGR) limit has been exceeded.
- B. LHGR limit has not been exceeded.
- C. APLGHR limit has been exceeded.
- D. APLGHR limit has not been exceeded.

QUESTION: 49

During normal power operation a reactor pressure increase causes critical power to _____ because the latent heat of vaporization for the reactor coolant _____.

- A. increase; decreases
- B. decrease; decreases
- C. increase; increases
- D. decrease; increases

**USNRC GENERIC FUNDAMENTALS EXAMINATION
SEPTEMBER 2009 BWR--FORM A**

QUESTION: 50

Brittle fracture of a low-carbon steel is more likely to occur when the temperature of the steel is _____ the nil ductility temperature, and will normally occur when the applied stress is _____ the steel's yield strength (or yield stress).

- A. less than; less than
- B. less than; greater than
- C. greater than; less than
- D. greater than; greater than

*****FINAL ANSWER KEY *****

**SEPTEMBER 2009 NRC GENERIC FUNDAMENTALS EXAMINATION
BOILING WATER REACTOR - ANSWER KEY**

<u>FORM A</u>	<u>FORM B</u>	<u>ANS.</u>	<u>FORM A</u>	<u>FORM B</u>	<u>ANS.</u>
1	15	D	26	40	B or D
2	16	B	27	41	D
3	17	C	28	42	A
4	18	D	29	43	C
5	19	B	30	44	C
6	20	C	31	45	B
7	21	B	32	46	C
8	22	D	33	47	A
9	23	A	34	48	C
10	24	C	35	49	C
11	25	B	36	50	C
12	26	A	37	1	D
13	27	D	38	2	C
14	28	A	39	3	D
15	29	A	40	4	A
16	30	A	41	5	A
17	31	D	42	6	C
18	32	A	43	7	B
19	33	B	44	8	C
20	34	D	45	9	A
21	35	A or B	46	10	B
22	36	A	47	11	C
23	37	B	48	12	D
24	38	D	49	13	B
25	39	D	50	14	A