

**UNITED STATES NUCLEAR REGULATORY COMMISSION
PRESSURIZED WATER REACTOR GENERIC FUNDAMENTALS EXAMINATION
DECEMBER 2010--FORM A**

Please Print

Name: _____

Docket No.: _____

Facility: _____

Start Time: _____ Stop Time: _____

INSTRUCTIONS TO APPLICANT

Answer all the test items using the answer sheet provided, ensuring a single answer is marked for each test item. Each test item has equal point value. A score of at least 80 percent is required to pass this portion of the NRC operator licensing written examination. All examination materials will be collected 3 hours after the examination begins. This examination applies to a typical U.S. pressurized water reactor (PWR) nuclear power plant.

SECTION	QUESTIONS	% OF TOTAL	SCORE
COMPONENTS	1 - 22		
REACTOR THEORY	23 - 36		
THERMODYNAMICS	37 - 50		
TOTALS	50		

All work performed on this examination is my own. I have neither given nor received aid.

Applicant's Signature

**RULES AND INSTRUCTIONS FOR THE NRC
GENERIC FUNDAMENTALS EXAMINATION**

During the administration of this examination the following rules apply:

NOTE: The generic term "control rod" refers to the length of neutron absorber material that can be positioned by the operator to change core reactivity.

NOTE: Numerical answers are rounded to the nearest whole number unless otherwise indicated.

1. Print your name in the blank provided on the cover sheet of the examination.
2. Fill in your individual docket number.
3. Fill in the name of your facility.
4. Fill in your start and stop times at the appropriate times.
5. Two aids are provided for your use during the examination:
 - (1) An equations and conversions sheet contained within the examination copy, and
 - (2) Steam tables and Mollier Diagram provided by your proctor.
6. Place your answers on the answer sheet provided. Credit will only be given for answers properly marked on this sheet. Follow the instructions for filling out the answer sheet.
7. Scrap paper will be provided for calculations.
8. Cheating on the examination will result in the automatic forfeiture of this examination. Cheating could also result in severe penalties.
9. Restroom trips are limited. Only **one** examinee may leave the room at a time. In order to avoid the appearance or possibility of cheating, avoid all contact with anyone outside of the examination room.
10. After you have completed the examination, sign the statement on the cover sheet indicating that the work is your own and you have neither given nor received any assistance in completing the examination. Either pencil or pen may be used.
11. Turn in your examination materials, answer sheet on top, followed by the examination copy and the examination aids, e.g., steam tables, handouts, and scrap paper.
12. After turning in your examination materials, leave the examination area, as defined by the proctor. If after leaving you are found in the examination area while the examination is in progress, your examination may be forfeited.

**GENERIC FUNDAMENTALS EXAMINATION
EQUATIONS AND CONVERSIONS HANDOUT SHEET**

EQUATIONS

$$\dot{Q} = \dot{m}c_p\Delta T$$

$$\dot{Q} = \dot{m}\Delta h$$

$$\dot{Q} = UA\Delta T$$

$$\dot{Q} \propto \dot{m}_{\text{Nat Circ}}^3$$

$$\Delta T \propto \dot{m}_{\text{Nat Circ}}^2$$

$$K_{\text{eff}} = 1/(1 - \rho)$$

$$\rho = (K_{\text{eff}} - 1)/K_{\text{eff}}$$

$$\text{SUR} = 26.06/\tau$$

$$\tau = \frac{\bar{\beta}_{\text{eff}} - \rho}{\lambda_{\text{eff}} \rho}$$

$$\rho = \frac{\ell^*}{\tau} + \frac{\bar{\beta}_{\text{eff}}}{1 + \lambda_{\text{eff}} \tau}$$

$$\ell^* = 1 \times 10^{-4} \text{ sec}$$

$$\lambda_{\text{eff}} = 0.1 \text{ sec}^{-1} \text{ (for small positive } \rho \text{)}$$

$$\text{DRW} \propto \phi_{\text{tip}}^2 / \phi_{\text{avg}}^2$$

$$A = A_0 e^{-\lambda t}$$

$$P = P_0 10^{\text{SUR}(t)}$$

$$P = P_0 e^{(t/\tau)}$$

$$\text{CR}_{\text{S/D}} = S/(1 - K_{\text{eff}})$$

$$\text{CR}_1(1 - K_{\text{eff}1}) = \text{CR}_2(1 - K_{\text{eff}2})$$

$$1/M = \text{CR}_1/\text{CR}_x$$

$$A = \pi r^2$$

$$F = PA$$

$$\dot{m} = \rho A \bar{v}$$

$$\dot{W}_{\text{Pump}} = \dot{m}\Delta P v$$

$$P = IE$$

$$P_A = \sqrt{3} IE$$

$$P_T = \sqrt{3} IE \text{ pf}$$

$$P_R = \sqrt{3} IE \sin\theta$$

Thermal Efficiency = Net Work Out/Energy In

$$\frac{g(z_2 - z_1)}{g_c} + \frac{(\bar{v}_2^2 - \bar{v}_1^2)}{2g_c} + v(P_2 - P_1) + (u_2 - u_1) + (q - w) = 0$$

$$g_c = 32.2 \text{ lbm-ft/lbf-sec}^2$$

CONVERSIONS

$$1 \text{ Mw} = 3.41 \times 10^6 \text{ Btu/hr}$$

$$1 \text{ hp} = 2.54 \times 10^3 \text{ Btu/hr}$$

$$1 \text{ Btu} = 778 \text{ ft-lbf}$$

$$^{\circ}\text{C} = (5/9)(^{\circ}\text{F} - 32)$$

$$^{\circ}\text{F} = (9/5)(^{\circ}\text{C}) + 32$$

$$1 \text{ kg} = 2.21 \text{ lbm}$$

$$1 \text{ ft}^3_{\text{water}} = 7.48 \text{ gal}$$

$$1 \text{ gal}_{\text{water}} = 8.35 \text{ lbm}$$

$$1 \text{ Curie} = 3.7 \times 10^{10} \text{ dps}$$

**USNRC GENERIC FUNDAMENTALS EXAMINATION
DECEMBER 2010 PWR--FORM A**

QUESTION: 1

Subcooled water is flowing through a throttled valve in an open system. The initial steady state conditions for the throttled valve were as follows:

- Inlet pressure = 60 psia
- Outlet pressure = 44 psia
- Flow rate = 800 gpm

After four hours, the current steady state conditions for the throttled valve are as follows:

- Inlet pressure = 63 psia
- Outlet pressure = 54 psia
- Flow rate = 600 gpm

Which one of the following could be responsible for the difference between the initial and current conditions for the throttled valve?

- A. The throttled valve was opened farther.
- B. The throttled valve was closed farther.
- C. Another valve, located upstream of the throttled valve, was partially closed.
- D. Another valve, located downstream of the throttled valve, was partially closed.

**USNRC GENERIC FUNDAMENTALS EXAMINATION
DECEMBER 2010 PWR--FORM A**

QUESTION: 2

Compare a typical gate valve to a typical globe valve in the same application in an operating high-pressure cooling water system. If both valves are fully open, the gate valve will have a _____ pressure drop and is the better choice for _____ flow.

- A. higher; throttling
- B. higher; isolating
- C. lower; throttling
- D. lower; isolating

QUESTION: 3

Which one of the following will cause indicated volumetric flow rate to be lower than actual volumetric flow rate when using a differential pressure flow detector that is connected to a calibrated orifice?

- A. System pressure decreases.
- B. The orifice erodes over time.
- C. Debris becomes lodged in the orifice.
- D. A leak develops in the low pressure sensing line.

**USNRC GENERIC FUNDAMENTALS EXAMINATION
DECEMBER 2010 PWR--FORM A**

QUESTION: 4

Refer to the drawing of a tank differential pressure (D/P) level detection system (see figure below).

The water storage tank is 40 feet tall. The level detection system is calibrated to provide a level indication of 30 feet when the tank and reference leg levels are equal.

If the tank is completely filled with water, the tank level will indicate...

- A. less than 30 feet.
- B. 30 feet.
- C. greater than 30 feet, but less than 40 feet.
- D. 40 feet.

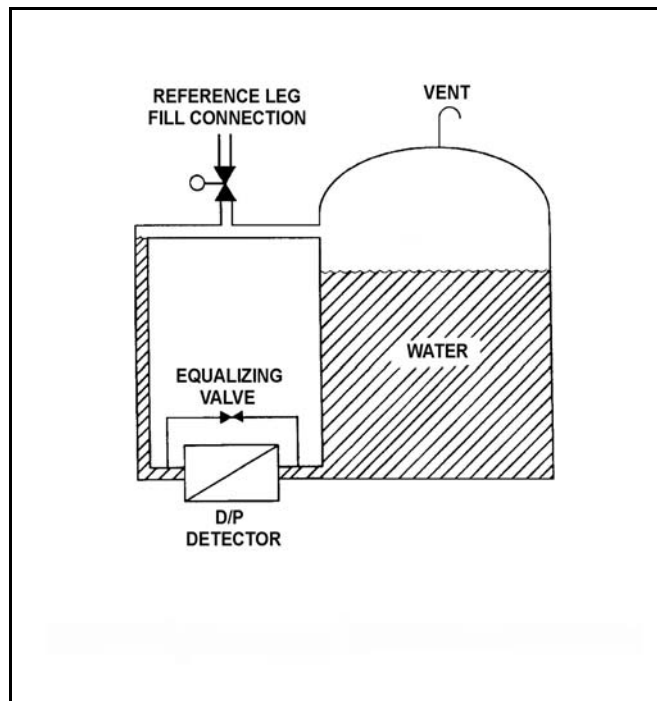

**USNRC GENERIC FUNDAMENTALS EXAMINATION
DECEMBER 2010 PWR--FORM A**

QUESTION: 5

If the pressure sensed by a bourdon tube increases, the curvature of the detector will _____ because the greater force is being applied to the _____ curve of the detector.

- A. increase; outer
- B. increase; inner
- C. decrease; outer
- D. decrease; inner

QUESTION: 6

Which one of the following is a characteristic of a resistance temperature detector but not a thermocouple?

- A. Sensing element is made from a single metal or alloy.
- B. Requires a reference junction for accurate temperature measurement.
- C. Extension leads made from relatively expensive metals or alloys are required for accurate temperature measurement.
- D. Temperature measurement relies on a sensor material property that varies directly with the change in the measured temperature.

**USNRC GENERIC FUNDAMENTALS EXAMINATION
DECEMBER 2010 PWR--FORM A**

QUESTION: 7

Refer to the drawing of a lube oil temperature control system (see figure below).

The temperature controller is a direct-acting proportional-integral controller with a gain of 1.0. All system temperatures are initially stable.

An increase in lube oil temperature causes the controller to open the temperature control valve (TCV) farther. What would be the effect on the TCV response if the controller gain was 2.0 rather than 1.0?

- A. The final TCV position would be half as far from its initial position.
- B. The final TCV position would be twice as far from its initial position.
- C. The final TCV position would be the same, but the TCV initially would travel a greater distance in response to the lube oil temperature change.
- D. The final TCV position would be the same, but the TCV initially would travel a shorter distance in response to the lube oil temperature change.

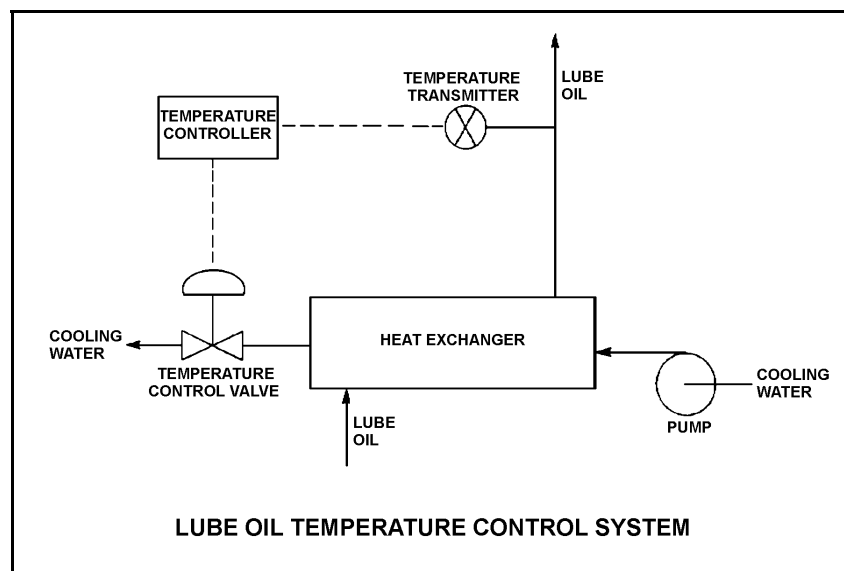

**USNRC GENERIC FUNDAMENTALS EXAMINATION
DECEMBER 2010 PWR--FORM A**

QUESTION: 8

The water level in a water storage tank is being controlled by an automatic bistable level controller. If water level increases to 70 percent, the controller bistable turns off to open a tank drain valve. When water level decreases to 60 percent, the controller bistable turns on to close the drain valve.

Which one of the following bistable symbols indicates the characteristics of the bistable used in the level controller?

- A. 1.
- B. 2.
- C. 3.
- D. 4.

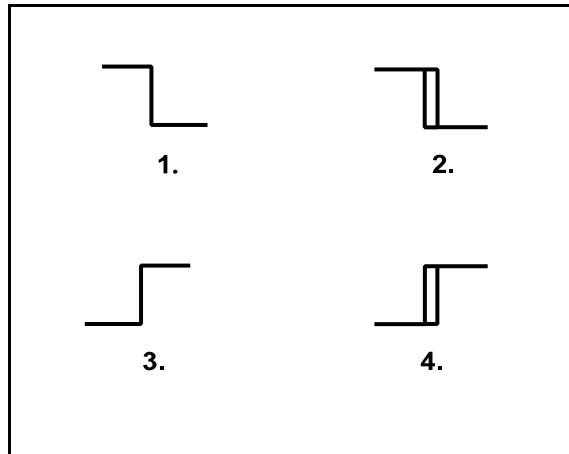

**USNRC GENERIC FUNDAMENTALS EXAMINATION
DECEMBER 2010 PWR--FORM A**

QUESTION: 9

What precaution must be observed when transferring a valve controller from the automatic mode to the manual mode of control?

- A. Ensure that a substantial deviation is established between the automatic and manual valve controller outputs.
- B. Ensure that the automatic and manual valve controller outputs are matched.
- C. Ensure that the automatic valve controller output is increasing before transferring to the manual mode of control.
- D. Ensure that the automatic valve controller output is decreasing before transferring to the manual mode of control.

QUESTION: 10

A radial flow centrifugal cooling water pump is driven by an ac induction motor. The pump can supply cooling water to several heat loads, all of which are in parallel alignment. The following pump conditions initially exist:

Pump motor current:	100 amps
Pump flow rate:	400 gpm
Pump suction temperature:	70°F

Four hours later, the motor is drawing 95 amps. Which one of the following could be responsible for the observed decrease in motor amps?

- A. The temperature of the cooling water being pumped decreased to 60°F with no change in pump flow rate.
- B. The temperature of the cooling water being pumped increased to 80°F with no change in pump flow rate.
- C. Cooling water flow was established to an additional heat load with no change in the temperature of the cooling water being pumped.
- D. Cooling water flow was isolated from an out-of-service heat load with no change in the temperature of the cooling water being pumped.

**USNRC GENERIC FUNDAMENTALS EXAMINATION
DECEMBER 2010 PWR--FORM A**

QUESTION: 11

Refer to the drawing of a steam condenser, hotwell, and condensate pump (see figure below).

Given the following:

- The eye of the pump impeller is located 6.0 feet below the bottom of the hotwell.
- The pump requires 10.0 ft-lbf/lbm of net positive suction head (NPSH).
- Condenser pressure is 1.2 psia.
- Hotwell water temperature is 90°F.
- Pump suction head losses are zero.

What is the minimum hotwell water level necessary to provide the required NPSH?

- A. 1.2 feet
- B. 2.8 feet
- C. 4.0 feet
- D. 5.2 feet

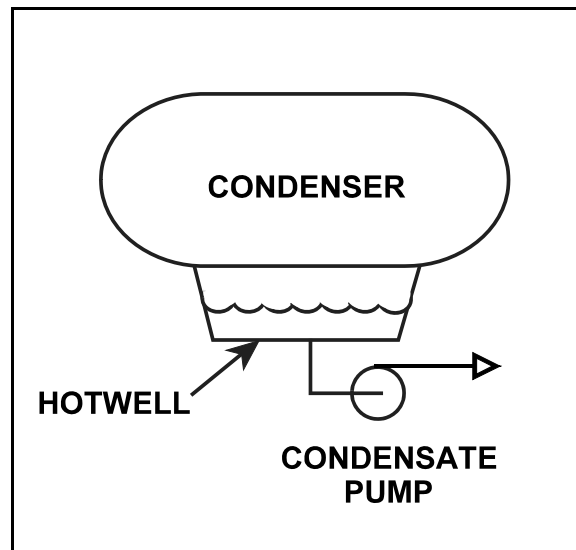

**USNRC GENERIC FUNDAMENTALS EXAMINATION
DECEMBER 2010 PWR--FORM A**

QUESTION: 12

Some large centrifugal pumps are started with their discharge valves closed to prevent...

- A. cavitation in the pump.
- B. lifting the discharge relief valve.
- C. loss of recirculation (miniflow).
- D. excessive current in the pump motor.

QUESTION: 13

A nuclear power plant is shut down with core decay heat being removed by the residual heat removal (RHR) system. The reactor coolant system (RCS) has been drained to a mid-loop water level of 20 inches in both the hot and cold legs. The operating RHR pump is taking suction from a hot leg and discharging 3,000 gpm to a cold leg.

A loss of RHR flow rate due to vortexing will become more likely if the water level in the hot leg is _____ by six inches or if the RHR system flow rate is _____ by 500 gpm.

- A. raised; decreased
- B. raised; increased
- C. lowered; decreased
- D. lowered; increased

**USNRC GENERIC FUNDAMENTALS EXAMINATION
DECEMBER 2010 PWR--FORM A**

QUESTION: 14

A 4,000 KW diesel generator (DG) and a 1,000 MW turbine generator (TG) at a nuclear power plant are connected to a power grid.

The following stable generator conditions initially exist:

<u>Diesel Generator</u>	<u>Turbine Generator</u>
700 KW	800 MW
200 KVAR (out)	100 MVAR (out)

Then, a malfunction occurs, causing the voltage regulator for the TG to slowly and continuously decrease the TG field excitation current. If no operator action is taken, the DG output current will _____ until a breaker trip separates the generators.

- A. increase continuously
- B. decrease continuously
- C. initially increase, and then decrease
- D. initially decrease, and then increase

QUESTION: 15

Frequent starts of large motors will result in overheating of the motor windings due to high current flow caused by...

- A. low electrical resistance of the motor windings.
- B. an electrical short circuit between the rotor and stator.
- C. high counter electromotive force at low rotor speeds.
- D. windage losses between the rotor and stator.

**USNRC GENERIC FUNDAMENTALS EXAMINATION
DECEMBER 2010 PWR--FORM A**

QUESTION: 16

Refer to the drawing of an operating lube oil heat exchanger (see figure below).

If mineral deposits accumulate on the inside of the cooling water tubes, cooling water outlet temperature will _____ and lube oil outlet temperature will _____. (Assume that the lube oil and cooling water inlet temperatures and flow rates do not change.)

- A. increase; decrease
- B. increase; increase
- C. decrease; decrease
- D. decrease; increase

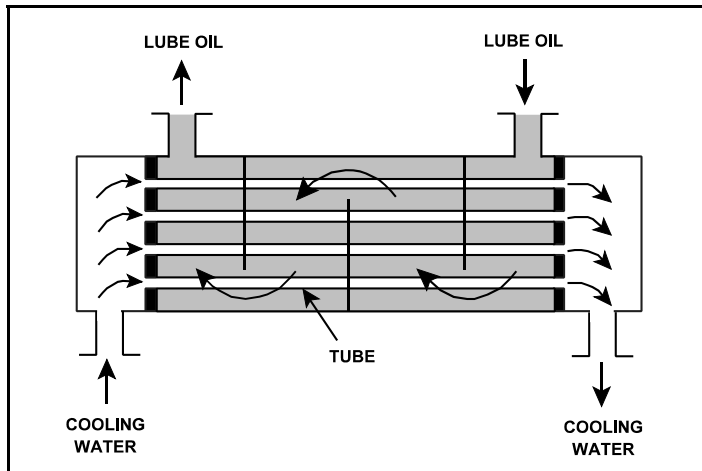

**USNRC GENERIC FUNDAMENTALS EXAMINATION
DECEMBER 2010 PWR--FORM A**

QUESTION: 17

Refer to the drawing of an operating cooling water system (see figure below).

Which one of the following effects would occur as a result of the failed tube in the heat exchanger?

- A. Level in the surge tank increases.
- B. Flow in the low pressure (LP) system reverses.
- C. Pressure in the low pressure (LP) system decreases.
- D. Low pressure (LP) fluid heat exchanger outlet temperature decreases.

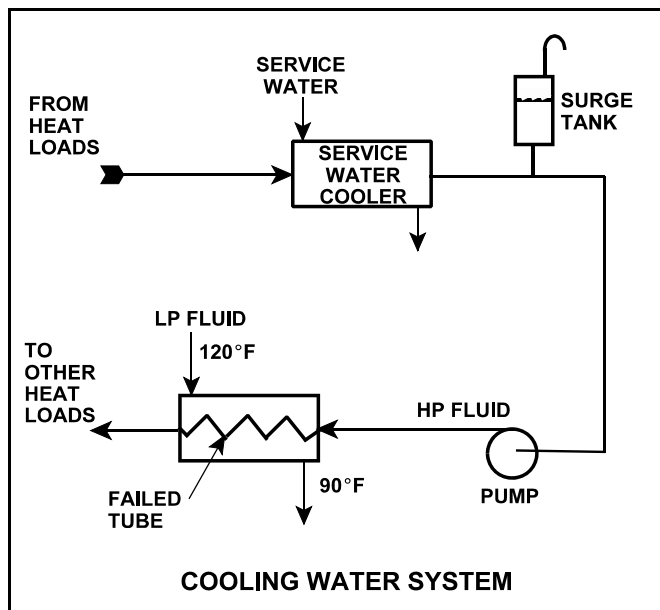

**USNRC GENERIC FUNDAMENTALS EXAMINATION
DECEMBER 2010 PWR--FORM A**

QUESTION: 18

A demineralizer is being used in a water purification system. How will the accumulation of suspended solids in the demineralizer affect the performance of the demineralizer?

- A. The rate of resin depletion will increase.
- B. The flow rate of water through the demineralizer will increase.
- C. The differential pressure across the demineralizer will decrease.
- D. The rate of unwanted ion removal from the system will decrease.

QUESTION: 19

The decontamination factor (also called the demineralization factor) of a condensate demineralizer has just been determined to be 50 based on conductivity measurements.

If condensate having a conductivity of 20 $\mu\text{mho/cm}$ is flowing into this demineralizer, which one of the following is the conductivity of the condensate at the outlet of the demineralizer?

- A. 0.4 $\mu\text{mho/cm}$
- B. 1.0 $\mu\text{mho/cm}$
- C. 4.0 $\mu\text{mho/cm}$
- D. 10.0 $\mu\text{mho/cm}$

**USNRC GENERIC FUNDAMENTALS EXAMINATION
DECEMBER 2010 PWR--FORM A**

QUESTION: 20

Which one of the following is an unsafe practice if performed when working on or near energized electrical equipment?

- A. Use insulated tools to prevent inadvertent contact with adjacent equipment.
- B. Cover exposed energized circuits with insulating material to prevent inadvertent contact.
- C. Attach a metal strap from your body to a nearby neutral ground to ensure that you are grounded.
- D. Have a person standing by with the ability to remove you from the equipment in the event of an emergency.

QUESTION: 21

When a typical 4,160 VAC breaker is racked to the "test" position, control power is _____ the breaker and the breaker is _____ the load.

- A. available to; connected to
- B. available to; isolated from
- C. removed from; connected to
- D. removed from; isolated from

**USNRC GENERIC FUNDAMENTALS EXAMINATION
DECEMBER 2010 PWR--FORM A**

QUESTION: 22

Given the following indications for an open 4,160 VAC breaker:

- The local OPEN/CLOSED mechanical flag indicates open.
- A breaker overcurrent trip flag is actuated on one phase.
- The line-side voltmeter indicates 4,160 VAC.
- The load-side voltmeter indicates 0 volts.

Assuming no operator actions were taken since the breaker opened, which one of the following could have caused the breaker to open?

- A. A ground fault caused an automatic breaker trip.
- B. A loss of control power caused an automatic breaker trip.
- C. An operator opened the breaker locally.
- D. An operator opened the breaker from a remote location.

QUESTION: 23

During a brief time interval in a typical commercial nuclear reactor operating at the beginning of a fuel cycle, 4.25×10^5 delayed neutrons were emitted.

Approximately how many prompt neutrons were emitted in the reactor during this same time interval?

- A. 1.5×10^6
- B. 6.5×10^6
- C. 1.5×10^7
- D. 6.5×10^7

**USNRC GENERIC FUNDAMENTALS EXAMINATION
DECEMBER 2010 PWR--FORM A**

QUESTION: 24

A nuclear power plant was initially operating at steady state 70 percent power near the middle of a fuel cycle when a control rod dropped into the core. Consider the following two possible operator responses:

Response 1: An operator adjusts the reactor coolant system (RCS) boron concentration to restore the initial reactor coolant temperatures.

Response 2: An operator withdraws some of the remaining control rods to restore the initial reactor coolant temperatures.

In a comparison between the two responses, which response, if any, will result in the greater available shutdown margin when the plant is stabilized at 70 percent power, and why?

- A. Response 1, because a smaller (than response 2) amount of positive reactivity will be added by the RCS cooldown that occurs immediately after a reactor trip.
- B. Response 2, because a larger (than response 1) amount of negative reactivity will be added by the control rods upon a reactor trip.
- C. The available SDM is the same for both responses because the plant is stabilized at the same initial steady state power level.
- D. The available SDM is the same for both responses because the same amount of positive reactivity is added in both responses.

**USNRC GENERIC FUNDAMENTALS EXAMINATION
DECEMBER 2010 PWR--FORM A**

QUESTION: 25

A nuclear reactor was stable at 80 percent power when the reactor operator withdrew control rods continuously for 2 seconds. Which one of the following affects the amount of “prompt jump” increase in reactor power for the control rod withdrawal?

- A. The duration of control rod withdrawal.
- B. The differential control rod worth.
- C. The total control rod worth.
- D. The magnitude of the fuel temperature coefficient.

QUESTION: 26

If the average temperature of a fuel pellet increases by 50°F, the microscopic cross-section for absorption of neutrons at a resonance energy of U-238 will _____; and the microscopic cross-sections for absorption of neutrons at energies that are slightly higher or lower than a U-238 resonance energy will _____.

- A. increase; increase
- B. increase; decrease
- C. decrease; increase
- D. decrease; decrease

**USNRC GENERIC FUNDAMENTALS EXAMINATION
DECEMBER 2010 PWR--FORM A**

QUESTION: 27

Given the following initial parameters:

Initial reactor coolant system boron concentration	= 600 ppm
Moderator temperature coefficient	= -0.015% $\Delta K/K$ per °F
Differential boron worth	= -0.010% $\Delta K/K$ per ppm

Which one of the following is the final reactor coolant boron concentration required to decrease average coolant temperature by 4°F. (Assume no change in control rod position or reactor/turbine power).

- A. 606 ppm
- B. 603 ppm
- C. 597 ppm
- D. 594 ppm

QUESTION: 28

A nuclear reactor has been taken critical following a refueling outage and is currently at the point of adding heat during a normal reactor startup. Which one of the following describes the change in core axial power distribution as reactor power is increased to five percent by control rod withdrawal?

- A. Shifts toward the bottom of the core.
- B. Shifts toward the top of the core.
- C. Shifts away from the center toward the top and bottom of the core.
- D. Shifts away from the top and bottom toward the center of the core.

**USNRC GENERIC FUNDAMENTALS EXAMINATION
DECEMBER 2010 PWR--FORM A**

QUESTION: 29

Why are control rod insertion limits established for power operation?

- A. To minimize the worth of a postulated dropped control rod.
- B. To maintain a negative moderator temperature coefficient in the reactor.
- C. To provide adequate shutdown margin after a reactor trip.
- D. To ensure sufficient positive reactivity is available to compensate for the existing power defect.

QUESTION: 30

A nuclear power plant is initially operating at steady state 100 percent power in the middle of a fuel cycle. The operators decrease main generator load while adding boric acid to the reactor coolant system (RCS) over a period of 30 minutes. At the end of this time period, reactor power is 70 percent and average reactor coolant temperature is 575°F. All control rods remain fully withdrawn and in manual control.

Considering only the reactivity effects of core xenon-135 changes, which one of the following describes the status of the average reactor coolant temperature 60 minutes after the power change is completed?

- A. 575°F and stable.
- B. Less than 575°F and increasing.
- C. Less than 575°F and decreasing.
- D. Less than 575°F and stable.

**USNRC GENERIC FUNDAMENTALS EXAMINATION
DECEMBER 2010 PWR--FORM A**

QUESTION: 31

After a reactor shutdown from equilibrium core xenon conditions, the maximum xenon -135 negative reactivity (height of the xenon peak) is _____ the pre-shutdown equilibrium power level.

- A. independent of
- B. directly proportional to
- C. inversely proportional to
- D. dependent on but not directly proportional to

QUESTION: 32

Just prior to a refueling outage, a nuclear power plant is operating at 100 percent power with a reactor coolant boron concentration of 50 ppm. After the refueling outage, the 100 percent power boron concentration is approximately 1,000 ppm.

Which one of the following is the primary reason for the large increase in full-power reactor coolant boron concentration?

- A. Reactivity from power defect at beginning of core life (BOL) is much greater than at end of core life (EOL).
- B. Differential boron worth at BOL is much less than at EOL.
[Inverse boron worth at BOL is much greater than at EOL.]
- C. The excess reactivity in the core at BOL is much greater than at EOL.
- D. The integral control rod worth at BOL is much less than at EOL.

**USNRC GENERIC FUNDAMENTALS EXAMINATION
DECEMBER 2010 PWR--FORM A**

QUESTION: 33

To predict critical control rod position prior to commencing a nuclear reactor startup, the operator must consider the amount of reactivity added by post-shutdown changes in...

- A. reactor coolant boron concentration, neutron flux level, and burnable poisons.
- B. neutron flux level, reactor coolant boron concentration, and control rod positions.
- C. control rod positions, core xenon-135 concentration, and reactor coolant temperature.
- D. reactor coolant temperature, burnable poisons, and core xenon-135 concentration.

QUESTION: 34

After taking critical data during a nuclear reactor startup, the operator establishes a stable 1 DPM startup rate to increase power to the point of adding heat (POAH). How much negative reactivity feedback must be added at the POAH to stop the power increase? (Assume that $\bar{\beta}_{\text{eff}} = 0.00579$.)

- A. 0.16% $\Delta K/K$
- B. 0.19% $\Delta K/K$
- C. 0.23% $\Delta K/K$
- D. 0.29% $\Delta K/K$

**USNRC GENERIC FUNDAMENTALS EXAMINATION
DECEMBER 2010 PWR--FORM A**

QUESTION: 35

A nuclear reactor is stable at the point of adding heat (POAH) with the average reactor coolant temperature at 550°F during a startup. Control rods are then withdrawn a few inches to increase steam generator steaming rate.

When the reactor stabilizes, reactor power will be _____ the POAH, and average reactor coolant temperature will be _____ 550°F.

- A. greater than; equal to
- B. greater than; greater than
- C. equal to; equal to
- D. equal to; greater than

QUESTION: 36

A nuclear power plant is operating at 90 percent power near the end of core life with manual rod control when a turbine control system malfunction opens the turbine control valves an additional 5 percent. Reactor power will initially...

- A. decrease because the rate of neutron absorption in the moderator initially increases.
- B. decrease because the rate of neutron absorption at U-238 resonant energies initially increases.
- C. increase because the rate of neutron absorption in the moderator initially decreases.
- D. increase because the rate of neutron absorption at U-238 resonant energies initially decreases.

**USNRC GENERIC FUNDAMENTALS EXAMINATION
DECEMBER 2010 PWR--FORM A**

QUESTION: 37

Refer to the drawing of four differential pressure level detectors (see figure below).

The tanks are identical and being maintained at 30 psia with a water level of 20 feet. They are surrounded by standard atmospheric pressure. The water temperatures in the tanks and reference legs are the same.

If each detector experiences a ruptured diaphragm, which detector(s) will cause indicated tank level to decrease? (Assume actual tank water level remains constant.)

- A. No. 1 only
- B. No. 2 only
- C. No. 1, 2, and 3
- D. No. 2, 3, and 4

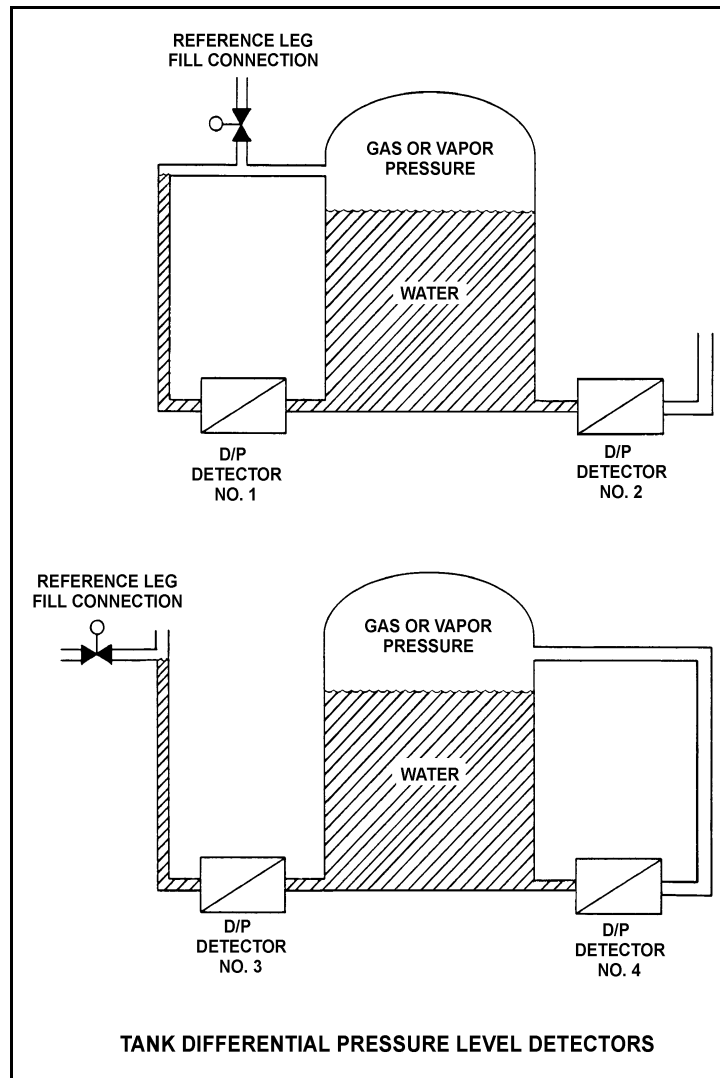

**USNRC GENERIC FUNDAMENTALS EXAMINATION
DECEMBER 2010 PWR--FORM A**

QUESTION: 38

Two identical pressurizers are connected to the same location on two identical reactor coolant systems operating at 1,000 psia. Pressurizer A volume contains 50 percent subcooled water (at 300°F) and 50 percent nitrogen. Pressurizer B volume contains 50 percent saturated water and 50 percent saturated steam.

Which one of the following explains which pressurizer will maintain the highest pressure during a sudden 10 percent liquid outsurge from each pressurizer?

- A. Pressurizer A due to the subcooled water resulting in a smaller amount of energy being lost during the outsurge.
- B. Pressurizer A due to the expansion characteristics of nitrogen being better than the expansion characteristics of saturated steam.
- C. Pressurizer B due to vaporizing of saturated water as pressure begins to decrease.
- D. Pressurizer B due to the expansion characteristics of saturated steam being better than the expansion characteristics of nitrogen.

QUESTION: 39

Saturated steam (100 percent quality) at 240 psia enters an ideal low pressure turbine and exhausts to a steam condenser at 1.0 psia. Compared to the entry conditions, the volumetric flow rate of the steam leaving the LP turbine will be about _____ times larger.

- A. 103
- B. 132
- C. 178
- D. 240

**USNRC GENERIC FUNDAMENTALS EXAMINATION
DECEMBER 2010 PWR--FORM A**

QUESTION: 40

Condensate is collecting in a main condenser hotwell at 90°F with a condenser pressure of 28 inches Hg vacuum. Which one of the following will improve steam cycle efficiency?

- A. Main condenser cooling water flow rate decreases by 5 percent with no change in condenser vacuum.
- B. Main condenser cooling water inlet temperature decreases by 10°F with no change in condenser vacuum.
- C. Main condenser vacuum decreases to 27 inches Hg due to buildup of noncondensable gases.
- D. Steam flow through the turbine decreases by 10 percent with no change in condenser vacuum.

QUESTION: 41

A nuclear power plant is initially operating at steady state 85 percent reactor power when extraction steam to a high-pressure feedwater heater is isolated. Main generator load is returned to its initial value. When the plant stabilizes, reactor power will be _____ than 85 percent, and overall plant thermal efficiency will be _____.

- A. greater; lower
- B. greater; higher
- C. less; lower
- D. less; higher

**USNRC GENERIC FUNDAMENTALS EXAMINATION
DECEMBER 2010 PWR--FORM A**

QUESTION: 42

A centrifugal water pump is being returned to service after maintenance. However, the operator failed to vent the pump.

Compared to normal pump operating conditions, after the pump is started the operator will see a _____ flow rate and a _____ discharge head.

- A. higher; lower
- B. higher; higher
- C. lower; lower
- D. lower; higher

QUESTION: 43

A four-loop nuclear power plant uses four identical reactor coolant pumps (RCPs) to supply reactor coolant flow through the reactor vessel. The plant is currently operating at 20 percent power with all RCPs in operation.

Which one of the following describes the stable RCS flow rate through the reactor vessel following the trip of one RCP? (Assume that no operator actions are taken and the reactor does not trip.)

- A. Less than 75 percent of the original flow rate.
- B. Exactly 75 percent of the original flow rate.
- C. Greater than 75 percent of the original flow rate.
- D. Unpredictable without pump curves for the RCPs.

**USNRC GENERIC FUNDAMENTALS EXAMINATION
DECEMBER 2010 PWR--FORM A**

QUESTION: 44

The power range nuclear instruments have been adjusted to 100 percent based on a heat balance calculation. Which one of the following will result in indicated reactor power being lower than actual reactor power?

- A. The feed water temperature used in the heat balance calculation was 20°F higher than actual feed water temperature.
- B. The reactor coolant pump heat input term was omitted from the heat balance calculation.
- C. The feed water flow rate used in the heat balance calculation was 10 percent higher than actual flow rate.
- D. The steam pressure used in the heat balance calculation was 50 psi lower than actual steam pressure.

QUESTION: 45

As heat is transferred to water adjacent to a heating surface, many factors influence steam bubble formation. Which one of the following characteristics will enhance steam bubble formation?

- A. Chemicals dissolved in the water
- B. The absence of ionizing radiation exposure to the water
- C. A highly polished heat transfer surface with minimal scratches or cavities
- D. The presence of gases dissolved in the water

**USNRC GENERIC FUNDAMENTALS EXAMINATION
DECEMBER 2010 PWR--FORM A**

QUESTION: 46

A small increase in ΔT (at the fuel clad-to-coolant interface) causes increased steam blanketing and a reduction in heat flux. This describes which type of boiling?

- A. Subcooled boiling
- B. Nucleate boiling
- C. Partial film boiling
- D. Total film boiling

QUESTION: 47

During a plant cooldown and depressurization with forced circulation, reactor coolant system (RCS) loop flow and reactor coolant pump (RCP) current indications become erratic. These abnormal indications are most likely caused by...

- A. RCP cavitation.
- B. RCP runout.
- C. RCS loop water hammer.
- D. RCS hot leg saturation.

**USNRC GENERIC FUNDAMENTALS EXAMINATION
DECEMBER 2010 PWR--FORM A**

QUESTION: 48

Refer to the drawing of a section of pipe with subcooled water flowing through it (see figure below).

Given:

Pressure at P_1 is 30 psig.

Pressure at P_2 is 32 psig.

Pressure change due to change in velocity is 2 psig.

Pressure change due to change in elevation is 2 psig.

The pressure decrease due to friction head loss between P_1 and P_2 is _____; and the direction of flow is from _____.

- A. 2 psig; left to right
- B. 2 psig; right to left
- C. 6 psig; left to right
- D. 6 psig; right to left

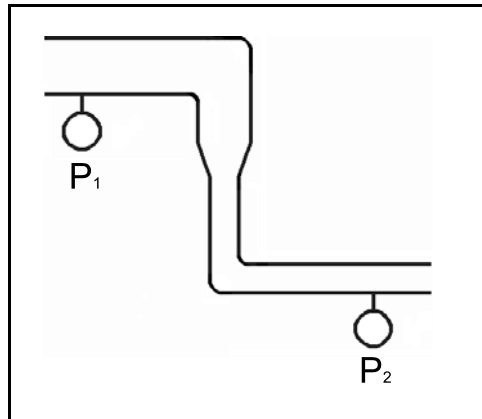

**USNRC GENERIC FUNDAMENTALS EXAMINATION
DECEMBER 2010 PWR--FORM A**

QUESTION: 49

The 2,200°F maximum peak fuel cladding temperature limit is imposed because...

- A. 2,200°F is approximately 500°F below the fuel cladding melting temperature.
- B. the rate of the zircaloy-steam reaction increases significantly at temperatures above 2,200°F.
- C. any cladding temperature higher than 2,200°F correlates to a fuel centerline temperature above the fuel melting point.
- D. the thermal conductivity of zircaloy decreases rapidly at temperatures above 2,200°F.

QUESTION: 50

Two identical nuclear reactors have been in operation for the last 10 years. Reactor A has experienced 40 heatup/cooldown cycles with an average power capacity of 50 percent. Reactor B has experienced 30 heatup/cooldown cycles with an average power capacity of 60 percent.

Which reactor will have the lowest reactor vessel nil-ductility transition temperature?

- A. Reactor A due to the lower average power capacity.
- B. Reactor A due to the greater number of heatup/cooldown cycles.
- C. Reactor B due to the higher average power capacity.
- D. Reactor B due to the fewer number of heatup/cooldown cycles.

***** FINAL ANSWER KEY *****

**DECEMBER 2010 NRC GENERIC FUNDAMENTALS EXAMINATION
PRESSURIZED WATER REACTOR - ANSWER KEY**

<u>FORM A</u>	<u>FORM B</u>	<u>ANS.</u>	<u>FORM A</u>	<u>FORM B</u>	<u>ANS.</u>
1	15	D	26	40	C
2	16	D	27	41	A
3	17	B	28	42	B
4	18	B	29	43	C
5	19	C	30	44	C
6	20	A	31	45	D
7	21	C	32	46	C
8	22	B	33	47	C
9	23	B	34	48	A
10	24	D	35	49	B
11	25	B	36	50	D
12	26	D	37	1	D
13	27	D	38	2	C
14	28	A	39	3	B
15	29	A	40	4	A
16	30	D	41	5	A
17	31	D	42	6	C
18	32	D	43	7	C
19	33	A	44	8	A
20	34	C	45	9	D
21	35	B	46	10	C
22	36	A	47	11	A
23	37	D	48	12	B
24	38	B	49	13	B
25	39	B	50	14	A