

**UNITED STATES NUCLEAR REGULATORY COMMISSION
PRESSURIZED WATER REACTOR GENERIC FUNDAMENTALS EXAMINATION
DECEMBER 2011--FORM A**

Please Print

Name: _____

Docket No.: _____

Facility: _____

Start Time: _____ Stop Time: _____

INSTRUCTIONS TO APPLICANT

Answer all the test items using the answer sheet provided, ensuring a single answer is marked for each test item. Each test item has equal point value. A score of at least 80 percent is required to pass this portion of the NRC operator licensing written examination. All examination materials will be collected 3 hours after the examination begins. This examination applies to a typical U.S. pressurized water reactor (PWR) nuclear power plant.

SECTION	QUESTIONS	% OF TOTAL	SCORE
COMPONENTS	1 - 22		
REACTOR THEORY	23 - 36		
THERMODYNAMICS	37 - 50		
TOTALS	50		

All work performed on this examination is my own. I have neither given nor received aid.

Applicant's Signature

**RULES AND INSTRUCTIONS FOR THE NRC
GENERIC FUNDAMENTALS EXAMINATION**

During the administration of this examination the following rules apply:

NOTE: The generic term "control rod" refers to the length of neutron absorber material that can be positioned by the operator to change core reactivity.

NOTE: Numerical answers are rounded to the nearest whole number unless otherwise indicated.

1. Print your name in the blank provided on the cover sheet of the examination.
2. Fill in your individual docket number.
3. Fill in the name of your facility.
4. Fill in your start and stop times at the appropriate times.
5. Two aids are provided for your use during the examination:
 - (1) An equations and conversions sheet contained within the examination copy, and
 - (2) Steam tables and Mollier Diagram provided by your proctor.
6. Place your answers on the answer sheet provided. Credit will only be given for answers properly marked on this sheet. Follow the instructions for filling out the answer sheet.
7. Scrap paper will be provided for calculations.
8. Cheating on the examination will result in the automatic forfeiture of this examination. Cheating could also result in severe penalties.
9. Restroom trips are limited. Only **one** examinee may leave the room at a time. In order to avoid the appearance or possibility of cheating, avoid all contact with anyone outside of the examination room.
10. After you have completed the examination, sign the statement on the cover sheet indicating that the work is your own and you have neither given nor received any assistance in completing the examination. Either pencil or pen may be used.
11. Turn in your examination materials, answer sheet on top, followed by the examination copy and the examination aids, e.g., steam tables, handouts, and scrap paper.
12. After turning in your examination materials, leave the examination area, as defined by the proctor. If after leaving you are found in the examination area while the examination is in progress, your examination may be forfeited.

**GENERIC FUNDAMENTALS EXAMINATION
EQUATIONS AND CONVERSIONS HANDOUT SHEET**

EQUATIONS

$$\dot{Q} = \dot{m}c_p\Delta T$$

$$\dot{Q} = \dot{m}\Delta h$$

$$\dot{Q} = UA\Delta T$$

$$\dot{Q} \propto \dot{m}_{\text{Nat Circ}}^3$$

$$\Delta T \propto \dot{m}_{\text{Nat Circ}}^2$$

$$K_{\text{eff}} = 1/(1 - \rho)$$

$$\rho = (K_{\text{eff}} - 1)/K_{\text{eff}}$$

$$\text{SUR} = 26.06/\tau$$

$$\tau = \frac{\bar{\beta}_{\text{eff}} - \rho}{\lambda_{\text{eff}} \rho}$$

$$\rho = \frac{\ell^*}{\tau} + \frac{\bar{\beta}_{\text{eff}}}{1 + \lambda_{\text{eff}} \tau}$$

$$\ell^* = 1 \times 10^{-4} \text{ sec}$$

$$\lambda_{\text{eff}} = 0.1 \text{ sec}^{-1} \text{ (for small positive } \rho \text{)}$$

$$\text{DRW} \propto \phi_{\text{tip}}^2 / \phi_{\text{avg}}^2$$

$$A = A_0 e^{-\lambda t}$$

$$P = P_0 10^{\text{SUR}(t)}$$

$$P = P_0 e^{(t/\tau)}$$

$$\text{CR}_{\text{S/D}} = S/(1 - K_{\text{eff}})$$

$$\text{CR}_1(1 - K_{\text{eff}1}) = \text{CR}_2(1 - K_{\text{eff}2})$$

$$1/M = \text{CR}_1/\text{CR}_x$$

$$A = \pi r^2$$

$$F = PA$$

$$\dot{m} = \rho A \bar{v}$$

$$\dot{W}_{\text{Pump}} = \dot{m}\Delta P v$$

$$P = IE$$

$$P_A = \sqrt{3} IE$$

$$P_T = \sqrt{3} IE \text{ pf}$$

$$P_R = \sqrt{3} IE \sin\theta$$

Thermal Efficiency = Net Work Out/Energy In

$$\frac{g(z_2 - z_1)}{g_c} + \frac{(\bar{v}_2^2 - \bar{v}_1^2)}{2g_c} + v(P_2 - P_1) + (u_2 - u_1) + (q - w) = 0$$

$$g_c = 32.2 \text{ lbm-ft/lbf-sec}^2$$

CONVERSIONS

$$1 \text{ Mw} = 3.41 \times 10^6 \text{ Btu/hr}$$

$$1 \text{ hp} = 2.54 \times 10^3 \text{ Btu/hr}$$

$$1 \text{ Btu} = 778 \text{ ft-lbf}$$

$$^\circ\text{C} = (5/9)(^\circ\text{F} - 32)$$

$$^\circ\text{F} = (9/5)(^\circ\text{C}) + 32$$

$$1 \text{ kg} = 2.21 \text{ lbm}$$

$$1 \text{ ft}^3_{\text{water}} = 7.48 \text{ gal}$$

$$1 \text{ gal}_{\text{water}} = 8.35 \text{ lbm}$$

$$1 \text{ Curie} = 3.7 \times 10^{10} \text{ dps}$$

**USNRC GENERIC FUNDAMENTALS EXAMINATION
DECEMBER 2011 PWR--FORM A**

QUESTION: 1

Water storage tanks A and B are identical except that tank A receives overpressure protection from a relief valve, whereas tank B uses a safety valve. The relief valve and safety valve have the same pressure setpoints and design flow rates.

Water is continuously added to each tank at the same rate (50 percent of the design flow rate of the relief and safety valves). After the tanks are completely full, tank A pressure will _____; and tank B pressure will _____.

- A. stabilize slightly above the pressure setpoint; fluctuate within a few percent of the pressure setpoint
- B. stabilize slightly above the pressure setpoint; stabilize slightly above the pressure setpoint
- C. fluctuate within a few percent of the pressure setpoint; fluctuate within a few percent of the pressure setpoint
- D. fluctuate within a few percent of the pressure setpoint; stabilize slightly above the pressure setpoint

QUESTION: 2

In a comparison between ball valves and butterfly valves in the same cooling water system application, the valve that would typically experience the greater seat leakage when fully closed and with a large differential pressure is the _____ valve; and the valve that would typically cause the smaller head loss when fully open is the _____ valve.

- A. ball; butterfly
- B. ball; ball
- C. butterfly; butterfly
- D. butterfly; ball

**USNRC GENERIC FUNDAMENTALS EXAMINATION
DECEMBER 2011 PWR--FORM A**

QUESTION: 3

A nuclear power plant is initially operating with the following main steam parameter values:

Main steam pressure: 1,000 psia

Main steam flow rate: 500,000 lbm/hr

Main steam pressure decreases and stabilizes at 950 psia.

Assume 100 percent quality saturated steam and that main steam volumetric flow rate is the same before and after the pressure change.

Which one of the following is the approximate mass flow rate of main steam after the pressure change?

- A. 528,000 lbm/hr
- B. 500,000 lbm/hr
- C. 472,000 lbm/hr
- D. 444,000 lbm/hr

QUESTION: 4

Because of a thermocouple temperature display failure, the millivolt output of a thermocouple circuit is being converted to temperature using conversion tables. The tables are based on a thermocouple reference junction temperature of 32°F. The actual reference junction is located in a panel that is maintained at 120°F. Room temperature surrounding the panel is 80°F.

What adjustment must be made to the temperature value taken from the conversion tables to calculate the actual temperature at the measuring tip of the thermocouple?

- A. Add 48°F.
- B. Subtract 48°F.
- C. Add 88°F.
- D. Subtract 88°F.

**USNRC GENERIC FUNDAMENTALS EXAMINATION
DECEMBER 2011 PWR--FORM A**

QUESTION: 5

A nuclear reactor is shut down at 100 cps in the source range when a loss of coolant accident occurs. Assuming that the source neutron flux level remains constant, how and why will excore source range detector outputs change as homogeneous core voiding increases from 20 percent to 40 percent?

- A. Increases because more neutron leakage is occurring.
- B. Decreases because less neutron leakage is occurring.
- C. Increases because K_{eff} is increasing.
- D. Decreases because K_{eff} is decreasing.

QUESTION: 6

A BF_3 gas-filled detector, operating in the proportional region, is being used to monitor reactor power while shut down. If a complete loss of detector gas pressure occurs, the instrument indication will fail...

- A. upscale.
- B. downscale.
- C. as is.
- D. to midscale.

**USNRC GENERIC FUNDAMENTALS EXAMINATION
DECEMBER 2011 PWR--FORM A**

QUESTION: 7

Refer to the drawing of a lube oil temperature control system (see figure below).

A direct-acting proportional temperature controller is being used to control the heat exchanger lube oil outlet temperature. When the lube oil outlet temperature matches the controller setpoint of 90°F, the controller output signal is 50 percent.

Current lube oil outlet temperature is stable at 100°F with the controller output signal at 70 percent.

What is the temperature proportional band for this controller?

- A. 90°F to 140°F
- B. 90°F to 115°F
- C. 65°F to 140°F
- D. 65°F to 115°F

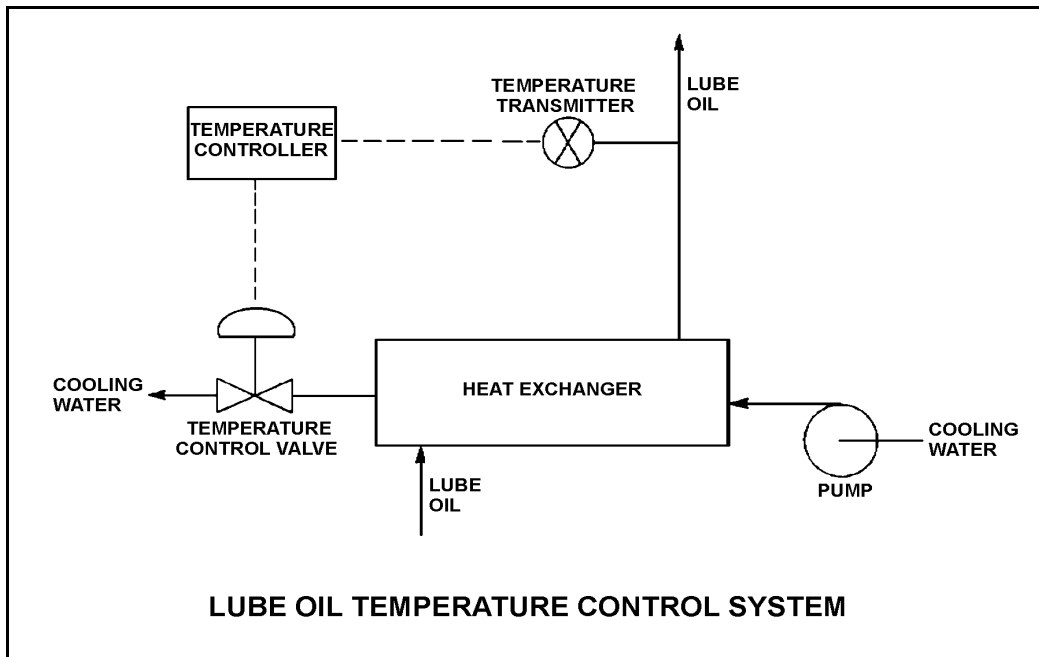

**USNRC GENERIC FUNDAMENTALS EXAMINATION
DECEMBER 2011 PWR--FORM A**

QUESTION: 8

The level in a drain collection tank is being controlled by an automatic level controller and is initially at the controller set point. Flow rate into the tank increases, slowly at first, and then faster until a stable higher flow rate is attained.

As tank level increases, the controller slowly opens a tank drain valve. The level controller output signal increases both as the tank level increases and as the rate of tank level change quickens. After a few minutes, a new, steady-state tank level above the original level is established, with the drain flow rate equal to the supply flow rate.

The controller in this system uses _____ control.

- A. proportional only
- B. proportional plus derivative
- C. proportional plus integral
- D. proportional plus integral plus derivative

**USNRC GENERIC FUNDAMENTALS EXAMINATION
DECEMBER 2011 PWR--FORM A**

QUESTION: 9

Given:

- A directing-acting proportional pneumatic controller will be used to maintain level in a condensate collection tank by positioning an air-operated flow control valve in the tank drain line.
- The controller's input varies directly with tank condensate level.

Which of the flow control valves shown below will be compatible with the controller in the above application?

- A. A and B
- B. B and C
- C. C and D
- D. D and A

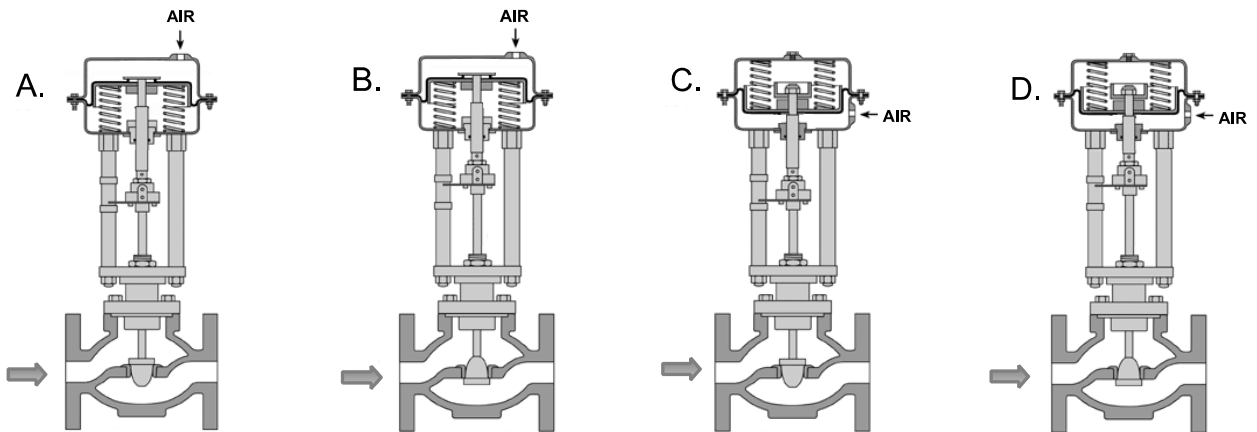

**USNRC GENERIC FUNDAMENTALS EXAMINATION
DECEMBER 2011 PWR--FORM A**

QUESTION: 10

A centrifugal fire water pump takes a suction on an open storage tank and discharges through a fire hose. Which one of the following will cause the pump to operate at shutoff head?

- A. A firefighter inadvertently severs the fire hose.
- B. The fire hose becomes partially crimped in a fire door.
- C. Fire water storage tank level drops below the pump suction tap.
- D. A firefighter adjusts the fire hose nozzle spray pattern from “deluge” to “off”.

**USNRC GENERIC FUNDAMENTALS EXAMINATION
DECEMBER 2011 PWR--FORM A**

QUESTION: 11

Refer to the drawing of a lube oil temperature control system and the associated pump/system operating curves (see figure below).

If the pump is initially operating at point B, how will the operating point change if the temperature controller setpoint is decreased by 10°F?

- A. Operating point B will be located on curve 1 closer to point E.
- B. Operating point B will be located on curve 1 closer to point D.
- C. Operating point B will be located on curve 2 closer to point A.
- D. Operating point B will be located on curve 2 closer to point C.

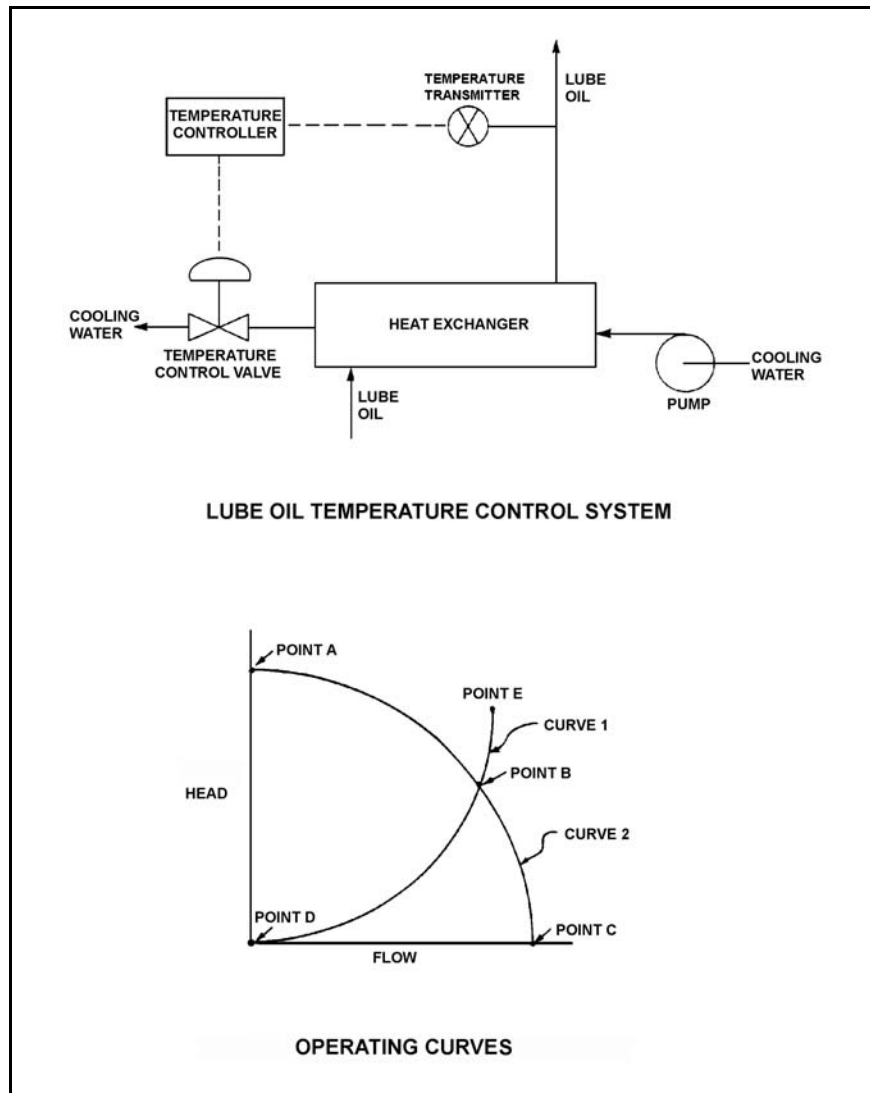

**USNRC GENERIC FUNDAMENTALS EXAMINATION
DECEMBER 2011 PWR--FORM A**

QUESTION: 12

Refer to the drawing of an operating cooling water system (see figure below).

The pump is unable to achieve its rated volumetric flow rate due to cavitation. Which one of the following will enable the pump to achieve a higher volumetric flow rate before cavitation occurs?

- A. Decrease the service water flow rate.
- B. Operate the system at a lower pressure.
- C. Move the surge tank connection closer to the suction of the pump.
- D. Remove the existing pump motor and install a motor with a higher horsepower rating.

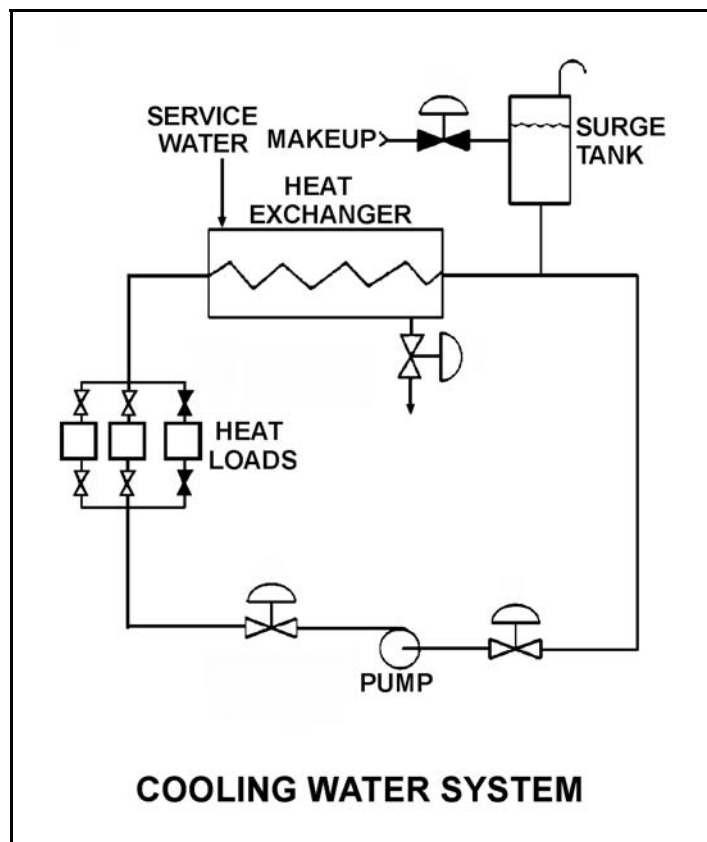

**USNRC GENERIC FUNDAMENTALS EXAMINATION
DECEMBER 2011 PWR--FORM A**

QUESTION: 13

Which one of the following will result in the greatest increase in volumetric flow rate to a system that is currently receiving flow from a positive displacement pump operating at 400 rpm with a discharge pressure of 100 psig?

- A. Increase pump speed to 700 rpm.
- B. Reduce system pressure to decrease pump discharge pressure to 40 psig.
- C. Start a second identical positive displacement pump in series with the first.
- D. Start a second identical positive displacement pump in parallel with the first.

QUESTION: 14

During a surveillance test, a 4,000 KW diesel generator and a 1,000 MW turbine generator at a nuclear power plant are connected to the same power grid.

The following stable generator conditions exist:

<u>Diesel Generator</u>	<u>Turbine Generator</u>
700 KW	800 MW
200 KVAR (out)	100 MVAR (out)

A malfunction then occurs, causing the voltage regulator for the turbine generator to slowly and continuously increase the generator field excitation current. If no operator action is taken, the diesel generator output current will _____ until a generator output breaker trips.

- A. remain about the same
- B. increase continuously
- C. initially increase, and then decrease
- D. initially decrease, and then increase

**USNRC GENERIC FUNDAMENTALS EXAMINATION
DECEMBER 2011 PWR--FORM A**

QUESTION: 15

The starting current in a typical AC induction motor is typically much higher than the full-load running current because...

- A. starting torque is lower than full-load running torque.
- B. starting torque is higher than full-load running torque.
- C. rotor speed during start is too low to generate significant counter electromotive force in the stator.
- D. rotor current during start is too low to generate significant counter electromotive force in the stator.

QUESTION: 16

Given the following parameter values for a feedwater heater:

- Feedwater inlet temperature: 320°F
- Feedwater inlet pressure: 1,000 psia
- Feedwater mass flow rate: 1.0×10^6 lbm/hr
- Extraction steam pressure: 500 psia

Assume that the extraction steam enters the heater as a dry saturated vapor and leaves the heater as a saturated liquid at 500 psia.

Which one of the following is the mass flow rate of extraction steam required to increase feedwater temperature to 380°F?

- A. 5.2×10^4 lbm/hr
- B. 7.9×10^4 lbm/hr
- C. 8.4×10^4 lbm/hr
- D. 8.9×10^4 lbm/hr

**USNRC GENERIC FUNDAMENTALS EXAMINATION
DECEMBER 2011 PWR--FORM A**

QUESTION: 17

Refer to the drawing of an operating lube oil heat exchanger (see figure below).

If deposits accumulate on the outside of the cooling water tubes, cooling water outlet temperature will _____ and lube oil outlet temperature will _____. (Assume that lube oil and cooling water inlet temperatures and flow rates remain the same.)

- A. decrease; increase
- B. decrease; decrease
- C. increase; increase
- D. increase; decrease

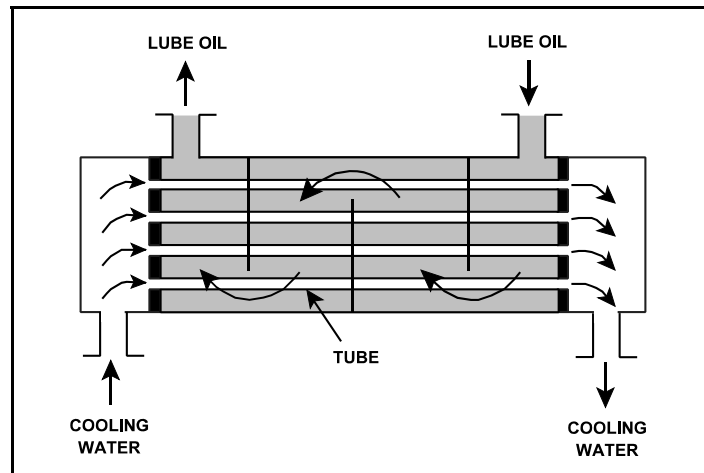

**USNRC GENERIC FUNDAMENTALS EXAMINATION
DECEMBER 2011 PWR--FORM A**

QUESTION: 18

Reactor coolant system (RCS) purification mixed-bed ion exchanger A was removed from service and isolated after several weeks of operation when the RCS boron concentration was 900 ppm. Currently, with ion exchanger B in service, the RCS boron concentration is 450 ppm. If ion exchanger B is isolated and ion exchanger A is immediately returned to service, RCS boron concentration will...

- A. remain the same because the resin in ion exchanger A has already become saturated with boron ions during previous operation.
- B. remain the same because the resin in ion exchanger A has no affinity for the boron ions in the reactor coolant.
- C. increase until the volume of water in ion exchanger A mixes completely with the RCS.
- D. increase until the resin in ion exchanger A reaches equilibrium with the existing RCS boron concentration.

QUESTION: 19

Prior to a scheduled nuclear power plant shutdown, the reactor coolant system was chemically shocked to induce a crud burst. What effect will the crud burst have on the letdown purification ion exchangers?

- A. Decreased radiation levels around the ion exchangers.
- B. Increased flow rate through the ion exchangers.
- C. Decreased ion exchanger outlet conductivity.
- D. Increased pressure drop across the ion exchangers.

**USNRC GENERIC FUNDAMENTALS EXAMINATION
DECEMBER 2011 PWR--FORM A**

QUESTION: 20

Which one of the following describes the normal operation of a local breaker overcurrent trip flag indicator?

- A. Actuates when no lockout is present; satisfies an electrical interlock to remotely close a breaker.
- B. Actuates when a breaker overcurrent trip has occurred; can be manually reset when the overcurrent condition clears.
- C. Actuates when a breaker has failed to trip on an overcurrent condition; can be manually reset when the overcurrent condition clears.
- D. Actuates to cause a breaker trip when the overcurrent trip setpoint is reached; can be remotely reset when the overcurrent condition clears.

QUESTION: 21

A 480 VAC motor is supplied power via an electrical disconnect in series with a circuit breaker. Which one of the following describes the proper operations to isolate power to the motor?

- A. Open the disconnect first, then the breaker.
- B. Open the breaker first, then the disconnect.
- C. Open the device that is closest to the power source first.
- D. Sequence is not important as long as the motor is operating.

**USNRC GENERIC FUNDAMENTALS EXAMINATION
DECEMBER 2011 PWR--FORM A**

QUESTION: 22

If a main generator output breaker is closed when the generator output is 5 degrees out of phase with the local power grid, the main generator will experience a sudden _____ stress; if the breaker remains closed and no additional operator action is taken, the main generator will _____ with the grid.

- A. minor; remain out of phase
- B. minor; become locked into phase
- C. potentially damaging; remain out of phase
- D. potentially damaging; become locked into phase

QUESTION: 23

Delayed neutrons are fission neutrons that...

- A. are released at the instant of fission.
- B. are responsible for the majority of U-235 fissions.
- C. have reached thermal equilibrium with the surrounding medium.
- D. are expelled at a lower average kinetic energy than most other fission neutrons.

**USNRC GENERIC FUNDAMENTALS EXAMINATION
DECEMBER 2011 PWR--FORM A**

QUESTION: 24

A nuclear power plant is operating with the following initial conditions:

- Reactor power is 50 percent
- Rod control is in manual
- Reactor coolant system (RCS) boron concentration is 600 ppm

Disregarding the effects of fission product poisons, which one of the following events will result in a decrease in the available shutdown margin once the plant stabilizes?

- A. Reactor power is reduced to 45 percent with final RCS boron concentration at 620 ppm.
- B. Reactor power is increased to 55 percent with final RCS boron concentration at 580 ppm.
- C. Control rods are withdrawn 3 inches with no change in steady-state reactor power or RCS boron concentration.
- D. Control rods are inserted 3 inches with no change in steady-state reactor power or RCS boron concentration.

**USNRC GENERIC FUNDAMENTALS EXAMINATION
DECEMBER 2011 PWR--FORM A**

QUESTION: 25

Given the following data for the fuel in an operating nuclear reactor core:

<u>Nuclide</u>	<u>Delayed Neutron Fraction</u>	<u>Cross section for thermal fission</u>	<u>Fraction of Total Fission Rate</u>
U-235	0.0065	531 barns	0.58
U-238	0.0148	< 1 barn	0.06
Pu-239	0.0021	743 barns	0.32
Pu-241	0.0049	1009 barns	0.04

What is the core delayed neutron fraction for this reactor?

- A. 0.0044
- B. 0.0055
- C. 0.0063
- D. 0.0071

QUESTION: 26

A nuclear reactor is exactly critical at the point of adding heat during a xenon-free reactor startup near the beginning of core life. Reactor power is ramped to 50 percent over the next 4 hours.

During the power increase, most of the positive reactivity added by the operator is necessary to overcome the negative reactivity associated with the...

- A. buildup of core Xe-135.
- B. increased fuel temperature.
- C. burnout of burnable poisons.
- D. increased reactor coolant temperature.

**USNRC GENERIC FUNDAMENTALS EXAMINATION
DECEMBER 2011 PWR--FORM A**

QUESTION: 27

The amount of pure water required to decrease the reactor coolant boron concentration by 20 ppm near the end of core life (100 ppm) is approximately _____ the amount of pure water required to decrease reactor coolant boron concentration by 20 ppm near the beginning of core life (1,000 ppm).

- A. one-tenth
- B. the same as
- C. 10 times
- D. 100 times

QUESTION: 28

A control rod is positioned in a nuclear reactor with the following neutron flux parameters:

Core average thermal neutron flux = 1×10^{12} neutrons/cm²-sec
Control rod tip neutron flux = 5×10^{12} neutrons/cm²-sec

If the control rod is slightly withdrawn such that the tip of the control rod is located in a neutron flux of 1×10^{13} neutrons/cm²-sec, then the differential control rod worth will increase by a factor of _____. (Assume the average flux is constant.)

- A. 0.5
- B. 1.4
- C. 2.0
- D. 4.0

**USNRC GENERIC FUNDAMENTALS EXAMINATION
DECEMBER 2011 PWR--FORM A**

QUESTION: 29

A nuclear reactor is operating at 85 percent power with all control rods fully withdrawn. Assuming reactor power does not change, which one of the following compares the effects of partially inserting (50 percent) a single center control rod to the effects of dropping (full insertion) the same control rod?

- A. A partially inserted rod causes a smaller change in axial power distribution.
- B. A partially inserted rod causes a smaller change in radial power distribution.
- C. A partially inserted rod causes a greater change in shutdown margin.
- D. A partially inserted rod causes a smaller change in shutdown margin.

QUESTION: 30

A nuclear reactor that has been operating at rated power for 2 weeks is quickly reduced in power to 50 percent. Xenon-135 will reach a new equilibrium condition in _____ hours.

- A. 8 to 10
- B. 20 to 25
- C. 40 to 50
- D. 70 to 80

**USNRC GENERIC FUNDAMENTALS EXAMINATION
DECEMBER 2011 PWR--FORM A**

QUESTION: 31

A nuclear reactor has been operating at 100 percent power for 2 months when a reactor trip occurs. Four hours later, the reactor is critical and stable at 10 percent power.

Which one of the following operator actions is required to maintain reactor coolant temperature stable over the next 18 hours?

- A. Add positive reactivity, then negative reactivity.
- B. Add negative reactivity, then positive reactivity.
- C. Add positive reactivity during the entire period.
- D. Add negative reactivity during the entire period.

QUESTION: 32

Why are burnable poisons installed in a new nuclear reactor core instead of using a larger reactor coolant boron concentration?

- A. To prevent boron precipitation during normal operation.
- B. To establish a more negative moderator temperature coefficient.
- C. To minimize the distortion of the neutron flux distribution caused by soluble boron.
- D. To allow the loading of excessive reactivity in the form of higher fuel enrichment.

**USNRC GENERIC FUNDAMENTALS EXAMINATION
DECEMBER 2011 PWR--FORM A**

QUESTION: 33

During an initial fuel load, the subcritical multiplication factor increases from 1.0 to 4.0 as the first 100 fuel assemblies are loaded. What is the core K_{eff} after the first 100 fuel assemblies are loaded?

- A. 0.25
- B. 0.5
- C. 0.75
- D. 1.0

QUESTION: 34

After taking critical data during a reactor startup, the operator establishes a positive 48-second reactor period to increase reactor power to the point of adding heat (POAH). Which one of the following is the approximate amount of reactivity needed to stabilize power at the POAH? (Assume $\bar{\beta}_{\text{eff}} = 0.00579$.)

- A. -0.10 % $\Delta K/K$
- B. -0.12 % $\Delta K/K$
- C. +0.10 % $\Delta K/K$
- D. +0.12 % $\Delta K/K$

**USNRC GENERIC FUNDAMENTALS EXAMINATION
DECEMBER 2011 PWR--FORM A**

QUESTION: 35

A nuclear power plant is operating at steady state 100 percent power when a reactor trip occurs. As a result of the trip, the core neutron flux will initially decrease on a period that is much _____ than -80 seconds; the period will become approximately -80 seconds about _____ minutes after the trip.

- A. longer; 3
- B. longer; 30
- C. shorter; 3
- D. shorter; 30

QUESTION: 36

A nuclear power plant has been operating at 100 percent power for six months when a reactor trip occurs. Which one of the following describes the source(s) of core heat generation 30 minutes after the reactor trip?

- A. Fission product decay is the only significant source of core heat generation.
- B. Delayed neutron-induced fission is the only significant source of core heat generation.
- C. Fission product decay and delayed neutron-induced fission are both significant sources and produce approximately equal rates of core heat generation.
- D. Fission product decay and delayed neutron-induced fission are both insignificant sources and generate core heat at rates that are less than the rate of ambient heat loss from the core.

**USNRC GENERIC FUNDAMENTALS EXAMINATION
DECEMBER 2011 PWR--FORM A**

QUESTION: 37

An enclosed water storage tank is pressurized with nitrogen to prevent air inleakage. A differential pressure detector with a dry reference leg is used to measure the tank level.

To achieve the greatest accuracy of measurement, the low pressure side of the detector should sense which one of the following?

- A. The pressure at the bottom of the tank.
- B. The pressure of the atmosphere surrounding the tank.
- C. The pressure of a column of water external to the tank.
- D. The pressure of the gas space at the top of the tank.

QUESTION: 38

Given the following:

- A saturated steam-water mixture with an inlet quality of 40 percent is flowing through a moisture separator.
- The moisture separator is 100 percent efficient for removing water.

How much water will be removed by the moisture separator from 50 lbm of the steam-water mixture?

- A. 10 lbm
- B. 20 lbm
- C. 30 lbm
- D. 40 lbm

**USNRC GENERIC FUNDAMENTALS EXAMINATION
DECEMBER 2011 PWR--FORM A**

QUESTION: 39

Given the following initial conditions for a spent fuel pool:

- Spent fuel decay heat rate: 5.0 Mw
- Spent fuel pool water temperature: 90°F
- Spent fuel pool water mass: 2.5×10^6 lbm
- Spent fuel pool water specific heat: 1.0 Btu/lbm-°F
- Spent fuel pool surface pressure: 14.7 psia

If a complete loss of spent fuel pool cooling occurs, how long will it take for spent fuel pool water temperature to reach 212°F? (Assume that the spent fuel pool remains in thermal equilibrium, and that there is no heat removal from the spent fuel pool.)

- A. 18 hours
- B. 31 hours
- C. 48 hours
- D. 61 hours

QUESTION: 40

Which one of the following is an advantage of condensate depression in the main condenser?

- A. Increased secondary cycle efficiency.
- B. Increased feedwater temperature entering the steam generators.
- C. Increased net positive suction head available to condensate pumps.
- D. Increased inventory in the main condenser hotwell.

**USNRC GENERIC FUNDAMENTALS EXAMINATION
DECEMBER 2011 PWR--FORM A**

QUESTION: 41

If superheating of the inlet steam to a low pressure turbine is reduced, low pressure turbine work output will _____; and low pressure turbine exhaust steam moisture content will _____.
(Assume steam mass flow rate does not change.)

- A. decrease; increase
- B. decrease; decrease
- C. remain the same; increase
- D. remain the same; decrease

QUESTION: 42

Which one of the following methods will increase the possibility and/or severity of water hammer?

- A. Opening and closing system valves slowly.
- B. Venting fluid systems prior to starting a pump.
- C. Starting a centrifugal pump with the discharge valve fully open.
- D. Starting a centrifugal pump with the discharge valve fully closed.

**USNRC GENERIC FUNDAMENTALS EXAMINATION
DECEMBER 2011 PWR--FORM A**

QUESTION: 43

A vented water storage tank contains 60 feet of water at 70°F. A cracked weld at the bottom of the tank results in a leak rate of 12 gpm. If makeup water flow rate is 5 gpm, at what water level will the tank stabilize?

- A. 38.7 feet
- B. 25.0 feet
- C. 10.4 feet
- D. 0.0 feet

QUESTION: 44

A nuclear power plant was operating at a steady-state power level with the following main condenser parameters:

Main condenser pressure: 1.2 psia
Cooling water inlet temperature: 60°F
Cooling water outlet temperature: 84°F

As a result of increased condenser air inleakage, the overall heat transfer coefficient of the main condenser decreases by 25 percent. Main condenser heat transfer rate and cooling water temperatures are unchanged. Which one of the following is the approximate resulting pressure in the main condenser?

- A. 1.7 psia
- B. 2.3 psia
- C. 3.0 psia
- D. 4.6 psia

**USNRC GENERIC FUNDAMENTALS EXAMINATION
DECEMBER 2011 PWR--FORM A**

QUESTION: 45

Refer to the drawing of a pool boiling curve (see figure below).

Identify the region of the curve where the most efficient form of heat transfer exists.

- A. Region I
- B. Region II
- C. Region III
- D. Region IV

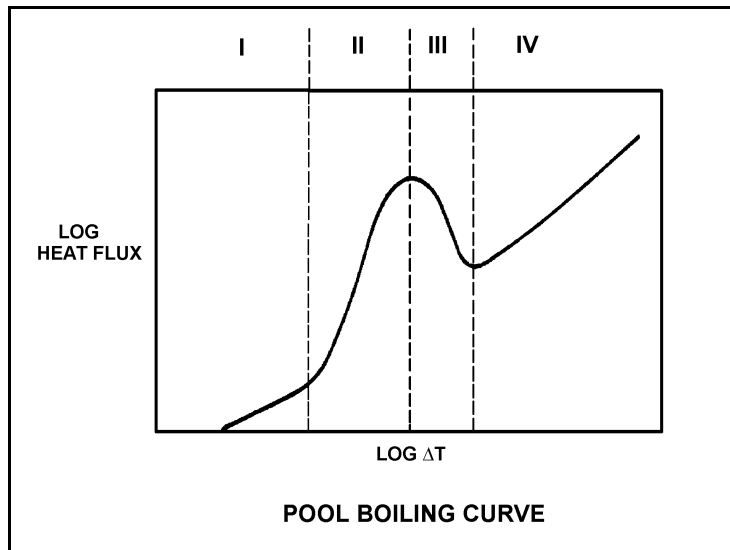

**USNRC GENERIC FUNDAMENTALS EXAMINATION
DECEMBER 2011 PWR--FORM A**

QUESTION: 46

Which one of the following is an example of significant radiative heat transfer?

- A. Heat transfer from the fuel pellet to the fuel cladding via direct contact.
- B. Heat transfer from the reactor coolant to the feedwater in a steam generator.
- C. Heat transfer from the center to the edge of a fuel pellet at end of core life.
- D. Heat transfer from the fuel cladding to the reactor coolant through a stable vapor layer.

QUESTION: 47

Subcooled reactor coolant flows into the bottom of a fuel assembly coolant channel and exits the top of the channel as a saturated steam-water mixture with a 98 percent moisture content. How does the overall heat transfer coefficient in the coolant channel change as the coolant travels upward along the channel?

- A. Increases only.
- B. Increases, then decreases.
- C. Decreases only.
- D. Decreases, then increases.

**USNRC GENERIC FUNDAMENTALS EXAMINATION
DECEMBER 2011 PWR--FORM A**

QUESTION: 48

Refer to the drawing of a section of pipe that contains flowing subcooled water (see figure below).

Given:

Pressure at P_1 is 34 psig.

Pressure at P_2 is 20 psig.

Pressure change due to change in velocity is 2 psig.

Pressure change due to change in elevation is 8 psig.

The pressure decrease due to friction head loss between P_1 and P_2 is _____; and the direction of flow is from _____.

- A. 2 psig; left to right
- B. 2 psig; right to left
- C. 4 psig; left to right
- D. 4 psig; right to left

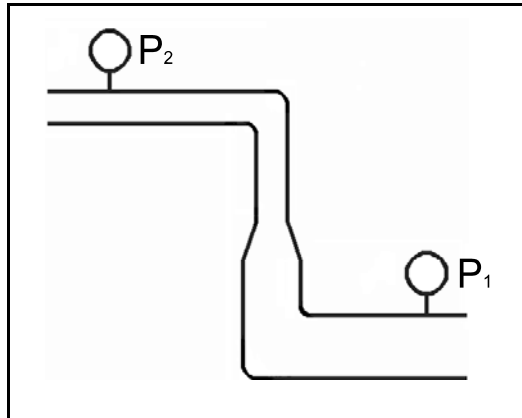

**USNRC GENERIC FUNDAMENTALS EXAMINATION
DECEMBER 2011 PWR--FORM A**

QUESTION: 49

A nuclear reactor is operating at 75 percent power at the middle of a fuel cycle with radial power distribution peaked in the center of the core. All control rods are fully withdrawn and in manual control.

Assuming all control rods remain fully withdrawn, except as noted, which one of the following will cause the maximum steady-state radial peaking (or hot channel) factor to decrease?

- A. Turbine load/reactor power is reduced by 20 percent.
- B. A control rod located at the edge of the core drops into the core.
- C. Reactor coolant system boron concentration is reduced by 10 ppm.
- D. The reactor is operated continuously at 75 percent power for three months.

QUESTION: 50

During an uncontrolled cooldown of a reactor coolant system, the component most susceptible to pressurized thermal shock is the...

- A. reactor vessel.
- B. steam generator tube sheet.
- C. cold leg accumulator penetration.
- D. loop resistance temperature detector penetration.

***** FINAL ANSWER KEY *****

**DECEMBER 2011 NRC GENERIC FUNDAMENTALS EXAMINATION
PRESSURIZED WATER REACTOR - ANSWER KEY**

<u>FORM A</u>	<u>FORM B</u>	<u>ANS.</u>	<u>FORM A</u>	<u>FORM B</u>	<u>ANS.</u>
1	15	A	26	40	B
2	16	D	27	41	C
3	17	C	28	42	D
4	18	C	29	43	B
5	19	A	30	44	C
6	20	B	31	45	A
7	21	D	32	46	B
8	22	B	33	47	C
9	23	B	34	48	A
10	24	D	35	49	C
11	25	D	36	50	A
12	26	C	37	1	D
13	27	D	38	2	C
14	28	D	39	3	A
15	29	C	40	4	C
16	30	C	41	5	A
17	31	A	42	6	C
18	32	D	43	7	C
19	33	D	44	8	A
20	34	B	45	9	B
21	35	B	46	10	D
22	36	B	47	11	A
23	37	D	48	12	D
24	38	B	49	13	D
25	39	B	50	14	A