

**UNITED STATES NUCLEAR REGULATORY COMMISSION  
BOILING WATER REACTOR GENERIC FUNDAMENTALS EXAMINATION  
DECEMBER 2012--FORM A**

**Please Print**

Name: \_\_\_\_\_

Docket No.: \_\_\_\_\_

Facility: \_\_\_\_\_

Start Time: \_\_\_\_\_ Stop Time: \_\_\_\_\_

**INSTRUCTIONS TO APPLICANT**

Answer all the test items using the answer sheet provided, ensuring a single answer is marked for each test item. Each test item has equal point value. A score of at least 80 percent is required to pass this portion of the NRC operator licensing written examination. All examination materials will be collected 3 hours after the examination begins. This examination applies to a typical U.S. boiling water reactor (BWR) nuclear power plant.

SECTION	QUESTIONS	% OF TOTAL	SCORE
COMPONENTS	1 - 22		
REACTOR THEORY	23 - 36		
THERMODYNAMICS	37 - 50		
TOTALS	50		

All work performed on this examination is my own. I have neither given nor received aid.

\_\_\_\_\_  
Applicant's Signature

## RULES AND INSTRUCTIONS FOR THE NRC GENERIC FUNDAMENTALS EXAMINATION

During the administration of this examination the following rules apply:

NOTE: The term "control rod" refers to the length of neutron absorber material that can be positioned by the operator to change core reactivity.

NOTE: Numerical answers are rounded to the nearest whole number unless otherwise indicated.

1. Print your name in the blank provided on the cover sheet of the examination.
2. Fill in your individual docket number.
3. Fill in the name of your facility.
4. Fill in your start and stop times at the appropriate times.
5. Two aids are provided for your use during the examination:
  - (1) An Equations and Conversions Sheet contained within the examination copy, and
  - (2) Steam tables and Mollier Diagram provided by your proctor.
6. Place your answers on the answer sheet provided. Credit will only be given for answers properly marked on this sheet. Follow the instructions for filling out the answer sheet.
7. Scrap paper will be provided for calculations.
8. Cheating on the examination will result in the automatic forfeiture of this examination. Cheating could also result in severe penalties.
9. Restroom trips are limited. Only **one** examinee may leave the room at a time. In order to avoid the appearance or possibility of cheating, avoid all contact with anyone outside the examination room.
10. After you have completed the examination, sign the statement on the cover sheet indicating that the work is your own and you have neither given nor received any assistance in completing the examination. Either pencil or pen may be used.
11. Turn in your examination materials, answer sheet on top, followed by the examination copy and the examination aids, e.g., steam tables, handouts, and scrap paper.
12. After turning in your examination materials, leave the examination area as defined by the proctor. If after leaving you are found in the examination area while the examination is in progress, your examination may be forfeited.

**GENERIC FUNDAMENTALS EXAMINATION**  
**EQUATIONS AND CONVERSIONS SHEET**

**EQUATIONS**

---

$$\dot{Q} = \dot{m}c_p\Delta T$$

$$A = A_0e^{-\lambda t}$$

$$\dot{Q} = \dot{m}\Delta h$$

$$CR_{S/D} = S/(1 - K_{eff})$$

$$\dot{Q} = UA\Delta T$$

$$CR_1(1 - K_{eff_1}) = CR_2(1 - K_{eff_2})$$

$$\dot{Q} \propto \dot{m}_{Nat\ Circ}^3$$

$$1/M = CR_1/CR_x$$

$$\Delta T \propto \dot{m}_{Nat\ Circ}^2$$

$$A = \pi r^2$$

$$K_{eff} = 1/(1 - \rho)$$

$$F = PA$$

$$\rho = (K_{eff} - 1)/K_{eff}$$

$$\dot{m} = \rho A \bar{v}$$

$$SUR = 26.06/\tau$$

$$\dot{W}_{Pump} = \dot{m}\Delta P v$$

$$\tau = \frac{\bar{\beta}_{eff} - \rho}{\lambda_{eff} \rho}$$

$$P = IE$$

$$\rho = \frac{\ell^*}{\tau} + \frac{\bar{\beta}_{eff}}{1 + \lambda_{eff} \tau}$$

$$P_A = \sqrt{3}IE$$

$$P_T = \sqrt{3}IEpf$$

$$\ell^* = 1.0 \times 10^{-4} \text{ sec}$$

$$P_R = \sqrt{3}IE\sin\theta$$

$$\lambda_{eff} = 0.1 \text{ sec}^{-1} \text{ (for small positive } \rho)$$

$$\text{Thermal Efficiency} = \text{Net Work Out/Energy In}$$

$$DRW \propto \phi_{tip}^2 / \phi_{avg}^2$$

$$\frac{g(z_2 - z_1)}{g_c} + \frac{(\bar{v}_2^2 - \bar{v}_1^2)}{2g_c} + v(P_2 - P_1) + (u_2 - u_1) + (q - w) = 0$$

$$P = P_0e^{t/\tau}$$

$$g_c = 32.2 \text{ lbf-ft/lbf-sec}^2$$

$$P = P_010^{SUR(t)}$$

**CONVERSIONS**

---

$$1 \text{ MW} = 3.41 \times 10^6 \text{ Btu/hr}$$

$$^{\circ}\text{C} = (5/9)(^{\circ}\text{F} - 32)$$

$$1 \text{ ft}^3_{\text{water}} = 7.48 \text{ gal}$$

$$1 \text{ hp} = 2.54 \times 10^3 \text{ Btu/hr}$$

$$^{\circ}\text{F} = (9/5)(^{\circ}\text{C}) + 32$$

$$1 \text{ gal}_{\text{water}} = 8.35 \text{ lbm}$$

$$1 \text{ Btu} = 778 \text{ ft-lbf}$$

$$1 \text{ kg} = 2.21 \text{ lbm}$$

$$1 \text{ Curie} = 3.7 \times 10^{10} \text{ dps}$$

**USNRC GENERIC FUNDAMENTALS EXAMINATION  
DECEMBER 2012 BWR--FORM A**

QUESTION: 1

A vertical safety valve has a compressed spring assembly that is applying 2,500 lbf to the top of the valve disk in opposition to system pressure. System pressure is being exerted on the underside of the valve disk that is 5 inches in diameter.

Which one of the following is the approximate system pressure at which the safety valve will open?

- A. 32 psig
- B. 127 psig
- C. 159 psig
- D. 500 psig

**USNRC GENERIC FUNDAMENTALS EXAMINATION  
DECEMBER 2012 BWR--FORM A**

QUESTION: 2

Refer to the drawing of a water supply pump with two suction sources (see figure below). All motor-operated valves (MOV) are currently closed.

Which one of the following MOV interlocks will permit the pump to take a suction on either the building sump or the water storage tank, while preventing the two sources from being cross-connected?

- A. Neither MOV-1 nor MOV-2 can be opened unless MOV-3 is fully closed.
- B. None of the MOVs can be opened unless at least one MOV remains fully closed.
- C. None of the MOVs can be opened unless at least two MOVs remain fully closed.
- D. Neither MOV-1 nor MOV-2 can be opened unless the other source MOV is fully closed.

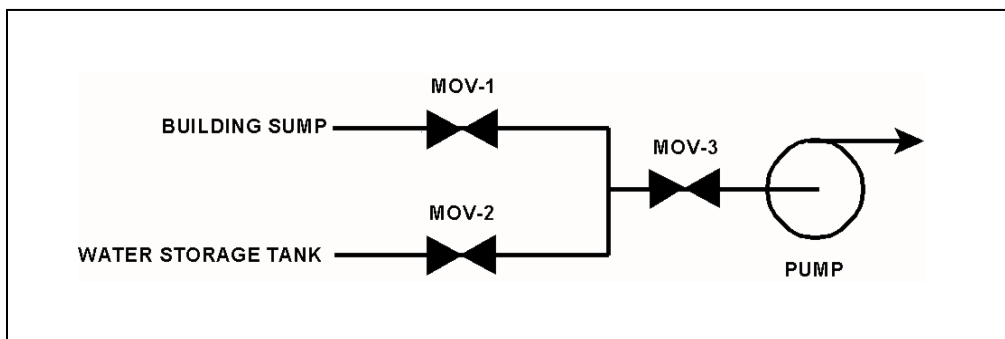

QUESTION: 3

When transferring a valve controller from the manual mode to the automatic mode, the automatic valve controller output signal should be \_\_\_\_\_ the manual valve controller output signal at the time of transfer.

- A. equal to
- B. greater than
- C. less than
- D. increasing with

**USNRC GENERIC FUNDAMENTALS EXAMINATION  
DECEMBER 2012 BWR--FORM A**

QUESTION: 4

Refer to the drawing of a vented water storage tank with a differential pressure (D/P) level detection system (see figure below). The water in the tank and reference leg is at the same temperature.

The tank level indicator was just calibrated to indicate 0 percent when the tank is empty and 100 percent when the water level reaches the upper tap. The indicator's display range is 0 percent to 120 percent. The initial water level is as indicated in the figure.

If the tank water level slowly increases and stabilizes just below the top of the tank, the level indication will increase until...

- A. the water level stabilizes, at which time the level indication will stabilize at 100 percent.
- B. the water level stabilizes, at which time the level indication will stabilize at a value greater than 100 percent.
- C. the water level reaches the upper tap, at which time the level indication will remain at 100 percent as the water level continues to increase.
- D. the water level reaches the upper tap, at which time the level indication will continue to increase as the water level continues to increase.

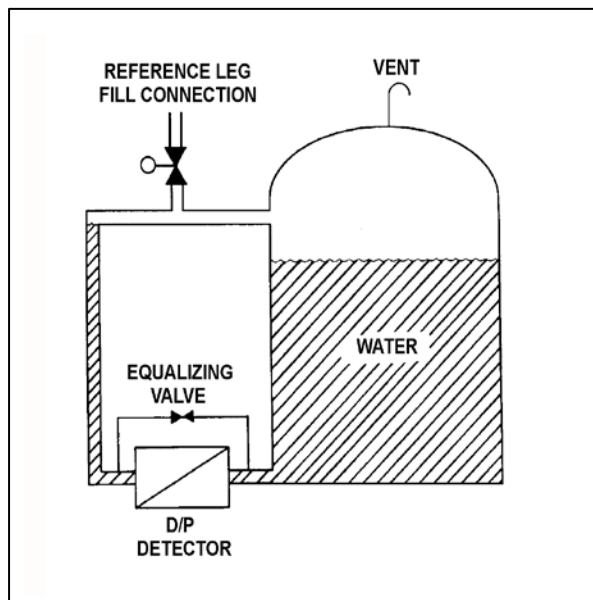

**USNRC GENERIC FUNDAMENTALS EXAMINATION  
DECEMBER 2012 BWR--FORM A**

QUESTION: 5

Refer to the drawing of a simple thermocouple circuit (see figure below).

The measuring junction temperature is currently  $300^{\circ}\text{F}$  while the reference junction temperature is being held constant at  $120^{\circ}\text{F}$ . The thermocouple circuit is capable of indicating  $32^{\circ}\text{F}$  to  $600^{\circ}\text{F}$  and has just been calibrated at the current conditions.

If the measuring junction temperature decreases and stabilizes at  $90^{\circ}\text{F}$ , what temperature will be indicated?

- A.  $32^{\circ}\text{F}$
- B.  $60^{\circ}\text{F}$
- C.  $90^{\circ}\text{F}$
- D.  $120^{\circ}\text{F}$

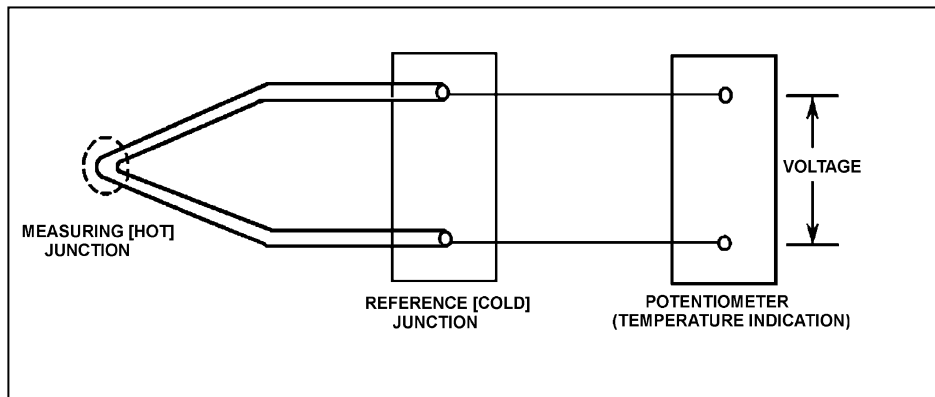

**USNRC GENERIC FUNDAMENTALS EXAMINATION  
DECEMBER 2012 BWR--FORM A**

QUESTION: 6

Which one of the following devices is commonly used to provide remote indication of valve position on an analog meter in units of "percent of full open"?

- A. Limit switch
- B. Reed switch
- C. Linear variable differential transformer
- D. Resistance temperature detector

QUESTION: 7

What is the effect on a gas-filled neutron detector operating in the proportional region if the detector voltage is increased such that the detector operates closer to the high end of the proportional region?

- A. Neutron-induced pulses will become so large that gamma pulse discrimination is no longer needed, yielding a more accurate neutron count rate.
- B. The positive space charge effect will increase and prevent collection of both gamma- and neutron-induced pulses, yielding a less accurate neutron count rate.
- C. A high rate of incident gamma radiation will result in the combination of multiple small gamma-induced pulses into larger pulses. The larger combined pulses will be counted as neutron-induced pulses, yielding a less accurate neutron count rate.
- D. Detection of any single ionizing event will result in ionizing nearly the entire detector gas volume. The resulting large pulses will prevent the detector from differentiating between radiation types, yielding a less accurate neutron count rate.



**USNRC GENERIC FUNDAMENTALS EXAMINATION  
DECEMBER 2012 BWR--FORM A**

QUESTION: 8

Refer to the logic diagram for a valve controller (see figure below).

Which one of the following combinations of inputs will result in the valve receiving an OPEN signal?

INPUTS

	1	2	3	4
A.	Off	On	Off	Off
B.	Off	On	On	Off
C.	On	Off	Off	On
D.	On	Off	On	On

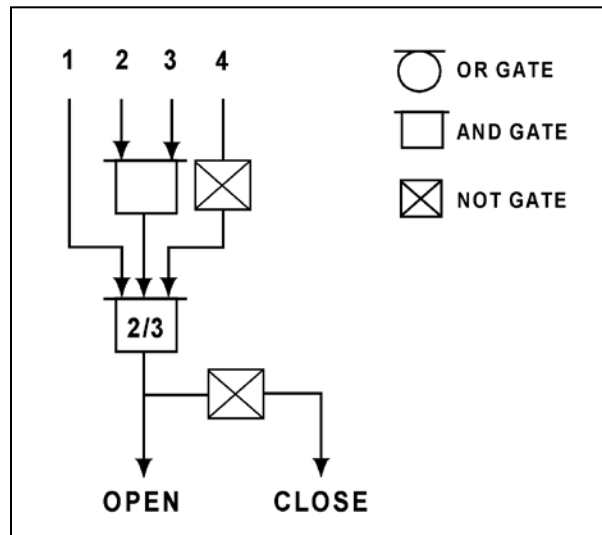

**USNRC GENERIC FUNDAMENTALS EXAMINATION  
DECEMBER 2012 BWR--FORM A**

QUESTION: 9

What is the purpose of a valve positioner in a typical pneumatic valve control system?

- A. Convert the valve controller pneumatic output signal to a mechanical force to position the valve.
- B. Convert the valve controller pneumatic output signal to an electrical output to position the valve.
- C. Compare valve controller pneumatic output signal to setpoint error, and adjust valve actuator air supply pressure to position the valve.
- D. Compare valve controller pneumatic output signal to valve position, and adjust valve actuator air supply pressure to position the valve.

QUESTION: 10

Which one of the following is an effective method for ensuring that a centrifugal pump remains primed and does not become gas bound during operation and after shutdown?

- A. Install the pump below the level of the suction supply.
- B. Install a check valve in the discharge piping of the pump.
- C. Install an orifice plate in the discharge piping of the pump.
- D. Install a pump recirculation line from the pump discharge piping to the pump suction piping.

**USNRC GENERIC FUNDAMENTALS EXAMINATION  
DECEMBER 2012 BWR--FORM A**

QUESTION: 11

Refer to the drawing of an operating cooling water system (see figure below). The pump discharge valve is partially throttled to produce the following initial pump operating parameters:

Pump discharge pressure = 45 psig  
Pump suction pressure = 15 psig  
Pump flow rate = 120 gpm

After a few hours of operation, the current pump operating parameters are as follows:

Pump discharge pressure = 48 psig  
Pump suction pressure = 18 psig  
Pump flow rate: = 120 gpm

Which one of the following could be responsible for the change in pump operating parameters?

- A. The pump speed increased with no other changes to the system.
- B. The surge tank level increased with no other changes to the system.
- C. The pump discharge valve was closed further while pump speed increased.
- D. The pump discharge valve was closed further while surge tank level increased.

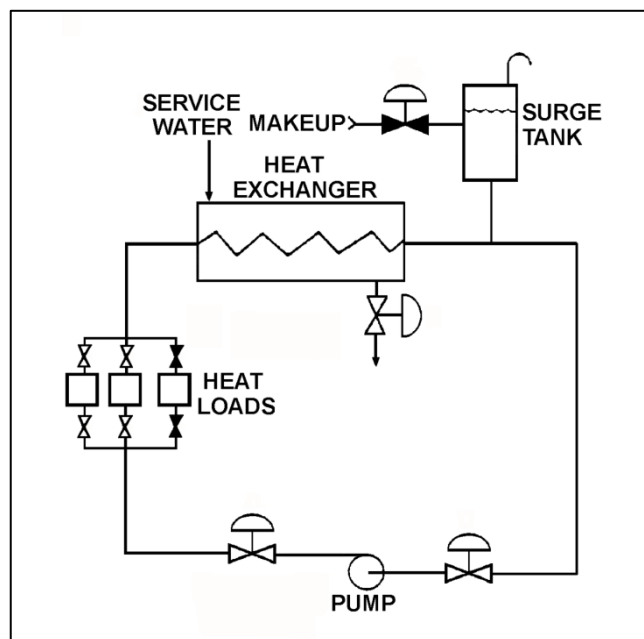

**USNRC GENERIC FUNDAMENTALS EXAMINATION  
DECEMBER 2012 BWR--FORM A**

QUESTION: 12

Refer to the drawing of a centrifugal pump taking suction from the bottom of an open storage tank containing water at 66°F (see figure below). Pump and water level elevations are indicated in the figure. Assume standard atmospheric pressure.

Assuming that pump suction head loss is negligible, what is the approximate value of net positive suction head available to the pump?

- A. 6 feet
- B. 12 feet
- C. 39 feet
- D. 45 feet

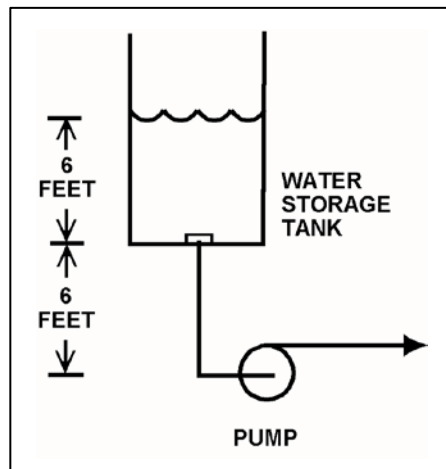

**USNRC GENERIC FUNDAMENTALS EXAMINATION  
DECEMBER 2012 BWR--FORM A**

QUESTION: 13

A centrifugal fire water pump takes suction from an open storage tank and discharges through a fire hose. Which one of the following will cause the pump to operate at shutoff head?

- A. A firefighter inadvertently severs the fire hose.
- B. The fire hose becomes partially crimped in a fire door.
- C. Fire water storage tank level drops below the pump suction tap.
- D. A firefighter adjusts the fire hose nozzle spray pattern from DELUGE to OFF.

QUESTION: 14

Consider two identical single-speed AC induction motors, one of which is connected to a radial-flow centrifugal pump and the other to a rotary-type positive displacement pump (PDP). Both pumps are taking suction from the bottom of a vented water storage tank.

Each pump is operating with the following initial conditions:

Flow rate = 200 gpm  
Backpressure = 600 psig  
Motor current = 100 amps

If the backpressure for each pump decreases to 400 psig, the centrifugal pump will have a \_\_\_\_\_ flow rate than the PDP; and the centrifugal pump will have a \_\_\_\_\_ motor current than the PDP.

- A. lower; lower
- B. lower; higher
- C. higher; lower
- D. higher; higher

**USNRC GENERIC FUNDAMENTALS EXAMINATION  
DECEMBER 2012 BWR--FORM A**

QUESTION: 15

A main generator is connected to an infinite power grid with the following generator output parameters:

22 KV  
60 Hertz  
575 MW  
100 MVAR (in)

Which one of the following contains a combination of minor adjustments to the main generator voltage regulator and speed control setpoints such that each adjustment will cause the main generator to operate at a power factor closer to 1.0. (Assume that generator power factor remains less than 1.0.)

	<u>Voltage Setpoint</u>	<u>Speed Setpoint</u>
A.	Increase	Increase
B.	Increase	Decrease
C.	Decrease	Increase
D.	Decrease	Decrease

QUESTION: 16

The rate of heat transfer between two liquids in a single-phase heat exchanger will decrease if the... (Assume constant specific heat capacities.)

- A. inlet temperatures of both liquids decrease by 20°F.
- B. inlet temperatures of both liquids increase by 20°F.
- C. flow rate of the colder liquid decreases by 10 percent.
- D. flow rate of the hotter liquid increases by 10 percent.

**USNRC GENERIC FUNDAMENTALS EXAMINATION  
DECEMBER 2012 BWR--FORM A**

QUESTION: 17

Refer to the drawing of an operating water cleanup system (see figure below).

Valves A, B, and C are fully open. Valve D is 80 percent open. If valve D is throttled to 50 percent, the temperature at point...

- A. 3 will decrease.
- B. 4 will increase.
- C. 5 will increase.
- D. 6 will decrease.

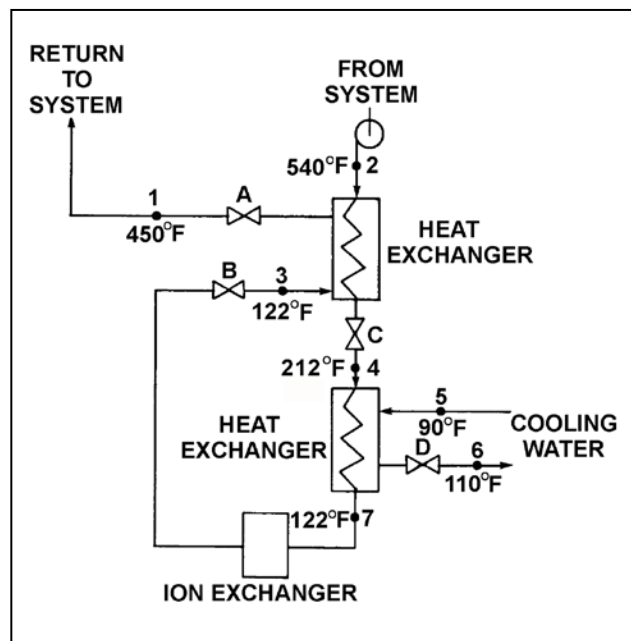

**USNRC GENERIC FUNDAMENTALS EXAMINATION  
DECEMBER 2012 BWR--FORM A**

QUESTION: 18

A reactor is shut down with a reactor coolant temperature of 400°F and all control rods fully inserted. What is the major adverse consequence resulting from rapidly reducing the reactor coolant temperature to 250°F?

- A. Excessive stress in the ceramic fuel pellets.
- B. Excessive stress in the reactor vessel wall.
- C. Uncontrolled reactor criticality.
- D. Loss of core inlet subcooling.

QUESTION: 19

Water is passing through an ion exchanger that contains only anion exchange resin. Currently, every available ion exchange site in the resin has exchanged its original anion and is occupied by a chloride (Cl<sup>-</sup>) anion. Assuming that water temperature does not change, what will be the effect on the ion exchanger if a new anion impurity is introduced into the water entering the ion exchanger?

- A. The new anions will bypass the occupied ion exchange sites under all circumstances.
- B. The new anions will take the place of the Cl<sup>-</sup> anions on the ion exchange sites under all circumstances.
- C. The new anions will take the place of the Cl<sup>-</sup> anions on the ion exchange sites only if the new anions have a greater negative charge than the Cl<sup>-</sup> anions.
- D. The new anions will take the place of the Cl<sup>-</sup> anions on the ion exchange sites only if the new anions have a greater affinity for the anion exchange resin.



**USNRC GENERIC FUNDAMENTALS EXAMINATION  
DECEMBER 2012 BWR--FORM A**

QUESTION: 20

A result of proper demineralizer operation on water with ionic impurities is that the exiting water will always have a...

- A. higher pH.
- B. lower pH.
- C. higher conductivity.
- D. lower conductivity.

**USNRC GENERIC FUNDAMENTALS EXAMINATION  
DECEMBER 2012 BWR--FORM A**

QUESTION: 21

Refer to the drawing of a valve motor control circuit (see figure below) for a valve that is currently fully open and has a 10-second stroke time.

**Note:** Limit switch (LS) contacts are shown open regardless of valve position, but relay contacts are shown open/closed according to the standard convention for control circuit drawings.

The operator takes the control switch to CLOSE. Two seconds later, after verifying the valve is closing, the operator releases the control switch. Which one of the following describes the valve motor control circuit alarm response after the switch is released?

- A. The alarm will continue to actuate for approximately 8 seconds.
- B. The alarm will continue to actuate until additional operator action is taken.
- C. The alarm will actuate after approximately 8 seconds.
- D. The alarm will not actuate until additional operator action is taken.

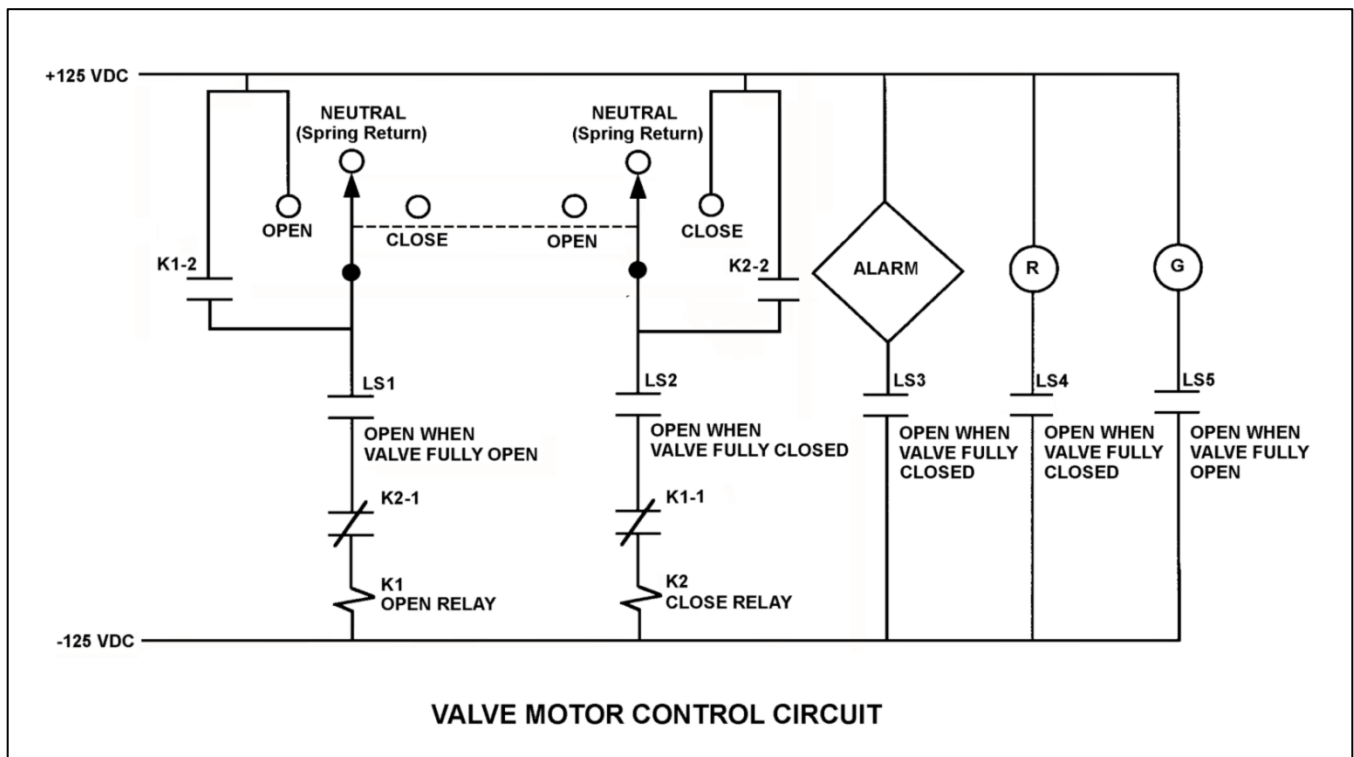

**USNRC GENERIC FUNDAMENTALS EXAMINATION  
DECEMBER 2012 BWR--FORM A**

QUESTION: 22

A main generator is being prepared for paralleling with an infinite power grid. Which one of the following indicates that the main generator and the grid are in phase?

- A. The synchroscope pointer is at the 12 o'clock position.
- B. The frequency of the generator is equal to the frequency of the grid.
- C. The synchroscope pointer is turning slowly in the clockwise direction.
- D. The synchroscope pointer is turning slowly in the counterclockwise direction.

QUESTION: 23

During a brief time interval in a typical reactor operating steady-state at the beginning of a fuel cycle,  $1.0 \times 10^5$  delayed neutrons were emitted.

Approximately how many prompt neutrons were emitted in the reactor during this same time interval?

- A.  $1.5 \times 10^5$
- B.  $6.5 \times 10^6$
- C.  $1.5 \times 10^7$
- D.  $6.5 \times 10^8$

**USNRC GENERIC FUNDAMENTALS EXAMINATION  
DECEMBER 2012 BWR--FORM A**

QUESTION: 24

A 1.5 MeV neutron is about to interact with a U-238 nucleus in an operating reactor. Which one of the following describes the most likely interaction and its effect on  $K_{\text{eff}}$ ?

- A. The neutron will be scattered, thereby leaving  $K_{\text{eff}}$  unchanged.
- B. The neutron will be absorbed and the nucleus will fission, thereby decreasing  $K_{\text{eff}}$ .
- C. The neutron will be absorbed and the nucleus will fission, thereby increasing  $K_{\text{eff}}$ .
- D. The neutron will be absorbed and the nucleus will decay to Pu-239, thereby increasing  $K_{\text{eff}}$ .

QUESTION: 25

Given the following data for a reactor:

- The average delayed neutron fraction is 0.0068.
- The effective delayed neutron fraction is 0.0065.

The above data indicates that this reactor is operating near the \_\_\_\_\_ of a fuel cycle; and a typical delayed neutron is \_\_\_\_\_ likely than a typical prompt neutron to cause another fission in this reactor.

- A. beginning; less
- B. beginning; more
- C. end; less
- D. end; more

**USNRC GENERIC FUNDAMENTALS EXAMINATION  
DECEMBER 2012 BWR--FORM A**

QUESTION: 26

Which one of the following has the smallest microscopic cross section for absorption of a thermal neutron in an operating reactor?

- A. Uranium-235
- B. Uranium-238
- C. Samarium-149
- D. Xenon-135

QUESTION: 27

During a reactor power decrease from steady-state 100 percent to steady-state 20 percent, the smallest addition of positive reactivity will be caused by the change in...

- A. void percentage.
- B. fuel temperature.
- C. xenon concentration.
- D. moderator temperature.

**USNRC GENERIC FUNDAMENTALS EXAMINATION  
DECEMBER 2012 BWR--FORM A**

QUESTION: 28

A reactor is operating steady-state at the point of adding heat (POAH) during a reactor startup near the beginning of a fuel cycle. Reactor pressure is stable at 600 psig and the main steam isolation valves are closed. There is a small but significant heat loss from the reactor vessel to the surroundings.

If a control rod is manually inserted for 5 seconds and the reactor does not scram, when conditions stabilize reactor power will be \_\_\_\_\_; and reactor vessel pressure will be \_\_\_\_\_.

- A. at the POAH; 600 psig
- B. at the POAH; less than 600 psig
- C. less than the POAH; 600 psig
- D. less than the POAH; less than 600 psig

QUESTION: 29

Which one of the following describes the change in magnitude (absolute value) of differential control rod worth during the complete withdrawal of a fully inserted control rod?

- A. Increases, then decreases.
- B. Decreases, then increases.
- C. Increases continuously.
- D. Decreases continuously.

**USNRC GENERIC FUNDAMENTALS EXAMINATION  
DECEMBER 2012 BWR--FORM A**

QUESTION: 30

If a reactor that has operated at 100 percent power for 10 days is shut down rapidly, the xenon-135 concentration will...

- A. slowly decrease to almost zero in 3 days.
- B. increase to a new equilibrium concentration in 3 days.
- C. peak in about a half day, and then decrease to almost zero in 3 days.
- D. decrease directly with reactor power.

QUESTION: 31

A nuclear power plant was initially operating at steady-state 100 percent power at the end of a fuel cycle (EOC) when the plant was shut down for refueling. After refueling, the reactor was restarted and the plant is currently operating at steady-state 100 percent power at the beginning of a fuel cycle (BOC). Assume the average energy released by each fission did not change.

Compared to the equilibrium xenon-135 concentration at 100 percent power just prior to the refueling, the current equilibrium xenon-135 concentration is...

- A. greater, because the higher fission rate at BOC produces xenon-135 at a faster rate.
- B. greater, because the lower thermal neutron flux at BOC removes xenon-135 at a slower rate.
- C. smaller, because the lower fission rate at BOC produces xenon-135 at a slower rate.
- D. smaller, because the higher thermal neutron flux at BOC removes xenon-135 at a faster rate.

**USNRC GENERIC FUNDAMENTALS EXAMINATION  
DECEMBER 2012 BWR--FORM A**

QUESTION: 32

Gadolinium (Gd-155, Gd-157) is used instead of boron (B-10) as the \_\_\_\_\_ material; when compared to boron, gadolinium has a much \_\_\_\_\_ cross section for absorbing thermal neutrons.

- A. control rod; larger
- B. burnable poison; larger
- C. control rod; smaller
- D. burnable poison; smaller

QUESTION: 33

A nuclear power plant is initially shutdown with a  $K_{\text{eff}}$  of 0.92 and a stable source range count rate of 200 cps. Then a reactor startup is initiated. All control rod motion is stopped when  $K_{\text{eff}}$  equals 0.995. The instant that rod motion stops, source range count rate is 1,800 cps.

When source range count rate stabilizes, count rate will be approximately...

- A. 1,800 cps
- B. 2,400 cps
- C. 3,200 cps
- D. 3,600 cps



**USNRC GENERIC FUNDAMENTALS EXAMINATION  
DECEMBER 2012 BWR--FORM A**

QUESTION: 34

A reactor startup is in progress. Control rod withdrawal was stopped several minutes ago to assess criticality. Which one of the following is a combination of indications that together support a declaration that the reactor has reached criticality?

- A. Period is stable at positive 200 seconds; source range count rate is stable.
- B. Period is stable at infinity; source range count rate is stable.
- C. Period is stable at positive 200 seconds; source range count rate is slowly increasing.
- D. Period is stable at infinity; source range count rate is slowly increasing.

**USNRC GENERIC FUNDAMENTALS EXAMINATION  
DECEMBER 2012 BWR--FORM A**

QUESTION: 35

A reactor startup is in progress with the reactor at normal operating temperature and pressure. With reactor power stable at the point of adding heat, a control rod malfunction causes a short rod withdrawal that increases reactivity by  $0.14\% \Delta K/K$ .

Given:

- All control rod motion has stopped.
- No automatic system or operator actions occur to inhibit the power increase.
- Power coefficient equals  $-0.028\% \Delta K/K/\text{percent}$ .
- The effective delayed neutron fraction equals 0.006.

What is the approximate power level increase required to offset the reactivity added by the control rod withdrawal? (Ignore any reactivity effects from changes in fission product poisons.)

- A. 2.0 percent
- B. 5.0 percent
- C. 20 percent
- D. 50 percent

QUESTION: 36

During continuous reactor power operation, rod sequence exchanges are performed periodically to...

- A. ensure some control rods remain inserted as deep control rods until late in the fuel cycle.
- B. allow the local power range monitoring nuclear instruments to be asymmetrically installed in the core.
- C. increase the rod worth of control rods that are nearly fully withdrawn.
- D. prevent the development of individual control rods with very high reactivity worths.

**USNRC GENERIC FUNDAMENTALS EXAMINATION  
DECEMBER 2012 BWR--FORM A**

QUESTION: 37

Refer to the drawing of two water storage tanks with four differential pressure (D/P) level detectors (see figure below).

The tanks are identical and are being maintained at 2 psig overpressure, 60°F, and the same constant water level. The tanks are located within a sealed containment structure that is being maintained at standard atmospheric pressure. All level detectors have been calibrated and are producing the same level indication.

If a ventilation malfunction causes the containment structure pressure to decrease to 13 psia, which detectors will produce the highest level indications?

- A. 1 and 2
- B. 2 and 3
- C. 3 and 4
- D. 1 and 4

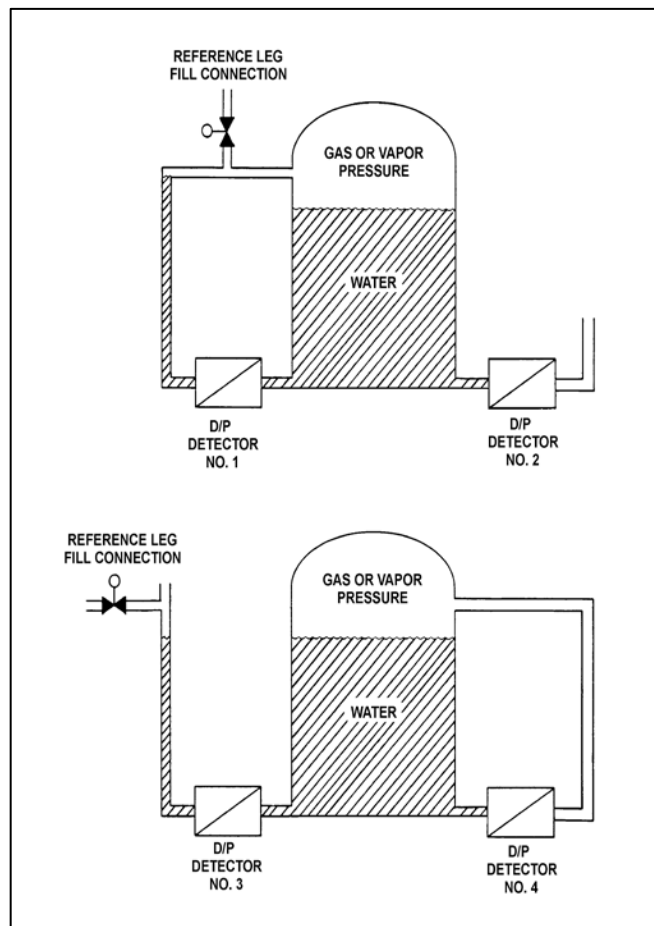

**USNRC GENERIC FUNDAMENTALS EXAMINATION  
DECEMBER 2012 BWR--FORM A**

QUESTION: 38

A nuclear power plant experienced a reactor scram. One hour after the scram, core cooling is being accomplished by relieving saturated steam from the reactor vessel (RV). Water level in the RV is being maintained by an operating feedwater pump. Average fuel temperature is stable.

Given the following current conditions:

Core decay heat rate = 33 MW  
RV pressure = 1,000 psia  
Feedwater temperature = 90°F

For the above conditions, approximately what feedwater flow rate is needed to maintain a constant mass of water in the RV?

- A. 100,000 lbm/hr
- B. 125,000 lbm/hr
- C. 170,000 lbm/hr
- D. 215,000 lbm/hr

QUESTION: 39

The steam inlet nozzles used in steam jet air ejectors convert the \_\_\_\_\_ of the steam into \_\_\_\_\_.

- A. enthalpy; pressure
- B. kinetic energy; velocity
- C. kinetic energy; pressure
- D. enthalpy; kinetic energy

**USNRC GENERIC FUNDAMENTALS EXAMINATION  
DECEMBER 2012 BWR--FORM A**

QUESTION: 40

A nuclear power plant is initially operating at steady-state 85 percent reactor power when the extraction steam to a high pressure feedwater heater is isolated. Compared to the initial main generator output (MW), after the plant is stabilized at 85 percent reactor power with the extraction steam isolated the main generator output (MW) will be...

- A. lower, because the steam cycle thermal efficiency has decreased.
- B. lower, because the steam mass flow rate through the main turbine has decreased.
- C. higher, because the steam cycle thermal efficiency has increased.
- D. higher, because the steam mass flow rate through the main turbine has increased.

QUESTION: 41

A nuclear power plant is operating at 100 percent power when a 200 gpm reactor vessel leak occurs, which results in a reactor scram and initiation of emergency coolant injection. Reactor vessel pressure stabilizes at 900 psia. All centrifugal injection pumps are operating with all pump miniflow paths isolated. The shutoff heads for the pumps are as follows:

High pressure coolant injection (HPCI) pumps = 800 psia  
Low pressure coolant injection (LPCI) pumps = 200 psia

If the injection pumps continue operating under these conditions, which pumps are likely to fail, and why?

- A. Only the LPCI pumps due to pump overheating.
- B. All LPCI and HPCI pumps due to pump overheating.
- C. Only the HPCI pumps due to motor overheating.
- D. All LPCI and HPCI pumps due to motor overheating.

**USNRC GENERIC FUNDAMENTALS EXAMINATION  
DECEMBER 2012 BWR--FORM A**

QUESTION: 42

A 55 gpm leak to atmosphere has developed from a cooling water system that is operating at 100 psig. Which one of the following will be the approximate leak rate when system pressure has decreased to 50 psig?

- A. 28 gpm
- B. 32 gpm
- C. 39 gpm
- D. 45 gpm

QUESTION: 43

The power range nuclear instruments have been adjusted to 100 percent based on a calculated heat balance. Which one of the following will result in indicated reactor power being lower than actual reactor power?

- A. The feedwater temperature used in the heat balance calculation was 10°F lower than actual feedwater temperature.
- B. The reactor recirculation pump heat input term was omitted from the heat balance calculation.
- C. The feedwater flow rate used in the heat balance calculation was 10 percent lower than actual feedwater flow rate.
- D. The steam pressure used in the heat balance calculation was 50 psi lower than actual steam pressure.

**USNRC GENERIC FUNDAMENTALS EXAMINATION  
DECEMBER 2012 BWR--FORM A**

QUESTION: 44

Which one of the following characteristics will enhance steam bubble formation in water adjacent to a heated surface?

- A. Chemicals dissolved in the water.
- B. The absence of ionizing radiation exposure to the water.
- C. A highly polished heat transfer surface with minimal scratches or cavities.
- D. The presence of gases dissolved in the water.

QUESTION: 45

Departure from nucleate boiling (DNB) occurs when steam bubbles begin to blanket the fuel rod, resulting in a rapid \_\_\_\_\_ in heat transfer rate and a rapid \_\_\_\_\_ in  $\Delta T$  (fuel cladding minus coolant temperature).

- A. decrease; increase
- B. decrease; decrease
- C. increase; increase
- D. increase; decrease

**USNRC GENERIC FUNDAMENTALS EXAMINATION  
DECEMBER 2012 BWR--FORM A**

QUESTION: 46

Given the following conditions for a 10 lbm steam-water mixture:

Steam quality = 40 percent  
Pressure = 1,000 psia

Which one of the following is the void fraction?

- A. 93.2 percent
- B. 89.9 percent
- C. 10.1 percent
- D. 6.8 percent

QUESTION: 47

Thermal limits are established to protect the reactor, and thereby protect the public during nuclear power plant operations, which include...

- A. normal operations only.
- B. normal and abnormal operations only.
- C. normal, abnormal, and postulated accident operations only.
- D. normal, abnormal, postulated and unpostulated accident operations.



**USNRC GENERIC FUNDAMENTALS EXAMINATION  
DECEMBER 2012 BWR--FORM A**

QUESTION: 48

Which one of the following causes a reduction in the size of the gap between the fuel pellets and the fuel cladding over core life.

- A. Contraction of the fuel rod due to zirconium hydriding.
- B. Expansion of the fuel pellets due to fission product buildup.
- C. Contraction of the fuel rod due to fuel rod internal vacuum.
- D. Expansion of the fuel pellets due to densification.

QUESTION: 49

Gross cladding failure is avoided during a design basis loss of coolant accident by operation below the limit for...

- A. total peaking factor.
- B. linear heat generation rate.
- C. operating critical power ratio.
- D. average planar linear heat generation rate.

**USNRC GENERIC FUNDAMENTALS EXAMINATION  
DECEMBER 2012 BWR--FORM A**

QUESTION: 50

A reactor is shut down for refueling following 18 months of operation at an average power level of 85 percent. During the shutdown, a reactor vessel metal specimen was removed from the reactor vessel for testing. The tests determined that the nil-ductility transition (NDT) temperature of the specimen increased from 42°F to 72°F since the previous refueling shutdown.

Which one of the following conclusions is warranted?

- A. The test results are credible and the reactor vessel is more likely to experience brittle fracture now than after the previous refueling shutdown.
- B. The test results are credible and the reactor vessel is less likely to experience brittle fracture now than after the previous refueling shutdown.
- C. The test results are questionable because the specimen NDT temperature would not increase during the described 18-month period of operation.
- D. The test results are questionable because the specimen NDT temperature would increase by less than indicated during the described 18-month period of operation.

**\*\*\* FINAL ANSWER KEY \*\*\***

**DECEMBER 2012 NRC GENERIC FUNDAMENTALS EXAMINATION  
BOILING WATER REACTOR - ANSWER KEY**

<u>FORM A</u>	<u>FORM B</u>	<u>ANS.</u>	<u>FORM A</u>	<u>FORM B</u>	<u>ANS.</u>
1	15	B	26	40	B
2	16	D	27	41	D
3	17	A	28	42	B
4	18	C	29	43	A
5	19	C	30	44	C
6	20	C	31	45	B
7	21	C	32	46	B
8	22	B	33	47	C
9	23	D	34	48	C
10	24	A	35	49	B
11	25	B	36	50	D
12	26	D	37	1	B
13	27	D	38	2	A
14	28	D	39	3	D
15	29	A	40	4	A
16	30	C	41	5	B
17	31	B	42	6	C
18	32	B	43	7	C
19	33	D	44	8	D
20	34	D	45	9	A
21	35	A	46	10	A
22	36	A	47	11	C
23	37	C	48	12	B
24	38	A	49	13	D
25	39	A	50	14	D