

**UNITED STATES NUCLEAR REGULATORY COMMISSION
BOILING WATER REACTOR GENERIC FUNDAMENTALS EXAMINATION
SEPTEMBER 2012--FORM A**

Please Print

Name: _____

Docket No.: _____

Facility: _____

Start Time: _____ Stop Time: _____

INSTRUCTIONS TO APPLICANT

Answer all the test items using the answer sheet provided, ensuring a single answer is marked for each test item. Each test item has equal point value. A score of at least 80 percent is required to pass this portion of the NRC operator licensing written examination. All examination materials will be collected 3 hours after the examination begins. This examination applies to a typical U.S. boiling water reactor (BWR) nuclear power plant.

SECTION	QUESTIONS	% OF TOTAL	SCORE
COMPONENTS	1 - 22		
REACTOR THEORY	23 - 36		
THERMODYNAMICS	37 - 50		
TOTALS	50		

All work performed on this examination is my own. I have neither given nor received aid.

Applicant's Signature

**RULES AND INSTRUCTIONS FOR THE NRC
GENERIC FUNDAMENTALS EXAMINATION**

During the administration of this examination the following rules apply:

NOTE: The term "control rod" refers to the length of neutron absorber material that can be positioned by the operator to change core reactivity.

NOTE: Numerical answers are rounded to the nearest whole number unless otherwise indicated.

1. Print your name in the blank provided on the cover sheet of the examination.
2. Fill in your individual docket number.
3. Fill in the name of your facility.
4. Fill in your start and stop times at the appropriate times.
5. Two aids are provided for your use during the examination:
 - (1) An equations and conversions sheet contained within the examination copy, and
 - (2) Steam tables and Mollier Diagram provided by your proctor.
6. Place your answers on the answer sheet provided. Credit will only be given for answers properly marked on this sheet. Follow the instructions for filling out the answer sheet.
7. Scrap paper will be provided for calculations.
8. Cheating on the examination will result in the automatic forfeiture of this examination. Cheating could also result in severe penalties.
9. Restroom trips are limited. Only **one** examinee may leave the room at a time. In order to avoid the appearance or possibility of cheating, avoid all contact with anyone outside of the examination room.
10. After you have completed the examination, sign the statement on the cover sheet indicating that the work is your own and you have neither given nor received any assistance in completing the examination. Either pencil or pen may be used.
11. Turn in your examination materials, answer sheet on top, followed by the examination copy and the examination aids, e.g., steam tables, handouts, and scrap paper.
12. After turning in your examination materials, leave the examination area, as defined by the proctor. If after leaving you are found in the examination area while the examination is in progress, your examination may be forfeited.

**GENERIC FUNDAMENTALS EXAMINATION
EQUATIONS AND CONVERSIONS HANDOUT SHEET**

EQUATIONS

$$\dot{Q} = \dot{m}c_p\Delta T$$

$$\dot{Q} = \dot{m}\Delta h$$

$$\dot{Q} = UA\Delta T$$

$$\dot{Q} \propto \dot{m}_{\text{Nat Circ}}^3$$

$$\Delta T \propto \dot{m}_{\text{Nat Circ}}^2$$

$$K_{\text{eff}} = 1/(1 - \rho)$$

$$\rho = (K_{\text{eff}} - 1)/K_{\text{eff}}$$

$$\text{SUR} = 26.06/\tau$$

$$\tau = \frac{\bar{\beta}_{\text{eff}} - \rho}{\lambda_{\text{eff}} \rho}$$

$$\rho = \frac{\ell^*}{\tau} + \frac{\bar{\beta}_{\text{eff}}}{1 + \lambda_{\text{eff}} \tau}$$

$$\ell^* = 1 \times 10^{-4} \text{ sec}$$

$$\lambda_{\text{eff}} = 0.1 \text{ sec}^{-1} \text{ (for small positive } \rho \text{)}$$

$$\text{DRW} \propto \phi_{\text{tip}}^2 / \phi_{\text{avg}}^2$$

$$A = A_0 e^{-\lambda t}$$

$$P = P_0 10^{\text{SUR}(t)}$$

$$P = P_0 e^{(t/\tau)}$$

$$\text{CR}_{\text{S/D}} = S/(1 - K_{\text{eff}})$$

$$\text{CR}_1(1 - K_{\text{eff}1}) = \text{CR}_2(1 - K_{\text{eff}2})$$

$$1/M = \text{CR}_1/\text{CR}_x$$

$$A = \pi r^2$$

$$F = PA$$

$$\dot{m} = \rho A \bar{v}$$

$$\dot{W}_{\text{Pump}} = \dot{m}\Delta P v$$

$$P = IE$$

$$P_A = \sqrt{3} IE$$

$$P_T = \sqrt{3} IE \text{ pf}$$

$$P_R = \sqrt{3} IE \sin\theta$$

$$\text{Thermal Efficiency} = \text{Net Work Out}/\text{Energy In}$$

$$\frac{g(z_2 - z_1)}{g_c} + \frac{(\bar{v}_2^2 - \bar{v}_1^2)}{2g_c} + v(P_2 - P_1) + (u_2 - u_1) + (q - w) = 0$$

$$g_c = 32.2 \text{ lbm-ft/lbf-sec}^2$$

CONVERSIONS

$$1 \text{ Mw} = 3.41 \times 10^6 \text{ Btu/hr}$$

$$1 \text{ hp} = 2.54 \times 10^3 \text{ Btu/hr}$$

$$1 \text{ Btu} = 778 \text{ ft-lbf}$$

$$^\circ\text{C} = (5/9)(^\circ\text{F} - 32)$$

$$^\circ\text{F} = (9/5)(^\circ\text{C}) + 32$$

$$1 \text{ kg} = 2.21 \text{ lbm}$$

$$1 \text{ ft}^3_{\text{water}} = 7.48 \text{ gal}$$

$$1 \text{ gal}_{\text{water}} = 8.35 \text{ lbm}$$

$$1 \text{ Curie} = 3.7 \times 10^{10} \text{ dps}$$

**USNRC GENERIC FUNDAMENTALS EXAMINATION
SEPTEMBER 2012 BWR--FORM A**

QUESTION: 1

Refer to the drawing of two identical water storage tanks (see figure below). Tank A is protected by a relief valve and Tank B is protected by a safety valve. Each valve has an opening setpoint of 205 psig and a maximum rated discharge flow rate of 8 gpm.

The tanks are being hydrostatically tested to 200 psig. Each tank is being supplied with a smooth and constant flow rate of 2 gpm from separate positive displacement pumps (PDPs). Both PDPs are inadvertently left running when tank pressures reach 200 psig.

With the PDPs running continuously, what will be the resulting status of the relief and safety valves?

- | | <u>Relief Valve Status</u> | <u>Safety Valve Status</u> |
|----|---------------------------------------------|---------------------------------------------|
| A. | Partially open | Partially open |
| B. | Partially open | Cycling between fully open and fully closed |
| C. | Cycling between fully open and fully closed | Partially open |
| D. | Cycling between fully open and fully closed | Cycling between fully open and fully closed |

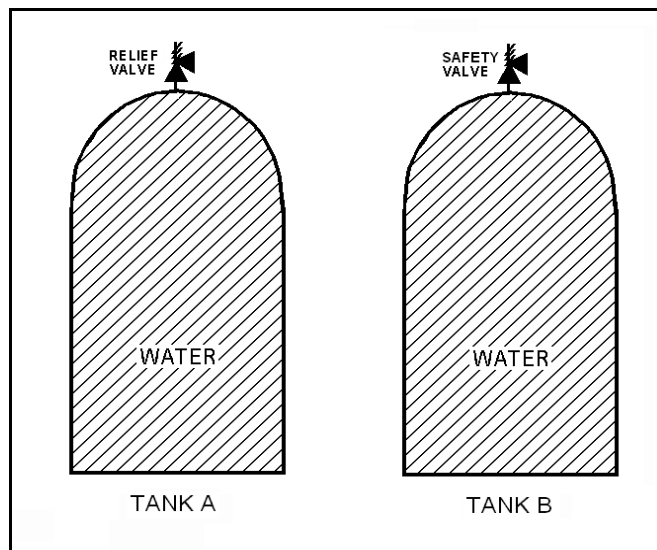

**USNRC GENERIC FUNDAMENTALS EXAMINATION
SEPTEMBER 2012 BWR--FORM A**

QUESTION: 2

Subcooled water is flowing through a throttled valve in an open system. The initial steady-state conditions for the throttled valve are as follows:

- Inlet pressure = 60 psia
- Outlet pressure = 44 psia
- Flow rate = 800 gpm

After four hours, the current steady-state conditions for the throttled valve are as follows:

- Inlet pressure = 62 psia
- Outlet pressure = 40 psia
- Flow rate = 600 gpm

Which one of the following could be responsible for the difference between the initial and current conditions for the throttled valve?

- A. The throttled valve was opened more.
- B. The throttled valve was closed more.
- C. Another valve, located upstream of the throttled valve, was partially closed.
- D. Another valve, located downstream of the throttled valve, was partially closed.

**USNRC GENERIC FUNDAMENTALS EXAMINATION
SEPTEMBER 2012 BWR--FORM A**

QUESTION: 3

In a comparison between ball valves and butterfly valves in the same water system application, the valve that typically would allow more leakage when fully closed and under high differential pressure is the _____ valve; and the valve that typically would cause the greater pressure loss when fully open is the _____ valve.

- A. ball; butterfly
- B. ball; ball
- C. butterfly; butterfly
- D. butterfly; ball

QUESTION: 4

Density input is normally used in steam flow instruments to convert _____ into _____.

- A. mass flow rate; volumetric flow rate
- B. volumetric flow rate; mass flow rate
- C. mass flow rate; differential pressure
- D. differential pressure; volumetric flow rate

**USNRC GENERIC FUNDAMENTALS EXAMINATION
SEPTEMBER 2012 BWR--FORM A**

QUESTION: 5

Refer to the drawing of a water storage tank with a differential pressure D/P level detection system (see figure below).

The level detector is being used in a level control system that was calibrated to maintain tank level at 80 percent when the tank temperature was 100°F. If tank temperature gradually increases and stabilizes at 150°F, actual tank level will...

- A. remain stable at 80 percent.
- B. increase and stabilize above 80 percent.
- C. oscillate and then stabilize at 80 percent.
- D. decrease and stabilize below 80 percent.

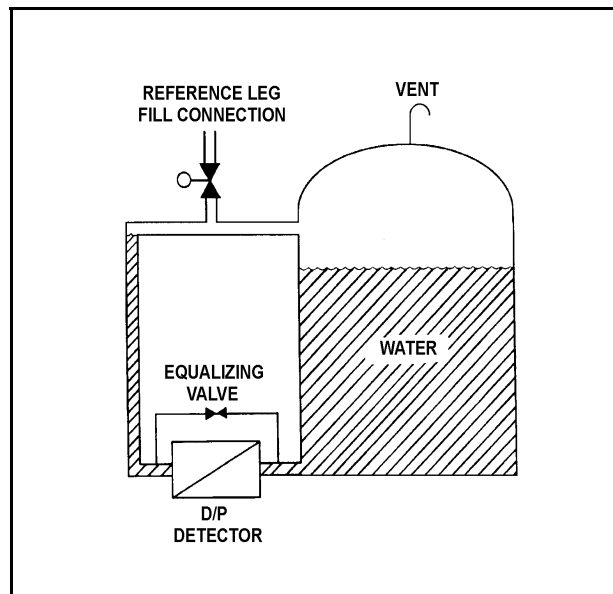

**USNRC GENERIC FUNDAMENTALS EXAMINATION
SEPTEMBER 2012 BWR--FORM A**

QUESTION: 6

Fission chamber detectors are used to monitor reactor power/neutron level in a shutdown reactor as well as a reactor operating at rated power (and all power levels in between). At what power level(s) is it necessary to compensate the output of the fission chamber detectors for gamma interactions with the detectors, and why?

- A. At all power levels, because gamma interactions produce larger detector pulses than neutron interactions.
- B. At all power levels, because gamma interactions produce smaller detector pulses than neutron interactions.
- C. Only when shutdown or at low power levels, because gamma flux is not proportional to reactor power at low power levels.
- D. Only when operating at high power levels, because gamma flux is not proportional to reactor power at high power levels.

QUESTION: 7

DELETED

**USNRC GENERIC FUNDAMENTALS EXAMINATION
SEPTEMBER 2012 BWR--FORM A**

QUESTION: 8

Refer to the valve controller logic diagram (see figure below).

Which one of the following combinations of inputs will result in the valve receiving an open signal?

	INPUTS			
	1.	2.	3.	4.
A.	On	Off	On	On
B.	Off	On	Off	Off
C.	On	Off	Off	On
D.	Off	On	On	Off

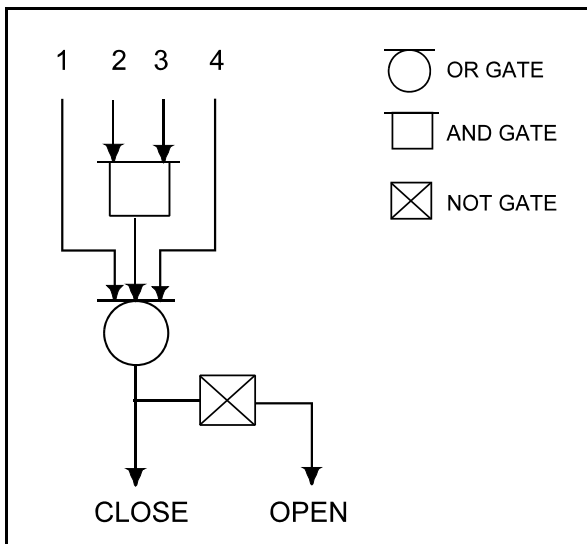

**USNRC GENERIC FUNDAMENTALS EXAMINATION
SEPTEMBER 2012 BWR--FORM A**

QUESTION: 9

A proportional controller is being used to control the water level in a tank. When the tank water level matches the controller setpoint of 50%, the controller output signal is 50%.

Tank water level begins to rise, and the controller stabilizes water level at 60%, at which time the controller output signal is 90%.

What is the offset for this controller at the 60% water level?

- A. 10%
- B. 30%
- C. 40%
- D. 67%

QUESTION: 10

By starting a centrifugal pump with the discharge valve throttled versus fully open, the possibility of pump runout is _____ and the possibility of pump cavitation is _____.

- A. increased; increased
- B. increased; decreased
- C. decreased; increased
- D. decreased; decreased

**USNRC GENERIC FUNDAMENTALS EXAMINATION
SEPTEMBER 2012 BWR--FORM A**

QUESTION: 11

Refer to the drawing of an operating cooling water system (see figure below).

Which one of the following changes to the cooling water system will result in a lower cooling water pump flow rate and a higher pump discharge head?

- A. Decrease pump speed by 20 percent.
- B. Increase pump speed by 20 percent.
- C. Isolate one of the two in-service heat loads.
- D. Place the third system heat load in service.

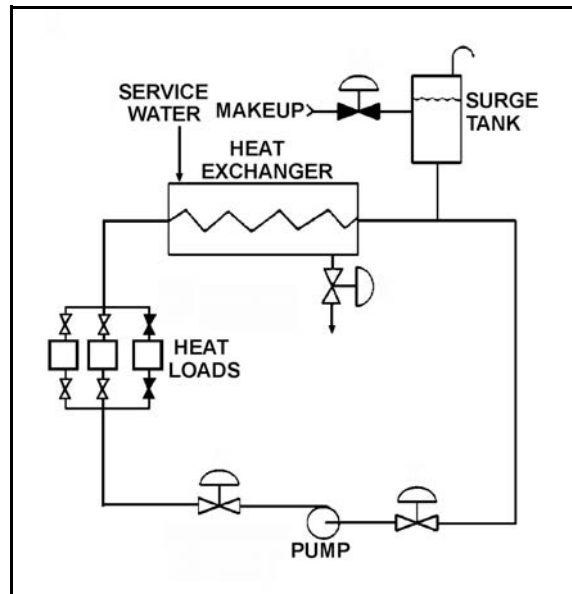

**USNRC GENERIC FUNDAMENTALS EXAMINATION
SEPTEMBER 2012 BWR--FORM A**

QUESTION: 12

Refer to the drawing of centrifugal pump and system operating curves (see figure below).

Which one of the following describes the value of head where the two curves cross?

- A. The maximum amount of head that the pump can provide.
- B. The amount of pump head that is required to avoid cavitation.
- C. The amount of pump head that is converted to kinetic energy in the pump.
- D. The amount of pump head that is converted to heat and other losses as the water circulates through the system.

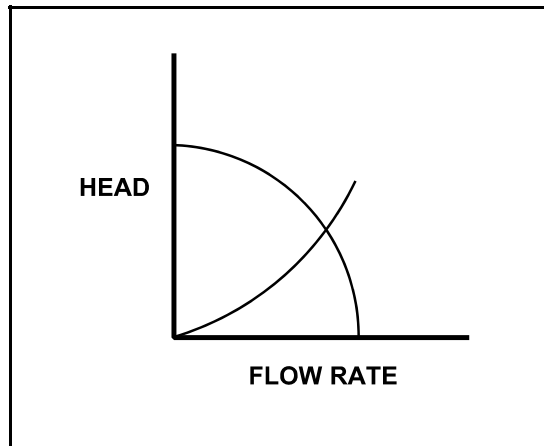

**USNRC GENERIC FUNDAMENTALS EXAMINATION
SEPTEMBER 2012 BWR--FORM A**

QUESTION: 13

An ideal (no slip) reciprocating positive displacement pump is operating to provide makeup water to a reactor coolant system that is being maintained at 1,000 psig. The discharge valve of the pump was found to be throttled to 80 percent open.

If the valve is subsequently fully opened, pump flow rate will _____ and pump head will _____.

- A. increase; decrease
- B. remain constant; decrease
- C. increase; remain constant
- D. remain constant; remain constant

QUESTION: 14

For large electric motors, why must the number of starts during a specified period of time be limited?

- A. To protect the power supply cables from insulation breakdown due to high starting current.
- B. To protect the motor windings from overheating.
- C. To prevent motor thrust bearing damage due to lack of lubrication.
- D. To prevent rotor seizure due to thermal expansion of the windings.

**USNRC GENERIC FUNDAMENTALS EXAMINATION
SEPTEMBER 2012 BWR--FORM A**

QUESTION: 15

A main generator is connected to an infinite power grid. Which one of the following pairs of main generator output parameters places the generator in the closest proximity to slipping a pole.

- A. 800 MW; 200 MVAR (in)
- B. 800 MW; 600 MVAR (in)
- C. 400 MW; 200 MVAR (out)
- D. 400 MW; 600 MVAR (out)

QUESTION: 16

Refer to the drawing of an operating parallel-flow lube oil heat exchanger (see figure below).

Unlike a counter-flow heat exchanger, in the parallel-flow heat exchanger the _____ temperature will always be greater than the _____ temperature.

- A. CW outlet; LO inlet
- B. CW outlet; LO outlet
- C. LO outlet; CW inlet
- D. LO outlet; CW outlet

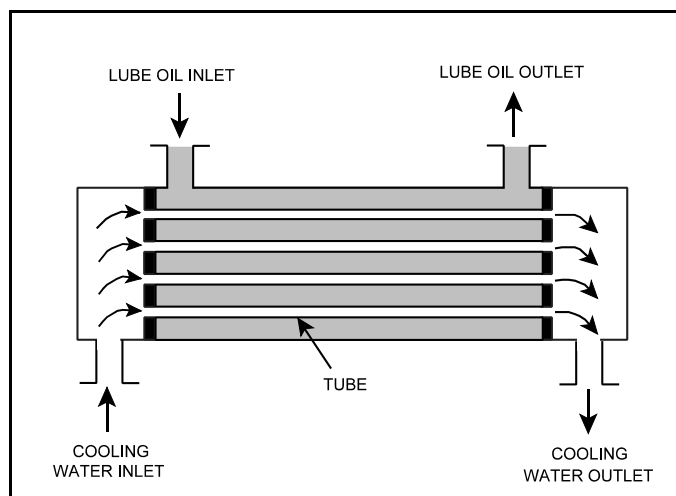

**USNRC GENERIC FUNDAMENTALS EXAMINATION
SEPTEMBER 2012 BWR--FORM A**

QUESTION: 17

Refer to the drawing of two system curves for a typical main condenser cooling water system (see figure below).

Which one of the following will cause the system curve to shift from the solid curve toward the dashed curve?

- A. The main condenser tubes are cleaned.
- B. The main condenser tubes become increasingly fouled.
- C. Cooling water flow rate is increased by 25 percent by starting an additional cooling water pump.
- D. Cooling water flow rate is decreased by 25 percent by stopping one of the operating cooling water pumps.

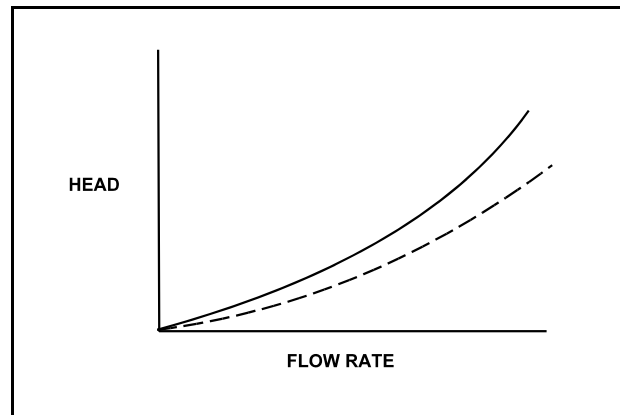

**USNRC GENERIC FUNDAMENTALS EXAMINATION
SEPTEMBER 2012 BWR--FORM A**

QUESTION: 18

Refer to the drawing of an operating lube oil heat exchanger (see figure below).

The heat exchanger is operating with the following initial parameters:

Cooling water inlet temperature (T_{cw-in})	= 75°F
Cooling water outlet temperature (T_{cw-out})	= 95°F
Oil inlet temperature (T_{oil-in})	= 150°F
Oil outlet temperature ($T_{oil-out}$)	= 120°F

Air introduction to the heat exchanger results in some of the heat exchanger tubes becoming uncovered. As a result, T_{cw-out} decreases to 91°F. Assume the inlet temperatures, mass flow rates, and specific heats of both fluids do not change.

Which one of the following will be the resulting temperature of the oil exiting the heat exchanger ($T_{oil-out}$)?

- A. 126°F
- B. 130°F
- C. 134°F
- D. 138°F

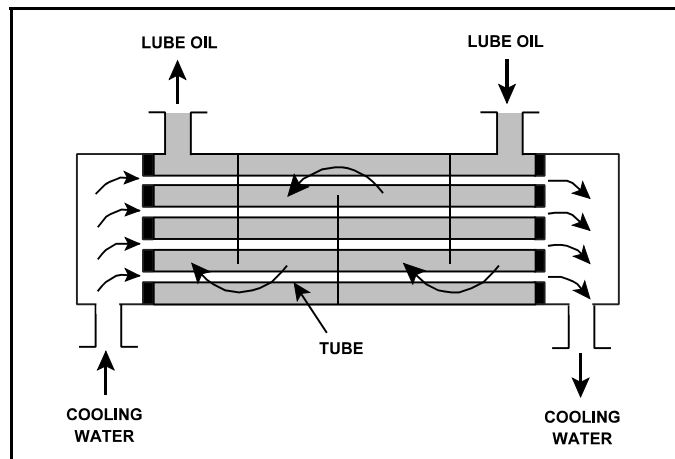

**USNRC GENERIC FUNDAMENTALS EXAMINATION
SEPTEMBER 2012 BWR--FORM A**

QUESTION: 19

High differential pressure in a demineralizer could be caused by all of the following except...

- A. resin exhaustion.
- B. resin overheating.
- C. crud buildup.
- D. high flow rate.

QUESTION: 20

The cation exchange resin in a mixed-bed demineralizer removes undesirable _____ ions from solution while releasing desirable _____ ions into solution.

- A. negative; negative
- B. negative; positive
- C. positive; negative
- D. positive; positive

**USNRC GENERIC FUNDAMENTALS EXAMINATION
SEPTEMBER 2012 BWR--FORM A**

QUESTION: 21

A typical 120 VAC manual circuit breaker tripped due to overload. To close this circuit breaker, the handle must be moved from the...

- A. OFF position directly to the ON position; trip latch reset is not required.
- B. midposition directly to the ON position; trip latch reset is not required.
- C. OFF position to the midposition to reset the trip latch, and then to the ON position.
- D. midposition to the OFF position to reset the trip latch, and then to the ON position.

**USNRC GENERIC FUNDAMENTALS EXAMINATION
SEPTEMBER 2012 BWR--FORM A**

QUESTION: 22

Refer to the drawing of a valve control circuit (see figure below).

Note: Limit switch (LS) contacts are shown open regardless of valve position, but relay contacts are shown open/closed according to the standard convention for control circuit drawings.

Which one of the following will actuate the alarm?

- A. With the valve partially closed, the control switch is taken to the CLOSE position.
- B. With the valve partially closed, the control switch is taken to the OPEN position.
- C. With the valve fully open, the control switch is taken to the CLOSE position.
- D. With the valve fully open, the control switch is taken to the OPEN position.

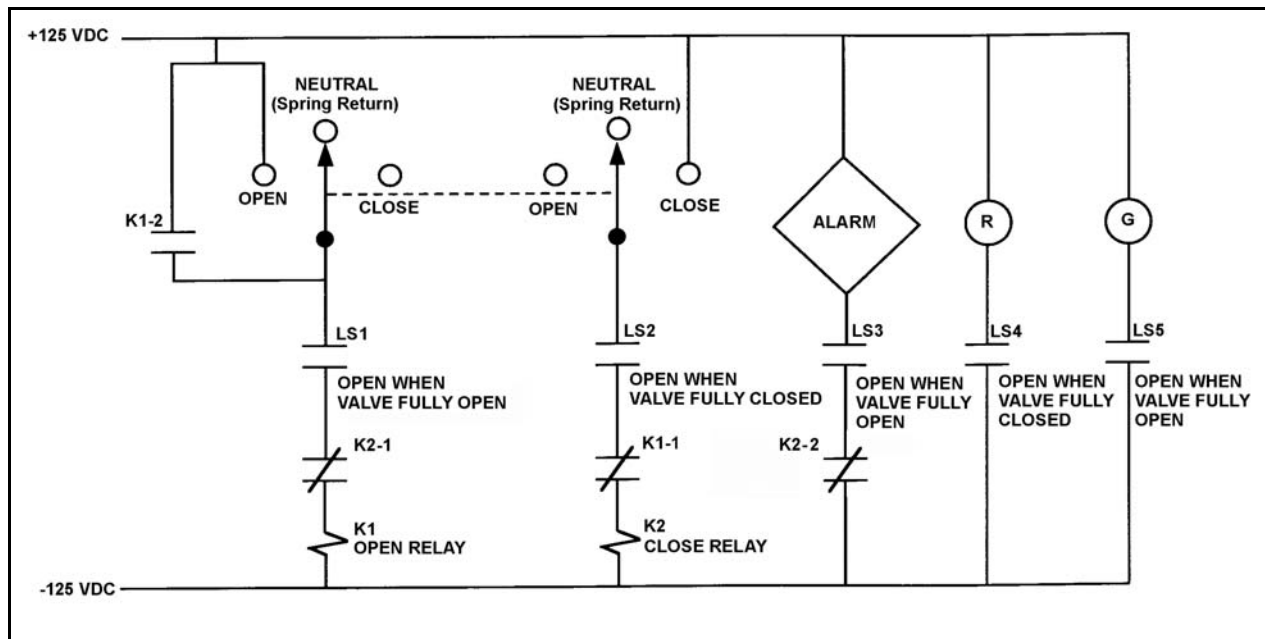

**USNRC GENERIC FUNDAMENTALS EXAMINATION
SEPTEMBER 2012 BWR--FORM A**

QUESTION: 23

A thermal neutron exists at an energy _____ the epithermal range and its cross section for absorption in U-235 _____ as the neutron energy decreases.

- A. above; decreases
- B. above; increases
- C. below; decreases
- D. below; increases

QUESTION: 24

Nuclear reactors A and B are identical except that reactor A is operating near the beginning of a fuel cycle (BOC) and reactor B is operating near the end of a fuel cycle (EOC). Both reactors are operating at 100 percent power.

Which reactor would have the smaller K_{eff} five minutes after a reactor scram?

- A. Reactor A, because the control rods will add more negative reactivity near the BOC.
- B. Reactor A, because the power coefficient is more negative near the BOC.
- C. Reactor B, because the control rods will add more negative reactivity near the EOC.
- D. Reactor B, because the power coefficient is more negative near the EOC.

**USNRC GENERIC FUNDAMENTALS EXAMINATION
SEPTEMBER 2012 BWR--FORM A**

QUESTION: 25

A nuclear reactor is operating at steady-state 100 percent power in the middle of a fuel cycle. Which one of the following changes would cause the core effective delayed neutron fraction to increase?

- A. The fast nonleakage factor increases.
- B. The fast nonleakage factor decreases.
- C. The thermal utilization factor increases.
- D. The thermal utilization factor decreases.

QUESTION: 26

Which one of the following describes the overall reactivity effect of a moderator temperature decrease in an overmoderated reactor core?

- A. Positive reactivity will be added because fewer neutrons will be captured by the moderator.
- B. Positive reactivity will be added because fewer neutrons will be absorbed at resonance energies while slowing down.
- C. Negative reactivity will be added because more neutrons will be captured by the moderator.
- D. Negative reactivity will be added because more neutrons will be absorbed at resonance energies while slowing down.

**USNRC GENERIC FUNDAMENTALS EXAMINATION
SEPTEMBER 2012 BWR--FORM A**

QUESTION: 27

Compared to beginning of core life, the fuel temperature coefficient is _____ negative at end of core life due to _____. (Assume the same initial fuel temperature throughout the fuel cycle.)

- A. less; depletion of U-238
- B. more; burnup of gadolinium
- C. less; buildup of fission products
- D. more; buildup of Pu-240

QUESTION: 28

A control rod is positioned in a nuclear reactor with the following neutron flux parameters:

$$\begin{aligned}\text{Core average thermal neutron flux} &= 1.0 \times 10^{12} \text{ n/cm}^2\text{-sec} \\ \text{Control rod tip thermal neutron flux} &= 4.0 \times 10^{12} \text{ n/cm}^2\text{-sec}\end{aligned}$$

If the control rod is slightly inserted such that the control rod tip is located in a thermal neutron flux of 1.6×10^{13} n/cm²-sec, the differential control rod worth will increase by a factor of _____. (Assume the core average thermal neutron flux is constant.)

- A. 2
- B. 4
- C. 8
- D. 16

**USNRC GENERIC FUNDAMENTALS EXAMINATION
SEPTEMBER 2012 BWR--FORM A**

QUESTION: 29

Which one of the following control rods, when repositioned by 2 notches, will have the greatest effect on the axial neutron flux shape?

- A. Deep rod at the center of the core
- B. Deep rod at the periphery of the core
- C. Shallow rod at the center of the core
- D. Shallow rod at the periphery of the core

QUESTION: 30

A reactor scram occurred one hour ago following several months of operation at 100 percent power. Reactor vessel pressure is being maintained at 800 psia and the source range count rate is currently 400 cps. If no operator action is taken, how will the source range count rate respond during the next 24 hours? (Assume a constant source neutron flux.)

- A. The count rate will remain about the same.
- B. The count rate will decrease for the entire period.
- C. The count rate will initially decrease and then increase.
- D. The count rate will initially increase and then decrease.

**USNRC GENERIC FUNDAMENTALS EXAMINATION
SEPTEMBER 2012 BWR--FORM A**

QUESTION: 31

A reactor is initially operating at 50 percent power with equilibrium core xenon-135. Power is increased to 75 percent over a 1 hour period with no subsequent operator actions. Considering only the reactivity effects of core xenon-135 changes, which one of the following describes reactor power 6 hours after the power change?

- A. Greater than 75 percent and decreasing slowly.
- B. Greater than 75 percent and increasing slowly.
- C. Lower than 75 percent and decreasing slowly.
- D. Lower than 75 percent and increasing slowly.

QUESTION: 32

Why are burnable poisons installed in a nuclear reactor core?

- A. To shield reactor fuel from thermal neutron flux until later in core life.
- B. To compensate for control rod burnout that occurs over core life.
- C. To flatten the radial thermal neutron flux distribution at the end of core life.
- D. To ensure a negative moderator temperature coefficient early in core life.

**USNRC GENERIC FUNDAMENTALS EXAMINATION
SEPTEMBER 2012 BWR--FORM A**

QUESTION: 33

As a nuclear reactor approaches criticality during a reactor startup, it takes longer to reach an equilibrium neutron level after each control rod withdrawal due to the increased...

- A. length of time required to complete a neutron generation.
- B. number of neutron generations required to reach a stable neutron level.
- C. length of time from neutron birth to absorption.
- D. fraction of delayed neutrons being produced.

QUESTION: 34

After taking critical data during a reactor startup, the operator establishes a positive 48-second reactor period to increase reactor power to the point of adding heat (POAH). Which one of the following is the approximate amount of reactivity needed to stabilize power at the POAH? (Assume $\bar{\beta}_{\text{eff}} = 0.00579$.)

- A. +0.10 % Δ K/K
- B. +0.12 % Δ K/K
- C. -0.10 % Δ K/K
- D. -0.12 % Δ K/K

**USNRC GENERIC FUNDAMENTALS EXAMINATION
SEPTEMBER 2012 BWR--FORM A**

QUESTION: 35

Which one of the following is responsible for the negative 80-second stable reactor period observed after a reactor scram?

- A. The shortest-lived delayed neutron precursors.
- B. The longest-lived delayed neutron precursors.
- C. The shutdown margin just prior to the scram.
- D. The worth of the inserted control rods.

QUESTION: 36

A nuclear reactor initially has a K_{eff} of 0.999 and a stable source range count rate. Control rods are inserted until K_{eff} decreases to 0.998, resulting in a negative reactor period. After the control rod insertion stops, reactor period will...

- A. gradually lengthen until the neutron population reaches equilibrium, then stabilize at infinity.
- B. gradually lengthen until the neutron population reaches equilibrium, then stabilize at an unknown negative value.
- C. quickly stabilize at approximately negative 80 seconds until the neutron population approaches equilibrium, then gradually lengthen and stabilize at infinity.
- D. quickly stabilize at an unknown negative value until the neutron population approaches equilibrium, then gradually lengthen and stabilize at an unknown negative value.

**USNRC GENERIC FUNDAMENTALS EXAMINATION
SEPTEMBER 2012 BWR--FORM A**

QUESTION: 37

Refer to the drawing of two water storage tanks with four differential pressure (D/P) level detectors (see figure below).

The tanks are identical with equal water levels and 20 psia gas pressure above the water. The tanks are surrounded by standard atmospheric pressure. The temperature of the water in the tanks and reference legs is 70°F.

If each detector experiences a ruptured diaphragm, which detector(s) will produce a higher level indication? (Assume that actual tank and reference leg water levels do not change.)

- A. No. 1 only
- B. No. 2 only
- C. No. 1 and 3
- D. No. 2 and 4

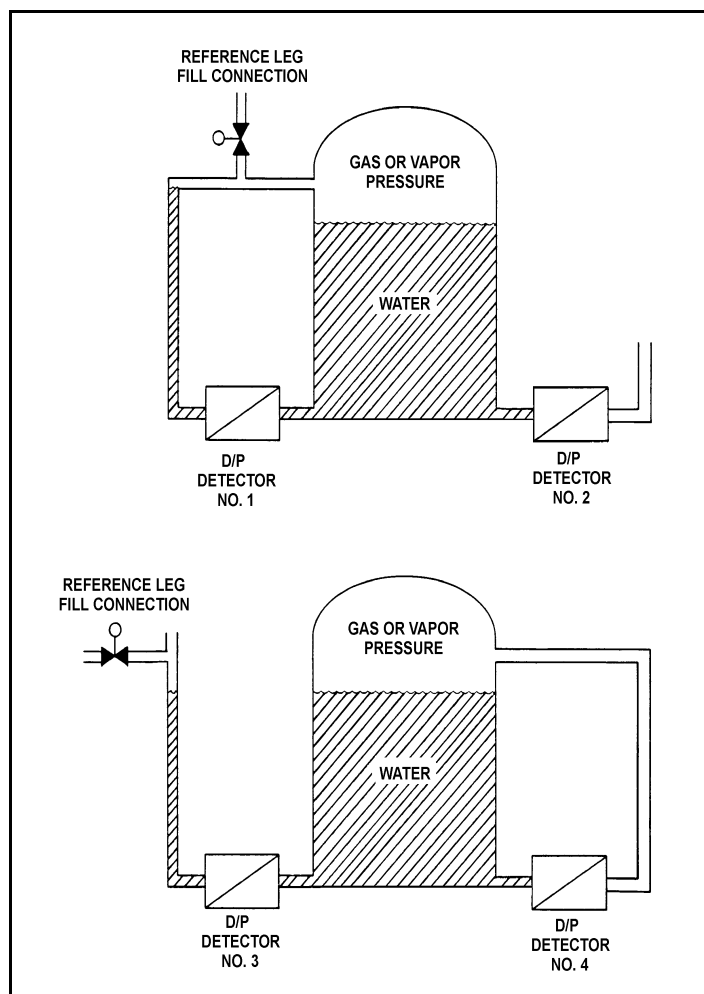

**USNRC GENERIC FUNDAMENTALS EXAMINATION
SEPTEMBER 2012 BWR--FORM A**

QUESTION: 38

Saturated steam at 1,000 psia enters an ideal high pressure (HP) turbine and exhausts at 100 psia. The HP turbine exhaust then enters an ideal low pressure (LP) turbine and exhausts to a steam condenser at 1.5 psia. Which one of the following will cause the HP and LP turbines to produce more equal power? (Assume all pressures remain the same unless stated otherwise.)

- A. Reheat the HP turbine exhaust.
- B. Lower the steam condenser pressure.
- C. Remove the moisture from the HP turbine exhaust.
- D. Decrease the pressure of the saturated steam entering the HP turbine.

QUESTION: 39

A nuclear power plant is operating at 100 percent power. Which one of the following describes how and why main condenser pressure will change if condenser cooling water flow rate increases significantly?

- A. Decreases because main condenser saturation temperature decreases.
- B. Decreases because main condenser condensate subcooling increases.
- C. Increases because main condenser saturation temperature decreases.
- D. Increases because main condenser condensate subcooling increases.

**USNRC GENERIC FUNDAMENTALS EXAMINATION
SEPTEMBER 2012 BWR--FORM A**

QUESTION: 40

A main turbine consists of a high pressure (HP) unit and several low pressure (LP) units. The main turbine is most likely to experience stress-related failures of the rotor blades in the _____ stages of the _____ unit(s).

- A. inlet; HP
- B. inlet; LP
- C. outlet; HP
- D. outlet; LP

QUESTION: 41

Water at 90°F and 50 psig is flowing through a 10-inch diameter pipe at 100 lbm/sec. The pipe then splits into two pipes, a 6-inch diameter pipe and an 8-inch diameter pipe.

Disregarding any flow restrictions other than pipe size, which one of the following lists the approximate flow rates through the 6-inch and 8-inch diameter pipes?

- | | 6-inch Pipe
<u>(lbm/sec)</u> | 8-inch Pipe
<u>(lbm/sec)</u> |
|----|---------------------------------|---------------------------------|
| A. | 24 | 76 |
| B. | 32 | 68 |
| C. | 36 | 64 |
| D. | 40 | 60 |

**USNRC GENERIC FUNDAMENTALS EXAMINATION
SEPTEMBER 2012 BWR--FORM A**

QUESTION: 42

An 80 gpm leak to atmosphere has developed from a cooling water system that is operating at 150 psig. Which one of the following will be the approximate leak rate when system pressure has decreased to 100 psig?

- A. 70 gpm
- B. 65 gpm
- C. 53 gpm
- D. 47 gpm

QUESTION: 43

Which one of the following pairs of fluids undergoing heat transfer in typical cross-flow heat exchangers will yield the greatest heat exchanger overall heat transfer coefficient? (Assume comparable heat exchanger sizes and fluid flow rates.)

- A. Oil to water in a lube oil cooler.
- B. Air to water in an air compressor after-cooler.
- C. Water to water in a cooling water heat exchanger.
- D. Steam to water in a turbine exhaust steam condenser.

**USNRC GENERIC FUNDAMENTALS EXAMINATION
SEPTEMBER 2012 BWR--FORM A**

QUESTION: 44

Which one of the following conditions must occur to sustain natural convection in a fluid system?

- A. Subcooling of the fluid.
- B. A phase change in the fluid.
- C. An enthalpy change in the fluid.
- D. Radiative heat transfer to the fluid.

QUESTION: 45

Which one of the following describes the onset of transition boiling?

- A. Steam bubbles begin to blanket the fuel rod causing a rapid increase in the ΔT between the fuel rod and the coolant.
- B. Steam bubbles completely blanket the fuel rod causing an increase in the heat flux from the fuel rod.
- C. Steam bubbles begin to blanket the fuel rod causing a rapid decrease in ΔT between the fuel rod and the coolant.
- D. Steam bubbles break up the laminar layer of coolant on the surface of the fuel rod causing an increase in the heat flux from the fuel rod.

**USNRC GENERIC FUNDAMENTALS EXAMINATION
SEPTEMBER 2012 BWR--FORM A**

QUESTION: 46

Refer to the drawing of a fuel rod and coolant flow channel at the beginning of a fuel cycle (see figure below).

At 100 percent reactor power, the greatest temperature difference in a fuel channel radial temperature profile will occur across the...

- A. fuel pellet centerline to pellet surface.
- B. fuel pellet surface-to-clad gap.
- C. zircaloy cladding.
- D. flow channel boundary (laminar) layer.

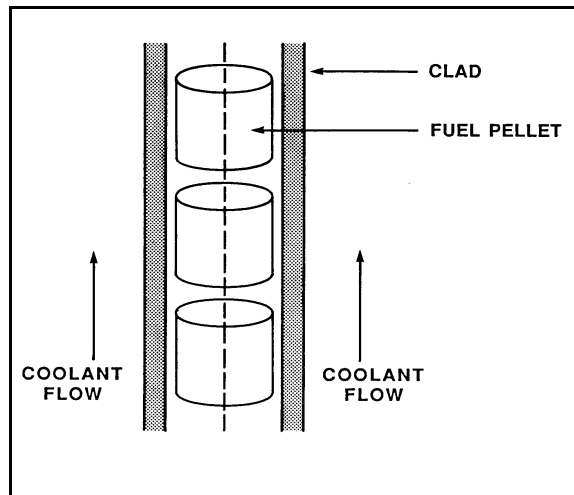

**USNRC GENERIC FUNDAMENTALS EXAMINATION
SEPTEMBER 2012 BWR--FORM A**

QUESTION: 47

A nuclear reactor is operating at steady-state 80 percent power near the beginning of a fuel cycle with core power distribution peaked radially in the center of the core and axially in the bottom half of the core. Only reactor recirculation flow rate adjustments will be used to maintain a constant reactor power over the next two months.

Neglecting any change in reactor poison distribution, during the next two months the maximum radial peaking factor will _____; and the maximum axial peaking factor will _____.

- A. increase; decrease
- B. increase; increase
- C. decrease; decrease
- D. decrease; increase

QUESTION: 48

Which one of the following is responsible for the clad failure that results from operating the reactor above the limit for linear heat generation rate?

- A. Fission product gas expansion causes clad internal design pressure to be exceeded.
- B. Corrosion buildup on the fuel clad surface reduces heat transfer and promotes transition boiling.
- C. The zircaloy-steam reaction causes accelerated oxidation of the clad at high temperatures.
- D. The difference between thermal expansion rates of the fuel pellets and the clad causes severe clad stress.

**USNRC GENERIC FUNDAMENTALS EXAMINATION
SEPTEMBER 2012 BWR--FORM A**

QUESTION: 49

With a nuclear reactor at 100 percent power, reactor pressure suddenly increases, causing a decrease in the latent heat of vaporization. Which one of the following is the limiting thermal limit for these conditions?

- A. Critical power ratio
- B. Linear heat generation rate
- C. Average planar linear heat generation rate
- D. Preconditioning interim operating management recommendations

QUESTION: 50

Which one of the following will apply a compressive stress to the outside wall of the reactor vessel?

- A. Neutron embrittlement of the reactor vessel.
- B. Increasing reactor coolant system (RCS) pressure.
- C. Performing an RCS cooldown.
- D. Performing an RCS heatup.

***** FINAL ANSWER KEY *****

**SEPTEMBER 2012 NRC GENERIC FUNDAMENTALS EXAMINATION
BOILING WATER REACTOR - ANSWER KEY**

<u>FORM A</u>	<u>FORM B</u>	<u>ANS.</u>	<u>FORM A</u>	<u>FORM B</u>	<u>ANS.</u>
1	15	B	26	40	C
2	16	B	27	41	D
3	17	C	28	42	D
4	18	B	29	43	C
5	19	B	30	44	C
6	20	C	31	45	A
7	21	Deleted	32	46	A
8	22	B	33	47	B
9	23	A	34	48	C
10	24	D	35	49	B
11	25	C	36	50	A
12	26	D	37	1	A
13	27	B	38	2	C
14	28	B	39	3	A
15	29	B	40	4	D
16	30	D	41	5	C
17	31	A	42	6	B
18	32	A	43	7	D
19	33	A	44	8	C
20	34	D	45	9	A
21	35	D	46	10	A
22	36	B	47	11	C
23	37	D	48	12	D
24	38	C	49	13	A
25	39	B	50	14	C