

**UNITED STATES NUCLEAR REGULATORY COMMISSION
BOILING WATER REACTOR GENERIC FUNDAMENTALS EXAMINATION
MARCH 2015 – FORM A**

Please Print

Name: _____

Docket No.: _____

Facility: _____

Start Time: _____ Stop Time: _____

INSTRUCTIONS TO APPLICANT

Answer all the test items using the answer sheet provided, ensuring a single answer is marked for each test item. Each test item has equal point value. A score of at least 80 percent is required to pass this portion of the NRC operator licensing written examination. All examination materials will be collected 3 hours after the examination begins. This examination applies to a typical U.S. boiling water reactor (BWR) nuclear power plant.

SECTION	QUESTIONS	% OF TOTAL	SCORE
COMPONENTS	1 - 22		
REACTOR THEORY	23 - 36		
THERMODYNAMICS	37 - 50		
TOTALS	50		

All work performed on this examination is my own. I have neither given nor received aid.

Applicant's Signature

RULES AND INSTRUCTIONS FOR THE NRC GENERIC FUNDAMENTALS EXAMINATION

During the administration of this examination the following rules apply:

NOTE: The term "control rod" refers to the length of neutron absorber material that can be positioned by the operator to change core reactivity.

NOTE: Numerical answers are rounded to the nearest whole number unless otherwise indicated.

1. Print your name in the blank provided on the cover sheet of the examination.
2. Fill in your individual docket number.
3. Fill in the name of your facility.
4. Fill in your start and stop times at the appropriate times.
5. Two aids are provided for your use during the examination:
 - (1) An Equations and Conversions Sheet contained within the examination copy, and
 - (2) Steam tables and Mollier Diagram provided by your proctor.
6. Place your answers on the answer sheet provided. Credit will only be given for answers properly marked on this sheet. Follow the instructions for filling out the answer sheet.
7. Scrap paper will be provided for calculations.
8. Cheating on the examination will result in the automatic forfeiture of this examination. Cheating could also result in severe penalties.
9. Restroom trips are limited. Only **one** examinee may leave the room at a time. In order to avoid the appearance or possibility of cheating, avoid all contact with anyone outside the examination room.
10. After you have completed the examination, sign the statement on the cover sheet indicating that the work is your own and you have neither given nor received any assistance in completing the examination. Either pencil or pen may be used.
11. Turn in your examination materials, answer sheet on top, followed by the examination copy and the examination aids, e.g., steam tables, handouts, and scrap paper.
12. After turning in your examination materials, leave the examination area as defined by the proctor. If after leaving you are found in the examination area while the examination is in progress, your examination may be forfeited.

GENERIC FUNDAMENTALS EXAMINATION
EQUATIONS AND CONVERSIONS SHEET

EQUATIONS

$$\dot{Q} = \dot{m}c_p\Delta T$$

$$A = A_0e^{-\lambda t}$$

$$\dot{Q} = \dot{m}\Delta h$$

$$N = S/(1 - K_{\text{eff}})$$

$$\dot{Q} = UA\Delta T$$

$$CR_1(1 - K_{\text{eff}_1}) = CR_2(1 - K_{\text{eff}_2})$$

$$\dot{Q} \propto \dot{m}_{\text{Nat Circ}}^3$$

$$1/M = CR_1/CR_x$$

$$\Delta T \propto \dot{m}_{\text{Nat Circ}}^2$$

$$A = \pi r^2$$

$$K_{\text{eff}} = 1/(1 - \rho)$$

$$F = PA$$

$$\rho = (K_{\text{eff}} - 1)/K_{\text{eff}}$$

$$\dot{m} = \rho A \bar{v}$$

$$\text{SUR} = 26.06/\tau$$

$$\dot{W}_{\text{Pump}} = \dot{m}\Delta P v$$

$$\tau = \frac{\bar{\beta}_{\text{eff}} - \rho}{\lambda_{\text{eff}} \rho}$$

$$P = IE$$

$$\rho = \frac{\ell^*}{\tau} + \frac{\bar{\beta}_{\text{eff}}}{1 + \lambda_{\text{eff}} \tau}$$

$$P_A = \sqrt{3}IE$$

$$P_T = \sqrt{3}IEpf$$

$$\ell^* = 1.0 \times 10^{-4} \text{ sec}$$

$$P_R = \sqrt{3}IE\sin\theta$$

$$\lambda_{\text{eff}} = 0.1 \text{ sec}^{-1} \text{ (for small positive } \rho)$$

$$\text{Thermal Efficiency} = \text{Net Work Out/Energy In}$$

$$\text{DRW} \propto \varphi_{\text{tip}}^2 / \varphi_{\text{avg}}^2$$

$$\frac{g(z_2 - z_1)}{g_c} + \frac{(\bar{v}_2^2 - \bar{v}_1^2)}{2g_c} + v(P_2 - P_1) + (u_2 - u_1) + (q - w) = 0$$

$$P = P_0e^{t/\tau}$$

$$g = 32.2 \text{ ft/sec}^2$$

$$P = P_010^{\text{SUR}(t)}$$

$$g_c = 32.2 \text{ lbf-ft/lbf-sec}^2$$

CONVERSIONS

$$1 \text{ MW} = 3.41 \times 10^6 \text{ Btu/hr}$$

$$^\circ\text{C} = (5/9)(^\circ\text{F} - 32)$$

$$1 \text{ ft}_{\text{water}}^3 = 7.48 \text{ gal}$$

$$1 \text{ hp} = 2.54 \times 10^3 \text{ Btu/hr}$$

$$^\circ\text{F} = (9/5)(^\circ\text{C}) + 32$$

$$1 \text{ gal}_{\text{water}} = 8.35 \text{ lbm}$$

$$1 \text{ Btu} = 778 \text{ ft-lbf}$$

$$1 \text{ kg} = 2.21 \text{ lbm}$$

$$1 \text{ Curie} = 3.7 \times 10^{10} \text{ dps}$$

**USNRC GENERIC FUNDAMENTALS EXAMINATION
MARCH 2015 BWR – FORM A**

QUESTION: 1

A completely full water storage tank is being hydrostatically tested to 200 psig using a positive displacement pump (PDP) with a smooth and constant discharge flow rate of 8 gpm. The tank is protected by a relief valve and a safety valve that both discharge to the atmosphere. The valves have the following characteristics:

- The relief valve opening setpoint is 220 psig with an accumulation of 5 percent.
- The safety valve opening setpoint is 260 psig with a blowdown of 5 percent.
- Both valves have a maximum discharge flow rate of 6 gpm.

The PDP is inadvertently left running when tank pressure reaches 200 psig.

After a few minutes with the PDP still running, the relief valve will be discharging a flow rate of approximately _____; and the safety valve will be _____.

- A. 2 gpm; partially open
- B. 6 gpm; partially open
- C. 2 gpm; cycling between fully open and fully closed
- D. 6 gpm; cycling between fully open and fully closed

**USNRC GENERIC FUNDAMENTALS EXAMINATION
MARCH 2015 BWR – FORM A**

QUESTION: 2

Refer to the drawing of a water supply pump with two suction sources (see figure below). All motor-operated valves (MOVs) are currently closed.

Which one of the following MOV interlocks will permit the pump to take a suction on either the building sump or the water storage tank, while preventing the two sources from being cross-connected?

- A. Neither MOV-1 nor MOV-2 can be opened unless MOV-3 is fully closed.
- B. None of the MOVs can be opened unless at least one MOV remains fully closed.
- C. None of the MOVs can be opened unless at least two MOVs remain fully closed.
- D. Neither MOV-1 nor MOV-2 can be opened unless the other source MOV is fully closed.

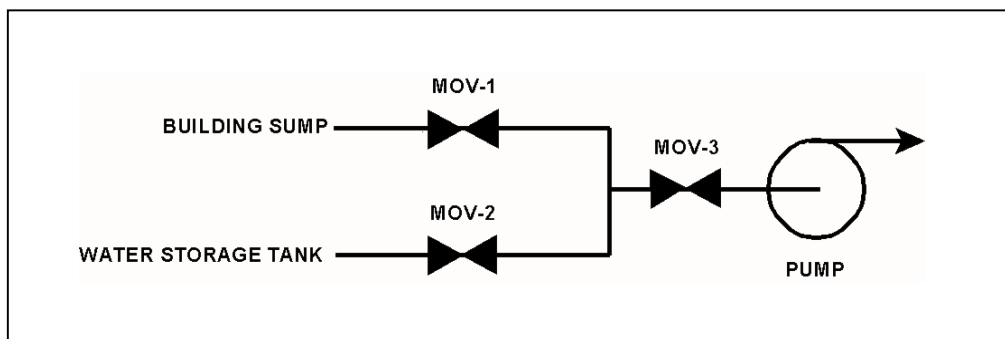

QUESTION: 3

Consider a 3-inch gate valve and a 3-inch globe valve in separate but identical operating water systems. If both valves are fully open, the gate valve will produce the _____ head loss and the _____ flow rate.

- A. smaller; larger
- B. larger; smaller
- C. smaller; smaller
- D. larger; larger

**USNRC GENERIC FUNDAMENTALS EXAMINATION
MARCH 2015 BWR – FORM A**

QUESTION: 4

Many reactor vessel water level instruments are designed with a condensing chamber in the reference leg. The purpose of the condensing chamber is to...

- A. provide a source of makeup water to the reference leg during normal operations.
- B. provide reference leg compensation for the reactor pressure exerted on the variable leg.
- C. prevent reference leg flashing during a rapid depressurization of the reactor vessel.
- D. ensure the reference leg temperature remains near the temperature of the water in the reactor vessel.

QUESTION: 5

A cooling water system pressure detector uses a bourdon tube as the sensing element. Which one of the following explains how the indicated system pressure will be affected if a local steam leak raises the temperature of the bourdon tube by 50°F? (Assume the cooling water system pressure does not change.)

- A. Indicated pressure will decrease because the bourdon tube will become more flexible.
- B. Indicated pressure will increase because the bourdon tube will become more flexible.
- C. Indicated pressure will decrease because the bourdon tube internal pressure will increase.
- D. Indicated pressure will increase because the bourdon tube internal pressure will increase.

**USNRC GENERIC FUNDAMENTALS EXAMINATION
MARCH 2015 BWR – FORM A**

QUESTION: 6

Refer to the drawing of a simple thermocouple circuit (see figure below) that is calibrated for a reference junction temperature of 90°F.

Thermocouple temperature indication is currently 150°F. Indicator range is from 0°F to 2000°F.

If one of the thermocouple extension wires loosens and becomes dislodged from its terminal in the reference junction panel, which one of the following temperature indications will result?

- A. 0°F
- B. 60°F
- C. 90°F
- D. 2000°F

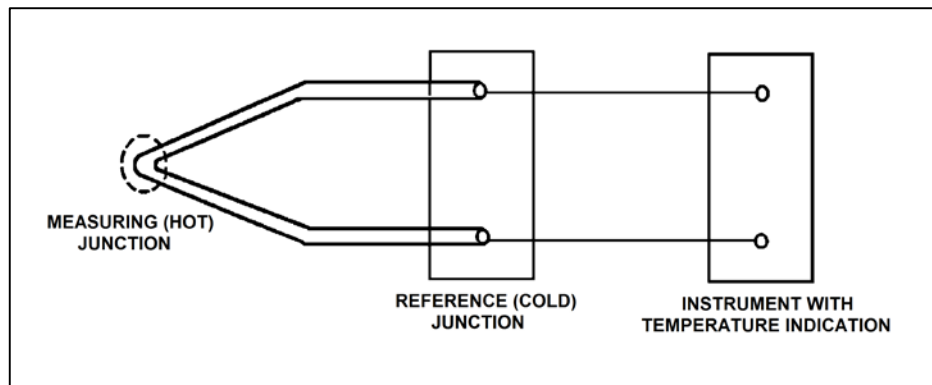

**USNRC GENERIC FUNDAMENTALS EXAMINATION
MARCH 2015 BWR – FORM A**

QUESTION: 7

A proportional detector with pulse height discrimination circuitry is being used in a constant field of neutron and gamma radiation to provide source range neutron count rate indication. Assume the pulse height discrimination value does not change.

If the detector voltage is increased significantly, but maintained within the proportional region, the detector count rate indication will _____; and the detector will become _____ susceptible to the positive space charge effect.

- A. increase; less
- B. increase; more
- C. remain the same; less
- D. remain the same: more

QUESTION: 8

Which one of the following is a characteristic that applies to a proportional-only controller, but not to a proportional-integral controller?

- A. Gain
- B. Offset
- C. Rate component
- D. Bistable component

**USNRC GENERIC FUNDAMENTALS EXAMINATION
MARCH 2015 BWR – FORM A**

QUESTION: 9

What is the purpose of a valve positioner in a typical pneumatic valve control system?

- A. Convert the valve controller pneumatic output signal into a mechanical force to position the valve.
- B. Convert the valve controller pneumatic output signal into an electrical output to position the valve.
- C. Compare valve controller pneumatic output signal to setpoint error, and adjust valve actuator air supply pressure to position the valve.
- D. Compare valve controller pneumatic output signal to valve position, and adjust valve actuator air supply pressure to position the valve.

QUESTION: 10

Which one of the following describes gas binding of a centrifugal pump?

- A. Pump capacity is reduced, due to the presence of steam or air in the pump impeller.
- B. Pump capacity is reduced, due to windage losses between the pump impeller and pump casing.
- C. Pump motor current increases, due to the compression of gases in the pump volute.
- D. Pump motor current increases, due to the high head requirements for pumping a fluid saturated with dissolved gases.

**USNRC GENERIC FUNDAMENTALS EXAMINATION
MARCH 2015 BWR – FORM A**

QUESTION: 11

Refer to the drawing of an operating cooling water system (see figure below).

How will the centrifugal pump flow rate be affected if the surge tank level decreases from 8 feet to 4 feet? (Assume the pump maintains adequate net positive suction head.)

- A. Pump flow rate will increase.
- B. Pump flow rate will decrease.
- C. Pump flow rate will remain the same.
- D. Cannot be determined without additional information.

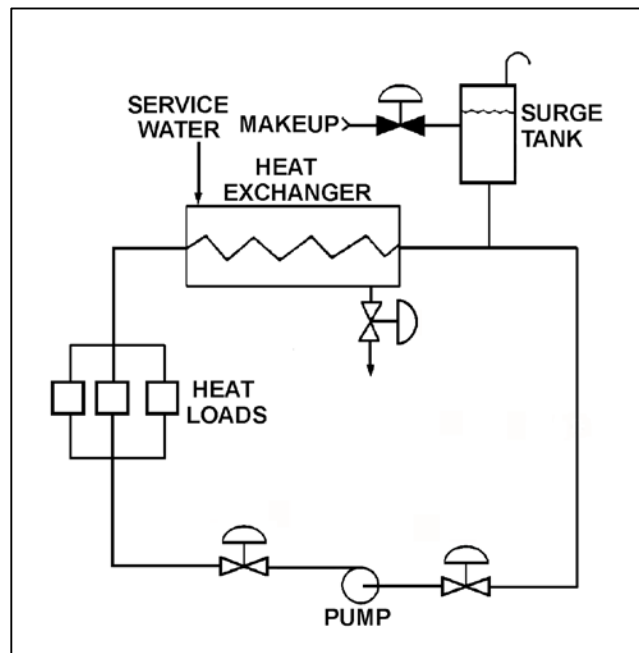

**USNRC GENERIC FUNDAMENTALS EXAMINATION
MARCH 2015 BWR – FORM A**

QUESTION: 12

Refer to the drawing of an operating curve for a positive displacement pump in a closed water system (see figure below).

Which one of the following describes the value of the head where the two curves cross?

- A. The maximum amount of head that the pump can provide.
- B. The amount of pump head that is required to avoid cavitation.
- C. The amount of pump head that is converted to kinetic energy in the pump.
- D. The amount of pump head that is converted to heat as the water circulates through the system.

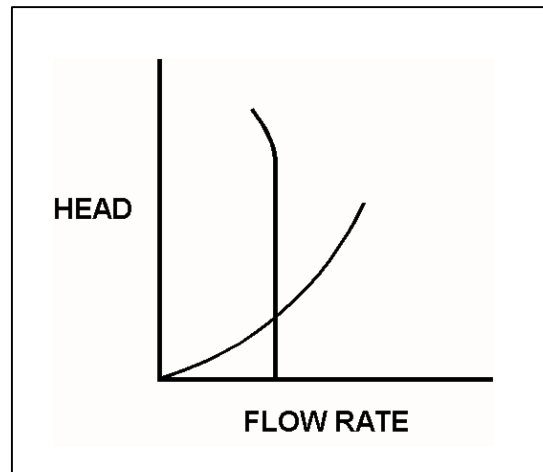

**USNRC GENERIC FUNDAMENTALS EXAMINATION
MARCH 2015 BWR – FORM A**

QUESTION: 13

Water enters a positive displacement pump at 50 psig and 90°F. What is the available net positive suction head for the pump?

- A. 80 feet
- B. 114 feet
- C. 133 feet
- D. 148 feet

QUESTION: 14

When a motor-driven centrifugal pump was started, the motor ammeter reading immediately increased to, and stabilized at, many times the normal operating value. Which one of the following describes a possible cause for the ammeter response?

- A. The pump was started with a fully closed discharge valve.
- B. The pump was started with a fully open discharge valve.
- C. The pump shaft seized upon start and did not rotate.
- D. The pump shaft separated from the motor shaft upon start.

**USNRC GENERIC FUNDAMENTALS EXAMINATION
MARCH 2015 BWR – FORM A**

QUESTION: 15

A main generator is connected to an infinite power grid with the following generator output parameters:

22 KV
60 Hertz
600 MW
100 MVAR (in)

Which one of the following contains a combination of manual adjustments to the main generator voltage regulator and speed control setpoints such that each adjustment will result in main generator operation at a power factor closer to 1.0? (Assume the generator power factor remains less than 1.0.)

- | | <u>Voltage
Setpoint</u> | <u>Speed
Setpoint</u> |
|----|-----------------------------|---------------------------|
| A. | Increase | Increase |
| B. | Increase | Decrease |
| C. | Decrease | Increase |
| D. | Decrease | Decrease |

**USNRC GENERIC FUNDAMENTALS EXAMINATION
MARCH 2015 BWR – FORM A**

QUESTION: 16

Which one of the following will increase the heat transfer rate between two liquids in a heat exchanger? (Assume single-phase conditions and a constant specific heat for both liquids.)

- A. The mass flow rate of the hotter liquid decreases by 10 percent.
- B. The mass flow rate of the colder liquid decreases by 10 percent.
- C. The inlet temperature of the hotter liquid increases by 20°F.
- D. The inlet temperature of the colder liquid increases by 20°F.

QUESTION: 17

A nuclear power plant is operating at steady-state 100 percent power when air inleakage causes main condenser vacuum to decrease from 28 inches Hg vacuum to 27 inches Hg vacuum. Assume the main steam inlet pressure, inlet quality, and mass flow rate through the main turbine do not change, and the condenser cooling water inlet temperature and mass flow rate do not change.

When the plant stabilizes, turbine exhaust quality will be _____; and turbine exhaust temperature will be _____.

- A. higher; higher
- B. higher; lower
- C. lower; higher
- D. lower; lower

**USNRC GENERIC FUNDAMENTALS EXAMINATION
MARCH 2015 BWR – FORM A**

QUESTION: 18

A pressure gauge on a condenser reads 27 inches of mercury (Hg) vacuum. What is the absolute pressure corresponding to this vacuum?

- A. 1.0 psia
- B. 1.5 psia
- C. 13.5 psia
- D. 14.0 psia

QUESTION: 19

The decontamination factor of a condensate demineralizer has just been determined to be 50, based on conductivity measurements.

If condensate having a conductivity of 20 $\mu\text{mho/cm}$ is flowing into this demineralizer, which one of the following is the conductivity of the condensate at the outlet of the demineralizer?

- A. 0.4 $\mu\text{mho/cm}$
- B. 1.0 $\mu\text{mho/cm}$
- C. 4.0 $\mu\text{mho/cm}$
- D. 10.0 $\mu\text{mho/cm}$

**USNRC GENERIC FUNDAMENTALS EXAMINATION
MARCH 2015 BWR – FORM A**

QUESTION: 20

A lower than expected differential pressure across a mixed-bed demineralizer is an indication of...

- A. depletion of the resin.
- B. channeling through the resin bed.
- C. improper resin regeneration.
- D. a decrease in inlet conductivity.

QUESTION: 21

Which one of the following describes the operation of a thermal overload device for a large motor?

- A. A temperature sensor monitors the temperature of the operating equipment and completes a circuit to trip the breaker if the temperature setpoint is exceeded.
- B. A balanced bridge circuit compares actual current to a fixed overcurrent setpoint and completes a circuit to trip the breaker if the current setpoint is exceeded.
- C. A heater element in series with the motor heats up in proportion to the motor current and completes a circuit to trip the breaker if a high current condition persists.
- D. An induction coil in series with the motor generates a secondary current proportional to the primary current and completes a circuit to trip the breaker if a high current condition persists.

**USNRC GENERIC FUNDAMENTALS EXAMINATION
MARCH 2015 BWR – FORM A**

QUESTION: 22

Which one of the following results from a loss of control power to a breaker supplying a motor?

- A. Motor ammeter indication will be zero regardless of actual breaker position.
- B. Breaker position will remotely indicate closed regardless of actual position.
- C. Breaker will trip open due to the actuation of its protective trip device.
- D. Charging motor will not charge the closing spring after the breaker is locally closed.

QUESTION: 23

Which one of the following is the process that produces the majority of prompt neutrons in an operating nuclear plant reactor?

- A. A thermal neutron is absorbed by a fuel nucleus. Almost immediately, the nucleus fissions and emits one or more prompt neutrons.
- B. A thermal neutron is absorbed by a fuel nucleus. Almost immediately, the fuel nucleus fissions and produces fission products. During the decay of the fission products, one or more prompt neutrons are emitted.
- C. A fast neutron is absorbed by a fuel nucleus. Almost immediately, the nucleus fissions and emits one or more prompt neutrons.
- D. A fast neutron is absorbed by a fuel nucleus. Almost immediately, the fuel nucleus fissions and produces fission products. During the decay of the fission products, one or more prompt neutrons are emitted.

**USNRC GENERIC FUNDAMENTALS EXAMINATION
MARCH 2015 BWR – FORM A**

QUESTION: 24

The shutdown margin for an operating reactor is the amount of reactivity by which a xenon-free reactor at 68°F would be subcritical if all control rods were...

- A. inserted, except for an average worth control rod which remains fully withdrawn.
- B. withdrawn, except for an average worth control rod which remains fully inserted.
- C. inserted, except for the highest worth control rod which remains fully withdrawn.
- D. withdrawn, except for the highest worth control rod which remains fully inserted.

QUESTION: 25

Two reactors are identical except that reactor A is near the end of a fuel cycle and reactor B is near the beginning of a fuel cycle. Both reactors are critical at 1.0×10^{-5} percent power.

If the same amount of positive reactivity is added to each reactor at the same time, the point of adding heat will be reached first by reactor _____ because it has a _____ effective delayed neutron fraction.

- A. A; smaller
- B. A; larger
- C. B; smaller
- D. B; larger

**USNRC GENERIC FUNDAMENTALS EXAMINATION
MARCH 2015 BWR – FORM A**

QUESTION: 26

A reactor has an initial effective fuel temperature of 800EF. If the effective fuel temperature increases to 1,000EF, the fuel temperature coefficient will become _____ negative; because at higher effective fuel temperatures, a 1EF increase in effective fuel temperature produces a _____ change in Doppler broadening.

- A. less; greater
- B. less; smaller
- C. more; greater
- D. more; smaller

QUESTION: 27

During a reactor power decrease from steady-state 100 percent to steady-state 20 percent, the smallest addition of positive reactivity will be caused by the change in...

- A. void percentage.
- B. fuel temperature.
- C. xenon concentration.
- D. moderator temperature.

**USNRC GENERIC FUNDAMENTALS EXAMINATION
MARCH 2015 BWR – FORM A**

QUESTION: 28

If the void fraction surrounding several centrally located fuel bundles increases, the worth of the associated control rods will...

- A. decrease, because the average neutron energy in the fuel bundles decreases, resulting in fewer neutrons traveling from within the fuel bundles to the affected control rods.
- B. decrease, because more neutrons are resonantly absorbed in the fuel while they are being thermalized, resulting in fewer thermal neutrons available to be absorbed by the affected control rods.
- C. increase, because the diffusion length of the thermal neutrons increases, resulting in more thermal neutrons traveling from within the fuel bundles to the affected control rods.
- D. increase, because neutrons will experience a longer slowing down length, resulting in a smaller fraction of thermal neutrons being absorbed by the fuel and more thermal neutrons available to be absorbed by the affected control rods.

QUESTION: 29

Neutron flux shaping within a reactor core is designed to...

- A. prevent the effects of rod shadowing during control rod motion.
- B. generate more power in the top portion of the core early in core life.
- C. ensure that local core thermal power limits are not exceeded.
- D. minimize the reverse power effect during control rod motion.

**USNRC GENERIC FUNDAMENTALS EXAMINATION
MARCH 2015 BWR – FORM A**

QUESTION: 30

A reactor had been operating at 100 percent power for 2 months when a reactor scram occurred. Four hours later with a startup in progress, reactor power is currently stable at 10 percent. Which one of the following operator actions is required to maintain reactor power at 10 percent over the next 18 hours?

- A. Incremental control rod withdrawals throughout the entire period.
- B. Incremental control rod insertions throughout the entire period.
- C. Incremental control rod withdrawals for several hours, then incremental insertions for the rest of the period.
- D. Incremental control rod insertions for several hours, then incremental withdrawals for the rest of the period.

QUESTION: 31

A reactor was operating at 100 percent power with equilibrium xenon-135 at the beginning of a fuel cycle when a reactor scram occurred. If the reactor is taken critical 4 hours later, which one of the following describes the effect of xenon-135 on control rod worth when the reactor becomes critical?

- A. Increasing xenon-135 concentration at the periphery of the core is causing periphery control rods to exhibit increasing worth.
- B. Increasing thermal neutron flux at the periphery of the core is causing periphery control rods to exhibit increasing worth.
- C. Increasing thermal neutron flux at the center of the core is causing center control rods to exhibit increasing worth.
- D. Decreasing xenon-135 concentration at the center of the core is causing center control rods to exhibit increasing worth.

**USNRC GENERIC FUNDAMENTALS EXAMINATION
MARCH 2015 BWR – FORM A**

QUESTION: 32

Refer to the drawing of K_{eff} versus core age (see figure below).

The major cause for the change in K_{eff} from point 2 to point 3 is the...

- A. depletion of fuel.
- B. depletion of control rods.
- C. burnout of burnable poisons.
- D. burnout of fission product poisons.

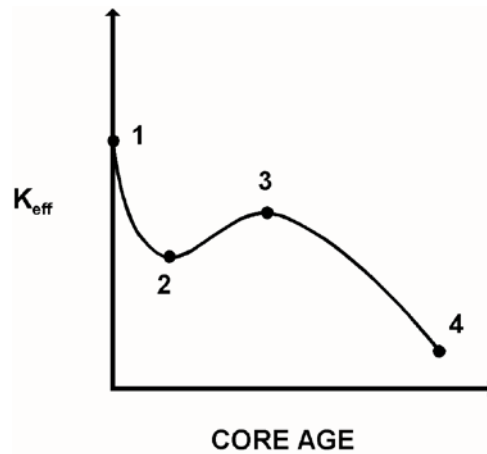

**USNRC GENERIC FUNDAMENTALS EXAMINATION
MARCH 2015 BWR – FORM A**

QUESTION: 33

A refueling outage has just been completed, and a reactor startup is being commenced. Which one of the following lists the method(s) typically used to add positive reactivity during the approach to criticality?

- A. Control rods only
- B. Recirculation flow only
- C. Control rods and recirculation flow
- D. Recirculation flow and steaming rate

**USNRC GENERIC FUNDAMENTALS EXAMINATION
MARCH 2015 BWR – FORM A**

QUESTION: 34

Refer to the drawing of a $1/M$ plot with curves A and B (see figure below). Each axis has linear units.

Curve A would result if each fuel assembly loaded during the early stages of the refueling caused a relatively _____ fractional change in source range count rate compared to the later stages of the refueling; curve B would result if each fuel assembly contained equal _____.

- A. small; fuel enrichment
- B. small; reactivity
- C. large; fuel enrichment
- D. large; reactivity

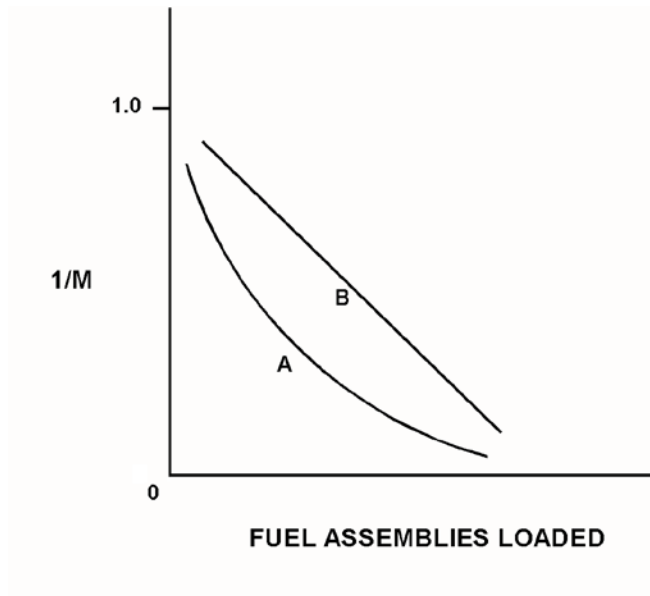

**USNRC GENERIC FUNDAMENTALS EXAMINATION
MARCH 2015 BWR – FORM A**

QUESTION: 35

A reactor has just achieved criticality during a xenon-free reactor startup. Instead of stabilizing source range count rate at 1.0×10^3 cps per the startup procedure, the operator inadvertently allows count rate to increase to 1.0×10^4 cps.

Assuming reactor vessel coolant temperature and pressure do not change, the critical rod height at 1.0×10^4 cps will be _____ the critical rod height at 1.0×10^3 cps. (Neglect any effects of changes in fission product poisons.)

- A. different, but unpredictable compared to
- B. less than
- C. greater than
- D. equal to

QUESTION: 36

A reactor startup is in progress with the reactor at normal operating temperature and pressure. With reactor power stable at the point of adding heat, a control rod malfunction causes a short rod withdrawal that increases reactivity by $0.14\% \Delta K/K$.

Given:

- All control rod motion has stopped.
- No automatic system or operator actions occur to inhibit the power increase.
- Power coefficient equals $-0.028\% \Delta K/K/\text{percent}$.
- The effective delayed neutron fraction equals 0.006.

What is the approximate power level increase required to offset the reactivity added by the control rod withdrawal? (Ignore any reactivity effects from changes in fission product poisons.)

- A. 2.0 percent
- B. 5.0 percent
- C. 20 percent
- D. 50 percent

**USNRC GENERIC FUNDAMENTALS EXAMINATION
MARCH 2015 BWR – FORM A**

QUESTION: 37

Refer to the drawing of a water-filled manometer (see figure below).

The manometer is installed across an orifice in a ventilation duct to determine the direction of airflow. With the manometer conditions as shown, the pressure at P1 is _____ than P2; and the direction of airflow is _____.

- A. less; right to left
- B. less; left to right
- C. greater; right to left
- D. greater; left to right

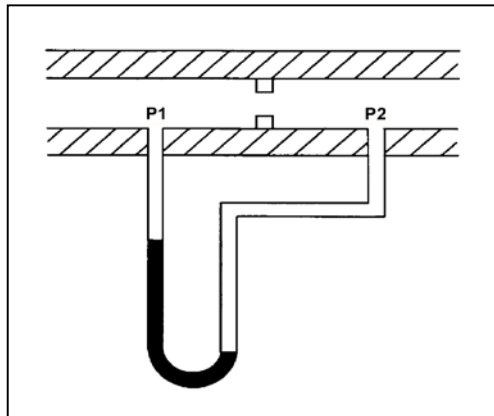

**USNRC GENERIC FUNDAMENTALS EXAMINATION
MARCH 2015 BWR – FORM A**

QUESTION: 38

Dry saturated steam enters a turbine at 1000 psia with the turbine exhaust pressure at 2 psia. The efficiency of the turbine is 85 percent. What is the approximate specific work output of the turbine?

- A. 329 Btu/lbm
- B. 355 Btu/lbm
- C. 387 Btu/lbm
- D. 455 Btu/lbm

QUESTION: 39

Steam entering an air ejector reaches sonic velocity in the throat of a convergent-divergent nozzle. Upon entering the divergent section of the nozzle, steam velocity will _____ and steam pressure will _____.

- A. decrease; decrease
- B. decrease; increase
- C. increase; decrease
- D. increase; increase

**USNRC GENERIC FUNDAMENTALS EXAMINATION
MARCH 2015 BWR – FORM A**

QUESTION: 40

A nuclear power plant is operating at 80 percent power with 10°F of condensate subcooling. Which one of the following initially will increase the steam cycle thermal efficiency? (Assume main condenser vacuum does not change unless stated otherwise.)

- A. Isolating extraction steam to a feedwater heater.
- B. Decreasing main condenser cooling water flow rate.
- C. Decreasing main condenser cooling water inlet temperature.
- D. Decreasing main condenser vacuum (increasing pressure).

QUESTION: 41

Which one of the following will result in a higher probability and/or severity of water hammer in a flowing water system?

- A. Gradual pipe bends rather than sharp pipe bends.
- B. Shorter pipe lengths rather than longer pipe lengths.
- C. Lower initial flow rates rather than higher initial flow rates.
- D. Shorter valve stroke times rather than longer valve stroke times.

**USNRC GENERIC FUNDAMENTALS EXAMINATION
MARCH 2015 BWR – FORM A**

QUESTION: 42

A centrifugal pump is operating at a constant speed in a closed system with the following initial parameters:

Suction pressure = 10 psig
Discharge pressure = 25 psig
Pump flow rate = 500 gpm

If the pump discharge flow control valve is throttled such that the pump discharge pressure increases to 40 psig, the change in pump flow rate will be...

- A. directly proportional to the square of the change in pump differential pressure.
- B. directly proportional to the square root of the change in pump differential pressure.
- C. inversely proportional to the square root of the change in pump differential pressure.
- D. impossible to determine from the provided information.

QUESTION: 43

The power range nuclear instruments have been adjusted to 100 percent based on a heat balance calculation. Which one of the following will result in indicated reactor power being lower than actual reactor power?

- A. The feedwater temperature used in the heat balance calculation was 20°F higher than actual feedwater temperature.
- B. The reactor recirculation pump heat input term was omitted from the heat balance calculation.
- C. The feedwater flow rate used in the heat balance calculation was 10 percent higher than actual feedwater flow rate.
- D. The steam pressure used in the heat balance calculation was 50 psi lower than actual steam pressure.

**USNRC GENERIC FUNDAMENTALS EXAMINATION
MARCH 2015 BWR – FORM A**

QUESTION: 44

Refer to the drawing of a pool boiling curve (see figure below).

Which region of the curve contains the operating point at which the hottest locations of a reactor normally operate to transfer heat from the fuel cladding to the coolant at 100 percent power?

- A. Region I
- B. Region II
- C. Region III
- D. Region IV

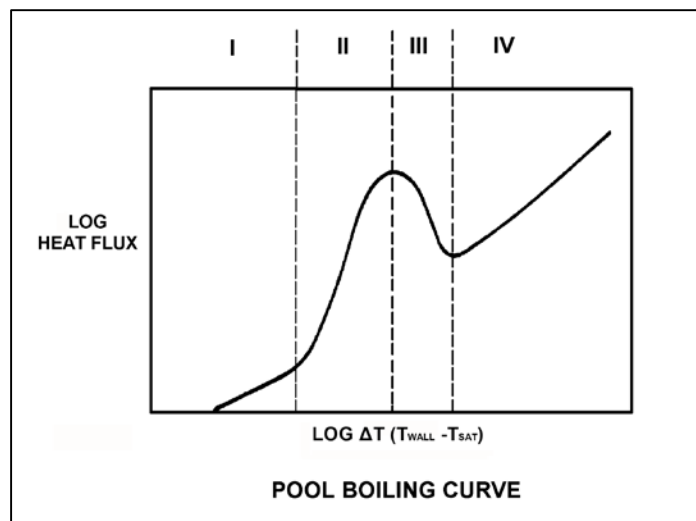

**USNRC GENERIC FUNDAMENTALS EXAMINATION
MARCH 2015 BWR – FORM A**

QUESTION: 45

Refer to the drawing of a section of pipe that contains flowing subcooled water (see figure below).

Given:

- The pressure at P_1 is 20 psig.
- The pressure at P_2 is 20 psig.
- The pressure change caused by the change in velocity is 2 psig.
- The pressure change caused by the change in elevation is 8 psig.

The pressure decrease due to friction head loss between P_1 and P_2 is _____; and the direction of flow is from _____.

- A. 6 psig; left to right
- B. 6 psig; right to left
- C. 10 psig; left to right
- D. 10 psig; right to left

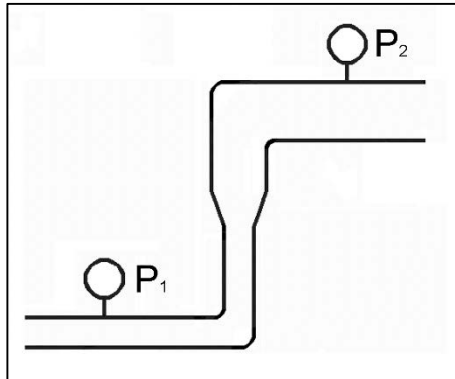

**USNRC GENERIC FUNDAMENTALS EXAMINATION
MARCH 2015 BWR – FORM A**

QUESTION: 46

Which one of the following occurs as a result of reactor core orifices?

- A. The core differential pressure is minimized at all power levels.
- B. The total core coolant flow rate remains the same at all power levels.
- C. The total core coolant flow rate is divided equally through all bundles at all power levels.
- D. The highest bundle coolant flow rates exist in core interior bundles at all power levels.

QUESTION: 47

In a reactor operating at full power, the fuel bundle with the lowest power always has the smallest...

- A. critical power ratio.
- B. radial peaking factor.
- C. axial peaking factor.
- D. critical heat flux.

**USNRC GENERIC FUNDAMENTALS EXAMINATION
MARCH 2015 BWR – FORM A**

QUESTION: 48

If the linear heat generation rate (LHGR) limiting condition for operation is exceeded, the most probable type of fuel cladding failure is...

- A. cracking, due to high stress.
- B. gross failure, due to a lack of cooling.
- C. embrittlement, due to excessive oxidation.
- D. distortion, due to inadequate cooling.

QUESTION: 49

A nuclear power plant is operating at 90 percent power near the end of a fuel cycle when a signal error causes the turbine control system to throttle the turbine control valves 5 percent in the closed direction. Assuming the turbine control valves stabilize in their new position and the reactor does not scram, the critical power ratio will initially...

- A. increase, because reactor power initially increases.
- B. decrease, because reactor power initially decreases.
- C. increase, because the reactor coolant latent heat of vaporization initially increases.
- D. decrease, because the reactor coolant latent heat of vaporization initially decreases.

**USNRC GENERIC FUNDAMENTALS EXAMINATION
MARCH 2015 BWR – FORM A**

QUESTION: 50

Which one of the following will apply a compressive stress to the outside wall of the reactor vessel?

- A. Neutron embrittlement of the reactor vessel.
- B. Increasing reactor pressure.
- C. Performing a reactor cooldown.
- D. Performing a reactor heatup.

***** FINAL ANSWER KEY *****

**MARCH 2015 NRC GENERIC FUNDAMENTALS EXAMINATION
BOILING WATER REACTOR - ANSWER KEY**

<u>FORM A</u>	<u>FORM B</u>	<u>ANS.</u>	<u>FORM A</u>	<u>FORM B</u>	<u>ANS.</u>
1	15	D	26	40	B
2	16	D	27	41	D
3	17	A	28	42	B
4	18	A	29	43	C
5	19	B	30	44	C
6	20	C	31	45	B
7	21	B	32	46	C
8	22	B	33	47	A
9	23	D	34	48	D
10	24	A	35	49	D
11	25	C	36	50	B
12	26	D	37	1	A
13	27	D	38	2	A
14	28	C	39	3	C
15	29	A	40	4	B
16	30	C	41	5	D
17	31	A	42	6	D
18	32	B	43	7	A
19	33	A	44	8	B
20	34	B	45	9	B
21	35	C	46	10	D
22	36	D	47	11	B
23	37	A	48	12	A
24	38	C	49	13	D
25	39	A	50	14	C