

Marty L. Richey
Site Vice President

724-682-5234
Fax: 724-643-8069

June 3, 2016

L-16-062

10 CFR 50.55a

ATTN: Document Control Desk
U. S. Nuclear Regulatory Commission
Washington, DC 20555-0001

SUBJECT:

Beaver Valley Power Station, Unit No. 2

Docket No. 50-412, License No. NPF-73

10 CFR 50.55a Request for Alternative to ASME Class 1 and Class 2 Requirements for Components Connected to the Steam Side of the Pressurizer (Request BV2-PZR-01)

In accordance with 10 CFR 50.55a(z)(2), FirstEnergy Nuclear Operating Company (FENOC) hereby requests Nuclear Regulatory Commission (NRC) approval of a proposed alternative to certain American Society of Mechanical Engineers (ASME) Boiler and Pressure Vessel Code, Section III requirements.

The proposed alternative would allow certain piping, tubing, and valves to remain as designed and constructed in lieu of upgrading the design and replacing these components with those constructed to ASME Code Class 1 and 2 requirements. Replacement of the components would be a hardship without a compensating increase in quality and safety. The enclosure identifies the affected components, the applicable code requirements, and the description and basis of the proposed alternative.

FENOC requests approval of the proposed alternative by May 31, 2017.

There are no regulatory commitments contained in this submittal. If there are any questions or if additional information is required, please contact Mr. Thomas A. Lentz, Manager – Fleet Licensing, at (330) 315-6810.

Sincerely,

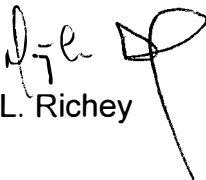

Marty L. Richey

Beaver Valley Power Station, Unit No. 2
L-16-062
Page 2

Enclosure:

Beaver Valley Power Station, Unit No. 2, 10 CFR 50.55a Request BV2-PZR-01, Revision 0

cc: NRC Region I Administrator
NRC Resident Inspector
NRC Project Manager
Director BRP/DEP
Site BRP/DEP Representative

Enclosure
L-16-062

Beaver Valley Power Station, Unit No. 2,
10 CFR 50.55a Request BV2-PZR-01, Revision 0

(7 Pages Follow)

Proposed Alternative
 In Accordance with 10 CFR 50.55a(z)(2)

--Hardship Without a Compensating Increase in Quality and Safety--

1. ASME CODE COMPONENTS AFFECTED

The affected components are American Society of Mechanical Engineers (ASME) Boiler and Pressure Vessel Code (ASME Code), Section III, Class 2 (hereafter referred to as Class 2) portions of the reactor coolant system (RCS), including piping, tubing, and valves connected to the pressurizer above the normal water level. American National Standards Institute (ANSI) B31.1 non-nuclear safety (NNS) piping is also included.

The affected piping, tubing, and valves are shown in the attachment to this relief request (reactor coolant piping flow diagram, RM-0075B) and are described and listed below:

- Upper pressurizer instrument lines including piping, tubing, and valves beginning at pressurizer line numbers 2-RCS-750-94-2, 2-RCS-750-97-2, and 2-RCS-750-99-2, and ending at the pressure transmitters.
- The pressurizer safety valve loop seal drain lines 2-RCS-001-228-2, 2-RCS-001-212-2, and 2-RCS-001-211-2, including the NNS portions.

Functional Location	Type	Location on Drawing RM-0075B	Description
2-RCS-001-228-2	Piping	C-2	1 inch nominal pipe size (NPS) Class 2 pressurizer relief valve A loop seal drain line
2RCS-60	Valve	C-2	1 inch NPS Class 2 pressurizer relief valve A loop seal drain line isolation valve
2-RCS-001-263-4	Piping	C-2	1 inch NPS NNS pressurizer relief valve A loop seal drain line
2-RCS-001-212-2	Piping	D-2	1 inch NPS Class 2 pressurizer relief valve B loop seal drain line
2RCS-61	Valve	D-2	1 inch NPS Class 2 pressurizer relief valve B loop seal drain line isolation valve
2-RCS-001-240-4	Piping	D-2	1 inch NPS NNS pressurizer relief valve B loop seal drain line
2-RCS-001-211-2	Piping	F-2	1 inch NPS Class 2 pressurizer relief valve C loop seal drain line
2RCS-62	Valve	F-2	1 inch NPS Class 2 pressurizer relief valve C loop seal drain line isolation valve
2-RCS-001-241-4	Piping	F-2	1 inch NPS NNS pressurizer relief valve C loop seal drain line

Functional Location	Type	Location on Drawing RM-0075B	Description
2-RCS-750-94-2	Piping	D-3	3/4 inch NPS Class 2 vapor space instrumentation connection
2RCS-271	Valve	C-3	3/4 inch NPS Class 2 instrumentation isolation valve
Instrument tubing and valves after 2RCS-271*	Tubing and valves	C-3	1/2 inch and smaller Class 2 instrumentation tubing and valves between valve 2RCS-271 and level transmitters 2RCS-LT461 and 2RCS-LT462
2-RCS-750-97-2	Piping	D-3	3/4 inch NPS Class 2 vapor space instrumentation connection
2RCS-265	Valve	F-3	3/4 inch NPS Class 2 Instrumentation isolation valve
Instrument tubing and valves after 2RCS-265*	Tubing and valves	F-3	1/2 inch and smaller Class 2 instrumentation tubing and valves between valve 2RCS-265 and level transmitters 2RCS-LT459 and 2RCS-LT459AF
2-RCS-750-99-2	Piping	D-3	3/4 inch NPS Class 2 vapor space instrumentation connection
2RCS-268	Valve	E-3	3/4 inch NPS Class 2 instrumentation isolation valve
Instrument tubing and valves after 2RCS-268*	Tubing and valves	E-3	1/2 inch and smaller Class 2 instrumentation tubing and valves between valve 2RCS-268 and level transmitter 2RCS-LT460

* Instrumentation tubing and valves are not assigned a functional location.

Piping and tubing supports were constructed as safety-related in accordance with the rules of ANSI B31.1, Paragraph 121.1, and are therefore not a part of this request.

2. APPLICABLE CODE EDITION AND ADDENDA

The code of record for the Class 2 components is ASME Code, Section III, 1971 Edition with addenda through Winter of 1972. The code of record for the NNS components is ANSI B31.1, 1967 Edition, with addenda through June 30, 1972.

3. APPLICABLE CODE REQUIREMENTS

Paragraph 50.55a(c) of Title 10 of the *Code of Federal Regulations* (10 CFR) states, in part:

- (1) Standards requirement for reactor coolant pressure boundary components. Components that are part of the reactor coolant pressure boundary must meet the requirements for Class 1 components in Section III^{1, 4} of the ASME BPV Code, except as provided in paragraphs (c)(2) through (4) of this section.

4. REASON FOR REQUEST

Westinghouse Electric Company Nuclear Safety Advisory Letter (NSAL), NSAL-00-006, "Pressurizer Upper Level Instrument Line Safety Classification," was issued April 3, 2000. The letter identified an issue where a break in an instrument line connected to the upper portion (steam side) of the pressurizer may result in a depressurization of the RCS sufficient to cause a reactor trip and emergency core cooling system (ECCS) actuation based on low pressurizer pressure. For an instrument line connected to the pressurizer, in which a break in the line may result in ECCS actuation, the line should be classified as ASME Class 1 in accordance with ANSI N18.2-1973.

Westinghouse Electric Company NSAL-07-9, Revision 1, "Safety Classification of Small Lines Connected to the Pressurizer Steam Space," issued on August 11, 2008, further expanded the scope of NSAL-00-006 to include not only instrument lines, but other small lines connected to the pressurizer steam space. These small lines include pressurizer safety valve loop seal drain lines, the pressurizer steam sample vent line, and the pressurizer spray bypass line.

Based on ANSI 51.1, "Nuclear Safety Criteria for the Design of Stationary Pressurized Water Reactor Plants," 1983 Edition, Figure 3.1, the Class 2 to NNS class break at the pressurizer safety valve loop drains is no longer valid. Had the Class 2 piping and valves been properly classified as Class 1, an acceptable Class 1 to Class 2 break would be allowed at the normally closed isolation valves. Therefore, the NNS piping would have been required to be Class 2.

The affected piping, tubing, and valves described in Part 1 of this request were designed and constructed in accordance with the rules of ASME Section III, Subsection NC for the Class 2 components, and ANSI B31.1 for the NNS components. A break in these small lines is bounded by a postulated small break loss-of-coolant accident and would not represent a substantial safety hazard or unanalyzed condition were it to occur. As demonstrated in the discussion of technical requirement differences in Part 5 of this request, replacing the affected components to comply with ASME Section III Class 1 or Class 2 requirements would be a hardship without a compensating increase in quality and safety and would require significant personnel radiation exposure due to component proximity to the pressurizer.

5. PROPOSED ALTERNATIVE AND BASIS FOR USE

The proposed alternative is to allow the piping, tubing, and valves identified in Part 1 of this request to remain as designed and constructed to ASME Class 2 and ANSI B31.1 NNS in lieu of upgrading the current design configuration and replacing these components with components constructed to ASME Section III Class 1 (hereafter referred to as Class 1) and Class 2 requirements. The basis for use of this proposed alternative is presented in the following paragraphs.

To justify the proposed alternative, a comparison was made between the Section III requirements in Subsection NB for Class 1 and Subsection NC for Class 2 for the applicable editions and addenda described in Part 2 of this request. A comparison was made between the ANSI B31.1 code and ASME Section III, Subsection NC for the NNS pipe. The comparison looked at each article of Subsections NB, NC, and ANSI B31.1 (covering the areas of materials, design, fabrication and installation, examination, testing, protection against overpressure, and nameplates, stamping and reports), and determined whether the differences were administrative, quality, or technical requirements. Differences in Section III administrative

requirements, such as certification and stamping, furnishing of a stress report, marking of components, and so on, although affecting literal compliance, were determined to not reduce the quality or safety of the components.

There were few differences in quality requirements between Class 1 and Class 2 because most quality requirements are contained in the general requirements Subsection NA and are equally applicable to both Class 1 and Class 2. However, no differences in quality requirements were identified that would reduce the quality or safety of the Class 2 and NNS components.

Technical requirements differences are discussed in Sections 5.1 through 5.3 below.

5.1 Material Examination and Piping Design

For piping and tubing material examinations and piping design, the differences between the currently-installed Class 2 components and the Class 1 requirements would be eliminated by including provisions from later editions and addenda of ASME Section III that have been approved for use in 10 CFR 50.55a. For piping and tubing material examination, the later provisions of NB-2510(a) in the Summer 1983 Addenda exempted one-inch diameter and less seamless pipe, tubes and fittings from the examination requirements of NB-2500, thus making the Class 1 rules the same as Class 2 and eliminating the technical difference.

For piping design, differences between Class 1 and Class 2 requirements in the 1971 Edition of the ASME Section III Code with addenda through Winter of 1972 were eliminated by the Summer 1975 Addenda change in NB-3630(d). This change allowed one-inch diameter and smaller Class I piping to be designed to NC-3600, thus making the smaller Class 1 piping design rules the same as Class 2 and eliminating the technical differences. The NRC accepted the Summer 1983 Addenda containing these material examination provisions and the Summer 1975 Addenda containing these piping design provisions in 10 CFR 50.55a. If the design and construction had taken place at a later point in time using the later addenda, the current Class 2 installed configuration would meet present-day Class 1 material examination and piping design requirements.

None of the piping or tubing in Part 1 of this request contain circumferential butt welds.

Therefore, no increase in quality or safety would be realized by upgrading the design and replacing piping and tubing with Class 1 components.

5.2 Valve Design

The 1971 Edition of the ASME Section III Code with addenda through Winter of 1972 requirements in NB-3500 for valve design are different than the requirements in NC-3500. However, the valves identified in Part 1 of this request were evaluated and found to meet the technical requirements in NB-3500 applicable to small valves (that is, valves having an inlet piping connection of four-inch nominal pipe size or less). Therefore, there are no technical differences between the installed Class 2 valves and the requirements for Class 1 valves that would reduce the assurance that the valves will perform their intended safety function.

No increase in quality and safety would be realized by replacing the valves with valves constructed to Class 1 requirements.

5.3 NNS Piping

The NNS piping is Class 1502 Schedule 160 SA-376 or SA-312. This piping meets the requirements of ASME Section III, Subsection NC-3600, for pipe design and has been analyzed to Class 2 requirements. All resultant stresses are below the maximum allowed.

During the fall 2015 refueling outage, the NNS socket welds were examined by the liquid penetrant method per NC-5250 and were satisfactory. A visual examination of the NNS piping was also performed, confirming heat numbers associated with Class 1 piping.

Therefore, no increase in quality and safety would be realized by replacing the NNS piping with Class 2 piping.

6. DURATION OF PROPOSED ALTERNATIVE

As this request relates to the design code, which has no interval period, rather than a request relating to the inservice code, which has intervals, FENOC requests approval of the proposed alternative for the life of the plant.

7. PRECEDENT

Southern Nuclear Operating Company, Inc. submitted a similar request for the Joseph M. Farley Nuclear Plant, Unit Nos. 1 and 2, requesting that affected piping, tubing, fittings, valves, and supports remain as designed and constructed in lieu of upgrading and replacing the components with Class 1 components. By letter dated January 18, 2012, (ADAMS Accession Number ML11347A005), the NRC staff authorized use of the alternative. FENOC request BV2-PZR-01 is similar, other than the affected components and an increase in scope to include NNS piping.

No. 10080-RM-0075B

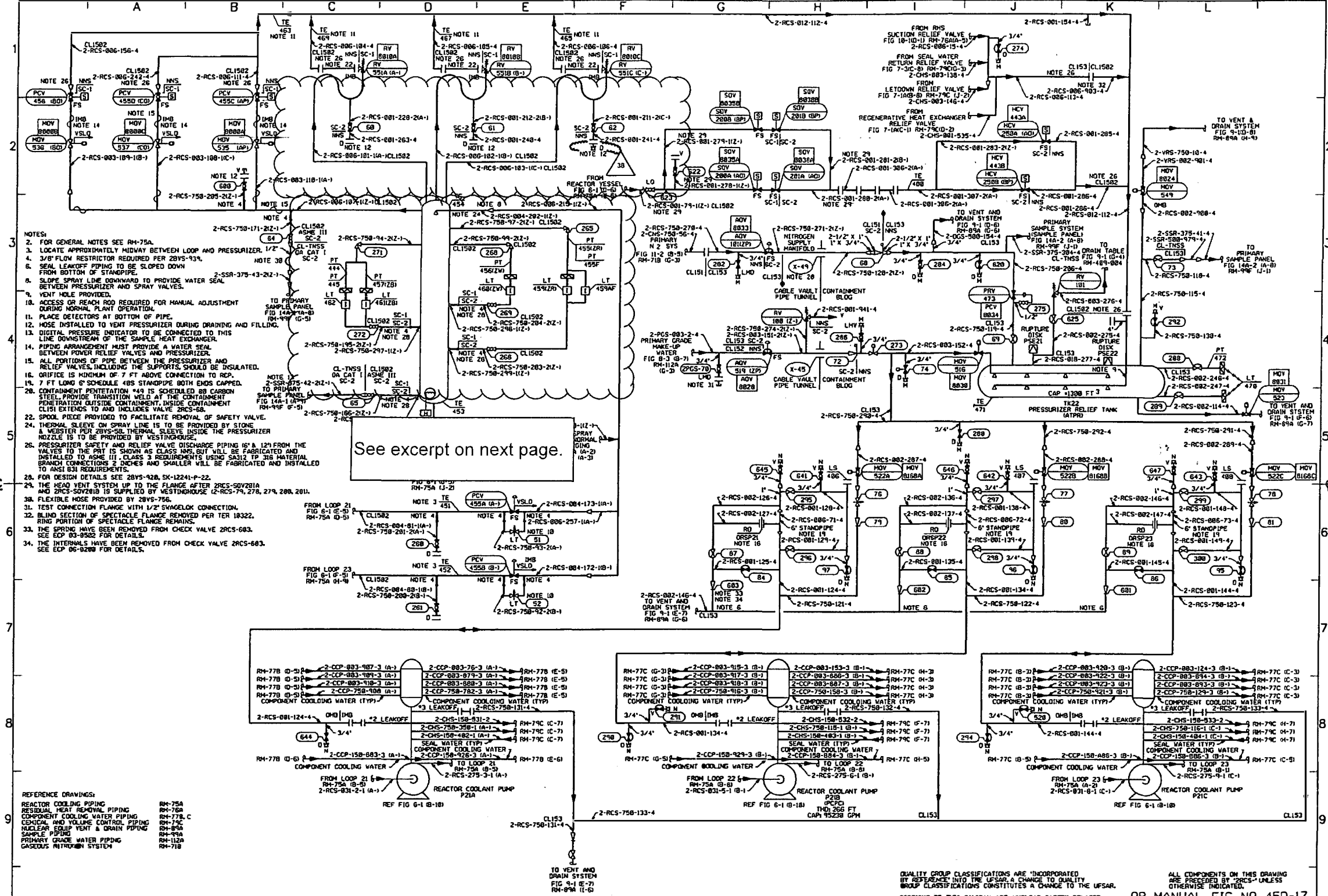

- NOTES:
- FOR GENERAL NOTES SEE RM-75A.
 - LOCATE APPROXIMATELY MIDWAY BETWEEN LOOP AND PRESSURIZER.
 - 3/8" FLOW RESTRICTOR REQUIRED PER 28V5-93A.
 - SEAL LEADOFF PIPING TO BE SLOPED DOWN FROM BOTTOM OF STANDPIPE.
 - SLOPE SPRAY LINE DOWNWARD TO PROVIDE WATER SEAL BETWEEN PRESSURIZER AND SPRAY VALVES.
 - VENT NOLE PROVIDED.
 - ACCESS OR REACH ROD REQUIRED FOR MANUAL ADJUSTMENT DURING NORMAL PLANT OPERATION.
 - PLACE DETECTORS AT BOTTOM OF PIPE.
 - HOSE INSTALLED TO VENT PRESSURIZER DURING DRAINING AND FILLING.
 - DIGITAL PRESSURE INDICATOR TO BE CONNECTED TO THIS LINE DOWNSTREAM OF THE SAMPLE HEAT EXCHANGER.
 - GRIPICE IS MINIMUM OF 7 FT ABOVE CONNECTION TO REP.
 - 7 FT LONG 6" SCHEDULE 40S STANDPIPE BOTH ENDS CAPPED.
 - CONTAINMENT PENETRATION #49 IS SCHEDULE 80 CARBON STEEL PROVIDE TRANSITION WELD AT THE CONTAINMENT PENETRATION OUTSIDE CONTAINMENT, INSIDE CONTAINMENT CL153 EXTENDS TO AND INCLUDES VALVE 2RCS-68.
 - SPOOL PIECE PROVIDED TO FACILITATE REMOVAL OF SAFETY VALVE.
 - THERMAL SLEEVE ON SPRAY LINE IS TO BE PROVIDED BY STONE & WEBSTER PER 28V5-93A THERMAL SLEEVE INSIDE THE PRESSURIZER NOZZLE IS TO BE PROVIDED BY WESTINGHOUSE.
 - PRESSURIZER SAFETY AND RELIEF VALVE DISCHARGE PIPING 6" & 12" FROM THE VALVES TO THE PRT IS SHOWN AS CLASS 1MS, BUT WILL BE FABRICATED AND INSTALLED TO ASME III, CLASS 3 REQUIREMENTS USING SA312 TP 316 MATERIAL BRANCH CONNECTIONS 2 INCHES AND SMALLER WILL BE FABRICATED AND INSTALLED TO ANSI B31 REQUIREMENTS.
 - FOR DESIGN DETAILS SEE 28V5-92B, SK-12241-P-22.
 - THE HEAD VENT SYSTEM UP TO THE FLANGE AFTER 2RCS-50V201A AND 2RCS-50V201B IS SUPPLIED BY WESTINGHOUSE (2-RCS-79, 278, 279, 280, 281).
 - FLEXIBLE HOSE PROVIDED BY 28V5-756.
 - TEST CONNECTION FLANGE WITH 1/2" SWAGelok CONNECTION.
 - BLIND SECTION OF SPECTACLE FLANGE REMOVED PER 18322.
 - RING PORTION OF SPECTACLE FLANGE REMAINS.
 - THE SPRING HAS BEEN REMOVED FROM CHECK VALVE 2RCS-683. SEE ECP 83-8502 FOR DETAILS.
 - THE INTERNALS HAVE BEEN REMOVED FROM CHECK VALVE 2RCS-683. SEE ECP 85-8289 FOR DETAILS.

- REFERENCE DRAWINGS:
- REACTOR COOLING PIPING RM-75A
 - RESIDUAL HOSE REMOVAL PIPING RM-75B
 - COMPONENT COOLING WATER PIPING RM-77B, C
 - CENTRAL HOSE CONTROL PIPING RM-79C
 - NUCLEAR EQUIP VENT & DRAIN PIPING RM-85A
 - SAMPLE PIPING RM-95A
 - PRIMARY GRADE WATER PIPING RM-122A
 - GASEOUS NITROGEN SYSTEM RM-718

QUALITY GROUP CLASSIFICATIONS ARE INCORPORATED BY REFERENCE INTO THE UFSAR. A CHANGE TO QUALITY GROUP CLASSIFICATIONS CONSTITUTES A CHANGE TO THE UFSAR. ALL COMPONENTS ON THIS DRAWING ARE PROVIDED BY 2RCS-UNLESS OTHERWISE INDICATED.

PORTIONS OF THIS DIAGRAM ARE NUCLEAR SAFETY RELATED. OP MANUAL FIG NO 450-17

REVISION 30 INCORPORATED JUN 14 1988-001-003

FENOC FIRST ENERGY NUCLEAR OPERATING COMPANY

BEAVER VALLEY POWER STATION UNIT 2
FLOW DIAGRAM
REACTOR COOLANT PIPING SH 2

AA 10080-RM-0075B 38

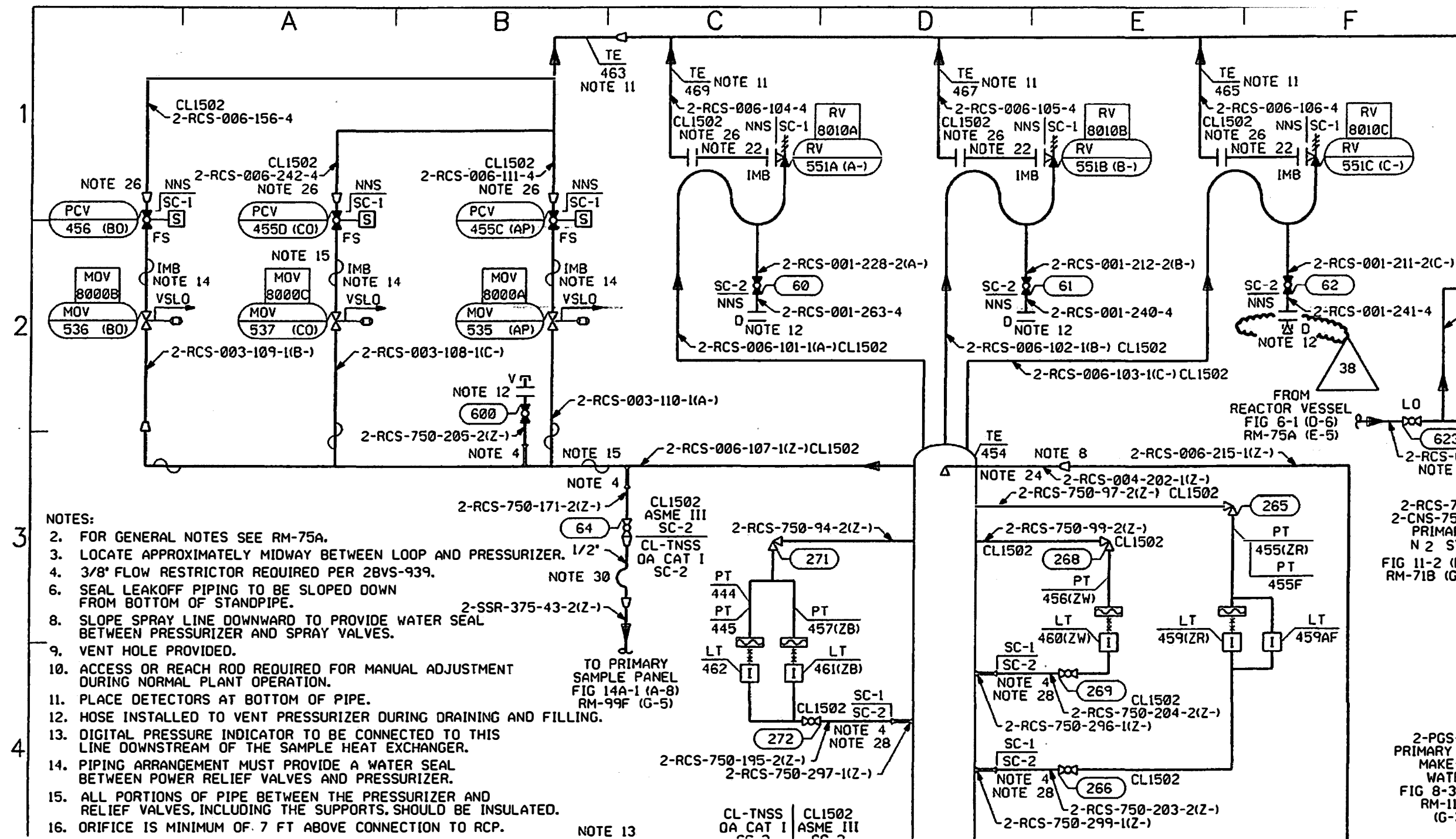

2-RCS-71
 2-CNS-751
 PRIMAR
 N 2 S1
 FIG 11-2 (E
 RM-71B (G)

2-PGS-
 PRIMARY
 MAKE-
 WATE
 FIG 8-3
 RM-11
 (G-: