

Regulatory Review Process Options for Advanced non-LWR Designs

Deborah Jackson, Deputy Director
Division of Engineering, Infrastructure,
and Advanced Reactors
June 7, 2016

Introduction

Why we are developing options for regulatory review processes:

- To respond to non-LWR Industry needs
- To provide flexibility for stakeholders
- To become familiar with new designs and technologies
- To gain information on industry plans early

Review Processes

Review process options utilize the NRC's existing regulatory framework:

- Design Review Processes
- Licensing Review Processes
- New Regulatory Framework (future)

NRC Licensing Pathways for Reactor Technologies

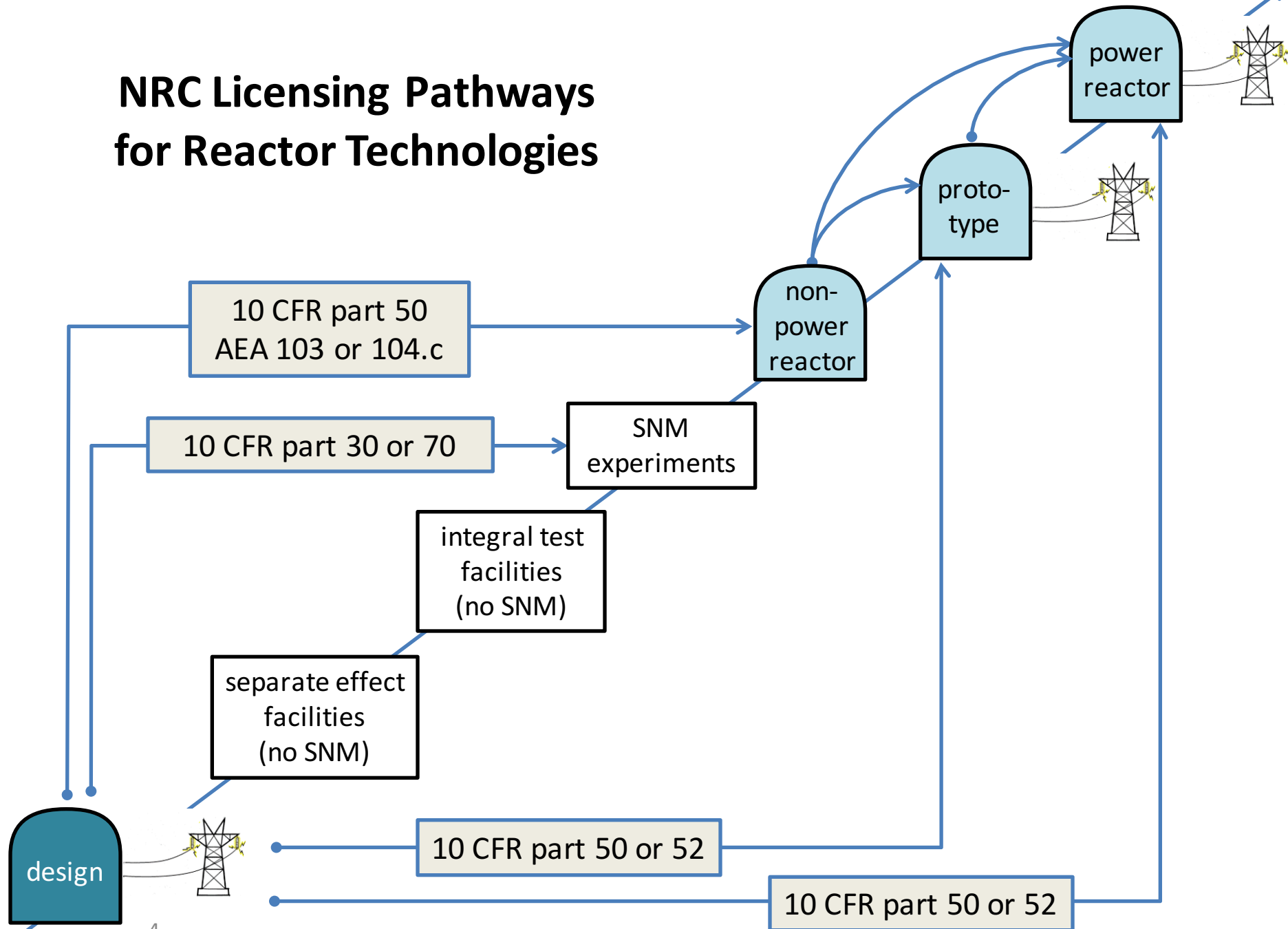

NRC Design Review Processes

DR Process 1 – Letters/ White Papers / Technical Reports / Topical Reports – Provide varying degrees of feedback on regulatory or technical topics

DR Process 2 – Pre-app Readiness Reviews, Pre-app Audits – Provide feedback prior to submitting an application

DR Process 3 – Conceptual Design Assessment – Provides early design phase regulatory feedback on potential technical risks and regulatory challenges

DR Process 4 – Staged Design Review - Utilizes elements of the Standard Design Approval to package discrete sections of the application for review by NRC

DR Process 5 – Preliminary Design Review – Pre-application SER similar to PRISM, SAFR, HTGR, etc.

DR Process 6 – Standard Design Approval – 10 CFR Part 52 Subpart E

DR Process 7 – Standard Design Certification – 10 CFR Part 52 Subpart B

Key:

Green: New Process

Yellow: Existing Process

DR Process 3 – Conceptual Design Assessment Preliminary/Early Design

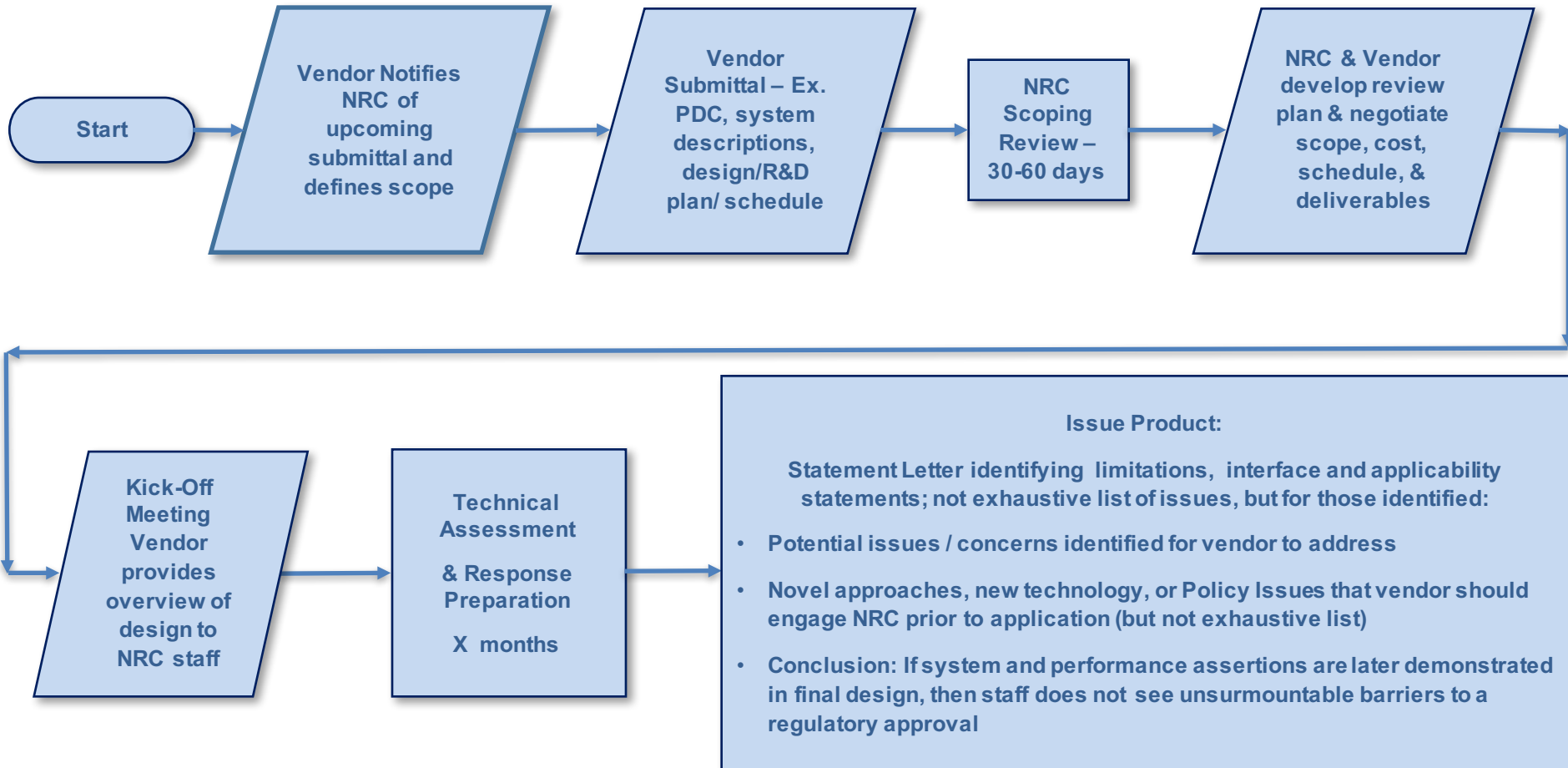

DR Process 4 – Staged Design Review Using Standard Design Approval (SDA)

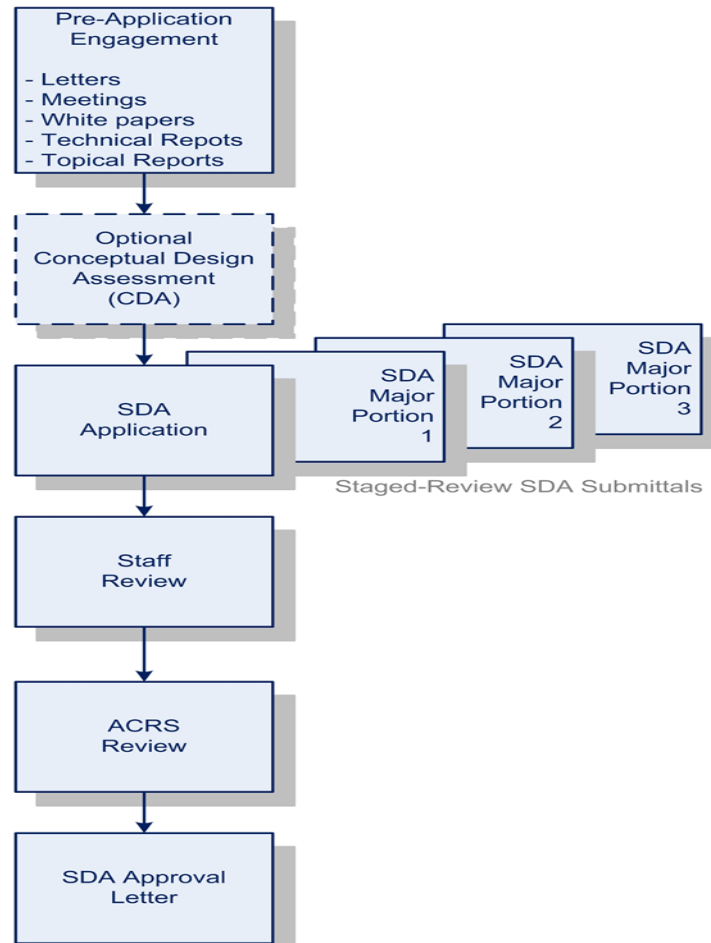

NRC Licensing Review Process Options

LIC Option 1a – Part 50 (CP and OL, LWA) Application

LIC Option 1b – Part 50 (CP and OL, LWA) Application for a Prototype Reactor

LIC Option 2a – Part 52 (COL, DC, ESP, LWA) Application

LIC Option 2b – Part 52 (COL, DC, ESP, LWA) Application for a Prototype Reactor

Future New Risk Informed Performance Based (RI/BP) Technology Neutral Framework (if/when available):

LIC Option 3a – New “Part XX” RI/ PB - Application

LIC Option 3b – New “Part XX” RI/ PB – for a Prototype Reactor

Key:

Green: New Process

Yellow: Existing Process

Licensing Options with Prototype

- Prototype reactors definition:

Prototype plant means a nuclear power plant that is used to test new safety features, such as the testing required under 10 CFR 50.43(e). The prototype plant is similar to a first-of-a-kind or standard plant design in all features and size, but may include additional safety features to protect the public and the plant staff from the possible consequences of accidents during the testing period.

- Prototype reactors can be licensed under 10 CFR Part 50 or 52
 - Mostly applicable to commercial part 103 licenses
 - Can be a “scaled down” version of standard plant
 - Test results linked to prototype plant license conditions
-

Licensing Options Under New RI/PB Framework

- NEW FUTURE process codified by NEW regulation
- Fully risk-informed/performance based
- Technology neutral to both LWR and Non-LWR technologies

Conclusion

- NRC is developing new processes to respond to the needs of stakeholders
- Near term processes utilize the existing regulatory framework to respond to near term needs
- Future long term risk-informed performance-based technology neutral process is envisioned