

2.12 Station Electrical Systems

The information in this section of the reference ABWR DCD, including all subsections, figures and tables, is incorporated by reference with the following departures.

STD DEP T1 2.12-1 (Tables 2.12.1, 2.12.12, 2.12.14 and 2.12.15)

STD DEP T1 2.12-2 (Figure 2.12.15)

STD DEP Vendor

2.12.1 Electrical Power Distribution System

Design Description

STD DEP T1 2.12-1

EPD System interrupting devices (circuit breakers and fuses) are coordinated to the maximum extent possible, so that the circuit interrupter closest to the fault opens before other devices. For instances where coordination cannot be practically achieved, analysis will justify the lack of coordination.

Interface Requirements

STD DEP Vendor

The independence of offsite transmission power, instrumentation, and control circuits shall be compatible with the portion of the offsite transmission power, instrumentation, and control circuits within GE's Engineering, Procurement, and Construction (EPC) vendor's design scope.

Instrumentation and control system loads shall be compatible with the capacity and capability design requirements of DC systems within GE's EPC vendor's design scope.

2.12.12 Direct Current Power Supply

Design Description

STD DEP T1 2.12-1

Class 1E DC electrical distribution system circuit interrupting devices (circuit breakers and fuses) are coordinated to the maximum extent possible, so that the circuit interrupter closest to the fault opens before other devices. For instances where coordination cannot be practically achieved, analysis will justify the lack of coordination.

2.12.14 Vital AC Power Supply

Design Description

STD DEP T1 2.12-1

Class 1E Vital AC Power Supply system interrupting devices (circuit breakers and fuses) are coordinated to the maximum extent possible, so that the circuit interrupter closest to the fault opens before other devices. For instances where coordination cannot be practically achieved, analysis will justify the lack of coordination.

2.12.15 Instrument and Control Power Supply

Design Description

STD DEP T1 2.12-2

The Class 1E Instrument and Control Power Supply consists of ~~three~~ four divisions (Division I, II, ~~and III, and IV~~) of interruptible power supplies with their respective distribution panels. Each Class 1E power supply provides interruptible, regulated AC power to Class 1E circuits which do not require continuity of power during a loss of preferred power (LOPP).

STD DEP T1 2.12-1

Class 1E Instrument and Control Power Supply system interrupting devices (circuit breakers and fuses) are coordinated to the maximum extent possible, so that the circuit interrupter closest to the fault opens before other devices. For instances where coordination cannot be practically achieved, analysis will justify the lack of coordination.

**Table 2.12.1 Electric Power Distribution System
Inspections, Tests, Analyses and Acceptance Criteria**

Design Commitment	Inspections, Tests, Analyses	Acceptance Criteria
<p>11. EPD System interrupting devices (circuit breakers and fuses) are coordinated to the maximum extent possible, so that the circuit interrupter closest to the fault opens before other devices.</p>	<p>11. Analyses for the as-built EPD System to determine circuit interrupting device coordination will be performed.</p>	<p>11. Analyses for the as-built EPD System exist and conclude that, to the maximum extent possible, the analyzed circuit interrupter closest to the fault will open before other devices. For instances where coordination cannot be practically achieved, the analysis will justify the lack of coordination.</p>
<p>22. The EPD System supplies an operating voltage at the terminals of the Class 1E utilization equipment that is within the utilization equipment's voltage tolerance limits.</p>	<p>22.</p> <ul style="list-style-type: none"> a. Analyses for the as-built EPD System to determine voltage drops will be performed. b. Tests of the as-built Class 1E EPD System will be conducted by operating connected Class 1E loads at their analyzed minimum voltage. b. Type tests at manufacturer's shop will be performed for the operating voltage range of the Class 1E electrical equipment. 	<p>22.</p> <ul style="list-style-type: none"> a. Analyses for the as-built EPD System exist and conclude that the analyzed operating voltage supplied at the terminals of the Class 1E utilization equipment is within the utilization equipment's voltage tolerance limits, as determined by their nameplate ratings. b. Connected Class 1E loads operate at their analyzed minimum voltage, as determined by the voltage drop analyses. b. Manufacturer's type test reports exist and conclude that the operating range is within the tested voltage range for the Class 1E electrical equipment.

Table 2.12.1 Electric Power Distribution System (Continued)

Inspections, Tests, Analyses and Acceptance Criteria		
Design Commitment	Inspections, Tests, Analyses	Acceptance Criteria
	<p>c. System preoperational and Startup tests will be conducted of the as-built Class 1E EPD System.</p>	<p>c. The test voltages from preoperational test reports are compared against system voltage analysis of the as-built Class 1E EPD system. The results of comparison conclude that the available voltage is within the operating range for the as-installed equipment.</p>

Table 2.12.12 Direct Current Power Supply

Inspections, Tests, Analyses and Acceptance Criteria		
Design Commitment	Inspections, Tests, Analyses	Acceptance Criteria
8. Class 1E DC electrical distribution system circuit interrupting devices (circuit breakers and fuses) are coordinated to the maximum extent possible , so that the circuit interrupter closest to the fault opens before other devices.	8. Analyses for the as-built Class 1E DC electrical distribution system to determine circuit interrupting device coordination will be performed.	8. Analyses for the as-built Class 1E DC electrical distribution system circuit interrupting devices exist and conclude that, to the maximum extent possible , the analyzed circuit interrupter closest to the fault will open before other devices. For instances where coordination cannot be practically achieved, the analysis will justify the lack of coordination.

Table 2.12.12 Direct Current Power Supply (Continued)

Inspections, Tests, Analyses and Acceptance Criteria		
Design Commitment	Inspections, Tests, Analyses	Acceptance Criteria
<p>11. The Class 1E DC electrical distribution system supplies an operating voltage at the terminals of the Class 1E utilization equipment that is within the utilization equipment's voltage tolerance limits.</p>	<p>11.</p> <ul style="list-style-type: none"> a. Analyses for the as-built Class 1E DC electrical distribution system to determine system voltage drops will be performed. b. Tests of the as-built Class 1E DC system will be conducted by operating connected Class 1E loads at less than or equal to the minimum allowable battery voltage and at greater than or equal to the maximum battery charging voltage. b. Type tests at manufacturer's shop will be performed for the operating voltage range of the Class 1E DC electrical equipment. c. System preoperational tests will be conducted on the as-built Class 1E DC system. 	<p>11.</p> <ul style="list-style-type: none"> a. Analyses for the as-built Class 1E DC electrical distribution system exist and conclude that the analyzed operating voltage supplied at the terminals of the Class 1E utilization equipment is within the utilization equipment's voltage tolerance limits, as determined by their nameplate ratings. b. Connected as-built Class 1E loads operate at less than or equal to the minimum allowable battery voltage and at greater than or equal to the maximum battery charging voltage. b. Manufacturer's type test reports exist and conclude that the operating range is within the tested voltage range for the Class 1E DC electrical equipment. c. The test voltages from preoperational test reports are compared against system voltage analysis of the as-built Class 1E EPD system. The results of comparison conclude that the available voltage is within the operating range for the as-installed DC equipment.

Table 2.12.14 Vital AC Power Supply

Inspections, Tests, Analyses and Acceptance Criteria		
Design Commitment	Inspections, Tests, Analyses	Acceptance Criteria
<p>10. Class 1E Vital AC Power Supply system interrupting devices (circuit breakers and fuses) are coordinated to the maximum extent possible, so that the circuit interrupter closest to the fault opens before other devices.</p>	<p>10. Analyses for the as-built Class 1E distribution system to determine circuit interrupting device coordination will be performed.</p>	<p>10. Analyses for the as-built Class 1E Vital AC Power Supply system circuit interrupting devices (circuit breakers and fuses) coordination exist and conclude that, to the maximum extent possible, the analyzed circuit interrupter closest to the fault will open before other devices. For instances where coordination cannot be practically achieved, the analysis will justify the lack of coordination.</p>

Table 2.12.15 Instrument and Control Power Supply

Inspections, Tests, Analyses and Acceptance Criteria		
Design Commitment	Inspections, Tests, Analyses	Acceptance Criteria
<p>9. Class 1E Instrument and Control Power Supply system interrupting devices (circuit breakers and fuses) are coordinated to the maximum extent possible, so that the circuit interrupter closest the fault opens before other devices.</p>	<p>9. Analyses for the as-built Class 1E distribution system to determine circuit interrupting device coordination will be performed.</p>	<p>9. Analyses for the as-built Class 1E Instrument and Control Power Supply system circuit interrupting devices (circuit breakers and fuses) coordination exist and conclude that, to the maximum extent possible, the analyzed circuit interrupter closest to the fault will open before other devices. For instances where coordination cannot be practically achieved, the analysis will justify the lack of coordination.</p>

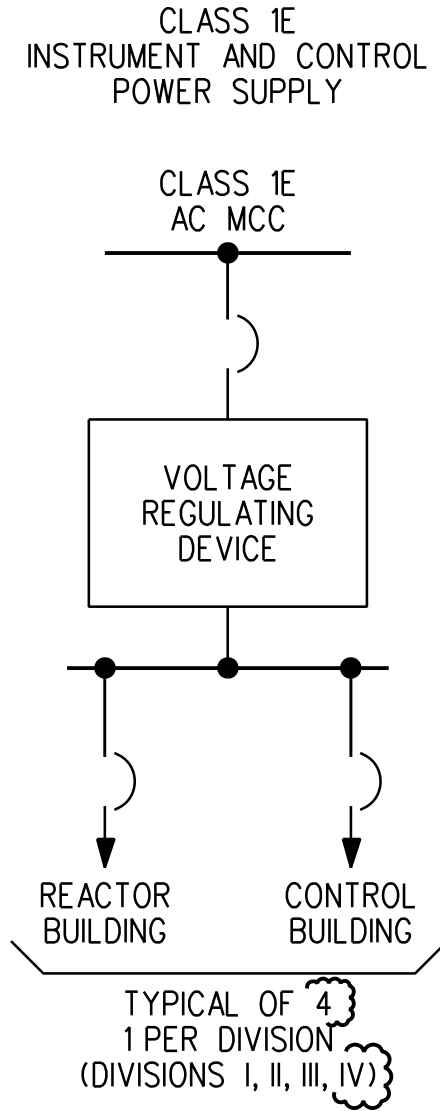

Figure 2.12.15 Instrument and Control Power Supply

