RESPONSE TO REQUEST FOR ADDITIONAL INFORMATION

APR1400 Design Certification

Korea Electric Power Corporation / Korea Hydro & Nuclear Power Co., LTD

Docket No. 52-046

RAI No.: 357-8344
SRP Section: 06.02.04 - Containment Isolation System
Application Section: Section 6.2.4
Date of RAI Issue: 01/05/2016

Question No. 06.02.04-4

Clarify if all power operated containment isolation valves (CIVs) have position indication in the main control room (MCR) and have station blackout (SBO) considerations for indication and closure.

Pursuant to the RG 1.141 and ANSI N271-1976, Section 4.2.3 guidance, provide a description in the DCD that states that all power operated isolation valves have position indication in the MCR. In addition, pursuant to RG 1.155 Section C.3.2.7, indicate in the DCD if provisions are provided, independent of the preferred and blacked out unit's onsite emergency ac power supplies, for valve position indication and closure for containment isolation valves that may be in the open position at the onset of a SBO.

Response

All power operated CIVs in Table 6.2.4-1 are provided with open/close position indication on the operator console and the safety console in the MCR. These consoles and safety related component control cabinets are continuously powered from 120Vac supplies, which are backed up by the station batteries or alternate AC (AAC) power supply. Therefore, the MCR operator can monitor the CIVs position even if the onsite emergency ac power is not available.

The closure for CIVs at the onset of a SBO is described in the table below. DCD, Tier 2 Section 6.2.4.1.2 will be revised accordingly.

In addition, Table 9.2.2-6 and Figure 9.2.2-1 will be revised to correct the power segregation for Valves CC-231, 249, and 250.

Valve No.	Actuator type ⁽¹⁾	Power	Normal Power Train	Emergency Power Train ⁽²⁾	AAC Power Train ⁽²⁾⁽³⁾	Closure for CIVs at the onset of a SBO
MS-091	P	125Vdc	AE, BE	AE, BE	AE, BE	Closure is available independent of SBO because this valve is powered from a station battery which is independent from AC power.
MS-012	EH	125Vdc	AE, BE	AE, BE	AE, BE	Closure is available independent of SBO because this valve is powered from a station battery which is independent from AC power.
MS-102	EH	125Vdc 480Vac	AE, CE	AE, CE	AE	Closure is available independent of Station Black Out because this valve is powered from a station battery which is independent from AC power. This valve is excluded for closure at the onset of a SBO, since this valve is included in fail-closed valves as stated in RG 1.155 Position 3.2.7.
MS-016	EH	125Vdc	AE, BE	AE, BE	AE, BE	Closure is available independent of SBO because this valve is powered from a station battery which is independent from AC power.
MS-090	P	125Vdc	AE, BE	AE, BE	AE, BE	Closure is available independent of SBO because this valve is powered from a station battery which is independent from AC power.
MS-011	EH	125Vdc	AE, BE	AE, BE	AE, BE	Closure is available independent of SBO because this valve is powered from a station battery which is independent from AC power.
MS-101	EH	125Vdc 480Vac	BE, DE	BE, DE	BE	Closure is available independent of Station Black Out because this valve is powered from a station battery which is independent from AC power. This valve is excluded for closure at the onset of a SBO, since this valve is included in fail-closed valves as stated in RG 1.155 Position 3.2.7.
MS-0110	P	125Vdc	BE	BE	BE	Closure is available independent of SBO because this valve is powered from a station battery which is independent from AC power.
MS-015	EH	125Vdc	AE, BE	AE, BE	AE, BE	Closure is available independent of SBO because this valve is powered from a station battery which is independent from AC power.
MS-0112	P	125Vdc	BE	BE	BE	Closure is available independent of SBO because this valve is powered from a station battery which is independent from AC power.
MS-093	P	125Vdc	AE, BE	AE, BE	AE, BE	Closure is available independent of SBO because this valve is powered from a station battery which is independent from AC power.
MS-014	EH	125Vdc	AE, BE	AE, BE	AE, BE	Closure is available independent of SBO because this valve is powered from a station battery which is independent from AC power.

Valve No.	Actuator type ⁽¹⁾	Power	Normal Power Train	Emergency Power Train ⁽²⁾	AAC Power Train ⁽²⁾⁽³⁾	Closure for CIVs at the onset of a SBO
MS-104	EH	125Vdc 480Vac	BE, DE	BE, DE	BE	Closure is available independent of Station Black Out because this valve is powered from a station battery which is independent from AC power. This valve is excluded for closure at the onset of a SBO, since this valve is included in fail-closed valves as stated in RG 1.155 Position 3.2.7.
MS-109	P	125Vdc	AE	AE	AE	Closure is available independent of SBO because this valve is powered from a station battery which is independent from AC power.
MS-111	P	125Vdc	AE	AE	AE	Closure is available independent of SBO because this valve is powered from a station battery which is independent from AC power.
MS-018	EH	125Vdc	AE, BE	AE, BE	AE, BE	Closure is available independent of SBO because this valve is powered from a station battery which is independent from AC power.
MS-013	EH	125Vdc	AE, BE	AE, BE	AE, BE	Closure is available independent of SBO because this valve is powered from a station battery which is independent from AC power.
MS-103	EH	125Vdc 480Vac	AE, CE	AE, CE	AE	Closure is available independent of Station Black Out because this valve is powered from a station battery which is independent from AC power. This valve is excluded for closure at the onset of a SBO, since this valve is included in fail-closed valves as stated in RG 1.155 Position 3.2.7.
MS-017	EH	125Vdc	AE, BE	AE, BE	AE, BE	Closure is available independent of SBO because this valve is powered from a station battery which is independent from AC power.
MS-092	P	125Vdc	AE, BE	AE, BE	AE, BE	Closure is available independent of SBO because this valve is powered from a station battery which is independent from AC power.
FW-131	EH	125Vdc	AE	AE	AE	Closure is available independent of SBO because this valve is powered from a station battery which is independent from AC power.
FW-132	EH	125Vdc	BE	BE	BE	Closure is available independent of SBO because this valve is powered from a station battery which is independent from AC power.
FW-133	EH	125Vdc	AE	AE	AE	Closure is available independent of SBO because this valve is powered from a station battery which is independent from AC power.
FW-134	EH	125Vdc	BE	BE	BE	Closure is available independent of SBO because this valve is powered from a station battery which is independent from AC power.

Valve No.	Actuator type ⁽¹⁾	Power	Normal Power Train	Emergency Power Train ⁽²⁾	AAC Power Train ^{(2) (3)}	Closure for CIVs at the onset of a SBO
FW-121	EH	125Vdc	AE	AE	AE	Closure is available independent of SBO because this valve is powered from a station battery which is independent from AC power.
FW-122	EH	125Vdc	BE	BE	BE	Closure is available independent of SBO because this valve is powered from a station battery which is independent from AC power.
FW-123	EH	125Vdc	AE	AE	AE	Closure is available independent of SBO because this valve is powered from a station battery which is independent from AC power.
FW-124	EH	125Vdc	BE	BE	BE	Closure is available independent of SBO because this valve is powered from a station battery which is independent from AC power.
FW-138	P	125Vdc	AE	AE	AE	Closure is available independent of SBO because this valve is powered from a station battery which is independent from AC power.
FW-139	P	125Vdc	BE	BE	BE	Closure is available independent of SBO because this valve is powered from a station battery which is independent from AC power.
AF-0043	E	125Vdc	AE	AE	AE	This valve is excluded for closure at the onset of a SBO, because this valve is included in nonradioactive closed loop system as stated in RG 1.155 Position 3.2.7.
AF-0046	E	125Vdc	DE	DE	NONE	Closure is available independent of SBO because this valve is powered from a station battery which is independent from AC power.
AF-0044	E	125Vdc	BE	BE	BE	This valve is excluded for closure at the onset of a SBO, because this valve is included in nonradioactive closed loop system as stated in RG 1.155 Position 3.2.7.
AF-0045	E	125Vdc	CE	CE	NONE	Closure is available independent of SBO because this valve is powered from a station battery which is independent from AC power.
SI-616	E	480Vac	DE	DE	NONE	For SI-616, closure is unavailable when SBO occurs. However, containment isolation can be accomplished, because the SI-616 installed in the safety injection (SI) train #4 is closed during normal operation and check valve SI-113 is installed inside the containment building in series with SI-616 as double containment isolation barriers.

Valve No.	Actuator type ⁽¹⁾	Power	Normal Power Train	Emergency Power Train ⁽²⁾	AAC Power Train ⁽²⁾⁽³⁾	Closure for CIVs at the onset of a SBO
SI-600	E	480Vac	BE	BE	BE	<p>For one valve of SI-600 and SI-601, closure is unavailable when SBO occurs.</p> <p>The other valve can be closed with back up from AAC, if necessary. In addition, containment isolation can be accomplished, because the SI-600 is normally closed during normal operation and check valve SI-123 is installed inside the containment building in series with SI-600 as double containment isolation barriers.</p>
SI-602	E	480Vac	BE	BE	BE	<p>This valve is excluded from the 'appropriate containment integrity for SBO consideration', since this valve has less than 3 inch nominal diameter (RG 1.155 Section C.3.2.7).</p>
SI-626	E	480Vac	BE	BE	BE	<p>For one valve of SI-626 and SI-646, closure is unavailable when SBO occurs. The other valve can be closed with back up from AAC, if necessary.</p> <p>In addition, containment isolation can be accomplished because the SI-626 installed in the safety injection (SI) train #2 is closed during normal operation, and check valve SI-123 is installed inside the containment building in series with SI-626 as double containment isolation barriers.</p>
SI-636	E	480Vac	CE	CE	NONE	<p>For SI-636, closure is unavailable when SBO occurs.</p> <p>However, containment isolation can be accomplished, because the SI-636 installed in the safety injection (SI) train #3 is closed during normal operation and check valve SI-133 is installed inside the containment building in series with SI-636 as double containment isolation barriers.</p>

Valve No.	Actuator type ⁽¹⁾	Power	Normal Power Train	Emergency Power Train ⁽²⁾	AAC Power Train ^{(2) (3)}	Closure for CIVs at the onset of a SBO
SI-601	E	480Vac	AE	AE	AE	<p>For one valve of SI-600 and SI-601, closure is unavailable when SBO occurs. The other valve can be closed with back up from AAC, if necessary.</p> <p>In addition, containment isolation can be accomplished because the SI-601 is normally closed during normal operation, and check valve SI-143 is installed inside the containment building in series with SI-601 as double containment isolation barriers.</p>
SI-603	E	480Vac	AE	AE	AE	This valve is excluded from the 'appropriate containment integrity for SBO consideration', since this valve has less than 3 inch nominal diameter (RG 1.155 Section C.3.2.7).
SI-646	E	480Vac	AE	AE	AE	<p>For one valve of SI-626 and SI-646, closure is unavailable when SBO occurs. The other valve can be closed with back up from AAC, if necessary.</p> <p>In addition, containment isolation can be accomplished, because the SI-646 installed in the safety injection (SI) train #1 is closed during normal operation and check valve SI-143 is installed inside the containment building in series with SI-646 as double containment isolation barriers.</p>
SI-654	E	125Vdc	DE	DE	NONE	This valve is excluded from the 'appropriate containment integrity for SBO consideration', since this valve is normally locked closed during operation (RG 1.155 Section C.3.2.7).
SI-656	E	480Vac	BE	BE	BE	This valve is excluded from the 'appropriate containment integrity for SBO consideration', since this valve is normally locked closed during operation (RG 1.155 Section C.3.2.7).
SI-653	E	125Vdc	CE	CE	NONE	This valve is excluded from the 'appropriate containment integrity for SBO consideration', since this valve is normally locked closed during operation (RG 1.155 Section C.3.2.7).

Valve No.	Actuator type ⁽¹⁾	Power	Normal Power Train	Emergency Power Train ⁽²⁾	AAC Power Train ⁽²⁾⁽³⁾	Closure for CIVs at the onset of a SBO
SI-655	E	480Vac	AE	AE	AE	This valve is excluded from the 'appropriate containment integrity for SBO consideration', since this valve is normally locked closed during operation (RG 1.155 Section C.3.2.7).
SI-331	E	125Vdc	DE	DE	NONE	This valve is excluded from the 'appropriate containment integrity for SBO consideration', since this valve is normally locked closed during operation (RG 1.155 Section C.3.2.7).
SI-321	E	125Vdc	CE	CE	NONE	This valve is excluded from the 'appropriate containment integrity for SBO consideration', since this valve is normally locked closed during operation (RG 1.155 Section C.3.2.7).
CS-004	E	480Vac	DE	DE	NONE	The MOV is normally closed in the normal operation and fails in the as-is (closed) position.
CS-003	E	480Vac	CE	CE	NONE	The MOV is normally closed in the normal operation and fails in the as-is (closed) position.
SI-304	E	480Vac	AE	AE	AE	For one valve of SI-304 and SI-305, closure is unavailable when SBO occurs. The other valve can be closed with back up from AAC, if necessary. The valve is normally locked open during normal operation to increase and protect functionality of SIP.
SI-305	E	480Vac	BE	BE	BE	For one valve of SI-304 and SI-305, closure is unavailable when SBO occurs. The other valve can be closed with back up from AAC, if necessary. The valve is normally locked open during normal operation to increase and protect functionality of SIP.
SI-308	E	480Vac	CE	CE	NONE	Closure is unavailable when SBO occurs. The valve is normally locked open during normal operation to increase and protect functionality of SIP.

Valve No.	Actuator type ⁽¹⁾	Power	Normal Power Train	Emergency Power Train ⁽²⁾	AAC Power Train ^{(2) (3)}	Closure for CIVs at the onset of a SBO
SI-309	E	480Vac	DE	DE	NONE	<p>Closure is unavailable when SBO occurs.</p> <p>The valve is normally locked open during normal operation to increase and protect functionality of SIP.</p>
SI-300	E	480Vac	AE	AE	AE	<p>For one valve of SI-300 and SI-301, closure is unavailable when SBO occurs. The other valve can be closed with back up from AAC, if necessary.</p> <p>In addition, containment isolation can be accomplished because the SI-300 is closed during normal operation and the check valve SI-100 is installed inside the containment building in series with SI-300 as double containment isolation barriers.</p>
SI-302	E	480Vac	AE	AE	AE	<p>For one valve of SI-302 and SI-303, closure is unavailable when SBO occurs. The other valve can be closed with back up from AAC, if necessary.</p> <p>In addition, containment isolation can be accomplished because the check valve SI-100 is installed inside the containment building in series with SI-302 as double containment isolation barriers.</p>
SI-301	E	480Vac	BE	BE	BE	<p>For one valve of SI-300 and SI-301, closure is unavailable when SBO occurs. The other valve can be closed with back up from AAC, if necessary.</p> <p>In addition, containment isolation can be accomplished because the SI-301 is closed during normal operation and the check valve SI-101 is installed inside the containment building in series with SI-301 as double containment isolation barriers.</p>

Valve No.	Actuator type ⁽¹⁾	Power	Normal Power Train	Emergency Power Train ⁽²⁾	AAC Power Train ⁽²⁾⁽³⁾	Closure for CIVs at the onset of a SBO
SI-303	E	480Vac	BE	BE	BE	For one valve of SI-302 and SI-303, closure is unavailable when SBO occurs. The other valve can be closed with back up from AAC, if necessary. In addition, containment isolation can be accomplished because the check valve SI-101 is installed inside the containment building in series with SI-303 as double containment isolation barriers.
SI-682	P	125Vdc	BE	BE	BE	This valve is excluded from the 'appropriate containment integrity for SBO consideration', since this valve fails close on a loss of power (RG 1.155 Section C.3.2.7).
CC-0296	E	480Vac	AE	AE	AE	The MOV is normally open in the normal operation and fails in the as-is (open) position. One of the valves CC-296 and CC-297 can be closed with back up from corresponding AAC power train when containment isolation function is required.
CC-0297	E	480Vac	BE	BE	BE	The MOV is normally open in the normal operation and fails in the as-is (open) position. One of the valves CC-296 and CC-297 can be closed with back up from corresponding AAC power train when containment isolation function is required.
CC-0301	E	480Vac	BE	BE	BE	The MOV is normally open in the normal operation and fails in the as-is (open) position. One of the valves CC-301 and CC-302 can be closed with back up from corresponding AAC power train when containment isolation function is required.
CC-0302	E	480Vac	AE	AE	AE	The MOV is normally open in the normal operation and fails in the as-is (open) position. One of the valves CC-301 and CC-302 can be closed with back up from corresponding AAC power train when containment isolation function is required.
CC-231	E	480Vac	CE	CE	NONE	The MOV is normally open in the normal operation and fails in the as-is (open) position. The check valve CC-1099, located in downstream of the valve CC-0231, can be closed when containment isolation function is required.

Valve No.	Actuator type ⁽¹⁾	Power	Normal Power Train	Emergency Power Train ⁽²⁾	AAC Power Train ^{(2) (3)}	Closure for CIVs at the onset of a SBO
CC-0250	E	480Vac	CE	CE	NONE	The MOV is normally open in the normal operation and fails in the as-is (open) position. One of the valves CC-249 and CC-250 can be closed with back up from corresponding AAC power train when containment isolation function is required.
CC-0249	E	480Vac	AE	AE	AE	The MOV is normally open in the normal operation and fails in the as-is (open) position. One of the valves CC-249 and CC-250 can be closed with back up from corresponding AAC power train when containment isolation function is required.
CV-509	E	480Vac	AE	AE	AE	The MOV is normally closed in the normal operation and fails in the as-is (closed) position. Moreover, a check valve is installed inside the containment building in series with this valve as double containment isolation barriers.
CV-523	P	125Vdc	BE	BE	BE	The valve is normally open in the normal operation and fails in the closed position.
CV-522	P	125Vdc	AE	AE	AE	The valve is normally open in the normal operation and fails in the closed position.
CV-524	E	480Vac	BE	BE	BE	This valve installed in the charging line is normally open in the normal operation and fails in the as-is (open) position. When SBO occurs, this valve maintained in open position for the RCS makeup function along with the auxiliary charging pump powered from the AAC. Moreover, a check valve is installed inside the containment building in series with this valve as double containment isolation barriers.
CV-255	E	480Vac	AE	AE	AE	This valve installed in the RCP seal injection line is normally open in the normal operation and fails in the as-is (open) position. When SBO occurs, this valve maintained in open position for the RCP seal injection function along with the auxiliary charging pump powered from the AAC. Moreover, a check valve is installed inside the containment building in series with this valve as double containment isolation barriers.

Valve No.	Actuator type ⁽¹⁾	Power	Normal Power Train	Emergency Power Train ⁽²⁾	AAC Power Train ⁽²⁾⁽³⁾	Closure for CIVs at the onset of a SBO
CV-505	P	125Vdc	BE	BE	BE	The valve is normally open in the normal operation and fails in the closed position.
CV-506	P	125Vdc	AE	AE	AE	The valve is normally open in the normal operation and fails in the closed position.
CV-561	P	125Vdc	BE	BE	BE	The valve is normally closed in the normal operation and fails in the closed position.
CV-560	P	125Vdc	AE	AE	AE	The valve is normally closed in the normal operation and fails in the closed position.
CV-580	P	125Vdc	AE	AE	AE	The valve is normally closed in the normal operation and fails in the closed position.
SA-001	P	125Vdc	AE	AE	AE	Closure is available independent of SBO because this valve is powered from station battery which is independent from AC power.
IA-020	P	125Vdc	AE	AE	AE	Closure is available independent of SBO because this valve is powered from station battery which is independent from AC power.
PX-020	S	125Vdc	AE	AE	AE	This valve is excluded from the 'appropriate containment integrity for SBO consideration', since this valve has less than 3 inch nominal diameter (RG 1.155 Section C.3.2.7).
PX-021	S	125Vdc	BE	BE	BE	This valve is excluded from the 'appropriate containment integrity for SBO consideration', since this valve has less than 3 inch nominal diameter (RG 1.155 Section C.3.2.7).
PX-0003	S	125Vdc	AE	AE	AE	This valve is excluded from the 'appropriate containment integrity for SBO consideration', since this valve has less than 3 inch nominal diameter (RG 1.155 Section C.3.2.7).
PX-0004	S	125Vdc	BE	BE	BE	This valve is excluded from the 'appropriate containment integrity for SBO consideration', since this valve has less than 3 inch nominal diameter (RG 1.155 Section C.3.2.7).

Valve No.	Actuator type ⁽¹⁾	Power	Normal Power Train	Emergency Power Train ⁽²⁾	AAC Power Train ⁽²⁾⁽³⁾	Closure for CIVs at the onset of a SBO
PX-0005	S	125Vdc	AE	AE	AE	This valve is excluded from the 'appropriate containment integrity for SBO consideration', since this valve has less than 3 inch nominal diameter (RG 1.155 Section C.3.2.7).
PX-0006	S	125Vdc	BE	BE	BE	This valve is excluded from the 'appropriate containment integrity for SBO consideration', since this valve has less than 3 inch nominal diameter (RG 1.155 Section C.3.2.7).
PX-0001	S	125Vdc	BE	BE	BE	This valve is excluded from the 'appropriate containment integrity for SBO consideration', since this valve has less than 3 inch nominal diameter (RG 1.155 Section C.3.2.7).
PX-0002	S	125Vdc	AE	AE	AE	This valve is excluded from the 'appropriate containment integrity for SBO consideration', since this valve has less than 3 inch nominal diameter (RG 1.155 Section C.3.2.7).
PS-0035	P	125Vdc	AE	AE	AE	This valve is excluded from the 'appropriate containment integrity for SBO consideration', since this valve has less than 3 inch nominal diameter (RG 1.155 Section C.3.2.7).
PS-0031	P	125Vdc	AE	AE	AE	This valve is excluded from the 'appropriate containment integrity for SBO consideration', since this valve has less than 3 inch nominal diameter (RG 1.155 Section C.3.2.7).
PS-0257	P	125Vdc	AE	AE	AE	This valve is excluded from the 'appropriate containment integrity for SBO consideration', since this valve has less than 3 inch nominal diameter (RG 1.155 Section C.3.2.7).
PS-0033	P	125Vdc	AE	AE	AE	This valve is excluded from the 'appropriate containment integrity for SBO consideration', since this valve has less than 3 inch nominal diameter (RG 1.155 Section C.3.2.7).
PS-0036	P	125Vdc	BE	BE	BE	This valve is excluded from the 'appropriate containment integrity for SBO consideration', since this valve has less than 3 inch nominal diameter (RG 1.155 Section C.3.2.7).
PS-0032	P	125Vdc	BE	BE	BE	This valve is excluded from the 'appropriate containment integrity for SBO consideration', since this valve has less than 3 inch nominal diameter (RG 1.155 Section C.3.2.7).

Valve No.	Actuator type ⁽¹⁾	Power	Normal Power Train	Emergency Power Train ⁽²⁾	AAC Power Train ⁽²⁾⁽³⁾	Closure for CIVs at the onset of a SBO
PS-0258	P	125Vdc	BE	BE	BE	This valve is excluded from the 'appropriate containment integrity for SBO consideration', since this valve has less than 3 inch nominal diameter (RG 1.155 Section C.3.2.7).
PS-0034	P	125Vdc	BE	BE	BE	This valve is excluded from the 'appropriate containment integrity for SBO consideration', since this valve has less than 3 inch nominal diameter (RG 1.155 Section C.3.2.7).
VQ-0011	EH	125Vdc	BE	BE	BE	The VQ-0011 is normally close in the normal operation and fails in the closed position.
VQ-0012	E	480Vac	AE	AE	AE	The CIV(VQ-0011) and CIV(VQ-0012) are installed in series with one outside and one inside the containment, respectively. The motor operated CIV (VQ-0012) is designed to fail as-is (open) upon loss of its power. It is noted that a electro-hydraulic operated CIV (VQ-0011) is designed to fail in closed position and is used as backup to CIV (VQ-0012). CIV (VQ-0011) is automatically closed upon loss of its power and it can provide containment isolation even if the CIV (VQ-0012) fails-as-is (open) upon loss of its power.
VQ-0013	E	480Vac	AE	AE	AE	The CIV(VQ-0013) and CIV(VQ-0014) are installed in series with one inside and one outside the containment, respectively. The motor operated CIV (VQ-0013) is designed to fail as-is (open) upon loss of its power. It is noted that a electro-hydraulic operated CIV (VQ-0014) is designed to fail in closed position and is used as backup to CIV (VQ-0013). CIV (VQ-0014) is automatically closed upon loss of its power and it can provide containment isolation even if the CIV (VQ-0013) fails-as-is (open) upon loss of its power.
VQ-0014	EH	125Vdc	BE	BE	BE	The VQ-0014 is normally close in the normal operation and fails in the closed position.
VQ-0031	P	125Vdc	BE	BE	BE	The VQ-0031 is normally close in the normal operation and fails in the closed position.
VQ-0032	P	125Vdc	AE	AE	AE	The VQ-0032 is normally close in the normal operation and fails in the closed position.

Valve No.	Actuator type ⁽¹⁾	Power	Normal Power Train	Emergency Power Train ⁽²⁾	AAC Power Train ^{(2) (3)}	Closure for CIVs at the onset of a SBO
VQ-0033	P	125Vdc	AE	AE	AE	The VQ-0033 is normally close in the normal operation and fails in the closed position.
VQ-0034	P	125Vdc	BE	BE	BE	The VQ-0034 is normally close in the normal operation and fails in the closed position.
SD-0005	P	125Vdc	AE	AE	AE	The AOV is normally open in the normal operation and fails in the closed position.
SD-0007	E	480Vac	CE	CE	NONE	The MOV is normally open in the normal operation and fails in the as-is (open) position. The valve SD-0005, located in upstream of the valve SD-0007, can be closed when containment isolation function is required.
SD-0006	P	125Vdc	BE	BE	BE	The AOV is normally open in the normal operation and fails in the closed position.
SD-0008	E	480Vac	DE	DE	NONE	The MOV is normally open in the normal operation and fails in the as-is (open) position. The valve SD-0006, located in upstream of the valve SD-0008, can be closed when containment isolation function is required.
FP-0030	P	125Vdc	AE	AE	AE	Closure is available independent of SBO because this valve is powered from station battery which is independent from AC power.
WI-0013	P	125Vdc	AE	AE	AE	The WI-0013 is normally open in the normal operation and fails in the closed position.
WI-0012	P	125Vdc	AE	AE	AE	The WI-0012 is normally open in the normal operation and fails in the closed position.
WI-0015	E	480Vac	AE	AE	AE	The CIV(WI-0015) and CIV(WI-0012) are installed in series with one inside and one outside the containment, respectively. The motor operated CIV (WI-0015) is designed to fail as-is (open) upon loss of its power. It is noted that a pneumatically operated CIV (WI-0012) is designed to fail in closed position and is used as backup to CIV (WI-0015). CIV (WI-0012) is automatically closed upon loss of its power and it can provide containment isolation even if the CIV (WI-0015) fails-as-is (open) upon loss of its power.

Valve No.	Actuator type ⁽¹⁾	Power	Normal Power Train	Emergency Power Train ⁽²⁾	AAC Power Train ⁽²⁾⁽³⁾	Closure for CIVs at the onset of a SBO
PR-432	E	480Vac	BE	BE	BE	This valve is excluded from the 'appropriate containment integrity for SBO consideration', since this valve has less than 3 inch nominal diameter (RG 1.155 Section C.3.2.7).
PR-431	E	480Vac	AE	AE	AE	This valve is excluded from the 'appropriate containment integrity for SBO consideration', since this valve has less than 3 inch nominal diameter (RG 1.155 Section C.3.2.7).
PR-434	E	480Vac	BE	BE	BE	This valve is excluded from the 'appropriate containment integrity for SBO consideration', since this valve has less than 3 inch nominal diameter (RG 1.155 Section C.3.2.7).
CM-17	S	125Vdc	AE	AE	AE	This valve is excluded from the 'appropriate containment integrity for SBO consideration', since this valve has less than 3 inch nominal diameter (RG 1.155 Section C.3.2.7).
CM-18	S	125Vdc	BE	BE	BE	This valve is excluded from the 'appropriate containment integrity for SBO consideration', since this valve has less than 3 inch nominal diameter (RG 1.155 Section C.3.2.7).
CM-19	S	125Vdc	CE	CE	NONE	This valve is excluded from the 'appropriate containment integrity for SBO consideration', since this valve has less than 3 inch nominal diameter (RG 1.155 Section C.3.2.7).
CM-20	S	125Vdc	DE	DE	NONE	This valve is excluded from the 'appropriate containment integrity for SBO consideration', since this valve has less than 3 inch nominal diameter (RG 1.155 Section C.3.2.7).
CM-21	S	125Vdc	AE	AE	AE	This valve is excluded from the 'appropriate containment integrity for SBO consideration', since this valve has less than 3 inch nominal diameter (RG 1.155 Section C.3.2.7).
CM-22	S	125Vdc	BE	BE	BE	This valve is excluded from the 'appropriate containment integrity for SBO consideration', since this valve has less than 3 inch nominal diameter (RG 1.155 Section C.3.2.7).

Valve No.	Actuator type ⁽¹⁾	Power	Normal Power Train	Emergency Power Train ⁽²⁾	AAC Power Train ⁽²⁾⁽³⁾	Closure for CIVs at the onset of a SBO
NT-0004	P	125Vdc	AE	AE	AE	Closure is available independent of SBO because this valve is powered from station battery which is independent from AC power.
PX-0041	E	480Vac	BE	BE	BE	This valve is excluded from the 'appropriate containment integrity for SBO consideration', since this valve has less than 3 inch nominal diameter (RG 1.155 Section C.3.2.7).
PX-0042	E	480Vac	AE	AE	AE	This valve is excluded from the 'appropriate containment integrity for SBO consideration', since this valve has less than 3 inch nominal diameter (RG 1.155 Section C.3.2.7).
DE-0006	P	125Vdc	AE	AE	AE	The AOV is normally open in the normal operation and fails in the closed position.
DE-0005	E	480Vac	BE	BE	BE	The MOV is normally open in the normal operation and fails in the as-is (open) position. The valve DE-0006, located in downstream of the valve DE-0005, can be closed when containment isolation function is required.
PX-0043	E	480Vac	BE	BE	BE	This valve is excluded from the 'appropriate containment integrity for SBO consideration', since this valve has less than 3 inch nominal diameter (RG 1.155 Section C.3.2.7).
GW-0002	S	125Vdc	BE	BE	BE	This valve is excluded from the 'appropriate containment integrity for SBO consideration', since this valve has less than 3 inch nominal diameter (RG 1.155 Section C.3.2.7).
GW-0001	E	480Vac	AE	AE	AE	This valve is excluded from the 'appropriate containment integrity for SBO consideration', since this valve has less than 3 inch nominal diameter (RG 1.155 Section C.3.2.7).
PX-0053	S	125Vdc	AE	AE	AE	This valve is excluded from the 'appropriate containment integrity for SBO consideration', since this valve has less than 3 inch nominal diameter (RG 1.155 Section C.3.2.7).
CA-0013	E	480Vac	BE	BE	BE	The MOV is normally closed in the normal operation and fails in the as-is (closed) position.

Valve No.	Actuator type ⁽¹⁾	Power	Normal Power Train	Emergency Power Train ⁽²⁾	AAC Power Train ⁽²⁾⁽³⁾	Closure for CIVs at the onset of a SBO
CM-001	S	125Vdc	AE	AE	AE	This valve is excluded from the 'appropriate containment integrity for SBO consideration', since this valve has less than 3 inch nominal diameter (RG 1.155 Section C.3.2.7).
CM-003	S	125Vdc	AE	AE	AE	This valve is excluded from the 'appropriate containment integrity for SBO consideration', since this valve has less than 3 inch nominal diameter (RG 1.155 Section C.3.2.7).
CM-023	S	125Vdc	AE	AE	AE	This valve is excluded from the 'appropriate containment integrity for SBO consideration', since this valve has less than 3 inch nominal diameter (RG 1.155 Section C.3.2.7).
CM-009	S	125Vdc	AE	AE	AE	This valve is excluded from the 'appropriate containment integrity for SBO consideration', since this valve has less than 3 inch nominal diameter (RG 1.155 Section C.3.2.7).
CM-002	S	125Vdc	BE	BE	BE	This valve is excluded from the 'appropriate containment integrity for SBO consideration', since this valve has less than 3 inch nominal diameter (RG 1.155 Section C.3.2.7).
CM-004	S	125Vdc	BE	BE	BE	This valve is excluded from the 'appropriate containment integrity for SBO consideration', since this valve has less than 3 inch nominal diameter (RG 1.155 Section C.3.2.7).
CM-024	S	125Vdc	BE	BE	BE	This valve is excluded from the 'appropriate containment integrity for SBO consideration', since this valve has less than 3 inch nominal diameter (RG 1.155 Section C.3.2.7).
CM-011	S	125Vdc	AE	AE	AE	This valve is excluded from the 'appropriate containment integrity for SBO consideration', since this valve has less than 3 inch nominal diameter (RG 1.155 Section C.3.2.7).
CM-013	S	125Vdc	AE	AE	AE	This valve is excluded from the 'appropriate containment integrity for SBO consideration', since this valve has less than 3 inch nominal diameter (RG 1.155 Section C.3.2.7).

Valve No.	Actuator type ⁽¹⁾	Power	Normal Power Train	Emergency Power Train ⁽²⁾	AAC Power Train ⁽²⁾⁽³⁾	Closure for CIVs at the onset of a SBO
CM-012	S	125Vdc	BE	BE	BE	This valve is excluded from the 'appropriate containment integrity for SBO consideration', since this valve has less than 3 inch nominal diameter (RG 1.155 Section C.3.2.7).
CM-014	S	125Vdc	BE	BE	BE	This valve is excluded from the 'appropriate containment integrity for SBO consideration', since this valve has less than 3 inch nominal diameter (RG 1.155 Section C.3.2.7).
IW-005	E	480Vac	AE	AE	AE	The MOV is normally closed in the normal operation and fails in the as-is (closed) position.
IW-006	E	480Vac	BE	BE	BE	The MOV is normally closed in the normal operation and fails in the as-is (closed) position.
IW-010	S	125Vdc	BE	BE	BE	This valve is excluded from the 'appropriate containment integrity for SBO consideration', since this valve has less than 3 inch nominal diameter (RG 1.155 Section C.3.2.7).
IW-022	S	125Vdc	AE	AE	AE	This valve is excluded from the 'appropriate containment integrity for SBO consideration', since this valve has less than 3 inch nominal diameter (RG 1.155 Section C.3.2.7).
IW-024	S	125Vdc	CE	CE	NONE	This valve is excluded from the 'appropriate containment integrity for SBO consideration', since this valve has less than 3 inch nominal diameter (RG 1.155 Section C.3.2.7).
IW-026	S	125Vdc	DE	DE	NONE	This valve is excluded from the 'appropriate containment integrity for SBO consideration', since this valve has less than 3 inch nominal diameter (RG 1.155 Section C.3.2.7).
IW-011	S	125Vdc	BE	BE	BE	This valve is excluded from the 'appropriate containment integrity for SBO consideration', since this valve has less than 3 inch nominal diameter (RG 1.155 Section C.3.2.7).

Valve No.	Actuator type ⁽¹⁾	Power	Normal Power Train	Emergency Power Train ⁽²⁾	AAC Power Train ⁽²⁾⁽³⁾	Closure for CIVs at the onset of a SBO
IW-023	S	125Vdc	AE	AE	AE	This valve is excluded from the 'appropriate containment integrity for SBO consideration', since this valve has less than 3 inch nominal diameter (RG 1.155 Section C.3.2.7).
IW-025	S	125Vdc	CE	CE	NONE	This valve is excluded from the 'appropriate containment integrity for SBO consideration', since this valve has less than 3 inch nominal diameter (RG 1.155 Section C.3.2.7).
IW-027	S	125Vdc	DE	DE	NONE	This valve is excluded from the 'appropriate containment integrity for SBO consideration', since this valve has less than 3 inch nominal diameter (RG 1.155 Section C.3.2.7).
IW-012	S	125Vdc	AE	AE	AE	This valve is excluded from the 'appropriate containment integrity for SBO consideration', since this valve has less than 3 inch nominal diameter (RG 1.155 Section C.3.2.7).
IW-013	S	125Vdc	AE	AE	AE	This valve is excluded from the 'appropriate containment integrity for SBO consideration', since this valve has less than 3 inch nominal diameter (RG 1.155 Section C.3.2.7).
IW-014	S	125Vdc	BE	BE	BE	This valve is excluded from the 'appropriate containment integrity for SBO consideration', since this valve has less than 3 inch nominal diameter (RG 1.155 Section C.3.2.7).
IW-015	S	125Vdc	BE	BE	BE	This valve is excluded from the 'appropriate containment integrity for SBO consideration', since this valve has less than 3 inch nominal diameter (RG 1.155 Section C.3.2.7).
IW-016	S	125Vdc	AE	AE	AE	This valve is excluded from the 'appropriate containment integrity for SBO consideration', since this valve has less than 3 inch nominal diameter (RG 1.155 Section C.3.2.7).
IW-017	S	125Vdc	AE	AE	AE	This valve is excluded from the 'appropriate containment integrity for SBO consideration', since this valve has less than 3 inch nominal diameter (RG 1.155 Section C.3.2.7).

Valve No.	Actuator type ⁽¹⁾	Power	Normal Power Train	Emergency Power Train ⁽²⁾	AAC Power Train ^{(2) (3)}	Closure for CIVs at the onset of a SBO
IW-028	S	125Vdc	CE	CE	NONE	This valve is excluded from the 'appropriate containment integrity for SBO consideration', since this valve has less than 3 inch nominal diameter (RG 1.155 Section C.3.2.7).
IW-029	S	125Vdc	CE	CE	NONE	This valve is excluded from the 'appropriate containment integrity for SBO consideration', since this valve has less than 3 inch nominal diameter (RG 1.155 Section C.3.2.7).
IW-030	S	125Vdc	DE	DE	NONE	This valve is excluded from the 'appropriate containment integrity for SBO consideration', since this valve has less than 3 inch nominal diameter (RG 1.155 Section C.3.2.7).
IW-031	S	125Vdc	DE	DE	NONE	This valve is excluded from the 'appropriate containment integrity for SBO consideration', since this valve has less than 3 inch nominal diameter (RG 1.155 Section C.3.2.7).
IW-018	S	125Vdc	AE	AE	AE	This valve is excluded from the 'appropriate containment integrity for SBO consideration', since this valve has less than 3 inch nominal diameter (RG 1.155 Section C.3.2.7).
IW-019	S	125Vdc	AE	AE	AE	This valve is excluded from the 'appropriate containment integrity for SBO consideration', since this valve has less than 3 inch nominal diameter (RG 1.155 Section C.3.2.7).
IW-020	S	125Vdc	BE	BE	BE	This valve is excluded from the 'appropriate containment integrity for SBO consideration', since this valve has less than 3 inch nominal diameter (RG 1.155 Section C.3.2.7).
IW-021	S	125Vdc	BE	BE	BE	This valve is excluded from the 'appropriate containment integrity for SBO consideration', since this valve has less than 3 inch nominal diameter (RG 1.155 Section C.3.2.7).
IW-032	S	125Vdc	CE	CE	NONE	This valve is excluded from the 'appropriate containment integrity for SBO consideration', since this valve has less than 3 inch nominal diameter (RG 1.155 Section C.3.2.7).

Valve No.	Actuator type ⁽¹⁾	Power	Normal Power Train	Emergency Power Train ⁽²⁾	AAC Power Train ⁽²⁾⁽³⁾	Closure for CIVs at the onset of a SBO
IW-033	S	125Vdc	CE	CE	NONE	This valve is excluded from the 'appropriate containment integrity for SBO consideration', since this valve has less than 3 inch nominal diameter (RG 1.155 Section C.3.2.7).
IW-034	S	125Vdc	DE	DE	NONE	This valve is excluded from the 'appropriate containment integrity for SBO consideration', since this valve has less than 3 inch nominal diameter (RG 1.155 Section C.3.2.7).
IW-035	S	125Vdc	DE	DE	NONE	This valve is excluded from the 'appropriate containment integrity for SBO consideration', since this valve has less than 3 inch nominal diameter (RG 1.155 Section C.3.2.7).

NOTES

(1) Actuator Type Abbreviations

- E : Motor Operated (Electric Powered)
- P : Pneumatically Operated
- S : Solenoid Operator
- EH : Electro Hydraulic Operated

(2) SBO coping duration for the APR 1400 is 16 hours. During an SBO, availability of the Class 1E 120Vdc and 120Vac instrumentation and control power is as follows:

- Train A and B : 8 hour or 16 hour (note: 16 hour duty cycle is available for the train to which the AAC source is aligned)
- Train C and D : 16 hour

(3) AAC source is available for either one of Train A or Train B.

Impact on DCD

DCD Tier 2, Subsections 6.2.4.1.2, Table 9.2.2-6, and Figure 9.2.2-1 will be revised, as indicated in the Attachment associated with this response.

Impact on PRA

There is no impact on the PRA.

Impact on Technical Specifications

There is no impact on the Technical Specifications.

Impact on Technical/Topical/Environmental Reports

There is no impact on any Technical, Topical, or Environmental Report.

APR1400 DCD TIER 2

- h. Valve operators and power sources are selected for containment isolation valves consistent with their required safety function.
- i. Instrumentation and control sensing lines that penetrate the containment are provided with containment isolation provisions, which meets the intent of NRC RG 1.11.
- j. All containment penetrations not used for accident mitigation or safe shutdown are automatically isolated by a CIAS unless:
 - 1) The valves are normally locked closed.
 - 2) The penetrations are normally sealed (e.g., fuel transfer tube).
 - 3) The lines are needed for RCP operation (RCP seal injection and component cooling water to RCP seal coolers, motors, and lube oil coolers).

The exception of the lines for RCP operation allows the RCPs to be available for accident mitigation or safe shutdown if offsite power and non-essential support systems are available. These lines are continuously monitored for radiation and can be manually isolated from the MCR.

- k. The induced stresses in the pressure retaining components of the CIVs, due to an internal containment pressure of less than or equal to 7.67 kg/cm^2 (109 psig), are within the ASME Section III Factored Load Category.

6.2.4.2 System Design

No single flow diagram shows all of the containment penetrations, but they are shown on appropriate flow diagram for systems. Containment isolation provisions are tabulated in Table 6.2.4-1. The appropriate valve arrangements are illustrated in Figure 6.2.4-1.

All valves that receive an ESFAS are designed and tested with closing time appropriate to the function performed. The sequencing system for loading the onsite emergency

I. Open/close position indication for all power operated CIVs is provided in the MCR. The position indication and containment isolation function are available during a station black out.

APR1400 DCD TIER 2

Table 9.2.2-6 (2 of 3)

CCWS Motor-Operated Valves (Cont'd)	
Valve	Train
CC-V-0143	A
CC-V-0144	B
CC-V-0145	C
CC-V-0146	D
CC-V-0147	C
CC-V-0148	D
CC-V-0149	A
CC-V-0150	B
CC-V-0181	C
CC-V-0182	D
CC-V-0191	A
CC-V-0192	B
CC-V-0231	€ ← A
CC-V-0249	A ← B
CC-V-0250	€ ← A
CC-V-0296	A
CC-V-0297	B
CC-V-0301	B
CC-V-0302	A
CC-V-0351	A
CC-V-0352	B
CC-V-0383	A
CC-V-0384	B
CC-V-0389	A
CC-V-0390	B
CC-V-0937	A
CC-V-0938	B
CC-V-0939	C
CC-V-0940	D

APR1400 DCD TIER 2

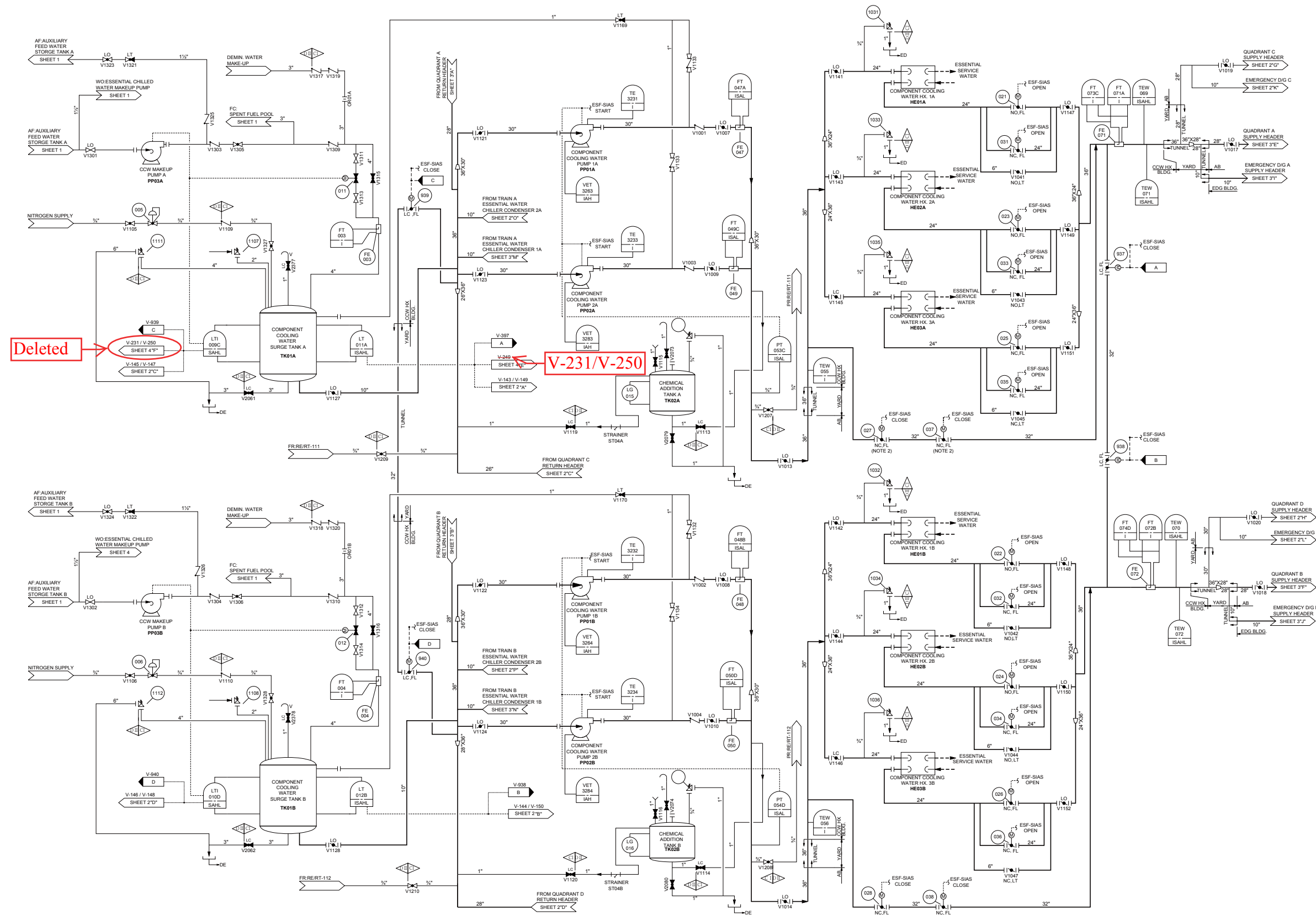

Figure 9.2.2-1 Component Cooling Water System Flow Diagram (1 of 4)

APR1400 DCD TIER 2

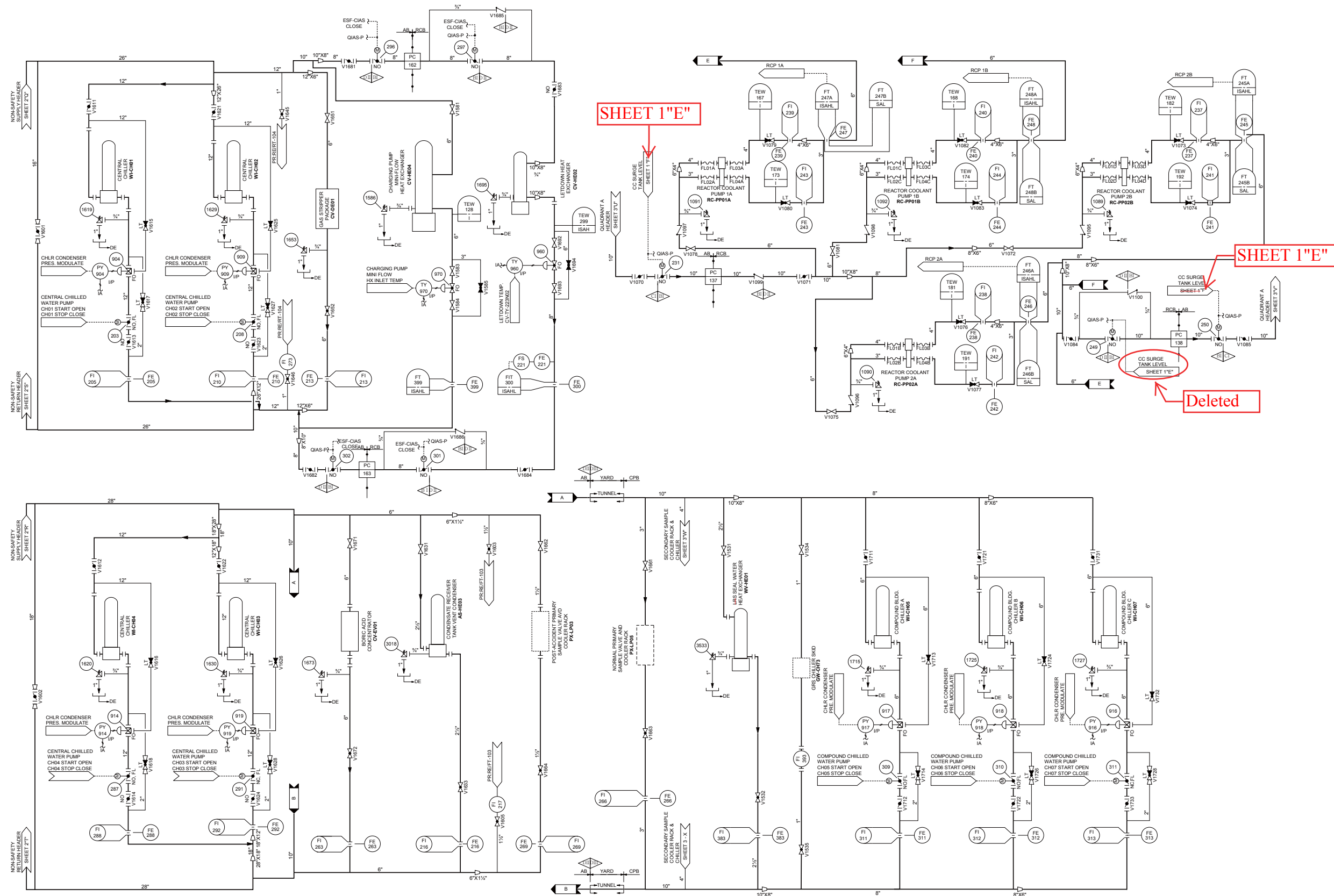

Figure 9.2.2-1 Component Cooling Water System Flow Diagram (4 of 4)