

NORTH & SOUTH ELEVATIONS

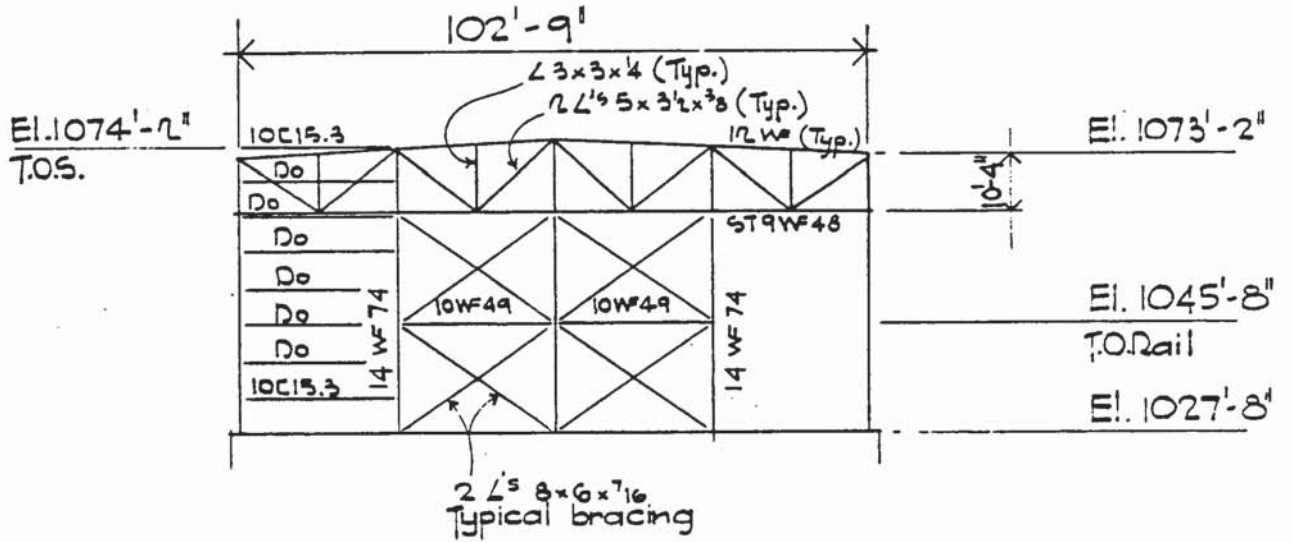

EAST & WEST ELEVATIONS

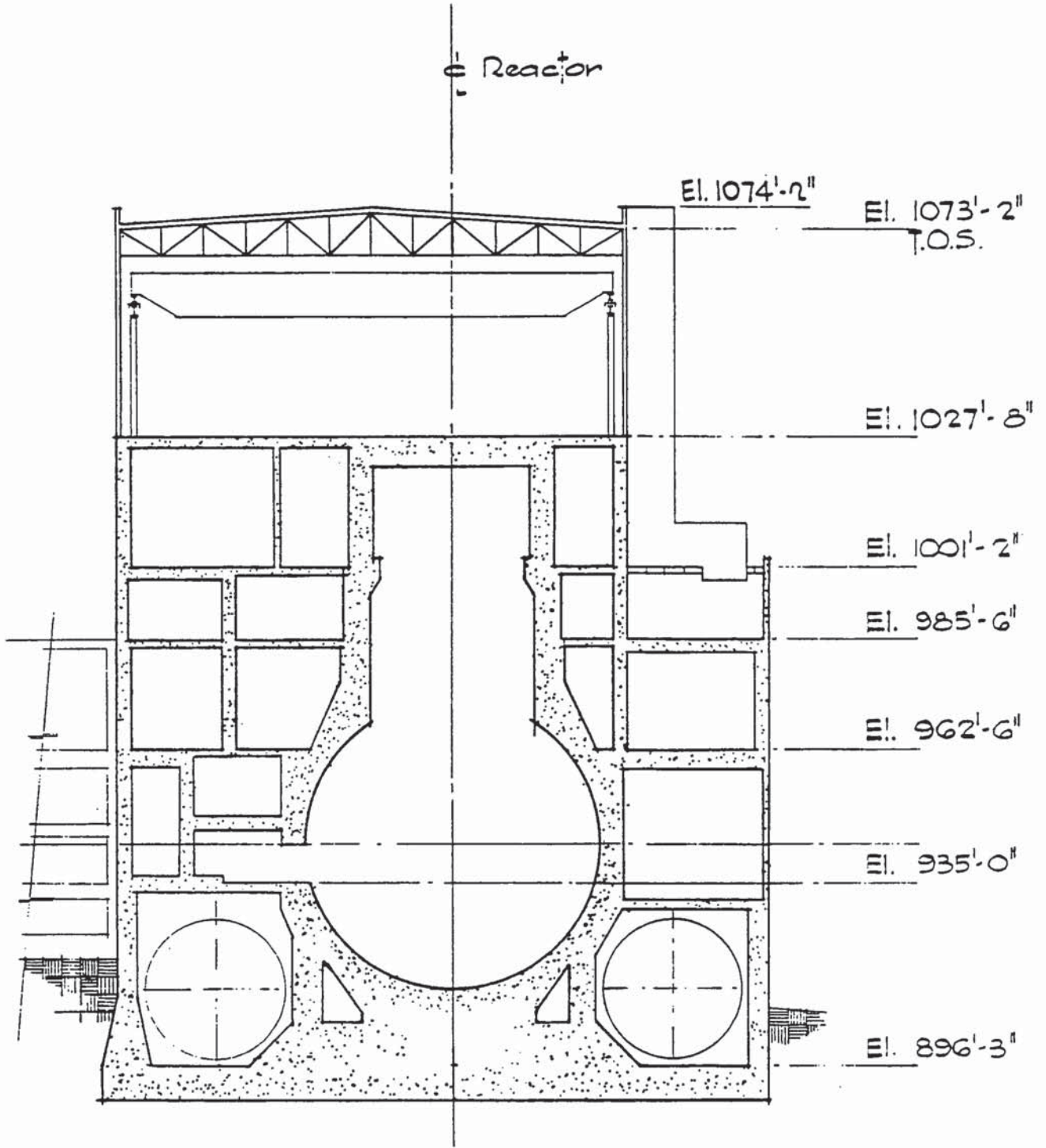

TRANSVERSE SECTION

SHEET NO. 18

JOHN A. BLUME AND ASSOCIATES, ENGINEERS
MONTICELLO REACTOR BUILDING
SEISMIC ANALYSIS

LUMPED WEIGHTS

WEIGHT 1 (@EL. 1073'-2")

$$\text{ROOF} = 18 \text{ PSF}$$

$$= 0.018 \times 137.5 \times 105.3 = 260.62 \text{ K}$$

$$\text{WALLS} = 12 \text{ PSF}$$

$$= 0.012 \times (137.5 + 105.3) \times 14.9 \times 2 = 86.82$$

$$\frac{1}{2} \text{ BRIDGE CRANE} = \frac{1}{2} \times (200 + 57) = 128.50$$

$$\begin{aligned} \frac{1}{2} \text{ CRANE RAIL} &= \frac{1}{2} \times 134.5 \times 2 \times \\ &\times \left(\frac{0.100}{3} + 0.194 + 0.058 \right) = 38.33 \end{aligned}$$

$$\text{SNOW LOAD} = 15 \text{ PSF}$$

$$= 0.015 \times (137.5 \times 105.3) = 217.13$$

$$\text{VENT STACK} = 13.75 \times \frac{24}{72} = \underline{4.58}$$

$$\underline{\underline{\text{WEIGHT 1} = 735.98 \text{ K}}}$$

WEIGHT 2 (@EL. 1045'-8")

$$\text{WALLS} = 12 \text{ PSF}$$

$$= 0.012 \times (137.5 + 105.3) \times 22.75 \times 2 = 132.56 \text{ K}$$

$$\text{VENT STACK} = 22.75 \times \frac{24}{72} = \underline{7.58}$$

$$\underline{\underline{\text{WEIGHT 2} = 140.14 \text{ K}}}$$

JOHN A. BLUME AND ASSOCIATES, ENGINEERS
MONTICELLO REACTOR BUILDING
SEISMIC ANALYSIS

WEIGHT 3 (@ EL. 1027'-8")

VOLUME OF CONCRETE:

WALLS & COLUMNS BELOW:

$$\frac{1}{2} \times 26.50 \times 2,255.58 = 29,886.44 \text{ ft.}^3$$

SLABS @ EL. 1027'-8":

$$6.00 \times 820.49 = 4,922.94$$

$$2.00 \times 9,090.11 = 18,180.22$$

BEAMS:

$$3.00 \times 6.00 \times 256.75 = 4,621.50$$

$$3.00 \times 7.00 \times 114.00 = 2,394.00$$

$$3.00 \times 5.00 \times 90.75 = 1,361.25$$

$$2.00 \times 4.00 \times 10.00 = 800.00$$

SHIELD:

$$22.25 \times 40.86 = \underline{909.14}$$

$$\text{TOTAL VOLUME OF CONCRETE} = 63,075.49 \text{ ft.}^3$$

JOHN A. BLUME AND ASSOCIATES, ENGINEERS
MONTICELLO REACTOR BUILDING
SEISMIC ANALYSIS

WEIGHT 3 (CONT.)

TOTAL WEIGHT OF CONCRETE	$= 0.15 \times 63,075.49$	$= 9,461.32 K$
WALLS ABOVE	$= 0.012 \times (137.5 + 105.3) \times 9 \times 2$	$= 52.44$
1/2 BRIDGE CRANE		$= 128.50$
1/2 CRANE RAIL		$= 38.33$
CRANE COLUMNS	$= 14 \times 0.074 \times 25.25$	$= 26.16$
VENT STACK	$= 22.25 \times \frac{24}{72}$	$= 7.42$
1/10 DRYWELL		$= 120.00$
1/5 HOIST & SUPPORT STEEL (ASSUMED)		$= 4.00$
1/5 VENTILATION EQUIPMENT (ASSUMED)		$= 20.00$
LINER, POOLS & REACTOR WELL		$= 135.00$
1/10 ELEVATOR (ASSUMED)		$= 42.00$
1/5 MISC. ELECT. EQUIPMENT		$= 50.00$
1/5 MISC. PIPING		$= 50.00$
STUD TENSIONERS		$= 16.00$
JIB CRANE		$= 3.00$
MISC. LIFTING SLINGS		$= 14.00$
SHIELDING PLUG OVER VESSEL (6 PCS.)		$= 240.00$
REFUELING BRIDGE & SERV. PLATFORM		$= 50.00$
1/3 WATER IN FUEL STORAGE POOL		$= 822.00$
WATER-DRYER & SEPARATOR POOL		$= 638.00$
NEW FUEL STORAGE VAULT		
	$(1.5 \times 6 \times 7)$	$= 168.00$
		<u>WEIGHT 3 = 12,786.17K</u>

JOHN A. BLUME AND ASSOCIATES, ENGINEERS
MONTICELLO REACTOR BUILDING
SEISMIC ANALYSIS

WEIGHT 4 (@ EL. 1001'-2")

VOLUME OF CONCRETE :

WALLS & COLUMNS ABOVE :

$$\frac{1}{2} \times 26.50 \times 2,255.58 = 29,886.44 \text{ ft.}^3$$

WALLS & COLUMNS BELOW :

$$\frac{1}{2} \times 15.67 \times 3,393.69 = 26,589.59$$

SLABS @ EL. 1001'-2" :

$$4.00 \times 198.00 = 792.00$$

$$2.50 \times 220.00 = 550.00$$

$$2.00 \times 840.00 = 1,680.00$$

$$1.00 \times 8,071.19 = 8,071.19$$

$$2.00 \times 210.00 = 420.00$$

BEAMS :

$$2.00 \times 4.00 \times 235.50 = 1,884.00$$

SHIELD :

$$21.08 \times 40.86 = \underline{861.33}$$

TOTAL VOLUME OF CONCRETE = 70,734.55 ft.³

JOHN A. BLUME AND ASSOCIATES, ENGINEERS
MONTICELLO REACTOR BUILDING
SEISMIC ANALYSIS

WEIGHT 4 (CONT.)

TOTAL WEIGHT OF CONCRETE = $0.15 \times 70,734.55$	= 10,610.18 K
VENT STACK = $13.25 \times \frac{24}{72}$	= 4.42
DECK ROOF = $0.005 \times (32.25 \times 113.50)$	= 18.30
1/5 DRYWELL	= 240.00
1/5 HOIST & SUPPORT STEEL (ASSUMED)	= 4.00
1/5 VENTILATION EQUIPMENT (ASSUMED)	= 20.00
1/5 R.P.V. WATER & FUEL	= 600.00
1/5 ELEVATOR (ASSUMED)	= 84.00
1/5 MISC. ELECT. EQUIPMENT	= 50.00
1/5 MISC. PIPING	= 50.00
SKIMMER SURGE TANKS	= 24.00
STEAM DRYER	= 51.00
STEAM SEPARATOR	= 37.00
1/2 WATER IN FUEL STORAGE POOL	= 1,233.00
1/2 WATER-DRYER & SEPARATOR POOL	= 633.00
STAND-BY LIQUID CONTROL SYSTEM TANK	= 26.00
STAND-BY LIQUID CONTROL SYSTEM PUMPS	= 6.00
STAND-BY LIQUID CONTROL SYSTEM TEST TANK	= 2.00
HOLD UP PUMPS	= 1.00

WEIGHT 4 = 13,748.90 K

SHEET NO. 23

JOHN A. BLUME AND ASSOCIATES, ENGINEERS
MONTICELLO REACTOR BUILDING
SEISMIC ANALYSIS

WEIGHT 5 (@ EL. 985'-6")

VOLUME OF CONCRETE :

WALLS & COLUMNS ABOVE :

$$\frac{1}{2} \times 15.67 \times 3,365.19 = 26,363.26 \text{ ft}^3$$

WALLS & COLUMNS BELOW :

$$\frac{1}{2} \times 23.00 \times 2,834.69 = 32,598.94$$

SLABS @ EL. 985'-6" :

$$4.00 \times 598.00 = 2,396.00$$

$$3.00 \times 880.00 = 2,640.00$$

$$2.00 \times 635.50 = 1,307.00$$

$$1.50 \times 2,109.42 = 3,164.13$$

$$5.50 \times 1,040.00 = 5,720.00$$

$$1.00 \times 9,665.19 = 9,665.19$$

BEAMS :

$$2.50 \times 6.00 \times 61.00 = 915.00$$

$$3.00 \times 6.00 \times 64.50 = 1,161.00$$

$$3.00 \times 8.00 \times 66.75 = 1,602.00$$

$$2.00 \times 4.00 \times 55.13 = 441.00$$

$$3.00 \times 7.00 \times 48.00 = 1,008.00$$

SHIELD :

$$19.33 \times 40.86 = \underline{789.82}$$

$$\text{TOTAL VOLUME OF CONCRETE} = 89,770.54 \text{ ft}^3$$

JOHN A. BLUME AND ASSOCIATES, ENGINEERS
MONTICELLO REACTOR BUILDING
SEISMIC ANALYSIS

WEIGHT 5 (CONT.)

TOTAL WEIGHT OF CONCRETE	=	$0.15 \times 89,770.34$	=	13,465.55 K
MASONRY WALLS	=	$0.15 \times 1,391.53$	=	208.73
1/5 DRYWELL	=		=	240.00
1/5 HOIST & SUPPORT STEEL (ASSUMED)	=		=	4.00
1/5 VENTILATION EQUIPMENT	=		=	20.00
2/5 R.P.V. WATER & FUEL	=		=	1,200.00
1/5 ELEVATOR (ASSUMED)	=		=	84.00
1/5 MISC. ELECT. EQUIPMENT	=		=	50.00
1/5 MISC. PIPING	=		=	50.00
SHIPPING CASK	=		=	150.00
1/6 WATER IN FUEL STORAGE POOL	=		=	411.00
FUEL & EQUIPMENT IN POOL				
(4.4 x 40 x 26 - 2465)	=		=	2,115.00
FUEL POOL COOLING HEAT EXCH. & PUMPS	=		=	36.00
FILTERS	=		=	42.00
COOLING WATER HEAT EXCHANGER	=		=	120.00
COOLING WATER PUMPS	=		=	42.00
COOLING WATER SURGE TANK	=		=	26.00
COLLECTOR TANKS	=		=	282.00
CHEMICAL WASTE TANK	=		=	40.00
				<u>18,586.28 K</u>

JOHN A. BLUME AND ASSOCIATES, ENGINEERS
MONTICELLO REACTOR BUILDING
SEISMIC ANALYSIS

WEIGHT G (@ EL. 962'-6")

VOLUME OF CONCRETE:

WALLS & COLUMNS ABOVE:

$$\frac{1}{2} \times 3.14 \times 11.5 \times [8 \times (6 \times 46) + (44 \times 60) - (32 \times 48)] = 9,966.36 \text{ ft}^3$$

$$\frac{1}{2} \times 23.00 \times 2,050.63 = 23,582.24$$

$$9.50 \times 2.50 \times 18 = 427.50$$

WALLS & COLUMNS BELOW:

$$\left(\frac{1}{4} \times 3.14 \times 70^2 \times 13.75 \right)$$

$$- \frac{1}{2} \times 3.14 \times 13.75 [48^2 + 60^2 + (48 \times 60)] = 21,285.27$$

$$\frac{1}{2} \times 27.50 \times 1,741.27 = 23,942.50$$

SLABS @ EL. 962'-6":

$$4.00 \times 720.00 = 2,880.00$$

$$2.00 \times 1,056.00 = 2,112.00$$

$$2.50 \times 1,877.00 = 4,692.50$$

$$3.50 \times 426.14 = 1,491.49$$

$$3.00 \times 500.00 = 1,500.00$$

$$1.00 \times 8,105.25 = 8,105.25$$

SLAB @ EL. 972'-0":

$$2.50 \times 101.50 = 253.75$$

JOHN A. BLUME AND ASSOCIATES, ENGINEERS
MONTICELLO REACTOR BUILDING
SEISMIC ANALYSIS

WEIGHT G (CONT.)

BEAMS:

3.00 x 6.00 x 77.25	=	1,390.50 ft. ³
2.00 x 6.00 x 32.00	=	384.00
3.00 x 8.00 x 90.75	=	2,178.00
2.00 x 5.00 x 196.75	=	1,967.50
3.00 x 7.00 x 88.75	=	1,863.75
3.50 x 8.00 x 36.00	=	1,008.00
2.00 x 4.00 x 45.25	=	362.00
3.50 x 6.50 x 38.00	=	864.50
4.50 x 8.25 x 30.00	=	1,113.60
3.00 x 5.00 x 44.50	=	667.50
3.00 x 5.50 x 42.00	=	693.00

SHIELD:

25.25 x 40.86	=	<u>1,031.72</u>
---------------	---	-----------------

TOTAL VOLUME OF CONCRETE	=	113,762.93 ft. ³
--------------------------	---	-----------------------------

JOHN A. BLUME AND ASSOCIATES, ENGINEERS
MONTICELLO REACTOR BUILDING
SEISMIC ANALYSIS
WEIGHT G (CONT.)

TOTAL WEIGHT OF CONCRETE = $0.15 \times 113,762.93$	17,064.44 K
MASONRY WALLS = 0.15×1581.53	247.23
STEEL FLOOR FRAMING = 0.02×3216.00	64.32
1/4 DRYWELL	300.00
1/2 RECIRCULATION PIPING, WATER, VALVES & PUMPS	224.00
1/5 HOIST & SUPPORT STEEL (ASSUMED)	4.00
1/5 VENTILATION EQUIPMENT (ASSUMED)	20.00
2/5 R.P.V. WATER & FUEL	1,200.00
1/4 ELEVATOR (ASSUMED)	105.00
MOTOR GENERATORS	200.00
1/5 MISC. ELECT. EQUIPMENT	50.00
1/5 MISC. PIPING	50.00
SLUDGE STORAGE TANKS	140.00
DECANTE PIPES	1.00
WASTE SLUDGE TANK	92.00
CONDENSATE SLUDGE TANK	321.00
SLUDGE RECEIVER TANKS	60.00
NON-REGEN. HEAT EXCHANGER	57.00
REGEN. HEAT EXCHANGER	38.00
RECIRCULATION SURGE TANK	5.00
RECIRCULATION PUMPS	64.00
	<hr/>
<u>WEIGHT G</u>	<u>20,306.99 K</u>

JOHN A. BLUME AND ASSOCIATES, ENGINEERS
MONTICELLO REACTOR BUILDING
SEISMIC ANALYSIS

WEIGHT 7 (@ EL. 935'-0")

VOLUME OF CONCRETE:

WALLS & COLUMNS ABOVE:

$$\frac{1}{2} \times 27.50 \times 1,532.55 = 21,072.50 \text{ ft}^3$$

$$13.00 \times 202.00 = 2,626.00$$

WALLS & COLUMNS BELOW:

$$\left(\frac{1}{4} \times 3.14 \times 66^2 \times 19.37\right)$$

$$- \left[\frac{1}{3} \times 3.14 \times 19.37^2 \times (3 \times 31 - 19.37)\right]$$

$$+ \left(\frac{1}{4} \times 3.14 \times 40^2 \times 5\right)$$

$$- \left[\frac{1}{2} (3 \times 2) \times 3.14 \times 52\right] = 43,110.23$$

$$(3 \times 7) \times 3.14 \times 68 = 4,483.92$$

$$19.37 \times (134.00 \times 3.5) \times 4 = 36,338.12$$

$$3.50 \times 17.38 \times [(2 \times 28) + 57] = 6,873.79$$

SLABS @ EL. 935'-0":

$$2.50 \times 3,238.50 = 8,096.25$$

$$3.00 \times 6,020.24 = 18,060.72$$

$$2.00 \times 6,233.35 = 12,466.70$$

SHIELD:

$$27.00 \times 263.76 = \underline{7,121.52}$$

$$\text{TOTAL VOLUME OF CONCRETE} = 160,249.75 \text{ ft}^3$$

JOHN A. BLUME AND ASSOCIATES, ENGINEERS
MONTICELLO REACTOR BUILDING
SEISMIC ANALYSIS

WEIGHT 7 (CONT.)

TOTAL WEIGHT OF CONCRETE	=	$0.15 \times 160,249.75$	=	24,037.46 K
MASONRY WALLS	=	$0.15 \times 8,044.17$	=	1,206.63
1/3 DRYWELL	=		=	400.00
1/2 SUPPRESSION CHAMBER & VENTS	=		=	850.00
1/2 WATER IN SUPPRESSION CHAMBER	=		=	2,357.00
1/2 RECIRCULATION PIPING, WATER, VALVE & PUMPS.	=		=	224.00
1/5 HOIST & SUPPORT STEEL (ASSUMED)	=		=	4.00
1/5 VENTILATION EQUIPMENT (ASSUMED)	=		=	20.00
ISOLATION VALVES	=		=	100.00
CORE SPRAY PUMPS	=		=	20.00
REACTOR EQUIPT, DRAIN TANK & PUMP	=		=	47.00
FLUX MONITOR EQUIPMENT	=		=	10.00
GAMMA MONITORING	=		=	25.00
INSTRUMENTS & AIR LINES	=		=	25.00
1/4 ELEVATOR (ASSUMED)	=		=	105.00
SHUT-DOWN HEAT EXCHANGER	=		=	60.00
SHUT-DOWN PUMPS	=		=	60.00
1/5 MISC. ELECT. EQUIPMENT	=		=	50.00
1/5 MISC. PIPING	=		=	50.00
CONTROL ROD DRIVE EQUIPMENT	=		=	121.00
				<u>WEIGHT 7 = 29,782.09 K</u>

JOHN A. BLUME AND ASSOCIATES, ENGINEERS
MONTICELLO REACTOR BUILDING
SEISMIC ANALYSIS

WEIGHT 8 (@ EL. 896' - 3")

VOLUME OF CONCRETE :

$$\left(\frac{1}{4} \times 3.14 \times 66^2 \times 10\right) - \left[(5.25 \times 8) + (8 \times 2)\right] \times (15 \times 8) = 27,603.55 \text{ ft}^3$$

$$\frac{1}{2} \times 3.14 \times 9 \left[66^2 + 84^2 + (66 \times 84)\right] - (24 \times 9 \times 8) = 38,203.38$$

$$8 \times \left[(140.5 \times 140.5) + (3 \times 83) + (24 \times 9)\right] = 161,642.00$$

$$19.37 \times (134.00 \times 3.50) \times 4.00 = 36,333.12$$

$$\left[(25 \times 3) + (40 \times 3)\right] \times \frac{14}{3} = 910.00$$

$$19.37 \times (52 \times 3) \times 4 = 12,086.88$$

$$19.37 \times 3.5 \times \left[(2 \times 28) + 57\right] + (8 \times 3.14 \times 57) = \underline{22,024.34}$$

$$\text{TOTAL VOLUME OF CONCRETE} = 298,810.77 \text{ ft}^3$$

$$\text{TOTAL WEIGHT OF CONCRETE} = 0.15 \times 298,810.77 = 44,821.62 \text{ K}$$

$$\frac{1}{2} \text{ SUPPRESSION CHAMBER \& VENTS} = 850.00$$

$$\frac{1}{2} \text{ WATER IN SUPPRESSION CHAMBER} = \underline{2,367.00}$$

$$\underline{\underline{\text{WEIGHT 8} = 48,038.62 \text{ K}}}$$

JOHN A. BLUME AND ASSOCIATES, ENGINEERS
MONTICELLO REACTOR BUILDING
SEISMIC ANALYSIS

SECTION PROPERTIES

a. EARTHQUAKE IN N-S DIRECTION (E-W AXIS)
 EL. 1027'-0" TO EL. 1001'-2"

b ft.	d ft.	L ft.	A = bd ft. ²	$I_o = \frac{1}{12} Ad^2$ ft. ⁴	AL ² ft. ⁴
2x1.00	105.25	16.13	210.50	194,318.86	54,765.79
1.00	24.00	0.00	24.00	1,152.00	0
6.00	14.00	18.00	84.00	1,372.00	27,216.00
6.00	14.00	18.00	84.00	1,372.00	27,216.00
5.00	50.50	0.25	252.50	53,661.51	15.15
1.00	15.00	28.50	15.00	281.25	12,183.75
1.00	13.00	30.00	13.00	183.08	11,700.00
135.50	1.00	36.00	135.50	11.29	175,608.00
135.50	1.00	68.25	135.50	11.29	631,167.13
26.00	5.50	22.75	143.00	360.47	74,011.08
26.00	5.00	22.50	130.00	270.83	65,812.50
2x47.00	2.50	10.75	235.00	122.39	27,156.60
11.00	2.00	24.50	22.00	7.33	13,205.50
57.50	1.00	35.50	57.50	4.79	72,464.38
9.00	1.00	57.50	9.00	0.75	29,756.25
2x2.00	1.50	34.75	6.00	1.12	7,243.36
5x3.00	1.50	34.75	22.50	4.21	27,170.10
2x2.00	1.50	44.50	6.00	1.12	11,881.50
4x3.00	1.50	44.50	18.00	3.37	35,644.50
2x2.00	1.50	67.00	6.00	1.12	26,934.00
5x3.00	1.50	67.00	22.50	4.21	101,002.50
4.00	2.00	24.00	8.00	2.66	4,608.00
2x2.00	6.00	22.25	24.00	72.00	11,881.44
2.00	3.00	0.00	6.00	4.50	0
			1,669.50	253,224.15	1,448,644.93

CIRCULAR PART:

$$A = \pi \frac{D_o + D_i}{2} \cdot t = 3.14 \times \frac{42.33 + 32.33}{2} \cdot 5.00 = 586.08 \text{ ft.}^2$$

$$I = \frac{A}{16} (D_o^2 + D_i^2) = \frac{586.08}{16} (42.33^2 + 32.33^2) = 103,921.14 \text{ ft.}^4$$

$$\Sigma A = 1,669.50 + 586.08 = \underline{2,255.58 \text{ ft.}^2}$$

$$\Sigma I = 253,224.15 + 1,448,644.93 + 103,921.14 = \underline{1,805,790.22 \text{ ft.}^4}$$

SHEET NO. 32

JOHN A. BLUME AND ASSOCIATES, ENGINEERS
MONTICELLO REACTOR BUILDING
SEISMIC ANALYSIS

EL. 1001'-2" TO EL. 985'-6"

b ft.	d ft.	L ft.	A=bd ft ²	Ad ² /12 ft. ⁴	AL ² ft. ⁴
2x1.00	137.50	0.00	275.00	433,268.22	0
2.00	26.00	0.00	52.00	2,929.33	0
6.00	10.00	20.00	60.00	500.00	24,000.00
6.00	10.00	20.00	60.00	500.00	24,000.00
5.50	52.00	0.00	286.00	64,445.33	0
1.60	24.00	54.50	38.40	1,843.20	114,057.60
3+2+4	5.00	28.00	45.00	93.75	35,280.00
1.00	30.75	51.00	30.75	2,422.99	79,980.75
26.00	4.00	32.50	104.00	138.67	109,850.00
0.50	19.00	47.00	9.50	285.79	20,985.50
1.00	4.00	39.00	4.00	5.33	6,084.00
2.00	6.00	38.50	12.00	36.00	17,787.00
2.00	9.00	45.00	18.00	121.50	36,450.00
2x1.00	6.00	53.50	12.00	36.00	34,547.00
0.50	16.00	51.50	8.00	170.66	21,218.00
1-(3x1.5)	8.00	63.50	44.00	234.66	177,419.00
1.50+2.50	24.00	56.00	96.00	4,608.00	301,056.00
135.50	1.50	68.00	203.25	38.10	939,828.00
41.00	0.50	67.75	20.50	0.42	94,096.23
6+3+10	1.00	50.50	19.00	1.58	48,454.75
12.67	1.50	44.00	19.01	3.56	36,803.36
132.50	1.50	55.75	198.75	37.27	254,014.92
2x26.00	6.00	22.5	312.00	936.00	157,950.00
2x10.00	1.50	25.00	30.00	5.62	18,750.00
26.00	4.00	23.50	104.00	138.66	57,434.00
11.00	1.00	53.50	11.00	0.92	31,484.75
3.00	2.00	36.50	6.00	2.00	7,993.50
22.00	1.50	45.50	33.00	6.18	68,318.25
4.00	3.00	45.50	12.00	9.00	24,843.00
1.00	3.50	48.00	3.50	3.57	8,064.00
14.00	2.00	45.00	28.00	9.33	56,700.00
42.00	2.50	45.25	105.00	54.68	214,993.80
45.00	2.50	58.00	112.50	58.59	378,450.00

JOHN A. BLUME AND ASSOCIATES, ENGINEERS
MONTICELLO REACTOR BUILDING
SEISMIC ANALYSIS

EL. 1001'-2" TO EL. 985'-6" (CONTINUED)

b ft.	d ft.	L ft.	A ft. ²	Ad ² /12 ft. ⁴	ΔL ² ft. ⁴
45.50	1.00	67.25	45.50	3.79	205,776.48
42.00	0.50	67.50	21.00	0.43	95,681.25
135.50	1.00	68.00	135.50	11.29	626,552.00
9.00	1.00	58.00	9.00	0.75	30,276.00
2x2.00	1.00	34.75	4.00	0.33	4,830.24
5x3.00	1.00	34.75	15.00	1.25	18,113.40
2x3.00	3.00	10.75	18.00	13.50	2,080.08
3.00	2.50	35.00	7.50	3.90	9,187.50
3.00+2.00	2.50	44.50	12.50	6.51	24,753.13
3.00+2.00	1.50	67.00	7.50	1.40	33,667.50
2x2.00	5.00	22.25	20.00	41.66	9,901.20
2.00	2.50	0.00	5.00	2.60	0
1.00	4.00	56.00	4.00	5.33	12,544.00
7.00	1.50	39.50	10.50	1.97	16,382.63
1.50	3.00	37.00	4.50	3.38	6,160.50
			2,619.66	513,043.00	4,496,559.32

CIRCULAR PART :

$$A = 3.14 \times \frac{44.50 + 33.50}{2} \times 5.50 = 673.53 \text{ ft.}^2$$

$$I = \frac{673.53}{16} \times (44.50^2 + 33.50^2) = 130,601.67 \text{ ft.}^4$$

$$\Sigma A = 2,619.66 + 673.53 = \underline{3,365.19 \text{ ft.}^2}$$

$$\Sigma I = 513,043.00 + 4,496,559.32 + 130,601.67 = \underline{5,140,203.99 \text{ ft.}^4}$$

JOHN A. BLUME AND ASSOCIATES, ENGINEERS
MONTICELLO REACTOR BUILDING
SEISMIC ANALYSIS

EL. 985'-6" TO EL. 962'-6"

b ft.	d ft.	L ft.	A = bd ft. ²	Ad ² /12 ft. ⁴	AL ² ft. ⁴
2x1.00	137.50	0.00	275.00	433,268.22	0
2.00	26.00	0.00	52.00	2,929.33	0
2x2.00	10.00	61.00	40.00	333.33	148,840.00
1.00	23.00	45.00	23.00	1,013.91	46,575.00
2.75	10.00	22.50	27.50	229.16	13,421.33
1.50	5.00	15.00	7.50	15.62	1,687.50
1.50	8.00	20.00	12.00	64.00	4,800.00
3.00x ¹⁵ / ₁₀	10.00	21.00	45.00	375.00	19,845.00
1.50x ^{7.0} / _{3.5}	3.50	9.50	13.50	13.78	1,218.37
2.75	13.00	13.00	35.75	503.47	6,041.75
2.75x ^{8.0} / ₄	5.00	22.00	22.00	45.83	10,648.00
2.75x ^{12.0} / ₄	4.00	20.00	33.00	44.00	13,200.00
1.00	52.00	0.00	52.00	11,717.33	0
1.50	47.50	45.00	71.25	13,396.48	144,281.25
4.00x ⁶ / ₂	2.00	25.50	24.00	8.00	15,606.00
4.00	19.00	37.00	76.00	2,286.33	104,044.00
2.75+2.50	17.00	55.50	89.25	2,149.43	274,912.31
2x2.00	5.50	65.00	22.00	55.45	92,950.00
2.75	24.00	56.00	66.00	3,168.00	206,976.00
24.00	1.00	68.00	24.00	2.00	110,976.00
111.50	1.50	67.75	167.25	31.35	767,687.53
8.00	2.75	26.00	22.00	13.86	14,872.00
10.50	2.00	56.00	21.00	7.00	65,856.00
95.00	1.00	56.00	95.00	7.91	123,120.00
24.00	0.50	35.25	12.00	0.25	14,910.72
17+9+6+4	2.00	34.50	72.00	24.00	85,698.00
2.00+7.00	2.75	26.00	24.75	15.59	16,731.00
19.00	1.50	11.50	28.50	5.34	3,769.13
25.00	1.50	0.75	37.50	7.03	21.00
11.00	4.00	23.50	44.00	58.66	24,299.00
6.50	2.75	24.00	17.88	11.26	10,298.88
26.00	3.25	44.50	84.50	74.36	167,331.13
35.00	2.75	44.25	96.25	60.63	188,463.23

JOHN A. BLUME AND ASSOCIATES, ENGINEERS
MONTICELLO REACTOR BUILDING
SEISMIC ANALYSIS

EL. 985'-0" TO EL. 962'-0" (CONTINUED)

b ft.	d ft.	L ft.	A = bd ft. ²	Ad ² /12 ft. ⁴	AL ² ft. ⁴
2.75+1.50	6.50	3.00	27.63	97.26	248.63
26.00	2.50	67.50	65.00	33.85	296,156.25
54.00	1.50	68.00	81.00	15.18	374,544.00
48.00	1.00	68.25	48.00	4.00	223,586.88
9.00	1.00	58.00	9.00	0.75	30,276.00
2x11.00	1.00	26.00	22.00	1.83	14,872.00
2.00+3.00	3.00	35.25	15.00	12.00	18,638.40
2.00	2.00	22.25	4.00	1.33	1,980.24
2.00	3.00	35.00	6.00	4.50	7,350.00
3+3+2	3.00	44.50	24.00	18.00	47,526.00
2.5+3.0	1.50	68.00	8.25	1.54	38,148.00
3+3+2	2.00	68.25	16.00	5.33	74,528.96
2x2.50	5.00	22.25	25.00	52.08	12,376.50
2.50	2.50	0.00	6.25	3.25	0
			2,090.51	472,184.81	3,839,812.59

CIRCULAR PART:

$$A = 3.14 \times \frac{45.50 + 33.50}{2} \times 6.00 = 744.18 \text{ ft.}^2$$

$$I = \frac{744.18}{16} \times (45.50^2 + 33.50^2) = 148,487.16 \text{ ft.}^4$$

$$\Sigma A = 2,090.51 + 744.18 = \underline{2,834.69 \text{ ft.}^2}$$

$$\Sigma I = 472,184.81 + 3,839,812.59 + 148,487.16 = \underline{4,460,484.56 \text{ ft.}^4}$$

JOHN A. BLUME AND ASSOCIATES, ENGINEERS
MONTICELLO REACTOR BUILDING
SEISMIC ANALYSIS

EL. 962'-6" TO EL. 935'-0"

b ft.	d ft.	L ft.	A=bd ft. ²	Ad ² /12 ft. ⁴	ΔL ² ft. ⁴
2x1.00	137.50	0.00	275.00	433,268.22	0
2.00	26.00	0.00	52.00	2,929.33	0
1.00	36.00	51.00	36.00	3,888.00	93,636.00
4.00	29.00	49.00	116.00	8,129.66	278,516.00
4.00	33.50	51.00	134.00	12,531.79	348,534.00
3.00x $\frac{11}{8}$	8.00	45.00	33.00	176.00	66,825.00
2.50x $\frac{30}{27}$	21.00	30.50	75.00	2,756.25	69,768.75
134.50	1.00	68.25	134.50	11.20	626,509.07
23.00	1.00	67.25	23.00	1.91	104,018.88
32+52	2.00	67.25	168.00	56.00	759,790.08
8.00	1.00	56.00	8.00	0.66	25,088.00
26.00	2.50	48.50	65.00	33.85	152,896.25
7.00	2.00	35.00	14.00	4.66	17,150.00
9.00	1.00	58.00	9.00	0.75	30,276.00
34.00	0.5	68.00	17.00	0.35	78,608.00
116.50	1.00	68.25	116.50	9.70	542,663.99
2x2.00	2.50	44.50	10.00	5.20	19,802.50
2x3.50	3.50	44.50	24.50	25.01	48,516.13
2x2+3x3.	1.50	67.00	19.50	3.65	87,535.50
2x3.00	1.00	66.75	6.00	0.50	26,533.50
2x2.50	6.00	23.00	30.00	90.00	15,870.00
2.50	3.00	0.00	7.50	5.62	0
11.00	1.50	59.00	16.50	3.09	57,436.50
18.00	1.00	51.00	18.00	1.50	46,818.00
13.00	1.00	46.50	13.00	1.08	28,109.25
2x1.00	3.00	48.75	6.00	4.50	14,259.38
1.50	5.00	64.50	7.50	15.63	31,201.88
1.50x $\frac{13.50}{9.00}$	9.00	58.00	20.25	136.69	68,121.00
1.50x $\frac{3.50}{3.00}$	3.00	54.00	5.25	3.94	15,309.00
37.50	2.00	54.50	75.00	25.00	222,768.75
2.00	12.00	49.00	24.00	288.00	57,624.00
2.00	8.00	45.00	16.00	85.33	32,400.00
2.00x $\frac{12.00}{8.50}$	8.50	50.00	24.00	144.49	59,944.37
			1,559.00	464,637.56	4,026,584.78

JOHN A. BLUME AND ASSOCIATES, ENGINEERS
MONTICELLO REACTOR BUILDING
SEISMIC ANALYSIS

EL. 962'-6" TO EL. 935'-0" (CONTINUED)

CIRCULAR PART:

$$A = 3.14 \times \frac{72.00 + 62.00}{2} \times 5.00 - 5.00 \times (9.00 + 10.00) =$$

$$= 1,051.90 - (45.00 + 50.00) = 956.90 \text{ ft.}^2$$

$$I = \frac{1,051.90}{16} \times (72.00^2 + 62.00^2) - 45.00 \times \left(\frac{5.00^2}{12} + 33.5^2 \right) - 50.00 \times \left(\frac{7.50^2}{12} + 23.50^2 \right) =$$

$$= 593,534.57 - (50,594.85 + 27,846.50) = 515,093.22 \text{ ft.}^4$$

SHIELD: $A = \frac{1}{2} \times 3.14 \times (25 + 17) \times 4 = 267.76 \text{ ft.}^2$

$$\Sigma A = 1559.00 + 956.90 + 267.76 = \underline{2,783.66 \text{ ft.}^2}$$

$$\Sigma I = 464,637.56 + 4,026,584.78 + 515,093.22 = \underline{5,006,315.56 \text{ ft.}^4}$$

JOHN A. BLUME AND ASSOCIATES, ENGINEERS
MONTICELLO REACTOR BUILDING
SEISMIC ANALYSIS

EL. 935'-0" TO EL. 896'-3"

b ft.	d ft.	L ft.	$\Delta = bd$ ft. ²	$Ad^2/12$ ft. ⁴	ΔL^2 ft. ⁴
3.50+3.50	137.50	0.00	962.50	1,516,438.80	0
3.00	25.00	0.00	75.00	3,906.25	0
4[3.00 x $\frac{35}{23}$]	25.00	47.00	420.00	21,875.00	927,780.00
4 x 5.00	7.50	32.00	150.00	703.12	153,600.00
2 x 130.00	3.50	67.00	910.00	92,895.83	4,084,940.00
40.00	3.00	70.25	120.00	90.00	592,207.20
5 x 4.00	1.00	65.00	20.00	1.66	84,500.00
2 x 1.00	4.00	9.50	8.00	10.66	722.00
4 x 7.50	5.00	62.00	150.00	312.50	576,600.00
4[4.00 x $\frac{8}{7}$]	7.00	21.00	128.00	522.66	56,488.00
4[4.00 x $\frac{8}{3}$]	3.00	9.00	128.00	96.00	10,368.00
28.00	3.50	67.00	98.00	100.04	439,922.00
28.00	3.50	13.50	98.00	100.04	17,860.50
3.50	57.00	40.25	199.50	54,014.63	323,202.37
			3,467.00	1,691,067.19	7,268,240.07

CIRCULAR PARTS:

$$A = 3.14 \times \frac{68.00 + 54.00}{2} \times 7.00 = 1,340.78 \text{ ft.}^2$$

$$I = \frac{1,340.78}{16} \times (68.00^2 + 54.00^2) = 631,842.57 \text{ ft.}^4$$

$$A = \frac{3.14}{4} \times 38^2 = 1,133.54 \text{ ft.}^2$$

$$I = \frac{1,133.54}{16} \times 38^2 = 102,301.98 \text{ ft.}^4$$

$$\Sigma A = 3,467.00 + 1,340.78 + 1,133.54 = \underline{5,941.32 \text{ ft.}^2}$$

$$\Sigma I = 1,691,067.19 + 7,268,240.07 + 631,842.57 + 102,301.98 = \underline{9,693,451.81 \text{ ft.}^4}$$

JOHN A. BLUME AND ASSOCIATES, ENGINEERS
MONTICELLO REACTOR BUILDING
SEISMIC ANALYSIS

b. EARTHQUAKE IN E-W DIRECTION (N-S AXIS)
EL. 1027'-0" TO EL. 1001'-2"

b ft.	d ft.	L ft.	A=bd ft. ²	Ad ² /12 ft. ⁴	AL ² ft. ⁴
2x105.25	1.00	68.25	210.50	17.54	980,522
24.00	1.00	67.25	24.00	2.00	108,541
14.00	6.00	17.50	84.00	252.00	25,725
14.00	6.00	17.50	84.00	252.00	25,725
50.50	5.00	49.50	252.50	526.04	618,638
15.00	1.00	0	15.00	1.25	0
13.00	1.00	58.00	13.00	1.08	43,732
1.00	135.50	0	135.50	207,317.82	0
1.00	135.50	0	135.50	207,317.82	0
5.50	26.00	34.00	143.00	8,055.67	165,308
5.00	26.00	34.00	130.00	7,323.33	150,280
2x2.50	47.00	45.00	235.00	43,259.58	475,875
2.00	11.00	61.00	22.00	221.83	81,862
1.00	57.50	29.00	57.50	15,842.45	48,358
1.00	9.00	64.00	9.00	60.75	36,864
2x1.50	2.00	67.25	6.00	2.00	27,135
4x1.50	3.00	34.00	18.00	12.00	20,808
2x1.50	2.00	67.25	6.00	2.00	27,135
4x1.50	3.00	34.00	18.00	12.00	20,808
2x1.50	2.00	67.25	6.00	2.00	27,135
4x1.50	3.00	34.00	18.00	12.00	20,808
2.00	4.00	60.00	8.00	10.67	28,300
2x6.00	2.00	66.75	24.00	8.00	106,433
3.00	2.00	66.75	6.00	2.00	26,733
				490,513.83	3,067,775

CIRCULAR PART:

$$I = 103,921.14 \text{ ft.}^4$$

$$\Sigma I = 103,921.14 + 490,513.83 + 3,067,775.00 = \underline{\underline{3,662,209.97 \text{ ft.}^4}}$$

JOHN A. BLUME AND ASSOCIATES, ENGINEERS
MONTICELLO REACTOR BUILDING
SEISMIC ANALYSIS

EL.1001'-2" TO EL.985'-6"

b ft.	d ft.	L ft.	A=bd ft. ²	$\Delta d^2/12$ ft. ⁴	ΔL^2 ft. ⁴
2x137.50	1.00	68.25	275.00	22.91	1,280,967
26.00	2.00	66.75	52.00	17.33	231,689
10.00	6.00	17.50	60.00	180.00	18,375
10.00	6.00	17.50	60.00	180.00	18,375
52.00	5.50	49.00	282.00	710.87	677,082
24.00	1.60	44.50	38.40	8.19	76,042
5.00	3.00	67.50	15.00	11.25	68,344
5.00	2.00	56.00	10.00	3.33	31,360
30.75	1.00	26.50	30.75	2.56	21,594
5.00	4.00	43.00	20.00	26.67	33,280
4.00	26.00	54.00	104.00	5,858.67	303,264
1.00	6.00	46.00	6.00	18.00	12,696
19.00	0.50	67.50	9.50	0.19	43,284
4.00	1.00	56.00	4.00	0.33	12,544
6.00	2.00	37.50	12.00	4.00	16,375
9.00	2.00	42.00	18.00	6.00	31,752
6.00	1.00	51.50	6.00	0.50	15,914
6.00	1.00	59.00	6.00	0.50	20,336
16.00	0.50	23.50	8.00	0.16	4,418
8.00	1.00	67.25	8.00	0.67	36,180
8.00	1.50	56.00	12.00	2.25	37,632
8.00	1.50	45.00	12.00	2.25	24,300
8.00	1.50	34.00	12.00	2.25	13,372
24.00	4.00	22.00	96.00	128.00	46,464
1.50	135.50	0	203.25	310,976.73	0
0.50	41.00	47.50	20.50	2,871.70	46,253
1.00	3.00	38.50	3.00	2.25	4,447
1.50	12.67	38.00	19.01	254.19	27,450
1.50	135.50	0	203.25	310,976.73	0
2x6.00	26.00	34.00	312.00	17,576.00	8,925

JOHN A. BLUME AND ASSOCIATES, ENGINEERS
MONTICELLO REACTOR BUILDING
SEISMIC ANALYSIS

EL. 1001'-2" TO EL. 985'-6" (CONTINUED)

b ft.	d ft.	L ft.	A = bd ft. ²	Ad ² /12 ft. ⁴	AL ² ft. ⁴
2x1.50	10.00	61.00	33.00	275.00	122,793
1.00	10.00	29.00	10.00	83.33	8,410
2.00	3.00	40.00	6.00	4.50	9,600
1.50	22.00	57.50	33.00	1,331.00	109,106
3.00	4.00	45.50	12.00	16.00	24,343
1.00	11.00	38.50	11.00	110.92	16,305
2.00	14.00	31.00	28.00	457.33	26,903
2.50	42.00	0	105.00	15,435.00	0
2.50	45.00	46.00	112.50	18,984.37	238,050
1.00	45.50	45.50	45.50	7,844.69	94,163
0.50	42.00	0	21.00	3,087.00	0
1.00	135.50	0	135.50	207,317.82	0
1.00	9.00	64.00	9.00	60.75	36,804
2x1.00	2.00	66.75	4.00	1.33	17,822
4x1.00	3.00	34.00	15.00	11.25	17,340
2x3.00	3.00	44.50	18.00	13.50	35,645
2.50	3.00	0	7.50	5.62	0
2.50+1.50	5.00	56.00	20.00	41.66	62,720
2x5.00	2.00	66.75	20.00	6.66	89,111
2.50	2.00	66.75	5.00	1.66	22,273
3.50	1.00	37.50	3.50	0.29	4,922
4.00	1.00	34.00	4.00	0.33	4,624
1.50	7.00	62.50	10.50	42.88	41,016
3.00	1.50	60.00	4.50	0.84	16,200
				904,983.21	4,166,684

CIRCULAR PART:

$$I = 130,601.67 \text{ ft.}^4$$

$$\Sigma I = 130,601.67 + 904,983.21 + 4,166,684 = \underline{\underline{5,202,268.88 \text{ ft.}^4}}$$

JOHN A. BLUME AND ASSOCIATES, ENGINEERS
MONTICELLO REACTOR BUILDING
SEISMIC ANALYSIS

EL. 985'-6" TO EL. 962'-6"

b ft.	d ft.	L ft.	A=bd ft. ²	Ad ² /12 ft. ⁴	AL ² ft. ⁴
2x137.50	1.00	68.25	275.00	22.91	1,280,967
26.00	2.00	66.75	52.00	17.33	231,634
10.00	2.00	41.00	20.00	66.67	33,620
10.00	2.00	28.50	20.00	66.67	16,645
23.00	1.00	28.00	23.00	1.91	18,030
10.00	2.75	45.00	27.50	200.65	55,635
5.00	1.50	34.00	7.50	1.40	8,670
8.00	1.50	29.50	12.00	2.25	10,443
3x $\frac{15}{16}$	10.00	21.00	45.00	375.00	19,345
1.5x $\frac{9}{8}$	8.00	24.00	13.50	72.00	7,776
13.00	2.75	45.50	35.75	22.52	74,011
2.75x $\frac{8}{3}$	5.00	43.00	22.00	45.83	40,673
2.75x $\frac{12}{4}$	4.00	20.00	55.00	44.00	13,200
52.00	1.00	54.50	52.00	4.33	154,455
47.50	1.50	67.00	71.25	13.35	319,341
4x $\frac{6}{2}$	2.00	53.00	24.00	8.00	67,416
19.00	4.00	51.00	76.00	101.33	197,676
17.00	2.75	22.50	36.75	23.15	18,605
17.00	2.50	45.00	42.50	22.13	86,063
5.50	2.00	28.50	11.00	3.66	8,935
5.50	2.00	39.50	11.00	3.66	17,163
24.00	2.75	15.00	66.00	41.58	14,350
1.00	24.00	58.00	24.00	1,522.00	80,736
1.50	111.50	12.00	167.25	173,274.48	24,034
2.75	8.00	36.00	22.00	117.33	28,511
2.00	10.50	35.00	21.00	192.43	25,725
1.00	95.00	20.00	95.00	71,447.91	38,000
0.50	24.00	0	12.00	576.00	0
2.00	17.00	21.00	34.00	818.83	14,994
2.00	12.00	18.00	24.00	288.00	7,776

JOHN A. BLUME AND ASSOCIATES, ENGINEERS
MONTICELLO REACTOR BUILDING
SEISMIC ANALYSIS

EL. 985'-6" TO EL. 962'-6" (CONTINUED)

b ft.	d ft.	L ft.	A=bd ft. ²	Ad ² /12 ft. ⁴	AL ² ft. ⁴
2.00	3.00	44.50	6.00	4.50	11,382
2.00	2.00	66.75	4.00	1.33	17,822
2.75	9.00	30.00	24.75	167.06	22,275
1.50	19.00	38.00	28.50	857.37	41,154
1.50	25.00	34.50	37.50	1,953.12	44,634
4.00	11.00	61.00	44.00	443.66	163,724
2.75	6.50	28.00	17.88	62.95	14,018
3.25	26.00	36.50	84.50	4,760.16	112,575
2.75	35.00	4.00	96.25	9,825.52	1,540
6.50	1.50	34.00	9.75	1.83	11,270
2.50	26.00	53.50	65.00	3,661.66	186,046
1.50	54.00	12.00	81.00	19,683.00	11,664
1.00	48.00	45.00	48.00	9,216.00	97,200
1.00	9.00	64.00	9.00	60.75	36,364
2x1.00	11.00	60.50	22.00	221.83	80,526
3.00	3.00	44.50	9.00	6.75	17,822
3.00	2.00	66.75	6.00	2.00	26,723
2.00	2.00	22.25	4.00	1.33	1,480
3.00	2.00	0	6.00	2.00	0
5.00	8.00	44.50	40.00	213.33	79,210
1.50	2.50	0	8.25	4.29	0
2x5.00	2.50	66.50	25.00	13.02	110,556
2.50	2.50	66.50	6.25	3.25	27,634
				300,194.52	4,032,326

CIRCULAR PART:

$$I = 148,487.16 \text{ ft.}^4$$

$$\Sigma I = 148,487.16 + 300,194.52 + 4,032,326.00 = \underline{\underline{4,481,507.68 \text{ ft.}^4}}$$

JOHN A. BLUME AND ASSOCIATES, ENGINEERS
MONTICELLO REACTOR BUILDING
SEISMIC ANALYSIS

EL. 962'-6" TO EL. 935'-0"

b ft.	d ft.	L ft.	A=bd ft. ²	Ad ² /12 ft. ⁴	AL ² ft. ⁴
2x137.50	1.00	68.25	275.00	22.91	1,280,967
26.00	2.00	66.75	52.00	17.33	231,689
36.00	1.00	67.25	36.00	3.00	162,812
29.00	4.00	14.00	116.00	154.66	22,736
33.50	4.00	14.00	134.00	178.66	26,264
3x $\frac{4}{8}$	8.00	45.00	33.00	176.00	66,825
2.5x $\frac{30}{21}$	21.00	41.00	75.00	2,756.25	126,075
1.00	134.50	0	134.50	202,761.55	0
1.00	23.00	56.00	23.00	1,013.92	72,128
2.00	32.00	28.00	64.00	5,461.33	50,176
2.00	52.00	42.00	104.00	23,434.67	183,456
1.00	8.00	20.00	8.00	42.67	3,200
2.50	26.00	33.00	65.00	3,661.67	70,785
2.00	7.00	63.00	14.00	57.17	55,566
1.00	9.00	64.00	9.00	60.75	36,864
0.50	34.00	10.00	17.00	1,637.67	1,700
1.00	116.50	0	116.50	322,552.09	0
2x2.50	2.00	66.75	10.00	3.33	44,556
2x3.50	3.50	51.00	24.50	25.01	63,725
2x1.50	2.00	66.75	6.00	2.00	26,733
2x1.50	3.00	44.50	9.00	6.75	17,822
2x1.00	3.00	22.25	6.00	4.50	2,970
2x6.00	2.50	66.50	30.00	15.63	132,668
3.00	2.50	66.50	7.50	3.91	33,167
1.50	11.00	62.50	16.50	166.38	64,453
1.00	18.00	54.50	18.00	486.00	53,465
1.00	13.00	57.00	13.00	183.08	42,236
2.00	1.00	63.00	2.00	0.17	7,935
2.00	1.00	46.00	2.00	0.17	4,230
5.00	1.50	33.50	7.50	1.41	8,416
1.50x $\frac{13.50}{9.00}$	9.00	38.00	20.25	136.69	29,241
1.50x $\frac{3.50}{3.00}$	3.00	44.50	5.25	3.94	10,596
2.00	37.50	5.00	75.00	8,789.06	1,875
12.00	2.00	23.00	24.00	8.00	12,696
8.00	2.00	22.00	16.00	5.33	7,744
2.00x $\frac{12.00}{8.00}$	8.00	18.00	24.00	128.00	7,776
				573,961.66	2,963,347

CIRCULAR PART:

$$I = 515,093.22 \text{ ft.}^4$$

$$\Sigma I = 515,093.22 + 573,961.66 + 2,963,347 = \underline{4,052,401.88 \text{ ft.}^4}$$

SHEET NO. 43

JOHN A. BLUME AND ASSOCIATES, ENGINEERS
MONTICELLO REACTOR BUILDING
SEISMIC ANALYSIS

EL. 935'-0" TO EL. 896'-3"

b ft.	d ft.	L ft.	A=bd ft. ²	Ad ³ /12 ft. ⁴	AL ² ft. ⁴
2x137.50	3.50	67.00	962.50	982.55	4,320,663
25.00	3.00	70.25	75.00	112.50	370,130
4[3x $\frac{35}{8}$]	25.00	47.00	420.00	21,875.00	927,780
4x7.50	5.00	62.50	150.00	312.50	585,938
2x3.50	130.00	0	910.00	1,281,583.33	0
3.00	40.00	0	120.00	16,000.00	0
4x1.00	5.00	13.00	20.00	41.67	3,380
2x4.00	1.00	64.75	8.00	.67	33,540
4x5.00	7.50	32.00	150.00	703.13	153,600
4[4x $\frac{8}{3}$]	3.00	9.00	128.00	96.00	10,368
4[4x $\frac{8}{3}$]	7.00	21.00	128.00	522.67	56,448
2x3.5	28.00	82.75	196.00	12,805.33	1,342,122
57.00	3.50	98.50	199.50	203.66	1,935,599
				1,335,239.01	9,739,568

CIRCULAR PARTS:

$$I = 631,842.57 + 102,301.98 = 734,144.55 \text{ ft.}^4$$

$$\Sigma I = 734,144.55 + 1,335,239.01 + 9,739,568.00 = \underline{\underline{11,808,951.56 \text{ ft.}^4}}$$

GENERAL ELECTRIC COMPANY
ATOMIC POWER EQUIPMENT DEPARTMENT

MONTICELLO NUCLEAR GENERATION PLANT
EARTHQUAKE ANALYSIS:
DRYWELL

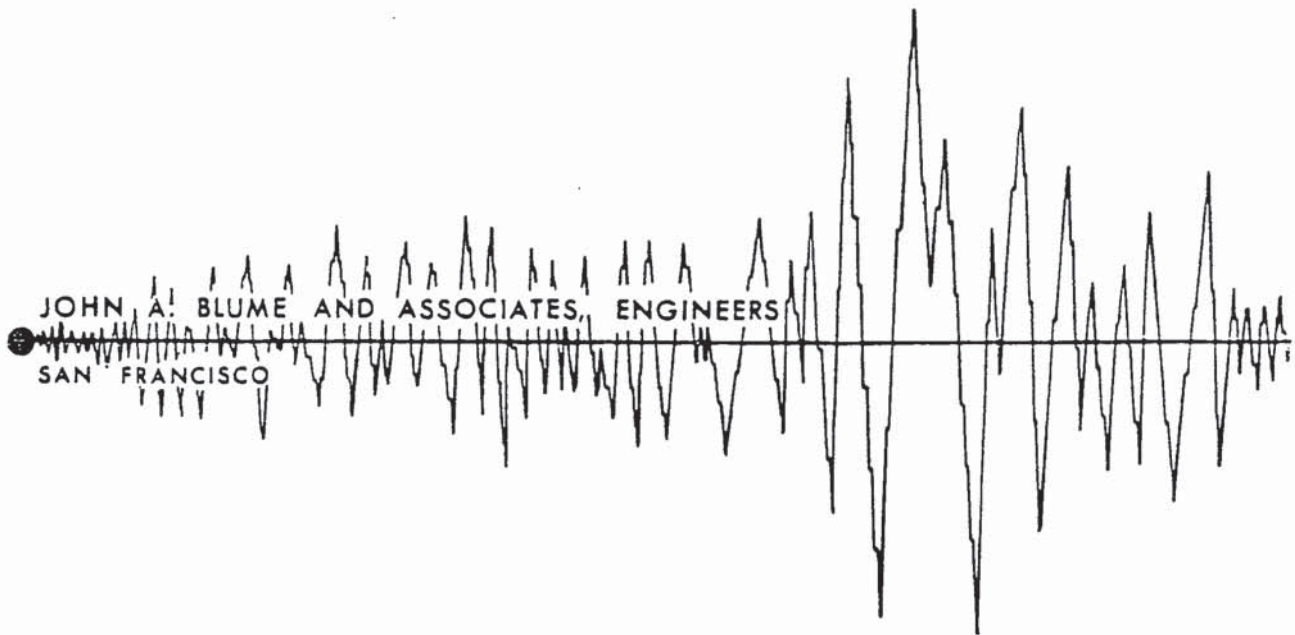

JOHN A. BLUME & ASSOCIATES, ENGINEERS

612 HOWARD STREET • SAN FRANCISCO, CALIFORNIA 94105 • (415) 397-2525

JOHN A. BLUME
ROLAND L. SHARPE
JOSEPH P. NICOLETTI
DONALD M. TEIXEIRA
JAMES M. KEITH
EDWARD J. KEITH
LLOYD A. LEE
RALPH T. YOKOYAMA

December 27, 1967

General Electric Company
Atomic Power Equipment Department
175 Curtner Avenue
San Jose, California 95125

ATTENTION: Mr. R. B. Gile
MC-750

SUBJECT: Monticello Nuclear Generation Plant
Earthquake Analysis of
Drywell

Gentlemen:

Transmitted herein is the subject report based on information furnished by
General Electric Company.

This report summarizes the analytical procedures and results for the seismic
analysis of Monticello Drywell for both empty and flooded conditions.

Very truly yours,

JOHN A. BLUME & ASSOCIATES, ENGINEERS

E. J. Keith

E. J. Keith
Assistant Vice President

MPJ/ps

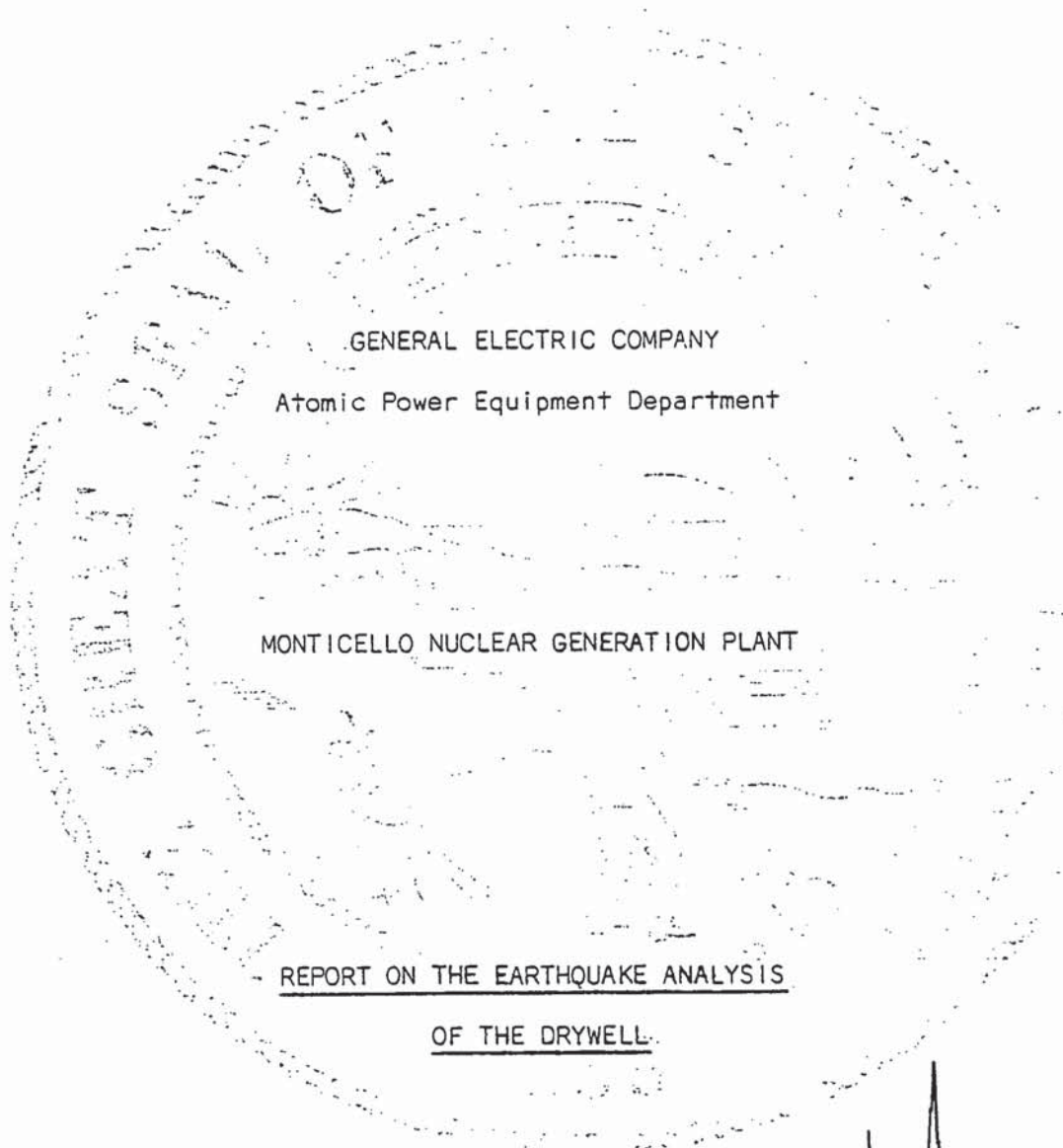

GENERAL ELECTRIC COMPANY
Atomic Power Equipment Department

MONTICELLO NUCLEAR GENERATION PLANT

REPORT ON THE EARTHQUAKE ANALYSIS
OF THE DRYWELL.

JOHN A. BLUME AND ASSOCIATES, ENGINEERS
SAN FRANCISCO

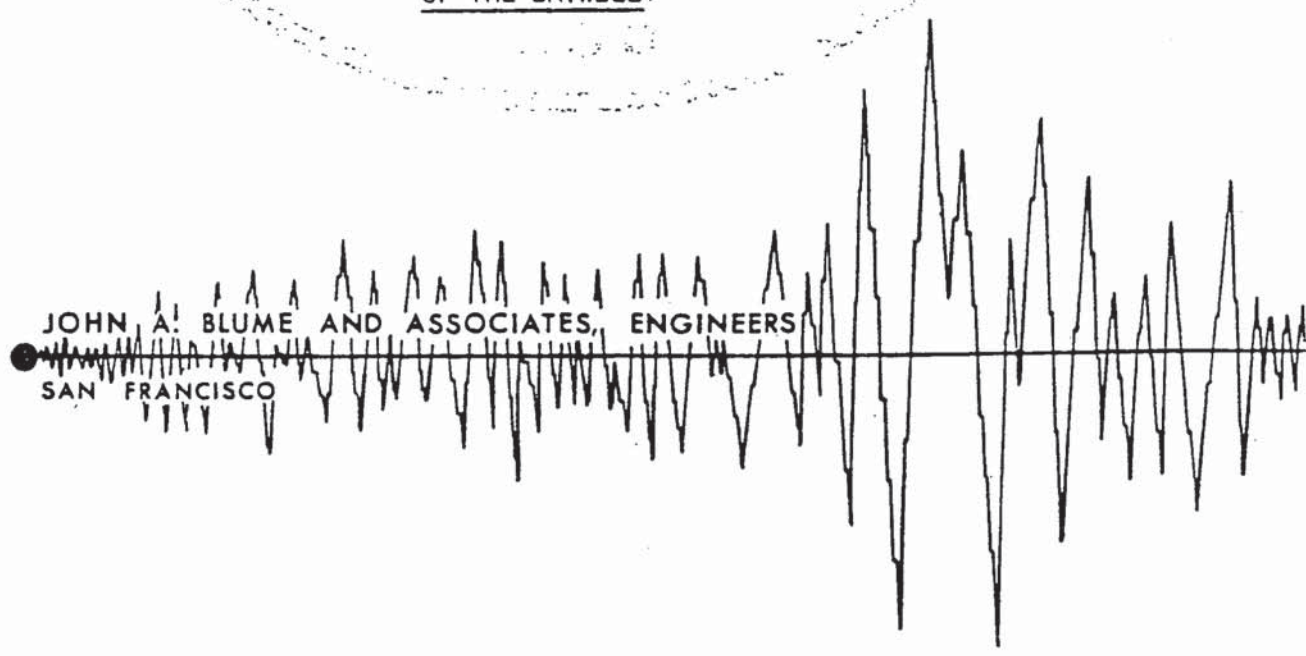

MONTICELLO NUCLEAR GENERATION PLANT
EARTHQUAKE ANALYSIS OF DRYWELL

TABLE OF CONTENTS

	<u>Page</u>
Introduction	1
Design Criteria	1
Description of Drywell	1
Mathematical Model of Drywell	1
Calculated Data	2
Analytical Procedure	2
Mode Shapes and Periods	2
Response	3
Computer Program	5
Results	7
Recommendations	8
References	10
Appendix - Data and Design Figures	11

MONTICELLO NUCLEAR GENERATION PLANT
EARTHQUAKE ANALYSIS OF DRYWELL

INTRODUCTION

The purpose of this report is to summarize the analytical procedures and results of seismic investigation of the Monticello Drywell. Based on the design earthquake stated below, design envelopes of seismic-induced maximum absolute acceleration, relative displacement, moment and shear versus height of the drywell have been developed and are presented herein. The design earthquake acting in the north-south and east-west directions has been considered for both empty and flooded conditions of the drywell.

DESIGN CRITERIA

Earthquake design criteria are presented in detail in Reference 1. The design earthquake used in this analysis is the north 69° west component of Taft earthquake of 1952 normalized to a maximum ground acceleration of 0.06 gravity.

DESCRIPTION OF DRYWELL

The drywell is a bulb shaped steel shell of variable plate thickness. The spherical part has an inside radius of 32'.0" and is joined to the cylindrical part of the drywell by a knuckle of plate thickness 2.5 inches. The cylindrical part consists of three cylindrical shells 23'-8", 3'-0" & 6'-3" long, having inside radii of 16'-6", 13'-5-3/4", 13'-5-3/4", plate thickness of 0.635 inch, 1.5 and 1.25 inches respectively, joined by a 5'-3" high truncated cone of plate thickness 1.25 inches. The drywell is embedded in concrete at elevation 917'-11-3/16" and is laterally supported by the reactor building at elevation 992'-5-1/2". Location of personnel lock vent system and geometry of drywell is shown in Appendix Sheet 1.

MATHEMATICAL MODEL OF DRYWELL

The drywell is idealized as a lumped mass system supported on elastic columns. The drywell was mathematically modelled as an eighteen mass system and is shown in Appendix Sheet 3. However, to take into consideration

the interaction of the reactor building and drywell during an earthquake occurrence, the drywell model was coupled with the mathematical model of the reactor building (Reference 2) by an inextensible bar at elevation 992'-5-1/2" representing the shear lug, and by another such bar at elevation 917'-11-3/16" representing the embedment of drywell in the reactor building. This results in a twenty-six lumped mass coupled system which is shown in Appendix Sheet 2.

CALCULATED DATA

Calculated data used as input to the computer is given in Appendix Sheet 3. These calculations result from information or drawings supplied by General Electric (Reference 3).

Properties of the elastic column were determined by cutting a horizontal section between mass points and calculating the moment of inertia and effective shear area. The data presented in Reference 2 were suitably modified for use in this analysis. The mass of personnel lock and vent system was considered and appropriately lumped along with the drywell mass.

The following values were assigned as the elastic moduli:

- | | |
|---------------------|---|
| 1. Concrete | 3.0×10^6 pounds per square inch |
| 2. Drywell Steel | 29.5×10^6 pounds per square inch |
| 3. Structural Steel | 30.0×10^6 pounds per square inch |

ANALYTICAL PROCEDURE - Periods and Mode Shapes

The natural periods of vibration and mode shapes of the mathematical model are calculated by solving for the eigenvalues and eigenvectors of the n number of equations represented by Equation (1).

$$\underline{K} \underline{\phi}_i - \omega_i^2 \underline{M} \underline{\phi}_i = \underline{0} \text{ ----- (1)}$$

where:

\underline{K} = Structure stiffness matrix

ϕ_i = Mode shape vector of the i^{th} mode of vibration

$\underline{\phi}_i$ = Mode shape matrix

ω_i = Natural circular frequency of the i^{th} mode

$i = 1, 2, 3, \dots, n$

n = Number of degrees of freedom of the mathematical model

\underline{M} = Mass matrix

$\underline{0}$ = Null matrix

ANALYTICAL PROCEDURE - Response

The generalized displacement response of the structure, once periods and mode shapes have been determined, is given by Equation (2).

$$\underline{\ddot{Y}}_i(+) + 2 \omega_i \lambda_i \underline{\dot{Y}}_i(+) + \omega_i^2 \underline{Y}_i(+) = \frac{\underline{R}_i}{\underline{M}_i^*} \underline{\ddot{U}}_g(+) \quad \text{-----}(2)$$

where:

$\underline{Y}_i(+) =$ Generalized coordinate vector for the i^{th} mode

$\underline{Y}_i(+) =$ Generalized coordinate matrix

$\underline{\dot{Y}}_i(+) =$ Generalized velocity matrix

$\underline{\ddot{Y}}_i(+) =$ Generalized acceleration matrix

$\lambda_i =$ Damping value for the i^{th} mode

$\underline{M}_i^* =$ Generalized mass matrix which is set equal to unity in eigenvalue solution

$$= \underline{\phi}_i^T \cdot \underline{M} \cdot \underline{\phi}_i$$

$\frac{\underline{R}_i}{\underline{M}_i^*} =$ Participation factor matrix

$$\underline{M}_i$$

$$\underline{R}_i = \underline{\phi}_i^T \cdot \underline{M}$$

$\ddot{U}_g(+)$ = Ground motion

The generalized coordinate vector for the i^{th} mode is given as:

$$Y_i(+)=\frac{R_i}{M_i^* \omega_i} \int_0^+ U_g(+)\ e^{-\lambda_i \omega_i (+-\tau)} (\sin \omega_i (+-\tau)) d\tau$$

Where:

$d\tau$ = Integration interval

R_i = Participation factor for the i^{th} mode

M_i^* = Generalized mass for i^{th} mode

The integral in the above expression, called the Duhamel Integral is numerically integrated.

From the generalized coordinate matrix the time history of displacement, $\underline{V}_{(+)}$, is found from Equation (3).

$$\underline{V}_{(+)} = \underline{\phi}_i \cdot \underline{Y}_i(+)$$
 -----(3)

The solution for generalized acceleration response is identical to the above, except that Equation (2) is solved for acceleration, from which the relative acceleration-time history matrix is calculated. To this is added the ground acceleration, resulting in the absolute acceleration-time history.

Once displacement and acceleration-time histories have been established, the time histories of shears and moments are determined. These records are then enveloped to determine the maximum values which are then graphically presented in the report and are recommended for use by the designer.

ANALYTICAL PROCEDURE - Computer Program

The computer program used in this analysis was specially designed to solve the dynamic response of structures subjected to arbitrary ground motions. The effects of axial deformation and shear deformations are included in the calculation of the stiffness matrix. Individual elements in the stiffness matrix are designated K_{ij} and are stored in the computer such that the i^{th} value designates the row number and the j^{th} value the column number. K_{ij} is determined by applying a unit displacement at the j^{th} point while restraining the other points against distortion, and finding the corresponding reaction at the i^{th} point.

The computer retains the response of each mass for each individual mode at each increment of time, and the total response for each increment of time is obtained by adding together the responses of each mass point for each mode at a particular instant of time. This results in an exact combination of mode participations without the necessity of using approximate methods such as the root-mean-square method.

The increment of time referred to above is used in the step-by-step integration of Duhamel's Integral and is selected by the computer such that it is always smaller than one-tenth of the period of vibration of the mode for which the response is calculated. The computer takes into account all peaks and valleys of the design ground motion.

The general computer techniques used in this analysis are taken from References 4, 5, 6, and 7. A simplified block diagram of the computer program is shown in Diagram 1.

MONTICELLO NUCLEAR GENERATION PLANT
EARTHQUAKE ANALYSIS OF DRYWELL

COMPUTER PROCESS DIAGRAM

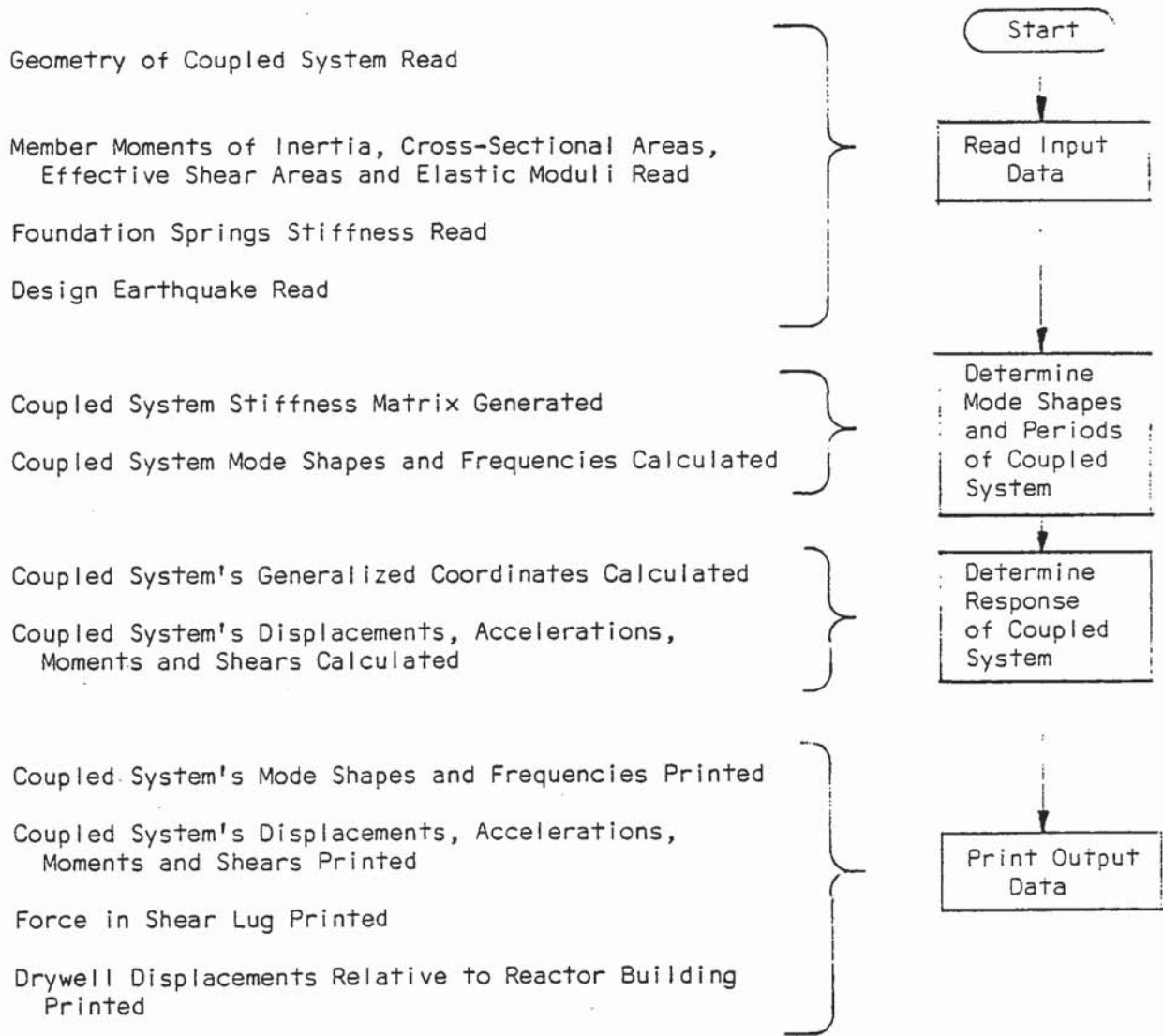

RESULTS

The analysis was performed with the aid of an IBM 1130 digital computer. A damping value of three percent was assigned to all modes of the coupled system. The influence of seventh and higher modes of vibration was considered negligible and, therefore, ignored in the coupled system's response calculations.

Periods

The following table summarizes the natural periods of vibration for the coupled system in the east-west and the north-south directions for both empty and flooded conditions of drywell.

Periods of Vibration in Seconds

Mode of Vibration	East-West Direction		North-South Direction	
	Drywell Empty	Drywell Flooded	Drywell Empty	Drywell Flooded
First	0.542	0.556	0.590	0.597
Second	0.222	0.223	0.208	0.210
Third	0.185	0.187	0.180	0.181
Fourth	0.052*	0.103*	0.053*	0.103*
Fifth	0.045	0.052	0.041	0.053
Sixth	0.039	0.045	0.040	0.045

* Reflects fundamental period of the drywell

Response

The envelopes of maximum absolute accelerations, maximum shears, maximum moments and maximum displacements (relative to the base of the reactor building) induced by seismic loading in the east-west direction are presented in Appendix Sheets 4, 5, 6, and 7 respectively.

Similar results for seismic loading in the north-south direction are presented in Appendix Sheets 8 through 11.

Maximum displacements of empty drywell relative to the reactor building for earthquake acting in north-south direction are presented in Appendix Sheet 12.

Forces and Displacement at Shear Lug

The following table gives the maximum value of force, in drywell shear lug at elevation 992'-5-1/2", induced during the excursions of the design earthquake.

(Note: Maximum force includes effect of drywell only)

Case	East-West Direction	North-South Direction
Drywell Empty	81 Kips	111 Kips
Drywell Flooded	90 Kips	138 Kips

The maximum displacement of the empty drywell at shear lug elevation relative to its embedment point at elevation 917'-11-3/16" is 33 mils. This does not include displacement due to rotation or translation of the base of the reactor building.

Hydrodynamic Effect

Based upon experience with other drywell structures, the resulting effect of hydrodynamics is to reduce the total seismic forces. Because of this, the effects of the dynamic response of the fluid in the drywell are conservatively neglected in this seismic analysis.

RECOMMENDATIONS

The subject drywell should be designed on the basis of the results presented herein. The final design of the drywell should be reviewed for

twice the design parameters presented herein. In addition to the horizontal acceleration presented herein, a vertical acceleration of 0.04 gravity acting simultaneously with the horizontal acceleration is recommended for design, and twice this value is recommended in evaluating the ability of the plant to safely shut down.

Critical pieces of equipment which are not rigidly attached to the drywell should not be designed on the basis of the results presented herein, but should be investigated separately to determine the effect of the interaction of the equipment and drywell.

MONTICELLO NUCLEAR GENERATION PLANT
EARTHQUAKE ANALYSIS OF DRYWELL

REFERENCES

1. Monticello Nuclear Generation Plant Recommended Earthquake Criteria, John A. Blume & Associates, Engineers, July 15, 1966.
2. Monticello Nuclear Generation Plant Earthquake Analysis, Reactor Building, John A. Blume & Associates, Engineers, July 18, 1967.
3. Drawings
 - a. G. E. Dwg. No. 719 E 147
 - b. C.B.I. Calculation Sheets, dated 9-2-66.
4. Use of Modern Computers in Structural Analysis, by R. W. Clough, Journal of the Structural Division of the American Society of Civil Engineers, ST 3, May 1958.
5. Structural Analysis of Multistory Buildings, by R. W. Clough, Ian P. King and Edward L. Wilson, Journal of the Structural Division of the American Society of Civil Engineers, ST 3, June 1964.
6. Dynamic Effects of Earthquakes, by R. W. Clough, Transaction of the American Society of Civil Engineers, Paper No. 3252.
7. Large Capacity Multistory Frame Analysis Programs, by R. W. Clough, Edward L. Wilson and Ian P. King, Journal of the American Society of Civil Engineers, ST 4, August 1963.

APPENDIX

DATA AND DESIGN FIGURES

MONTICELLO NUCLEAR GENERATION PLANT
EARTHQUAKE ANALYSIS OF DRYWELL

LIST OF FIGURES

	<u>Sheet No.</u>
Geometric Figure	1
Mathematical Model	2
Lumped Masses and Section Properties	3
Earthquake in East-West Direction	
Acceleration Diagram	4
Shear Diagram	5
Moment Diagram	6
Displacement Diagram	7
Earthquake in North-South Direction	
Acceleration Diagram	8
Shear Diagram	9
Moment Diagram	10
Displacement Diagram	11
Maximum Drywell Displacement Diagram	
Relative to Reactor Building	12

JOHN A. BLUME AND ASSOCIATES, ENGINEERS
MONTICELLO DRYWELL
SEISMIC ANALYSIS
GEOMETRIC FIGURE

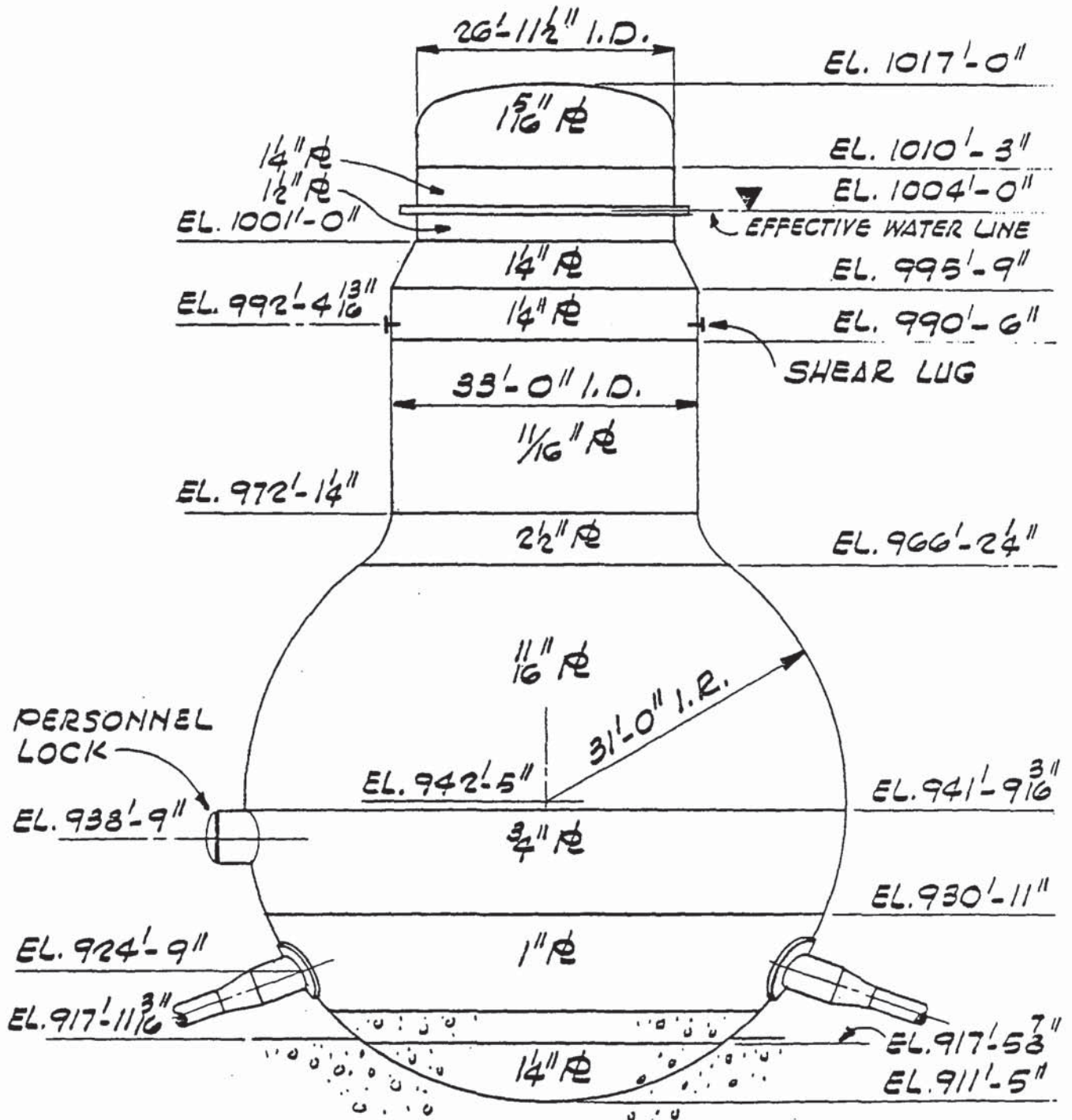

JOHN A. BLUME AND ASSOCIATES, ENGINEERS
MONTICELLO DRYWELL
SEISMIC ANALYSIS
MATHEMATICAL MODEL

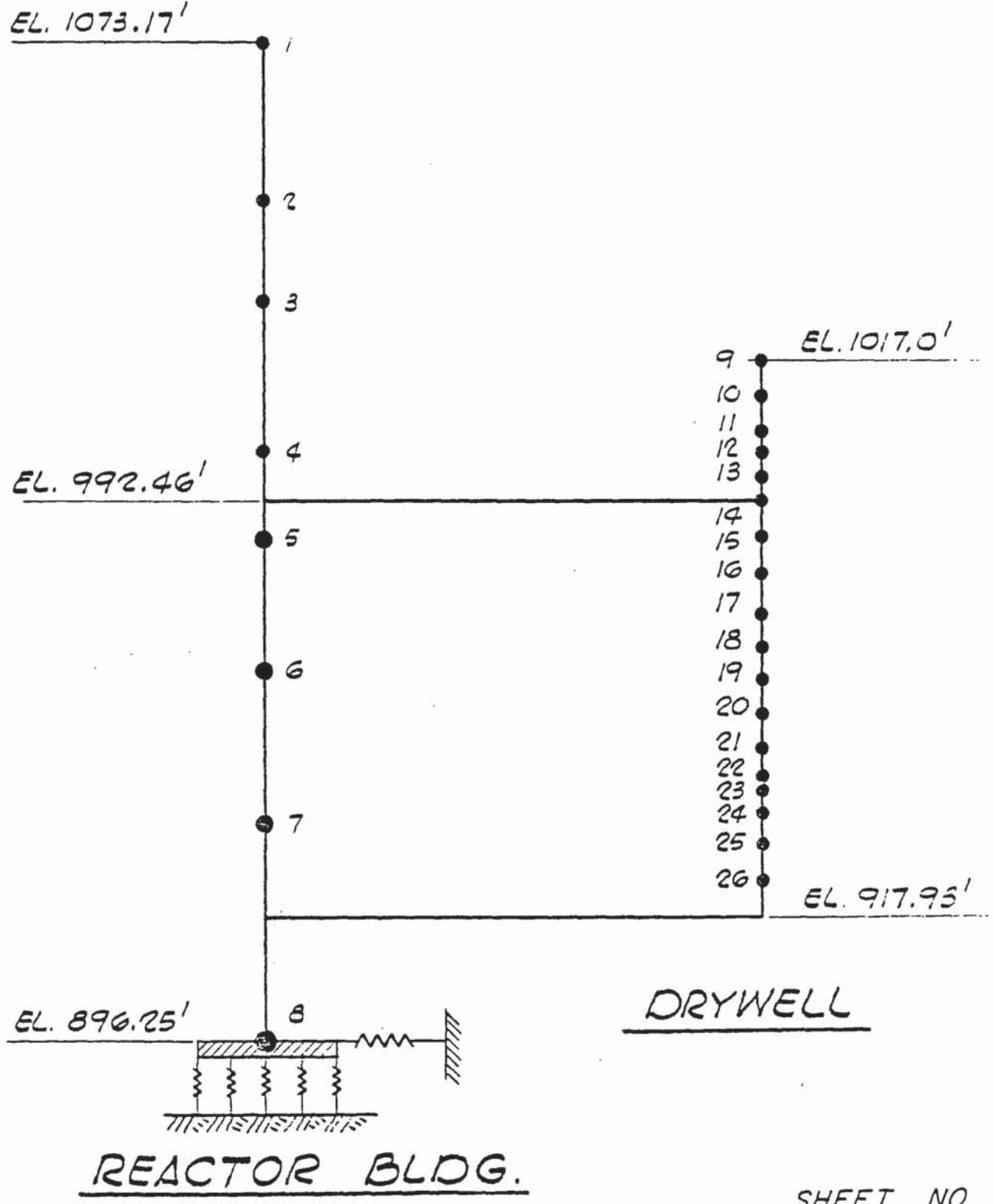

JOHN A. BLUME AND ASSOCIATES, ENGINEERS
MONTICELLO DRYWELL
SEISMIC ANALYSIS
LUMPED MASSES &
SECTION PROPERTIES

		MASS ($\frac{K-SEC.^2}{FT.}$)		LENGTH (FT.)	I (FT. ⁴)	A (FT. ²)
		EMPTY CASE	FULL CASE			
ELEV. 1017.0'	9	0.92	0.92			
	10	1.20	1.20	6.75	851.8	9.29
	11	2.42	2.67	6.25	310.3	3.35
	12	0.72	1.76	3.00	974.6	10.63
	13	0.77	3.47	5.25	1113.1	9.34
ELEV. 992.46'	14	1.46	5.11	3.29	1483.3	10.35
	15	0.60	5.50	6.79	750.0	5.49
	16	0.60	5.50	6.79	750.0	5.49
	17	1.63	6.03	6.78	750.0	5.49
	18	2.02	10.60	5.91	4046.5	23.72
	19	1.06	18.66	5.94	2330.0	8.49
	20	1.40	25.39	5.94	2792.0	9.93
	21	1.66	29.62	5.94	4818.5	10.76
	22	0.59	16.76	5.95	5326.0	11.13
	23	0.58	15.44	0.65	5372.0	11.16
				5.43	5712.0	12.08
	24	1.20	26.54	5.42	5063.0	11.59
	25	1.51	25.92	6.49	5061.0	14.03
ELEV. 917.93'	26	1.68	24.41	6.50	2736.0	11.36

JOHN A. BLUME AND ASSOCIATES, ENGINEERS
MONTICELLO DRYWELL
SEISMIC ANALYSIS
ACCELERATION DIAGRAM
E-W DIRECTION

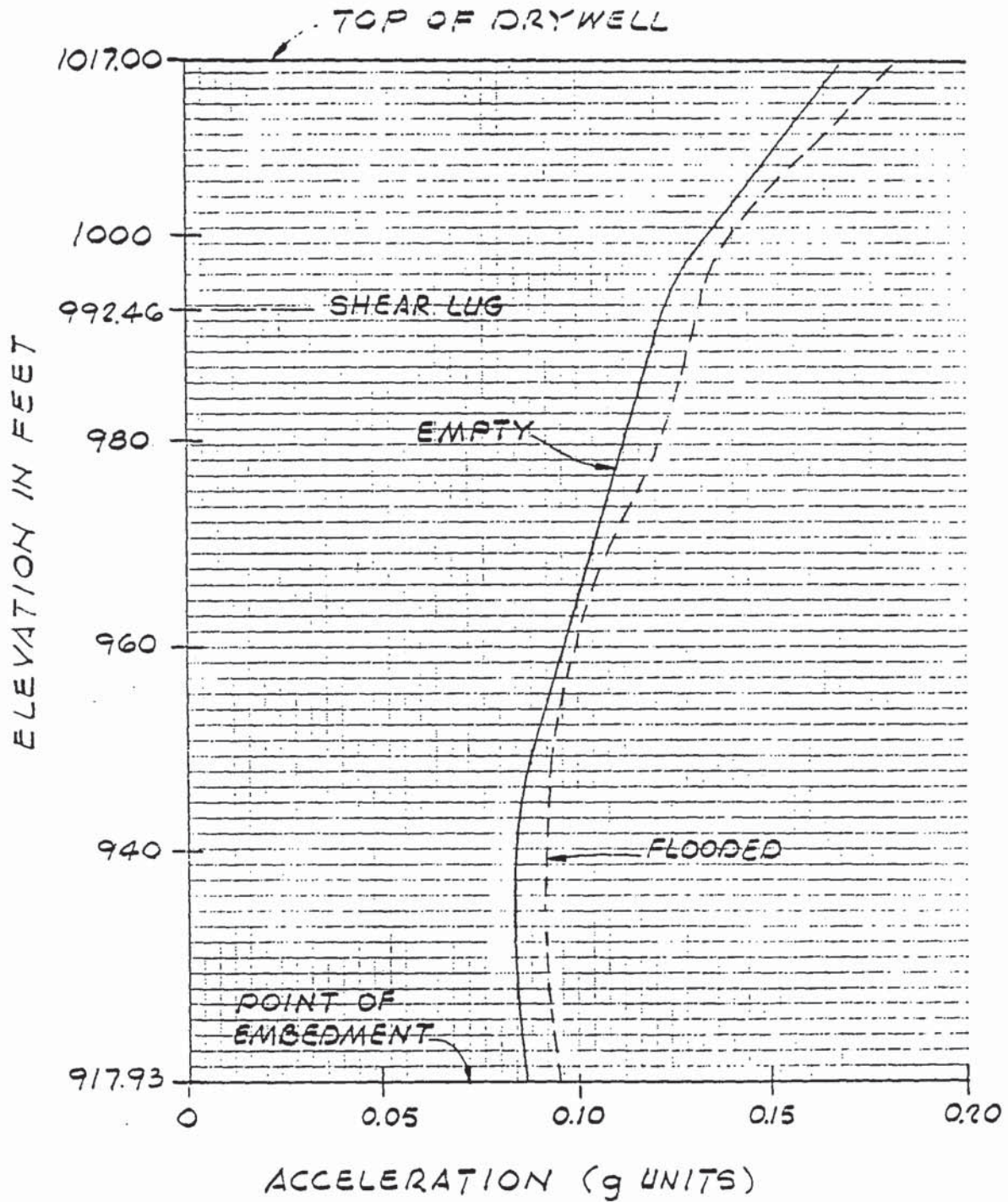

JOHN A. BLUME AND ASSOCIATES, ENGINEERS
MONTICELLO DRYWELL
SEISMIC ANALYSIS
SHEAR DIAGRAM
E-W DIRECTION

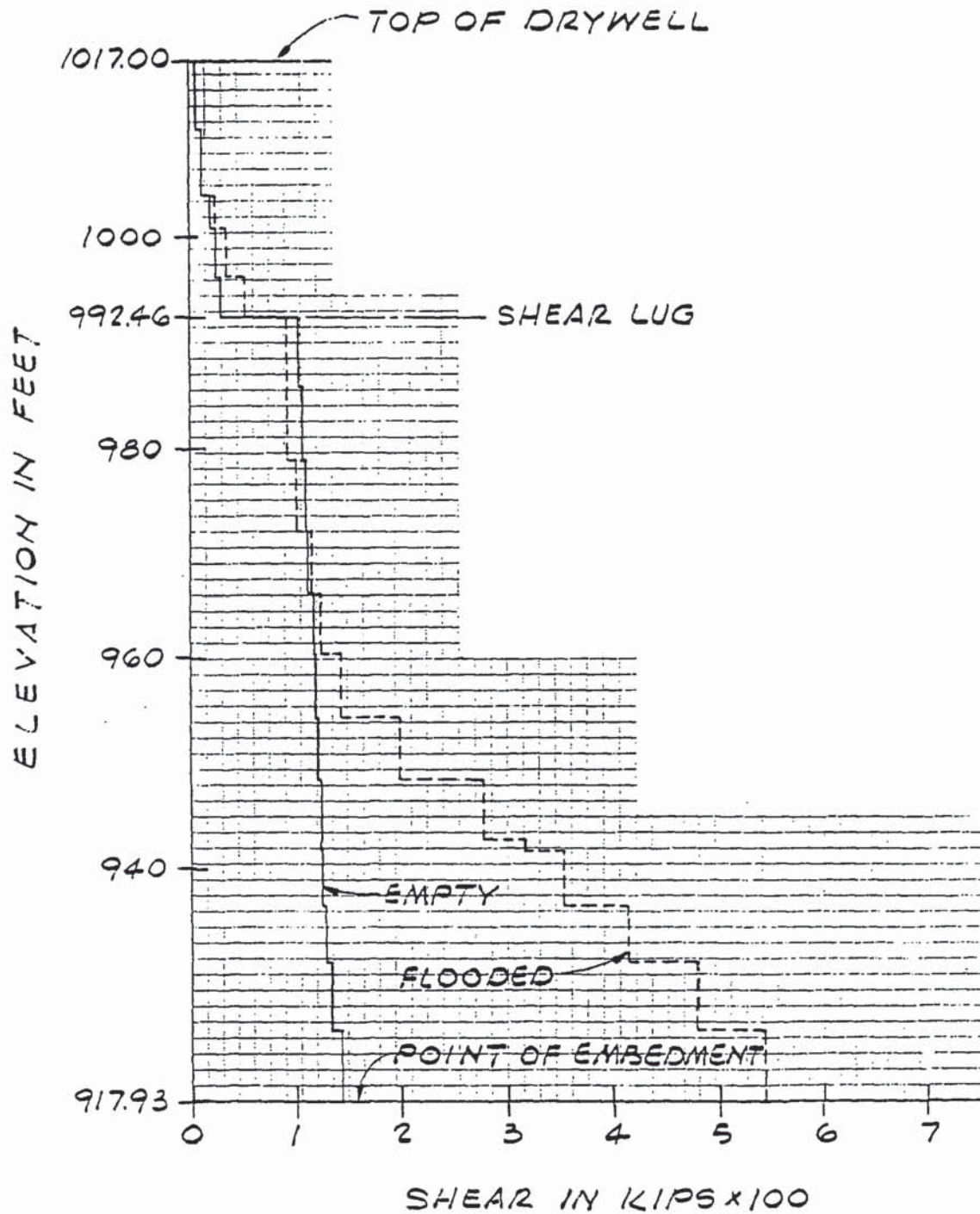

JOHN A. BLUME AND ASSOCIATES, ENGINEERS
MONTICELLO DRYWELL
SEISMIC ANALYSIS
MOMENT DIAGRAM
E-W DIRECTION

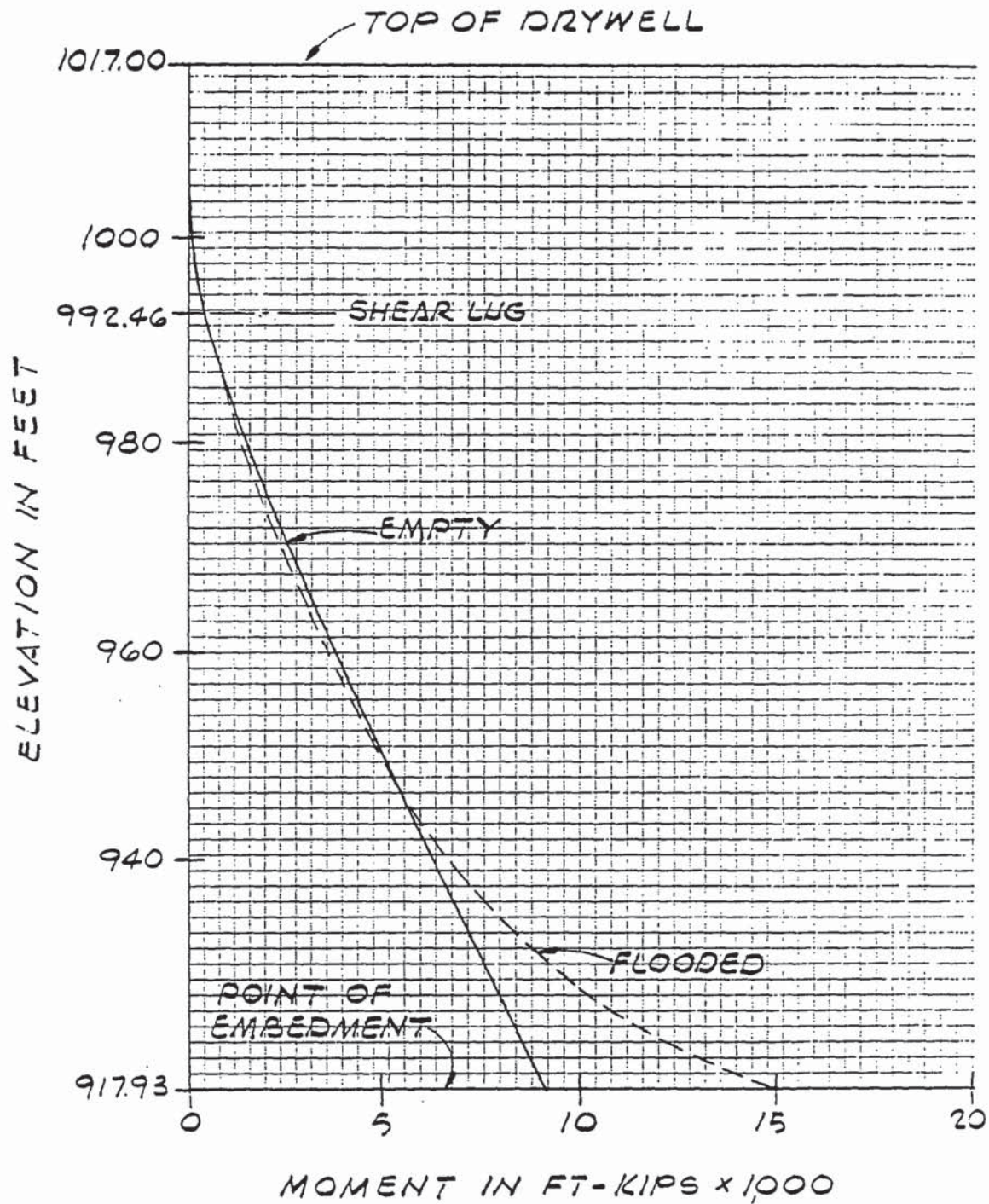

JOHN A. BLUME AND ASSOCIATES, ENGINEERS
MONTICELLO DRYWELL
SEISMIC ANALYSIS
DISPLACEMENT DIAGRAM
E-W DIRECTION

