

DISTRIBUTION AFTER ISSUANCE OF OPERATING LICENSE

NRC FORM 195  
(2-76)

U.S. NUCLEAR REGULATORY COMMISSION

DOCKET NUMBER

50-269/270/287

FILE NUMBER

NRC DISTRIBUTION FOR PART 50 DOCKET MATERIAL

TO: Mr. Edson G. Case

FROM: Duke Power Co.  
Charlotte, N. C. 28242  
William O. Parker, Jr.

DATE OF DOCUMENT

09/24/77

DATE RECEIVED

09/27/77

LETTER  
 ORIGINAL  
 COPY

NOTORIZED  
 UNCLASSIFIED

PROP

INPUT FORM

NUMBER OF COPIES RECEIVED

1 Signed

DESCRIPTION

1p

PLANT NAME: OCONEE UNITS 1 & 2

jcm 09/28/77

ENCLOSURE Consists of status report describing the results of recent tests and examinations which have been performed on Units 1 & 2 regarding steam generator tube leaks...

13p

1 cy Encl Rec'd \*

SAFETY

FOR ACTION/INFORMATION

BRANCH CHIEF: (7)

Schwenger

INTERNAL DISTRIBUTION

REG FILE (3)

~~NRC-PDR~~

I & E (2)

OELD

HANAUER

CHECK

STELLO

EISENHUT

SHAO

BAER

BUTLER

GRIMES

J. COLLINS

EXTERNAL DISTRIBUTION

CONTROL NUMBER

LPDR: WALHAHA, SC

TIC

NSIC

16 CYS ACRS SENT CATEGORY B

492710120

REGULATORY DOCKET FILE COPY  
DUKE POWER COMPANY

POWER BUILDING  
422 SOUTH CHURCH STREET, CHARLOTTE, N. C. 28242

WILLIAM O. PARKER, JR.  
VICE PRESIDENT  
STEAM PRODUCTION

TELEPHONE: AREA 704  
373-4083

September 24, 1977

Mr. Edson G. Case, Acting Director  
Office of Nuclear Reactor Regulation  
U. S. Nuclear Regulatory Commission  
Washington, D. C. 20555

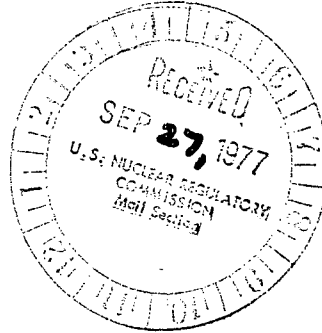

Re: Oconee Nuclear Station  
Docket Nos. 50-269, -270, -287

Dear Mr. Case:

Pursuant to agreements made with members of your staff concerning the Oconee Nuclear Station steam generator tube leaks, the attached status report describes the results of recent tests and examinations which have been performed on Oconee 1 and 2.

Very truly yours,

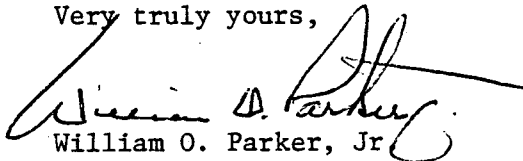
  
William O. Parker, Jr.

MST:vr

Attachment

772710120

OCONEE NUCLEAR STATION  
STEAM GENERATOR TUBE LEAK  
STATUS REPORT

September 24, 1977

In recent months a problem has been identified with regard to the Oconee Nuclear Station steam generator tube leaks. This has been discussed with the NRC staff in meetings on February 15, May 13 and September 20, 1977. A safety assessment of potential consequences and probability of steam generator tube leaks concurrent with MSLB or LOCA was provided in August, 1977. A status report of those investigations performed and future plans for resolution of the steam generator tube leaks was also provided on August 26, 1977.

Previously, based upon information revealed from the behavior of the leaks, results of eddy current testing, visual examinations performed with fiber-optics equipment, and metallurgical analyses of five removed tubes, the leaks had been determined to be caused by the propagation of local defects by high cycle fatigue vibration. The leaks occurred predominately (eight of ten) along an open row of tubes (row 76) at either the 15th tube support plate or the upper tube sheet. This was considered to be due to the steam flow causing greater vibration in these areas. Large amplitude vibrations could also occur from temporary flow increases during turbine stop valve tests which had been performed daily since mid 1975. No information exists concerning the mechanism of the two off-lane leaks. These two leaks occurred at the 14th tube support plate and visual inspections were not performed. It was assumed at the time that these leaks were of the same mechanism (circumferential cracks).

Chemical analyses, visual inspections and metallurgical analyses have confirmed that there is no evidence of intergranular stress corrosion nor is there any evidence of chemical attack.

The Status Report submitted in August, 1977 described the results of these investigations. The plans for future investigations were provided in Section 4.0 of that report. The following updates the Status Report with information recently acquired as a result of further investigations.

In June and July, 1977 during the Oconee 2 refueling outage inservice inspection examinations were performed on both the 2A and 2B steam generators in accordance with the methods outlined in Regulatory Guide 1.83, Revision 1. The number of samples, sample size and results are listed in Table 1. It should be noted that a sample size of 3 percent corresponds to 3 percent of one steam generator or approximately 450 tubes. In consideration of the known situation along the open tube lane the results of this inspection were not particularly surprising. Also, since only one steam generator tube leak had occurred on Unit 2, it was considered that this unit's steam generator tubes would probably have the least defects and an extensive eddy current program was not planned.

During the Unit 2 outage, the installation of a considerable amount of instrumentation was accomplished to aid in the investigation of any tube vibration

phenomena. This unit was chosen because it would provide the earliest possible results due to scheduled outages and would result in less occupational exposure than would Unit 1. The instrumentation installed is summarized in Table 2. Following this installation, data was gathered at steady-state operation at various power levels and during a turbine stop valve test using the original procedure at 96 percent full power. This test closes one stop valve at a time slowly with a rapid closure the last inch of travel. Data was also gathered during three reactor coolant pump operation in which the B steam generator steam flow was 108-110 percent of full power flow. A stop valve test was also performed at 65 percent full power using a new stop valve testing circuitry which simultaneously closes one stop valve on each steam generator and eliminates the rapid closure at the last inch of travel. The data from these tests is currently being evaluated.

The Status Report described an aggressive eddy current inspection program for the Oconee 1 refueling outage which began in early August, 1977. It was initially planned to examine 7 percent of the tubes in each steam generator to statistically determine their condition. This inspection examined the open tube lane and adjacent tubes. Additionally, a pattern of examinations was distributed in a 3 percent totally random and 2½ percent random in the peripheral region fashion. Although five defective tubes (eddy current indication of greater than 40 percent through wall) were identified in the 1B generator and three defective tubes were identified in the 1A generator, none were along the open tube lane. These defects were in the peripheral region and were predominately at the 14th support plate elevation.

As a result of these indications identified in the periphery, a second sample was taken consisting of 3 percent of each steam generator concentrating in the areas around the defects and randomly in the peripheral regions. The results of this inspection revealed one and ten defective tubes in the A and B steam generators, respectively. However, the majority of the defects in the B steam generator were in the two quadrants (WX-XY) which have the steam outlet lines (see Figure 1). Another 6 percent sample was examined in the B generator to more fully examine this region and 10 more defective tubes were identified.

This information indicated that the majority of the defects were located in the periphery of quadrants WX-XY of the B steam generator. However, in an effort to validate this conclusion a 6 percent sample was examined in the WX-XY quadrant periphery of the 1A generator and a 6 percent sample was examined in the YZ-ZW quadrant periphery of the B generator. These samples revealed only one and two defective tubes, respectively, and tended to confirm these conclusions.

Due to the large number of defective eddy current indications, some of which indicated 90%-100% through wall, it was considered essential to obtain tube samples from the periphery for examination. A technique was developed and two tubes were removed and visually inspected on site, with detailed metallurgical analyses to be performed at a later date. The first tube removed was 43/108 which had an eddy current indication of 45-50% through wall at just above the 14th support plate. A visual inspection revealed an eroded area 1/8 inch long and 1/16 inch wide approximately .020 inches deep.

The second tube removed was 83/117 which had an eddy current indication of 80-90% through wall. This tube had erosion wear along a greater area approximately 1 inch long but appeared only to be about 0.010 inches deep. It appeared that the relatively large area of these defects caused the eddy current interpretation to be significantly overestimated. A diagram of these two defects is provided in Figure 2.

As a result of these investigations, it was concluded that the current tube degradation indications were of a different nature than those previously observed in the Oconee steam generators. The majority of the affected tubes appeared to be on the periphery of the B steam generator in the WX-XY quadrants at the 14th tube support plate elevations. The defects appeared to be the result of localized erosion or cavitation mechanisms. These areas of erosion do not appear to be the initiation site for circumferential cracks observed on the open tube lane. The postulated leak mechanism for these tubes would be a through wall pin hole which would not propagate by cracking and which would be easily detectable through the normal leak detection means. It is considered that these tubes would maintain their structural integrity in a main steam line break or loss of coolant accident.

In an effort to improve the Oconee 1 reliability, additional eddy current inspections were performed. These consisted of inspecting all accessible tubes in the 1B steam generator periphery in quadrants WX-XY. Thus, essentially all tubes in periphery of quadrants WX-XY and one-third of the tubes in the YZ-ZW quadrants of the B steam generator have been examined. All tubes with indications greater than 40 percent through wall will be plugged. Tables 3 and 4 summarize those inspections performed and Table 5 summarizes those defective and degraded tubes identified.

This eddy current inspection included examination of four tubes with 14th tube support plate indications which had previously been eddy current tested about four months ago. Of these, three showed no change in defect size while the fourth had grown from less than 20 percent wall thickness to a 35% OD indication. The defect growth mechanism, therefore, appears not to be rapid and may be quantitized in future refueling outage examinations.

Preliminary B&W tube rupture data has demonstrated that a tube with a flat defect 70 percent through the tube wall will not fail under 5,000 psi internal pressure. This is more than twice the pressure which would occur during a postulated MSLB accident. Consequently, a defect would have to grow to greater than 70 percent of the wall thickness before a leak could occur. Examinations of the defects indicate that a pin hole leak would result rather than a crack. Furthermore, these indications are in a region of low cross flow so it is not expected that the hole would develop into a crack. Considering the evidence and the available growth data, it is highly unlikely that a defect could grow large enough before the next scheduled outage that a failure would occur during a postulated MSLB accident.

In the safety assessment report (submitted by letter dated September 9, 1977), the impact of two concurrent events: the double-ended rupture of ten OTSG tubes and a MSLB accident. The double-ended rupture assumption is extremely conservative since, based on the observation of existing failed specimens, the maximum anticipated effect of a MSLB accident on a leaking OTSG tube will be

to marginally increase the leak area without severance of the tube, such that some flow through the tube would be maintained even after the MSLBA. This assumption is even more conservative when applied to partially degraded, but not yet leaking tubes. The double-ended rupture assumption obviously simulates the leak rate of a much larger number of tubes than the ten assumed.

The safety analysis shows that for the guillotine failure of ten tubes, a calculated leak rate of 480 lbm/sec (4650 gpm) results. Detailed dynamic loop analyses and DNBR calculations indicate that no fuel is expected to fail and no return to power (criticality) will be experienced. The core remains covered throughout the transient and ample emergency injection water is available well beyond the termination of the accident. The dose consequences of the double-ended failure of ten OTSG tubes in conjunction with a MSLB accident are less than 5 percent of the 10CFR100 limits. Because the actual leak rate during a MSLB accident will be much less than the 4650 gpm assumed in the safety report, the operation of the Oconee units does not cause a significant health and safety risk to the public.

The steam generator tube investigations described in the August 26, 1977 status report are continuing. The results of recent tests and inspections will be incorporated as necessary to adapt the program to the possible new phenomenon which has been identified. Periodic status reports will be provided to the NRC as information becomes available. In accordance with agreements made in the September 20, 1977 meeting with the staff, the following commitments are made:

1. Information will be provided in a subsequent status report on the metallurgical examination conducted on removed tubes 43/108 and 83/117. This information is expected to be available by December 15, 1977.
2. Evaluations will be performed to evaluate a plugging limit criteria for defective tubes.
3. An attempt will be made to develop an inservice inspection calibration standard which will permit a more realistic, less conservative evaluation of large-area, shallow defects.
4. An attempt will be made to determine the rate of growth, if any, of indications at the 14th support plate at future Oconee 1 outages.
5. At the next Oconee 1 outage, additional peripheral tubes will be examined consistent with critical path scheduling.
6. Technical Specifications concerning inservice inspection of steam generator tubing will be reevaluated, and resubmitted if necessary, to incorporate the most recent experience.
7. Information will be provided in the near future concerning the visual examination of previously leaking, stabilized tube 114/109.

TABLE 1  
 OCONEE 2 INSERVICE INSPECTION  
 JUNE - JULY, 1977

GENERATOR 2A

<u>Sample</u>	<u>Size</u>	<u>Location</u>	<u>Results</u>
1	3%	Random and Open Lane	No Defects

GENERATOR 2B

1	3%	Random and Open Lane	4 Tubes
2	3%	Periphery and Around Defects	No Defects

<u>Defects</u>	<u>Location</u>	<u>Indication</u>	<u>Corrective Action</u>
75/5	15th	85%	Stabilized
75/9	15th	60%	Removed
112/29	12th	30-45%	Plugged
78/2	15th	Unusual Indication	Stabilized

TABLE 2  
 OCONEE UNIT 2  
 VIBRATION TEST PROGRAM  
 SENSORS

I Internal Accelerometers

<u>Location</u>	<u>Row Number</u>	<u>Tube Number</u>	<u>Description</u>
1	77	4	Lane
2	77	18	Lane
3	77	19	Lane
4	77	21	Stabilizer
5	78	4	Off-Lane
6	75	21	Stabilizer

II Pressure Transducers

1. Between shroud and tube bundle in radial direction
2. Between shroud and shell in vertical direction

III Steam Flow

1. Two differential between 1-inch upper high level sensing connections and 1-1/2 inch Steam Annulus Drain Connection.
2. Absolute transducer at upper high level sensing connection of each generator.

IV External Sensors

1. Fourteen accelerometers on auxiliary feedwater nozzle, main feedwater nozzle, main steam line, hot leg and axial on OBG.

V Television Camera

Along open tube lane of B steam generator.



TABLE 3  
 OCONEE 1 INSERVICE INSPECTIONS  
 AUGUST - SEPTEMBER, 1977

GENERATOR 1A

<u>Sample</u>	<u>Size</u>	<u>Location of Sample</u>	<u>Results</u>
1	7%	Open Lane and Adjacent Totally Random Random Periphery	3
		1½% 3% 2½%	
2	3%	Random Periphery and Around Defects	1
3	6%	Random Periphery WX XY	1
TOTAL	16%		

TABLE 4  
 OCONEE 1 INSERVICE INSPECTIONS  
 AUGUST - SEPTEMBER, 1977

GENERATOR 1B

<u>Sample</u>	<u>Size</u>	<u>Location of Sample</u>	<u>Results</u>
1	7%	Open Lane and Adjacent Totally Random Random Periphery	5
		1½% 3% 2½%	
2	3%	Random Periphery and Around Defects	10
3	6%	Periphery WX XY	10
4	6%	Random Periphery YZ ZW Quad.	2
5	<u>11%</u>	All Tubes Periphery WX XY Quad	5
TOTAL	33%		

TABLE 5  
SUMMARY OF OCONEE 1 INSERVICE EXAMINATIONS  
AUGUST - SEPTEMBER, 1977

Defect is at the upper edge of the support plate indicated unless otherwise stated.

OTSG 1B INDICATIONS GREATER THAN 40%

<u>Tube Number</u>	<u>Elevation (Support Plate)</u>	<u>% Through Wall</u>
88 - 122	Center of 9	90 - 100
68 - 127	14	50 - 60
75 - 121	½" above 12	35 - 45
76 - 122	12	55 - 65
43 - 108	14	45 - 50
41 - 110	14	45 - 50
16 - 71	14	70 - 75
17 - 79	13	55 - 60
60 - 127	14	45 - 55
61 - 123	14	65 - 70
64 - 125	14	35 - 40
37 - 4	½" above 14	50 - 60
8 - 49	14	60
60 - 114	1" above 12	45 - 50
100 - 122	13	45 - 50
75 - 113	14	50 - 60
9 - 51	12	80 - 85
8 - 48	14	90 - 100
76 - 111	14	90 - 100
83 - 117	14	80 - 90
99 - 125	14	40 - 50
100 - 124	14	45 - 55
101 - 120	14	45 - 55
101 - 122	14	70 - 75
93 - 110	14	35 - 45
62 - 11	14	40 - 50
61 - 12	14	85 - 95
7 - 32	Between 12 & 13	55 - 65
7 - 53	11	35 - 45
133 - 56	11	95 - 100
138 - 68	-	Movable Obstruction
51 - 123	14	45 - 55
68 - 131	14	60 - 70

OTSG 1B INDICATIONS LESS THAN 40%

<u>Tube Number</u>	<u>Elevation (Support Plate)</u>	<u>% Through Wall</u>
6 - 43	14	30 - 40
101 - 121	14	35 - 40
7 - 53	11	25 - 30

TABLE 5 (Cont'd)

<u>Tube Number</u>	<u>Elevation (Support Plate)</u>	<u>% Through Wall</u>
7 - 54	14	25 - 30
12 - 68	13	30 - 35
98 - 125	1" above 14	30 - 35
26 - 6	12	25 - 30
17 - 80	14	20 - 30
22 - 90	14	25 - 30
55 - 124	¼" below upper edge 14	25 - 30
78 - 126	Center of 9	30
40 - 110	½" above 14	30 - 35
52 - 117	12	25 - 35
44 - 109	14	25 - 30
54 - 2	11	20
61 - 110	12	25 - 30
90 - 125	12	30 - 40
90 - 124	14	25 - 30
92 - 117	Between 8 and 9	30
93 - 119	10	25 - 30
110 - 111	Lower edge 10	20 - 30
113 - 112	Lower edge 14	25 - 30
85 - 126	14	15 - 25
85 - 127	¼" above 14 (short long.)	25 - 35
86 - 127	14	25 - 35
50 - 121	14	25 - 30
76 - 119	14	25 - 30
143 - 5	11	25 - 35
62 - 10	14	25 - 35
8 - 45	14	30 - 35
3 - 24	14	20 - 30
6 - 32	14	15 - 25
7 - 54	14	20 - 30
35 - 107	4	20 - 25
35 - 91	12	15 - 25
150 - 16	7	15 - 25
139 - 69	7	20 - 30
134 - 82	10	20 - 30
124 - 101	9	20 - 30
90 - 129	11	20 - 30
55 - 125	14	20 - 30
53 - 125	12	25 - 35
6 - 51	14	15 - 25
18 - 85	10	30 - 40

OTSG 1A INDICATIONS GREATER THAN 40%

<u>Tube Number</u>	<u>Elevation (Support Plate)</u>	<u>% Through Wall</u>
8 - 5	14	45 - 50
117 - 107	14	40 - 50
146 - 14	14	50 - 60
147 - 11	14	50 - 60
7 - 4	14	50 - 60

TABLE 5 (Cont'd)

OTSG 1A INDICATIONS LESS THAN 40%

<u>Tube Number</u>	<u>Elevation (Support Plate)</u>	<u>% Through Wall</u>
78 - 22	4	15 - 25
75 - 9	15	15 - 25 & 25 - 35
75 - 21	¼" below 15	15 - 25
75 - 26	¼" below 15	15 - 25
72 - 128	14	25 - 35
4 - 14	14	20 - 30
6 - 3	14	Uninterp.
9 - 7	14	25 - 35

FIGURE 1

TOP OF UPPER TUBE SHEET

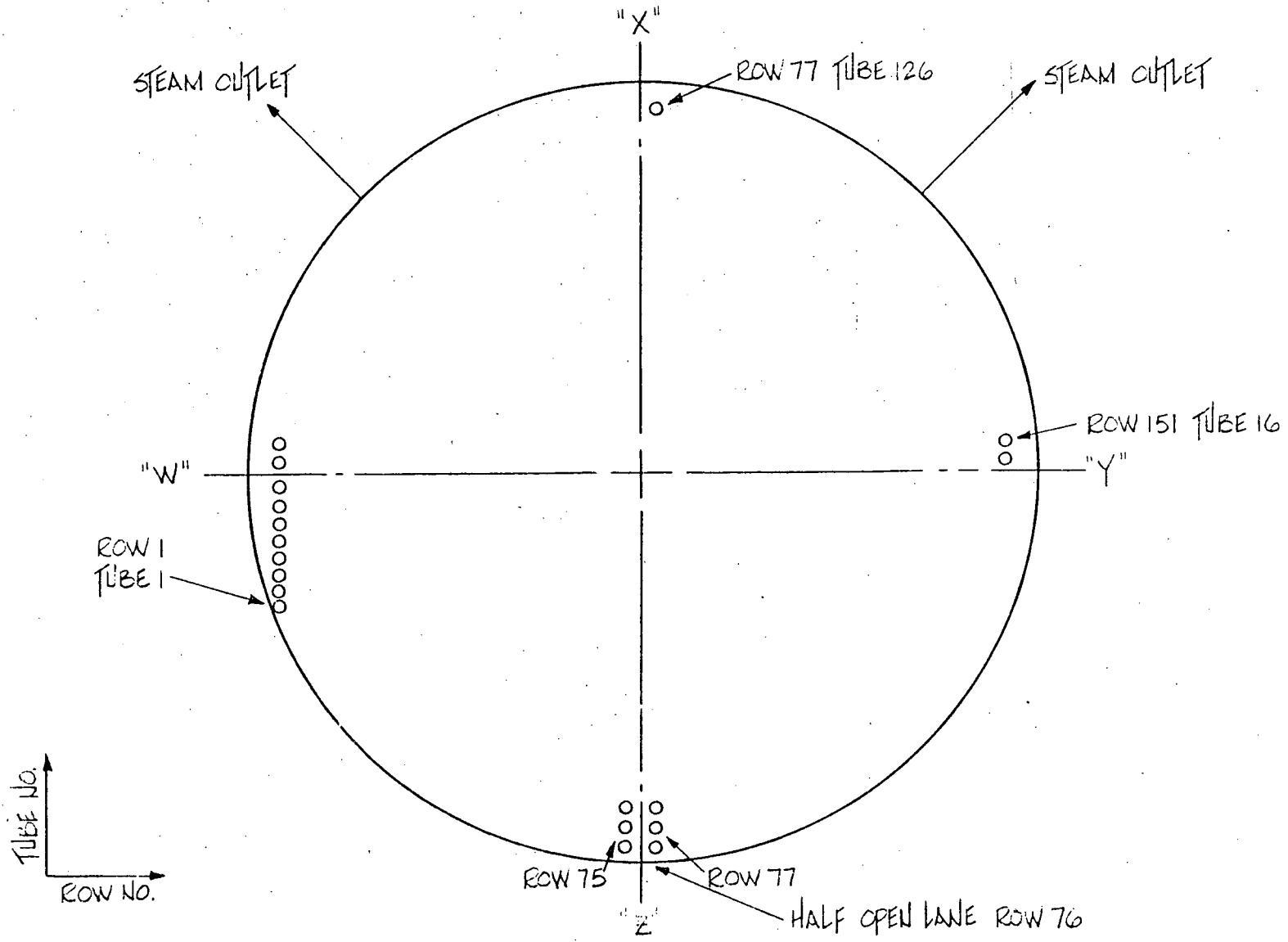

FIGURE 2

