



W. Grover Hettel
Columbia Generating Station
P.O. Box 968, PE23
Richland, WA 99352-0968
Ph. 509.377.8311 | F. 509.377.4150
wghettel@energy-northwest.com

December 22, 2015
GO2-15-179

U.S. Nuclear Regulatory Commission
ATTN: Document Control Desk
Washington, D.C. 20555-0001

Subject: COLUMBIA GENERATING STATION, DOCKET NO. 50-397 RESPONSE TO INSPECTION REPORT 05000397/2015003

References: Letter dated November 12, 2015, TW Pruett (NRC) to ME Reddemann (Energy Northwest), "Columbia Generating Station – NRC Integrated Inspection Report 05000397/2015003 and Exercise of Enforcement Discretion"

Letter dated December 11, 2015, WG Hettel (Energy Northwest) to NRC, "Columbia Generating Station, Docket No. 50-397; Request for Extension to Respond to the November 12, 2015 NRC Integrated Inspection Report (EA-15-202)"

Dear Sir or Madam:

The purpose of this letter is to provide Energy Northwest's response to the Non-Cited Violation (NCV) of 10 CFR 50, Appendix B, Criterion III, "Design Control," related to the verification of the adequacy of the design of the Control Room Heating, Ventilation, and Air Conditioning system as documented in the referenced inspection report. Energy Northwest respectfully disagrees with the NCV as it pertains to the requirement for a transient analysis for control room operator comfort levels.

The attachment to this letter contains a restatement of the NCV and provides Energy Northwest's response to the NCV. Should you have any questions or desire additional information regarding this letter, please call DM Wolfgramm at (509) 377-4792.

Respectfully,



WG Hettel
Vice President Operations

Attachment: Response to Non-Cited Violation

cc: ML Dapas - NRC RIV
BK Singal - NRC NRR
CD Sonoda – BPA

Director, Office of Enforcement – NRC
NRC Senior Resident Inspector
WA Horin -Winston & Strawn

RESPONSE TO NON-CITED VIOLATION

Attachment

Page 1 of 17

A. Introduction

As discussed herein, Energy Northwest submits that the NRC position as stated in the Inspection Report:

Specifically, the licensee failed to demonstrate the ability of control room HVAC design to maintain the temperatures in the main control room below habitability and environmental qualification limits, for the duration of all accident scenarios.¹

is neither a requirement applicable to Columbia, nor consistent with the Columbia licensing and design basis² and, as framed, is functionally unachievable without major plant system modifications.

The specific error in the NRC position to which Energy Northwest takes issue relates to the treatment of operator comfort temperature limits as a design basis requirement that will never be exceeded under any accident scenario. For the reasons described herein, Energy Northwest submits that there is no basis for that NRC position.

The program by which Energy Northwest provides assurance of control room habitability and equipment qualification temperature control has been examined by the NRC on many occasions, over many years and in many contexts. An overview of this program and NRC approvals thereof are summarized in our discussion here. While there have been questions related to the use of 10 CFR 50.59 with respect to some FSAR changes related to temperature limits, it has never been Energy Northwest's position, nor was it ever reflected in an NRC position, that the Columbia design or licensing basis was to "maintain the temperatures in the main control room below habitability and environmental qualification limits, for the duration of all accident scenarios."

Thus, as explained more fully below, Energy Northwest denies the proposed violation.

Further, in the event that the NRC maintains that their description of the design and/or licensing basis of the Control Room Heating, Ventilation, and Air Conditioning (henceforth known as control room HVAC) cooling system is as framed in the Inspection Report, Energy Northwest requests that the NRC conduct a full backfitting analysis pursuant to 10 CFR 50.109. Energy Northwest believes that the analysis will show that not only is this a backfit, i.e., a new staff position that would dictate physical and programmatic plant changes, but that the imposition of such a position would not be justified as an exception to the backfit rule because it is not consistent with NRC requirements and approved licensee implementation of those requirements, and would

¹ Because the NRC frames their concern in varying fashions throughout the Inspection Report, Energy Northwest is interpreting this statement in the "Analysis" section of the IR (p.13), as the summary statement of staff position with this issue.

² The NRC further characterizes their finding as indicating that the "design basis" as stated in the FSAR, was not "ensured."

RESPONSE TO NON-CITED VIOLATION

Attachment

Page 2 of 17

result in additional burdens on Energy Northwest that cannot be justified in light of the already comprehensive control room HVAC program in place at Columbia that has been reviewed and found by the NRC to provide reasonable assurance of the protection of the public health and safety.

B. Restatement of Violation

Inspection Report 05000397/2015003 documented the following NRC identified Non-Cited Violation (NCV).

“The inspectors identified a non-cited violation of 10 CFR 50, Appendix B, Criterion III, “Design Control,” for the licensee’s failure to verify the adequacy of the design of the control room HVAC system. Specifically, the licensee failed to demonstrate the ability of control room HVAC design to maintain the temperatures in the main control room below habitability and environmental qualification limits, for the duration of all accident scenarios.”

C. Energy Northwest Position

Energy Northwest respectfully disagrees with the NCV in regard to requiring a transient analysis associated with control room habitability limits based on the following points which will be discussed in further detail in Section F of this attachment:

1. There are no design basis requirements to maintain the control room temperature at less than or equal to 85°F at all times for all accident scenarios
2. Columbia’s control room HVAC system design was approved with no requirement to have automatic features
3. Columbia’s control room HVAC design has been previously evaluated by the NRC on at least two separate occasions and determined to be adequate
4. Consideration for transient conditions during initial startup of support systems was established after Columbia was licensed.

It is Energy Northwest’s position that compliance with 10 CFR Appendix B Criterion III has been maintained. In addition, the imposition of transient requirements to prevent exceeding a maximum temperature in the control room for operator comfort while realigning cooling sources to the control room HVAC constitutes new Licensing requirements that should be evaluated through the backfit analysis process of 10 CFR 50.109.

RESPONSE TO NON-CITED VIOLATION

Attachment

Page 3 of 17

D. Simplified Description of the control room HVAC System

The control room HVAC System (WMA) consists of two independent, redundant subsystems that provide cooling of recirculated control room air. Each subsystem consists of two cooling coils (one normal and one emergency) to provide for control room temperature control. The normal cooling coil is provided chilled water from a non-emergency chiller.

While there are two cooling coils, only the emergency cooling coil is required in an accident condition. The emergency cooling coil in each division is cooled by either the Emergency Chilled Water (CCH) System or by the Standby Service Water (SW) System in that same division.

The line-up to the emergency cooling coil system utilizes both the Standby Service Water and Emergency Chilled Water System cooling water supply. Normally Division 1 (WMA-AH-51A) is lined up to Standby Service Water and Division 2 (WMA-AH-51B) is aligned to the emergency chilled water system. Both support systems are emergency diesel backed. The emergency cooling coils can be manually realigned to receive cooling from the alternate cooling source as shown in Figure 1 below:

Figure 1 – Simplified Control Room HVAC Cooling

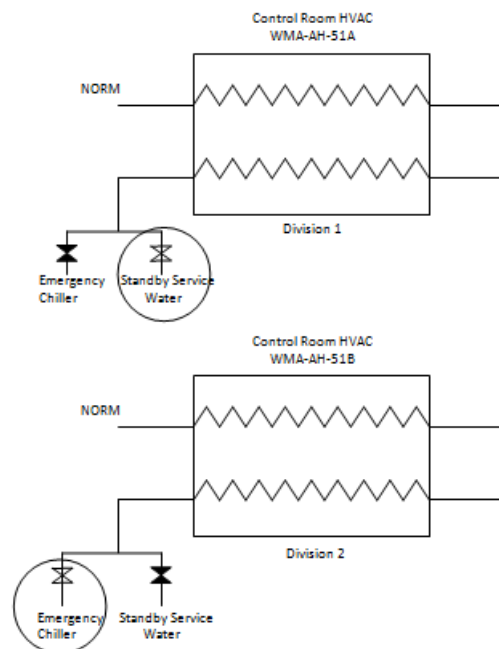

The system is aligned in this configuration because both chillers are located in the same room. In the event of a fire in the Chiller room in which both chillers could be disabled, SW can still provide cooling to the control room to support safe shutdown of the plant.

RESPONSE TO NON-CITED VIOLATION

Attachment

Page 4 of 17

The SW system is designed to provide sufficient cooling at all times for equipment operability/functionality in the control room. During the winter months it is capable to also provide sufficient cooling for Operator comfort. The CCH system is designed to provide sufficient cooling for both functions regardless of the season. Only one division of ventilation is needed to maintain operator comfort and equipment operability in the control room.

The following is a breakdown of postulated accident scenarios and Operator actions necessary to ensure cooling is provided to the control room:

Event	Impact to Control Room Cooling	Operator Action to Restore Cooling
Design Basis Accident (DBA) with no Loss of Offsite Power (LOOP), and no failure affecting WMA system	Both SW and CCH available to provide cooling. SW auto started. CCH on standby and not auto started.	CCH manually started to maintain cooling if SW cannot maintain Operator comfort and equipment operability. (Can be placed in service in minutes)
DBA with LOOP with no additional single failure	SW auto sequenced on diesel to provide cooling. CCH on standby and not auto started. (Operator comfort level may be temporarily exceeded)	If Operator comfort and equipment operability cannot be met with SW then, CCH Chiller would need to be reset by pressing local reset and manually started. (Can be placed in service in <1 hour)
DBA with LOOP and single failure (e.g., loss of power to SW system aligned to WMA)	No immediate cooling to control room (Operator comfort level may be temporarily exceeded)	CCH Chiller would first need to be reset by pressing local reset and then manually started. (Can be placed in service in <1 hour)
DBA with LOOP and single failure (e.g., loss of power to WMA where CCH aligned)	SW auto sequenced on diesel to provide cooling. (Operator comfort level may be temporarily exceeded)	Remaining WMA manually re-aligned to CCH if SW cannot maintain Operator comfort and equipment operability. (Can be placed in service in <1 hour)
Fire in Chiller area (no DBA)	WCH available to provide normal cooling or SW available to provide emergency cooling.	None required. Capability to safely shutdown plant retained.

RESPONSE TO NON-CITED VIOLATION

Attachment

Page 5 of 17

E. Excerpt from Inspection Report

The following excerpts from Inspection report 05000397/2015003 describe the NCV (section headers added):

Description. On July 2, 2015, the inspectors performed a review of the control room HVAC system with a focus on the control room emergency chillers. The Final Safety Analysis Report, Section 9.4.1.1, "Design Basis" states, in part, that the design of the control room HVAC system is such that in an emergency condition, "the control room temperature will be maintained within the habitability limit (85 °F) by the control room chilled water. Service water can maintain the control room temperature limit of 85 °F during colder weather. Service water will maintain the control room within the environmental qualification temperature limit for control room equipment (104 °F)."

The inspectors noted that the vendor manuals for the control room emergency chillers described an automatic trip feature that required local resetting. Specifically, the manufacturer states the following in the "Normal Operating Sequence" section of the manual:

Shutdown where the unit cannot automatically restart...Shutdown on a power failure produces the same results as for a safety shutdown except relay 14R is de-energized...It is necessary to depress the "STOP-RESET" button to energize relay 14R when power is restored after interruption.

The inspectors reviewed relevant electrical diagrams and confirmed that operation of the control room emergency chillers required a local reset of relay 14R following a loss of power. The alignment of the control room HVAC system is such that the division 1 air handling unit, WMA-AH-51A, is aligned to standby service water and the division 2 air handling unit, WMA-AH-51B, is aligned to chill water. Because of the design feature involving the relay 14R and the alignment of the air-handling units, the inspectors identified that:

- 1) Following any event that resulted in a loss of offsite power with a single-failure of the Division 1 emergency diesel generator, the control room would not receive cooling via WMA-AH-51B, the only operable air handling unit, until the local chiller reset pushbutton was depressed. The control room would remain without cooling until this manual reset was accomplished since relay 14R would be de-energized.*
- 2) Following certain events involving a loss of offsite power with a single-failure of the Division 2 emergency diesel generator, the control room would experience reduced, and in some instances, no external cooling. In particular, when ambient conditions would not allow service water alone to maintain the control room below the 85 °F habitability limit, operators would be prompted to secure standby service water cooling to WMA-AH-51A and realign cooling from the control room emergency chillers system. The inspectors noted that during the shift between*

RESPONSE TO NON-CITED VIOLATION

Attachment

Page 6 of 17

standby service water and control room emergency chill water, there would be a brief period when the control room would receive no external cooling.

For each of the above scenarios, temperatures in the control room could exceed 85 °F or 104 °F due to times necessary for system realignment or local resetting manual actions. At the time of the inspection, procedure OI-69, "Time Critical Operator Actions," Revision 5, did not identify any required manual actions associated with local reset or realignment of the control room HVAC system. This procedure defines a time critical action as a manual action, or series of actions that must be completed within a specified time to meet the plant-licensing basis.

The inspectors reviewed calculation ME-02-92-43, "Room Temperature Calculation for DG Building, Reactor Building, Radwaste Building, and Service Water," Revision 10, and noted that this calculation covers the control room air-handling units but only considers steady-state conditions for heat exchanger performance. There is no discussion in ME-02-92-43 for transient scenarios where the control room would receive no external cooling, such as those involving local resetting of control room emergency chillers or during required shifts between standby service water and control room emergency chill water.

The inspectors requested a design analysis that demonstrated the ability of control room HVAC design to maintain the temperatures in the main control room below habitability and environmental qualification limits during these transient situations. The licensee was unable to locate a design verification that demonstrated the ability of the control room HVAC system during transient scenarios following a loss of power and could not determine the peak control room temperature nor the impact to habitability or equipment qualification in these scenarios.

The inspectors reviewed previous inspection reports for the station and noted one related finding: NRC-identified NCV 05000397/2013002-04, "Failure to Obtain NRC Approval for Changes to Control Room HVAC Requirements." This NCV identified an incorrect value for the control room temperature limit and resulted in the current value as found in the licensee's design basis. The inspectors determined that the extent of condition review from this 2013 finding did not adequately consider the effects of lowering a design habitability temperature for the control room from 104 °F to 85 °F, necessitating the need for the control room emergency chillers. Specifically, when evaluating the correct habitability limit of 85 °F, the licensee only considered the steady state cooling needs of the control room and not the transient effects experienced because of the chiller design.

In response to the NRC's conclusions, the licensee initiated Action Request 332565 to document the concern, issued night order 1662 to communicate the issue, aligned both control room air handling units to their respective chillers, created a quick card procedure to perform the chiller reset actions, and validated the quick card actions could be accomplished within 10 minutes. Additionally, the licensee determined that

RESPONSE TO NON-CITED VIOLATION

Attachment

Page 7 of 17

operators could restore the chillers during accident conditions within 90 minutes to prevent temperatures from exceeding equipment operability limits.

Analysis. The failure to provide design control measures to verify the adequacy of the design of the control room emergency chillers was a performance deficiency. The performance deficiency was more than minor because it adversely affected the design control attribute of the Mitigating Systems Cornerstone objective to ensure the availability, reliability, and capability of systems that respond to initiating events to prevent undesirable consequences. Specifically, the licensee failed to demonstrate the ability of control room HVAC design to maintain the temperatures in the main control room below habitability and environmental qualification limits, for the duration of all accident scenarios.

F. Energy Northwest Detailed Response

As stated in Section B of this attachment, Energy Northwest does not agree entirely with the conclusions associated with the NCV and for the reasons described below, denies that NCV. The point of disagreement lies with the assumption that a design basis analysis is required for ensuring the operator comfort limit (85°F) is not exceeded. Energy Northwest disagrees based on the following:

1. **There are no design basis requirements to maintain the control room temperature at less than or equal to 85°F at all times for all accident scenarios**

Supporting details are as follows:

- a. Columbia's current Technical Specifications have no requirement for control room temperature to maintain operator comfort.
- b. Columbia's FSAR does not credit achieving operator comfort levels within a given time period in any safety analysis. The ability to maintain it within comfort levels is implicitly assumed "once" the chilled water is applied to the cooling coils.
 - For example, on March 4, 1997, the NRC acknowledged in the safety evaluation (SE) for License Amendment 149 which converted Columbia's Technical Specification to Improved Technical Specifications (ITS), that the 85°F limit was based on "when" emergency chilled water is supplied to the cooling coils.

When emergency chilled water is supplied to the cooling coils, the control room temperature is maintained at 85°F. This ensures equipment operability while providing cooling capacity for personnel comfort.

RESPONSE TO NON-CITED VIOLATION

Attachment

Page 8 of 17

- c. When Columbia was licensed in December 1983, there were no NRC requirements placed on achieving operator comfort levels by a given time following the onset of a design basis event, thus there would be no requirements for the performance of a transient analysis.
- d. Columbia's control room HVAC design was initially reviewed under NUREG-0800, Revision 2. Guidance specified in revision 2 of NUREG-0800 Section 9.4.1 did not create an expectation of ensuring that the control room temperature never exceeds comfort levels when cooling systems are initially placed in service following a design basis event.
- e. In the original safety evaluation report (SER) for licensing of Columbia, NUREG-0892, the NRC concluded that control room temperatures would be maintained "at or below" 104 °F to maintain equipment operability but the same language (at or below) was not used with regard to operator comfort. Instead the more softer "compatible with" language was provided:

The FSAR states that all three areas are to be maintained at or below 104 °F and that this is acceptable for the equipment in the control room.

In a response to staff concern, the applicant stated that seismic Category I redundant, environmentally qualified water chillers will be provided for the control room HVAC to maintain ambient conditions compatible with the comfort zone as defined by ASHRAE.

- f. The NRC introduced new requirements in the inspection report that did not previously exist with regard to the "duration of all accident scenarios." The following is discussed in the inspection report (emphasis added):

Specifically, the licensee failed to demonstrate the ability of control room HVAC design to maintain the temperatures in the main control room below habitability and environmental qualification limits, for the duration of all accident scenarios.

- The documented language in the inspection report has the presumption that during such conditions as the early stages of a loss of offsite power event, the control room will not exceed, even momentarily, operator comfort levels.
- In order to ensure this presumption would be met under all possible scenarios, Columbia would need to have incorporated auto start and/or auto swap of cooling supply features following a loss of offsite power event that would allow the chiller to sequence on and provide cooling to the non-affected control room ventilation system.

RESPONSE TO NON-CITED VIOLATION

Attachment

Page 9 of 17

- Columbia was never designed for auto starting of a chiller or auto swapping of cooling sources following a loss of offsite power to prevent temporarily exceeding operator comfort limits, nor was that design feature required.
 - As will be discussed later in this response, the NRC has already performed more than one evaluation of Columbia's control room HVAC design and has never identified a requirement to have such a feature.
 - Furthermore, Columbia's Technical Specification LCO 3.7.4 only requires control room HVAC operability in modes 1, 2, 3 and during operations with a potential for draining the reactor vessel. Therefore, the control room HVAC system is not required in all accident scenarios (e.g., fuel handling accident).
- g. NEI 97-04, Appendix B, as endorsed by NRC Regulatory Guide 1.186, describes design basis as consisting of the following:

Design bases functions: Functions performed by systems, structures and components (SSCs) that are (1) required by, or otherwise necessary to comply with, regulations, license conditions, orders or technical specifications, or (2) credited in licensee safety analyses to meet NRC requirements.

The NRC has not established a design basis requirement with regard to achieving operator comfort levels by a given time following a design basis event.

- h. Regarding 10 CFR 50 App B Criterion III, measures are in place at Columbia to provide for verifying or checking the adequacy of design. These include:
- Control room temperature is monitored and documented every 12 hours
 - Control room temperature is maintained 72-78°F during normal operations
 - Control room staff will either notice the rise in temperature immediately or note it during 12 hour monitoring and take actions in accordance with abnormal operating procedures
 - Testing is performed every 24 months in accordance with TS surveillance 3.7.4.1 to verify each control room HVAC subsystem has the capability to remove the assumed heat load
 - Testing of the emergency chillers is performed every 31 days in accordance with Licensee Controlled Specification Surveillance Requirement 1.7.2.1 to demonstrate that the emergency chillers are capable of removing the required heat load from the control room.

RESPONSE TO NON-CITED VIOLATION

Attachment

Page 10 of 17

2. Columbia's control room HVAC system design was approved with no requirement to have automatic features

Supporting details are as follows:

- a. In supplement four of NUREG-0892, SER for Columbia, the NRC acknowledged that the only conditions Energy Northwest agreed to place upon the design for the emergency chillers were Seismic category I, Redundant, and Environmentally qualified. Supplement four of NUREG-0892 states:

"As stated in the SER, the applicant committed to provide seismic Category I, redundant, environmentally qualified water chillers for control room heating, ventilation, and air conditioning (HVAC) systems to maintain ambient conditions compatible with the comfort zone, as defined by the American Society of Heating, Refrigeration, and Air Conditioning Engineers (ASHRAE)."

This was consistent with the original License condition established in Columbia's Operating License:

"Control Room Chillers Installation (Section 9.4.1, SER, SSER #4) The licensee shall have operable before May 31, 1984, redundant, seismic Category I environmentally qualified water chillers for control room HVAC."

The emergency chillers were never required to have auto features nor were they required to be sequenced on following a loss of offsite power to emergency 4.16 kV buses following re-energization on emergency diesel generators.

- b. It is Energy Northwest's position that the phrase "to maintain ambient conditions" is a steady state assumption.
 - As mentioned previously, on March 4, 1997 and described below, the NRC acknowledged in the safety evaluation (SE) for License Amendment 149 that the 85°F limit was based on "when" emergency chilled water is supplied to the cooling coils (emphasis added):

When emergency chilled water is supplied to the cooling coils, the control room temperature is maintained at 85°F. This ensures equipment operability while providing cooling capacity for personnel comfort.
 - In letter Go2-82-080 dated March 2, 1982, Energy Northwest communicated to the NRC that the "cooling coils" were capable of maintaining control room temperatures within design limits. The presumption was that once cooling flow was applied to the cooling coil

RESPONSE TO NON-CITED VIOLATION

Attachment

Page 11 of 17

temperatures could be maintained. The content of this letter is described below (emphasis added)

The Control Room Cooling System consists of two (2) redundant room coolers and chilled water supply systems. Each room cooler has two (2) cooling coils, one for normal operation when Radwaste Building chilled water is available, and one for emergencies when the Control Room chillers supply chilled water. Either emergency cooling coil in either cooler is capable of maintaining the Control Room temperature within design limits.

- c. As a point of comparison, in NUREG-0892, the NRC acknowledged the auto start features for the control room emergency filter (CREF) system which is normally maintained in standby. However, no similar assumptions were made in regard to the emergency chillers which are also kept in standby. Section 6.5.4.1 of NUREG-0892 states the following with regard to the CREF system (emphasis added):

The function of the control room emergency filter system (CREFS) is to supply nonradioactive air to the control room after a DBA and to pressurize the control room. This system will permit operating personnel to remain in the control room following a DBA...The system will be automatically activated by any of the following signals: reactor vessel low water level, high drywell pressure, or high radiation level in the reactor building exhaust ventilation system...Based on the above determinations, the staff finds that the CREFS is designed to adequately control the concentration of radioactive materials in the control room atmosphere in accordance with applicable regulations following a postulated DBA.

- d. Lastly, the NRC acknowledged in the SE of Amendment 149 for removal of the 85°F temperature limits from LCO 3.7.4, that the restoration of systems to assure equipment temperature limits are not exceeded would require operator action. No expectation was established of assuring habitability temperature limits are never exceeded. The following is documented in the SE (emphasis added):

Because the control room air temperature is normally < 78°F and staff are continuously present in the control room, control room personnel will easily detect temperature increases and take corrective action before any equipment temperature limits are reached.

RESPONSE TO NON-CITED VIOLATION

Attachment

Page 12 of 17

3. Columbia's control room HVAC design has been previously evaluated by the NRC on at least two separate occasions and determined to be adequate

Supporting details are as follows:

a. NRC design reviews were conducted and documented in the following:

- NUREG-0892 NRC Safety Evaluation of WNP-2
- NUREG/CR-4960 ANL-87-22, Control Room Habitability Survey of Licensed Commercial Nuclear Power Generating Stations, October 1988.

Neither of these reviews provided conclusions that indicated the design of the system as described in the FSAR was inadequate or that it did not meet design requirements as it relates to operator comfort. No significant design changes have been made to the emergency chilled water systems that would invalidate the conclusions.

b. With regard to NUREG-0892, and as stated below in section 9.4.1. of NUREG-0892, the guidance in NUREG-0800 section 9.4.1 was used for determining acceptance of the main control room HVAC system:

The following sections were reviewed in accordance with SRP Sections 9.4.1, 9.4.2, 9.4.3, 9.4.4 and 9.4.5 (NUREG-0800).

9.4.1 Main Control Room/Cable Spreading Room/Critical Switchgear Area HVAC Systems

- A review of Section 9.4.1 of revision 2 of NUREG-0800 revealed no acceptance criteria related to operator comfort requirements.
- The most relevant requirement relates to the application of GDC-19 to Columbia's design. NUREG-0800, Section 9.4.1 Control Room Area Ventilation System (CRAV), provides the following GDC-19 acceptance criteria related to control room ventilation system:

4) General Design Criterion 19, as related to providing adequate protection to permit access and occupancy of the control room under accident conditions.

Acceptance is based on meeting the guidance of Regulatory Guide 1.78 relating to instrumentation to detect and alarm any hazardous chemical release in the plant vicinity and relating to the systems capability to isolate the control room from such releases and the systems capability to meet the single failure

RESPONSE TO NON-CITED VIOLATION

Attachment

Page 13 of 17

criterion, positions C.3, C.7, and C.14, respectively; and Regulatory Guide 1.95 relating to the systems capability to limit the accumulation of chlorine within the control room and the systems capability to meet the single failure criterion, positions C.4a and C.4d.

As can be seen, there were no criteria associated with operator comfort in order to meet GDC-19 requirements.

- Section 18.1 of NUREG-0892 documents an additional consideration the NRC used to assure that appropriate design standards were implemented for the control room. Section 18.1 states the following regarding the use of NUREG-0700:

18 HUMAN FACTORS ENGINEERING

18.1 Background

As part of the NRC task actions following the TMI-2 accident (Item I.D.1, NUREG-0660, May 1980, and NUREG-0737, November 1980), the staff requires all licensees and applicants for operating licenses to conduct a detailed control room design review (DCRDR) to identify and correct human engineering discrepancies (HEDs). These DCRDRs will be performed in accordance with NUREG-0700, "Guidelines for Control Room Design Reviews," issued September 1981.

- NUREG-0700 provided detailed guidelines for reviewing human engineering suitability of control rooms. In section 6.1.5.1 it provides the following temperature related guideline:

6.1.5.1 TEMPERATURE AND HUMIDITY

a. COMFORT ZONE-The climate control system should be capable of maintaining temperature and humidity within the shaded area comfort zone shown in Exhibit 6.1-21.

- In letter number Go2-85-758, dated November 1, 1985, Washington Public Power Supply System (Energy Northwest) submitted to the NRC its completed DCRDR summary report.
- In response, the NRC provided a safety evaluation of Columbia's DCRDR in a letter dated October 13, 1987, Detailed Control Room Design Review which documented certain discrepancies not addressed therein, but no discrepancies in the Columbia DCRDR were related to maintaining control room temperature.

RESPONSE TO NON-CITED VIOLATION

Attachment

Page 14 of 17

- c. With regard to NUREG/CR-4960, issued by the NRC in 1988 that assess control room habitability designs and describes the purpose and approach as follows:

This document presents the results of a survey of control room habitability systems at twelve licensed nuclear power plants conducted in 1985 through 1987. The survey, conducted by Argonne National Laboratory (ANL), is part of an NRC program initiated in August 1983 in response to concerns and recommendations of the Advisory Committee on Reactor Safeguards (ACRS). These questions concerned the suitability of control rooms in current commercial reactors to provide adequate environmental conditions during both normal and abnormal operations.

The report provides plant-specific and generalized findings regarding safety functions with respect to the consistency of the design, construction, operation and testing of control room habitability systems and corresponding Technical Specifications compared with descriptions provided in the license basis documentation (licensee NUREG-0737 Item III.D.3.4 submittals and updated Safety Analysis Reports, and NRC Safety Evaluation Reports) including assumptions in the operator toxic gas concentration and radiation dose calculations.

- Appendix L of this report evaluates WNP-2 (Columbia) and makes the following conclusion with regard to the fidelity of the design to Columbia's FSAR:

8.3 Safety Analysis

The Control Room (CR) HVAC system was found to be as described in the USAR and material provided by the utility (WPPSS), except as follows:

The exceptions that were provided make no mention of Columbia's chilled water system design.

- d. The NRC also indicated in the inspection report, as documented below, that a crosscutting aspect would be assigned due to an incomplete response to a 2013 finding:

This finding had a cross-cutting aspect in the area of problem identification and resolution, evaluation, in that the licensee did not thoroughly evaluate issues to ensure that resolutions address causes and extent of conditions commensurate with their safety significance. Specifically, the licensee did not thoroughly evaluate the extent of condition from NRC-identified NCV 05000397/2013002-04, "Failure to Obtain NRC Approval for Changes to

RESPONSE TO NON-CITED VIOLATION

Attachment

Page 15 of 17

Control Room HVAC Requirements,” for the effect of this change on other station calculations [P.2]

- The violation in NRC Integrated Inspection Report 05000397/2013002 was for changing CR habitability requirements from 75 degrees Fahrenheit (F) ± 3 degrees F to 85 degrees F effective temperature without obtaining a license amendment.
- Energy Northwest actions following the 2013 violation included the following:
 - An extensive review of the licensing basis was conducted to reestablish the operator comfort level at 85°F dry bulb based on the surveillance requirement in the original Technical Specification 4.7.2.a. This resulted in revision of the Final Safety Analysis Report (FSAR) section 9.4.1.
 - A revision to the Licensee Controlled Specification 1.7.2 was implemented to ensure that the operability of the control room HVAC system was immediately assessed upon a loss of functionality of one or more emergency chilled water subsystems.
 - A revision to the Technical Specification Bases 3.7.4 was implemented to describe the operator comfort level of 85°F dry bulb temperature.
- At no time were the above changes intended to imply that the operator comfort level was a design basis limit. The changes made are consistent with the requirements of Surveillance Requirement 3.7.4.1 which verifies that each control room HVAC subsystem has the capability to remove the assumed heat load without reference to a maximum temperature limit.
- Temperature limits for the control room are controlled in the Licensee Controlled Specification 1.7.1, which were specifically relocated from former TS 3/4.7.8 during the conversion to the Improved Technical Specifications at Amendment No. 149. These temperatures are related to equipment operability.

4. Consideration for transient conditions during initial startup of support systems was established after Columbia was licensed

Supporting details are as follows:

- a. The NRC assessed transient conditions through the Control Room Habitability Working Group as documented in a memo from HR Denton (Director NRR) to WJ Dircks (EDO) on June 29, 1984 (ML041900518).

RESPONSE TO NON-CITED VIOLATION

Attachment

Page 16 of 17

This working group responded to ACRS concerns for the sufficiency of NUREG-0660, NRC Action Plan Developed as a Result of the TMI-2 Accident. This document was issued after Columbia was licensed to operate in December 1983.

Recommendations 4 and 5 of this report propose further study on the topic of Operator comfort which would suggest that there were no existing requirements for ensuring operator comfort levels were not exceeded. It even offers a recommendation for a temporary exceedance above comfort levels. The following is an excerpt from this letter (emphasis added):

4.2.4 Recommendation 4

Limiting environmental conditions for operation in the control room should be established and should consider human performance as well as equipment operation as the basis for selection of appropriate limits.

Discussion

The current technical specification limit for temperature in the control room is based on equipment qualification temperatures. If the human operator is considered to be an Integral subsystem required for safe plant operation, then the limiting conditions for operation in the control room should be based on the more limiting performer whether it be equipment or human. Some of the environmental factors which should be included for consideration are temperature, noise, and illumination. Effective temperature (ET) takes into account dry bulb temperature, relative humidity, and air velocity. Air velocity has a minimal effect in the low ranges expected in a control room (under 100 feet/minute) and can be safely ignored as a contributor to ET-differences. An effective temperature of 85 °F has been determined to be the maximum limit for reliable human performance. The 85 °F (ET) ranges from 85 °F dry bulb temperature at 100% relative humidity to 104 °F dry bulb temperature at 20% relative humidity. The working group recommends that a maximum temperature limitation of 85 °F (ET) be established for the control room as the limiting condition for operation. If relative humidity is not measured or monitored in a control room, a dry bulb temperature of 85 °F should be used as the limiting condition. This limit should not be exceeded for longer than one hour.

4.2.5 Recommendation 5

The working group recommends that the following generic studies related to control room habitability be conducted:

..(2) Evaluation of the potential for loss of both trains of the ventilation system and its effect on habitability and equipment operability. Consideration should

RESPONSE TO NON-CITED VIOLATION

Attachment

Page 17 of 17

be given to the need for providing guidance to control room operators on appropriate actions in such an event...

The proposed study should also consider appropriate actions to be required by Technical Specifications in response to loss of one or more trains of the ventilation system and possible guidance which could be given to control room operators to decrease heat loads in the control room. By shedding heat loads, by opening doors, and by taking other temporary actions, the operators may be able to extend their occupancy time long enough so that the ventilation system can be restored before the control room becomes uninhabitable.

These four items, therefore, form the basis for Energy Northwest's denial of the NCV as it relates to operator comfort requirements.

G. Conclusion

In conclusion, the NRC's application of a standard that was not even considered at the time of Columbia licensing, nor imposed on Columbia by the NRC at any time since, does not support a conclusion that a "design basis" related violation occurred (i.e., 10 CFR 50, Appendix B, Criterion III). Energy Northwest denies such a violation exists. Further, Energy Northwest respectfully requests that the NRC reconsider the finding related to control room operator comfort levels and either withdraw the finding or else complete a backfit analysis in accordance with 10 CFR 50.109 to support the imposition of new requirements.