

ENCLOSURE 5

GEH Technical Report

WG3-U71-ERD-S-0004 Revision 0

Reactor Building Structural Design Report



STRUCTURAL DESIGN REPORT

REVISION STATUS SHEET

Document Title: Reactor Building Structural Design Report

Revision #: 0 **Type:** Engineering Report – Design

Safety Related Classification Code: N/A **MPL No.:** U71-5010

“|” Vertical Sidebar Denotes Change

Rev #	DOORS BL	Change Number	MM/DD/YYYY	Preparing Organization	Issue / Release Status	Verification Status
0	N/A	ECO-0015264	11/10/2015	GEH	Issued for Use-Design	Verified

MADE BY	APPROVALS	AUTH. DATE
Gary Ehler GEH	Tanya B. Kirby GEH	11/10/2015

Public Information Notice

This is a public version of WG3-U71-ERD-S-0004, Rev 0, from which the security-related information has been removed. Portions of the document that have been removed are indicated by white space within single brackets as shown here { }. The footer of each page where security-related information is withheld carries the notation “{{{Security-Related Information - Withheld Under 10 CFR 2.390}}}.”

IMPORTANT NOTICE REGARDING CONTENTS OF THIS REPORT
Please Read Carefully

The design, engineering, and other information contained in this document are furnished for the purpose(s) stated in the “Development Agreement between Virginia Electric and Power Company and the consortium of GE-Hitachi Nuclear Energy Americas LLC and Fluor Enterprises, Inc.” dated April 5, 2013 as amended. The use of this information by anyone other than Virginia Electric and Power Company, or for any purpose other than that for which it is furnished by GEH is not authorized; and with respect to any unauthorized use, GEH makes no representation or warranty, express or implied, and assumes no liability as to the completeness, accuracy, or usefulness of the information contained in this document, or that its use may not infringe privately owned rights.

Copyright 2015, GE-Hitachi Nuclear Energy Americas LLC, All Rights Reserved



HITACHI

WG3-U71-ERD-S-0004 SH NO. 3
REV. 0 of 538

RECORD OF REVISION

Rev #	Description
0	Initial issue



TABLE OF CONTENTS

- 1. SCOPE18
- 2. APPLICABLE DOCUMENTS18
 - 2.1 Supporting and Supplemental Documents18
 - 2.1.1 Supporting Documents.....18
 - 2.1.2 Supplemental Documents19
 - 2.2 Industry Codes and Standards.....19
 - 2.3 Regulation and Regulatory Requirements20
 - 2.4 References20
- 3. STRUCTURAL DESCRIPTION AND GEOMETRY20
 - 3.1 Structural Geometry and Dimensions20
 - 3.2 Key Structural Elements and Descriptions20
 - 3.3 Floor Layout and Elevations21
 - 3.4 Conditions of Vicinity and Support21
 - 3.5 Special Structural Features.....21
- 4. STRUCTURAL MATERIAL REQUIREMENTS22
 - 4.1 Concrete22
 - 4.2 Reinforcement.....22
 - 4.3 Structural Steel.....22
 - 4.3.1 Carbon Steel Plate and Shapes.....22
 - 4.3.2 Stainless Steel Plate23
 - 4.3.3 Steel Decking.....23
- 5. STRUCTURAL LOADS23
 - 5.1 Live Loads and Dead Loads.....23
 - 5.1.1 Dead Loads23
 - 5.1.2 Live Loads24
 - 5.2 Transient Loads.....24
 - 5.2.1 Pressure Loads24
 - 5.2.1.1 Containment Pressure Loads.....24
 - 5.2.1.2 High Energy Line Break (HELB) Loads25
 - 5.2.2 Thermal Loads25
 - 5.2.2.1 Normal Temperatures (To)25
 - 5.2.2.2 Accident Temperatures (Ta)25
 - 5.2.3 Hydrodynamic Loads.....26
 - 5.2.3.1 Safety/Relief Valve (SRV) Loads.....26
 - 5.2.3.2 Chugging (CH) Loads.....26
 - 5.2.3.3 Condensation Oscillation (CO) Loads27
 - 5.2.3.4 Pool Swell27
 - 5.2.4 RPV Reactions due to Hydrodynamic Loads27
 - 5.3 Environmental Loads28
 - 5.3.1 Wind Loads.....28
 - 5.3.2 Tornado Loads28



5.3.3	Seismic Loads	28
6.	STRUCTURAL ANALYSIS AND DESIGN	29
6.1	General Description	29
6.2	Stress Analysis	30
6.2.1	Analysis Program.....	30
6.2.2	Analysis Model	30
6.2.2.1	Outline of the Analysis Model.....	30
6.2.2.2	Modeling Principles.....	31
6.2.2.3	Modeling of the Basemat and Ground.....	32
6.2.2.4	Modeling of the RCCV.....	33
6.2.2.5	Modeling of the RCCV Liner and Sleeves	34
6.2.2.6	Modeling of the RB Pools and MS Tunnel Structures	34
6.2.2.7	Modeling of Shear Walls	34
6.2.2.8	Modeling of Floor Slabs	35
6.2.2.9	Modeling of Frame Members	35
6.2.2.10	Modeling of the Containment Internal Structures	35
6.2.2.11	Units and Material Constants.....	36
6.2.2.12	Boundary Conditions	36
6.2.3	Method of Applying Loads.....	36
6.2.3.1	Dead Load.....	36
6.2.3.2	Live Load.....	38
6.2.3.3	Pressure Load.....	38
6.2.3.4	Thermal Load.....	39
6.2.3.5	Hydrodynamic Loads.....	40
6.2.3.6	Reaction Loads due to Hydrodynamic Loads.....	40
6.2.3.7	Wind Loads.....	41
6.2.3.8	Tornado Loads	41
6.2.3.9	Seismic Loads	41
6.2.4	Analysis Results.....	46
6.3	Load Combinations	46
6.3.1	Code Requirements.....	46
6.3.2	Selection of Design Load Combinations	47
6.3.3	Result of Load Combination.....	49
6.4	Section Design Principles	49
6.4.1	Section Design of Reinforced Concrete Structures	49
6.4.1.1	Section Design for Flexure and Membrane Forces.....	49
6.4.1.2	Section Design for Membrane Compressive Forces.....	51
6.4.1.3	Section Design for Transverse Shear.....	52
6.4.2	Section Design of Steel Structures.....	53
6.4.2.1	Section Design for Axial Compression and Bending	53
6.4.2.2	Section Design for Axial Tension and Bending	54
6.4.2.3	Section Design for Transverse Shear.....	54
6.4.2.4	Allowable Stresses.....	55
7.	SUMMARY OF RESULTS	56



7.1	Required Section	56
7.2	Provided Section	57
7.3	Tabulation of Allowable Stresses versus Calculated Stresses	57
7.3.1	Reinforced Concrete Structure.....	57
7.3.1.1	Calculations for Flexure and Membrane Forces.....	57
7.3.1.2	Calculations for Membrane Compressive Forces	58
7.3.1.3	Calculations for Transverse Shear	59
7.3.2	Steel Structure.....	60
7.4	Missile Impact Evaluations	60
8.	CONCLUSIONS.....	60
Appendix A	COMPARISON WITH DCD DATA	494
Appendix B	IN-PLANE SHEAR CHECK FOR RB ACCORDING TO ACI349-01	531
Appendix C	COMPRESSION LIMIT CHECK FOR RB ACCORDING TO ACI349-01 ..	535



LIST OF TABLES

Table 3.1-1 Key Dimensions of RB and FB62

Table 3.1-2 Key Dimensions of RCCV63

Table 5.1.1-1 Weights of Miscellaneous Steels and Finishing64

Table 5.1.1-2 Miscellaneous Structures, Piping, and Commodities Attached to the RCCV.....65

Table 5.1.1-3 Miscellaneous Structures, Piping, and Commodities on the Slabs66

Table 5.1.1-4 Miscellaneous Structures, Piping, and Commodities on the RCCV Walls67

Table 5.1.1-5 Dead Loads of Equipment RB.....68

Table 5.1.1-6 Dead Loads of Equipment FB69

Table 5.1.1-7 Dead Loads of Hydrostatic Loads70

Table 5.1.2-1 Floor Live Loads71

Table 5.1.2-2 Design Lateral Soil Pressure at-Rest72

Table 5.2.1-1 Design Pressure Loads for Containment and IC/PCCS Pools.....73

Table 5.2.1-2 Design Times for LOCAs.....73

Table 5.2.2-1 Steady State Temperature Conditions74

Table 5.2.2-2 Design Basis Accident Temperatures in Spent Fuel Pool74

Table 5.2.4-1 RPV Reactions.....75

Table 5.3.1-1 Design Wind Pressure Loads by Floor Level.....76

Table 5.3.2-1 Design Pressure of Tornado Wind Load76

Table 5.3.3-1 Design Seismic Loads for Horizontal SSE (RB and FB Walls).....77

Table 5.3.3-2 Design Seismic Loads for Horizontal SSE (RCCV)78

Table 5.3.3-3 Design Seismic Loads for Horizontal SSE (RPV Pedestal and Vent Wall).....79

Table 5.3.3-4 Design Seismic Loads for Horizontal SSE (RSW)80

Table 5.3.3-5 Design Seismic Loads for Horizontal SSE (RPV)81

Table 5.3.3-6 Maximum Vertical Accelerations (RB and FB).....82

Table 5.3.3-7 Maximum Vertical Accelerations (RCCV)82

Table 5.3.3-8 Maximum Vertical Accelerations (RPV Pedestal and Vent Wall)83

Table 5.3.3-9 Maximum Vertical Accelerations (RSW)83

Table 5.3.3-10 Enveloping Maximum Vertical Acceleration: RBFB Flexible Slab Oscillators.84

Table 5.3.3-11 Soil Pressure Due to an Earthquake86

Table 5.3.3-12 Sloshing Loads for GDCS Pool.....87

Table 5.3.3-13 Sloshing Loads for RPV Cavity / Dryer Separator / Fuel Buffer Pool87

Table 5.3.3-14 Sloshing Loads for IC / PCCS Pool88

Table 5.3.3-15 Sloshing Loads for Extension Pool A88

Table 5.3.3-16 Sloshing Loads for Extension Pool B.....89

Table 5.3.3-17 Sloshing Loads for Spent Fuel Pool89

Table 5.3.3-18 RPV Reactions Due to SSE.....90

Table 5.3.3-19 Enveloping Maximum Horizontal Acceleration: RBFB Wall Out-of-plane
Oscillators90

Table 6.2.2-1 List of GA Drawings Used for Modeling.....91

Table 6.2.2-2 Structural Members Considered in Analyses and Their Design92

Table 6.2.2-3 Type of Elements Used to Model Structural Members93

Table 6.2.2-4 Local Coordinate Systems.....94



Table 6.2.2-5 Soil Spring Constants for the RB Analysis Model95

Table 6.2.2-6 Levels of Floor Slabs Connected to the RCCV Wall95

Table 6.2.2-7 Dimensions of Modeled Round Openings on RCCV96

Table 6.2.2-8 Material and Thickness of the RCCV Liner97

Table 6.2.2-9 Area of Rod Elements Used in Sleeve Models97

Table 6.2.2-10 Dimensions of Modeled Rectangular Openings on RB Walls97

Table 6.2.2-11 Material Constants Used in Stress Analysis98

Table 6.2.3.2-1 Floor Live Loads99

Table 6.2.3.3-1 Load Combinations for Design Pressure Loads100

Table 6.2.3.4-1 Atmosphere Temperatures: Summer101

Table 6.2.3.4-2 Atmosphere Temperatures: Winter102

Table 6.2.3.4-3 Application of Thermal Loads: List of Indexes103

Table 6.2.3.4-4 Thermal Loads for Shell Elements Normal Operation: Summer105

Table 6.2.3.4-5 Thermal Loads for Shell Elements LOCA: 5 sec.: Summer107

Table 6.2.3.4-6 Thermal Loads for Shell Elements LOCA: 6 min.: Summer109

Table 6.2.3.4-7 Thermal Loads for Shell Elements LOCA: 10 hr.: Summer111

Table 6.2.3.4-8 Thermal Loads for Shell Elements LOCA: 72 hr.: Summer113

Table 6.2.3.4-9 Thermal Loads for Shell Elements Normal Operation: winter115

Table 6.2.3.4-10 Thermal Loads for Shell Elements LOCA: 5 sec.: Winter117

Table 6.2.3.4-11 Thermal Loads for Shell Elements LOCA: 6 min.: Winter119

Table 6.2.3.4-12 Thermal Loads for Shell Elements LOCA: 10 hr.: Winter121

Table 6.2.3.4-13 Thermal Loads for Shell Elements LOCA: 72 hr.: Winter123

Table 6.2.3.4-14 Thermal Loads for Beam Elements125

Table 6.2.3.4-15 Thermal Loads for Rod Elements of RCCV Top Head Opening at All Seasons 125

Table 6.2.3.4-16 Design Thermal Load Labels126

Table 6.2.3.4-17 Thermal Loads for Shell Elements around Spent Fuel Pool 72 hr. after DBA:
Summer127

Table 6.2.3.4-18 Thermal Loads for Shell Elements around Spent Fuel Pool 72 hr. after DBA:
Winter127

Table 6.2.3.4-19 Thermal Loads for Shell Elements LOCA: 72 hr.: Winter (Case 1)128

Table 6.2.3.4-20 Thermal Loads for Shell Elements LOCA: 72 hr.: Winter (Case 2)130

Table 6.2.3.4-21 Thermal Loads for Shell Elements LOCA: 72 hr.: Winter (Case 3)132

Table 6.2.3.4-22 Thermal Loads for Shell Elements LOCA: 72 hr.: Winter (Case 4)134

Table 6.2.3.7-1 Design Wind Loads (North Wind)136

Table 6.2.3.7-2 Design Wind Loads (South Wind)136

Table 6.2.3.7-3 Design Wind Loads (East Wind)137

Table 6.2.3.7-4 Design Wind Loads (West Wind)137

Table 6.2.3.8-1 Tornado Wind Loads (North Wind)138

Table 6.2.3.8-2 Tornado Wind Loads (South Wind)138

Table 6.2.3.8-3 Tornado Wind Loads (East Wind)139

Table 6.2.3.8-4 Tornado Wind Loads (West Wind)139

Table 6.2.3.8-5 Tornado Loads (Differential Pressure)140

Table 6.2.3.9-1 Analysis Cases for Seismic Loads141

Table 6.2.3.9-2 Seismic Wall Shear Area – X(N-S)-dir.142



Table 6.2.3.9-3 Seismic Wall Shear Area – Y(E-W)-dir.143

Table 6.2.3.9-4 Applied Shear Forces at Seismic Wall – X(N-S)-dir.144

Table 6.2.3.9-5 Applied Shear Forces at Seismic Wall – Y(E-W)-dir.145

Table 6.2.3.9-6 Applied Overturning Moment – RBFB X(N-S)-dir.146

Table 6.2.3.9-7 Applied Overturning Moment – RBFB Y(E-W)-dir.147

Table 6.2.3.9-8 Applied Overturning Moment – RCCV X(N-S)-dir.148

Table 6.2.3.9-9 Applied Overturning Moment – RCCV Y(E-W)-dir.149

Table 6.2.3.9-10 Applied Overturning Moment – RPV Pedestal X(N-S)-dir.150

Table 6.2.3.9-11 Applied Overturning Moment – RPV Pedestal Y(E-W)-dir.151

Table 6.2.3.9-12 Design Vertical Acceleration for Slabs152

Table 6.2.3.9-13 Applied Shear Forces for Seismic Wall due to Torsional Moment.....153

Table 6.2.3.9-14 Load Combinations for Design Seismic Loads157

Table 6.2.3.9-15 Design Acceleration for Seismic Walls.....158

Table 6.2.4-1 Results of NASTRAN Analysis, Dead Load159

Table 6.2.4-2 Results of NASTRAN Analysis, Drywell Unit Pressure (1 MPa)160

Table 6.2.4-3 Results of NASTRAN Analysis, Wetwell Unit Pressure (1 MPa).....161

Table 6.2.4-4 Results of NASTRAN Analysis, Thermal Load (Normal Operation: Winter) ...162

Table 6.2.4-5 Results of NASTRAN Analysis, Thermal Load (LOCA After 6 minutes: Winter)163

Table 6.2.4-6 Results of NASTRAN Analysis, Thermal Load (LOCA After 72 hours: Winter) –
Load Case: TLW8 –164

Table 6.2.4-7 Results of NASTRAN Analysis, Thermal Load (LOCA After 72 hours: Winter) –
Load Case: TWC1 –165

Table 6.2.4-8 Results of NASTRAN Analysis, Thermal Load (LOCA After 72 hours: Winter) –
Load Case: TWC2 –166

Table 6.2.4-9 Results of NASTRAN Analysis, Thermal Load (LOCA After 72 hours: Winter) –
Load Case: TWC3 –167

Table 6.2.4-10 Results of NASTRAN Analysis, Thermal Load (LOCA After 72 hours: Winter)
– Load Case: TWC4 –168

Table 6.2.4-11 Results of NASTRAN Analysis, Site-Specific Seismic Load (Horizontal: North
to South Direction).....169

Table 6.2.4-12 Results of NASTRAN Analysis, Site-Specific Seismic Load (Horizontal: East to
West Direction).....170

Table 6.2.4-13 Results of NASTRAN Analysis, Site-Specific Seismic Load (Vertical: Upward
Direction)171

Table 6.3.1-1 Load Combinations and Acceptance Criteria for Safety-Related Reinforced
Concrete Structures172

Table 6.3.1-2 Load Combinations, Load Factors and Acceptance Criteria for Reinforced
Concrete Containment173

Table 6.3.1-3 Load Combinations and Acceptance Criteria for Safety-Related Steel Structures174

Table 6.3.2-1 Detail Load Combinations for RB Design175

Table 6.3.2-2 Detail Load Combinations for Steel Structures179

Table 6.3.3-1 Combined Forces and Moments: 1.05D + 1.3L +1.3To + 1.3W: Winter: Load ID
= 4021 (Selected Load Combination RB-4)182



Table 6.3.3-2 Combined Forces and Moments: 6-min. after LOCA (1.5Pa): Winter: Load ID = 6241 (Selected Load Combination RB-8a).....184

Table 6.3.3-3 Combined Forces and Moments: 72-hr. after LOCA (1.5Pa): Winter: Load ID = 6441 (Selected Load Combination RB-8b).....188

Table 6.3.3-4 Combined Forces and Moments: LOCA + SSE: 6-min. after: Winter: Load ID = 7241 (Site-Specific Seismic Load Combination RB-9a).....192

Table 6.3.3-5 Combined Forces and Moments: LOCA + SSE: 72-hr. after: Winter: Load ID = 7441 (Site-Specific Seismic Load Combination RB-9b).....197

Table 6.4.1-1 Material Constants for Stress Calculations.....202

Table 6.4.1-2 Allowable Stress of Concrete for Membrane Plus Bending.....202

Table 6.4.1-3 Allowable Stress of Reinforcement for Membrane Plus Bending203

Table 6.4.1-4 Allowable Stress of Concrete for Membrane Compressive Forces.....203

Table 7.3.1.1-1 Sectional Thicknesses and Rebar Ratios of RB Used in the Evaluation.....204

Table 7.3.1.1-3 Rebar and Concrete Stresses of RB: 6-min. after LOCA (1.5Pa): Winter: Load ID = 6241(Selected Load Combination RB-8a)209

Table 7.3.1.1-4 Rebar and Concrete Stresses of RB: 72-hr. after LOCA (1.5Pa): Winter: Load ID = 6441(Selected Load Combination RB-8b)211

Table 7.3.1.1-5 Rebar and Concrete Stresses of RB: LOCA + SSE: 6-min. after: Winter: Load ID = 7241(Site-Specific Seismic Load Combination RB-9a)213

Table 7.3.1.1-6 Rebar and Concrete Stresses of RB: LOCA + SSE: 72-hr. after: Winter: Load ID = 7441(Site-Specific Seismic Load Combination RB-9b)215

Table 7.3.1.1-7 Maximum Stress Ratios for Flexure and Membrane Forces217

Table 7.3.1.2-1 Membrane Compressive Forces of RB.....219

Table 7.3.1.3-1 Transverse Shear of RB.....220

Table 7.3.1.3-2 Transverse Shear of RB for DCD Load Combinations221

Table 7.3.2-1 Maximum Stress Ratio of Truss Girder and Column.....222



LIST OF FIGURES

Figure 3.1-1 RB and FB Concrete Outline Plan at EL -11,500224
Figure 3.1-2 RB and FB Concrete Outline Plan at EL 4,650225
Figure 3.1-3 RB and FB Concrete Outline Plan at EL 17,500226
Figure 3.1-4 RB and FB Concrete Outline Plan at EL 27,000227
Figure 3.1-5 RB Concrete Outline Plan at EL 34,000228
Figure 3.1-6 RB and FB Concrete Outline N-S Section.....229
Figure 3.1-7 RB and FB Concrete Outline E-W Section.....230
Figure 3.2-1 Configuration of RCCV231
Figure 3.2-2 Locations of Various Pools in RB and FB232
Figure 5.1.1-1 Regions for Equipment Loads at EL -11,500.....233
Figure 5.1.1-2 Regions for Equipment Loads at EL -6,400.....234
Figure 5.1.1-3 Regions for Equipment Loads at EL -1,000.....235
Figure 5.1.1-4 Regions for Equipment Loads at EL 4,650236
Figure 5.1.1-5 Regions for Equipment Loads at EL 9,060.....237
Figure 5.1.1-6 Regions for Equipment Loads at EL 13,570238
Figure 5.1.1-7 Regions for Equipment Loads at EL 22,500239
Figure 5.1.1-8 Regions for Equipment Loads at EL 27,000240
Figure 5.1.1-9 Regions for Equipment Loads at/above EL 34,000241
Figure 5.1.2-1 Snow Load242
Figure 5.2.1-1 Envelopes of Transient Pressure Curves at DBA243
Figure 5.2.1-2 Regions Where Pressure Loads are Applied in IC/PCCS Pools244
Figure 5.2.2-1 Envelopes of Transient Temperature Curves - Inside RCCV at DBA.....245
Figure 5.2.2-2 Envelopes of Transient Temperature Curves – Other Pools at DBA.....246
Figure 5.2.2-3 Temperature Distributions in Upper Pools247
Figure 5.2.3-1 Safety Relief Valve (SRV) Pressure Loads248
Figure 5.2.3-2 Typical Event – Time Relationship for a DBA.....249
Figure 5.2.3-3 Chugging (CH) Pressure Loads250
Figure 5.2.3-4 Condensation Oscillation (CO) Pressure Loads.....251
Figure 5.2.3-5 Pool Swell (PS) Pressure Loads.....252
Figure 5.2.3-6 Pool Swell (PS) Pressure Concurrent with Froth Impact Loads253
Figure 5.3.3-1 Dynamic Analysis Model.....254
Figure 5.3.3-2 Position of Each Pool.....255
Figure 6.2.2-1 FE Model of RB/FB (Whole View)256
Figure 6.2.2-2 FE Model of RB/FB (Cut View).....257
Figure 6.2.2-3 FE Model of RCCV Liner.....258
Figure 6.2.2-4 FE Model of RCCV Internal Structures.....259
Figure 6.2.2-5 FE Model of the Basemat.....260
Figure 6.2.2-6 FE Model of the Basemat inside the Containment.....261
Figure 6.2.2-7 FE Model of the RCCV Cylinder Wall and the Wall below RCCV.....262
Figure 6.2.2-8 FE Model of the RPV Pedestal Wall.....263
Figure 6.2.2-9 FE Model of the Top Slab.....264
Figure 6.2.2-10 FE Model of the Suppression Pool Floor Slab.....265



Figure 6.2.2-11 FE Model of the RCCV Cylinder Wall Liner266

Figure 6.2.2-12 FE Model of the RPV Pedestal Wall Liner267

Figure 6.2.2-13 FE Model of the Basemat Liner (EL -10,400)268

Figure 6.2.2-14 FE Model of the Suppression Pool Floor Slab Liner (EL 4,650)269

Figure 6.2.2-15 FE Model of the Top Slab Liner (EL 24,600).....270

Figure 6.2.2-16 Rigid Bar Elements between Concrete and Liner271

Figure 6.2.2-17 FE Model of Sleeve at the RCCV Top Head Opening272

Figure 6.2.2-18 Modeled RB Pool Walls Except External Walls at EL 27,000273

Figure 6.2.2-19 FE Model of the Pool Girders274

Figure 6.2.2-20 Layout of Inner Walls Included in the Analysis Model at EL -11,500275

Figure 6.2.2-21 Layout of Inner Walls Included in the Analysis Model at EL -6,400276

Figure 6.2.2-22 Layout of Inner Walls Included in the Analysis Model at EL -1,000277

Figure 6.2.2-23 FE Model of the External Wall (RA/FA Column Line)278

Figure 6.2.2-24 FE Model of the External Wall (RG/FF Column Line)279

Figure 6.2.2-25 FE Model of the External Wall (R1 Column Line).....280

Figure 6.2.2-26 FE Model of the External Wall (R7/F1 Column Line)281

Figure 6.2.2-27 FE Model of the External Wall (F3 Column Line)282

Figure 6.2.2-28 FE Model of the Slab at EL 4,650.....283

Figure 6.2.2-29 FE Model of the Slab at EL 17,500.....284

Figure 6.2.2-30 FE Model of the Slab at EL 27,000.....285

Figure 6.2.2-31 FE Model of the FB Frame (FB Column Line).....286

Figure 6.2.2-32 FE Model of the FB Frame (FC Column Line).....287

Figure 6.2.2-33 FE Model of the FB Frame (FD Column Line)288

Figure 6.2.2-34 FE Model of the FB Frame (FE Column Line).....289

Figure 6.2.2-35 FE Model of the FB Frame (F2 Column Line)290

Figure 6.2.2-36 FE Model of the Roof Truss (R4 Column Line).....291

Figure 6.2.3.1-1 Equipment Loads at EL -11,500292

Figure 6.2.3.1-2 Equipment Loads at EL -6,400293

Figure 6.2.3.1-3 Equipment Loads at EL -1,000294

Figure 6.2.3.1-4 Equipment Loads at EL 4,650.....295

Figure 6.2.3.1-5 Equipment Loads at EL 9,060.....296

Figure 6.2.3.1-6 Equipment Loads at EL 13,570.....297

Figure 6.2.3.1-7 Equipment Loads at EL 22,500.....298

Figure 6.2.3.1-8 Equipment Loads at EL 27,000.....299

Figure 6.2.3.1-9 Equipment Loads at EL 34,000.....300

Figure 6.2.3.1-10 Equipment Loads above EL 34,000301

Figure 6.2.3.1-11 Hydrostatic Loads on the Basemat.....302

Figure 6.2.3.1-12 Hydrostatic Loads on the Slab at EL -1,000303

Figure 6.2.3.1-13 Hydrostatic Loads on the Suppression Pool Floor Liner304

Figure 6.2.3.1-14 Hydrostatic Loads on the Slab at EL 27,000.....305

Figure 6.2.3.1-15 Hydrostatic Loads on the RCCV Wall Liner306

Figure 6.2.3.1-16 Hydrostatic Loads during LOCA Flooding on the RPV Pedestal Liner307

Figure 6.2.3.1-17 Hydrostatic Loads during LOCA Flooding on the RCCV Liner308

Figure 6.2.3.1-18 Hydrostatic Loads on the RA FA External Wall309



Figure 6.2.3.1-19 Hydrostatic Loads on the RG/FF External Wall.....310

Figure 6.2.3.1-20 Hydrostatic Loads on the R1 External Wall311

Figure 6.2.3.1-21 Hydrostatic Loads on the R7/F1 External Wall312

Figure 6.2.3.1-22 Hydrostatic Loads on the F3 External Wall.....313

Figure 6.2.3.1-23 Hydrostatic Loads on the Inner Wall at EL -11,500 (1)314

Figure 6.2.3.1-24 Hydrostatic Loads on the Inner Wall at EL -11,500 (2)315

Figure 6.2.3.1-25 Hydrostatic Loads on the Inner Wall at EL -11,500 (3)316

Figure 6.2.3.1-26 Hydrostatic Loads on the Inner Wall at EL -11,500 (4)317

Figure 6.2.3.1-27 Hydrostatic Loads on the Pool Girder.....318

Figure 6.2.3.1-28 Hydrostatic Loads on the Inner Wall at EL 27,000 (RB)319

Figure 6.2.3.1-29 Hydrostatic Loads on the Inner Wall at EL 27,000 (RF)320

Figure 6.2.3.1-30 Hydrostatic Loads on the Inner Wall at EL 27,000 (R2)321

Figure 6.2.3.1-31 Hydrostatic Loads on the Inner Wall at EL 27,000 (R6)321

Figure 6.2.3.1-32 Hydrostatic Loads on the Inner Wall at EL 27,000 (1).....322

Figure 6.2.3.1-33 Hydrostatic Loads on the Inner Wall at EL 27,000 (2).....323

Figure 6.2.3.1-34 Hydrostatic Loads during LOCA Flooding on the Basemat Liner324

Figure 6.2.3.1-35 Hydrostatic Loads during LOCA Flooding on the Suppression Pool Liner ..325

Figure 6.2.3.2-1 Floor Live Load Enveloped Snow Drift Load for Lower Roofs.....326

Figure 6.2.3.2-2 Floor Live Load (FB EL 22,500)327

Figure 6.2.3.2-3 Lateral Soil Pressure Load at Rest (Basemat).....328

Figure 6.2.3.2-4 Lateral Soil Pressure Load at Rest (RA/FA External Wall)329

Figure 6.2.3.2-5 Lateral Soil Pressure Load at Rest (RG/FF External Wall)330

Figure 6.2.3.2-6 Lateral Soil Pressure Load at Rest (R1 External Wall).....331

Figure 6.2.3.2-7 Lateral Soil Pressure Load at Rest (F3 External Wall).....332

Figure 6.2.3.3-1 Containment Pressure Loads - Drywell Unit Pressure.....333

Figure 6.2.3.3-2 Containment Pressure Loads - Wetwell Unit Pressure334

Figure 6.2.3.3-3 Containment Pressure Load (Drywell: RCCV Liner).....335

Figure 6.2.3.3-4 Containment Pressure Load (Drywell: RPV Pedestal Liner).....336

Figure 6.2.3.3-5 Containment Pressure Load (Drywell: Basemat Liner).....337

Figure 6.2.3.3-6 Containment Pressure Load (Drywell: Topslab Liner).....338

Figure 6.2.3.3-7 Containment Pressure Load (Wetwell: RCCV Liner)339

Figure 6.2.3.3-8 Containment Pressure Load (Wetwell: Suppression Pool Slab Liner)340

Figure 6.2.3.3-9 Containment Pressure Load (IC/PCCS Pool: Slab at EL 27,000)341

Figure 6.2.3.3-10 Containment Pressure Load (IC/PCCS Pool: Slab at EL 34,000)342

Figure 6.2.3.3-11 Containment Pressure Load (IC/PCCS Pool: External Wall RA)343

Figure 6.2.3.3-12 Containment Pressure Load (IC/PCCS Pool: External Wall RG)344

Figure 6.2.3.3-13 Containment Pressure Load (IC/PCCS Pool: External Wall R1)345

Figure 6.2.3.3-14 Containment Pressure Load (IC/PCCS Pool: Wall RB)346

Figure 6.2.3.3-15 Containment Pressure Load (IC/PCCS Pool: Wall RF).....347

Figure 6.2.3.3-16 Containment Pressure Load (IC/PCCS Pool: Wall R2).....348

Figure 6.2.3.3-17 Containment Pressure Load (IC/PCCS Pool: Wall R6).....349

Figure 6.2.3.3-18 Containment Pressure Load (IC/PCCS Pool: Pool Girder).....350

Figure 6.2.3.3-19 Containment Pressure Load (IC/PCCS Pool: Wall-1)351

Figure 6.2.3.3-20 Containment Pressure Load (IC/PCCS Pool: Wall-2)352



Figure 6.2.3.3-21 HELB Pressure Load (MS Tunnel: Slab at EL 17,500).....353

Figure 6.2.3.3-22 HELB Pressure Load (MS Tunnel: Slab at EL 27,000).....354

Figure 6.2.3.3-23 HELB Pressure Load (MS Tunnel: RCCV Wall).....355

Figure 6.2.3.3-24 HELB Pressure Load (MS Tunnel: Walls)356

Figure 6.2.3.3-25 HELB Pressure Load (for RB General Rooms: R1 Wall)357

Figure 6.2.3.3-26 HELB Pressure Load (for RB General Rooms: R7 Wall)358

Figure 6.2.3.3-27 HELB Pressure Load (for RB General Rooms: RB Wall).....359

Figure 6.2.3.3-28 HELB Pressure Load (for RB General Rooms: RF Wall)360

Figure 6.2.3.3-29 HELB Pressure Load (for RB General Rooms: Roof).....361

Figure 6.2.3.3-30 HELB Pressure Load (for FB General Rooms: F3 Wall)362

Figure 6.2.3.3-31 HELB Pressure Load (for FB General Rooms: FA Wall)363

Figure 6.2.3.3-32 HELB Pressure Load (for FB General Rooms: FF Wall).....364

Figure 6.2.3.3-33 HELB Pressure Load (for FB General Rooms: Slab at EL 22500)365

Figure 6.2.3.4-1 Application of Thermal Load on the RCCV Wall (Normal Operation)366

Figure 6.2.3.4-2 Application of Thermal Load on the RCCV Wall (LOCA Condition 1).....367

Figure 6.2.3.4-3 Application of Thermal Load on the RCCV Wall (LOCA Condition 2).....368

Figure 6.2.3.4-4 Application of Thermal Load on the RCCV Wall (LOCA Flooding Condition 3)369

Figure 6.2.3.4-5 Application of Thermal Load on the External Wall (RA/FA)370

Figure 6.2.3.4-6 Application of Thermal Load on the External Wall (RG/FF).....371

Figure 6.2.3.4-7 Application of Thermal Load on the External Wall (RB).....372

Figure 6.2.3.4-8 Application of Thermal Load on the External Wall (RF).....373

Figure 6.2.3.4-9 Application of Thermal Load on the External Wall (R1)374

Figure 6.2.3.4-10 Application of Thermal Load on the External Wall (R7/F1).....375

Figure 6.2.3.4-11 Application of Thermal Load on the External Wall (F3).....376

Figure 6.2.3.4-12 Application of Thermal Load on the Basemat377

Figure 6.2.3.4-13 Application of Thermal Load on the Basemat (during LOCA Flooding).....378

Figure 6.2.3.4-14 Application of Thermal Load on the Slab (EL 4,650)379

Figure 6.2.3.4-15 Application of Thermal Load on the Slab (EL 17,500)380

Figure 6.2.3.4-16 Application of Thermal Load on the Slab (EL 27,000)381

Figure 6.2.3.4-17 Application of Thermal Load on the Slab (EL 34,000)382

Figure 6.2.3.4-18 Application of Thermal Load on the Spent Fuel Pool Wall-1383

Figure 6.2.3.4-19 Application of Thermal Load on the Spent Fuel Pool Wall-2384

Figure 6.2.3.4-20 Application of Thermal Load on the Spent Fuel Pool Wall-3385

Figure 6.2.3.4-21 Application of Thermal Load on the MS Tunnel Wall386

Figure 6.2.3.4-22 Application of Thermal Load on the Pool Girder387

Figure 6.2.3.4-23 Application of Thermal Load on the IC/PCCS Pool Wall-1 (1).....388

Figure 6.2.3.4-24 Application of Thermal Load on the IC/PCCS Pool Wall-1(2).....389

Figure 6.2.3.4-25 Application of Thermal Load on the IC/PCCS Pool Wall-5 (R2)390

Figure 6.2.3.4-26 Application of Thermal Load on the IC/PCCS Pool Wall-6 (R6)391

Figure 6.2.3.4-27 Application of Thermal Load on the RCCV Liner (Normal Operation)392

Figure 6.2.3.4-28 Application of Thermal Load on the RCCV Liner (Condition 1).....393

Figure 6.2.3.4-29 Application of Thermal Load on the RCCV Liner (Condition 2).....394

Figure 6.2.3.4-30 Application of Thermal Load on the RCCV Liner (Condition 3).....395



Figure 6.2.3.4-31 Application of Thermal Load on the Reinforced Concrete Girder and Column (EL -11.500).....396

Figure 6.2.3.4-32 Application of Thermal Load on the Reinforced Concrete Girder and Column (EL -6.400).....397

Figure 6.2.3.4-33 Application of Thermal Load on the Reinforced Concrete Girder and Column (EL -1.000).....398

Figure 6.2.3.4-34 Application of Thermal Load on the Reinforced Concrete Girder and Column (EL 4,650).....399

Figure 6.2.3.4-35 Application of Thermal Load on the Reinforced Concrete Girder and Column (EL 9,060).....400

Figure 6.2.3.4-36 Application of Thermal Load on the Reinforced Concrete Girder and Column (EL 13,570).....401

Figure 6.2.3.5-1 Application of Hydrodynamic Load on the RCCV Liner (SRV Positive).....402

Figure 6.2.3.5-2 Application of Hydrodynamic Load on the Suppression Pool Slab Liner (SRV Positive)403

Figure 6.2.3.5-3 Application of Hydrodynamic Load on the RCCV Liner (SRV; Negative)....404

Figure 6.2.3.5-4 Application of Hydrodynamic Load on the Suppression Pool Slab Liner (SRV Negative).....405

Figure 6.2.3.5-5 Application of Hydrodynamic Load on the RCCV Liner (CH Positive).....406

Figure 6.2.3.5-6 Application of Hydrodynamic Load on the Suppression Pool Slab Liner (CH Positive)407

Figure 6.2.3.5-7 Application of Hydrodynamic Load on the RCCV Liner (CH; Negative).....408

Figure 6.2.3.5-8 Application of Hydrodynamic Load on the Suppression Pool Slab Liner (CH Negative).....409

Figure 6.2.3.5-9 Application of Hydrodynamic Load on the RCCV Liner (CO Positive/Negative).....410

Figure 6.2.3.5-10 Application of Hydrodynamic Load on the Suppression Pool Slab Liner (CO Positive/Negative).....411

Figure 6.2.3.5-11 Application of Hydrodynamic Load on the RCCV Liner (PS).....412

Figure 6.2.3.5-12 Application of Hydrodynamic Load on the RPV Pedestal Liner (PS).....413

Figure 6.2.3.5-13 Application of Hydrodynamic Load on the Basemat Liner (PS).....414

Figure 6.2.3.5-14 Application of Hydrodynamic Load on the Suppression Pool Slab Liner (PS)415

Figure 6.2.3.5-15 Application of Hydrodynamic Load on the Top Slab Liner (PS).....416

Figure 6.2.3.5-16 Application of Hydrodynamic Load on the RCCV Liner (PS: Pressure Concurrent with Froth Impact Loads).....417

Figure 6.2.3.5-17 Application of Hydrodynamic Load on the RPV Pedestal Liner (PS:Pressure Concurrent with Froth Impact Loads).....418

Figure 6.2.3.5-18 Application of Hydrodynamic Load on the Basemat Liner (PS:Pressure Concurrent with Froth Impact Loads).....419

Figure 6.2.3.5-19 Application of Hydrodynamic Load on the Suppression Pool Slab Liner (PS:Pressure Concurrent with Froth Impact Loads)420

Figure 6.2.3.5-20 Application of Hydrodynamic Load on the Top Slab Liner (PS:Pressure Concurrent with Froth Impact Loads).....421

Figure 6.2.3.9-1 Seismic Load Directions in the Stress Analysis.....422



Figure 6.2.3.9-2 Calculation of Applied Shear Forces and Moments423

Figure 6.2.3.9-3 Inner Walls Where Shear Force Are Applied - EL -11,500~EL-6,400424

Figure 6.2.3.9-4 Inner Walls Where Shear Force Are Applied - EL-6,400~EL-1,000425

Figure 6.2.3.9-5 Inner Walls Where Shear Force Are Applied - EL-1,000~EL4,650.....426

Figure 6.2.3.9-6 Distribution of Seismic Shear Forces.....427

Figure 6.2.3.9-7 Method of Applying Overturning Moments428

Figure 6.2.3.9-8 Application of Overturning Moments to the RCCV and Wall below RCCV..429

Figure 6.2.3.9-9 Application of Overturning Moments to the RPV Pedestal.....430

Figure 6.2.3.9-10 Application of Overturning Moments to the External Wall on R1 Column Line431

Figure 6.2.3.9-11 Application of Overturning Moments to the External Wall on R7 Column Line432

Figure 6.2.3.9-12 Application of Overturning Moments to the External Wall on F3 Column Line433

Figure 6.2.3.9-13 Application of Overturning Moments to the External Wall on RA Column
Line434

Figure 6.2.3.9-14 Application of Overturning Moments to the External Wall on RG Column
Line435

Figure 6.2.3.9-15 Application of Overturning Moments to the External Wall on RB Column
Line436

Figure 6.2.3.9-16 Application of Overturning Moments to the External Wall on RF Column
Line437

Figure 6.2.3.9-17 Application of Overturning Moments to the Pool Girders.....438

Figure 6.2.3.9-18 Method of Applying Overturning Moments to the Top of RCCV.....439

Figure 6.2.3.9-19 Calculation Method of Input Torsional Moment440

Figure 6.2.3.9-20 Calculation Method of Shear Forces due to Torsional Moment.....441

Figure 6.2.3.9-21 Soil Pressure Due to N-S Direction Earthquake on the Basemat.....442

Figure 6.2.3.9-22 Soil Pressure Due to N-S Direction Earthquake on the External Wall (R1
Column Line).....443

Figure 6.2.3.9-23 Soil Pressure Due to N-S Direction Earthquake on the External Wall (F3
Column Line).....444

Figure 6.2.3.9-24 Soil Pressure Due to E-W Direction Earthquake on the Basemat445

Figure 6.2.3.9-25 Soil Pressure Due to E-W Direction Earthquake on the External Wall (RA/FA
Column Line).....446

Figure 6.2.3.9-26 Soil Pressure Due to E-W Direction Earthquake on the External Wall (RG/FF
Column Line).....447

Figure 6.2.4-1 Section Deformation for Dead Load448

Figure 6.2.4-2 Section Deformation for Drywell Unit Pressure449

Figure 6.2.4-3 Section Deformation for Wetwell Unit Pressure (1 MPa)450

Figure 6.2.4-4 Section Deformation for Thermal Load (Normal Operation: Winter).....451

Figure 6.2.4-5 Section Deformation for Thermal Load (LOCA After 6 min.: Winter)452

Figure 6.2.4-6 Section Deformation for Thermal Load (LOCA After 72 hr.: Winter)453

Figure 6.2.4-7 Section Deformation for Thermal Load (Normal Operation: Summer)454

Figure 6.2.4-8 Section Deformation for Thermal Load (LOCA After 6 min.: Summer).....455

Figure 6.2.4-9 Section Deformation for Thermal Load (LOCA After 72 hr.: Summer).....456

Figure 6.2.4-10 Section Deformation for Seismic Load (Horizontal: North to South)457

Figure 6.2.4-11 Section Deformation for Seismic Load (Horizontal: East to West).....458



Figure 6.2.4-12 Section Deformation for Seismic Load (Vertical: Upward)459

Figure 6.2.4-13 Section Deformation for Soil Pressure Due to an Earthquake (N-S).....460

Figure 6.2.4-14 Section Deformation for Soil Pressure Due to an Earthquake (E-W).....461

Figure 6.2.4-15 Section Deformation for Wind Load (North Wind).....462

Figure 6.2.4-16 Section Deformation for Wind Load (South Wind).....463

Figure 6.2.4-17 Section Deformation for Wind Load (East Wind)464

Figure 6.2.4-18 Section Deformation for Wind Load (West Wind).....465

Figure 6.2.4-19 Section Deformation for Tornado Load (North Wind)466

Figure 6.2.4-20 Section Deformation for Tornado Load (South Wind).....467

Figure 6.2.4-21 Section Deformation for Tornado Load (East Wind)468

Figure 6.2.4-22 Section Deformation for Tornado Load (West Wind)469

Figure 6.2.4-23 Section Deformation for Tornado Load (Differential Pressure).....470

Figure 6.2.4-24 Elements Selected for Tabulation (Wall below RCCV)471

Figure 6.2.4-25 Elements Selected for Tabulation (External Wall R1).....472

Figure 6.2.4-26 Elements Selected for Tabulation (External Wall R7/F1)473

Figure 6.2.4-27 Elements Selected for Tabulation (External Wall RA FA).....474

Figure 6.2.4-28 Elements Selected for Tabulation (Basemat).....475

Figure 6.2.4-29 Elements Selected for Tabulation (Slab at EL 4,650).....476

Figure 6.2.4-30 Elements Selected for Tabulation (Slab at EL 17,500).....477

Figure 6.2.4-31 Elements Selected for Tabulation (Slab at EL 27,000).....478

Figure 6.2.4-32 Elements Selected for Tabulation (Pool Girder).....479

Figure 6.2.4-33 Elements Selected for Tabulation (MS Tunnel Wall).....480

Figure 6.2.4-34 Elements Selected for Evaluation (IC/PCCS Pool in NS Direction).....481

Figure 6.2.4-35 Force and Moment in Shell Element.....482

Figure 6.4.1-1 Flow Chart of Design for Reinforced Concrete Structures483

Figure 6.4.1-2 Calculation of Shear Strength Provided by Concrete484

Figure 6.4.2-1 Allowable Stress of W-shaped Members (Strong Axis Bending)485

Figure 6.4.2-2 Allowable Stress of W-shaped Members (Weak Axis Bending).....486

Figure 6.4.2-3 Allowable Bending Stress of Box Members.....487

Figure 7.1-1 Reinforcing Steel of Foundation Mat: Plan488

Figure 7.1-2 Reinforcing Steel of Foundation Mat: Section A-A489

Figure 7.1-3 Reinforcing Steel of IC/PCCS Pool Girder.....490

Figure 7.1-4 List of RB Wall and Slab Reinforcement491

Figure 7.1-5 RB Roof Truss Structural Steel Member492

Figure 7.3.2-1 Elements Selected for Tabulation - RB Roof Truss and Supporting Column on R4
Column Line493



1. SCOPE

The objective of this report is to document the North Anna Unit 3 (NA3) site-specific structural design evaluation of the Economic Simplified Boiling Water Reactor (ESBWR) Reactor Building (RB) for the site-specific seismic load demands that exceed the seismic loads used for the standard design of the RB structure. The scope of the evaluation is the analysis and stress checks of the RB structure for site-specific seismic loads in combination with other design loads in critical seismic load combinations. The analysis is performed using the same NASTRAN model used for the standard design of the RB structure in Reference 2.1.2-e. The design loads applied to the model are the same as those considered in the standard design except for the site-specific Safe Shutdown Earthquake (SSE) loads that are obtained from Reference 2.1.2-k. The NA3 site-specific SSE loads are combined with non-seismic standard plant loads following the same standard design analysis methodology and acceptance criteria.

It should be noted that the Reinforced Concrete Containment Vessel (RCCV) is enclosed within the RB, but the design of the RCCV is out-of-scope of this report. The design results of the RCCV are described in WG3-T11-DRD-S-0001 "RCCV Structural Design Report," Reference 2.1.2-m. Stability checks are performed in WG3-U71-ERD-S-0003 "Reactor/Fuel Building Complex Stability Analysis Report," Reference 2.1.2-h.

2. APPLICABLE DOCUMENTS

2.1 Supporting and Supplemental Documents

2.1.1 Supporting Documents

	<u>MPL No.</u>
a. 26A6558, "General Civil Design Criteria", Revision 4	A40-4010
b. 26A6605, "Design Specification of Concrete Containment", Revision 4	T11-4010
c. 26A6606, "Design Specification for Reactor Building", Revision 2	U71-4010
d. 26A6608, "Design Specification for Fuel Building", Revision 2	U97-4010
e. 105E3908, "ESBWR Nuclear Island General Arrangement Drawing", Revision 5	A12-2010
f. RB FB Heat Transfer Analysis Report, Revision 3	A40-5010
g. eDRF Section 0000-0102-0965 R0, Deliverable to Structural Group for Steady State Heat Transfer and Stress Analysis	



2.1.2 Supplemental Documents

MPL No.

- a. 26A6642AL, "ESBWR Design Control Document Tier 2 Chapter 3 Appendices 3A – 3F", Revision 10
- b. 26A6642AN, "ESBWR Design Control Document Tier 2 Chapter 3 Appendices 3G – 3L", Revision 10
- c. DE-ES-0083, "Seismic Load Data for North Anna 3 from HGNE Analysis", Revision 0
- d. 26A6650, "ESBWR RCCV Structural Design Report", Revision 5
T11-5010
- e. 26A6651, "ESBWR Reactor Building Structural Design Report", Revision 5
U71-5010
- f. 26A6655, "ESBWR Fuel Building Structural Design Report", Revision 5
U97-5010
- g. WG3-U71-ERD-S-0001, "North Anna 3 Reactor/Fuel Building Complex Seismic Analysis Report", Revision 3
- h. WG3-U71-ERD-S-0003, "North Anna 3 Reactor/Fuel Building Complex Stability Analysis Report", Revision 1
- i. SER-DMN-011, "Benchmarking of SASSI2010 MSM Results from NA3 Site-Specific SSI Analysis", Revision 1
- j. TODI WG3-A25-TDI-S-0004, "North Anna 3 RB/FB, CB & FWSC SSI Analyses EPRI 2013 GMPE Based Inputs", Revision 0
- k. SER-DMN-019 "RB/FB Seismic Analyses Bounding Results and In-Structure Response Spectra", Revision 0
- l. 26A6661, "Structural Design Report for Containment Internal Structures", Revision 2, MPL No. T12-5010
- m. WG3-T11-DRD-S-0001, "North Anna 3 RCCV Structural Design Report", Revision 0
- n. WG3-U97-ERD-S-0001, "North Anna 3 FB Structural Design Report", Revision 0

2.2 Industry Codes and Standards

- a. ACI 349-01/349R-01: Code Requirements for Nuclear Safety Related Concrete Structures and Commentary
- b. ASME BPVC Sec III 2004: BPVC Section III, Division 2, Code for Concrete ASME BPVC Sec III 2004: BPVC Section III, Division 2, Code for Concrete.
- c. ANSI/AISC N690-1994 (R2004) & S2: Specification for the Design, Fabrication and Erection of Steel Safety-Related Structures for Nuclear Facilities and Supplement No. 2.
- d. ASCE 7-02: Minimum Design Loads for Buildings and Other Structures.
- e. ASCE 4-98: Seismic Analysis of Safety Related Nuclear Structures.



2.3 Regulation and Regulatory Requirements

- a. NUREG-0800 "Standard Review Plan for Review of Safety Analysis Reports for Nuclear Power Plants - LWR Edition", Revision 4.

2.4 References

- a. A Review of Procedure for the Analysis and Design of Concrete Structures to Resist Missile Impact Effects, R.P. Kennedy, Holmes and Narver, Inc. (Nuclear Engineering and Design article Vol. 37 1976, pages 183-203)
- b. Topical Report, Design of Structures for Missile Impact, Bechtel Power Corp., BC-TOP-9A Revision 2, September 1974
- c. Topical Report, Tornado and Extreme Wind Design Criteria for Nuclear Power Plants, Bechtel Power Corp., BC-TOP-3A, Revision 3, August 1974

3. STRUCTURAL DESCRIPTION AND GEOMETRY

3.1 Structural Geometry and Dimensions

The Reactor Building (RB) is a safety related and seismic category I structure. It shares a common basemat with the Reinforced Concrete Containment Vessel (RCCV) and the Fuel Building (FB). The RCCV is fully enclosed within the RB.

The RB is a rigid box shape building, and its key dimensions are summarized in Table 3.1-1. The key dimensions of the RCCV are summarized in Table 3.1-2. Floor plans and sections of the RB are shown in Figures 3.1-1 through 3.1-7.

3.2 Key Structural Elements and Descriptions

The RB structure consists of the following areas that are not part of the containment structure.

- The basemat is a reinforced concrete slab that functions as a common foundation for the R/B including RCCV and FB structures. Though the thickness of most of the basemat is 4.0m, the thickness is increased to 5.1m at the inside RPV pedestal and 5.5m at the bottom of the Spent Fuel Pool.
- RB super structure at and above the refueling floor, up to the support for the bridge crane, including the roof, is made of reinforced concrete floors and walls. Roof trusses and their supporting columns are made of structural steel.
- Passive Containment Cooling System (PCCS) and Isolation Condenser (IC) heat exchanger pools, the separator/dryer storage pool, the reactor cavity, the buffer pool, and including the standby liquid control pressure vessel rooms.



- Rooms at several elevation levels outside the containment but attaching to the containment structure.
- The main steam tunnel that consists of reinforced concrete walls and floor.

The RCCV structure boundary consists of the containment top slab with removable drywell head, the containment cylindrical wall that is also external wall of the suppression pool, the suppression pool floor slab, the RPV pedestal that encloses the volume under the RPV, and the basemat. The RCCV and the RB structure are integrated by the pool girders at the top of the containment and by floors at EL-6400, EL-1000, EL4650, EL9060, EL13570, EL17500 and EL27000. The configuration of the RCCV is shown in Figure 3.2-1.

Figure 3.2-2 shows the locations of various pools in the RB and FB.

The NA3 site-specific seismic demands for sliding stability can be solved without shear key as shown in the NA3 RB/FB Stability Analysis Report, Reference 2.1.2-h. Therefore, shear key design is not contained in this report. The same shear keys as described in Reference 2.1.2-e are provided under basemat for NA3.

3.3 Floor Layout and Elevations

Floor layouts and sections of the RB are shown in Figures 3.1-1 through 3.1-7. The RB is a nine-story building with rectangular shape floor plans. The RB structure is partially embedded with top of basemat 16.0 meters below grade.

3.4 Conditions of Vicinity and Support

In the ESBWR NA3 site-specific design, the buildings including the RB are designed under the condition that they are supported by the foundation soil that has the following properties corresponding to the Soft Site conditions described in Reference 2.1.2-e. The soft site conditions are conservative for NA3 rock site because softer soils lead to larger structural deformations.

- Shear wave velocity: 300 m/s
- Unit weight: 0.0196 MN/m³ (2.00 t/m³)
- Shear modulus: 180 MN/m² (1.835 x 10⁴ t/m²)
- Poisson's Ratio: 0.478

3.5 Special Structural Features

The RB has the following structural features.

- The RB is rigidly connected to the RCCV with pool girders and floor slabs. Therefore, it is necessary to consider the loads applied in the RCCV, such as pressure loads and thermal loads, for the structural design of the RB structures.



- Frame members are not installed in the RB except for roof trusses and steel columns which support trusses. The roof trusses and supporting columns are located at the stories above EL 34,000.

4. STRUCTURAL MATERIAL REQUIREMENTS

4.1 Concrete

The specified compressive strengths, f'_c , of the concrete at 28 days, or earlier, are as follows.

- Basemat: 27.6 MPa (4,000 psi)
- Top Slab: 41.4 MPa (6,000 psi)
- Others: 34.5 MPa (5,000 psi)

4.2 Reinforcement

Reinforcing steel is deformed billet steel conforming to ASTM A-615 grade 60. Minimum yield strength, F_y , is 413.6 MPa (60,000 psi).

4.3 Structural Steel

4.3.1 Carbon Steel Plate and Shapes

Structural steel and fasteners of the RB conform to the following:

- Structural Steel: ASTM A572 Gr.50 (for Column, Girder, etc.)
ASTM A36
- High strength bolts: ASTM A325 or A490
- Anchor bolts (rods): ASTM A36 or A307
- Steel floor decking: ASTM A446 with minimum $f_y = 228$ MPa (33 ksi)
- Studs: ASTM A108
- Pipe material: ASTM A333 Gr. 1 or 6, and A312 tp 304L or 316L
- Forgings: ASTM A 350 Gr. LF1 or LF2, and A182 Type F304L/316L

Steels used for the RCCV internal structures are as follows:

- Diaphragm Floor: ASTM A572 or A709 HPS 70W
- RPV Support Bracket: ASTM A516 or A709 HPS 70W
- Vent Wall: ASTM A572 or A709 HPS 70W
- GDSCS Pool: ASTM A572 or A709 HPS 70W



4.3.2 *Stainless Steel Plate*

Stainless steel plate or clad plate conform to ASTM A-240 Type 304L.

4.3.3 *Steel Decking*

Steel floor and roof decks conform to ASTM A446, Grade A, galvanized.

5. STRUCTURAL LOADS

As described later in Section 6.2, stress analyses of the RB are performed using a finite element (FE) analysis model that includes the RB, RCCV, and FB since they are integrated into one building. Therefore, in the following subsections, the loads applied to the RB as well as the RCCV and FB are described.

5.1 Live Loads and Dead Loads

5.1.1 *Dead Loads*

The following four kinds of dead loads are considered in the structural design of the RB.

Structural Weight

The weight of structures such as roof, floors, walls and steel framing (columns, girders and trusses) are calculated using the following unit weights.

- reinforced concrete: 23.5 kN/m³
- plain concrete: 22.5 kN/m³
- steel: 77.0 kN/m³

Miscellaneous Structures, Piping, and Commodity Loads

Table 5.1.1-1 shows the weights of the miscellaneous steels including roof trusses, finishings, and various pool liners in the RB and FB. The weights of liner inside the containment and hatch attached to the containment are shown in Table 5.1.1-2

Tables 5.1.1-3 and 5.1.1-4 show design loads of miscellaneous structures, piping, and commodities applied to the floor slabs and RCCV wall, respectively.

Equipment Loads

Weights of equipment located on the RB and FB slabs are summarized in Tables 5.1.1-5 and 5.1.1-6, and Figures 5.1.1-1 through 5.1.1-9. Please note that the building configurations in these Figures are not exactly consistent with the latest GA drawings.

Pool Water Hydrostatic Loads

The vertical and lateral pressures of liquids in pools are treated as hydrostatic loads on the walls and floors of pools. Table 5.1.1-7 lists the depths of pool water and the maximum design hydrostatic loads in the various pools.



5.1.2 Live Loads

The following three kinds of live loads are considered in the structural design of the RB.

Floor Live Loads

Table 5.1.2-1 shows the floor live loads distributed on the RB floor slabs. Floor live loads are reduced to 0.25 of their values when used in the evaluation of seismic loads. The live load inside the RCCV is zero since the containment is inaccessible. Floor live loads at the roof are enveloping snow load.

Snow Loads

Snow load for flat roof is taken as 2.4 kN/m² (50 psf), uniformly. For the lower roofs, i.e., RB roof at EL 34,000 and FB roof at EL 27,500, the snow drift load are additionally considered as shown in Figure 5.1.2-1. Their values are calculated based on ASCE 7-02, Reference 2.2-d.

Lateral Soil Pressure

The static lateral soil pressure loads, which are shown in Table 5.1.2-2, are applied to the external walls below grade. Evaluations of lateral soil pressures are described in Appendix B in Reference 2.1.2-e. The at-rest lateral pressures are for generic sites considered in the standard design and they are larger than the NA3 site-specific static lateral pressures and conservatively used for NA3.

5.2 Transient Loads

5.2.1 Pressure Loads

5.2.1.1 Containment Pressure Loads

The containment pressure loads that act on the inner surfaces of the RCCV and IC/PCCS pools during normal operation, tests, and a LOCA are considered. Figure 5.2.1-1 show the transient curves representing the pressure envelopes for the design basis accident (DBA). Figure 5.2.1-2 show the regions where the pressure loads are applied in the IC/PCCS pools.

The following events are considered for determining the design pressure loads. Table 5.2.1-1 shows their values.

1. Normal operation
2. Test – maximum internal pressure
3. Test – maximum differential pressure
4. LOCA – 5 seconds after DBA
5. LOCA – 6 minutes after DBA
6. LOCA – 10 hours after DBA



7. LOCA – 72 hours after DBA

The pressure loads during a LOCA are defined for various times after an accident and are determined from time history curves of temperature and pressure conditions for several parts of the RCCV. Table 5.2.1-2 gives the reasons why the above four (4) LOCA times are selected.

5.2.1.2 High Energy Line Break (HELB) Loads

The pressure loads due to high energy line break (HELB) is as follows.

- Main Steam Tunnel : 76.0 kPag (11 psig)
- RWCU / Shutdown Cooling Valve Rooms A thru D, RWCU / Shutdown Cooling Heat Exchanger Rooms A thru D, Corridors A thru D and Commodity Chases A thru D: 34.5 kPag (5 psig)
- All Other Rooms in RB and FB Outside Containment: 14.0 kPag (2 psig)

5.2.2 Thermal Loads

5.2.2.1 Normal Temperatures (To)

The following operational states are considered for determining the normal thermal loads. Table 5.2.2-1 shows the steady state temperature conditions for each of the following states and for each part of the RB.

1. Normal operation – Summer and Winter

The thermal loads are specified, for stress analyses, as average temperatures, T_d , and temperature differences, T_g . They are in turn obtained from equivalent linearization of heat transfer analysis results. For normal temperatures, steady state heat transfer analyses are performed using the temperature conditions shown in Table 5.2.2-1.

The stress-free design temperature used in the stress analyses is 15.5 °C.

As for heat transfer analyses, refer to A40-5010 “RB FB Heat Transfer Analysis Report.”

5.2.2.2 Accident Temperatures (Ta)

The following conditions are considered for defining the accident thermal loads. The conditions are determined from time history curves of temperatures and pressures at several parts of each structure.

(1) RCCV

Figures 5.2.2-1 and 5.2.2-2 show the envelopes of transient temperatures during a LOCA.

1. LOCA – 5 seconds after DBA, Summer and Winter
2. LOCA – 6 minutes after DBA, Summer and Winter



3. LOCA – 10 hours after DBA, Summer and Winter

4. LOCA – 72 hours after DBA, Summer and Winter

The reasons why the above events are selected as the design loads are described in Table 5.2.1-2.

The structural evaluation for TRACG, GEH proprietary version of the Transient Reactor Analysis Code, calculated LOCA temperature provided in Reference 2.1.1-g is described in Appendix E of ESBWR Reactor Building Structural Design Report, Reference 2.1.2-e, including the thermal loads for surrounding area of RB upper pool.

Four cases of temperature distributions in the upper pool at 72 hours after LOCA are shown in Figure 5.2.2-3

(2) Spent Fuel Pool

Table 5.2.2-2 shows the envelopes of transient temperatures in the spent fuel pool during a DBA.

1. Normal operation

2. DBA – 72 hours after DBA due to loss of Fuel and Auxiliary Pools Cooling System (FAPCS) cooling function

Because the temperature in the spent fuel pool reaches its maximum values at this time, the above events are selected as the design loads.

Determining the accident thermal loads follows the same procedure as that described for normal thermal loads in Subsection 5.2.2.1. The only difference is that non-steady state heat transfer analyses are performed for accident temperature conditions instead of steady state analyses.

5.2.3 Hydrodynamic Loads

5.2.3.1 Safety/Relief Valve (SRV) Loads

The SRV loads are hydrodynamic loads resulting from the discharge of the safety/relief valves. Figure 5.2.3-1 shows the load values and the regions in the RCCV where the SRV loads are applied.

The SRV design loads are determined, taking their dynamic characteristics into account, by multiplying the load values by dynamic load factors (DLFs), which are shown in Figure 5.2.3-1. The adequacy of DLF equal to 2.0 is confirmed by dynamic response analysis.

5.2.3.2 Chugging (CH) Loads

The chugging loads are hydrodynamic loads that are applied to the suppression chamber during a LOCA. Figure 5.2.3-2 shows the event-time relationship during a DBA.



Figure 5.2.3-3 shows the regions where the chugging loads are applied, the load values, and the DLFs. The adequacy of DLF equal to 2.0 is confirmed by dynamic response analysis.

5.2.3.3 Condensation Oscillation (CO) Loads

The CO loads are, like the chugging loads, hydrodynamic loads that are applied to the suppression chamber during a LOCA. Figure 5.2.3-4 shows the regions where the CO loads are applied, the load values, and the DLFs.

5.2.3.4 Pool Swell

The pool swell loads are, like the CH and CO loads, hydrodynamic loads that are applied to the suppression chamber during a DBA. The peak Pool Swell (PS) dynamic pressure in the air space of the suppression pool is 350kPa (i.e., 246 kPag (36 psig)). The dynamic load factor is 1.0. These PS boundary pressures shall be applied together with a drywell pressure of 414 kPa (i.e., 310 kPag (45 psig)) such that the pressure differential between the drywell (DW) and the wetwell (WW) is 64 kPad (9 psid) as wetwell gas space is at its peak pressure during PS. The pressure distribution is shown in Figure 5.2.3-5.

Note: The unit kPa without (d) or (g) means absolute.

Containment structures shall be analyzed for the following cases involving pool swell pressure, froth impact and fallback drag loads.

Case 1. Pool swell occurs with pressures without froth impact and fallback drag loads. Containment structures are to be analyzed for pool swell pressure with pressure distribution shown in Figure 5.2.3-5.

Case 2. Pool swell occurs with pressures in conjunction with froth impact and fallback drag loads. Containment structures are to be analyzed for two cases involving pool swell pressure, froth impact and fallback drag loads.

Case 2a. Wet well and bubble pressures defined in Figure 5.2.3-6 together with the froth impact pressure (DLF = 1.60) acting on the bottom face of diaphragm floor and bottom face of the bottom flange of radial beams.

Case 2b. Wet well and bubble pressures defined in Figure 5.2.3-6 together with the fallback drag pressure (DLF = 1.0) acting on the top face of the bottom flange of the radial beams of diaphragm floor.

The worst results or the enveloping values of these cases will be used as the Pool Swell (PS) values to be combined with other loads in the load combinations.

5.2.4 RPV Reactions due to Hydrodynamic Loads

Reactions of the Reactor Pressure Vessel (RPV), which are applied to the RPV support bracket and the RPV stabilizer, and the GDSC pools during the SRV discharge and LOCA are regarded as hydrodynamic loads in the RCCV design. The RPV reactions due to SRV loads and LOCA loads are shown on Table 5.2.4-1.



5.3 Environmental Loads

5.3.1 Wind Loads

Design conditions for calculating the basic wind load are as follows.

Basic wind speed (50 year recurrence interval), m/s (mph)	62.6 (140)
Importance Factors (Safety-related structures)	1.15
Exposure Category	Exposure D

Wind load values at each floor level are shown in Table 5.3.1-1. They are evaluated in accordance with ASCE 7-02, Reference 2.2-d, using the design conditions mentioned above. The evaluation of design wind loads is described in Appendix B in Reference 2.1.2-e.

5.3.2 Tornado Loads

Design conditions for calculating the tornado wind load are as follows.

Maximum Tornado wind speed, m/s (mi/hr)	147.5 (330)
Maximum Rotational Speed, m/s (mi/hr)	116.2 (260)
Maximum Translational Speed, m/s (mi/hr)	31.3 (70)
Radius, m (ft)	45.7 (150)
Maximum Pressure Drop, kPa (psi)	16.6 (2.4)
Maximum Rate of Pressure Drop, kPa/s (psi/s)	11.7 (1.7)

Tornado load values at each floor level are shown in Table 5.3.2-1. They are evaluated in accordance with BC-TOP-3A, Reference 2.4-c, using the design conditions mentioned above. The evaluation of design tornado loads is described in Appendix B in Reference 2.1.2-e.

5.3.3 Seismic Loads

The seismic loads considered in the RB design are those generated by the site specific SSE. They are applicable to all seismic load combinations including those for LOCA flooding inside the containment.

The design seismic loads are determined from the site-specific soil-structure interaction (SSI) analysis results, which are described in Reference 2.1.2-g "North Anna 3 Reactor/Fuel Building Complex Seismic Analysis Report." Four components - two horizontal, one



vertical, and one torsional - of the seismic loads are evaluated following the methodology used for the standard design of the RB in Reference 2.1.2-e. The out-of-plane loads due to horizontal SSE acceleration are considered as one of the horizontal components at walls, whose out-of-plane natural frequency is less than 50 Hz.

The analysis cases of the RB/FB seismic analyses used to form the bounding NA3 site-specific seismic demands for this report are presented in Table 3-1 of Reference 2.1.2-k. These loads bound the effects of stiffness variation as described in Reference 2.1.2-g.

The site-specific seismic design loads applied to the RB, FB, and RCCV structures are shown in the following tables. Node numbers in the tables are described in Figure 5.3.3-1.

- Horizontal seismic loads and torsion: Tables 5.3.3-1 through 5.3.3-5
- Vertical seismic loads: Tables 5.3.3-6 through 5.3.3-10
- Out-of-plane accelerations at walls: Table 5.3.3-19

The equivalent out-of-plane acceleration loads on slabs and walls are based on Tables 4.5-1 and 4.5-2 of Reference 2.1.2-k. The details of calculation of the equivalent out-of-plane acceleration loads on slabs and walls are shown in Appendix D of Reference 2.1.2-g.

The following loads are also regarded as seismic loads, and are considered in the RB design.

Soil pressure due to an earthquake

The design soil pressure loads due to SSE are calculated from SSI analysis results. Design loads are shown in Table 5.3.3-11. These loads are determined by enveloping the soil pressure calculated directly from SSI analysis.

Since the NA3 site-specific passive pressures required for stability evaluations in Reference 2.1.2-h are bounded by the standard design wall capacity pressures, the wall capacity evaluation is not performed.

Hydrodynamic loads in pools

Hydrodynamic loads in pools due to SSE are considered. Tables 5.3.3-12 through 5.3.3-17 show the loads applied to walls and slabs, and the locations of pools are shown in Figure 5.3.3-2. The detail of the calculation of these sloshing loads is shown in Appendix A of Reference 2.1.2-k.

RPV reactions due to an earthquake

RPV reactions due to an earthquake are regarded as a part of seismic loads in the RB and RCCV design. The values are summarized in Table 5.3.3-18. The reactions are applied to the RPV support brackets.

6. STRUCTURAL ANALYSIS AND DESIGN

6.1 General Description

The structural analysis and design of the RB are performed according to the following



procedure.

1. Prepare a finite element (FE) model for stress analyses considering structural characteristics and materials.
As stated in Section 3.1, the RB including RCCV and the FB are integrated into one building in the ESBWR plant. Therefore, the FE model includes the RCCV, RB, and FB (RB/FB global FE model).
2. Perform stress analyses for the design loads described in Chapter 5, and calculate the section forces.
3. Select the basic and critical load combinations as the selected design load combinations for the RB design.
4. Combine the section forces according to the selected design load combinations mentioned in Step 3 above, which are described later in Section 6.3.
5. Perform structural design calculations using the section forces for the selected design load combinations.

The design/evaluation is essentially performed using ASME, Section III, Division 2. The details of the design/evaluations and the exceptions to the use of ASME, Section III, Division 2 are described in Section 6.4.1.

The design of steel structures in the RB is performed in accordance with ANSI/AISC N690-1994 "Specification for the Design, Fabrication, and Erection of Steel Safety-Related Structures for Nuclear Facilities," with the Supplements No.1 (2002) and No.2 (2004).

6.2 Stress Analysis

6.2.1 Analysis Program

The computer program used for the stress analysis calculations is NASTRAN Version 2013.0.0. It is a general-purpose stress analysis program, which is technically based on the finite element method. Analysis calculations are executed on Red Hat Enterprise Linux Server release 5.7 OS.

6.2.2 Analysis Model

6.2.2.1 Outline of the Analysis Model

Major structural members of the RB and the FB, which are shown in Figures 3.1-1 through 3.1-7, include the basemat, RCCV, floor slabs, external walls, shear walls, and frame members. FE models are employed considering the complexity of the structure, load conditions, and boundary conditions.

Figures 6.2.2-1 and 6.2.2-2 show the RB/FB global FE analysis model used for the RB design. The model includes the whole (360°) portion of the RB including the RCCV and FB taking the application of nonaxisymmetrical loads and the asymmetric layout of the FB



structure into consideration.

Structures of the FB located above EL 22,500 are not included in the model, because they are Seismic Category II structures. (Refer to Figure 3.1-6.)

Besides building structures, the global FE model includes the major RCCV internal structures, i.e., the vent wall, the diaphragm floor slab, the GDCS pool, the reactor shield wall, and the RPV support brackets. In addition, steel liner plates installed at the inside surface of the RCCV are included in the model. They are shown in Figures 6.2.2-3 and 6.2.2-4.

As described in Appendix E to Reference 2.1.2-e, the original global finite element model was updated for the standard design to reflect current pool gate design and design changes in the upper pools as required to meet design acceptance criteria for stresses resulting from temperature variations in the RB upper pool after a DBA. This updated standard plant model is applied for the following unit load analysis cases for NA3.

- Dead Load
- Pressure Load at Drywell, IC/PCCS Pools, HELB in MS Tunnel and Wetwell
- Temperature Loads in RB upper pools after LOCA shown in Figure 5.2.2-3.
- Seismic load for NA3 site-specific conditions

For other unit load cases, the original global finite element model is used because these loads are not influenced by the design changes in the upper pools.

6.2.2.2 Modeling Principles

The global FE model is developed according to the following modeling principles.

1. The FE stress analysis model is a whole structure of the RB including the RCCV and the FB.
2. The following major penetrations in the RCCV are included in the model in order to take local reduction of the wall stiffness into consideration.
 - upper drywell equipment and personnel hatches
 - lower drywell equipment and personnel hatches
 - suppression chamber access hatch
 - main steam and feedwater pipe penetrations.
3. The analysis model is developed based on the General Arrangement drawings listed in Table 6.2.2-1.
4. Primary structural members, including the RCCV, basemat, pool structures, shear walls, and floor slabs are modeled so that their design section forces are adequately evaluated. Table 6.2.2-2 lists which structural members are included in the FE model and which ones are designed using the section forces obtained by the global model



analyses. Table 6.2.2-3 shows the types of finite elements used to model various structural members. It also shows the section forces each type of element can account for.

5. The global coordinate system of the analysis model is determined as follows.
 - Origin: The origin is on EL 0,000 at the center of the RCCV.
 - X-axis: Positive X is in the southward direction from the origin.
 - Y-axis: Positive Y is in the eastward direction from the origin.
 - Z-axis: Positive Z is in the vertically upward direction.
6. Table 6.2.2-4 shows the z-direction in local coordinate systems of major structures. These information are used to define directions of applied loads, such as pressure and thermal loads.

6.2.2.3 Modeling of the Basemat and Ground

Basemat

As shown in Tables 3.1-1 and 3.1-2, the thickness of the basemat is 4.0 m in general, and is increased to 5.1m at the RCCV portion and 5.5m at the Spent Fuel Pool portion.

The elements are placed horizontally at the center of the basemat. The R7 column line marks the division between the RB and FB. In addition, the basemat inside the RPV pedestal are treated as a part of the RCCV.

Figure 6.2.2-5 shows the finite element model of the basemat. Figure 6.2.2-6 is an enlarged figure of the basemat inside the containment. They show finite element meshes, grid IDs, element IDs, element property IDs (PIDs).

Ground

The ground is modeled with spring elements. Three independent spring elements, one vertical and two horizontal, are attached to each of the basemat grid points.

Spring constants are calculated using the soil properties shown in Section 3.4. Table 6.2.2-5 shows the vertical and horizontal spring constants per a unit area. The constants are calculated based on soil spring constants of the Sway-Rocking model for standard plant SSI analyses. These soil springs are for soft site conditions considered for the standard plant design and they are conservative for NA3 rock site because softer soils lead to larger structural deformations.

The ground is assumed to be elastic, and the basemat uplift during an earthquake is not considered in the stress analysis calculations. Uplift evaluation described in Section 5.6 of Reference 2.1.2-g demonstrates that the possible uplift of the RB/FB basemat has negligible effect on the RB/FB seismic responses that are performed on linear elastic models.



6.2.2.4 Modeling of the RCCV

RCCV Cylinder Wall

The RCCV cylinder wall is modeled with shell elements that are 2.0 m thick. The elements are placed vertically at the center of the wall, $R = 19.0$ m. The wall is divided, in general, into 48 elements in the circumferential direction (7.5° pitch) and into 3 or 5 elements vertically per a story. The modeled region of the RCCV wall is between the center of the suppression pool slab, EL 3,650, and the center of the top slab, EL 25,800. The cylindrical wall below RCCV cylinder wall, from EL -11,500 to EL 3,650 is shear wall that connects the RCCV cylinder wall and basemat.

The levels of floor slabs connected to the RCCV wall are determined as shown in Table 6.2.2-6. They are so determined that the slabs connected to the RCCV are located at their centers of thicknesses.

The major penetrations in the concrete containment are included in the model in order to take local reduction of the wall stiffness into consideration. Their dimensions and locations are shown in Table 6.2.2-7.

Figure 6.2.2-7 shows the finite element model of the RCCV cylinder wall including the wall below the RCCV.

RPV Pedestal Wall

The RPV pedestal wall is modeled with shell elements that are 2.4 m thick, whereas its actual thickness is 2.5 m as shown in Table 3.1-2. The thickness is conservatively reduced considering that the concrete section is decreased by thick steel plates at the connection with the RPV support brackets.

The elements are placed vertically at the center of the cylinder wall, $R = 6.8$ m. The wall is divided, in general, into 48 elements in the circumferential direction (7.5° pitch) and into 3 elements vertically per a story. The modeled region of the RPV Pedestal wall is between the upper surface of the basemat, EL -11,500, and the center of the suppression pool slab, EL 3,650.

The openings included in the RPV pedestal model are shown in Table 6.2.2-7.

Figure 6.2.2-8 shows the finite element model of the RPV pedestal wall.

Top Slab

The top slab is modeled with shell elements that are 2.4 m thick. The elements are placed horizontally at the center of the top slab, EL 25,800. Elements are, in principle, divided in X- and Y-directions considering the direction of rebar arrangements.

Figure 6.2.2-9 shows the finite element model of the top slab.

Suppression Pool Floor Slab

The suppression pool floor slab is modeled with shell elements that are 2.0 m thick. The elements are placed horizontally at the center of the suppression pool floor slab, EL 3,650. Elements are divided in radial and circumferential directions considering the direction of



rebar arrangements.

Figure 6.2.2-10 shows the finite element model of the suppression pool floor slab.

6.2.2.5 Modeling of the RCCV Liner and Sleeves

RCCV Liner

The steel liner plates that are attached to the basemat and the RCCV are modeled with shell elements. The liner elements are divided in the same way as the corresponding concrete elements.

The materials and thicknesses of the RCCV liners are summarized in Table 6.2.2-8. Figures 6.2.2-11 through 6.2.2-15 show the finite element models of the liners. It should be noted that the liner plates at the following locations are the parts of the RCCV internal model described later in Subsection 6.2.2.10. Therefore, they are not shown in Figures 6.2.2-11 through 6.2.2-15.

- RCCV wall – diaphragm floor slab joint
- RPV pedestal – vent wall joint

Rigid bar elements connect the corresponding grid points of the liner elements and concrete elements as shown in Figure 6.2.2-16. Rigid bar elements are placed in the radial direction for the liners of the RCCV cylinder wall and the RPV pedestal. They are placed vertically for the basemat, the suppression pool slab, and the top slab.

Sleeves

Sleeve attached to RCCV top head openings are modeled with rod elements. Table 6.2.2-9 shows the areas of modeled rod elements. Finite element models of the sleeves are shown in Figure 6.2.2-17.

6.2.2.6 Modeling of the RB Pools and MS Tunnel Structures

The pool structures in the RB include walls and slabs of the reactor cavity pool, the dryer/separator pool, the fuel buffer pool, IC/PCCS pool, the IC/PCCS expansion pool, and the GDCS pool. The modeled pool walls except the external walls are shown in Figure 6.2.2-18.

The walls and slabs of the Main Steam (MS) tunnel room is included in the analysis model in order to estimate the section forces due to the HELB load in the MS tunnel room.

The pool girders, reactor well walls, pool walls, pool slabs, and the MS tunnel walls and slabs are modeled with shell elements.

Finite element models of the pool girders are shown in Figure 6.2.2-19.

6.2.2.7 Modeling of Shear Walls

The following walls are included in the global analysis model.



- External walls including the wall on R7/F1 column line
- Walls above EL 34,000 and on R2 and R6 column lines
- Wall below RCCV cylinder wall
- Inner walls indicated in Figures 6.2.2-20 through 6.2.2-22

The external walls are modeled with shell elements that are placed vertically on the center of each wall at the lowest story. The regions of the external walls which are modeled are between the top of the basemat, EL -11,500, and the top of each wall. They are divided horizontally at the same locations as those of the basemat grid points, and vertically into, in principle, three or five elements in each story. Finite element models of the external walls are shown in Figures 6.2.2-23 through 6.2.2-27. The considered openings are shown in Table 6.2.2-10.

The wall below RCCV cylinder wall is shown in Figure 6.2.2-7.

The inner walls are modeled at appropriate locations. They are modeled with shell elements in the same way as the external walls.

Rigid bar elements connect the basemat and the bottom of the shear walls as described in the modeling of the RCCV liner.

6.2.2.8 Modeling of Floor Slabs

The floor slabs are modeled with shell elements which are divided in the same way as the basemat. Major large openings are included in the model.

The elements of slabs that are connected to the RCCV are placed horizontally at the levels described in the modeling of the RCCV wall. Elements of the slabs which are located above the top slab level are positioned at corresponding floor levels.

Finite element models of the major floor slabs are shown in Figures 6.2.2-28 through 6.2.2-30.

6.2.2.9 Modeling of Frame Members

Frame members included in the global stress analysis model are columns, girders, and the main trusses of the roof truss. They are modeled with bar elements.

Roof trusses and roof slabs are connected rigidly. Steel girders attached to the reinforced concrete columns, like steel girders at the FB roof, are simply supported at the ends of the girders.

Figures 6.2.2-31 through 6.2.2-36 show finite element models of frame members.

6.2.2.10 Modeling of the Containment Internal Structures

The RCCV internal model is described in detail in another report, T12-5010 "Structural Design Report for Containment Internal Structures", Reference 2.1.2-1. Therefore, its outline



is briefly explained here.

The vent wall and the diaphragm floor are concrete-filled structures consisting of steel plates and concrete. The infill concrete is neglected in analysis model conservatively. Steel plates including connecting rib plates and girders are modeled by shell elements.

The GDCS pool, the reactor shield wall, and the RPV support brackets are also included in the analysis model. These structures are modeled by shell elements except the GDCS pool beams which are modeled by beam elements. The analysis model of these structures is shown in Figure 6.2.2-4.

6.2.2.11 Units and Material Constants

Stress analyses are executed with the following SI units.

- length: m
- force: MN
- moment: MN-m
- pressure: MPa
- temperature: °C

The material constants shown in Table 6.2.2-11 are used for the stress analysis calculations.

The Young's modulus for concrete used in the thermal load analysis is reduced depending on the average temperature of each element, as described in Note 2 of Table 6.2.2-11. Young's modulus for the RCCV steel liners is set to a small value, 1/10000 of the normal value, in analysis calculations of non-thermal loads so that they do not bear any stresses.

6.2.2.12 Boundary Conditions

Because the RB/FB global FE model is a whole (360°) model, only soil springs under the basemat are used as a boundary condition.

6.2.3 Method of Applying Loads

Load application methods in the global FE analyses are described in the following subsections. However, as for the loads applied to the RCCV internal structures, their application methods are described in another report, T12-5010 "Structural Design Report for Containment Internal Structures", Reference 2.1.2-1. Therefore, they are not referred in this report, in principle.

6.2.3.1 Dead Load

Weight of Modeled Structural Members

The weights of reinforced concrete members included in the analysis model are evaluated using GRAV feature that NASTRAN provides. It applies a downward gravity force to each



element mass which is calculated from the weight density and the volume of the element.

Evaluation of the structural weights using GRAV has one drawback, which is double counting of weights at such regions as wall-wall and wall-slab corners and edges of girders and columns. These double counts are ignored in the analysis, however, for the following reasons. Duplicated weights of corners are negligibly small compared to the total weight of the analysis model. The increased weights of girders lead to a design with larger margins.

Roof trusses and steel girders are included in the analysis model but their weights are evaluated differently. Their evaluation and the methods of applying them are explained below together with those of structural members which are not modeled.

Weights of Not-Modeled Structural Members

The weights of roof trusses, steel beams, permanent steel girders, which are included in the model, decks, and deck beams are applied to slab elements as distributed surface loads.

The weights of finishings for slabs and external walls and the weights of liners not included in the FE model are also applied as distributed loads.

Unit area loads applied to the analysis model are described in Table 5.1.1-1.

Miscellaneous Structures, Piping, and Commodities

The weights of the miscellaneous structures, the piping, and commodities on the floor slabs and the containment are applied as distributed surface loads to the floor slab elements and containment wall, respectively.

Values of loads mentioned above are indicated in Tables 5.1.1-2 through 5.1.1-4.

Equipment Weights

The distributed surface loads of equipment weights are calculated from weights and areas of equipment shown in Tables 5.1.1-5 and 5.1.1-6 and Figures 5.1.1-1 through 5.1.1-9, and are applied to the floor slab elements and nodes.

The calculated equipment load values and their regions are shown in Figures 6.2.3.1-1 through 6.2.3.1-10.

The weights of crane, RB crane, refueling machine, FB crane, and fuel handling machine, are transmitted via crane girders to four supporting columns around the crane as vertical force and bending moment. So they are applied as nodal forces to the edge of rigid link elements that are modeled to evaluate the effect of the distance from column to the crane wheels on the girder. The crane is assumed to be positioned center of crane girders. The lifted loads are evaluated in the same manner of the crane weights, but they are applied to two columns of one side, conservatively.

Hydrostatic Loads

Hydrostatic loads due to the pool water act on the pool walls and slabs. Figures 6.2.3.1-11 through 6.2.3.1-35 show the regions where the hydrostatic pressure loads are applied, together with their values. For each element in the regions, the pressure at the center of gravity of the element is applied as a uniform pressure load.



As for the hydrostatic loads on the RCCV top head, equivalent nodal forces are applied to the grid points around the top head opening as shown in Figure 6.2.3.1-14.

6.2.3.2 Live Load

Floor Live Loads

Floor live loads except for roofs are applied to modeled slab elements as uniformly distributed surface loads. Applied load values are described in Table 6.2.3.2-1. Floor live load for roofs are enveloping the snow load as shown in Table 6.2.3.2-1 and Figure 6.2.3.2-1.

For the FB, floor live loads should be applied to the roof slab at EL 27,500. However, the FB structures above EL 22,500 are not included in the global FE model because they are Seismic Category II structures. Therefore, snow loads are applied as nodal forces to the slab at EL 22,500 as shown in Figure 6.2.3.2-2. Loads are applied to the nodes at the positions of columns supporting the roof slab.

Lateral Soil Pressure Load at Rest

The lateral soil pressure at rest is applied to the external walls below grade. The static lateral soil pressure loads are for generic sites considered in the standard design and they are larger than the NA3 site-specific static lateral pressures and conservatively used for NA3. Figures 6.2.3.2-3 through 6.2.3.2-7 show the values and regions where the soil pressure loads are applied.

For each element in the regions, a pressure at the center of gravity of the element is applied as a uniformly distributed pressure load. Soil pressure loads that act on the side of the basemat are applied as equivalent horizontal forces to nodes on the basemat edges as shown in Figure 6.2.3.2-3. Bending moments generated by differences of pressures at the top and bottom of the basemat are also applied to basemat nodes as shown in Figure 6.2.3.2-3.

Snow Loads

The snow loads are applied to the roof slab. However, since the snow load on the RB roof at EL 52,700 is less than floor live load, it is neglected.

For the RB roof at EL 34,000 and the FB roof, snow loads rather than floor live loads should be applied to the roof slab at each level as shown in Figure 6.2.3.2-1.

6.2.3.3 Pressure Load

Containment Pressure Loads

Analysis calculations are performed for two unit pressure, 1.0 MPa, that are applied to the Drywell and Wetwell, respectively. The corresponding regions are shown in Figures 6.2.3.3-1 and 6.2.3.3-2. Table 6.2.3.3-1 indicates the load combinations to achieve the design pressure loads based on unit pressures. The table contains the combinations for IC/PCCS pool pressure load and HELB loads in the MS tunnel, too.

Figures 6.2.3.3-3 through 6.2.3.3-6 show the regions for the Drywell unit pressure load, and Figures 6.2.3.3-7 and 6.2.3.3-8 show those for the Wetwell unit pressure load.



IC/PCCS Pool Pressure Load

Analysis calculations are performed for a unit pressure, 1.0 MPa, applied to the IC/PCCS pool and IC/PCCS expansion pools. The corresponding regions are shown in Figure 5.2.1-2.

Figures 6.2.3.3-9 through 6.2.3.3-20 show the regions where the IC/PCCS pool unit pressure loads are applied.

High Energy Line Break Loads

Analysis calculations are performed for a unit pressure, 1.0 MPa, applied to the MS tunnel and the general rooms. The HELB loads for the general rooms of the RB and the FB are considered at the walls and roofs, which compose the superstructure above EL 34,000 and EL 4,650 respectively, as a significant impact portion.

Figures 6.2.3.3-21 through 6.2.3.3-24 show the regions for the HELB loads for the MS tunnel. Figures 6.2.3.3-25 through 6.2.3.3-33 show the regions for the HELB loads for the general rooms.

6.2.3.4 Thermal Load

Thermal loads are determined as follows based on heat transfer analysis results, which are described in A40-5010 "RB FB Heat Transfer Analysis Report."

Concrete Walls and Slabs

The average temperature, T_d , and the surface temperature difference, T_g , that are obtained by heat transfer analyses are applied to shell elements.

For the thermal loads during LOCA and LOCA flooding, the following three conditions are considered depending on the GDCS pools water depth. Condition 2 and 3 are performed assuming conservative case that there is no water in the GDCS pool.

- Condition 1; GDCS pool water depth is 4410 mm
- Condition 2; GDCS pool water depth is 792 mm
- Condition 3; GDCS pool water depth is 792 mm (during LOCA Flooding)

Tables 6.2.3.4-1 and 6.2.3.4-2 show atmosphere temperature. Table 6.2.3.4-3 and Figures 6.2.3.4-1 through 6.2.3.4-30 show the regions where the various thermal loads are applied to the shell elements. Tables 6.2.3.4-4 through 6.2.3.4-13 and Tables 6.2.3.4-17 and 6.2.3.4-18 summarize the thermal load values for each operational state and each region.

The thermal load values obtained from heat transfer calculation for updated upper pool temperature distribution using the conditions described in Appendix E of Reference 2.1.2-e are shown in Tables 6.2.3.4-19 through 6.2.3.4-22. These 4 analysis cases are summarized below.

Case 1: Maximum, temperatures in all pools are at their respective maximum values

Case 2: Minimum, temperatures in all pools are at their respective minimum values.



Case 3: Mixed, temperatures in individual pools are at either maximum or minimum values.

Case 4: Lower bound, temperatures in all pools are at 0°C

Tg of a shell element is positive if the surface in the positive z-direction in the local coordinate system has the higher temperature.

Beams, Girders and Columns

The frame members are modeled by bar elements.

Beams, girders and columns located inside buildings are exposed to the uniform and steady temperature of the RB/FB rooms. Therefore, the thermal loads for the elements of these members are so determined that the average temperature Td is equal to the room temperature (summer 40 °C, winter 10 °C) and the surface temperature difference Tg is 0.0.

On the other hands, as for the reinforced concrete columns located in external walls, their thermal loads are set to be same as those of walls with the modifications described in Table 6.2.3.4-14.

Table 6.2.3.4-14 shows the thermal loads and indexes applied to concrete girders and columns. Figures 6.2.3.4-31 through 6.2.3.4-36 show the positions and thermal load indexes of concrete girder and columns. The thermal loads for rigid link elements of steel beams and columns are set to be same as the room temperatures.

RCCV Liner, Sleeves

The RCCV atmosphere temperature is used as average temperature, Td. In each case, the surface temperature difference, Tg, is set to be 0.0 °C. Temperature loads applied to the RCCV liners are included in Tables 6.2.3.4-4 through 6.2.3.4-13.

Table 6.2.3.4-15 shows the thermal loads applied to the sleeve at the RCCV top head opening modeled by rod elements.

Table 6.2.3.4-16 shows the load labels of the design thermal loads.

6.2.3.5 Hydrodynamic Loads

Analysis calculations are performed using the loads and the dynamic load factors (DLFs) given in Figures 5.2.3-1 and 5.2.3-3 through 5.2.3-6.

Figures 6.2.3.5-1 through 6.2.3.5-20 show the values and regions to which the hydrodynamic loads are applied. Hydrodynamic loads acting on the inner surface of the RCCV are applied to the liner elements as uniformly distributed pressure loads. The pressure value applied to each element is calculated at the center of gravity of the element.

6.2.3.6 Reaction Loads due to Hydrodynamic Loads

The RPV and GDCS pool wall reactions during LOCA are applied only to the RCCV internal structures. For details of the load application methods, refer to T12-5010 "Structural Design Report for Containment Internal Structures", Reference 2.1.2-1.



6.2.3.7 Wind Loads

Loads for four wind directions, east, west, south and north wind, are considered. Tables 6.2.3.7-1 through 6.2.3.7-4 show the applied pressures.

Wind pressure loads acting on walls and slabs are applied to shell elements as uniform pressure loads. The pressure value applied to each element is calculated at the center of gravity of the element.

6.2.3.8 Tornado Loads

Analyses for the tornado wind load is performed using the same method as the design wind load.

Loads for four wind directions, east, west, south and north wind, and differential pressure loads are considered. Tables 6.2.3.8-1 through 6.2.3.8-5 show the applied pressures.

6.2.3.9 Seismic Loads

As for seismic loads, analyses are performed for the loads listed in Table 6.2.3.9-1. The seismic loads for normal operation & LOCA condition are the same seismic loads for LOCA flooding condition.

6.2.3.9.1 Seismic Loads for the RB, RCCV, and FB

The seismic forces applied to the analysis model are determined from the design seismic loads shown in Tables 5.3.3-1 through 5.3.3-10 and 5.3.3-19. Four components, two horizontal including out-of-plane loads to walls, one vertical, and one torsional of the seismic loads are evaluated. The directions in which they are applied are shown schematically in Figure 6.2.3.9-1.

The methods of applying the forces are described below for each of the components.

Shear Forces

Calculation methods for the shear forces applied to each story are given in Figure 6.2.3.9-2. The shear forces are applied to the RCCV, RPV pedestal, external wall, and inner seismic wall. Inner walls where seismic loads are applied are shown in Figures 6.2.3.9-3 through 6.2.3.9-5 at each story.

Shear forces are distributed to walls in a story according to the method shown in Figure 6.2.3.9-6. Tables 6.2.3.9-2 and 6.2.3.9-3 summarize the shear areas of seismic walls. Tables 6.2.3.9-4 and 6.2.3.9-5 show the shear forces applied to each wall, which are calculated according to the method shown in Figure 6.2.3.9-6.

Shear forces are applied as horizontal nodal forces to grid points as illustrated in Figure 6.2.3.9-6. Their locations are described below.

- RCCV and seismic walls: Nodal forces are applied to grid points on floor slab levels.



- RCCV internal structures: refer to T12-5010 “Structural Design Report for Containment Internal Structures”, Reference 2.1.2-1.

In addition to shear forces applied to seismic walls, shear forces generated in the basemat in the SSI analyses are applied to the basemat nodes as nodal horizontal forces. The forces are distributed to all basemat nodes in proportion to the tributary weights of nodes. Applied shear forces are included in Tables 6.2.3.9-4 and 6.2.3.9-5.

Overturning Moments

The overturning moment applied to each story is determined in such a way that the sum of the applied moment and the one due to shear forces applied to the stories above is equal to or larger than the design moment of the story. The moment is adjusted considering the difference between the height where the design seismic loads are defined and the height where the seismic forces are applied. The calculation method is explained in Figure 6.2.3.9-2. Tables 6.2.3.9-6 through 6.2.3.9-11 summarize the overturning moments applied to the RB seismic walls, RCCV, and RPV pedestal, respectively. Columns “m+dMq” in these tables show the values of the applied moments.

Overturning moments are applied as vertical nodal forces to grid points as illustrated in Figure 6.2.3.9-7. The locations of the nodal forces are described below and shown in Figures 6.2.3.9-8 through 6.2.3.9-17.

- RB and FB: Nodal forces are applied to grid points that are on the external walls at floor slab levels.
- RCCV: Nodal forces are applied to grid points at the floor slab levels. At the top of the RCCV, EL 27,000, the design moment needs to be applied along the perimeter of the RCCV. In order to achieve this, a negative moment, which cancels the reactions on the top slab, is applied at the bottom of the pool girder. Then a moment with the same magnitude is applied to grid points on the top of the RCCV. This procedure is illustrated in Figure 6.2.3.9-18.
- Pool girder: Nodal forces are applied to the grid points that are on EL 34,000 and above the RCCV.

In addition to the design overturning moments mentioned above, an additional moment is applied to the basemat in order to adjust the total overturning moment imposed on the soil by the total shear force. The basemat is modeled at the center of its thickness, and the soil spring elements are directly attached to the basemat grid points. However, because the actual ground is underneath the basemat, an overturning moment, ΔM , which is calculated by the following equation, needs to be added. Tables 6.2.3.9-6 and 6.2.3.9-7 include the calculated additional overturning moments to be applied to the basemat.

$$\Delta M = Q \times t/2$$

where,

Q : total shear force at the bottom of the basemat

t : thickness of the basemat (= 4.0m)



The additional overturning moment is applied as vertical nodal forces to the basemat grid points. The magnitude of the vertical force per unit area is assumed to be proportional to the distance from the center of the basemat. The nodal force applied to each node is then calculated by multiplying it by the tributary area of the node.

Vertical Seismic Force

The vertical accelerations are determined from the design vertical accelerations shown in Tables 5.3.3-6 through 5.3.3-10.

The maximum vertical accelerations obtained from dynamic analyses are applied to the RB/FB walls, RCCV, RPV Pedestal and basemat. On the other hand, design vertical accelerations applied to slabs are determined using the following procedure.

- Slabs on each floor level are modeled with several masses in the dynamic analysis model as shown in Figure 5.3.3-1. The equivalent vertical slab acceleration is calculated using the following equation for each floor.

$${}_S A_{eq} = \frac{\sum {}_S A_i \cdot {}_S W_i}{\sum {}_S W_i}$$

where,

${}_S A_{eq}$: Equivalent slab acceleration

${}_S A_i$: Maximum acceleration of the i-th mass in the dynamic analysis results

${}_S W_i$: Weight of the i-th mass in the dynamic analysis model

- The total weights of the slabs are not included in the slab masses in the dynamic analysis model. Some of the weight is included in the RB/FB mass or RCCV mass. Therefore, the average slab accelerations are calculated using the following equation.

$${}_S A_{ave} = \frac{({}_S A_{eq} \cdot {}_S W_S + {}_{RB} A \cdot {}_{RB} W_S + {}_{CV} A \cdot {}_{CV} W_S)}{({}_S W_S + {}_{RB} W_S + {}_{CV} W_S)}$$

where,

${}_{RB} A, {}_{CV} A$: Maximum accelerations of the RB/FB and RCCV masses, respectively

${}_S W_S$: Summation of slab mass weights ($= \sum {}_S W_i$)

${}_{RB} W_S, {}_{CV} W_S$: Slab weights included in the RB/FB and RCCV masses, respectively

- The average accelerations, ${}_S A_{ave}$, shown in Table 6.2.3.9-12 is regarded as the design loads for the slabs. The accelerations are uniformly applied to all slab grid points.

Table 6.2.3.9-12 summarizes the design vertical accelerations.

For the RB/FB walls, RCCV, and RPV Pedestal, a design acceleration obtained at a given



elevation is applied to a region that is limited by the centerlines of that elevation and the upper and lower elevations.

The vertical seismic forces are applied to all grid points as upward vertical nodal forces. Each nodal force is calculated by multiplying the tributary weight of the node by the vertical acceleration determined for the region containing the node. The tributary weight of the node is obtained using the load combination for the vertical seismic loads, which consists of the dead load and a quarter of the floor live load. (Refer to Subsection 5.1.2.)

Torsional Moments

The calculation method of input torsional moments is given in Figure 6.2.3.9-19. The total torsional moment is calculated by summing up those for the RBFB wall, the RCCV wall and RPV pedestal. The torsional moment applied to each story is calculated by subtracting the total torsional moment for the story above from the total torsional moment for that story. The torsional moment applied to each story is determined in such a way that the sum of the applied moment and the one due to shear forces applied to the stories above is equal to or larger than the total torsional moment of the story.

The calculated torsional moments are applied to the seismic walls as in-plane shear forces. The calculation method of the shear forces due to torsional moment is described in Figure 6.2.3.9-20 and the results are summarized in Table 6.2.3.9-13. Torsional moments in the counterclockwise direction are considered to be positive.

The shear forces due to the torsional moments are applied as horizontal nodal forces to the grid points on floor slab levels. Their magnitudes are determined according to the tributary lengths of the nodes.

Out-of-plane Force of Walls

Out-of-plane forces are considered to walls whose out-of-plane natural frequency is less than 50 Hz. The out-of-plane forces of walls are determined from average out-of-plane wall accelerations calculated using design horizontal accelerations shown in SER-DMN-019 "RB/FB Seismic Analyses Bounding Results and In-Structure Response Spectra", Reference 2.1.2-k and the horizontal acceleration of wall's oscillators shown in Table 5.3.3-19.

The average out-of-plane wall accelerations are determined using the following procedure.

- Walls are modeled with several oscillators in the dynamic analysis model as shown in Figure 5.3.3-1 to evaluate the characteristics of out-of-plane responses of walls. An equivalent out-of-plane acceleration of all oscillators is calculated using the following equation for each wall.

$${}_w A_{eq} = \frac{\sum {}_w A_i \cdot {}_w W_i}{\sum {}_w W_i}$$

where,

${}_w A_{eq}$: Equivalent acceleration of all oscillators



${}_w A_i$: Maximum acceleration of the i-th oscillator in the dynamic analysis results

${}_w W_i$: Weight of the i-th oscillator in the dynamic analysis model

- A total weight of the wall is not included in its all oscillator in the dynamic analysis model. Some of the weight is included in the RB/FB mass. Therefore, the average out-of-plane wall accelerations are calculated using the following equation.

$${}_w A_{ave} = \frac{({}_w A_{eq} \cdot {}_S W_W + {}_{RB} A \cdot {}_{RB} W_W)}{({}_S W_W + {}_{RB} W_W)}$$

where,

${}_{RB} A$: Average maximum acceleration of top and bottom of the wall in the RB/FB stick

${}_S W_W$: Summation of wall oscillators weights ($= \sum {}_w W_i$)

${}_{RB} W_W$: Wall weights included in the RB/FB (except the ${}_S W_W$)

- The average accelerations, ${}_w A_{ave}$, shown in Table 6.2.3.9-15, are regarded as the design loads for the walls. The accelerations are uniformly applied to all wall grid points.

The out-of-plane seismic forces for walls are applied to all grid points of a wall as horizontal nodal forces. Each nodal force is calculated by multiplying the tributary weight of the node by the out-of-plane acceleration determined for the region containing the node. The tributary weight of the node is obtained using the load combination for the vertical seismic loads, which consists of the dead load and a quarter of the floor live load. (Refer to Subsection 5.1.2.)

6.2.3.9.2 Soil Pressure due to an Earthquake

Loads for two kinds of motion, N-S motion and E-W motion, are considered.

The soil pressure loads are applied to the external walls below grade. The method of applying the pressure is same as the method for the static soil pressure, which is described in Figures 6.2.3.9-21 through 6.2.3.9-26.

6.2.3.9.3 Sloshing Loads in Pools

Sloshing loads due to an earthquake are applied to the pool walls and slabs. Three directions of loads are considered corresponding to three directions of seismic loads, i.e., two horizontal and one vertical.

The details of the calculation of these sloshing loads are shown in Appendix A of Reference 2.1.2-k.

The loads are applied to shell elements as uniform pressure loads which are calculated at the centers of gravity of the elements. In the analysis for each direction, the loads in all pools are



applied simultaneously.

6.2.3.9.4 RPV Reactions due to Earthquake

RPV reactions due to an earthquake are applied only to the RCCV internal structures. For details of the load application methods, refer to T12-5010 "Structural Design Report for Containment Internal Structures", Reference 2.1.2-1.

6.2.3.9.5 Load Combinations for Seismic Loads

Analysis results for seismic loads mentioned above are combined in accordance with the load combinations shown in Table 6.2.3-9-14.

6.2.4 Analysis Results

Figures 6.2.4-1 through 6.2.4-23 indicate deformations of structures obtained by NASTRAN analyses for several design loads.

Tables 6.2.4-1 through 6.2.4-13 show the element forces and moments of the selected elements. The force and moment results for non-seismic load cases are obtained from Reference 2.1.2-e, while the seismic results are obtained from Reference 2.1.2-k. The locations of the selected elements are illustrated in Figures 6.2.4-24 through 6.2.4-34. The elements for tabulation are selected, in principle, from the center and both ends of wall and slab, where it is reasonably expected that the critical stresses appear based on engineering experience and judgment. Element forces and moments listed in the tables are defined with relation to the element coordinate system shown in Figure 6.2.4-35.

6.3 Load Combinations

6.3.1 Code Requirements

Reinforced concrete structures

The load combinations and associated load factors and acceptance criteria for reinforced concrete structures outside the containment are summarized in Table 6.3.1-1, which is in compliance with ACI 349-01 and SRP 3.8.4.

For the design of any structures which are integrated with the RCCV structures, the load combinations and associated load factors and acceptance criteria for the RCCV design are also considered. Therefore, Table 6.3.1-2, which is the load combination table for the RCCV design, is considered for the RB structures in addition to Table 6.3.1-1. Table 6.3.1-2 complies with ASME BPVC Sec III 2004.

Steel structures

The load combinations and associated load factors and acceptance criteria for steel structures outside the containment are summarized in Table 6.3.1-3, which is in compliance with ANSI/AISC N690-1994 Code and SRP 3.8.4.



6.3.2 Selection of Design Load Combinations

Reinforced concrete structures

The following load combinations given in Tables 6.3.1-1 and 6.3.1-2 need not be considered, because of the reasons described for each of the load combinations.

No.	Reason
RB-C5	Stresses in the basemat and pool due to wind loads W are negligibly small, and the combination RB-C3 covers these combinations.
RB-C6 RB-C8	These combinations are almost identical to CV-5, CV-7, respectively.
RB-C9	This combination is almost identical to CV-11.
CV-2	Stresses in the basemat and pool due to wind loads W are negligibly small, and the combination CV-3 covers CV-2.
CV-4, 6	Stresses in the basemat and pool due to wind loads W or tornado loads Wt are negligibly small, and these combinations are not critical for their design.
CV-5	This combination is covered by CV-11.
CV-8, 9	These combinations are covered by CV-7.
CV-10	Stresses in the basemat and pool due to wind loads W are negligibly small, and the combination CV-7 covers CV-10.

Finally, the following load combinations are selected for reinforced concrete structures.

- RB-C1, RB-C2, RB-C3, RB-C4, RB-C7, CV-1, CV-3, CV-7, CV-11

Detailed design load combinations are determined in terms of load patterns for the selected load combinations. Load patterns include time of year for thermal loads, time after an accident for LOCA pressure/thermal loads, and load application patterns for hydrodynamic loads. The determined detail design combinations for the RB concrete structures are shown in Table 6.3.2-1. The acceptance criteria for the selected combinations are also included in the tables. In addition, the load combinations selected as critical combinations in Appendix 3G of the ESBWR Design Control Document (DCD) are identified in the tables.

Steel structures

Among the load combinations listed in Table 6.3.1-3, the following combinations are negligible.

No.	Reason
RB-S1	This combination is covered by RB-S3.
RB-S2	This combination is covered by RB-S4.

The detail design combinations for the steel structures are shown in Table 6.3.2-2 together



with acceptance criteria.

Some remarks concerning the determination of the detailed load combinations are mentioned below.

- Two kinds of thermal loads, summer and winter, are considered. Because of the uncertainties in the thermal loads, two combinations which are almost same but different in including the thermal load or not are always considered in the detailed load combinations.
- Seismic loads include the following.
 - Sloshing load of the spent fuel pool water
 - RPV Reaction force due to earthquake
 - Dynamic increment of soil pressure
- Dynamic loads, i.e. seismic loads and hydrodynamic loads are combined according to the SRSS method, as specified in Section 6.3.2 of Reference 2.1.2-m.
- As for hydrodynamic loads, SRV, CO and CH, two patterns of loadings, i.e. full positive and negative, are considered in the design.
- The following loads are considered as LOCA hydrodynamic loads depending on the elapsed time after the LOCA.

Time after LOCA	Load to be considered
5 seconds	Pool Swell + SRV
6 minutes	CO + SRV
10 hours	CH + SRV
72 hours	CH + SRV

- For the tornado loads, the following combinations are considered in accordance with SRP 3.3.2.

$$W_t = W_w$$

$$W_t = W_p$$

$$W_t = W_w + 0.5W_p$$

where,

W_w : Tornado wind load

W_p : Tornado differential pressure load



6.3.3 Result of Load Combination

Tables 6.3.3-1 through 6.3.3-5 show the resultant combined forces and moments for the selected elements shown in Figures 6.2.4-24 through 6.2.4-34, which are calculated for several typical design load combinations selected from the load combinations listed in Table 6.3.2-1.

Section forces due to the following loads are shown independently in the tables.

- OTHR: Loads other than thermal and seismic loads
- TEMP: Thermal loads
- SEIS: Seismic loads
- HYDR: Hydrodynamic loads

Element forces and moments listed in the tables are defined with relation to the element coordinate system shown in Figure 6.2.4-35.

6.4 Section Design Principles

6.4.1 Section Design of Reinforced Concrete Structures

The design/evaluation is essentially performed using ASME, Section III, Division 2. The details of the design/evaluations and the exceptions to the use of ASME, Section III, Division 2 are described in the following Sections. The design flow chart is shown in Figure 6.4.1-1.

Section design calculations are carried out for the following section forces and it is confirmed that the results satisfy code requirements.

- Flexure and Membrane Forces
- Membrane Compressive Forces
- Transverse Shear

The evaluation method for each of the section forces is described in the following subsections.

6.4.1.1 Section Design for Flexure and Membrane Forces

Stress conditions of the RB structure sections are actually very complicated since the various forces, such as axial forces, in-plane shear, bending moments, and torsional moments, are applied simultaneously. It is difficult to estimate the section strength of the section under such a complicated stress condition by the equations which are normally used in the design calculation.

Therefore, stress calculations for flexure and membrane forces are performed by a computer program SSDP-2D. The program has the following characteristics.



- It calculates concrete and rebar stresses under two dimensional equilibrium conditions for six components of the section forces in a shell element – two axial forces, two bending moments, in-plane shear, and torsional moment.
- It takes concrete cracks into account in the stress calculation. Cracked concrete is assumed not to bear tensile forces.
- It assumes concrete and rebars to be perfectly elastic.
- It considers the reduction of thermal stresses due to the decreased stiffness of a cracked concrete section.
- Transverse shear is generated in an element but is not considered in the equilibrium conditions. Stresses of shear ties are not calculated with SSDP-2D. The design method for transverse shear is described in Section 6.4.1.3.

In calculations with SSDP-2D, section forces including in-plane shear force, axial forces and bending moments are considered simultaneously. In SSDP-2D, the compressive stress distribution of concrete is based on the linear distribution which is proportional to the strain distribution at the section. Moment capacity based on this condition is more conservative than the moment capacity specified in ACI 349-01 which is based on the stress block for the compressive stress distribution of concrete. Therefore, the wall design with SSDP-2D is considered to be more conservative than the design specified in ACI 349-01. This is further demonstrated in Appendices B and C for separate ACI 349-01 check for in-plane shear and axial compression, respectively.

As for the thermal effects, section forces due to thermal loads, which are evaluated by NASTRAN analyses using uncracked concrete stiffness, are reduced considering the depth and direction of cracking in calculations with SSDP-2D. The cracked section properties are used in the calculation only for the cracked sections. Furthermore, compatibility between strain distribution in a section and internal forces including reduced thermal stress is examined under an assumed crack condition in calculations with SSDP-2D. The calculations are continued until the compatibility of strain and internal forces are satisfied. During the iterative calculations, redistribution of internal forces and strains are considered adequately.

Table 6.4.1-1 shows the material constants used for the stress calculation. Allowable stresses specified in CC-3420 of ASME-2004 are used in the design, since they are not defined in ACI 349-01. Tables 6.4.1-2 and 6.4.1-3 show the allowable stresses of concrete and rebar.

As specified in Section 6.1 of U71-4010 “Design Specification for Reactor Building”, Reference 2.1.1-c, strengths of concrete and rebars are reduced taking effects of elevated temperatures into consideration, which is based on averaged temperature, T_d , obtained from the heat transfer analysis.

Reduction of concrete strength due to high temperature is determined based upon the average value of the following upper bound and lower bound equations.

- Lower bound reduction factor

$$\phi = 1.0 - 0.0030 (T - 21.1)$$

$$21.1^\circ\text{C} (70^\circ\text{F}) \leq T \leq 121.1^\circ\text{C} (250^\circ\text{F})$$



- $\phi = 0.70 - 0.00083 (T-121.1)$ $121.1^{\circ}\text{C} (250^{\circ}\text{F}) \leq T$
- Upper bound reduction factor
 - $\phi = 1.0$ $T \leq 260.0^{\circ}\text{C} (500^{\circ}\text{F})$
 - $\phi = 1.0 - 0.00081 (T-260.0)$ $260.0^{\circ}\text{C} (500^{\circ}\text{F}) \leq T$

Reduction of reinforcing steel strength is based upon the following equation.

- Reduction Factor
 - $\phi = 1.0 - 0.000873 (T-21.1)$ $21.1^{\circ}\text{C} (70^{\circ}\text{F}) \leq T \leq 204.4^{\circ}\text{C} (400^{\circ}\text{F})$

Allowable stresses listed in Tables 6.4.1-2 and 6.4.1-3 are reduced using these factors in calculations for load combinations including thermal loads.

6.4.1.2 Section Design for Membrane Compressive Forces

ASME-2004 specifies the allowable concrete stresses for membrane forces. It is necessary to confirm that the compressive stresses of the concrete due to membrane forces do not exceed the allowable stresses specified in CC-3420 of ASME-2004. Examinations for membrane compressive forces are also performed in the RB design in addition to examinations for flexure and membrane forces.

The principal membrane compressive stress σ_c , which is calculated by the following equation, is used for the evaluation.

$$\sigma_c = \frac{\sigma_x + \sigma_y}{2} - \sqrt{\left(\frac{\sigma_x - \sigma_y}{2}\right)^2 + \tau_{xy}^2} \quad (- \text{ for compression, } + \text{ for tension})$$

$$\sigma_x = \frac{N_x}{h}$$

$$\sigma_y = \frac{N_y}{h}$$

$$\tau_{xy} = \frac{N_{xy}}{h}$$

- where
- N_x : x-direction axial force per unit length (Tension is positive.)
 - N_y : y-direction axial force per unit length (Tension is positive.)
 - N_{xy} : in-plane shear force per unit length
 - h : element thickness

Table 6.4.1-4 shows the allowable membrane compressive stress of concrete. Reductions due to elevated temperatures described in Subsection 6.4.1.1 are applicable to these allowables.

Confirmation that compressive stresses of the concrete due to membrane forces do not



exceed the allowable stresses specified in Section 10.3.5 of ACI 349-01 is provided in Appendix C.

6.4.1.3 Section Design for Transverse Shear

Section design calculations for transverse shear are performed according to ACI 349-01, Chapter 11. It requires that the shear force at a section and section strength satisfy the following equation.

$$V_u \leq \phi(V_c + V_s)$$

where V_u : factored shear force at section per unit length

V_c : nominal shear strength provided by concrete per unit length

V_s : nominal shear strength provided by shear reinforcement per unit length

ϕ : strength reduction factor (=0.85)

The nominal shear strength provided by concrete, V_c , is calculated in accordance with Section 11.3.2 of ACI 349-01. The calculation method is shown in Figure 6.4.1-2. The nominal shear strength provided by shear reinforcement, V_s , is calculated by the following equation.

$$V_s = \rho_v f_y d, \quad V_s \leq 8\sqrt{f'_c} d \text{ (in English units)}$$

where ρ_v : shear reinforcement ratio

f_y : specified yield strength of rebar

d : distance from extreme compression fiber to centroid of tension reinforcement

f'_c : specified compressive strength of concrete

The transverse shear stress is evaluated in the direction of the maximum shear force, and the section forces for evaluation are calculated by the following equations.

$$V_u = \sqrt{Q_x^2 + Q_y^2}$$

$$M_u = M_x \sin^2 \theta + M_y \cos^2 \theta + 2M_{xy} \sin \theta \cos \theta$$

$$N_u = N_x \sin^2 \theta + N_y \cos^2 \theta + 2N_{xy} \sin \theta \cos \theta$$

$$\theta = \tan^{-1}(Q_x / Q_y)$$

In NASTRAN analyses, the transverse shear forces, i.e., Q_x and Q_y , are calculated independently in X and Y directions, respectively. The resultant transverse shear forces, i.e. the maximum transverse shear force (V_u), is calculated with SRSS method in order to consider transverse shear forces in two directions simultaneously. The value, θ means the



direction of the maximum shear force. The values N_u and M_u are also evaluated in the direction of the maximum shear force.

6.4.2 Section Design of Steel Structures

Section design of steel member is performed according to ANSI/AISC N690-94. Steel members, i.e., roof trusses and supporting columns, are examined by the evaluation method described in the following subsections.

The design flow of steel structures is almost same as the flow of reinforced concrete structures which is shown in Figure 6.4.1-1. However, reductions of thermal stresses are not considered for the steel design.

6.4.2.1 Section Design for Axial Compression and Bending

Steel members subjected to both axial compression and bending stresses shall be proportioned to satisfy the following requirements:

$$\frac{f_a}{F_a} + \frac{C_{mx} f_{bx}}{\left(1 - \frac{f_a}{F'_{ex}}\right) F_{bx}} + \frac{C_{my} f_{by}}{\left(1 - \frac{f_a}{F'_{ey}}\right) F_{by}} \leq 1.0 \quad (6.4.2-1)$$

$$\frac{f_a}{0.60F_y} + \frac{f_{bx}}{F_{bx}} + \frac{f_{by}}{F_{by}} \leq 1.0 \quad (6.4.2-2)$$

When $f_a/F_a \leq 0.15$, Equation (6.4.2-3) is permitted in lieu of Equations (6.4.2-1) and (6.4.2-2):

$$\frac{f_a}{F_a} + \frac{f_{bx}}{F_{bx}} + \frac{f_{by}}{F_{by}} \leq 1.0 \quad (6.4.2-3)$$

In Equations (6.4.2-1), (6.4.2-2) and (6.4.2-3), the subscripts x and y , combined with subscripts b , m and e , indicate the axis of bending about which a particular stress or design property applies, and

F_a = Axial compressive stress that would be permitted if axial force alone existed, ksi

F_b = Compressive bending stress that would be permitted if bending moment alone existed, ksi

$$F'_e = \frac{12\pi^2 E}{23(Kl_b/r_b)^2}$$

= Euler stress divided by a factor of safety, ksi (In the expression for F'_e , l_b is the actual unbraced length in the plane of bending and r_b is the corresponding radius of gyration. K is the effective length factor in the plane of bending.)



f_a = Computed axial stress, ksi

f_b = Computed compressive bending stress at the point under consideration, ksi

C_m = Coefficient whose value shall be taken as follows:

- a. For compression members in frames subject to joint translation (sidesway),
 $C_m = 0.85$.
- b. For rotationally restrained compression members in frames braced against joint translation and not subject to transverse loading between their supports in the plane of bending,

$$C_m = 0.6 - 0.4 (M_1/M_2).$$

where M_1/M_2 is the ratio of the smaller to larger moments at the ends of that portion of the member unbraced in the plane of bending under consideration. M_1/M_2 is positive when the member is bent in reverse curvature, negative when bent in single curvature.

- c. For compression members in frames braced against joint translation in the plane of loading and subjected to transverse loading between their supports, the value of C_m may be determined by an analysis. However, in lieu of such analysis, the following values are permitted:
 - i. For members whose ends are restrained against rotation in the plane of bending $C_m = 0.85$
 - ii. For members whose ends are unrestrained against rotation in the plane of bending $C_m = 1.0$

6.4.2.2 Section Design for Axial Tension and Bending

Steel members subjected to both axial tension and bending stresses shall be proportioned at all points along their length to satisfy the following requirement:

$$\frac{f_a}{F_t} + \frac{f_{bx}}{F_{bx}} + \frac{f_{by}}{F_{by}} \leq 1.0 \tag{6.4.2-4}$$

where f_b is the computed bending tensile stress, f_a is the computed axial tensile stress, F_b is the allowable bending stress and F_t is the governing allowable tensile stress.

6.4.2.3 Section Design for Transverse Shear

Steel members subjected to transverse shear stress shall be proportioned to satisfy the



following requirement:

$$\frac{f_v}{F_v} \leq 1.0 \quad (6.4.2-5)$$

where f_v is the computed shear stress and F_v is the governing allowable shear stress.

6.4.2.4 Allowable Stresses

6.4.2.4.1 Allowable Axial Tensile Stress

On the gross section of axially loaded tension members, the allowable stress is:

$$F_t = 0.60F_y \quad (6.4.2-6)$$

where F_y is the specified minimum yield stress of the type of steel being used, ksi.

6.4.2.4.2 Allowable Axial Compressive Stress

On the gross section of axially loaded compression members, when Kl/r , the largest effective slenderness ratio of any unbraced segment is less than C_c , the allowable stress is:

$$F_a = \frac{\left[1 - \frac{(Kl/r)^2}{2C_c^2} \right] F_y}{\frac{5}{3} + \frac{3(Kl/r)}{8C_c} - \frac{(Kl/r)^3}{8C_c^3}} \quad (6.4.2-7)$$

where

$$C_c = \sqrt{\frac{2\pi^2 E}{F_y}}$$

E = Modulus of elasticity of steel, ksi

On the gross section of axially loaded compression members, when Kl/r exceeds C_c , the allowable stress is:

$$F_a = \frac{12\pi^2 E}{23(Kl/r)^2} \quad (6.4.2-8)$$

6.4.2.4.3 Allowable Bending Stress of W-shaped Members (Strong Axis Bending)

The allowable stress for the strong axis bending of W-shaped members is given according to the procedure shown in Figure 6.4.2-1.

**6.4.2.4.4 Allowable Bending Stress of W-shaped Members (Weak Axis Bending)**

The allowable stress for the weak axis bending of W-shaped members is given according to the procedure shown in Figure 6.4.2-2.

6.4.2.4.5 Allowable Bending Stress of Box Members

The allowable bending stress of box members is given according to the procedure shown in Figure 6.4.2-3.

6.4.2.4.6 Allowable Shear Stress

For $h/t_w \leq 380/\sqrt{F_y}$, on the overall depth times the web thickness, the allowable shear stress is:

$$F_v = 0.40F_y \quad (6.4.2-9)$$

For $h/t_w > 380/\sqrt{F_y}$, the allowable shear stress on the clear distance between flanges times the web thickness is:

$$F_v = \frac{F_y}{2.89}(C_v) \leq 0.40F_y \quad (6.4.2-10)$$

where

$$C_v = \frac{45000k_v}{F_y(h/t_w)^2} \text{ when } C_v \text{ is less than } 0.8$$

$$= \frac{190}{h/t_w} \sqrt{\frac{k_v}{F_y}} \text{ when } C_v \text{ is more than } 0.8$$

$$k_v = 4.00 + \frac{5.34}{(a/h)^2} \text{ when } a/h \text{ is less than } 1.0$$

$$= 5.34 + \frac{4.00}{(a/h)^2} \text{ when } a/h \text{ is more than } 1.0$$

t_w = thickness of web, in.

a = clear distance between transverse stiffeners, in.

h = clear distance between flanges at the section under investigation, in.

7. SUMMARY OF RESULTS**7.1 Required Section**

Figures 7.1-1 through 7.1-4 shows typical sections of the RB concrete structures.



The sections of the steel members are shown in Figure 7.1-5.

7.2 Provided Section

The sections of the RB structures that have been provided are identical to the required sections described in Section 7.1.

7.3 Tabulation of Allowable Stresses versus Calculated Stresses

7.3.1 Reinforced Concrete Structure

7.3.1.1 Calculations for Flexure and Membrane Forces

The stresses of the concrete and reinforcing steel are calculated for flexure and membrane forces. The calculations are performed for the selected design load combinations shown in Table 6.3.2-1, and it is confirmed that all values are less than their allowable stresses.

The calculation results for the selected elements shown in Figures 6.2.4-24 through 6.2.4-34 are given in this report. The thicknesses and the rebar arrangements of selected element are shown in Table 7.3.1.1-1. The arrangement of shear tie at the exterior wall on column R7 at EL 22,500 to EL 24,600 is updated from standard design as shown in red in Table 7.3.1.1-1.

Calculated stresses and allowable stresses are compared in Tables 7.3.1.1-2 through 7.3.1.1-6 for several load combinations.

Table 7.3.1.1-7 gives a summary of the maximum stress ratios, which are ratios of the maximum stresses to the allowable stresses.

For RB shear walls, the maximum stress of the vertical rebar is found to be 319.7 MPa (46.36 ksi) at Section 23 due to the load combination RB-9b against the allowable stress of 372.2 MPa (53.97 ksi) as shown in Table 7.3.1.1-6. The maximum stress of the horizontal rebar is found to be 246.0 MPa (35.67 ksi) at Section 22 due to the load combination RB-9b against the allowable stress of 372.2 MPa (53.97 ksi) as shown in Table 7.3.1.1-6. The maximum concrete stress is found to be -17.9 MPa (-2.60 ksi), which occurs at Section 20 due to load combination RB-8b against the allowable stress of -29.3 MPa (-4.25 ksi), as shown in Table 7.3.1.1-4.

For RB foundation mat outside containment, Section 24 is selected for the foundation mat outside the containment at the junction with the cylindrical wall below the RCCV wall. The maximum stress of the top rebar is found to be 152.3 MPa (22.08 ksi) due to the load combination RB-9a against the allowable stress of 372.2 MPa (53.97 ksi) as shown in Table 7.3.1.1-5. The maximum stress of bottom rebar is found to be 59.4 MPa (8.61 ksi) due to the load combination RB-9a against the allowable stress of 372.2 MPa (53.97 ksi) also as shown in Table 7.3.1.1-5. The maximum concrete stress is found to be -5.2 MPa (-0.75 ksi), which occurs at Section 24 due to load combination RB-9b against the allowable stress of -23.5 MPa (-3.41 ksi), as shown in Table 7.3.1.1-6.

For floor slabs, Sections 25 to 27 are selected for the floor slabs at elevations EL 4,650, EL



17,500 and EL 27,000 at their junction with the RCCV. The maximum rebar stress of 273.0 MPa (39.59 ksi) due to the load combination RB-8b is found at Section 26 against the allowable stress of 372.2 MPa (53.97 ksi) as shown in Table 7.3.1.1-4. The maximum concrete stress is found to be -21.4 MPa (-3.10 ksi), which occurs at Section 25 due to load combination RB-9b against the allowable stress of -29.3 MPa (-4.25 ksi), as shown in Table 7.3.1.1-6.

For Pool Girders, Sections 28 to 30 are examined. The maximum rebar stress of 271.6 MPa (39.38 ksi) due to the load combination RB-9b is found in the horizontal rebar at Section 29 against the allowable stress of 358.3 MPa (51.95 ksi) as shown in Table 7.3.1.1-6, whereas the maximum vertical rebar stress is found to be 252.9 MPa (24.61 ksi) due to the load combination RB-9b at Section 28 against the allowable stress of 369.8 MPa (53.62 ksi) as shown in Table 7.3.1.1-6. The maximum concrete stress is found to be -13.7 MPa (-1.99 ksi), which occurs at Section 30 due to load combination RB-9b against the allowable stress of -27.4 MPa (-3.97 ksi), as shown in Table 7.3.1.1-6.

For MS tunnel, Section 31 is selected for the MS tunnel wall and slabs. The maximum rebar stress is found to be 230.6 MPa (33.44 ksi) due to the load combination RB-9b against the allowable stress of 372.2 MPa (53.97 ksi) as shown in Table 7.3.1.1-6. The maximum concrete stress is found to be -13.6 MPa (-1.97 ksi) due to load combination RB-4 against the allowable stress of -29.3 MPa (-4.25 ksi), as shown in Table 7.3.1.1-2.

For IC/PCCS Pool, Section 32 is selected for the pool wall in NS direction. The maximum stress of the vertical rebar is found to be 98.5 MPa (14.28 ksi) due to the load combination RB-9a against the allowable stress of 364.7 MPa (52.88 ksi) as shown in Table 7.3.1.1-5. The maximum stress of the horizontal rebar is found to be 82.6 MPa (11.98 ksi) due to the load combination RB-8b against the allowable stress of 343.4 MPa (49.79 ksi) as shown in Table 7.3.1.1-4. The maximum concrete stress is found to be -6.7 MPa (-0.97 ksi) due to load combination RB-9b against the allowable stress of -25.4 MPa (-3.68 ksi), as shown in Table 7.3.1.1-6.

7.3.1.2 Calculations for Membrane Compressive Forces

The compressive stress of concrete is calculated for membrane forces. The calculations are performed for the selected design load combinations shown in Table 6.3.2-1, and it is confirmed that the values are less than the allowable stress.

Table 7.3.1.2-1 gives a summary of the maximum compressive stresses for selected elements shown in Figures 6.2.4-24 through 6.2.4-34.

For RB shear walls, the maximum membrane compressive stress is found to be -9.942 MPa (-1.442 ksi) against the allowable stress of -25.9 MPa (-3.756 ksi) at Section 22, exterior wall at EL 4,650 to EL 6,600 as shown in Table 7.3.1.2-1.

For RB foundation mat outside containment, Section 24 is selected for the foundation mat outside the containment at the junction with the cylindrical wall below the RCCV wall. The maximum membrane compressive stress is found to be -1.855 MPa (-0.269 ksi) against the allowable stress of -16.6 MPa (-2.407 ksi) as shown in Table 7.3.1.2-1.



For floor slabs, Sections 25 to 27 are selected for the floor slabs at elevations EL 4,650, EL 17,500 and EL 27,000 at their junction with the RCCV. The maximum membrane compressive stress is found to be -14.169 MPa (-2.055 ksi) against the allowable stress of 25.9 MPa (-3.756 ksi) as shown in Table 7.3.1.2-1.

For Pool Girders, the maximum membrane compressive stress is found to be -9.962 MPa (-1.444 ksi) against the allowable stress of -25.9 MPa (-3.756 ksi) as shown in Table 7.3.1.2-1.

For MS tunnel, Section 31 is selected for the MS tunnel wall and slabs. The maximum membrane compressive stress is found to be -1.393 MPa (-0.202 ksi) against the allowable stress of -15.5 MPa (-2.248 ksi) as shown in Table 7.3.1.2-1.

For IC/PCCS Pool, Section 32 is selected for the pool wall in NS direction. The maximum membrane compressive stress is found to be -6.860 MPa (-0.995 ksi) against the allowable stress of -25.9 MPa (-3.756 ksi) as shown in Table 7.3.1.2-1.

7.3.1.3 Calculations for Transverse Shear

The transverse shear strength is calculated and compared with shear forces generated by design loads. The calculations are performed for the selected design load combinations shown in Table 6.3.2-1, and it is confirmed section forces are less than the shear strength of sections.

Table 7.3.1.3-1 gives a summary of the examinations for selected elements shown in Figures 6.2.4-24 through 6.2.4-34. Table 7.3.1.3-2 shows the calculation results for the load combinations selected for the DCD that are indicated in Table 6.3.1-1.

For RB shear walls, the maximum transverse shear force is found to be 4.95 MN/m (28.26 kips/in) against the shear strength of 6.61 MN/m (37.73 kips/in) at Section 20, the top of the cylindrical wall below the RCCV wall as shown in Table 7.3.1.3-2.

For RB foundation mat outside containment, Section 24 is selected for the foundation mat outside the containment at the junction with the cylindrical wall below the RCCV wall. The maximum transverse shear force is found to be 6.34 MN/m (36.19 kips/in) against the shear strength of 15.69 MN/m (89.57 kips/in) as shown in Table 7.3.1.3-2.

For floor slabs, Sections 25 to 27 are selected for the floor slabs at elevations EL 4,650, EL 17,500 and EL 27,000 at their junction with the RCCV. The maximum transverse shear force is found to be 8.30 MN/m (47.38 kips/in) against the shear strength of 10.65 MN/m (60.81 kips/in) as shown in Table 7.3.1.3-2.

For Pool Girders, the maximum transverse shear force is found to be 1.02 MN/m (5.82 kips/in) against the shear strength of 5.58 MN/m (31.85 kips/in) as shown in Table 7.3.1.3-2.

For MS tunnel, Section 31 is selected for the MS tunnel wall and slabs. The maximum transverse shear force is found to be 0.57 MN/m (3.26 kips/in) against the shear strength of 5.74 MN/m (32.78 kips/in) as shown in Table 7.3.1.3-2.

For IC/PCCS Pool, Section 32 is selected for the pool wall in NS direction. The maximum transverse shear force is found to be 0.23 MN/m (1.31 kips/in) against the shear strength of



2.42 MN/m (13.81 kips/in) as shown in Table 7.3.1.3-2.

7.3.2 *Steel Structure*

The stresses of the steel members are combined in accordance with Table 6.3.2-2, and it is confirmed that all values are less than the allowable stresses in accordance with the procedure in Subsection 6.4.2.

Table 7.3.2-1 lists the calculation results of the selected sections included in Figure 7.3.2-1. The stress ratios of the design stresses against their allowable stresses shown in the tables are the maximum ratios among all the load combinations.

7.4 **Missile Impact Evaluations**

Appendix A in Reference 2.1.2-e describes the design methodology and results of evaluation for exterior walls and roof slab of the Nuclear Island (NI) Seismic Category I (C-I) buildings against the tornado missile impact.

Appendix C in Reference 2.1.2-e describes the design methodology and evaluation for the effect of the impact of an automobile tornado missile on the Reactor Building (RB) structures including outer walls, roof slabs, trusses, and columns.

8. **CONCLUSIONS**

The site-specific stress check calculations for the RB structure are performed to evaluate the structural integrity of the RB at the NA3 site per the specifications of ACI 349-01, ASME-2004, and ANSI/AISC N690-1994, following the same methodology as that used for the standard design. The stress checks are based on the results of the global model analyses for the site-specific seismic loads combined together with the non-seismic load results from Reference 2.1.2-e according to site-specific seismic load combinations. The conclusions from the site-specific stress checks are summarized as follows:

- Reinforced concrete structures
 - The stresses of the concrete and rebar are less than the allowable stresses specified in the code.
 - The sections have enough strength to bear transverse shear forces generated by design loads.
- Steel structures
 - The stresses of steel members are less than the allowable stresses specified in the code.

Therefore, it can be concluded that the standard design of the RB structure is adequate to resist the NA3 site-specific SSE loads in combination with non-seismic standard plant loads.

The arrangement of shear ties at the exterior wall at EL 22,500 to EL 24,600 is updated from standard design to resolve the overstress for element 24211. These updates are shown in red



HITACHI

WG3-U71-ERD-S-0004	SH NO. 61
REV. 0	of 538

in Table 7.3.1.1-1.

The comparisons between NA3 and the standard design are shown in Appendix A.

In addition, the following structural evaluations are performed for the RB separately:

- The stability of the RB/FB at the NA3 site is demonstrated to resist the dynamic load demand without the shear keys that are part of the standard design of the RB/FB, as described in the "Reactor/Fuel Building Complex Stability Analysis Report," Reference 2.1.2-h.

**Table 3.1-1 Key Dimensions of RB and FB**

Building	Dimension		Notes
Reactor Building	Story	six stories (above grade) three stories (below grade)	Grade is 16.0 m from the top of basemat
	Plan	49.0 m × 49.0 m (below EL 34.0 m) 49.0 m × 39.0 m (above EL 34.0 m)	
	Height	64.2 m	From the top of the basemat
Fuel Building	Story	one story (above grade) three stories (below grade)	(excluding the penthouse) Grade is 16.0 m from the top of basemat
	Plan	21.0 m × 49.0 m	
	Height	34.0 m	From the top of the basemat (excluding the penthouse)
Common	Thickness of Basemat	4.0 m	The thickness is increased to 5.1m at the inside of RPV Pedestal and 5.5 m at the bottom of the Spent Fuel Pool.

**Table 3.1-2 Key Dimensions of RCCV**

Portion	Dimension	Notes
Foundation mat	Thickness = 5.1 m	
Containment wall	Thickness = 2.0 m	
	Inside radius = 18.0 m	
	Height = 19.95 m	From the top of the suppression pool slab to the bottom of the top slab
RPV pedestal	Thickness = 2.5 m	
	Inside radius = 5.6 m	
	Height = 15.05 m	From the top of the foundation mat to the top of the suppression pool slab
Top slab	Thickness = 2.4 m	
Suppression pool slab	Thickness = 2.0 m	



Table 5.1.1-1 Weights of Miscellaneous Steels and Finishing
(Reproduced from Reference 2.1.2-e)

Item		Weight	Note	
Roof Truss (EL 49700)		3.8 kN/m ²		
Metal Deck and Steel Beams	Roof Slabs	1.2 kN/m ²		
	Floor Slabs	3.0 kN/m ²	Except basemat	
Finishing	Slab	Roof Slabs	1.8 kN/m ²	
		Floor Slabs	1.0 kN/m ²	
	Outside Exterior Wall	Below Grade	0.2 kN/m ²	
		Above Grade	1.2 kN/m ²	
Various Pool Liner	Cavity Pool	Walls	1.0 kN/m ²	
		Slabs	0.7 kN/m ²	
	Dryer/Separator Pool	Walls	1.0 kN/m ²	
		Slabs	0.7 kN/m ²	
	Fuel Buffer Pool	Walls	1.0 kN/m ²	
		Slabs	1.6 kN/m ²	
	IC/PCCS Pool & Extension Pool	Walls	1.0 kN/m ²	
		Slabs	0.7 kN/m ²	
	Spent Fuel Pool	Walls	1.0 kN/m ²	
		Slabs	1.6 kN/m ²	
	Fuel Transfer Tube Pool	Walls	-	Not considered
		Slabs	-	Not considered
	Gate	Dryer/Separator Pool		- Not considered
		Reactor Well		- Not considered
Fuel Transfer Channel Pool		- Not considered		

Note: The values shown in this table are based on the following Design Specifications.

- 26A6605 Design Specification for Concrete Containment, Rev. 3
- 26A6606 Design Specification for Reactor Building, Rev. 2
- 26A6608 Design Specification for Fuel Building, Rev. 1



Table 5.1.1-2 Miscellaneous Structures, Piping, and Commodities Attached to the RCCV
(Reproduced from Reference 2.1.2-e)

Location	Area Load (kN/m²)	Concentrated Load (kN)
RCCV Top Slab Liner	2.5	
Upper Drywell Wall Liner	2.7	
Suppression Chamber Wall Liner	1.6	
Suppression Chamber Floor Liner	1.6	
Lower Drywell Wall Liner	3.1	
Lower Drywell Floor Liner	0.6	
Drywell Top Head		1100.0
Upper Drywell Personnel Airlock		200.0
Upper Drywell Equipment Hatch		110.0
Suppression Chamber Access Hatch		90.0
Lower Drywell Personnel Airlock		200.0
Lower Drywell Equipment Hatch		110.0

Note: The values shown in this table are based on the following Design Specifications.

- 26A6605 Design Specification for Concrete Containment, Rev. 3
- 26A6606 Design Specification for Reactor Building, Rev. 2
- 26A6608 Design Specification for Fuel Building, Rev. 1



Table 5.1.1-3 Miscellaneous Structures, Piping, and Commodities on the Slabs
 (Reproduced from Reference 2.1.2-e)

Elevation (m)	Piping Area Load (kN/m ²)		Note
	RB	FB	
52.40 ^{*1}	2.4		
34.00	2.4		
27.50	-	0.0	FB Roof Slab
27.00	2.4		
22.50	-	2.4	
17.50	9.8		Diaphragm Floor
	19.6		Main Steam Tunnel
	2.4		Other Area
13.57	2.4		
9.06	2.4		
4.65	2.4	2.4	
-1.00	2.4	2.4	
-6.40	2.4	2.4	
-11.50	2.4	2.4	

General Note: The values shown in this table are based on the following Design Specifications.

26A6605 Design Specification for Concrete Containment, Rev. 3

26A6606 Design Specification for Reactor Building, Rev. 2

26A6608 Design Specification for Fuel Building, Rev. 1

Note

*1: The difference between the modeled elevation 52.4 m and the actual elevation 52.7 m at the RB roof is negligibly small.



HITACHI

WG3-U71-ERD-S-0004 SH NO. 67
REV. 0 of 538

Table 5.1.1-4 Miscellaneous Structures, Piping, and Commodities on the RCCV Walls

(Reproduced from Reference 2.1.2-e)

Elevation (m)	Piping Area Load (kN/m²)	Portion
17.5~27.0	2.4	Upper Drywell
13.57~17.5	2.4	Upper Drywell
9.06~13.57	2.4	Wetwell
4.65~9.06	2.4	Wetwell
-1.00~4.65	2.4	Lower Drywell
-6.40~-1.00	2.4	Lower Drywell
-11.50~-6.4	2.4	Lower Drywell



**Table 5.1.1-5 Dead Loads of Equipment RB
(Reproduced from Reference 2.1.2-e)**

Elevation (m)	Item No.*	Description	Weight				Area Load (kN/m ²)
			unit (kN)	qt.	margin	Sum up (kN)	
-11.50	R-1	Sacrificial Concrete					36
	R-2	HCU Room A~D	643	4	0.2	3086	
	R-3	RWCU Non-Regen Heat Exchanger	113	3	0.2	406	
	R-4	RWCU Regen Heat Exchanger	44	2	0.2	106	
	R-5	RWCU Pump Room A, B	216	2	0.2	518	
	R-6	Process Sampling Monitoring room	95	1	0.2	114	
	R-7	RWCU Transfer Pumps Room	34	1	0.2	41	
-6.40	R-11	RWCU Filter Demineralizers Vault A1, A2, B1, B2	284	4	0.2	1365	
	R-12	Control Rod Drive Pump Room	236	1	0.2	284	
	R-13	Divisional Battery rooms	1079	4	0.2	5178	
-1.00	R-21	Divisional I~ IV Electrical equipment rooms	588	4	0.2	2824	
4.65	R-31	Quenchers	35	12	0.2	509	
	R-32	CRD A ~ D Panel Room	490	4	0.2	2354	
9.60	R-41	Electrical Equipment Rooms A~D	637	4	0.2	3060	
13.57	R-51	Wetwell Access/Fan Room	118	4	0.2	565	
27.00	R-71	Isolation Condensers Heat Exchanger Room A~D	333	4	0.2	1601	
	R-72	Passive Containment Cooling Heat Exchanger Room A~F	233	6	0.2	1681	
	R-73	Standby Liquid Control Tank Room A, B	530	2	0.2	1271	
	R-74	Standby Liquid Control Tank Pump A, B	20	3	0.2	71	
	R-75	Fuel Storage Racks					153
	R-76	Skimmer Tanks	382	2	0.2	918	
34.00	CR-4	Refueling Machine	343	1	0.2	412	
39.80	CR-5	Reactor Building Crane	1422	1	0.2	1706	
	CR-6	Lifted Loads	1750	1	-	1750	

General Note: The values shown in this table are based on the following Design Specifications.
 26A6605 Design Specification for Concrete Containment, Rev. 3
 26A6606 Design Specification for Reactor Building, Rev. 2
 26A6608 Design Specification for Fuel Building, Rev. 1

Note *: Refer to Figures 5.1.1-1 through 5.1.1-9.



Table 5.1.1-6 Dead Loads of Equipment FB
(Reproduced from Reference 2.1.2-e)

Elevation (m)	Item No.*	Description	Weight				Area Load (kN/m ²)
			unit (kN)	qt.	margin	Sum up (kN)	
-11.50	F-1	Skimmer Tank	353	1	0.2	424	
	F-2	Spent Fuel Racks	16239	1	0.2	19487	
	F-3	Spent Fuel Cask					120
	F-4	Fuel and Auxiliary Pools Cooling Backwash Tank Room	353	1	0.2	424	
	F-5	Fuel and Auxiliary Pools Cooling Heat Exchange Room	236	1	0.2	284	
	F-6	Sump Room	95	1	0.2	114	
	F-7	Fuel and Auxiliary Pools Cooling Transfer Pump Room	17	2	0.2	41	
	F-8	Fuel and Auxiliary Pools Cooling Pump Room	112	1	0.2	134	
-6.40	F-11	Fuel and Auxiliary Pools Cooling Filter/Demineralizer Vault	142	2	0.2	341	
	F-12	FAPC Holding Pump Room	37	1	0.2	45	
	F-13	Control Rod Drive Maintenance Area	49	1	0.2	59	
	F-14	Control Rod Drive Maintenance Control Panel Room	38	1	0.2	46	
	F-15	Control Rod Drive Motor Test Room	98	1	0.2	118	
-1.00	F-21	New Fuel Prep Machine Pit	12	1	0.2	15	
4.65	CR-1	Fuel Handling Machine	343	1	0.2	412	
13.57	CR-2	Fuel Building Crane	1079	1	0.2	1295	
	CR-3	Lifted Load	1750	1	-	1750	
22.50	F-61a	HVAC Penthouse	112	2	0.2	269	
	F-61b	HVAC Penthouse	112	2	0.2	269	
	F-61c	HVAC Penthouse	174	2	0.2	416	
	F-61d	HVAC Penthouse	322	2	0.2	772	
	F-61e	HVAC Penthouse	292	2	0.2	701	

General Note: The values shown in this table are based on the following Design Specifications.
 26A6605 Design Specification for Concrete Containment, Rev. 3
 26A6606 Design Specification for Reactor Building, Rev. 2
 26A6608 Design Specification for Fuel Building, Rev. 1

Note *: Refer to Figures 5.1.1-1 through 5.1.1-9.



Table 5.1.1-7 Dead Loads of Hydrostatic Loads
(Reproduced from Reference 2.1.2-e)

Location	Water Depth (m)	Pressure (kN/m ²)	Note
Cavity Pool	6.7	66.0	
	2.9	28.0	On the Drywell Top Head
Dryer / Separator Pool	6.7	66.0	
Fuel Buffer Pool	6.7	66.0	
IC / PCCS Pool	4.8	47.0	
IC / PCCS Expansion Pools	4.8	47.0	
GDCS Pools	6.8	67.0	
Lower Drywell	12.37	121.0	During LOCA Flooding
Suppression Pool	5.5	54.0	
	6.55	64.0	During LOCA Flooding
Spent Fuel Pool	14.35	141.0	



Table 5.1.2-1 Floor Live Loads
(Reproduced from Reference 2.1.2-e)

Elevation (m)	Area Load (kN/m ²)		Remarks
	RB	FB	
52.40 ^{*1}	2.9	-	Roof
34.00	4.8	-	Indoor Slab
	2.9	-	Roof Slab
27.50	-	2.9	FB roof slab of penthouse
27.00	4.8 ^{*2}	-	
	2.9	-	Main Steam Tunnel Roof
22.50	-	2.9	
17.50	4.8	-	
	0.0	-	Main Steam Tunnel Floor
13.57	4.8	-	
9.06	4.8	-	
4.65	4.8	4.8	
-1.00	4.8	4.8	
-6.40	4.8	4.8	
-11.50	4.8	4.8	

Note

*1: The difference between the modeled elevation 52.4 m and the actual elevation 52.7 m at the RB roof is negligibly small.

*2: Live load at pool water area is zero.



Table 5.1.2-2 Design Lateral Soil Pressure at-Rest
(Reproduced from Reference 2.1.2-e)

Elevation (m)	Soil Pressure (kN/m ²)			Note
	RB on R1 column-row Wall	FB on FA column-row Wall	Other Walls	
4.65	11.0	175.4	11.0	Grade
4.04	21.9	186.3	21.9	Water level
-1.00	127.7	292.1	127.7	
-4.20	194.9	359.3	194.9	Bottom level of TB basemat
-4.20	457.9			
-6.40	504.1	405.5	241.0	
-11.50	611.1	512.5	348.1	
-15.50	695.1	596.5	432.0	Bottom level of basemat



Table 5.2.1-1 Design Pressure Loads for Containment and IC/PCCS Pools
(Reproduced from Reference 2.1.2-e)

Event		Pressure (kPag)		
		Drywell	Wetwell	IC/PCCS Pool
Normal Operation		9.0	9.0	34.5
Test	maximum internal pressure	356.8	356.8	0.0
	maximum differential pressure	310.0	32.5	0.0
LOCA	5 seconds after DBA	(345.0)*	(250.0)*	48.3
	6 minutes after DBA	257.0	241.0	48.3
	10 hours after DBA	310.0	310.0	48.3
	72 hours after DBA	310.0	310.0	48.3

*: The pressure loads at 5 seconds are considered in the load of Pool Swell Pressure Loads.

Table 5.2.1-2 Design Times for LOCAs
(Reproduced from Reference 2.1.2-e)

Selected Time	Reasons for Selection
5 seconds	Just after LOCA Combination including Pool Swell
6 minutes (0.1 hr.)	Containment temperatures reach their maximum values. Combination including Condensation Oscillation
10 hours	Containment pressures reach their maximum values. Combination including Chugging
72 hours	Concrete temperatures reach their maximum values. Combination including Chugging



Table 5.2.2-1 Steady State Temperature Conditions
(Reproduced from Reference 2.1.2-e)

Region		Temperature (°C)		Note
		Summer	Winter	
	Main Steam Tunnel	57.0	57.0	
Inside Containment	Drywell	57.0	57.0	
	GDCS pool	43.0	43.0	
	Wetwell & Suppression pool	43.0	43.0	
RB Outside Containment	RB rooms outside containment	40.0	10.0	
	Reactor Cavity pool	43.0	43.0	
	Dryer/Separator Storage pool	43.0	43.0	
	Fuel Buffer pool	43.0	43.0	
	IC/PCCCS pool	43.0	43.0	
FB	FB rooms	40.0	10.0	
	Spent Fuel Pool	48.9	48.9	
	Exterior	46.1	-40.0	
	Ground	15.5	15.5	

Table 5.2.2-2 Design Basis Accident Temperatures in Spent Fuel Pool
(Reproduced from Reference 2.1.2-e)

Time		Temperature (°C)
(hr.)	(sec)	
0.00	0	48.9
0.06	200	49.2
0.28	1000	50.5
0.50	1800	51.8
1.00	3600	54.7
5.00	18000	77.7
8.86	31900	100.0
10.00	36000	100.0
20.00	72000	100.0
72.00	259200	100.0

Note: DBA for the spent fuel pool is due to loss of Fuel and Auxiliary Pools Cooling System (FAPCS) cooling function



HITACHI

WG3-U71-ERD-S-0004 SH NO. 75
REV. 0 of 538

Table 5.2.4-1 RPV Reactions
(Reproduced from Reference 2.1.2-e)

		SRV	LOCA
Vertical	(MN)	16.45	9.25
Shear	(MN)	11.63	2.878
Moment	(MNm)	75.3	28.7



Table 5.3.1-1 Design Wind Pressure Loads by Floor Level
(Reproduced from Reference 2.1.2-e)

Height (m)		Design Wind Load (kN/m ²)			
EL	Z	Windward Wall	Leeward Wall	Side Wall	Roof
52.40 ^{*1}	47.75	3.13	-2.20	-2.82	-3.87
34.00	29.35	2.93	-2.20	-2.82	-3.87
27.00	22.35	2.82	-2.20	-2.82	
17.50	12.85	2.62	-2.20	-2.82	
13.57	8.92	2.50	-2.20	-2.82	
9.22	4.57	2.30	-2.20	-2.82	
9.06	4.41	2.30	-2.20	-2.82	
4.65	0.00	2.30	-2.20	-2.82	

Importance factor I 1.15
 Basic wind speed V 62.59 m/s
 Wind directionality factor Kd 0.85

Coef.	Wall			Roof
	Windward	Leeward	Side	
G	0.85			
Cp	0.8	-0.5	-0.7	-1.04
GCpi	-0.18	0.18	0.18	0.18

Note

*1: The difference between the modeled elevation 52.4 m and the actual elevation 52.7 m at the RB roof is negligibly small.

Table 5.3.2-1 Design Pressure of Tornado Wind Load
(Reproduced from Reference 2.1.2-e)

Wind Direction	Building	p (kN/m ²)			
		Wall			Roof
		Windward	Leeward	Side	
All	RB/FB	5.6	-3.5	-4.9	-7.3
Differential		16.5	16.5	16.5	16.5



Table 5.3.3-1 Design Seismic Loads for Horizontal SSE (RB and FB Walls)

Elev. (m)	Elem No.	Node No.	Shear		Moment		Calculated Torsion (MN-m)	Accidental Torsion (MN-m)	Design Torsion (MN-m)
			X-Dir. (MN)	Y-Dir. (MN)	X-Dir. (MN-m)	Y-Dir. (MN-m)			
52.40*1	1110	110	192.2	140.0	2724 5838	2143 4488	1284	471	1755
34.00	1109	109	173.2	113.9	8196 8719	5821 6389	1938	424	2362
27.00	1108	108	396.0	259.4	9400 9599	7162 7958	2799	1321	4120
22.50	1107	107	436.4	291.8	11216 11424	8328 9227	4678	1486	6164
17.50	1106	106	438.4	343.5	12105 12349	9408 10195	4023	1535	5557
13.57	1105	105	450.7	363.7	12839 13651	10255 11216	4211	1578	5788
9.06	1104	104	454.6	383.4	13904 15231	11338 12506	4694	1591	6285
4.65	1103	103	454.7	360.1	9392 10952	6302 7759	5248	1591	6839
-1.00	1102	102	240.0	226.6	6545 7303	4819 5358	2718	840	3558
-6.40	1101	101			4748	3351			
-11.50		2	237.7	200.4	5053	3356	2079	832	2910

Note: RB/FB Seismic Analyses Bounding Results and In-Structure Response Spectra. (Table 4.1-1 of Reference 2.1.2-k)

The node numbers in this table are described in Figure 5.3.3-1.

*1: The difference between the modeled elevation 52.4 m and the actual elevation 52.7 m at the RB roof is negligibly small.



Table 5.3.3-2 Design Seismic Loads for Horizontal SSE (RCCV)

Elev. (m)	Elem No.	Node No.	Shear		Moment		Calculated Torsion (MN-m)	Accidental Torsion (MN-m)	Design Torsion (MN-m)
			X-Dir. (MN)	Y-Dir. (MN)	X-Dir. (MN-m)	Y-Dir. (MN-m)			
34.00	1209	209			230	510			
			130.9	133.2	1029	1160	29	266	296
27.00	1208	208			2162	2303			
			141.1	151.9	2938	3071	1489	304	1793
17.50	1206	206			3259	3667			
			184.1	158.4	3691	3904	1591	368	1960
13.57	1205	205			3817	4203			
			207.9	173.4	4389	4491	1762	416	2178
9.06	1204	204			4481	4853			
			225.4	201.2	5190	5203	2062	451	2513
4.65	1203	203			5523	5470			
			109.2	125.7	5740	5824	1439	251	1691
-1.00	1202	202			6008	6066			
			67.6	68.1	5924	6035	690	136	826
-6.40	1201	201			6053	6141			
-11.50		2	70.7	55.1	5961	6127	349	141	490

Note: RB/FB Seismic Analyses Bounding Results and In-Structure Response Spectra. (Table 4.1-2 of Reference 2.1.2-k)

The node numbers in this table are described in Figure 5.3.3-1.



Table 5.3.3-3 Design Seismic Loads for Horizontal SSE (RPV Pedestal and Vent Wall)

Elev. (m)	Elem No.	Node No.	Shear		Moment		Calculated Torsion (MN-m)	Accidental Torsion (MN-m)	Design Torsion (MN-m)
			X-dir. (MN)	Y-dir. (MN)	X-dir. (MN-m)	Y-dir. (MN-m)			
17.5	701	701	47.9	32.4	107 139	62 107	107	40	147
14.5	702	702	47.1	32.4	139 279	113 204	108	39	148
11.5	703	703	45.8	35.1	280 411	207 301	111	38	149
8.5	704	704	44.7	36.5	411 458	302 338	112	37	149
7.4625	705	705	39.1	29.4	440 513	352 427	92	33	125
4.65	1303	706,303	20.5	16.9	667 651	496 502	71	16	87
2.4165	1377	377	32.1	31.4	793 754	614 631	86	26	112
-1.00	1302	302	22.1	15.7	691 658	571 555	34	18	52
-2.75	1376	376	21.8	16.1	658 594	555 524	34	17	52
-6.40	1301	301	29.8	22.4	555	518	21	24	45
-11.50		2			553	514			

Note: RB/FB Seismic Analyses Bounding Results and In-Structure Response Spectra. (Tables 4.1-3 and 4.1-4 of Reference 2.1.2-k)

The node numbers in this table are described in Figure 5.3.3-1.



Table 5.3.3-4 Design Seismic Loads for Horizontal SSE (RSW)

Elev. (m)	Elem No.	Node No.	Shear		Moment		Calculated Torsion (MN-m)	Accidental Torsion (MN-m)	Design Torsion (MN-m)
			X-dir. (MN)	Y-dir. (MN)	X-dir. (MN·m)	Y-dir. (MN·m)			
24.18	707	707	4.19	2.95	18.9	13.8	0.5	2.0	2.5
20.2	708	708	20.83	11.08	113.5	59.3	1.7	9.8	11.6
15.775	709	709	24.35	12.29	224.1	115.5	2.4	11.5	13.9
11.35	710	710	27.11	13.51	331.9	169.3	3.0	12.8	15.8
7.4625	711	711	26.62	22.22	169.6	151.7	22.9	12.6	35.5
4.65	712	712	14.27	13.53	147.3	132.8	15.2	6.7	21.9
2.4165	713	713	1.55	1.55	3.3	3.3	0.2	0.7	0.9
1.96	714	714			3.0	3.0			
-0.8		715	0.92	0.92	0.7	0.6	0.1	0.4	0.5

Note: RB/FB Seismic Analyses Bounding Results and In-Structure Response Spectra. (Table 4.1-4 of Reference 2.1.2-k)

The node numbers in this table are described in Figure 5.3.3-1.



Table 5.3.3-5 Design Seismic Loads for Horizontal SSE (RPV)

Elev. (m)	Elem No.	Node No.	Axial (MN)	Shear		Moment	
				X-dir. (MN)	Y-dir. (MN)	X-dir. (MN-m)	Y-dir. (MN-m)
3.215	844	845	9.10	18.6	7.9	29.9	15.6
2.365		846				44.5	18.9
8.453	871	815	24.75	29.8	18.8	182.7	151.9
7.4625		711				176.6	147.4

Note: RB/FB Seismic Analyses Bounding Results and In-Structure Response Spectra. (Tables 4.1-5 and 4.1-6 of Reference 2.1.2-k)

The node numbers in this table are described in Figure 5.3.3-1.



Table 5.3.3-6 Maximum Vertical Accelerations (RB and FB)

Elev. (m)	Node No.	Stick Model	Max. Vertical Acceleration (g)
52.4*1	110	RFBF	1.56
34.00	109	RFBF	1.20
27.00	108	RFBF	1.02
22.50	107	RFBF	0.92
17.50	106	RFBF	0.80
13.57	105	RFBF	0.72
9.06	104	RFBF	0.62
4.65	103	RFBF	0.56
-1.00	102	RFBF	0.57
-6.40	101	RFBF	0.53
-11.50	2	RFBF	0.51
-15.50	1	RFBF	0.52

Note: RB/FB Seismic Analyses Bounding Results and In-Structure Response Spectra. (Table 4.2-1 of Reference 2.1.2-k)

The node numbers in this table are described in Figure 5.3.3-1.

*1: The difference between the modeled elevation 52.4 m and the actual elevation 52.7 m at the RB roof is negligibly small.

Table 5.3.3-7 Maximum Vertical Accelerations (RCCV)

Elev. (m)	Node No.	Stick Model	Max. Vertical Acceleration (g)
34.00	209	RCCV	1.20
27.00	208	RCCV	1.12
17.50	206	RCCV	0.91
13.57	205	RCCV	0.82
9.06	204	RCCV	0.72
4.65	203	RCCV	0.65
-1.00	202	RCCV	0.58
-6.40	201	RCCV	0.55

Note: RB/FB Seismic Analyses Bounding Results and In-Structure Response Spectra. (Table 4.2-2 of Reference 2.1.2-k)

The node numbers in this table are described in Figure 5.3.3-1.



Table 5.3.3-8 Maximum Vertical Accelerations (RPV Pedestal and Vent Wall)

Elev. (m)	Node No.	Stick Model	Max. Vertical Acceleration (g)
17.50	701	VW	0.82
14.50	702	VW	0.86
11.50	703	VW	0.81
8.50	704	VW	0.72
7.4625	705	VW	0.67
4.65	706, 303	Pedestal	0.69
-1.00	302	Pedestal	0.59
-6.40	301	Pedestal	0.56

Note: RB/FB Seismic Analyses Bounding Results and In-Structure Response Spectra. (Tables 4.2-3 and 4.2-4 of Reference 2.1.2-k)

The node numbers in this table are described in Figure 5.3.3-1.

Table 5.3.3-9 Maximum Vertical Accelerations (RSW)

Elev. (m)	Node No.	Stick Model	Z-dir. (g)
24.18	707	RSW	1.30
20.20	708	RSW	1.23
15.775	709	RSW	0.99
11.35	710	RSW	0.78
7.4625	711	RSW	0.68
4.65	712	RSW	0.69
2.4615	713	RSW	0.64
1.96	714	RSW	0.64
-0.80	715	RSW	0.64

Note: RB/FB Seismic Analyses Bounding Results and In-Structure Response Spectra. (Table 4.2-4 of Reference 2.1.2-k)

The node numbers in this table are described in Figure 5.3.3-1.



Table 5.3.3-10 Enveloping Maximum Vertical Acceleration: RBF B Flexible Slab Oscillators

Elev. (m)	Node No.	Stick Model	Max. Vertical Acceleration (g)
52.4*	9101	Oscillator	0.33
	9102	Oscillator	1.33
	9103	Oscillator	6.27
	9104	Oscillator	2.62
	9105	Oscillator	2.42
	9106	Oscillator	3.74
	9107	Oscillator	3.22
	9108	Oscillator	2.50
	9109	Oscillator	1.53
34.00	9091	Oscillator	1.61
	9092	Oscillator	1.61
	9093	Oscillator	1.12
27.00	9081	Oscillator	1.64
	9082	Oscillator	1.52
	9083	Oscillator	1.30
	9084	Oscillator	1.67
	9085	Oscillator	1.46
	9086	Oscillator	1.12
	9087	Oscillator	1.03
22.50	9071	Oscillator	1.15
	9072	Oscillator	1.79
	9073	Oscillator	4.47
	9074	Oscillator	1.67
	9075	Oscillator	1.51
	9076	Oscillator	1.65
17.50	9061	Oscillator	3.65
	9062	Oscillator	2.62
	9063	Oscillator	1.17
	9064	Oscillator	2.56
	9065	Oscillator	1.28
	99064	Oscillator	0.99
	9066	Oscillator	1.09
	9067	Oscillator	0.91

Note: Bounding Equivalent Out-of-plane Acceleration Loads on Slabs are shown in RB/FB Seismic Analyses Bounding Results and In-Structure Response Spectra. (Table 4.2-1 of Reference 2.1.2-k)

*: The difference between the modeled elevation 52.4 m and the actual elevation 52.7 m at the RB roof is negligibly small.



Table 5.3.3-10 Enveloping Maximum Vertical Acceleration: RBFB Flexible Slab Oscillators (Continued)

Elev. (m)	Node No.	Stick Model	Max. Vertical Acceleration (g)
13.57	9051	Oscillator	1.11
	9052	Oscillator	1.25
	9053	Oscillator	0.99
	9054	Oscillator	0.83
9.06	9041	Oscillator	1.02
	9042	Oscillator	1.26
	9043	Oscillator	0.93
	9044	Oscillator	0.80
4.65	9031	Oscillator	1.62
	9032	Oscillator	0.89
	9033	Oscillator	1.12
	9034	Oscillator	1.81
	9035	Oscillator	1.09
	9036	Oscillator	0.94
	9037	Oscillator	0.82
-1.00	9021	Oscillator	0.97
	9022	Oscillator	2.07
	9023	Oscillator	0.98
	9024	Oscillator	1.12
	9025	Oscillator	1.21
	9026	Oscillator	1.63
	9027	Oscillator	0.93
	9028	Oscillator	0.96
	9029	Oscillator	1.30
	9030	Oscillator	0.87
-6.40	9011	Oscillator	0.84
	9012	Oscillator	1.17
	9013	Oscillator	1.52
	9014	Oscillator	1.19
	9015	Oscillator	1.03

Note: Bounding Equivalent Out-of-plane Acceleration Loads on Slabs are shown in RB/FB Seismic Analyses Bounding Results and In-Structure Response Spectra. (Table 4.2-1 of Reference 2.1.2-k)



Table 5.3.3-11 Soil Pressure Due to an Earthquake

Elevation (m)	Soil Pressure (MPa)		Note
	R1 and F3 Wall	RA and RG Wall	
4.65			Grade
-1.00	0.56	0.45	
-6.40	0.28	0.29	
-11.50	0.24	0.22	
-15.50	0.94	0.76	



Table 5.3.3-12 Sloshing Loads for GDCS Pool

Longitudinal Direction Motion				Transversal Direction Motion				Vertical Motion		
Wall		Floor		Wall		Floor		Wall	Floor	
Depth d/H	Pressure (kN/m ²)	Distance x/(L/2)	Pressure (kN/m ²)	Depth d/H	Pressure (kN/m ²)	Distance x/(L/2)	Pressure (kN/m ²)	Depth d/H	Pressure (kN/m ²)	Pressure (kN/m ²)
0.0	9.7	0.0	0.0	0.0	9.8	0.0	0.0	0.0	0.0	68.0 for all floor area
0.2	21.0	0.2	6.1	0.2	15.6	0.2	4.3	0.2	13.6	
0.4	35.8	0.4	13.1	0.4	23.8	0.4	8.8	0.4	27.2	
0.6	46.6	0.6	22.2	0.6	26.1	0.6	13.7	0.6	40.8	
0.8	53.1	0.8	35.1	0.8	26.1	0.8	19.4	0.8	54.4	
1.0	55.3	1.0	55.3	1.0	26.1	1.0	26.1	1.0	68.0	

- Notes: 1) "d" is depth from the top of water. "H" is water height of the pool (6.8 m).
 2) "x" is distance from the center of the pool. "L" is width of the pool.
 3) Floor pressure due to vertical motion is for reference only. It is already included in vertical seismic loads for the floor.
 4) This load is applied on the RCCV wall. Sloshing loads on the GDCS internal structure wall are evaluated separately, taking into account flexibility of the wall.

Table 5.3.3-13 Sloshing Loads for RPV Cavity / Dryer Separator / Fuel Buffer Pool

NS / EW Motion				Vertical Motion		
Wall		Floor		Wall	Floor	
Depth d/H	Pressure (kN/m ²)	Distance x/(L/2)	Pressure (kN/m ²)	Depth d/H	Pressure (kN/m ²)	Pressure (kN/m ²)
0.0	15.2	0.0	0.0	0.0	0.0	76.2 for all floor area
0.2	23.1	0.2	8.0	0.2	15.2	
0.4	37.0	0.4	16.7	0.4	30.5	
0.6	47.8	0.6	27.0	0.6	45.7	
0.8	54.5	0.8	39.9	0.8	61.0	
1.0	56.7	1.0	56.7	1.0	76.2	

- Notes: 1) "d" is depth from the top of water. "H" is water height of the pool (6.7 m).
 2) "x" is distance from the center of the pool. "L" is width of the pool.
 3) Floor pressure due to vertical motion is for reference only. It is already included in vertical seismic loads for the floor.



Table 5.3.3-14 Sloshing Loads for IC / PCCS Pool

NS / EW Motion				Vertical Motion		
Wall		Floor		Wall		Floor
Depth d/H	Pressure (kN/m ²)	Depth d/H	Pressure (kN/m ²)	Depth d/H	Pressure (kN/m ²)	Pressure (kN/m ²)
0.0	9.1	0.0	0.0	0.0	0.0	54.6 for all floor area
0.2	13.6	0.2	4.6	0.2	10.9	
0.4	21.7	0.4	9.5	0.4	21.8	
0.6	26.7	0.6	14.8	0.6	32.8	
0.8	28.2	0.8	21.0	0.8	43.7	
1.0	28.2	1.0	28.2	1.0	54.6	

- Notes: 1) "d" is depth from the top of water. "H" is water height of the pool (4.8 m).
 2) "x" is distance from the center of the pool. "L" is width of the pool.
 3) Floor pressure due to vertical motion is for reference only. It is already included in vertical seismic loads for the floor.

Table 5.3.3-15 Sloshing Loads for Extension Pool A

NS Motion				EW Motion				Vertical Motion		
Wall		Floor		Wall		Floor		Wall		Floor
Depth d/H	Pressure (kN/m ²)	Distance x/(L/2)	Pressure (kN/m ²)	Depth d/H	Pressure (kN/m ²)	Distance x/(L/2)	Pressure (kN/m ²)	Depth d/H	Pressure (kN/m ²)	Pressure (kN/m ²)
0.0	4.8	0.0	0.0	0.0	7.8	0.0	0.0	0.0	0.0	54.6 for all floor area
0.2	16.5	0.2	1.3	0.2	12.9	0.2	3.9	0.2	10.9	
0.4	28.6	0.4	2.7	0.4	20.3	0.4	8.1	0.4	21.8	
0.6	37.3	0.6	4.7	0.6	23.8	0.6	12.6	0.6	32.8	
0.8	42.5	0.8	12.3	0.8	24.0	0.8	17.8	0.8	43.7	
1.0	44.3	1.0	44.3	1.0	24.0	1.0	24.0	1.0	54.6	

- Notes: 1) "d" is depth from the top of water. "H" is water height of the pool (4.8 m).
 2) "x" is distance from the center of the pool. "L" is width of the pool.
 3) Floor pressure due to vertical motion is for reference only. It is already included in vertical seismic loads for the floor.



Table 5.3.3-16 Sloshing Loads for Extension Pool B

NS Motion				EW Motion				Vertical Motion		
Wall		Floor		Wall		Floor		Wall		Floor
Depth d/H	Pressure (kN/m ²)	Distance x/(L/2)	Pressure (kN/m ²)	Depth d/H	Pressure (kN/m ²)	Distance x/(L/2)	Pressure (kN/m ²)	Depth d/H	Pressure (kN/m ²)	Pressure (kN/m ²)
0.0	7.8	0.0	0.0	0.0	13.7	0.0	0.0	0.0	0.0	54.6 for all floor area
0.2	12.5	0.2	3.5	0.2	18.2	0.2	5.5	0.2	10.9	
0.4	19.2	0.4	7.2	0.4	27.8	0.4	11.7	0.4	21.8	
0.6	21.5	0.6	11.3	0.6	35.5	0.6	19.1	0.6	32.8	
0.8	21.5	0.8	16.0	0.8	40.3	0.8	28.7	0.8	43.7	
1.0	21.5	1.0	21.5	1.0	41.9	1.0	41.9	1.0	54.6	

- Notes: 1) "d" is depth from the top of water. "H" is water height of the pool (4.8 m).
 2) "x" is distance from the center of the pool. "L" is width of the pool.
 3) Floor pressure due to vertical motion is for reference only. It is already included in vertical seismic loads for the floor.

Table 5.3.3-17 Sloshing Loads for Spent Fuel Pool

NS Motion				EW Motion				Vertical Motion		
Wall		Floor		Wall		Floor		Wall		Floor
Depth d/H	Pressure (kN/m ²)	Distance x/(L/2)	Pressure (kN/m ²)	Depth d/H	Pressure (kN/m ²)	Distance x/(L/2)	Pressure (kN/m ²)	Depth d/H	Pressure (kN/m ²)	Pressure (kN/m ²)
0.0	12.3	0.0	0.0	0.0	11.8	0.0	0.0	0.0	0.0	98.5 for all floor area
0.2	23.6	0.2	7.4	0.2	24.2	0.2	8.5	0.2	19.7	
0.4	37.8	0.4	15.2	0.4	40.0	0.4	17.5	0.4	39.4	
0.6	44.6	0.6	23.7	0.6	49.4	0.6	27.4	0.6	59.1	
0.8	45.2	0.8	33.6	0.8	52.2	0.8	38.7	0.8	78.8	
1.0	45.2	1.0	45.2	1.0	52.2	1.0	52.2	1.0	98.5	

- Notes: 1) "d" is depth from the top of water. "H" is water height of the pool (14.35 m).
 2) "x" is distance from the center of the pool. "L" is width of the pool.
 3) Floor pressure due to vertical motion is for reference only. It is already included in vertical seismic loads for the floor.



Table 5.3.3-18 RPV Reactions Due to SSE

		Seismic
Vertical	(MN)	24.75
Shear	(MN)	29.8
Moment	(MNm)	182.7

Table 5.3.3-19 Enveloping Maximum Horizontal Acceleration: RBFB Wall Out-of-plane Oscillators

Elev. (m)	Node No.	Stick Model	Max. Horizontal Acceleration (g)	Portion
42.00 (X-dir)	99981	Oscillator	2.71	R1 and R7 walls
	99982	Oscillator	1.54	
	99986	Oscillator	0.89	
42.00 (Y-dir)	99983	Oscillator	1.86	RB and RF walls
	99984	Oscillator	1.02	
	99985	Oscillator	1.00	
	99987	Oscillator	0.59	
30.50 (X-dir)	99991	Oscillator	0.58	R1 and R7 walls
30.50 (Y-dir)	99992	Oscillator	0.56	RB and RF walls
13.57 (X-dir)	99971	Oscillator	2.11	F3 walls
	99972	Oscillator	2.29	
	99973	Oscillator	1.88	
	99974	Oscillator	1.13	
	99977	Oscillator	0.89	
13.57 (Y-dir)	99975	Oscillator	2.16	FA and FF walls
	99976	Oscillator	0.93	
	99978	Oscillator	0.97	

Note: Bounding Equivalent Out-of-plane Acceleration Loads on Walls are shown in RB/FB Seismic Analyses Bounding Results and In-Structure Response Spectra. (Table 4.5-2 of Reference 2.1.2-k)



HITACHI

WG3-U71-ERD-S-0004 SH NO. 91
REV. 0 of 538

Table 6.2.2-1 List of GA Drawings Used for Modeling

Title	Drawing #	Revision
General Arrangement - ESBWR PLOT PLAN	105E3968 SH01	-
General Arrangement - ESBWR EL -11500	105E3908 SH01	5
General Arrangement - ESBWR EL -6400	105E3908 SH02	5
General Arrangement - ESBWR EL -1000	105E3908 SH03	5
General Arrangement - ESBWR EL 4650	105E3908 SH04	5
General Arrangement - ESBWR EL 9060	105E3908 SH05	5
General Arrangement - ESBWR EL 13570	105E3908 SH06	5
General Arrangement - ESBWR EL 17500	105E3908 SH07	5
General Arrangement - ESBWR EL 27000	105E3908 SH08	5
General Arrangement - ESBWR EL 34000	105E3908 SH09	5
General Arrangement - ESBWR SECTION "A-A"	105E3908 SH10	5
General Arrangement - ESBWR SECTION "B-B"	105E3908 SH11	5

**Table 6.2.2-2 Structural Members Considered in Analyses and Their Design**

Structural Members		Included in Global FE Model	Designed using Global FEM Analysis Results
Basemat		○	○
RCCV		○	○
Liner		○	○
Penetration Sleeve		○	
Pool*		○	○
Walls	Outer Seismic Walls	○	○
	Inner Seismic Walls	○	○
	Other Walls	RB Cylindrical Wall Walls around Pools	RB Cylindrical Wall Walls around Pools
Floor Slabs		○	○
Frames	Columns	○	○
	Girders	○	○
	RB Roof Main Trusses	○	○
	RB Roof Sub-trusses		
RCCV Internal Structures		○	○

Note*: Pool includes walls and slabs of the reactor cavity pool, the dryer/separator pool, the fuel buffer pool, IC/PCCS pool, and IC/PCCS expansion pool.



Table 6.2.2-3 Type of Elements Used to Model Structural Members

Structural Members	Element Type	Forces Considered
RCCV Basemat Pool Wall Slab	Thick Shell Element	Membrane Force In-plane Shear Force Bending Moment Transverse Shear Force
Liner	Membrane Element	Membrane Force In-plane Shear Force
Column Girder Roof Truss	Bar Element	Axial Force Bending Moment Transverse Shear Force
Penetration Sleeve	Rod Element	Axial Force



Table 6.2.2-4 Local Coordinate Systems

Structure	z-direction
RCCV Wall RPV Pedestal External Wall	outward
Wall in N-S Direction	toward West
Wall in E-W Direction	toward South
Basemat Floor Slab Top Slab Suppression Pool Slab	downward

**Table 6.2.2-5 Soil Spring Constants for the RB Analysis Model**

Loads		Soil Spring Constants (MN/m/m ²)		
		Horizontal		Vertical
		NS-direction	EW-direction	
for All Loads except for Seismic Loads		9.107	9.654	13.66
for Seismic Loads	Horizontal	9.107	9.654	38.35
	Vertical, Torsion	9.107	9.654	13.66

Table 6.2.2-6 Levels of Floor Slabs Connected to the RCCV Wall

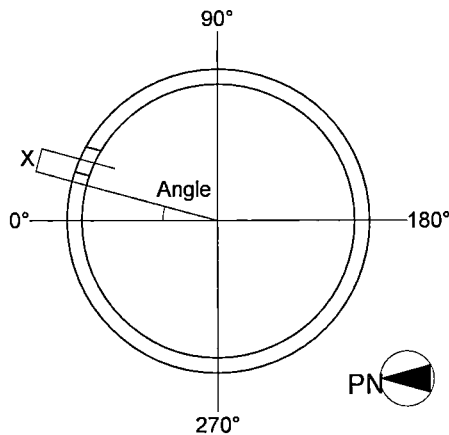
Story	Elevation	Item	t (mm)	Modeled Slab Level
5F	27000	Top Slab	2400	25800
4F	17500	DF Slab	600	17200
3F	13570	Slab around Containment	1000	13070
2F	9060	Slab around Containment	1000	8560
1F	4650	Suppression Pool Floor Slab	2000	3650
B1F	-1000	Slab around Containment	1000	-1500
B2F	-6400	Slab around Containment	1000	-6900
B3F	-11500	Basemat	4000	-13500



Table 6.2.2-7 Dimensions of Modeled Round Openings on RCCV

Portion	Opening	Diameter (m)	Angle* (°)	X* (m)	Elevation at Center (EL m)	
RPV	Lower Drywell Personnel Airlock	2.432	0	0.0	-5.350	
Pedestal	Lower Drywell Equipment Hatch	2.432	180	0.0	-5.600	
RCCV	Wetwell Hatch	2.032	115	0.0	14.450	
	Upper Drywell Personnel Airlock	2.432	52	0.0	19.505	
	Upper Drywell Equipment Hatch	2.432	307	0.0	18.570	
	Main Steam Lines		1.200	0	4.2	19.150
			1.200	0	1.4	19.150
			1.200	0	-1.4	19.150
			1.200	0	-4.2	19.150
	Feed Water Lines		0.965	0	6.3	20.349
0.965			0	6.3	20.349	

Note *: See figure below



**Table 6.2.2-8 Material and Thickness of the RCCV Liner**

Portion	Material	Thickness (mm)
Drywell Cylinder	Carbon Steel	6.4
Wetwell Cylinder	Stainless Steel	6.4
Topslab Flat Plate	Carbon Steel	6.4
Wetwell Floor Plate	Stainless Steel	16.0
Lower Drywell Bottom Plate	Carbon Steel	6.4

Table 6.2.2-9 Area of Rod Elements Used in Sleeve Models

Opening	Sleeve Thickness t (mm)	Concrete Thickness w (m)	Area of Rod Element $Ar = tw$ (m ²)
Top Head	50.0	2.4	0.120

Table 6.2.2-10 Dimensions of Modeled Rectangular Openings on RB Walls

Portion	Opening	Width (m)	height (m)	Position	
				NS	EW
Wall below RCCV		3.0	3.5	R6	RD~RE
Inner Wall		3.5	3.5	R7	FC~FD
Exterior Wall	Equipment Hatch Access Opening	3.0	3.0	R4~R5	RG
		3.0	3.0	R4~R5	RG
		7.5	6.0	R4~R5	RF



**Table 6.2.2-11 Material Constants Used in Stress Analysis
(Reproduced from Reference 2.1.2-e)**

		Temperature (°C)	Reinforced Concrete			Steel			Note
			Basemat f'c=4000psi 27.6MPa	Others f'c=5000psi 34.5MPa	Top Slab f'c=6000psi 41.4MPa	Carbon Steel Liner	Stainless Steel Liner	Structural Steel	
Young's Modulus (MPa)	Thermal Loads*2	<21	2.49x10 ⁴	2.78x10 ⁴	3.04x10 ⁴	2.00x10 ⁵			Concrete: See Notes 1 & 2.
		93	1.81x10 ⁴	2.03x10 ⁴	2.22x10 ⁴				
		204	1.62x10 ⁴	1.81x10 ⁴	1.98x10 ⁴				
	Other Loads*1	2.49x10 ⁴	2.78x10 ⁴	3.04x10 ⁴	2.00x10 ¹ *3	2.00x10 ⁵			
Poisson's Ratio			0.17			0.3			
Thermal Expansion (m/m°C)			9.90x10 ⁻⁶			1.17x10 ⁻⁵	1.52x10 ⁻⁵	1.17x10 ⁻⁵	
Weight Density (MN/m3)			0.0235			0.0770			

Notes *1: Young's modulus of concrete is calculated in accordance with ACI 349-01, Section 8.5.1.

$$Ec = 57,000\sqrt{f'_c}$$

*2: Reduction factors of Young's modulus for concrete are determined based upon the average values of the following upper bound and lower bound equations. (See table and figure below.)

Lower bound:

$$\phi = 1.0 - 0.0038(T - 70) \quad 70^\circ F \leq T \leq 200^\circ F$$

$$= 0.50 - 0.0005(T - 200) \quad 200^\circ F \leq T$$

Upper bound:

$$\phi = 1.0 - 0.00031(T - 70) \quad 70^\circ F \leq T \leq 400^\circ F$$

$$= 0.90 - 0.00084(T - 400) \quad 400^\circ F \leq T$$

*3: Except for the local thickened portions of the liner where the diaphragm floor, vent wall and RPV support brackets are attached. The full value of the Young's modulus is considered for these thickened liners

**Table 6.2.3.2-1 Floor Live Loads**

Elevation (m)	Area Load (kN/m ²)		Remarks
	RB	FB	
52.40 ^{*1}	2.9	-	RB Roof
34.00	4.8	-	Indoor Slab
	See Figure 6.2.3.2-1	-	Roof Slab
27.50	-	See Figure 6.2.3.2-1	FB Roof Slab of penthouse
27.00	4.8 ^{*2}	-	
	2.9	-	Main Steam Tunnel Roof
22.50	-	2.9	
17.50	4.8	-	
	0.0	-	Main Steam Tunnel Floor
13.57	4.8	-	
9.06	4.8	-	
4.65	4.8	4.8	
-1.00	4.8	4.8	
-6.40	4.8	4.8	
-11.50	4.8	4.8	

Note

- *1: The difference between the modeled elevation 52.4 m and the actual elevation 52.7 m at the RB roof is negligibly small.
- *2: Live load at pool water area is zero.



Table 6.2.3.3-1 Load Combinations for Design Pressure Loads

			Drywell*1	Wetwell*1	IC/PCCS*1	Main Steam Tunnel*1	note
		Label	PDW	PSC	PIC	PMS	
TEST	Max.	PTL1	0.3568	0.3568			
	Diff.	PTL2	0.3100	0.0325			Max. Differential Pressure 277.5kPa
Normal Operation		POL	0.0090	0.0090	0.0345		
LOCA	After 5 seconds	PL1	0.0000	0.0000	0.0483		Period-I
	After 6 minutes	PL2	0.2570	0.2410	0.0483		Period-II
	After 10 hours	PL3	0.3100	0.3100	0.0483		Period-IV
	After 72 hours	PL4	0.3100	0.3100	0.0483		Period-IV
HELB		PLMS				0.0760	HELB in MS Tunnel

Note: *1: Unit pressure load, 1.0 MPa, is applied to each space in stress analyses.



Table 6.2.3.4-1 Atmosphere Temperatures: Summer

Region		Index *1	Atmosphere Temperature (°C)				
			Normal Operation	LOCA			
				5 sec.	6 min.	10 hr.	72 hr.
RB Inside Containment	Drywell	DW	57.0	133.7	171.0	150.0	150.0
	GDCS pool	GP	43.0	43.0	43.0	110.0	110.0
	Wetwell	WW	43.0	86.2	130.0	121.0	121.0
	Suppression pool	SP	43.0	43.0	110.0	110.0	110.0
RB Outside Containment	RB rooms outside containment	RM	40.0	40.0	40.0	40.0	40.0
	Reactor Cavity pool	DP	43.0	43.0	43.0	43.0	43.0
	Dryer/Separator Storage pool	DP	43.0	43.0	43.0	43.0	43.0
	Fuel Buffer pool	DP	43.0	43.0	43.0	43.0	43.0
	IC/PCCS pool	IP	43.0	43.0	70.0	110.0	110.0
	Expansion pool	XP	43.0	43.0	67.8	110.0	110.0
	Mainsteam tunnel	MT	57.0	57.0	57.0	57.0	57.0
FB	FB rooms	RM	40.0	40.0	40.0	40.0	40.0
	Spent Fuel pool*2	FP	48.9 (100.0)	48.9 (100.0)	48.9 (100.0)	48.9 (100.0)	48.9 (100.0)
	Air	AT	46.1	46.1	46.1	46.1	46.1
	Ground	GR	15.5	15.5	15.5	15.5	15.5

Note*1: DW: Drywell
 WW: Wetwell
 SP: Suppression Pool
 GP: GDCS Pool
 IP: IC/PCCS Pool
 XP: Expansion Pool
 RM: Room
 FP: Spent Fuel Pool
 DP: DS/Fuel Pool, Reactor Cavity
 MT: Main Steam Tunnel
 GR: Ground
 AT: Outer Air

Note*2: Temperature in parentheses indicates temperature at 72 hours after loss of FAPCS cooling function resulting from a DBA.



Table 6.2.3.4-2 Atmosphere Temperatures: Winter

Region		Index ^{*1}	Atmosphere Temperature (°C)				
			Normal Operation	LOCA			
				5 sec.	6 min.	10 hr.	72 hr.
RB Inside Containment	Drywell	DW	57.0	133.7	171.0	150.0	150.0
	GDCS pool	GP	43.0	43.0	43.0	110.0	110.0
	Wetwell	WW	43.0	86.2	130.0	121.0	121.0
	Suppression pool	SP	43.0	43.0	110.0	110.0	110.0
RB Outside Containment	RB rooms outside containment	RM	10.0	10.0	10.0	10.0	10.0
	Reactor Cavity pool	DP	43.0	43.0	43.0	43.0	43.0
	Dryer/Separator Storage pool	DP	43.0	43.0	43.0	43.0	43.0
	Fuel Buffer pool	DP	43.0	43.0	43.0	43.0	43.0
	IC/PCCS pool	IP	43.0	43.0	70.0	110.0	110.0
	Expansion pool	XP	43.0	43.0	67.8	110.0	110.0
	Mainsteam tunnel	MT	57.0	57.0	57.0	57.0	57.0
FB	FB rooms	RM	10.0	10.0	10.0	10.0	10.0
	Spent Fuel pool ^{*2}	FP	48.9 (100.0)	48.9 (100.0)	48.9 (100.0)	48.9 (100.0)	48.9 (100.0)
	Air	AT	-40.0	-40.0	-40.0	-40.0	-40.0
	Ground	GR	15.5	15.5	15.5	15.5	15.5

Note*1: DW: Drywell
 WW: Wetwell
 SP: Suppression Pool
 GP: GDCS Pool
 IP: IC/PCCS Pool
 XP: Expansion Pool
 RM: Room
 FP: Spent Fuel Pool
 DP: DS/Fuel Pool, Reactor Cavity
 MT: Main Steam Tunnel
 GR: Ground
 AT: Outer Air

Note*2: Temperature in parentheses indicates temperature at 72 hours after loss of FAPCS cooling function resulting from a DBA.



Table 6.2.3.4-3 Application of Thermal Loads: List of Indexes

Portion	Location	Index			note
		RCCV	RB	FB	
RCCV	Shell	*	-	-	Figure 6.2.3.4-1~4
	RPV Pedestal	RP1	-	-	
		RP2			During LOCA Flooding
	Basemat	*	*	*	Figure 6.2.3.4-12~13
	Suppression Pool Slab	*	-	-	Figure 6.2.3.4-14
	Topslab	*	-	-	Figure 6.2.3.4-16
External Wall	column line RA/FA	-	*	*	Figure 6.2.3.4-5
	column line RB	-	*	-	Figure 6.2.3.4-7
	column line RF	-	*	-	Figure 6.2.3.4-8
	column line RG/FF	-	*	*	Figure 6.2.3.4-6
	column line R1	-	*	-	Figure 6.2.3.4-9
	column line R7/F1	-	*	*	Figure 6.2.3.4-10
	column line F3	-	-	*	Figure 6.2.3.4-11
Slab	EL -6400	-	SL1	SL1	
	EL -1000	-	SL1	SL1	
	EL 4650	-	*	*	Figure 6.2.3.4-13
	EL 9060	-	SL1	-	
	EL 13570	-	SL1	-	
	EL 17500	-	*	-	Figure 6.2.3.4-15
	EL 22500	-	-	SL1	
	EL 27000	-	*	-	Figure 6.2.3.4-16
	EL 34000	-	*	-	Figure 6.2.3.4-17
EL 52400 ^{*1}	-	SL7	-		

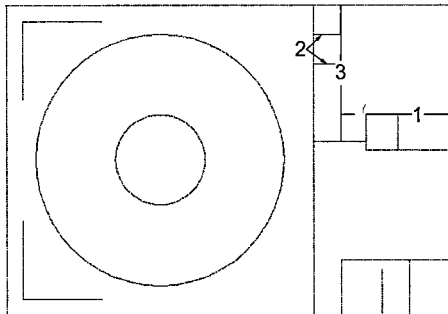
Note *: See Figures shown in note.

*1: The difference between the modeled elevation 52.4 m and the actual elevation 52.7 m at the RB roof is negligibly small.

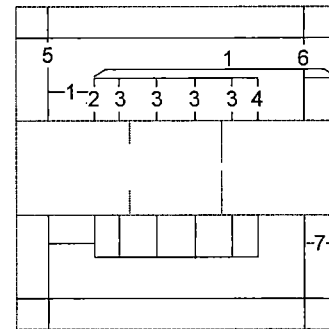


Table 6.2.3.4-3 Application of Thermal Loads: List of Indexes (Continued)

Portion	Location	Index			note
		RCCV	RB	FB	
Inner Wall	Wall1 around Spent Fuel Pool	-	-		Figure 6.2.3.4-18
	Wall2 around Spent Fuel Pool	-	-		Figure 6.2.3.4-19
	Wall3 around Spent Fuel Pool	-	-		Figure 6.2.3.4-20
	Wall1 around IC/PCCS Pool	-	*	-	Figure 6.2.3.4-23~24
	Wall2 around IC/PCCS Pool	-	PW3	-	
	Wall3 around IC/PCCS Pool	-	PW2	-	
	Wall4 around IC/PCCS Pool	-	PW5	-	
	Wall5 around IC/PCCS Pool	-	*	-	Figure 6.2.3.4-25
	Wall6 around IC/PCCS Pool	-	*	-	Figure 6.2.3.4-26
	Wall7 around IC/PCCS Pool	-	PW10	-	
	Other	-	IW1	IW1	
Pool Girder		-	*	-	Figure 6.2.3.4-22
Reactor Cavity Wall		-	PW1	-	
Main Steam Tunnel		-	*	-	Figure 6.2.3.4-15 Figure 6.2.3.4-16 Figure 6.2.3.4-21
Liner	Shell	*	-	-	Figure 6.2.3.4-27~30
	RPV Pedestal	RPL1	-	-	
	Basemat	MTL1	-	-	
	Suppression Pool Slab	CVL2	-	-	
	Topslab	CVL4	-	-	



Spent Fuel Pool Walls



IC/PCCS Pool and Expansion Pool Walls

Note *: See Figures shown in note.



**Table 6.2.3.4-4 Thermal Loads for Shell Elements
Normal Operation: Summer**

Location	Index	Boundary*		Thickness (mm)	Td (°C)	Tg (°C)	note	
		1	2					
Basemat	BM1	RM	GR	4000	27.07	23.15	General	
	BM2	DW	GR	5100	27.47	23.94	below lower Drywell	
	BM4	DW	FL	5100	-	-	at LOCA Flooding	
	BM6	FP	GR	5500	32.20	33.40	below Spent Fuel Pool	
	BM7	FP	GR	4000	32.20	33.40	Skimmer Surge Tank	
RCCV Wall	CV1	RM	RM	2000	40.00	0.00	below Grade	
	CV2	SP	RM	2000	41.66	2.68	Suppression Pool	
	CV3	WW	RM	2000	41.50	2.43	Wetwell Air Space	
	CV4	DW	RM	2000	48.50	13.77	Drywell General	
	CV5	GP	RM	2000	41.66	2.69	Drywell GDCS Pool	
	CV6	DW	MT	2000	57.00	0.00	Drywell MS Tunnel	
Suppression Pool Slab	SP1	SP	RM	2000	41.66	2.68		
Top Slab	TS1	DW	DP	2400	49.38	12.75	below DSP/FP	
	TS2	DW	IP	2400	49.38	12.75	below IC/PCCS	
	TS3	DW	XP	2400	49.38	12.75	below Expansion Pool	
	TS4	DW	DP	2400	50.81	12.61	around Drywell Head	
	TS5	DW	RM	2400	48.50	14.23	below Room	
RPV Pedestal	RP1	DW	RM	2400	48.50	14.23		
	RP2	FL	RM	2400	-	-	at LOCA Flooding	
Pool Girder	PG1	IP	DP	1600	43.00	0.00		
	PG2	XP	DP	1600	43.00	0.00		
	PG3	DP	RM	1600	41.69	2.62		
Pool Gate Wall IC/PCCS Pool Wall Expansion Pool Wall	PW1	DP	DP	1300	43.00	0.00		
	PW2	IP	IP	400	43.00	0.00		
	PW4	IP	XP	600	43.00	0.00		
	PW6	XP	XP	1000	43.00	0.00		
	PW7	XP	XP	2000	43.00	0.00		
	PW8	XP	RM	1000	41.78	2.43		
	PW9	XP	RM	2000	41.66	2.68		
	PW10	RM	RM	1000	40.00	0.00		
	PW11	RM	RM	2000	40.00	0.00		
	PW12	IP	XP	1000	43.00	0.00		
	PW13	IP	RM	1000	41.79	2.42		
	PW14	IP	XP	470	43.00	0.00		
	Spent Fuel Pool Wall**	FP7	FP	RM	1500	45.05	7.70	
		FP8	FP	RM	1900	44.94	7.92	
FP9		FP	RM	1750	44.97	7.85	around Skimmer Surge Tank	
FP10		FP	RM	2000	44.91	-7.96		
FP11		FP	FP	1900	48.90	0.00		
FP12		FP	FP	1750	48.90	0.00	between Skimmer Surge Tanks	

*: See footnotes in Table 6.2.3.4-1.

** : The spent fuel pool is normal condition



**Table 6.2.3.4-4 Thermal Loads for Shell Elements
Normal Operation: Summer (Continued)**

Location	Index	Boundary*		Thickness (mm)	Td (°C)	Tg (°C)	note
		1	2				
Outer Wall	BW1	RM	GR	2000	26.47	21.94	below Grade General
	BW4	RM	RM	2000	40.00	0.00	below Grade Stair Case
	BW5	FP	GR	2000	32.19	33.39	below Grade Spent Fuel Pool
	BW6	FP	GR	3600	32.20	33.39	
	GW1	RM	AT	1500	43.37	-5.14	EL 4650 ~ 27000 General
	GW2	RM	RM	1500	40.00	0.00	EL 4650 ~ 27000 Stair Case
	GW3	XP	AT	1000	44.48	-2.96	EL 27000 ~ IC/PCCS Pool
	GW5	DP	AT	3000	44.52	-3.04	
	GW6	DP	AT	3500	44.53	-3.06	
	GW7	XP	AT	1500	44.50	-3.01	
	GW8	XP	RM	1000	41.78	2.43	EL 27000 ~ Stair Case/Pool
	GW9	RM	AT	1000	43.49	-4.77	EL 27000 ~ Room
GW10	RM	RM	1000	40.00	0.00	EL 27000 ~ Stair Case	
GW11	DP	AT	1500	44.53	-3.05		
MS Tunnel	MT1	MT	RM	1300	48.50	12.51	Wall inside Building
	MT2	MT	AT	1300	50.91	8.97	Wall outside Building
	MT4	MT	RM	1600	48.50	13.16	Slab inside Building
	MT5	MT	DP	2400	49.38	12.76	
	MT6	XP	MT	2400	49.38	-12.75	
	MT7	MT	AT	1600	51.01	9.28	Slab outside Building
	MT8	MT	AT	2400	51.17	9.76	
	MT9	MT	RM	2400	48.50	14.23	
	Inner Wall	IW1	RM	RM	-	40.00	0.00
Slab	SL1	RM	RM	-	40.00	0.00	General
	SL2	IP	RM	1000	41.50	2.04	below & above IC/PCCS Pool
	SL3	XP	RM	1000	41.50	2.04	
	SL4	DP	RM	1000	41.78	2.43	
	SL5	RM	AT	1000	43.49	-4.77	RB Roof at EL 34000
	SL6	XP	AT	1000	44.48	-2.96	
	SL7	RM	AT	700	43.63	-4.36	RB Roof at EL 57400
	SL8	RM	AT	700	43.63	-4.36	FB Roof at EL 22500
RCCV Liner	CVL2				43.00	0.00	Suppression Pool
	CVL3				43.00	0.00	Wetwell Air Space
	CVL4				57.00	0.00	Drywell General
	CVL5				43.00	0.00	Drywell GDCS Pool
RPV Pedestal & Basemat Liner	RPL1				57.00	0.00	
	RPL2				-	-	at LOCA Flooding
MAT Liner	MTL1				46.02	0.00	Lower Drywell

*: See footnotes in Table 6.2.3.4-1.



**Table 6.2.3.4-5 Thermal Loads for Shell Elements
LOCA: 5 sec.: Summer**

Location	Index	Boundary*		Thickness (mm)	Td (°C)	Tg (°C)	note	
		1	2					
Basemat	BM1	RM	GR	4000	27.07	23.15	General	
	BM2	DW	GR	5100	27.47	23.94	below lower Drywell	
	BM4	DW	FL	5100	27.47	23.94	at LOCA Flooding	
	BM6	FP	GR	5500	32.20	33.40	below Spent Fuel Pool	
	BM7	FP	GR	4000	32.20	33.40	Skimmer Surge Tank	
RCCV Wall	CV1	RM	RM	2000	40.00	0.00	below Grade	
	CV2	SP	RM	2000	41.66	2.69	Suppression Pool	
	CV3	WW	RM	2000	41.61	3.06	Wetwell Air Space	
	CV4	DW	RM	2000	48.84	15.79	Drywell General	
	CV5	GP	RM	2000	41.66	2.69	Drywell GDCS Pool	
	CV6	DW	MT	2000	57.33	1.97	Drywell MS Tunnel	
Suppression Pool Slab	SP1	SP	RM	2000	41.66	2.68		
Top Slab	TS1	DW	DP	2400	49.72	14.76	below DSP/FP	
	TS2	DW	IP	2400	49.72	14.76	below IC/PCCS	
	TS3	DW	XP	2400	49.72	14.76	below Expansion Pool	
	TS4	DW	DP	2400	51.23	15.08	around Drywell Head	
	TS5	DW	RM	2400	48.84	16.23	below Room	
RPV Pedestal	RP1	DW	RM	2400	48.84	16.23		
	RP2	FL	RM	2400	48.94	16.83	at LOCA Flooding	
Pool Girder	PG1	IP	DP	1600	43.00	0.00		
	PG2	XP	DP	1600	43.00	0.00		
	PG3	DP	RM	1600	41.69	2.62		
Pool Gate Wall	PW1	DP	DP	1300	43.00	0.00		
IC/PCCS Pool Wall	PW2	IP	IP	400	43.00	0.00		
Expansion Pool Wall	PW4	IP	XP	600	43.00	0.00		
	PW6	XP	XP	1000	43.00	0.00		
	PW7	XP	XP	2000	43.00	0.00		
	PW8	XP	RM	1000	41.78	2.43		
	PW9	XP	RM	2000	41.66	2.69		
	PW10	RM	RM	1000	40.00	0.00		
	PW11	RM	RM	2000	40.00	0.00		
	PW12	IP	XP	1000	43.00	0.00		
	PW13	IP	RM	1000	41.79	2.42		
	PW14	IP	XP	470	43.00	0.00		
	Spent Fuel Pool Wall**	FP7	FP	RM	1500	45.05	7.70	
		FP8	FP	RM	1900	44.94	7.92	
FP9		FP	RM	1750	44.97	7.85	around Skimmer Surge Tank	
FP10		FP	RM	2000	44.91	-7.96		
FP11		FP	FP	1900	48.90	0.00		
FP12		FP	FP	1750	48.90	0.00	between Skimmer Surge Tanks	

*: See footnotes in Table 6.2.3.4-1.

** : The spent fuel pool is normal condition



**Table 6.2.3.4-5 Thermal Loads for Shell Elements
LOCA: 5 sec.: Summer (Continued)**

Location	Index	Boundary*		Thickness (mm)	Td (°C)	Tg (°C)	note
		1	2				
Outer Wall	BW1	RM	GR	2000	26.47	21.94	below Grade General
	BW4	RM	RM	2000	40.00	0.00	below Grade Stair Case
	BW5	FP	GR	2000	32.19	33.39	below Grade Spent Fuel Pool
	BW6	FP	GR	3600	32.20	33.39	
	GW1	RM	AT	1500	43.37	-5.14	EL 4650 ~ 27000 General
	GW2	RM	RM	1500	40.00	0.00	EL 4650 ~ 27000 Stair Case
	GW3	XP	AT	1000	44.48	-2.96	EL 27000 ~ IC/PCCS Pool
	GW5	DP	AT	3000	44.52	-3.04	
	GW6	DP	AT	3500	44.53	-3.06	
	GW7	XP	AT	1500	44.50	-3.01	
	GW8	XP	RM	1000	41.78	2.43	EL 27000 ~ Stair Case/Pool
	GW9	RM	AT	1000	43.49	-4.77	EL 27000 ~ Room
GW10	RM	RM	1000	40.00	0.00	EL 27000 ~ Stair Case	
GW11	DP	AT	1500	44.53	-3.05		
MS Tunnel	MT1	MT	RM	1300	48.50	12.51	Wall inside Building
	MT2	MT	AT	1300	50.91	8.97	Wall outside Building
	MT4	MT	RM	1600	48.50	13.16	Slab inside Building
	MT5	MT	DP	2400	49.38	12.76	
	MT6	XP	MT	2400	49.38	-12.75	
	MT7	MT	AT	1600	51.01	9.28	Slab outside Building
	MT8	MT	AT	2400	51.17	9.76	
	MT9	MT	RM	2400	48.50	14.23	
	Inner Wall	IW1	RM	RM	-	40.00	0.00
Slab	SL1	RM	RM	-	40.00	0.00	General
	SL2	IP	RM	1000	41.50	2.05	below & above IC/PCCS Pool
	SL3	XP	RM	1000	41.50	2.05	
	SL4	DP	RM	1000	41.78	2.43	
	SL5	RM	AT	1000	43.49	-4.77	RB Roof at EL 34000
	SL6	XP	AT	1000	44.48	-2.96	
	SL7	RM	AT	700	43.63	-4.36	RB Roof at EL 57400
	SL8	RM	AT	700	43.63	-4.36	FB Roof at EL 22500
RCCV Liner	CVL2				43.00	0.00	Suppression Pool
	CVL3				86.20	0.00	Wetwell Air Space
	CVL4				133.67	0.00	Drywell General
	CVL5				43.00	0.00	Drywell GDCS Pool
RPV Pedestal & Basemat Liner	RPL1				133.67	0.00	
	RPL2				145.00	0.00	at LOCA Flooding
MAT Liner	MTL1				46.02	0.00	Lower Drywell

*: See footnotes in Table 6.2.3.4-1.



**Table 6.2.3.4-6 Thermal Loads for Shell Elements
LOCA: 6 min.: Summer**

Location	Index	Boundary*		Thickness (mm)	Td (°C)	Tg (°C)	note
		1	2				
Basemat	BM1	RM	GR	4000	27.07	23.15	General
	BM2	DW	GR	5100	27.47	23.94	below lower Drywell
	BM4	DW	FL	5100	27.47	23.94	at LOCA Flooding
	BM6	FP	GR	5500	32.20	33.40	below Spent Fuel Pool
	BM7	FP	GR	4000	32.20	33.40	Skimmer Surge Tank
RCCV Wall	CV1	RM	RM	2000	40.00	0.00	below Grade
	CV2	SP	RM	2000	42.20	5.89	Suppression Pool
	CV3	WW	RM	2000	42.36	7.49	Wetwell Air Space
	CV4	DW	RM	2000	49.67	20.71	Drywell General
	CV5	GP	RM	2000	41.66	2.69	Drywell GDCS Pool
	CV6	DW	MT	2000	58.16	6.84	Drywell MS Tunnel
Suppression Pool Slab	SP1	SP	RM	2000	42.14	5.53	
Top Slab	TS1	DW	DP	2400	50.40	18.79	below DSP/FP
	TS2	DW	IP	2400	50.59	17.62	below IC/PCCS
	TS3	DW	XP	2400	50.58	17.72	below Expansion Pool
	TS4	DW	DP	2400	53.41	18.97	around Drywell Head
	TS5	DW	RM	2400	49.52	20.25	below Room
RPV Pedestal	RP1	DW	RM	2400	49.52	20.25	
	RP2	FL	RM	2400	49.29	18.91	at LOCA Flooding
Pool Girder	PG1	IP	DP	1600	43.26	1.52	
	PG2	XP	DP	1600	43.24	1.40	
	PG3	DP	RM	1600	41.69	2.62	
Pool Gate Wall	PW1	DP	DP	1300	43.00	0.00	
IC/PCCS Pool Wall	PW2	IP	IP	400	44.89	0.00	
	PW4	IP	XP	600	44.21	0.30	
Expansion Pool Wall	PW6	XP	XP	1000	43.71	0.00	
	PW7	XP	XP	2000	43.40	0.00	
	PW8	XP	RM	1000	42.14	4.49	
	PW9	XP	RM	2000	41.86	3.87	
	PW10	RM	RM	1000	40.00	0.00	
	PW11	RM	RM	2000	40.00	0.00	
	PW12	IP	XP	1000	43.74	0.19	
	PW13	IP	RM	1000	42.17	4.69	
	PW14	IP	XP	470	44.54	0.38	
	Spent Fuel Pool Wall**	FP7	FP	RM	1500	45.05	7.70
FP8		FP	RM	1900	44.94	7.92	
FP9		FP	RM	1750	44.97	7.85	around Skimmer Surge Tank
FP10		FP	RM	2000	44.91	-7.96	
FP11		FP	FP	1900	48.90	0.00	
FP12		FP	FP	1750	48.90	0.00	between Skimmer Surge Tanks

*: See footnotes in Table 6.2.3.4-1.

** : The spent fuel pool is normal condition



**Table 6.2.3.4-6 Thermal Loads for Shell Elements
LOCA: 6 min.: Summer (Continued)**

Location	Index	Boundary*		Thickness (mm)	Td (°C)	Tg (°C)	note
		1	2				
Outer Wall	BW1	RM	GR	2000	26.47	21.94	below Grade General
	BW4	RM	RM	2000	40.00	0.00	below Grade Stair Case
	BW5	FP	GR	2000	32.19	33.39	below Grade Spent Fuel Pool
	BW6	FP	GR	3600	32.20	33.39	
	GW1	RM	AT	1500	43.37	-5.14	EL 4650 ~ 27000 General
	GW2	RM	RM	1500	40.00	0.00	EL 4650 ~ 27000 Stair Case
	GW3	XP	AT	1000	44.83	-0.90	EL 27000 ~ IC/PCCS Pool
	GW5	DP	AT	3000	44.52	-3.04	
	GW6	DP	AT	3500	44.53	-3.06	
	GW7	XP	AT	1500	44.75	-1.54	
	GW8	XP	RM	1000	42.14	4.49	EL 27000 ~ Stair Case/Pool
	GW9	RM	AT	1000	43.49	-4.77	EL 27000 ~ Room
GW10	RM	RM	1000	40.00	0.00	EL 27000 ~ Stair Case	
GW11	DP	AT	1500	44.53	-3.05		
MS Tunnel	MT1	MT	RM	1300	48.50	12.51	Wall inside Building
	MT2	MT	AT	1300	50.91	8.97	Wall outside Building
	MT4	MT	RM	1600	48.50	13.16	Slab inside Building
	MT5	MT	DP	2400	49.38	12.76	
	MT6	XP	MT	2400	49.56	-11.69	
	MT7	MT	AT	1600	51.01	9.28	Slab outside Building
	MT8	MT	AT	2400	51.17	9.76	
	MT9	MT	RM	2400	48.50	14.23	
	Inner Wall	IW1	RM	RM	-	40.00	0.00
Slab	SL1	RM	RM	-	40.00	0.00	General
	SL2	IP	RM	1000	41.89	4.34	below & above IC/PCCS Pool
	SL3	XP	RM	1000	41.86	4.15	
	SL4	DP	RM	1000	41.78	2.43	
	SL5	RM	AT	1000	43.49	-4.77	RB Roof at EL 34000
	SL6	XP	AT	1000	44.83	-0.90	
	SL7	RM	AT	700	43.63	-4.36	RB Roof at EL 57400
	SL8	RM	AT	700	43.63	-4.36	FB Roof at EL 22500
RCCV Liner	CVL2				110.00	0.00	Suppression Pool
	CVL3				130.00	0.00	Wetwell Air Space
	CVL4				171.00	0.00	Drywell General
	CVL5				43.00	0.00	Drywell GDCS Pool
RPV Pedestal & Basemat Liner	RPL1				171.00	0.00	
	RPL2				145.00	0.00	at LOCA Flooding
MAT Liner	MTL1				46.02	0.00	Lower Drywell

*: See footnotes in Table 6.2.3.4-1.



**Table 6.2.3.4-7 Thermal Loads for Shell Elements
LOCA: 10 hr.: Summer**

Location	Index	Boundary*		Thickness (mm)	Td (°C)	Tg (°C)	note	
		1	2					
Basemat	BM1	RM	GR	4000	27.07	23.15	General	
	BM2	DW	GR	5100	27.47	23.94	below lower Drywell	
	BM4	DW	FL	5100	27.47	23.94	at LOCA Flooding	
	BM6	FP	GR	5500	32.20	33.40	below Spent Fuel Pool	
	BM7	FP	GR	4000	32.20	33.40	Skimmer Surge Tank	
RCCV Wall	CV1	RM	RM	2000	40.00	0.00	below Grade	
	CV2	SP	RM	2000	47.95	34.85	Suppression Pool	
	CV3	WW	RM	2000	48.87	40.09	Wetwell Air Space	
	CV4	DW	RM	2000	57.44	59.43	Drywell General	
	CV5	GP	RM	2000	47.85	34.44	Drywell GDCS Pool	
	CV6	DW	MT	2000	65.78	44.88	Drywell MS Tunnel	
Suppression Pool Slab	SP1	SP	RM	2000	47.94	34.81		
Top Slab	TS1	DW	DP	2400	56.81	51.83	below DSP/FP	
	TS2	DW	IP	2400	61.94	24.80	below IC/PCCS	
	TS3	DW	XP	2400	61.85	25.20	below Expansion Pool	
	TS4	DW	DP	2400	68.65	48.56	around Drywell Head	
	TS5	DW	RM	2400	55.93	53.28	below Room	
RPV Pedestal	RP1	DW	RM	2400	55.93	53.28		
	RP2	FL	RM	2400	55.52	51.16	at LOCA Flooding	
Pool Girder	PG1	IP	DP	1600	50.70	37.81		
	PG2	XP	DP	1600	50.57	37.30		
	PG3	DP	RM	1600	41.69	2.62		
Pool Gate Wall IC/PCCS Pool Wall Expansion Pool Wall	PW1	DP	DP	1300	43.00	0.00		
	PW2	IP	IP	400	100.11	0.00		
	PW4	IP	XP	600	83.87	0.33		
	PW6	XP	XP	1000	67.33	0.00		
	PW7	XP	XP	2000	55.10	0.00		
	PW8	XP	RM	1000	53.88	54.26		
	PW9	XP	RM	2000	47.69	33.72		
	PW10	RM	RM	1000	40.00	0.00		
	PW11	RM	RM	2000	40.00	0.00		
	PW12	IP	XP	1000	67.53	0.58		
	PW13	IP	RM	1000	54.15	55.02		
	PW14	IP	XP	470	93.68	0.12		
	Spent Fuel Pool Wall**	FP7	FP	RM	1500	45.05	7.70	
		FP8	FP	RM	1900	44.94	7.92	
FP9		FP	RM	1750	44.97	7.85	around Skimmer Surge Tank	
FP10		FP	RM	2000	44.91	-7.96		
FP11		FP	FP	1900	48.90	0.00		
FP12		FP	FP	1750	48.90	0.00	between Skimmer Surge Tanks	

*: See footnotes in Table 6.2.3.4-1.

** : The spent fuel pool is normal condition



**Table 6.2.3.4-7 Thermal Loads for Shell Elements
LOCA: 10 hr.: Summer (Continued)**

Location	Index	Boundary*		Thickness (mm)	Td (°C)	Tg (°C)	note
		1	2				
Outer Wall	BW1	RM	GR	2000	26.47	21.94	below Grade General
	BW4	RM	RM	2000	40.00	0.00	below Grade Stair Case
	BW5	FP	GR	2000	32.19	33.39	below Grade Spent Fuel Pool
	BW6	FP	GR	3600	32.20	33.39	
	GW1	RM	AT	1500	43.37	-5.14	EL 4650 ~ 27000 General
	GW2	RM	RM	1500	40.00	0.00	EL 4650 ~ 27000 Stair Case
	GW3	XP	AT	1000	56.57	48.87	EL 27000 ~ IC/PCCS Pool
	GW5	DP	AT	3000	44.52	-3.04	
	GW6	DP	AT	3500	44.53	-3.06	
	GW7	XP	AT	1500	52.55	36.10	
	GW8	XP	RM	1000	53.88	54.26	EL 27000 ~ Stair Case/Pool
	GW9	RM	AT	1000	43.49	-4.77	EL 27000 ~ Room
GW10	RM	RM	1000	40.00	0.00	EL 27000 ~ Stair Case	
GW11	DP	AT	1500	44.53	-3.05		
MS Tunnel	MT1	MT	RM	1300	48.50	12.51	Wall inside Building
	MT2	MT	AT	1300	50.91	8.97	Wall outside Building
	MT4	MT	RM	1600	48.50	13.16	Slab inside Building
	MT5	MT	DP	2400	49.38	12.76	
	MT6	XP	MT	2400	54.41	13.82	
	MT7	MT	AT	1600	51.01	9.28	Slab outside Building
	MT8	MT	AT	2400	51.17	9.76	
	MT9	MT	RM	2400	48.50	14.23	
Inner Wall	IW1	RM	RM	-	40.00	0.00	General
Slab	SL1	RM	RM	-	40.00	0.00	General
	SL2	IP	RM	1000	53.88	54.83	below & above IC/PCCS Pool
	SL3	XP	RM	1000	53.68	54.25	
	SL4	DP	RM	1000	41.78	2.43	
	SL5	RM	AT	1000	43.49	-4.77	RB Roof at EL 34000
	SL6	XP	AT	1000	56.57	48.87	
	SL7	RM	AT	700	43.63	-4.36	RB Roof at EL 57400
	SL8	RM	AT	700	43.63	-4.36	FB Roof at EL 22500
RCCV Liner	CVL2				110.00	0.00	Suppression Pool
	CVL3				121.00	0.00	Wetwell Air Space
	CVL4				150.00	0.00	Drywell General
	CVL5				110.00	0.00	Drywell GDCS Pool
RPV Pedestal & Basemat Liner	RPL1				150.00	0.00	
	RPL2				145.00	0.00	at LOCA Flooding
MAT Liner	MTL1				46.02	0.00	Lower Drywell

*: See footnotes in Table 6.2.3.4-1.



**Table 6.2.3.4-8 Thermal Loads for Shell Elements
LOCA: 72 hr.: Summer**

Location	Index	Boundary*		Thickness (mm)	Td (°C)	Tg (°C)	note	
		1	2					
Basemat	BM1	RM	GR	4000	27.07	23.15	General	
	BM2	DW	GR	5100	27.47	23.94	below lower Drywell	
	BM4	DW	FL	5100	27.47	23.94	at LOCA Flooding	
	BM6	FP	GR	5500	32.20	33.40	below Spent Fuel Pool	
	BM7	FP	GR	4000	32.20	33.40	Skimmer Surge Tank	
RCCV Wall	CV1	RM	RM	2000	40.00	0.00	below Grade	
	CV2	SP	RM	2000	58.58	63.97	Suppression Pool	
	CV3	WW	RM	2000	61.28	74.05	Wetwell Air Space	
	CV4	DW	RM	2000	72.43	100.39	Drywell General	
	CV5	GP	RM	2000	58.55	63.96	Drywell GDCS Pool	
	CV6	DW	MT	2000	80.52	85.14	Drywell MS Tunnel	
Suppression Pool Slab	SP1	SP	RM	2000	58.63	63.98		
Top Slab	TS1	DW	DP	2400	69.29	92.58	below DSP/FP	
	TS2	DW	IP	2400	83.38	35.98	below IC/PCCS	
	TS3	DW	XP	2400	83.35	36.04	below Expansion Pool	
	TS4	DW	DP	2400	91.96	79.99	around Drywell Head	
	TS5	DW	RM	2400	68.39	94.07	below Room	
RPV Pedestal	RP1	DW	RM	2400	68.39	94.07		
	RP2	FL	RM	2400	67.34	89.83	at LOCA Flooding	
Pool Girder	PG1	IP	DP	1600	63.99	65.12		
	PG2	XP	DP	1600	63.95	65.09		
	PG3	DP	RM	1600	41.69	2.62		
Pool Gate Wall	PW1	DP	DP	1300	43.00	0.00		
IC/PCCS Pool Wall	PW2	IP	IP	400	110.00	0.00		
Expansion Pool Wall	PW4	IP	XP	600	109.81	0.00		
	PW6	XP	XP	1000	102.60	0.00		
	PW7	XP	XP	2000	76.75	0.00		
	PW8	XP	RM	1000	73.42	63.26		
	PW9	XP	RM	2000	58.49	63.85		
	PW10	RM	RM	1000	40.00	0.00		
	PW11	RM	RM	2000	40.00	0.00		
	PW12	IP	XP	1000	102.63	0.00		
	PW13	IP	RM	1000	73.58	63.18		
	PW14	IP	XP	470	110.00	0.00		
	Spent Fuel Pool Wall**	FP7	FP	RM	1500	45.05	7.70	
		FP8	FP	RM	1900	44.94	7.92	
FP9		FP	RM	1750	44.97	7.85	around Skimmer Surge Tank	
FP10		FP	RM	2000	44.91	-7.96		
FP11		FP	FP	1900	48.90	0.00		
FP12		FP	FP	1750	48.90	0.00	between Skimmer Surge Tanks	

*: See footnotes in Table 6.2.3.4-1.

** : The spent fuel pool is normal condition



**Table 6.2.3.4-8 Thermal Loads for Shell Elements
LOCA: 72 hr.: Summer (Continued)**

Location	Index	Boundary*		Thickness (mm)	Td (°C)	Tg (°C)	note
		1	2				
Outer Wall	BW1	RM	GR	2000	26.47	21.94	below Grade General
	BW4	RM	RM	2000	40.00	0.00	below Grade Stair Case
	BW5	FP	GR	2000	32.19	33.39	below Grade Spent Fuel Pool
	BW6	FP	GR	3600	32.20	33.39	
	GW1	RM	AT	1500	43.37	-5.14	EL 4650 ~ 27000 General
	GW2	RM	RM	1500	40.00	0.00	EL 4650 ~ 27000 Stair Case
	GW3	XP	AT	1000	74.79	62.12	EL 27000 ~ IC/PCCS Pool
	GW5	DP	AT	3000	44.52	-3.04	
	GW6	DP	AT	3500	44.53	-3.06	
	GW7	XP	AT	1500	66.71	62.44	
	GW8	XP	RM	1000	73.42	63.26	EL 27000 ~ Stair Case/Pool
	GW9	RM	AT	1000	43.49	-4.77	EL 27000 ~ Room
GW10	RM	RM	1000	40.00	0.00	EL 27000 ~ Stair Case	
GW11	DP	AT	1500	44.53	-3.05		
MS Tunnel	MT1	MT	RM	1300	48.50	12.51	Wall inside Building
	MT2	MT	AT	1300	50.91	8.97	Wall outside Building
	MT4	MT	RM	1600	48.50	13.16	Slab inside Building
	MT5	MT	DP	2400	49.38	12.76	
	MT6	XP	MT	2400	63.41	43.71	
	MT7	MT	AT	1600	51.01	9.28	Slab outside Building
	MT8	MT	AT	2400	51.17	9.76	
	MT9	MT	RM	2400	48.50	14.23	
Inner Wall	IW1	RM	RM	-	40.00	0.00	General
Slab	SL1	RM	RM	-	40.00	0.00	General
	SL2	IP	RM	1000	73.41	63.28	below & above IC/PCCS Pool
	SL3	XP	RM	1000	73.36	63.31	
	SL4	DP	RM	1000	41.78	2.43	
	SL5	RM	AT	1000	43.49	-4.77	RB Roof at EL 34000
	SL6	XP	AT	1000	74.79	62.12	
	SL7	RM	AT	700	43.63	-4.36	RB Roof at EL 57400
	SL8	RM	AT	700	43.63	-4.36	FB Roof at EL 22500
RCCV Liner	CVL2				110.00	0.00	Suppression Pool
	CVL3				121.00	0.00	Wetwell Air Space
	CVL4				150.00	0.00	Drywell General
	CVL5				110.00	0.00	Drywell GDCS Pool
RPV Pedestal & Basemat Liner	RPL1				150.00	0.00	
	RPL2				145.00	0.00	at LOCA Flooding
MAT Liner	MTL1				47.08	0.00	Lower Drywell

*: See footnotes in Table 6.2.3.4-1.



**Table 6.2.3.4-9 Thermal Loads for Shell Elements
Normal Operation: winter**

Location	Index	Boundary*		Thickness (mm)	Td (°C)	Tg (°C)	note	
		1	2					
Basemat	BM1	RM	GR	4000	12.90	-5.20	General	
	BM2	DW	GR	5100	27.47	23.94	below lower Drywell	
	BM4	DW	FL	5100	-	-	at LOCA Flooding	
	BM6	FP	GR	5500	32.20	33.40	below Spent Fuel Pool	
	BM7	FP	GR	4000	32.20	33.40	Skimmer Surge Tank	
RCCV Wall	CV1	RM	RM	2000	10.00	0.00	below Grade	
	CV2	SP	RM	2000	28.22	29.53	Suppression Pool	
	CV3	WW	RM	2000	26.50	26.73	Wetwell Air Space	
	CV4	DW	RM	2000	33.50	38.08	Drywell General	
	CV5	GP	RM	2000	28.23	29.54	Drywell GDCS Pool	
	CV6	DW	MT	2000	57.00	0.00	Drywell MS Tunnel	
Suppression Pool Slab	SP1	SP	RM	2000	28.22	29.50		
Top Slab	TS1	DW	DP	2400	49.38	12.75	below DSP/FP	
	TS2	DW	IP	2400	49.38	12.75	below IC/PCCS	
	TS3	DW	XP	2400	49.38	12.75	below Expansion Pool	
	TS4	DW	DP	2400	50.81	12.61	around Drywell Head	
	TS5	DW	RM	2400	33.50	39.33	below Room	
RPV Pedestal	RP1	DW	RM	2400	33.50	39.33		
	RP2	FL	RM	2400	-	-	at LOCA Flooding	
Pool Girder	PG1	IP	DP	1600	43.00	0.00		
	PG2	XP	DP	1600	43.00	0.00		
	PG3	DP	RM	1600	28.60	28.80		
Pool Gate Wall IC/PCCS Pool Wall Expansion Pool Wall	PW1	DP	DP	1300	43.00	0.00		
	PW2	IP	IP	400	43.00	0.00		
	PW4	IP	XP	600	43.00	0.00		
	PW6	XP	XP	1000	43.00	0.00		
	PW7	XP	XP	2000	43.00	0.00		
	PW8	XP	RM	1000	29.63	26.71		
	PW9	XP	RM	2000	28.22	29.53		
	PW10	RM	RM	1000	10.00	0.00		
	PW11	RM	RM	2000	10.00	0.00		
	PW12	IP	XP	1000	43.00	0.00		
	PW13	IP	RM	1000	29.65	26.67		
	PW14	IP	XP	470	43.00	0.00		
	Spent Fuel Pool Wall**	FP7	FP	RM	1500	32.07	33.63	
		FP8	FP	RM	1900	31.58	34.62	
FP9		FP	RM	1750	31.74	34.30	around Skimmer Surge Tank	
FP10		FP	RM	2000	31.48	-34.82		
FP11		FP	FP	1900	48.90	0.00		
FP12		FP	FP	1750	48.90	0.00	between Skimmer Surge Tanks	

*: See footnotes in Table 6.2.3.4-1.

** : The spent fuel pool is normal condition



**Table 6.2.3.4-9 Thermal Loads for Shell Elements
Normal Operation: Winter (Continued)**

Location	Index	Boundary*		Thickness (mm)	Td (°C)	Tg (°C)	note
		1	2				
Outer Wall	BW1	RM	GR	2000	13.04	-4.93	below Grade General
	BW4	RM	RM	2000	10.00	0.00	below Grade Stair Case
	BW5	FP	GR	2000	32.19	33.39	below Grade Spent Fuel Pool
	BW6	FP	GR	3600	32.20	33.39	
	GW1	RM	AT	1500	-17.73	42.29	EL 4650 ~ 27000 General
	GW2	RM	RM	1500	10.00	0.00	EL 4650 ~ 27000 Stair Case
	GW3	XP	AT	1000	3.08	79.74	EL 27000 ~ IC/PCCS Pool
	GW5	DP	AT	3000	2.17	81.66	
	GW6	DP	AT	3500	1.97	82.06	
	GW7	XP	AT	1500	2.57	80.80	
	GW8	XP	RM	1000	29.63	26.71	EL 27000 ~ Stair Case/Pool
	GW9	RM	AT	1000	-18.80	39.27	EL 27000 ~ Room
GW10	RM	RM	1000	10.00	0.00	EL 27000 ~ Stair Case	
GW11	DP	AT	1500	2.58	80.84		
MS Tunnel	MT1	MT	RM	1300	33.50	34.58	Wall inside Building
	MT2	MT	AT	1300	2.54	80.15	Wall outside Building
	MT4	MT	RM	1600	33.50	36.39	Slab inside Building
	MT5	MT	DP	2400	49.38	12.76	
	MT6	XP	MT	2400	49.38	-12.75	
	MT7	MT	AT	1600	3.49	82.85	Slab outside Building
	MT8	MT	AT	2400	4.99	87.08	
	MT9	MT	RM	2400	33.50	39.30	
	Inner Wall	IW1	RM	RM	-	10.00	0.00
Slab	SL1	RM	RM	-	10.00	0.00	General
	SL2	IP	RM	1000	26.49	22.45	below & above IC/PCCS Pool
	SL3	XP	RM	1000	26.49	22.45	
	SL4	DP	RM	1000	29.62	26.76	
	SL5	RM	AT	1000	-18.80	39.27	RB Roof at EL 34000
	SL6	XP	AT	1000	3.08	79.74	
	SL7	RM	AT	700	-19.97	35.96	RB Roof at EL 57400
	SL8	RM	AT	700	-19.97	35.96	FB Roof at EL 22500
RCCV Liner	CVL2				43.00	0.00	Suppression Pool
	CVL3				43.00	0.00	Wetwell Air Space
	CVL4				57.00	0.00	Drywell General
	CVL5				43.00	0.00	Drywell GDCS Pool
RPV Pedestal & Basemat Liner	RPL1				57.00	0.00	
	RPL2				-	-	at LOCA Flooding
MAT Liner	MTL1				46.02	0.00	Lower Drywell

*: See footnotes in Table 6.2.3.4-1.



**Table 6.2.3.4-10 Thermal Loads for Shell Elements
LOCA: 5 sec.: Winter**

Location	Index	Boundary*		Thickness (mm)	Td (°C)	Tg (°C)	note
		1	2				
Basemat	BM1	RM	GR	4000	12.90	-5.20	General
	BM2	DW	GR	5100	27.47	23.94	below lower Drywell
	BM4	DW	FL	5100	27.47	23.94	at LOCA Flooding
	BM6	FP	GR	5500	32.20	33.40	below Spent Fuel Pool
	BM7	FP	GR	4000	32.20	33.40	Skimmer Surge Tank
RCCV Wall	CV1	RM	RM	2000	10.00	0.00	below Grade
	CV2	SP	RM	2000	28.22	29.53	Suppression Pool
	CV3	WW	RM	2000	26.61	27.42	Wetwell Air Space
	CV4	DW	RM	2000	33.85	40.18	Drywell General
	CV5	GP	RM	2000	28.23	29.54	Drywell GDCS Pool
	CV6	DW	MT	2000	57.33	1.97	Drywell MS Tunnel
Suppression Pool Slab	SP1	SP	RM	2000	28.22	29.50	
Top Slab	TS1	DW	DP	2400	49.72	14.76	below DSP/FP
	TS2	DW	IP	2400	49.72	14.76	below IC/PCCS
	TS3	DW	XP	2400	49.72	14.76	below Expansion Pool
	TS4	DW	DP	2400	51.23	15.08	around Drywell Head
	TS5	DW	RM	2400	33.85	41.41	below Room
RPV Pedestal	RP1	DW	RM	2400	33.85	41.41	
	RP2	FL	RM	2400	33.95	42.01	at LOCA Flooding
Pool Girder	PG1	IP	DP	1600	43.00	0.00	
	PG2	XP	DP	1600	43.00	0.00	
	PG3	DP	RM	1600	28.60	28.80	
Pool Gate Wall	PW1	DP	DP	1300	43.00	0.00	
IC/PCCS Pool Wall	PW2	IP	IP	400	43.00	0.00	
	PW4	IP	XP	600	43.00	0.00	
Expansion Pool Wall	PW6	XP	XP	1000	43.00	0.00	
	PW7	XP	XP	2000	43.00	0.00	
	PW8	XP	RM	1000	29.63	26.71	
	PW9	XP	RM	2000	28.22	29.53	
	PW10	RM	RM	1000	10.00	0.00	
	PW11	RM	RM	2000	10.00	0.00	
	PW12	IP	XP	1000	43.00	0.00	
	PW13	IP	RM	1000	29.65	26.67	
	PW14	IP	XP	470	43.00	0.00	
	Spent Fuel Pool Wall**	FP7	FP	RM	1500	32.07	33.63
FP8		FP	RM	1900	31.58	34.62	
FP9		FP	RM	1750	31.74	34.30	around Skimmer Surge Tank
FP10		FP	RM	2000	31.48	-34.82	
FP11		FP	FP	1900	48.90	0.00	
FP12		FP	FP	1750	48.90	0.00	between Skimmer Surge Tanks

*: See footnotes in Table 6.2.3.4-1.

** : The spent fuel pool is normal condition



**Table 6.2.3.4-10 Thermal Loads for Shell Elements
LOCA: 5 sec.: Winter (Continued)**

Location	Index	Boundary*		Thickness (mm)	Td (°C)	Tg (°C)	note
		1	2				
Outer Wall	BW1	RM	GR	2000	13.04	-4.93	below Grade General
	BW4	RM	RM	2000	10.00	0.00	below Grade Stair Case
	BW5	FP	GR	2000	32.19	33.39	below Grade Spent Fuel Pool
	BW6	FP	GR	3600	32.20	33.39	
	GW1	RM	AT	1500	-17.73	42.29	EL 4650 ~ 27000 General
	GW2	RM	RM	1500	10.00	0.00	EL 4650 ~ 27000 Stair Case
	GW3	XP	AT	1000	3.08	79.74	EL 27000 ~ IC/PCCS Pool
	GW5	DP	AT	3000	2.17	81.66	
	GW6	DP	AT	3500	1.97	82.06	
	GW7	XP	AT	1500	2.57	80.80	
	GW8	XP	RM	1000	29.63	26.71	EL 27000 ~ Stair Case/Pool
	GW9	RM	AT	1000	-18.80	39.27	EL 27000 ~ Room
GW10	RM	RM	1000	10.00	0.00	EL 27000 ~ Stair Case	
GW11	DP	AT	1500	2.58	80.84		
MS Tunnel	MT1	MT	RM	1300	33.50	34.58	Wall inside Building
	MT2	MT	AT	1300	2.54	80.15	Wall outside Building
	MT4	MT	RM	1600	33.50	36.39	Slab inside Building
	MT5	MT	DP	2400	49.38	12.76	
	MT6	XP	MT	2400	49.38	-12.75	
	MT7	MT	AT	1600	3.49	82.85	Slab outside Building
	MT8	MT	AT	2400	4.99	87.08	
	MT9	MT	RM	2400	33.50	39.30	
Inner Wall	IW1	RM	RM	-	10.00	0.00	General
Slab	SL1	RM	RM	-	10.00	0.00	General
	SL2	IP	RM	1000	26.51	22.55	below & above IC/PCCS Pool
	SL3	XP	RM	1000	26.51	22.55	
	SL4	DP	RM	1000	29.62	26.76	
	SL5	RM	AT	1000	-18.80	39.27	RB Roof at EL 34000
	SL6	XP	AT	1000	3.08	79.74	
	SL7	RM	AT	700	-19.97	35.96	RB Roof at EL 57400
	SL8	RM	AT	700	-19.97	35.96	FB Roof at EL 22500
RCCV Liner	CVL2				43.00	0.00	Suppression Pool
	CVL3				86.20	0.00	Wetwell Air Space
	CVL4				133.67	0.00	Drywell General
	CVL5				43.00	0.00	Drywell GDCS Pool
RPV Pedestal & Basement Liner	RPL1				133.67	0.00	
	RPL2				145.00	0.00	at LOCA Flooding
MAT Liner	MTL1				46.02	0.00	Lower Drywell

*: See footnotes in Table 6.2.3.4-1.



**Table 6.2.3.4-11 Thermal Loads for Shell Elements
LOCA: 6 min.: Winter**

Location	Index	Boundary*		Thickness (mm)	Td (°C)	Tg (°C)	note	
		1	2					
Basemat	BM1	RM	GR	4000	12.90	-5.20	General	
	BM2	DW	GR	5100	27.47	23.94	below lower Drywell	
	BM4	DW	FL	5100	27.47	23.94	at LOCA Flooding	
	BM6	FP	GR	5500	32.20	33.40	below Spent Fuel Pool	
	BM7	FP	GR	4000	32.20	33.40	Skimmer Surge Tank	
RCCV Wall	CV1	RM	RM	2000	10.00	0.00	below Grade	
	CV2	SP	RM	2000	28.77	32.74	Suppression Pool	
	CV3	VVW	RM	2000	27.38	31.96	Wetwell Air Space	
	CV4	DW	RM	2000	34.70	45.19	Drywell General	
	CV5	GP	RM	2000	28.23	29.54	Drywell GDCS Pool	
	CV6	DW	MT	2000	58.16	6.84	Drywell MS Tunnel	
Suppression Pool Slab	SP1	SP	RM	2000	28.70	32.35		
Top Slab	TS1	DW	DP	2400	50.40	18.79	below DSP/FP	
	TS2	DW	IP	2400	50.59	17.62	below IC/PCCS	
	TS3	DW	XP	2400	50.58	17.72	below Expansion Pool	
	TS4	DW	DP	2400	53.41	18.97	around Drywell Head	
	TS5	DW	RM	2400	34.54	45.48	below Room	
RPV Pedestal	RP1	DW	RM	2400	34.54	45.48		
	RP2	FL	RM	2400	34.31	44.14	at LOCA Flooding	
Pool Girder	PG1	IP	DP	1600	43.26	1.52		
	PG2	XP	DP	1600	43.24	1.40		
	PG3	DP	RM	1600	28.60	28.80		
Pool Gate Wall IC/PCCS Pool Wall Expansion Pool Wall	PW1	DP	DP	1300	43.00	0.00		
	PW2	IP	IP	400	44.89	0.00		
	PW4	IP	XP	600	44.21	0.30		
	PW6	XP	XP	1000	43.71	0.00		
	PW7	XP	XP	2000	43.40	0.00		
	PW8	XP	RM	1000	29.98	28.78		
	PW9	XP	RM	2000	28.42	30.72		
	PW10	RM	RM	1000	10.00	0.00		
	PW11	RM	RM	2000	10.00	0.00		
	PW12	IP	XP	1000	43.74	0.19		
	PW13	IP	RM	1000	30.04	28.93		
	PW14	IP	XP	470	44.54	0.38		
	Spent Fuel Pool Wall**	FP7	FP	RM	1500	32.07	33.63	
		FP8	FP	RM	1900	31.58	34.62	
FP9		FP	RM	1750	31.74	34.30	around Skimmer Surge Tank	
FP10		FP	RM	2000	31.48	-34.82		
FP11		FP	FP	1900	48.90	0.00		
FP12		FP	FP	1750	48.90	0.00	between Skimmer Surge Tanks	

*: See footnotes in Table 6.2.3.4-1.

** : The spent fuel pool is normal condition



**Table 6.2.3.4-11 Thermal Loads for Shell Elements
LOCA: 6 min.: Winter (Continued)**

Location	Index	Boundary*		Thickness (mm)	Td (°C)	Tg (°C)	note
		1	2				
Outer Wall	BW1	RM	GR	2000	13.04	-4.93	below Grade General
	BW4	RM	RM	2000	10.00	0.00	below Grade Stair Case
	BW5	FP	GR	2000	32.19	33.39	below Grade Spent Fuel Pool
	BW6	FP	GR	3600	32.20	33.39	
	GW1	RM	AT	1500	-17.73	42.29	EL 4650 ~ 27000 General
	GW2	RM	RM	1500	10.00	0.00	EL 4650 ~ 27000 Stair Case
	GW3	XP	AT	1000	3.43	81.80	EL 27000 ~ IC/PCCS Pool
	GW5	DP	AT	3000	2.17	81.66	
	GW6	DP	AT	3500	1.97	82.06	
	GW7	XP	AT	1500	2.81	82.27	
	GW8	XP	RM	1000	29.98	28.78	EL 27000 ~ Stair Case/Pool
	GW9	RM	AT	1000	-18.80	39.27	EL 27000 ~ Room
GW10	RM	RM	1000	10.00	0.00	EL 27000 ~ Stair Case	
GW11	DP	AT	1500	2.58	80.84		
MS Tunnel	MT1	MT	RM	1300	33.50	34.58	Wall inside Building
	MT2	MT	AT	1300	2.54	80.15	Wall outside Building
	MT4	MT	RM	1600	33.50	36.39	Slab inside Building
	MT5	MT	DP	2400	49.38	12.76	
	MT6	XP	MT	2400	49.56	-11.69	
	MT7	MT	AT	1600	3.49	82.85	Slab outside Building
	MT8	MT	AT	2400	4.99	87.08	
	MT9	MT	RM	2400	33.50	39.30	
Inner Wall	IW1	RM	RM	-	10.00	0.00	General
Slab	SL1	RM	RM	-	10.00	0.00	General
	SL2	IP	RM	1000	26.97	25.26	below & above IC/PCCS Pool
	SL3	XP	RM	1000	26.94	25.08	
	SL4	DP	RM	1000	29.62	26.76	
	SL5	RM	AT	1000	-18.80	39.27	RB Roof at EL 34000
	SL6	XP	AT	1000	3.43	81.80	
	SL7	RM	AT	700	-19.97	35.96	RB Roof at EL 57400
	SL8	RM	AT	700	-19.97	35.96	FB Roof at EL 22500
RCCV Liner	CVL2				110.00	0.00	Suppression Pool
	CVL3				130.00	0.00	Wetwell Air Space
	CVL4				171.00	0.00	Drywell General
	CVL5				43.00	0.00	Drywell GDCS Pool
RPV Pedestal & Basemat Liner	RPL1				171.00	0.00	
	RPL2				145.00	0.00	at LOCA Flooding
MAT Liner	MTL1				46.02	0.00	Lower Drywell

*: See footnotes in Table 6.2.3.4-1.



**Table 6.2.3.4-12 Thermal Loads for Shell Elements
LOCA: 10 hr.: Winter**

Location	Index	Boundary*		Thickness (mm)	Td (°C)	Tg (°C)	note	
		1	2					
Basemat	BM1	RM	GR	4000	12.90	-5.20	General	
	BM2	DW	GR	5100	27.47	23.94	below lower Drywell	
	BM4	DW	FL	5100	27.47	23.94	at LOCA Flooding	
	BM6	FP	GR	5500	32.20	33.40	below Spent Fuel Pool	
	BM7	FP	GR	4000	32.20	33.40	Skimmer Surge Tank	
RCCV Wall	CV1	RM	RM	2000	10.00	0.00	below Grade	
	CV2	SP	RM	2000	34.51	61.70	Suppression Pool	
	CV3	WW	RM	2000	34.13	65.76	Wetwell Air Space	
	CV4	DW	RM	2000	42.70	85.11	Drywell General	
	CV5	GP	RM	2000	34.42	61.30	Drywell GDCS Pool	
	CV6	DW	MT	2000	65.78	44.88	Drywell MS Tunnel	
Suppression Pool Slab	SP1	SP	RM	2000	34.51	61.63		
Top Slab	TS1	DW	DP	2400	56.81	51.83	below DSP/FP	
	TS2	DW	IP	2400	61.94	24.80	below IC/PCCS	
	TS3	DW	XP	2400	61.85	25.20	below Expansion Pool	
	TS4	DW	DP	2400	68.65	48.56	around Drywell Head	
	TS5	DW	RM	2400	41.12	79.39	below Room	
RPV Pedestal	RP1	DW	RM	2400	41.12	79.39		
	RP2	FL	RM	2400	40.71	77.28	at LOCA Flooding	
Pool Girder	PG1	IP	DP	1600	50.70	37.81		
	PG2	XP	DP	1600	50.57	37.30		
	PG3	DP	RM	1600	28.60	28.80		
Pool Gate Wall	PW1	DP	DP	1300	43.00	0.00		
IC/PCCS Pool Wall	PW2	IP	IP	400	100.11	0.00		
Expansion Pool Wall	PW4	IP	XP	600	83.87	0.33		
	PW6	XP	XP	1000	67.33	0.00		
	PW7	XP	XP	2000	55.10	0.00		
	PW8	XP	RM	1000	41.72	78.55		
	PW9	XP	RM	2000	34.25	60.57		
	PW10	RM	RM	1000	10.00	0.00		
	PW11	RM	RM	2000	10.00	0.00		
	PW12	IP	XP	1000	67.53	0.58		
	PW13	IP	RM	1000	42.01	79.27		
	PW14	IP	XP	470	93.68	0.12		
	Spent Fuel Pool Wall**	FP7	FP	RM	1500	32.07	33.63	
		FP8	FP	RM	1900	31.58	34.62	
FP9		FP	RM	1750	31.74	34.30	around Skimmer Surge Tank	
FP10		FP	RM	2000	31.48	-34.82		
FP11		FP	FP	1900	48.90	0.00		
FP12		FP	FP	1750	48.90	0.00	between Skimmer Surge Tanks	

*: See footnotes in Table 6.2.3.4-1.

** : The spent fuel pool is normal condition



**Table 6.2.3.4-12 Thermal Loads for Shell Elements
LOCA: 10 hr.: Winter (Continued)**

Location	Index	Boundary*		Thickness (mm)	Td (°C)	Tg (°C)	note
		1	2				
Outer Wall	BW1	RM	GR	2000	13.04	-4.93	below Grade General
	BW4	RM	RM	2000	10.00	0.00	below Grade Stair Case
	BW5	FP	GR	2000	32.19	33.39	below Grade Spent Fuel Pool
	BW6	FP	GR	3600	32.20	33.39	
	GW1	RM	AT	1500	-17.73	42.29	EL 4650 ~ 27000 General
	GW2	RM	RM	1500	10.00	0.00	EL 4650 ~ 27000 Stair Case
	GW3	XP	AT	1000	15.17	131.57	EL 27000 ~ IC/PCCS Pool
	GW5	DP	AT	3000	2.17	81.66	
	GW6	DP	AT	3500	1.97	82.06	
	GW7	XP	AT	1500	10.61	119.91	
	GW8	XP	RM	1000	41.72	78.55	EL 27000 ~ Stair Case/Pool
	GW9	RM	AT	1000	-18.80	39.27	EL 27000 ~ Room
GW10	RM	RM	1000	10.00	0.00	EL 27000 ~ Stair Case	
GW11	DP	AT	1500	2.58	80.84		
MS Tunnel	MT1	MT	RM	1300	33.50	34.58	Wall inside Building
	MT2	MT	AT	1300	2.54	80.15	Wall outside Building
	MT4	MT	RM	1600	33.50	36.39	Slab inside Building
	MT5	MT	DP	2400	49.38	12.76	
	MT6	XP	MT	2400	54.41	13.82	
	MT7	MT	AT	1600	3.49	82.85	Slab outside Building
	MT8	MT	AT	2400	4.99	87.08	
	MT9	MT	RM	2400	33.50	39.30	
Inner Wall	IW1	RM	RM	-	10.00	0.00	General
Slab	SL1	RM	RM	-	10.00	0.00	General
	SL2	IP	RM	1000	39.78	79.05	below & above IC/PCCS Pool
	SL3	XP	RM	1000	39.58	78.47	
	SL4	DP	RM	1000	29.62	26.76	
	SL5	RM	AT	1000	-18.80	39.27	RB Roof at EL 34000
	SL6	XP	AT	1000	15.17	131.57	
	SL7	RM	AT	700	-19.97	35.96	RB Roof at EL 57400
	SL8	RM	AT	700	-19.97	35.96	FB Roof at EL 22500
RCCV Liner	CVL2				110.00	0.00	Suppression Pool
	CVL3				121.00	0.00	Wetwell Air Space
	CVL4				150.00	0.00	Drywell General
	CVL5				110.00	0.00	Drywell GDCS Pool
RPV Pedestal & Basemat Liner	RPL1				150.00	0.00	
	RPL2				145.00	0.00	at LOCA Flooding
MAT Liner	MTL1				46.02	0.00	Lower Drywell

*: See footnotes in Table 6.2.3.4-1.



**Table 6.2.3.4-13 Thermal Loads for Shell Elements
LOCA: 72 hr.: Winter**

Location	Index	Boundary*		Thickness (mm)	Td (°C)	Tg (°C)	note	
		1	2					
Basemat	BM1	RM	GR	4000	12.90	-5.20	General	
	BM2	DW	GR	5100	27.47	23.94	below lower Drywell	
	BM4	DW	FL	5100	27.47	23.94	at LOCA Flooding	
	BM6	FP	GR	5500	32.20	33.40	below Spent Fuel Pool	
	BM7	FP	GR	4000	32.20	33.40	Skimmer Surge Tank	
RCCV Wall	CV1	RM	RM	2000	10.00	0.00	below Grade	
	CV2	SP	RM	2000	45.15	90.82	Suppression Pool	
	CV3	WW	RM	2000	47.00	100.95	Wetwell Air Space	
	CV4	DW	RM	2000	58.15	127.30	Drywell General	
	CV5	GP	RM	2000	45.12	90.82	Drywell GDCS Pool	
	CV6	DW	MT	2000	80.52	85.14	Drywell MS Tunnel	
Suppression Pool Slab	SP1	SP	RM	2000	45.20	90.80		
Top Slab	TS1	DW	DP	2400	69.29	92.58	below DSP/FP	
	TS2	DW	IP	2400	83.38	35.98	below IC/PCCS	
	TS3	DW	XP	2400	83.35	36.04	below Expansion Pool	
	TS4	DW	DP	2400	91.96	79.99	around Drywell Head	
	TS5	DW	RM	2400	53.91	121.24	below Room	
RPV Pedestal	RP1	DW	RM	2400	53.91	121.24		
	RP2	FL	RM	2400	52.85	117.00	at LOCA Flooding	
Pool Girder	PG1	IP	DP	1600	63.99	65.12		
	PG2	XP	DP	1600	63.95	65.09		
	PG3	DP	RM	1600	28.60	28.80		
Pool Gate Wall IC/PCCS Pool Wall Expansion Pool Wall	PW1	DP	DP	1300	43.00	0.00		
	PW2	IP	IP	400	110.00	0.00		
	PW4	IP	XP	600	109.81	0.00		
	PW6	XP	XP	1000	102.60	0.00		
	PW7	XP	XP	2000	76.75	0.00		
	PW8	XP	RM	1000	61.26	87.55		
	PW9	XP	RM	2000	45.06	90.70		
	PW10	RM	RM	1000	10.00	0.00		
	PW11	RM	RM	2000	10.00	0.00		
	PW12	IP	XP	1000	102.63	0.00		
	PW13	IP	RM	1000	61.44	87.42		
	PW14	IP	XP	470	110.00	0.00		
	Spent Fuel Pool Wall**	FP7	FP	RM	1500	32.07	33.63	
		FP8	FP	RM	1900	31.58	34.62	
FP9		FP	RM	1750	31.74	34.30	around Skimmer Surge Tank	
FP10		FP	RM	2000	31.48	-34.82		
FP11		FP	FP	1900	48.90	0.00		
FP12		FP	FP	1750	48.90	0.00	between Skimmer Surge Tanks	

*: See footnotes in Table 6.2.3.4-1.

** : The spent fuel pool is normal condition



**Table 6.2.3.4-13 Thermal Loads for Shell Elements
LOCA: 72 hr.: Winter (Continued)**

Location	Index	Boundary*		Thickness (mm)	Td (°C)	Tg (°C)	note
		1	2				
Outer Wall	BW1	RM	GR	2000	13.04	-4.93	below Grade General
	BW4	RM	RM	2000	10.00	0.00	below Grade Stair Case
	BW5	FP	GR	2000	32.19	33.39	below Grade Spent Fuel Pool
	BW6	FP	GR	3600	32.20	33.39	
	GW1	RM	AT	1500	-17.73	42.29	EL 4650 ~ 27000 General
	GW2	RM	RM	1500	10.00	0.00	EL 4650 ~ 27000 Stair Case
	GW3	XP	AT	1000	33.31	145.06	EL 27000 ~ IC/PCCS Pool
	GW5	DP	AT	3000	2.17	81.66	
	GW6	DP	AT	3500	1.97	82.06	
	GW7	XP	AT	1500	24.77	146.28	
	GW8	XP	RM	1000	61.26	87.55	EL 27000 ~ Stair Case/Pool
	GW9	RM	AT	1000	-18.80	39.27	EL 27000 ~ Room
GW10	RM	RM	1000	10.00	0.00	EL 27000 ~ Stair Case	
GW11	DP	AT	1500	2.58	80.84		
MS Tunnel	MT1	MT	RM	1300	33.50	34.58	Wall inside Building
	MT2	MT	AT	1300	2.54	80.15	Wall outside Building
	MT4	MT	RM	1600	33.50	36.39	Slab inside Building
	MT5	MT	DP	2400	49.38	12.76	
	MT6	XP	MT	2400	63.41	43.71	
	MT7	MT	AT	1600	3.49	82.85	Slab outside Building
	MT8	MT	AT	2400	4.99	87.08	
	MT9	MT	RM	2400	33.50	39.30	
Inner Wall	IW1	RM	RM	-	10.00	0.00	General
Slab	SL1	RM	RM	-	10.00	0.00	General
	SL2	IP	RM	1000	60.67	88.02	below & above IC/PCCS Pool
	SL3	XP	RM	1000	60.63	88.06	
	SL4	DP	RM	1000	29.62	26.76	
	SL5	RM	AT	1000	-18.80	39.27	RB Roof at EL 34000
	SL6	XP	AT	1000	33.31	145.06	
	SL7	RM	AT	700	-19.97	35.96	RB Roof at EL 57400
	SL8	RM	AT	700	-19.97	35.96	FB Roof at EL 22500
RCCV Liner	CVL2				110.00	0.00	Suppression Pool
	CVL3				121.00	0.00	Wetwell Air Space
	CVL4				150.00	0.00	Drywell General
	CVL5				110.00	0.00	Drywell GDCS Pool
RPV Pedestal & Basemat Liner	RPL1				150.00	0.00	
	RPL2				145.00	0.00	at LOCA Flooding
MAT Liner	MTL1				47.08	0.00	Lower Drywell

*: See footnotes in Table 6.2.3.4-1.



Table 6.2.3.4-14 Thermal Loads for Beam Elements

Column /Girder	Index	Boundary*1				Summer			Winter		
		x1	x2	y1	y2	Td (°C)	Tg'x ^{*2} (°C)	Tg'y ^{*2} (°C)	Td (°C)	Tg'x ^{*2} (°C)	Tg'y ^{*2} (°C)
Girder	CB1	RM	RM	RM	RM	40.00	0.00	0.00	10.00	0.00	0.00
Cloumn	CB1	RM	RM	RM	RM	40.00	0.00	0.00	10.00	0.00	0.00
	CB2	RM	RM	RM	AT	41.75	0.00	-3.18	-4.40	0.00	26.18
	CB3	RM	AT	RM	AT	43.49	-3.18	-3.18	-18.80	26.18	26.18
	CB4	RM	AT	RM	RM	41.75	-3.18	0.00	-4.40	26.18	0.00

*1: RM: Room AT: Outer Air

*2: Tg' means effective liner gradient.

$$Tg' = Tg/t$$

where Tg: Surface Temperature Difference
t: Thickness

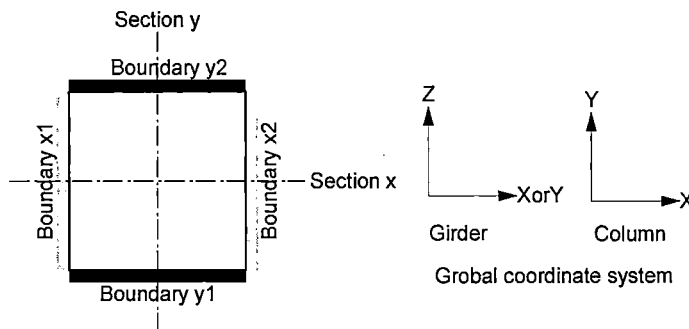


Table 6.2.3.4-15 Thermal Loads for Rod Elements of RCCV Top Head Opening at All Seasons

Event	Summer & Winter
	Td (°C)
Normal Operation	57.00
LOCA 5sec	133.67
LOCA 6min	171.00
LOCA 10hr	150.00
LOCA 72hr	150.00



Table 6.2.3.4-16 Design Thermal Load Labels

Load Label	Load Condition	Season	GDCS Condition	Spent Fuel Pool Condition	
	Event				
TLS0	Normal Operation	Summer	water height is 4.41m.	Normal Operation	
TLW0		Winter			
TLS1	LOCA5sec	Summer			
TLW1		Winter			
TLS2	LOCA6min	Summer			
TLW2		Winter			
TLS3	LOCA10hr	Summer			
TLW3		Winter			
TLS4	LOCA72hr	Summer			
TLW4		Winter			
TLS5	LOCA5sec	Summer			water height is 0.792 m.
TLW5		Winter			
TLS6	LOCA6min	Summer			
TLW6		Winter			
TLS7	LOCA10hr	Summer			
TLW7		Winter			
TLS8	LOCA72hr	Summer			
TLW8		Winter			
TFS5	LOCA5sec	Summer	LOCA Flooding water height is 0.792 m		
TFW5		Winter			
TFS6	LOCA6min	Summer			
TFW6		Winter			
TFS7	LOCA10hr	Summer			
TFW7		Winter			
TFS8	LOCA72hr	Summer			
TFW8		Winter			
TSS0	Normal Operation	Summer	water height is 0.792 m.	DBA 72hr	
TSW0		Winter			
TSS8	LOCA72hr	Summer			
TSW8		Winter			



**Table 6.2.3.4-17 Thermal Loads for Shell Elements around Spent Fuel Pool
72 hr. after DBA: Summer**

Location	Index	Boundary*		Thickness (mm)	Td (°C)	Tg (°C)	note
		1	2				
Basemat	BM6	FP	GR	5500	36.74	56.83	below Spent Fuel Pool
	BM7	FP	GR	4000	38.45	63.68	Skimmer Surge Tank
Spent Fuel Pool Wall**	FP7	FP	RM	1500	61.65	57.12	
	FP8	FP	RM	1900	58.10	54.97	
	FP9	FP	RM	1750	59.26	56.04	around Skimmer Surge Tank
	FP10	FP	RM	2000	57.42	-54.16	
	FP11	FP	FP	1900	75.29	0.00	
	FP12	FP	FP	1750	77.51	0.00	between Skimmer Surge Tanks
Outer Wall	BW5	FP	GR	2000	44.70	79.61	below Grade Spent Fuel Pool
	BW6	FP	GR	3600	39.14	66.16	

*: See footnotes in Table 6.2.3.4-1.

** : DBA for the spent fuel pool is due to loss of Fuel and Auxiliary Pools Cooling System (FAPCS) cooling function

**Table 6.2.3.4-18 Thermal Loads for Shell Elements around Spent Fuel Pool
72 hr. after DBA: Winter**

Location	Index	Boundary*		Thickness (mm)	Td (°C)	Tg (°C)	note
		1	2				
Basemat	BM6	FP	GR	5500	36.74	56.83	below Spent Fuel Pool
	BM7	FP	GR	4000	38.45	63.68	Skimmer Surge Tank
Spent Fuel Pool Wall**	FP7	FP	RM	1500	48.67	83.06	
	FP8	FP	RM	1900	44.74	81.67	
	FP9	FP	RM	1750	46.02	82.49	around Skimmer Surge Tank
	FP10	FP	RM	2000	43.99	-81.01	
	FP11	FP	FP	1900	75.29	0.00	
	FP12	FP	FP	1750	77.51	0.00	between Skimmer Surge Tanks
Outer Wall	BW5	FP	GR	2000	44.70	79.61	below Grade Spent Fuel Pool
	BW6	FP	GR	3600	39.14	66.16	

*: See footnotes in Table 6.2.3.4-1.

** : DBA for the spent fuel pool is due to loss of Fuel and Auxiliary Pools Cooling System (FAPCS) cooling function



**Table 6.2.3.4-19 Thermal Loads for Shell Elements
LOCA: 72 hr.: Winter (Case 1)**

Portion	Section*1	Side*2		Thick. t		Temperature (°C)		Thin Film Coef. (kcal/m ² h°C)		Surface Temp. (°C)		Linearized Temp. (°C)				
		1	2	(mm)	(m)	T1	T2	h1	h2	Ts1	Ts2	Td	Tg	Tg/t		
Floor Slab	E&W Side	SL1	RM	RM	-	-	10.0	10.0	6.0E+00	6.0E+00	10.00	10.00	10.00	0.0	0.00	
		SL4	RM	BP	2400	2.4	10.0	44.0	6.0E+00	1.0E+99	13.01	44.00	28.51	-31.0	-12.91	
		SL5	RM	AT	1000	1.0	10.0	-40.0	6.0E+00	3.5E+01	0.84	-38.43	-18.80	39.3	39.27	
	EAST Side	SL2E	IP	RM	1000	1.0	110.0	10.0	1.0E+99	6.0E+00	110.00	28.92	69.46	81.1	81.08	
		SL3E	RM	XI	1500	1.5	10.0	110.0	6.0E+00	1.0E+99	23.46	110.00	66.73	-86.5	-57.69	
		SL6E	XO	AT	1000	1.0	43.0	-40.0	1.0E+99	3.5E+01	43.00	-36.81	3.10	79.8	79.81	
		SL9E	RM	XO	1500	1.5	10.0	43.0	6.0E+00	1.0E+99	14.44	43.00	28.72	-28.6	-19.04	
		SL10E	RM	XS	1500	1.5	10.0	110.0	6.0E+00	1.0E+99	23.46	110.00	66.73	-86.5	-57.69	
		SL11E	XS	RM	1000	1.0	110.0	10.0	1.0E+99	6.0E+00	110.00	28.92	69.46	81.1	81.08	
		SL12E	PP	RM	1000	1.0	110.0	10.0	1.0E+99	6.0E+00	110.00	28.92	69.46	81.1	81.08	
		SL13E	XI	RM	1000	1.0	110.0	10.0	1.0E+99	6.0E+00	110.00	28.92	69.46	81.1	81.08	
		WEST Side	SL2W	IP	RM	1000	1.0	110.0	10.0	1.0E+99	6.0E+00	110.00	28.92	69.46	81.1	81.08
			SL3W	RM	XI	1500	1.5	10.0	110.0	6.0E+00	1.0E+99	23.46	110.00	66.73	-86.5	-57.69
	SL6W		XO	AT	1000	1.0	43.0	-40.0	1.0E+99	3.5E+01	43.00	-36.81	3.10	79.8	79.81	
	SL9W		RM	XO	1500	1.5	10.0	43.0	6.0E+00	1.0E+99	14.44	43.00	28.72	-28.6	-19.04	
	SL10W		RM	XS	1500	1.5	10.0	110.0	6.0E+00	1.0E+99	23.46	110.00	66.73	-86.5	-57.69	
	SL11W		XS	RM	1000	1.0	110.0	10.0	1.0E+99	6.0E+00	110.00	28.92	69.46	81.1	81.08	
	SL12W		PP	RM	1000	1.0	110.0	10.0	1.0E+99	6.0E+00	110.00	28.92	69.46	81.1	81.08	
	MS Tunnel	E&W Side	MT5	MT	DS	2400	2.4	57.0	110.0	1.0E+99	1.0E+99	57.00	110.00	83.50	-53.0	-22.08
	MT8		MT	AT	2400	2.4	57.0	-40.0	1.0E+99	3.5E+01	57.00	-38.41	9.30	95.4	39.75	
MT9	MT		RM	2400	2.4	57.0	10.0	1.0E+99	6.0E+00	57.00	14.16	35.58	42.8	17.85		
	EAST Side	MT6E	MT	XS	2400	2.4	57.0	110.0	1.0E+99	1.0E+99	57.00	110.00	83.50	-53.0	-22.08	
	WEST Side	MT6W	MT	XS	2400	2.4	57.0	110.0	1.0E+99	1.0E+99	57.00	110.00	83.50	-53.0	-22.08	
Top Slab	E&W Side	TS1	DW	DS	2400	2.4	150.0	110.0	6.0E+00	1.0E+99	146.46	110.00	128.23	36.5	15.19	
		TS4	DW	RW	2400	2.4	150.0	110.0	6.0E+00	1.0E+99	146.46	110.00	128.23	36.5	15.19	
		TS5	DW	RM	2400	2.4	150.0	10.0	6.0E+00	6.0E+00	138.60	21.40	80.00	117.2	48.84	
		TS7	DW	BP	2400	2.4	150.0	44.0	6.0E+00	1.0E+99	140.61	44.00	92.30	96.6	40.25	
	EAST Side	TS2E	DW	IP	2400	2.4	150.0	110.0	6.0E+00	1.0E+99	146.46	110.00	128.23	36.5	15.19	
		TS3E	DW	XI	2400	2.4	150.0	110.0	6.0E+00	1.0E+99	146.46	110.00	128.23	36.5	15.19	
		TS6E	DW	PP	2400	2.4	150.0	110.0	6.0E+00	1.0E+99	146.46	110.00	128.23	36.5	15.19	
	WEST Side	TS2W	DW	IP	2400	2.4	150.0	110.0	6.0E+00	1.0E+99	146.46	110.00	128.23	36.5	15.19	
		TS3W	DW	XI	2400	2.4	150.0	110.0	6.0E+00	1.0E+99	146.46	110.00	128.23	36.5	15.19	
		TS6W	DW	PP	2400	2.4	150.0	110.0	6.0E+00	1.0E+99	146.46	110.00	128.23	36.5	15.19	
Pool Girder	E&W Side	PG3	RM	DS	1600	1.6	10.0	110.0	6.0E+00	1.0E+99	22.73	110.00	66.36	-87.3	-54.55	
		PG7	RM	BP	1600	1.6	10.0	44.0	6.0E+00	1.0E+99	14.33	44.00	29.16	-29.7	-18.55	
	EAST Side	PG1E	PP	RW	1600	1.6	110.0	110.0	1.0E+99	1.0E+99	110.00	110.00	110.00	0.0	0.00	
		PG2E	XI	BP	1600	1.6	110.0	44.0	1.0E+99	1.0E+99	110.00	44.00	77.00	66.0	41.25	
		PG4E	IP	DS	1600	1.6	110.0	110.0	1.0E+99	1.0E+99	110.00	110.00	110.00	0.0	0.00	
		PG5E	PP	DS	1600	1.6	110.0	110.0	1.0E+99	1.0E+99	110.00	110.00	110.00	0.0	0.00	
		PG6E	IP	BP	1600	1.6	110.0	44.0	1.0E+99	1.0E+99	110.00	44.00	77.00	66.0	41.25	
		PG8E	XS	DS	1600	1.6	110.0	110.0	1.0E+99	1.0E+99	110.00	110.00	110.00	0.0	0.00	
		PG9E	PP	BP	1600	1.6	110.0	44.0	1.0E+99	1.0E+99	110.00	44.00	77.00	66.0	41.25	
		WEST Side	PG1W	PP	RW	1600	1.6	110.0	110.0	1.0E+99	1.0E+99	110.00	110.00	110.00	0.0	0.00
			PG2W	XI	BP	1600	1.6	110.0	44.0	1.0E+99	1.0E+99	110.00	44.00	77.00	66.0	41.25
	PG4W		IP	DS	1600	1.6	110.0	110.0	1.0E+99	1.0E+99	110.00	110.00	110.00	0.0	0.00	
	PG5W		PP	DS	1600	1.6	110.0	110.0	1.0E+99	1.0E+99	110.00	110.00	110.00	0.0	0.00	
	PG6W		IP	BP	1600	1.6	110.0	44.0	1.0E+99	1.0E+99	110.00	44.00	77.00	66.0	41.25	
	PG8W		XS	DS	1600	1.6	110.0	110.0	1.0E+99	1.0E+99	110.00	110.00	110.00	0.0	0.00	
		PG9W	PP	BP	1600	1.6	110.0	44.0	1.0E+99	1.0E+99	110.00	44.00	77.00	66.0	41.25	



**Table 6.2.3.4-19 Thermal Loads for Shell Elements
LOCA: 72 hr.: Winter (Case 1) Continued**

Portion	Section*1	Side*2		Thick. t		Temperature (°C)		Thin Film Coef. (kcal/m ² h°C)		Surface Temp. (°C)		Linearized Temp. (°C)			
		1	2	(mm)	(m)	T1	T2	h1	h2	Ts1	Ts2	Td	Tg	Tg/t	
External Wall	E&W Side	GW1	AT	RM	1500	1.5	-40.0	10.0	3.5E+01	6.0E+00	-38.87	3.42	-17.73	-42.3	-28.20
		GW5	AT	BP	2440	2.4	-40.0	44.0	3.5E+01	1.0E+99	-38.65	44.00	2.68	-82.6	-33.87
		GW6	DS	AT	3500	3.5	110.0	-40.0	1.0E+99	3.5E+01	110.00	-38.31	35.85	148.3	42.37
		GW9	AT	RM	1000	1.0	-40.0	10.0	3.5E+01	6.0E+00	-38.43	0.84	-18.80	-39.3	-39.27
		GW10	RM	RM	1000	1.0	10.0	10.0	6.0E+00	6.0E+00	10.00	10.00	10.00	0.0	0.00
		GW11	AT	BP	1500	1.5	-40.0	44.0	3.5E+01	1.0E+99	-37.82	44.00	3.09	-81.8	-54.55
	EAST Side	GW3E	AT	XO	1000	1.0	-40.0	43.0	3.5E+01	1.0E+99	-36.81	43.00	3.10	-79.8	-79.81
		GW7E	XS	AT	1500	1.5	110.0	-40.0	1.0E+99	3.5E+01	110.00	-36.10	36.95	146.1	97.40
		GW8E	RM	XO	1000	1.0	10.0	43.0	6.0E+00	1.0E+99	16.24	43.00	29.62	-26.8	-26.76
	WEST Side	GW3W	AT	XO	1000	1.0	-40.0	43.0	3.5E+01	1.0E+99	-36.81	43.00	3.10	-79.8	-79.81
		GW7W	XS	AT	1500	1.5	110.0	-40.0	1.0E+99	3.5E+01	110.00	-36.10	36.95	146.1	97.40
		GW8W	RM	XO	1000	1.0	10.0	43.0	6.0E+00	1.0E+99	16.24	43.00	29.62	-26.8	-26.76
Pool Wall	E&W Side	PW10	RM	RM	1000	1.0	10.0	10.0	6.0E+00	6.0E+00	10.00	10.00	10.00	0.0	0.00
		PW11	RM	RM	2000	2.0	10.0	10.0	6.0E+00	6.0E+00	10.00	10.00	10.00	0.0	0.00
		PW19	BP	RW	1300	1.3	44.0	110.0	1.0E+99	1.0E+99	44.00	110.00	77.00	-66.0	-50.77
	EAST Side	PW1E	RW	DS	1300	1.3	110.0	110.0	1.0E+99	1.0E+99	110.00	110.00	110.00	0.0	0.00
		PW2E	PP	PP	400	0.4	110.0	110.0	1.0E+99	1.0E+99	110.00	110.00	110.00	0.0	0.00
		PW4E	XI	PP	1000	1.0	110.0	110.0	1.0E+99	1.0E+99	110.00	110.00	110.00	0.0	0.00
		PW6E	XI	XS	1000	1.0	110.0	110.0	1.0E+99	1.0E+99	110.00	110.00	110.00	0.0	0.00
		PW7E	XO	XI	2000	2.0	43.0	110.0	1.0E+99	1.0E+99	43.00	110.00	76.50	-67.0	-33.50
		PW8E	XI	RM	1000	1.0	110.0	10.0	1.0E+99	6.0E+00	110.00	28.92	69.46	81.1	81.08
		PW9E	RM	XS	2000	2.0	10.0	110.0	6.0E+00	1.0E+99	20.45	110.00	65.22	-89.6	-44.78
		PW12E	IP	XI	1000	1.0	110.0	110.0	1.0E+99	1.0E+99	110.00	110.00	110.00	0.0	0.00
		PW13E	IP	RM	1000	1.0	110.0	10.0	1.0E+99	6.0E+00	110.00	28.92	69.46	81.1	81.08
		PW14E	XI	IP	470	0.5	110.0	110.0	1.0E+99	1.0E+99	110.00	110.00	110.00	0.0	0.00
		PW15E	XI	IP	1000	1.0	110.0	110.0	1.0E+99	1.0E+99	110.00	110.00	110.00	0.0	0.00
		PW16E	PP	IP	400	0.4	110.0	110.0	1.0E+99	1.0E+99	110.00	110.00	110.00	0.0	0.00
		PW17E	XO	RM	1000	1.0	43.0	10.0	1.0E+99	6.0E+00	43.00	16.24	29.62	26.8	26.76
		PW18E	RM	XS	1000	1.0	10.0	110.0	6.0E+00	1.0E+99	28.92	110.00	69.46	-81.1	-81.08
		WEST Side	PW1W	RW	DS	1300	1.3	110.0	110.0	1.0E+99	1.0E+99	110.00	110.00	110.00	0.0
	PW2W		PP	PP	400	0.4	110.0	110.0	1.0E+99	1.0E+99	110.00	110.00	110.00	0.0	0.00
	PW4W		XI	PP	1000	1.0	110.0	110.0	1.0E+99	1.0E+99	110.00	110.00	110.00	0.0	0.00
	PW6W		XI	XS	1000	1.0	110.0	110.0	1.0E+99	1.0E+99	110.00	110.00	110.00	0.0	0.00
	PW7W		XO	XI	2000	2.0	43.0	110.0	1.0E+99	1.0E+99	43.00	110.00	76.50	-67.0	-33.50
	PW8W		XI	RM	1000	1.0	110.0	10.0	1.0E+99	6.0E+00	110.00	28.92	69.46	81.1	81.08
	PW9W		RM	XS	2000	2.0	10.0	110.0	6.0E+00	1.0E+99	20.45	110.00	65.22	-89.6	-44.78
	PW12W		IP	XI	1000	1.0	110.0	110.0	1.0E+99	1.0E+99	110.00	110.00	110.00	0.0	0.00
	PW13W		IP	RM	1000	1.0	110.0	10.0	1.0E+99	6.0E+00	110.00	28.92	69.46	81.1	81.08
	PW14W		XI	IP	470	0.5	110.0	110.0	1.0E+99	1.0E+99	110.00	110.00	110.00	0.0	0.00
	PW15W		XI	IP	1000	1.0	110.0	110.0	1.0E+99	1.0E+99	110.00	110.00	110.00	0.0	0.00
	PW16W		PP	IP	400	0.4	110.0	110.0	1.0E+99	1.0E+99	110.00	110.00	110.00	0.0	0.00
	PW17W		XO	RM	1000	1.0	43.0	10.0	1.0E+99	6.0E+00	43.00	16.24	29.62	26.8	26.76
PW18W	RM		XS	1000	1.0	10.0	110.0	6.0E+00	1.0E+99	28.92	110.00	69.46	-81.1	-81.08	

*1: Refer to Figures E 3-1 and E 3-2 in Reference 2.1.2-e.

*2: Side

DW: Drywell	WW: Wetwell	SP: Suppression Pool
GP: GDCCS Pool	IP: IC Pool	PP: PCCS Pool
XI: Inner Expansion Pool	XO: Outer Expansion Pool	XS: Side Expansion Pool
RM: Room	DS: Equipment Storage Pool	BP: Buffer Pool
RW: Reactor Well	FP: Spent Fuel Pool	MT: MS Tunnel
GR: Ground	AT: Outside Air	

**Table 6.2.3.4-20 Thermal Loads for Shell Elements
LOCA: 72 hr.: Winter (Case 2)**

Portion	Section ^{*1}	Side ^{*2}		Thick. t		Temperature (°C)		Thin Film Coef. (kcal/m ² h°C)		Surface Temp. (°C)		Linearized Temp. (°C)			
		1	2	(mm)	(m)	T1	T2	h1	h2	Ts1	Ts2	Td	Tg	Tg/t	
Floor Slab	E&W Side	SL1	RM	RM	-	-	10.0	10.0	6.0E+00	6.0E+00	10.00	10.00	10.00	0.0	0.00
		SL4	RM	BP	2400	2.4	10.0	0.0	6.0E+00	1.0E+99	9.11	0.00	4.56	9.1	3.80
		SL5	RM	AT	1000	1.0	10.0	-40.0	6.0E+00	3.5E+01	0.84	-38.43	-18.80	39.3	39.27
	EAST Side	SL2E	IP	RM	1000	1.0	60.0	10.0	1.0E+99	6.0E+00	60.00	19.46	39.73	40.5	40.54
		SL3E	RM	XI	1500	1.5	10.0	0.0	6.0E+00	1.0E+99	8.65	0.00	4.33	8.7	5.77
		SL6E	XO	AT	1000	1.0	0.0	-40.0	1.0E+99	3.5E+01	0.00	-38.46	-19.23	38.5	38.46
		SL9E	RM	XO	1500	1.5	10.0	0.0	6.0E+00	1.0E+99	8.65	0.00	4.33	8.7	5.77
		SL10E	RM	XS	1500	1.5	10.0	0.0	6.0E+00	1.0E+99	8.65	0.00	4.33	8.7	5.77
		SL11E	XS	RM	1000	1.0	0.0	10.0	1.0E+99	6.0E+00	0.00	8.11	4.05	-8.1	-8.11
		SL12E	PP	RM	1000	1.0	100.0	10.0	1.0E+99	6.0E+00	100.00	27.03	63.51	73.0	72.97
		SL13E	XI	RM	1000	1.0	0.0	10.0	1.0E+99	6.0E+00	0.00	8.11	4.05	-8.1	-8.11
		WEST Side	SL2W	IP	RM	1000	1.0	60.0	10.0	1.0E+99	6.0E+00	60.00	19.46	39.73	40.5
	SL3W		RM	XI	1500	1.5	10.0	0.0	6.0E+00	1.0E+99	8.65	0.00	4.33	8.7	5.77
	SL6W		XO	AT	1000	1.0	0.0	-40.0	1.0E+99	3.5E+01	0.00	-38.46	-19.23	38.5	38.46
	SL9W		RM	XO	1500	1.5	10.0	0.0	6.0E+00	1.0E+99	8.65	0.00	4.33	8.7	5.77
	SL10W		RM	XS	1500	1.5	10.0	0.0	6.0E+00	1.0E+99	8.65	0.00	4.33	8.7	5.77
	SL11W		XS	RM	1000	1.0	0.0	10.0	1.0E+99	6.0E+00	0.00	8.11	4.05	-8.1	-8.11
	SL12W		PP	RM	1000	1.0	100.0	10.0	1.0E+99	6.0E+00	100.00	27.03	63.51	73.0	72.97
SL13W	XI		RM	1000	1.0	0.0	10.0	1.0E+99	6.0E+00	0.00	8.11	4.05	-8.1	-8.11	
MS Tunnel Slab	E&W Side		MT5	MT	DS	2400	2.4	57.0	100.0	1.0E+99	1.0E+99	57.00	100.00	78.50	-43.0
		MT8	MT	AT	2400	2.4	57.0	-40.0	1.0E+99	3.5E+01	57.00	-38.41	9.30	95.4	39.75
		MT9	MT	RM	2400	2.4	57.0	10.0	1.0E+99	6.0E+00	57.00	14.16	35.58	42.8	17.85
	EAST Side	MT6E	MT	XS	2400	2.4	57.0	0.0	1.0E+99	1.0E+99	57.00	0.00	28.50	57.0	23.75
	WEST Side	MT6W	MT	XS	2400	2.4	57.0	0.0	1.0E+99	1.0E+99	57.00	0.00	28.50	57.0	23.75
Top Slab	E&W Side	TS1	DW	DS	2400	2.4	150.0	100.0	6.0E+00	1.0E+99	145.57	100.00	122.78	45.6	18.99
		TS4	DW	RW	2400	2.4	150.0	100.0	6.0E+00	1.0E+99	145.57	100.00	122.78	45.6	18.99
		TS5	DW	RM	2400	2.4	150.0	10.0	6.0E+00	6.0E+00	138.60	21.40	80.00	117.2	48.84
		TS7	DW	BP	2400	2.4	150.0	0.0	6.0E+00	1.0E+99	136.71	0.00	68.35	136.7	56.96
	EAST Side	TS2E	DW	IP	2400	2.4	150.0	60.0	6.0E+00	1.0E+99	142.03	60.00	101.01	82.0	34.18
		TS3E	DW	XI	2400	2.4	150.0	0.0	6.0E+00	1.0E+99	136.71	0.00	68.35	136.7	56.96
		TS6E	DW	PP	2400	2.4	150.0	100.0	6.0E+00	1.0E+99	145.57	100.00	122.78	45.6	18.99
	WEST Side	TS2W	DW	IP	2400	2.4	150.0	60.0	6.0E+00	1.0E+99	142.03	60.00	101.01	82.0	34.18
		TS3W	DW	XI	2400	2.4	150.0	0.0	6.0E+00	1.0E+99	136.71	0.00	68.35	136.7	56.96
		TS6W	DW	PP	2400	2.4	150.0	100.0	6.0E+00	1.0E+99	145.57	100.00	122.78	45.6	18.99
Pool Girder	E&W Side	PG3	RM	DS	1600	1.6	10.0	100.0	6.0E+00	1.0E+99	21.45	100.00	60.73	-78.5	-49.09
		PG7	RM	BP	1600	1.6	10.0	0.0	6.0E+00	1.0E+99	8.73	0.00	4.36	8.7	5.45
	EAST Side	PG1E	PP	RW	1600	1.6	100.0	100.0	1.0E+99	1.0E+99	100.00	100.00	100.00	0.0	0.00
		PG2E	XI	BP	1600	1.6	0.0	0.0	1.0E+99	1.0E+99	0.00	0.00	0.00	0.0	0.00
		PG4E	IP	DS	1600	1.6	60.0	100.0	1.0E+99	1.0E+99	60.00	100.00	80.00	-40.0	-25.00
		PG5E	PP	DS	1600	1.6	100.0	100.0	1.0E+99	1.0E+99	100.00	100.00	100.00	0.0	0.00
		PG6E	IP	BP	1600	1.6	60.0	0.0	1.0E+99	1.0E+99	60.00	0.00	30.00	60.0	37.50
		PG8E	XS	DS	1600	1.6	0.0	100.0	1.0E+99	1.0E+99	0.00	100.00	50.00	-100.0	-62.50
		PG9E	PP	BP	1600	1.6	100.0	0.0	1.0E+99	1.0E+99	100.00	0.00	50.00	100.0	62.50
		WEST Side	PG1W	PP	RW	1600	1.6	100.0	100.0	1.0E+99	1.0E+99	100.00	100.00	100.00	0.0
	PG2W		XI	BP	1600	1.6	0.0	0.0	1.0E+99	1.0E+99	0.00	0.00	0.00	0.0	0.00
	PG4W		IP	DS	1600	1.6	60.0	100.0	1.0E+99	1.0E+99	60.00	100.00	80.00	-40.0	-25.00
	PG5W		PP	DS	1600	1.6	100.0	100.0	1.0E+99	1.0E+99	100.00	100.00	100.00	0.0	0.00
	PG6W		IP	BP	1600	1.6	60.0	0.0	1.0E+99	1.0E+99	60.00	0.00	30.00	60.0	37.50
	PG8W		XS	DS	1600	1.6	0.0	100.0	1.0E+99	1.0E+99	0.00	100.00	50.00	-100.0	-62.50
PG9W	PP		BP	1600	1.6	100.0	0.0	1.0E+99	1.0E+99	100.00	0.00	50.00	100.0	62.50	



**Table 6.2.3.4-20 Thermal Loads for Shell Elements
LOCA: 72 hr.: Winter (Case 2) Continued**

Portion	Section ^{*1}	Side ^{*2}		Thick.		Temperature		Thin Film Coef.		Surface Temp.		Linearized Temp.				
		1	2	(mm)	(m)	T1	T2	h1	h2	Ts1	Ts2	Td	Tg	Tg/t		
External Wall	E&W Side	GW1	AT	RM	1500	1.5	-40.0	10.0	3.5E+01	6.0E+00	-38.87	3.42	-17.73	-42.3	-28.20	
		GW5	AT	BP	2440	2.4	-40.0	0.0	3.5E+01	1.0E+99	-39.35	0.00	-19.68	-39.4	-16.13	
		GW6	DS	AT	3500	3.5	100.0	-40.0	1.0E+99	3.5E+01	100.00	-38.42	30.79	138.4	39.55	
		GW9	AT	RM	1000	1.0	-40.0	10.0	3.5E+01	6.0E+00	-38.43	0.84	-18.80	-39.3	-39.27	
		GW10	RM	RM	1000	1.0	10.0	10.0	6.0E+00	6.0E+00	10.00	10.00	10.00	0.0	0.00	
		GW11	AT	BP	1500	1.5	-40.0	0.0	3.5E+01	1.0E+99	-38.96	0.00	-19.48	-39.0	-25.97	
	EAST Side	GW3E	AT	XO	1000	1.0	-40.0	0.0	3.5E+01	1.0E+99	-38.46	0.00	-19.23	-38.5	-38.46	
		GW7E	XS	AT	1500	1.5	0.0	-40.0	1.0E+99	3.5E+01	0.00	-38.96	-19.48	39.0	25.97	
		GW8E	RM	XO	1000	1.0	10.0	0.0	6.0E+00	1.0E+99	8.11	0.00	4.05	8.1	8.11	
		WEST Side	GW3W	AT	XO	1000	1.0	-40.0	0.0	3.5E+01	1.0E+99	-38.46	0.00	-19.23	-38.5	-38.46
			GW7W	XS	AT	1500	1.5	0.0	-40.0	1.0E+99	3.5E+01	0.00	-38.96	-19.48	39.0	25.97
			GW8W	RM	XO	1000	1.0	10.0	0.0	6.0E+00	1.0E+99	8.11	0.00	4.05	8.1	8.11
Pool Wall	E&W Side	PW10	RM	RM	1000	1.0	10.0	10.0	6.0E+00	6.0E+00	10.00	10.00	10.00	0.0	0.00	
		PW11	RM	RM	2000	2.0	10.0	10.0	6.0E+00	6.0E+00	10.00	10.00	10.00	0.0	0.00	
		PW19	BP	RW	1300	1.3	0.0	100.0	1.0E+99	1.0E+99	0.00	100.00	50.00	-100.0	-76.92	
	EAST Side	PW1E	RW	DS	1300	1.3	100.0	100.0	1.0E+99	1.0E+99	100.00	100.00	100.00	0.0	0.00	
		PW2E	PP	PP	400	0.4	100.0	100.0	1.0E+99	1.0E+99	100.00	100.00	100.00	0.0	0.00	
		PW4E	XI	PP	1000	1.0	0.0	100.0	1.0E+99	1.0E+99	0.00	100.00	50.00	-100.0	-100.00	
		PW6E	XI	XS	1000	1.0	0.0	0.0	1.0E+99	1.0E+99	0.00	0.00	0.00	0.0	0.00	
		PW7E	XO	XI	2000	2.0	0.0	0.0	1.0E+99	1.0E+99	0.00	0.00	0.00	0.0	0.00	
		PW8E	XI	RM	1000	1.0	0.0	10.0	1.0E+99	6.0E+00	0.00	8.11	4.05	-8.1	-8.11	
		PW9E	RM	XS	2000	2.0	10.0	0.0	6.0E+00	1.0E+99	8.96	0.00	4.48	9.0	4.48	
		PW12E	IP	XI	1000	1.0	60.0	0.0	1.0E+99	1.0E+99	60.00	0.00	30.00	60.0	60.00	
		PW13E	IP	RM	1000	1.0	60.0	10.0	1.0E+99	6.0E+00	60.00	19.46	39.73	40.5	40.54	
		PW14E	XI	IP	470	0.5	0.0	60.0	1.0E+99	1.0E+99	0.00	60.00	30.00	-60.0	-127.66	
		PW15E	XI	IP	1000	1.0	0.0	60.0	1.0E+99	1.0E+99	0.00	60.00	30.00	-60.0	-60.00	
		PW16E	PP	IP	400	0.4	100.0	60.0	1.0E+99	1.0E+99	100.00	60.00	80.00	40.0	100.00	
		PW17E	XO	RM	1000	1.0	0.0	10.0	1.0E+99	6.0E+00	0.00	8.11	4.05	-8.1	-8.11	
		PW18E	RM	XS	1000	1.0	10.0	0.0	6.0E+00	1.0E+99	8.11	0.00	4.05	8.1	8.11	
		WEST Side	PW1W	RW	DS	1300	1.3	100.0	100.0	1.0E+99	1.0E+99	100.00	100.00	100.00	0.0	0.00
			PW2W	PP	PP	400	0.4	100.0	100.0	1.0E+99	1.0E+99	100.00	100.00	100.00	0.0	0.00
			PW4W	XI	PP	1000	1.0	0.0	100.0	1.0E+99	1.0E+99	0.00	100.00	50.00	-100.0	-100.00
	PW6W		XI	XS	1000	1.0	0.0	0.0	1.0E+99	1.0E+99	0.00	0.00	0.00	0.0	0.00	
	PW7W		XO	XI	2000	2.0	0.0	0.0	1.0E+99	1.0E+99	0.00	0.00	0.00	0.0	0.00	
	PW8W		XI	RM	1000	1.0	0.0	10.0	1.0E+99	6.0E+00	0.00	8.11	4.05	-8.1	-8.11	
	PW9W		RM	XS	2000	2.0	10.0	0.0	6.0E+00	1.0E+99	8.96	0.00	4.48	9.0	4.48	
	PW12W		IP	XI	1000	1.0	60.0	0.0	1.0E+99	1.0E+99	60.00	0.00	30.00	60.0	60.00	
	PW13W		IP	RM	1000	1.0	60.0	10.0	1.0E+99	6.0E+00	60.00	19.46	39.73	40.5	40.54	
	PW14W		XI	IP	470	0.5	0.0	60.0	1.0E+99	1.0E+99	0.00	60.00	30.00	-60.0	-127.66	
	PW15W		XI	IP	1000	1.0	0.0	60.0	1.0E+99	1.0E+99	0.00	60.00	30.00	-60.0	-60.00	
	PW16W		PP	IP	400	0.4	100.0	60.0	1.0E+99	1.0E+99	100.00	60.00	80.00	40.0	100.00	
	PW17W		XO	RM	1000	1.0	0.0	10.0	1.0E+99	6.0E+00	0.00	8.11	4.05	-8.1	-8.11	
PW18W	RM	XS	1000	1.0	10.0	0.0	6.0E+00	1.0E+99	8.11	0.00	4.05	8.1	8.11			

*1: Refer to Figures E 3-1 and E 3-2 in Reference 2.1.2-e.

*2: Side

- | | | |
|--------------------------|----------------------------|-------------------------|
| DW: Drywell | WW: Wetwell | SP: Suppression Pool |
| GP: GDCS Pool | IP: IC Pool | PP: PCCS Pool |
| XI: Inner Expansion Pool | XO: Outer Expansion Pool | XS: Side Expansion Pool |
| RM: Room | DS: Equipment Storage Pool | BP: Buffer Pool |
| RW: Reactor Well | FP: Spent Fuel Pool | MT: MS Tunnel |
| GR: Ground | AT: Outside Air | |



**Table 6.2.3.4-21 Thermal Loads for Shell Elements
LOCA: 72 hr.: Winter (Case 3)**

Portion	Section ^{*1}	Side ^{*2}		Thick. t		Temperature (°C)		Thin Film Coef. (kcal/m ² h°C)		Surface Temp. (°C)		Linearized Temp. (°C)				
		1	2	(mm)	(m)	T1	T2	h1	h2	Ts1	Ts2	Td	Tg	Tg/t		
Floor Slab	E&W Side	SL1	RM	RM	-	-	10.0	10.0	6.0E+00	6.0E+00	10.00	10.00	10.00	0.0	0.00	
		SL4	RM	BP	2400	2.4	10.0	0.0	6.0E+00	1.0E+99	9.11	0.00	4.56	9.1	3.80	
		SL5	RM	AT	1000	1.0	10.0	-40.0	6.0E+00	3.5E+01	0.84	-38.43	-18.80	39.3	39.27	
	EAST Side	SL2E	IP	RM	1000	1.0	60.0	10.0	1.0E+99	6.0E+00	60.00	19.46	39.73	40.5	40.54	
		SL3E	RM	XI	1500	1.5	10.0	110.0	6.0E+00	1.0E+99	23.46	110.00	66.73	-86.5	-57.69	
		SL6E	XO	AT	1000	1.0	0.0	-40.0	1.0E+99	3.5E+01	0.00	-38.46	-19.23	38.5	38.46	
		SL9E	RM	XO	1500	1.5	10.0	0.0	6.0E+00	1.0E+99	8.65	0.00	4.33	8.7	5.77	
		SL10E	RM	XS	1500	1.5	10.0	0.0	6.0E+00	1.0E+99	8.65	0.00	4.33	8.7	5.77	
		SL11E	XS	RM	1000	1.0	0.0	10.0	1.0E+99	6.0E+00	0.00	8.11	4.05	-8.1	-8.11	
		SL12E	PP	RM	1000	1.0	100.0	10.0	1.0E+99	6.0E+00	100.00	27.03	63.51	73.0	72.97	
		SL13E	XI	RM	1000	1.0	110.0	10.0	1.0E+99	6.0E+00	110.00	28.92	69.46	81.1	81.08	
		WEST Side	SL2W	IP	RM	1000	1.0	60.0	10.0	1.0E+99	6.0E+00	60.00	19.46	39.73	40.5	40.54
	SL3W		RM	XI	1500	1.5	10.0	110.0	6.0E+00	1.0E+99	23.46	110.00	66.73	-86.5	-57.69	
	SL6W		XO	AT	1000	1.0	0.0	-40.0	1.0E+99	3.5E+01	0.00	-38.46	-19.23	38.5	38.46	
	SL9W		RM	XO	1500	1.5	10.0	0.0	6.0E+00	1.0E+99	8.65	0.00	4.33	8.7	5.77	
	SL10W		RM	XS	1500	1.5	10.0	0.0	6.0E+00	1.0E+99	8.65	0.00	4.33	8.7	5.77	
	SL11W		XS	RM	1000	1.0	0.0	10.0	1.0E+99	6.0E+00	0.00	8.11	4.05	-8.1	-8.11	
	SL12W		PP	RM	1000	1.0	100.0	10.0	1.0E+99	6.0E+00	100.00	27.03	63.51	73.0	72.97	
SL13W	XI		RM	1000	1.0	110.0	10.0	1.0E+99	6.0E+00	110.00	28.92	69.46	81.1	81.08		
MS Tunnel	E&W Side		MT5	MT	DS	2400	2.4	57.0	110.0	1.0E+99	1.0E+99	57.00	110.00	83.50	-53.0	-22.08
		MT8	MT	AT	2400	2.4	57.0	-40.0	1.0E+99	3.5E+01	57.00	-38.41	9.30	95.4	39.75	
		MT9	MT	RM	2400	2.4	57.0	10.0	1.0E+99	6.0E+00	57.00	14.16	35.58	42.8	17.85	
	EAST Side	MT6E	MT	XS	2400	2.4	57.0	0.0	1.0E+99	1.0E+99	57.00	0.00	28.50	57.0	23.75	
	WEST Side	MT6W	MT	XS	2400	2.4	57.0	0.0	1.0E+99	1.0E+99	57.00	0.00	28.50	57.0	23.75	
Top Slab	E&W Side	TS1	DW	DS	2400	2.4	150.0	110.0	6.0E+00	1.0E+99	146.46	110.00	128.23	36.5	15.19	
		TS4	DW	RW	2400	2.4	150.0	110.0	6.0E+00	1.0E+99	146.46	110.00	128.23	36.5	15.19	
		TS5	DW	RM	2400	2.4	150.0	10.0	6.0E+00	6.0E+00	138.60	21.40	80.00	117.2	48.84	
		TS7	DW	BP	2400	2.4	150.0	0.0	6.0E+00	1.0E+99	136.71	0.00	68.35	136.7	56.96	
	EAST Side	TS2E	DW	IP	2400	2.4	150.0	60.0	6.0E+00	1.0E+99	142.03	60.00	101.01	82.0	34.18	
		TS3E	DW	XI	2400	2.4	150.0	110.0	6.0E+00	1.0E+99	146.46	110.00	128.23	36.5	15.19	
		TS6E	DW	PP	2400	2.4	150.0	100.0	6.0E+00	1.0E+99	145.57	100.00	122.78	45.6	18.99	
	WEST Side	TS2W	DW	IP	2400	2.4	150.0	60.0	6.0E+00	1.0E+99	142.03	60.00	101.01	82.0	34.18	
		TS3W	DW	XI	2400	2.4	150.0	110.0	6.0E+00	1.0E+99	146.46	110.00	128.23	36.5	15.19	
		TS6W	DW	PP	2400	2.4	150.0	100.0	6.0E+00	1.0E+99	145.57	100.00	122.78	45.6	18.99	
Pool Girder	E&W Side	PG3	RM	DS	1600	1.6	10.0	110.0	6.0E+00	1.0E+99	22.73	110.00	66.36	-87.3	-54.55	
		PG7	RM	BP	1600	1.6	10.0	0.0	6.0E+00	1.0E+99	8.73	0.00	4.36	8.7	5.45	
	EAST Side	PG1E	PP	RW	1600	1.6	100.0	110.0	1.0E+99	1.0E+99	100.00	110.00	105.00	-10.0	-6.25	
		PG2E	XI	BP	1600	1.6	110.0	0.0	1.0E+99	1.0E+99	110.00	0.00	55.00	110.0	68.75	
		PG4E	IP	DS	1600	1.6	60.0	110.0	1.0E+99	1.0E+99	60.00	110.00	85.00	-50.0	-31.25	
		PG5E	PP	DS	1600	1.6	100.0	110.0	1.0E+99	1.0E+99	100.00	110.00	105.00	-10.0	-6.25	
		PG6E	IP	BP	1600	1.6	60.0	0.0	1.0E+99	1.0E+99	60.00	0.00	30.00	60.0	37.50	
		PG8E	XS	DS	1600	1.6	0.0	110.0	1.0E+99	1.0E+99	0.00	110.00	55.00	-110.0	-68.75	
		PG9E	PP	BP	1600	1.6	100.0	0.0	1.0E+99	1.0E+99	100.00	0.00	50.00	100.0	62.50	
		WEST Side	PG1W	PP	RW	1600	1.6	100.0	110.0	1.0E+99	1.0E+99	100.00	110.00	105.00	-10.0	-6.25
			PG2W	XI	BP	1600	1.6	110.0	0.0	1.0E+99	1.0E+99	110.00	0.00	55.00	110.0	68.75
	PG4W		IP	DS	1600	1.6	60.0	110.0	1.0E+99	1.0E+99	60.00	110.00	85.00	-50.0	-31.25	
	PG5W		PP	DS	1600	1.6	100.0	110.0	1.0E+99	1.0E+99	100.00	110.00	105.00	-10.0	-6.25	
	PG6W		IP	BP	1600	1.6	60.0	0.0	1.0E+99	1.0E+99	60.00	0.00	30.00	60.0	37.50	
	PG8W		XS	DS	1600	1.6	0.0	110.0	1.0E+99	1.0E+99	0.00	110.00	55.00	-110.0	-68.75	
	PG9W		PP	BP	1600	1.6	100.0	0.0	1.0E+99	1.0E+99	100.00	0.00	50.00	100.0	62.50	



**Table 6.2.3.4-21 Thermal Loads for Shell Elements
LOCA: 72 hr.: Winter (Case 3) Continued**

Portion	Section*1	Side*2		Thick. t (mm) (m)	Temperature (°C)		Thin Film Coef. (kcal/m ² h°C)		Surface Temp. (°C)		Linearized Temp. (°C)				
		1	2		T1	T2	h1	h2	Ts1	Ts2	Td	Tg	Tg/t		
External Wall	E&W Side	GW1	AT RM	1500	1.5	-40.0	10.0	3.5E+01	6.0E+00	-38.87	3.42	-17.73	-42.3	-28.20	
		GW5	AT BP	2440	2.4	-40.0	0.0	3.5E+01	1.0E+99	-39.35	0.00	-19.68	-39.4	-16.13	
		GW6	DS AT	3500	3.5	110.0	-40.0	1.0E+99	3.5E+01	110.00	-38.31	35.85	148.3	42.37	
		GW9	AT RM	1000	1.0	-40.0	10.0	3.5E+01	6.0E+00	-38.43	0.84	-18.80	-39.3	-39.27	
		GW10	RM RM	1000	1.0	10.0	10.0	6.0E+00	6.0E+00	10.00	10.00	10.00	0.0	0.00	
		GW11	AT BP	1500	1.5	-40.0	0.0	3.5E+01	1.0E+99	-38.96	0.00	-19.48	-39.0	-25.97	
	EAST Side	GW3E	AT XO	1000	1.0	-40.0	0.0	3.5E+01	1.0E+99	-38.46	0.00	-19.23	-38.5	-38.46	
		GW7E	XS AT	1500	1.5	0.0	-40.0	1.0E+99	3.5E+01	0.00	-38.96	-19.48	39.0	25.97	
		GW8E	RM XO	1000	1.0	10.0	0.0	6.0E+00	1.0E+99	8.11	0.00	4.05	8.1	8.11	
		GW3W	AT XO	1000	1.0	-40.0	0.0	3.5E+01	1.0E+99	-38.46	0.00	-19.23	-38.5	-38.46	
		GW7W	XS AT	1500	1.5	0.0	-40.0	1.0E+99	3.5E+01	0.00	-38.96	-19.48	39.0	25.97	
		GW8W	RM XO	1000	1.0	10.0	0.0	6.0E+00	1.0E+99	8.11	0.00	4.05	8.1	8.11	
Pool Wall	E&W Side	PW10	RM RM	1000	1.0	10.0	10.0	6.0E+00	6.0E+00	10.00	10.00	10.00	0.0	0.00	
		PW11	RM RM	2000	2.0	10.0	10.0	6.0E+00	6.0E+00	10.00	10.00	10.00	0.0	0.00	
		PW19	BP RW	1300	1.3	0.0	110.0	1.0E+99	1.0E+99	0.00	110.00	55.00	-110.0	-84.62	
	EAST Side	PW1E	RW DS	1300	1.3	110.0	110.0	1.0E+99	1.0E+99	110.00	110.00	110.00	0.0	0.00	
		PW2E	PP PP	400	0.4	100.0	100.0	1.0E+99	1.0E+99	100.00	100.00	100.00	0.0	0.00	
		PW4E	XI PP	1000	1.0	110.0	100.0	1.0E+99	1.0E+99	110.00	100.00	105.00	10.0	10.00	
		PW6E	XI XS	1000	1.0	110.0	0.0	1.0E+99	1.0E+99	110.00	0.00	55.00	110.0	110.00	
		PW7E	XO XI	2000	2.0	0.0	110.0	1.0E+99	1.0E+99	0.00	110.00	55.00	-110.0	-55.00	
		PW8E	XI RM	1000	1.0	110.0	10.0	1.0E+99	6.0E+00	110.00	28.92	69.46	81.1	81.08	
		PW9E	RM XS	2000	2.0	10.0	0.0	6.0E+00	1.0E+99	8.96	0.00	4.48	9.0	4.48	
		PW12E	IP XI	1000	1.0	60.0	110.0	1.0E+99	1.0E+99	60.00	110.00	85.00	-50.0	-50.00	
		PW13E	IP RM	1000	1.0	60.0	10.0	1.0E+99	6.0E+00	60.00	19.46	39.73	40.5	40.54	
		PW14E	XI IP	470	0.5	110.0	60.0	1.0E+99	1.0E+99	110.00	60.00	85.00	50.0	106.38	
		PW15E	XI IP	1000	1.0	110.0	60.0	1.0E+99	1.0E+99	110.00	60.00	85.00	50.0	50.00	
		PW16E	PP IP	400	0.4	100.0	60.0	1.0E+99	1.0E+99	100.00	60.00	80.00	40.0	100.00	
		PW17E	XO RM	1000	1.0	0.0	10.0	1.0E+99	6.0E+00	0.00	8.11	4.05	-8.1	-8.11	
		PW18E	RM XS	1000	1.0	10.0	0.0	6.0E+00	1.0E+99	8.11	0.00	4.05	8.1	8.11	
		WEST Side	PW1W	RW DS	1300	1.3	110.0	110.0	1.0E+99	1.0E+99	110.00	110.00	110.00	0.0	0.00
			PW2W	PP PP	400	0.4	100.0	100.0	1.0E+99	1.0E+99	100.00	100.00	100.00	0.0	0.00
			PW4W	XI PP	1000	1.0	110.0	100.0	1.0E+99	1.0E+99	110.00	100.00	105.00	10.0	10.00
			PW6W	XI XS	1000	1.0	110.0	0.0	1.0E+99	1.0E+99	110.00	0.00	55.00	110.0	110.00
			PW7W	XO XI	2000	2.0	0.0	110.0	1.0E+99	1.0E+99	0.00	110.00	55.00	-110.0	-55.00
			PW8W	XI RM	1000	1.0	110.0	10.0	1.0E+99	6.0E+00	110.00	28.92	69.46	81.1	81.08
			PW9W	RM XS	2000	2.0	10.0	0.0	6.0E+00	1.0E+99	8.96	0.00	4.48	9.0	4.48
			PW12W	IP XI	1000	1.0	60.0	110.0	1.0E+99	1.0E+99	60.00	110.00	85.00	-50.0	-50.00
			PW13W	IP RM	1000	1.0	60.0	10.0	1.0E+99	6.0E+00	60.00	19.46	39.73	40.5	40.54
			PW14W	XI IP	470	0.5	110.0	60.0	1.0E+99	1.0E+99	110.00	60.00	85.00	50.0	106.38
			PW15W	XI IP	1000	1.0	110.0	60.0	1.0E+99	1.0E+99	110.00	60.00	85.00	50.0	50.00
			PW16W	PP IP	400	0.4	100.0	60.0	1.0E+99	1.0E+99	100.00	60.00	80.00	40.0	100.00
			PW17W	XO RM	1000	1.0	0.0	10.0	1.0E+99	6.0E+00	0.00	8.11	4.05	-8.1	-8.11
PW18W	RM XS	1000	1.0	10.0	0.0	6.0E+00	1.0E+99	8.11	0.00	4.05	8.1	8.11			

*1: Refer to Figures E 3-1 and E 3-2 in Reference 2.1.2-e.

*2: Side

- | | | |
|--------------------------|----------------------------|-------------------------|
| DW: Drywell | WW: Wetwell | SP: Suppression Pool |
| GP: GDSCS Pool | IP: IC Pool | PP: PCCS Pool |
| XI: Inner Expansion Pool | XO: Outer Expansion Pool | XS: Side Expansion Pool |
| RM: Room | DS: Equipment Storage Pool | BP: Buffer Pool |
| RW: Reactor Well | FP: Spent Fuel Pool | MT: MS Tunnel |
| GR: Ground | AT: Outside Air | |



**Table 6.2.3.4-22 Thermal Loads for Shell Elements
LOCA: 72 hr.: Winter (Case 4)**

Portion	Section ^{*1}	Side ^{*2}		Thick. t		Temperature (°C)		Thin Film Coef. (kcal/m ² h°C)		Surface Temp. (°C)		Linearized Temp. (°C)			
		1	2	(mm)	(m)	T1	T2	h1	h2	Ts1	Ts2	Td	Tg	Tg/t	
Floor Slab	E&W Side	SL1	RM	RM	-	-	10.0	10.0	6.0E+00	6.0E+00	10.00	10.00	10.00	0.0	0.00
		SL4	RM	BP	2400	2.4	10.0	0.0	6.0E+00	1.0E+99	9.11	0.00	4.56	9.1	3.80
		SL5	RM	AT	1000	1.0	10.0	-40.0	6.0E+00	3.5E+01	0.84	-38.43	-18.80	39.3	39.27
	EAST Side	SL2E	IP	RM	1000	1.0	0.0	10.0	1.0E+99	6.0E+00	0.00	8.11	4.05	-8.1	-8.11
		SL3E	RM	XI	1500	1.5	10.0	0.0	6.0E+00	1.0E+99	8.65	0.00	4.33	8.7	5.77
		SL6E	XO	AT	1000	1.0	0.0	-40.0	1.0E+99	3.5E+01	0.00	-38.46	-19.23	38.5	38.46
		SL9E	RM	XO	1500	1.5	10.0	0.0	6.0E+00	1.0E+99	8.65	0.00	4.33	8.7	5.77
		SL10E	RM	XS	1500	1.5	10.0	0.0	6.0E+00	1.0E+99	8.65	0.00	4.33	8.7	5.77
		SL11E	XS	RM	1000	1.0	0.0	10.0	1.0E+99	6.0E+00	0.00	8.11	4.05	-8.1	-8.11
		SL12E	PP	RM	1000	1.0	0.0	10.0	1.0E+99	6.0E+00	0.00	8.11	4.05	-8.1	-8.11
		SL13E	XI	RM	1000	1.0	0.0	10.0	1.0E+99	6.0E+00	0.00	8.11	4.05	-8.1	-8.11
	WEST Side	SL2W	IP	RM	1000	1.0	0.0	10.0	1.0E+99	6.0E+00	0.00	8.11	4.05	-8.1	-8.11
		SL3W	RM	XI	1500	1.5	10.0	0.0	6.0E+00	1.0E+99	8.65	0.00	4.33	8.7	5.77
		SL6W	XO	AT	1000	1.0	0.0	-40.0	1.0E+99	3.5E+01	0.00	-38.46	-19.23	38.5	38.46
		SL9W	RM	XO	1500	1.5	10.0	0.0	6.0E+00	1.0E+99	8.65	0.00	4.33	8.7	5.77
		SL10W	RM	XS	1500	1.5	10.0	0.0	6.0E+00	1.0E+99	8.65	0.00	4.33	8.7	5.77
SL11W		XS	RM	1000	1.0	0.0	10.0	1.0E+99	6.0E+00	0.00	8.11	4.05	-8.1	-8.11	
SL12W		PP	RM	1000	1.0	0.0	10.0	1.0E+99	6.0E+00	0.00	8.11	4.05	-8.1	-8.11	
SL13W		XI	RM	1000	1.0	0.0	10.0	1.0E+99	6.0E+00	0.00	8.11	4.05	-8.1	-8.11	
MS Tunnel	E&W Side	MT5	MT	DS	2400	2.4	57.0	0.0	1.0E+99	1.0E+99	57.00	0.00	28.50	57.0	23.75
		MT8	MT	AT	2400	2.4	57.0	-40.0	1.0E+99	3.5E+01	57.00	-38.41	9.30	95.4	39.75
		MT9	MT	RM	2400	2.4	57.0	10.0	1.0E+99	6.0E+00	57.00	14.16	35.58	42.8	17.85
	EAST Side	MT6E	MT	XS	2400	2.4	57.0	0.0	1.0E+99	1.0E+99	57.00	0.00	28.50	57.0	23.75
	WEST Side	MT6W	MT	XS	2400	2.4	57.0	0.0	1.0E+99	1.0E+99	57.00	0.00	28.50	57.0	23.75
	Top Slab	E&W Side	TS1	DW	DS	2400	2.4	150.0	0.0	6.0E+00	1.0E+99	136.71	0.00	68.35	136.7
TS4			DW	RW	2400	2.4	150.0	0.0	6.0E+00	1.0E+99	136.71	0.00	68.35	136.7	56.96
TS5			DW	RM	2400	2.4	150.0	10.0	6.0E+00	6.0E+00	138.60	21.40	80.00	117.2	48.84
TS7			DW	BP	2400	2.4	150.0	0.0	6.0E+00	1.0E+99	136.71	0.00	68.35	136.7	56.96
EAST Side		TS2E	DW	IP	2400	2.4	150.0	0.0	6.0E+00	1.0E+99	136.71	0.00	68.35	136.7	56.96
		TS3E	DW	XI	2400	2.4	150.0	0.0	6.0E+00	1.0E+99	136.71	0.00	68.35	136.7	56.96
		TS6E	DW	PP	2400	2.4	150.0	0.0	6.0E+00	1.0E+99	136.71	0.00	68.35	136.7	56.96
WEST Side		TS2W	DW	IP	2400	2.4	150.0	0.0	6.0E+00	1.0E+99	136.71	0.00	68.35	136.7	56.96
		TS3W	DW	XI	2400	2.4	150.0	0.0	6.0E+00	1.0E+99	136.71	0.00	68.35	136.7	56.96
		TS6W	DW	PP	2400	2.4	150.0	0.0	6.0E+00	1.0E+99	136.71	0.00	68.35	136.7	56.96
Pool Girder	E&W Side	PG3	RM	DS	1600	1.6	10.0	0.0	6.0E+00	1.0E+99	8.73	0.00	4.36	8.7	5.45
		PG7	RM	BP	1600	1.6	10.0	0.0	6.0E+00	1.0E+99	8.73	0.00	4.36	8.7	5.45
	EAST Side	PG1E	PP	RW	1600	1.6	0.0	0.0	1.0E+99	1.0E+99	0.00	0.00	0.00	0.0	0.00
		PG2E	XI	BP	1600	1.6	0.0	0.0	1.0E+99	1.0E+99	0.00	0.00	0.00	0.0	0.00
		PG4E	IP	DS	1600	1.6	0.0	0.0	1.0E+99	1.0E+99	0.00	0.00	0.00	0.0	0.00
		PG5E	PP	DS	1600	1.6	0.0	0.0	1.0E+99	1.0E+99	0.00	0.00	0.00	0.0	0.00
		PG6E	IP	BP	1600	1.6	0.0	0.0	1.0E+99	1.0E+99	0.00	0.00	0.00	0.0	0.00
		PG8E	XS	DS	1600	1.6	0.0	0.0	1.0E+99	1.0E+99	0.00	0.00	0.00	0.0	0.00
		PG9E	PP	BP	1600	1.6	0.0	0.0	1.0E+99	1.0E+99	0.00	0.00	0.00	0.0	0.00
		WEST Side	PG1W	PP	RW	1600	1.6	0.0	0.0	1.0E+99	1.0E+99	0.00	0.00	0.00	0.0
	PG2W		XI	BP	1600	1.6	0.0	0.0	1.0E+99	1.0E+99	0.00	0.00	0.00	0.0	0.00
	PG4W		IP	DS	1600	1.6	0.0	0.0	1.0E+99	1.0E+99	0.00	0.00	0.00	0.0	0.00
	PG5W		PP	DS	1600	1.6	0.0	0.0	1.0E+99	1.0E+99	0.00	0.00	0.00	0.0	0.00
	PG6W		IP	BP	1600	1.6	0.0	0.0	1.0E+99	1.0E+99	0.00	0.00	0.00	0.0	0.00
	PG8W		XS	DS	1600	1.6	0.0	0.0	1.0E+99	1.0E+99	0.00	0.00	0.00	0.0	0.00
PG9W	PP		BP	1600	1.6	0.0	0.0	1.0E+99	1.0E+99	0.00	0.00	0.00	0.0	0.00	



**Table 6.2.3.4-22 Thermal Loads for Shell Elements
LOCA: 72 hr.: Winter (Case 4) Continued**

Portion	Section ^{*1}	Side ^{*2}		Thick. t		Temperature (°C)		Thin Film Coef. (kcal/m ² h°C)		Surface Temp. (°C)		Linearized Temp. (°C)			
		1	2	(mm)	(m)	T1	T2	h1	h2	Ts1	Ts2	Td	Tg	Tg/t	
External Wall	E&W Side	GW1	AT	RM	1500	1.5	-40.0	10.0	3.5E+01	6.0E+00	-38.87	3.42	-17.73	-42.3	-28.20
		GW5	AT	BP	2440	2.4	-40.0	0.0	3.5E+01	1.0E+99	-39.35	0.00	-19.68	-39.4	-16.13
		GW6	DS	AT	3500	3.5	0.0	-40.0	1.0E+99	3.5E+01	0.00	-39.55	-19.77	39.5	11.30
		GW9	AT	RM	1000	1.0	-40.0	10.0	3.5E+01	6.0E+00	-38.43	0.84	-18.80	-39.3	-39.27
		GW10	RM	RM	1000	1.0	10.0	10.0	6.0E+00	6.0E+00	10.00	10.00	10.00	0.0	0.00
		GW11	AT	BP	1500	1.5	-40.0	0.0	3.5E+01	1.0E+99	-38.96	0.00	-19.48	-39.0	-25.97
	EAST Side	GW3E	AT	XO	1000	1.0	-40.0	0.0	3.5E+01	1.0E+99	-38.46	0.00	-19.23	-38.5	-38.46
		GW7E	XS	AT	1500	1.5	0.0	-40.0	1.0E+99	3.5E+01	0.00	-38.96	-19.48	39.0	25.97
		GW8E	RM	XO	1000	1.0	10.0	0.0	6.0E+00	1.0E+99	8.11	0.00	4.05	8.1	8.11
	WEST Side	GW3W	AT	XO	1000	1.0	-40.0	0.0	3.5E+01	1.0E+99	-38.46	0.00	-19.23	-38.5	-38.46
		GW7W	XS	AT	1500	1.5	0.0	-40.0	1.0E+99	3.5E+01	0.00	-38.96	-19.48	39.0	25.97
		GW8W	RM	XO	1000	1.0	10.0	0.0	6.0E+00	1.0E+99	8.11	0.00	4.05	8.1	8.11
Pool Wall	E&W Side	PW10	RM	RM	1000	1.0	10.0	10.0	6.0E+00	6.0E+00	10.00	10.00	10.00	0.0	0.00
		PW11	RM	RM	2000	2.0	10.0	10.0	6.0E+00	6.0E+00	10.00	10.00	10.00	0.0	0.00
		PW19	BP	RW	1300	1.3	0.0	0.0	1.0E+99	1.0E+99	0.00	0.00	0.00	0.0	0.00
	EAST Side	PW1E	RW	DS	1300	1.3	0.0	0.0	1.0E+99	1.0E+99	0.00	0.00	0.00	0.0	0.00
		PW2E	PP	PP	400	0.4	0.0	0.0	1.0E+99	1.0E+99	0.00	0.00	0.00	0.0	0.00
		PW4E	XI	PP	1000	1.0	0.0	0.0	1.0E+99	1.0E+99	0.00	0.00	0.00	0.0	0.00
		PW6E	XI	XS	1000	1.0	0.0	0.0	1.0E+99	1.0E+99	0.00	0.00	0.00	0.0	0.00
		PW7E	XO	XI	2000	2.0	0.0	0.0	1.0E+99	1.0E+99	0.00	0.00	0.00	0.0	0.00
		PW8E	XI	RM	1000	1.0	0.0	10.0	1.0E+99	6.0E+00	0.00	8.11	4.05	-8.1	-8.11
		PW9E	RM	XS	2000	2.0	10.0	0.0	6.0E+00	1.0E+99	8.96	0.00	4.48	9.0	4.48
		PW12E	IP	XI	1000	1.0	0.0	0.0	1.0E+99	1.0E+99	0.00	0.00	0.00	0.0	0.00
		PW13E	IP	RM	1000	1.0	0.0	10.0	1.0E+99	6.0E+00	0.00	8.11	4.05	-8.1	-8.11
		PW14E	XI	IP	470	0.5	0.0	0.0	1.0E+99	1.0E+99	0.00	0.00	0.00	0.0	0.00
		PW15E	XI	IP	1000	1.0	0.0	0.0	1.0E+99	1.0E+99	0.00	0.00	0.00	0.0	0.00
		PW16E	PP	IP	400	0.4	0.0	0.0	1.0E+99	1.0E+99	0.00	0.00	0.00	0.0	0.00
		PW17E	XO	RM	1000	1.0	0.0	10.0	1.0E+99	6.0E+00	0.00	8.11	4.05	-8.1	-8.11
		PW18E	RM	XS	1000	1.0	10.0	0.0	6.0E+00	1.0E+99	8.11	0.00	4.05	8.1	8.11
	WEST Side	PW1W	RW	DS	1300	1.3	0.0	0.0	1.0E+99	1.0E+99	0.00	0.00	0.00	0.0	0.00
		PW2W	PP	PP	400	0.4	0.0	0.0	1.0E+99	1.0E+99	0.00	0.00	0.00	0.0	0.00
		PW4W	XI	PP	1000	1.0	0.0	0.0	1.0E+99	1.0E+99	0.00	0.00	0.00	0.0	0.00
		PW6W	XI	XS	1000	1.0	0.0	0.0	1.0E+99	1.0E+99	0.00	0.00	0.00	0.0	0.00
		PW7W	XO	XI	2000	2.0	0.0	0.0	1.0E+99	1.0E+99	0.00	0.00	0.00	0.0	0.00
		PW8W	XI	RM	1000	1.0	0.0	10.0	1.0E+99	6.0E+00	0.00	8.11	4.05	-8.1	-8.11
		PW9W	RM	XS	2000	2.0	10.0	0.0	6.0E+00	1.0E+99	8.96	0.00	4.48	9.0	4.48
		PW12W	IP	XI	1000	1.0	0.0	0.0	1.0E+99	1.0E+99	0.00	0.00	0.00	0.0	0.00
		PW13W	IP	RM	1000	1.0	0.0	10.0	1.0E+99	6.0E+00	0.00	8.11	4.05	-8.1	-8.11
		PW14W	XI	IP	470	0.5	0.0	0.0	1.0E+99	1.0E+99	0.00	0.00	0.00	0.0	0.00
PW15W	XI	IP	1000	1.0	0.0	0.0	1.0E+99	1.0E+99	0.00	0.00	0.00	0.0	0.00		
PW16W	PP	IP	400	0.4	0.0	0.0	1.0E+99	1.0E+99	0.00	0.00	0.00	0.0	0.00		
PW17W	XO	RM	1000	1.0	0.0	10.0	1.0E+99	6.0E+00	0.00	8.11	4.05	-8.1	-8.11		
PW18W	RM	XS	1000	1.0	10.0	0.0	6.0E+00	1.0E+99	8.11	0.00	4.05	8.1	8.11		

*1: Refer to Figures E 3-1 and E 3-2 in Reference 2.1.2-e.

*2: Boundary

- | | | |
|--------------------------|----------------------------|-------------------------|
| DW: Drywell | WW: Wetwell | SP: Suppression Pool |
| GP: GDCS Pool | IP: IC Pool | PP: PCCS Pool |
| XI: Inner Expansion Pool | XO: Outer Expansion Pool | XS: Side Expansion Pool |
| RM: Room | DS: Equipment Storage Pool | BP: Buffer Pool |
| RW: Reactor Well | FP: Spent Fuel Pool | MT: MS Tunnel |
| GR: Ground | AT: Outside Air | |



Table 6.2.3.7-1 Design Wind Loads (North Wind)

FL	EL	RB (MPa)					EL	FB (MPa)			
		Wall				Roof		Wall			Roof
		N	S	E	W			S	E	W	
Roof ~ 6FL	34000 ~ 52400*1	0.0031	-0.0022	-0.0028	-0.0028	-0.0039					
6FL ~ 5FL	27000 ~ 34000	0.0029	-0.0022	-0.0028	-0.0028	-0.0039					
5FL ~ 4FL*2	17500 ~ 27000	0.0028	-0.0022	-0.0028	-0.0028		17500 ~ 22500	-0.0022	-0.0028	-0.0028	-0.0039
4FL ~ 3FL	13570 ~ 17500	0.0026		-0.0028	-0.0028		13570 ~ 17500	-0.0022	-0.0028	-0.0028	
3FL ~ 2FL	9060 ~ 13570	0.0025		-0.0028	-0.0028		9060 ~ 13570	-0.0022	-0.0028	-0.0028	
2FL ~ 1FL	4650 ~ 9060	0.0023		-0.0028	-0.0028		4650 ~ 9060	-0.0022	-0.0028	-0.0028	

Note

*1: The difference between the modeled elevation 52.4 m and the actual elevation 52.7 m at the RB roof is negligibly small.

*2: For RB South wall from EL 22500 to EL 27000.

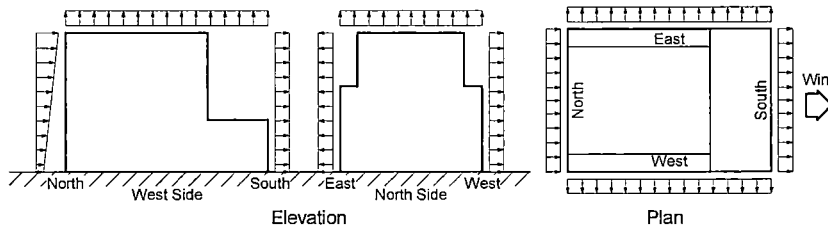


Table 6.2.3.7-2 Design Wind Loads (South Wind)

FL	EL	RB (MPa)					EL	FB (MPa)			
		Wall				Roof		Wall			Roof
		N	S	E	W			S	E	W	
Roof ~ 6FL	34000 ~ 52400*1	-0.0022	0.0031	-0.0028	-0.0028	-0.0039					
6FL ~ 5FL	27000 ~ 34000	-0.0022	0.0029	-0.0028	-0.0028	-0.0039					
5FL ~ 4FL*2	17500 ~ 27000	-0.0022	0.0028	-0.0028	-0.0028		17500 ~ 22500	0.0027	-0.0028	-0.0028	-0.0039
4FL ~ 3FL	13570 ~ 17500	-0.0022		-0.0028	-0.0028		13570 ~ 17500	0.0026	-0.0028	-0.0028	
3FL ~ 2FL	9060 ~ 13570	-0.0022		-0.0028	-0.0028		9060 ~ 13570	0.0025	-0.0028	-0.0028	
2FL ~ 1FL	4650 ~ 9060	-0.0022		-0.0028	-0.0028		4650 ~ 9060	0.0023	-0.0028	-0.0028	

Note

*1: The difference between the modeled elevation 52.4 m and the actual elevation 52.7 m at the RB roof is negligibly small.

*2: For RB South wall from EL 22500 to EL 27000.

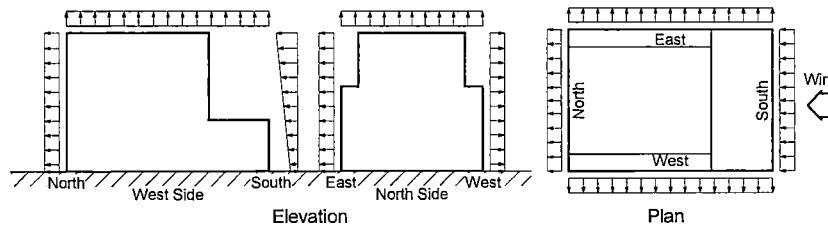




Table 6.2.3.7-3 Design Wind Loads (East Wind)

FL	EL	RB (MPa)					EL	FB (MPa)			
		Wall				Roof		Wall			Roof
		N	S	E	W			S	E	W	
Roof ~ 6FL	34000 ~ 52400*1	-0.0028	-0.0028	0.0031	-0.0022	-0.0039					
6FL ~ 5FL	27000 ~ 34000	-0.0028	-0.0028	0.0029	-0.0022	-0.0039					
5FL ~ 4FL*2	17500 ~ 27000	-0.0028	-0.0028	0.0028	-0.0022		17500 ~ 22500	-0.0028	0.0027	-0.0022	-0.0039
4FL ~ 3FL	13570 ~ 17500	-0.0028		0.0026	-0.0022		13570 ~ 17500	-0.0028	0.0026	-0.0022	
3FL ~ 2FL	9060 ~ 13570	-0.0028		0.0025	-0.0022		9060 ~ 13570	-0.0028	0.0025	-0.0022	
2FL ~ 1FL	4650 ~ 9060	-0.0028		0.0023	-0.0022		4650 ~ 9060	-0.0028	0.0023	-0.0022	

Note

*1: The difference between the modeled elevation 52.4 m and the actual elevation 52.7 m at the RB roof is negligibly small.

*2: For RB South wall from EL 22500 to EL 27000.

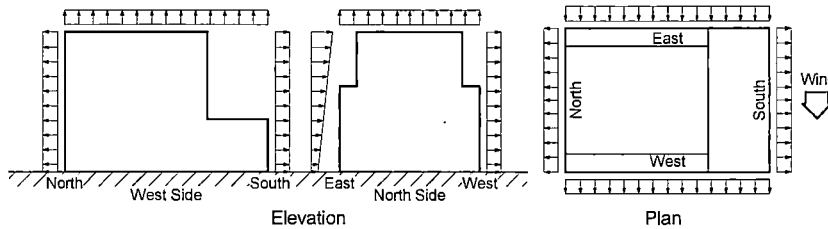


Table 6.2.3.7-4 Design Wind Loads (West Wind)

FL	EL	RB (MPa)					EL	FB (MPa)			
		Wall				Roof		Wall			Roof
		N	S	E	W			S	E	W	
Roof ~ 6FL	34000 ~ 52400*1	-0.0028	-0.0028	-0.0022	0.0031	-0.0039					
6FL ~ 5FL	27000 ~ 34000	-0.0028	-0.0028	-0.0022	0.0029	-0.0039					
5FL ~ 4FL*2	17500 ~ 27000	-0.0028	-0.0028	-0.0022	0.0028		17500 ~ 22500	-0.0028	-0.0022	0.0027	-0.0039
4FL ~ 3FL	13570 ~ 17500	-0.0028		-0.0022	0.0026		13570 ~ 17500	-0.0028	-0.0022	0.0026	
3FL ~ 2FL	9060 ~ 13570	-0.0028		-0.0022	0.0025		9060 ~ 13570	-0.0028	-0.0022	0.0025	
2FL ~ 1FL	4650 ~ 9060	-0.0028		-0.0022	0.0023		4650 ~ 9060	-0.0028	-0.0022	0.0023	

Note

*1: The difference between the modeled elevation 52.4 m and the actual elevation 52.7 m at the RB roof is negligibly small.

*2: For RB South wall from EL 22500 to EL 27000.

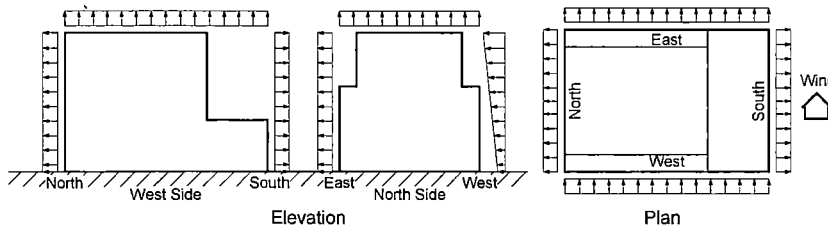




Table 6.2.3.8-1 Tornado Wind Loads (North Wind)

FL	EL	RB (MPa)					EL	FB (MPa)			
		Wall				Roof		Wall			Roof
		N	S	E	W			S	E	W	
Roof ~ 6FL	34000 ~ 52400 ^{*1}	0.0056	-0.0035	-0.0049	-0.0049	-0.0073					
6FL ~ 5FL	27000 ~ 34000	0.0056	-0.0035	-0.0049	-0.0049	-0.0073					
5FL ~ 4FL ^{*2}	17500 ~ 27000	0.0056	-0.0035	-0.0049	-0.0049		17500 ~ 22500	-0.0035	-0.0049	-0.0049	-0.0073
4FL ~ 3FL	13570 ~ 17500	0.0056		-0.0049	-0.0049		13570 ~ 17500	-0.0035	-0.0049	-0.0049	
3FL ~ 2FL	9060 ~ 13570	0.0056		-0.0049	-0.0049		9060 ~ 13570	-0.0035	-0.0049	-0.0049	
2FL ~ 1FL	4650 ~ 9060	0.0056		-0.0049	-0.0049		4650 ~ 9060	-0.0035	-0.0049	-0.0049	

Note

*1: The difference between the modeled elevation 52.4 m and the actual elevation 52.7 m at the RB roof is negligibly small.

*2: For RB South wall from EL 22500 to EL 27000.

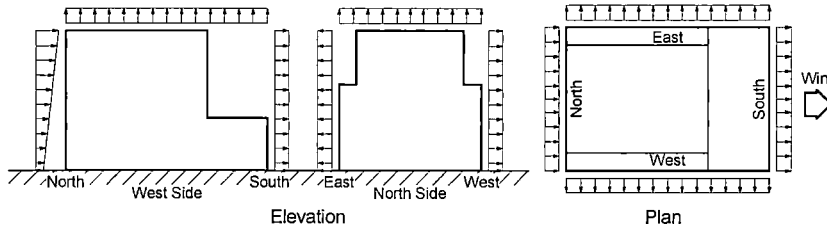


Table 6.2.3.8-2 Tornado Wind Loads (South Wind)

FL	EL	RB (MPa)					EL	FB (MPa)			
		Wall				Roof		Wall			Roof
		N	S	E	W			S	E	W	
Roof ~ 6FL	34000 ~ 52400 ^{*1}	-0.0035	0.0056	-0.0049	-0.0049	-0.0073					
6FL ~ 5FL	27000 ~ 34000	-0.0035	0.0056	-0.0049	-0.0049	-0.0073					
5FL ~ 4FL ^{*2}	17500 ~ 27000	-0.0035	0.0056	-0.0049	-0.0049		17500 ~ 22500	0.0056	-0.0049	-0.0049	-0.0073
4FL ~ 3FL	13570 ~ 17500	-0.0035		-0.0049	-0.0049		13570 ~ 17500	0.0056	-0.0049	-0.0049	
3FL ~ 2FL	9060 ~ 13570	-0.0035		-0.0049	-0.0049		9060 ~ 13570	0.0056	-0.0049	-0.0049	
2FL ~ 1FL	4650 ~ 9060	-0.0035		-0.0049	-0.0049		4650 ~ 9060	0.0056	-0.0049	-0.0049	

Note

*1: The difference between the modeled elevation 52.4 m and the actual elevation 52.7 m at the RB roof is negligibly small.

*2: For RB South wall from EL 22500 to EL 27000.

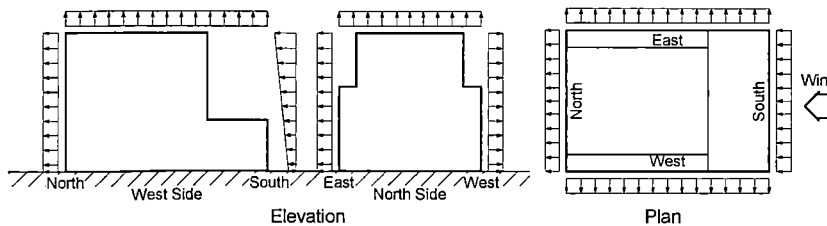




Table 6.2.3.8-3 Tornado Wind Loads (East Wind)

FL	EL	RB (MPa)					EL	FB (MPa)			
		Wall				Roof		Wall			Roof
		N	S	E	W			S	E	W	
Roof ~ 6FL	34000 ~ 52400* ¹	-0.0049	-0.0049	0.0056	-0.0035	-0.0073					
6FL ~ 5FL	27000 ~ 34000	-0.0049	-0.0049	0.0056	-0.0035	-0.0073					
5FL ~ 4FL* ²	17500 ~ 27000	-0.0049	-0.0049	0.0056	-0.0035		17500 ~ 22500	-0.0049	0.0056	-0.0035	-0.0073
4FL ~ 3FL	13570 ~ 17500	-0.0049		0.0056	-0.0035		13570 ~ 17500	-0.0049	0.0056	-0.0035	
3FL ~ 2FL	9060 ~ 13570	-0.0049		0.0056	-0.0035		9060 ~ 13570	-0.0049	0.0056	-0.0035	
2FL ~ 1FL	4650 ~ 9060	-0.0049		0.0056	-0.0035		4650 ~ 9060	-0.0049	0.0056	-0.0035	

Note

*1: The difference between the modeled elevation 52.4 m and the actual elevation 52.7 m at the RB roof is negligibly small.

*2: For RB South wall from EL 22500 to EL 27000.

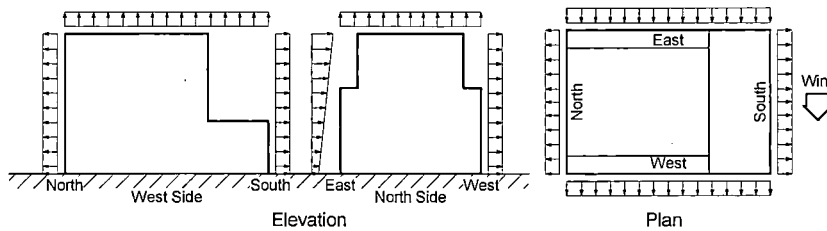


Table 6.2.3.8-4 Tornado Wind Loads (West Wind)

FL	EL	RB (MPa)					EL	FB (MPa)			
		Wall				Roof		Wall			Roof
		N	S	E	W			S	E	W	
Roof ~ 6FL	34000 ~ 52400* ¹	-0.0049	-0.0049	-0.0035	0.0056	-0.0073					
6FL ~ 5FL	27000 ~ 34000	-0.0049	-0.0049	-0.0035	0.0056	-0.0073					
5FL ~ 4FL* ²	17500 ~ 27000	-0.0049	-0.0049	-0.0035	0.0056		17500 ~ 22500	-0.0049	-0.0035	0.0056	-0.0073
4FL ~ 3FL	13570 ~ 17500	-0.0049		-0.0035	0.0056		13570 ~ 17500	-0.0049	-0.0035	0.0056	
3FL ~ 2FL	9060 ~ 13570	-0.0049		-0.0035	0.0056		9060 ~ 13570	-0.0049	-0.0035	0.0056	
2FL ~ 1FL	4650 ~ 9060	-0.0049		-0.0035	0.0056		4650 ~ 9060	-0.0049	-0.0035	0.0056	

Note

*1: The difference between the modeled elevation 52.4 m and the actual elevation 52.7 m at the RB roof is negligibly small.

*2: For RB South wall from EL 22500 to EL 27000.

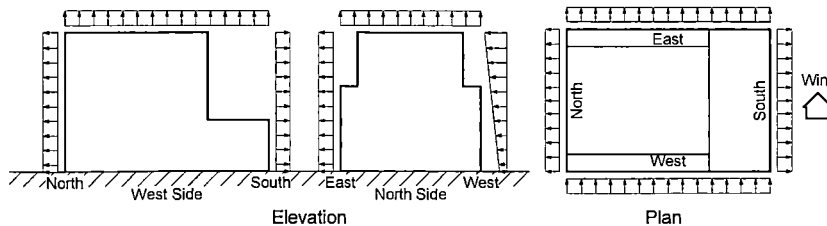




Table 6.2.3.8-5 Tornado Loads (Differential Pressure)

FL	EL	RB (MPa)					EL	FB (MPa)			
		Wall				Roof		Wall			Roof
		N	S	E	W			S	E	W	
Roof ~ 6FL	34000 ~ 52400 ^{*1}	0.0165	0.0165	0.0165	0.0165	0.0165					
6FL ~ 5FL	27000 ~ 34000	0.0165	0.0165	0.0165	0.0165	0.0165					
5FL ~ 4FL ^{*2}	17500 ~ 27000	0.0165	0.0165	0.0165	0.0165		17500 ~ 22500	0.0165	0.0165	0.0165	0.0165
4FL ~ 3FL	13570 ~ 17500	0.0165		0.0165	0.0165		13570 ~ 17500	0.0165	0.0165	0.0165	
3FL ~ 2FL	9060 ~ 13570	0.0165		0.0165	0.0165		9060 ~ 13570	0.0165	0.0165	0.0165	
2FL ~ 1FL	4650 ~ 9060	0.0165		0.0165	0.0165		4650 ~ 9060	0.0165	0.0165	0.0165	

Note

*1: The difference between the modeled elevation 52.4 m and the actual elevation 52.7 m at the RB roof is negligibly small.

*2: For RB South wall from EL 22500 to EL 27000.

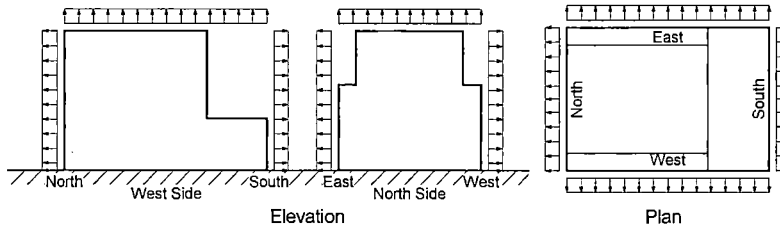




Table 6.2.3.9-1 Analysis Cases for Seismic Loads

Condition	Load	Load Label	Direction	Component
Normal Operation & LOCA	Horizontal Seismic Load	EQNS	North to South	Shear Force Overturning Moment
		EQEW	West to East	Shear Force Overturning Moment
	Vertical Seismic Load	EQZ	Downward	Vertical Force
	Torsional Seismic Load	EQT	Counterclockwise	Torsional Moment
	Soil Pressure Due to an Earthquake	SPKN	North to South and South to North at Once	Soil Pressure
		SPKW	West to East and East to West at Once	Soil Pressure
	Sloshing Load	ESX	North to South	Sloshing Pressure
		ESY	West to East	Sloshing Pressure
		ESZ	Downward	Sloshing Pressure
	LOCA Flooding	Horizontal Seismic Load	EQNF	North to South
EQEF			West to East	Shear Force Overturning Moment
Vertical Seismic Load		EQZF	Downward	Vertical Force
Torsional seismic Load		EQTF	Counterclockwise	Torsional Moment
Sloshing Load		ESXF	North to South	Sloshing Pressure
		ESYF	West to East	Sloshing Pressure
		ESZF	Downward	Sloshing Pressure
Envelope	Horizontal Seismic Load	EONS	North to South	Out-of-plane force
	(Out-of-plane load for walls)	EOEW	West to East	Out-of-plane force

Note: The seismic loads for normal operation & LOCA condition are the same seismic loads for LOCA flooding condition.



HITACHI

Table 6.2.3.9-2 Seismic Wall Shear Area – X(N-S)-dir.

Elevation (m)	Seismic Wall Shear Area (m ²)											Total (m ²)	
	RA	RG	RCCV	Pedestal	IW1	IW2	IW3	IW4	IW5	IW6	IW7		IW8
*1 52.40 34.00	47.0	47.0											94.0
34.00 27.00	47.0	47.0											94.0
27.00 22.50	47.0	47.0	119.3										213.3
22.50 17.50	91.5	91.5	119.3										302.3
17.50 13.57	91.5	91.5	119.3										302.3
13.57 9.06	91.5	91.5	119.3										302.3
9.06 4.65	91.5	91.5	119.3										302.3
4.65 2.42	136.0	136.0	119.3	51.2	7.4	4.2	19.4	12.2	12.9				498.5
2.42 -1.00	136.0	136.0	119.3	51.2	7.4	4.2	19.4	12.2	12.9				498.5
-1.00 -2.75	136.0	136.0	119.3	51.2	7.4	4.2	19.4	12.2	10.4				496.0
-2.75 -6.40	136.0	136.0	119.3	51.2	7.4	4.2	19.4	12.2	10.4				496.0
-6.40 -11.50	136.0	136.0	119.3	51.2	7.4	3.2	19.4	12.2	12.9	10.1	12.0	12.0	531.5

Note

*1: The difference between the modeled elevation 52.4 m and the actual elevation 52.7 m at the RB roof is negligibly small.



Table 6.2.3.9-3 Seismic Wall Shear Area – Y(E-W)-dir.

Elevation (m)	Seismic Wall Shear Area (m ²)														Total (m ²)
	R1	R7	F3	RCCV	Pedestal	IW1	IW2	IW3	IW4	IW5	IW6	IW7	IW8	IW9	
*1 52.40 34.00	38.0	38.0													76.0
34.00 27.00	75.2	75.2													150.4
27.00 22.50	70.5	70.5		119.3											260.3
22.50 17.50	43.5	70.5	47.0	119.3											280.3
17.50 13.57	70.5	70.5	47.0	119.3											307.3
13.57 9.06	70.5	70.5	47.0	119.3											307.3
9.06 4.65	70.5	70.5	47.0	119.3											307.3
4.65 2.42	94.0	94.0	94.0	119.3	51.2	31.5	4.1	2.8							491.0
2.42 -1.00	94.0	94.0	94.0	119.3	51.2	31.5	4.1	2.8							491.0
-1.00 -2.75	94.0	94.0	94.0	119.3	51.2	31.5	4.1	8.3							496.5
-2.75 -6.40	94.0	94.0	94.0	119.3	51.2	31.5	4.1	8.3							496.5
-6.40 -11.50	94.0	94.0	94.0	119.3	51.2	31.5	8.2	8.4	5.5	6.3	6.8	8.4	12.0	12.0	551.7

Note

*1: The difference between the modeled elevation 52.4 m and the actual elevation 52.7 m at the RB roof is negligibly small.



Table 6.2.3.9-4 Applied Shear Forces at Seismic Wall – X(N-S)-dir.

Elevation (m)	Design Shear Force (MN)	Applied Force (MN)	Applied Forces at Each Seismic Wall (MN)											
			RA	RG	RCCV	Pedestal	IW1	IW2	IW3	IW4	IW5	IW6	IW7	IW8
52.40 34.00	192.21	192.21	96.11	96.11	0.00	0.00	0.00	0.00	0.00	0.00	0.00	0.00	0.00	0.00
34.00 27.00	304.11	111.90	55.95	55.95	0.00	0.00	0.00	0.00	0.00	0.00	0.00	0.00	0.00	0.00
27.00 22.50	537.06	232.95	51.32	51.32	130.30	0.00	0.00	0.00	0.00	0.00	0.00	0.00	0.00	0.00
22.50 17.50	577.43	40.37	12.22	12.22	15.93	0.00	0.00	0.00	0.00	0.00	0.00	0.00	0.00	0.00
17.50 13.57	622.58	45.15	13.66	13.66	17.82	0.00	0.00	0.00	0.00	0.00	0.00	0.00	0.00	0.00
13.57 9.06	658.62	36.04	10.91	10.91	14.22	0.00	0.00	0.00	0.00	0.00	0.00	0.00	0.00	0.00
9.06 4.65	680.00	21.38	6.47	6.47	8.44	0.00	0.00	0.00	0.00	0.00	0.00	0.00	0.00	0.00
4.65 2.42	584.43	-95.58	-26.07	-26.07	-22.88	-9.82	-1.41	-0.81	-3.71	-2.33	-2.47	0.00	0.00	0.00
2.42 -1.00	595.94	11.51	3.14	3.14	2.75	1.18	0.17	0.10	0.45	0.28	0.30	0.00	0.00	0.00
-1.00 -2.75	329.76	-266.18	-72.98	-72.98	-64.03	-27.50	-3.94	-2.25	-10.38	-6.52	-5.58	0.00	0.00	0.00
-2.75 -6.40	329.40	-0.36	-0.10	-0.10	-0.09	-0.04	-0.01	0.00	-0.01	-0.01	-0.01	0.00	0.00	0.00
-6.40 -11.50	338.24	8.48	0.22	0.22	0.19	7.70	0.01	0.01	0.03	0.02	0.02	0.02	0.02	0.02
-11.50 -15.50	---	215.98												

Note

*1: The difference between the modeled elevation 52.4 m and the actual elevation 52.7 m at the RB roof is negligibly small.



Table 6.2.3.9-5 Applied Shear Forces at Seismic Wall – Y(E-W)-dir.

Elevation (m)	Design Shear Force (MN)	Applied Force (MN)	Applied Forces at Each Seismic Wall (MN)													
			R1	R7	F3	RCCV	Pedestal	IW1	IW2	IW3	IW4	IW5	IW6	IW7	IW8	IW9
52.40 34.00	139.97	139.97	69.98	69.98	0.00	0.00	0.00	0.00	0.00	0.00	0.00	0.00	0.00	0.00	0.00	0.00
34.00 27.00	247.18	107.22	53.61	53.61	0.00	0.00	0.00	0.00	0.00	0.00	0.00	0.00	0.00	0.00	0.00	0.00
27.00 22.50	411.28	164.10	44.44	44.44	0.00	75.22	0.00	0.00	0.00	0.00	0.00	0.00	0.00	0.00	0.00	0.00
22.50 17.50	443.71	32.43	5.03	8.16	5.44	13.80	0.00	0.00	0.00	0.00	0.00	0.00	0.00	0.00	0.00	0.00
17.50 13.57	501.87	58.16	13.34	13.34	8.89	22.58	0.00	0.00	0.00	0.00	0.00	0.00	0.00	0.00	0.00	0.00
13.57 9.06	537.18	35.31	8.10	8.10	5.40	13.71	0.00	0.00	0.00	0.00	0.00	0.00	0.00	0.00	0.00	0.00
9.06 4.65	584.54	47.36	10.87	10.87	7.24	18.39	0.00	0.00	0.00	0.00	0.00	0.00	0.00	0.00	0.00	0.00
4.65 2.42	502.70	-81.84	-15.67	-15.67	-15.67	-19.89	-8.54	-5.26	-0.68	-0.46	0.00	0.00	0.00	0.00	0.00	0.00
2.42 -1.00	517.20	14.50	2.78	2.78	2.78	3.52	1.51	0.93	0.12	0.08	0.00	0.00	0.00	0.00	0.00	0.00
-1.00 -2.75	310.39	-206.81	-39.16	-39.16	-39.16	-49.71	-21.35	-13.14	-1.71	-3.44	0.00	0.00	0.00	0.00	0.00	0.00
-2.75 -6.40	310.71	0.33	0.06	0.06	0.06	0.08	0.03	0.02	0.00	0.01	0.00	0.00	0.00	0.00	0.00	0.00
-6.40 -11.50	277.96	-32.75	-7.34	-7.34	-7.34	-9.32	6.65	-2.46	-0.64	-0.66	-0.43	-0.49	-0.53	-0.66	-0.94	-0.94
-11.50 -15.50	---	181.62														

Note

*1: The difference between the modeled elevation 52.4 m and the actual elevation 52.7 m at the RB roof is negligibly small.



Table 6.2.3.9-6 Applied Overturning Moment – RBFB X(N-S)-dir.

Elev. (m)	Model Elev. (m)	Story Height (m)	Node No.	RBFB Moment (X-dir.)								
				M (MNm)	moment Mq (MNm)	M-Mq (MNm)	dM (MNm)	m (MNm)	Diff. (m)	dMq (MNm)	m+dMq (MNm)	
*52.40	52.05	18.05	110	2.724E+03	0.000E+00	2.724E+03	2.724E+03	2.724E+03	2.724E+03	0.05	9.61	2.734E+03
34.00			109	5.838E+03	3.527E+03	2.311E+03						
34.00	34.00	8.20	109	8.196E+03	3.527E+03	4.669E+03	4.669E+03	4.669E+03	1.945E+03	0.00	0.00	1.945E+03
27.00			108	8.719E+03	4.947E+03	3.772E+03						
27.00	25.80	3.30	108	9.400E+03	4.947E+03	4.453E+03	4.453E+03	4.453E+03	-2.154E+02	1.20	267.38	5.199E+01
22.50			107	9.599E+03	6.254E+03	3.345E+03						
22.50	22.50	5.30	107	1.122E+04	6.254E+03	4.963E+03	4.963E+03	4.963E+03	5.093E+02	0.00	0.00	5.093E+02
17.50			106	1.142E+04	8.567E+03	2.857E+03						
17.50	17.20	4.13	106	1.210E+04	8.567E+03	3.538E+03	3.538E+03	3.538E+03	-1.424E+03	0.30	0.62	-1.424E+03
13.57			105	1.235E+04	1.038E+04	1.971E+03						
13.57	13.07	4.51	105	1.284E+04	1.038E+04	2.461E+03	2.461E+03	2.461E+03	-1.077E+03	0.50	6.14	-1.071E+03
9.06			104	1.365E+04	1.241E+04	1.241E+03						
9.06	8.56	4.91	104	1.390E+04	1.241E+04	1.494E+03	1.494E+03	1.494E+03	-9.670E+02	0.50	1.95	-9.651E+02
4.65			103	1.523E+04	1.464E+04	5.885E+02						
4.65	3.65	5.15	103	9.392E+03	1.464E+04	-5.250E+03	-5.250E+03	-5.250E+03	-6.745E+03	1.00	0.06	-6.745E+03
-1.00			102	1.095E+04	1.698E+04	-6.032E+03						
-1.00	-1.50	5.40	102	6.545E+03	1.698E+04	-1.044E+04	-1.044E+04	-1.044E+04	-5.189E+03	0.50	-107.34	-5.296E+03
-6.40			101	7.303E+03	1.828E+04	-1.098E+04						
-6.40	-6.90	4.60	101	4.748E+03	1.828E+04	-1.353E+04	-1.353E+04	-1.353E+04	-3.093E+03	0.50	-1.16	-3.094E+03
-11.50			2	5.053E+03	1.937E+04	-1.432E+04						
-11.50	-11.50	2.00	2									1.177E+03
-15.50			1									

General Note: Q: Design Shear Force dM: Additional Moment
M: Design Moment m: Input Moment
Mq: Moment due to Shear dMq: Moment Modification Considering to the Difference of the Input Level

Note

*1: The difference between the modeled elevation 52.4 m and the actual elevation 52.7 m at the RB roof is negligibly small.



Table 6.2.3.9-7 Applied Overturning Moment – RBFY Y(E-W)-dir.

Elev. (m)	Model Elev. (m)	Story Height (m)	Node No.	RBFY Moment (Y-dir.)								
				M (MNm)	moment Mq (MNm)	M-Mq (MNm)	dM (MNm)	m (MNm)	Diff. (m)	dMq (MNm)	m+dMq (MNm)	
*52.40	52.05	18.05	110	2.143E+03	0.000E+00	2.143E+03	2.143E+03	2.143E+03	2.143E+03	0.05	7.00	2.150E+03
34.00			109	4.488E+03	2.568E+03	1.919E+03						
34.00	34.00	8.20	109	5.821E+03	2.568E+03	3.253E+03	3.253E+03	3.253E+03	1.110E+03	0.00	0.00	1.110E+03
27.00			108	6.389E+03	3.503E+03	2.887E+03						
27.00	25.80	3.30	108	7.162E+03	3.503E+03	3.659E+03	3.659E+03	3.659E+03	4.060E+02	1.20	174.56	5.806E+02
22.50			107	7.958E+03	4.359E+03	3.599E+03						
22.50	22.50	5.30	107	8.328E+03	4.359E+03	3.969E+03	3.969E+03	3.969E+03	3.100E+02	0.00	0.00	3.100E+02
17.50			106	9.227E+03	5.906E+03	3.322E+03						
17.50	17.20	4.13	106	9.408E+03	5.906E+03	3.502E+03	3.502E+03	3.502E+03	-4.667E+02	0.30	15.50	-4.512E+02
13.57			105	1.020E+04	7.324E+03	2.871E+03						
13.57	13.07	4.51	105	1.026E+04	7.324E+03	2.931E+03	2.931E+03	2.931E+03	-5.710E+02	0.50	10.11	-5.608E+02
9.06			104	1.122E+04	8.965E+03	2.251E+03						
9.06	8.56	4.91	104	1.134E+04	8.965E+03	2.373E+03	2.373E+03	2.373E+03	-5.581E+02	0.50	9.81	-5.482E+02
4.65			103	1.251E+04	1.085E+04	1.659E+03						
4.65	3.65	5.15	103	6.302E+03	1.085E+04	-4.545E+03	-4.545E+03	-4.545E+03	-6.918E+03	1.00	-23.26	-6.941E+03
-1.00			102	7.759E+03	1.270E+04	-4.943E+03						
-1.00	-1.50	5.40	102	4.819E+03	1.270E+04	-7.883E+03	-7.883E+03	-7.883E+03	-3.338E+03	0.50	-66.76	-3.404E+03
-6.40			101	5.358E+03	1.393E+04	-8.567E+03						
-6.40	-6.90	4.60	101	3.351E+03	1.393E+04	-1.057E+04	-1.057E+04	-1.057E+04	-2.692E+03	0.50	-13.07	-2.705E+03
-11.50			2	3.356E+03	1.485E+04	-1.149E+04						
-11.50	-11.50	2.00	2									1.057E+03
-15.50			1									

General Note: Q: Design Shear Force dM: Additional Moment
M: Design Moment m: Input Moment
Mq: Moment due to Shear dMq: Moment Modification Considering to the Difference of the Input Level

Note

*1: The difference between the modeled elevation 52.4 m and the actual elevation 52.7 m at the RB roof is negligibly small.



Table 6.2.3.9-8 Applied Overturning Moment – RCCV X(N-S)-dir.

Elev. (m)	Model Elev. (m)	Story Height (m)	Node No.	RCCV Moment (X-dir.)							
				M (MNm)	moment Mq (MNm)	M-Mq (MNm)	dM (MNm)	m (MNm)	Diff. (m)	dMq (MNm)	m+dMq (MNm)
34.00	34.00	8.20	209	2.298E+02	0.000E+00	2.298E+02	2.298E+02	2.298E+02	0.00	0.00	2.298E+02
27.00			208	1.029E+03	1.074E+03	-4.460E+01					
27.00	25.80	8.60	208	2.162E+03	1.074E+03	1.088E+03	1.088E+03	8.580E+02	1.20	12.16	8.702E+02
17.50			206	2.938E+03	2.287E+03	6.509E+02					
17.50	17.20	4.13	206	3.259E+03	2.287E+03	9.719E+02	9.719E+02	-1.160E+02	0.30	12.92	-1.030E+02
13.57			205	3.691E+03	3.047E+03	6.433E+02					
13.57	13.07	4.51	205	3.817E+03	3.047E+03	7.700E+02	7.700E+02	-2.019E+02	0.50	11.88	-1.900E+02
9.06			204	4.389E+03	3.985E+03	4.037E+02					
9.06	8.56	4.91	204	4.481E+03	3.985E+03	4.961E+02	4.961E+02	-2.739E+02	0.50	8.74	-2.652E+02
4.65			203	5.190E+03	5.092E+03	9.850E+01					
4.65	3.65	5.15	203	5.523E+03	5.092E+03	4.315E+02	4.315E+02	-6.453E+01	1.00	-116.19	-1.807E+02
-1.00			202	5.740E+03	5.654E+03	8.605E+01					
-1.00	-1.50	5.40	202	6.008E+03	5.654E+03	3.536E+02	3.536E+02	-7.796E+01	0.50	-20.78	-9.874E+01
-6.40			201	5.924E+03	6.019E+03	-9.560E+01					
-6.40	-6.90	4.60	201	6.053E+03	6.019E+03	3.359E+01	3.359E+01	-3.200E+02	0.50	1.55	-3.184E+02
-11.50			2	5.961E+03	6.345E+03	-3.837E+02					

Note: Q: Design Shear Force dM: Additional Moment
M: Design Moment m: Input Moment
Mq: Moment due to Shear dMq: Moment Modification Considering to the Difference of the Input Level



Table 6.2.3.9-9 Applied Overturning Moment – RCCV Y(E-W)-dir.

Elev. (m)	Model Elev. (m)	Story Height (m)	Node No.	RCCV Moment (Y-dir.)								
				M (MNm)	moment Mq (MNm)	M-Mq (MNm)	dM (MNm)	m (MNm)	Diff. (m)	dMq (MNm)	m+dMq (MNm)	
34.00	34.00	8.20	209	5.097E+02	0.000E+00	5.097E+02	5.097E+02	5.097E+02	0.00	0.00	5.097E+02	
27.00			208	1.160E+03	1.093E+03	6.738E+01						
27.00	25.80	8.60	208	2.303E+03	1.093E+03	1.210E+03	1.210E+03	7.004E+02	1.20	22.36	7.228E+02	
17.50			206	3.071E+03	2.399E+03	6.722E+02						
17.50	17.20	4.13	206	3.667E+03	2.399E+03	1.268E+03	1.268E+03	5.806E+01	0.30	1.95	6.001E+01	
13.57			205	3.904E+03	3.053E+03	8.512E+02						
13.57	13.07	4.51	205	4.203E+03	3.053E+03	1.150E+03	1.150E+03	-1.181E+02	0.50	7.54	-1.105E+02	
9.06			204	4.491E+03	3.835E+03	6.557E+02						
9.06	8.56	4.91	204	4.853E+03	3.835E+03	1.018E+03	1.018E+03	-1.318E+02	0.50	13.87	-1.179E+02	
4.65			203	5.203E+03	4.823E+03	3.799E+02						
4.65	3.65	5.15	203	5.470E+03	4.823E+03	6.472E+02	6.472E+02	-3.711E+02	1.00	-75.48	-4.466E+02	
-1.00			202	5.824E+03	5.470E+03	3.541E+02						
-1.00	-1.50	5.40	202	6.066E+03	5.470E+03	5.962E+02	5.962E+02	-5.097E+01	0.50	-28.81	-7.978E+01	
-6.40			201	6.035E+03	5.838E+03	1.973E+02						
-6.40	-6.90	4.60	201	6.141E+03	5.838E+03	3.037E+02	3.037E+02	-2.925E+02	0.50	-6.47	-2.989E+02	
-11.50			2	6.127E+03	6.091E+03	3.594E+01						

Note: Q: Design Shear Force dM: Additional Moment
M: Design Moment m: Input Moment
Mq: Moment due to Shear dMq: Moment Modification Considering to the Difference of the Input Level



HITACHI

WG3-U71-ERD-S-0004	SH NO. 150
REV. 0	of 538

Table 6.2.3.9-10 Applied Overturning Moment – RPV Pedestal X(N-S)-dir.

Elev. (m)	Model Elev. (m)	Story Height (m)	Node No.	Pedestal Moment (X-dir.)							
				M (MNm)	moment Mq (MNm)	M-Mq (MNm)	dM (MNm)	m (MNm)	Diff. (m)	dMq (MNm)	m+dMq (MNm)
4.65	3.65	1.00	303	6.670E+02	0.000E+00	6.670E+02	6.670E+02	6.670E+02	1.00	20.55	6.876E+02
2.42			377	6.508E+02	4.589E+01	6.049E+02					
2.42	2.65	4.15	377	7.931E+02	4.589E+01	7.472E+02	7.472E+02	8.017E+01	0.23	2.65	8.281E+01
-1.00			302	7.541E+02	1.554E+02	5.987E+02					
-1.00	-1.50	1.80	302	6.913E+02	1.554E+02	5.359E+02	5.359E+02	-2.113E+02	0.50	-4.97	-2.162E+02
-2.75			376	6.581E+02	1.942E+02	4.639E+02					
-2.75	-3.30	3.60	376	6.580E+02	1.942E+02	4.638E+02	4.638E+02	-7.210E+01	0.55	-0.20	-7.230E+01
-6.40			301	5.943E+02	2.735E+02	3.208E+02					
-6.40	-6.90	4.60	301	5.553E+02	2.735E+02	2.818E+02	2.818E+02	-1.820E+02	0.50	4.03	-1.780E+02
-11.50			2	5.535E+02	4.256E+02	1.279E+02					

Note: Q: Design Shear Force dM: Additional Moment
M: Design Moment m: Input Moment
Mq: Moment due to Shear dMq: Moment Modification Considering to the Difference of the Input Level



HITACHI

WG3-U71-ERD-S-0004 SH NO. 151
REV. 0 of 538

Table 6.2.3.9-11 Applied Overturning Moment – RPV Pedestal Y(E-W)-dir.

Elev. (m)	Model Elev. (m)	Story Height (m)	Node No.	Pedestal Moment (Y-dir.)							
				M (MNm)	moment Mq (MNm)	M-Mq (MNm)	dM (MNm)	m (MNm)	Diff. (m)	dMq (MNm)	m+dMq (MNm)
4.65	3.65	1.00	303	4.962E+02	0.000E+00	4.962E+02	4.962E+02	4.962E+02	1.00	16.90	5.131E+02
2.42			377	5.021E+02	3.774E+01	4.644E+02					
2.42	2.65	4.15	377	6.139E+02	3.774E+01	5.761E+02	5.761E+02	7.997E+01	0.23	7.22	8.719E+01
-1.00			302	6.309E+02	1.450E+02	4.859E+02					
-1.00	-1.50	1.80	302	5.706E+02	1.450E+02	4.256E+02	4.256E+02	-1.505E+02	0.50	7.86	-1.427E+02
-2.75			376	5.551E+02	1.726E+02	3.825E+02					
-2.75	-3.30	3.60	376	5.551E+02	1.726E+02	3.825E+02	3.825E+02	-4.306E+01	0.55	8.83	-3.423E+01
-6.40			301	5.244E+02	2.311E+02	2.933E+02					
-6.40	-6.90	4.60	301	5.184E+02	2.311E+02	2.873E+02	2.873E+02	-9.526E+01	0.50	11.19	-8.407E+01
-11.50			2	5.137E+02	3.453E+02	1.684E+02					

Note: Q: Design Shear Force dM: Additional Moment
M: Design Moment m: Input Moment
Mq: Moment due to Shear dMq: Moment Modification Considering to the Difference of the Input Level



HITACHI

WG3-U71-ERD-S-0004 SH NO. 152
REV. 0 of 538

Table 6.2.3.9-12 Design Vertical Acceleration for Slabs

EL (m)	Node	Weight sW_i (kN)	Oscillator Acceleration sA_i (g)	$sA_{eq} \times sW_i$ (kN-g)	sA_{eq} (g)	Slab Weight W_{SI} (kN)				$W_{SI} - \Sigma sW_i$ (kN)				Seismic Analysis Results			Applied Acc. (g)	Portion
						RRB/FB		RCCV	Pedestal	RRB/FB		RCCV	Pedestal	Z-dir. Acceleration (g)				
						RRW	FBW	$RCCVW$	$PEDW$	RRW_s	FBW_s	$RCCV_s$	PED_s	RRB_s	$RCCV_s$	PED_s		
52.4 ¹	9101	29394	0.32	9541	1.51	50695				5180				1.56			1.51	RB Roof
	9102	4406	1.28	5627														
	9103	5859	6.27	36721														
	9104	2726	2.62	7136														
	9105	186	2.42	449														
	9106	1211	3.52	4265														
	9107	824	3.22	2650														
	9108	909	2.50	2275														
34.00	9091	4918	1.61	7938	1.61	30344		40678		27885		29053		1.20	1.20		1.23	RB-RCCV
	9092	9165	1.61	14731	1.61												1.30	RCCV
27.00	9081	39043	1.60	62331	1.55	61551	18448	171322		48004	18448	69949		1.02	1.12		1.37	Top Slab
	9082	52533	1.52	79714														
	9083	8768	1.30	11392	1.30												1.06	RB-RCCV
	9084	9163	1.67	15334	1.67												1.13	M/S tunnel roof
	9085	5413	1.46	7910														
22.50	9071	20024	1.15	22991	1.34		30394				2345			0.92			1.31	FB Roof
	9072	2679	1.64	4404														
	9073	707	4.47	3156														
	9074	3442	1.53	5283														
	9075	1196	1.51	1809														
17.50	9061	5798	3.65	21166	3.40	26787		52884		12732		46092		0.80	0.91		1.74	M/S tunnel slab
	9062	1465	2.40	3523													0.94	RB-RCCV
	9063	9707	1.13	11017	1.18													
	9064	37619	2.56	96235	2.38													
	9065	3877	1.28	4975														
	99064	4884	0.99	4817														
13.57	9051	10042	1.11	11167	1.15	26268	1295	16342		19081	1295	9154		0.72	0.82		0.89	RB-RCCV
	9052	4333	1.25	5420														
9.06	9041	11090	0.95	10531	1.04	28298		16069		20346		8117		0.62	0.72		0.79	RB-RCCV
	9042	4816	1.26	6054														
4.65	9031	11025	1.62	17900	1.66	25975	32624	56614	64383		16193	11812	48175	0.56	0.65	0.65	1.11	FB
	9032	51608	0.89	46093	0.91												0.87	RB-RCCV
	9033	32416	1.12	36403	1.12												0.82	RCCV-Pedestal
	9034	5407	1.73	9346														
	9035	5579	1.07	5966														
-1.00	9021	3655	0.97	3531	1.25	27955	37426	23803	16700	20115	29902	8894	9631	0.57	0.58	0.59	0.71	FB
	9022	1086	1.90	2065														
	9023	10996	0.98	10733	1.03												0.73	RB-RCCV
	9024	5993	0.85	5107	0.87												0.72	RCCV-Pedestal
	9025	4685	1.14	5341														
	9026	2783	1.38	3832														
	9027	8144	0.89	7243														
-6.40	9011	3704	0.73	2705	0.80	29797	40864	23914	14176	22680	37488	13133	10513	0.53	0.55	0.56	0.61	RCCV-Pedestal
	9012	3622	0.87	3155														
	9013	4424	0.91	4012	0.99												0.66	RB-RCCV
	9014	3377	1.12	3773	1.12												0.58	FB
	9015	9811	1.03	10115														

Note

*1: The difference between the modeled elevation 52.4 m and the actual elevation 52.7 m at the RB roof is negligibly small.



Table 6.2.3.9-13 Applied Shear Forces for Seismic Wall due to Torsional Moment

Elevation (m)	Center of Rigid		Design Shear Force (MN)	Torsion due to Shear Force <i>T_s</i> (MNm)	Design Torsion <i>T</i> (MNm)	<i>T-T_s</i> (MNm)	Applied Torsion (MNm)							
	Rx (m)	Ry (m)												
52.40 ^{*1} 34.00	23.50	24.44	139.97		1754.7	1754.7	1754.7	Torsion (MNm)	RA	446.5			R1	430.8
									RG	446.5			R7	430.8
34.00 27.00	23.50	23.50	247.18	0.0	2839.6	2839.6	1085.0	Area (m ²)	RA	49.0	PG	59.2	R1	49.0
									RG	49.0	PG	59.2	R7	49.0
								Rot. Stiff. (m ⁴)	RA	27060.3	PG	2818.5	R1	27060.3
									RG	27060.3	PG	2818.5	R7	27060.3
								Torsion (MNm)	RA	257.8	PG	26.9	R1	257.8
									RG	257.8	PG	26.9	R7	257.8
27.00 22.50	25.76	23.50	411.28	559.4	5977.6	5418.1	2578.5	Area (m ²)	RA	73.5			R1	50.1
									RG	73.5			R7	73.5
								Rot. Stiff. (m ⁴)	RA	40596.0	RCCV	86149.0	R1	33253.5
									RG	40584.7	RCCV Y	241.2	R7	33148.6
								Torsion (MNm)	RA	447.4	RCCV	949.4	R1	366.5
									RG	447.3	RCCV Y	2.7	R7	365.3
22.50 17.50	33.18	23.98	443.71	3610.2	7997.4	4387.2	-1030.9	Area (m ²)	RA	92.2			R1	48.4
									RG	90.1			R7	73.5
													F3	48.6
								Rot. Stiff. (m ⁴)	RA	48844.3	RCCV	86149.0	R1	56535.6
									RG	51831.2	RCCV Y	11182.6	R7	14036.1
											RCCV X	28.0	F3	65816.7
								Torsion (MNm)	RA	-150.6	RCCV	-265.6	R1	-174.3
									RG	-159.8	RCCV Y	-34.5	R7	-43.3
											RCCV X	-0.1	F3	-202.9

Note

*1: The difference between the modeled elevation 52.4 m and the actual elevation 52.7 m at the RB roof is negligibly small.



HITACHI

WG3-U71-ERD-S-0004

SH NO. 154

REV. 0

of 538

Table 6.2.3.9-13 Applied Shear Forces for Seismic Wall due to Torsional Moment (Continued)

Elevation (m)	Center of Rigid		Design Shear Force (MN)	Torsion due to Shear Force <i>T_s</i> (MNm)	Design Torsion <i>T</i> (MNm)	<i>T-T_s</i> (MNm)	Applied Torsion (MNm)									
	Rx (m)	Ry (m)						Area (m ²)	RA	RG	RCCV	RCCV Y	RCCV X	R1	R7	F3
17.50 13.57	30.49	23.99	501.87	2416.9	7516.9	5099.9	712.7	Area (m ²)	RA 92.2	RG 90.1			R1 73.5	R7 73.5	F3 49.0	
								Rot. Stiff. (m ⁴)	RA 48837.5	RG 51838.1	RCCV 86149.0	RCCV Y 5832.7	RCCV X 28.2	R1 68335.7	R7 20030.7	F3 68937.1
								Torsion (MNm)	RA 99.4	RG 105.6	RCCV 175.4	RCCV Y 11.9	RCCV X 0.1	R1 139.2	R7 40.8	F3 140.4
13.57 9.06	30.49	23.82	537.18	2416.9	7966.1	5549.2	449.2	Area (m ²)	RA 92.2	RG 92.2			R1 73.5	R7 73.5	F3 49.0	
								Rot. Stiff. (m ⁴)	RA 49547.3	RG 52317.5	RCCV 86149.0	RCCV Y 5832.6	RCCV X 12.2	R1 68335.5	R7 20030.9	F3 68937.3
								Torsion (MNm)	RA 63.4	RG 66.9	RCCV 110.2	RCCV Y 7.5	RCCV X 0.0	R1 87.4	R7 25.6	F3 88.2
9.06 4.65	31.00	24.23	584.54	2690.1	8798.2	6108.1	558.9	Area (m ²)	RA 90.8	RG 88.9			R1 69.4	R7 73.5	F3 47.9	
								Rot. Stiff. (m ⁴)	RA 47067.7	RG 52178.6	RCCV 86149.0	RCCV Y 6711.9	RCCV X 64.2	R1 66693.8	R7 18815.8	F3 65615.8
								Torsion (MNm)	RA 76.6	RG 84.9	RCCV 140.3	RCCV Y 10.9	RCCV X 0.1	R1 108.6	R7 30.6	F3 106.8



HITACHI

WG3-U71-ERD-S-0004 SH NO. 155
REV. 0 of 538

Table 6.2.3.9-13 Applied Shear Forces for Seismic Wall due to Torsional Moment (Continued)

Elevation (m)	Center of Rigid		Design Shear Force (MN)	Torsion due to Shear Force Ts (MNm)	Design Torsion T (MNm)	T-Ts (MNm)	Applied Torsion (MNm)								
	Rx (m)	Ry (m)						Area (m ²)	RA	RG	RCCV	pede	R1	R7	F3
4.65 -1.00	36.41	24.21	502.70	5851.0	8617.3	2766.3	-3341.8	163.3	154.0				98.0	137.8	125.1
								84805.4	90273.1	RCCV	86149.0	pede	4739.1	R1	129900.4
										RCCV Y	19879.5	pede Y	8537.7	R7	15464.4
										RCCV X	60.4	pede X	25.9	F3	124889.6
								-501.8	-534.2	RCCV	-509.8	pede	-28.0	R1	-768.7
										RCCV Y	-117.6	pede Y	-50.5	R7	-91.5
										RCCV X	-0.4	pede X	-0.2	F3	0.0
-1.00 -6.40	36.67	24.29	310.39	5981.7	4436.6	-1545.2	-4311.4	160.4	151.6					R1	98.0
								82738.2	89427.1	RCCV	86149.0	pede	4739.1	R7	140.6
										RCCV Y	20688.6	pede Y	8885.2	F3	132.5
										RCCV X	73.9	pede X	31.7	R1	131762.7
								-626.3	-676.9	RCCV	-652.1	pede	-35.9	R7	15004.7
										RCCV Y	-156.6	pede Y	-67.3	F3	130106.7
										RCCV X	-0.6	pede X	-0.2	R1	-997.3
										pede	-35.9			R7	-113.6
										pede Y	-67.3			F3	0.0
										pede X	-0.2				



Table 6.2.3.9-15 Design Acceleration for Seismic Walls

EL (m)	Node	Weight W_i (kN)	Oscillator Acceleration A_i (g)	$W_i \times A_i$ (kN·g)	A_{eq} (g)	$A_{eq} \times W_i$ (kN·g)	Wall Weight W_b (kN)	Seismic Analysis Results A_b (g)	$A_b \times W_b$ (kN·g)	Applied Acc. A_{ave} (g)	Portion
42	99981	8.13	2.66	21.61	2.59	22.45	7.58	1.54	11.69	2.1	R1 and R7 walls
	99982	0.54	1.54	0.84							
	99986	0	0	0							
	99983	4.56	1.86	8.48	1.34	15.94	8.48	1.18	9.97	1.27	RB and RF walls
	99984	5.1	1.02	5.19							
	99985	2.28	1	2.27							
99987	0	0	0								
30.5	99991	3.51	0.58	2.03	0.58	2.03	3.11	0.59	1.82	0.58	R1 and R7 walls
	99992	4.77	0.56	2.67	0.56	2.67	1.65	0.48	0.8	0.54	RA and RG walls
13.57	99971	8.09	2.11	17.04	2.05	22.33	8.87	0.79	6.98	1.48	F3 wall
	99972	2.38	2	4.75							
	99973	0.23	1.35	0.31							
	99974	0.21	1.04	0.22							
	99977	0	0	0							
	99975	4.93	2.16	10.66	1.98	11.44	2.69	0.62	1.67	1.55	FA and FF walls
	99976	0.86	0.92	0.79							
	99978	0	0	0							



Table 6.2.4-1 Results of NASTRAN Analysis, Dead Load

Table with 10 columns: Location, Element ID, Nx (MN/m), Ny (MN/m), Nxy (MN/m), Mx (MNm/m), My (MNm/m), Mxy (MNm/m), Qx (MN/m), Qy (MN/m). Rows include various structural elements like walls, slabs, and basemat with their corresponding element IDs and force/moment values.

SI to U.S. Customary units conversion (SI units are the controlling units and U.S. Customary units are for reference only): 1 MN/m = 6.852x10^4 lbf/ft, 1 MNm/m = 2.248x10^5 lbf-ft/ft

**Table 6.2.4-2 Results of NASTRAN Analysis, Drywell Unit Pressure (1 MPa)**

Location	Element ID	Nx (MN/m)	Ny (MN/m)	Nxy (MN/m)	Mx (MNm/m)	My (MNm/m)	Mxy (MNm/m)	Qx (MN/m)	Qy (MN/m)
18 Wall Below RCCV Bottom	6	-0.782	3.081	-0.494	0.535	3.112	-0.009	0.024	1.037
	13	-0.601	2.839	-0.131	0.565	3.223	-0.001	-0.001	1.001
	24	-0.965	3.199	0.063	0.600	3.410	-0.006	0.005	1.062
19 Wall Below RCCV Mid-Height	806	0.141	3.210	-0.420	-0.006	0.034	0.012	-0.010	0.098
	813	0.210	2.625	-0.115	-0.004	0.035	0.006	0.025	0.187
	824	0.073	3.362	0.087	0.025	-0.023	0.004	-0.001	0.177
20 Wall Below RCCV Top	1606	0.820	3.176	-0.445	-0.313	-1.804	0.002	0.000	0.507
	1613	0.808	2.321	-0.087	-0.315	-1.779	-0.004	-0.001	0.534
	1624	0.893	3.579	0.049	-0.315	-1.982	-0.003	0.003	0.588
21 Exterior Wall @ EL-11.50 ~-10.50m	20011	0.071	0.558	0.035	0.201	0.718	0.015	-0.013	0.211
	20023	0.012	-0.084	-0.112	-0.052	0.030	-0.003	-0.001	0.016
	30010	0.281	-0.185	-0.032	0.275	1.324	-0.013	-0.002	-0.276
	30020	0.101	-0.299	-0.038	-0.094	0.015	0.028	0.036	0.004
	40001	0.048	-0.243	0.191	-0.084	0.093	-0.015	-0.008	-0.014
22 Exterior Wall @ EL4.65 ~6.60m	40011	-0.173	0.038	-0.025	0.312	1.502	0.011	-0.001	-0.323
	22011	0.051	0.628	-0.101	0.009	0.001	0.005	0.004	-0.144
	22023	-0.005	-0.271	-0.117	-0.003	0.025	-0.005	0.017	-0.006
	32010	0.202	0.007	0.008	0.011	0.089	0.002	0.000	0.055
	32020	0.014	-0.482	0.395	0.014	0.036	-0.008	-0.005	0.026
23 Exterior Wall @ EL22.50 ~24.60m	42001	-0.016	-0.401	0.432	0.013	0.028	-0.009	0.000	0.000
	42011	0.028	0.846	-0.056	0.019	0.010	0.008	-0.004	0.085
	24211	0.887	0.469	-0.039	0.164	0.924	0.022	0.021	-0.547
	24224	0.026	-1.421	-0.355	-0.009	0.166	0.068	0.112	0.106
	34210	0.867	-0.063	0.043	-0.017	0.218	0.014	-0.009	0.108
24 Basemat @ Wall Below RCCV	34220	0.082	-1.253	0.474	0.009	0.116	0.022	0.010	-0.007
	44201	0.015	-0.962	0.694	0.044	0.080	-0.024	0.002	-0.011
	90140	-0.184	0.372	0.811	3.065	2.483	-3.410	0.372	-0.663
	90182	1.621	0.055	-0.077	-0.815	4.523	0.451	-0.086	-0.661
25 Slab EL4.65m @ RCCV	90111	0.105	0.741	-0.115	4.496	-0.686	0.507	-0.674	-0.062
	93140	-0.061	0.033	0.040	0.089	0.062	-0.063	0.015	-0.018
	93182	0.102	-0.076	0.023	0.000	0.105	0.006	-0.001	-0.009
26 Slab EL17.5m @ RCCV	93111	-0.082	0.016	0.009	0.139	0.008	0.004	-0.040	-0.002
	96144	0.344	0.356	1.139	0.212	0.292	-0.200	0.047	-0.091
	96186	1.151	-0.565	0.134	0.037	0.398	-0.057	0.014	-0.184
27 Slab EL27.0m @ RCCV	96113	-0.707	1.224	0.310	2.177	0.197	-0.345	-0.896	-0.091
	98472	0.163	0.996	-0.907	-0.605	-0.974	1.234	-0.362	0.445
	98514	0.037	0.075	-0.055	-0.199	-1.790	-0.112	0.035	0.525
28 Pool Girder @ Storage Pool	98424	-0.651	2.174	-0.117	-5.122	-0.748	-0.373	1.644	0.136
	123054	-0.702	7.558	5.501	0.029	-0.028	-0.463	-0.088	-0.117
29 Pool Girder @ Cavity	123154	-2.824	1.013	4.826	-0.013	0.047	-0.605	-0.224	0.053
	123062	-0.641	-4.572	-3.810	0.138	1.124	-0.031	0.036	0.525
30 Pool Girder @ Fuel Pool	123162	8.026	-1.931	-2.543	0.323	0.246	-0.048	-0.321	-0.086
	123067	-0.860	8.105	-7.114	-0.065	0.021	0.320	0.259	-0.060
31 MS Tunnel Wall and Slab	123167	-2.176	1.703	-6.458	-0.046	-0.082	0.022	0.061	0.053
	150122	0.128	-0.669	0.201	-0.004	0.075	-0.012	0.009	-0.068
	96611	-0.032	0.635	-0.024	-0.062	-0.109	-0.020	0.021	0.008
	98614	0.000	-0.192	-0.002	-0.459	-1.034	-0.154	0.139	0.047
32 IC/PCCS Pool Wall in NS Direction	125051	0.631	4.482	4.339	-0.082	0.227	0.008	-0.073	0.187
	125151	0.945	1.262	3.557	-0.093	0.031	0.016	-0.146	0.023
	125055	0.099	-0.466	-0.041	0.109	0.530	-0.005	0.174	0.329
	125155	2.945	-0.386	-0.013	-0.014	-0.143	-0.026	-0.195	0.216

SI to U.S. Customary units conversion (SI units are the controlling units and U.S. Customary units are for reference only): $1 \text{ MN/m} = 6.852 \times 10^4 \text{ lbf/ft}$, $1 \text{ MNm/m} = 2.248 \times 10^5 \text{ lbf-ft/ft}$

**Table 6.2.4-3 Results of NASTRAN Analysis, Wetwell Unit Pressure (1 MPa)**

Location	Element ID	Nx (MN/m)	Ny (MN/m)	Nxy (MN/m)	Mx (MNm/m)	My (MNm/m)	Mxy (MNm/m)	Qx (MN/m)	Qy (MN/m)
18 Wall Below RCCV Bottom	6	-0.252	0.171	-0.090	0.107	0.648	-0.004	0.008	0.198
	13	-0.231	-0.049	-0.048	0.134	0.745	0.000	0.001	0.225
	24	-0.284	-0.077	0.037	0.137	0.774	-0.001	0.001	0.234
19 Wall Below RCCV Mid-Height	806	0.144	0.122	0.017	0.041	0.233	0.012	0.001	-0.018
	813	0.188	-0.091	-0.016	0.066	0.252	0.004	0.003	0.018
	824	0.162	-0.098	0.038	0.047	0.251	0.000	-0.001	0.026
20 Wall Below RCCV Top	1606	1.578	0.058	0.000	-0.455	-2.620	0.000	0.002	0.845
	1613	1.551	-0.214	-0.015	-0.469	-2.690	-0.005	-0.002	0.913
	1624	1.738	-0.224	0.026	-0.492	-2.731	0.008	-0.001	0.940
21 Exterior Wall @ EL-11.50 ~10.50m	20011	0.139	0.542	0.021	0.087	0.330	0.007	-0.021	0.109
	20023	0.002	-0.001	-0.013	-0.026	0.041	0.000	0.014	0.020
	30010	0.185	0.328	0.000	0.104	0.555	-0.003	-0.002	-0.118
	30020	0.026	-0.146	-0.025	-0.046	0.045	0.013	0.002	-0.008
	40001	0.017	-0.134	0.055	-0.046	0.061	-0.010	0.002	-0.013
	40011	0.133	0.364	0.023	0.110	0.594	0.003	0.002	-0.129
22 Exterior Wall @ EL4.65 ~6.60m	22011	0.988	0.301	-0.104	-0.002	0.136	0.004	-0.015	0.312
	22023	0.115	0.355	0.206	0.298	0.060	-0.059	-0.102	-0.014
	32010	1.119	0.199	-0.062	-0.014	0.105	0.016	-0.001	-0.307
	32020	0.107	0.618	0.244	0.221	0.042	-0.106	0.155	0.013
	42001	0.147	0.661	-0.064	0.290	0.042	0.042	-0.106	0.021
	42011	1.034	0.248	0.149	-0.054	0.071	-0.025	0.003	-0.297
23 Exterior Wall @ EL22.50 ~24.60m	24211	0.425	0.464	0.000	0.033	0.221	-0.003	-0.004	-0.012
	24224	0.020	0.310	-0.156	-0.041	-0.048	0.012	0.001	-0.065
	34210	0.478	0.251	0.003	0.029	0.238	-0.017	0.003	0.047
	34220	-0.018	0.123	-0.001	-0.015	0.031	0.013	-0.030	-0.014
	44201	-0.015	0.143	0.110	-0.011	0.023	-0.011	0.030	-0.009
24 Basemat @ Wall Below RCCV	90140	0.072	0.134	0.147	0.029	0.008	-0.426	-0.094	0.014
	90182	0.341	0.108	0.007	-0.319	-0.040	0.060	-0.002	0.295
	90111	0.107	0.259	-0.015	-0.102	-0.332	0.074	0.330	0.006
25 Slab EL4.65m @ RCCV	93140	0.299	0.397	0.346	0.056	0.042	-0.051	0.002	-0.002
	93182	0.688	0.227	-0.055	-0.008	0.079	0.004	0.002	0.074
	93111	0.238	0.671	-0.130	0.058	-0.014	-0.002	0.062	-0.001
26 Slab EL17.5m @ RCCV	96144	-0.055	0.894	0.401	0.037	-0.089	0.044	0.008	0.024
	96186	0.831	-0.319	-0.424	0.017	-0.030	0.075	-0.023	-0.100
	96113	-0.517	1.364	-0.705	-0.862	-0.011	0.377	0.041	0.027
27 Slab EL27.0m @ RCCV	98472	-0.079	0.083	0.373	0.226	0.288	-0.176	0.137	-0.118
	98514	0.179	0.119	0.007	0.049	0.379	0.009	-0.004	-0.230
	98424	0.106	0.447	0.015	0.431	0.068	0.025	-0.182	-0.014
28 Pool Girder @ Storage Pool	123054	0.151	0.051	-0.045	-0.001	-0.012	0.001	0.017	-0.016
	123154	0.033	0.022	-0.047	0.005	0.007	-0.001	0.006	0.001
29 Pool Girder @ Cavity	123062	0.245	0.035	0.047	-0.010	-0.011	-0.001	0.017	-0.009
	123162	0.168	0.026	0.059	-0.001	0.003	-0.004	0.005	-0.002
30 Pool Girder @ Fuel Pool	123067	0.107	-0.487	-0.009	-0.027	-0.046	-0.017	-0.022	-0.044
	123167	0.251	-0.136	-0.046	0.006	0.008	0.000	-0.012	-0.002
31 MS Tunnel Wall and Slab	150122	0.014	-0.089	-0.006	-0.006	0.019	0.006	0.001	-0.004
	96611	-0.069	0.458	-0.055	0.003	-0.028	0.005	0.001	0.000
	98614	0.007	-0.122	0.005	-0.052	-0.095	-0.020	0.014	0.006
32 IC/PCCS Pool Wall in NS Direction	125051	0.045	-0.153	0.010	-0.009	-0.021	0.001	-0.007	-0.012
	125151	0.022	-0.056	-0.008	-0.006	-0.004	0.000	-0.005	-0.002
	125055	0.158	0.039	0.046	-0.001	-0.006	0.001	0.000	-0.003
	125155	0.067	0.031	0.057	0.001	0.002	0.000	0.002	-0.003

SI to U.S. Customary units conversion (SI units are the controlling units and U.S. Customary units are for reference only): 1 MN/m = 6.852x10⁴ lbf/ft, 1 MNm/m = 2.248x10⁵ lbf-ft/ft



**Table 6.2.4-4 Results of NASTRAN Analysis, Thermal Load
(Normal Operation: Winter)**

(Values obtained from Reference 2.1.2-e)

Location	Element ID	Nx (MN/m)	Ny (MN/m)	Nxy (MN/m)	Mx (MNm/m)	My (MNm/m)	Mxy (MNm/m)	Qx (MN/m)	Qy (MN/m)
18 Wall Below RCCV Bottom	6	1.253	-0.205	-0.568	0.076	0.906	-0.033	0.012	0.034
	13	0.384	-2.513	-0.655	0.359	2.031	-0.003	0.018	0.443
	24	0.608	-2.607	0.109	0.369	2.061	-0.004	-0.001	0.459
19 Wall Below RCCV Mid-Height	806	1.106	-0.949	0.087	0.125	0.770	0.068	-0.045	0.040
	813	0.616	-2.464	-0.504	0.086	0.776	-0.022	0.007	0.463
	824	0.476	-2.699	0.077	0.100	0.784	0.014	0.008	0.416
20 Wall Below RCCV Top	1606	6.930	-1.551	0.139	-0.385	-1.749	0.078	0.068	1.318
	1613	6.711	-2.791	-0.408	-0.489	-2.841	-0.003	-0.010	1.707
	1624	7.196	-3.509	-0.106	-0.548	-2.794	-0.004	-0.051	1.745
21 Exterior Wall @ EL-11.50 ~10.50m	20011	2.857	2.770	0.707	0.218	0.937	0.029	-0.143	0.275
	20023	-1.456	-1.248	1.649	1.953	3.881	0.188	0.289	0.632
	30010	0.135	2.273	-0.121	1.014	3.199	-0.017	-0.023	-0.559
	30020	-0.118	-1.019	-0.219	0.131	1.084	0.109	-0.030	-0.275
	40001	-0.158	-0.676	-0.073	0.169	1.184	-0.072	0.112	-0.307
	40011	0.784	2.397	0.042	1.004	3.271	0.007	0.011	-0.589
22 Exterior Wall @ EL4.65 ~6.60m	22011	1.989	2.366	-0.092	-0.078	-0.066	0.029	0.015	0.113
	22023	1.813	-4.077	-2.023	-0.288	0.359	-0.041	0.709	0.422
	32010	12.350	5.928	0.012	-2.697	-2.528	-0.002	-0.002	-0.174
	32020	0.311	4.027	2.287	-0.573	-1.830	-0.392	0.720	0.111
	42001	2.250	2.855	2.390	-0.736	-1.651	-0.048	-0.662	-0.269
	42011	10.751	3.992	0.063	-2.795	-2.458	0.078	0.067	-0.089
23 Exterior Wall @ EL22.50 ~24.60m	24211	2.843	1.959	-0.374	-0.012	0.038	0.010	-0.116	1.643
	24224	0.119	3.714	-3.310	0.641	-0.241	-0.550	-0.622	-0.226
	34210	13.386	4.447	-0.429	-2.795	-2.685	0.027	-0.009	-0.153
	34220	1.581	3.765	2.292	0.666	-1.618	-0.429	1.495	0.117
	44201	0.865	4.461	-0.102	0.302	-1.803	0.423	-1.817	0.106
24 Basemat @ Wall Below RCCV	90140	1.036	1.410	1.316	1.084	0.020	-1.021	-0.512	-0.135
	90182	1.427	0.428	0.598	-0.072	-3.082	0.173	-0.153	2.372
	90111	0.529	2.358	-0.001	-3.379	-0.412	0.034	2.474	0.116
25 Slab EL4.65m @ RCCV	93140	-0.743	1.592	2.634	-0.402	-0.313	0.220	-0.105	0.085
	93182	2.346	-2.693	-0.779	-0.292	-1.483	-0.064	0.061	1.096
	93111	-2.387	2.996	-0.082	-1.455	-0.268	-0.037	0.959	0.002
26 Slab EL17.5m @ RCCV	96144	0.039	2.670	2.994	-0.152	-0.132	0.104	-0.028	0.043
	96186	2.697	-1.893	-1.089	-0.101	-0.480	-0.033	0.018	0.387
	96113	-4.345	-3.845	-0.732	-3.635	-2.664	-0.140	0.735	-0.030
27 Slab EL27.0m @ RCCV	98472	-0.491	-0.852	4.524	-0.425	-0.142	-0.156	0.325	-0.431
	98514	-0.613	-2.381	-1.036	-0.508	-0.262	-0.053	0.047	-0.171
	98424	-8.688	-9.621	-1.242	0.386	-0.509	0.134	-5.159	-0.068
28 Pool Girder @ Storage Pool	123054	0.578	-3.049	1.386	2.219	2.152	0.031	-0.307	0.546
	123154	0.882	0.664	-0.264	1.850	1.112	-0.331	-0.107	0.233
29 Pool Girder @ Cavity	123062	-2.848	-0.161	-0.520	0.096	0.138	0.035	-0.092	0.076
	123162	-2.548	-0.130	-0.518	0.072	-0.199	0.056	-0.181	0.097
30 Pool Girder @ Fuel Pool	123067	-3.044	-4.728	-1.664	0.540	0.402	-0.076	-0.115	0.516
	123167	-2.836	-2.339	-2.121	0.175	-0.523	-0.229	0.021	0.153
31 MS Tunnel Wall and Slab	150122	0.267	-0.536	1.825	1.079	3.149	-0.033	-0.584	0.414
	96611	-0.243	2.761	-0.171	-1.125	-6.749	-0.368	0.367	0.185
	98614	-0.176	2.269	-0.136	-0.720	-10.191	0.037	0.428	0.285
32 IC/PCCS Pool Wall in NS Direction	125051	-0.451	-0.654	-0.268	-0.001	-0.004	0.000	-0.009	-0.006
	125151	-0.469	-0.568	0.470	0.025	0.055	0.011	-0.018	-0.051
	125055	-1.032	0.211	0.015	0.005	0.025	0.001	0.011	0.010
	125155	-1.349	-0.142	-0.030	0.002	0.027	-0.004	-0.058	0.003

SI to U.S. Customary units conversion (SI units are the controlling units and U.S. Customary units are for reference only): 1 MN/m = 6.852x10⁴ lbf/ft, 1 MNm/m = 2.248x10⁵ lbf-ft/ft



Table 6.2.4-5 Results of NASTRAN Analysis, Thermal Load (LOCA After 6 minutes: Winter)

(Values obtained from Reference 2.1.2-e)

Table with 10 columns: Location, Element ID, Nx (MN/m), Ny (MN/m), Nxy (MN/m), Mx (MNm/m), My (MNm/m), Mxy (MNm/m), Qx (MN/m), Qy (MN/m). Rows include various structural components like walls, slabs, and basemat with their respective element IDs and force/moment values.

SI to U.S. Customary units conversion (SI units are the controlling units and U.S. Customary units are for reference only): 1 MN/m = 6.852x10^4 lbf/ft, 1 MNm/m = 2.248x10^3 lbf-ft/ft



Table 6.2.4-6 Results of NASTRAN Analysis, Thermal Load (LOCA After 72 hours: Winter) – Load Case: TLW8 –

(Values obtained from Reference 2.1.2-e)

Table with 10 columns: Location, Element ID, Nx (MN/m), Ny (MN/m), Nxy (MN/m), Mx (MNm/m), My (MNm/m), Mxy (MNm/m), Qx (MN/m), Qy (MN/m). Rows include various structural components like walls, slabs, and basemat with their respective element IDs and load values.

SI to U.S. Customary units conversion (SI units are the controlling units and U.S. Customary units are for reference only): 1 MN/m = 6.852x10^4 lbf/ft, 1 MNm/m = 2.248x10^5 lbf-ft/ft



Table 6.2.4-7 Results of NASTRAN Analysis, Thermal Load
(LOCA After 72 hours: Winter) – Load Case: TWC1 –

Location	Element ID	Nx (MN/m)	Ny (MN/m)	Nxy (MN/m)	Mx (MNm/m)	My (MNm/m)	Mxy (MNm/m)	Qx (MN/m)	Qy (MN/m)
18 Wall Below RCCV Bottom	6	0.750	-0.853	-0.897	0.196	1.921	-0.057	0.039	0.287
	13	-0.233	-4.144	-0.694	0.618	3.413	0.001	0.024	0.802
	24	-0.151	-3.791	0.237	0.643	3.574	-0.007	-0.003	0.879
19 Wall Below RCCV Mid-Height	806	1.995	-2.239	0.210	0.259	1.574	0.088	-0.079	-0.026
	813	1.447	-4.154	-0.359	0.233	1.691	-0.040	0.005	0.618
	824	1.060	-3.570	0.241	0.222	1.715	0.029	0.014	0.529
20 Wall Below RCCV Top	1606	15.594	-3.429	0.457	-0.786	-3.750	0.141	0.113	2.899
	1613	15.764	-4.938	-0.082	-0.988	-5.556	-0.015	-0.016	3.618
	1624	16.501	-4.321	-0.037	-1.113	-5.449	0.005	-0.111	3.665
21 Exterior Wall @ EL-11.50 ~10.50m	20011	3.641	5.548	1.150	0.472	1.962	0.047	-0.253	0.593
	20023	-3.153	-1.860	2.673	5.515	8.484	0.242	0.308	0.766
	30010	0.485	3.864	-0.425	1.316	4.881	-0.020	-0.034	-0.899
	30020	-0.020	-1.613	-0.431	0.029	1.170	0.143	0.006	-0.261
	40001	-0.060	-1.238	0.166	0.062	1.318	-0.091	0.095	-0.304
	40011	1.097	3.829	0.018	1.284	4.867	0.012	0.014	-0.905
22 Exterior Wall @ EL4.65 ~6.60m	22011	5.314	5.116	-0.168	-0.180	-0.189	0.074	0.040	0.126
	22023	4.072	-3.635	-4.272	-0.152	0.826	0.002	1.198	0.781
	32010	16.767	8.006	-0.288	-2.886	-2.999	-0.015	-0.012	0.019
	32020	0.547	3.903	2.128	0.032	-1.813	-0.337	1.168	0.172
	42001	2.747	2.867	2.337	0.032	-1.567	-0.029	-0.955	-0.229
	42011	15.069	6.132	0.302	-3.149	-2.907	0.066	0.093	0.102
23 Exterior Wall @ EL22.50 ~24.60m	24211	9.506	3.594	-0.774	-0.115	0.134	-0.026	-0.144	2.752
	24224	1.013	6.451	-3.718	2.325	-0.206	-0.927	-2.005	-0.574
	34210	24.186	5.676	-1.247	-2.969	-2.852	0.079	-0.002	-0.199
	34220	3.035	8.365	2.362	3.110	-1.351	-0.641	2.782	0.049
	44201	1.528	9.601	-2.434	2.453	-1.601	0.902	-3.330	0.092
24 Basemat @ Wall Below RCCV	90140	1.320	1.803	1.867	0.019	-1.169	-1.505	-1.060	0.061
	90182	1.721	0.653	0.409	-0.869	-5.630	0.355	-0.061	3.880
	90111	0.761	2.442	0.007	-5.450	-1.106	0.134	3.822	0.151
25 Slab EL4.65m @ RCCV	93140	-0.648	3.031	5.794	-0.772	-0.584	0.424	-0.194	0.167
	93182	6.162	-5.152	-1.674	-0.487	-2.535	-0.107	0.110	1.922
	93111	-4.359	6.745	-0.464	-2.455	-0.425	-0.069	1.657	0.001
26 Slab EL17.5m @ RCCV	96144	1.209	5.959	8.314	-0.377	-0.303	0.253	-0.056	0.120
	96186	10.704	-4.934	-2.716	-0.243	-1.236	-0.072	0.040	1.019
	96113	-8.560	9.054	-1.419	-4.722	-2.788	-0.276	1.225	-0.076
27 Slab EL27.0m @ RCCV	98472	-6.688	-5.372	14.755	-3.970	-2.975	-0.477	1.234	-1.689
	98514	12.327	-5.717	-3.144	-1.352	-0.396	-0.165	0.097	-0.409
	98424	-22.050	-2.417	-2.536	-1.455	-4.181	-0.018	-6.067	-0.162
28 Pool Girder @ Storage Pool	123054	-1.938	-2.515	1.566	5.417	5.584	0.162	-0.786	1.285
	123154	2.827	2.088	-1.845	4.580	2.974	-0.774	-0.233	0.669
29 Pool Girder @ Cavity	123062	-5.127	-4.093	-0.708	-0.074	0.431	0.003	-0.026	0.353
	123162	-3.908	-3.486	-2.637	-0.570	-0.433	0.167	-0.034	0.235
30 Pool Girder @ Fuel Pool	123067	-3.820	-9.165	-4.161	-2.718	-3.315	-0.123	-0.102	0.614
	123167	-2.808	-4.392	-4.025	-3.283	-3.669	-0.676	0.202	-0.166
31 MS Tunnel Wall and Slab	150122	1.806	2.306	-1.160	1.215	4.263	-0.061	-0.685	-0.069
	96611	-0.679	4.711	-0.495	-1.221	-6.974	-0.357	0.438	0.226
	98614	-0.780	9.698	-0.614	3.633	18.467	0.888	-1.338	-0.720
32 IC/PCCS Pool Wall in NS Direction	125051	-1.704	-1.534	-0.758	0.082	0.171	0.014	-0.047	0.053
	125151	-1.701	-1.207	1.885	0.196	0.283	0.076	-0.028	-0.077
	125055	-5.013	0.266	0.012	0.033	0.309	0.010	0.048	0.102
	125155	-5.698	-0.537	-0.141	-0.037	-0.038	-0.015	-0.287	0.230

Note: TWC1 is the same as Case1 described in Appendix E of reference 2.1.2-e where the temperatures in all pools are at their respective maximum values

SI to U.S. Customary units conversion (SI units are the controlling units and U.S. Customary units are for reference only): 1 MN/m = 6.852x10⁴ lbf/ft, 1 MNm/m = 2.248x10⁵ lbf-ft/ft



Table 6.2.4-8 Results of NASTRAN Analysis, Thermal Load (LOCA After 72 hours: Winter) – Load Case: TWC2 –

Table with 10 columns: Location, Element ID, Nx (MN/m), Ny (MN/m), Nxy (MN/m), Mx (MNm/m), My (MNm/m), Mxy (MNm/m), Qx (MN/m), Qy (MN/m). Rows include various structural components like walls, slabs, and girders.

Note: TWC2 is the same as Case2 described in Appendix E of reference 2.1.2-e where the temperatures in all pools are at their respective minimum values

SI to U.S. Customary units conversion (SI units are the controlling units and U.S. Customary units are for reference only): 1 MN/m = 6.852x10^4 lbf/ft, 1 MNm/m = 2.248x10^5 lbf-ft/ft

**Table 6.2.4-9 Results of NASTRAN Analysis, Thermal Load
(LOCA After 72 hours: Winter) – Load Case: TWC3 –**

Location	Element ID	Nx (MN/m)	Ny (MN/m)	Nxy (MN/m)	Mx (MNm/m)	My (MNm/m)	Mxy (MNm/m)	Qx (MN/m)	Qy (MN/m)
18 Wall Below RCCV Bottom	6	0.670	-1.048	-0.884	0.228	2.124	-0.056	0.036	0.354
	13	-0.306	-4.407	-0.752	0.662	3.674	-0.001	0.026	0.889
	24	-0.285	-4.247	0.242	0.695	3.877	-0.007	-0.003	0.983
19 Wall Below RCCV Mid-Height	806	1.890	-2.473	0.244	0.256	1.568	0.093	-0.079	-0.014
	813	1.335	-4.389	-0.414	0.228	1.677	-0.036	0.007	0.655
	824	0.950	-4.099	0.239	0.219	1.701	0.029	0.015	0.579
20 Wall Below RCCV Top	1606	15.501	-3.673	0.459	-0.798	-3.787	0.136	0.118	2.905
	1613	15.654	-5.156	-0.193	-1.006	-5.626	-0.012	-0.017	3.634
	1624	16.479	-4.986	-0.042	-1.133	-5.563	0.004	-0.109	3.708
21 Exterior Wall @ EL-11.50 ~10.50m	20011	3.738	5.777	1.168	0.527	2.192	0.048	-0.263	0.679
	20023	-3.155	-1.841	2.710	5.500	8.520	0.245	0.334	0.789
	30010	0.730	4.058	-0.335	1.354	5.126	-0.023	-0.036	-0.967
	30020	-0.041	-1.543	-0.341	-0.021	1.250	0.155	-0.024	-0.300
	40001	-0.093	-1.158	0.111	0.014	1.410	-0.103	0.127	-0.344
	40011	1.307	4.163	0.070	1.345	5.227	0.012	0.016	-1.006
22 Exterior Wall @ EL4.65 ~6.60m	22011	5.283	5.071	-0.144	-0.173	-0.135	0.076	0.039	0.187
	22023	4.084	-3.312	-4.149	-0.088	0.829	-0.019	1.179	0.777
	32010	16.572	7.841	-0.233	-2.885	-2.995	-0.009	-0.013	-0.003
	32020	0.592	5.227	2.415	0.068	-1.827	-0.358	1.193	0.181
	42001	2.758	4.202	2.357	0.077	-1.569	-0.027	-0.975	-0.229
	42011	14.894	6.046	0.372	-3.154	-2.920	0.066	0.093	0.074
23 Exterior Wall @ EL22.50 ~24.60m	24211	5.901	5.024	-0.316	-0.056	0.274	-0.060	-0.089	2.145
	24224	0.792	6.370	-3.057	1.898	-0.441	-0.919	-1.832	-0.756
	34210	21.464	5.958	-1.112	-2.937	-2.661	0.055	-0.015	-0.077
	34220	2.091	6.897	2.213	1.928	-1.515	-0.411	2.154	0.000
	44201	1.191	8.372	0.487	1.501	-1.692	0.512	-2.493	0.019
24 Basemat @ Wall Below RCCV	90140	1.635	1.927	1.899	-0.398	-1.472	-1.441	-1.162	0.167
	90182	2.138	0.785	0.554	-1.150	-6.045	0.298	-0.075	4.162
	90111	0.921	2.823	0.012	-6.151	-1.473	0.120	4.236	0.173
25 Slab EL4.65m @ RCCV	93140	-0.743	3.062	5.791	-0.806	-0.606	0.440	-0.202	0.176
	93182	6.126	-5.162	-1.596	-0.505	-2.611	-0.115	0.112	1.985
	93111	-4.387	6.774	-0.463	-2.578	-0.450	-0.072	1.745	0.002
26 Slab EL17.5m @ RCCV	96144	0.976	5.917	8.290	-0.370	-0.287	0.243	-0.049	0.114
	96186	10.139	-5.353	-2.466	-0.247	-1.241	-0.077	0.035	0.981
	96113	-8.614	7.958	-1.542	-4.967	-2.864	-0.274	1.328	-0.073
27 Slab EL27.0m @ RCCV	98472	-10.555	-5.730	14.877	-3.631	-2.841	-0.701	1.393	-1.882
	98514	19.208	-5.647	-2.587	1.045	2.953	-0.194	0.107	-1.118
	98424	-26.560	-3.101	-2.068	-0.369	-4.549	-0.180	-8.003	-0.294
28 Pool Girder @ Storage Pool	123054	-0.796	-10.849	0.720	6.148	6.064	0.167	0.364	0.243
	123154	2.563	-3.589	1.883	6.336	3.560	-0.289	0.575	0.983
29 Pool Girder @ Cavity	123062	-3.492	-7.610	-0.329	0.235	0.976	-0.143	0.144	0.349
	123162	-2.959	-6.337	-3.847	-0.450	0.157	0.052	0.056	0.215
30 Pool Girder @ Fuel Pool	123067	-1.268	-8.891	-3.861	-5.866	-6.788	0.001	-0.270	0.070
	123167	-0.187	-3.829	-3.108	-6.192	-5.622	-0.821	0.411	-0.590
31 MS Tunnel Wall and Slab	150122	1.442	2.727	-0.937	1.383	4.317	-0.079	-0.726	-0.235
	96611	-0.607	4.325	-0.440	-1.309	-7.168	-0.388	0.469	0.239
	98614	-1.663	14.438	-1.244	3.396	16.820	0.884	-1.208	-0.639
32 IC/PCCS Pool Wall in NS Direction	125051	-1.590	-0.135	-1.056	-0.896	-0.957	0.021	-0.132	0.072
	125151	-1.514	-0.093	1.642	-0.781	-0.803	0.065	-0.132	-0.123
	125055	-5.687	0.084	-0.180	-0.145	0.088	0.019	0.049	0.095
	125155	-6.471	-0.673	-0.245	-0.209	-0.233	-0.039	-0.277	0.218

Note: TWC3 is the same as Case3 described in Appendix E of reference 2.1.2-e where the temperatures in individual pools are at either maximum or minimum values

SI to U.S. Customary units conversion (SI units are the controlling units and U.S. Customary units are for reference only): 1 MN/m = 6.852x10⁴ lbf/ft, 1 MNm/m = 2.248x10⁵ lbf-ft/ft



**Table 6.2.4-10 Results of NASTRAN Analysis, Thermal Load
(LOCA After 72 hours: Winter) – Load Case: TWC4 –**

Location	Element ID	Nx (MN/m)	Ny (MN/m)	Nxy (MN/m)	Mx (MNm/m)	My (MNm/m)	Mxy (MNm/m)	Qx (MN/m)	Qy (MN/m)
18 Wall Below RCCV Bottom	6	0.675	-1.178	-1.016	0.262	2.320	-0.051	0.030	0.412
	13	-0.242	-4.702	-0.809	0.704	3.952	-0.005	0.028	0.972
	24	-0.604	-4.755	0.250	0.774	4.320	-0.008	-0.002	1.144
19 Wall Below RCCV Mid-Height	806	1.846	-2.644	0.093	0.261	1.580	0.104	-0.080	-0.008
	813	1.111	-4.721	-0.446	0.212	1.667	-0.030	0.012	0.690
	824	0.835	-4.606	0.243	0.222	1.671	0.028	0.016	0.650
20 Wall Below RCCV Top	1606	15.533	-3.964	0.374	-0.813	-3.869	0.153	0.120	2.938
	1613	15.095	-5.406	-0.355	-1.031	-5.552	-0.012	-0.016	3.584
	1624	16.752	-5.619	-0.068	-1.167	-5.895	-0.002	-0.104	3.825
21 Exterior Wall @ EL-11.50 ~10.50m	20011	3.795	5.903	1.189	0.577	2.392	0.051	-0.270	0.752
	20023	-3.161	-1.832	2.700	5.482	8.575	0.250	0.388	0.824
	30010	1.280	4.177	-0.135	1.383	5.346	-0.027	-0.038	-1.025
	30020	-0.047	-1.423	-0.094	-0.107	1.338	0.171	-0.059	-0.354
	40001	-0.189	-0.974	0.108	-0.041	1.567	-0.119	0.190	-0.408
	40011	1.324	4.622	0.125	1.434	5.725	0.012	0.019	-1.145
22 Exterior Wall @ EL4.65 ~6.60m	22011	5.179	4.982	-0.111	-0.165	-0.142	0.077	0.040	0.190
	22023	4.118	-2.984	-4.090	0.017	0.830	-0.042	1.153	0.774
	32010	16.202	7.169	-0.100	-2.889	-2.913	0.008	-0.015	-0.074
	32020	0.664	7.188	3.201	0.151	-1.847	-0.423	1.253	0.215
	42001	2.788	6.244	2.827	0.185	-1.584	-0.044	-1.022	-0.240
	42011	14.344	6.174	0.394	-3.161	-3.049	0.074	0.093	0.087
23 Exterior Wall @ EL22.50 ~24.60m	24211	4.557	6.000	-0.347	-0.071	0.612	0.027	-0.053	1.561
	24224	0.121	7.006	-4.004	0.358	-0.926	-0.198	-0.590	-0.758
	34210	15.370	6.254	-0.526	-2.754	-1.179	0.038	-0.021	0.478
	34220	0.813	6.354	1.257	0.023	-1.654	0.041	0.995	-0.089
	44201	0.441	7.044	0.691	-0.119	-1.881	0.038	-1.159	-0.037
24 Basemat @ Wall Below RCCV	90140	2.217	2.128	1.916	-0.818	-1.578	-1.423	-1.283	0.195
	90182	3.148	0.954	0.859	-1.590	-6.404	0.183	-0.090	4.451
	90111	1.131	2.903	0.021	-7.036	-1.884	0.104	4.764	0.201
25 Slab EL4.65m @ RCCV	93140	-0.910	3.162	5.824	-0.837	-0.625	0.452	-0.213	0.181
	93182	5.932	-5.098	-1.432	-0.529	-2.714	-0.128	0.114	2.071
	93111	-4.509	6.889	-0.465	-2.694	-0.475	-0.074	1.828	0.003
26 Slab EL17.5m @ RCCV	96144	0.330	5.674	8.334	-0.320	-0.220	0.183	-0.022	0.097
	96186	8.414	-6.391	-2.245	-0.169	-0.866	-0.064	0.009	0.591
	96113	-9.043	4.914	-1.906	-4.765	-2.896	-0.247	1.068	-0.101
27 Slab EL27.0m @ RCCV	98472	-0.712	2.508	15.854	2.844	3.563	-1.727	1.485	-1.701
	98514	8.714	-4.774	-2.722	1.284	5.685	0.103	-0.091	-2.673
	98424	-15.856	5.965	-3.125	15.820	11.004	0.128	-6.566	-0.270
28 Pool Girder @ Storage Pool	123054	9.857	-7.176	3.794	0.061	-0.484	-0.222	0.790	-0.570
	123154	7.646	-1.589	2.072	0.291	0.127	-0.235	0.262	0.022
29 Pool Girder @ Cavity	123062	11.194	0.038	-2.026	-0.395	0.719	0.207	1.138	-0.117
	123162	7.371	0.069	-1.416	-0.059	0.546	-0.247	0.304	-0.082
30 Pool Girder @ Fuel Pool	123067	7.387	-5.704	-5.204	0.309	-0.082	-0.083	-0.415	-0.377
	123167	4.800	-1.367	-2.400	0.306	0.335	0.026	-0.128	0.066
31 MS Tunnel Wall and Slab	150122	0.742	4.103	-0.960	1.295	3.836	0.103	-0.663	-0.248
	96611	-0.506	3.602	-0.370	-1.578	-7.780	-0.504	0.546	0.261
	98614	-0.406	3.864	-0.323	2.971	17.180	0.787	-1.065	-0.522
32 IC/PCCS Pool Wall in NS Direction	125051	3.473	-2.171	0.893	-0.574	-0.630	0.049	-0.282	-0.058
	125151	1.753	-1.442	-0.967	-0.439	-0.226	-0.016	-0.265	-0.069
	125055	6.938	0.773	-0.207	0.007	-0.199	-0.001	0.298	0.181
	125155	3.393	0.481	0.012	0.006	-0.149	-0.010	0.012	-0.083

Note: TWC4 is the same as Case4 described in Appendix E of reference 2.1.2-e where the temperatures in all pools are at 0°C

SI to U.S. Customary units conversion (SI units are the controlling units and U.S. Customary units are for reference only): 1 MN/m = 6.852x10⁴ lbf/ft, 1 MNm/m = 2.248x10³ lbf-ft/ft

**Table 6.2.4-11 Results of NASTRAN Analysis, Site-Specific Seismic Load
(Horizontal: North to South Direction)**

Location	Element ID	Nx (MN/m)	Ny (MN/m)	Nxy (MN/m)	Mx (MNm/m)	My (MNm/m)	Mxy (MNm/m)	Qx (MN/m)	Qy (MN/m)
18 Wall Below RCCV Bottom	6	-0.783	-1.624	-0.038	0.162	1.122	0.025	-0.037	0.414
	13	0.522	1.176	-0.115	0.157	0.785	-0.009	0.013	0.205
	24	0.758	3.600	0.062	0.072	0.397	0.000	0.000	0.021
19 Wall Below RCCV Mid-Height	806	-1.220	-2.023	-0.301	-0.030	0.015	0.051	0.010	-0.010
	813	0.027	1.363	-0.375	-0.005	-0.018	0.029	0.005	0.063
	824	0.969	3.912	0.024	-0.007	-0.032	0.000	0.002	0.062
20 Wall Below RCCV Top	1606	-1.574	-2.018	-1.434	-0.048	-0.075	-0.033	0.025	-0.069
	1613	-0.179	1.334	-1.602	-0.080	-0.300	-0.016	0.010	0.059
	1624	1.266	3.651	-0.082	-0.034	-0.254	-0.003	-0.002	0.089
21 Exterior Wall @ EL-11.50 ~10.50m	20011	0.092	-0.658	0.266	0.593	2.400	0.008	-0.008	0.889
	20023	-0.024	-0.479	-0.045	-0.317	0.400	0.065	0.427	0.293
	30010	1.085	0.430	-0.564	0.100	0.568	-0.002	-0.008	-0.153
	30020	-0.001	0.896	0.105	-0.014	0.299	0.011	-0.100	-0.091
	40001	0.008	0.890	-0.267	-0.048	0.225	-0.020	0.056	-0.080
	40011	0.684	0.478	0.028	-0.005	0.031	0.001	-0.002	0.036
22 Exterior Wall @ EL4.65 ~6.60m	22011	-0.409	-4.278	1.316	0.110	0.748	0.071	-0.043	0.598
	22023	-0.129	-3.435	0.177	-0.124	0.208	-0.115	0.282	0.131
	32010	-0.477	0.875	-2.847	-0.010	-0.020	-0.002	-0.004	-0.012
	32020	0.107	4.483	-1.209	0.109	0.014	-0.005	0.092	0.008
	42001	0.154	4.717	-0.785	0.135	-0.066	-0.001	-0.073	0.027
	42011	1.001	2.927	0.147	-0.032	-0.207	0.008	0.000	0.181
23 Exterior Wall @ EL22.50 ~24.60m	24211	-0.878	-4.111	0.148	-0.125	-0.314	-0.029	-0.002	0.740
	24224	-0.319	-7.118	0.933	0.671	1.055	-0.249	0.228	1.171
	34210	-0.945	0.276	-3.286	-0.016	-0.078	0.000	0.023	-0.028
	34220	-0.087	2.292	-0.946	-0.075	0.037	0.018	-0.060	-0.016
	44201	-0.140	2.787	-0.468	-0.044	0.034	-0.013	0.086	-0.006
24 Basemat @ Wall Below RCCV	90140	2.760	0.669	-0.723	-2.536	-1.105	0.361	-0.675	0.793
	90182	1.990	0.248	-0.604	-0.522	0.386	0.127	0.010	-0.090
	90111	0.282	1.008	-0.031	1.675	0.096	0.154	-1.230	-0.110
25 Slab EL4.65m @ RCCV	93140	-1.696	0.303	-0.213	-0.204	-0.125	0.095	-0.046	0.062
	93182	-0.251	-0.090	0.093	-0.006	-0.003	0.010	0.005	0.012
	93111	-0.141	0.204	-0.030	0.349	0.060	0.012	-0.248	0.001
26 Slab EL17.5m @ RCCV	96144	-0.554	0.255	0.093	-0.173	-0.143	0.099	-0.037	0.042
	96186	-0.427	-0.127	0.132	-0.003	-0.012	0.010	0.010	0.008
	96113	0.046	-0.904	-0.097	1.094	0.112	0.012	-0.905	-0.108
27 Slab EL27.0m @ RCCV	98472	0.655	-0.206	-0.040	-0.206	-0.213	0.071	-0.021	0.039
	98514	-0.509	-0.071	0.098	-0.027	0.040	0.057	0.035	-0.006
	98424	0.940	-1.110	0.070	-0.825	-0.252	0.087	0.954	0.076
28 Pool Girder @ Storage Pool	123054	0.078	1.309	-0.293	-0.042	-0.015	0.028	0.013	0.002
	123154	-0.864	0.481	-0.105	-0.056	-0.017	0.005	-0.009	0.001
29 Pool Girder @ Cavity	123062	-0.152	-0.096	0.234	-0.001	0.004	-0.008	0.001	0.005
	123162	-0.462	-0.123	0.274	-0.007	0.003	-0.007	-0.010	-0.001
30 Pool Girder @ Fuel Pool	123067	-0.535	0.362	0.423	0.065	0.049	0.012	0.020	0.033
	123167	-0.479	-0.107	0.751	0.025	0.023	0.001	0.004	0.005
31 MS Tunnel Wall and Slab	150122	-0.029	0.276	-0.061	-0.060	-0.205	-0.009	0.011	-0.032
	96611	-0.002	-0.057	0.005	-0.169	-0.550	-0.047	0.067	0.024
	98614	0.048	-0.362	0.037	0.174	0.743	0.063	-0.058	-0.025
32 IC/PCCS Pool Wall in NS Direction	125051	0.017	0.133	0.376	0.004	0.004	0.000	0.004	-0.010
	125151	-0.110	0.133	0.414	0.009	0.006	0.000	0.006	-0.003
	125055	-0.115	-0.023	0.460	-0.005	-0.006	0.003	-0.003	-0.003
	125155	-0.221	-0.004	0.470	0.000	0.005	0.003	0.005	-0.004

SI to U.S. Customary units conversion (SI units are the controlling units and U.S. Customary units are for reference only): 1 MN/m = 6.852x10⁴ lbf/ft, 1 MNm/m = 2.248x10⁵ lbf-ft/ft

**Table 6.2.4-12 Results of NASTRAN Analysis, Site-Specific Seismic Load
(Horizontal: East to West Direction)**

Location	Element ID	Nx (MN/m)	Ny (MN/m)	Nxy (MN/m)	Mx (MNm/m)	My (MNm/m)	Mxy (MNm/m)	Qx (MN/m)	Qy (MN/m)
18 Wall Below RCCV Bottom	6	-1.362	-3.188	0.325	0.163	0.904	0.007	-0.033	0.385
	13	-1.290	-3.599	-0.300	0.128	0.707	0.012	-0.016	0.334
	24	-0.156	-0.336	-1.107	-0.013	-0.020	-0.009	0.014	0.008
19 Wall Below RCCV Mid-Height	806	-0.523	-3.092	0.837	0.029	0.036	0.035	0.007	-0.032
	813	-1.029	-3.722	-0.421	0.023	0.025	0.019	0.000	0.063
	824	-0.085	-0.368	-1.651	-0.003	-0.002	-0.008	-0.004	-0.011
20 Wall Below RCCV Top	1606	-0.366	-2.610	1.656	-0.001	-0.153	0.019	0.006	0.059
	1613	-0.805	-3.269	-0.482	-0.059	-0.366	0.017	-0.003	0.113
	1624	-0.112	-0.330	-2.605	0.003	0.020	-0.038	0.016	-0.004
21 Exterior Wall @ EL-11.50 ~10.50m	20011	0.104	0.367	1.984	0.001	-0.207	-0.018	-0.021	-0.055
	20023	-0.016	-1.243	0.171	-0.115	0.079	0.040	0.153	0.095
	30010	-0.635	-0.216	-0.743	0.163	0.762	0.015	0.012	-0.232
	30020	-0.102	-0.927	-0.550	0.040	-0.084	-0.006	-0.008	0.045
	40001	0.061	-1.082	-0.238	-0.107	-0.318	-0.001	-0.133	0.070
22 Exterior Wall @ EL4.65 ~6.60m	40011	0.009	-0.030	-1.125	-0.020	-0.069	-0.006	-0.016	0.027
	22011	-0.104	-1.029	3.564	-0.014	-0.010	-0.004	-0.011	-0.017
	22023	-0.323	-3.988	2.727	0.085	0.080	-0.032	0.027	0.047
	32010	-0.595	-2.880	-0.678	0.023	0.132	0.013	0.000	-0.202
	32020	-0.093	-3.812	-1.603	-0.041	0.074	0.007	-0.048	-0.040
23 Exterior Wall @ EL22.50 ~24.60m	42001	-0.085	-3.676	-2.018	-0.062	-0.030	0.010	0.029	0.012
	42011	-0.066	0.437	-3.545	-0.002	-0.007	-0.012	-0.004	0.000
	24211	-0.012	0.063	3.573	0.006	0.015	-0.008	0.000	0.002
	24224	-0.371	-5.221	3.445	0.319	0.211	-0.015	-0.223	0.158
	34210	-0.182	-1.740	-0.569	-0.107	-0.609	0.007	0.004	-0.191
24 Basemat @ Wall Below RCCV	44201	-0.059	-2.191	-2.196	-0.016	-0.007	-0.033	0.026	-0.017
	90140	0.090	-0.409	-1.411	-1.245	-1.547	1.181	-1.254	1.198
	90182	-0.890	-0.003	-0.539	-0.538	-1.570	0.223	-0.026	1.660
25 Slab EL4.65m @ RCCV	90111	0.044	-0.185	0.345	0.059	-0.084	-0.381	0.065	0.451
	93140	-0.082	-0.051	0.108	-0.132	-0.116	0.077	-0.040	0.028
	93182	-0.099	0.065	0.096	-0.093	-0.469	-0.016	0.020	0.392
26 Slab EL17.5m @ RCCV	93111	0.094	0.021	-0.148	-0.007	0.004	0.000	-0.001	-0.003
	96144	0.080	0.194	0.113	-0.112	-0.112	0.074	-0.039	0.016
	96186	0.192	-0.068	0.160	-0.105	-0.544	-0.020	0.026	0.445
27 Slab EL27.0m @ RCCV	96113	-0.018	0.110	-0.595	-0.069	-0.017	-0.045	0.043	-0.033
	98472	0.062	0.772	0.239	-0.053	-0.060	0.025	0.055	-0.076
	98514	0.363	-0.183	0.348	-0.167	-1.101	0.002	0.020	0.701
28 Pool Girder @ Storage Pool	98424	-0.202	0.194	3.448	-0.001	-0.023	0.123	-0.042	-0.040
	123054	-0.250	-0.289	-0.162	-0.197	-0.091	0.054	-0.023	-0.061
29 Pool Girder @ Cavity	123154	0.240	-0.389	-0.563	-0.156	-0.010	0.067	-0.017	-0.004
	123062	0.197	-0.814	-0.044	-0.038	-0.026	0.009	0.028	-0.001
30 Pool Girder @ Fuel Pool	123162	0.256	-0.817	-0.052	-0.027	0.002	-0.008	0.028	-0.021
	123067	-0.049	-0.123	-0.097	-0.090	-0.092	-0.051	-0.014	-0.075
31 MS Tunnel Wall and Slab	123167	0.276	-0.388	0.341	-0.065	0.017	-0.041	0.013	-0.008
	150122	0.005	-0.093	0.022	0.024	0.074	0.029	-0.005	-0.158
	96611	-0.017	0.048	0.029	0.012	0.055	-0.047	0.000	0.054
32 IC/PCCS Pool Wall in NS Direction	98614	-0.008	-0.006	0.003	-0.023	-0.092	-0.262	0.023	0.011
	125051	0.083	-0.069	0.125	0.009	0.008	0.004	0.003	-0.002
	125151	0.042	-0.061	0.009	0.008	0.000	0.005	0.004	0.004
	125055	0.221	-0.010	-0.058	-0.001	0.007	0.001	0.000	-0.001
	125155	0.194	-0.013	-0.059	-0.002	0.000	-0.001	-0.004	0.007

SI to U.S. Customary units conversion (SI units are the controlling units and U.S. Customary units are for reference only): 1 MN/m = 6.852x10⁴ lbf/ft, 1 MNm/m = 2.248x10⁵ lbf-ft/ft



**Table 6.2.4-13 Results of NASTRAN Analysis, Site-Specific Seismic Load
(Vertical: Upward Direction)**

Location	Element ID	Nx (MN/m)	Ny (MN/m)	Nxy (MN/m)	Mx (MNm/m)	My (MNm/m)	Mxy (MNm/m)	Qx (MN/m)	Qy (MN/m)
18 Wall Below RCCV Bottom	6	0.390	-6.640	0.527	-0.361	-2.351	0.013	-0.038	-0.756
	13	0.501	-5.422	0.409	-0.612	-3.320	0.005	-0.006	-1.021
	24	0.458	-6.058	-0.161	-0.651	-3.531	0.006	-0.002	-1.060
19 Wall Below RCCV Mid-Height	806	-0.001	-5.924	0.178	0.011	-0.049	-0.022	0.007	-0.115
	813	-0.174	-5.442	0.360	-0.026	-0.047	-0.010	-0.019	-0.214
	824	-0.129	-6.106	-0.147	-0.033	-0.002	-0.007	0.001	-0.232
20 Wall Below RCCV Top	1606	-0.709	-5.409	0.135	0.187	1.012	0.008	-0.003	-0.344
	1613	-0.841	-5.281	0.271	0.181	1.101	0.007	0.000	-0.395
	1624	-0.755	-5.937	-0.093	0.184	1.094	0.000	-0.006	-0.384
21 Exterior Wall @ EL-11.50 ~10.50m	20011	-0.571	-3.328	-0.340	-0.035	0.005	0.004	0.048	0.042
	20023	0.005	-1.108	-0.390	0.106	-0.219	-0.007	-0.084	-0.134
	30010	-0.160	-1.781	0.051	-0.371	-1.965	0.016	0.003	0.460
	30020	-0.053	-0.988	-0.201	0.187	-0.567	-0.058	0.127	0.191
	40001	-0.049	-1.028	0.164	0.191	-0.576	0.058	-0.127	0.186
	40011	-0.323	-2.306	0.001	-0.423	-2.233	-0.011	-0.001	0.530
22 Exterior Wall @ EL4.65 ~6.60m	22011	0.185	-3.014	0.654	-0.007	0.056	0.001	-0.021	0.061
	22023	0.005	-1.557	-0.255	-0.117	0.001	-0.014	0.078	0.015
	32010	-0.033	-1.772	0.059	0.000	0.039	0.003	0.000	-0.025
	32020	-0.049	-1.973	-0.093	-0.063	-0.004	-0.006	-0.056	-0.009
	42001	-0.058	-2.061	-0.089	-0.081	-0.005	0.003	0.041	-0.002
	42011	-0.319	-2.366	-0.078	-0.002	0.037	-0.004	0.003	-0.020
23 Exterior Wall @ EL22.50 ~24.60m	24211	-0.245	-1.884	0.122	-0.082	-0.546	0.006	-0.002	-0.047
	24224	-0.060	-1.302	0.460	0.055	-0.028	-0.055	-0.067	-0.007
	34210	-0.054	-0.868	0.063	-0.009	-0.116	0.001	0.006	-0.015
	34220	0.040	-0.964	-0.213	0.053	-0.040	0.001	0.044	0.001
	44201	0.026	-1.163	-0.393	0.046	-0.021	0.010	-0.047	-0.002
24 Basemat @ Wall Below RCCV	90140	0.292	-0.734	-0.477	-2.136	-1.628	3.174	-1.481	1.751
	90182	-0.623	-0.317	-0.066	0.837	-2.260	-0.383	0.221	0.666
	90111	-0.387	-0.896	0.058	-2.068	1.015	-0.489	0.713	0.115
25 Slab EL4.65m @ RCCV	93140	-0.089	0.124	0.064	0.052	0.072	-0.045	0.102	-0.083
	93182	0.115	0.099	0.018	0.025	0.072	0.006	-0.007	-0.132
	93111	0.070	0.144	-0.026	0.101	0.028	0.004	-0.130	-0.003
26 Slab EL17.5m @ RCCV	96144	-0.171	0.227	0.164	0.028	0.034	-0.026	0.094	-0.070
	96186	0.258	-0.093	-0.035	-0.007	-0.053	0.003	-0.004	-0.007
	96113	-0.076	0.554	-0.083	-0.296	0.011	0.011	0.337	0.034
27 Slab EL27.0m @ RCCV	98472	0.381	-0.046	0.256	0.418	0.684	-0.574	0.444	-0.521
	98514	0.135	0.039	0.068	0.061	0.301	0.046	-0.023	-0.205
	98424	-0.230	0.416	-0.030	2.488	0.577	0.020	-1.510	-0.116
28 Pool Girder @ Storage Pool	123054	0.490	-3.033	-1.047	0.034	0.033	0.088	0.014	0.035
	123154	1.605	-0.550	-0.833	0.044	-0.004	0.122	0.057	-0.009
29 Pool Girder @ Cavity	123062	0.502	0.763	0.407	-0.053	-0.286	0.025	0.018	-0.128
	123162	-1.839	0.280	0.213	-0.096	-0.088	0.019	0.106	0.032
30 Pool Girder @ Fuel Pool	123067	0.459	-2.959	1.895	0.005	-0.068	-0.104	-0.129	-0.023
	123167	0.647	-0.692	1.644	0.019	-0.002	0.013	-0.045	-0.010
31 MS Tunnel Wall and Slab	150122	-0.029	0.142	0.341	0.021	0.007	0.026	-0.015	-0.074
	96611	-0.017	0.396	-0.019	0.065	-0.289	-0.103	-0.109	0.035
	98614	-0.024	-0.249	-0.021	0.016	-0.565	-0.065	-0.057	0.036
32 IC/PCCS Pool Wall in NS Direction	125051	-0.140	-1.646	-1.201	0.006	-0.074	-0.003	0.006	-0.055
	125151	-0.160	-0.650	-0.995	0.001	-0.011	-0.006	0.015	-0.003
	125055	0.057	-0.200	-0.105	-0.024	-0.137	0.004	-0.045	-0.088
	125155	-0.704	-0.139	-0.088	0.006	0.034	0.007	0.046	-0.051

SI to U.S. Customary units conversion (SI units are the controlling units and U.S. Customary units are for reference only): 1 MN/m = 6.852x10⁴ lbf/ft, 1 MNm/m = 2.248x10⁵ lbf-ft/ft



Table 6.3.1-1 Load Combinations and Acceptance Criteria for Safety-Related Reinforced Concrete Structures

Category	Combination ^{*2} No.	Load ^{*1}											Acceptance Criteria ^{*5}		
		D	F	L	H	Pa ^{*3}	To	Ta ^{*3}	E'	W	Wt	Ro		Ra	Y ^{*4}
Normal	RB-C1	1.4	1.4	1.7	1.7							1.7			U
	RB-C2	1.05	1.05	1.3	1.3		1.3					1.3			U
Severe Environmental	RB-C3	1.4	1.4	1.7	1.7					1.7		1.7			U
	RB-C4	1.05	1.05	1.3	1.3		1.3			1.3		1.3			U
	RB-C5	1.2	1.2							1.7					U
Extreme Environmental	RB-C6	1.0	1.0	1.0	1.0		1.0		1.0			1.0			U
	RB-C7	1.0	1.0	1.0	1.0		1.0				1.0	1.0			U
Abnormal	RB-C8	1.0	1.0	1.0	1.0	1.5		1.0					1.0		U
Abnormal/Extreme Environmental	RB-C9	1.0	1.0	1.0	1.0	1.0		1.0	1.0				1.0	1.0	U

Note :

- *1: D = Dead loads
 L = Live loads (For the roof, Roof Live loads or Snow loads or Rain loads each acting independently.)
 H = Lateral soil pressure loads
 To = Thermal loads during the normal operation
 E' = Seismic loads (SSE)
 W = Wind loads (basic wind)
 Ro = Pipe reaction loads during the normal operation
 Y = High energy pipe rupture
- F = Hydrostatic pressure loads
 Pa = Pressure loads during LOCA
 Ta = Thermal loads during LOCA
 Wt = Wind loads (tornado wind)
 Ra = Pipe reaction loads during LOCA
- *2: For any load combination, where any load reduces the effects of other loads, the corresponding coefficient for that load shall be taken as 0.9 if it can be demonstrated that the load is always present or occur simultaneously with the other loads. Otherwise, the coefficient for that load shall be taken as zero.
- *3: Because Pa and Ta are time-dependent loads, their effects are superimposed accordingly.
- *4: Y includes Yj, Ym and Yr. The maximum value of Y including an appropriate Dynamic Load Factor (DLF) shall be used, unless an appropriate time history analysis is performed to justify otherwise.
- *5: U = Section strength required to resist design loads based on the strength design method per ACI 349-01 and in SRP 3.8.4 Section II.3.



Table 6.3.1-2 Load Combinations, Load Factors and Acceptance Criteria for Reinforced Concrete Containment

Description	No. ^{*2}	Load Conditions ^{*1}															Acceptance Criteria ^{*6}	
		D	L	Pt	Po	Pa ^{*3}	Tt	To	Ta ^{*3}	E ^{*7}	W	W'	Ro	Ra	Y ^{*4}	SRV ^{*7}		LOCA ^{*5*7}
Service																		
Test	CV-1	1.0	1.0	1.0			1.0											S
Construction	CV-2	1.0	1.0					1.0			1.0							S
Normal	CV-3	1.0	1.0		1.0			1.0				1.0				1.0		S
Factored																		
Severe Environmental	CV-4	1.0	1.3		1.0			1.0			1.5		1.0			1.3		U
Extreme Environmental	CV-5	1.0	1.0		1.0			1.0	1.0				1.0			1.0		U
	CV-6	1.0	1.0		1.0			1.0			1.0	1.0				1.0		U
Abnormal	CV-7	1.0	1.0			1.5			1.0					1.0		1.25	Note ^{*5}	U
	CV-8	1.0	1.0			1.0			1.0					1.25		1.0	Note ^{*5}	U
	CV-9	1.0	1.0			1.25			1.0					1.0		1.25	Note ^{*5}	U
Abnormal/Severe Environmental	CV-10	1.0	1.0			1.25			1.0		1.25			1.0		1.0	Note ^{*5}	U
Abnormal/Extreme Environmental	CV-11	1.0	1.0			1.0			1.0	1.0				1.0	1.0	1.0	Note ^{*5}	U

Notes:

- *1: The loads are described in Section 6. The allowable stresses of concrete and reinforcing steel shall be in accordance with ASME Code Section III, Division 2, Subsection CC-3400 (except for tangential shear stress carried by orthogonal reinforcement which shall be limited to 4.41 MPa (639 psi) for factored load combinations). Inclined reinforcement shall not be used to resist tangential shear.
- *2: For any load combination, if the effect of any load component (other than D) reduces the combined load, then the load component is deleted from the load combination.
- *3: Because Pa, Ta, SRV and LOCA are time-dependent loads, their effects are superimposed accordingly.
- *4: Y includes Yj, Ym and Yr.
- *5: LOCA loads, CO, CHUG and PS are time-dependant loads for which DLF may be used. The sequence of occurrence is shown in Figure 5.2.3-2. The load factor for LOCA loads shall be the same as the corresponding pressure load Pa. LOCA loads shall include hydrostatic pressure (with a load factor of 1.0) due to containment flooding.
- *6: S = Allowable Stress as in ASME Section III, Div. 2, Subsection CC-3430 for Service Load Combination. U = Allowable Stress as in ASME Section III, Div. 2, Subsection CC-3420 for Factored Load Combination.
- *7: The peak responses of dynamic loads do not occur at the same instant. SRSS method to combine peak dynamic responses is acceptable for concrete structures.



Table 6.3.1-3 Load Combinations and Acceptance Criteria for Safety-Related Steel Structures

Category	Combination No.	Load											Acceptance Criteria ^{*2}
		D	L	Pa	To	Ta	E'	W	Wt	Ro	Ra	Y ¹	
Normal	RB-S1	1.0	1.0										S
	RB-S2	1.0	1.0		1.0					1.0			S (a)
Severe Environmental	RB-S3	1.0	1.0					1.0					S
	RB-S4	1.0	1.0		1.0			1.0		1.0			S (a)
Extreme Environmental	RB-S5	1.0	1.0		1.0		1.0			1.0			1.6S (b) (c)
	RB-S6	1.0	1.0		1.0				1.0	1.0			1.6S (b) (c)
Abnormal	RB-S7	1.0	1.0	1.0		1.0					1.0		1.6S (b) (c)
Abnormal/Extreme Environmental	RB-S8	1.0	1.0	1.0		1.0	1.0				1.0	1.0	1.7S (b) (c)

Note :
 D = Dead loads
 L = Live loads (For the roof, Roof Live loads or Snow loads or Rain loads each acting independently.)
 Pa = Pressure loads during LOCA
 To = Thermal loads during the normal operation Ta = Thermal loads during LOCA
 E' = Seismic loads (SSE)
 W = Wind loads (basic wind) Wt = Wind loads (tornado wind)
 Ro = Pipe reaction loads during the normal operation Ra = Pipe reaction loads during LOCA
 Y = High energy pipe rupture

- *1: Y includes Y_j, Y_m and Y_r. The maximum values of Y including an appropriate Dynamic Load Factor (DLF) shall be used, unless an appropriate time history analysis is performed to justify otherwise.
- *2: Allowable elastic working stress (S) is the allowable stress limit specified in Part 1 of ANSI/AISC N-690-1994-s2 (2004).
 - (a) For primary plus secondary stress, the allowable limits are increased by a factor of 1.5.
 - (b) Stress limit coefficient in shear shall not exceed 1.4 in members and bolts.
 - (c) Stress limit coefficient where axial compression exceeds 20% of nominal allowable, shall be 1.5 for load combination 5, 6, 7, and be 1.6 for load combination 8.

Table 6.3.2-1 Detail Load Combinations for RB Design (Continued)

Large data table with multiple columns including load types (Dead, Live, Pressure, Thermal, Seismic, Pipe, Hydrodynamic, Wind, Tornado), load IDs, and acceptance criteria (U, U').

Note *1: GDCS Pool Water Depth is 4.48 m.
*2: GDCS Pool Water Depth is 0.792 mm.
Opposite sign of stresses due to the hydrodynamic load or combination of hydrodynamic and seismic load to the other loads is considered. In that case, 500 is added to the original LOAD ID.
For acceptance criteria, U = Allowable Stress as in ASME Section III, Div. 2, Subsection CC-3420 for Factored Load Combination.
For unit load cases which are shaded in the table, the results of stress analysis are based on the RB/FB global FE model which is used in Appendix E of ESBWR Reactor Building Structural Design Report, Reference 2.1.2-e.



Table 6.3.3-1 Combined Forces and Moments: 1.05D + 1.3L + 1.3To + 1.3W: Winter: Load ID = 4021 (Selected Load Combination RB-4)

Location	Element ID		Nx (MN/m)	Ny (MN/m)	Nxy (MN/m)	Mx (MNm/m)	My (MNm/m)	Mxy (MNm/m)	Qx (MN/m)	Qy (MN/m)
18 Wall Below RCCV Bottom	6	OTHR	-1.555	-7.620	-0.224	-0.205	-1.498	-0.004	-0.001	-0.347
		TEMP	1.628	-0.267	-0.739	0.099	1.178	-0.043	0.016	0.044
	13	OTHR	-1.519	-5.859	-0.062	-0.552	-2.918	0.007	-0.004	-0.807
		TEMP	0.500	-3.267	-0.851	0.466	2.640	-0.003	0.023	0.576
	24	OTHR	-1.096	-6.372	-0.195	-0.617	-3.726	0.000	0.001	-1.250
		TEMP	0.791	-3.390	0.142	0.480	2.679	-0.006	-0.001	0.596
19 Wall Below RCCV Mid-Height	806	OTHR	-1.572	-6.384	-0.155	-0.008	-0.036	-0.031	-0.016	-0.096
		TEMP	1.438	-1.233	0.113	0.162	1.001	0.089	-0.059	0.052
	813	OTHR	-2.080	-5.697	0.108	-0.040	0.060	-0.009	-0.005	-0.081
		TEMP	0.801	-3.203	-0.655	0.112	1.009	-0.029	0.009	0.603
	824	OTHR	-2.360	-6.305	-0.077	0.117	0.440	0.012	-0.001	0.098
		TEMP	0.618	-3.509	0.100	0.129	1.019	0.019	0.011	0.540
20 Wall Below RCCV Top	1606	OTHR	-1.035	-5.717	0.046	0.046	0.276	0.030	0.007	-0.193
		TEMP	9.010	-2.016	0.181	-0.500	-2.273	0.101	0.089	1.713
	1613	OTHR	-1.243	-5.474	0.243	0.019	0.266	-0.001	-0.002	-0.194
		TEMP	8.724	-3.628	-0.531	-0.636	-3.693	-0.004	-0.014	2.219
	1624	OTHR	-0.831	-5.849	-0.015	-0.014	-0.180	0.005	-0.008	-0.001
		TEMP	9.355	-4.562	-0.137	-0.712	-3.632	-0.005	-0.066	2.268
21 Exterior Wall @ EL-11.50 ~10.50m	20011	OTHR	-2.257	-3.859	-0.805	0.097	0.687	0.010	0.046	0.224
		TEMP	3.715	3.601	0.919	0.284	1.218	0.038	-0.186	0.357
	20023	OTHR	-1.511	-1.525	-0.594	-0.014	-0.246	0.020	-0.030	-0.138
		TEMP	-1.892	-1.622	2.144	2.538	5.046	0.244	0.376	0.822
	30010	OTHR	-1.682	-2.499	-0.260	-0.334	-1.774	0.015	0.002	1.170
		TEMP	0.175	2.955	-0.157	1.319	4.158	-0.022	-0.030	-0.727
	30020	OTHR	-1.290	-1.608	-0.209	-0.698	-0.860	0.024	-0.254	0.370
		TEMP	-0.154	-1.324	-0.285	0.170	1.409	0.142	-0.039	-0.357
	40001	OTHR	-1.000	-1.845	0.312	-0.424	-1.299	-0.264	0.132	0.770
		TEMP	-0.205	-0.878	-0.095	0.220	1.540	-0.094	0.145	-0.398
	40011	OTHR	-1.645	-3.401	-0.032	-0.398	-2.279	-0.004	0.007	2.059
		TEMP	1.019	3.116	0.054	1.305	4.252	0.008	0.014	-0.766
22 Exterior Wall @ EL4.65 ~6.60m	22011	OTHR	-0.236	-3.251	0.764	-0.005	0.072	0.012	-0.024	0.116
		TEMP	2.586	3.076	-0.119	-0.101	-0.086	0.038	0.020	0.147
	22023	OTHR	-0.106	-1.773	0.013	0.005	0.018	-0.065	0.073	0.020
		TEMP	2.357	-5.300	-2.630	-0.374	0.466	-0.053	0.922	0.549
	32010	OTHR	-0.379	-2.094	-0.001	-0.025	-0.083	0.000	0.001	-0.011
		TEMP	16.055	7.706	0.016	-3.506	-3.286	-0.003	-0.003	-0.226
	32020	OTHR	-0.049	-1.922	0.010	-0.099	-0.076	-0.017	-0.040	0.019
		TEMP	0.404	5.236	2.974	-0.744	-2.379	-0.509	0.936	0.144
	42001	OTHR	-0.038	-2.008	-0.024	-0.086	-0.111	0.058	0.033	0.054
		TEMP	2.925	3.711	3.106	-0.956	-2.146	-0.063	-0.860	-0.349
	42011	OTHR	-0.559	-2.726	-0.052	-0.035	-0.165	0.003	0.006	0.021
		TEMP	13.976	5.189	0.082	-3.633	-3.196	0.101	0.088	-0.115
23 Exterior Wall @ EL22.50 ~24.60m	24211	OTHR	-0.194	-1.961	0.107	-0.076	-0.511	0.006	-0.002	-0.059
		TEMP	3.696	2.547	-0.486	-0.016	0.049	0.013	-0.150	2.136
	24224	OTHR	-0.027	-1.174	0.344	0.059	-0.042	-0.043	-0.084	-0.025
		TEMP	0.155	4.828	-4.303	0.833	-0.313	-0.715	-0.808	-0.293
	34210	OTHR	-0.021	-0.895	0.012	-0.008	-0.094	0.000	0.005	-0.008
		TEMP	17.402	5.781	-0.557	-3.633	-3.490	0.035	-0.012	-0.199
	34220	OTHR	0.032	-0.921	-0.179	0.038	-0.038	-0.002	0.044	0.003
		TEMP	2.056	4.894	2.979	0.866	-2.104	-0.558	1.943	0.152
	44201	OTHR	0.032	-1.089	-0.329	0.043	-0.016	0.013	-0.037	-0.002
		TEMP	1.125	5.799	-0.132	0.393	-2.344	0.550	-2.362	0.138

OTHR: Loads other than thermal loads

TEMP: Thermal loads

SI to U.S. Customary units conversion (SI units are the controlling units and U.S. Customary units are for reference only):

1 MN/m = 6.852x10⁴ lbf/ft

1 MNm/m = 2.248x10⁵ lbf-ft/



Table 6.3.3-1 Combined Forces and Moments: 1.05D + 1.3L + 1.3To + 1.3W: Winter: Load ID = 4021 (Selected Load Combination RB-4) (Continued)

Location	ElementID		Nx (MN/m)	Ny (MN/m)	Nxy (MN/m)	Mx (MNm/m)	My (MNm/m)	Mxy (MNm/m)	Qx (MN/m)	Qy (MN/m)
24 Basemat @ Wall Below RCCV	90140	OTHR	-4.095	-3.414	-0.095	-2.222	-1.166	2.690	-2.138	1.910
		TEMP	1.347	1.833	1.711	1.409	0.026	-1.327	-0.666	-0.175
	90182	OTHR	-3.752	-3.255	-0.030	0.473	-2.581	-0.113	0.016	0.552
		TEMP	1.856	0.556	0.778	-0.094	-4.006	0.225	-0.199	3.084
	90111	OTHR	-5.052	-3.312	0.003	-3.377	0.353	-0.368	0.113	0.137
		TEMP	0.687	3.065	-0.002	-4.393	-0.535	0.044	3.217	0.151
25 Slab EL4.65m @ RCCV	93140	OTHR	-0.520	-0.085	0.156	0.052	0.082	-0.059	0.132	-0.109
		TEMP	-0.966	2.070	3.424	-0.522	-0.407	0.286	-0.137	0.110
	93182	OTHR	-0.133	-0.246	0.040	0.006	-0.004	0.002	-0.003	-0.048
		TEMP	3.050	-3.501	-1.013	-0.380	-1.928	-0.084	0.079	1.425
	93111	OTHR	-0.316	0.069	0.027	-0.071	-0.008	-0.004	0.014	-0.005
		TEMP	-3.104	3.895	-0.106	-1.892	-0.348	-0.048	1.246	0.002
26 Slab EL17.5m @ RCCV	96144	OTHR	-0.078	0.206	0.205	0.053	0.072	-0.058	0.128	-0.102
		TEMP	0.051	3.471	3.892	-0.198	-0.171	0.135	-0.037	0.056
	96186	OTHR	0.258	-0.067	0.010	-0.010	-0.045	-0.005	-0.002	-0.008
		TEMP	3.507	-2.461	-1.416	-0.131	-0.625	-0.042	0.023	0.503
	96113	OTHR	-0.064	0.635	-0.010	-0.272	-0.009	-0.014	0.299	0.036
		TEMP	-5.649	-4.999	-0.952	-4.725	-3.463	-0.182	0.956	-0.039
27 Slab EL27.0m @ RCCV	98472	OTHR	0.464	0.091	0.124	0.299	0.497	-0.438	0.356	-0.413
		TEMP	-0.639	-1.108	5.881	-0.552	-0.184	-0.203	0.423	-0.561
	98514	OTHR	0.177	0.148	0.064	0.038	0.161	0.037	-0.021	-0.121
		TEMP	-0.797	-3.095	-1.347	-0.660	-0.340	-0.068	0.061	-0.222
	98424	OTHR	-0.093	0.490	-0.018	1.885	0.435	0.004	-1.193	-0.093
		TEMP	-11.294	-12.507	-1.614	0.502	-0.662	0.174	-6.706	-0.088
28 Pool Girder @ Storage Pool	123054	OTHR	0.377	-2.454	-0.818	0.047	0.043	0.046	-0.012	-0.023
		TEMP	0.751	-3.964	1.802	2.885	2.797	0.041	-0.399	0.710
	123154	OTHR	1.194	-0.523	-0.642	0.066	0.029	0.090	0.007	0.013
		TEMP	1.146	0.864	-0.343	2.404	1.445	-0.430	-0.139	0.303
29 Pool Girder @ Cavity	123062	OTHR	0.383	0.570	0.295	-0.046	-0.224	0.023	0.020	-0.116
		TEMP	-3.702	-0.209	-0.675	0.125	0.180	0.046	-0.120	0.099
	123162	OTHR	-1.514	0.197	0.148	-0.075	-0.052	0.013	0.086	0.028
		TEMP	-3.313	-0.169	-0.673	0.094	-0.259	0.073	-0.235	0.126
30 Pool Girder @ Fuel Pool	123067	OTHR	0.419	-2.151	1.550	0.019	-0.044	-0.067	-0.103	-0.051
		TEMP	-3.957	-6.147	-2.164	0.701	0.523	-0.099	-0.149	0.671
	123167	OTHR	0.462	-0.549	1.359	0.037	0.024	0.015	-0.027	0.009
		TEMP	-3.687	-3.040	-2.757	0.227	-0.680	-0.298	0.028	0.199
31 MS Tunnel Wall and Slab	150122	OTHR	-0.024	0.022	0.303	0.026	0.061	0.018	-0.011	-0.041
		TEMP	0.347	-0.696	2.372	1.402	4.093	-0.043	-0.760	0.539
	96611	OTHR	-0.010	0.302	-0.014	0.078	-0.047	-0.051	-0.081	0.016
		TEMP	-0.316	3.589	-0.223	-1.462	-8.773	-0.478	0.477	0.241
	98614	OTHR	-0.024	-0.150	-0.021	0.012	-0.568	-0.070	-0.057	0.033
		TEMP	-0.229	2.949	-0.177	-0.935	-13.249	0.048	0.556	0.370
32 IC/PCCS Pool Wall in NS Dir.	125051	OTHR	-0.110	-1.373	-0.942	0.003	-0.060	-0.003	0.003	-0.045
		TEMP	-0.586	-0.850	-0.349	-0.001	-0.006	0.000	-0.011	-0.008
	125151	OTHR	-0.131	-0.564	-0.768	-0.001	-0.008	-0.005	0.010	-0.002
		TEMP	-0.609	-0.738	0.611	0.033	0.071	0.015	-0.023	-0.067
	125055	OTHR	0.037	-0.215	-0.098	-0.019	-0.110	0.003	-0.038	-0.073
		TEMP	-1.342	0.274	0.019	0.007	0.033	0.002	0.014	0.013
	125155	OTHR	-0.573	-0.143	-0.083	0.007	0.030	0.006	0.035	-0.040
		TEMP	-1.754	-0.185	-0.039	0.003	0.036	-0.006	-0.076	0.004

OTHR: Loads other than thermal loads

TEMP: Thermal loads

SI to U.S. Customary units conversion (SI units are the controlling units and U.S. Customary units are for reference only):

1 MN/m = 6.852x10⁴ lbf/ft

1 MNm/m = 2.248x10⁵ lbf-ft/ft

**Table 6.3.3-2 Combined Forces and Moments: 6-min. after LOCA (1.5Pa): Winter: Load ID = 6241 (Selected Load Combination RB-8a)**

Location	Element ID		Nx (MN/m)	Ny (MN/m)	Nxy (MN/m)	Mx (MNm/m)	My (MNm/m)	Mxy (MNm/m)	Qx (MN/m)	Qy (MN/m)
18 Wall Below RCCV Bottom	6	OTHR	-1.531	-6.036	-0.265	0.034	-0.097	-0.006	0.004	0.084
		TEMP	1.177	-0.473	-0.669	0.101	1.063	-0.040	0.024	0.044
		HYDR	1.039	2.403	0.505	0.296	1.689	0.004	0.014	0.592
	13	OTHR	-1.430	-4.578	-0.001	-0.268	-1.316	0.006	-0.005	-0.330
		TEMP	0.307	-3.027	-0.689	0.408	2.284	-0.002	0.019	0.475
		HYDR	0.829	2.427	0.515	0.223	1.312	0.006	0.011	0.454
	24	OTHR	-1.296	-4.993	-0.152	-0.307	-1.874	-0.002	0.003	-0.643
		TEMP	0.412	-3.041	0.146	0.425	2.350	-0.005	-0.002	0.516
		HYDR	0.902	2.658	0.484	0.159	1.002	0.005	0.010	0.355
19 Wall Below RCCV Mid-Height	806	OTHR	-1.092	-4.839	-0.223	0.011	0.064	-0.020	-0.014	-0.067
		TEMP	1.601	-1.332	0.182	0.235	1.292	0.083	-0.053	-0.063
		HYDR	0.305	2.384	0.674	0.023	0.125	0.031	0.004	0.037
	813	OTHR	-1.485	-4.535	0.144	-0.014	0.141	-0.005	0.004	-0.025
		TEMP	1.036	-2.990	-0.508	0.175	1.290	-0.027	0.006	0.450
		HYDR	0.236	2.472	0.691	0.032	0.124	0.010	0.003	0.108
	824	OTHR	-1.775	-4.863	-0.047	0.110	0.418	0.009	-0.001	0.110
		TEMP	0.890	-3.046	0.126	0.176	1.306	0.019	0.010	0.396
		HYDR	0.259	2.709	0.633	0.018	0.131	0.014	0.002	0.067
20 Wall Below RCCV Top	1606	OTHR	-0.023	-4.224	-0.099	-0.225	-1.309	0.024	0.005	0.305
		TEMP	11.606	-2.042	0.301	-0.668	-3.250	0.099	0.085	2.306
		HYDR	0.777	2.430	0.657	0.469	2.639	0.013	0.006	0.763
	1613	OTHR	-0.217	-4.477	0.242	-0.252	-1.315	-0.003	-0.003	0.330
		TEMP	11.229	-3.474	-0.425	-0.785	-4.386	-0.008	-0.014	2.714
		HYDR	0.778	2.470	0.668	0.471	2.727	0.006	0.008	0.829
	1624	OTHR	0.186	-4.393	-0.005	-0.288	-1.754	0.006	-0.007	0.512
		TEMP	12.187	-3.970	-0.124	-0.867	-4.480	-0.001	-0.082	2.817
		HYDR	0.851	2.674	0.650	0.462	2.630	0.005	0.011	0.811
21 Exterior Wall @ EL-11.50 ~-10.50m	20011	OTHR	-1.793	-3.331	-0.710	0.177	0.937	0.018	0.035	0.302
		TEMP	3.023	3.384	0.790	0.274	1.136	0.041	-0.173	0.330
		HYDR	0.191	0.270	0.760	0.386	1.573	0.014	0.039	0.580
	20023	OTHR	-1.159	-1.480	-0.600	-0.018	-0.238	0.012	-0.055	-0.136
		TEMP	-1.459	-1.215	1.590	1.936	3.930	0.184	0.310	0.647
		HYDR	0.020	0.657	0.152	0.101	0.146	0.015	0.119	0.091
	30010	OTHR	-1.167	-2.337	-0.175	-0.186	-1.046	0.008	0.001	0.845
		TEMP	0.421	2.641	-0.135	1.081	3.585	-0.018	-0.024	-0.601
		HYDR	0.586	0.260	0.326	0.183	0.969	0.003	0.007	0.246
	30020	OTHR	-0.954	-1.671	-0.234	-0.552	-0.778	0.022	-0.148	0.330
		TEMP	-0.090	-1.196	-0.238	0.081	1.104	0.123	-0.022	-0.270
		HYDR	0.044	0.862	0.222	0.037	0.180	0.008	0.062	0.056
	40001	OTHR	-0.755	-1.833	0.384	-0.336	-1.076	-0.200	0.069	0.626
		TEMP	-0.154	-0.831	0.014	0.123	1.237	-0.081	0.114	-0.310
		HYDR	0.044	0.888	0.191	0.062	0.164	0.008	0.065	0.045
	40011	OTHR	-1.377	-3.029	-0.028	-0.224	-1.384	0.000	0.005	1.515
		TEMP	0.865	2.785	0.044	1.075	3.674	0.007	0.012	-0.638
		HYDR	0.433	0.497	0.386	0.121	0.626	0.007	0.011	0.150

OTHR: Loads other than thermal loads

TEMP: Thermal loads

HYDR: Hydrodynamic loads

SI to U.S. Customary units conversion (SI units are the controlling units and U.S. Customary units are for reference only):

1 MN/m = 6.852x10⁴ lbf/ft1 MNm/m = 2.248x10⁵ lbf-ft/ft



Table 6.3.3-2 Combined Forces and Moments: 6-min. after LOCA (1.5Pa): Winter: Load ID = 6241 (Selected Load Combination RB-8a) (Continued)

Location	Element ID		Nx (MN/m)	Ny (MN/m)	Nxy (MN/m)	Mx (MNm/m)	My (MNm/m)	Mxy (MNm/m)	Qx (MN/m)	Qy (MN/m)	
22 Exterior Wall @ EL4.65 ~6.60m	22011	OTHR	0.233	-2.732	0.623	-0.004	0.111	0.013	-0.025	0.153	
		TEMP	3.577	2.789	-0.075	-0.128	-0.161	0.049	0.032	-0.031	
		HYDR	0.300	1.068	0.853	0.018	0.123	0.027	0.004	0.227	
	22023	OTHR	-0.054	-1.629	-0.050	0.085	0.042	-0.074	0.042	0.009	
		TEMP	1.984	-3.558	-1.991	0.092	0.423	-0.047	0.570	0.405	
		HYDR	0.070	0.603	0.422	0.133	0.046	0.037	0.042	0.015	
	32010	OTHR	0.199	-1.913	0.031	-0.019	0.017	0.007	0.000	-0.098	
		TEMP	14.408	6.124	0.009	-2.798	-2.759	0.004	-0.008	0.040	
		HYDR	0.358	0.431	0.446	0.022	0.052	0.005	0.001	0.137	
	32020	OTHR	0.002	-1.891	0.248	0.000	-0.029	-0.053	0.009	0.028	
		TEMP	0.445	4.720	2.524	-0.285	-1.833	-0.377	0.922	0.167	
		HYDR	0.038	0.558	0.293	0.087	0.009	0.016	0.066	0.007	
	42001	OTHR	-0.001	-1.929	0.128	0.025	-0.061	0.059	-0.008	0.049	
		TEMP	2.451	3.607	2.534	-0.371	-1.611	-0.058	-0.794	-0.254	
		HYDR	0.066	0.583	0.326	0.112	0.010	0.011	0.045	0.003	
	42011	OTHR	-0.116	-2.159	-0.033	-0.040	-0.091	-0.005	0.004	-0.065	
		TEMP	12.432	4.405	0.143	-2.975	-2.774	0.081	0.081	0.172	
		HYDR	0.217	0.756	0.529	0.042	0.042	0.012	0.006	0.127	
23 Exterior Wall @ EL22.50 ~24.60m	24211	OTHR	0.317	-1.469	0.076	0.003	-0.055	0.014	0.005	-0.279	
		TEMP	4.177	2.901	-0.313	0.092	0.628	0.014	-0.122	1.431	
		HYDR	0.203	0.688	0.418	0.044	0.187	0.021	0.003	0.217	
	24224	OTHR	-0.020	-1.497	0.118	0.023	-0.001	-0.012	-0.029	-0.015	
		TEMP	0.340	4.642	-3.562	0.871	-0.344	-0.446	-0.824	-0.417	
		HYDR	0.034	0.693	0.342	0.139	0.094	0.035	0.068	0.098	
	34210	OTHR	0.546	-0.794	0.075	0.009	0.154	0.000	0.002	0.057	
		TEMP	15.323	4.794	-0.317	-2.778	-2.409	0.015	-0.011	0.104	
		HYDR	0.297	0.145	0.251	0.021	0.109	0.013	0.002	0.057	
	34220	OTHR	0.067	-1.342	0.038	0.047	0.025	0.003	0.031	-0.003	
		TEMP	1.721	4.437	2.297	0.980	-1.464	-0.240	1.609	0.013	
		HYDR	0.041	0.329	0.143	0.053	0.021	0.025	0.034	0.010	
	44201	OTHR	0.025	-1.389	-0.008	0.054	0.026	0.000	-0.031	-0.008	
		TEMP	1.001	5.209	0.300	0.668	-1.698	0.337	-1.911	0.044	
		HYDR	0.037	0.398	0.239	0.049	0.008	0.005	0.035	0.006	
	24 Basemat @ Wall Below RCCV	90140	OTHR	-3.158	-2.605	0.271	-0.751	-0.162	1.124	-1.864	1.611
			TEMP	1.052	1.448	1.374	0.756	-0.217	-0.971	-0.682	-0.069
			HYDR	0.719	0.518	0.569	1.410	0.998	0.310	1.000	1.030
90182		OTHR	-2.231	-2.517	-0.056	0.089	-0.479	0.032	0.038	0.397	
		TEMP	1.619	0.481	0.610	-0.246	-3.861	0.184	-0.141	2.769	
		HYDR	1.338	0.255	0.263	0.800	0.527	0.217	0.279	1.123	
90111		OTHR	-3.896	-2.337	-0.038	-1.104	0.070	-0.145	0.097	0.111	
		TEMP	0.567	2.209	-0.001	-4.129	-0.522	0.050	2.860	0.127	
		HYDR	0.202	1.158	0.073	0.385	0.640	0.171	1.039	0.271	
25 Slab EL4.65m @ RCCV	93140	OTHR	-0.327	0.109	0.281	0.113	0.123	-0.102	0.131	-0.111	
		TEMP	-0.669	2.312	4.286	-0.515	-0.395	0.287	-0.135	0.111	
		HYDR	0.264	0.274	0.326	0.053	0.039	0.052	0.015	0.018	
	93182	OTHR	0.222	-0.127	0.018	0.008	0.093	0.007	-0.004	-0.047	
		TEMP	4.229	-4.036	-1.098	-0.354	-1.829	-0.083	0.075	1.370	
		HYDR	0.401	0.097	0.114	0.036	0.061	0.006	0.007	0.153	
	93111	OTHR	-0.166	0.331	-0.030	0.044	-0.003	-0.001	-0.008	-0.006	
		TEMP	-3.602	4.956	-0.257	-1.768	-0.316	-0.047	1.178	0.000	
		HYDR	0.096	0.435	0.096	0.019	0.029	0.003	0.093	0.003	

OTHR: Loads other than thermal loads

TEMP: Thermal loads

HYDR: Hydrodynamic loads

SI to U.S. Customary units conversion (SI units are the controlling units and U.S. Customary units are for reference only):

1 MN/m = 6.852x10⁴ lbf/ft

1 MNm/m = 2.248x10⁵ lbf-ft/ft



Table 6.3.3-2 Combined Forces and Moments: 6-min. after LOCA (1.5Pa): Winter: Load ID = 6241 (Selected Load Combination RB-8a) (Continued)

Location	Element ID		Nx (MN/m)	Ny (MN/m)	Nxy (MN/m)	Mx (MNm/m)	My (MNm/m)	Mxy (MNm/m)	Qx (MN/m)	Qy (MN/m)
26 Slab EL17.5m @ RCCV	96144	OTHR	0.038	0.622	0.776	0.149	0.151	-0.117	0.140	-0.122
		TEMP	-0.269	4.712	6.965	-0.230	-0.125	0.167	-0.073	0.023
		HYDR	0.081	0.029	0.338	0.099	0.082	0.050	0.019	0.021
	96186	OTHR	0.995	-0.423	-0.105	0.012	0.106	0.001	-0.005	-0.121
		TEMP	6.688	-4.125	-1.418	-0.091	-0.316	-0.048	0.016	0.347
		HYDR	0.259	0.142	0.173	0.049	0.232	0.009	0.011	0.187
	96113	OTHR	-0.527	1.550	-0.152	0.289	0.072	-0.007	-0.064	0.008
		TEMP	-8.342	2.574	-1.682	-4.481	-2.783	-0.199	1.240	-0.059
		HYDR	0.076	0.484	0.282	0.349	0.083	0.012	0.268	0.029
27 Slab EL27.0m @ RCCV	98472	OTHR	0.594	0.662	-0.127	0.118	0.163	-0.006	0.324	-0.336
		TEMP	-0.778	-0.772	5.392	-0.313	0.031	-0.311	0.451	-0.561
		HYDR	0.140	0.069	0.211	0.086	0.112	0.056	0.069	0.071
	98514	OTHR	0.367	0.519	0.027	-0.024	-0.399	-0.005	-0.007	-0.023
		TEMP	0.397	-2.323	-1.289	-0.515	0.047	-0.042	0.045	-0.511
		HYDR	0.248	0.108	0.237	0.038	0.180	0.002	0.003	0.142
	98424	OTHR	-0.286	1.516	-0.057	0.050	0.173	-0.131	-0.585	-0.044
		TEMP	-9.063	-6.855	-1.452	1.316	-0.418	0.194	-5.559	-0.101
		HYDR	0.068	0.218	0.135	0.326	0.135	0.021	0.220	0.014
28 Pool Girder @ Storage Pool	123054	OTHR	0.221	0.665	1.288	0.068	0.030	-0.130	-0.048	-0.057
		TEMP	1.314	-2.832	1.430	2.281	2.120	0.027	-0.232	0.482
		HYDR	0.169	0.213	0.180	0.014	0.011	0.008	0.016	0.018
	123154	OTHR	0.285	-0.019	1.143	0.075	0.035	-0.140	-0.079	0.026
		TEMP	1.031	0.747	-0.407	1.925	1.145	-0.338	-0.086	0.247
		HYDR	0.305	0.042	0.174	0.020	0.013	0.023	0.009	0.001
29 Pool Girder @ Cavity	123062	OTHR	0.367	-1.036	-1.162	0.017	0.212	0.002	0.039	0.134
		TEMP	-1.254	-0.148	-0.719	0.101	0.323	0.027	0.057	0.172
		HYDR	0.185	0.022	0.140	0.013	0.016	0.006	0.007	0.004
	123162	OTHR	1.938	-0.386	-0.834	0.055	0.003	0.004	-0.033	-0.022
		TEMP	-1.691	-0.032	-0.470	0.128	-0.117	-0.003	-0.151	0.085
		HYDR	0.453	0.019	0.133	0.024	0.015	0.004	0.016	0.004
30 Pool Girder @ Fuel Pool	123067	OTHR	0.231	1.004	-1.279	-0.036	-0.070	0.018	-0.058	-0.033
		TEMP	-2.405	-6.001	-1.842	0.639	0.439	-0.117	-0.150	0.470
		HYDR	0.176	1.073	0.411	0.030	0.029	0.012	0.024	0.030
	123167	OTHR	-0.148	0.212	-1.265	-0.006	-0.058	0.034	-0.084	-0.003
		TEMP	-2.204	-2.669	-2.246	0.268	-0.449	-0.228	-0.011	0.180
		HYDR	0.478	0.311	0.449	0.019	0.008	0.008	0.012	0.005
31 MS Tunnel Wall and Slab	150122	OTHR	0.036	-0.288	0.367	0.020	0.097	0.014	-0.006	-0.067
		TEMP	0.224	-0.515	1.901	1.053	3.140	-0.007	-0.584	0.364
		HYDR	0.018	0.056	0.006	0.008	0.033	0.006	0.002	0.021
	96611	OTHR	-0.050	0.728	-0.045	0.052	-0.095	-0.055	-0.069	0.018
		TEMP	-0.447	4.103	-0.332	-1.287	-7.109	-0.423	0.426	0.209
		HYDR	0.009	0.075	0.012	0.044	0.101	0.018	0.015	0.008
	98614	OTHR	-0.017	-0.296	-0.016	-0.198	-0.998	-0.137	0.009	0.053
		TEMP	-0.187	1.989	-0.145	-0.861	-10.477	-0.011	0.470	0.303
		HYDR	0.006	0.115	0.007	0.005	0.056	0.009	0.001	0.010

OTHR: Loads other than thermal loads

TEMP: Thermal loads

HYDR: Hydrodynamic loads

SI to U.S. Customary units conversion (SI units are the controlling units and U.S. Customary units are for reference only):

1 MN/m = 6.852x10⁴ lbf/ft

1 MNm/m = 2.248x10⁵ lbf-ft/ft



Table 6.3.3-2 Combined Forces and Moments: 6-min. after LOCA (1.5Pa): Winter: Load ID = 6241 (Selected Load Combination RB-8a) (Continued)

Location	Element ID		Nx (MN/m)	Ny (MN/m)	Nxy (MN/m)	Mx (MNm/m)	My (MNm/m)	Mxy (MNm/m)	Qx (MN/m)	Qy (MN/m)
32 IC/PCCS Pool Wall in NS Dir.	125051	OTHR	0.220	0.671	0.802	-0.044	0.018	0.002	-0.034	0.035
		TEMP	-0.257	-0.976	-0.150	-0.013	-0.016	-0.001	-0.024	-0.015
		HYDR	0.017	0.095	0.061	0.003	0.002	0.000	0.003	0.001
	125151	OTHR	0.332	0.204	0.639	-0.056	-0.014	0.001	-0.056	0.003
		TEMP	-0.404	-0.680	0.529	0.018	0.055	0.012	-0.030	-0.051
		HYDR	0.038	0.053	0.068	0.004	0.001	0.000	0.004	0.000
	125055	OTHR	0.235	-0.007	-0.080	0.024	0.098	0.001	0.040	0.070
		TEMP	-0.601	0.281	0.050	0.008	0.023	0.001	0.007	0.002
		HYDR	0.048	0.044	0.093	0.001	0.001	0.000	0.001	0.001
	125155	OTHR	0.733	0.061	-0.062	-0.001	-0.039	-0.004	-0.030	0.038
		TEMP	-1.201	-0.035	0.047	0.008	0.037	-0.005	-0.061	0.002
		HYDR	0.073	0.017	0.100	0.001	0.001	0.000	0.002	0.001



Table 6.3.3-3 Combined Forces and Moments: 72-hr. after LOCA (1.5Pa): Winter: Load ID = 6441 (Selected Load Combination RB-8b)

Location	Element ID		Nx (MN/m)	Ny (MN/m)	Nxy (MN/m)	Mx (MNm/m)	My (MNm/m)	Mxy (MNm/m)	Qx (MN/m)	Qy (MN/m)
18 Wall Below RCCV Bottom	6	OTHR	-1.619	-5.773	-0.314	0.087	0.218	-0.007	0.006	0.187
		TEMP	0.745	-0.977	-0.895	0.238	1.920	-0.053	0.044	0.293
		HYDR	0.772	1.667	0.389	0.220	1.254	0.003	0.011	0.440
	13	OTHR	-1.502	-4.358	-0.016	-0.209	-0.983	0.006	-0.005	-0.227
		TEMP	-0.174	-4.065	-0.782	0.604	3.357	-0.002	0.023	0.785
		HYDR	0.611	1.684	0.393	0.167	0.980	0.004	0.008	0.338
	24	OTHR	-1.402	-4.747	-0.143	-0.245	-1.523	-0.002	0.003	-0.534
		TEMP	0.101	-3.765	0.212	0.594	3.314	-0.007	-0.003	0.779
		HYDR	0.664	1.845	0.387	0.123	0.766	0.004	0.007	0.271
19 Wall Below RCCV Mid-Height	806	OTHR	-1.066	-4.571	-0.254	0.015	0.091	-0.017	-0.015	-0.062
		TEMP	1.907	-2.149	0.225	0.307	1.688	0.090	-0.068	-0.082
		HYDR	0.214	1.640	0.518	0.017	0.091	0.024	0.003	0.027
	813	OTHR	-1.449	-4.336	0.134	-0.007	0.170	-0.004	0.007	-0.008
		TEMP	1.360	-3.986	-0.566	0.221	1.702	-0.034	0.006	0.602
		HYDR	0.164	1.703	0.531	0.023	0.089	0.010	0.003	0.080
	824	OTHR	-1.752	-4.606	-0.036	0.117	0.442	0.010	-0.002	0.126
		TEMP	1.151	-3.732	0.198	0.224	1.729	0.027	0.015	0.502
		HYDR	0.175	1.868	0.508	0.012	0.095	0.013	0.001	0.050
20 Wall Below RCCV Top	1606	OTHR	0.206	-3.965	-0.134	-0.297	-1.724	0.024	0.005	0.433
		TEMP	15.858	-3.114	0.381	-0.839	-4.009	0.124	0.101	3.042
		HYDR	0.627	1.658	0.505	0.343	1.917	0.009	0.006	0.564
	1613	OTHR	0.008	-4.314	0.233	-0.326	-1.735	-0.004	-0.003	0.467
		TEMP	15.713	-4.649	-0.420	-1.005	-5.538	-0.011	-0.016	3.612
		HYDR	0.620	1.694	0.502	0.340	1.957	0.004	0.008	0.601
	1624	OTHR	0.437	-4.132	0.002	-0.364	-2.194	0.007	-0.006	0.657
		TEMP	16.688	-4.842	-0.107	-1.115	-5.549	0.001	-0.106	3.698
		HYDR	0.683	1.834	0.505	0.336	1.898	0.003	0.010	0.592
21 Exterior Wall @ EL-11.50 ~10.50m	20011	OTHR	-1.773	-3.231	-0.705	0.202	1.028	0.020	0.031	0.330
		TEMP	3.314	4.817	0.922	0.447	1.837	0.052	-0.225	0.576
		HYDR	0.135	0.207	0.589	0.279	1.135	0.010	0.029	0.418
	20023	OTHR	-1.158	-1.487	-0.611	-0.025	-0.231	0.012	-0.054	-0.133
		TEMP	-1.453	-1.169	1.549	1.890	4.020	0.180	0.322	0.683
		HYDR	0.016	0.467	0.114	0.074	0.109	0.011	0.091	0.068
	30010	OTHR	-1.125	-2.318	-0.177	-0.153	-0.884	0.007	0.001	0.811
		TEMP	0.688	3.733	-0.258	1.289	4.763	-0.022	-0.031	-0.865
		HYDR	0.416	0.191	0.261	0.135	0.710	0.003	0.006	0.180
	30020	OTHR	-0.943	-1.710	-0.239	-0.564	-0.772	0.026	-0.145	0.329
		TEMP	-0.058	-1.477	-0.392	0.021	1.209	0.144	-0.026	-0.282
		HYDR	0.034	0.601	0.161	0.028	0.126	0.006	0.045	0.038
	40001	OTHR	-0.749	-1.866	0.405	-0.348	-1.063	-0.202	0.068	0.623
		TEMP	-0.090	-1.141	0.056	0.039	1.330	-0.097	0.105	-0.322
		HYDR	0.034	0.620	0.140	0.046	0.114	0.006	0.047	0.031
	40011	OTHR	-1.377	-2.988	-0.028	-0.188	-1.203	0.001	0.005	1.476
		TEMP	1.295	3.630	0.051	1.243	4.654	0.011	0.015	-0.844
		HYDR	0.324	0.343	0.301	0.092	0.471	0.005	0.008	0.113

OTHR: Loads other than thermal loads

TEMP: Thermal loads

HYDR: Hydrodynamic loads

SI to U.S. Customary units conversion (SI units are the controlling units and U.S. Customary units are for reference only):

1 MN/m = 6.852x10⁴ lbf/ft

1 MNm/m = 2.248x10⁵ lbf-ft/ft

**Table 6.3.3-3 Combined Forces and Moments: 72-hr. after LOCA (1.5Pa): Winter: Load ID = 6441 (Selected Load Combination RB-8b) (Continued)**

Location	Element ID		Nx (MN/m)	Ny (MN/m)	Nxy (MN/m)	Mx (MNm/m)	My (MNm/m)	Mxy (MNm/m)	Qx (MN/m)	Qy (MN/m)
22 Exterior Wall @ EL4.65 ~6.60m	22011	OTHR	0.339	-2.651	0.604	-0.004	0.125	0.014	-0.027	0.174
		TEMP	5.080	4.474	-0.209	-0.175	-0.228	0.067	0.045	0.074
		HYDR	0.227	0.763	0.623	0.012	0.082	0.020	0.003	0.156
	22023	OTHR	-0.043	-1.614	-0.038	0.115	0.050	-0.081	0.033	0.007
		TEMP	2.211	-3.114	-2.141	0.528	0.492	-0.052	0.386	0.393
		HYDR	0.050	0.414	0.306	0.106	0.032	0.026	0.029	0.011
	32010	OTHR	0.331	-1.891	0.025	-0.020	0.035	0.009	0.000	-0.125
		TEMP	16.739	7.724	-0.075	-2.893	-3.003	-0.001	-0.014	0.022
		HYDR	0.268	0.301	0.334	0.019	0.042	0.004	0.001	0.100
	32020	OTHR	0.015	-1.865	0.304	0.024	-0.022	-0.065	0.025	0.031
		TEMP	0.653	4.869	2.518	0.104	-1.860	-0.395	1.226	0.199
		HYDR	0.030	0.375	0.221	0.070	0.007	0.013	0.052	0.005
	42001	OTHR	0.013	-1.892	0.155	0.056	-0.055	0.063	-0.019	0.051
		TEMP	2.720	3.801	2.644	0.130	-1.563	-0.051	-0.998	-0.239
		HYDR	0.050	0.394	0.243	0.090	0.007	0.009	0.036	0.002
42011	OTHR	-0.007	-2.066	-0.022	-0.044	-0.083	-0.007	0.004	-0.089	
	TEMP	14.110	5.515	0.234	-3.164	-3.046	0.073	0.090	0.169	
	HYDR	0.174	0.524	0.390	0.035	0.041	0.009	0.005	0.100	
23 Exterior Wall @ EL22.50 ~24.60m	24211	OTHR	0.432	-1.384	0.073	0.019	0.042	0.016	0.006	-0.324
		TEMP	6.073	5.669	-0.239	0.176	0.982	0.008	-0.147	1.336
		HYDR	0.139	0.484	0.307	0.030	0.133	0.015	0.003	0.151
	24224	OTHR	-0.016	-1.578	0.073	0.018	0.007	-0.005	-0.020	-0.014
		TEMP	1.011	5.349	-3.664	1.966	0.071	-0.637	-1.563	-0.323
		HYDR	0.024	0.484	0.237	0.097	0.065	0.024	0.049	0.069
	34210	OTHR	0.665	-0.773	0.079	0.011	0.196	-0.001	0.001	0.070
		TEMP	21.813	5.545	-0.581	-2.903	-2.819	0.035	-0.002	-0.128
		HYDR	0.213	0.101	0.181	0.014	0.075	0.009	0.001	0.040
	34220	OTHR	0.072	-1.429	0.075	0.047	0.037	0.006	0.029	-0.005
		TEMP	2.794	5.432	4.414	2.629	-1.178	-0.711	2.571	0.094
		HYDR	0.028	0.230	0.103	0.036	0.015	0.017	0.022	0.007
	44201	OTHR	0.024	-1.451	0.059	0.057	0.035	-0.003	-0.027	-0.009
		TEMP	1.793	6.586	0.562	2.230	-1.491	0.539	-2.967	0.044
		HYDR	0.026	0.278	0.167	0.034	0.005	0.003	0.024	0.004
24 Basemat @ Wall Below RCCV	90140	OTHR	-3.166	-2.562	0.350	-0.504	0.036	0.808	-1.844	1.559
		TEMP	0.838	1.691	1.751	-0.171	-1.046	-1.095	-1.135	0.139
		HYDR	0.511	0.380	0.435	1.016	0.711	0.265	0.709	0.729
	90182	OTHR	-2.067	-2.502	-0.061	-0.009	-0.124	0.075	0.031	0.375
		TEMP	1.908	0.687	0.488	-0.873	-5.527	0.260	-0.110	3.825
		HYDR	0.956	0.181	0.195	0.570	0.440	0.179	0.209	0.795
	90111	OTHR	-3.876	-2.251	-0.048	-0.757	-0.019	-0.097	0.077	0.107
		TEMP	0.733	2.908	-0.011	-5.322	-1.147	0.107	3.687	0.151
		HYDR	0.135	0.851	0.058	0.342	0.458	0.143	0.736	0.209
25 Slab EL4.65m @ RCCV	93140	OTHR	-0.301	0.152	0.320	0.126	0.132	-0.112	0.133	-0.113
		TEMP	-0.383	3.018	5.804	-0.739	-0.564	0.413	-0.192	0.163
		HYDR	0.199	0.202	0.263	0.038	0.028	0.035	0.011	0.013
	93182	OTHR	0.301	-0.109	0.015	0.007	0.109	0.008	-0.004	-0.040
		TEMP	6.161	-5.154	-1.518	-0.481	-2.508	-0.114	0.105	1.903
		HYDR	0.304	0.089	0.090	0.026	0.045	0.004	0.005	0.109
	93111	OTHR	-0.148	0.401	-0.042	0.061	-0.004	-0.001	-0.005	-0.006
		TEMP	-4.494	6.820	-0.448	-2.369	-0.414	-0.066	1.594	0.001
		HYDR	0.094	0.336	0.073	0.014	0.021	0.002	0.067	0.002

OTHR: Loads other than thermal loads

TEMP: Thermal loads

HYDR: Hydrodynamic loads

SI to U.S. Customary units conversion (SI units are the controlling units and U.S. Customary units are for reference only):

1 MN/m = 6.852x10⁴ lbf/ft1 MNm/m = 2.248x10⁵ lbf-ft/ft

**Table 6.3.3-3 Combined Forces and Moments: 72-hr. after LOCA (1.5Pa): Winter: Load ID = 6441 (Selected Load Combination RB-8b) (Continued)**

Location	Element ID		Nx (MN/m)	Ny (MN/m)	Nxy (MN/m)	Mx (MNm/m)	My (MNm/m)	Mxy (MNm/m)	Qx (MN/m)	Qy (MN/m)
26 Slab EL17.5m @ RCCV	96144	OTHR	0.060	0.743	0.907	0.170	0.165	-0.128	0.145	-0.126
		TEMP	0.733	5.839	8.138	-0.232	-0.178	0.174	-0.043	0.066
		HYDR	0.059	0.024	0.247	0.068	0.056	0.034	0.013	0.015
	96186	OTHR	1.173	-0.501	-0.139	0.017	0.135	0.004	-0.006	-0.146
		TEMP	9.999	-4.559	-2.165	-0.150	-0.675	-0.057	0.023	0.638
		HYDR	0.185	0.103	0.126	0.034	0.159	0.006	0.008	0.128
	96113	OTHR	-0.637	1.788	-0.200	0.373	0.087	0.004	-0.131	0.004
		TEMP	-9.165	5.149	-1.811	-4.378	-2.755	-0.237	1.010	-0.100
		HYDR	0.059	0.334	0.201	0.240	0.058	0.009	0.185	0.020
27 Slab EL27.0m @ RCCV	98472	OTHR	0.598	0.749	-0.160	0.093	0.116	0.074	0.310	-0.312
		TEMP	-3.645	-3.148	5.906	-1.729	-1.315	-0.297	0.534	-0.685
		HYDR	0.100	0.049	0.144	0.060	0.079	0.039	0.048	0.050
	98514	OTHR	0.388	0.537	0.023	-0.035	-0.502	-0.013	-0.005	-0.005
		TEMP	-2.902	-2.765	-1.440	-1.895	-1.503	-0.079	0.078	-0.381
		HYDR	0.171	0.075	0.171	0.027	0.126	0.002	0.002	0.099
	98424	OTHR	-0.327	1.735	-0.065	-0.312	0.121	-0.158	-0.473	-0.035
		TEMP	-8.825	-1.775	-2.345	3.485	0.429	0.374	-5.774	-0.156
		HYDR	0.045	0.153	0.099	0.229	0.096	0.015	0.157	0.010
28 Pool Girder @ Storage Pool	123054	OTHR	0.181	1.271	1.721	0.070	0.026	-0.166	-0.053	-0.068
		TEMP	3.583	1.298	2.382	3.613	2.453	-0.343	0.113	0.317
		HYDR	0.115	0.149	0.128	0.009	0.008	0.005	0.012	0.012
	123154	OTHR	0.064	0.064	1.522	0.074	0.040	-0.189	-0.096	0.030
		TEMP	3.638	3.575	-2.911	3.372	1.303	-0.374	-0.255	0.413
		HYDR	0.211	0.029	0.122	0.014	0.009	0.016	0.006	0.001
29 Pool Girder @ Cavity	123062	OTHR	0.341	-1.396	-1.460	0.027	0.300	-0.001	0.043	0.174
		TEMP	0.505	0.115	-1.385	3.836	3.893	0.008	0.034	0.188
		HYDR	0.127	0.014	0.099	0.009	0.011	0.004	0.005	0.003
	123162	OTHR	2.594	-0.537	-1.030	0.081	0.023	0.000	-0.058	-0.029
		TEMP	1.929	0.409	-1.840	3.803	2.820	0.092	-0.288	0.644
		HYDR	0.315	0.013	0.093	0.017	0.011	0.003	0.011	0.003
30 Pool Girder @ Fuel Pool	123067	OTHR	0.174	1.598	-1.845	-0.044	-0.074	0.042	-0.040	-0.043
		TEMP	-2.101	-7.271	-3.005	3.592	3.540	-0.636	0.317	0.815
		HYDR	0.121	0.753	0.285	0.022	0.021	0.008	0.017	0.021
	123167	OTHR	-0.295	0.333	-1.783	-0.009	-0.064	0.036	-0.080	0.002
		TEMP	-0.679	-2.776	-3.132	2.749	1.834	-0.242	-0.176	0.616
		HYDR	0.336	0.218	0.312	0.013	0.006	0.006	0.008	0.003
31 MS Tunnel Wall and Slab	150122	OTHR	0.048	-0.350	0.382	0.019	0.105	0.014	-0.006	-0.073
		TEMP	0.316	-0.711	1.797	0.940	3.101	0.011	-0.551	0.426
		HYDR	0.012	0.039	0.004	0.006	0.024	0.004	0.002	0.014
	96611	OTHR	-0.060	0.825	-0.052	0.047	-0.107	-0.056	-0.067	0.019
		TEMP	-0.557	4.662	-0.414	-1.254	-7.116	-0.406	0.420	0.206
		HYDR	0.007	0.052	0.008	0.031	0.072	0.013	0.011	0.005
	98614	OTHR	-0.016	-0.324	-0.016	-0.240	-1.090	-0.151	0.022	0.057
		TEMP	-0.043	0.725	-0.043	-0.850	-9.922	-0.018	0.459	0.307
		HYDR	0.004	0.081	0.005	0.004	0.040	0.006	0.001	0.007

OTHR: Loads other than thermal loads

TEMP: Thermal loads

HYDR: Hydrodynamic loads

SI to U.S. Customary units conversion (SI units are the controlling units and U.S. Customary units are for reference only):

1 MN/m = 6.852x10⁴ lbf/ft1 MNm/m = 2.248x10⁵ lbf-ft/ft

**Table 6.3.3-3 Combined Forces and Moments: 72-hr. after LOCA (1.5Pa): Winter: Load ID = 6441 (Selected Load Combination RB-8b) (Continued)**

Location	Element ID		Nx (MN/m)	Ny (MN/m)	Nxy (MN/m)	Mx (MNm/m)	My (MNm/m)	Mxy (MNm/m)	Qx (MN/m)	Qy (MN/m)
32 IC/PCCS Pool Wall in NS Dir.	125051	OTHR	0.275	1.012	1.148	-0.051	0.034	0.003	-0.041	0.049
		TEMP	-2.425	-2.173	-0.782	0.093	0.096	-0.014	0.023	0.036
		HYDR	0.011	0.065	0.043	0.002	0.001	0.000	0.002	0.001
	125151	OTHR	0.410	0.298	0.920	-0.064	-0.011	0.002	-0.068	0.005
		TEMP	-2.083	-1.572	1.896	0.131	0.140	0.029	0.019	-0.082
		HYDR	0.026	0.037	0.048	0.003	0.001	0.000	0.003	0.000
	125055	OTHR	0.260	-0.040	-0.079	0.032	0.139	0.001	0.054	0.096
		TEMP	-4.971	-0.309	0.162	0.019	0.097	0.004	-0.047	-0.011
		HYDR	0.033	0.031	0.066	0.001	0.001	0.000	0.001	0.000
	125155	OTHR	0.974	0.033	-0.057	-0.002	-0.050	-0.006	-0.046	0.055
		TEMP	-4.973	-0.680	0.046	0.014	0.094	-0.011	-0.133	0.027
		HYDR	0.052	0.012	0.070	0.001	0.000	0.000	0.001	0.001



**Table 6.3.3-4 Combined Forces and Moments: LOCA + SSE: 6-min. after: Winter: Load
ID = 7241 (Site-Specific Seismic Load Combination RB-9a)**

Location	Element ID		Nx (MN/m)	Ny (MN/m)	Nxy (MN/m)	Mx (MNm/m)	My (MNm/m)	Mxy (MNm/m)	Qx (MN/m)	Qy (MN/m)
18 Wall Below RCCV Bottom	6	OTHR	-1.400	-6.451	-0.191	-0.048	-0.575	-0.004	0.000	-0.074
		TEMP	1.177	-0.473	-0.669	0.101	1.063	-0.040	0.024	0.044
		SEIS	2.942	7.596	0.819	0.455	2.879	0.060	0.114	1.022
		HYDR	0.730	1.683	0.349	0.209	1.193	0.003	0.010	0.417
	13	OTHR	-1.324	-4.936	0.021	-0.357	-1.820	0.006	-0.005	-0.486
		TEMP	0.307	-3.027	-0.689	0.408	2.284	-0.002	0.019	0.475
		SEIS	2.990	6.667	0.680	0.657	3.767	0.017	0.025	1.312
		HYDR	0.582	1.701	0.362	0.158	0.930	0.004	0.008	0.321
	24	OTHR	-1.138	-5.397	-0.165	-0.401	-2.405	-0.001	0.002	-0.807
		TEMP	0.412	-3.041	0.146	0.425	2.350	-0.005	-0.002	0.516
		SEIS	2.106	7.069	1.196	0.659	3.721	0.015	0.022	1.154
		HYDR	0.638	1.871	0.334	0.114	0.717	0.003	0.007	0.254
19 Wall Below RCCV Mid-Height	806	OTHR	-1.128	-5.265	-0.171	0.007	0.032	-0.023	-0.013	-0.078
		TEMP	1.601	-1.332	0.182	0.235	1.292	0.083	-0.053	-0.063
		SEIS	2.715	7.082	1.180	0.103	0.122	0.103	0.064	0.143
		HYDR	0.209	1.673	0.467	0.016	0.090	0.022	0.003	0.026
	813	OTHR	-1.535	-4.861	0.161	-0.021	0.106	-0.007	0.001	-0.051
		TEMP	1.036	-2.990	-0.508	0.175	1.290	-0.027	0.006	0.450
		SEIS	2.309	6.799	0.796	0.203	0.487	0.049	0.027	0.250
		HYDR	0.162	1.735	0.485	0.023	0.089	0.007	0.002	0.076
	824	OTHR	-1.804	-5.285	-0.062	0.101	0.391	0.009	-0.001	0.084
		TEMP	0.890	-3.046	0.126	0.176	1.306	0.019	0.010	0.396
		SEIS	2.360	7.372	1.689	0.244	0.499	0.027	0.013	0.267
		HYDR	0.180	1.909	0.438	0.013	0.095	0.010	0.001	0.048
20 Wall Below RCCV Top	1606	OTHR	-0.318	-4.636	-0.041	-0.130	-0.762	0.024	0.005	0.138
		TEMP	11.606	-2.042	0.301	-0.668	-3.250	0.099	0.085	2.306
		SEIS	2.278	6.409	2.761	0.223	1.075	0.123	0.028	0.360
		HYDR	0.573	1.710	0.449	0.335	1.886	0.009	0.005	0.547
	1613	OTHR	-0.509	-4.748	0.254	-0.155	-0.762	-0.002	-0.003	0.151
		TEMP	11.229	-3.474	-0.425	-0.785	-4.386	-0.008	-0.014	2.714
		SEIS	1.605	6.417	1.899	0.240	1.485	0.033	0.018	0.592
		HYDR	0.570	1.738	0.465	0.336	1.944	0.004	0.006	0.592
	1624	OTHR	-0.137	-4.829	-0.014	-0.189	-1.171	0.006	-0.007	0.324
		TEMP	12.187	-3.970	-0.124	-0.867	-4.480	-0.001	-0.082	2.817
		SEIS	1.940	6.999	2.725	0.198	1.333	0.043	0.033	0.536
		HYDR	0.624	1.887	0.447	0.331	1.880	0.003	0.008	0.581

OTHR: Loads other than thermal, seismic and hydrodynamic loads

TEMP: Thermal loads

SEIS: Seismic loads

HYDR: Hydrodynamic loads

SI to U.S. Customary units conversion (SI units are the controlling units and U.S. Customary units are for reference only):

1 MN/m = 6.852x10⁴ lbf/ft

1 MNm/m = 2.248x10⁵ lbf-ft/ft

**Table 6.3.3-4 Combined Forces and Moments: LOCA + SSE: 6-min. after: Winter: Load ID = 7241 (Site-Specific Seismic Load Combination RB-9a) (Continued)**

Location	Element ID		Nx (MN/m)	Ny (MN/m)	Nxy (MN/m)	Mx (MNm/m)	My (MNm/m)	Mxy (MNm/m)	Qx (MN/m)	Qy (MN/m)
21 Exterior Wall @ EL-11.50 ~10.50m	20011	OTHR	-1.819	-3.469	-0.717	0.141	0.804	0.015	0.039	0.262
		TEMP	3.023	3.384	0.790	0.274	1.136	0.041	-0.173	0.330
		SEIS	2.212	3.459	2.195	0.719	2.803	0.032	0.055	1.107
		HYDR	0.134	0.191	0.521	0.270	1.101	0.010	0.028	0.406
	20023	OTHR	-1.161	-1.469	-0.585	-0.008	-0.247	0.013	-0.057	-0.141
		TEMP	-1.459	-1.215	1.590	1.936	3.930	0.184	0.310	0.647
		SEIS	1.327	1.953	0.794	0.532	0.597	0.101	0.629	0.404
		HYDR	0.014	0.456	0.106	0.070	0.102	0.010	0.083	0.063
	30010	OTHR	-1.224	-2.354	-0.170	-0.234	-1.284	0.011	0.002	0.895
		TEMP	0.421	2.641	-0.135	1.081	3.585	-0.018	-0.024	-0.601
		SEIS	3.058	1.953	1.026	0.436	2.379	0.029	0.027	0.869
		HYDR	0.411	0.177	0.226	0.129	0.686	0.002	0.005	0.174
	30020	OTHR	-0.970	-1.615	-0.225	-0.535	-0.786	0.017	-0.153	0.330
		TEMP	-0.090	-1.196	-0.238	0.081	1.104	0.123	-0.022	-0.270
		SEIS	0.847	1.721	1.415	0.490	0.912	0.160	0.406	0.430
		HYDR	0.030	0.605	0.155	0.026	0.126	0.006	0.044	0.039
	40001	OTHR	-0.763	-1.785	0.353	-0.320	-1.095	-0.197	0.070	0.629
		TEMP	-0.154	-0.831	0.014	0.123	1.237	-0.081	0.114	-0.310
		SEIS	0.790	1.806	1.368	0.537	1.002	0.216	0.330	0.403
		HYDR	0.030	0.624	0.134	0.044	0.114	0.006	0.045	0.032
40011	OTHR	-1.371	-3.077	-0.028	-0.278	-1.648	-0.002	0.005	1.572	
	TEMP	0.865	2.785	0.044	1.075	3.674	0.007	0.012	-0.638	
	SEIS	1.584	2.452	1.304	0.425	2.280	0.016	0.021	0.762	
	HYDR	0.301	0.346	0.268	0.087	0.448	0.005	0.007	0.108	
22 Exterior Wall @ EL4.65 ~6.60m	22011	OTHR	0.107	-2.850	0.649	-0.005	0.094	0.012	-0.024	0.133
		TEMP	3.577	2.789	-0.075	-0.128	-0.161	0.049	0.032	-0.031
		SEIS	1.226	5.546	4.092	0.153	0.818	0.090	0.050	0.715
		HYDR	0.217	0.746	0.584	0.012	0.084	0.019	0.003	0.159
	22023	OTHR	-0.068	-1.637	-0.059	0.049	0.031	-0.067	0.053	0.011
		TEMP	1.984	-3.558	-1.991	0.092	0.423	-0.047	0.570	0.405
		SEIS	0.750	5.668	3.527	0.299	0.222	0.141	0.357	0.148
		HYDR	0.049	0.415	0.288	0.097	0.032	0.026	0.029	0.010
	32010	OTHR	0.037	-1.940	0.038	-0.019	-0.007	0.005	0.000	-0.068
		TEMP	14.408	6.124	0.009	-2.798	-2.759	0.004	-0.008	0.040
		SEIS	1.206	3.569	3.077	0.057	0.356	0.022	0.004	0.219
		HYDR	0.256	0.299	0.303	0.016	0.039	0.004	0.001	0.099
	32020	OTHR	-0.012	-1.900	0.169	-0.028	-0.038	-0.040	-0.009	0.023
		TEMP	0.445	4.720	2.524	-0.285	-1.833	-0.377	0.922	0.167
		SEIS	0.525	6.282	2.371	0.441	0.184	0.173	0.243	0.069
		HYDR	0.028	0.390	0.200	0.064	0.007	0.011	0.048	0.005
	42001	OTHR	-0.017	-1.953	0.081	-0.012	-0.070	0.055	0.004	0.046
		TEMP	2.451	3.607	2.534	-0.371	-1.611	-0.058	-0.794	-0.254
		SEIS	0.379	6.366	2.517	0.289	0.162	0.239	0.354	0.049
		HYDR	0.048	0.408	0.224	0.083	0.007	0.008	0.033	0.002
	42011	OTHR	-0.245	-2.297	-0.043	-0.036	-0.101	-0.003	0.004	-0.040
		TEMP	12.432	4.405	0.143	-2.975	-2.774	0.081	0.081	0.172
		SEIS	1.202	3.902	3.709	0.069	0.408	0.038	0.048	0.184
		HYDR	0.159	0.532	0.361	0.031	0.033	0.008	0.004	0.093

OTHR: Loads other than thermal, seismic and hydrodynamic loads

TEMP: Thermal loads

SEIS: Seismic loads

HYDR: Hydrodynamic loads

SI to U.S. Customary units conversion (SI units are the controlling units and U.S. Customary units are for reference only):

1 MN/m = 6.852x10⁴ lbf/ft1 MNm/m = 2.248x10⁵ lbf-ft/ft



Table 6.3.3-4 Combined Forces and Moments: LOCA + SSE: 6-min. after: Winter: Load ID = 7241 (Site-Specific Seismic Load Combination RB-9a) (Continued)

Location	Element ID		Nx (MN/m)	Ny (MN/m)	Nxy (MN/m)	Mx (MNm/m)	My (MNm/m)	Mxy (MNm/m)	Qx (MN/m)	Qy (MN/m)
23 Exterior Wall @ EL.22.50 ~24.60m	24211	OTHR	0.150	-1.585	0.081	-0.023	-0.200	0.012	0.003	-0.207
		TEMP	4.177	2.901	-0.313	0.092	0.628	0.014	-0.122	1.431
		SEIS	0.931	4.603	3.707	0.152	0.641	0.042	0.007	0.711
		HYDR	0.142	0.484	0.283	0.030	0.133	0.015	0.002	0.151
	24224	OTHR	-0.026	-1.353	0.185	0.028	-0.018	-0.022	-0.043	-0.022
		TEMP	0.340	4.642	-3.562	0.871	-0.344	-0.446	-0.824	-0.417
		SEIS	0.511	8.980	3.791	0.769	1.137	0.261	0.367	1.272
		HYDR	0.024	0.485	0.236	0.095	0.064	0.024	0.047	0.068
	34210	OTHR	0.361	-0.815	0.071	0.004	0.075	0.000	0.003	0.033
		TEMP	15.323	4.794	-0.317	-2.778	-2.409	0.015	-0.011	0.104
		SEIS	1.058	1.986	3.456	0.103	0.608	0.012	0.025	0.194
	34220	HYDR	0.202	0.102	0.171	0.015	0.077	0.009	0.001	0.041
		OTHR	0.058	-1.197	-0.027	0.047	0.006	0.000	0.033	-0.001
		TEMP	1.721	4.437	2.297	0.980	-1.464	-0.240	1.609	0.013
		SEIS	0.159	3.297	2.210	0.111	0.114	0.027	0.079	0.025
	44201	HYDR	0.028	0.231	0.098	0.036	0.015	0.017	0.023	0.007
OTHR		0.024	-1.285	-0.109	0.049	0.012	0.004	-0.035	-0.006	
TEMP		1.001	5.209	0.300	0.668	-1.698	0.337	-1.911	0.044	
SEIS		0.167	3.795	2.479	0.068	0.041	0.040	0.109	0.024	
24 Basemat @ Wall Below RCCV	90140	HYDR	0.026	0.280	0.164	0.033	0.005	0.003	0.024	0.004
		OTHR	-3.142	-2.669	0.148	-1.147	-0.481	1.613	-1.900	1.694
		TEMP	1.052	1.448	1.374	0.756	-0.217	-0.971	-0.682	-0.069
		SEIS	2.801	1.113	1.986	3.720	2.589	3.423	2.095	2.337
	90182	HYDR	0.511	0.359	0.401	0.987	0.702	0.218	0.702	0.721
		OTHR	-2.479	-2.537	-0.046	0.232	-1.054	-0.033	0.049	0.446
		TEMP	1.619	0.481	0.610	-0.246	-3.861	0.184	-0.141	2.769
		SEIS	2.544	0.415	1.472	1.264	3.140	0.509	0.312	2.146
	90111	HYDR	0.940	0.180	0.184	0.566	0.378	0.154	0.197	0.791
		OTHR	-3.922	-2.463	-0.021	-1.672	0.197	-0.220	0.145	0.119
		TEMP	0.567	2.209	-0.001	-4.129	-0.522	0.050	2.860	0.127
		SEIS	0.479	1.371	1.951	3.034	1.044	0.680	1.765	0.565
		HYDR	0.141	0.811	0.051	0.274	0.454	0.121	0.736	0.189

OTHR: Loads other than thermal, seismic and hydrodynamic loads

TEMP: Thermal loads

SEIS: Seismic loads

HYDR: Hydrodynamic loads

SI to U.S. Customary units conversion (SI units are the controlling units and U.S. Customary units are for reference only):

1 MN/m = 6.852x10⁴ lbf/ft

1 MNm/m = 2.248x10⁵ lbf-ft/ft



Table 6.3.3-4 Combined Forces and Moments: LOCA + SSE: 6-min. after: Winter: Load ID = 7241 (Site-Specific Seismic Load Combination RB-9a) (Continued)

Location	Element ID		Nx (MN/m)	Ny (MN/m)	Nxy (MN/m)	Mx (MNm/m)	My (MNm/m)	Mxy (MNm/m)	Qx (MN/m)	Qy (MN/m)
25 Slab EL4.65m @ RCCV	93140	OTHR	-0.355	0.056	0.234	0.095	0.110	-0.088	0.129	-0.109
		TEMP	-0.669	2.312	4.286	-0.515	-0.395	0.287	-0.135	0.111
		SEIS	1.713	0.333	0.267	0.269	0.210	0.146	0.126	0.111
		HYDR	0.182	0.196	0.238	0.036	0.027	0.036	0.010	0.012
	93182	OTHR	0.125	-0.144	0.022	0.009	0.070	0.006	-0.004	-0.055
		TEMP	4.229	-4.036	-1.098	-0.354	-1.829	-0.083	0.075	1.370
		SEIS	0.313	0.148	0.131	0.128	0.637	0.030	0.030	0.587
		HYDR	0.290	0.073	0.082	0.025	0.042	0.004	0.005	0.108
	93111	OTHR	-0.185	0.248	-0.015	0.018	-0.002	-0.001	-0.010	-0.005
		TEMP	-3.602	4.956	-0.257	-1.768	-0.316	-0.047	1.178	0.000
		SEIS	0.185	0.254	0.154	0.537	0.097	0.022	0.434	0.005
		HYDR	0.073	0.316	0.068	0.013	0.021	0.002	0.066	0.002
26 Slab EL17.5m @ RCCV	96144	OTHR	-0.003	0.471	0.581	0.117	0.124	-0.097	0.133	-0.113
		TEMP	-0.269	4.712	6.965	-0.230	-0.125	0.167	-0.073	0.023
		SEIS	0.611	0.374	0.224	0.221	0.196	0.136	0.109	0.086
		HYDR	0.056	0.021	0.228	0.068	0.057	0.034	0.013	0.015
	96186	OTHR	0.748	-0.307	-0.071	0.006	0.060	0.000	-0.004	-0.086
		TEMP	6.688	-4.125	-1.418	-0.091	-0.316	-0.048	0.016	0.347
		SEIS	0.532	0.188	0.210	0.115	0.599	0.026	0.031	0.481
		HYDR	0.176	0.097	0.118	0.035	0.162	0.006	0.008	0.130
	96113	OTHR	-0.374	1.228	-0.107	0.112	0.048	-0.008	0.047	0.016
		TEMP	-8.342	2.574	-1.682	-4.481	-2.783	-0.199	1.240	-0.059
		SEIS	0.090	1.066	0.667	1.234	0.140	0.053	1.033	0.124
		HYDR	0.054	0.335	0.192	0.246	0.059	0.009	0.189	0.020
27 Slab EL27.0m @ RCCV	98472	OTHR	0.538	0.462	-0.046	0.176	0.270	-0.145	0.331	-0.357
		TEMP	-0.778	-0.772	5.392	-0.313	0.031	-0.311	0.451	-0.561
		SEIS	0.794	0.877	0.373	0.464	0.714	0.577	0.448	0.527
		HYDR	0.100	0.049	0.146	0.061	0.079	0.039	0.048	0.051
	98514	OTHR	0.298	0.383	0.033	-0.004	-0.213	0.008	-0.011	-0.055
		TEMP	0.397	-2.323	-1.289	-0.515	0.047	-0.042	0.045	-0.511
		SEIS	0.669	0.096	0.371	0.189	1.155	0.076	0.047	0.772
		HYDR	0.170	0.075	0.161	0.027	0.127	0.001	0.002	0.100
	98424	OTHR	-0.221	1.168	-0.045	0.656	0.262	-0.086	-0.778	-0.060
		TEMP	-9.063	-6.855	-1.452	1.316	-0.418	0.194	-5.559	-0.101
		SEIS	1.057	1.196	3.487	2.644	0.649	0.155	1.814	0.149
		HYDR	0.047	0.148	0.092	0.231	0.096	0.014	0.157	0.010

OTHR: Loads other than thermal, seismic and hydrodynamic loads

TEMP: Thermal loads

SEIS: Seismic loads

HYDR: Hydrodynamic loads

SI to U.S. Customary units conversion (SI units are the controlling units and U.S. Customary units are for reference only):

1 MN/m = 6.852x10⁴ lbf/ft

1 MNm/m = 2.248x10⁵ lbf-ft/ft



Table 6.3.3-4 Combined Forces and Moments: LOCA + SSE: 6-min. after: Winter: Load ID = 7241 (Site-Specific Seismic Load Combination RB-9a) (Continued)

Location	Element ID		Nx (MN/m)	Ny (MN/m)	Nxy (MN/m)	Mx (MNm/m)	My (MNm/m)	Mxy (MNm/m)	Qx (MN/m)	Qy (MN/m)
28 Pool Girder @ Storage Pool	123054	OTHR	0.281	-0.342	0.594	0.061	0.034	-0.072	-0.036	-0.044
		TEMP	1.314	-2.832	1.430	2.281	2.120	0.027	-0.232	0.482
		SEIS	0.569	3.326	1.105	0.205	0.094	0.091	0.049	0.123
		HYDR	0.118	0.151	0.128	0.010	0.008	0.005	0.012	0.012
	123154	OTHR	0.616	-0.173	0.550	0.073	0.032	-0.064	-0.050	0.021
		TEMP	1.031	0.747	-0.407	1.925	1.145	-0.338	-0.086	0.247
		SEIS	1.837	0.841	1.008	0.167	0.070	0.158	0.061	0.020
		HYDR	0.215	0.029	0.123	0.014	0.009	0.016	0.006	0.001
29 Pool Girder @ Cavity	123062	OTHR	0.376	-0.508	-0.685	-0.003	0.071	0.008	0.031	0.052
		TEMP	-1.254	-0.148	-0.719	0.101	0.323	0.027	0.057	0.172
		SEIS	0.576	1.124	0.540	0.154	0.283	0.046	0.080	0.160
		HYDR	0.126	0.015	0.096	0.008	0.011	0.004	0.005	0.003
	123162	OTHR	0.829	-0.194	-0.510	0.013	-0.014	0.007	0.005	-0.006
		TEMP	-1.691	-0.032	-0.470	0.128	-0.117	-0.003	-0.151	0.085
		SEIS	1.895	0.871	0.309	0.277	0.119	0.030	0.166	0.037
		HYDR	0.318	0.014	0.091	0.016	0.010	0.003	0.011	0.003
30 Pool Girder @ Fuel Pool	123067	OTHR	0.292	-0.040	-0.373	-0.019	-0.061	-0.010	-0.071	-0.038
		TEMP	-2.405	-6.001	-1.842	0.639	0.439	-0.117	-0.150	0.470
		SEIS	0.766	2.994	1.977	0.106	0.097	0.102	0.127	0.170
		HYDR	0.124	0.755	0.287	0.021	0.020	0.008	0.017	0.021
	123167	OTHR	0.054	-0.040	-0.424	0.007	-0.031	0.027	-0.064	0.001
		TEMP	-2.204	-2.669	-2.246	0.268	-0.449	-0.228	-0.011	0.180
		SEIS	0.932	0.809	1.827	0.065	0.104	0.067	0.074	0.028
		HYDR	0.336	0.219	0.315	0.014	0.006	0.005	0.008	0.003
31 MS Tunnel Wall and Slab	150122	OTHR	0.016	-0.187	0.341	0.022	0.085	0.015	-0.008	-0.058
		TEMP	0.224	-0.515	1.901	1.053	3.140	-0.007	-0.584	0.364
		SEIS	0.043	0.340	0.351	0.069	0.221	0.044	0.020	0.189
		HYDR	0.013	0.039	0.004	0.006	0.024	0.004	0.002	0.014
	96611	OTHR	-0.038	0.587	-0.035	0.059	-0.079	-0.053	-0.071	0.018
		TEMP	-0.447	4.103	-0.332	-1.287	-7.109	-0.423	0.426	0.209
		SEIS	0.034	0.440	0.046	0.183	0.626	0.129	0.128	0.071
		HYDR	0.007	0.053	0.008	0.031	0.072	0.013	0.011	0.006
	98614	OTHR	-0.019	-0.246	-0.018	-0.132	-0.854	-0.114	-0.011	0.046
		TEMP	-0.187	1.989	-0.145	-0.861	-10.477	-0.011	0.470	0.303
		SEIS	0.049	0.404	0.040	0.188	0.962	0.293	0.087	0.053
		HYDR	0.004	0.081	0.005	0.004	0.040	0.006	0.001	0.007
32 IC/PCCS Pool Wall in NS Dir.	125051	OTHR	0.114	0.016	0.234	-0.029	-0.007	0.000	-0.022	0.009
		TEMP	-0.257	-0.976	-0.150	-0.013	-0.016	-0.001	-0.024	-0.015
		SEIS	0.163	1.653	1.292	0.010	0.076	0.004	0.016	0.059
		HYDR	0.011	0.066	0.042	0.002	0.001	0.000	0.002	0.001
	125151	OTHR	0.184	-0.043	0.179	-0.038	-0.011	-0.001	-0.034	0.001
		TEMP	-0.404	-0.680	0.529	0.018	0.055	0.012	-0.030	-0.051
		SEIS	0.200	0.661	1.067	0.003	0.014	0.012	0.022	0.013
		HYDR	0.027	0.037	0.047	0.003	0.001	0.000	0.003	0.000
	125055	OTHR	0.172	-0.068	-0.087	0.010	0.031	0.002	0.015	0.024
		TEMP	-0.601	0.281	0.050	0.008	0.023	0.001	0.007	0.002
		SEIS	0.266	0.203	0.532	0.033	0.140	0.006	0.051	0.096
		HYDR	0.032	0.031	0.064	0.001	0.001	0.000	0.001	0.000
	125155	OTHR	0.311	-0.003	-0.068	0.001	-0.016	-0.001	-0.009	0.013
		TEMP	-1.201	-0.035	0.047	0.008	0.037	-0.005	-0.061	0.002
		SEIS	0.766	0.139	0.461	0.019	0.042	0.009	0.051	0.058
		HYDR	0.052	0.012	0.069	0.001	0.000	0.000	0.001	0.001

OTHR: Loads other than thermal, seismic and hydrodynamic loads

TEMP: Thermal loads

SEIS: Seismic loads

HYDR: Hydrodynamic loads

SI to U.S. Customary units conversion (SI units are the controlling units and U.S. Customary units are for reference only):

1 MN/m = 6.852x10⁴ lbf/ft, 1 MNm/m = 2.248x10⁵ lbf-ft/ft



Table 6.3.3-5 Combined Forces and Moments: LOCA + SSE: 72-hr. after: Winter: Load ID = 7441 (Site-Specific Seismic Load Combination RB-9b)

	Element ID		Nx (MN/m)	Ny (MN/m)	Nxy (MN/m)	Mx (MNm/m)	My (MNm/m)	Mxy (MNm/m)	Qx (MN/m)	Qy (MN/m)
18 Wall Below RCCV Bottom	6	OTHR	-1.459	-6.276	-0.223	-0.012	-0.366	-0.005	0.001	-0.005
		TEMP	0.745	-0.977	-0.895	0.238	1.920	-0.053	0.044	0.293
		SEIS	2.942	7.596	0.819	0.455	2.879	0.060	0.114	1.022
		HYDR	0.564	1.225	0.276	0.162	0.924	0.002	0.008	0.323
	13	OTHR	-1.372	-4.789	0.011	-0.318	-1.598	0.006	-0.005	-0.417
		TEMP	-0.174	-4.065	-0.782	0.604	3.357	-0.002	0.023	0.785
		SEIS	2.990	6.667	0.680	0.657	3.767	0.017	0.025	1.312
		HYDR	0.446	1.240	0.285	0.124	0.725	0.003	0.006	0.250
	24	OTHR	-1.209	-5.232	-0.159	-0.360	-2.171	-0.001	0.003	-0.735
		TEMP	0.101	-3.765	0.212	0.594	3.314	-0.007	-0.003	0.779
		SEIS	2.106	7.069	1.196	0.659	3.721	0.015	0.022	1.154
		HYDR	0.491	1.370	0.273	0.092	0.573	0.003	0.005	0.203
19 Wall Below RCCV Mid-Height	806	OTHR	-1.110	-5.086	-0.192	0.010	0.050	-0.021	-0.013	-0.074
		TEMP	1.907	-2.149	0.225	0.307	1.688	0.090	-0.068	-0.082
		SEIS	2.715	7.082	1.180	0.103	0.122	0.103	0.064	0.143
		HYDR	0.151	1.212	0.367	0.012	0.070	0.018	0.002	0.020
	813	OTHR	-1.511	-4.728	0.153	-0.017	0.125	-0.006	0.002	-0.040
		TEMP	1.360	-3.986	-0.566	0.221	1.702	-0.034	0.006	0.602
		SEIS	2.309	6.799	0.796	0.203	0.487	0.049	0.027	0.250
		HYDR	0.116	1.258	0.385	0.017	0.068	0.007	0.002	0.059
	824	OTHR	-1.789	-5.114	-0.055	0.106	0.407	0.009	-0.001	0.095
		TEMP	1.151	-3.732	0.198	0.224	1.729	0.027	0.015	0.502
		SEIS	2.360	7.372	1.689	0.244	0.499	0.027	0.013	0.267
		HYDR	0.127	1.390	0.359	0.009	0.073	0.009	0.001	0.038
20 Wall Below RCCV Top	1606	OTHR	-0.166	-4.464	-0.065	-0.178	-1.038	0.024	0.005	0.223
		TEMP	15.858	-3.114	0.381	-0.839	-4.009	0.124	0.101	3.042
		SEIS	2.278	6.409	2.761	0.223	1.075	0.123	0.028	0.360
		HYDR	0.485	1.233	0.351	0.259	1.447	0.006	0.005	0.427
	1613	OTHR	-0.359	-4.640	0.249	-0.204	-1.042	-0.003	-0.003	0.243
		TEMP	15.713	-4.649	-0.420	-1.005	-5.538	-0.011	-0.016	3.612
		SEIS	1.605	6.417	1.899	0.240	1.485	0.033	0.018	0.592
		HYDR	0.476	1.260	0.360	0.256	1.476	0.003	0.006	0.454
	1624	OTHR	0.030	-4.654	-0.010	-0.239	-1.464	0.006	-0.007	0.420
		TEMP	16.688	-4.842	-0.107	-1.115	-5.549	0.001	-0.106	3.698
		SEIS	1.940	6.999	2.725	0.198	1.333	0.043	0.033	0.536
		HYDR	0.524	1.371	0.354	0.254	1.436	0.003	0.008	0.449

OTHR: Loads other than thermal, seismic and hydrodynamic loads

TEMP: Thermal loads

SEIS: Seismic loads

HYDR: Hydrodynamic loads

SI to U.S. Customary units conversion (SI units are the controlling units and U.S. Customary units are for reference only):

1 MN/m = 6.852x10⁴ lbf/ft

1 MNm/m = 2.248x10⁵ lbf-ft/ft



Table 6.3.3-5 Combined Forces and Moments: LOCA + SSE: 72-hr. after: Winter: Load ID = 7441 (Site-Specific Seismic Load Combination RB-9b) (Continued)

	Element ID		Nx (MN/m)	Ny (MN/m)	Nxy (MN/m)	Mx (MNm/m)	My (MNm/m)	Mxy (MNm/m)	Qx (MN/m)	Qy (MN/m)
21 Exterior Wall @ EL-11.50 ~10.50m	20011	OTHR	-1.805	-3.402	-0.714	0.158	0.865	0.016	0.037	0.280
		TEMP	3.314	4.817	0.922	0.447	1.837	0.052	-0.225	0.576
		SEIS	2.212	3.459	2.195	0.719	2.803	0.032	0.055	1.107
		HYDR	0.099	0.152	0.412	0.204	0.828	0.007	0.021	0.305
	20023	OTHR	-1.160	-1.474	-0.591	-0.013	-0.242	0.012	-0.056	-0.139
		TEMP	-1.453	-1.169	1.549	1.890	4.020	0.180	0.322	0.683
		SEIS	1.327	1.953	0.794	0.532	0.597	0.101	0.629	0.404
		HYDR	0.011	0.336	0.082	0.053	0.078	0.008	0.064	0.048
	30010	OTHR	-1.196	-2.341	-0.172	-0.212	-1.176	0.010	0.001	0.872
		TEMP	0.688	3.733	-0.258	1.289	4.763	-0.022	-0.031	-0.865
		SEIS	3.058	1.953	1.026	0.436	2.379	0.029	0.027	0.869
		HYDR	0.304	0.132	0.184	0.100	0.526	0.002	0.004	0.133
	30020	OTHR	-0.963	-1.641	-0.229	-0.543	-0.782	0.019	-0.151	0.330
		TEMP	-0.058	-1.477	-0.392	0.021	1.209	0.144	-0.026	-0.282
		SEIS	0.847	1.721	1.415	0.490	0.912	0.160	0.406	0.430
		HYDR	0.024	0.444	0.117	0.021	0.092	0.004	0.033	0.028
	40001	OTHR	-0.760	-1.807	0.367	-0.327	-1.086	-0.198	0.069	0.628
		TEMP	-0.090	-1.141	0.056	0.039	1.330	-0.097	0.105	-0.322
		SEIS	0.790	1.806	1.368	0.537	1.002	0.216	0.330	0.403
		HYDR	0.024	0.458	0.102	0.034	0.083	0.005	0.034	0.022
	40011	OTHR	-1.371	-3.050	-0.027	-0.253	-1.527	-0.001	0.005	1.546
		TEMP	1.295	3.630	0.051	1.243	4.654	0.011	0.015	-0.844
		SEIS	1.584	2.452	1.304	0.425	2.280	0.016	0.021	0.762
		HYDR	0.232	0.250	0.214	0.069	0.354	0.003	0.006	0.085
22 Exterior Wall @ EL4.65 ~6.60m	22011	OTHR	0.178	-2.796	0.636	-0.005	0.104	0.012	-0.025	0.147
		TEMP	5.080	4.474	-0.209	-0.175	-0.228	0.067	0.045	0.074
		SEIS	1.226	5.546	4.092	0.153	0.818	0.090	0.050	0.715
		HYDR	0.173	0.555	0.436	0.009	0.057	0.014	0.002	0.115
	22023	OTHR	-0.060	-1.627	-0.051	0.070	0.037	-0.071	0.046	0.010
		TEMP	2.211	-3.114	-2.141	0.528	0.492	-0.052	0.386	0.393
		SEIS	0.750	5.668	3.527	0.299	0.222	0.141	0.357	0.148
		HYDR	0.037	0.295	0.213	0.080	0.023	0.019	-0.022	0.008
	32010	OTHR	0.125	-1.926	0.034	-0.019	0.005	0.006	0.000	-0.086
		TEMP	16.739	7.724	-0.075	-2.893	-3.003	-0.001	-0.014	0.022
		SEIS	1.206	3.569	3.077	0.057	0.356	0.022	0.004	0.219
		HYDR	0.201	0.217	0.231	0.014	0.033	0.003	0.001	0.076
	32020	OTHR	-0.004	-1.883	0.207	-0.013	-0.034	-0.047	0.001	0.025
		TEMP	0.653	4.869	2.518	0.104	-1.860	-0.395	1.226	0.199
		SEIS	0.525	6.282	2.371	0.441	0.184	0.173	0.243	0.069
		HYDR	0.023	0.275	0.154	0.054	0.005	0.010	0.040	0.004
	42001	OTHR	-0.007	-1.928	0.099	0.009	-0.065	0.058	-0.003	0.048
		TEMP	2.720	3.801	2.644	0.130	-1.563	-0.051	-0.998	-0.239
		SEIS	0.379	6.366	2.517	0.289	0.162	0.239	0.354	0.049
		HYDR	0.039	0.291	0.171	0.069	0.005	0.006	0.028	0.002
	42011	OTHR	-0.172	-2.235	-0.036	-0.039	-0.095	-0.004	0.004	-0.056
		TEMP	14.110	5.515	0.234	-3.164	-3.046	0.073	0.090	0.169
		SEIS	1.202	3.902	3.709	0.069	0.408	0.038	0.048	0.184
		HYDR	0.134	0.389	0.271	0.027	0.032	0.007	0.004	0.077

OTHR: Loads other than thermal, seismic and hydrodynamic loads

TEMP: Thermal loads

SEIS: Seismic loads

HYDR: Hydrodynamic loads

SI to U.S. Customary units conversion (SI units are the controlling units and U.S. Customary units are for reference only):

1 MN/m = 6.852x10⁴ lbf/ft

1 MNm/m = 2.248x10⁵ lbf-ft/ft



Table 6.3.3-5 Combined Forces and Moments: LOCA + SSE: 72-hr. after: Winter: Load ID = 7441 (Site-Specific Seismic Load Combination RB-9b) (Continued)

	Element ID		Nx (MN/m)	Ny (MN/m)	Nxy (MN/m)	Mx (MNm/m)	My (MNm/m)	Mxy (MNm/m)	Qx (MN/m)	Qy (MN/m)
23 Exterior Wall @ EL.22.50 ~24.60m	24211	OTHR	0.226	-1.528	0.079	-0.012	-0.136	0.013	0.004	-0.237
		TEMP	6.073	5.669	-0.239	0.176	0.982	0.008	-0.147	1.336
		SEIS	0.931	4.603	3.707	0.152	0.641	0.042	0.007	0.711
		HYDR	0.102	0.359	0.211	0.022	0.100	0.011	0.002	0.109
	24224	OTHR	-0.023	-1.406	0.156	0.025	-0.013	-0.017	-0.037	-0.021
		TEMP	1.011	5.349	-3.664	1.966	0.071	-0.637	-1.563	-0.323
		SEIS	0.511	8.980	3.791	0.769	1.137	0.261	0.367	1.272
		HYDR	0.017	0.354	0.169	0.068	0.046	0.018	0.034	0.049
	34210	OTHR	0.440	-0.801	0.073	0.005	0.103	0.000	0.002	0.042
		TEMP	21.813	5.545	-0.581	-2.903	-2.819	0.035	-0.002	-0.128
		SEIS	1.058	1.986	3.456	0.103	0.608	0.012	0.025	0.194
	34220	HYDR	0.147	0.074	0.125	0.010	0.055	0.006	0.001	0.030
		OTHR	0.061	-1.255	-0.002	0.046	0.014	0.002	0.032	-0.002
		TEMP	2.794	5.432	4.414	2.629	-1.178	-0.711	2.571	0.094
		SEIS	0.159	3.297	2.210	0.111	0.114	0.027	0.079	0.025
	44201	HYDR	0.020	0.170	0.072	0.025	0.010	0.012	0.016	0.005
		OTHR	0.024	-1.326	-0.064	0.050	0.018	0.002	-0.032	-0.007
		TEMP	1.793	6.586	0.562	2.230	-1.491	0.539	-2.967	0.044
		SEIS	0.167	3.795	2.479	0.068	0.041	0.040	0.109	0.024
	24 Basemat @ Wall Below RCCV	90140	HYDR	0.018	0.206	0.118	0.023	0.004	0.003	0.017
OTHR			-3.147	-2.640	0.202	-0.982	-0.349	1.403	-1.887	1.660
TEMP			0.838	1.691	1.751	-0.171	-1.046	-1.095	-1.135	0.139
SEIS			2.801	1.113	1.986	3.720	2.589	3.423	2.095	2.337
90182		HYDR	0.384	0.272	0.318	0.741	0.524	0.189	0.522	0.533
		OTHR	-2.369	-2.527	-0.049	0.166	-0.817	-0.005	0.044	0.431
		TEMP	1.908	0.687	0.488	-0.873	-5.527	0.260	-0.110	3.825
		SEIS	2.544	0.415	1.472	1.264	3.140	0.509	0.312	2.146
90111		HYDR	0.703	0.135	0.141	0.425	0.324	0.130	0.153	0.588
		OTHR	-3.909	-2.406	-0.028	-1.440	0.138	-0.188	0.132	0.116
		TEMP	0.733	2.908	-0.011	-5.322	-1.147	0.107	3.687	0.151
		SEIS	0.479	1.371	1.951	3.034	1.044	0.680	1.765	0.565
		HYDR	0.099	0.619	0.041	0.248	0.342	0.104	0.550	0.150

OTHR: Loads other than thermal, seismic and hydrodynamic loads

TEMP: Thermal loads

SEIS: Seismic loads

HYDR: Hydrodynamic loads

SI to U.S. Customary units conversion (SI units are the controlling units and U.S. Customary units are for reference only):

1 MN/m = 6.852x10⁴ lbf/ft

1 MNm/m = 2.248x10⁵ lbf-ft/ft

**Table 6.3.3-5 Combined Forces and Moments: LOCA + SSE: 72-hr. after: Winter: Load ID = 7441 (Site-Specific Seismic Load Combination RB-9b) (Continued)**

Location	Element ID		Nx (MN/m)	Ny (MN/m)	Nxy (MN/m)	Mx (MNm/m)	My (MNm/m)	Mxy (MNm/m)	Qx (MN/m)	Qy (MN/m)
25 Slab EL4.65m @ RCCV	93140	OTHR	-0.338	0.086	0.260	0.104	0.116	-0.095	0.130	-0.110
		TEMP	-0.383	3.018	5.804	-0.739	-0.564	0.413	-0.192	0.163
		SEIS	1.713	0.333	0.267	0.269	0.210	0.146	0.126	0.111
		HYDR	0.141	0.153	0.201	0.027	0.019	0.026	0.008	0.009
	93182	OTHR	0.178	-0.133	0.020	0.009	0.081	0.007	-0.004	-0.051
		TEMP	6.161	-5.154	-1.518	-0.481	-2.508	-0.114	0.105	1.903
		SEIS	0.313	0.148	0.131	0.128	0.637	0.030	0.030	0.587
		HYDR	0.232	0.069	0.068	0.019	0.031	0.003	0.004	0.080
	93111	OTHR	-0.173	0.295	-0.024	0.030	-0.003	-0.001	-0.008	-0.005
		TEMP	-4.494	6.820	-0.448	-2.369	-0.414	-0.066	1.594	0.001
		SEIS	0.185	0.254	0.154	0.537	0.097	0.022	0.434	0.005
		HYDR	0.073	0.256	0.054	0.010	0.016	0.001	0.051	0.002
26 Slab EL17.5m @ RCCV	96144	OTHR	0.012	0.551	0.669	0.131	0.133	-0.104	0.136	-0.116
		TEMP	0.733	5.839	8.138	-0.232	-0.178	0.174	-0.043	0.066
		SEIS	0.611	0.374	0.224	0.221	0.196	0.136	0.109	0.086
		HYDR	0.042	0.018	0.169	0.049	0.040	0.024	0.009	0.010
	96186	OTHR	0.866	-0.359	-0.094	0.009	0.079	0.002	-0.005	-0.103
		TEMP	9.999	-4.559	-2.165	-0.150	-0.675	-0.057	0.023	0.638
		SEIS	0.532	0.188	0.210	0.115	0.599	0.026	0.031	0.481
		HYDR	0.127	0.072	0.088	0.025	0.116	0.004	0.006	0.093
	96113	OTHR	-0.447	1.387	-0.140	0.168	0.057	0.000	0.002	0.013
		TEMP	-9.165	5.149	-1.811	-4.378	-2.755	-0.237	1.010	-0.100
		SEIS	0.090	1.066	0.667	1.234	0.140	0.053	1.033	0.124
		HYDR	0.043	0.239	0.139	0.179	0.044	0.006	0.138	0.015
27 Slab EL27.0m @ RCCV	98472	OTHR	0.541	0.521	-0.068	0.159	0.239	-0.092	0.321	-0.342
		TEMP	-3.645	-3.148	5.906	-1.729	-1.315	-0.297	0.534	-0.685
		SEIS	0.794	0.877	0.373	0.464	0.714	0.577	0.448	0.527
		HYDR	0.075	0.036	0.103	0.045	0.059	0.029	0.035	0.038
	98514	OTHR	0.312	0.396	0.031	-0.011	-0.282	0.003	-0.010	-0.043
		TEMP	-2.902	-2.765	-1.440	-1.895	-1.503	-0.079	0.078	-0.381
		SEIS	0.669	0.096	0.371	0.189	1.155	0.076	0.047	0.772
		HYDR	0.121	0.054	0.118	0.020	0.094	0.001	0.001	0.074
	98424	OTHR	-0.248	1.315	-0.050	0.415	0.227	-0.104	-0.703	-0.054
		TEMP	-8.825	-1.775	-2.345	3.485	0.429	0.374	-5.774	-0.156
		SEIS	1.057	1.196	3.487	2.644	0.649	0.155	1.814	0.149
		HYDR	0.033	0.106	0.068	0.172	0.073	0.010	0.118	0.007

OTHR: Loads other than thermal, seismic and hydrodynamic loads

TEMP: Thermal loads

SEIS: Seismic loads

HYDR: Hydrodynamic loads

SI to U.S. Customary units conversion (SI units are the controlling units and U.S. Customary units are for reference only):

1 MN/m = 6.852x10⁴ lbf/ft1 MNm/m = 2.248x10⁵ lbf-ft/ft



Table 6.3.3-5 Combined Forces and Moments: LOCA + SSE: 72-hr. after: Winter: Load ID = 7441 (Site-Specific Seismic Load Combination RB-9b) (Continued)

Location	Element ID		Nx (MN/m)	Ny (MN/m)	Nxy (MN/m)	Mx (MNm/m)	My (MNm/m)	Mxy (MNm/m)	Qx (MN/m)	Qy (MN/m)
28 Pool Girder @ Storage Pool	123054	OTHR	0.254	0.062	0.883	0.063	0.032	-0.096	-0.040	-0.052
		TEMP	3.583	1.298	2.382	3.613	2.453	-0.343	0.113	0.317
		SEIS	0.569	3.326	1.105	0.205	0.094	0.091	0.049	0.123
		HYDR	0.085	0.112	0.096	0.007	0.006	0.004	0.008	0.009
	123154	OTHR	0.469	-0.118	0.803	0.073	0.035	-0.096	-0.061	0.024
		TEMP	3.638	3.575	-2.911	3.372	1.303	-0.374	-0.255	0.413
		SEIS	1.837	0.841	1.008	0.167	0.070	0.158	0.061	0.020
		HYDR	0.157	0.021	0.091	0.010	0.007	0.011	0.004	0.001
29 Pool Girder @ Cavity	123062	OTHR	0.359	-0.748	-0.884	0.004	0.130	0.007	0.034	0.079
		TEMP	0.505	0.115	-1.385	3.836	3.893	0.008	0.034	0.188
		SEIS	0.576	1.124	0.540	0.154	0.283	0.046	0.080	0.160
		HYDR	0.088	0.010	0.070	0.006	0.008	0.003	0.003	0.002
	123162	OTHR	1.266	-0.294	-0.641	0.030	-0.001	0.004	-0.012	-0.011
		TEMP	1.929	0.409	-1.840	3.803	2.820	0.092	-0.288	0.644
		SEIS	1.895	0.871	0.309	0.277	0.119	0.030	0.166	0.037
		HYDR	0.233	0.010	0.066	0.012	0.008	0.002	0.008	0.002
30 Pool Girder @ Fuel Pool	123067	OTHR	0.253	0.356	-0.750	-0.024	-0.063	0.006	-0.059	-0.044
		TEMP	-2.101	-7.271	-3.005	3.592	3.540	-0.636	0.317	0.815
		SEIS	0.766	2.994	1.977	0.106	0.097	0.102	0.127	0.170
		HYDR	0.090	0.556	0.209	0.015	0.014	0.006	0.012	0.015
	123167	OTHR	-0.044	0.041	-0.769	0.005	-0.035	0.028	-0.062	0.004
		TEMP	-0.679	-2.776	-3.132	2.749	1.834	-0.242	-0.176	0.616
		SEIS	0.932	0.809	1.827	0.065	0.104	0.067	0.074	0.028
		HYDR	0.249	0.161	0.229	0.010	0.004	0.004	0.006	0.002
31 MS Tunnel Wall and Slab	150122	OTHR	0.024	-0.229	0.352	0.021	0.090	0.015	-0.007	-0.062
		TEMP	0.316	-0.711	1.797	0.940	3.101	0.011	-0.551	0.426
		SEIS	0.043	0.340	0.351	0.069	0.221	0.044	0.020	0.189
		HYDR	0.009	0.029	0.003	0.004	0.018	0.003	0.001	0.010
	96611	OTHR	-0.044	0.652	-0.040	0.056	-0.087	-0.054	-0.070	0.018
		TEMP	-0.557	4.662	-0.414	-1.254	-7.116	-0.406	0.420	0.206
		SEIS	0.034	0.440	0.046	0.183	0.626	0.129	0.128	0.071
		HYDR	0.005	0.039	0.006	0.023	0.054	0.009	0.008	0.004
	98614	OTHR	-0.019	-0.264	-0.018	-0.160	-0.915	-0.124	-0.002	0.049
		TEMP	-0.043	0.725	-0.043	-0.850	-9.922	-0.018	0.459	0.307
		SEIS	0.049	0.404	0.040	0.188	0.962	0.293	0.087	0.053
		HYDR	0.003	0.061	0.003	0.003	0.030	0.004	0.001	0.005
32 IC/PCCS Pool Wall in NS Dir.	125051	OTHR	0.151	0.243	0.465	-0.034	0.004	0.001	-0.026	0.018
		TEMP	-2.425	-2.173	-0.782	0.093	0.096	-0.014	0.023	0.036
		SEIS	0.163	1.653	1.292	0.010	0.076	0.004	0.016	0.059
		HYDR	0.008	0.048	0.031	0.001	0.001	0.000	0.002	0.001
	125151	OTHR	0.235	0.020	0.367	-0.043	-0.010	0.000	-0.042	0.002
		TEMP	-2.083	-1.572	1.896	0.131	0.140	0.029	0.019	-0.082
		SEIS	0.200	0.661	1.067	0.003	0.014	0.012	0.022	0.013
		HYDR	0.020	0.027	0.035	0.002	0.001	0.000	0.002	0.000
	125055	OTHR	0.188	-0.090	-0.086	0.016	0.058	0.002	0.024	0.041
		TEMP	-4.971	-0.309	0.162	0.019	0.097	0.004	-0.047	-0.011
		SEIS	0.266	0.203	0.532	0.033	0.140	0.006	0.051	0.096
		HYDR	0.023	0.022	0.047	0.000	0.000	0.000	0.000	0.000
	125155	OTHR	0.472	-0.022	-0.065	0.001	-0.024	-0.002	-0.020	0.024
		TEMP	-4.973	-0.680	0.046	0.014	0.094	-0.011	-0.133	0.027
		SEIS	0.766	0.139	0.461	0.019	0.042	0.009	0.051	0.058
		HYDR	0.039	0.008	0.050	0.000	0.000	0.000	0.001	0.000

OTHR: Loads other than thermal, seismic and hydrodynamic loads

TEMP: Thermal loads

SEIS: Seismic loads

HYDR: Hydrodynamic loads

SI to U.S. Customary units conversion (SI units are the controlling units and U.S. Customary units are for reference only):

1 MN/m = 6.852x10⁴ lbf/ft, 1 MNm/m = 2.248x10⁵ lbf-ft/ft



Table 6.4.1-1 Material Constants for Stress Calculations

Material	Property	Value	
Concrete	Compressive strength, f_c'	Basemat	27.6 MPa
		Top Slab	41.1 MPa
		Others	34.5 MPa
	Young's modulus	Basemat	2.49×10^4 MPa
		Top Slab	3.04×10^4 MPa
		Others	2.78×10^4 MPa
Poisson's ratio	0.17		
Reinforcement	Yield stress, f_y	413.6 MPa	
	Young's modulus	2.00×10^5 MPa	

Table 6.4.1-2 Allowable Stress of Concrete for Membrane Plus Bending

Load Category	Load Condition	Allowable Compressive Stress (MPa)		
Factored	Primary	Basemat	20.7	$(0.75 f_c')$
		Top Slab	31.1	
		Others	25.9	
	Primary plus secondary	Basemat	23.5	$(0.85 f_c')$
		Top Slab	35.2	
		Others	29.3	
Service	Primary	Basemat	12.4	$(0.45 f_c')$
		Top Slab	18.6	
		Others	15.5	
	Primary plus secondary	Basemat	16.6	$(0.60 f_c')$
		Top Slab	24.8	
		Others	20.7	



Table 6.4.1-3 Allowable Stress of Reinforcement for Membrane Plus Bending

	Load Category	Load Condition	Allowable Stress (MPa)
Tension	Factored	Primary	372.2 (0.90 f_y)
		Primary plus secondary	
	Service	SIT	310.2 (0.75 f_y)
		Primary plus secondary	273.0 (0.66 f_y)
	Other	206.8 (0.50 f_y)	
Compression	Factored	Primary	372.2 (0.90 f_y)
		Primary plus secondary	
	Service	SIT	273.0 (0.66 f_y)
		Primary plus secondary	
	Other	206.8 (0.50 f_y)	

Table 6.4.1-4 Allowable Stress of Concrete for Membrane Compressive Forces

Load Category	Load Condition	Allowable Compressive Stress (MPa)		
Factored	Primary	Basemat	16.6	(0.60 f_c')
		Top Slab	24.8	
		Others	20.7	
	Primary plus secondary	Basemat	20.7	(0.75 f_c')
		Top Slab	31.0	
		Others	25.9	
Service	Primary	Basemat	8.3	(0.30 f_c')
		Top Slab	12.4	
		Others	10.4	
	Primary plus secondary	Basemat	12.4	(0.45 f_c')
		Top Slab	18.6	
		Others	15.5	



Table 7.3.1.1-1 Sectional Thicknesses and Rebar Ratios of RB Used in the Evaluation

Location	Element ID	Thickness (m)	Primary Reinforcement				Shear Tie			
			Position	Direction 1 ¹		Direction 2 ¹		Arrangement	Ratio (%)	
				Arrangement ²	Ratio (%)	Arrangement ²	Ratio (%)			
18 Wall Below RCCV Bottom	6	2.0	Inside	2-#18@300	0.860	3-#18@0.9°	1.297	#9@0.9°x300	0.721	
	13		Outside	3-#18@300	1.290	3-#18@0.9° +1-#18@0.9°	1.729			
19 Wall Below RCCV Mid-Height	806	2.0	Inside	2-#18@300	0.860	3-#18@0.9°	1.297	#9@1.2°x600	0.270	
	813		Outside	3-#18@300	1.290	3-#18@0.9°	1.297			
20 Wall Below RCCV Top	1606	2.0	Inside	2-#18@300	0.860	3-#18@0.9°	1.297	#9@1.2°x300	0.540	
	1613		Outside	3-#18@300	1.290	3-#18@0.9° +1-#18@1.8°	1.513			
21 Exterior Wall @ EL-11.50 to -10.50m	20011	2.0	Inside	4-#11@200 +1-#11@400	1.132	5-#11@200 (+1-#11@200)	1.510	#7@400x200	0.484	
			Outside	4-#11@200 +1-#11@400	1.132	5-#11@200 (+2-#11@200)	1.761			
	20023	2.0	Inside	4-#11@200 +1-#11@400	1.132	5-#11@200 (+1-#11@200)	1.510	#7@400x200	0.484	
			Outside	4-#11@200 +1-#11@400	1.132	5-#11@200	1.258			
	30010	2.0	Inside	1-#11@100 +3-#11@200	1.258	2-#11@100 +2-#11@200	1.510	#6@200x200	0.710	
			Outside	2-#11@100 +2-#11@200	1.510	3-#11@100 +1-#11@200	1.761			
	40001	2.0	Inside	1-#11@100 +3-#11@200	1.258	2-#11@100 +2-#11@200	1.510	#6@200x200	0.710	
			Outside	2-#11@100 +2-#11@200	1.510	2-#11@100 +2-#11@200	1.510			
	22 Exterior Wall @ EL4.65 to 6.60m	22011	1.5	Inside	3-#11@200 +1-#11@400	1.174	4-#11@200 (+1-#11@200)	1.677	#7@400x200	0.484
				Outside	3-#11@200 +1-#11@400	1.174	4-#11@200 (+1-#11@200)	1.677		
		22023	1.5	Inside	3-#11@200 +1-#11@400	1.174	4-#11@200	1.342	#7@400x200	0.484
				Outside	3-#11@200 +1-#11@400	1.174	4-#11@200	1.342		
32010		1.5	Inside	3-#11@200	1.006	3-#11@200	1.006	#6@400x400	0.177	
			Outside	3-#11@200 (+2-#11@200)	1.677	3-#11@200 (+2-#11@200)	1.677			
32020		1.5	Inside	3-#11@200	1.006	3-#11@200	1.006	#6@400x400	0.177	
			Outside	3-#11@200	1.006	3-#11@200	1.006			
42001		1.5	Inside	3-#11@200	1.006	3-#11@200	1.006	#7@400x400	0.242	
			Outside	4-#11@200	1.342	4-#11@200	1.342			



Table 7.3.1.1-1 Sectional Thicknesses and Rebar Ratios of RB Used in the Evaluation (Continued)

Location	Element ID	Thickness (m)	Primary Reinforcement						Shear Tie	
			Position	Direction 1 ^{*1}		Direction 2 ^{*1}		Arrangement	Ratio (%)	
				Arrangement ^{**2}	Ratio (%)	Arrangement ^{**2}	Ratio (%)			
22 Exterior Wall @ EL4.65 to 6.60m	42011	1.5	Inside	3-#11@200	1.006	3-#11@200	1.006	#7@400x400	0.242	
			Outside	4-#11@200 (+1-#11@200)	1.677	4-#11@200 (+1-#11@200)	1.677			
23 Exterior Wall @ EL22.50 to 24.60m	24211	1.5	Inside	3-#11@200 +1-#11@400	1.174	4-#11@200 (+1-#11@200)	1.677	#7@200x200	0.968	
			Outside	3-#11@200 +1-#11@400	1.174	4-#11@200	1.342			
	24224	1.5	Inside	3-#11@200 +1-#11@400	1.174	4-#11@200 (+1-#11@200)	1.677	#7@200x200	0.968	
			Outside	3-#11@200 +1-#11@400	1.174	4-#11@200 (+1-#11@200)	1.677			
	34210	1.5	Inside	3-#11@200	1.006	3-#11@200	1.006	#6@400x400	0.177	
			Outside	3-#11@200 (+2-#11@200)	1.677	3-#11@200 (+2-#11@200)	1.677			
	34220	1.5	Inside	3-#11@200	1.006	3-#11@200	1.006	#6@200x200	0.710	
			Outside	3-#11@200	1.006	3-#11@200	1.006			
	44201	1.5	Inside	3-#11@200	1.006	3-#11@200	1.006	#7@200x200	0.968	
			Outside	4-#11@200	1.342	4-#11@200	1.342			
	24 Basemat @ Wall Below RCCV	90140 90182 90111	4.0	Top	5-#11@0.9°	0.401	4-#11@200 +1-#11@400	0.566	#11@0.9x400	0.801
				Bottom	5-#11@200	0.629	5-#11@200	0.629		
25 Slab EL4.65m @ RCCV	93140 93182 93111	1.0	Top	2-#11@200	1.006	2-#11@200	1.006	#5@200x200	0.500	
			Bottom	2-#11@200	1.006	2-#11@200	1.006			
26 Slab EL17.5m @ RCCV	96144 96186	1.0	Top	2-#11@200	1.006	2-#11@200	1.006	#5@200x200	0.500	
			Bottom	2-#11@200	1.006	2-#11@200	1.006			
	96113	1.6	Top	2-#11@200	0.629	2-#11@200	0.629	#5@200x200	0.500	
			Bottom	3-#11@200	0.944	3-#11@200	0.944			

Note: Updated reinforcement arrangements from standard design are shown in red.



HITACHI

WG3-U71-ERD-S-0004 SH NO. 206
REV. 0 of 538

Table 7.3.1.1-1 Sectional Thicknesses and Rebar Ratios of RB Used in the Evaluation (Continued)

Location	Element ID	Thickness (m)	Primary Reinforcement				Shear Tie		
			Position	Direction 1 ^{*1}		Direction 2 ^{*1}		Arrangement	Ratio (%)
				Arrangement ^{*2}	Ratio (%)	Arrangement ^{*2}	Ratio (%)		
27 Slab EL27.0m @ RCCV	98472 98514	1.5	Top	3-#11@200 (+2-#11@200)	1.677	3-#11@200 (+2-#11@200)	1.677	#7@200x200	0.968
			Bottom	3-#11@200 (+3-#11@200)	2.013	3-#11@200 (+3-#11@200)	2.013		
	98424	2.4	Top	4-#11@200 (+2-#11@200)	1.258	4-#11@200 (+2-#11@200)	1.258	#7@200x200	0.968
			Bottom	4-#11@200 (+1-#11@200)	1.048	4-#11@200 (+1-#11@200)	1.048		
28 Pool Girder @ Storage Pool	123054 123154	1.6	Inside	3-#11@200	0.944	3-#11@200	0.944	#7@400x200	0.484
			Outside	3-#11@200 (+1-#11@200)	1.258	3-#11@200	0.944		
29 Pool Girder @ Well	123062 123162	1.6	Inside	3-#11@200	0.944	3-#11@200	0.944	#7@400x400	0.242
			Outside	3-#11@200	0.944	3-#11@200	0.944		
30 Pool Girder @ Buffer Pool	123067 123167	1.6	Inside	3-#11@200 (+1-#11@200)	1.258	3-#11@200 (+1-#11@200)	1.258	#7@400x200	0.484
			Outside	3-#11@200	0.944	3-#11@200	0.944		
31 MS Tunnel Wall and Slab	150122	1.3	Inside	2-#11@200	0.774	2-#11@200	0.774	#6@400x400	0.177
			Outside	2-#11@200 +1-#11@400	0.968	2-#11@200 +1-#11@400	0.968		
	96611	1.6	Top	2-#11@200	0.629	2-#11@200	0.629	#5@200x200	0.500
			Bottom	3-#11@200	0.944	3-#11@200	0.944		
	98614	2.4	Top	4-#11@200	0.839	4-#11@200	0.839	#5@200x200	0.500
			Bottom	3-#11@200	0.629	3-#11@200	0.629		
32 IC/PCCS Pool Wall in NS Dir.	125051 125151 125055 125155	1.0	Inside	1-#11@200 +1-#11@400	0.755	1-#11@200 +1-#11@400	0.755	#5@400x200	0.250
			Outside	2-#11@200	1.006	2-#11@200 (+1-#11@400)	1.258		

Note *1: Wall Below RCCV
Exterior Wall
Slab/MS Tunnel Slab
Pool Girder
MS Tunnel Wall
Basemat

Direction 1: Hoop
Direction 1: Horizontal
Direction 1: N-S
Direction 1: Horizontal
Direction 1: Horizontal
Direction 1: Top; Radial; Bottom; N-S

Direction 2: Vertical
Direction 2: Vertical
Direction 2: E-W
Direction 2: Vertical
Direction 2: Vertical
Direction 2: Top; Circumferential; Bottom; E-W

Note *2: Rebar in parenthesis indicates additional bars locally required.

SI to U.S. Customary units conversion (SI units are the controlling units and U.S. Customary units are for reference only):
1m=3.28ft



**Table 7.3.1.1-2 Rebar and Concrete Stresses of RB: 1.05D + 1.3L +1.3To + 1.3W: Winter:
Load ID = 4021 (Selected Load Combination RB-4)**

Location	Element ID	Concrete Stress (MPa)		Primary Reinforcement Stress (MPa)				Allowable
		Calculated	Allowable	Calculated				
				Direction 1'		Direction 2'		
				In/Top	Out/Bottom	In/Top	Out/Bottom	
18 Wall	6	-3.6	-29.3	2.6	3.4	-24.0	-21.2	372.2
Below RCCV	13	-4.0	-29.3	0.5	1.0	-27.0	-24.6	372.2
Bottom	24	-5.1	-29.3	3.2	3.1	-33.1	-22.9	372.2
19 Wall Below	806	-4.5	-29.3	2.7	3.3	-17.9	-27.7	372.2
Below RCCV	813	-5.2	-29.3	-0.7	0.7	-20.6	-31.7	372.2
Mid-Height	824	-6.1	-29.3	-1.1	-1.0	-21.3	-36.0	372.2
20 Wall	1606	-5.8	-29.3	16.8	18.3	-33.7	-12.9	372.2
Below RCCV	1613	-8.2	-29.3	13.9	17.0	-45.8	-8.9	372.2
Top	1624	-9.3	-29.3	18.3	23.3	-51.4	-11.3	372.2
21 Exterior Wall	20011	-1.6	-29.3	4.5	0.7	6.0	-7.5	372.2
@ EL-11.50	20023	-5.9	-29.3	14.7	-16.8	23.6	-20.7	372.2
~-10.50m	30010	-1.6	-29.3	0.0	-8.8	1.1	-1.4	372.2
	30020	-1.9	-29.3	-7.1	1.0	-4.5	-11.1	372.2
	40001	-1.7	-29.3	-4.0	-0.9	-6.0	-9.0	372.2
	40011	-1.1	-29.3	0.2	-4.0	3.1	-5.3	372.2
22 Exterior Wall	22011	-1.2	-29.3	31.4	26.7	12.2	6.8	372.2
@ EL4.65	22023	-5.0	-29.3	13.2	13.5	-13.0	-38.2	372.2
~6.60m	32010	-0.7	-29.3	25.0	90.5	-4.2	10.8	372.2
	32020	-3.9	-29.3	4.7	44.8	-7.6	51.1	372.2
	42001	-3.4	-29.3	7.8	32.7	-10.4	27.4	372.2
	42011	-2.6	-29.3	30.6	83.4	-12.1	13.0	372.2
23 Exterior Wall	24211	-1.9	-29.3	8.9	17.6	-4.9	8.4	372.2
@ EL22.50	24224	-2.4	-29.3	31.2	-0.4	9.2	9.5	372.2
~24.60m	34210	-3.3	-29.3	35.1	104.6	-6.0	43.5	372.2
	34220	-0.6	-29.3	44.6	-12.1	-9.1	33.0	372.2
	44201	-0.5	-29.3	53.1	33.9	6.8	71.8	372.2
24 Basemat	90140	-1.7	-23.5	-11.4	-3.2	1.6	0.0	372.2
@ Wall	90182	-2.4	-23.5	-12.5	-4.6	-0.9	8.4	372.2
Below RCCV	90111	-3.1	-23.5	-18.6	6.7	3.0	-1.0	372.2
25 Slab	93140	-7.0	-29.3	26.6	70.8	62.6	87.9	372.2
EL4.65m	93182	-11.1	-29.3	19.1	19.9	-48.7	41.1	372.2
@ RCCV	93111	-11.0	-29.3	-47.1	48.6	33.2	37.3	372.2
26 Slab	96144	-4.3	-29.3	69.4	83.6	90.8	97.9	372.2
EL17.5m	96186	-5.5	-29.3	30.0	58.6	-36.7	28.6	372.2
@ RCCV	96113	-11.1	-29.3	-46.8	76.6	-30.4	56.1	372.2
27 Slab	98472	-7.6	-29.3	58.2	68.0	60.9	52.9	372.2
EL27.0m	98514	-2.7	-29.3	-3.9	13.1	-11.2	-4.5	372.2
@ RCCV	98424	-6.7	-29.3	-15.9	-36.4	-30.0	-24.5	372.2

Note: Negative value means compression.

Note *:	Wall Below RCCV	Direction1: Hoop,	Direction2: Vertical
	Exterior Wall	Direction1: Horizontal,	Direction2: Vertical
	Slab/MS Tunnel Slab	Direction1: N-S,	Direction2: E-W
	Pool Girder	Direction1: Horizontal,	Direction2: Vertical
	MS Tunnel Wall	Direction1: Horizontal,	Direction2: Vertical
	Basemat	Direction1: Top; Radial, Bottom; N-S,	Direction2: Top; Circumferential, Bottom; E-W



**Table 7.3.1.1-2 Rebar and Concrete Stresses of RB: 1.05D + 1.3L + 1.3To + 1.3W: Winter:
Load ID = 4021 (Selected Load Combination RB-4) (Continued)**

Location	Element ID	Concrete Stress (MPa)		Primary Reinforcement Stress (MPa)				Allowable
		Calculated	Allowable	Calculated				
				Direction 1'		Direction 2'		
				In/Top	Out/Bottom	In/Top	Out/Bottom	
28 Pool Girder	123054	-8.7	-29.3	9.8	61.7	-43.0	-3.4	372.2
@ Storage Pool	123154	-3.4	-29.3	20.4	96.0	4.7	66.4	372.2
29 Pool Girder	123062	-1.9	-29.3	-13.2	-12.5	33.1	8.2	372.2
@ Cavity	123162	-2.7	-29.3	-19.2	-18.8	15.9	3.7	372.2
30 Pool Girder	123067	-5.7	-29.3	-14.1	-3.6	-33.9	-26.1	372.2
@ Fuel Pool	123167	-4.0	-29.3	-13.4	-7.4	-6.5	-17.7	372.2
31 MS Tunnel	150122	-13.6	-29.3	14.0	169.7	-22.9	220.5	372.2
Wall and Slab	96611	-8.6	-29.3	1.4	5.1	-21.1	194.3	372.2
	98614	-6.4	-29.3	2.8	2.6	-3.7	152.0	372.2
32 IC/PCCS	125051	-3.1	-29.3	21.4	15.7	3.4	-8.1	372.2
Pool Wall	125151	-1.6	-29.3	-4.0	-3.0	-9.0	-6.0	372.2
in NS Dir.	125055	-1.3	-29.3	-7.9	-8.3	11.2	-0.4	372.2
	125155	-2.2	-29.3	-14.7	-14.4	-1.1	1.6	372.2

Note: Negative value means compression.

Note *:	Wall Below RCCV	Direction1: Hoop,	Direction2: Vertical
	Exterior Wall	Direction1: Horizontal,	Direction2: Vertical
	Slab/MS Tunnel Slab	Direction1: N-S,	Direction2: E-W
	Pool Girder	Direction1: Horizontal,	Direction2: Vertical
	MS Tunnel Wall	Direction1: Horizontal,	Direction2: Vertical
	Basemat	Direction1: Top; Radial, Bottom; N-S,	Direction2: Top; Circumferential, Bottom; E-W



**Table 7.3.1.1-3 Rebar and Concrete Stresses of RB: 6-min. after LOCA (1.5Pa): Winter:
Load ID = 6241(Selected Load Combination RB-8a)**

Location	Element ID	Concrete Stress (MPa)		Primary Reinforcement Stress (MPa)					
		Calculated	Allowable	Calculated				Allowable	
				Direction 1'		Direction 2'			
In/Top	Out/Bottom	In/Top	Out/Bottom	In/Top	Out/Bottom	Out/Bottom			
18 Wall Below RCCV Bottom	6	-6.9	-29.3	8.0	20.8	-15.5	-38.1	372.2	
	13	-6.9	-29.3	-1.6	-2.0	-16.4	-39.3	372.2	
	24	-6.1	-29.3	2.5	2.5	-22.2	-37.3	372.2	
19 Wall Below Below RCCV Mid-Height	806	-5.6	-29.3	13.8	6.1	-17.9	-33.1	372.2	
	813	-6.3	-29.3	2.0	2.7	-21.8	-37.6	372.2	
	824	-6.9	-29.3	1.2	1.2	-22.0	-40.7	372.2	
20 Wall Below RCCV Top	1606	-15.9	-29.3	34.2	81.8	-63.3	41.3	372.2	
	1613	-17.0	-29.3	31.6	78.3	-73.0	44.6	372.2	
	1624	-16.6	-29.3	41.2	91.5	-81.1	45.0	372.2	
21 Exterior Wall @ EL-11.50 ~10.50m	20011	-5.3	-29.3	32.5	20.9	51.6	-16.6	372.2	
	20023	-4.9	-28.9	10.2	-13.6	15.9	-19.6	368.9	
	30010	-2.8	-29.3	5.9	-7.1	24.0	-9.7	372.2	
	30020	-2.2	-29.3	-5.6	2.9	-7.3	-13.2	372.2	
	40001	-2.1	-29.3	-3.5	1.0	-8.0	-12.0	372.2	
	40011	-2.3	-29.3	6.3	-4.5	9.6	-10.9	372.2	
22 Exterior Wall @ EL4.65 ~6.60m	22011	-2.6	-29.3	80.4	66.5	27.9	21.6	372.2	
	22023	-5.0	-29.3	44.0	11.3	-9.4	-25.2	372.2	
	32010	-0.7	-29.3	71.5	111.0	30.6	63.9	372.2	
	32020	-3.5	-29.3	9.2	40.8	-9.7	45.1	372.2	
	42001	-2.8	-29.3	10.9	31.1	-12.1	34.3	372.2	
	42011	-4.5	-29.3	35.5	91.4	-15.7	44.3	372.2	
23 Exterior Wall @ EL22.50 ~24.60m	24211	-0.8	-29.3	61.8	41.3	47.2	7.5	372.2	
	24224	-2.0	-29.3	27.0	13.1	4.3	18.7	372.2	
	34210	-0.4	-29.3	92.4	165.9	22.2	114.3	372.2	
	34220	-2.9	-29.3	39.8	-12.1	-16.7	33.2	372.2	
	44201	-0.6	-29.3	50.6	4.0	-16.7	39.9	372.2	
24 Basemat @ Wall Below RCCV	90140	-1.4	-23.5	-9.3	-8.1	1.6	-2.9	372.2	
	90182	-1.8	-23.5	-9.5	23.1	6.2	5.1	372.2	
	90111	-2.4	-23.5	-13.8	3.9	32.1	10.5	372.2	
25 Slab EL4.65m @ RCCV	93140	-8.7	-29.3	81.5	120.6	124.2	151.8	372.2	
	93182	-11.9	-29.3	60.7	72.5	-57.5	28.3	372.2	
	93111	-11.0	-29.3	-52.5	28.8	72.7	84.2	372.2	
26 Slab EL17.5m @ RCCV	96144	-9.9	-29.3	199.6	217.6	268.0	208.8	372.2	
	96186	-7.0	-29.3	114.4	130.8	-26.9	-23.7	372.2	
	96113	-13.6	-28.8	-87.9	28.6	83.6	115.1	368.2	
27 Slab EL27.0m @ RCCV	98472	-5.7	-29.1	66.3	53.0	71.1	51.0	370.3	
	98514	-2.6	-29.1	16.8	33.1	-6.5	18.8	370.3	
	98424	-5.2	-28.1	-18.6	-30.7	-13.6	-8.6	363.0	

Note: Negative value means compression.

Note *: Wall Below RCCV Direction1: Hoop, Direction2: Vertical
 Exterior Wall Direction1: Horizontal, Direction2: Vertical
 Slab/MS Tunnel Slab Direction1: N-S, Direction2: E-W
 Pool Girder Direction1: Horizontal, Direction2: Vertical
 MS Tunnel Wall Direction1: Horizontal, Direction2: Vertical
 Basemat Direction1: Top; Radial, Bottom; N-S, Direction2: Top; Circumferential, Bottom; E-W



**Table 7.3.1.1-3 Rebar and Concrete Stresses of RB: 6-min. after LOCA (1.5Pa): Winter:
Load ID = 6241(Selected Load Combination RB-8a) (Continued)**

Location	Element ID	Concrete Stress (MPa)		Primary Reinforcement Stress (MPa)				Allowable
		Calculated	Allowable	Calculated				
				Direction 1'		Direction 2'		
				In/Top	Out/Bottom	In/Top	Out/Bottom	
28 Pool Girder	123054	-6.8	-29.0	26.7	123.4	-0.9	111.8	369.8
@ Storage Pool	123154	-3.0	-29.0	45.6	68.3	45.8	57.6	369.8
29 Pool Girder	123062	-2.7	-28.4	28.2	49.9	9.8	53.3	365.0
@ Cavity	123162	-1.9	-28.4	87.7	99.7	55.1	46.6	365.0
30 Pool Girder	123067	-5.2	-28.4	-2.3	20.4	-17.7	12.4	365.0
@ Fuel Pool	123167	-5.6	-28.4	35.8	31.2	52.0	17.8	365.0
31 MS Tunnel	150122	-11.4	-29.3	14.7	142.2	-21.4	174.5	372.2
Wall and Slab	96611	-6.7	-29.3	-1.9	6.3	-9.3	189.6	372.2
	98614	-6.3	-29.3	2.1	11.0	-6.6	138.8	372.2
32 IC/PCCS	125051	-1.8	-28.3	75.4	43.9	80.0	51.3	364.7
Pool Wall	125151	-2.5	-28.3	74.0	42.6	54.8	34.6	364.7
in NS Dir.	125055	-0.9	-28.3	-2.4	2.2	1.4	20.6	364.7
	125155	-0.7	-28.3	-2.3	-2.7	14.3	2.4	364.7

Note: Negative value means compression.

Note *: Wall Below RCCV	Direction1: Hoop,	Direction2: Vertical
Exterior Wall	Direction1: Horizontal,	Direction2: Vertical
Slab/MS Tunnel Slab	Direction1: N-S,	Direction2: E-W
Pool Girder	Direction1: Horizontal,	Direction2: Vertical
MS Tunnel Wall	Direction1: Horizontal,	Direction2: Vertical
Basemat	Direction1: Top; Radial, Bottom; N-S,	Direction2: Top; Circumferential, Bottom; E-W



**Table 7.3.1.1-4 Rebar and Concrete Stresses of RB: 72-hr. after LOCA (1.5Pa): Winter:
Load ID = 6441(Selected Load Combination RB-8b)**

Location	Element ID	Concrete Stress (MPa)		Primary Reinforcement Stress (MPa)				Allowable
		Calculated	Allowable	Calculated				
				Direction 1'		Direction 2'		
				In/Top	Out/Bottom	In/Top	Out/Bottom	
18 Wall Below RCCV Bottom	6	-7.7	-29.3	-0.5	2.7	-9.8	-40.6	372.2
	13	-8.2	-29.3	-2.0	-3.0	-11.7	-44.6	372.2
	24	-7.3	-29.3	1.3	-2.3	-15.7	-41.5	372.2
19 Wall Below Below RCCV Mid-Height	806	-6.1	-29.3	12.4	6.6	-14.4	-34.6	372.2
	813	-6.8	-29.3	2.5	4.6	-19.9	-39.9	372.2
	824	-7.3	-29.3	1.6	2.7	-18.7	-41.6	372.2
20 Wall Below RCCV Top	1606	-14.1	-29.3	52.6	97.2	-68.0	47.9	372.2
	1613	-16.7	-29.3	46.4	94.3	-81.0	51.5	372.2
	1624	-17.9	-29.3	62.2	107.8	-82.3	54.7	372.2
21 Exterior Wall @ EL-11.50 ~10.50m	20011	-4.7	-29.3	37.8	8.3	54.8	-13.1	372.2
	20023	-4.7	-28.9	8.4	-13.4	14.3	-18.8	368.9
	30010	-2.8	-29.3	6.3	-5.6	29.2	-9.2	372.2
	30020	-2.4	-29.3	-5.8	4.0	-7.2	-13.5	372.2
	40001	-2.2	-29.3	-3.8	2.4	-7.9	-12.5	372.2
	40011	-2.2	-29.3	7.0	-2.7	14.1	-9.4	372.2
22 Exterior Wall @ EL4.65 ~6.60m	22011	-1.9	-29.3	110.3	93.1	68.3	65.9	372.2
	22023	-4.6	-29.3	45.5	9.7	-6.2	-22.3	372.2
	32010	-0.6	-29.3	77.9	137.7	-2.9	63.7	372.2
	32020	-4.1	-29.3	18.4	18.7	-14.6	42.4	372.2
	42001	-1.9	-29.3	32.8	12.3	-4.2	22.6	372.2
	42011	-3.6	-29.3	37.6	96.0	-8.6	40.5	372.2
23 Exterior Wall @ EL22.50 ~24.60m	24211	-0.6	-29.3	90.1	59.1	71.0	15.2	372.2
	24224	-3.2	-29.3	60.7	-10.1	23.0	19.0	372.2
	34210	-0.3	-29.3	121.8	219.3	31.2	157.0	372.2
	34220	-2.4	-29.3	75.3	-20.3	-16.2	38.7	372.2
	44201	-0.4	-29.3	84.8	2.1	21.1	49.5	372.2
24 Basemat @ Wall Below RCCV	90140	-1.8	-23.5	-11.9	4.5	1.1	7.5	372.2
	90182	-1.8	-23.5	-9.0	6.7	18.9	5.9	372.2
	90111	-2.4	-23.5	-13.8	4.7	18.5	9.8	372.2
25 Slab EL4.65m @ RCCV	93140	-11.1	-29.3	115.0	175.0	150.3	198.1	372.2
	93182	-15.5	-29.3	76.2	85.5	-73.2	41.7	372.2
	93111	-14.1	-29.3	-65.5	43.1	87.0	95.9	372.2
26 Slab EL17.5m @ RCCV	96144	-9.8	-29.3	206.7	216.9	273.0	269.0	372.2
	96186	-8.8	-29.3	143.8	164.4	-33.5	14.9	372.2
	96113	-13.9	-28.8	-88.5	19.9	103.1	128.6	368.2
27 Slab EL27.0m @ RCCV	98472	-7.1	-27.6	6.8	58.5	18.4	56.7	359.4
	98514	-7.1	-27.6	-21.0	34.8	-22.1	43.8	359.4
	98424	-6.4	-28.1	6.2	-43.6	64.9	31.9	363.0

Note: Negative value means compression.

Note *:	Wall Below RCCV	Direction1: Hoop,	Direction2: Vertical
	Exterior Wall	Direction1: Horizontal,	Direction2: Vertical
	Slab/MS Tunnel Slab	Direction1: N-S,	Direction2: E-W
	Pool Girder	Direction1: Horizontal,	Direction2: Vertical
	MS Tunnel Wall	Direction1: Horizontal,	Direction2: Vertical
	Basemat	Direction1: Top; Radial, Bottom; N-S,	Direction2: Top; Circumferential, Bottom; E-W



**Table 7.3.1.1-4 Rebar and Concrete Stresses of RB: 72-hr. after LOCA (1.5Pa): Winter:
Load ID = 6441(Selected Load Combination RB-8b) (Continued)**

Location	Element ID	Concrete Stress (MPa)		Primary Reinforcement Stress (MPa)				Allowable
		Calculated	Allowable	Calculated				
				Direction 1		Direction 2		
				In/Top	Out/Bottom	In/Top	Out/Bottom	
28 Pool Girder @ Storage Pool	123054	-7.6	-29.0	19.7	167.8	41.1	197.0	369.8
	123154	-3.9	-29.0	63.7	73.4	73.4	62.6	369.8
29 Pool Girder @ Cavity	123062	-13.6	-27.4	34.8	207.5	-3.8	190.6	358.3
	123162	-9.5	-27.4	60.8	255.4	11.2	180.2	358.3
30 Pool Girder @ Fuel Pool	123067	-11.3	-27.4	13.1	126.5	-24.0	114.1	358.3
	123167	-6.8	-27.4	22.9	138.3	16.3	113.9	358.3
31 MS Tunnel Wall and Slab	150122	-11.7	-29.3	16.4	133.9	-25.6	166.0	372.2
	96611	-6.4	-29.3	-2.2	3.3	-6.8	192.5	372.2
	98614	-6.7	-29.3	2.3	5.7	-10.0	127.0	372.2
32 IC/PCCS Pool Wall in NS Dir.	125051	-2.6	-25.4	-13.4	-11.9	-8.5	-3.0	343.4
	125151	-5.7	-25.4	82.6	60.7	85.1	61.8	343.4
	125055	-4.7	-25.4	-30.6	-29.2	-0.8	23.5	343.4
	125155	-3.7	-25.4	-25.3	-25.0	-1.1	0.8	343.4

Note: Negative value means compression.

Note *: Wall Below RCCV Direction1: Hoop, Direction2: Vertical
 Exterior Wall Direction1: Horizontal, Direction2: Vertical
 Slab/MS Tunnel Slab Direction1: N-S, Direction2: E-W
 Pool Girder Direction1: Horizontal, Direction2: Vertical
 MS Tunnel Wall Direction1: Horizontal, Direction2: Vertical
 Basemat Direction1: Top; Radial, Bottom; N-S, Direction2: Top; Circumferential, Bottom; E-W



**Table 7.3.1.1-5 Rebar and Concrete Stresses of RB: LOCA + SSE: 6-min. after: Winter:
Load ID = 7241(Site-Specific Seismic Load Combination RB-9a)**

Location	Element ID	Concrete Stress (MPa)		Primary Reinforcement Stress (MPa)				
		Calculated	Allowable	Calculated				Allowable
				Direction 1'		Direction 2'		
In/Top	Out/Bottom	In/Top	Out/Bottom					
18 Wall Below RCCV Bottom	6	-10.3	-29.3	51.7	65.3	-22.1	69.4	372.2
	13	-11.3	-29.3	25.6	57.2	-26.5	-62.3	372.2
	24	-10.8	-29.3	39.4	40.6	85.5	-30.0	372.2
19 Wall Below Below RCCV Mid-Height	806	-7.8	-29.3	95.6	47.8	58.6	-50.2	372.2
	813	-8.8	-29.3	59.3	40.6	38.0	-53.0	372.2
	824	-9.8	-29.3	79.6	48.0	71.2	-57.5	372.2
20 Wall Below RCCV Top	1606	-12.3	-29.3	87.4	117.0	-80.6	80.1	372.2
	1613	-14.7	-29.3	56.4	93.8	-92.2	50.8	372.2
	1624	-15.5	-29.3	83.9	115.7	-98.4	84.9	372.2
21 Exterior Wall @ EL-11.50 ~10.50m	20011	-8.6	-29.3	67.5	109.8	53.1	113.7	372.2
	20023	-6.3	-28.9	12.8	-19.5	20.4	-25.3	368.9
	30010	-5.6	-29.3	55.6	46.2	34.2	76.5	372.2
	30020	-3.9	-29.3	-11.7	10.7	-7.6	-18.6	372.2
	40001	-4.1	-29.3	21.0	8.4	-6.3	23.2	372.2
22 Exterior Wall @ EL4.65 ~6.60m	40011	-5.7	-29.3	42.4	42.6	26.6	92.9	372.2
	22011	-8.6	-29.3	152.6	142.2	255.4	135.4	372.2
	22023	-8.9	-29.3	124.6	56.7	70.0	47.0	372.2
	32010	-4.3	-29.3	175.1	199.8	158.3	236.9	372.2
	32020	-7.4	-29.3	112.0	91.6	190.9	270.6	372.2
23 Exterior Wall @ EL22.50 ~24.60m	42001	-7.4	-29.3	120.2	68.4	209.2	219.0	372.2
	42011	-6.5	-29.3	111.8	150.8	182.2	160.9	372.2
	24211	-5.6	-29.3	188.4	126.0	227.1	119.9	372.2
	24224	-10.8	-29.3	137.2	135.3	298.7	155.4	372.2
	34210	-4.8	-29.3	168.4	213.0	107.6	188.6	372.2
24 Basemat @ Wall Below RCCV	34220	-3.7	-29.3	108.0	73.6	138.0	172.5	372.2
	44201	-4.0	-29.3	129.3	91.1	151.8	196.1	372.2
	90140	-4.8	-23.5	152.3	-2.9	25.1	9.7	372.2
	90182	-3.8	-23.5	25.2	59.4	45.5	33.0	372.2
25 Slab EL4.65m @ RCCV	90111	-4.3	-23.5	-21.8	27.9	44.1	54.2	372.2
	93140	-10.5	-29.3	114.3	142.3	103.9	156.3	372.2
	93182	-17.5	-29.3	42.2	84.3	-73.2	91.6	372.2
26 Slab EL17.5m @ RCCV	93111	-16.2	-29.3	-67.4	85.8	55.9	90.2	372.2
	96144	-10.8	-29.3	204.2	192.4	217.6	230.0	372.2
	96186	-9.0	-29.3	103.8	149.1	-41.3	-35.7	372.2
27 Slab EL27.0m @ RCCV	96113	-15.6	-28.8	-107.0	75.4	94.9	135.1	368.2
	98472	-9.6	-29.1	77.7	61.6	61.5	60.3	370.3
	98514	-4.9	-29.1	18.4	45.4	-18.7	36.9	370.3
	98424	-8.8	-28.1	-23.4	-46.4	-20.3	-11.3	363.0

Note: Negative value means compression.

Note *: Wall Below RCCV

Exterior Wall
Slab/MS Tunnel Slab
Pool Girder
MS Tunnel Wall
Basemat

Direction1: Hoop,

Direction1: Horizontal,

Direction1: N-S,

Direction1: Horizontal,

Direction1: Horizontal,

Direction1: Top; Radial, Bottom; N-S,

Direction2: Vertical

Direction2: Vertical

Direction2: E-W

Direction2: Vertical

Direction2: Vertical

Direction2: Top; Circumferential, Bottom; E-W



**Table 7.3.1.1-5 Rebar and Concrete Stresses of RB: LOCA + SSE: 6-min. after: Winter:
Load ID = 7241(Site-Specific Seismic Load Combination RB-9a) (Continued)**

Location	Element ID	Concrete Stress (MPa)		Primary Reinforcement Stress (MPa)				Allowable
		Calculated	Allowable	Calculated				
				Direction 1'		Direction 2'		
				In/Top	Out/Bottom	In/Top	Out/Bottom	
28 Pool Girder @ Storage Pool	123054	-8.9	-29.0	23.8	112.9	-30.5	123.2	369.8
	123154	-3.2	-29.0	92.4	134.7	75.3	99.2	369.8
29 Pool Girder @ Cavity	123062	-3.4	-28.4	34.2	35.9	45.7	38.8	365.0
	123162	-2.1	-28.4	96.8	63.2	40.7	53.8	365.0
30 Pool Girder @ Fuel Pool	123067	-7.4	-28.4	-4.1	28.9	-35.3	-12.2	365.0
	123167	-6.7	-28.4	28.4	41.4	48.2	17.9	365.0
31 MS Tunnel Wall and Slab	150122	-12.5	-29.3	17.6	164.2	-22.6	195.8	372.2
	96611	-8.9	-29.3	-2.0	23.4	-13.7	226.8	372.2
	98614	-7.9	-29.3	4.0	27.6	-6.0	178.5	372.2
32 IC/PCCS Pool Wall in NS Dir.	125051	-3.8	-28.3	79.5	47.4	98.5	74.8	364.7
	125151	-3.8	-28.3	75.9	46.0	47.2	30.6	364.7
	125055	-1.6	-28.3	27.2	17.8	37.0	47.8	364.7
	125155	-1.8	-28.3	22.9	14.4	39.4	15.3	364.7

Note: Negative value means compression.

Note *:	Wall Below RCCV	Direction1: Hoop,	Direction2: Vertical
	Exterior Wall	Direction1: Horizontal,	Direction2: Vertical
	Slab/MS Tunnel Slab	Direction1: N-S,	Direction2: E-W
	Pool Girder	Direction1: Horizontal,	Direction2: Vertical
	MS Tunnel Wall	Direction1: Horizontal,	Direction2: Vertical
	Basemat	Direction1: Top; Radial, Bottom; N-S,	Direction2: Top; Circumferential, Bottom; E-W



**Table 7.3.1.1-6 Rebar and Concrete Stresses of RB: LOCA + SSE: 72-hr. after: Winter:
Load ID = 7441(Site-Specific Seismic Load Combination RB-9b)**

Location	Element ID	Concrete Stress (MPa)		Primary Reinforcement Stress (MPa)					
		Calculated	Allowable	Calculated				Allowable	
				Direction 1'		Direction 2'			
In/Top	Out/Bottom	In/Top	Out/Bottom						
18 Wall Below RCCV Bottom	6	-11.6	-29.3	37.8	57.6	-17.6	-64.0	372.2	
	13	-13.1	-29.3	24.3	40.2	-18.1	-70.5	372.2	
	24	-12.5	-29.3	20.3	50.6	-19.8	-69.2	372.2	
19 Wall Below Below RCCV Mid-Height	806	-8.5	-29.3	96.4	47.3	54.7	-54.1	372.2	
	813	-9.7	-29.3	61.3	46.4	-34.0	-57.6	372.2	
	824	-10.5	-29.3	82.1	45.6	74.1	-60.9	372.2	
20 Wall Below RCCV Top	1606	-13.4	-29.3	107.1	134.1	-85.0	95.2	372.2	
	1613	-16.2	-29.3	76.8	111.6	-98.5	61.3	372.2	
	1624	-16.7	-29.3	104.2	134.0	-103.6	101.6	372.2	
21 Exterior Wall @ EL-11.50 ~-10.50m	20011	-8.2	-29.3	116.6	40.7	65.7	104.4	372.2	
	20023	-6.2	-28.9	11.6	-19.4	20.8	-25.1	368.9	
	30010	-5.6	-29.3	58.2	48.0	38.5	76.7	372.2	
	30020	-4.2	-29.3	-12.0	11.1	-7.5	-18.0	372.2	
	40001	-4.3	-29.3	18.0	11.1	-6.8	-17.8	372.2	
	40011	-5.9	-29.3	43.2	47.8	31.6	91.4	372.2	
22 Exterior Wall @ EL4.65 ~-6.60m	22011	-7.0	-29.3	246.0	202.2	235.8	303.4	372.2	
	22023	-8.7	-29.3	131.6	56.8	85.0	54.4	372.2	
	32010	-4.6	-29.3	186.7	231.6	135.2	221.2	372.2	
	32020	-5.3	-29.3	56.2	122.7	198.5	280.1	372.2	
	42001	-7.4	-29.3	102.2	85.9	206.6	216.1	372.2	
	42011	-6.3	-29.3	124.3	160.9	196.0	163.9	372.2	
23 Exterior Wall @ EL22.50 ~-24.60m	24211	-5.7	-29.3	244.4	148.0	259.4	123.7	372.2	
	24224	-10.2	-29.3	146.8	106.0	319.7	132.2	372.2	
	34210	-4.8	-29.3	191.9	237.1	106.8	232.9	372.2	
	34220	-5.3	-29.3	133.5	21.5	146.4	139.7	372.2	
	44201	-3.9	-29.3	185.3	57.8	193.6	194.8	372.2	
24 Basemat @ Wall Below RCCV	90140	-5.2	-23.5	115.0	3.2	4.8	-8.3	372.2	
	90182	-3.9	-23.5	23.0	32.9	87.2	39.5	372.2	
	90111	-4.5	-23.5	24.6	37.0	74.5	27.4	372.2	
25 Slab EL4.65m @ RCCV	93140	-13.1	-29.3	144.1	195.2	147.9	204.7	372.2	
	93182	-21.4	-29.3	60.4	100.5	-89.1	108.2	372.2	
	93111	-19.4	-29.3	-80.8	101.4	70.8	104.6	372.2	
26 Slab EL17.5m @ RCCV	96144	-10.9	-29.3	211.9	245.0	256.7	266.9	372.2	
	96186	-11.0	-29.3	130.2	187.1	-52.3	40.1	372.2	
	96113	-16.4	-28.8	-110.3	63.4	115.2	151.9	368.2	
27 Slab EL27.0m @ RCCV	98472	-9.7	-27.6	57.0	84.3	77.8	85.8	359.4	
	98514	-9.8	-27.6	-21.9	34.9	-31.4	64.2	359.4	
	98424	-9.3	-28.1	106.9	-73.3	175.0	64.4	363.0	

Note: Negative value means compression.

Note *: Wall Below RCCV

Exterior Wall
Slab/MS Tunnel Slab
Pool Girder
MS Tunnel Wall
Basemat

Direction1: Hoop,

Direction1: Horizontal,

Direction1: N-S,

Direction1: Horizontal,

Direction1: Horizontal,

Direction1: Top; Radial, Bottom; N-S,

Direction2: Vertical

Direction2: Vertical

Direction2: E-W

Direction2: Vertical

Direction2: Vertical

Direction2: Top; Circumferential, Bottom; E-W



**Table 7.3.1.1-6 Rebar and Concrete Stresses of RB: LOCA + SSE: 72-hr. after: Winter:
Load ID = 7441(Site-Specific Seismic Load Combination RB-9b) (Continued)**

Location	Element ID	Concrete Stress (MPa)		Primary Reinforcement Stress (MPa)				Allowable
		Calculated	Allowable	Calculated				
				Direction 1*		Direction 2*		
				In/Top	Out/Bottom	In/Top	Out/Bottom	
28 Pool Girder @ Storage Pool	123054	-7.1	-29.0	53.2	171.9	119.9	252.9	369.8
	123154	-3.7	-29.0	76.1	161.8	84.3	114.3	369.8
29 Pool Girder @ Cavity	123062	-13.3	-27.4	35.8	222.8	7.5	187.8	358.3
	123162	-10.0	-27.4	59.2	271.6	9.0	158.0	358.3
30 Pool Girder @ Fuel Pool	123067	-13.7	-27.4	3.8	103.3	-47.5	58.6	358.3
	123167	-7.7	-27.4	21.0	136.4	9.6	111.1	358.3
31 MS Tunnel Wall and Slab	150122	-12.8	-29.3	19.2	156.0	-26.7	187.4	372.2
	96611	-8.7	-29.3	-2.3	21.2	-11.6	230.6	372.2
	98614	-8.1	-29.3	4.1	11.2	-13.4	144.4	372.2
32 IC/PCCS Pool Wall in NS Dir.	125051	-5.2	-25.4	-13.3	-11.0	-24.4	-16.3	343.4
	125151	-6.7	-25.4	75.9	59.2	68.2	51.8	343.4
	125055	-5.1	-25.4	-32.5	-30.2	7.1	21.4	343.4
	125155	-5.0	-25.4	-33.3	-32.2	-2.5	2.1	343.4

Note: Negative value means compression.

Note *: Wall Below RCCV Direction1: Hoop, Direction2: Vertical
 Exterior Wall Direction1: Horizontal, Direction2: Vertical
 Slab/MS Tunnel Slab Direction1: N-S, Direction2: E-W
 Pool Girder Direction1: Horizontal, Direction2: Vertical
 MS Tunnel Wall Direction1: Horizontal, Direction2: Vertical
 Basemat Direction1: Top; Radial, Bottom; N-S, Direction2: Top; Circumferential, Bottom; E-W



Table 7.3.1.1-7 Maximum Stress Ratios for Flexure and Membrane Forces

Location	Element ID	Concrete		Primary Reinforcement							
		σ/σ_a	Load ID	Direction 1'				Direction 2'			
				In/Top		Out/Bottom		In/Top		Out/Bottom	
				σ/σ_a	Load ID	σ/σ_a	Load ID	σ/σ_a	Load ID	σ/σ_a	Load ID
18 Wall	6	0.433	7501	0.249	7721	0.182	7641	0.250	7851	0.203	7621
Below RCCV	13	0.518	7501	0.206	8081	0.157	7721	0.250	7851	0.250	7661
Bottom	24	0.568	7501	0.202	7992	0.172	7672	0.252	7642	0.241	7671
19 Wall	806	0.298	8514	0.284	8021	0.189	7673	0.209	7671	0.183	7651
Below RCCV	813	0.339	8514	0.177	9011	0.132	9011	0.120	7651	0.206	7651
Mid-Height	824	0.367	8514	0.223	7921	0.140	7651	0.200	7971	0.237	7651
20 Wall	1606	0.542	6241	0.383	7701	0.364	7471	0.380	7701	0.264	7971
Below RCCV	1613	0.625	6341	0.263	7651	0.302	7471	0.335	7701	0.210	8061
Top	1624	0.639	8507	0.378	7751	0.363	7471	0.380	7602	0.289	8001
21 Exterior Wall	20011	0.338	7251	0.391	8514	0.298	7821	0.568	8514	0.314	7721
@ EL-11.50	20023	0.467	7492	0.214	7492	0.099	7491	0.228	7992	0.097	7492
~10.50m	30010	0.302	7501	0.183	9014	0.196	7961	0.209	7961	0.213	7921
	30020	0.192	7211	0.048	8061	0.111	7261	0.061	7601	0.157	2511
	40001	0.284	7481	0.078	8001	0.170	7461	0.074	7481	0.209	2511
	40011	0.338	7501	0.122	7971	0.143	8011	0.176	7961	0.271	9011
22 Exterior Wall	22011	0.388	7561	0.728	8513	0.591	8513	0.723	7871	0.827	8511
@ EL4.65	22023	0.391	8511	0.367	8001	0.345	7701	0.487	7601	0.526	7601
~6.60m	32010	0.235	7131	0.552	7482	0.635	8514	0.525	7173	0.714	8511
	32020	0.257	7371	0.429	7431	0.375	9012	0.719	7831	0.802	7411
	42001	0.269	7201	0.385	7751	0.253	7991	0.698	9012	0.677	7113
	42011	0.260	7501	0.504	8511	0.518	8511	0.571	9014	0.616	8511
23 Exterior Wall	24211	0.336	7501	0.662	7461	0.571	8511	0.725	7461	0.630	8513
@ EL22.50	24224	0.436	7961	0.699	7481	0.451	7601	0.878	7632	0.848	8512
~24.60m	34210	0.231	5026	0.655	7482	0.909	7482	0.520	8514	0.854	7482
	34220	0.195	7482	0.491	8511	0.250	8512	0.484	7261	0.617	8511
	44201	0.230	8502	0.498	7441	0.312	7581	0.545	7461	0.571	7581

Note *: Wall Below RCCV Direction1 : Hoop, Direction2 : Vertical
 Exterior Wall Direction1 : Horizontal, Direction2 : Vertical
 Slab Direction1 : N-S, Direction2 : E-W
 Pool Girder Direction1 : Horizontal, Direction2 : Vertical
 MS Tunnel Wall Direction1 : Horizontal, Direction2 : Vertical
 MS Tunnel Slab Direction1 : N-S, Direction2 : E-W

σ and σ_a are calculated and allowable stress.



Table 7.3.1.1-7 Maximum Stress Ratios for Flexure and Membrane Forces (Continued)

Location	Element ID	Concrete		Primary Reinforcement							
		σ/σ_a	Load ID	Direction 1'				Direction 2'			
				In/Top		Out/Bottom		In/Top		Out/Bottom	
				σ/σ_a	Load ID	σ/σ_a	Load ID	σ/σ_a	Load ID	σ/σ_a	Load ID
24 Basemat @ Wall Below RCCV	90140	0.500	7571	0.474	7671	0.383	7672	0.157	7172	0.250	2515
	90182	0.244	7491	0.100	7601	0.181	7921	0.254	9014	0.166	7491
	90111	0.237	7571	0.077	7672	0.141	7581	0.214	7841	0.150	7821
25 Slab EL4.65m @ RCCV	93140	0.478	8514	0.427	7811	0.524	7941	0.406	6421	0.554	8514
	93182	0.741	8514	0.205	6441	0.270	8511	0.257	7351	0.326	8514
	93111	0.689	8514	0.218	7602	0.320	8514	0.235	8507	0.283	8514
26 Slab EL17.5m @ RCCV	96144	0.412	8511	0.600	6971	0.705	8514	0.757	8508	0.773	8507
	96186	0.483	8513	0.442	7431	0.550	8511	0.256	7103	0.240	8511
	96113	0.588	8513	0.428	7102	0.365	7521	0.440	7103	0.442	8511
27 Slab EL27.0m @ RCCV	98472	0.890	8512	0.869	8512	0.518	8511	0.875	8512	0.514	8511
	98514	0.668	8513	0.402	8513	0.291	8511	0.313	8514	0.216	7331
	98424	0.844	8514	0.685	7501	0.436	7851	0.720	8514	0.404	8511
28 Pool Girder @ Storage Pool	123054	0.669	8512	0.327	8507	0.631	8501	0.531	7481	0.721	9011
	123154	0.455	8512	0.385	8514	0.724	8513	0.306	7431	0.385	8505
29 Pool Girder @ Cavity	123062	0.464	6971	0.295	8514	0.602	7421	0.298	7501	0.514	6421
	123162	0.365	7461	0.432	7131	0.735	7481	0.165	6142	0.486	6421
30 Pool Girder @ Fuel Pool	123067	0.888	8513	0.805	8506	0.554	6431	0.725	9005	0.512	6911
	123167	0.601	8505	0.772	9005	0.479	6445	0.676	8505	0.431	6431
31 MS Tunnel Wall and Slab	150122	0.517	2021	0.064	7501	0.491	2521	0.072	7421	0.709	7521
	96611	0.383	7521	0.155	7101	0.143	7521	0.155	7851	0.651	7521
	98614	0.284	7371	0.058	8514	0.120	7521	0.498	8511	0.480	7173
32 IC/PCCS Pool Wall in NS Dir.	125051	0.272	9005	0.544	8505	0.628	8512	0.748	8513	0.773	8512
	125151	0.292	9012	0.520	8513	0.609	8512	0.610	8505	0.605	8512
	125055	0.340	8512	0.380	8514	0.458	8512	0.408	8514	0.483	8512
	125155	0.287	9003	0.377	8514	0.473	8512	0.276	8514	0.310	8512

Note *: Wall Below RCCV Direction1 : Hoop, Direction2 : Vertical
 Exterior Wall Direction1 : Horizontal, Direction2 : Vertical
 Slab Direction1 : N-S, Direction2 : E-W
 Pool Girder Direction1 : Horizontal, Direction2 : Vertical
 MS Tunnel Wall Direction1 : Horizontal, Direction2 : Vertical
 MS Tunnel Slab Direction1 : N-S, Direction2 : E-W

σ and σ_a are calculated and allowable stress.

**Table 7.3.1.2-1 Membrane Compressive Forces of RB**

Location	Element ID	Load ID	Section Forces (MN/m)			Thickness h (m)	Calculated Concrete Stress (MPa)				Allowable Stress σ_a (MPa)	σ_c/σ_a
			Nx	Ny	Nxy		σ_x	σ_y	τ_{xy}	σ_c		
18 Wall Below RCCV Bottom	6	2001	-1.563	-8.189	-0.217	2.0	-0.782	-4.095	-0.109	-4.098	-10.4	0.396
	13	2001	-1.451	-6.579	0.270	2.0	-0.726	-3.290	0.135	-3.297	-10.4	0.319
	24	2001	-1.218	-7.262	-0.348	2.0	-0.609	-3.631	-0.174	-3.641	-10.4	0.352
19 Wall Below RCCV Mid-Height	806	2001	-1.288	-7.032	-0.299	2.0	-0.644	-3.516	-0.150	-3.524	-10.4	0.340
	813	8514	-2.711	-16.363	-1.177	2.0	-1.356	-8.182	-0.589	-8.232	-25.9	0.318
	824	2001	-1.949	-7.215	-0.307	2.0	-0.975	-3.607	-0.154	-3.616	-10.4	0.349
20 Wall Below RCCV Top	1606	2001	-1.332	-6.426	0.251	2.0	-0.666	-3.213	0.125	-3.219	-10.4	0.311
	1613	8514	3.797	-16.590	2.179	2.0	1.899	-8.295	1.089	-8.410	-25.9	0.325
	1624	8514	4.784	-17.402	-2.777	2.0	2.392	-8.701	-1.389	-8.872	-25.9	0.343
21 Exterior Wall @ EL-11.50 ~10.50m	20011	7501	-4.083	-7.207	-2.927	2.0	-2.042	-3.604	-1.463	-4.482	-20.7	0.217
	20023	7491	-6.833	-6.195	3.372	2.0	-3.417	-3.098	1.686	-4.951	-25.9	0.191
	30010	7561	-4.398	-4.341	-1.189	2.0	-2.199	-2.171	-0.594	-2.779	-20.7	0.134
	30020	8511	-1.819	-5.030	-2.079	2.0	-0.909	-2.515	-1.040	-3.026	-25.9	0.117
	40001	7251	-1.549	-3.724	1.731	2.0	-0.774	-1.862	0.866	-2.340	-20.7	0.113
	40011	2001	-1.512	-3.352	-0.161	2.0	-0.756	-1.676	-0.081	-1.683	-10.4	0.163
22 Exterior Wall @ EL4.65 ~6.60m	22011	7501	-1.371	-8.634	4.792	1.5	-0.914	-5.756	3.195	-7.343	-20.7	0.355
	22023	7492	-0.844	-12.174	-6.207	1.5	-0.563	-8.116	-4.138	-9.942	-25.9	0.384
	32010	7501	-1.492	-5.565	3.134	1.5	-0.995	-3.710	2.090	-4.845	-20.7	0.234
	32020	7251	-0.538	-8.214	2.536	1.5	-0.358	-5.476	1.690	-5.984	-20.7	0.289
	42001	7251	-0.399	-8.353	2.597	1.5	-0.266	-5.569	1.731	-6.084	-20.7	0.294
	42011	7501	-1.665	-6.683	-3.737	1.5	-1.110	-4.455	-2.491	-5.783	-20.7	0.279
23 Exterior Wall @ EL22.50 ~24.60m	24211	7561	-1.136	-6.516	3.804	1.5	-0.757	-4.344	2.536	-5.657	-20.7	0.273
	24224	7301	-0.534	-10.393	3.951	1.5	-0.356	-6.929	2.634	-7.854	-20.7	0.379
	34210	7561	-1.067	-2.848	3.519	1.5	-0.712	-1.899	2.346	-3.725	-20.7	0.180
	34220	7351	0.222	-4.563	-2.222	1.5	0.148	-3.042	-1.481	-3.624	-20.7	0.175
	44201	7251	0.193	-5.099	-2.604	1.5	0.128	-3.399	-1.736	-4.110	-20.7	0.199
24 Basemat @ Wall Below RCCV	90140	7151	-6.079	-3.769	2.214	4.0	-1.520	-0.942	0.554	-1.855	-16.6	0.112
	90182	2001	-3.496	-2.684	-0.125	4.0	-0.874	-0.671	-0.031	-0.879	-8.3	0.106
	90111	2001	-4.049	-3.155	0.037	4.0	-1.012	-0.789	0.009	-1.013	-8.3	0.122
25 Slab EL4.65m @ RCCV	93140	8514	-2.967	0.452	3.622	1.0	-2.967	0.452	3.622	-5.263	-25.9	0.203
	93182	8511	1.567	-4.979	-0.427	1.0	1.567	-4.979	-0.427	-5.007	-25.9	0.193
	93111	7421	-4.428	1.759	-0.287	1.0	-4.428	1.759	-0.287	-4.441	-25.9	0.172
26 Slab EL17.5m @ RCCV	96144	8508	0.111	0.762	4.690	1.0	0.111	0.762	4.690	-4.265	-25.9	0.165
	96186	8514	2.343	-6.951	-2.172	1.0	2.343	-6.951	-2.172	-7.434	-25.9	0.287
	96113	6483	-9.995	2.744	-1.583	1.6	-6.247	1.715	-0.989	-6.368	-25.9	0.246
27 Slab EL27.0m @ RCCV	98472	8513	-10.808	-6.087	12.587	1.5	-7.205	-4.058	8.391	-14.169	-25.9	0.548
	98514	8511	4.015	-5.431	-2.348	1.5	2.676	-3.621	-1.566	-3.989	-25.9	0.154
	98424	8512	-29.098	2.108	-5.888	2.4	-12.124	0.878	-2.453	-12.572	-25.9	0.486
28 Pool Girder @ Storage Pool	123054	8512	-1.321	-15.008	2.545	1.6	-0.826	-9.380	1.591	-9.666	-25.9	0.374
	123154	8512	-2.825	-5.733	4.099	1.6	-1.766	-3.583	2.562	-5.393	-25.9	0.208
29 Pool Girder @ Cavity	123062	8513	-3.715	-9.482	-1.757	1.6	-2.322	-5.926	-1.098	-6.235	-25.9	0.241
	123162	8513	-3.415	-7.503	-4.804	1.6	-2.134	-4.689	-3.002	-6.674	-25.9	0.258
30 Pool Girder @ Fuel Pool	123067	8511	-4.292	-11.854	-6.899	1.6	-2.683	-7.409	-4.312	-9.962	-25.9	0.385
	123167	8511	-3.818	-5.177	-6.491	1.6	-2.386	-3.236	-4.057	-6.890	-25.9	0.266
31 MS Tunnel Wall and Slab	150122	2021	-0.027	-0.558	1.494	1.3	-0.021	-0.429	1.150	-1.393	-15.5	0.090
	96611	8511	-0.742	2.325	-0.083	1.6	-0.464	1.453	-0.052	-0.465	-25.9	0.018
	98614	8512	-1.805	2.572	-0.676	2.4	-0.752	1.072	-0.282	-0.795	-25.9	0.031
32 IC/PCCS Pool Wall in NS Dir.	125051	7501	-0.260	-2.951	-2.191	1.0	-0.260	-2.951	-2.191	-4.177	-20.7	0.202
	125151	7441	-2.048	-2.214	3.305	1.0	-2.048	-2.214	3.305	-5.437	-25.9	0.210
	125055	8513	-5.767	-0.210	-0.799	1.0	-5.767	-0.210	-0.799	-5.879	-25.9	0.227
	125155	8513	-6.767	-0.414	-0.774	1.0	-6.767	-0.414	-0.774	-6.860	-25.9	0.265

Note: Positive value means tension.



Table 7.3.1.3-1 Transverse Shear of RB

Location	Element ID	Load ID	d (m)	pv (%)	Shear Force (MN/m)				Vu/φVn
					Vu	Vc	Vs	φVn	
18 Wall Below RCCV Bottom	6	7461	1.62	0.721	2.16	4.96	4.84	8.33	0.259
	13	7461	1.62	0.721	2.24	4.82	4.84	8.21	0.273
	24	7501	1.59	0.721	2.30	4.63	4.73	7.95	0.289
19 Wall Below Below RCCV Mid-Height	806	7992	1.57	0.270	0.12	0.15	1.75	1.61	0.077
	813	8514	1.57	0.270	0.91	4.86	1.75	5.62	0.162
	824	8514	1.57	0.270	1.02	5.00	1.75	5.74	0.177
20 Wall Below RCCV Top	1606	6421	1.57	0.540	4.05	4.00	3.50	6.37	0.635
	1613	6471	1.57	0.540	4.68	4.24	3.50	6.57	0.712
	1624	8507	1.57	0.540	5.07	4.37	3.50	6.69	0.759
21 Exterior Wall @ EL-11.50 ~10.50m	20011	8512	1.63	0.484	1.87	0.64	3.27	3.32	0.562
	20023	8514	1.58	0.484	1.46	1.85	3.15	4.25	0.342
	30010	7511	1.68	0.710	1.63	2.33	4.93	6.17	0.265
	30020	7511	1.69	0.710	1.20	3.52	4.96	7.21	0.166
	40001	7571	1.70	0.710	1.44	2.08	4.98	6.00	0.239
	40011	7501	1.69	0.710	2.46	3.91	4.97	7.55	0.325
22 Exterior Wall @ EL4.65 ~6.60m	22011	8514	1.15	0.484	1.00	0.00	2.31	1.96	0.513
	22023	9014	1.16	0.484	0.71	1.10	2.33	2.92	0.242
	32010	8514	1.09	0.177	0.36	0.00	0.80	0.68	0.524
	32020	6435	1.25	0.177	0.25	0.29	0.91	1.02	0.242
	42001	7411	1.25	0.242	0.84	0.85	1.25	1.79	0.468
	42011	7711	1.09	0.242	0.29	0.27	1.09	1.16	0.252
23 Exterior Wall @ EL22.50 ~24.60m	24211	8511	1.09	0.968	2.78	0.00	4.25	3.61	0.771
	24224	7211	1.10	0.484	1.79	0.00	2.21	1.88	0.954
	34210	8512	1.09	0.177	0.52	0.00	0.80	0.68	0.761
	34220	8503	1.26	0.710	1.21	0.94	3.69	3.93	0.308
	44201	4021	1.26	0.968	2.40	0.95	4.89	4.96	0.483
24 Basemat @ Wall Below RCCV	90140	7571	3.53	0.801	6.36	4.46	11.69	13.73	0.463
	90182	7331	3.51	0.801	5.34	5.96	11.63	14.95	0.357
	90111	8514	3.55	0.801	5.12	6.17	11.76	15.24	0.336
25 Slab EL4.65m @ RCCV	93140	8514	0.80	0.500	0.30	0.22	1.65	1.59	0.192
	93182	8514	0.80	0.500	2.30	1.36	1.65	2.56	0.899
	93111	8514	0.80	0.500	1.97	1.24	1.65	2.46	0.800
26 Slab EL17.5m @ RCCV	96144	7103	0.80	0.500	0.32	0.82	1.65	2.10	0.153
	96186	8511	0.80	0.500	1.41	2.18	1.65	3.25	0.432
	96113	7492	1.34	0.500	1.75	1.59	2.76	3.69	0.474
27 Slab EL27.0m @ RCCV	98472	8513	1.21	0.968	3.50	4.56	4.73	7.90	0.443
	98514	8514	1.21	0.968	3.49	1.88	4.72	5.61	0.623
	98424	8512	1.95	0.968	10.86	7.00	7.62	12.42	0.874
28 Pool Girder @ Storage Pool	123054	9011	1.25	0.484	1.25	1.35	2.50	3.28	0.382
	123154	8503	1.25	0.484	0.94	1.40	2.50	3.32	0.284
29 Pool Girder @ Cavity	123062	7361	1.25	0.242	0.43	1.30	1.25	2.17	0.200
	123162	7331	1.23	0.242	0.30	0.33	1.23	1.32	0.224
30 Pool Girder @ Fuel Pool	123067	7441	1.28	0.484	1.02	4.00	2.57	5.58	0.182
	123167	8513	1.24	0.484	0.75	0.98	2.48	2.94	0.254
31 MS Tunnel Wall and Slab	150122	8512	1.06	0.177	0.53	0.73	0.78	1.28	0.416
	96611	8514	1.34	0.500	0.62	1.65	2.76	3.75	0.166
	98614	8511	1.95	0.500	1.44	3.51	4.04	6.41	0.224
32 IC/PCCS Pool Wall in NS Direction	125051	8512	0.81	0.250	0.28	0.82	0.83	1.41	0.201
	125151	8513	0.82	0.250	0.24	0.49	0.85	1.13	0.209
	125055	8514	0.80	0.250	0.34	0.65	0.83	1.25	0.275
	125155	8512	0.79	0.250	0.29	0.71	0.82	1.30	0.221



Table 7.3.1.3-2 Transverse Shear of RB for DCD Load Combinations

Location	Element ID	Load ID	Load ID	d (m)	pv (%)	Shear Force (MN/m)				Vu/φVn
						Vu	Vc	Vs	φVn	
18 Wall Below RCCV Bottom	6	7741	RB-9a	1.59	0.721	1.08	1.35	4.73	5.17	0.209
	13	7741	RB-9a	1.59	0.721	1.34	1.97	4.73	5.70	0.235
	24	7941	RB-9b	1.59	0.721	1.13	2.35	4.73	6.02	0.187
19 Wall Below Below RCCV Mid-Height	806	7441	RB-9b	1.57	0.270	0.32	4.56	1.75	5.37	0.060
	813	7441	RB-9b	1.57	0.270	0.82	4.85	1.75	5.62	0.146
	824	7441	RB-9b	1.57	0.270	0.87	4.91	1.75	5.66	0.153
20 Wall Below RCCV Top	1606	6441	RB-8b	1.57	0.540	4.04	4.02	3.50	6.39	0.632
	1613	6441	RB-8b	1.57	0.540	4.68	4.26	3.50	6.59	0.710
	1624	6441	RB-8b	1.57	0.540	4.95	4.28	3.50	6.61	0.749
21 Exterior Wall @ EL-11.50 ~10.50m	20011	7441	RB-9b	1.63	0.484	1.79	2.74	3.27	5.11	0.351
	20023	7441	RB-9b	1.58	0.484	1.31	3.15	3.16	5.37	0.243
	30010	7241	RB-9a	1.69	0.710	1.37	2.78	4.97	6.59	0.208
	30020	7241	RB-9a	1.71	0.710	0.76	3.16	5.02	6.95	0.109
	40001	7241	RB-9a	1.71	0.710	0.89	3.29	5.01	7.05	0.126
	40011	7241	RB-9a	1.69	0.710	1.81	3.50	4.97	7.20	0.252
22 Exterior Wall @ EL4.65 ~6.60m	22011	7441	RB-9b	1.15	0.484	0.93	0.00	2.31	1.96	0.475
	22023	7241	RB-9a	1.18	0.484	0.73	3.55	2.36	5.02	0.146
	32010	7241	RB-9a	1.09	0.177	0.29	0.05	0.80	0.72	0.401
	32020	7941	RB-9b	1.26	0.177	0.25	0.29	0.92	1.03	0.239
	42001	7241	RB-9a	1.19	0.242	0.52	0.80	1.19	1.69	0.310
	42011	7941	RB-9b	1.09	0.242	0.20	0.23	1.09	1.13	0.177
23 Exterior Wall @ EL22.50 ~24.60m	24211	7241	RB-9a	1.05	0.968	1.34	0.06	4.10	3.53	0.379
	24224	7941	RB-9b	1.05	0.484	1.21	0.00	2.11	1.79	0.677
	34210	7241	RB-9a	1.09	0.177	0.27	0.57	0.80	1.16	0.234
	34220	4021	RB-4	1.26	0.710	0.46	1.11	3.69	4.08	0.113
	44201	4021	RB-4	1.26	0.968	2.40	0.95	4.89	4.96	0.483
24 Basemat @ Wall Below RCCV	90140	7441	RB-9b	3.53	0.801	6.34	6.75	11.70	15.69	0.404
	90182	7441	RB-9b	3.51	0.801	5.22	5.88	11.63	14.88	0.351
	90111	7441	RB-9b	3.55	0.801	4.42	6.25	11.76	15.31	0.289
25 Slab EL4.65m @ RCCV	93140	7441	RB-9b	0.80	0.500	0.29	0.17	1.65	1.55	0.188
	93182	7441	RB-9b	0.80	0.500	2.25	1.60	1.65	2.76	0.815
	93111	7441	RB-9b	0.80	0.500	1.86	1.45	1.65	2.63	0.707
26 Slab EL17.5m @ RCCV	96144	7441	RB-9b	0.80	0.500	0.32	1.91	1.65	3.03	0.105
	96186	7441	RB-9b	0.80	0.500	1.03	2.13	1.65	3.21	0.319
	96113	7241	RB-9a	1.34	0.500	2.29	3.65	2.76	5.45	0.420
27 Slab EL27.0m @ RCCV	98472	7441	RB-9b	1.21	0.968	2.03	3.30	4.73	6.83	0.297
	98514	7441	RB-9b	1.21	0.968	1.21	1.63	4.73	5.41	0.223
	98424	7441	RB-9b	1.95	0.968	8.30	4.91	7.62	10.65	0.779
28 Pool Girder @ Storage Pool	123054	4021	RB-4	1.25	0.484	0.71	3.00	2.50	4.68	0.151
	123154	7441	RB-9b	1.25	0.484	0.25	0.30	2.50	2.38	0.107
29 Pool Girder @ Cavity	123062	7241	RB-9a	1.24	0.242	0.41	2.60	1.25	3.27	0.127
	123162	7441	RB-9b	1.21	0.242	0.19	0.22	1.21	1.22	0.154
30 Pool Girder @ Fuel Pool	123067	7441	RB-9b	1.28	0.484	1.02	4.00	2.57	5.58	0.182
	123167	7441	RB-9b	1.28	0.484	0.72	1.05	2.56	3.07	0.234
31 MS Tunnel Wall and Slab	150122	7441	RB-9b	1.04	0.177	0.55	1.10	0.76	1.58	0.351
	96611	7241	RB-9a	1.34	0.500	0.50	1.66	2.76	3.75	0.134
	98614	7241	RB-9a	2.14	0.500	0.57	2.34	4.42	5.74	0.100
32 IC/PCCS Pool Wall in NS Direction	125051	7741	RB-9a	0.79	0.250	0.06	0.07	0.81	0.75	0.075
	125151	7441	RB-9b	0.79	0.250	0.10	0.12	0.82	0.80	0.130
	125055	7741	RB-9a	0.80	0.250	0.08	0.09	0.83	0.78	0.100
	125155	7441	RB-9b	0.81	0.250	0.23	2.01	0.83	2.42	0.096



HITACHI

WG3-U71-ERD-S-0004 SH NO. 222

REV. 0

of 538

Table 7.3.2-1 Maximum Stress Ratio of Truss Girder and Column

Member Name : TRUSS R4 upper													
Section ID :		4		Section Type :				H		CBAR ID :		602201	
Flange PL :		600 x 66		Web PL :				468 x 50		i - edge			
Maximum Ratio		Load ID		Design Load (MN,MNm)			Stress (MPa)			Allowable Stress (MPa)			
				P	M	V	fac,fat	fbc,fbt	fv	Fac,Fat	Fbc,Fbt	Fv	
fac/Fac+fbc/Fbc		0.451		5002	-3.67	-2.06		-35.7	-101.2		290.8	364.0	
fat/Fat+fbt/Fbt		0.309		5003	0.88	-2.09		8.5	-103.0		330.9	364.0	
fv/Fv		0.088		8113			-0.51			-17.1		193.1	

Member Name : TRUSS R4 upper													
Section ID :		4		Section Type :				H		CBAR ID :		602206	
Flange PL :		600 x 66		Web PL :				468 x 50		j - edge			
Maximum Ratio		Load ID		Design Load (MN,MNm)			Stress (MPa)			Allowable Stress (MPa)			
				P	M	V	fac,fat	fbc,fbt	fv	Fac,Fat	Fbc,Fbt	Fv	
fac/Fac+fbc/Fbc		0.394		8127	-6.01	0.87		-58.5	42.8		311.8	386.8	
fat/Fat+fbt/Fbt		0.048		8625	0.55	-0.26		5.3	-12.8		351.6	386.8	
fv/Fv		0.005		8113		0.03				0.9		193.1	

Member Name : TRUSS R4 lower													
Section ID :		4		Section Type :				H		CBAR ID :		603201	
Flange PL :		600 x 66		Web PL :				468 x 50		i - edge			
Maximum Ratio		Load ID		Design Load (MN,MNm)			Stress (MPa)			Allowable Stress (MPa)			
				P	M	V	fac,fat	fbc,fbt	fv	Fac,Fat	Fbc,Fbt	Fv	
fac/Fac+fbc/Fbc		0.565		5002	-2.39	-3.04		-23.3	-149.6		262.2	330.9	
fat/Fat+fbt/Fbt		0.482		5001	0.84	-3.08		8.1	-151.3		330.9	330.9	
fv/Fv		0.103		5001		-0.60				-19.9		193.1	

Member Name : TRUSS R4 lower													
Section ID :		4		Section Type :				H		CBAR ID :		603206	
Flange PL :		600 x 66		Web PL :				468 x 50		j - edge			
Maximum Ratio		Load ID		Design Load (MN,MNm)			Stress (MPa)			Allowable Stress (MPa)			
				P	M	V	fac,fat	fbc,fbt	fv	Fac,Fat	Fbc,Fbt	Fv	
fac/Fac+fbc/Fbc		0.353		8624	-6.80	-0.25		-66.3	-12.4		283.9	386.8	
fat/Fat+fbt/Fbt		0.679		5001	18.88	0.91		184.0	44.7		330.9	364.0	
fv/Fv		0.006		5002		-0.03				-1.1		193.1	

Member Name : TRUSS R4 diagonal													
Section ID :		1		Section Type :				H		CBAR ID :		605201	
Flange PL :		600 x 32		Web PL :				536 x 32		i - edge			
Maximum Ratio		Load ID		Design Load (MN,MNm)			Stress (MPa)			Allowable Stress (MPa)			
				P	M	V	fac,fat	fbc,fbt	fv	Fac,Fat	Fbc,Fbt	Fv	
fac/Fac+fbc/Fbc		0.630		8114	-7.24	0.00		-130.4	0.0		295.5	385.3	
fat/Fat+fbt/Fbt		0.131		8625	2.57	0.00		46.2	0.0		351.6	385.3	
fv/Fv		---		---		---				---		---	



HITACHI

WG3-U71-ERD-S-0004 SH NO. 223

REV. 0

of 538

Table 7.3.2-1 Maximum Stress Ratio of Truss Girder and Column (Continued)

Member Name : TRUSS R4 diagonal													
Section ID :		3		Section Type :				H		CBAR ID :		605206	
Flange PL :		400 x 25		Web PL :				350 x 25		j - edge			
Maximum Ratio		Load ID		Design Load (MN,MNm)			Stress (MPa)			Allowable Stress (MPa)			
				P	M	V	fac,fat	fbc,fbt	fv	Fac,Fat	Fbc,Fbt	Fv	
fac/Fac+fbc/Fbc		0.114	8624	-0.68	0.00		-23.6	0.0		272.5	351.6		
fat/Fat+fbt/Fbt		0.165	5001	1.57	0.00		54.5	0.0		330.9	330.9		
fv/Fv		---	---			---			---			---	

Member Name : TRUSS R4 post													
Section ID :		5		Section Type :				2L		CBAR ID :		604204	
Flange PL :		203 x 22		Web PL :				159 x 22		i - edge			
Maximum Ratio		Load ID		Design Load (MN,MNm)			Stress (MPa)			Allowable Stress (MPa)			
				P	M	V	fac,fat	fbc,fbt	fv	Fac,Fat	Fbc,Fbt	Fv	
fac/Fac+fbc/Fbc		0.655	8113	-2.29	0.00		-135.6	0.0		330.6	386.8		
fat/Fat+fbt/Fbt		0.166	8624	0.99	0.00		58.5	0.0		351.6	386.8		
fv/Fv		---	---			---			---			---	

Member Name : R4-RB column													
Section ID :		60		Section Type :				H		CBAR ID :		600201	
Flange PL :		800 x 88		Web PL :				624 x 75		i - edge			
Maximum Ratio		Load ID		Design Load (MN,MNm)			Stress (MPa)			Allowable Stress (MPa)			
				P	M	V	fac,fat	fbc,fbt	fv	Fac,Fat	Fbc,Fbt	Fv	
fac/Fac+fbc/Fbc		0.623	8114	-19.61	2.02		-104.5	41.5		327.2	351.6		
fat/Fat+fbt/Fbt		0.058	8615	0.59	-0.84		3.2	-17.3		351.6	351.6		
fv/Fv		0.025	8123			0.29			4.9			193.1	

Member Name : R4-RB column													
Section ID :		6		Section Type :				H		CBAR ID :		600209	
Flange PL :		800 x 88		Web PL :				624 x 50		j - edge			
Maximum Ratio		Load ID		Design Load (MN,MNm)			Stress (MPa)			Allowable Stress (MPa)			
				P	M	V	fac,fat	fbc,fbt	fv	Fac,Fat	Fbc,Fbt	Fv	
fac/Fac+fbc/Fbc		0.627	5002	-11.61	-4.71		-67.5	-99.3		306.9	330.9		
fat/Fat+fbt/Fbt		0.067	8625	0.81	0.90		4.7	19.0		351.6	351.6		
fv/Fv		0.077	5002			0.60			14.9			193.1	

Member Name : R4-RF column													
Section ID :		60		Section Type :				H		CBAR ID :		601201	
Flange PL :		800 x 88		Web PL :				624 x 75		i - edge			
Maximum Ratio		Load ID		Design Load (MN,MNm)			Stress (MPa)			Allowable Stress (MPa)			
				P	M	V	fac,fat	fbc,fbt	fv	Fac,Fat	Fbc,Fbt	Fv	
fac/Fac+fbc/Fbc		0.895	8114	-26.63	-3.57		-142.0	-73.4		327.2	351.6		
fat/Fat+fbt/Fbt		0.101	5503	4.26	0.52		22.7	10.7		330.9	330.9		
fv/Fv		0.067	8127			-0.78			-13.0			193.1	

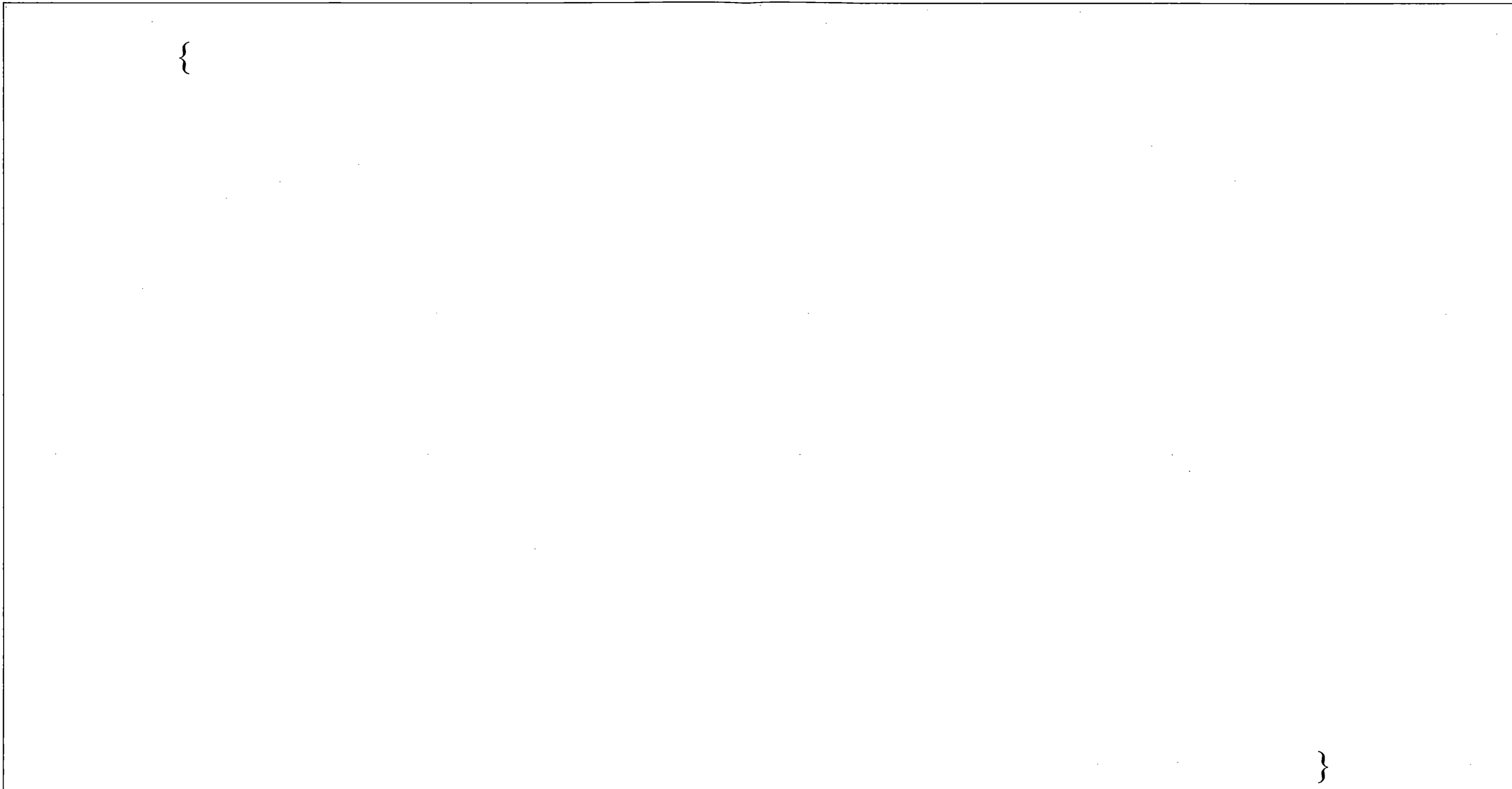


Figure 3.1-1 RB and FB Concrete Outline Plan at EL -11,500

{{{Contains Security-Related Information – Withheld Under 10 CFR 2.390.}}}

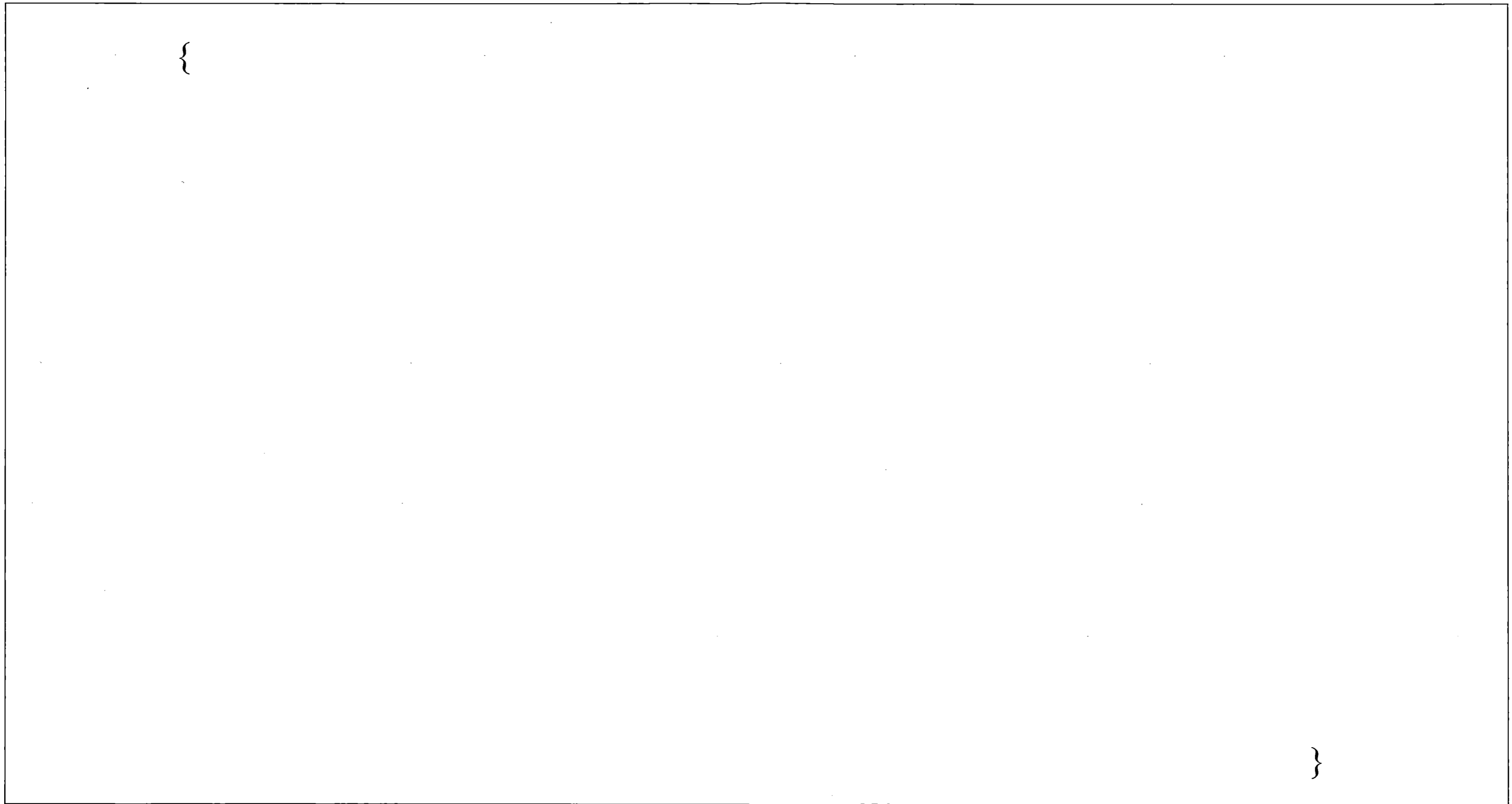


Figure 3.1-2 RB and FB Concrete Outline Plan at EL 4,650

{{{Contains Security-Related Information – Withheld Under 10 CFR 2.390.}}}



HITACHI

WG3-U71-ERD-S-0004 SH NO. 226
REV. 0 of 538

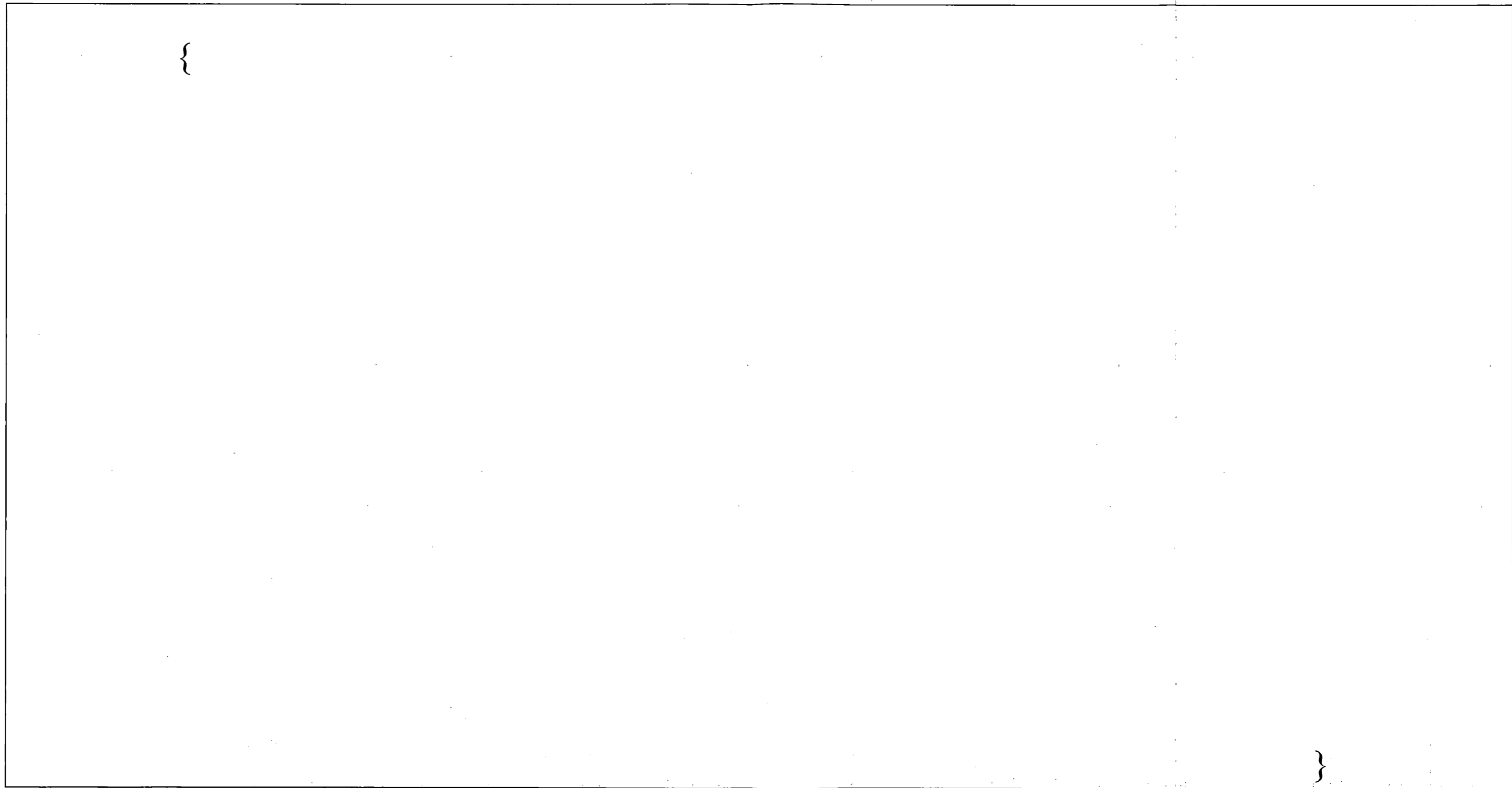


Figure 3.1-3 RB and FB Concrete Outline Plan at EL 17,500

{{{Contains Security-Related Information – Withheld Under 10 CFR 2.390.}}}

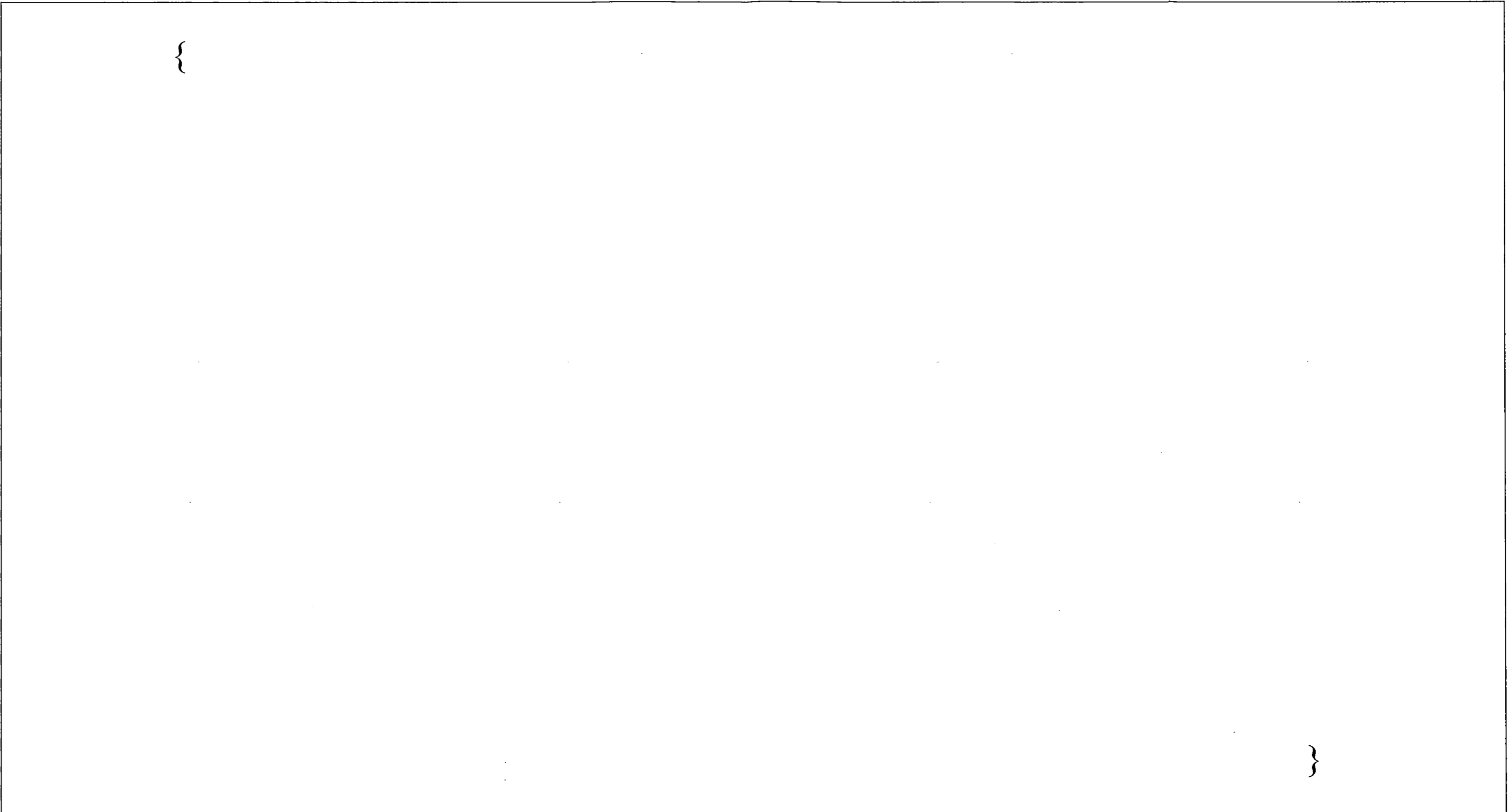


Figure 3.1-4 RB and FB Concrete Outline Plan at EL 27,000

{{{Contains Security-Related Information – Withheld Under 10 CFR 2.390.}}}

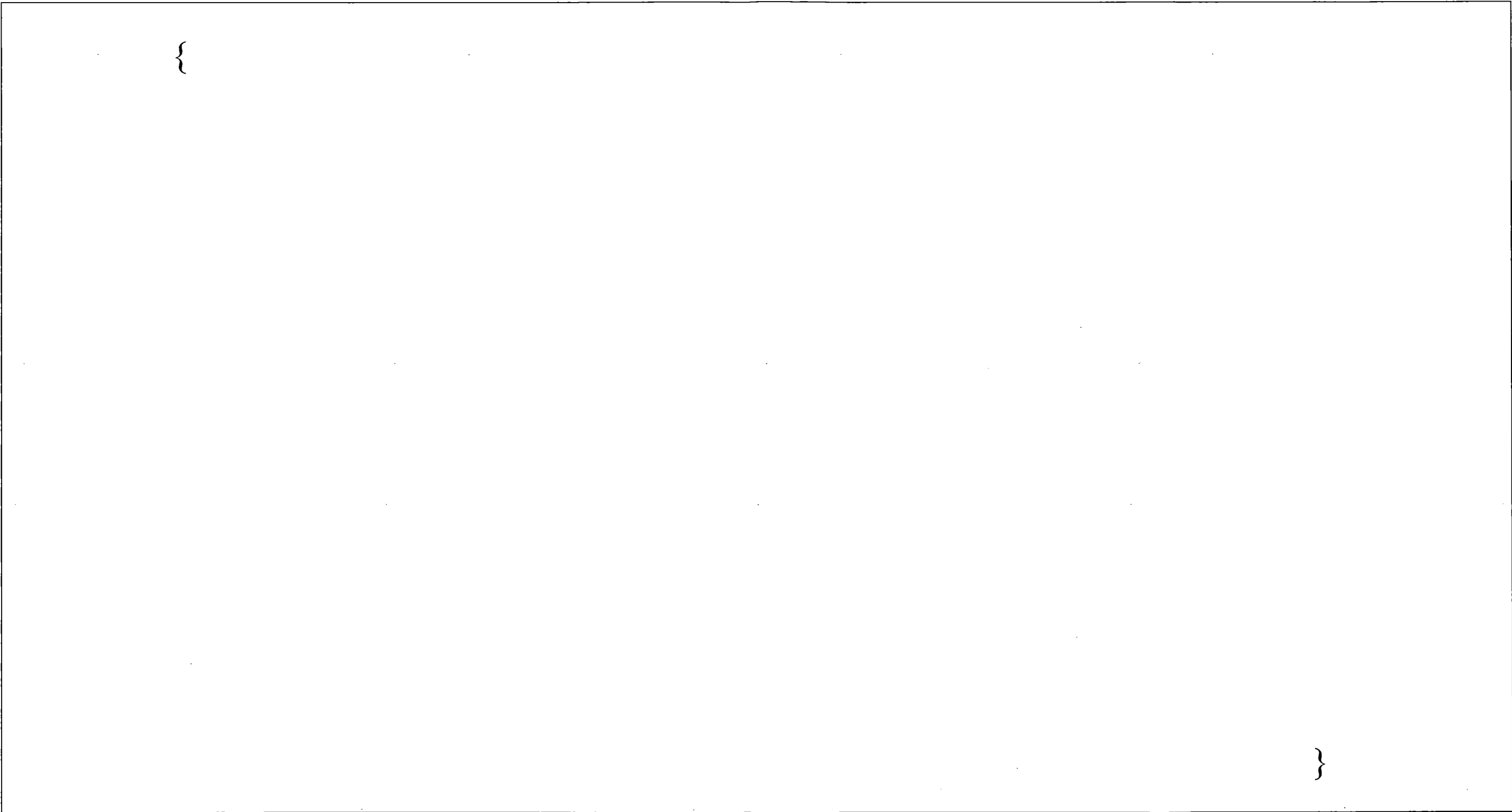


Figure 3.1-5 RB Concrete Outline Plan at EL 34,000

{{{Contains Security-Related Information – Withheld Under 10 CFR 2.390.}}}

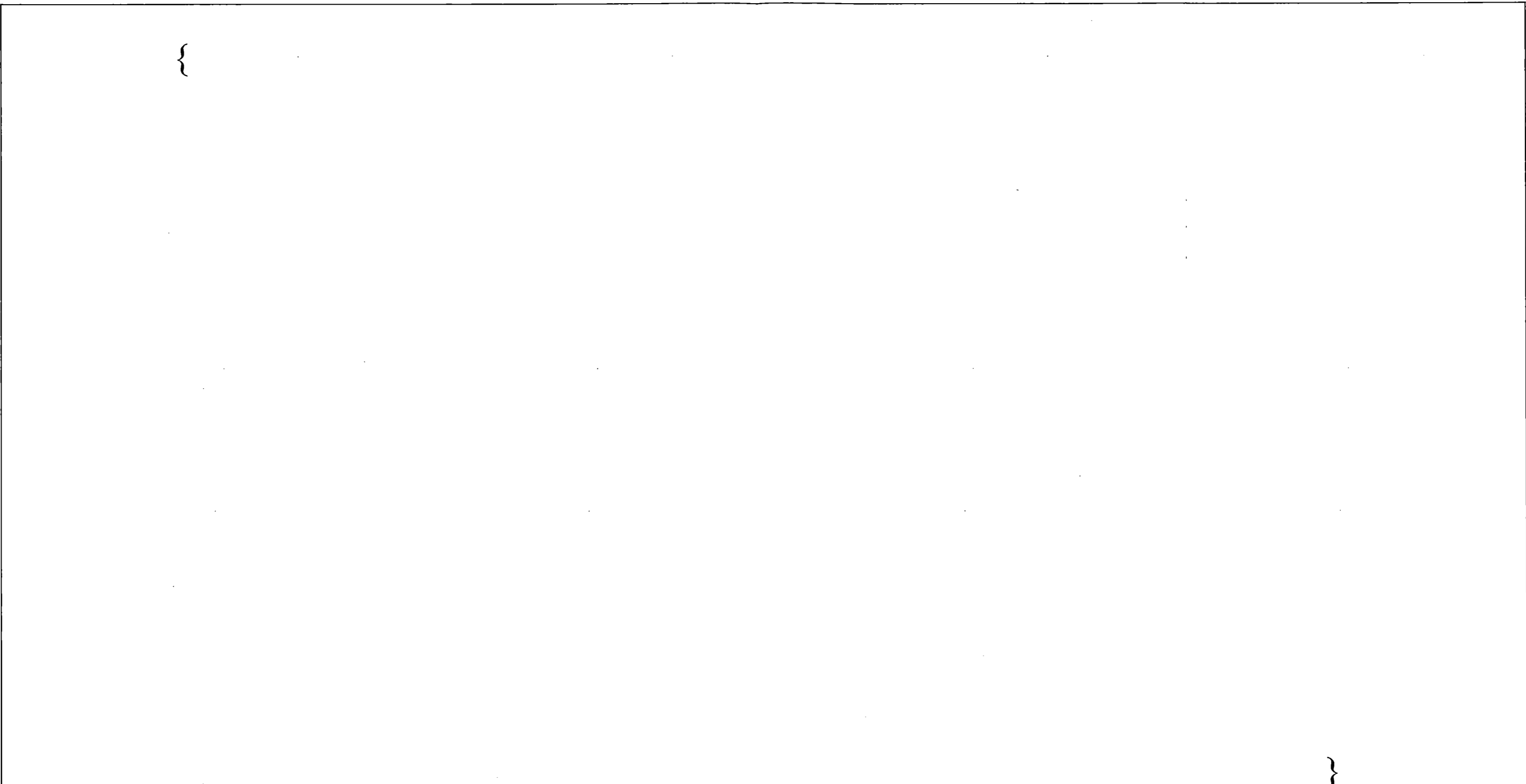


Figure 3.1-6 RB and FB Concrete Outline N-S Section

{{{Contains Security-Related Information – Withheld Under 10 CFR 2.390.}}}



HITACHI

WG3-U71-ERD-S-0004 SH NO. 230
REV. 0 of 538

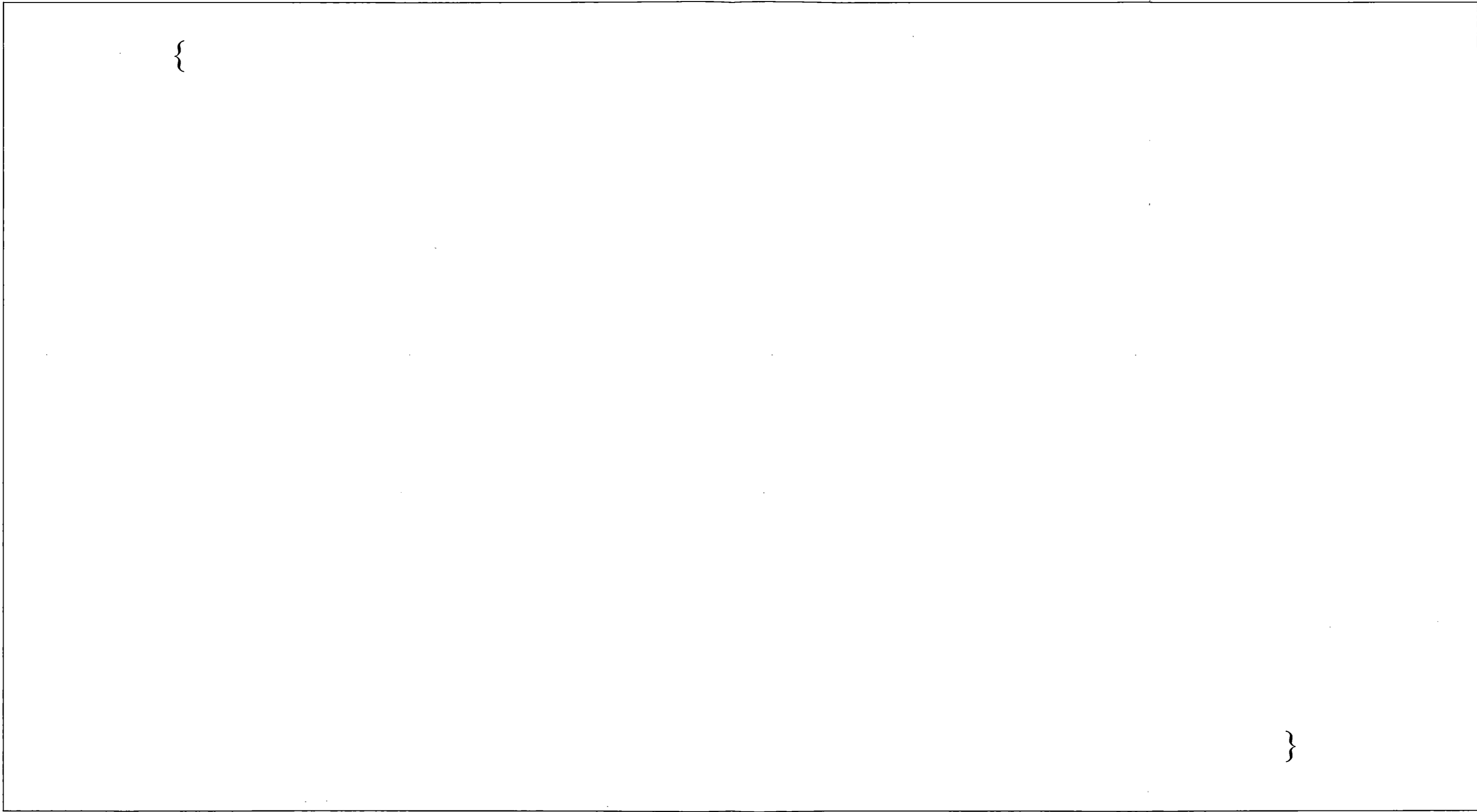


Figure 3.1-7 RB and FB Concrete Outline E-W Section
{{{Contains Security-Related Information – Withheld Under 10 CFR 2.390.}}}

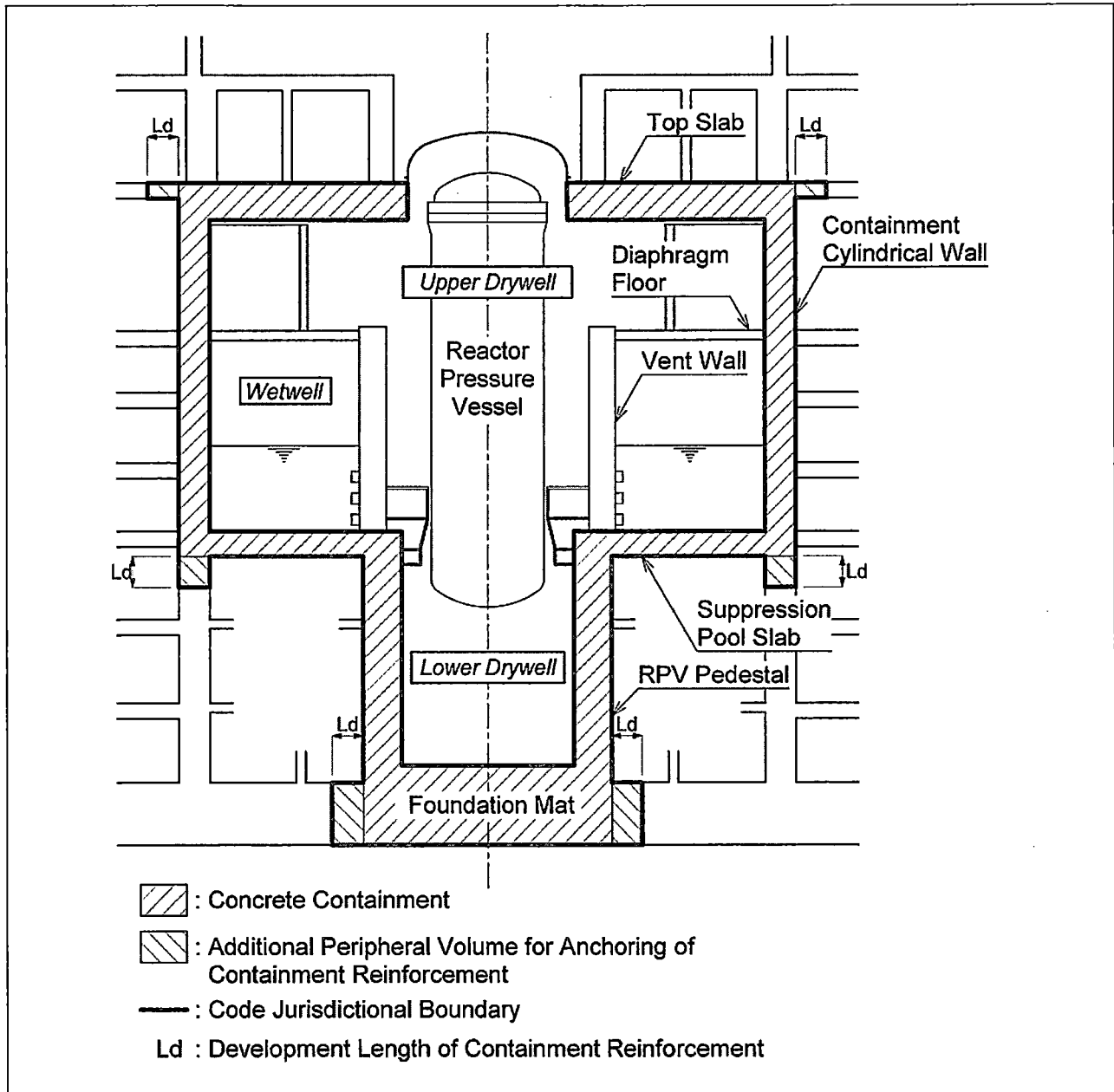


Figure 3.2-1 Configuration of RCCV



HITACHI

WG3-U71-ERD-S-0004

SH NO. 232

REV. 0

of 538

{

Figure 3.2-2 Locations of Various Pools in RB and FB

}

{{{Contains Security-Related Information – Withheld Under 10 CFR 2.390.}}}



HITACHI

WG3-U71-ERD-S-0004 SH NO. 233

REV. 0

of 538

{

}

Figure 5.1.1-1 Regions for Equipment Loads at EL -11,500

{{{Contains Security-Related Information – Withheld Under 10 CFR 2.390.}}}



HITACHI

WG3-U71-ERD-S-0004 SH NO. 234

REV. 0

of 538

{

}

Figure 5.1.1-2 Regions for Equipment Loads at EL -6,400

{{{Contains Security-Related Information – Withheld Under 10 CFR 2.390.}}}



HITACHI

WG3-U71-ERD-S-0004 SH NO. 235

REV. 0

of 538

{

Figure 5.1.1-3 Regions for Equipment Loads at EL -1,000

}

{{{Contains Security-Related Information – Withheld Under 10 CFR 2.390.}}}



HITACHI

WG3-U71-ERD-S-0004 SH NO. 236
REV. 0 of 538

{

Figure 5.1.1-4 Regions for Equipment Loads at EL 4,650

}

Contains Security-Related Information – Withheld Under 10 CFR 2.390.



HITACHI

WG3-U71-ERD-S-0004 SH NO. 237

REV. 0

of 538

{

}

Figure 5.1.1-5 Regions for Equipment Loads at EL 9,060

{{{Contains Security-Related Information – Withheld Under 10 CFR 2.390.}}}



HITACHI

WG3-U71-ERD-S-0004 SH NO. 238

REV. 0

of 538

{

}

Figure 5.1.1-6 Regions for Equipment Loads at EL 13,570

{{{Contains Security-Related Information – Withheld Under 10 CFR 2.390.}}}



HITACHI

WG3-U71-ERD-S-0004 SH NO. 239

REV. 0

of 538

{

}

Figure 5.1.1-7 Regions for Equipment Loads at EL 22,500

{{{Contains Security-Related Information – Withheld Under 10 CFR 2.390.}}}



HITACHI

WG3-U71-ERD-S-0004 SH NO. 240

REV. 0

of 538

{

}

Figure 5.1.1-8 Regions for Equipment Loads at EL 27,000

{{{Contains Security-Related Information – Withheld Under 10 CFR 2.390.}}}



HITACHI

WG3-U71-ERD-S-0004 SH NO. 241

REV. 0

of 538

{

}

Figure 5.1.1-9 Regions for Equipment Loads at/above EL 34,000

{{{Contains Security-Related Information – Withheld Under 10 CFR 2.390.}}}

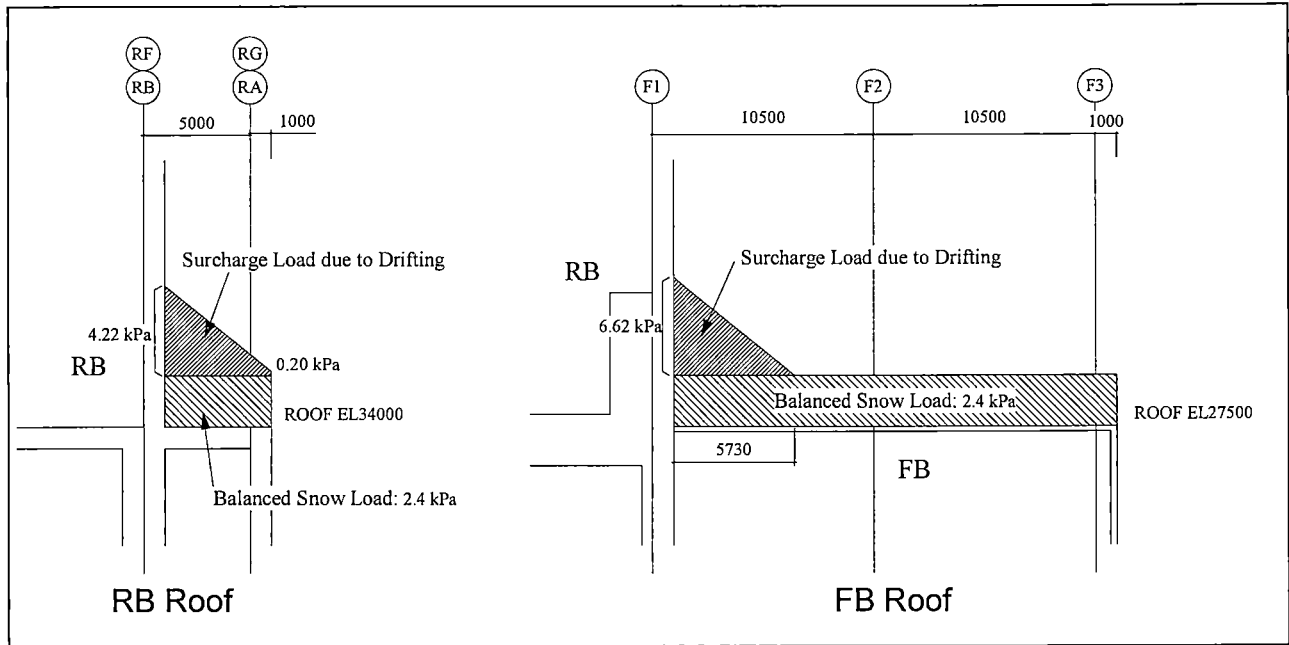


Figure 5.1.2-1 Snow Load

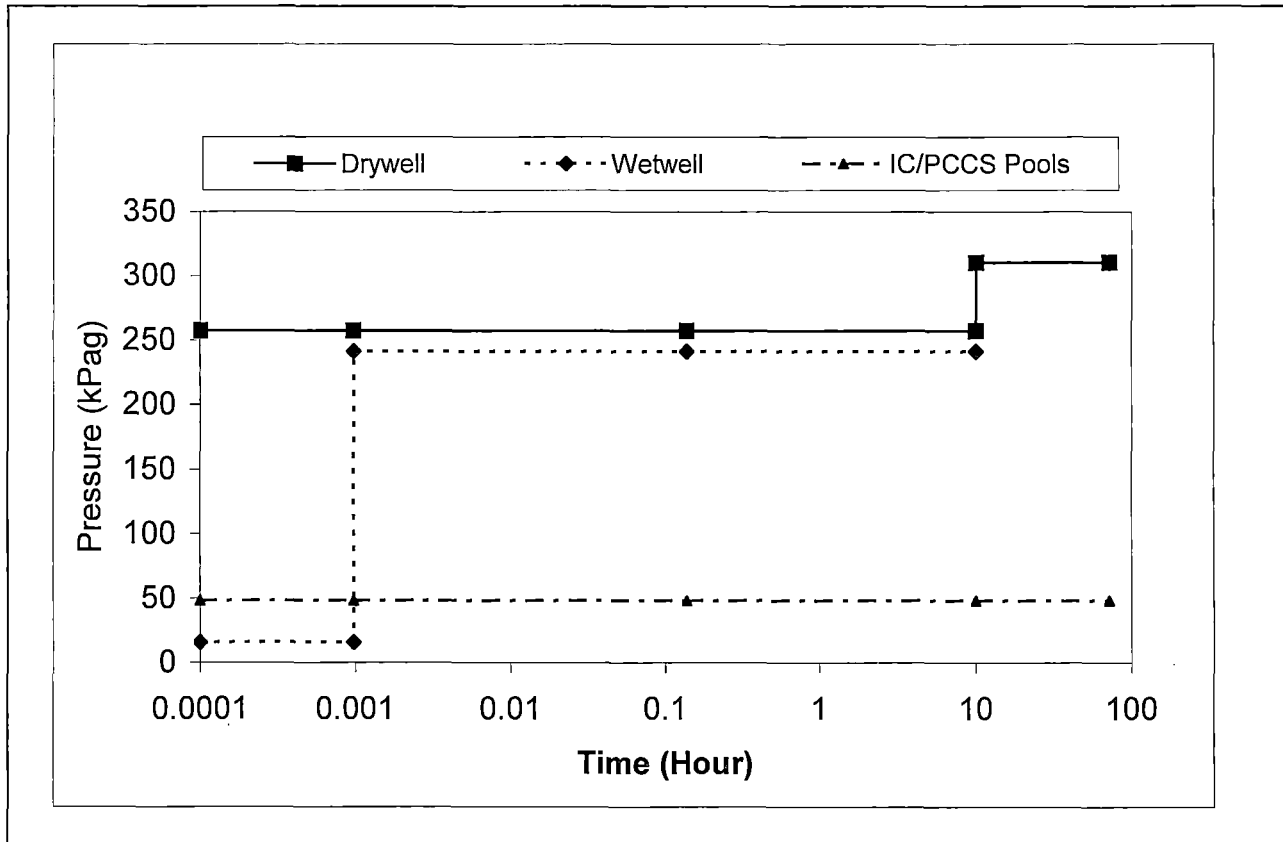


Figure 5.2.1-1 Envelopes of Transient Pressure Curves at DBA

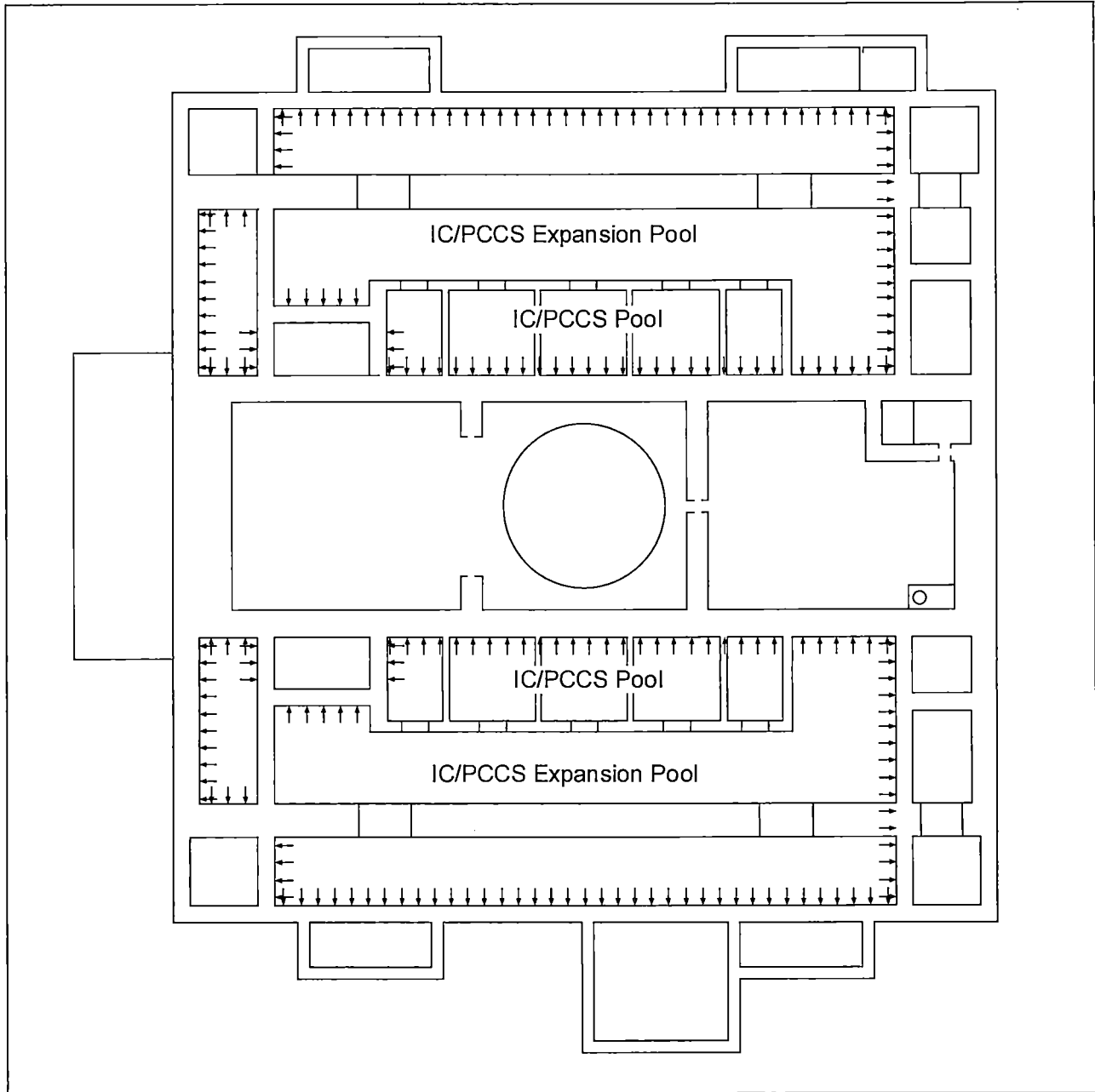


Figure 5.2.1-2 Regions Where Pressure Loads are Applied in IC/PCCS Pools

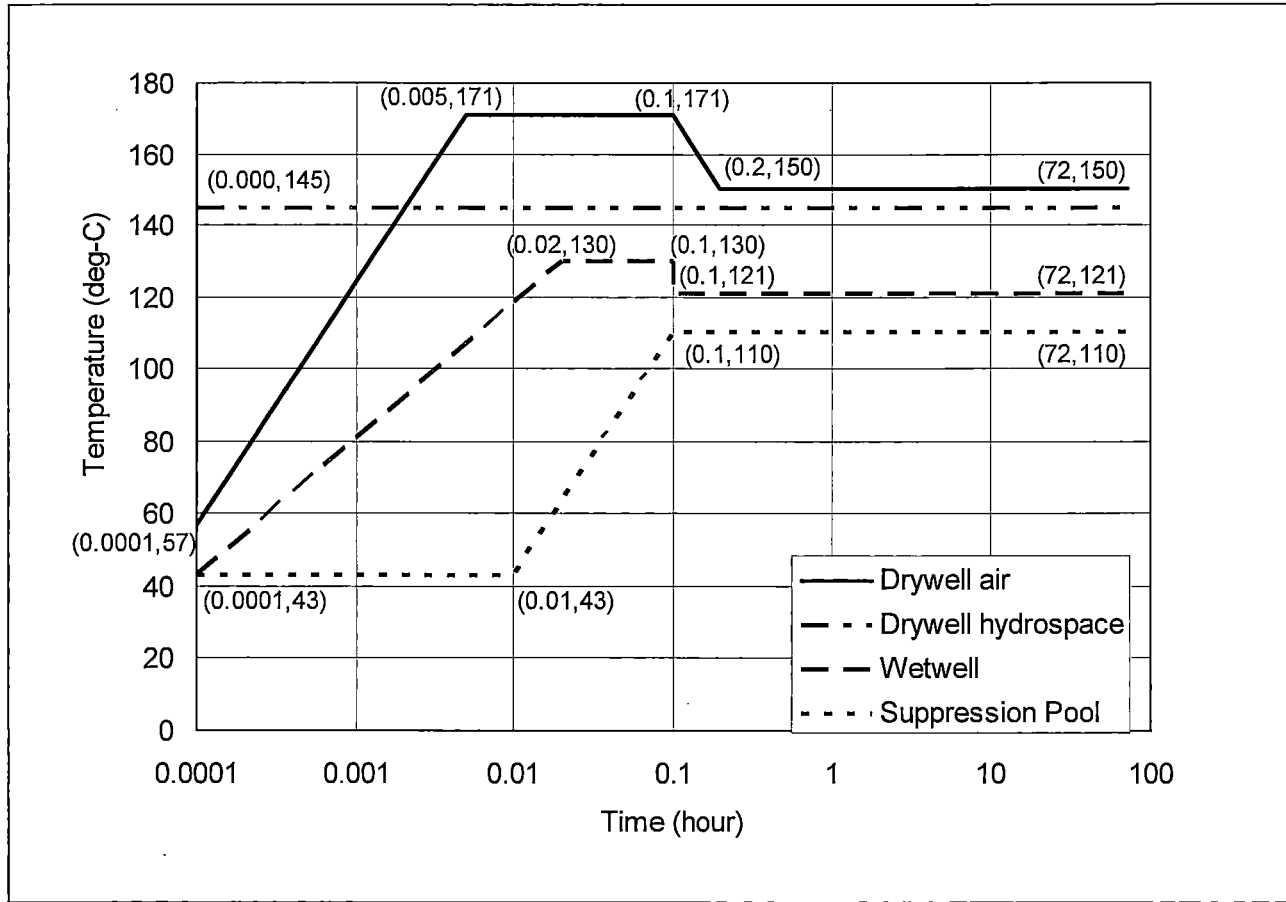


Figure 5.2.2-1 Envelopes of Transient Temperature Curves - Inside RCCV at DBA

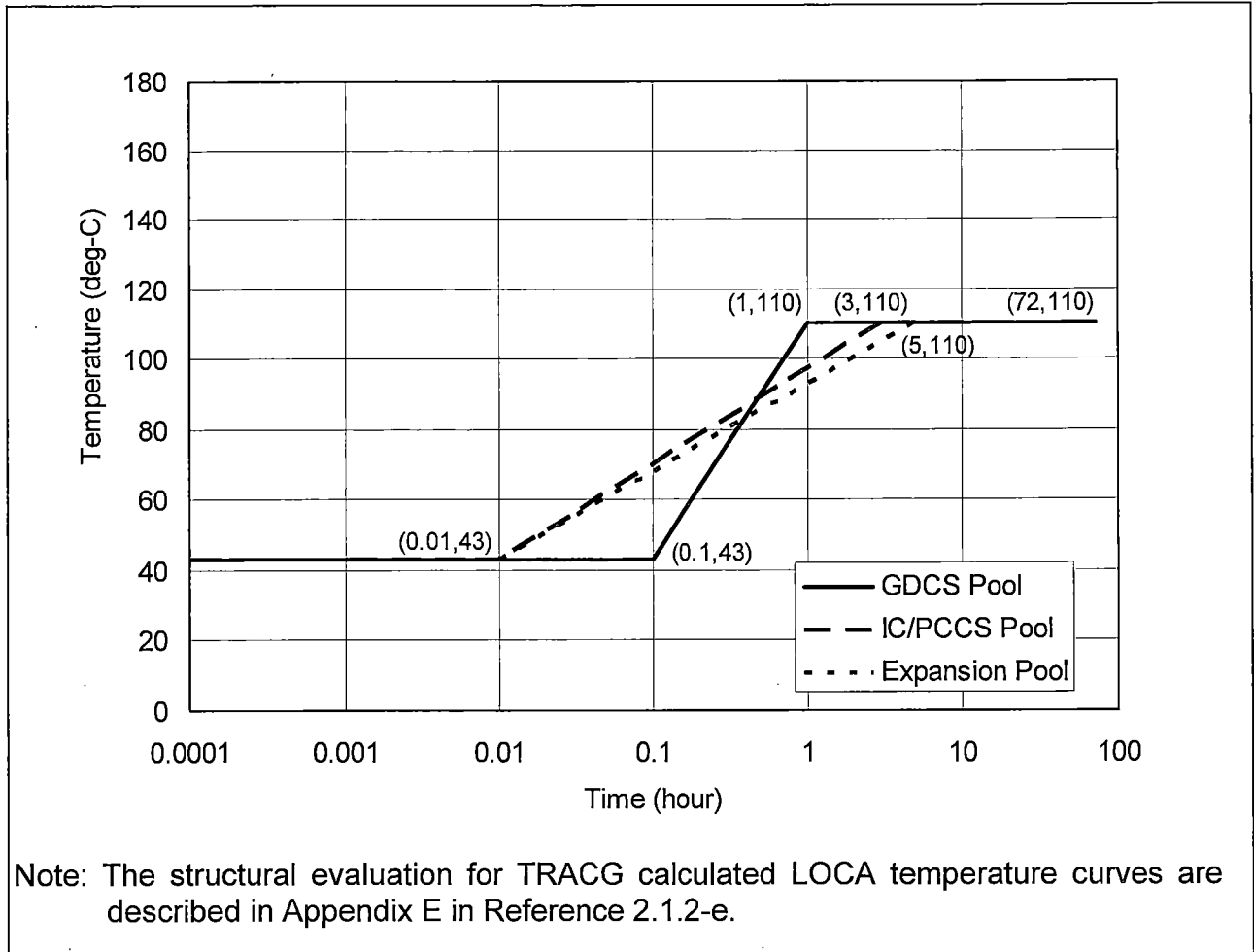


Figure 5.2.2-2 Envelopes of Transient Temperature Curves – Other Pools at DBA

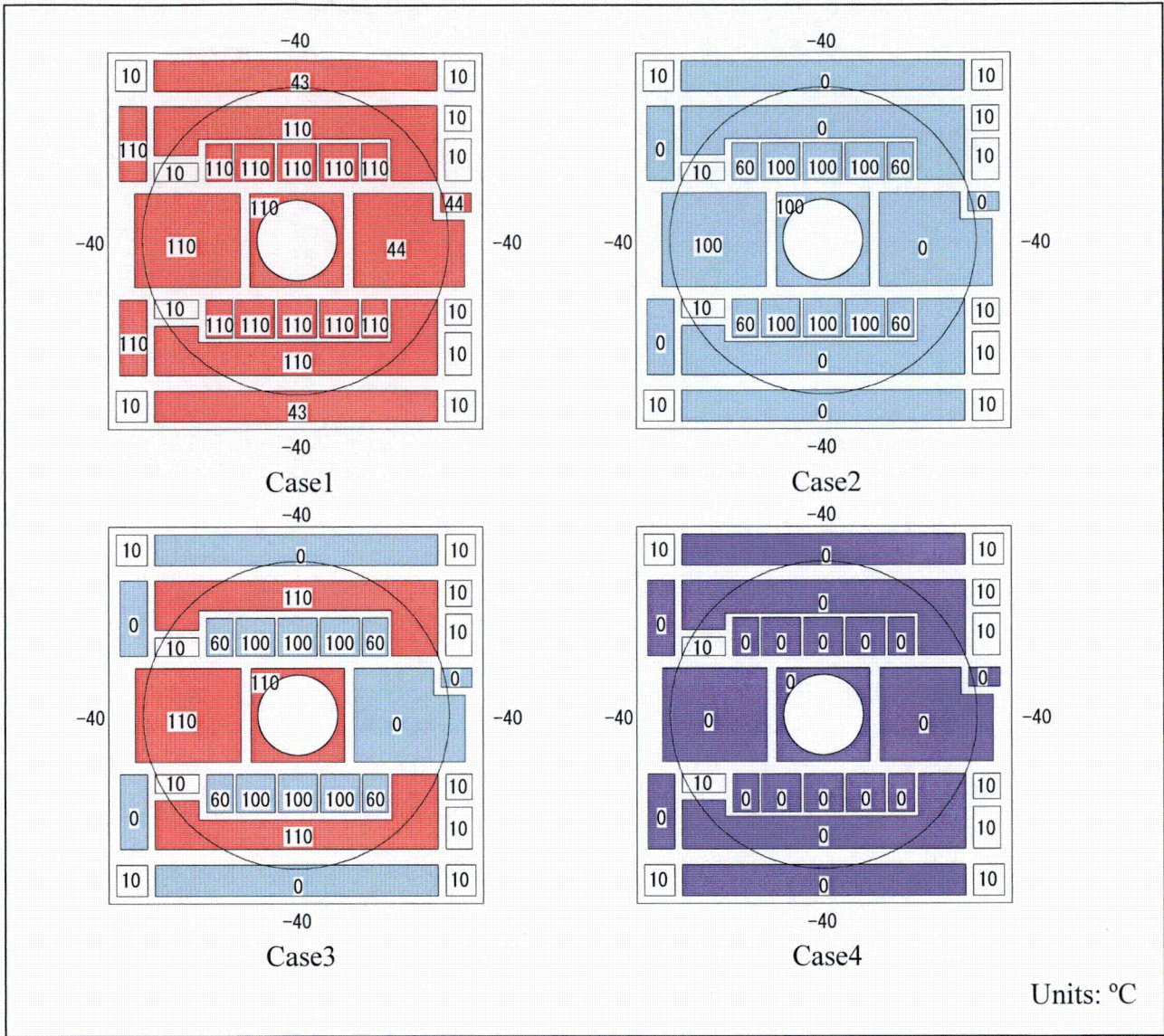


Figure 5.2.2-3 Temperature Distributions in Upper Pools

Units: °C

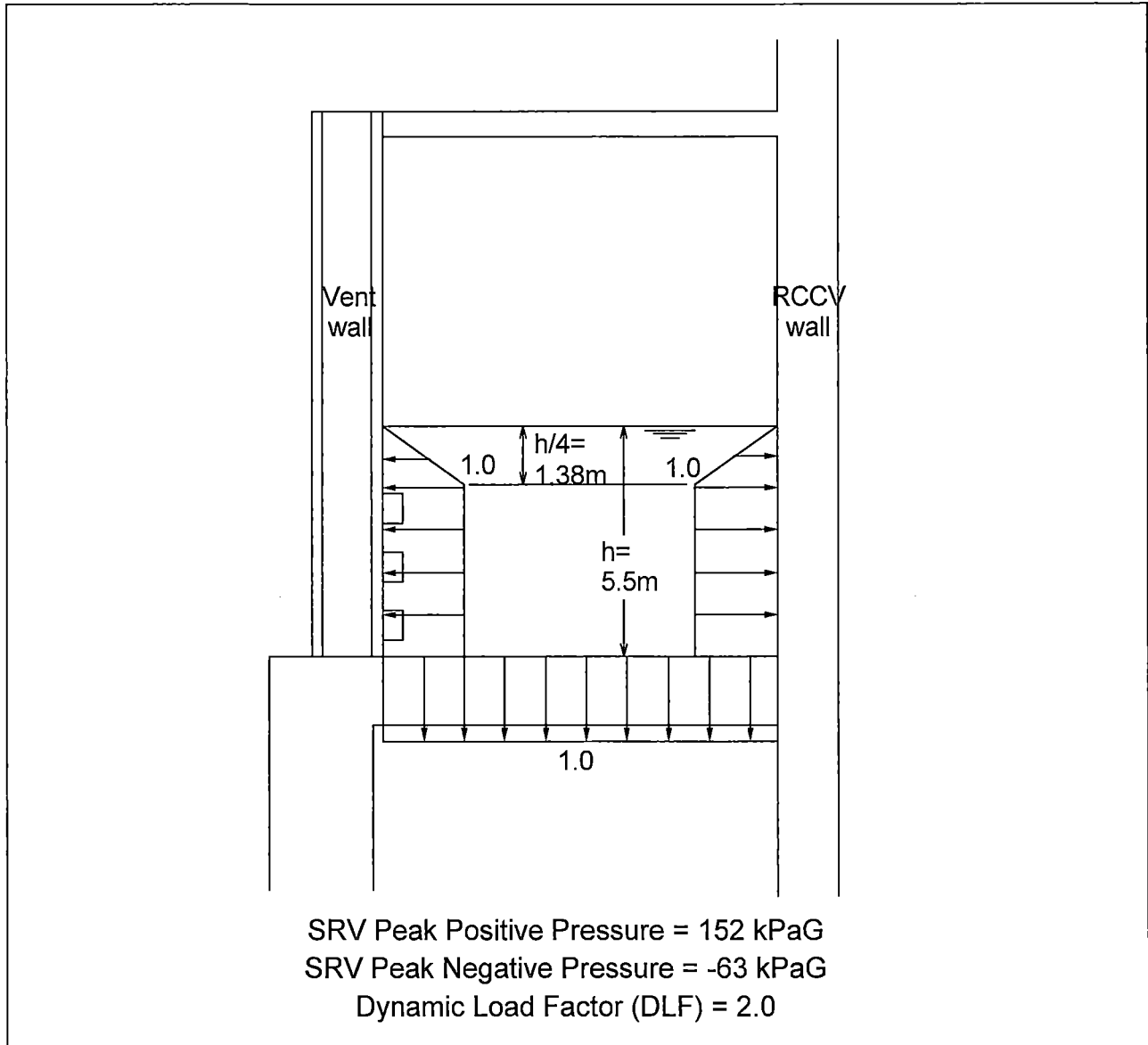


Figure 5.2.3-1 Safety Relief Valve (SRV) Pressure Loads

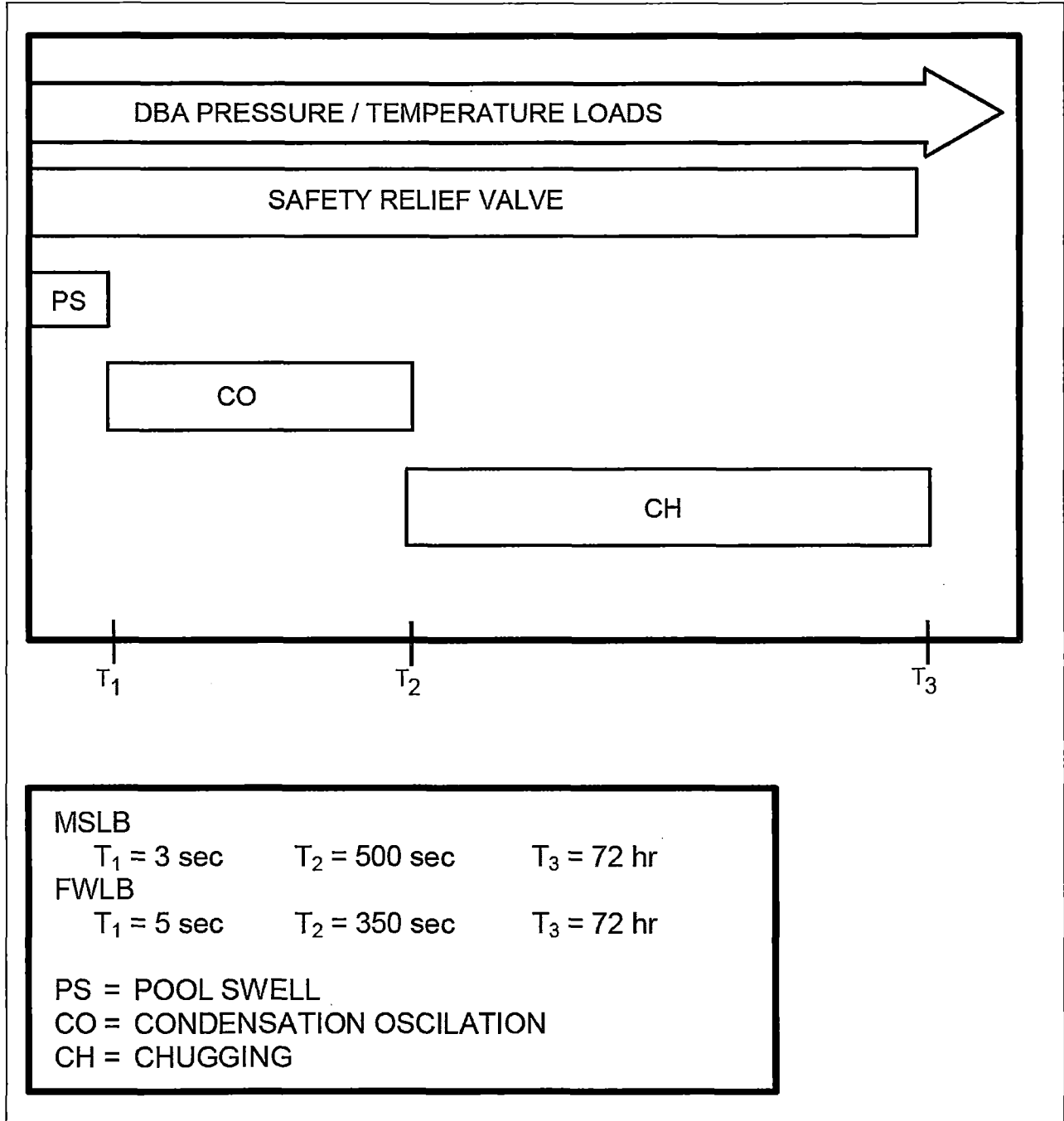


Figure 5.2.3-2 Typical Event – Time Relationship for a DBA

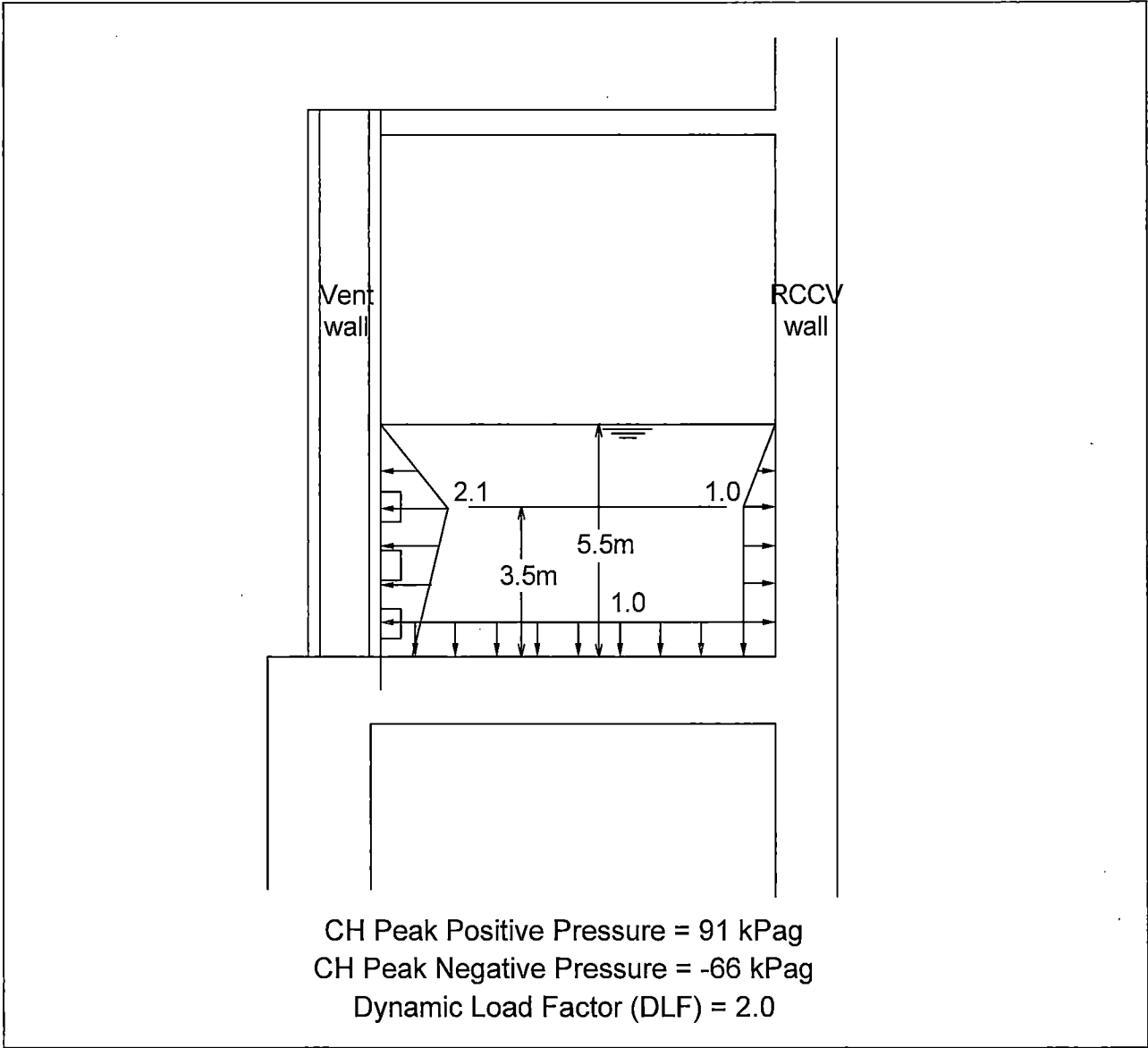


Figure 5.2.3-3 Chugging (CH) Pressure Loads

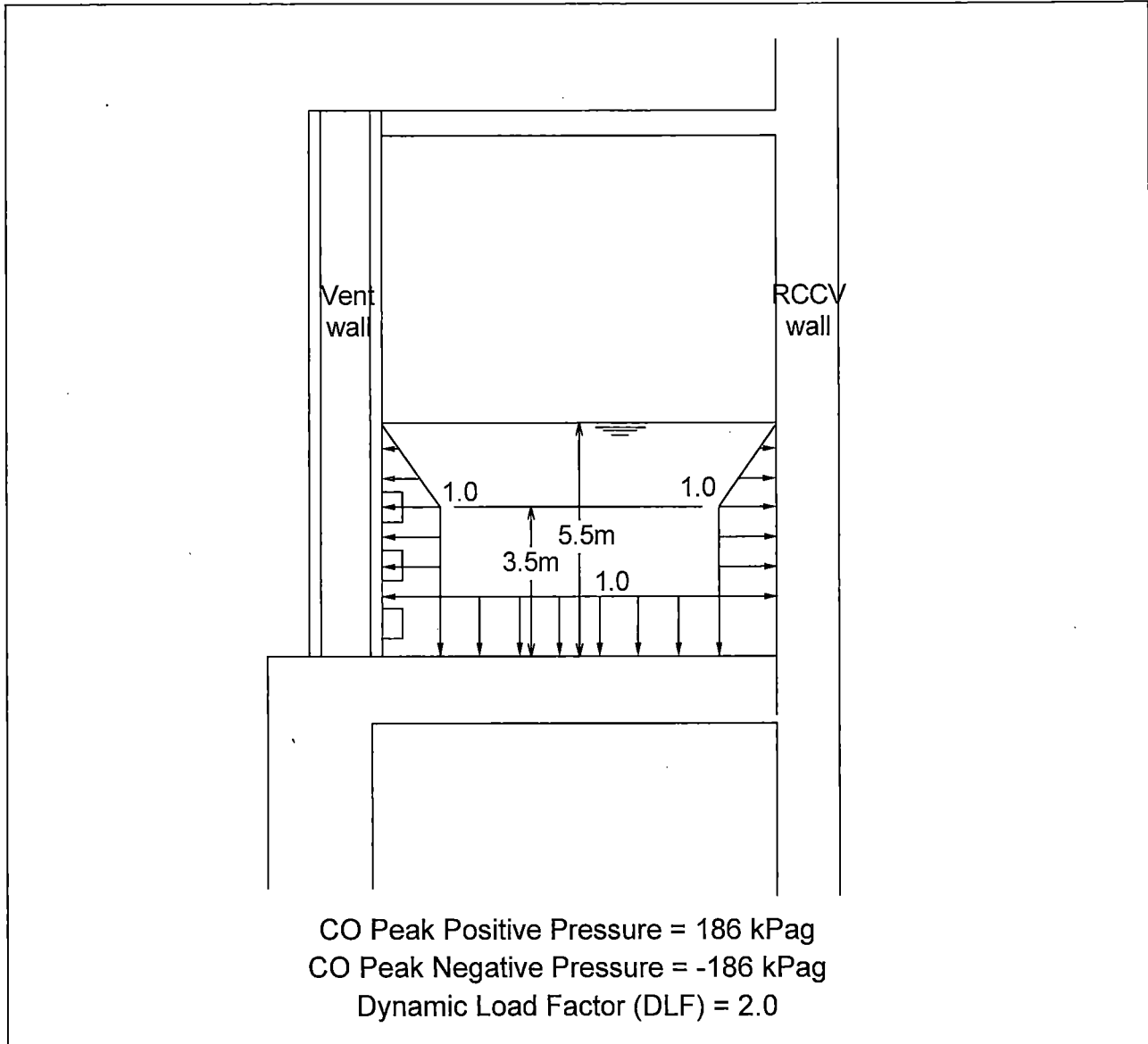
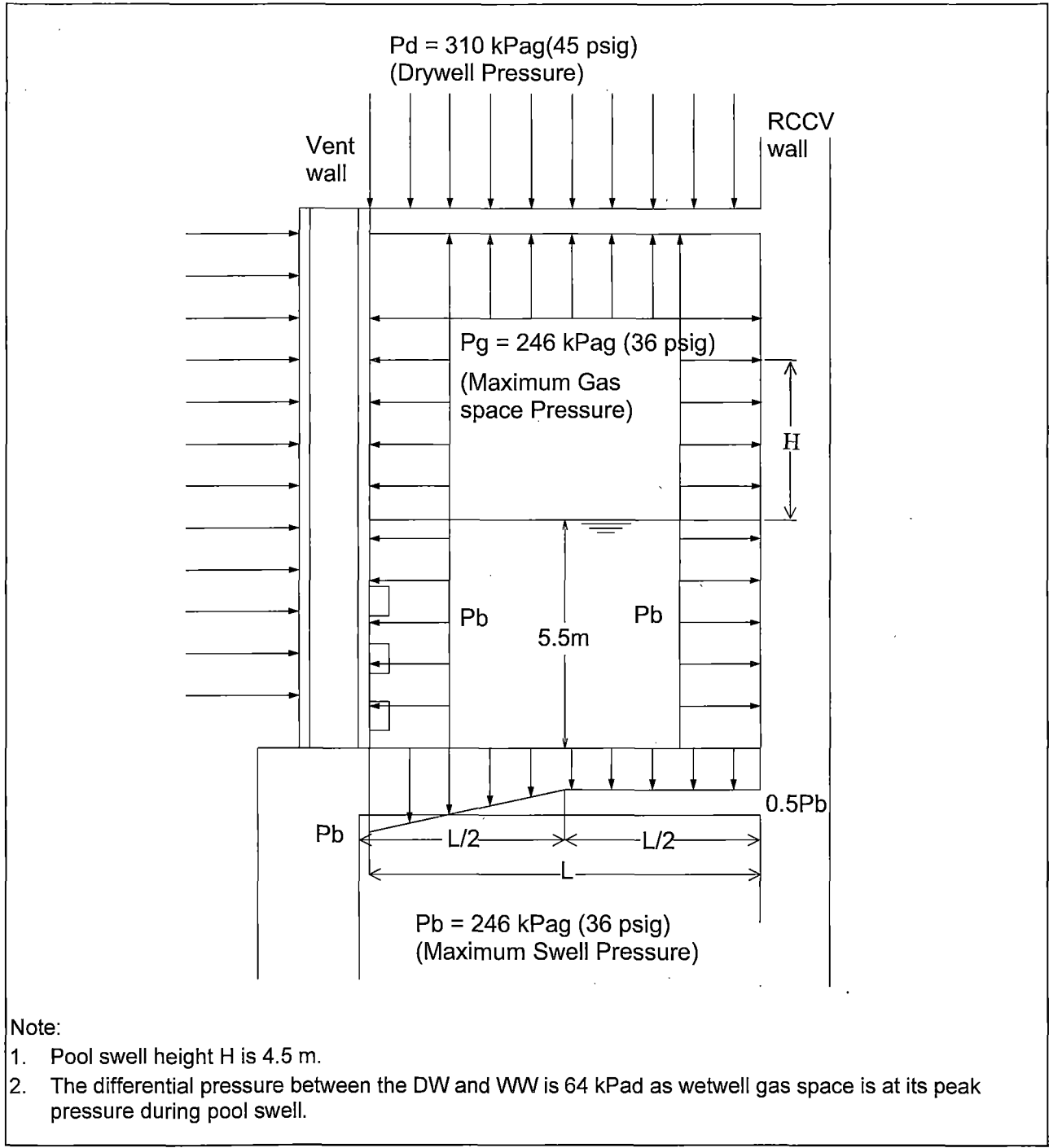


Figure 5.2.3-4 Condensation Oscillation (CO) Pressure Loads



Note:

1. Pool swell height H is 4.5 m.
2. The differential pressure between the DW and WW is 64 kPag as wetwell gas space is at its peak pressure during pool swell.

Figure 5.2.3-5 Pool Swell (PS) Pressure Loads

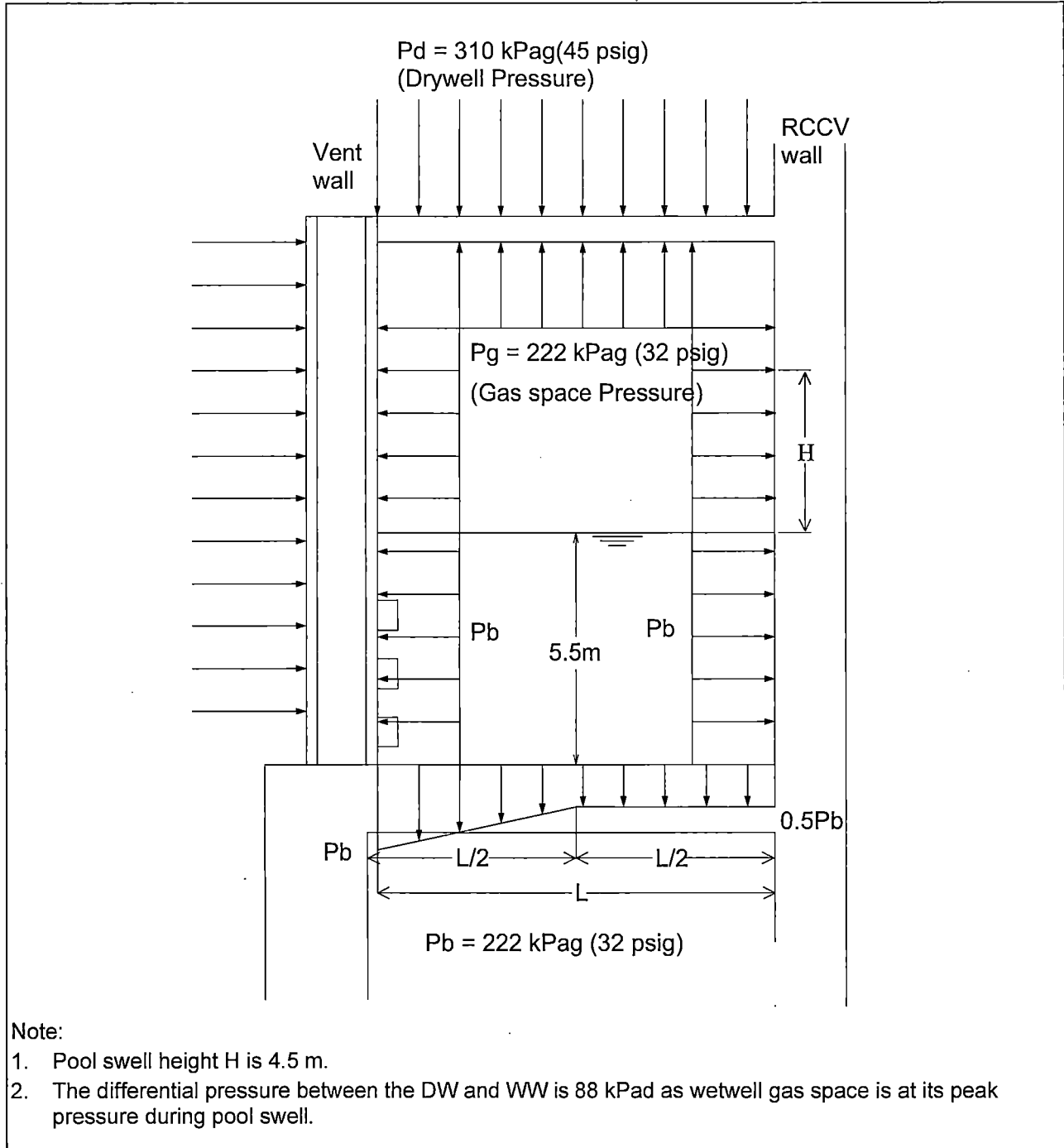


Figure 5.2.3-6 Pool Swell (PS) Pressure Concurrent with Froth Impact Loads

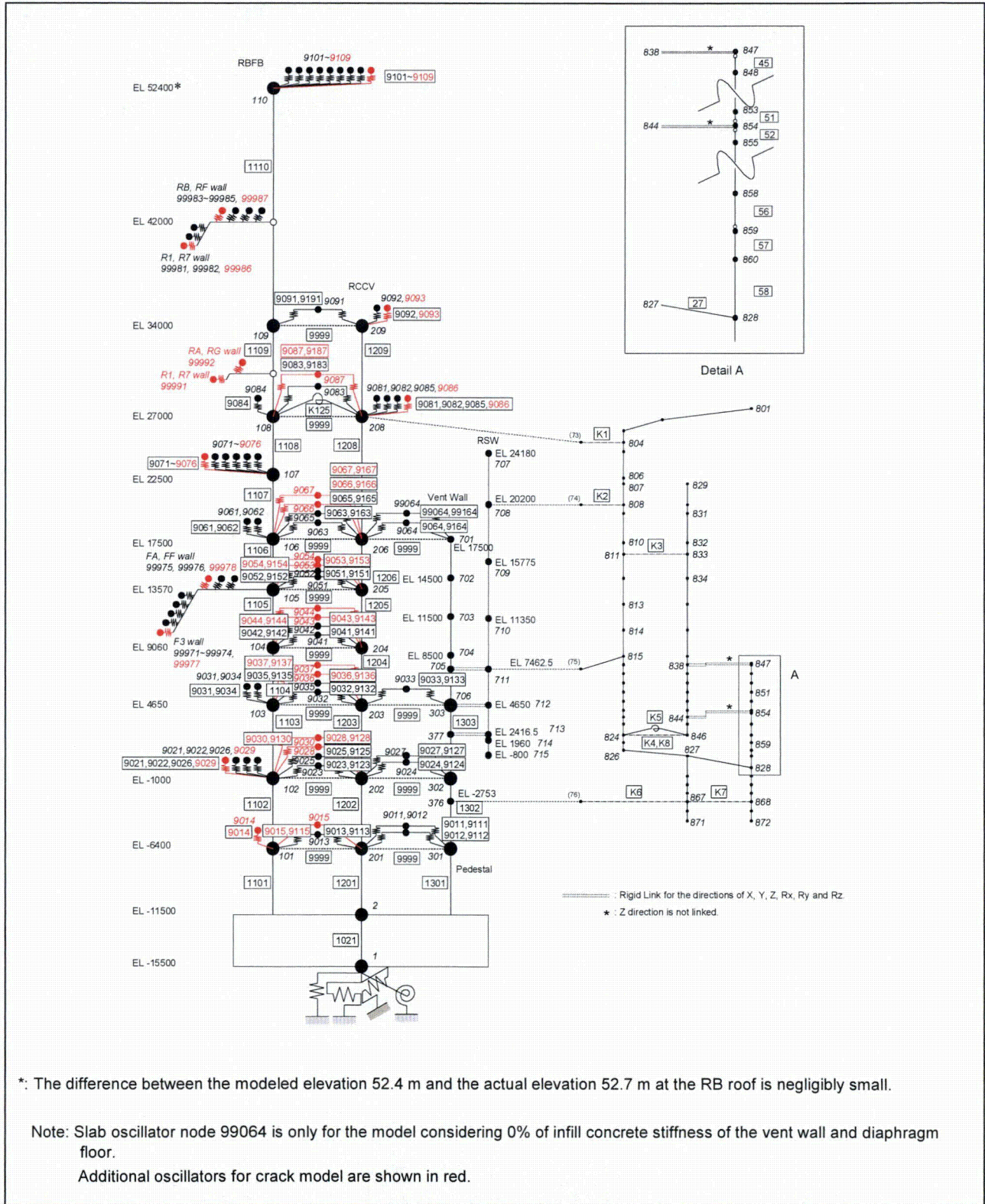


Figure 5.3.3-1 Dynamic Analysis Model

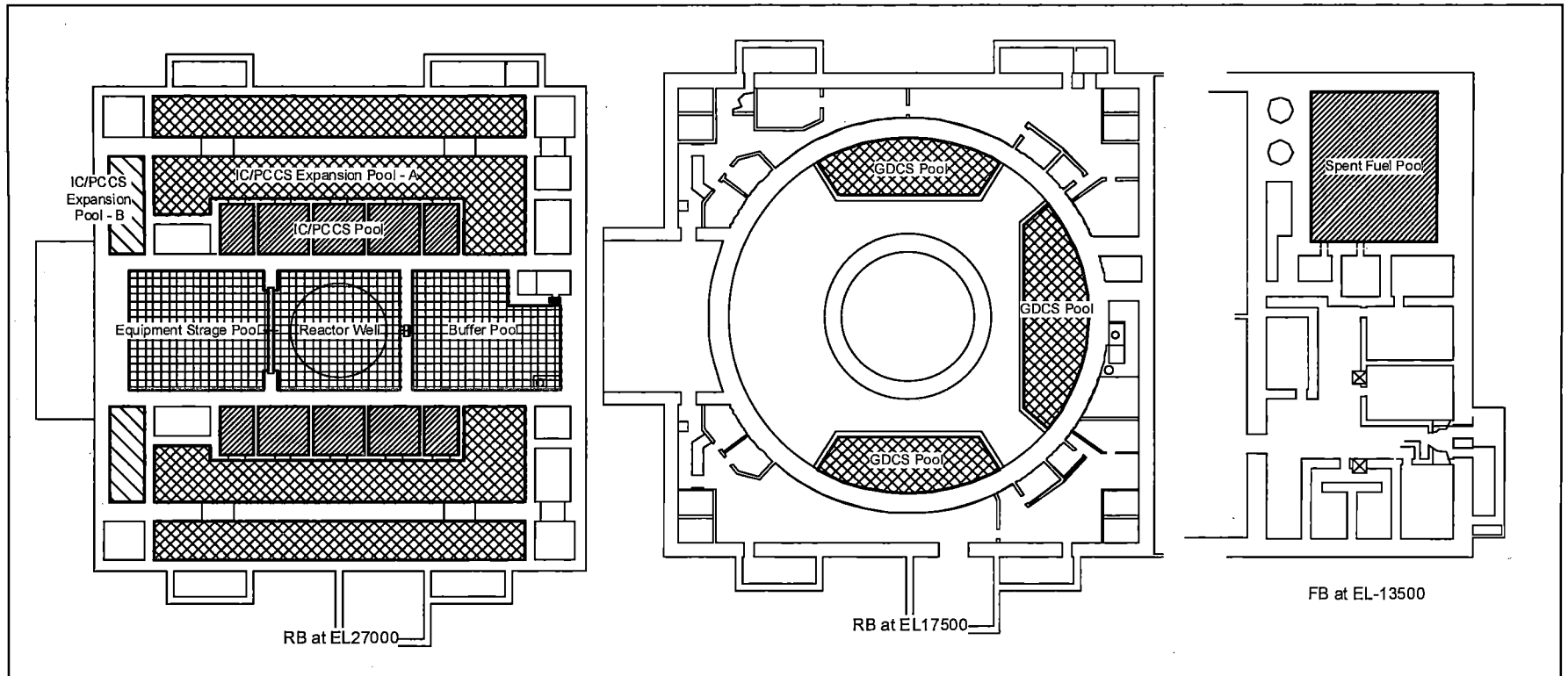


Figure 5.3.3-2 Position of Each Pool



HITACHI

WG3-U71-ERD-S-0004 SH NO. 256

REV. 0

of 538

{

}

Figure 6.2.2-1 FE Model of RB/FB (Whole View)

{{{Contains Security-Related Information – Withheld Under 10 CFR 2.390.}}}



HITACHI

WG3-U71-ERD-S-0004	SH NO. 257
REV. 0	of 538

{

}

Figure 6.2.2-2 FE Model of RB/FB (Cut View)

{{{Contains Security-Related Information – Withheld Under 10 CFR 2.390.}}}

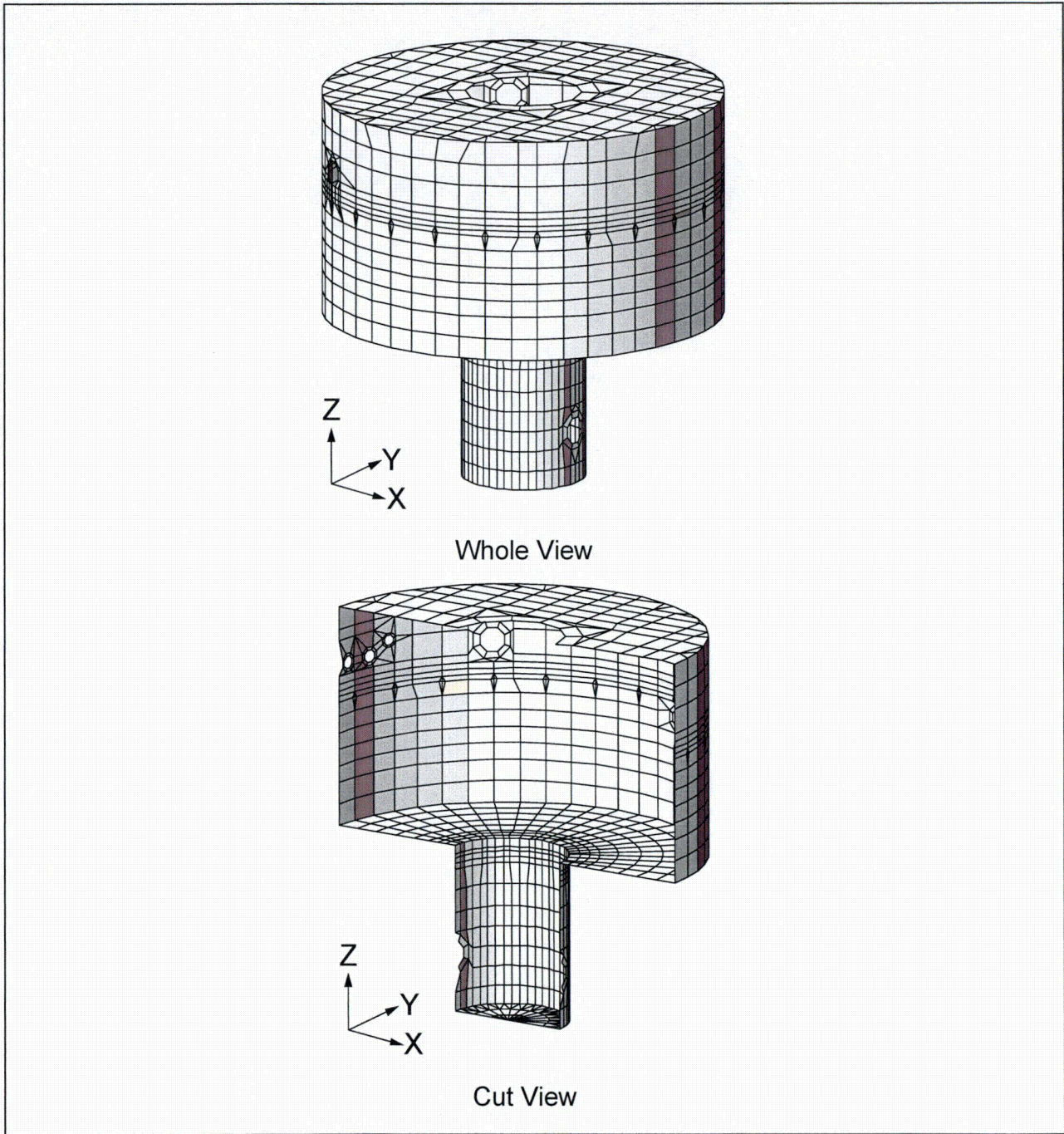


Figure 6.2.2-3 FE Model of RCCV Liner

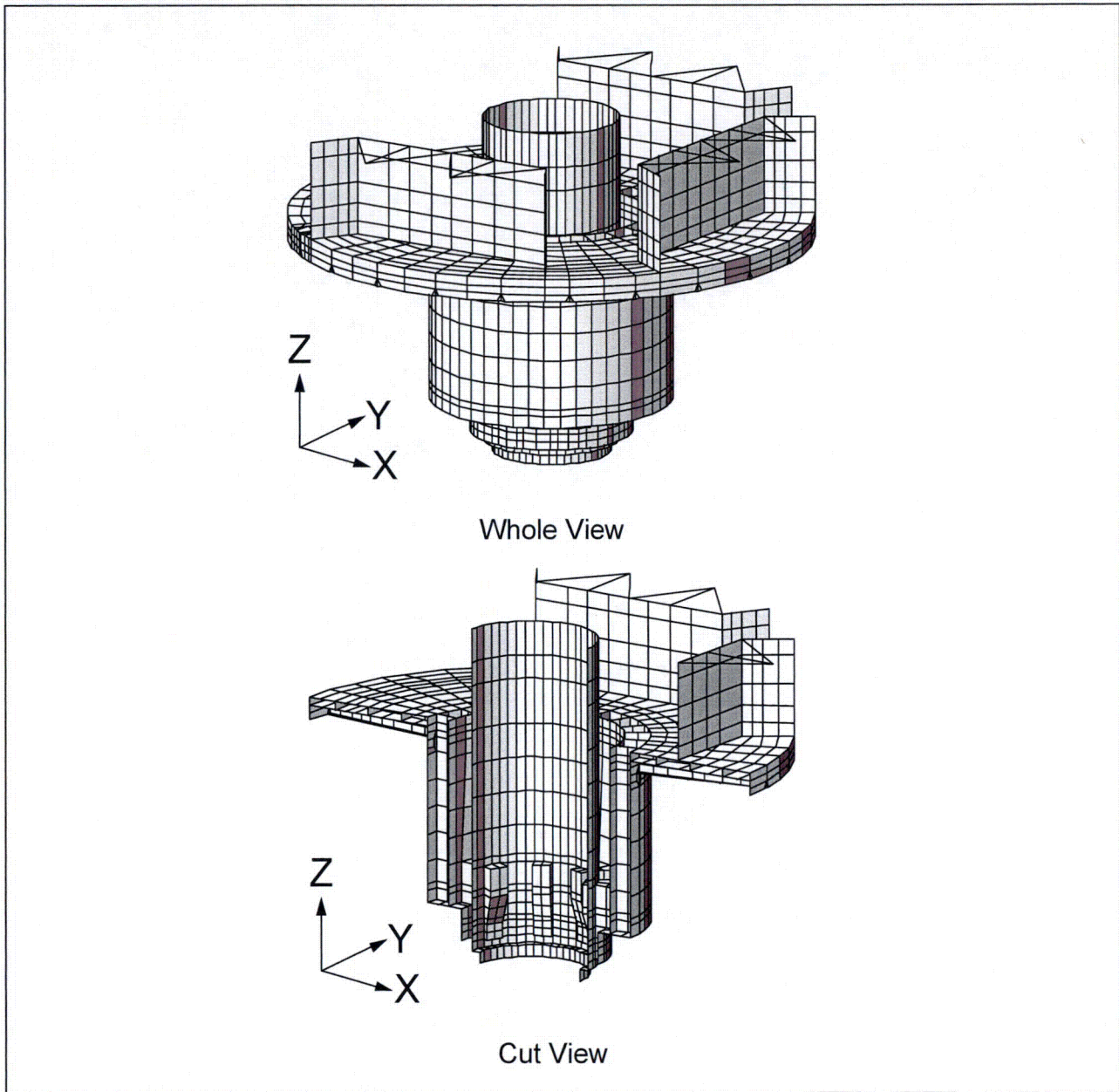


Figure 6.2.2-4 FE Model of RCCV Internal Structures

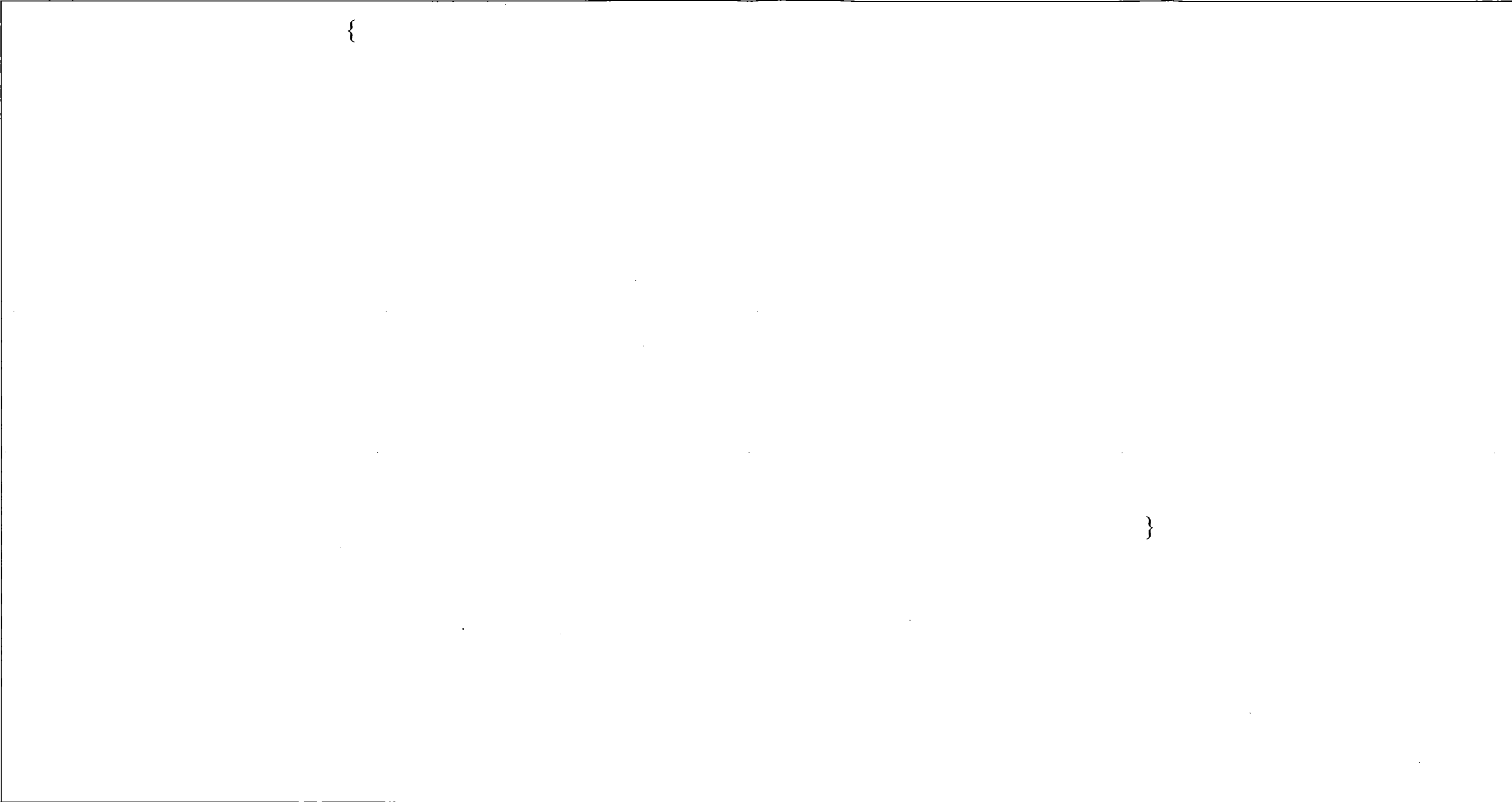


Figure 6.2.2-5 FE Model of the Basemat

{{{Contains Security-Related Information – Withheld Under 10 CFR 2.390.}}}

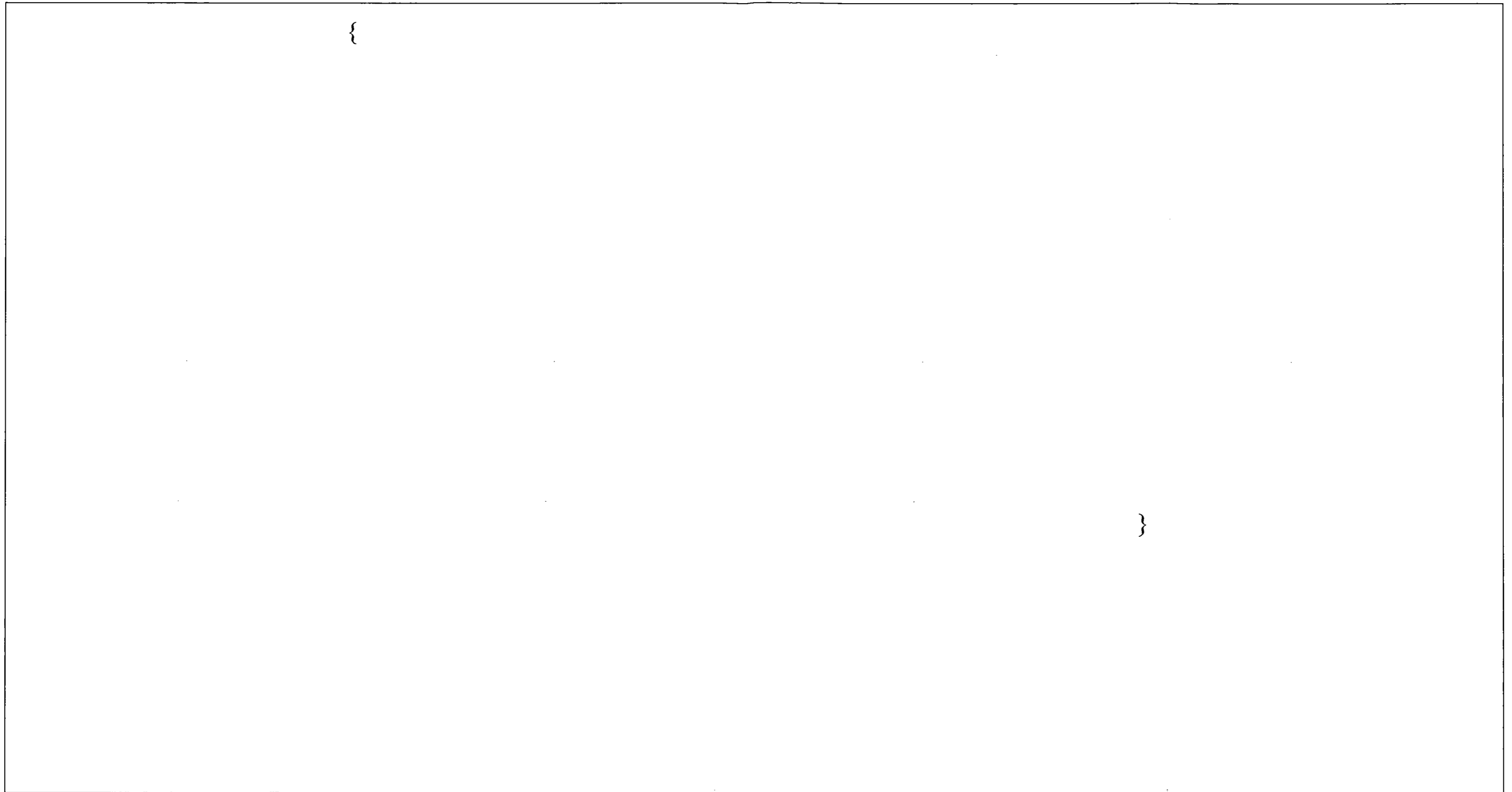


Figure 6.2.2-6 FE Model of the Basemat inside the Containment

{{{Contains Security-Related Information – Withheld Under 10 CFR 2.390.}}}

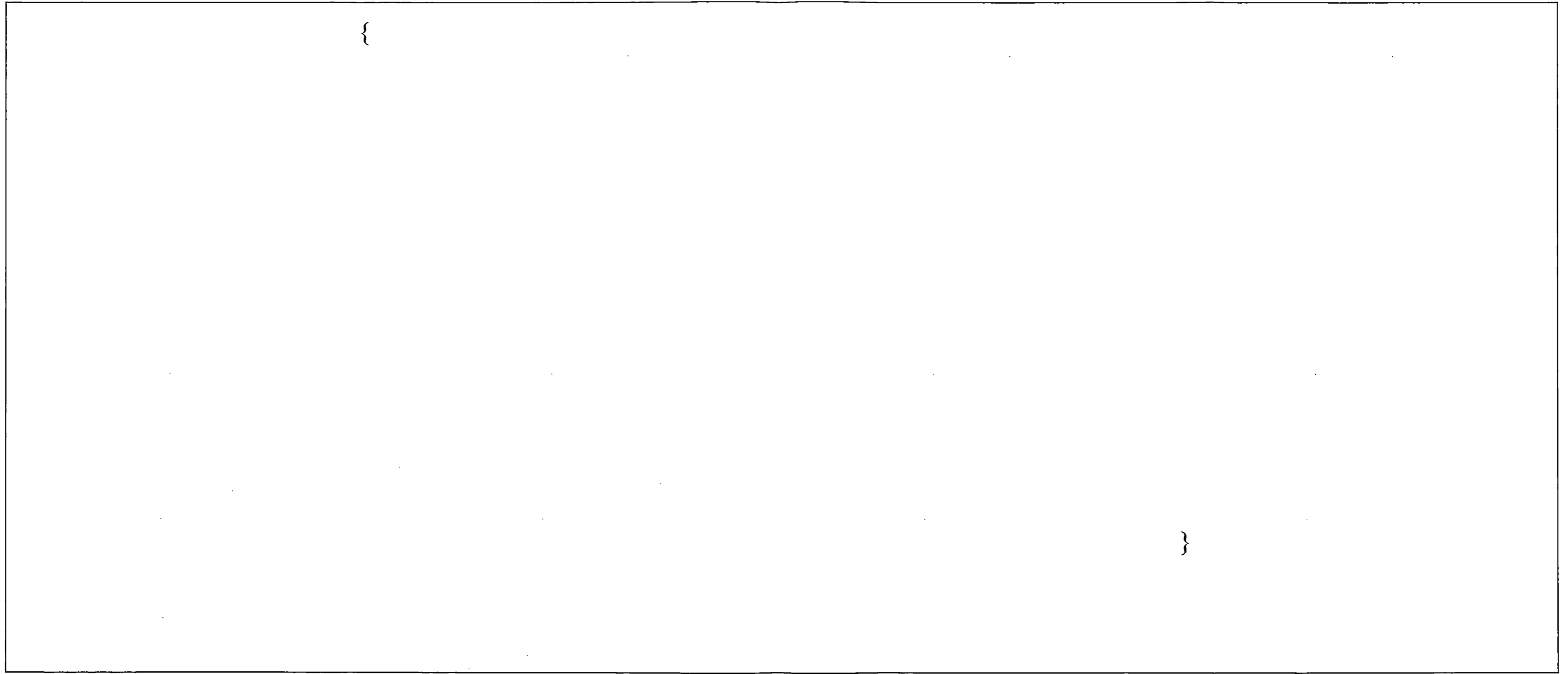


Figure 6.2.2-7 FE Model of the RCCV Cylinder Wall and the Wall below RCCV

{{{Contains Security-Related Information – Withheld Under 10 CFR 2.390.}}}

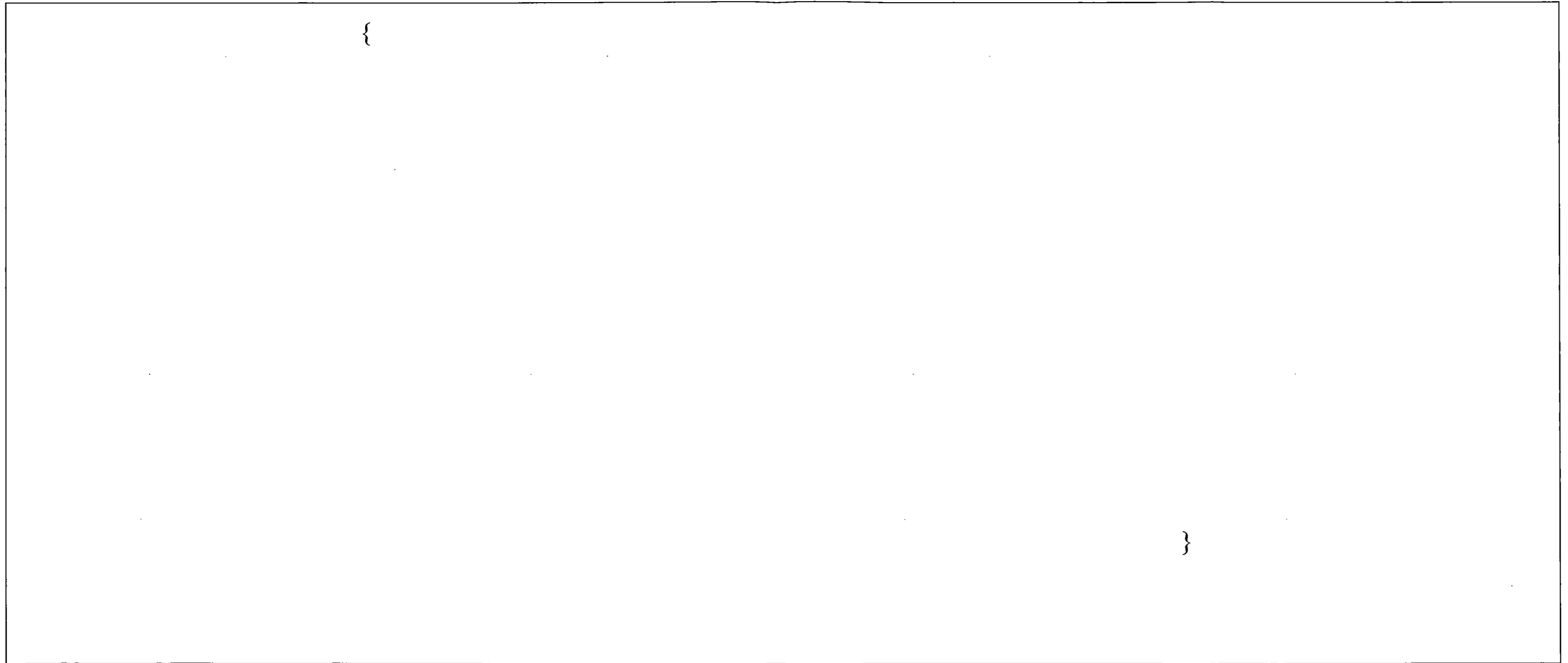


Figure 6.2.2-8 FE Model of the RPV Pedestal Wall

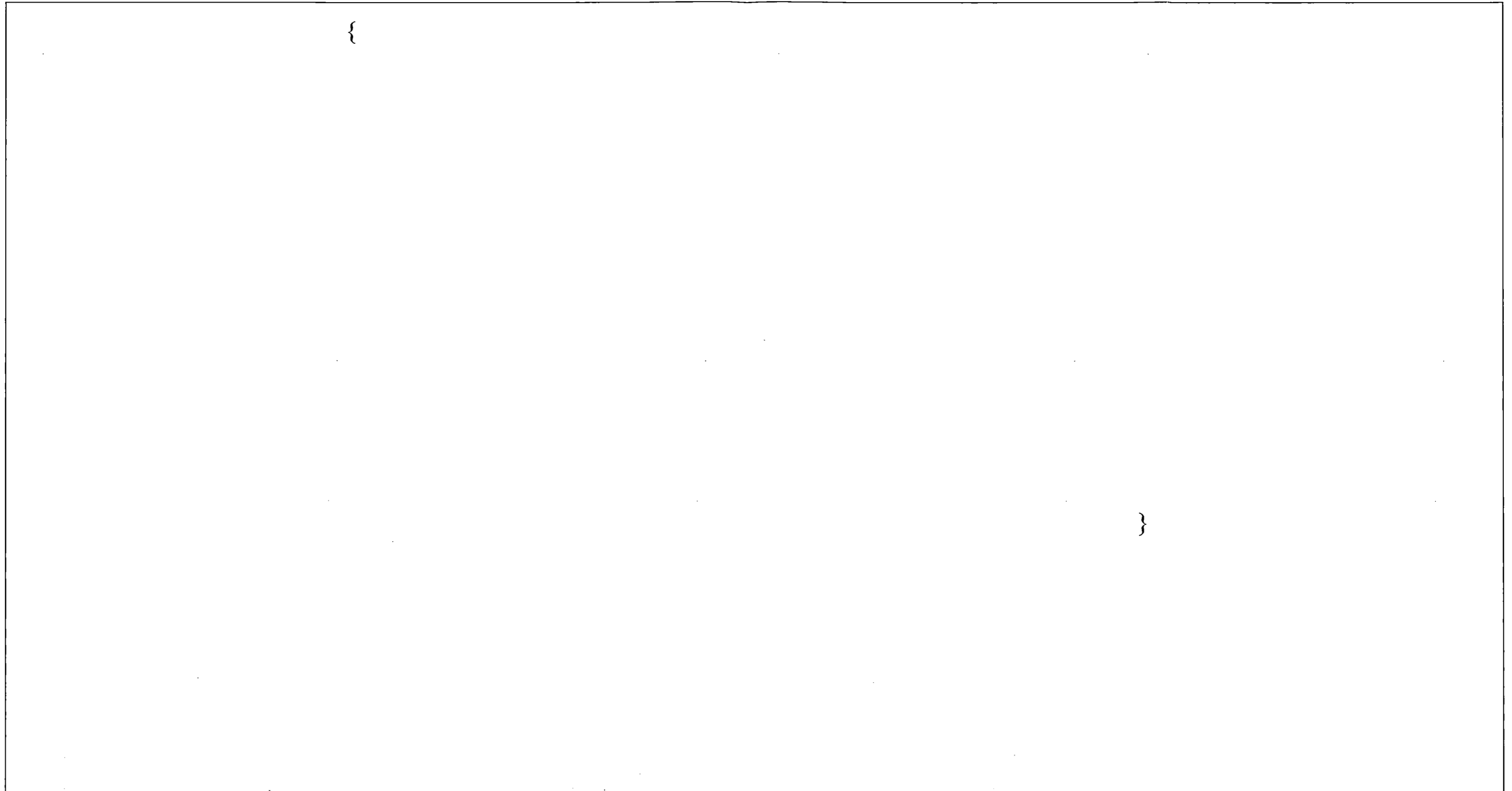


Figure 6.2.2-9 FE Model of the Top Slab

{{{Contains Security-Related Information – Withheld Under 10 CFR 2.390.}}}

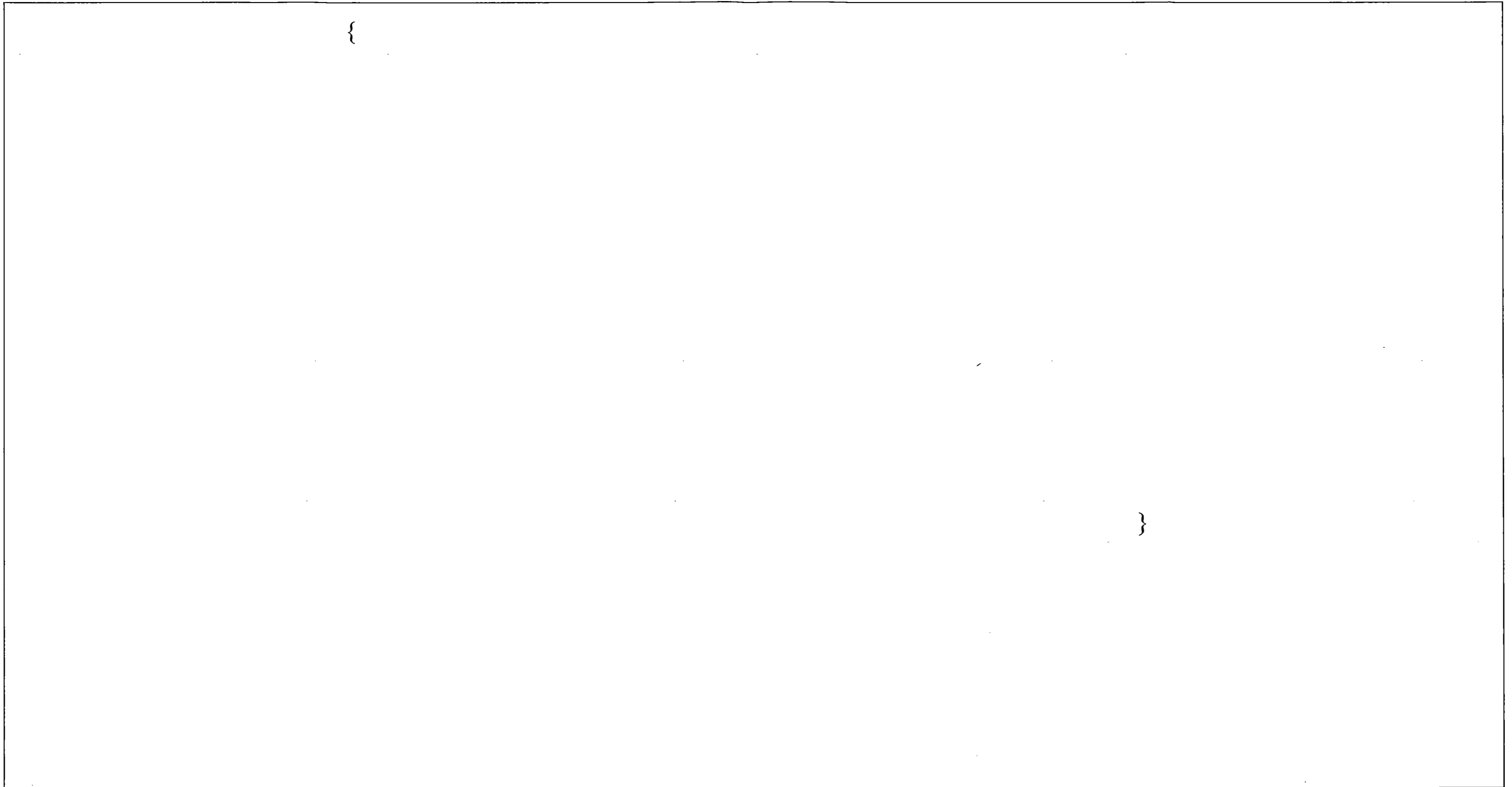


Figure 6.2.2-10 FE Model of the Suppression Pool Floor Slab

{{{Contains Security-Related Information – Withheld Under 10 CFR 2.390.}}}

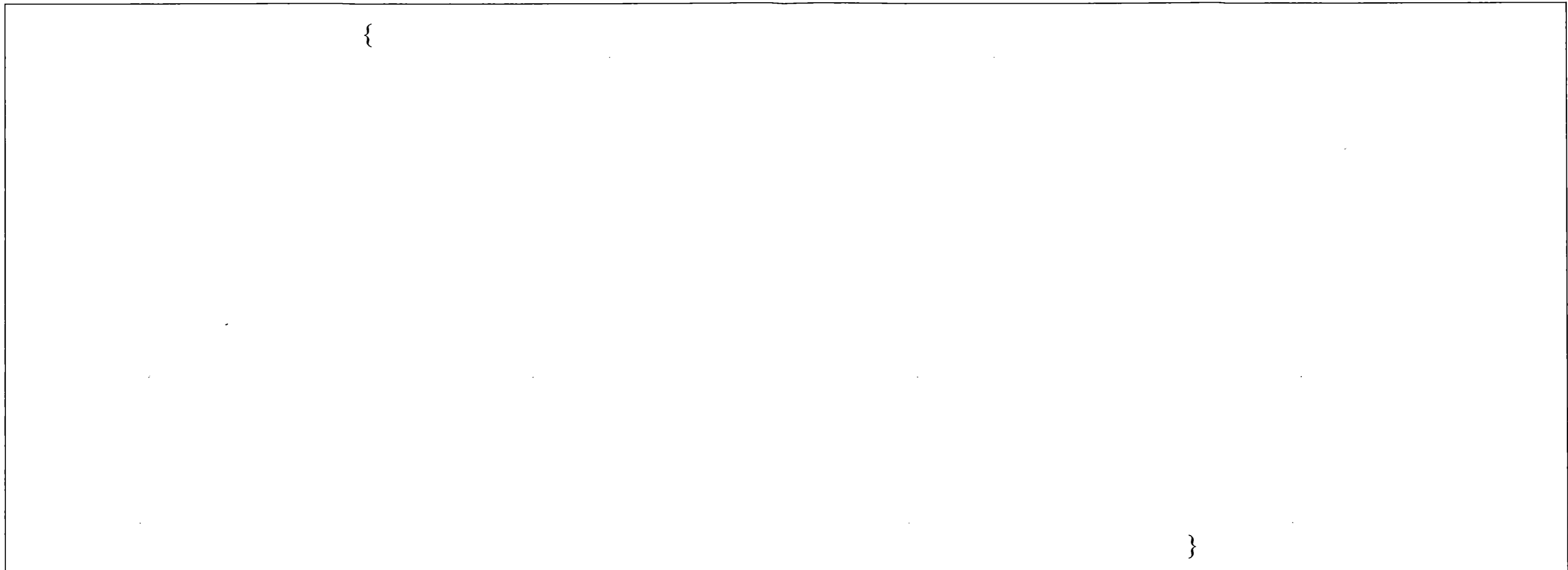


Figure 6.2.2-11 FE Model of the RCCV Cylinder Wall Liner

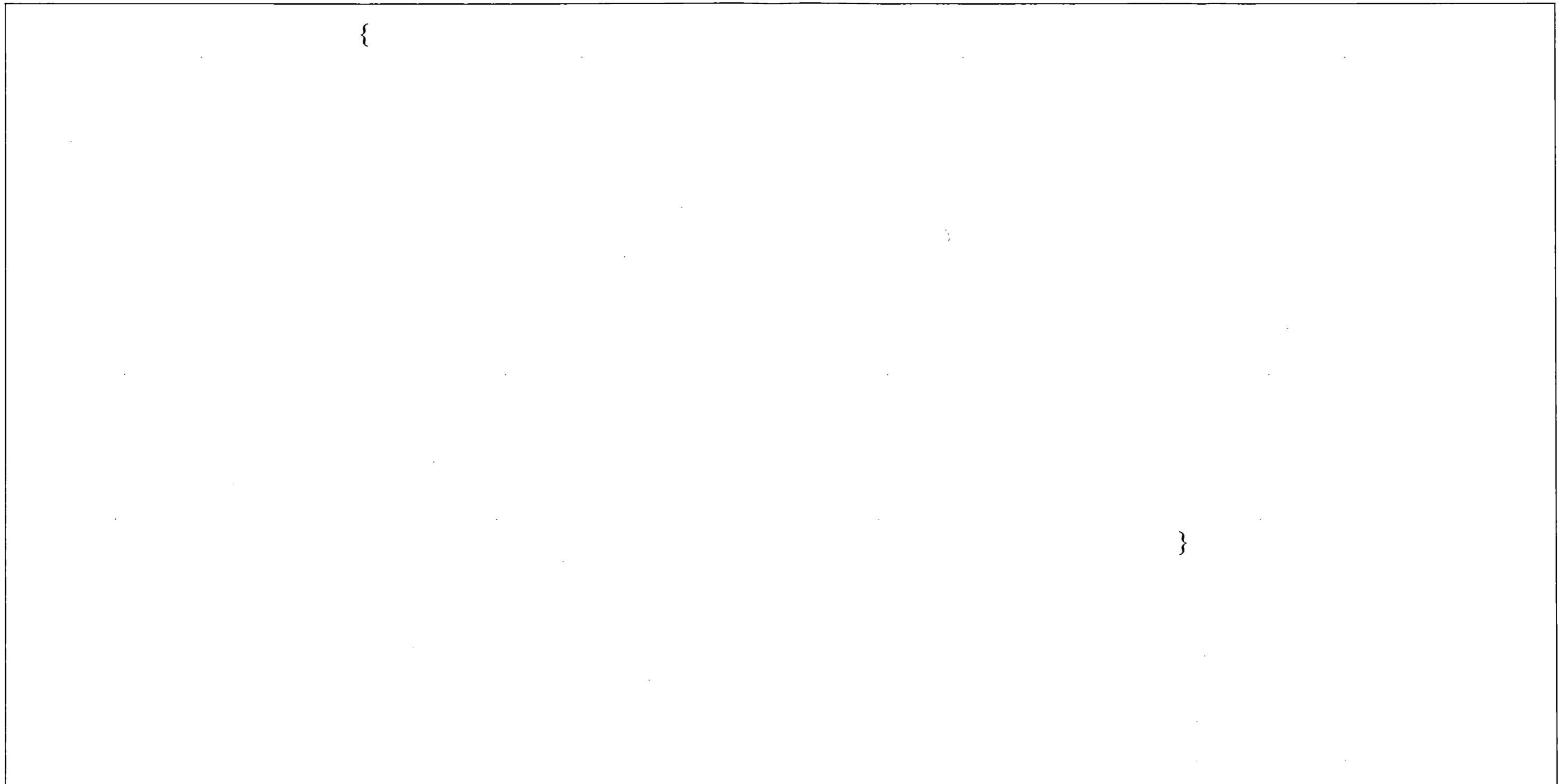


Figure 6.2.2-12 FE Model of the RPV Pedestal Wall Liner

{{{Contains Security-Related Information – Withheld Under 10 CFR 2.390.}}}

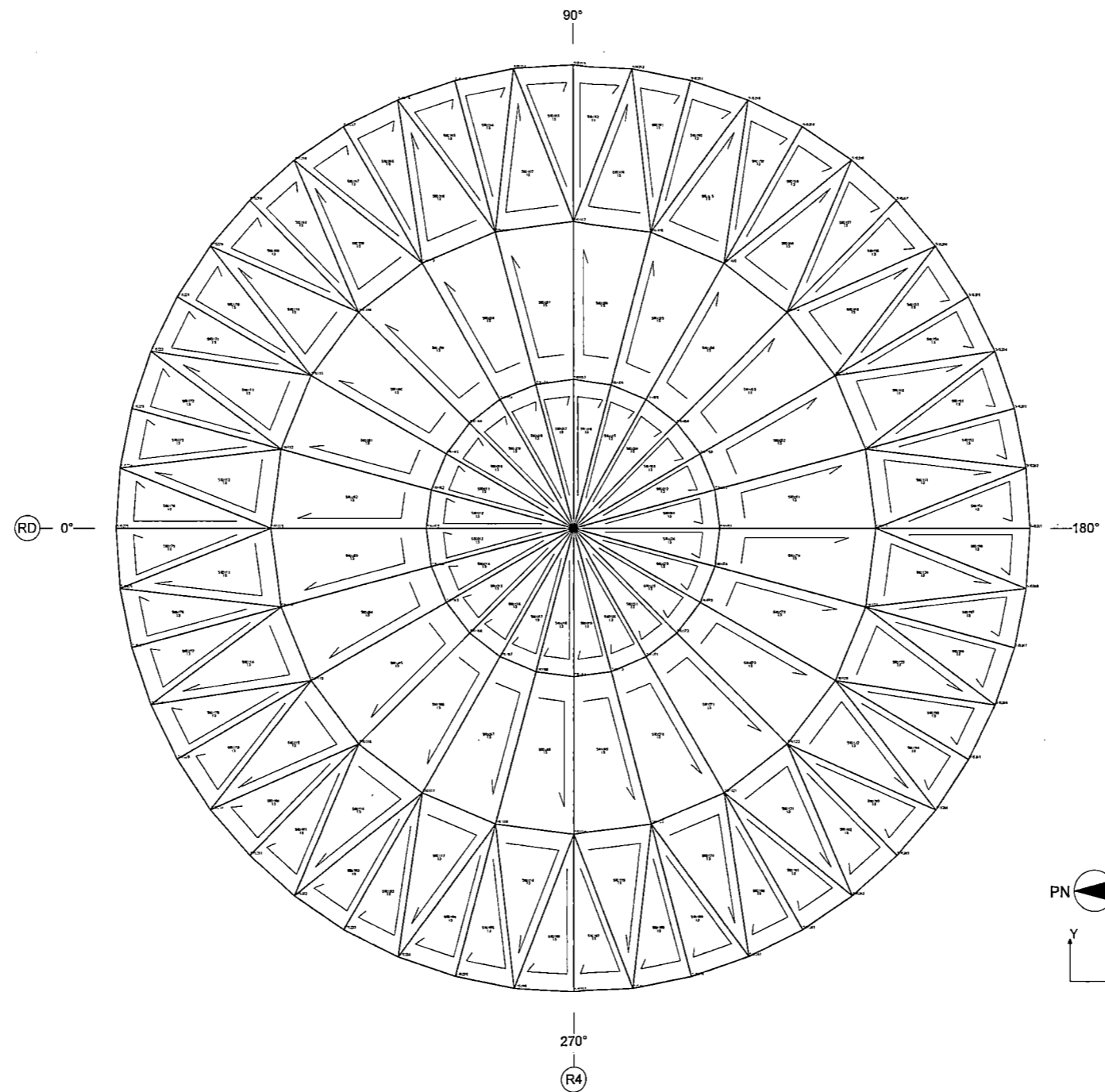


Figure 6.2.2-13 FE Model of the Basemat Liner (EL -10,400)

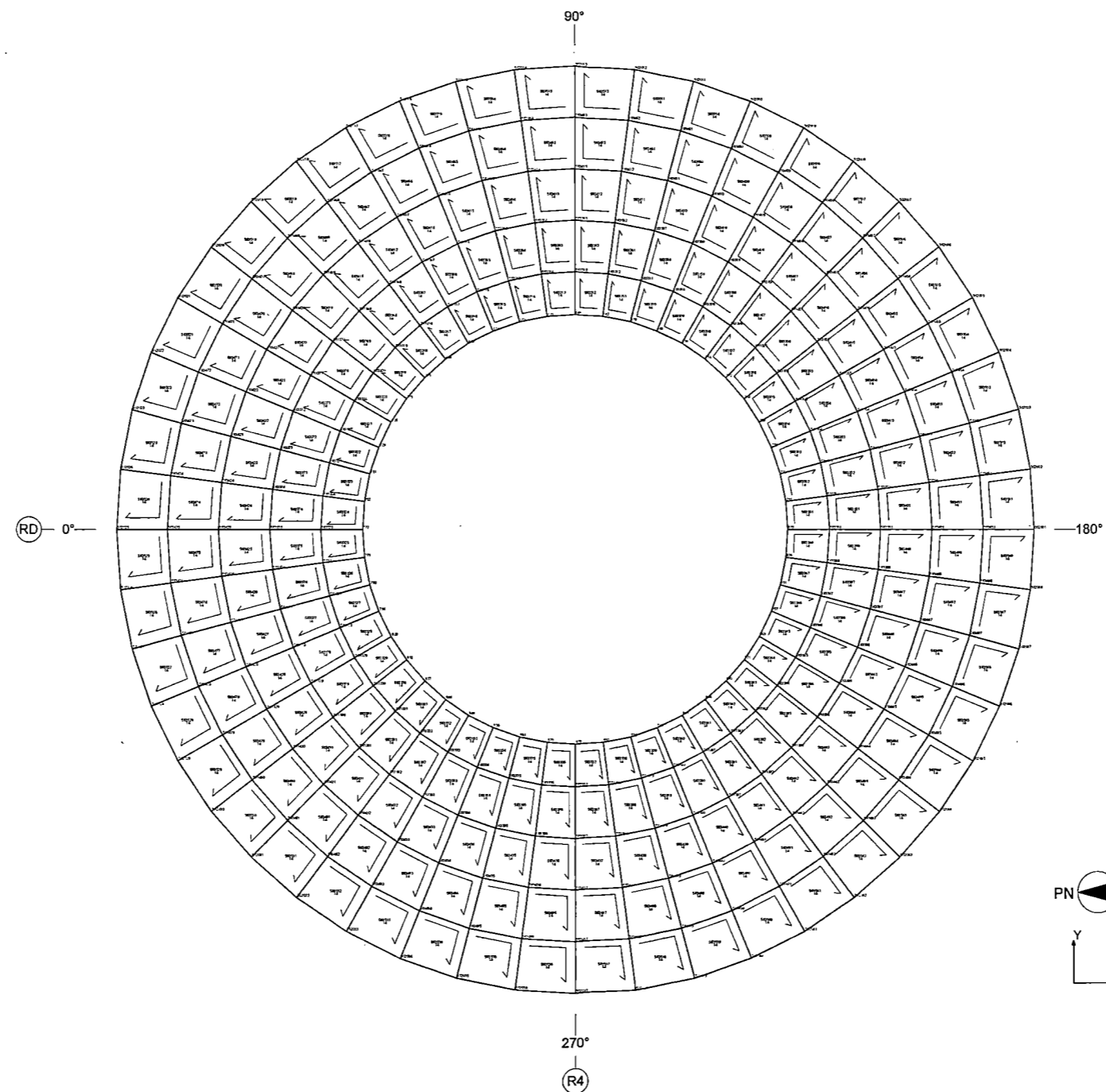


Figure 6.2.2-14 FE Model of the Suppression Pool Floor Slab Liner (EL 4,650)

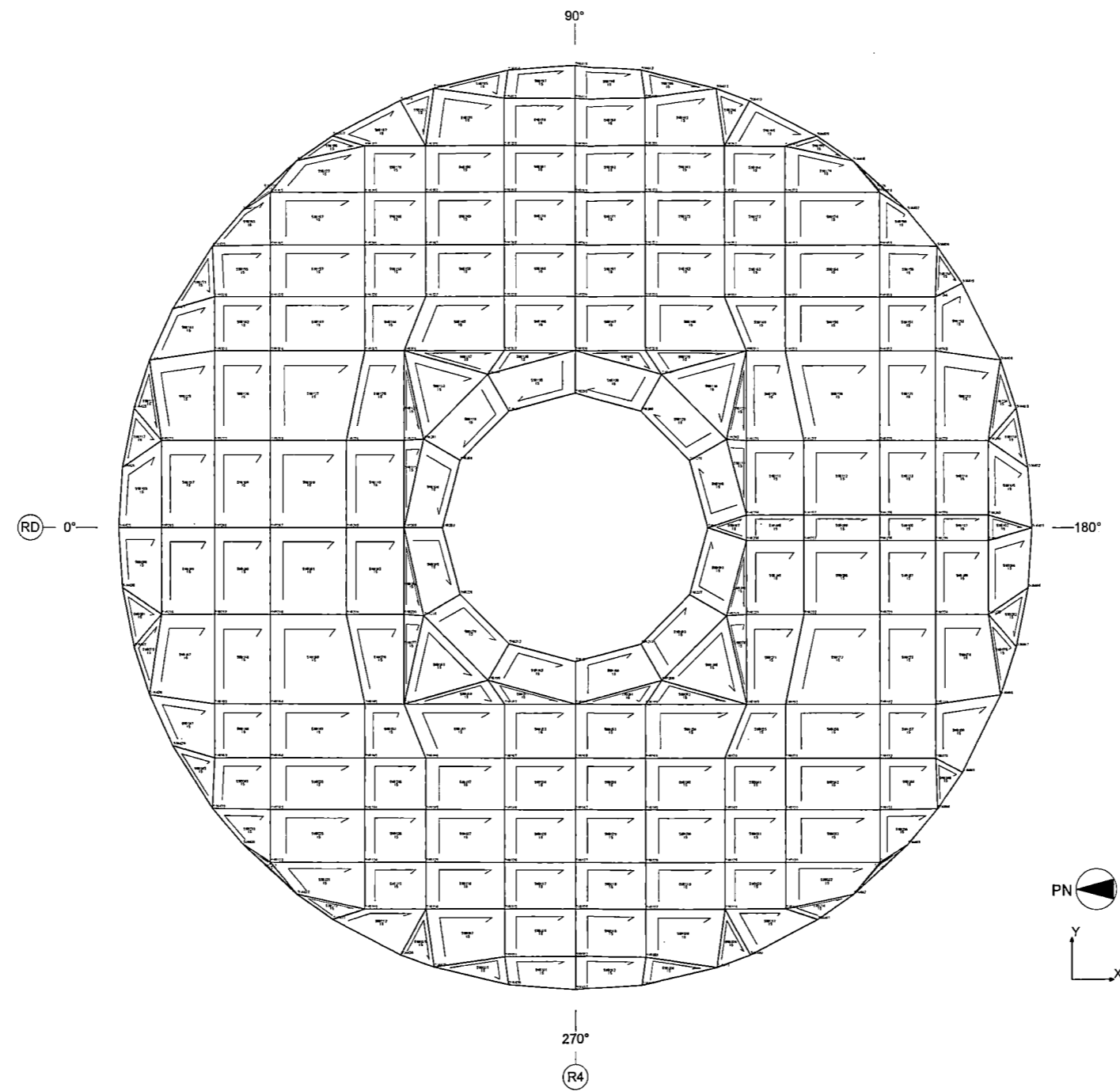


Figure 6.2.2-15 FE Model of the Top Slab Liner (EL 24,600)

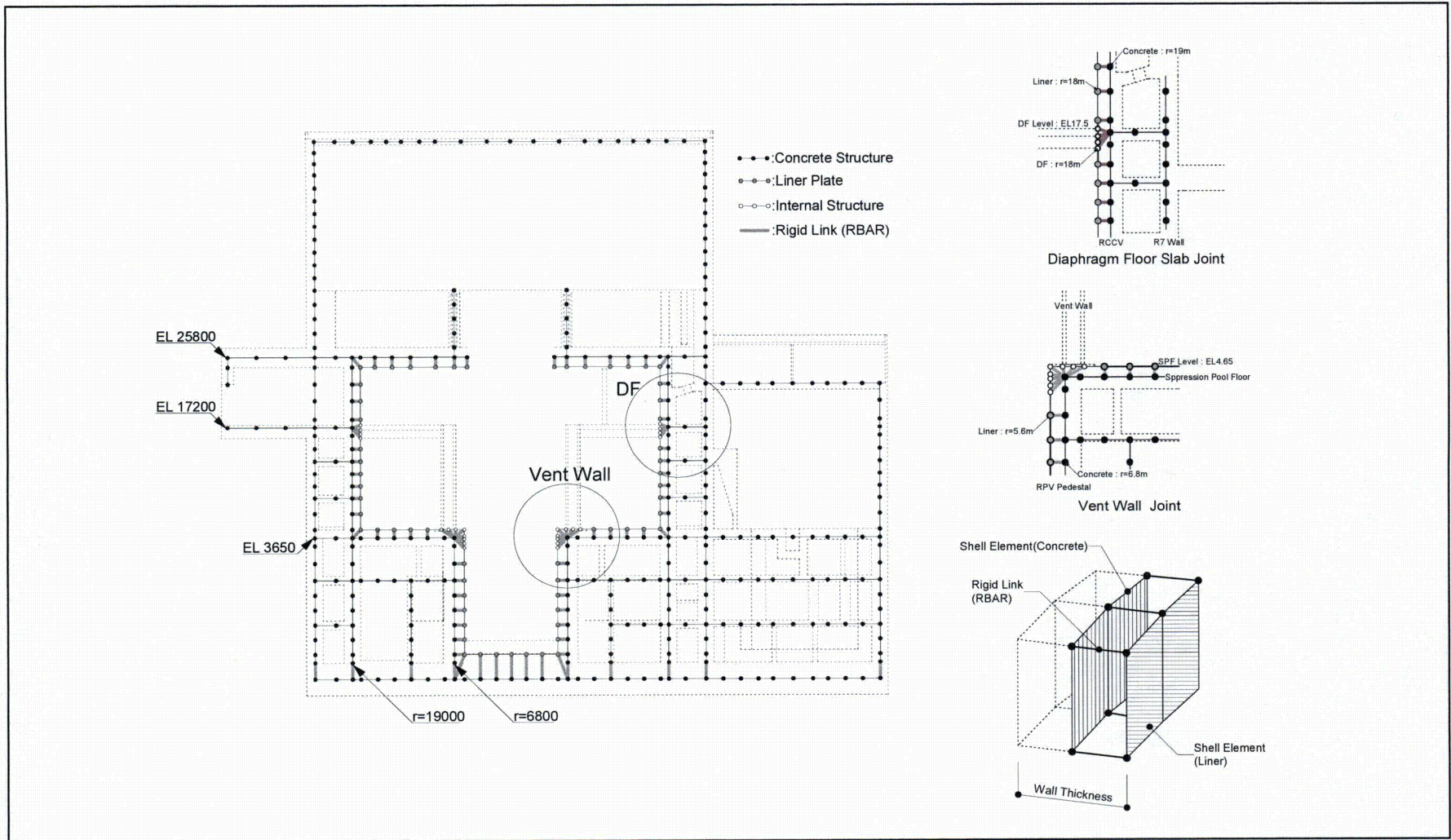


Figure 6.2.2-16 Rigid Bar Elements between Concrete and Liner

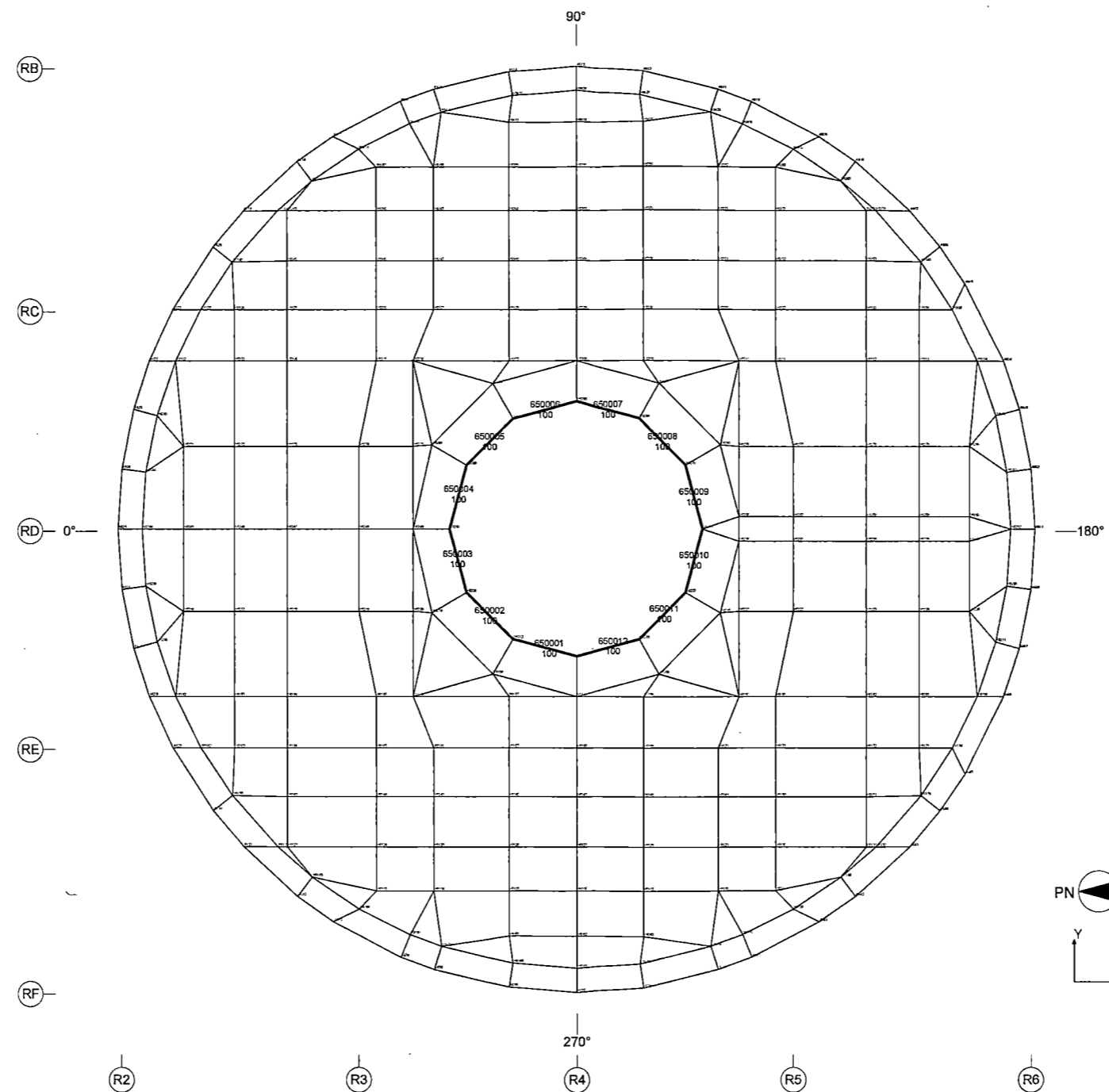


Figure 6.2.2-17 FE Model of Sleeve at the RCCV Top Head Opening

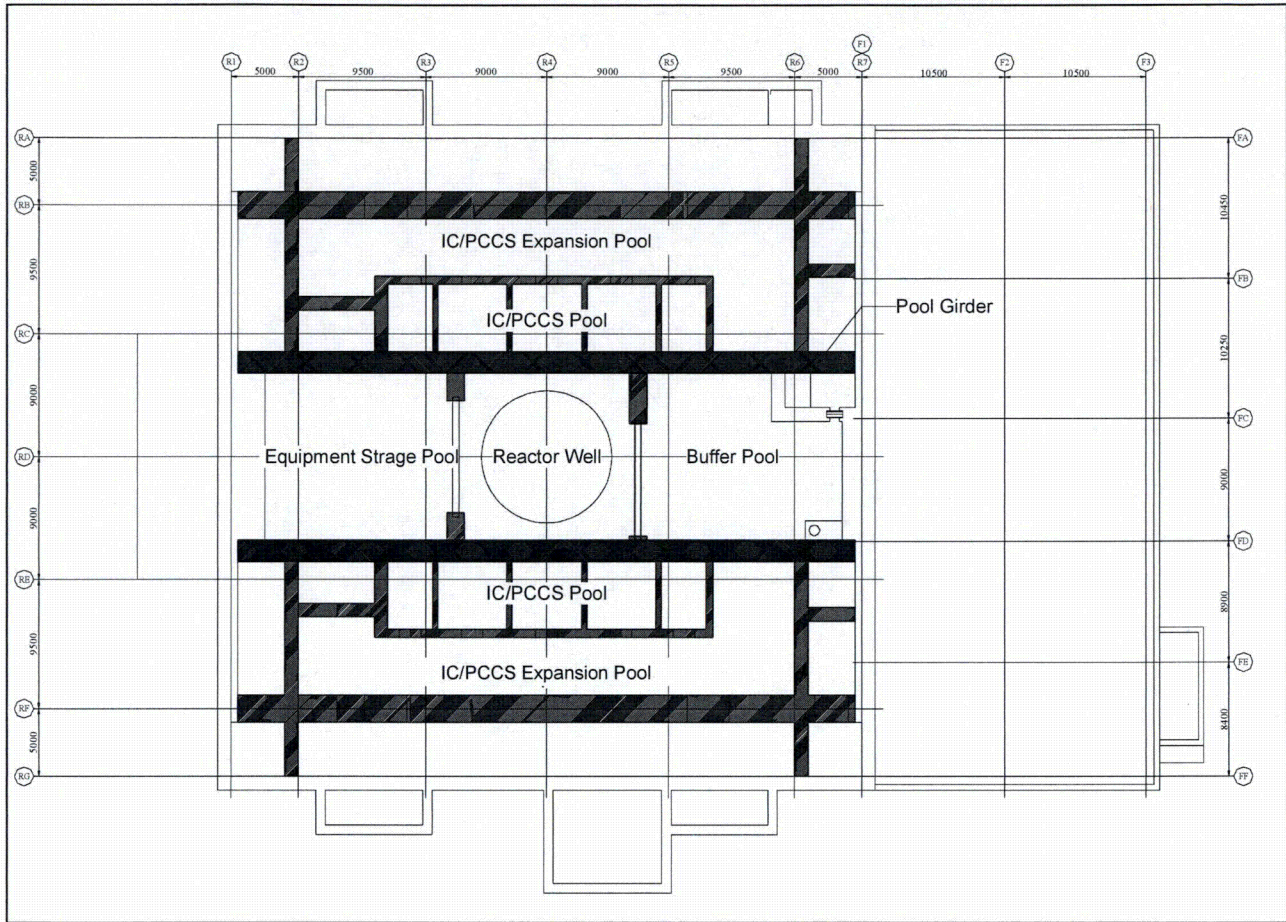
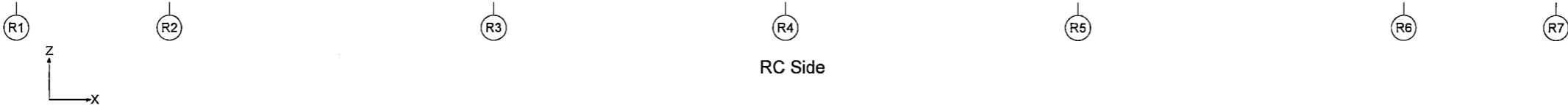


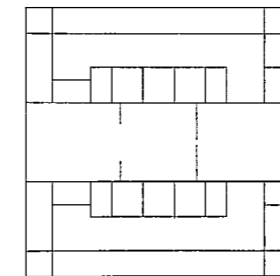
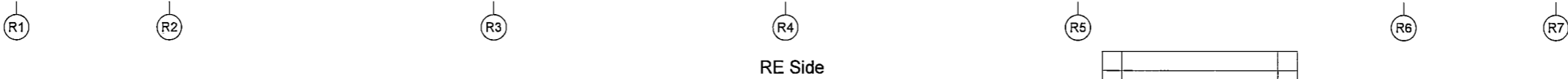
Figure 6.2.2-18 Modeled RB Pool Walls Except External Walls at EL 27,000



15472	99298	99300	99301	99302	99303	99304	99305	99306	99307	99308	99309	99310	99311	99312	99313	99314	99315	99316	99317	15436	EL 34.0
122001	122002	122003	122004	122005	122006	122007	122008	122009	122010	122011	122012	122013	122014	122015	122016	122017	122018	122019	122020		
15472	498199	498200	498201	498202	498203	498204	498205	498206	498207	498208	498209	498210	498211	498212	498213	498214	498215	498216	498217	15436	
122151	122152	122153	122154	122155	122156	122157	122158	122159	122160	122161	122162	122163	122164	122165	122166	122167	122168	122169	122170		
15272	398199	398200	398201	398202	398203	398204	398205	398206	398207	398208	398209	398210	398211	398212	398213	398214	398215	398216	398217	15236	
122101	122102	122103	122104	122105	122106	122107	122108	122109	122110	122111	122112	122113	122114	122115	122116	122117	122118	122119	122120		
15072	298199	298200	298201	298202	298203	298204	298205	298206	298207	298208	298209	298210	298211	298212	298213	298214	298215	298216	298217	15036	
122051	122052	122053	122054	122055	122056	122057	122058	122059	122060	122061	122062	122063	122064	122065	122066	122067	122068	122069	122070		
14872	198199	198200	198201	198202	198203	198204	198205	198206	198207	198208	198209	198210	198211	198212	198213	198214	198215	198216	198217	14836	
122001	122002	122003	122004	122005	122006	122007	122008	122009	122010	122011	122012	122013	122014	122015	122016	122017	122018	122019	122020		
14672	98199	98200	98201	98202	98203	98204	98205	98206	98207	98208	98209	98210	98211	98212	98213	98214	98215	98216	98217	14636	EL 25.8



15478	99179	99180	99181	99182	99183	99184	99185	99186	99187	99188	99189	99190	99191	99192	99193	99194	99195	99196	99197	15439	EL 34.0
122001	122002	122003	122004	122005	122006	122007	122008	122009	122010	122011	122012	122013	122014	122015	122016	122017	122018	122019	122020		
15478	498179	498180	498181	498182	498183	498184	498185	498186	498187	498188	498189	498190	498191	498192	498193	498194	498195	498196	498197	15439	
122151	122152	122153	122154	122155	122156	122157	122158	122159	122160	122161	122162	122163	122164	122165	122166	122167	122168	122169	122170		
15278	398179	398180	398181	398182	398183	398184	398185	398186	398187	398188	398189	398190	398191	398192	398193	398194	398195	398196	398197	15239	
122101	122102	122103	122104	122105	122106	122107	122108	122109	122110	122111	122112	122113	122114	122115	122116	122117	122118	122119	122120		
15078	298179	298180	298181	298182	298183	298184	298185	298186	298187	298188	298189	298190	298191	298192	298193	298194	298195	298196	298197	15039	
122051	122052	122053	122054	122055	122056	122057	122058	122059	122060	122061	122062	122063	122064	122065	122066	122067	122068	122069	122070		
14878	198179	198180	198181	198182	198183	198184	198185	198186	198187	198188	198189	198190	198191	198192	198193	198194	198195	198196	198197	14839	
122001	122002	122003	122004	122005	122006	122007	122008	122009	122010	122011	122012	122013	122014	122015	122016	122017	122018	122019	122020		
14678	98179	98180	98181	98182	98183	98184	98185	98186	98187	98188	98189	98190	98191	98192	98193	98194	98195	98196	98197	14639	EL 25.8



GRID-ID
ELEM-ID
PID

Figure 6.2.2-19 FE Model of the Pool Girders



HITACHI

WG3-U71-ERD-S-0004 SH NO. 275

REV. 0

of 538

{

}

Figure 6.2.2-20 Layout of Inner Walls Included in the Analysis Model at EL -11,500

{{{Contains Security-Related Information – Withheld Under 10 CFR 2.390.}}}



HITACHI

WG3-U71-ERD-S-0004 SH NO. 276

REV. 0

of 538

{

}

Figure 6.2.2-21 Layout of Inner Walls Included in the Analysis Model at EL -6,400

{{{Contains Security-Related Information – Withheld Under 10 CFR 2.390.}}}



HITACHI

WG3-U71-ERD-S-0004 SH NO. 277

REV. 0

of 538

{

}

Figure 6.2.2-22 Layout of Inner Walls Included in the Analysis Model at EL -1,000

{{{Contains Security-Related Information – Withheld Under 10 CFR 2.390.}}}

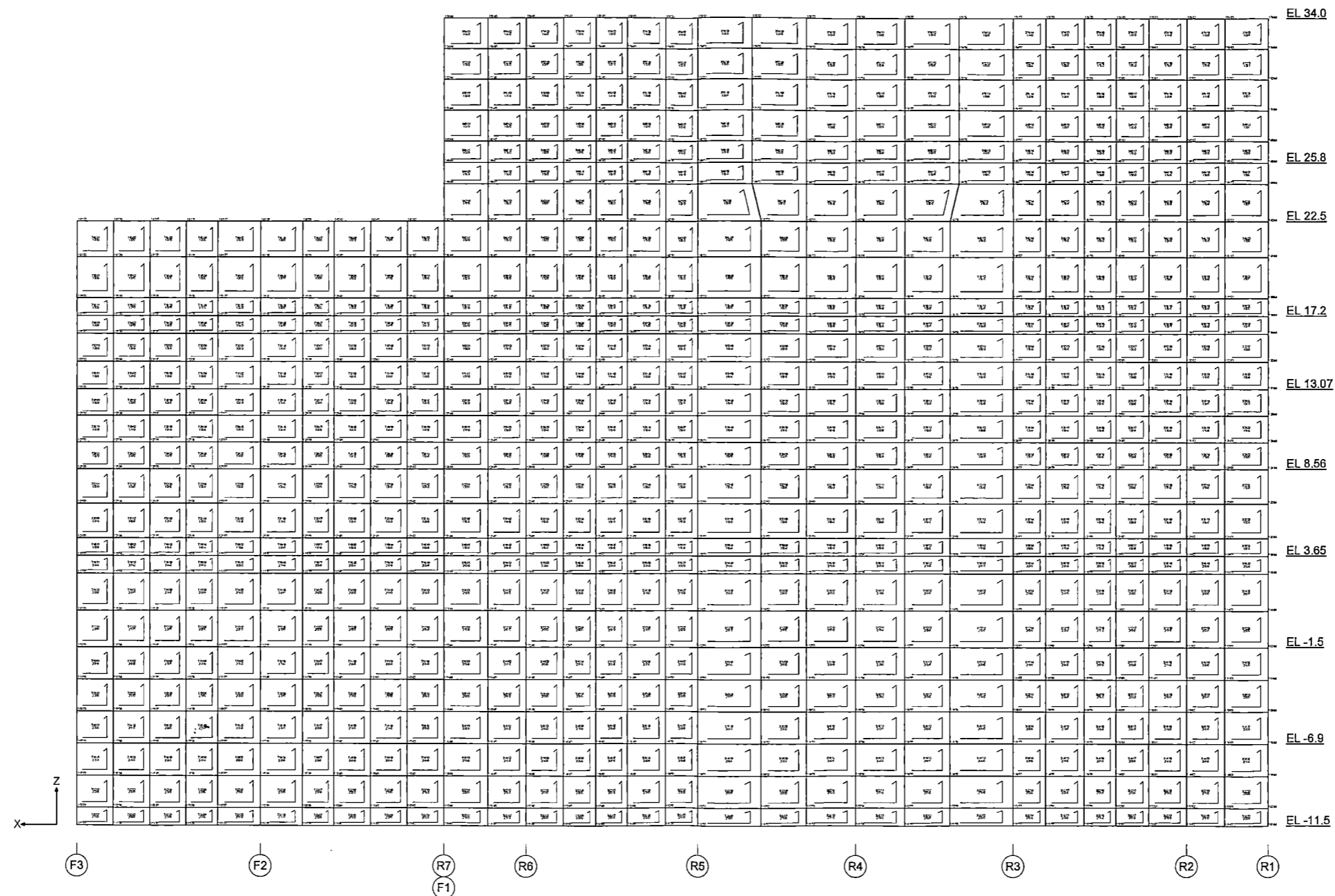


Figure 6.2.2-23 FE Model of the External Wall (RA/FA Column Line)

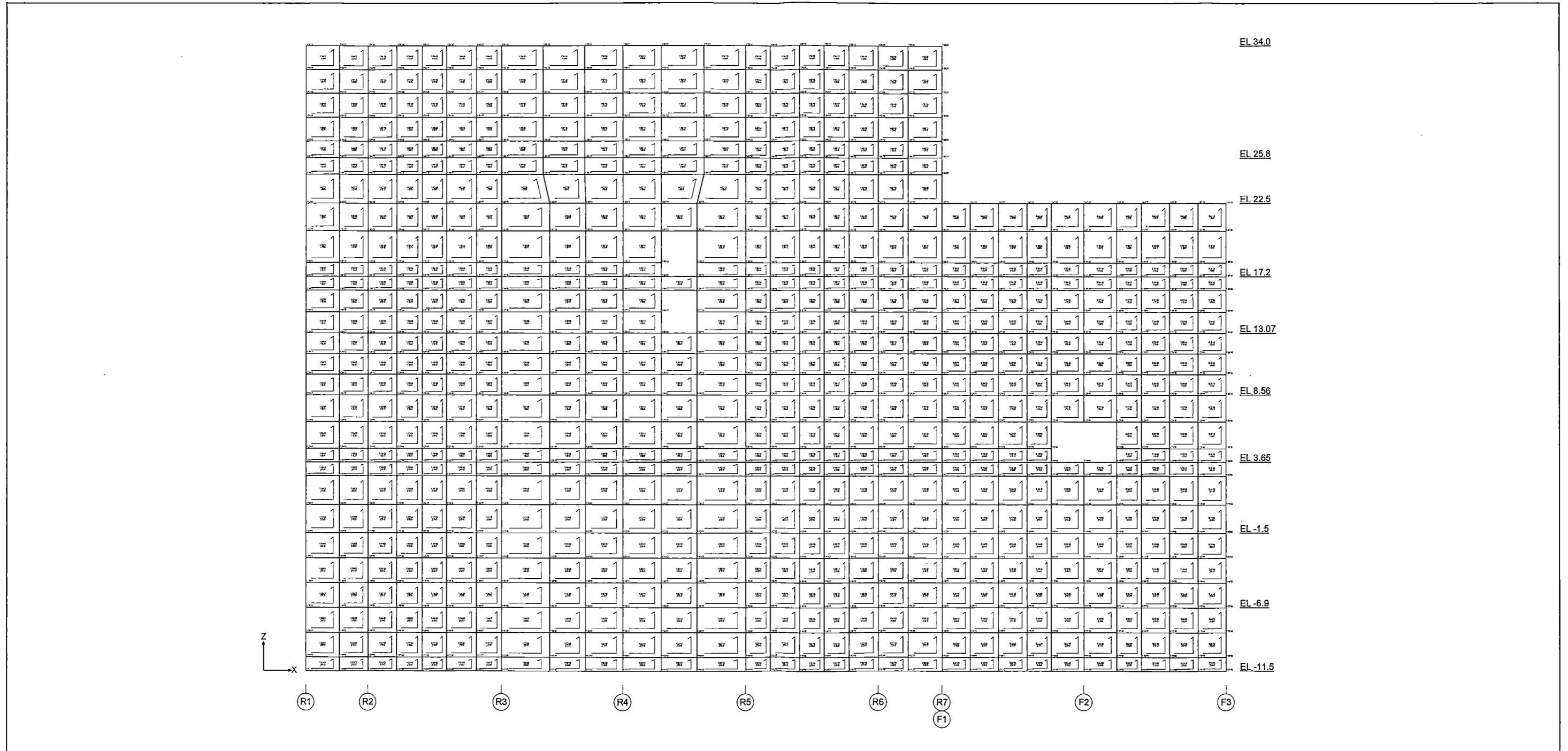


Figure 6.2.2-24 FE Model of the External Wall (RG/FF Column Line)

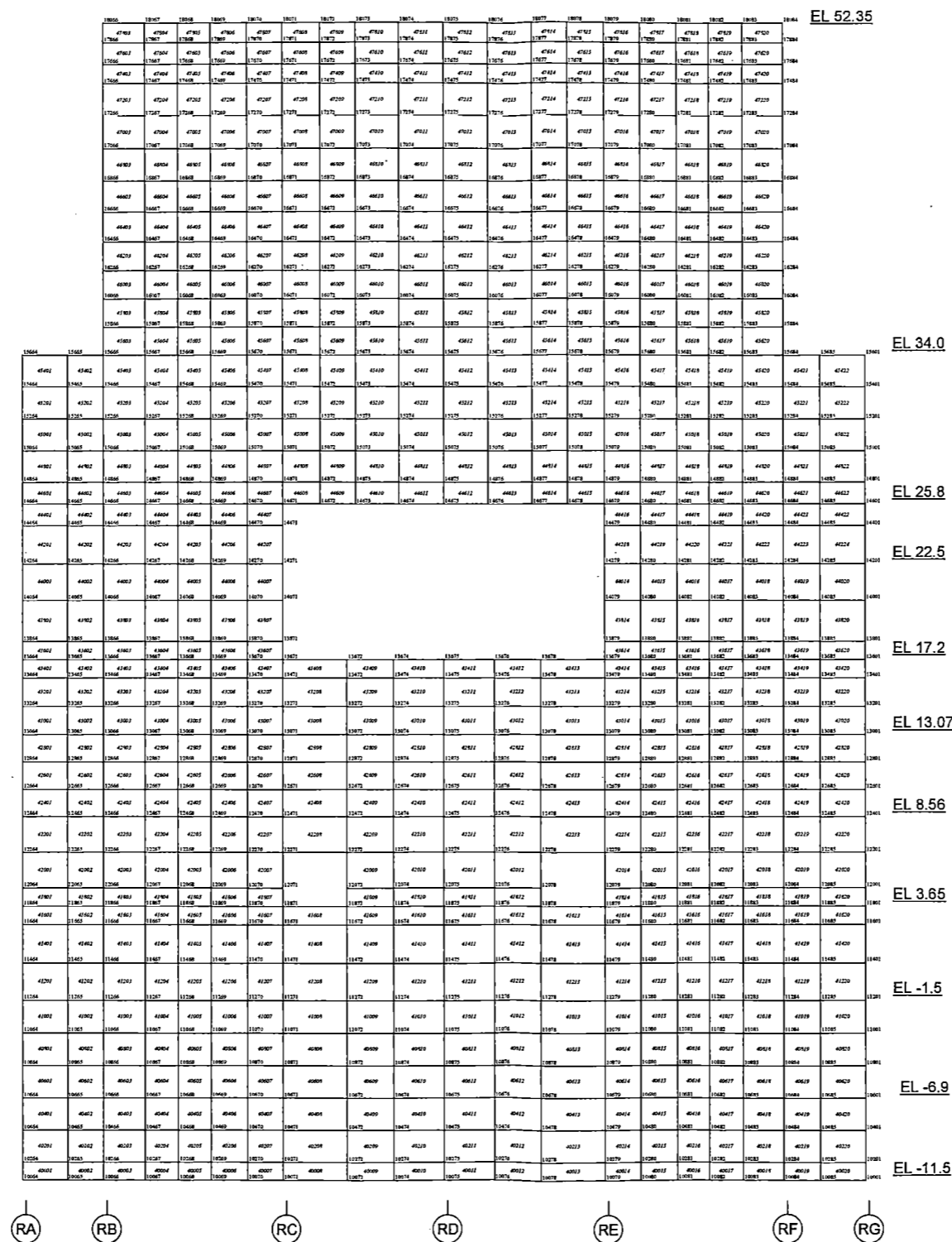


Figure 6.2-25 FE Model of the External Wall (R1 Column Line)

 GRID-ID
ELEM-ID

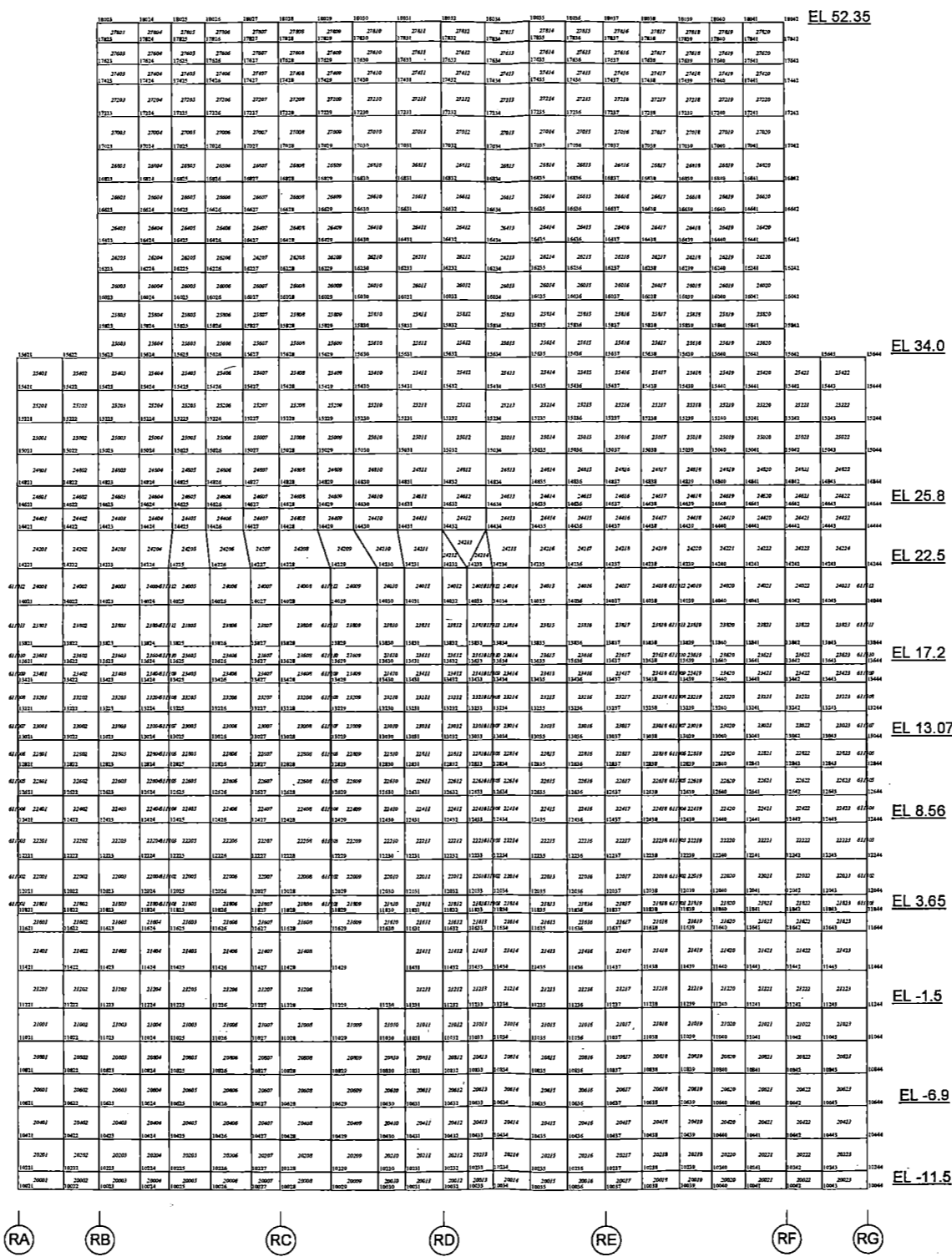


Figure 6.2-26 FE Model of the External Wall (R7/F1 Column Line)

GRID-ID
ELEM-ID

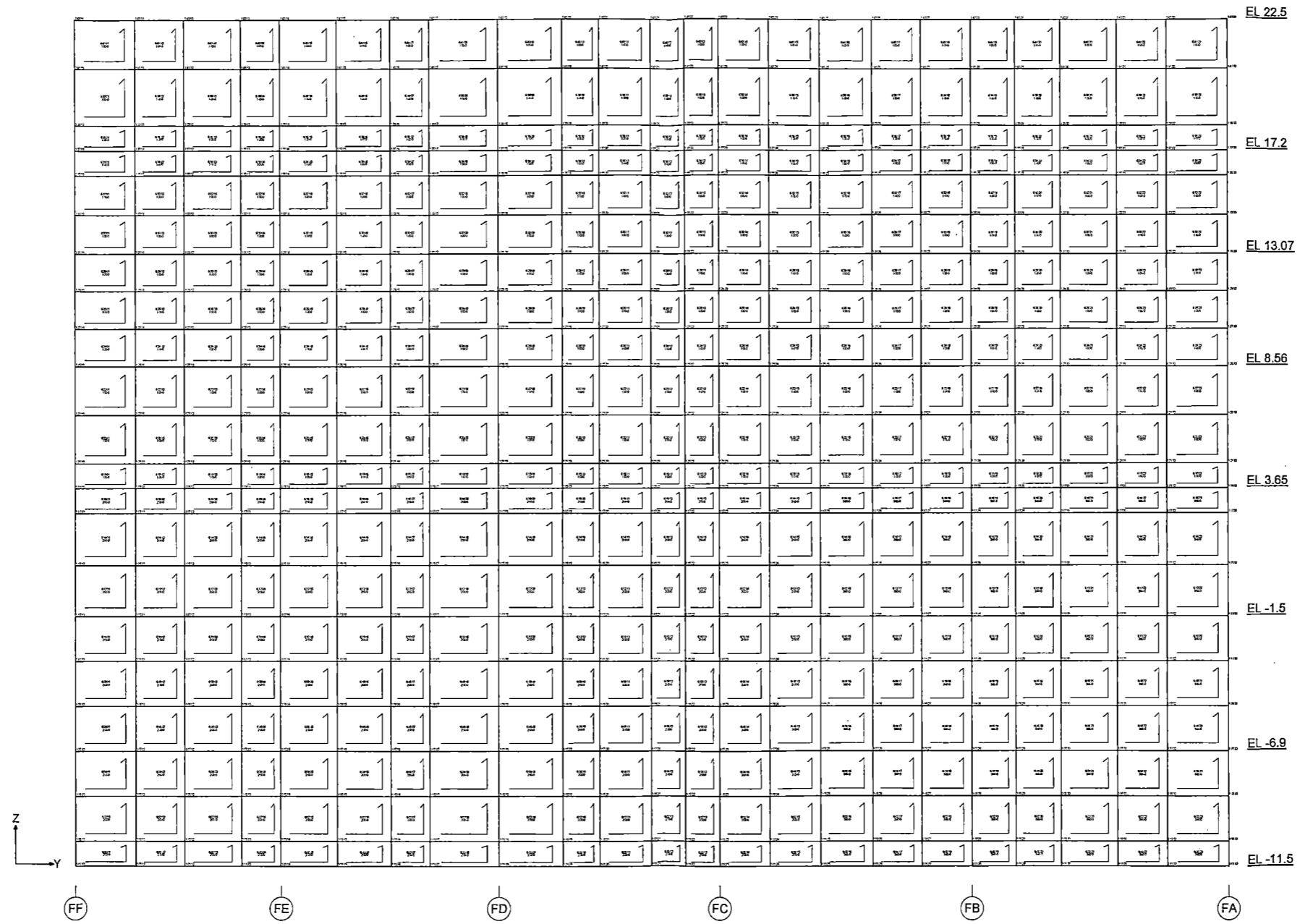


Figure 6.2.2-27 FE Model of the External Wall (F3 Column Line)

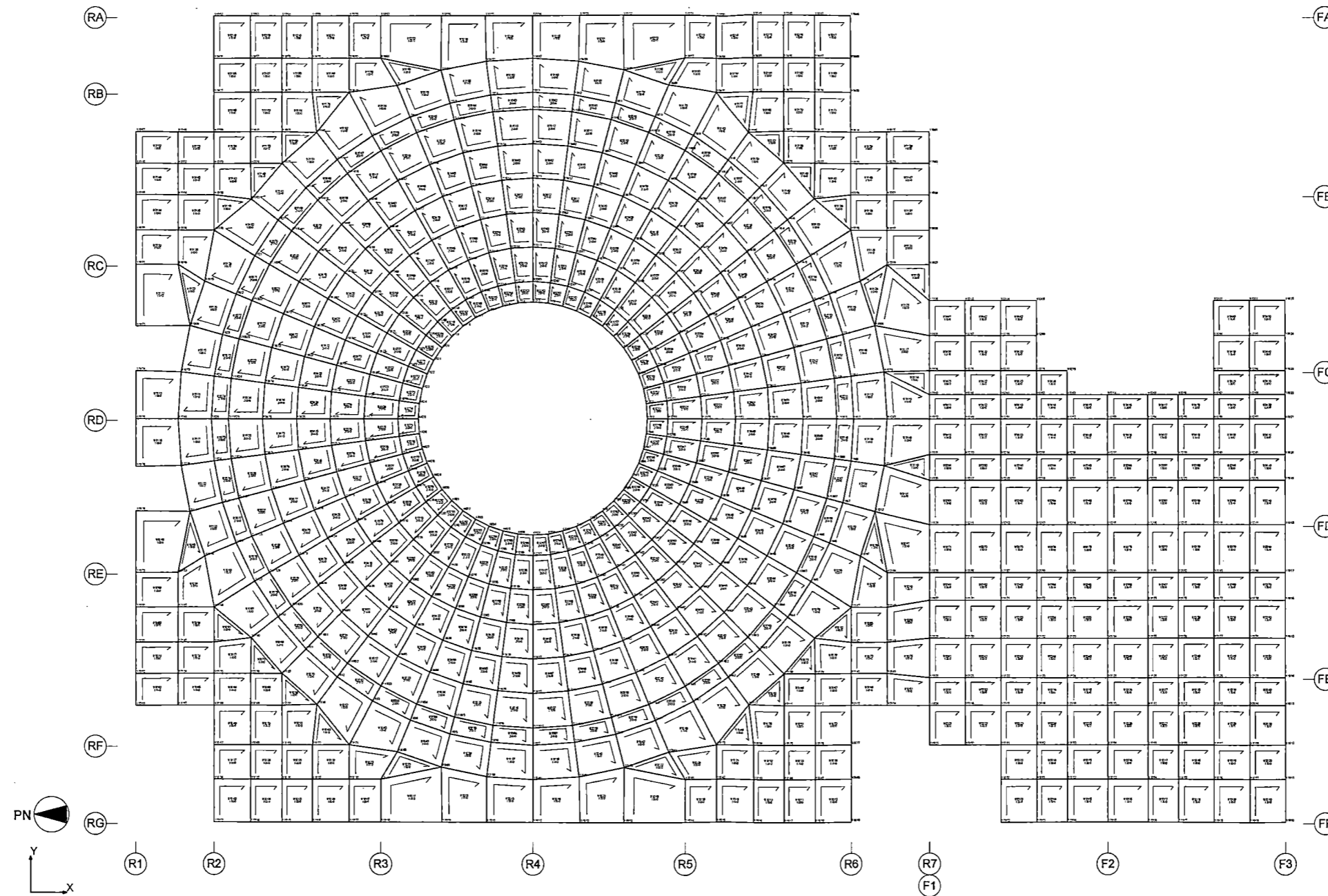


Figure 6.2.2-28 FE Model of the Slab at EL 4,650

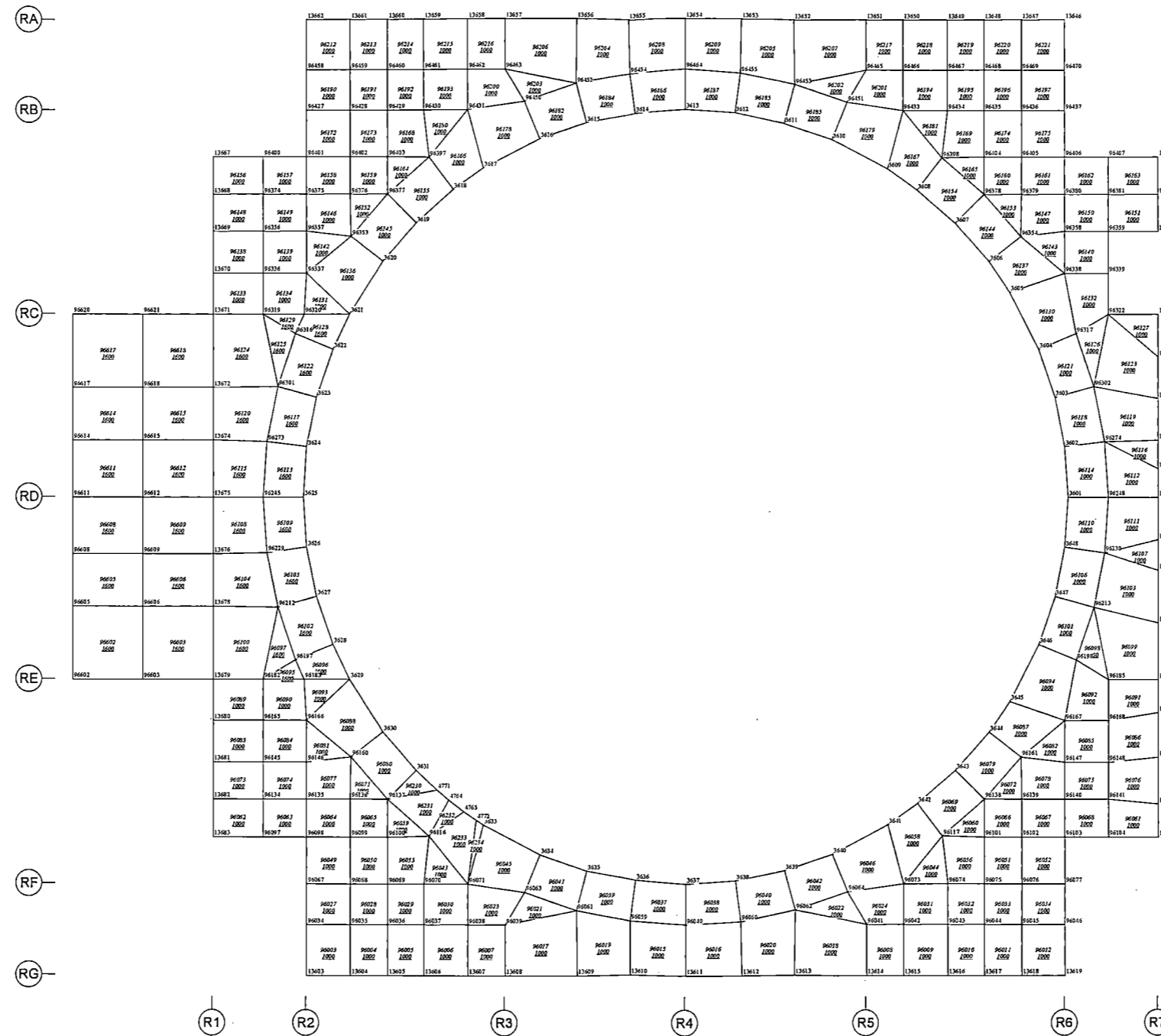
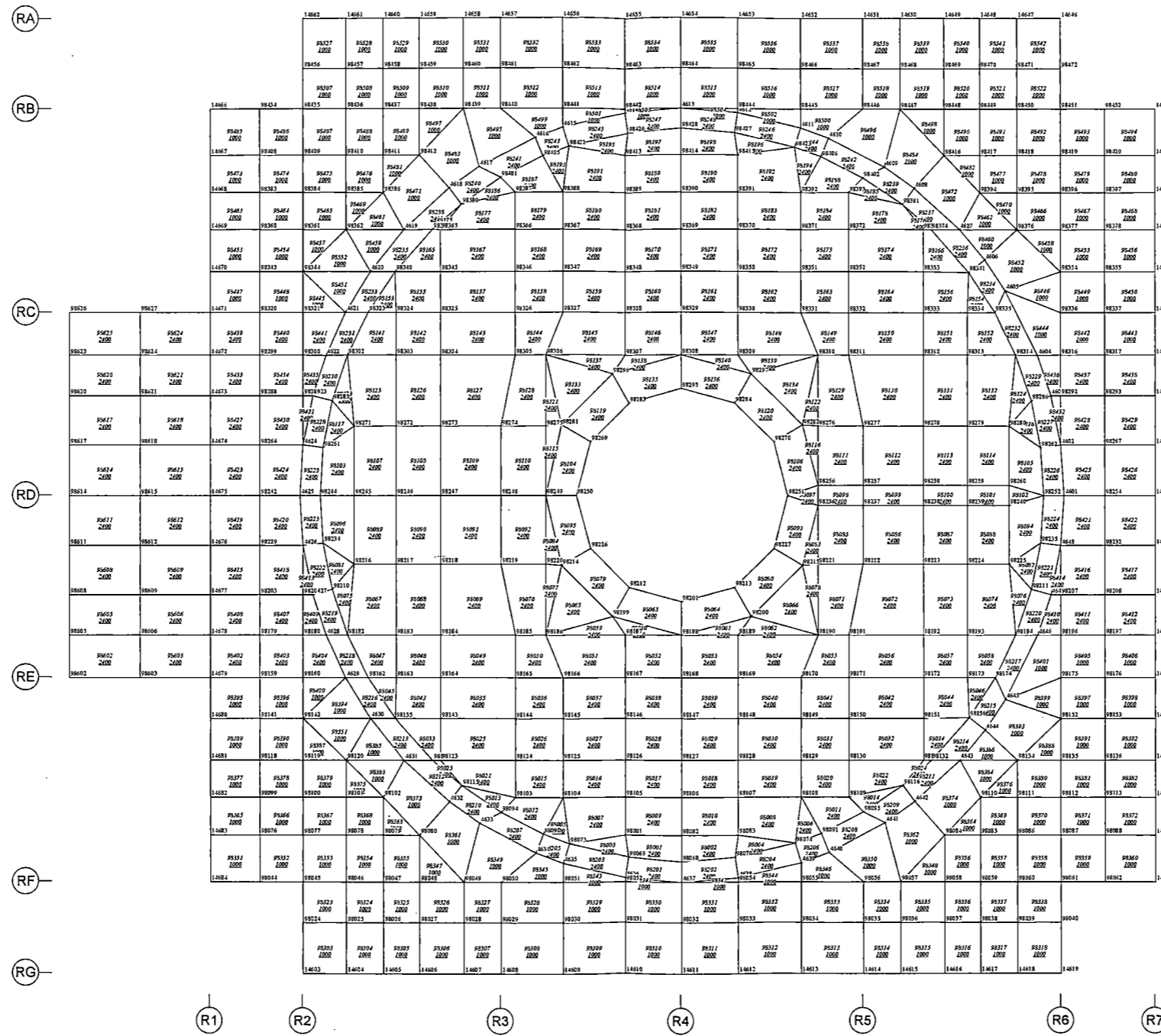

 GRID-ID
 ELEM-ID
 PID

Figure 6.2-29 FE Model of the Slab at EL 17,500


Figure 6.2-30 FE Model of the Slab at EL 27,000

 GRID-ID
 ELEM-ID
 PID

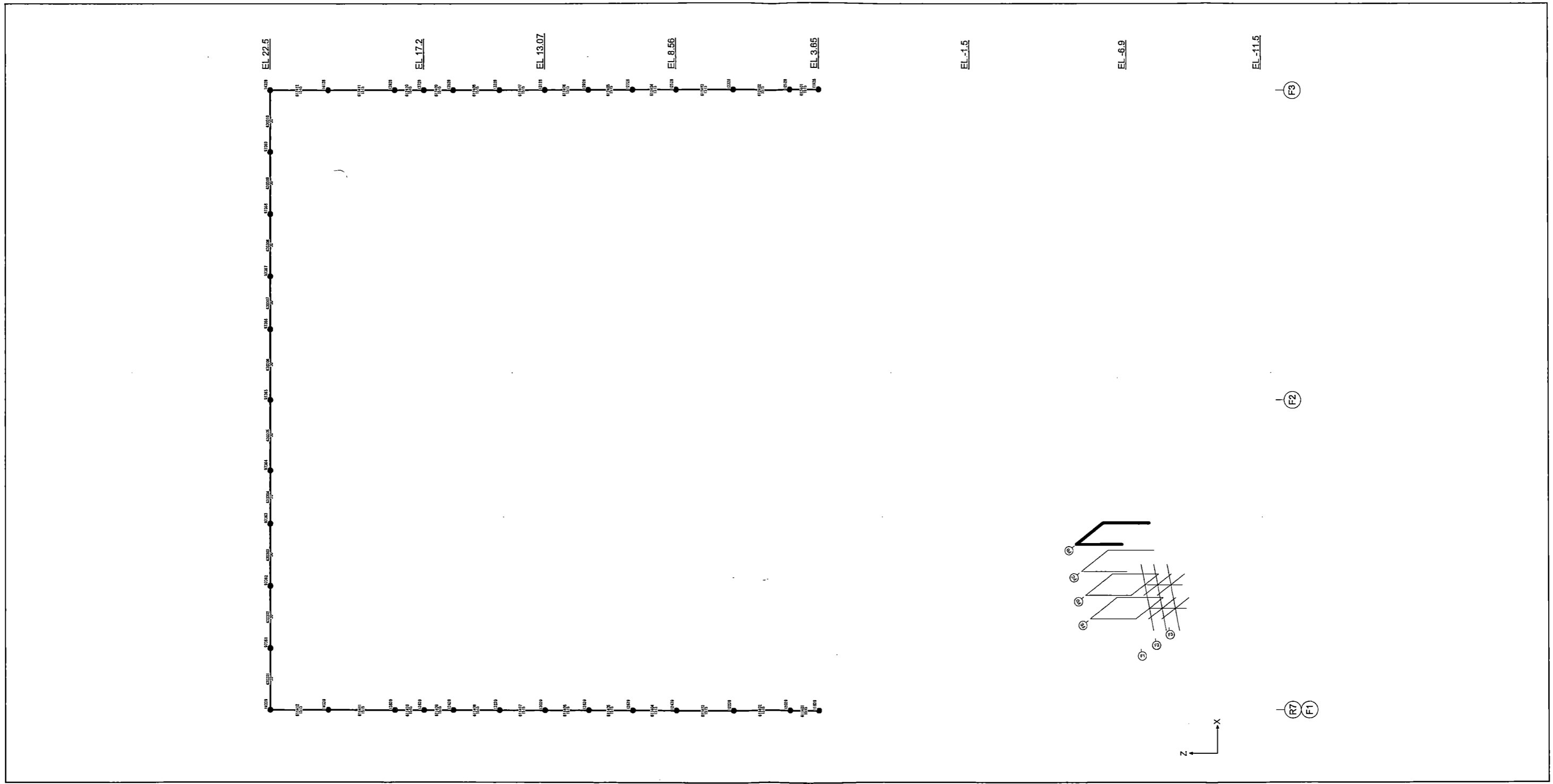


Figure 6.2.2-31 FE Model of the FB Frame (FB Column Line)

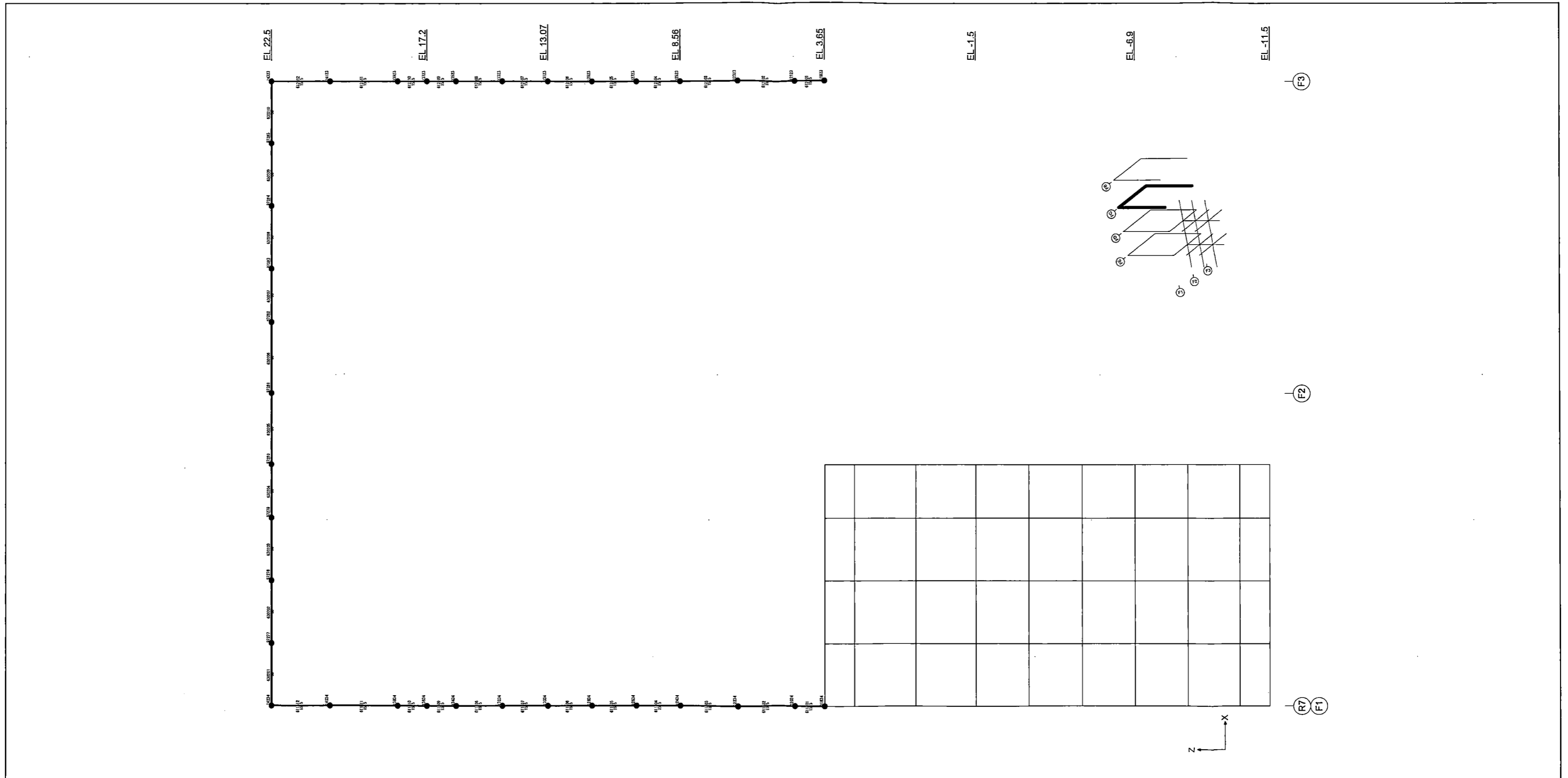


Figure 6.2.2-32 FE Model of the FB Frame (FC Column Line)

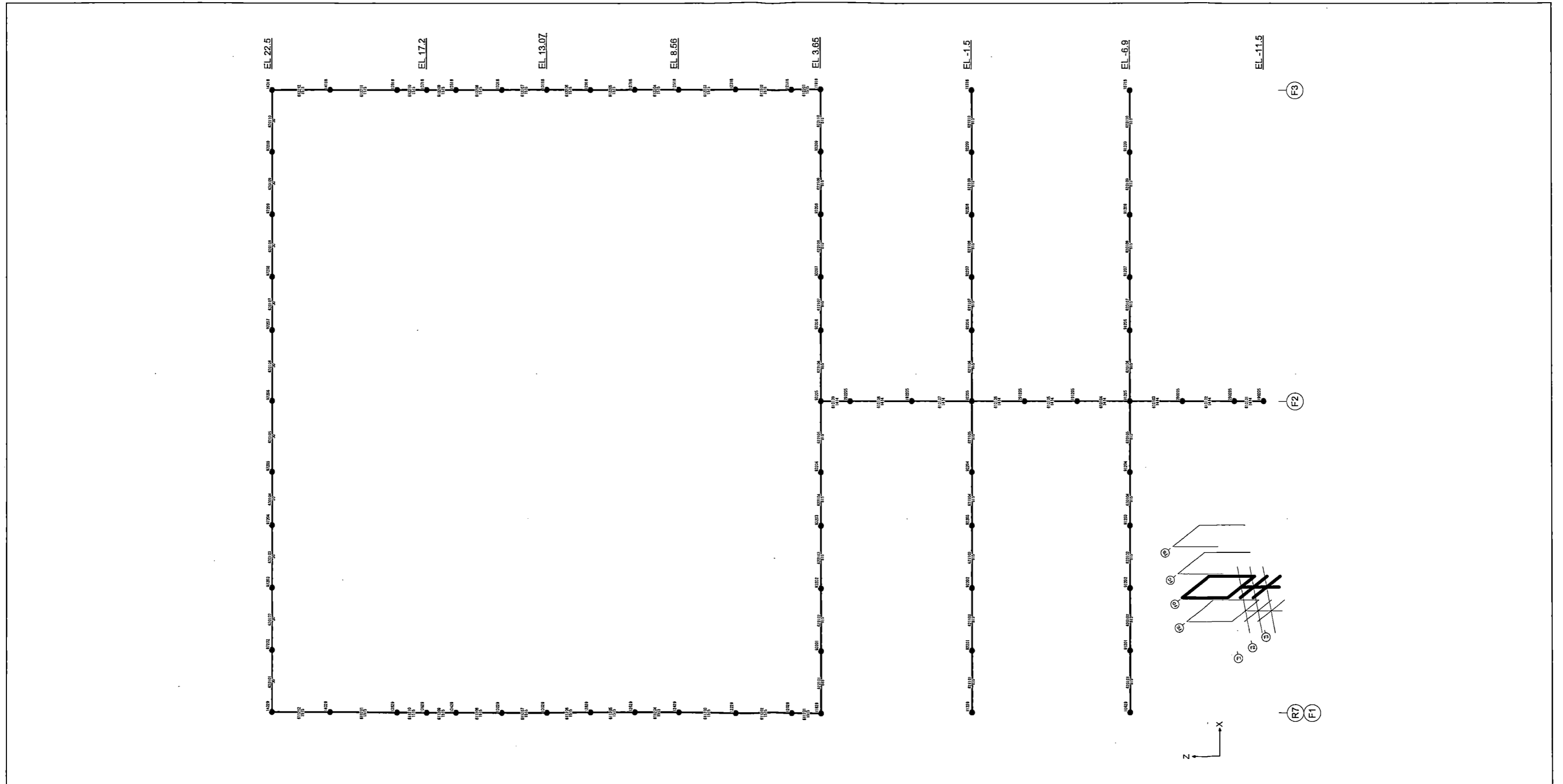


Figure 6.2.2-33 FE Model of the FB Frame (FD Column Line)

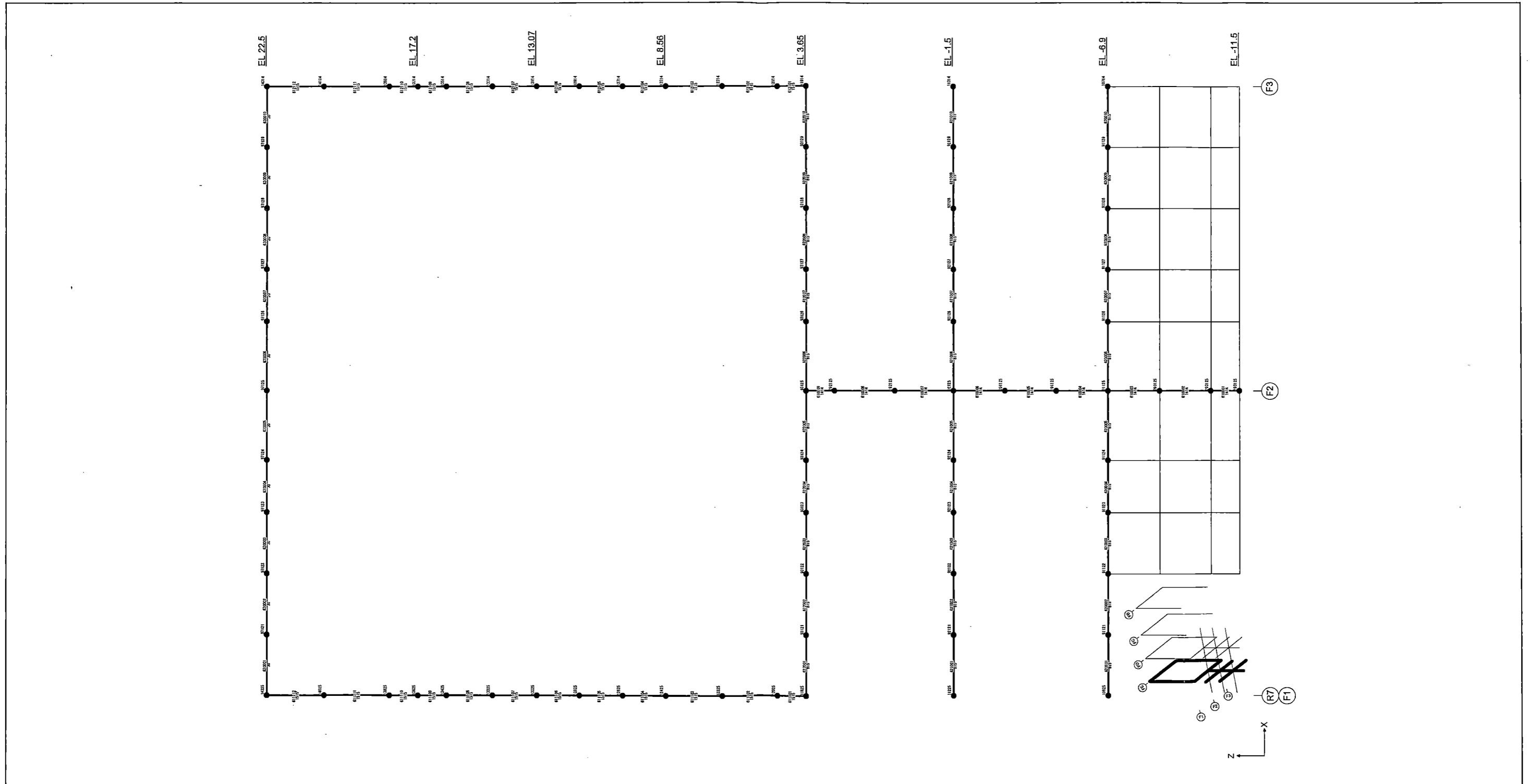
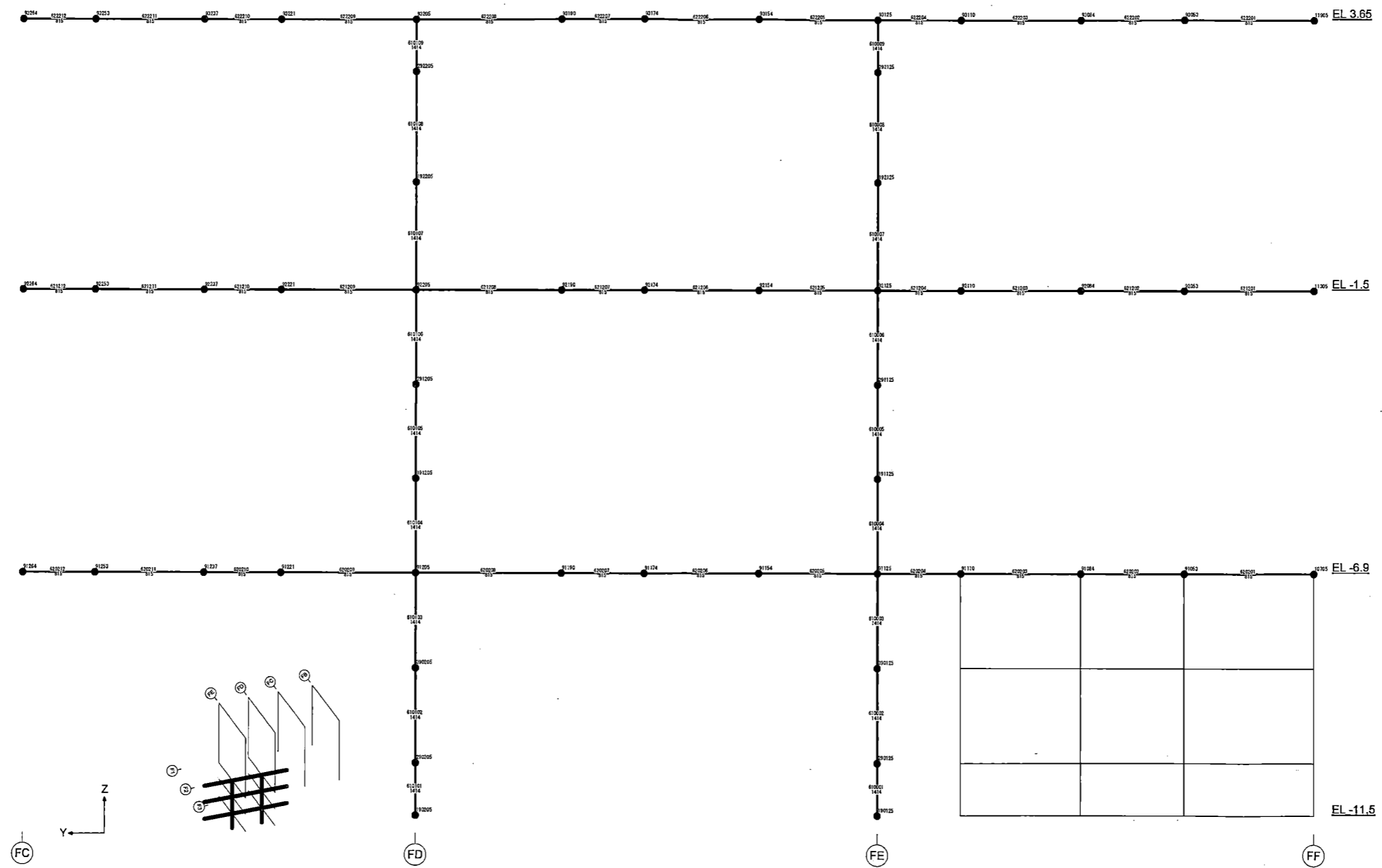


Figure 6.2.2-34 FE Model of the FB Frame (FE Column Line)



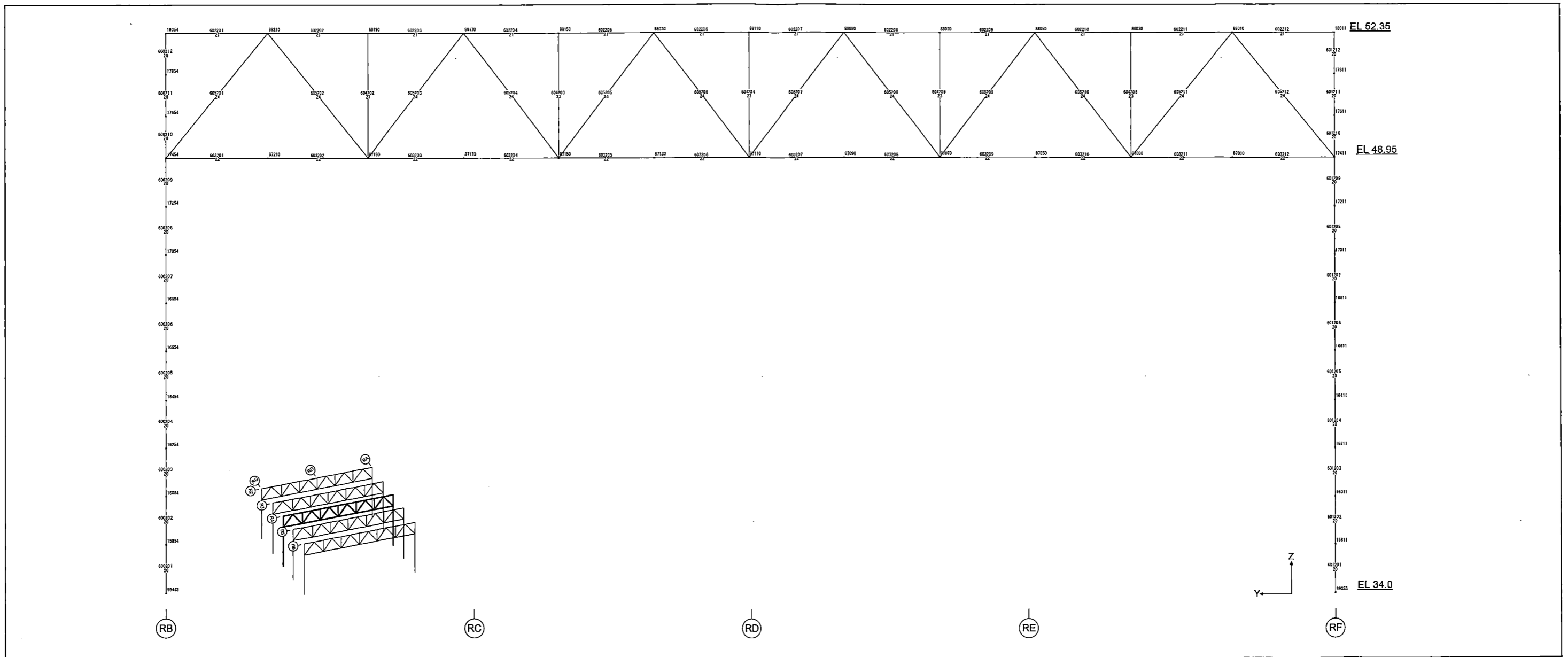


Figure 6.2.2-36 FE Model of the Roof Truss (R4 Column Line)



HITACHI

WG3-U71-ERD-S-0004 SH NO. 292

REV. 0

of 538

{

}

Figure 6.2.3.1-1 Equipment Loads at EL -11,500

{{{Contains Security-Related Information – Withheld Under 10 CFR 2.390.}}}



HITACHI

WG3-U71-ERD-S-0004 SH NO. 293

REV. 0

of 538

{

}

Figure 6.2.3.1-2 Equipment Loads at EL -6,400

{{{Contains Security-Related Information – Withheld Under 10 CFR 2.390.}}}



HITACHI

WG3-U71-ERD-S-0004 SH NO. 294
REV. 0 of 538

{

}

Figure 6.2.3.1-3 Equipment Loads at EL -1,000

{{{Contains Security-Related Information – Withheld Under 10 CFR 2.390.}}}



HITACHI

WG3-U71-ERD-S-0004 SH NO. 295
REV. 0 of 538

{

}

Figure 6.2.3.1-4 Equipment Loads at EL 4,650

{{{Contains Security-Related Information – Withheld Under 10 CFR 2.390.}}}



HITACHI

WG3-U71-ERD-S-0004 SH NO. 296
REV. 0 of 538

{

}

Figure 6.2.3.1-5 Equipment Loads at EL 9,060

{{{Contains Security-Related Information -- Withheld Under 10 CFR 2.390.}}}



HITACHI

WG3-U71-ERD-S-0004 SH NO. 297
REV. 0 of 538

{

}

Figure 6.2.3.1-6 Equipment Loads at EL 13,570

{{{Contains Security-Related Information – Withheld Under 10 CFR 2.390}}}



HITACHI

WG3-U71-ERD-S-0004 SH NO. 298
REV. 0 of 538

{

}

Figure 6.2.3.1-7 Equipment Loads at EL 22,500

{{{Contains Security-Related Information – Withheld Under 10 CFR 2.390.}}}



HITACHI

WG3-U71-ERD-S-0004 SH NO. 299

REV. 0

of 538

{

}

Figure 6.2.3.1-8 Equipment Loads at EL 27,000

{{{Contains Security-Related Information – Withheld Under 10 CFR 2.390.}}}



HITACHI

WG3-U71-ERD-S-0004 SH NO. 300
REV. 0 of 538

{

}

Figure 6.2.3.1-9 Equipment Loads at EL 34,000

{{{Contains Security-Related Information – Withheld Under 10 CFR 2.390.}}}



HITACHI

WG3-U71-ERD-S-0004 SH NO. 301

REV. 0

of 538

{

}

Figure 6.2.3.1-10 Equipment Loads above EL 34,000

{{{Contains Security-Related Information – Withheld Under 10 CFR 2.390.}}}



HITACHI

WG3-U71-ERD-S-0004 SH NO. 302
REV. 0 of 538

{

}

Figure 6.2.3.1-11 Hydrostatic Loads on the Basemat

{{{Contains Security-Related Information – Withheld Under 10 CFR 2.390.}}}



HITACHI

WG3-U71-ERD-S-0004 SH NO. 303
REV. 0 of 538

{

}

Figure 6.2.3.1-12 Hydrostatic Loads on the Slab at EL -1,000

{{{Contains Security-Related Information – Withheld Under 10 CFR 2.390.}}}

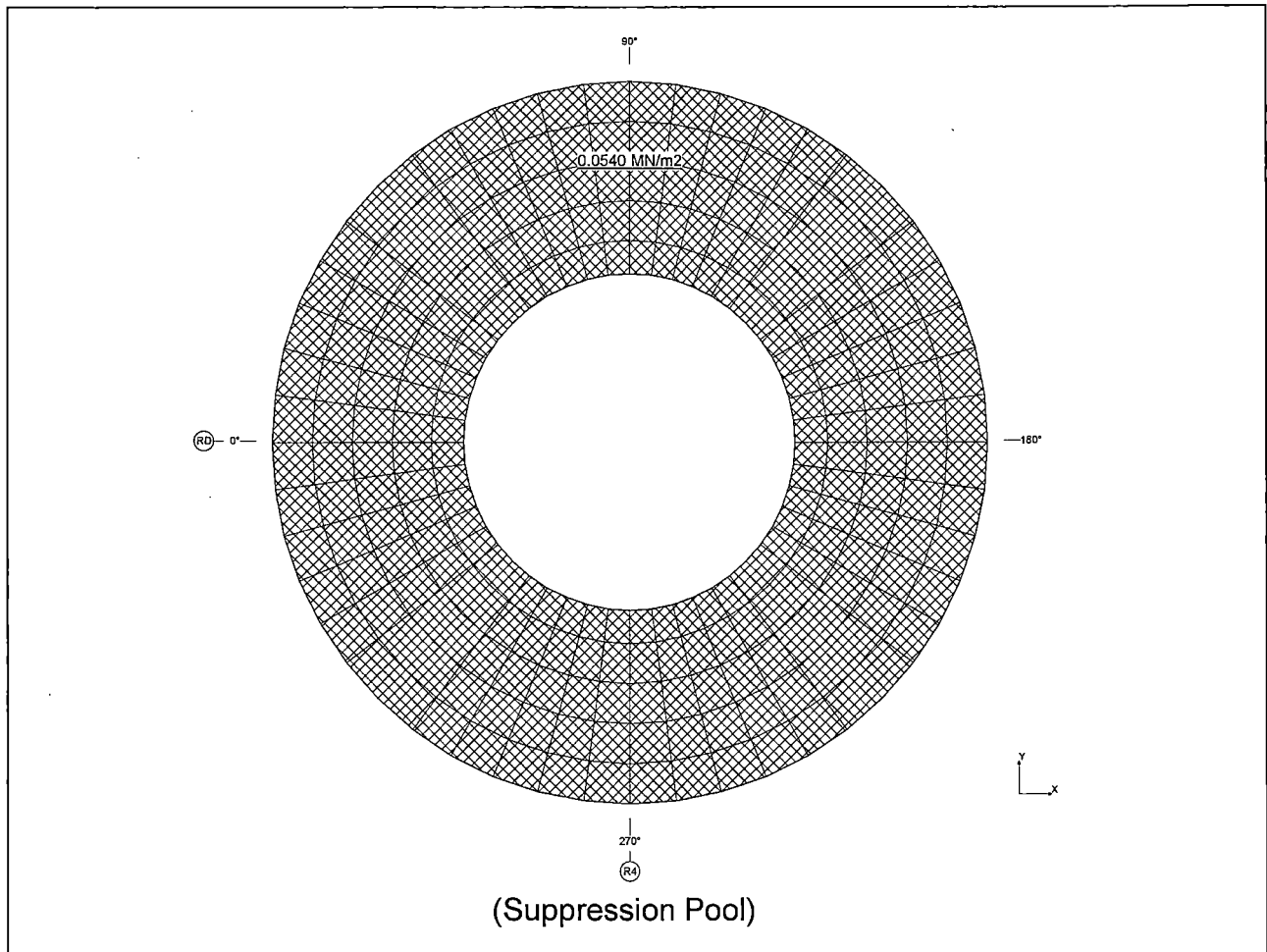


Figure 6.2.3.1-13 Hydrostatic Loads on the Suppression Pool Floor Liner



HITACHI

WG3-U71-ERD-S-0004 SH NO. 305
REV. 0 of 538

{

}

Figure 6.2.3.1-14 Hydrostatic Loads on the Slab at EL 27,000

{{{Contains Security-Related Information – Withheld Under 10 CFR 2.390.}}}

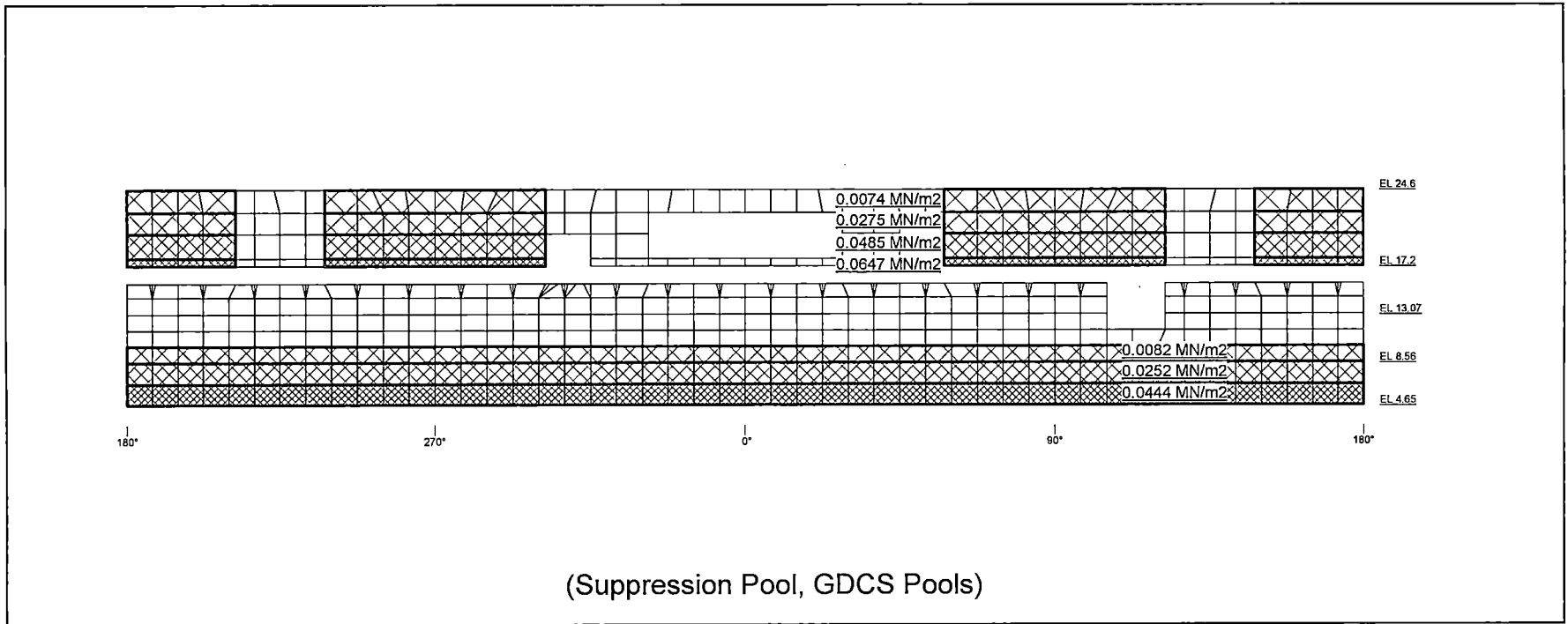


Figure 6.2.3.1-15 Hydrostatic Loads on the RCCV Wall Liner



HITACHI

WG3-U71-ERD-S-0004

SH NO. 307

REV. 0

of 538

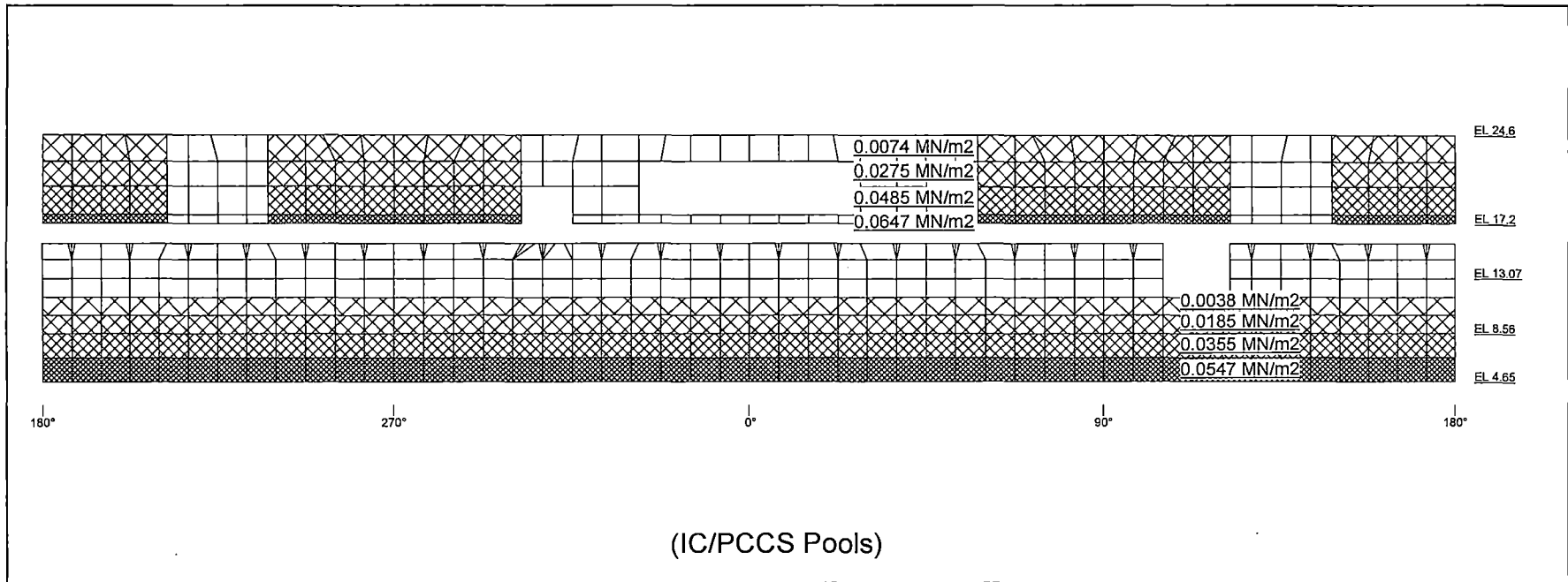


Figure 6.2.3.1-16 Hydrostatic Loads during LOCA Flooding on the RPV Pedestal Liner

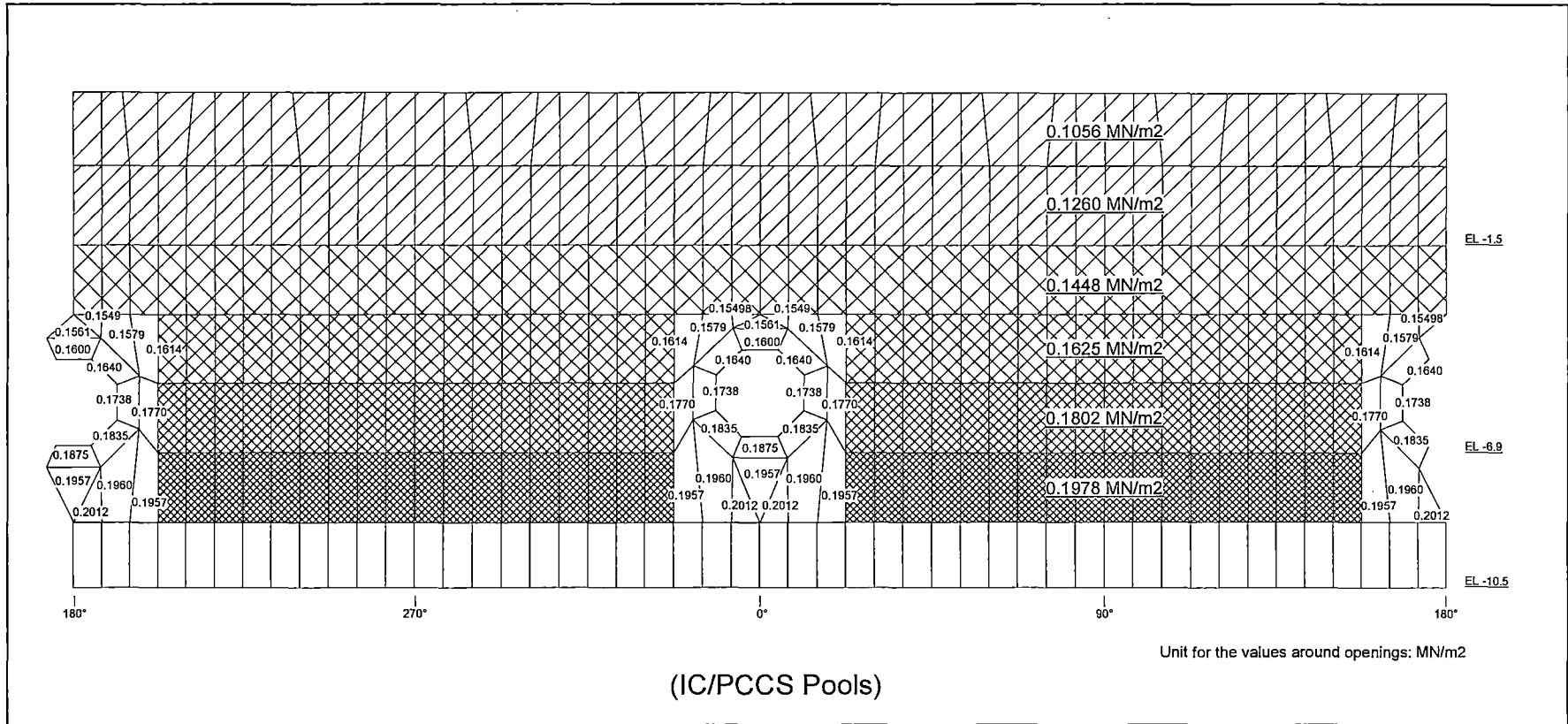


Figure 6.2.3.1-17 Hydrostatic Loads during LOCA Flooding on the RCCV Liner

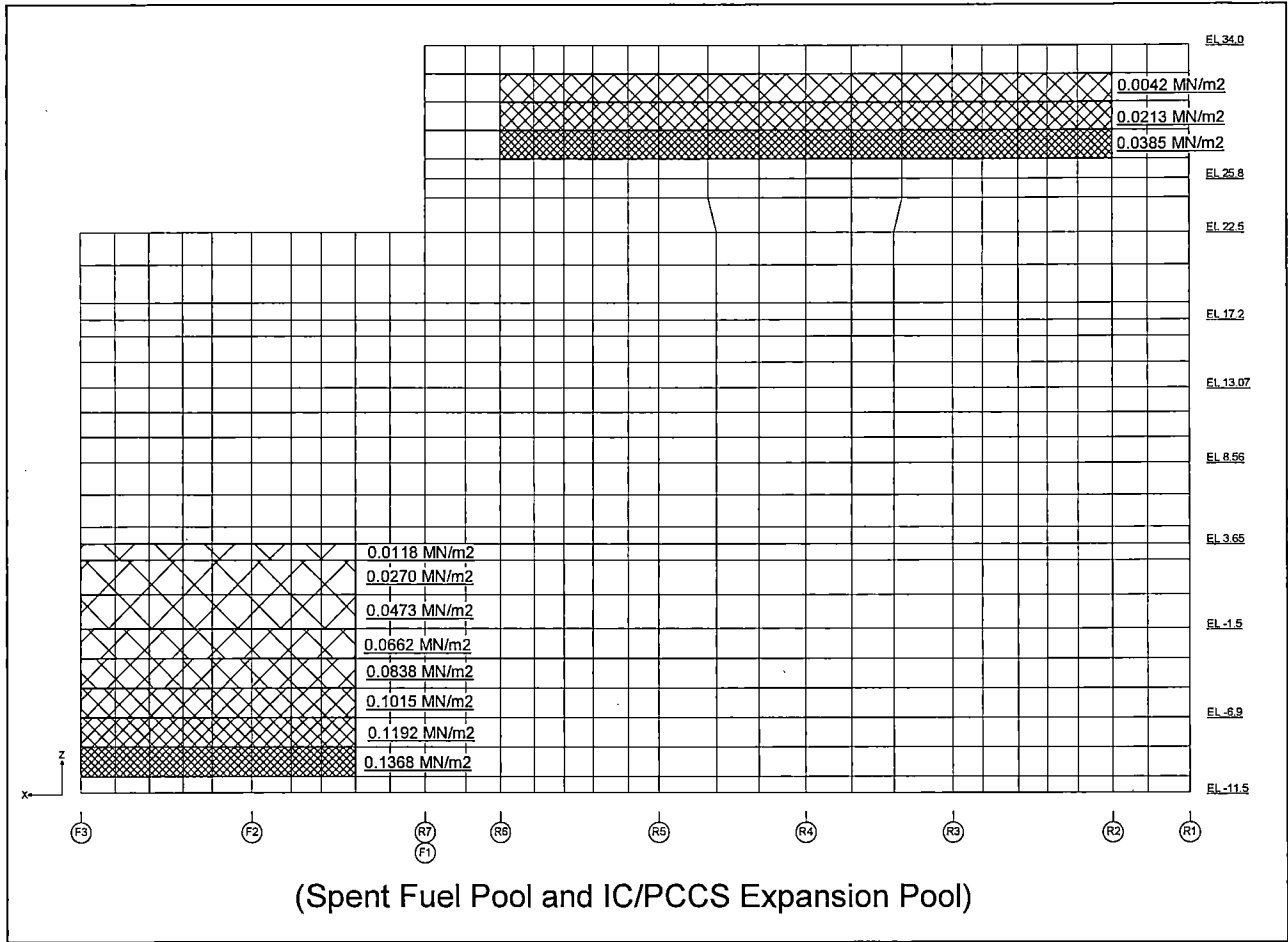


Figure 6.2.3.1-18 Hydrostatic Loads on the RA FA External Wall

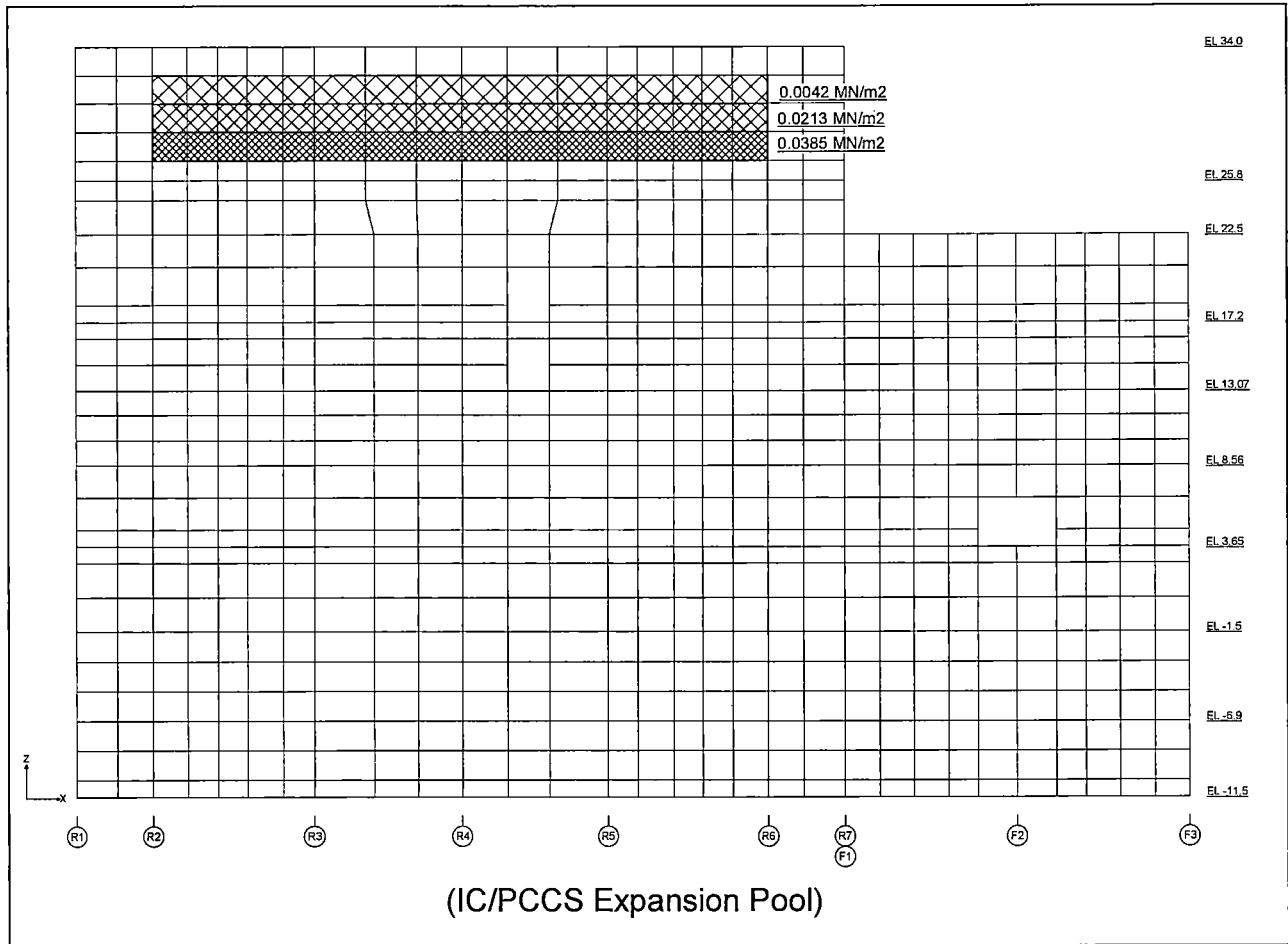


Figure 6.2.3.1-19 Hydrostatic Loads on the RG/FF External Wall

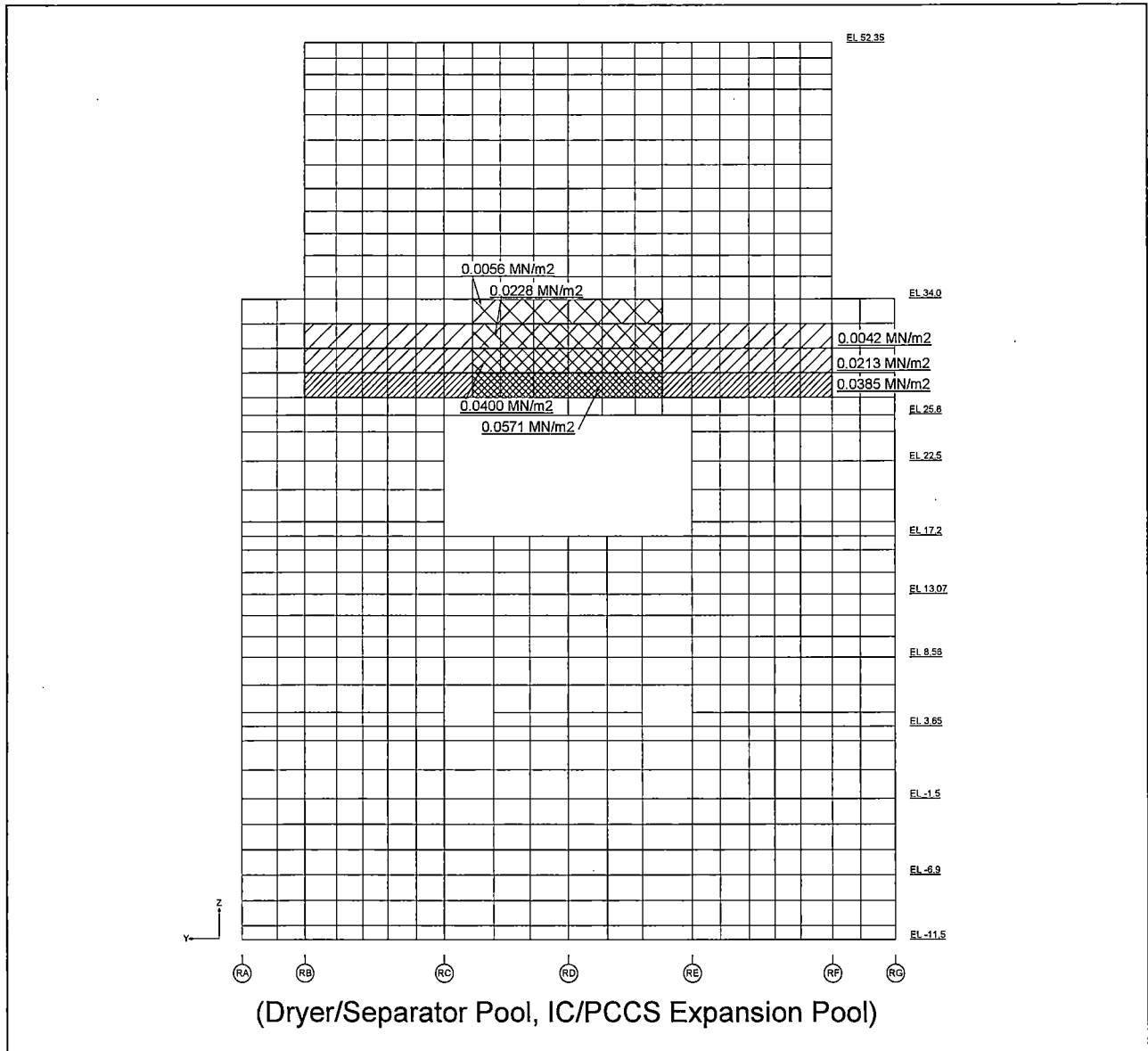


Figure 6.2.3.1-20 Hydrostatic Loads on the R1 External Wall

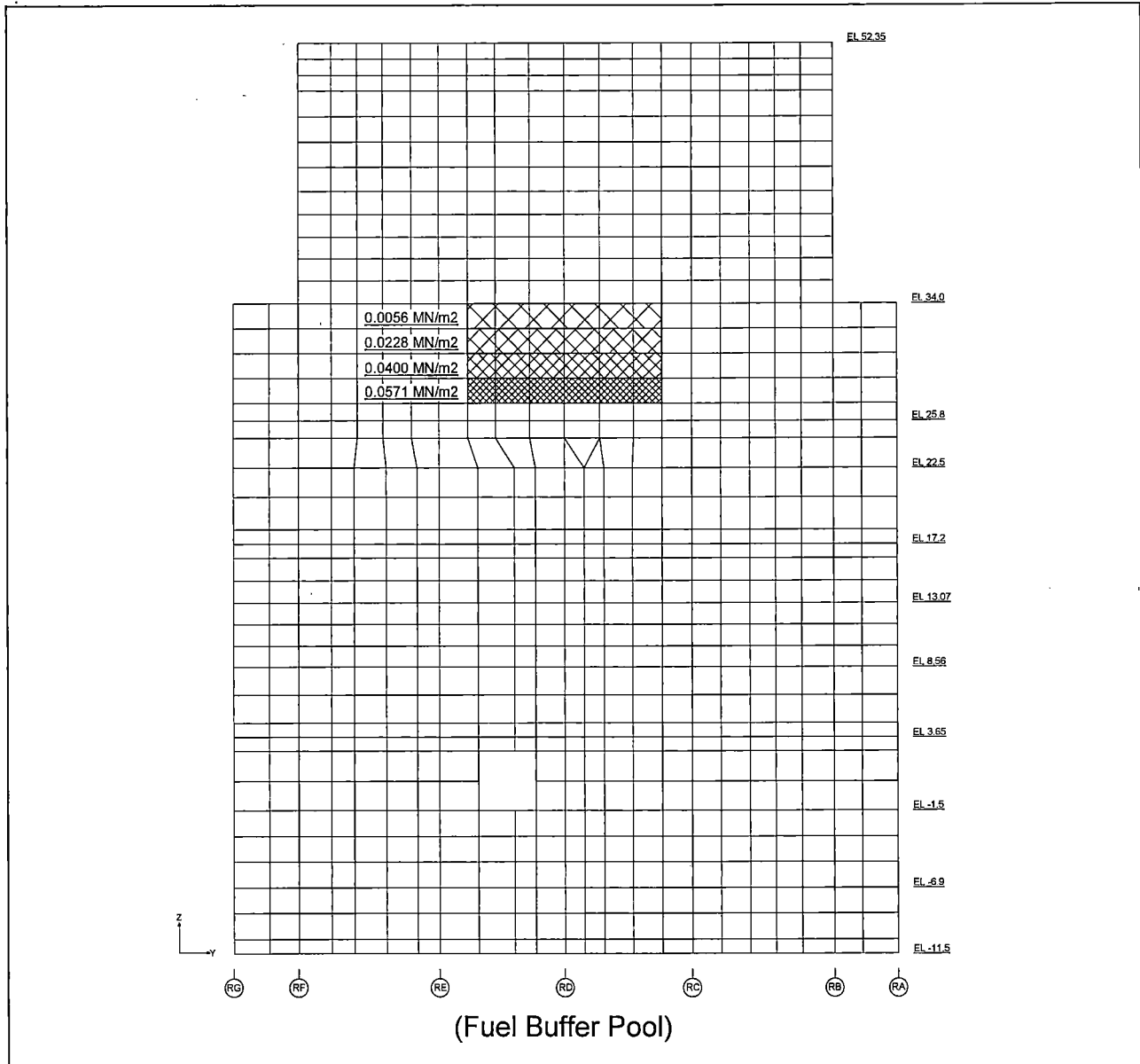


Figure 6.2.3.1-21 Hydrostatic Loads on the R7/F1 External Wall

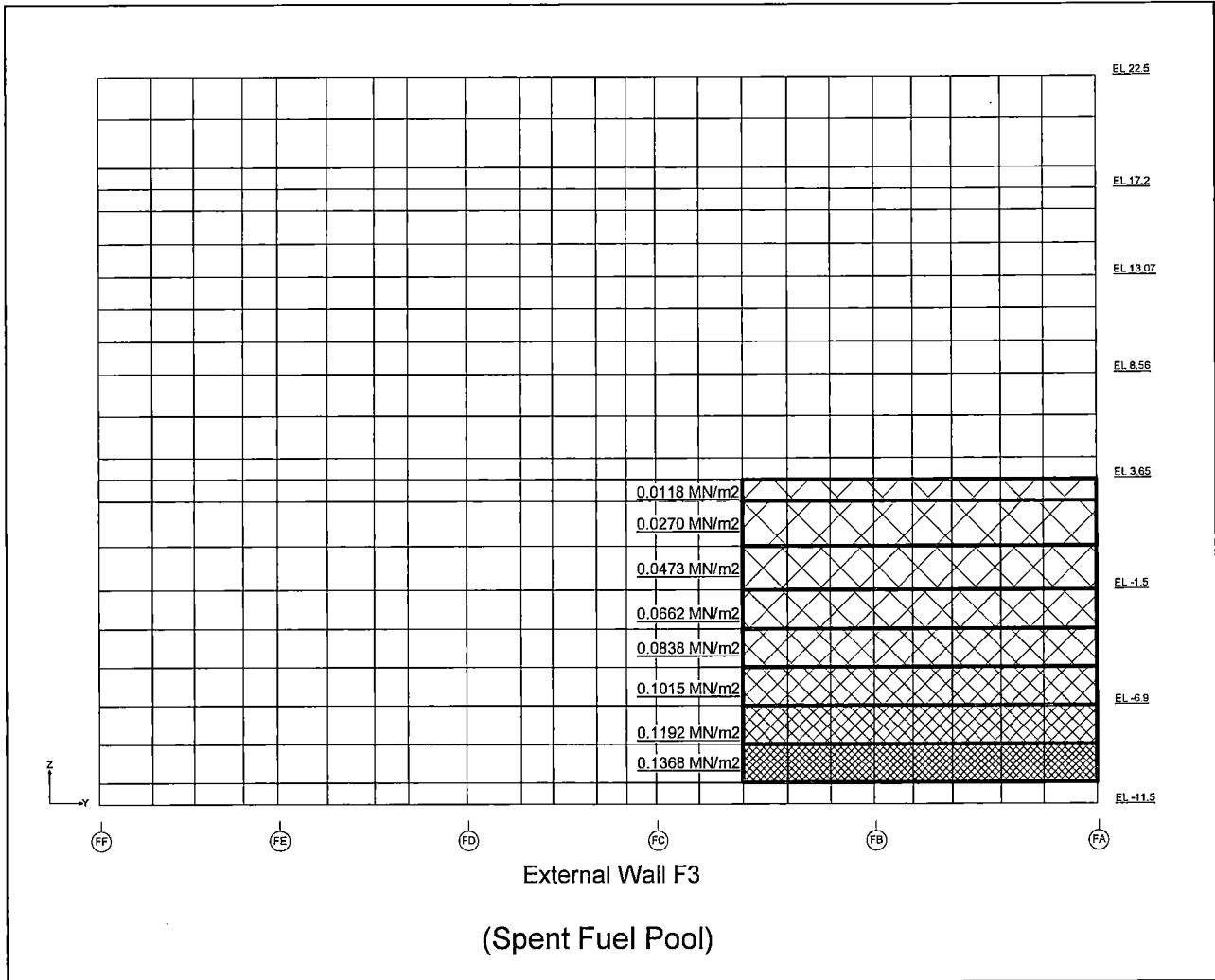


Figure 6.2.3.1-22 Hydrostatic Loads on the F3 External Wall

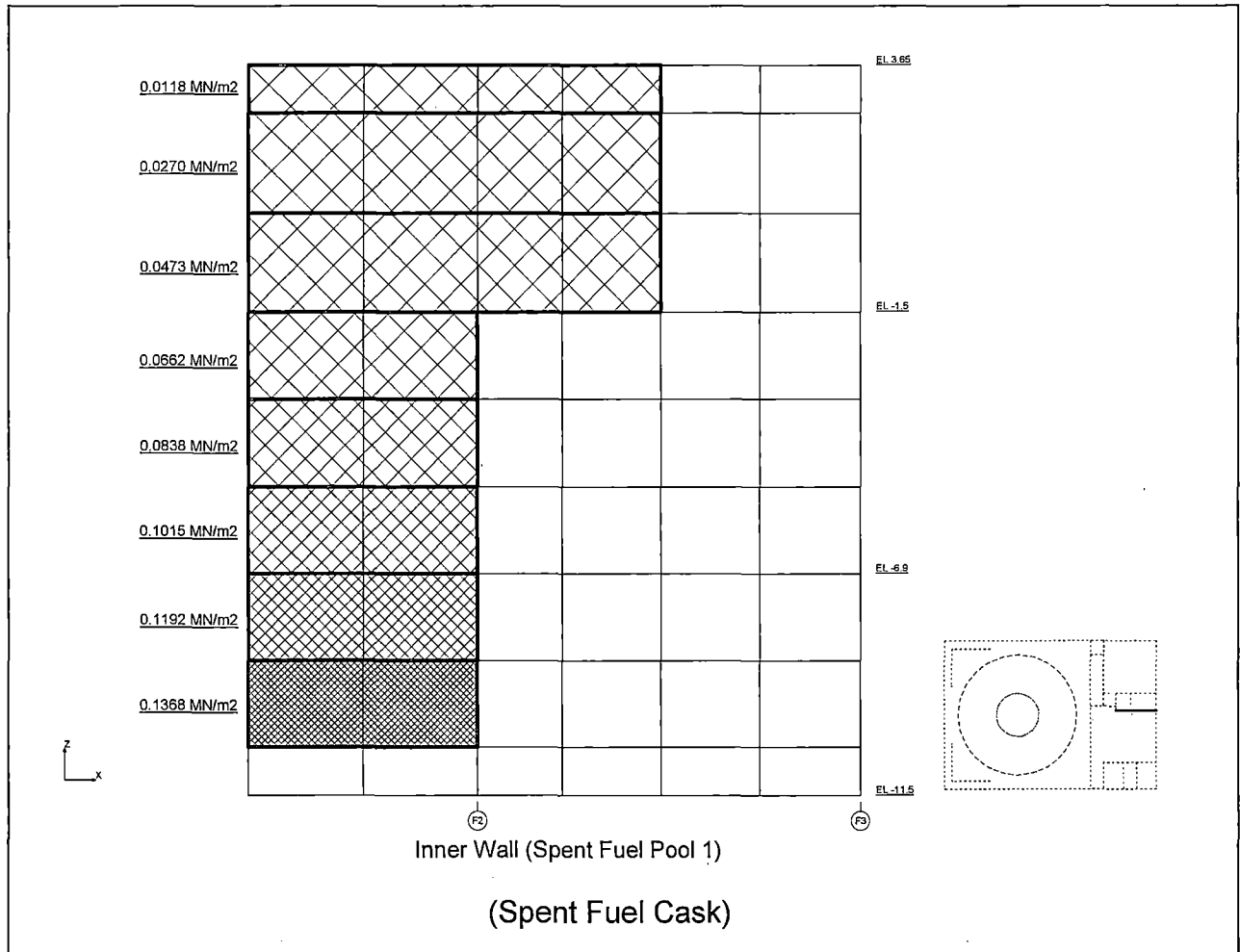


Figure 6.2.3.1-23 Hydrostatic Loads on the Inner Wall at EL -11,500 (1)

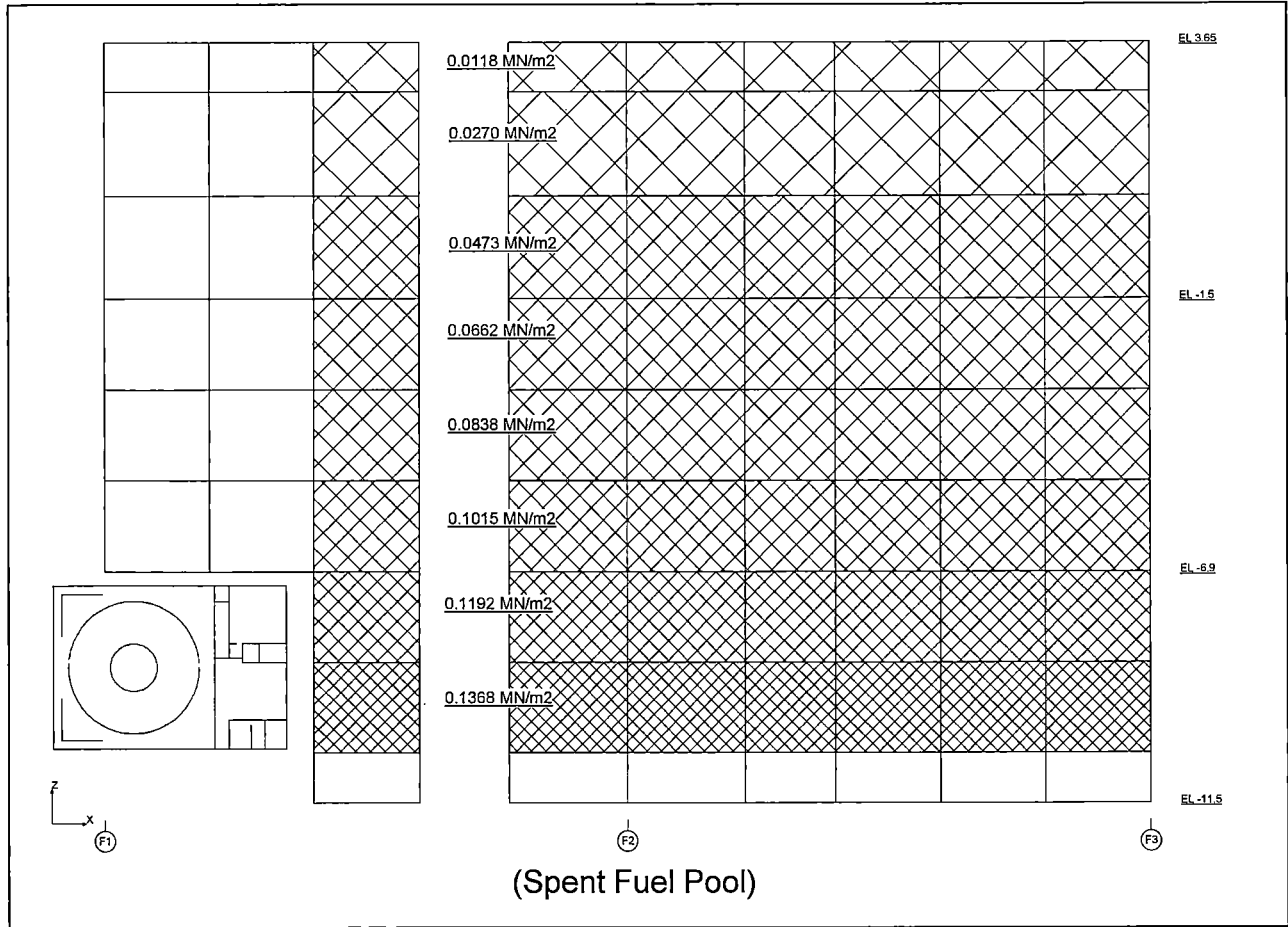


Figure 6.2.3.1-24 Hydrostatic Loads on the Inner Wall at EL -11,500 (2)

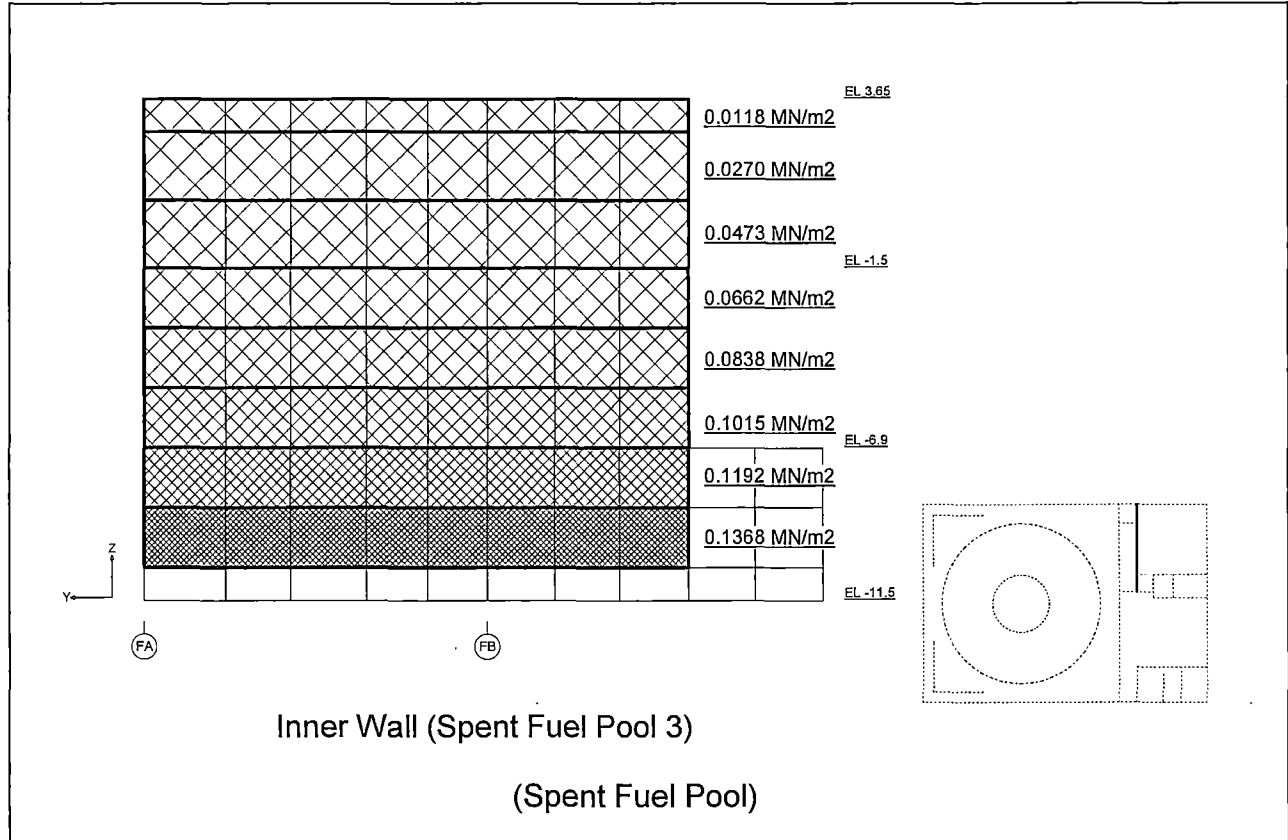


Figure 6.2.3.1-25 Hydrostatic Loads on the Inner Wall at EL -11,500 (3)

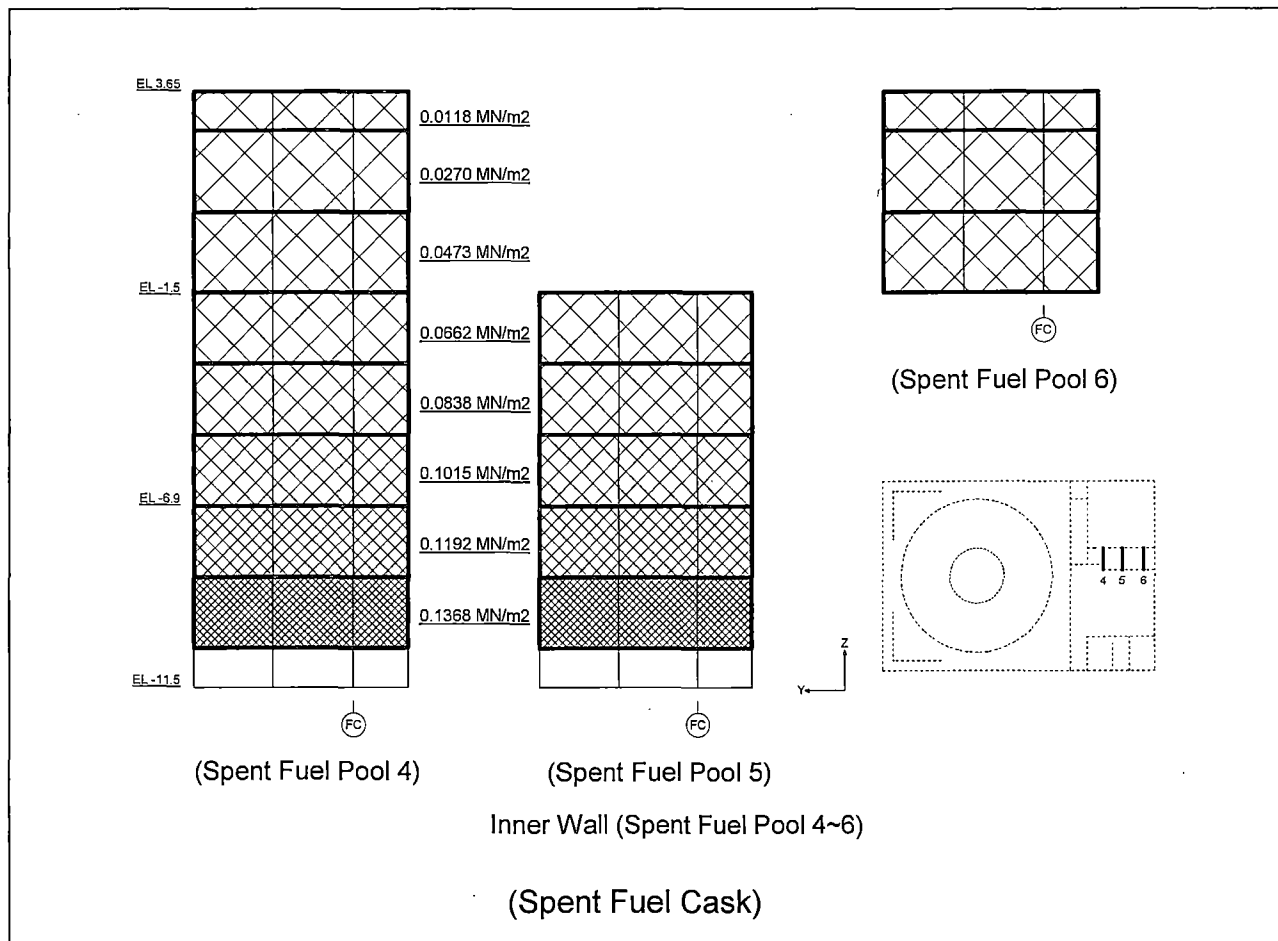


Figure 6.2.3.1-26 Hydrostatic Loads on the Inner Wall at EL -11,500 (4)

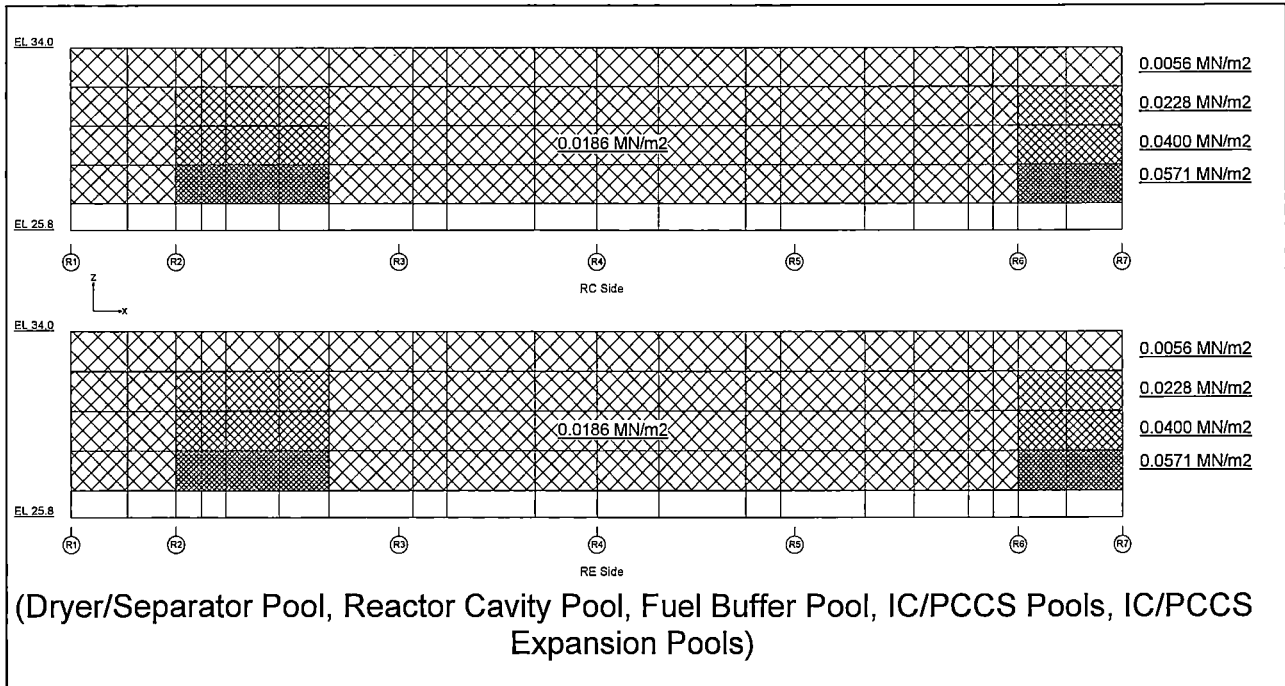


Figure 6.2.3.1-27 Hydrostatic Loads on the Pool Girder

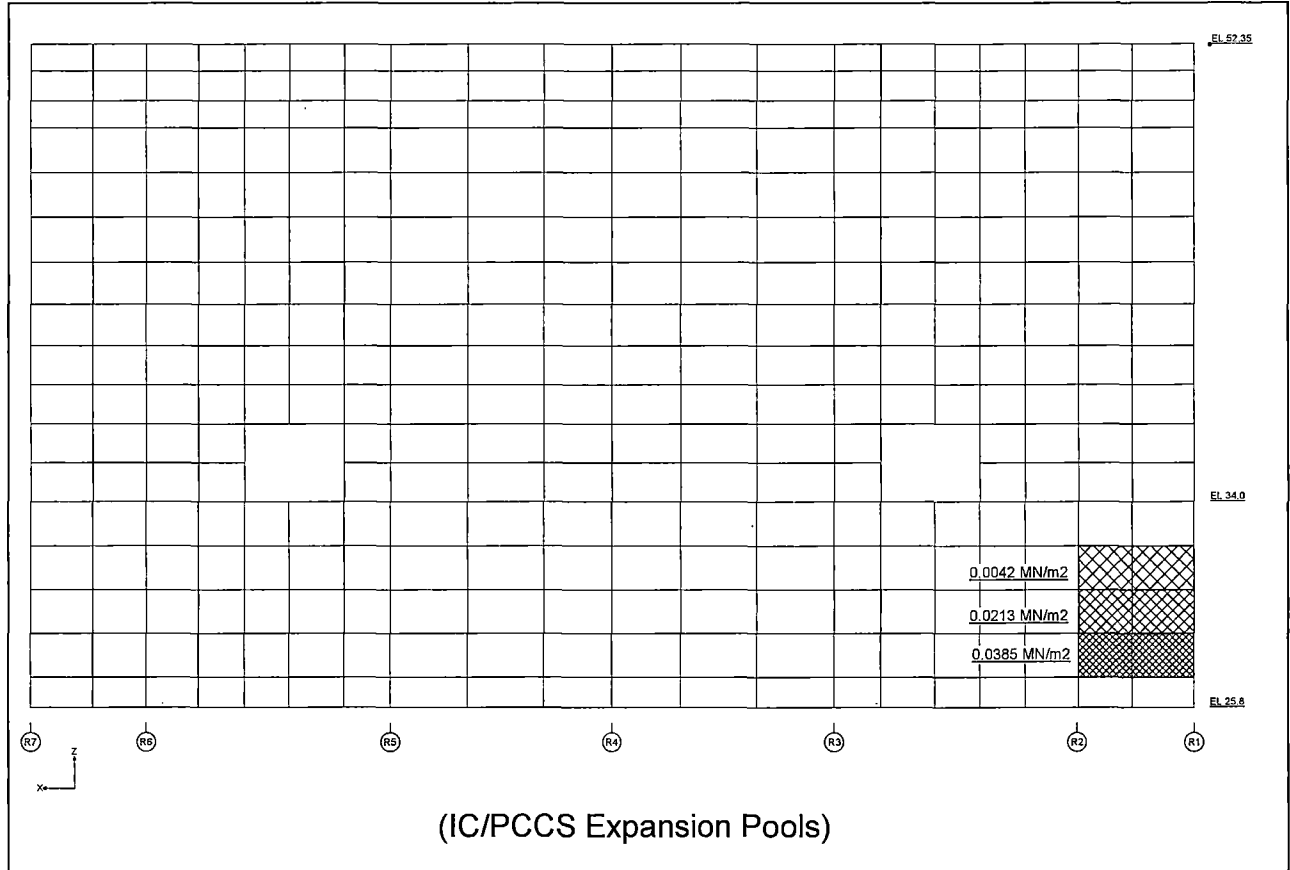


Figure 6.2.3.1-28 Hydrostatic Loads on the Inner Wall at EL 27,000 (RB)

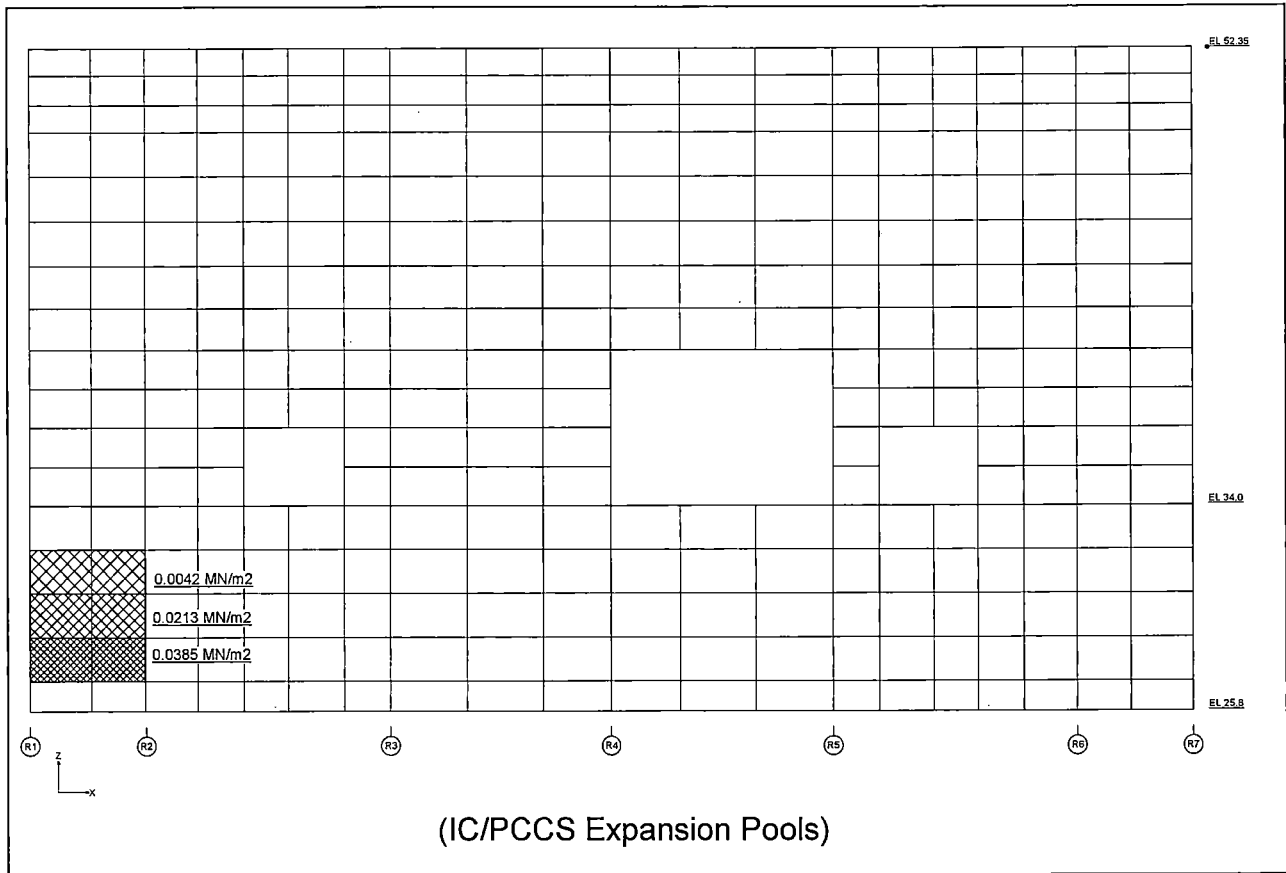


Figure 6.2.3.1-29 Hydrostatic Loads on the Inner Wall at EL 27,000 (RF)

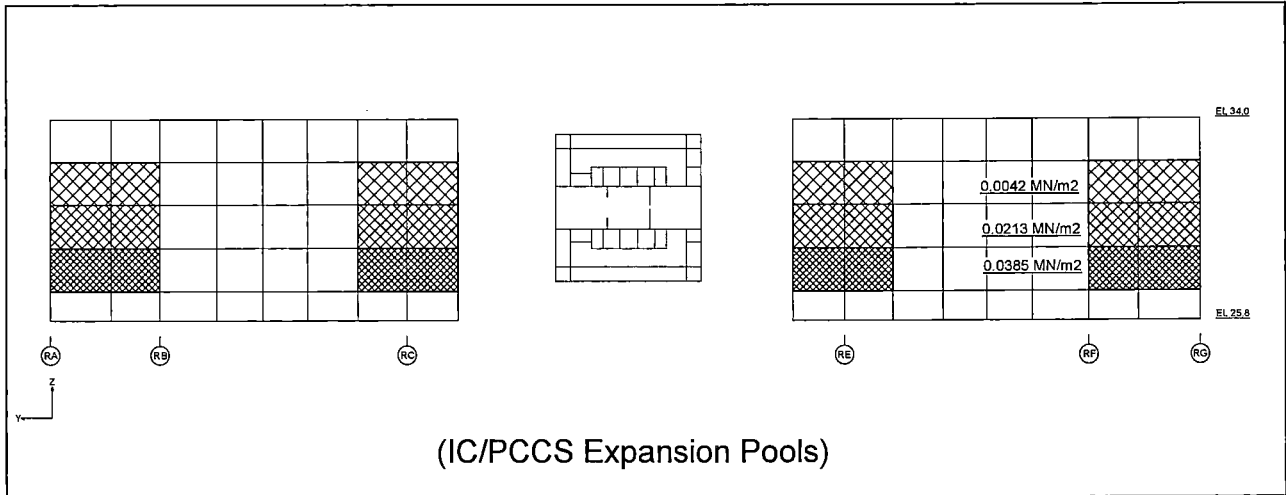


Figure 6.2.3.1-30 Hydrostatic Loads on the Inner Wall at EL 27,000 (R2)

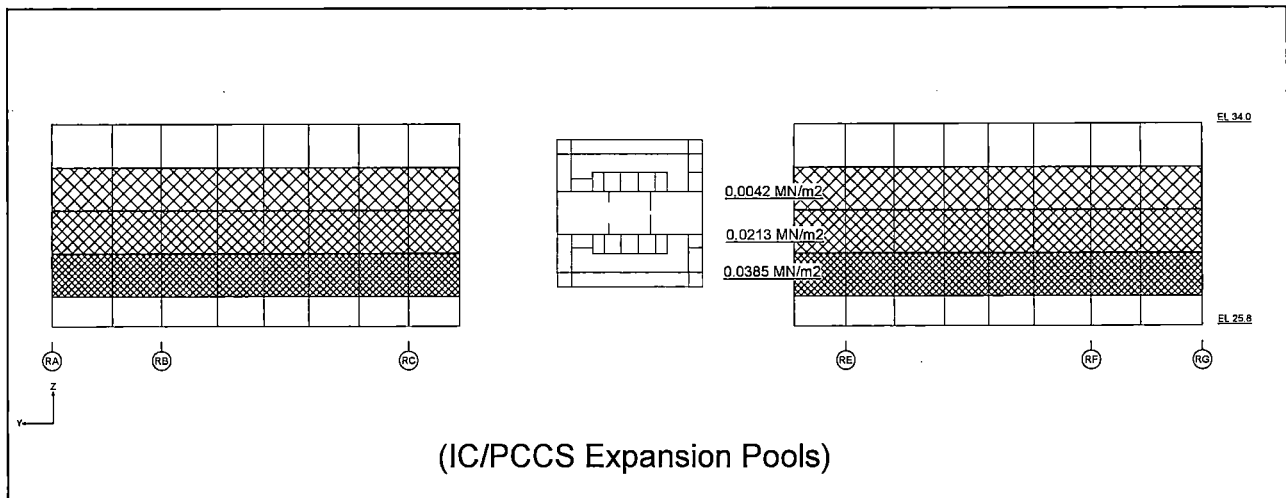


Figure 6.2.3.1-31 Hydrostatic Loads on the Inner Wall at EL 27,000 (R6)

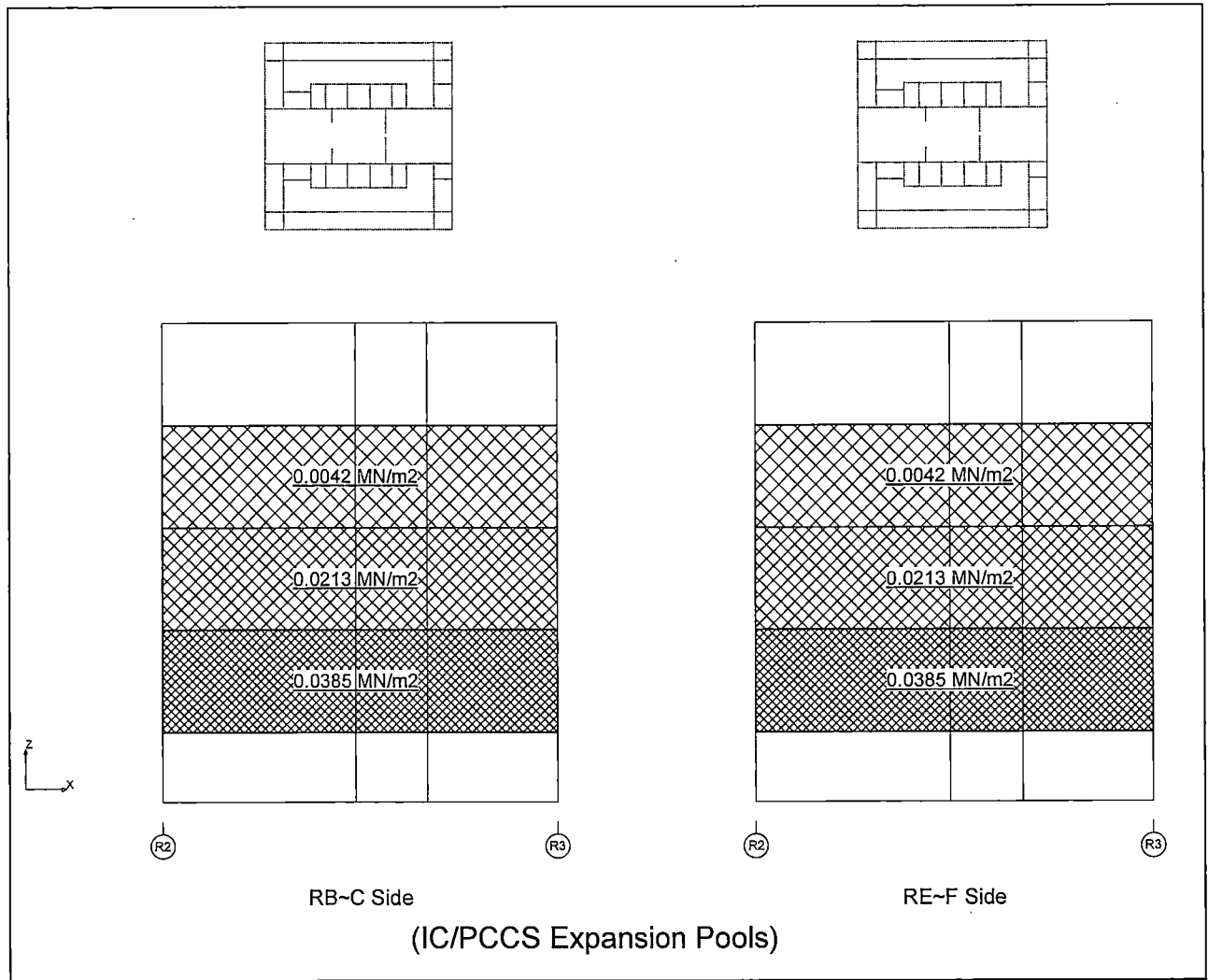


Figure 6.2.3.1-32 Hydrostatic Loads on the Inner Wall at EL 27,000 (1)

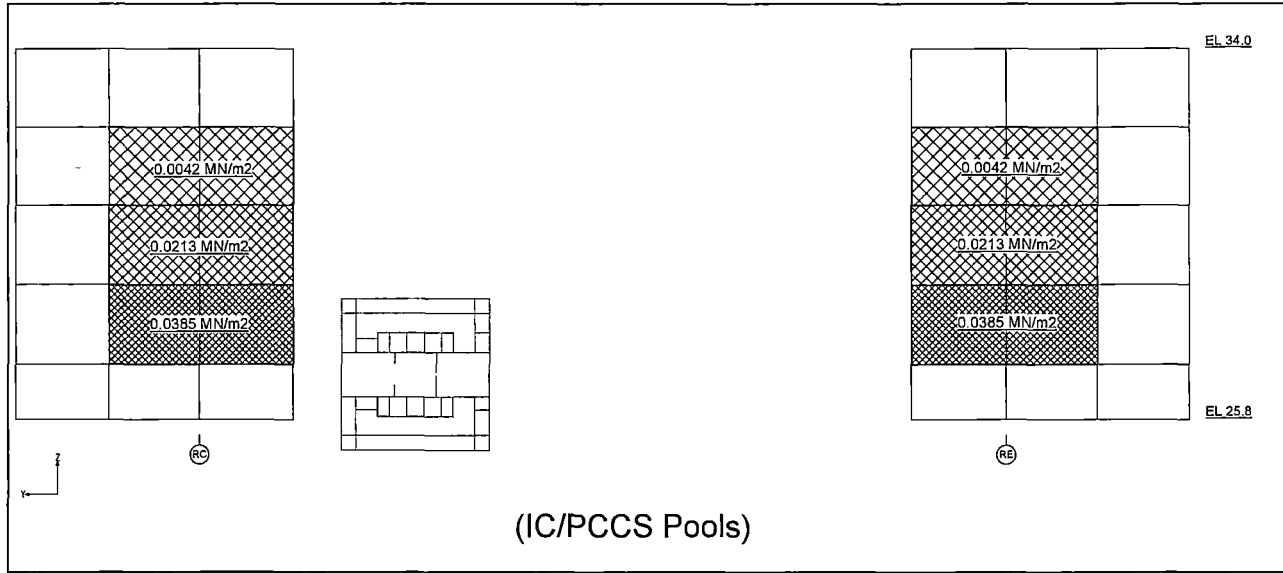


Figure 6.2.3.1-33 Hydrostatic Loads on the Inner Wall at EL 27,000 (2)

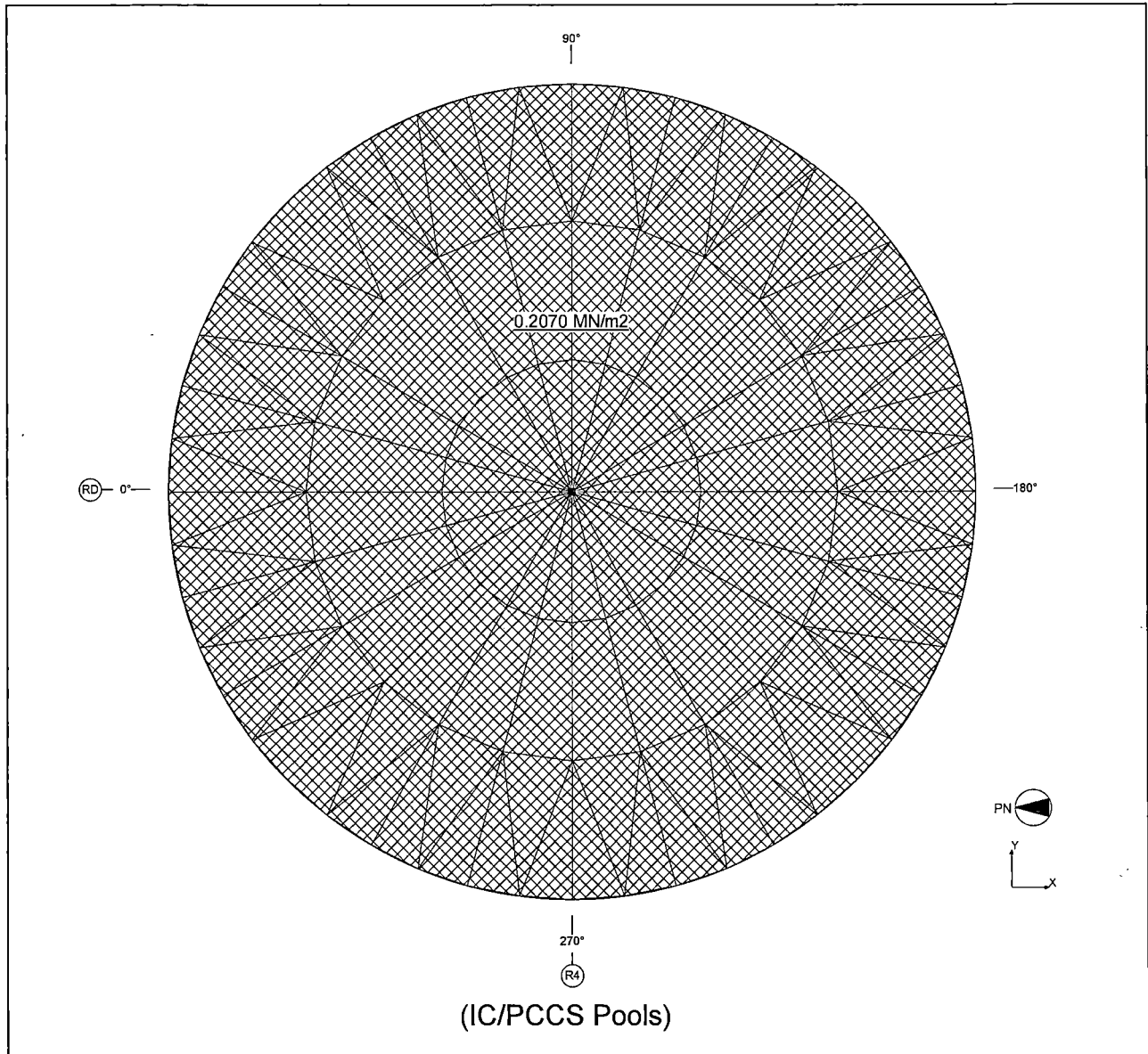


Figure 6.2.3.1-34 Hydrostatic Loads during LOCA Flooding on the Basemat Liner

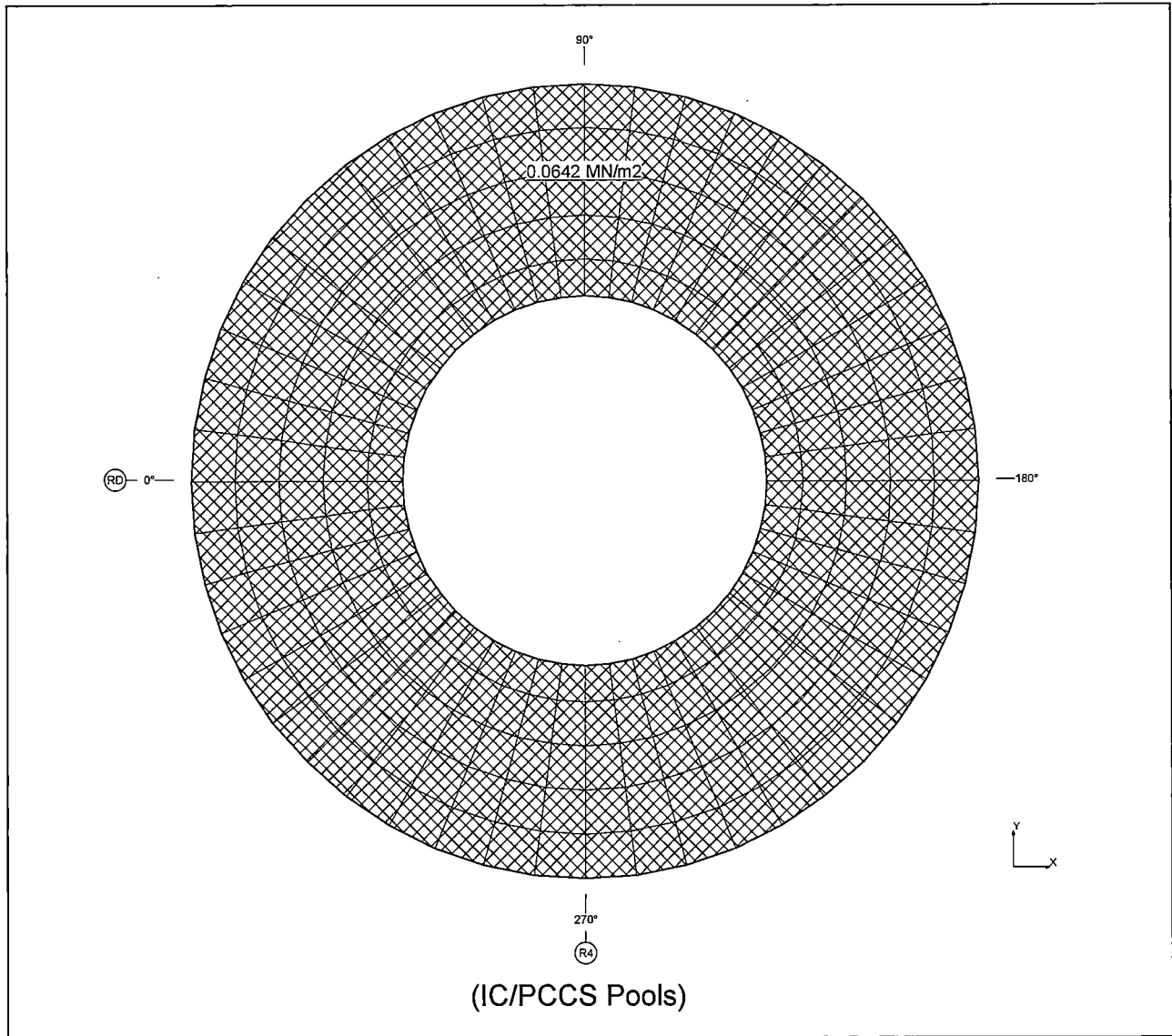


Figure 6.2.3.1-35 Hydrostatic Loads during LOCA Flooding on the Suppression Pool Liner

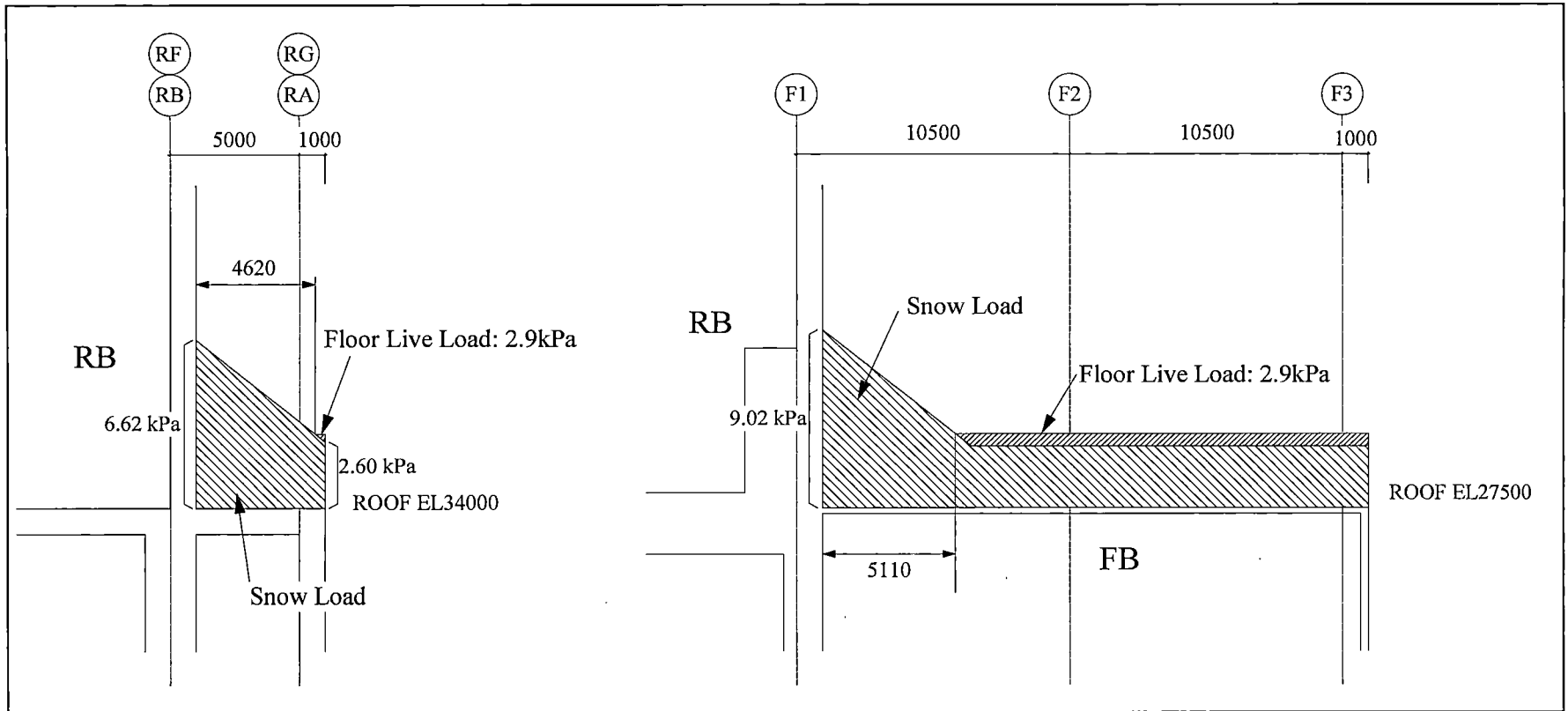


Figure 6.2.3.2-1 Floor Live Load Enveloped Snow Drift Load for Lower Roofs



HITACHI

WG3-U71-ERD-S-0004

SH NO. 327

REV. 0

of 538

{

}

Figure 6.2.3.2-2 Floor Live Load (FB EL 22,500)

{{{Contains Security-Related Information – Withheld Under 10 CFR 2.390.}}}



HITACHI

WG3-U71-ERD-S-0004

SH NO. 328

REV. 0

of 538

{

}

Figure 6.2.3.2-3 Lateral Soil Pressure Load at Rest (Basemat)

{{{Contains Security-Related Information – Withheld Under 10 CFR 2.390.}}}

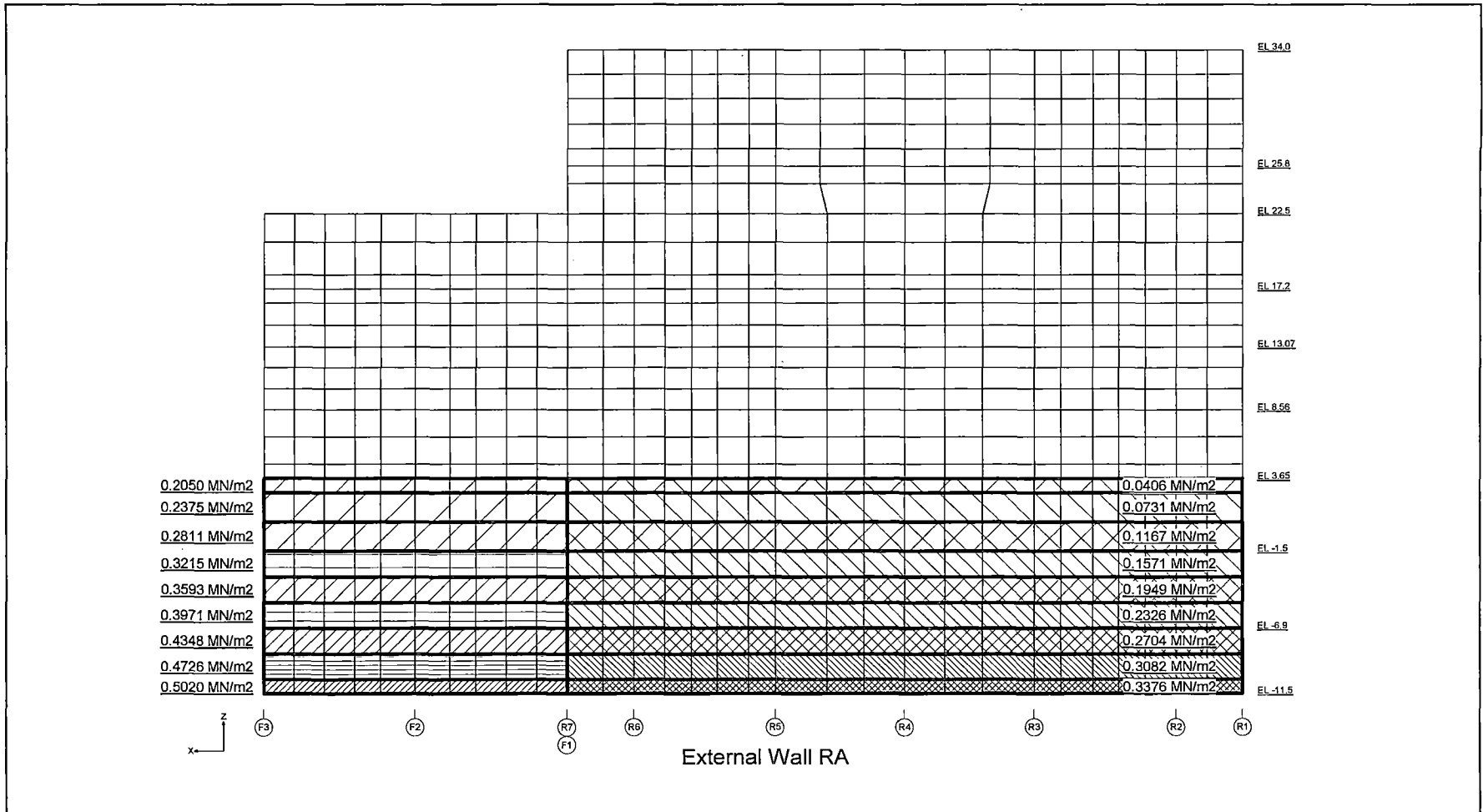


Figure 6.2.3.2-4 Lateral Soil Pressure Load at Rest (RA/FA External Wall)

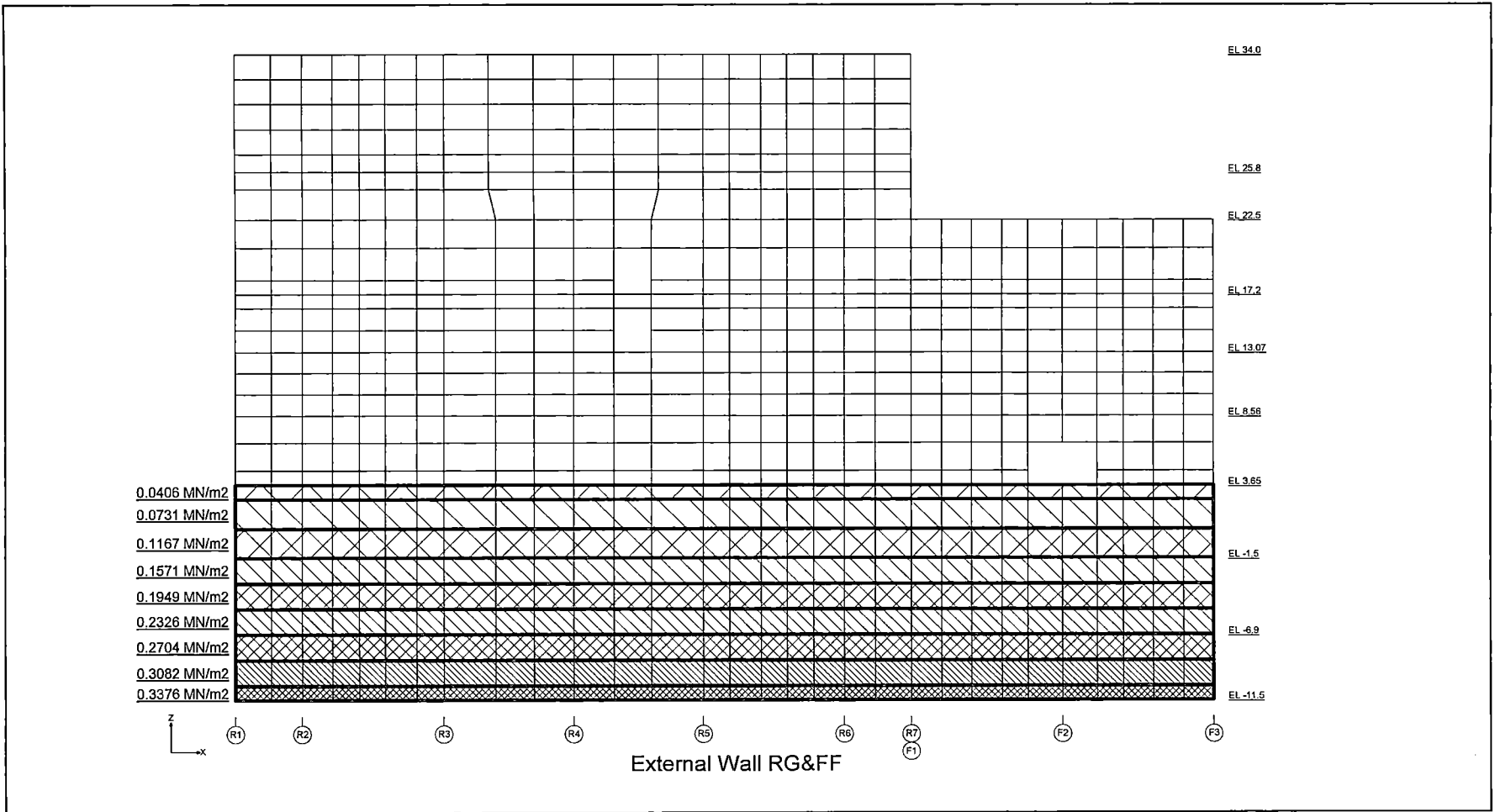


Figure 6.2.3.2-5 Lateral Soil Pressure Load at Rest (RG/FF External Wall)

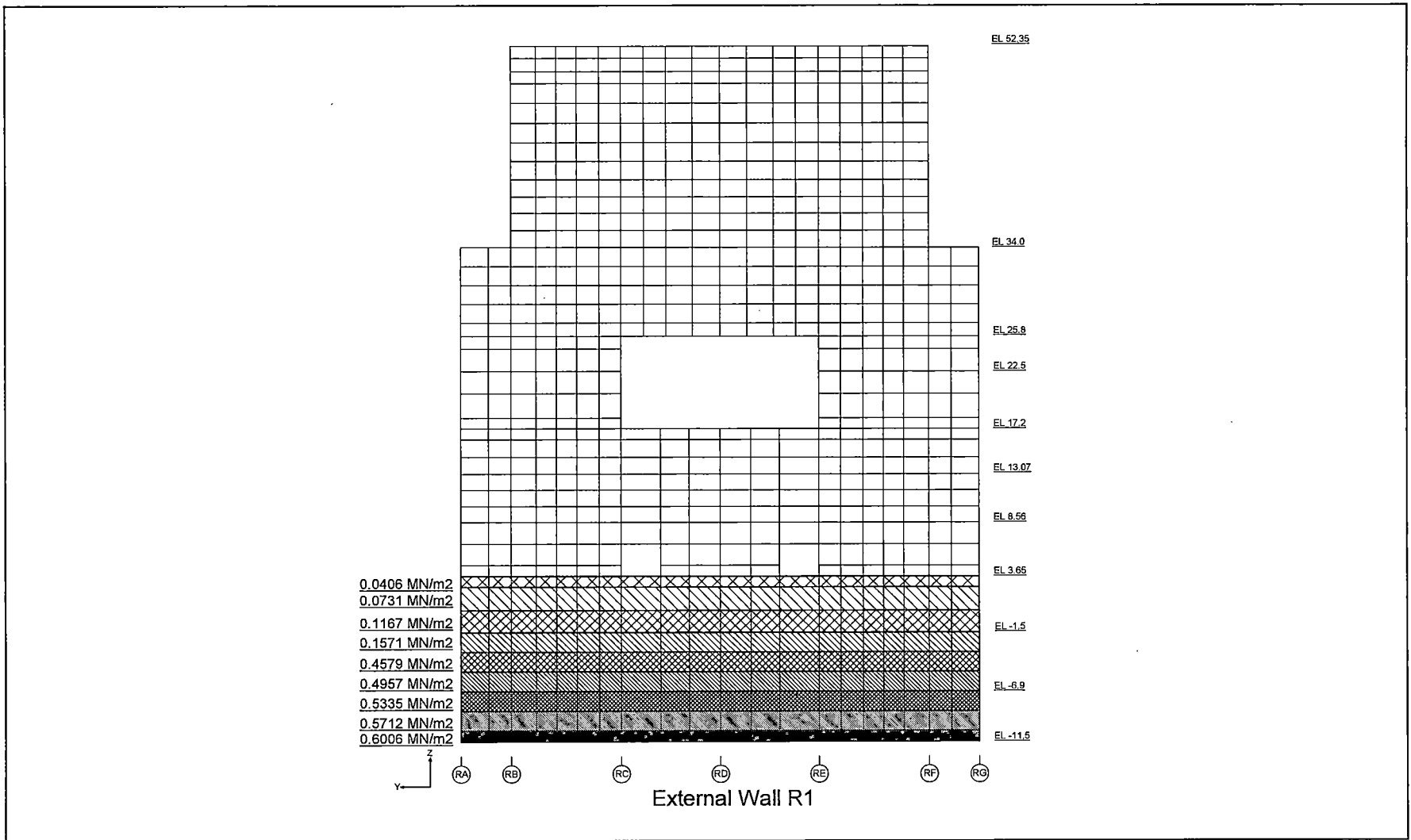


Figure 6.2.3.2-6 Lateral Soil Pressure Load at Rest (R1 External Wall)

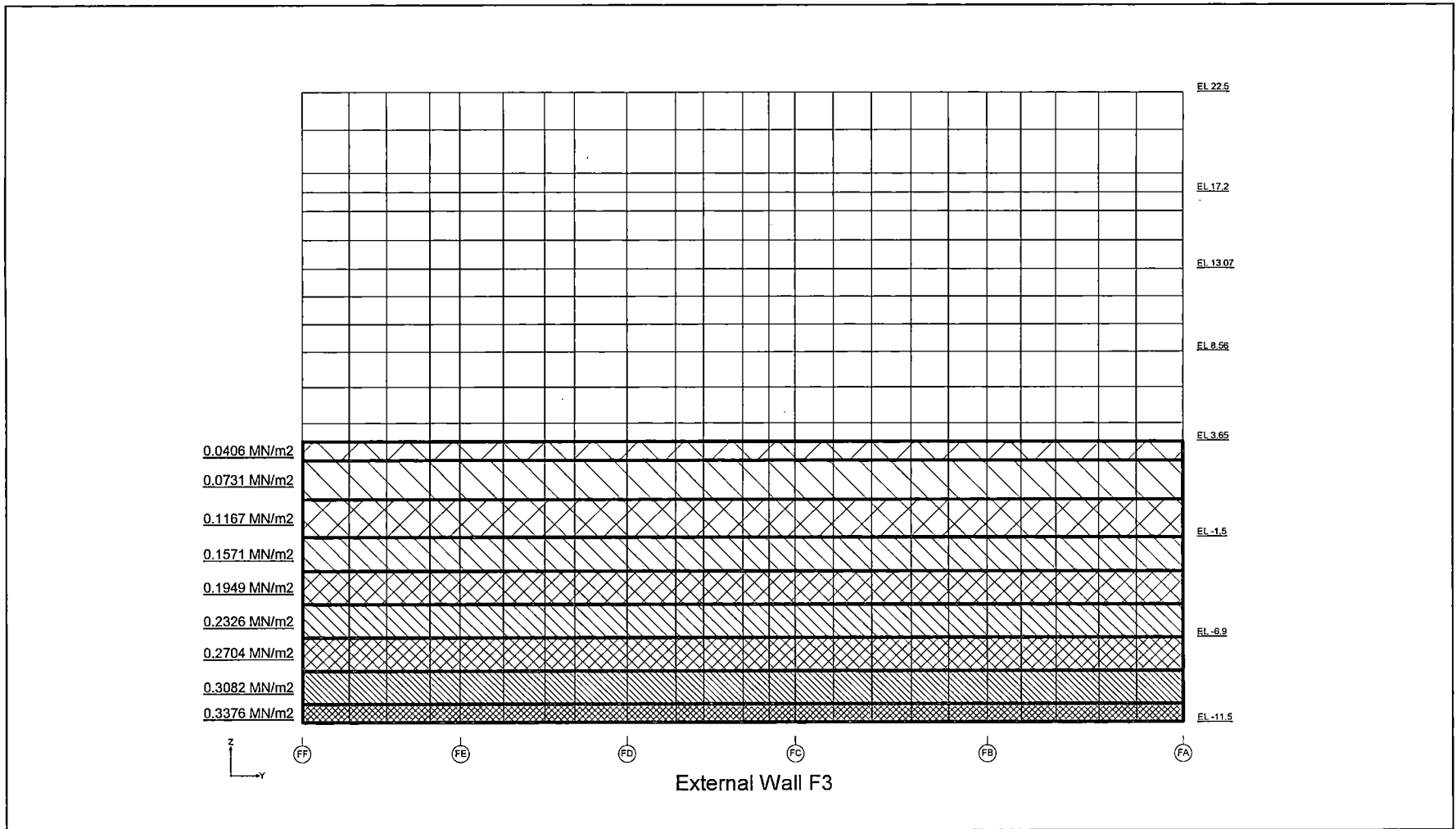


Figure 6.2.3.2-7 Lateral Soil Pressure Load at Rest (F3 External Wall)

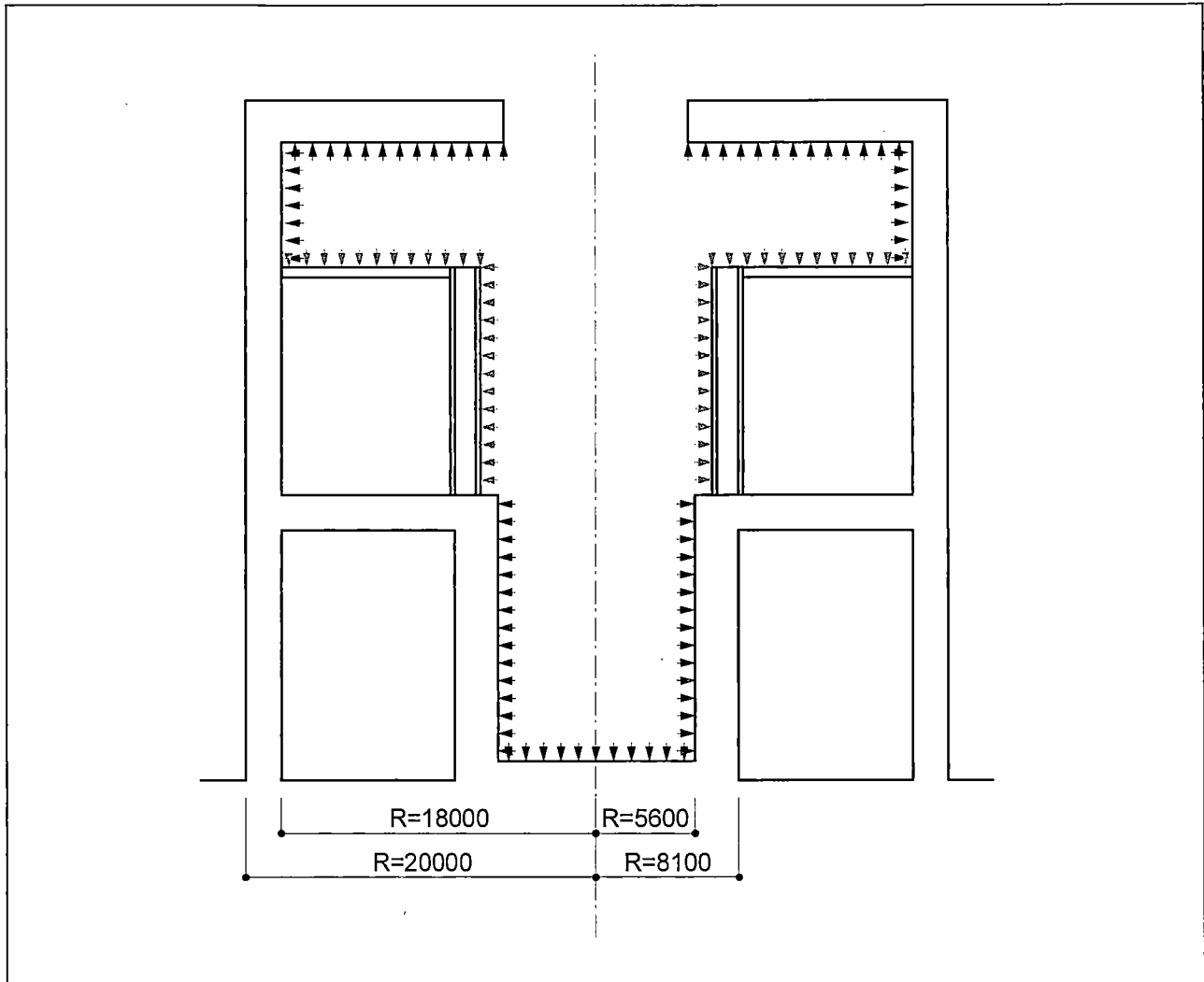


Figure 6.2.3.3-1 Containment Pressure Loads - Drywell Unit Pressure

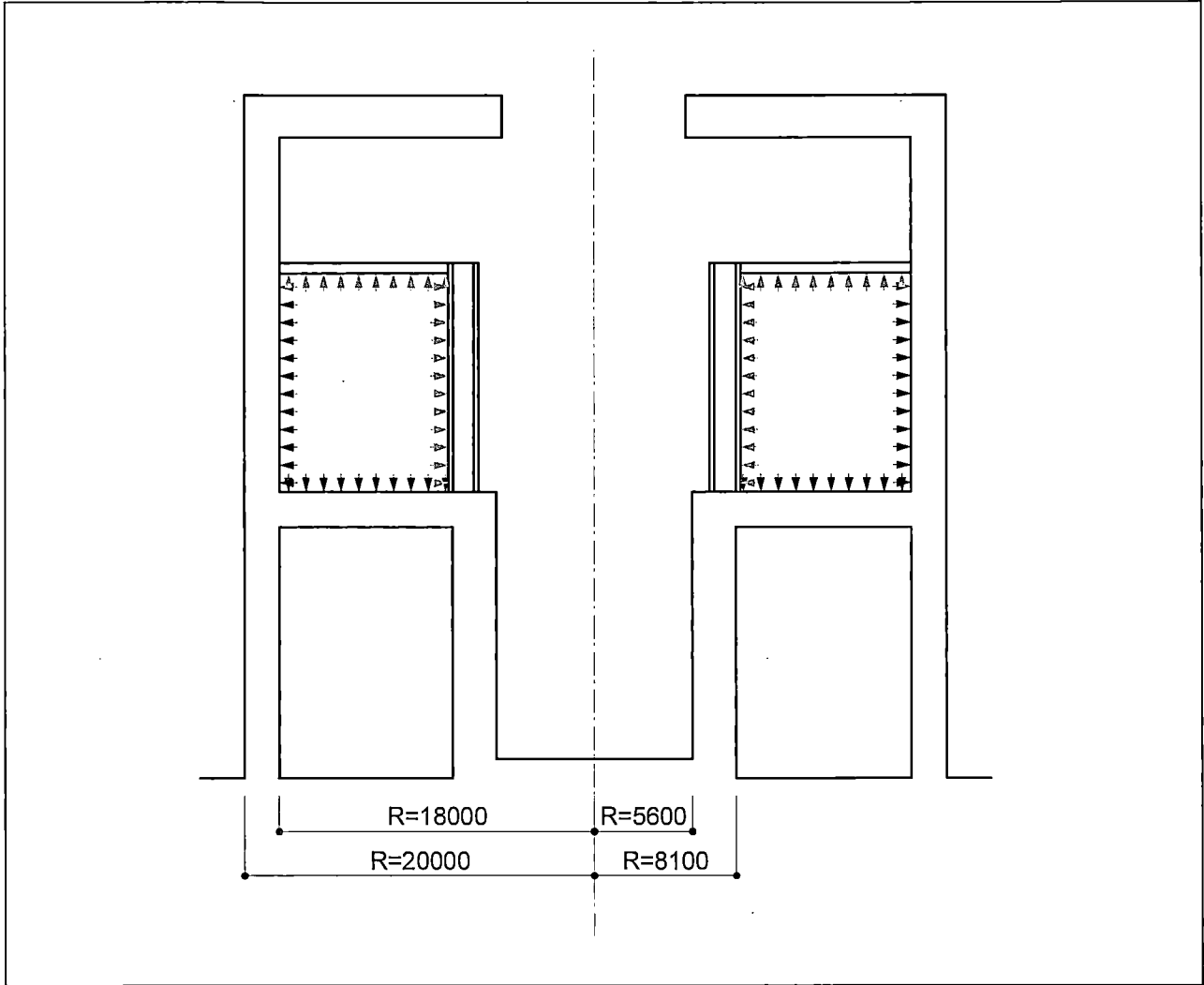


Figure 6.2.3.3-2 Containment Pressure Loads - Wetwell Unit Pressure



HITACHI

WG3-U71-ERD-S-0004 SH NO. 335
REV. 0 of 538

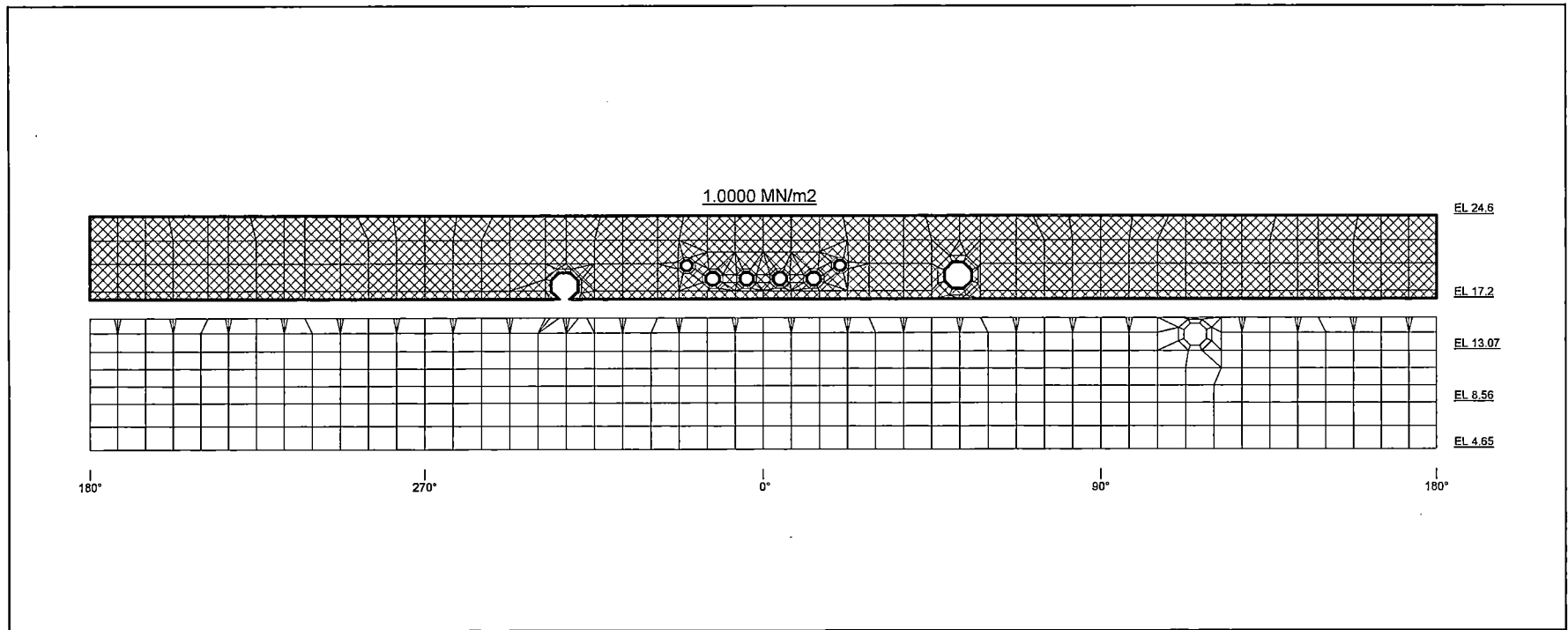


Figure 6.2.3.3-3 Containment Pressure Load (Drywell: RCCV Liner)



HITACHI

WG3-U71-ERD-S-0004 SH NO. 336
REV. 0 of 538

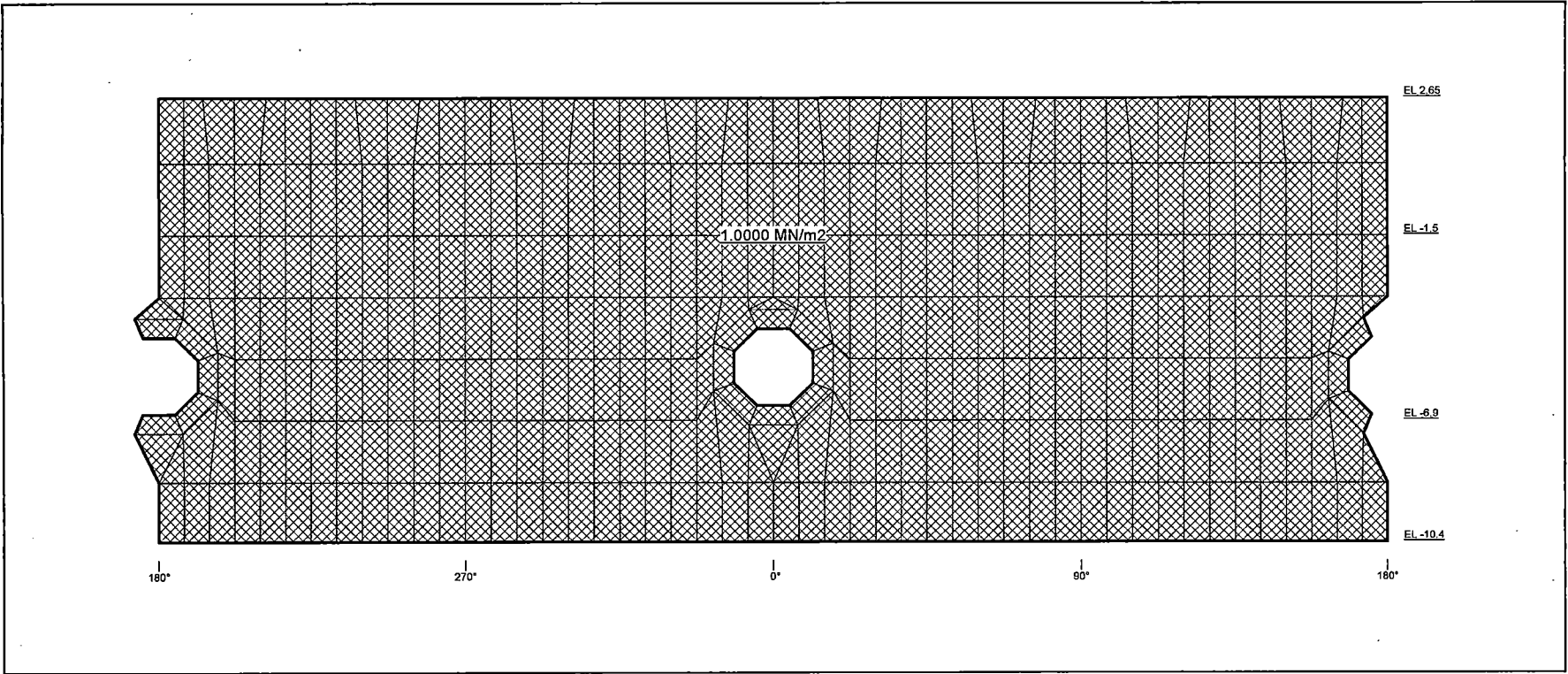


Figure 6.2.3.3-4 Containment Pressure Load (Drywell: RPV Pedestal Liner)



HITACHI

WG3-U71-ERD-S-0004 SH NO. 337
REV. 0 of 538

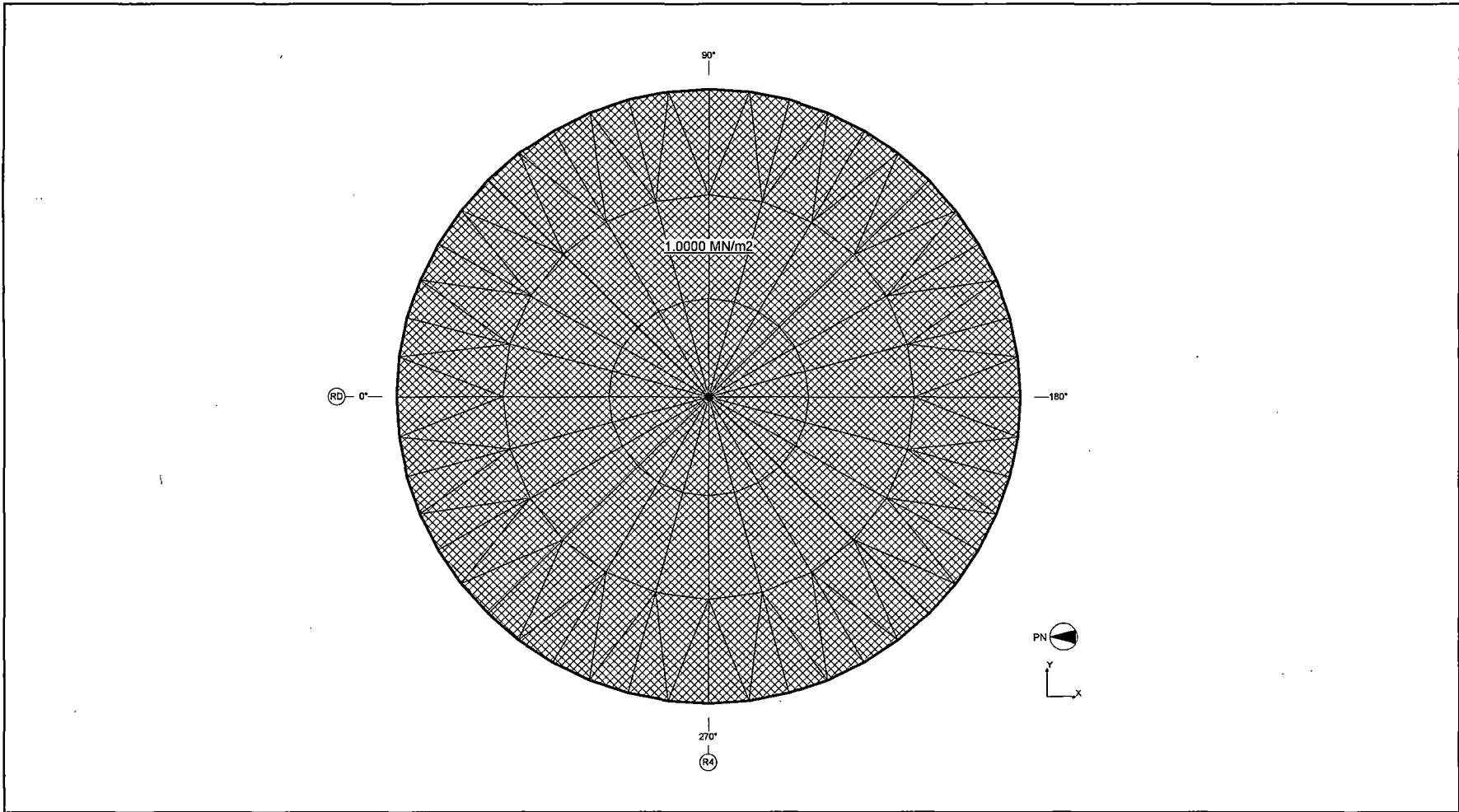


Figure 6.2.3.3-5 Containment Pressure Load (Drywell: Basemat Liner)



HITACHI

WG3-U71-ERD-S-0004 SH NO. 338
REV. 0 of 538

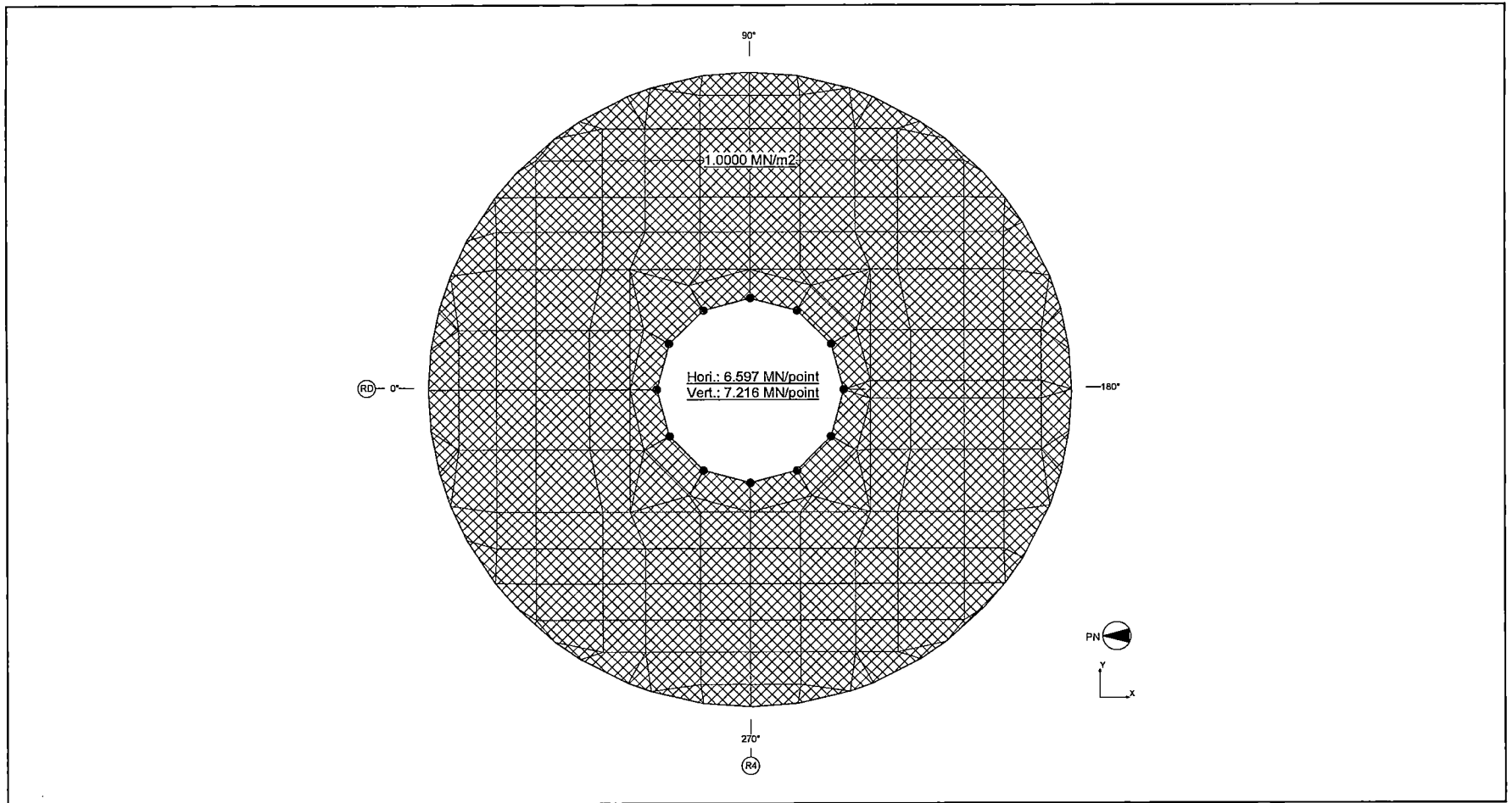


Figure 6.2.3.3-6 Containment Pressure Load (Drywell: Topslab Liner)

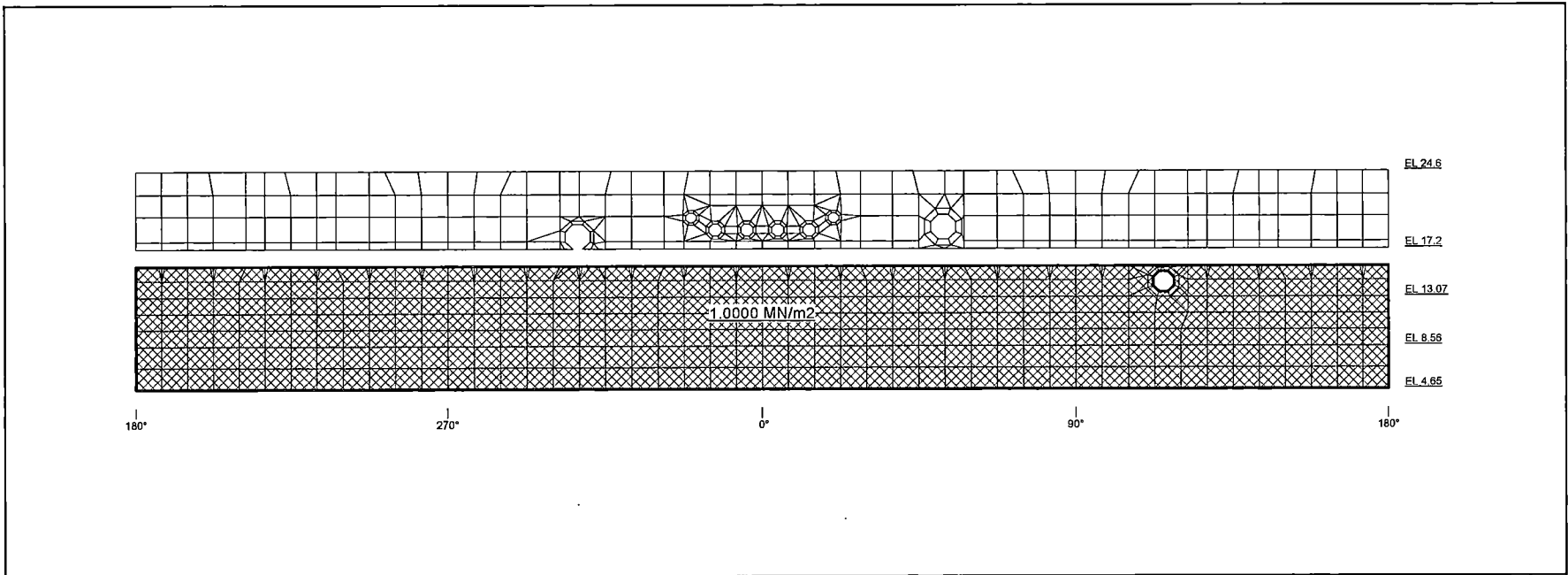


Figure 6.2.3.3-7 Containment Pressure Load (Wetwell: RCCV Liner)



HITACHI

WG3-U71-ERD-S-0004 SH NO. 340
REV. 0 of 538

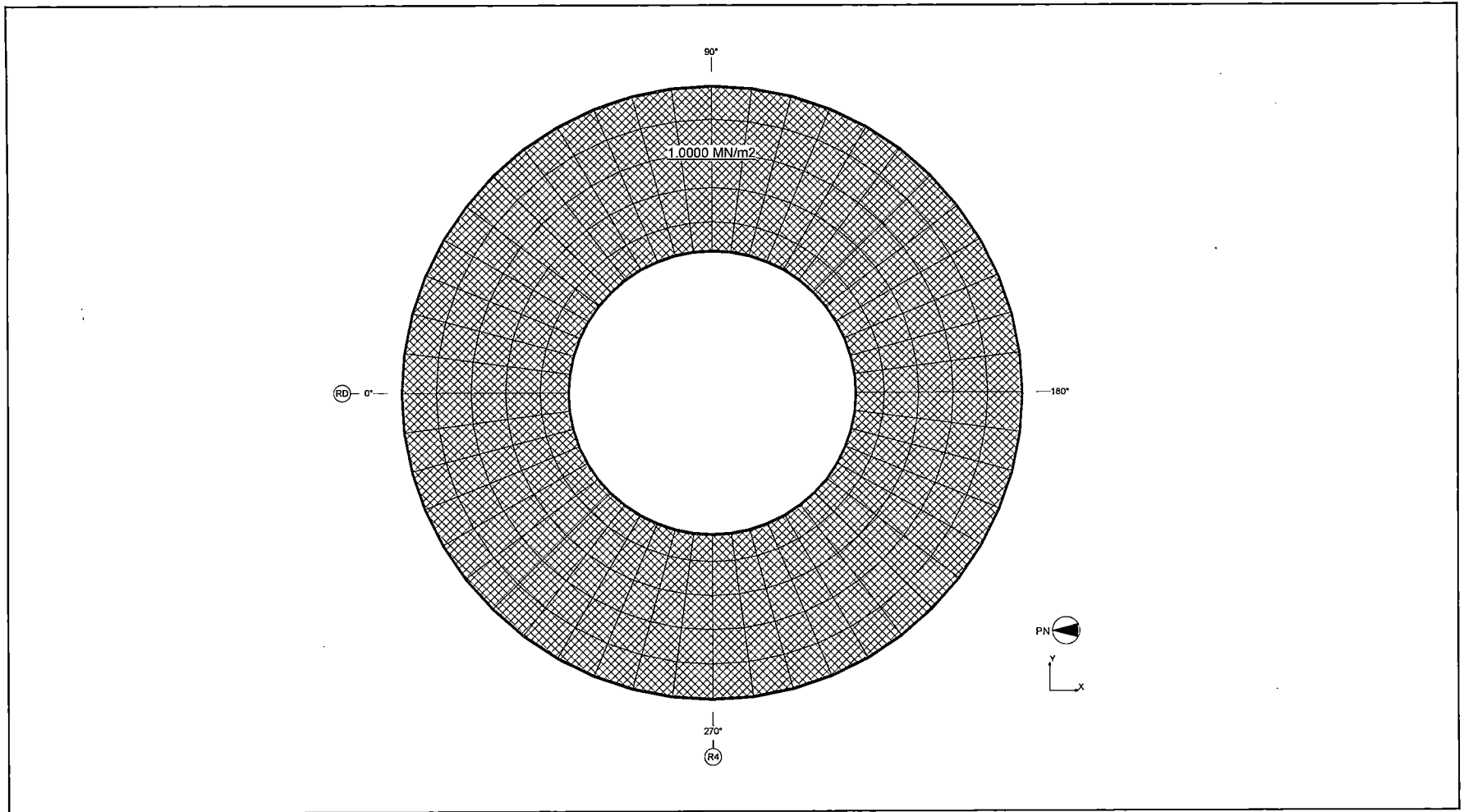


Figure 6.2.3.3-8 Containment Pressure Load (Wetwell: Suppression Pool Slab Liner)



HITACHI

WG3-U71-ERD-S-0004

SH NO. 341

REV. 0

of 538

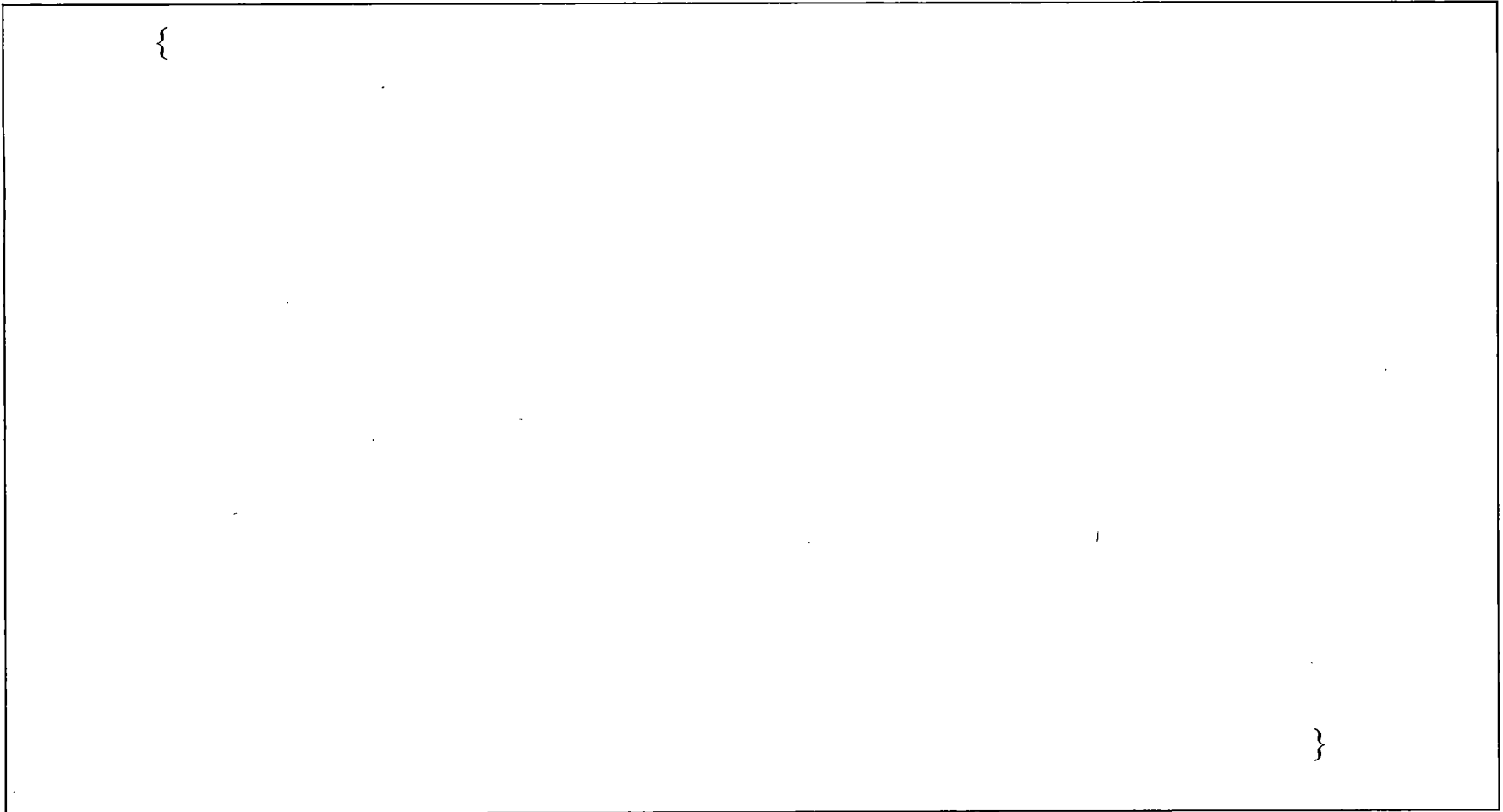


Figure 6.2.3.3-9 Containment Pressure Load (IC/PCCS Pool: Slab at EL 27,000)

{{{Contains Security-Related Information – Withheld Under 10 CFR 2.390.}}}



HITACHI

WG3-U71-ERD-S-0004

SH NO. 342

REV. 0

of 538

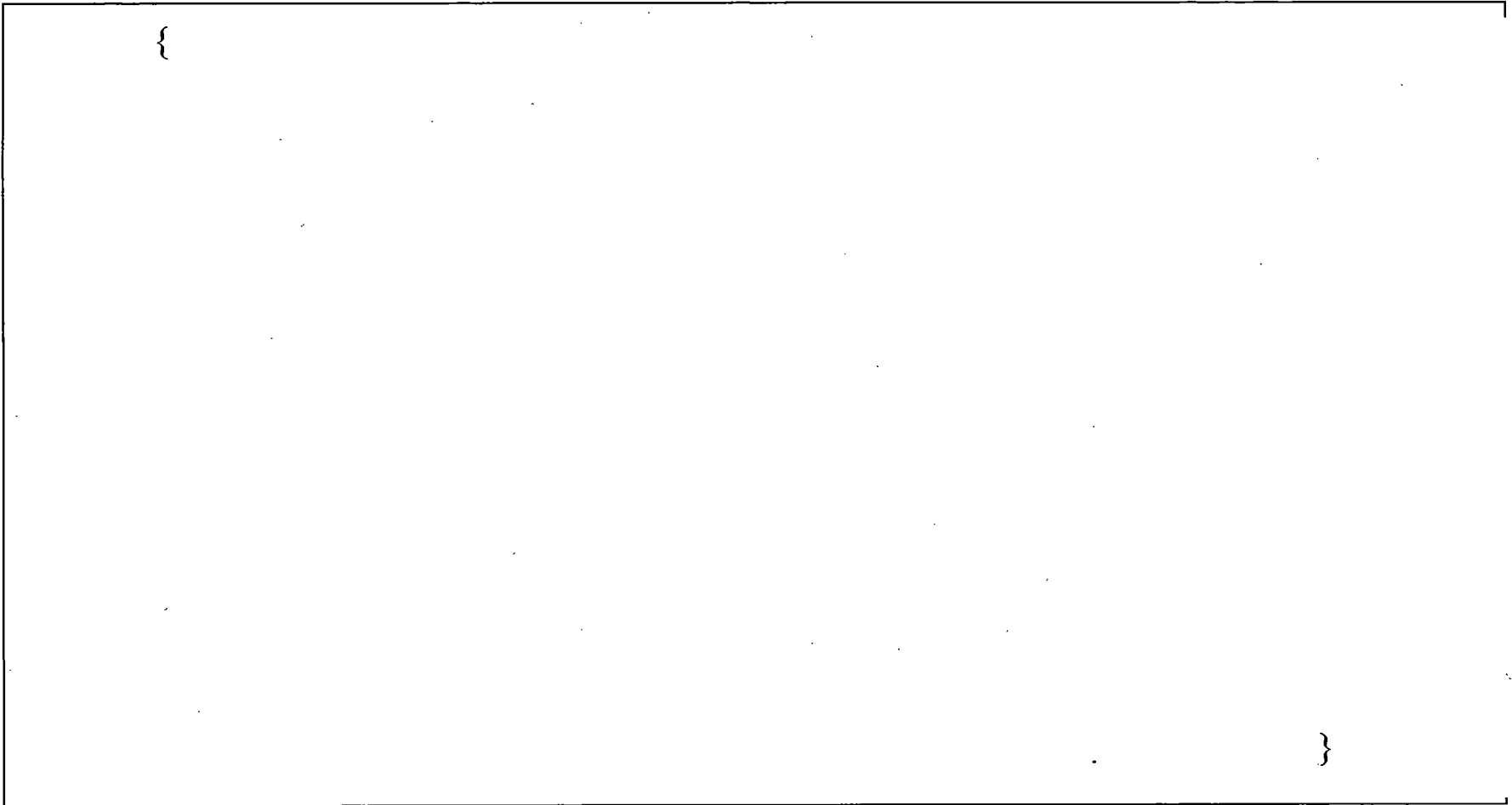


Figure 6.2.3.3-10 Containment Pressure Load (IC/PCCS Pool: Slab at EL 34,000)

{{{Contains Security-Related Information – Withheld Under 10 CFR 2.390.}}}

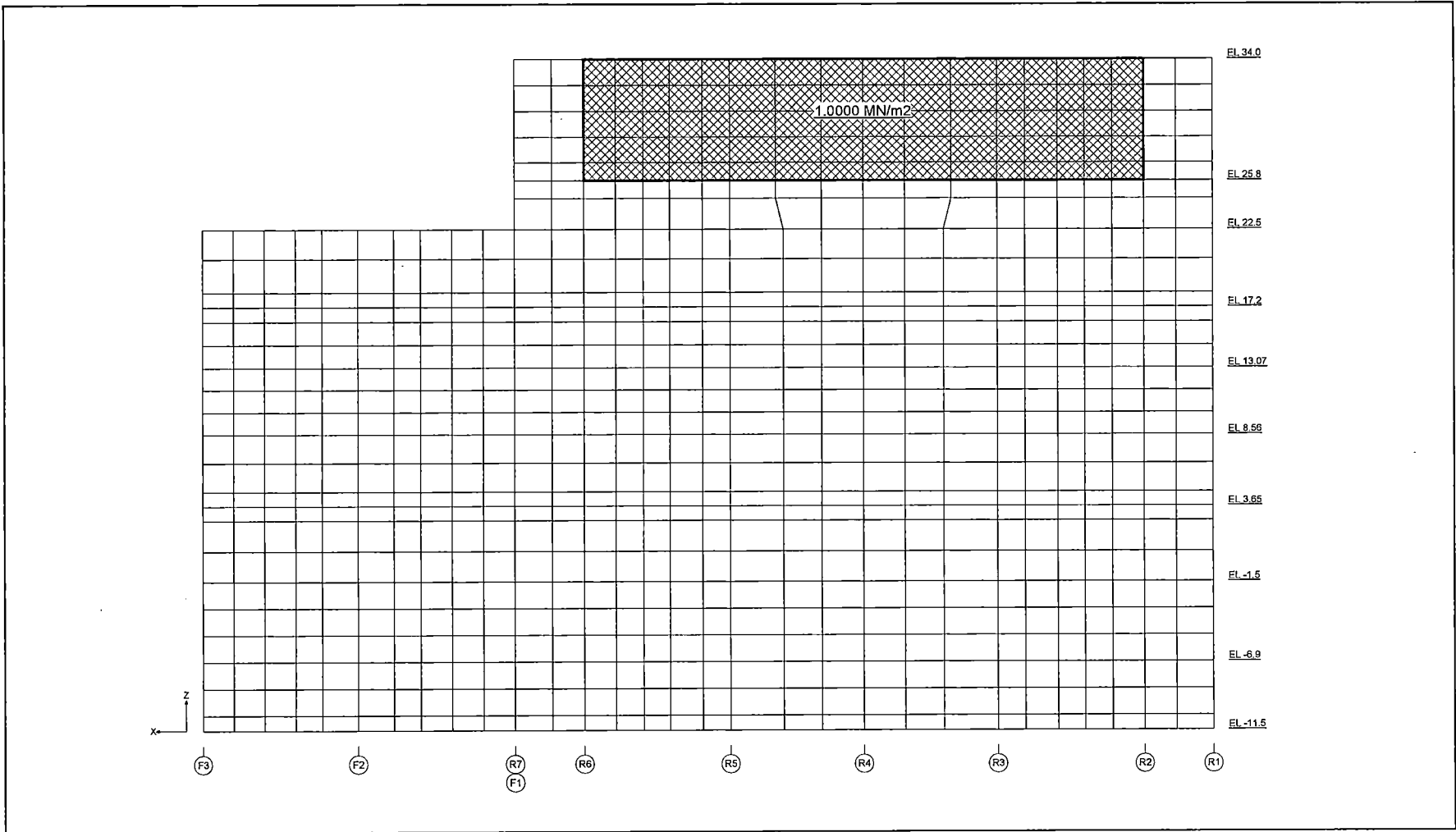


Figure 6.2.3.3-11 Containment Pressure Load (IC/PCCS Pool: External Wall RA)



HITACHI

WG3-U71-ERD-S-0004

SH NO. 344

REV. 0

of 538

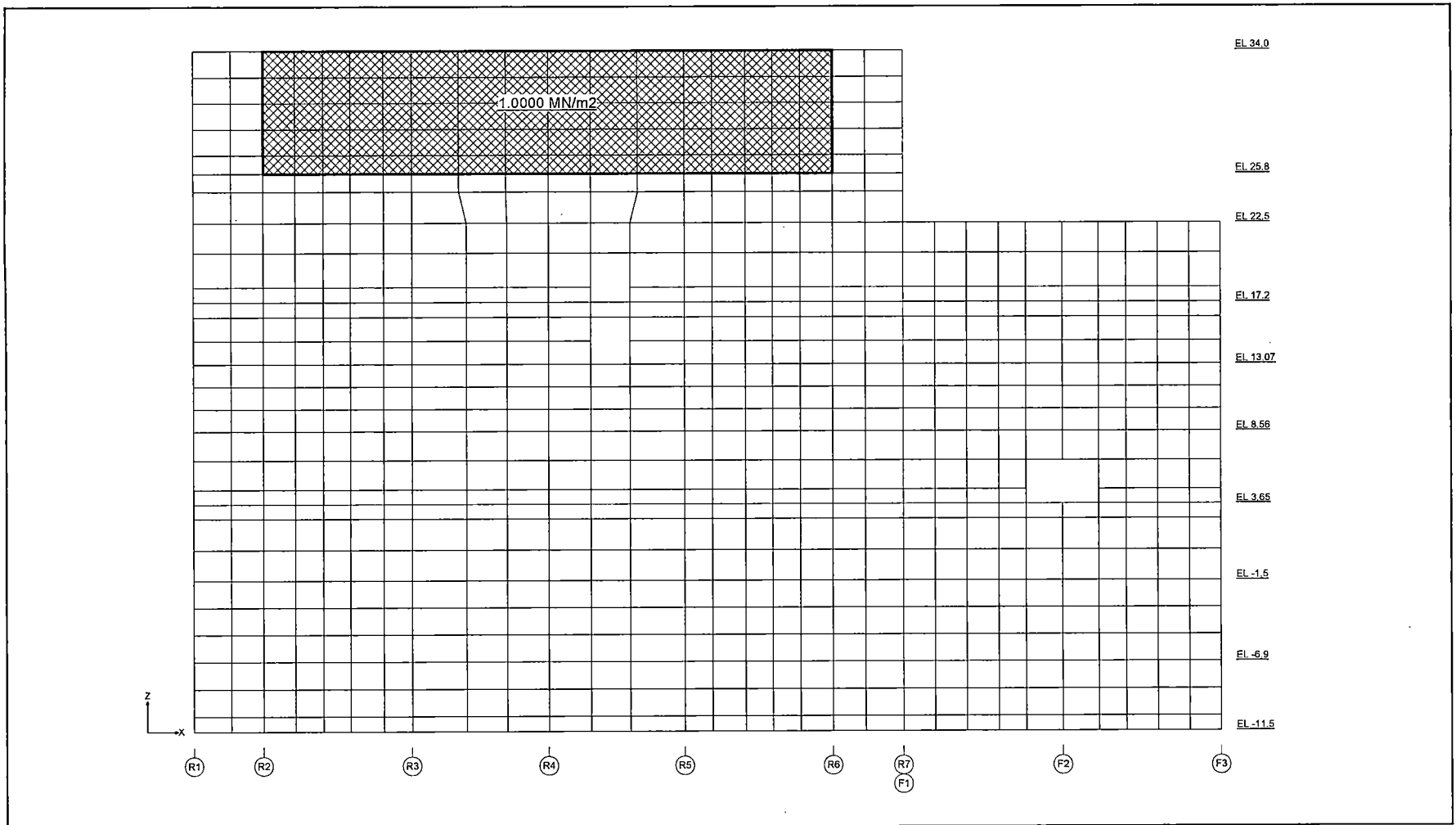


Figure 6.2.3.3-12 Containment Pressure Load (IC/PCCS Pool: External Wall RG)

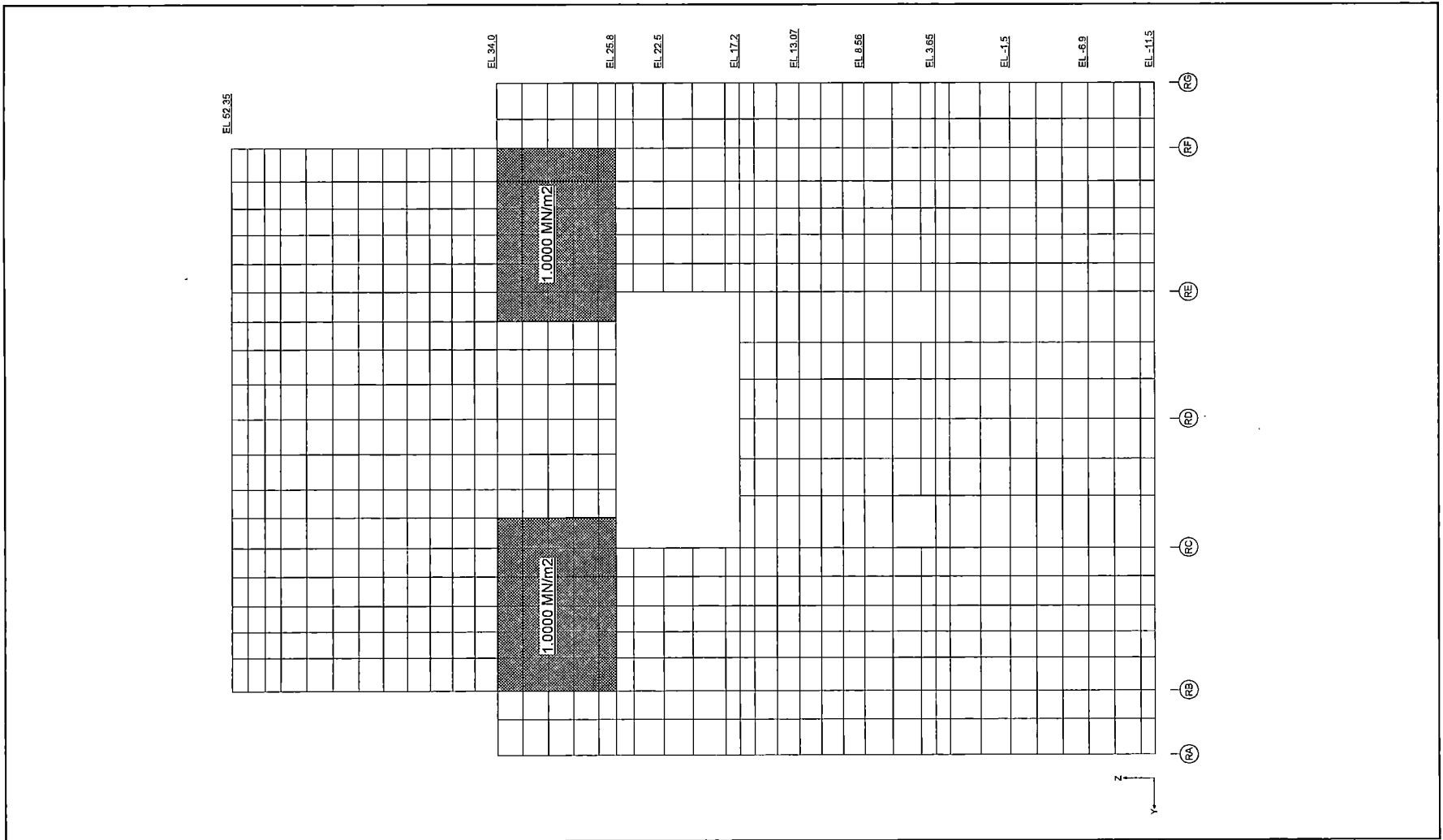


Figure 6.2.3.3-13 Containment Pressure Load (IC/PCCS Pool: External Wall R1)



HITACHI

WG3-U71-ERD-S-0004 SH NO. 346
REV. 0 of 538

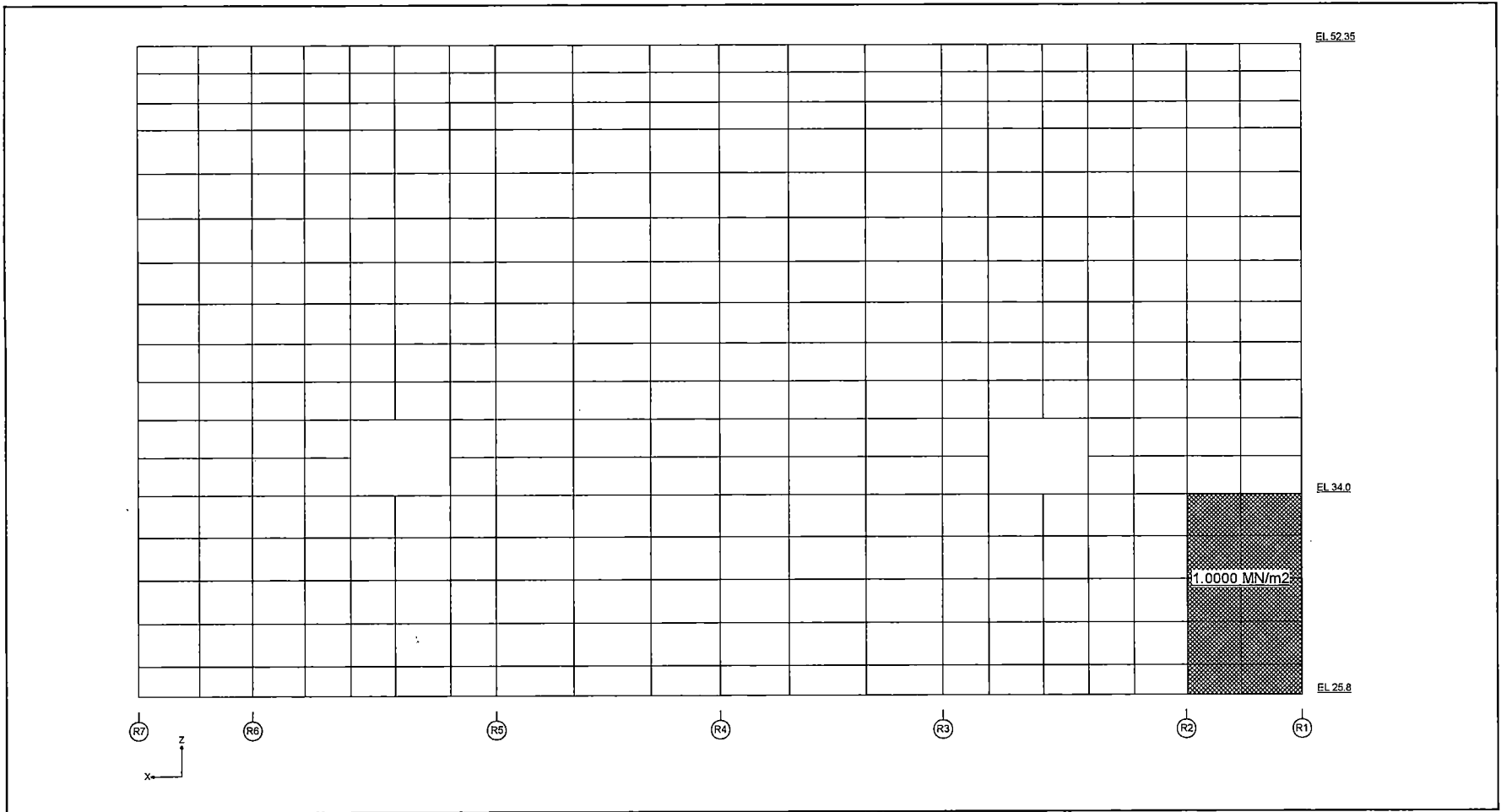


Figure 6.2.3.3-14 Containment Pressure Load (IC/PCCS Pool: Wall RB)



HITACHI

WG3-U71-ERD-S-0004 SH NO. 347
REV. 0 of 538

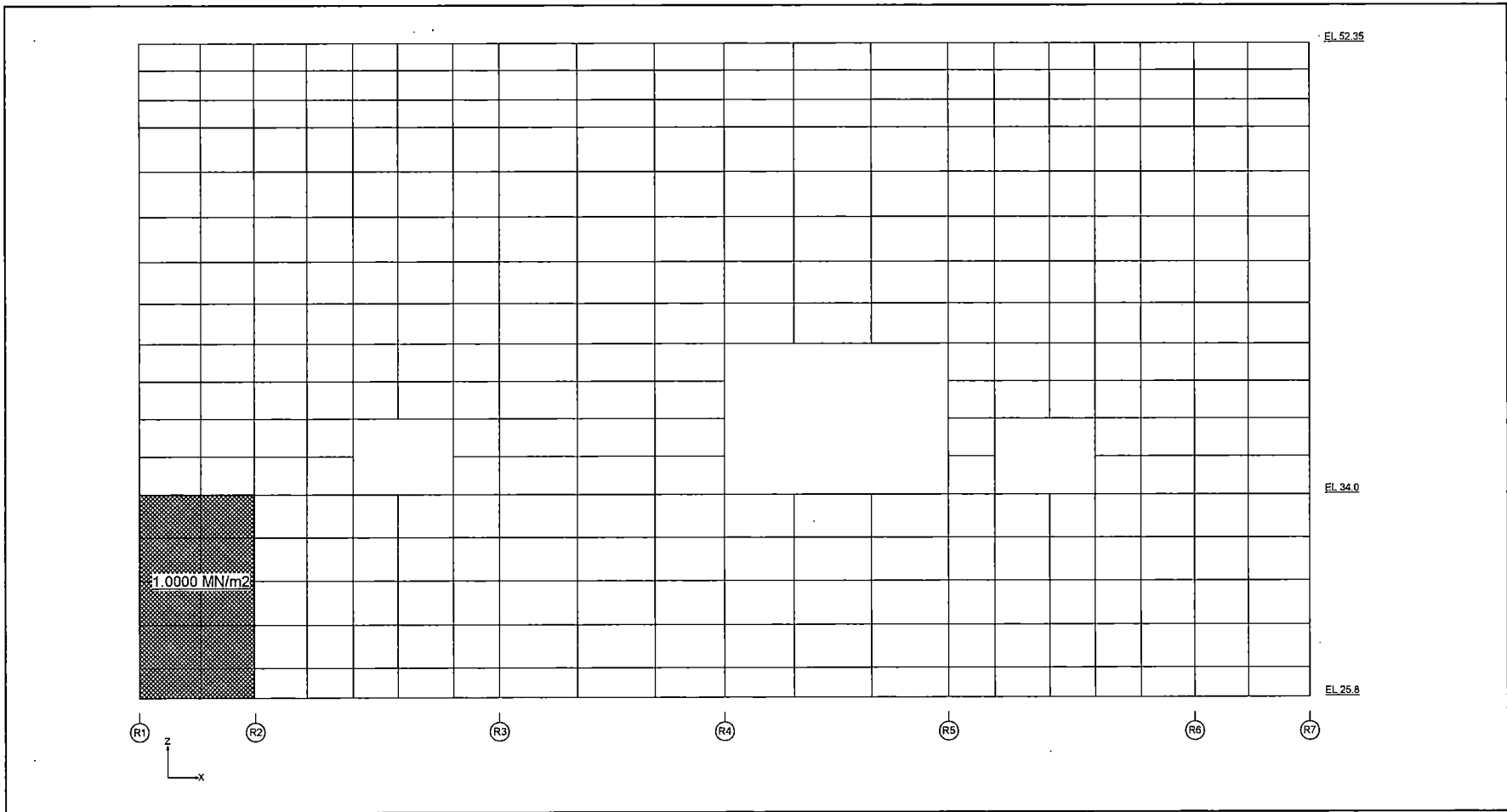


Figure 6.2.3.3-15 Containment Pressure Load (IC/PCCS Pool: Wall RF)

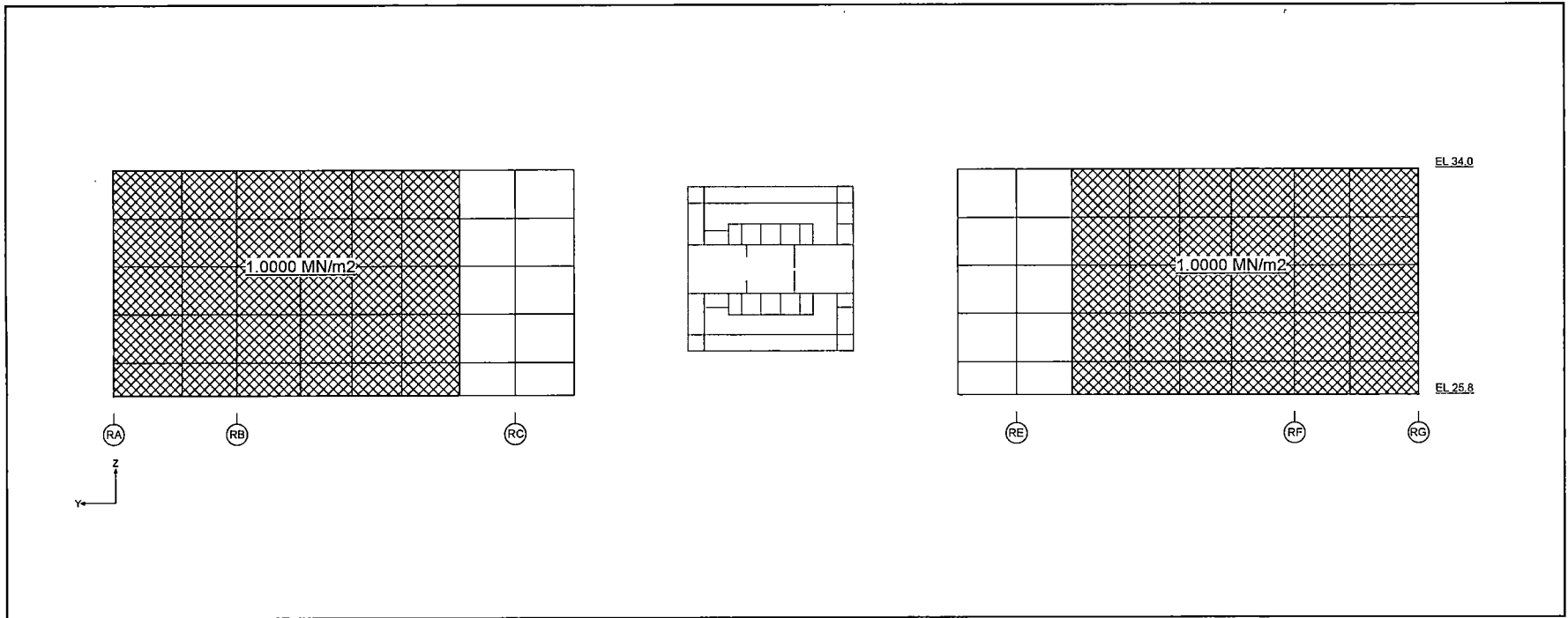


Figure 6.2.3.3-16 Containment Pressure Load (IC/PCCS Pool: Wall R2)

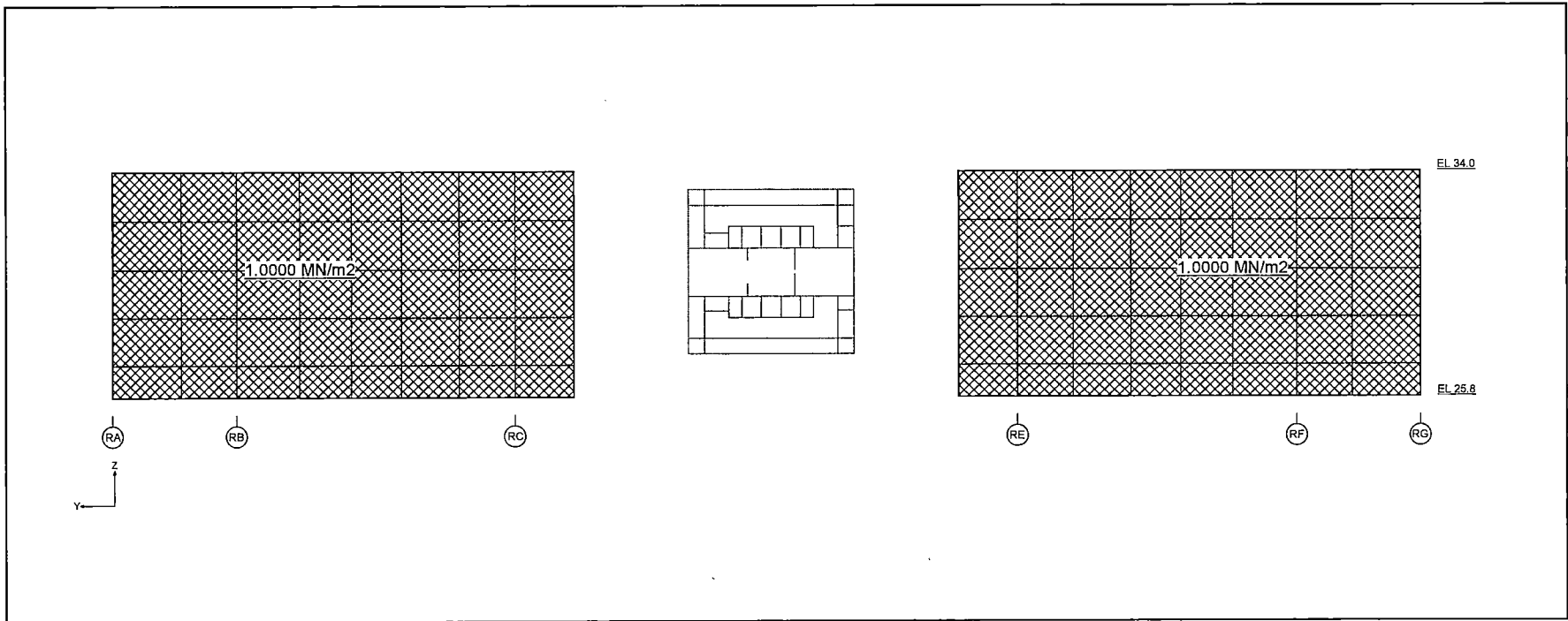


Figure 6.2.3.3-17 Containment Pressure Load (IC/PCCS Pool: Wall R6)



HITACHI

WG3-U71-ERD-S-0004

SH NO. 350

REV. 0

of 538

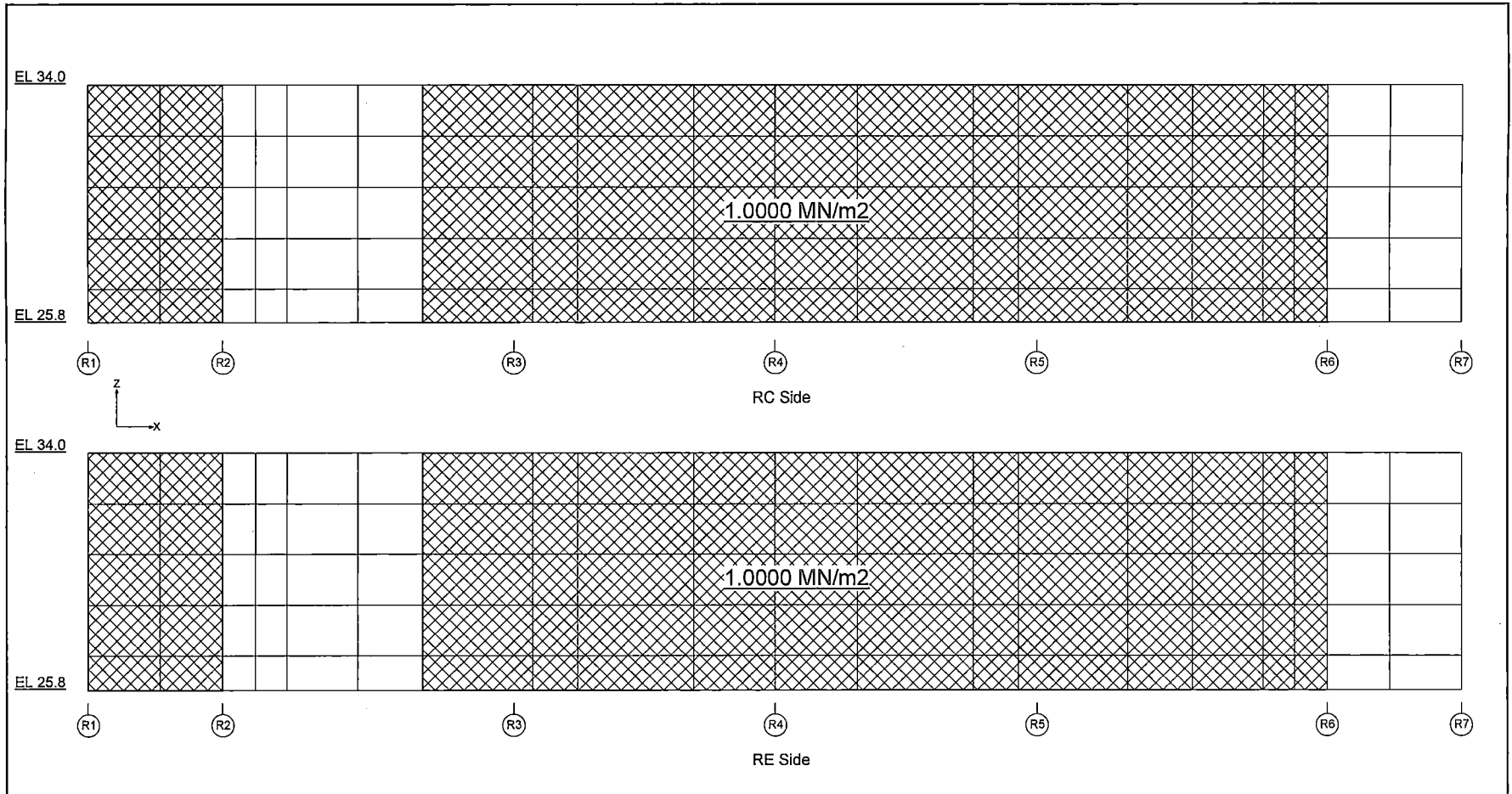


Figure 6.2.3.3-18 Containment Pressure Load (IC/PCCS Pool: Pool Girder)

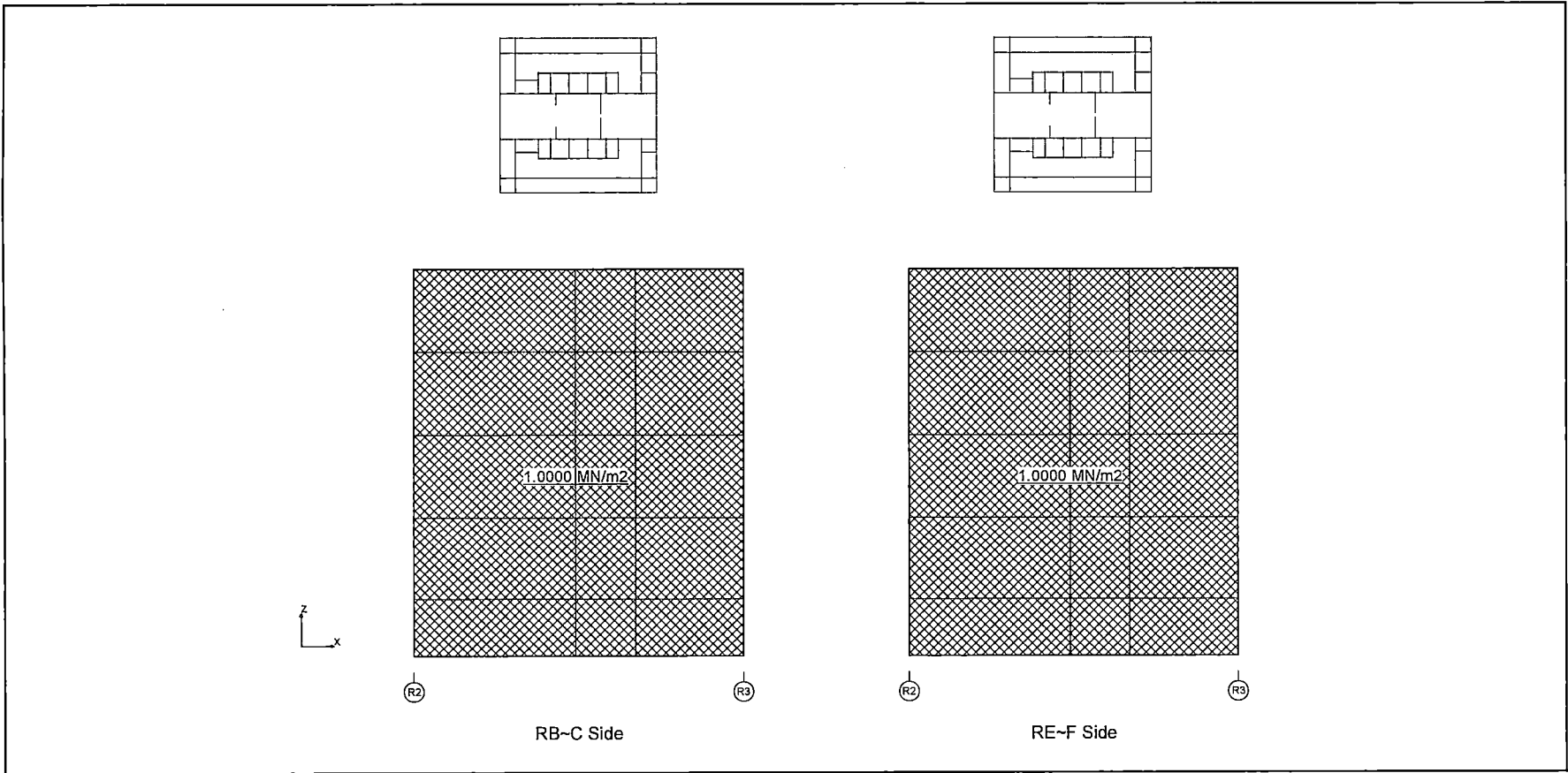


Figure 6.2.3.3-19 Containment Pressure Load (IC/PCCS Pool: Wall-1)

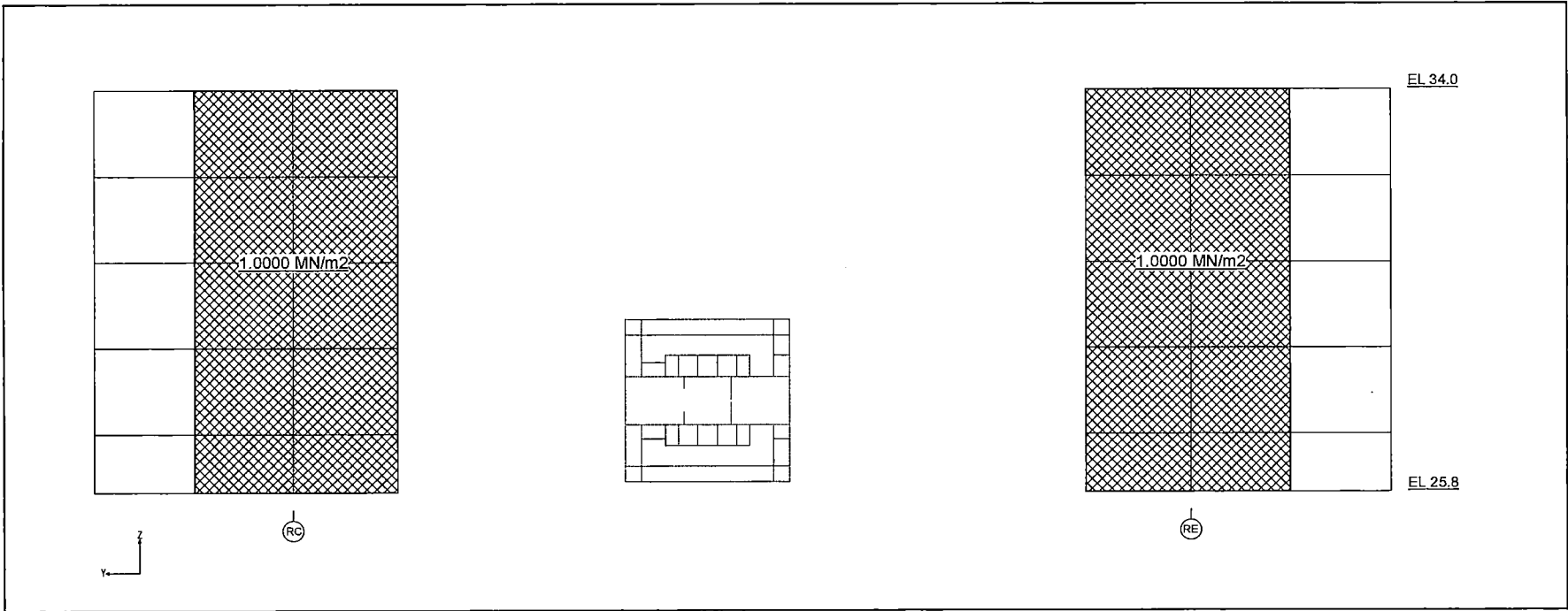


Figure 6.2.3.3-20 Containment Pressure Load (IC/PCCS Pool: Wall-2)



HITACHI

WG3-U71-ERD-S-0004

SH NO. 353

REV. 0

of 538

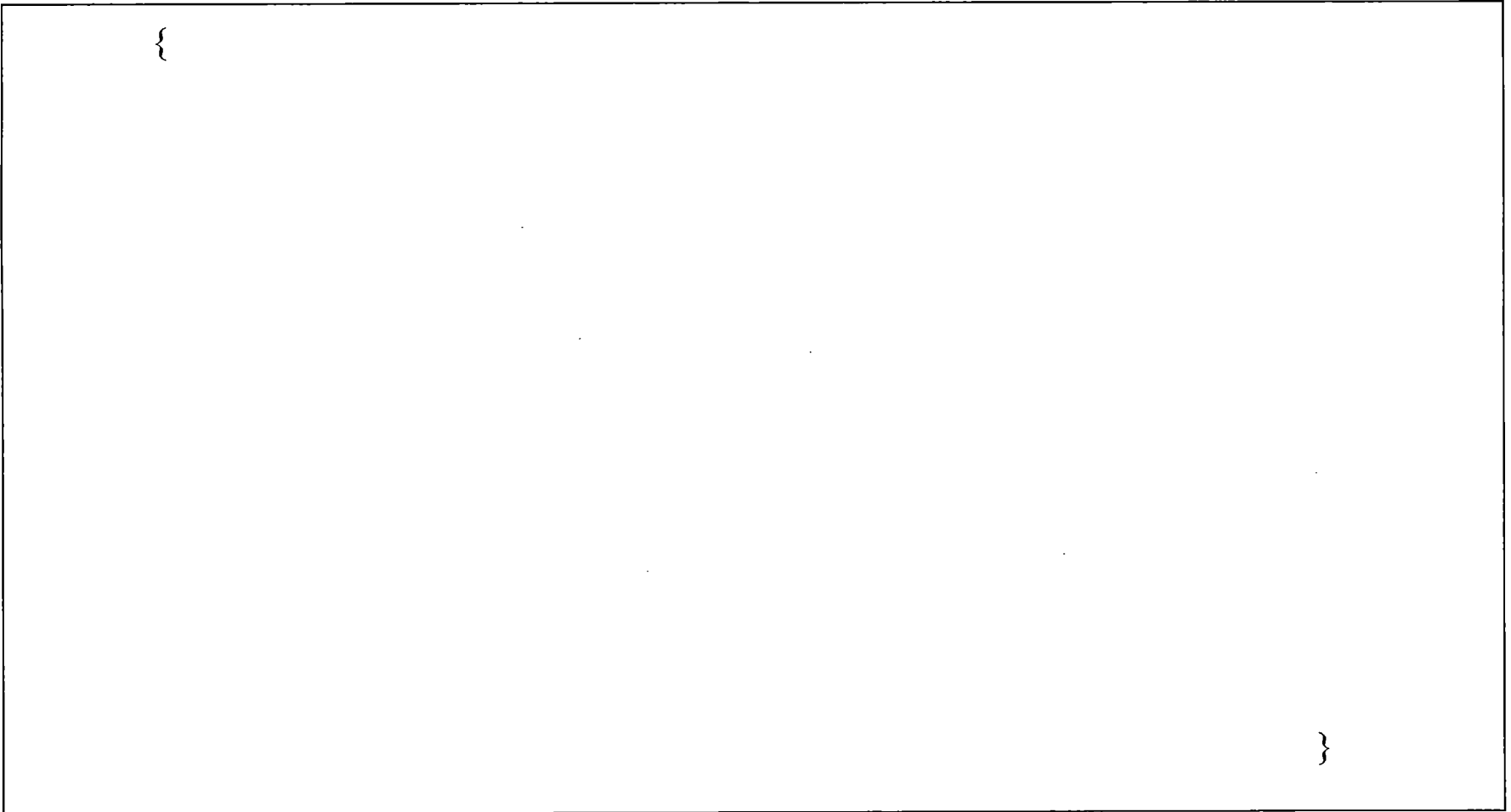


Figure 6.2.3.3-21 HELB Pressure Load (MS Tunnel: Slab at EL 17,500)

{{{Contains Security-Related Information – Withheld Under 10 CFR 2.390.}}}



HITACHI

WG3-U71-ERD-S-0004

SH NO. 354

REV. 0

of 538

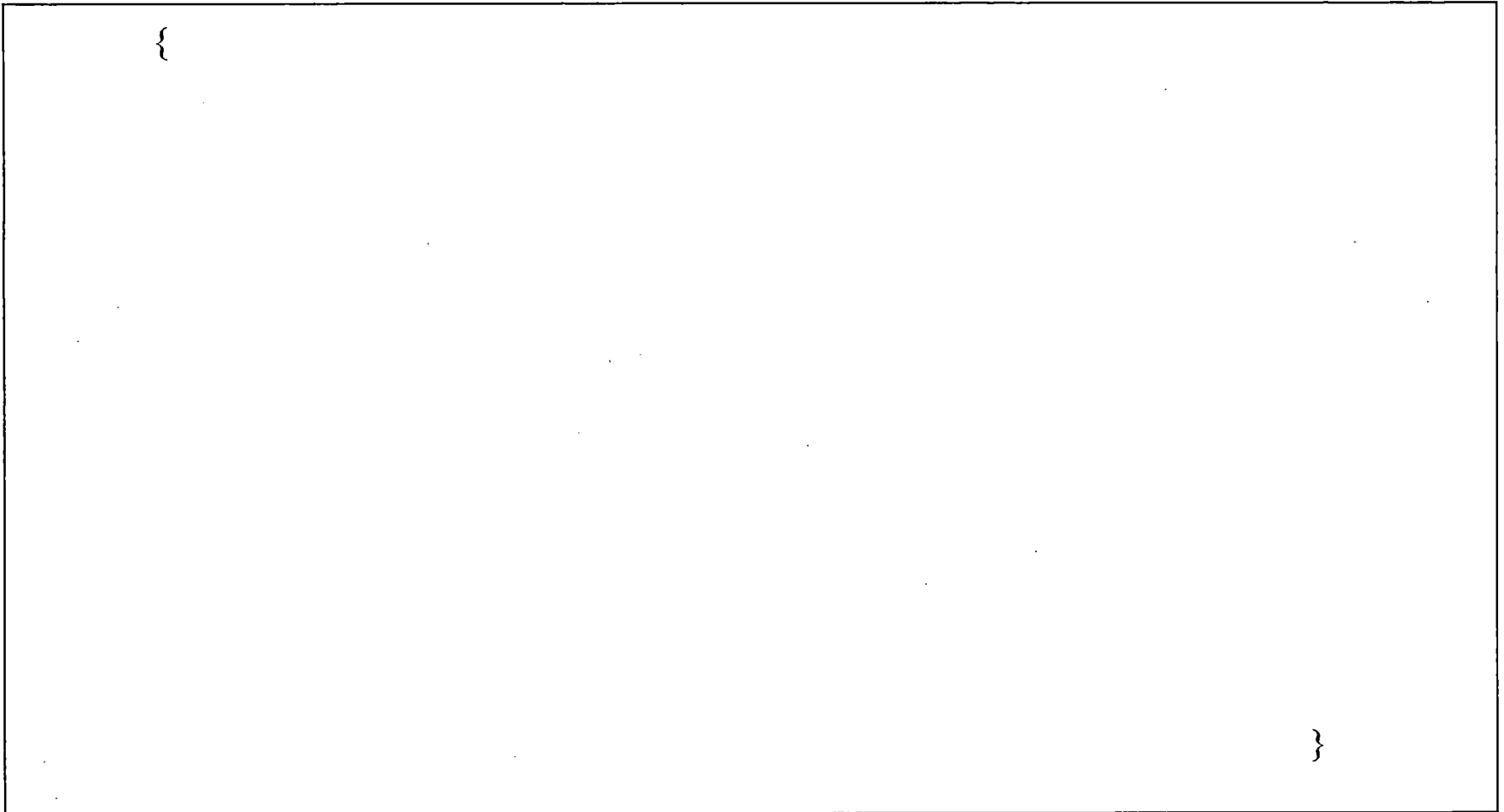


Figure 6.2.3.3-22 HELB Pressure Load (MS Tunnel: Slab at EL 27,000)

{{{Contains Security-Related Information – Withheld Under 10 CFR 2.390.}}}



HITACHI

WG3-U71-ERD-S-0004

SH NO. 355

REV. 0

of 538

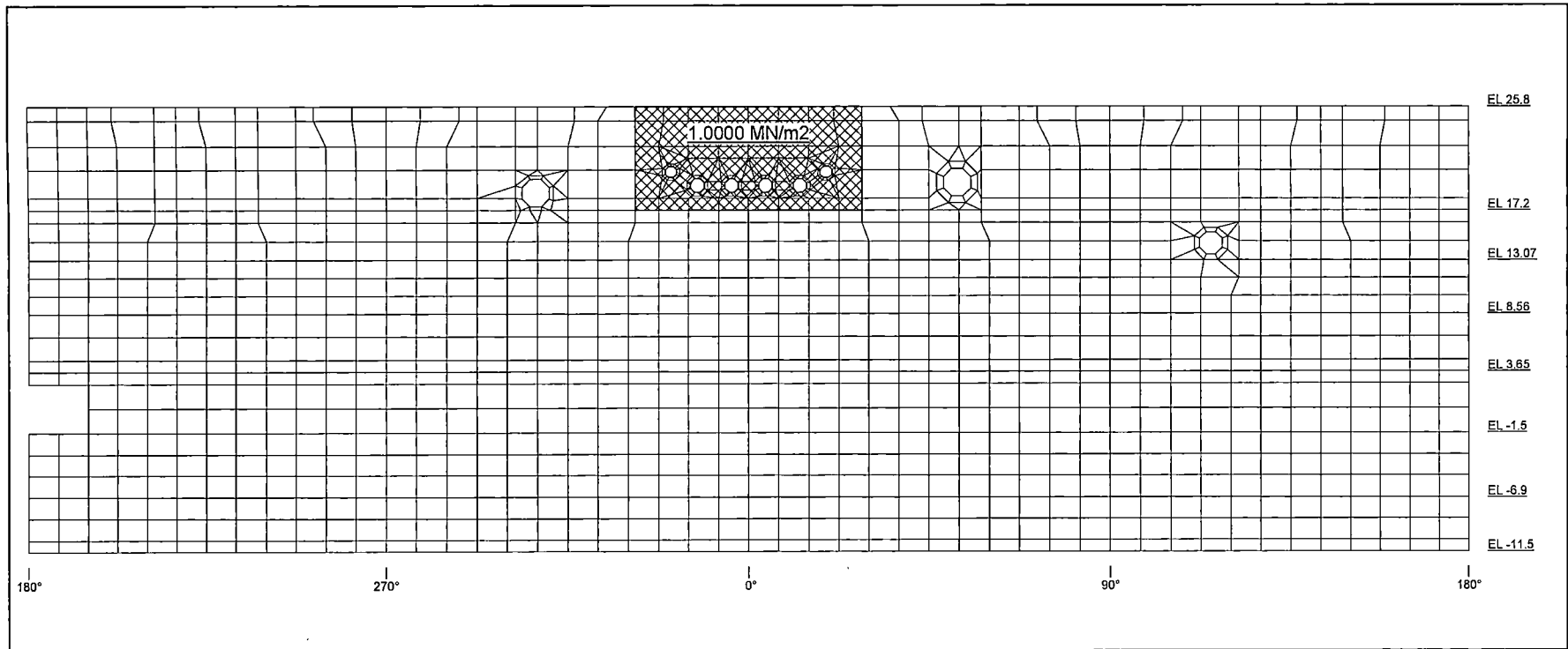


Figure 6.2.3.3-23 HELB Pressure Load (MS Tunnel: RCCV Wall)

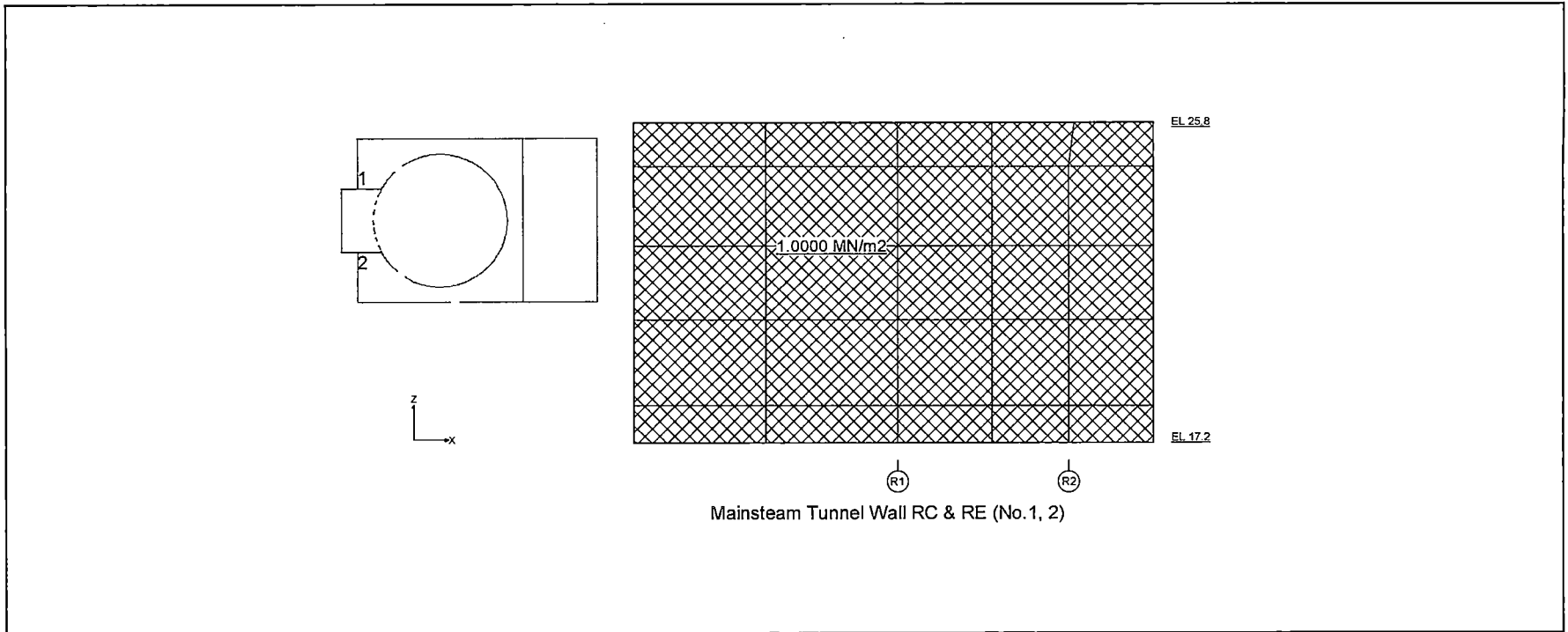


Figure 6.2.3.3-24 HELB Pressure Load (MS Tunnel: Walls)

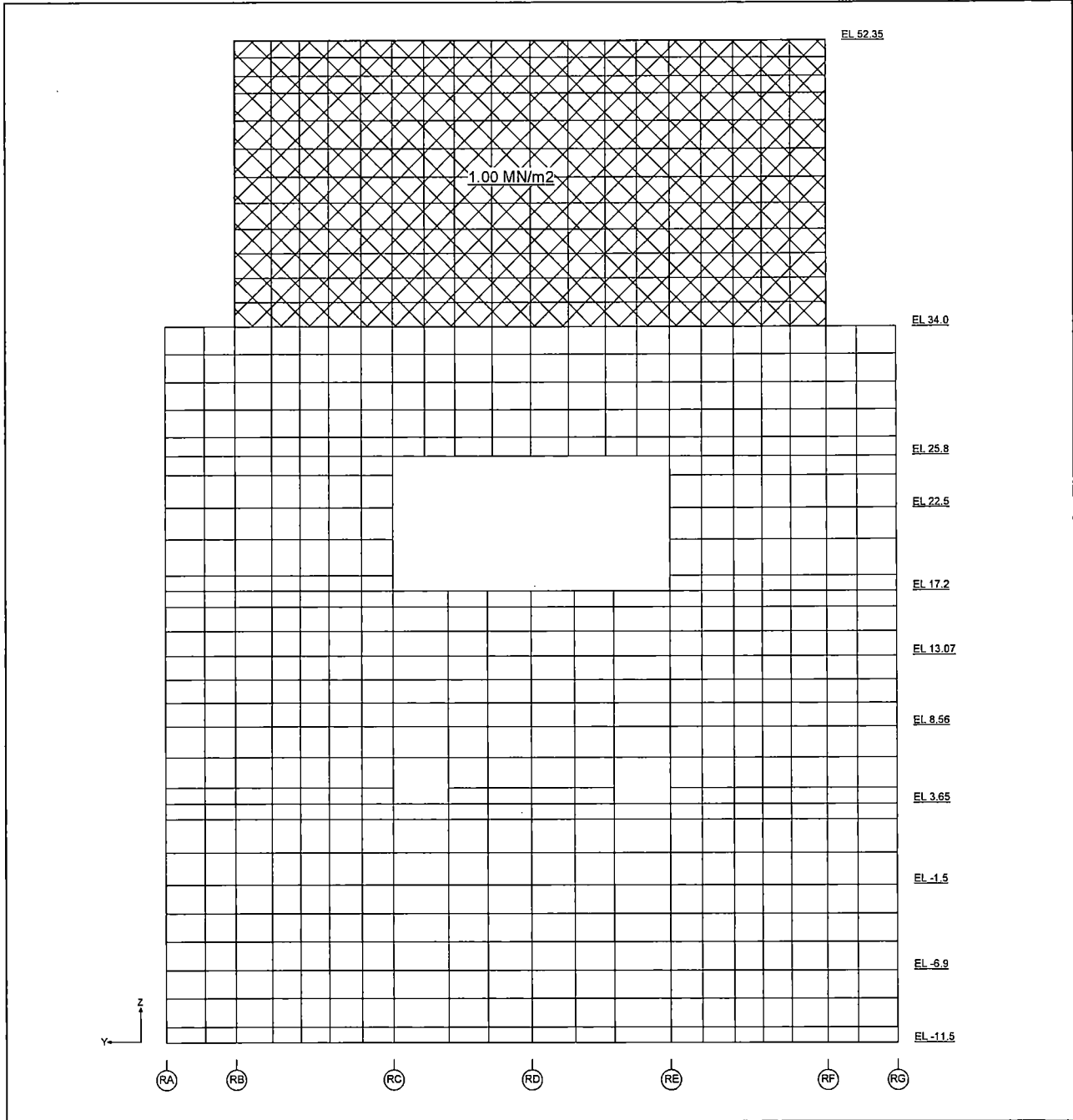


Figure 6.2.3.3-25 HELB Pressure Load (for RB General Rooms: R1 Wall)

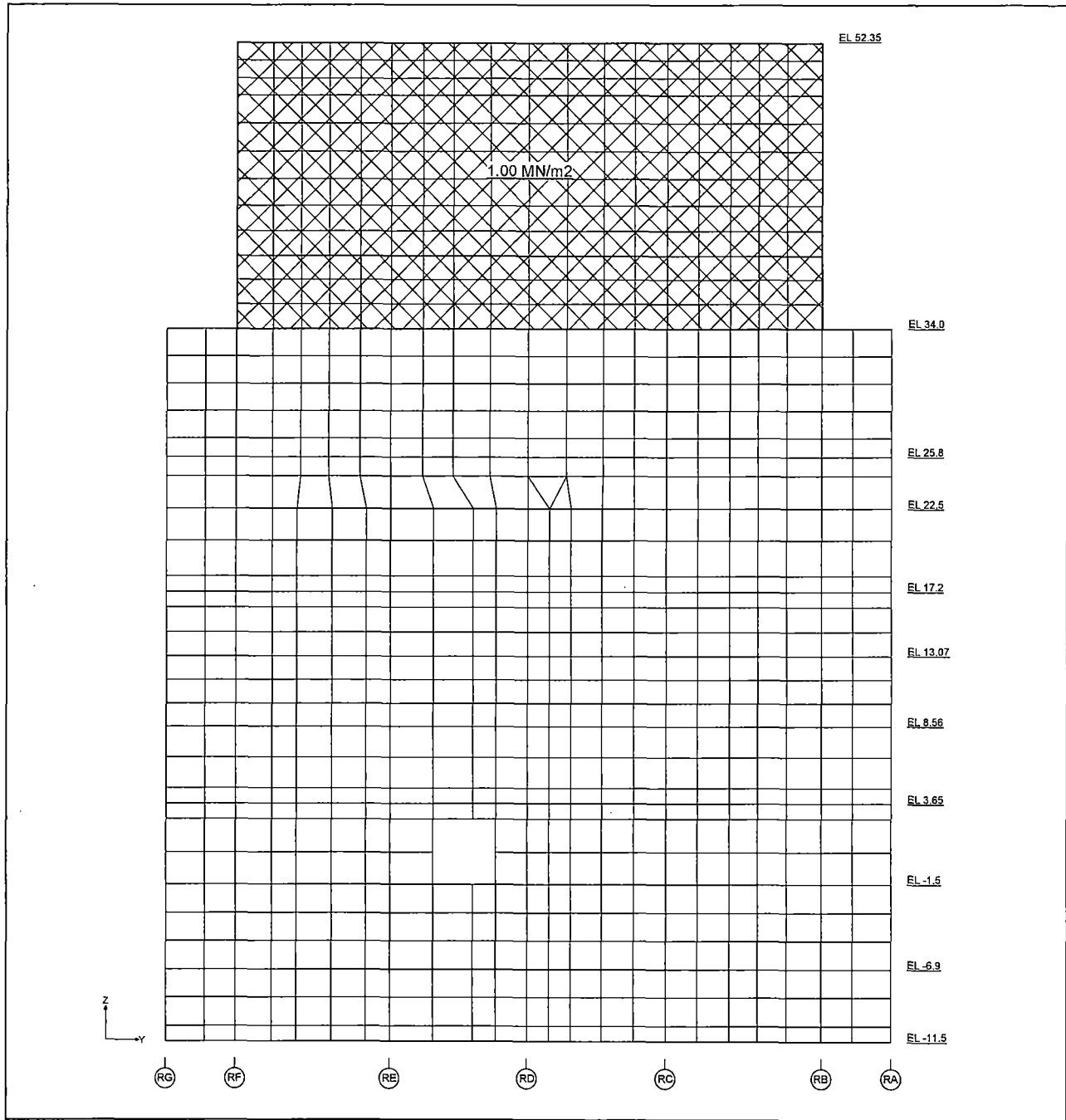


Figure 6.2.3.3-26 HELB Pressure Load (for RB General Rooms: R7 Wall)

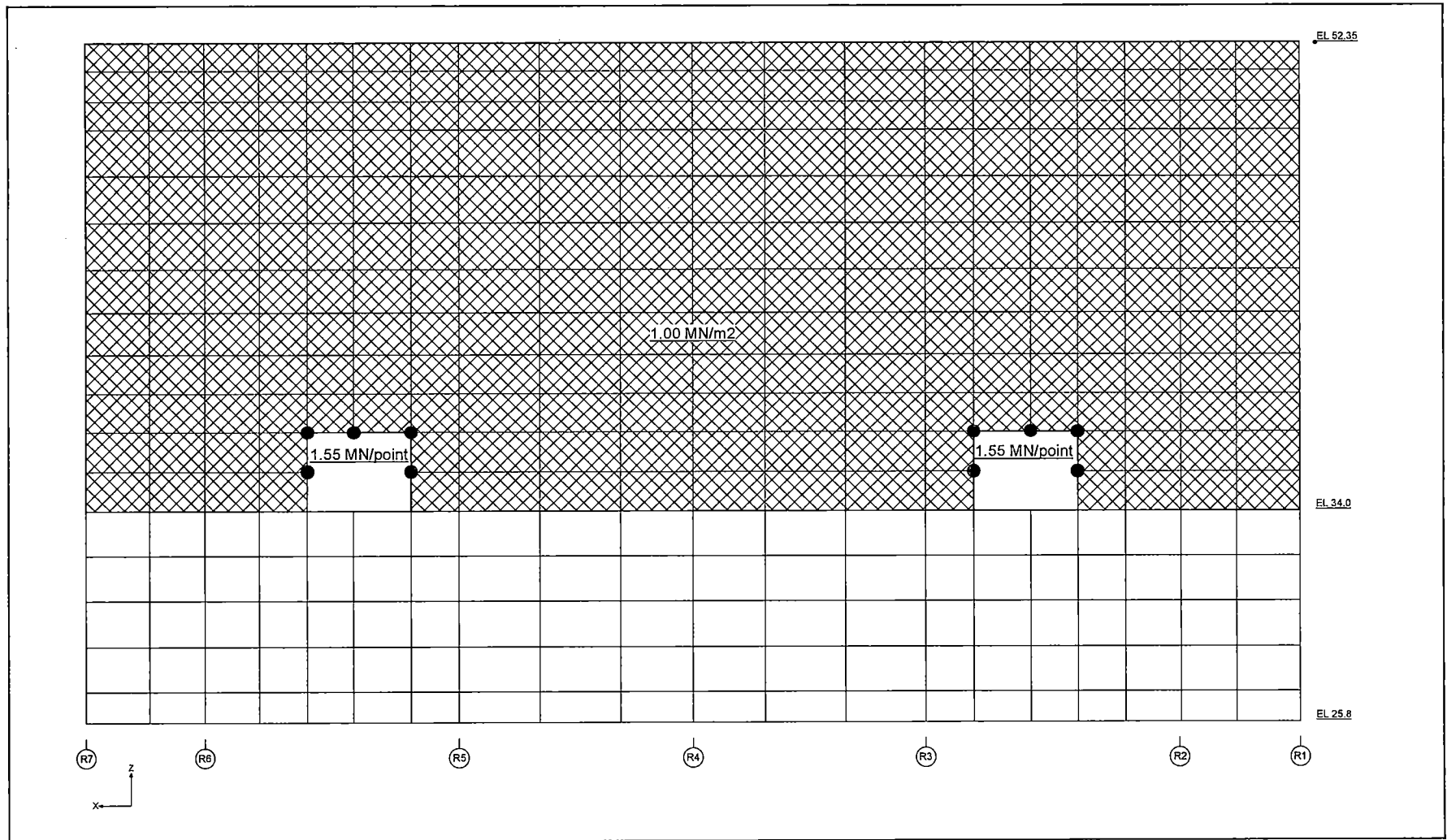


Figure 6.2.3.3-27 HELB Pressure Load (for RB General Rooms: RB Wall)

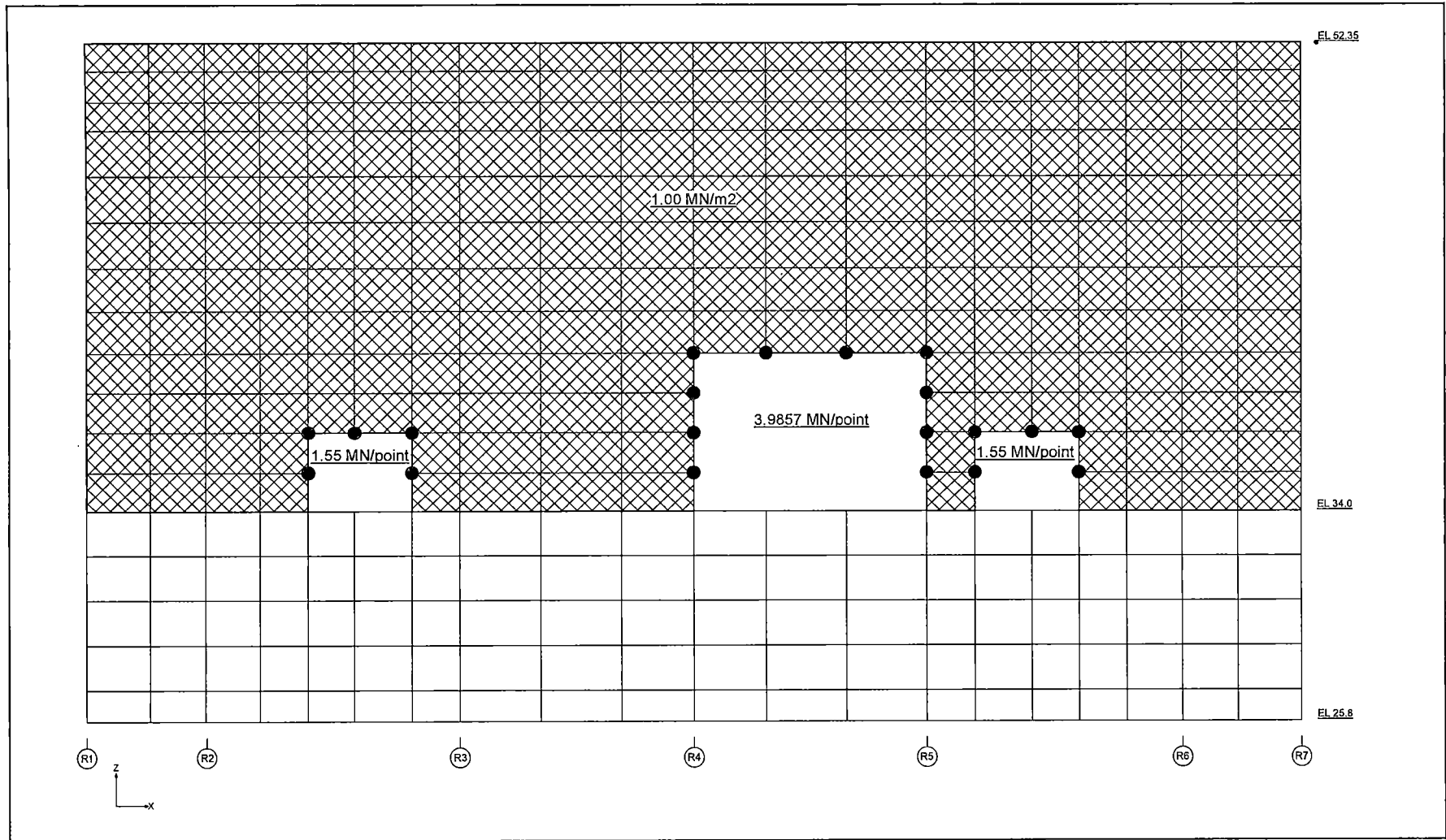


Figure 6.2.3.3-28 HELB Pressure Load (for RB General Rooms: RF Wall)



HITACHI

WG3-U71-ERD-S-0004 SH NO. 361
REV. 0 of 538

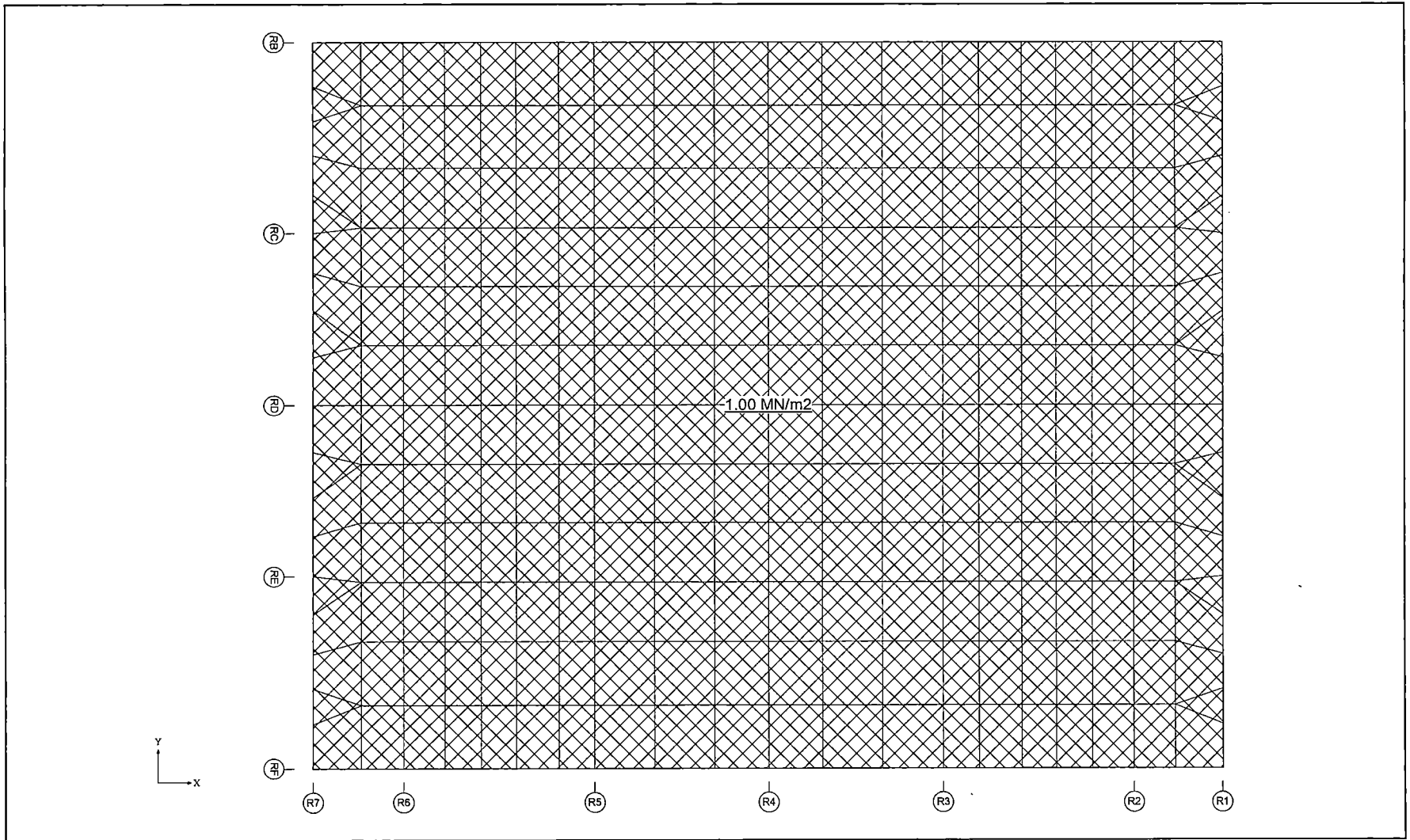


Figure 6.2.3.3-29 HELB Pressure Load (for RB General Rooms: Roof)

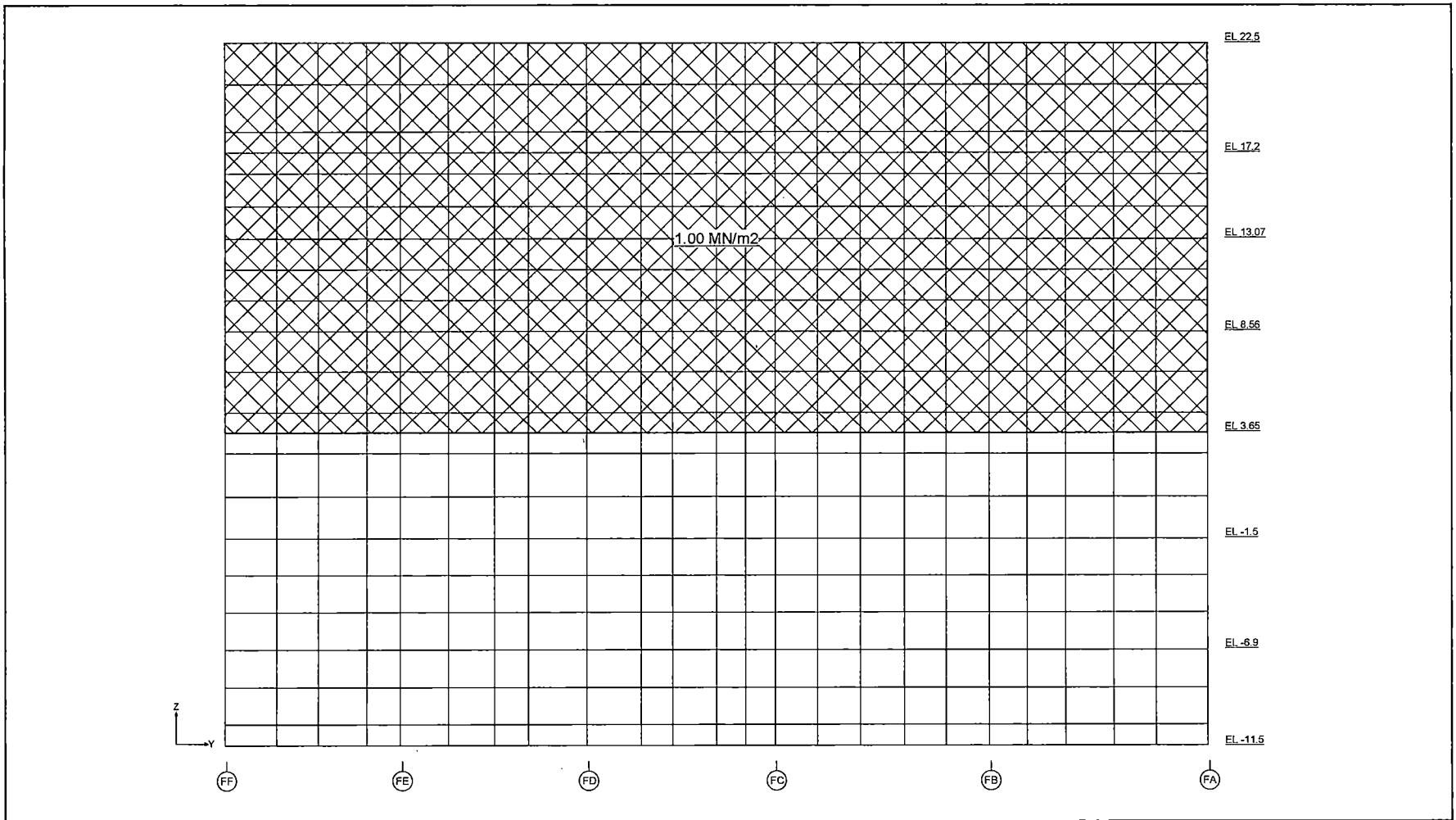


Figure 6.2.3.3-30 HELB Pressure Load (for FB General Rooms: F3 Wall)

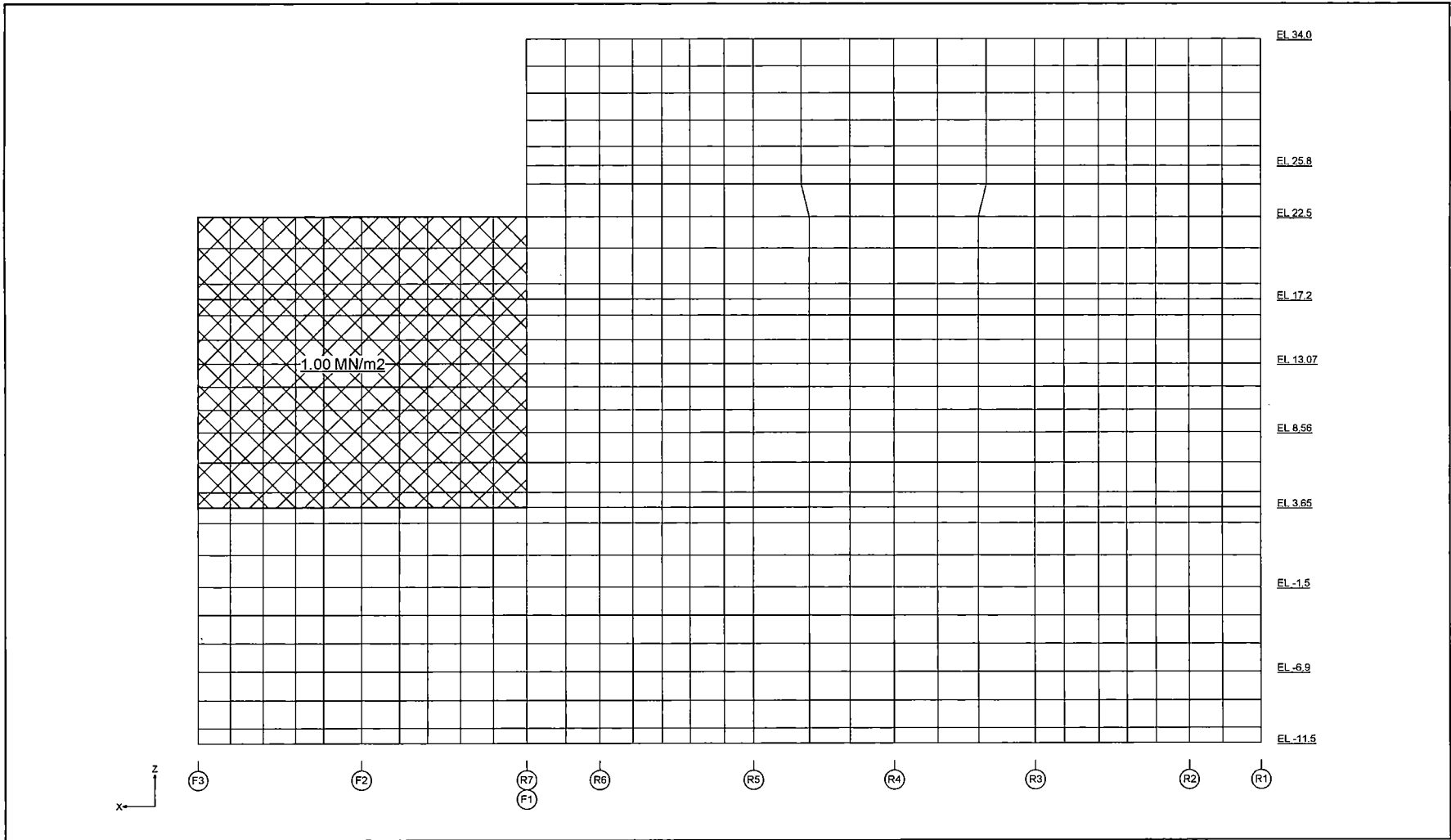


Figure 6.2.3.3-31 HELB Pressure Load (for FB General Rooms: FA Wall)

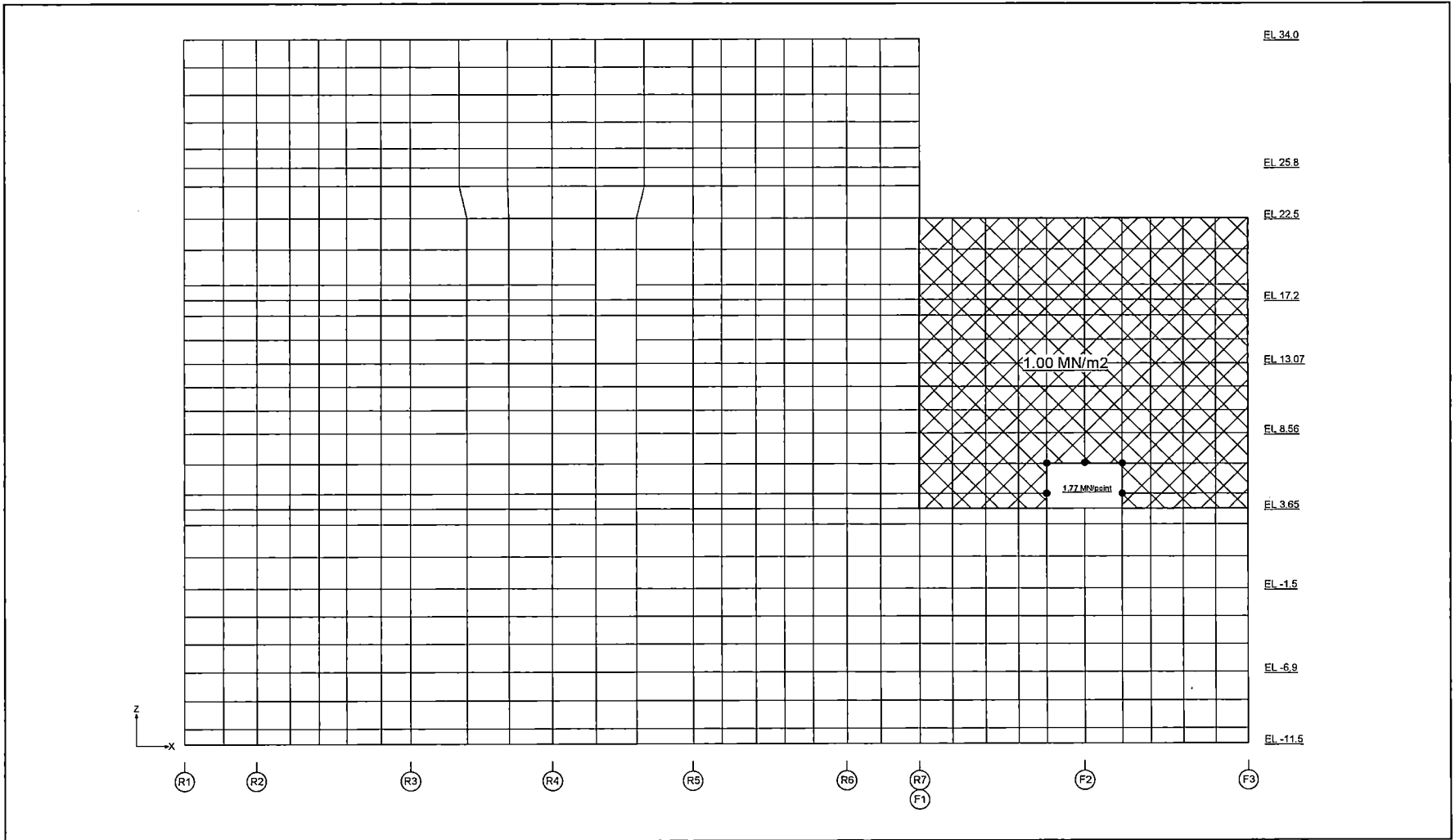


Figure 6.2.3.3-32 HELB Pressure Load (for FB General Rooms: FF Wall)



HITACHI

WG3-U71-ERD-S-0004

SH NO. 365

REV. 0

of 538

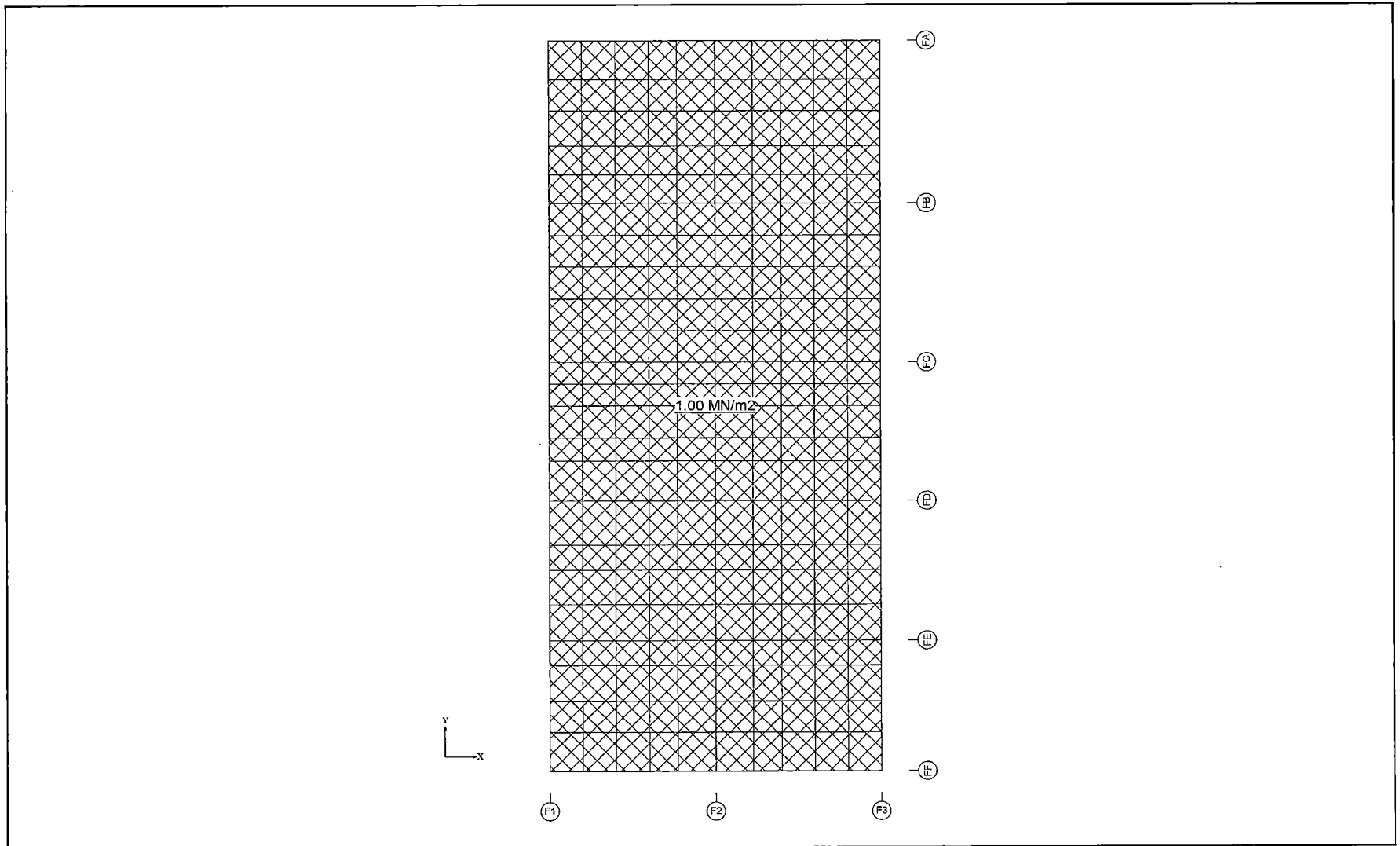


Figure 6.2.3.3-33 HELB Pressure Load (for FB General Rooms: Slab at EL 22500)

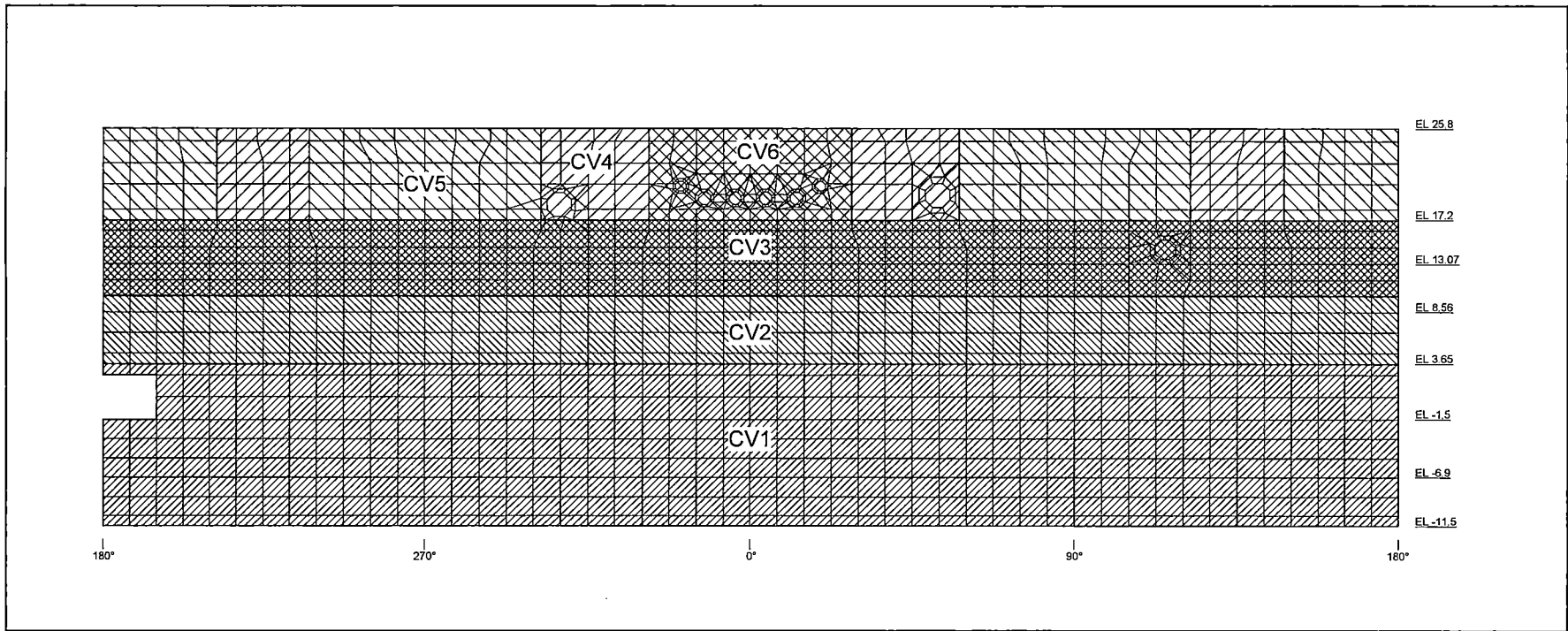


Figure 6.2.3.4-1 Application of Thermal Load on the RCCV Wall (Normal Operation)

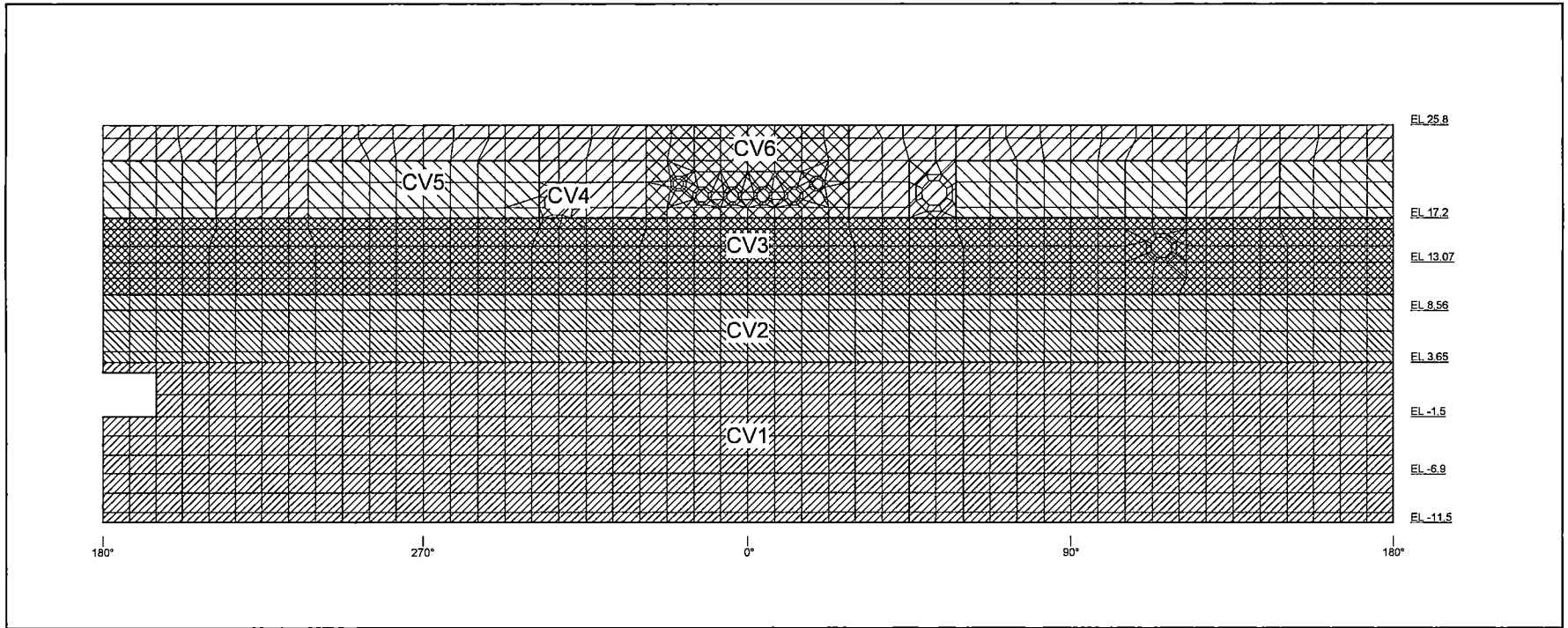


Figure 6.2.3.4-2 Application of Thermal Load on the RCCV Wall (LOCA Condition 1)

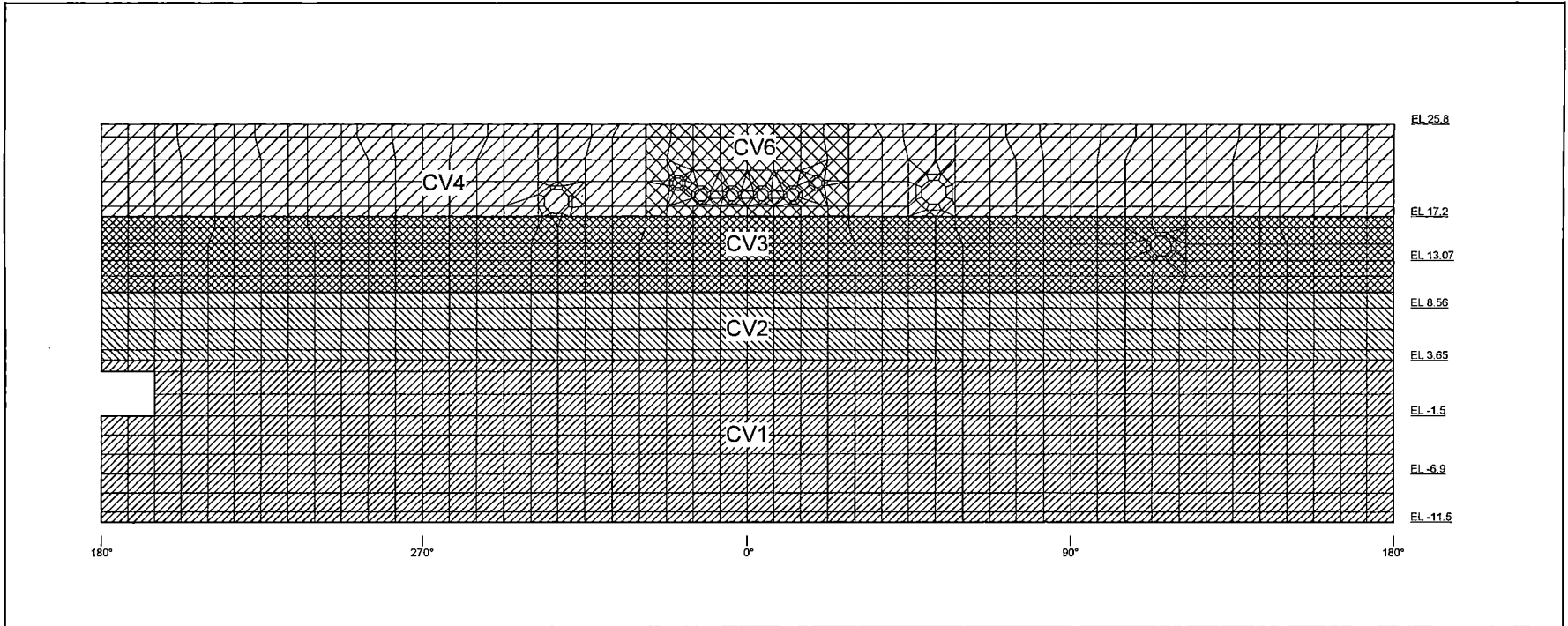


Figure 6.2.3.4-3 Application of Thermal Load on the RCCV Wall (LOCA Condition 2)

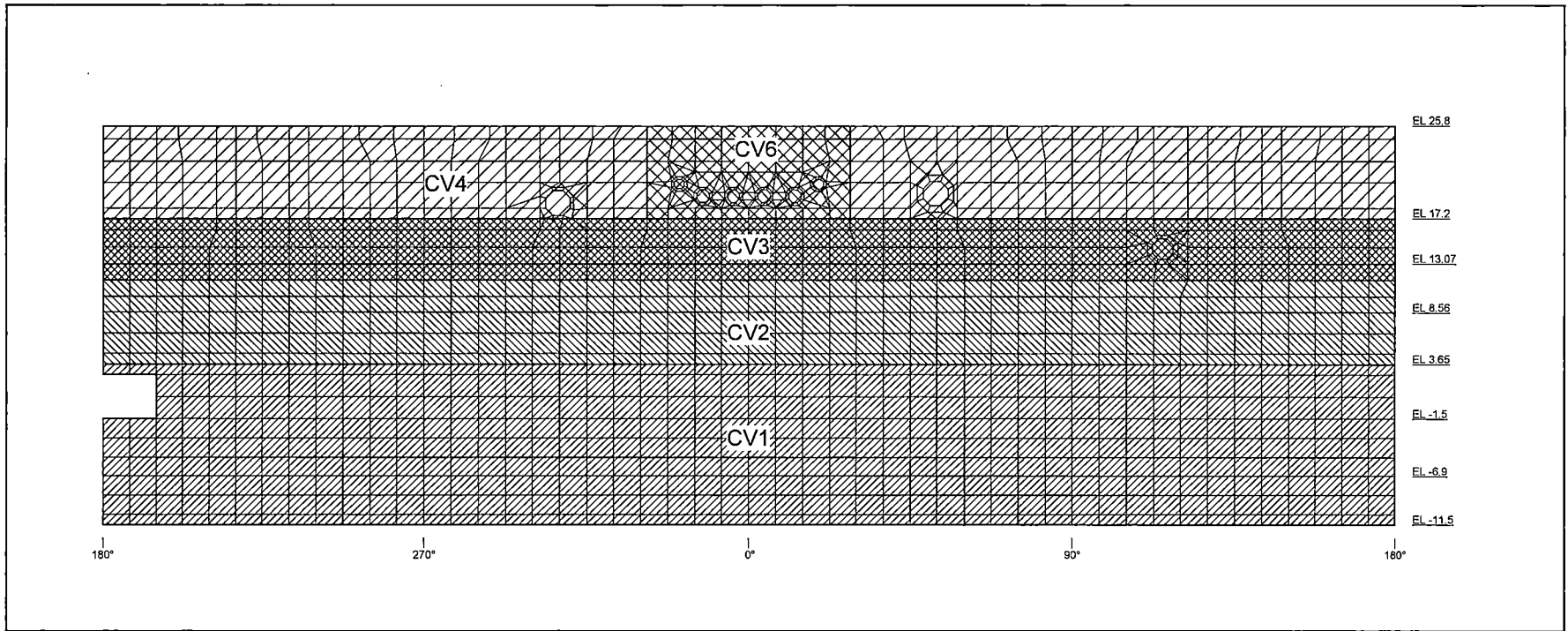


Figure 6.2.3.4-4 Application of Thermal Load on the RCCV Wall (LOCA Flooding Condition 3)

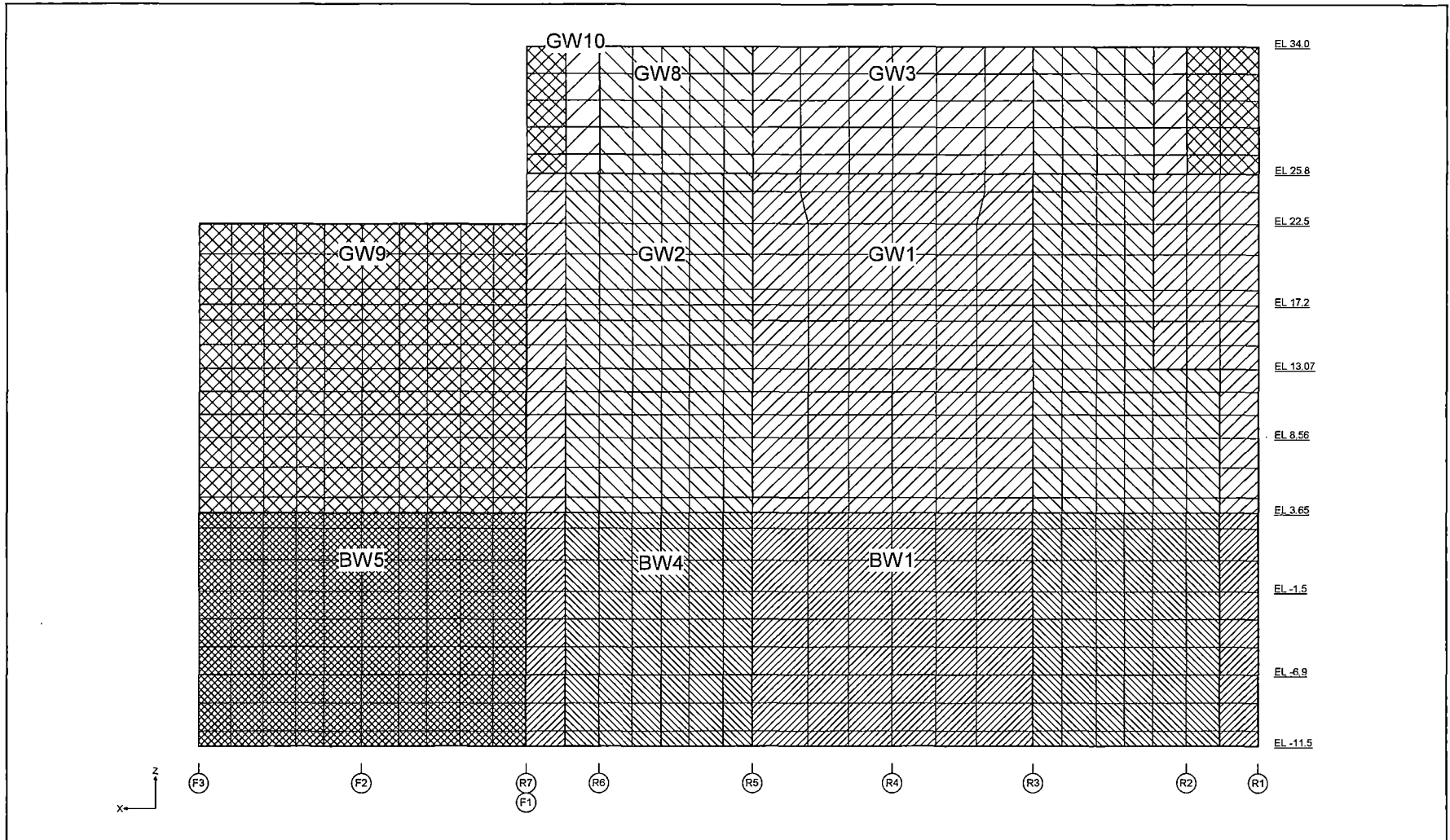


Figure 6.2.3.4-5 Application of Thermal Load on the External Wall (RA/FA)

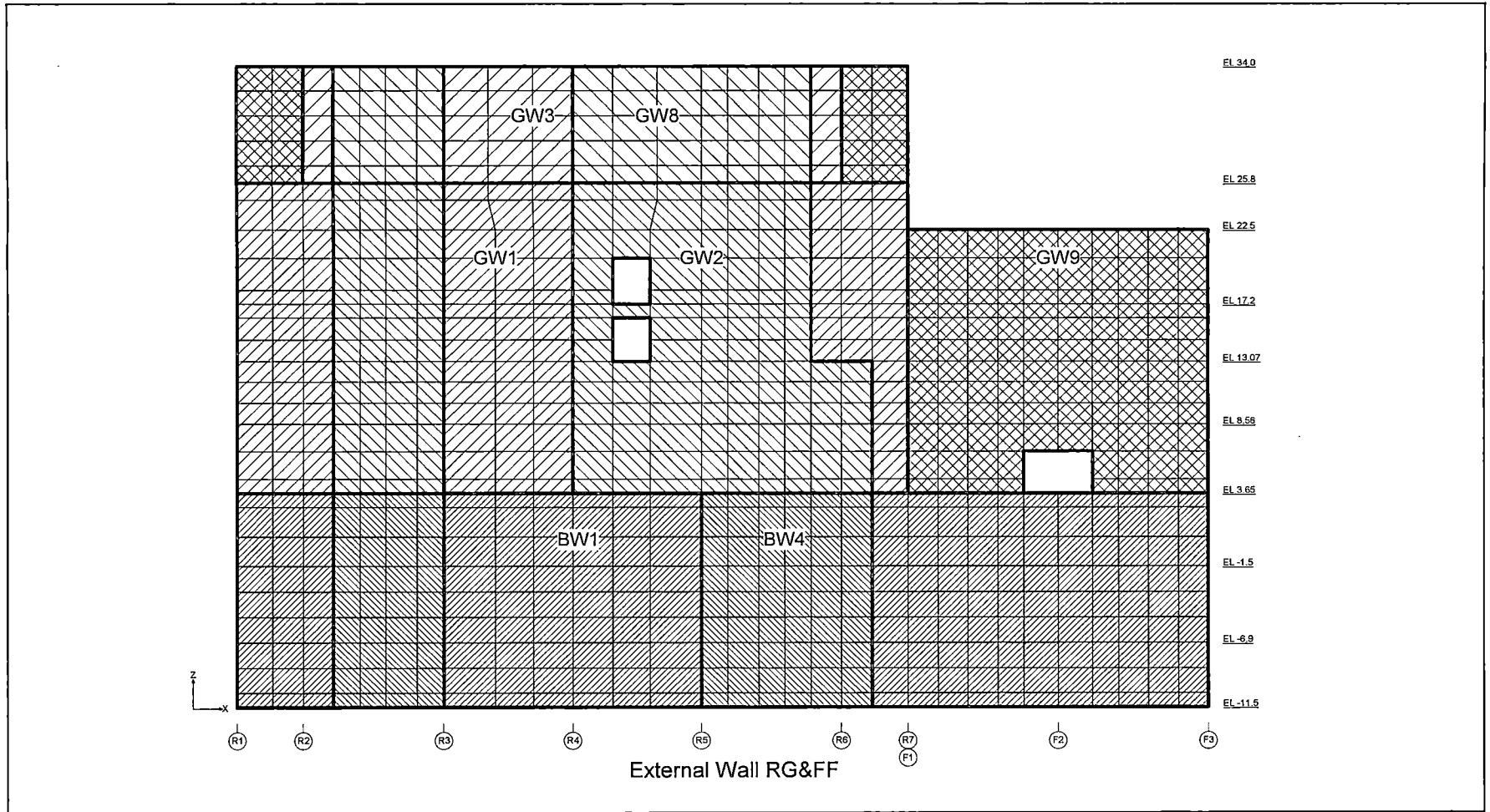


Figure 6.2.3.4-6 Application of Thermal Load on the External Wall (RG/FF)

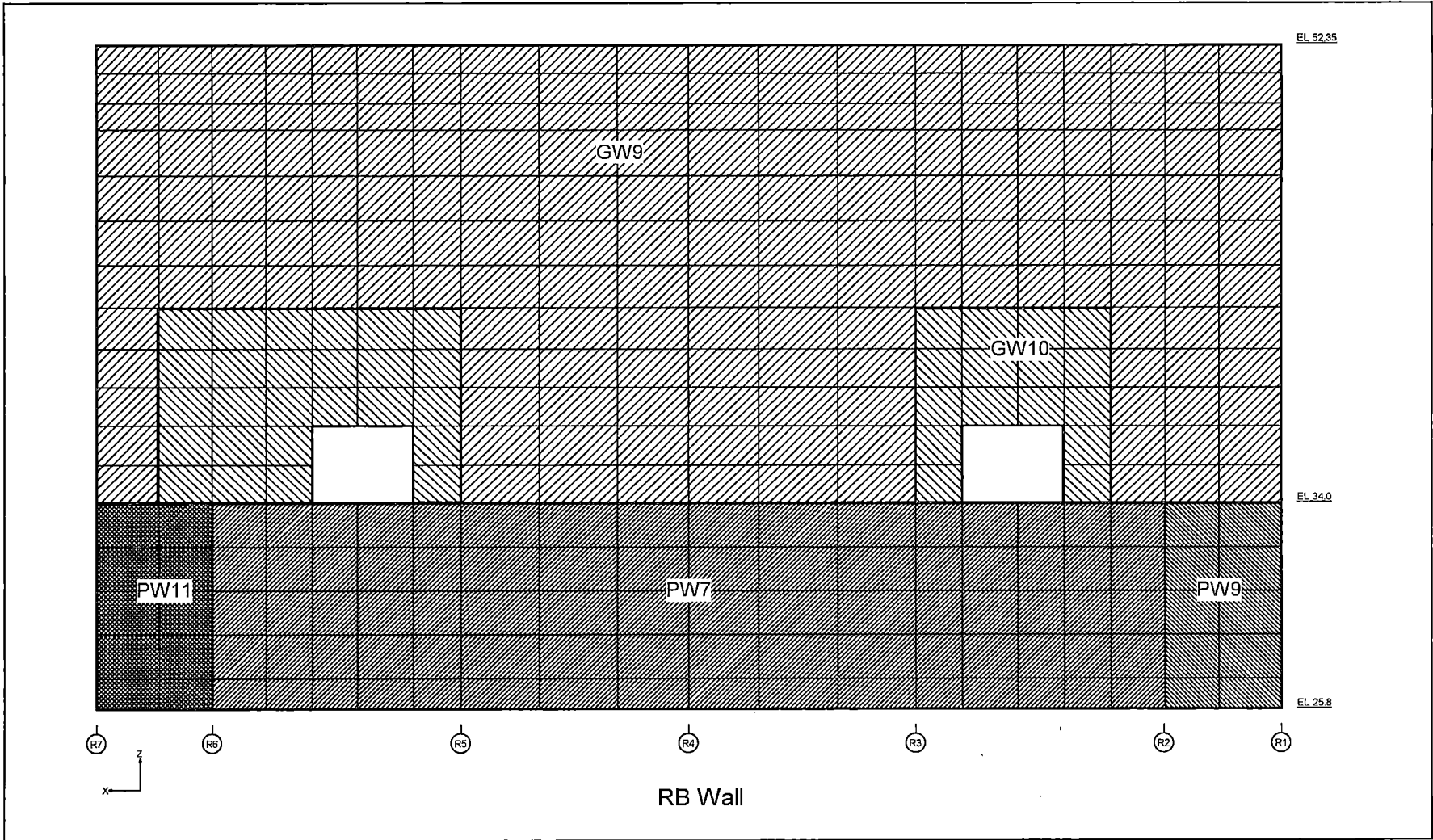


Figure 6.2.3.4-7 Application of Thermal Load on the External Wall (RB)

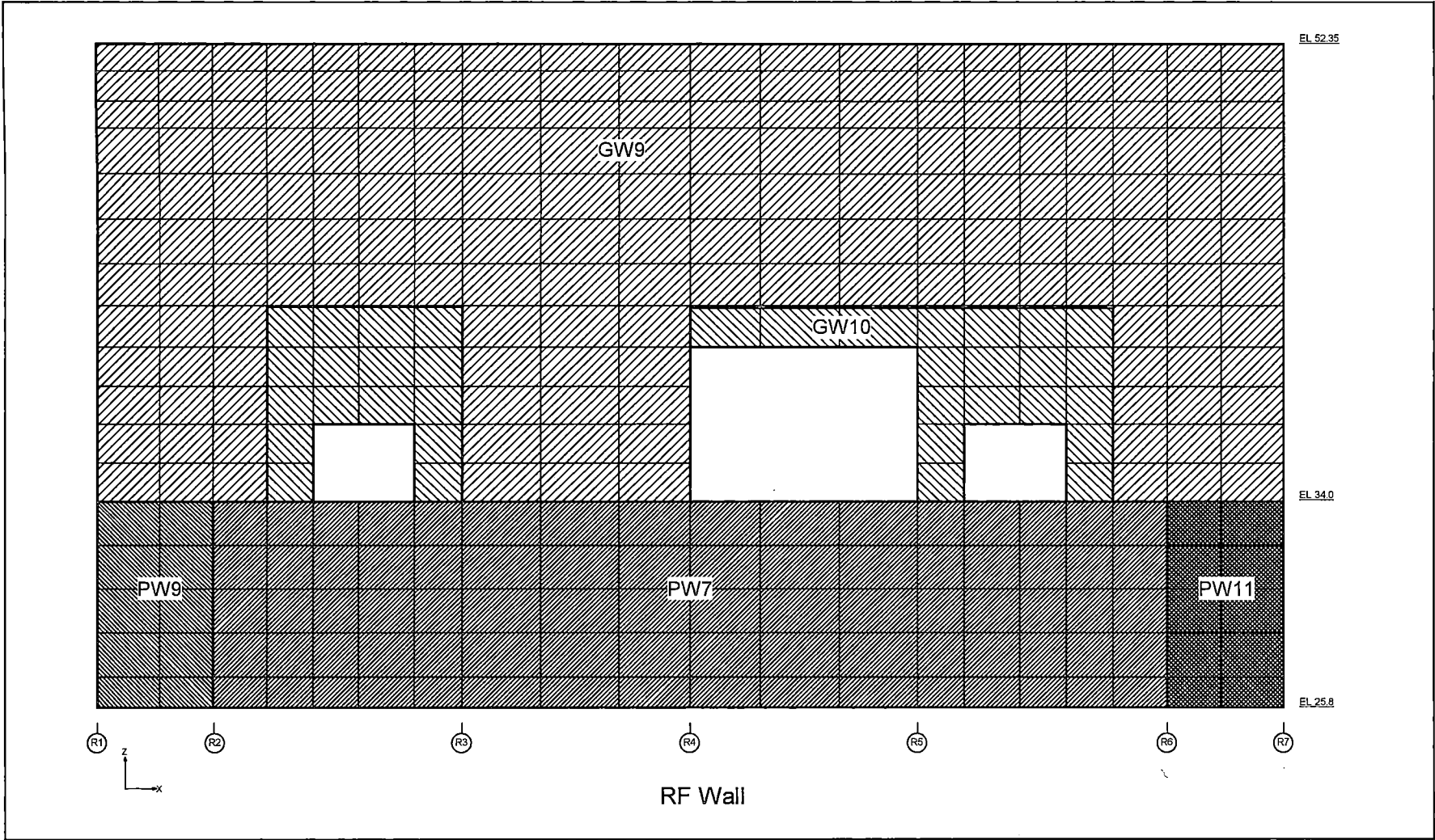


Figure 6.2.3.4-8 Application of Thermal Load on the External Wall (RF)

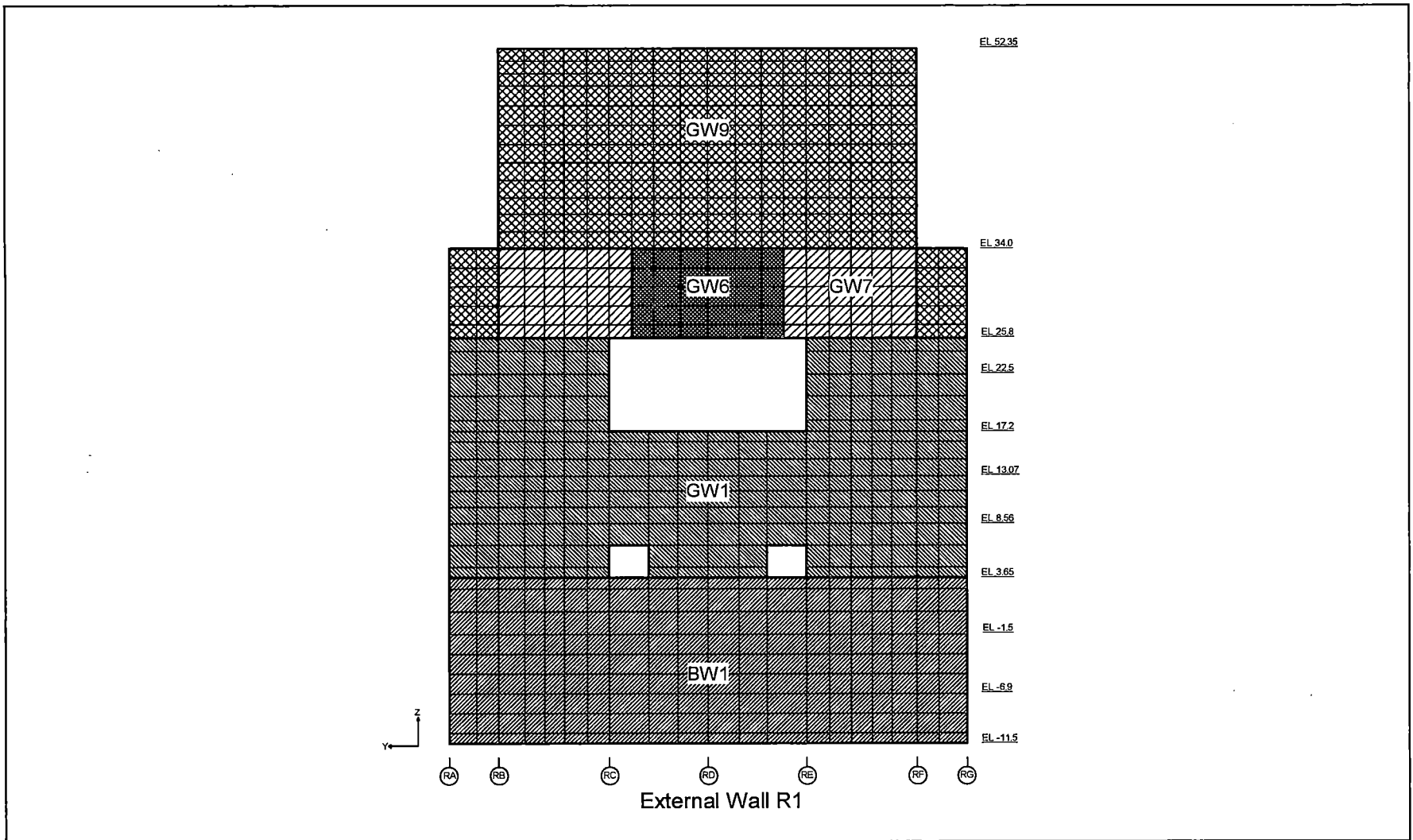


Figure 6.2.3.4-9 Application of Thermal Load on the External Wall (R1)

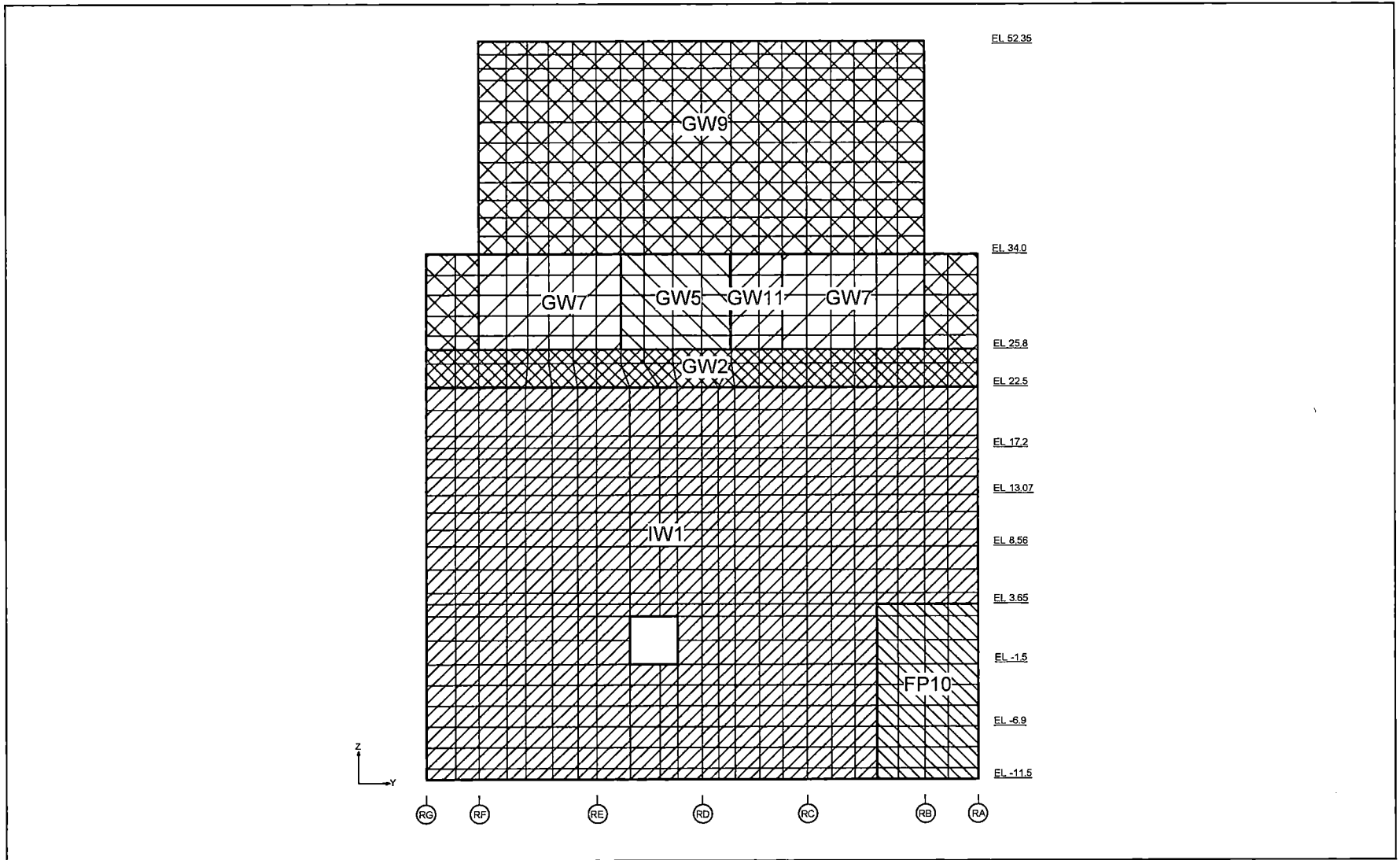


Figure 6.2.3.4-10 Application of Thermal Load on the External Wall (R7/F1)

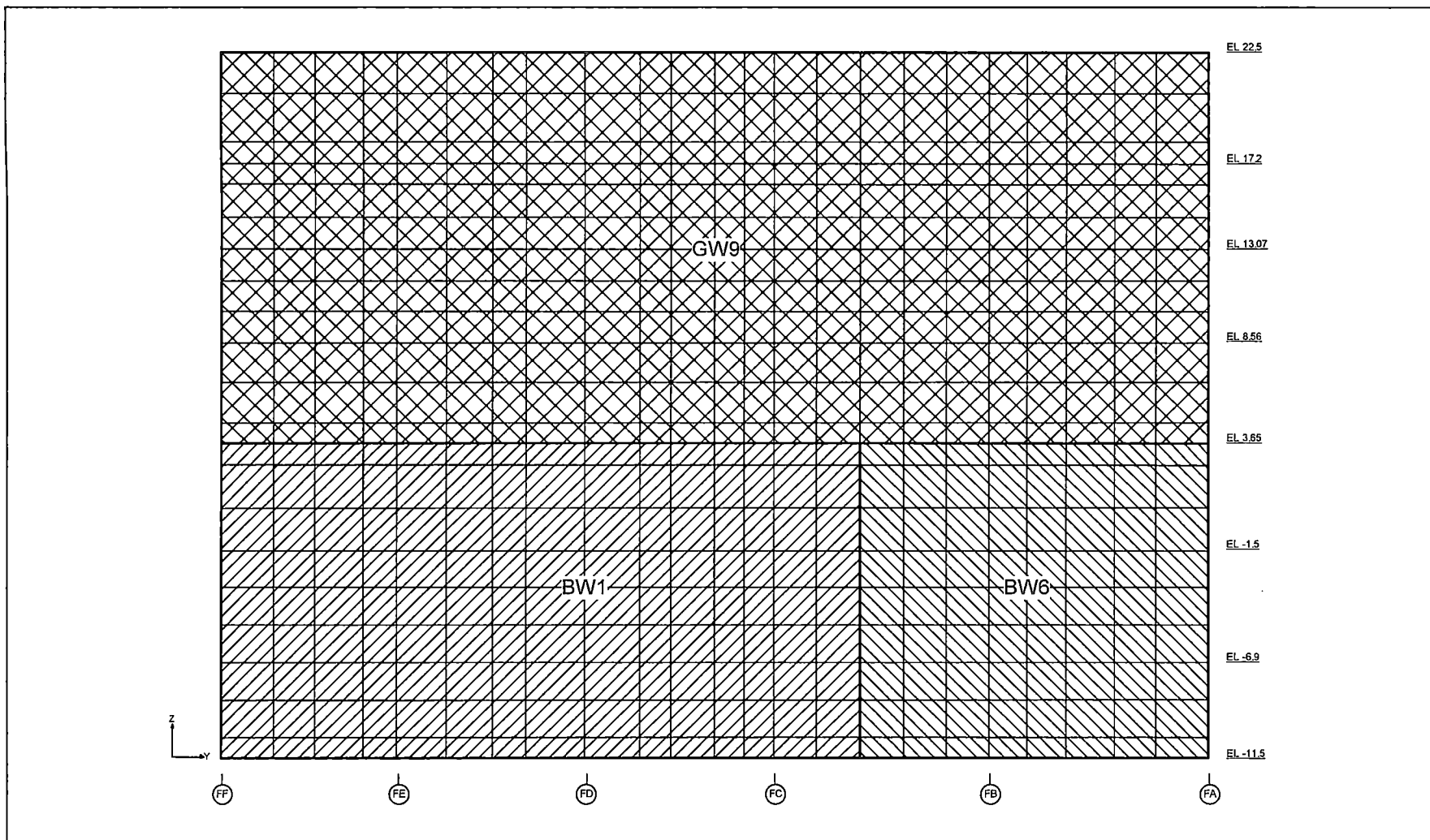


Figure 6.2.3.4-11 Application of Thermal Load on the External Wall (F3)



HITACHI

WG3-U71-ERD-S-0004 SH NO. 377
REV. 0 of 538

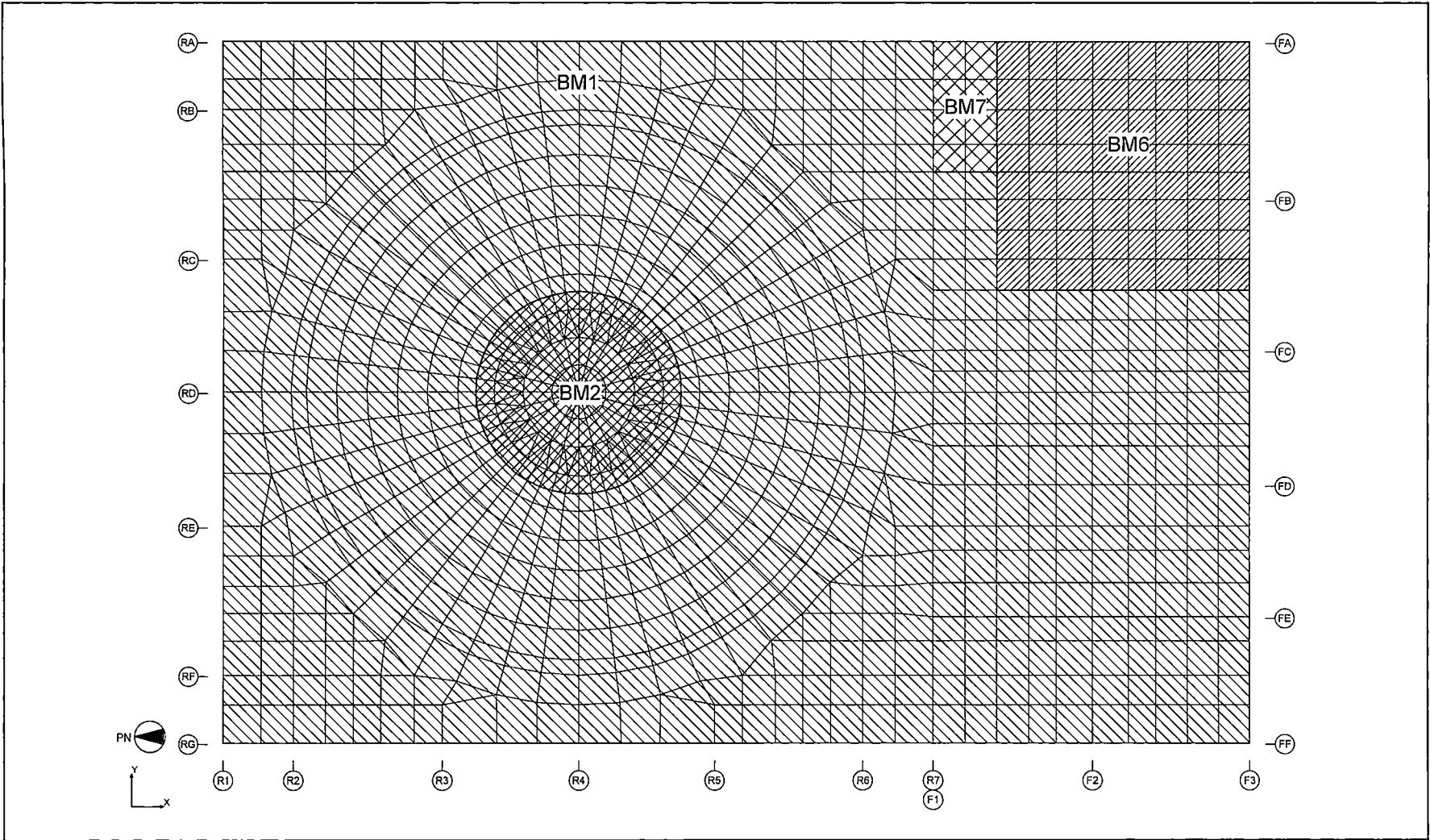


Figure 6.2.3.4-12 Application of Thermal Load on the Basemat

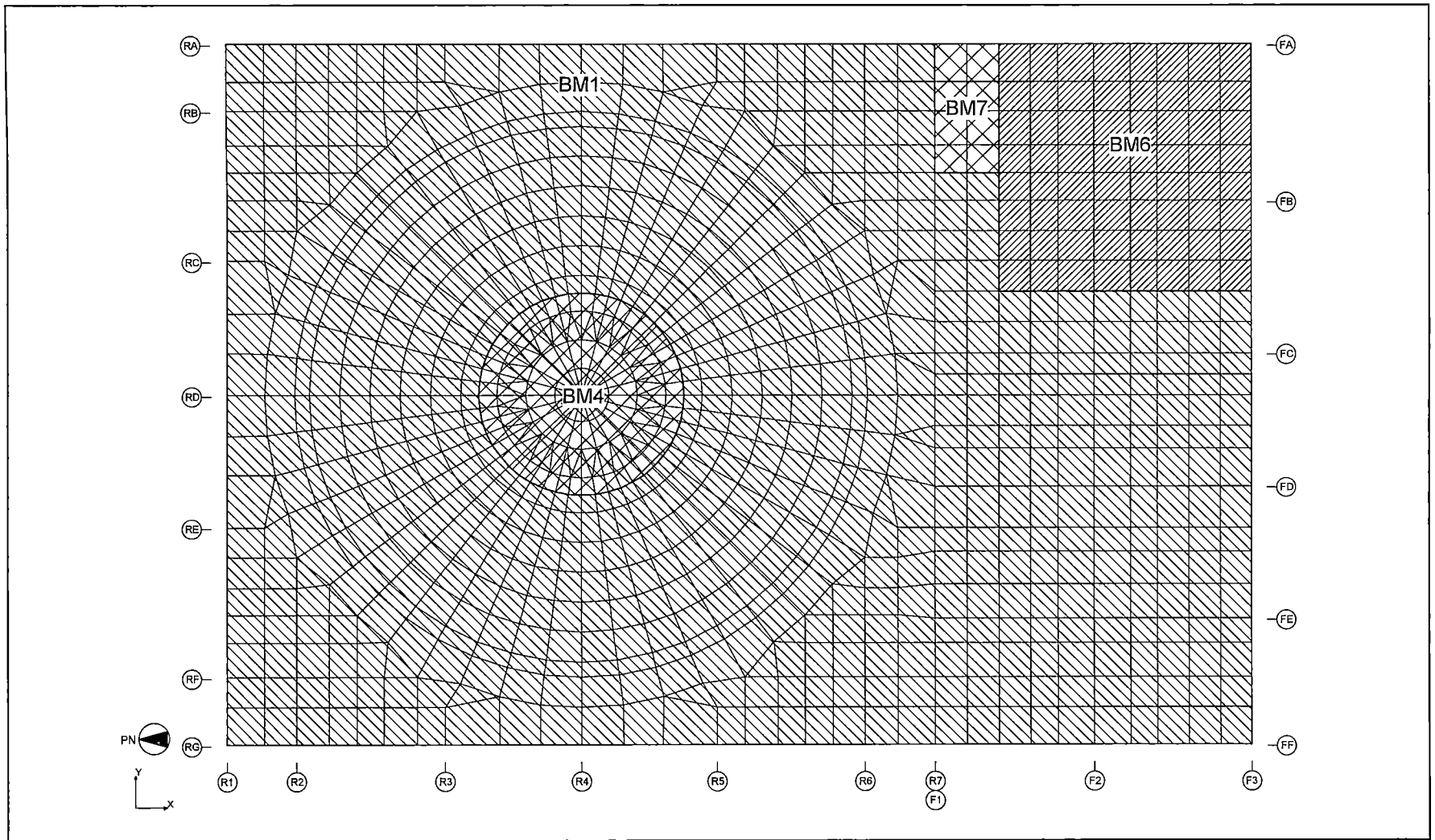


Figure 6.2.3.4-13 Application of Thermal Load on the Basemat (during LOCA Flooding)

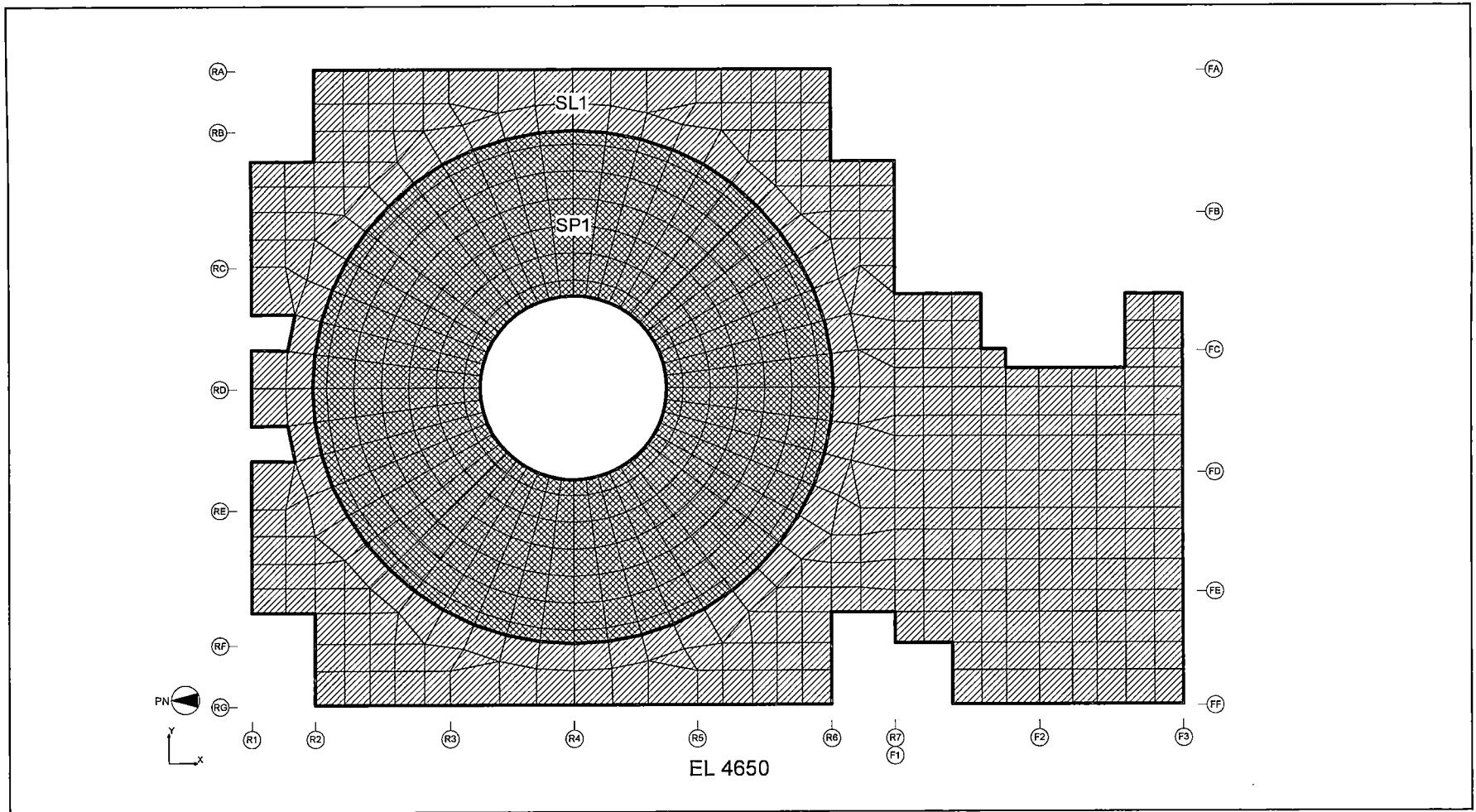


Figure 6.2.3.4-14 Application of Thermal Load on the Slab (EL 4,650)



HITACHI

WG3-U71-ERD-S-0004 SH NO. 380
REV. 0 of 538

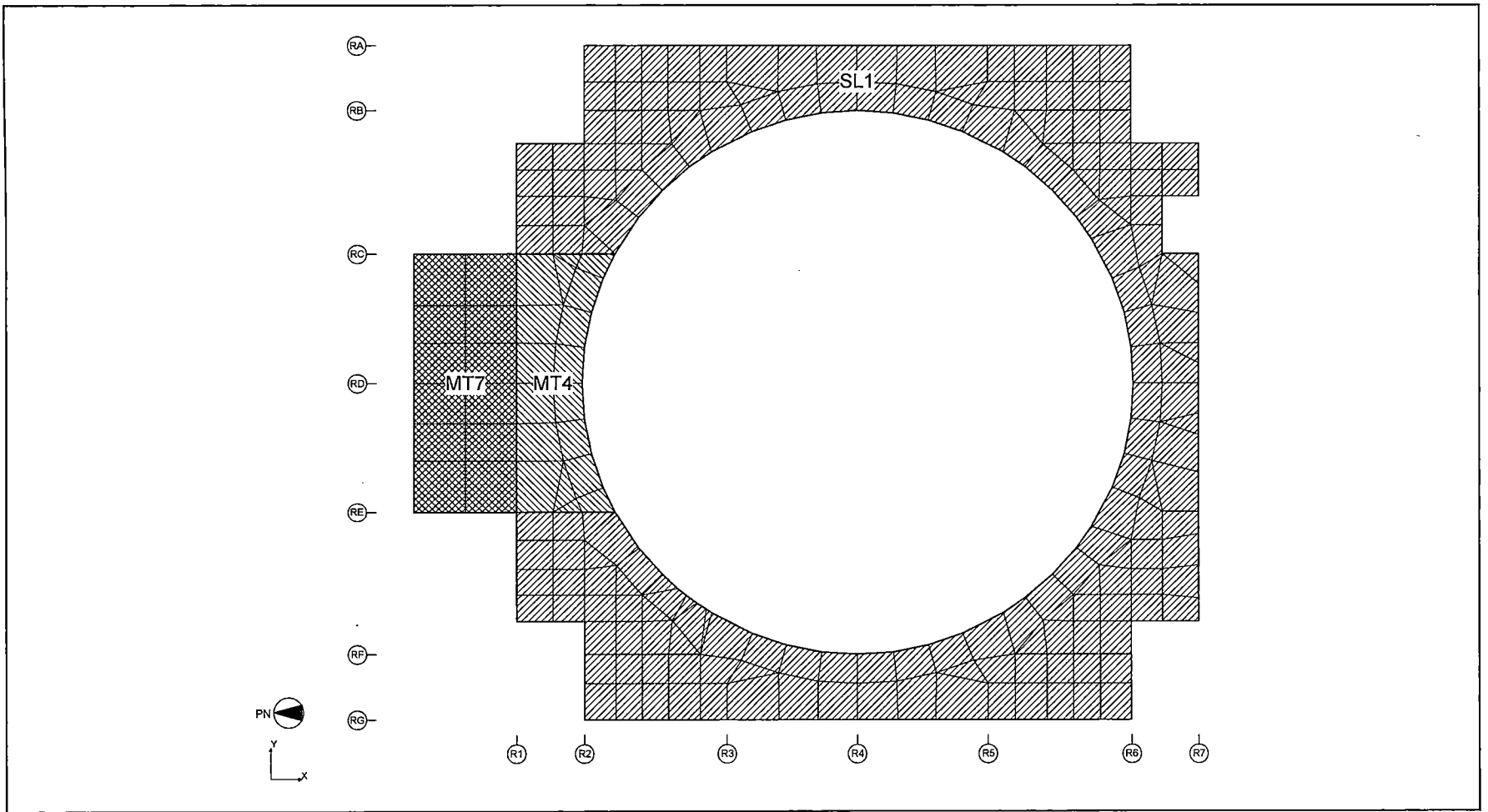


Figure 6.2.3.4-15 Application of Thermal Load on the Slab (EL 17,500)

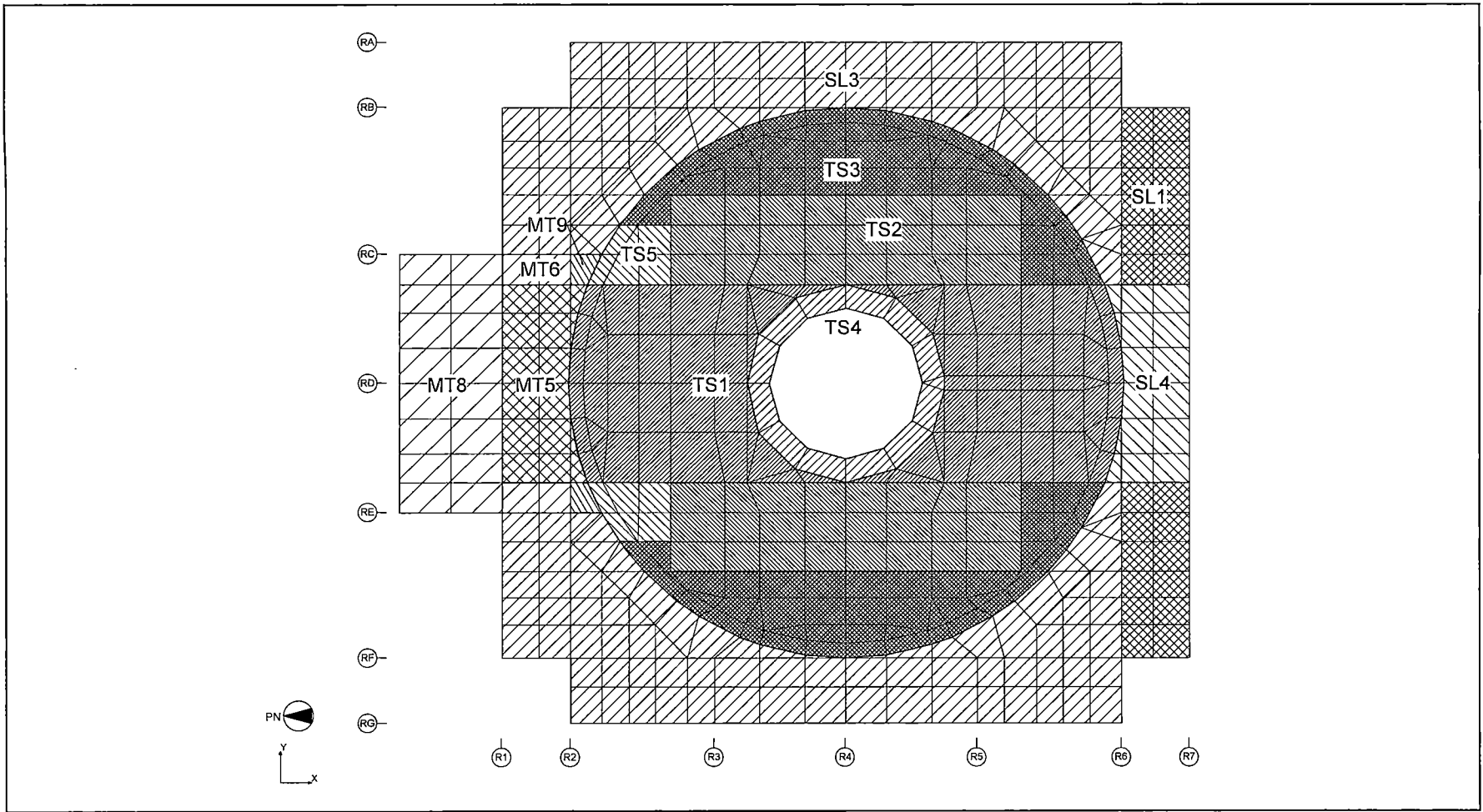


Figure 6.2.3.4-16 Application of Thermal Load on the Slab (EL 27,000)

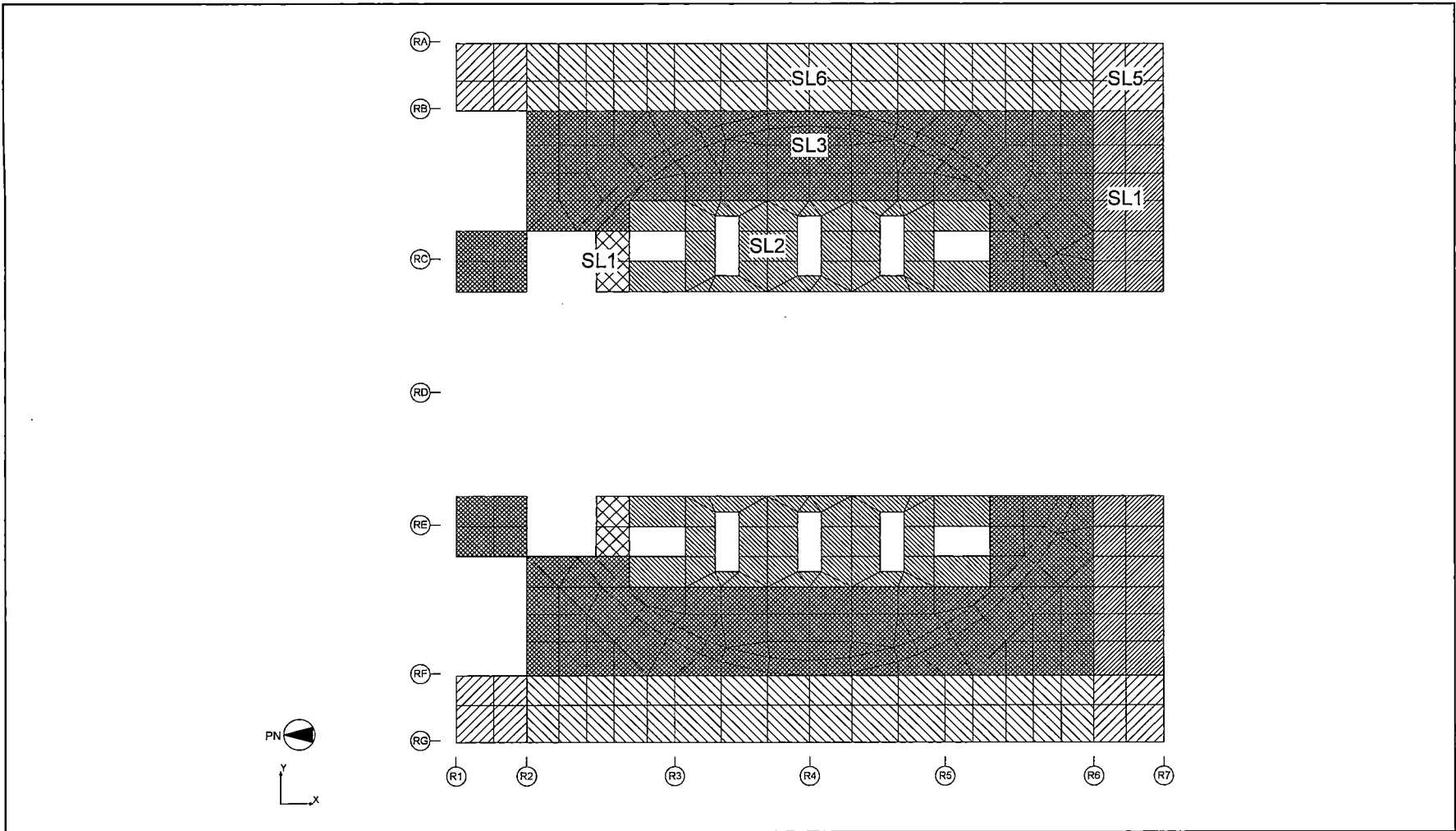


Figure 6.2.3.4-17 Application of Thermal Load on the Slab (EL 34,000)



HITACHI

WG3-U71-ERD-S-0004 SH NO. 383
REV. 0 of 538

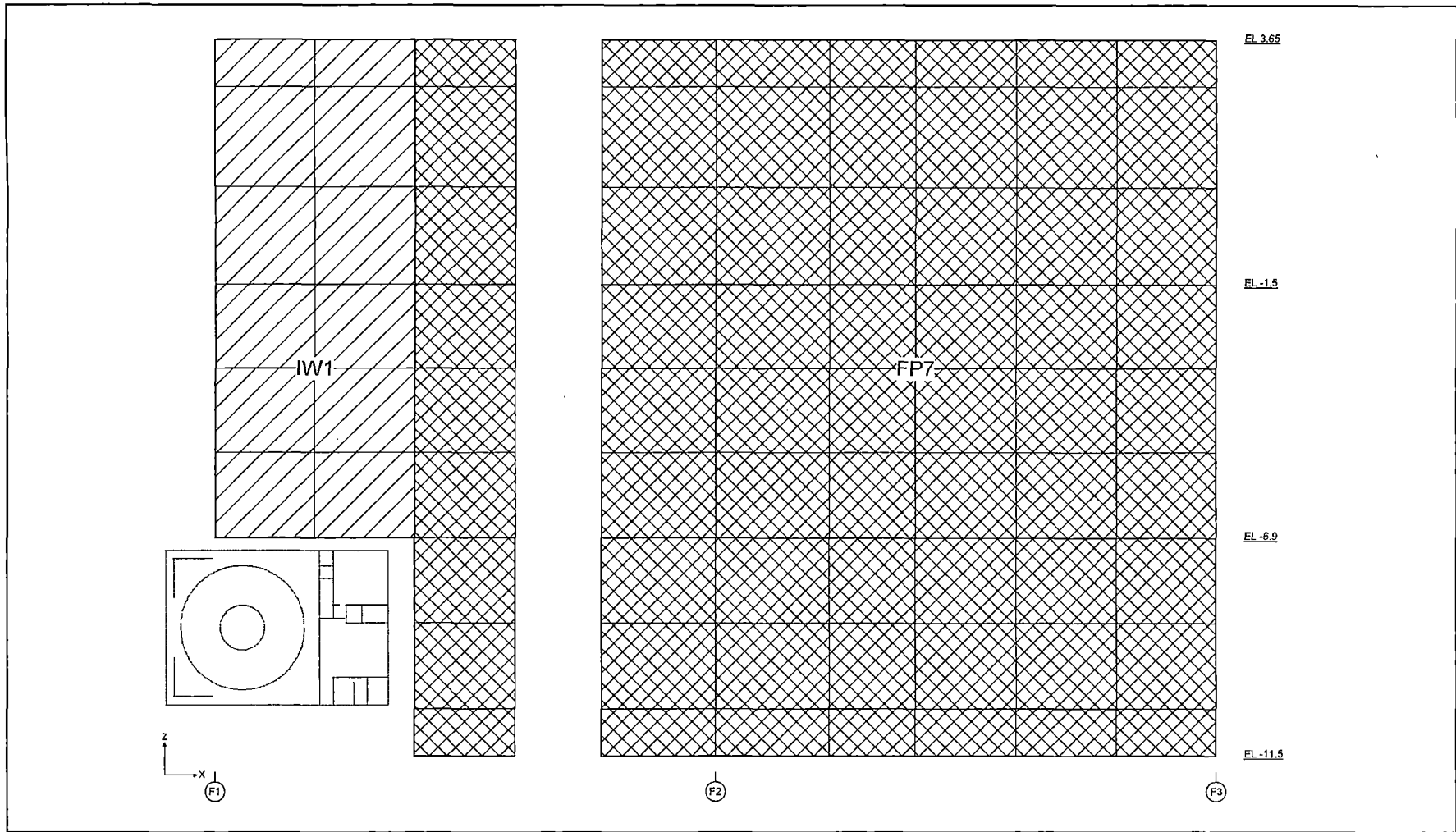


Figure 6.2.3.4-18 Application of Thermal Load on the Spent Fuel Pool Wall-1

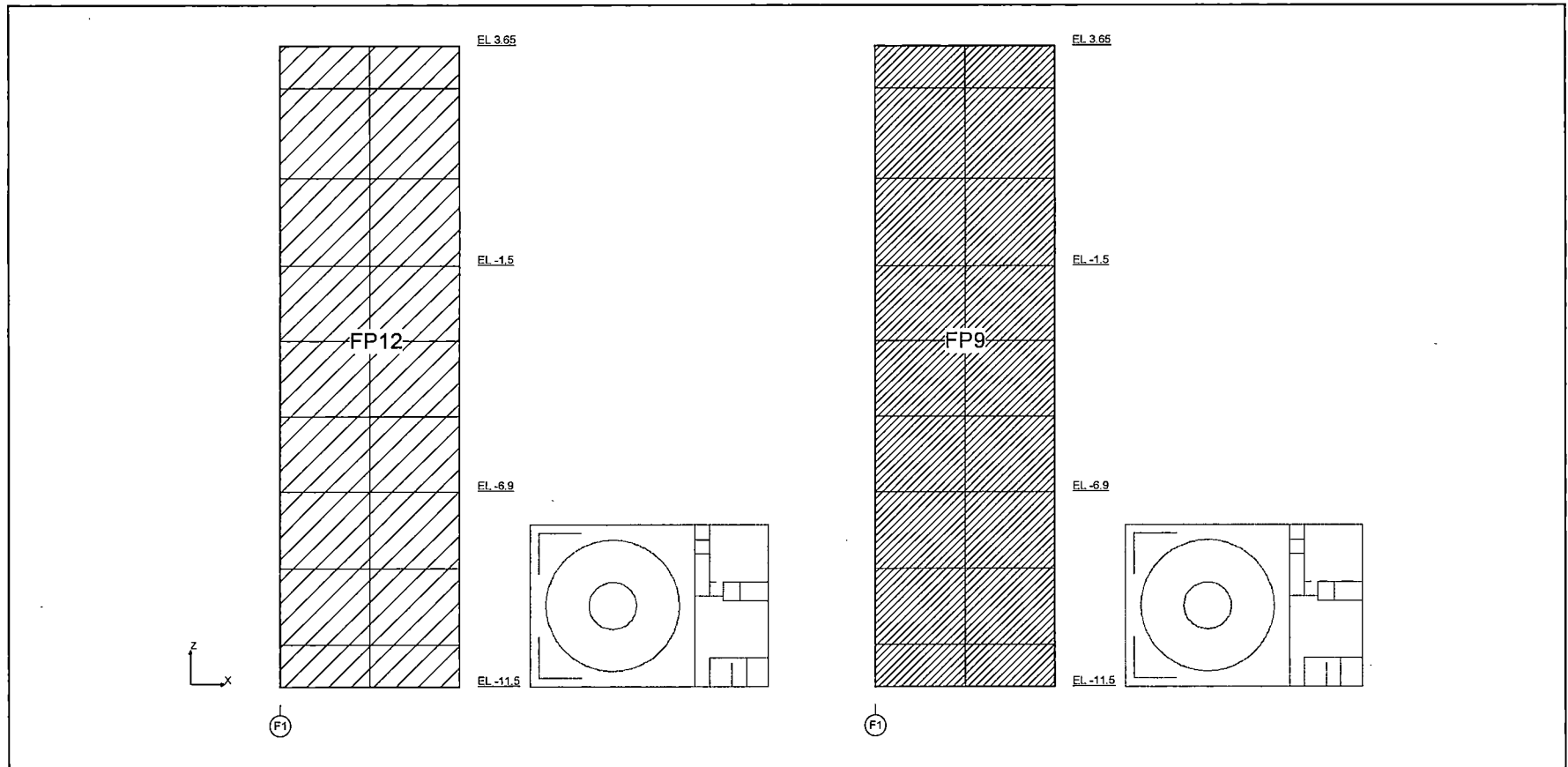


Figure 6.2.3.4-19 Application of Thermal Load on the Spent Fuel Pool Wall-2

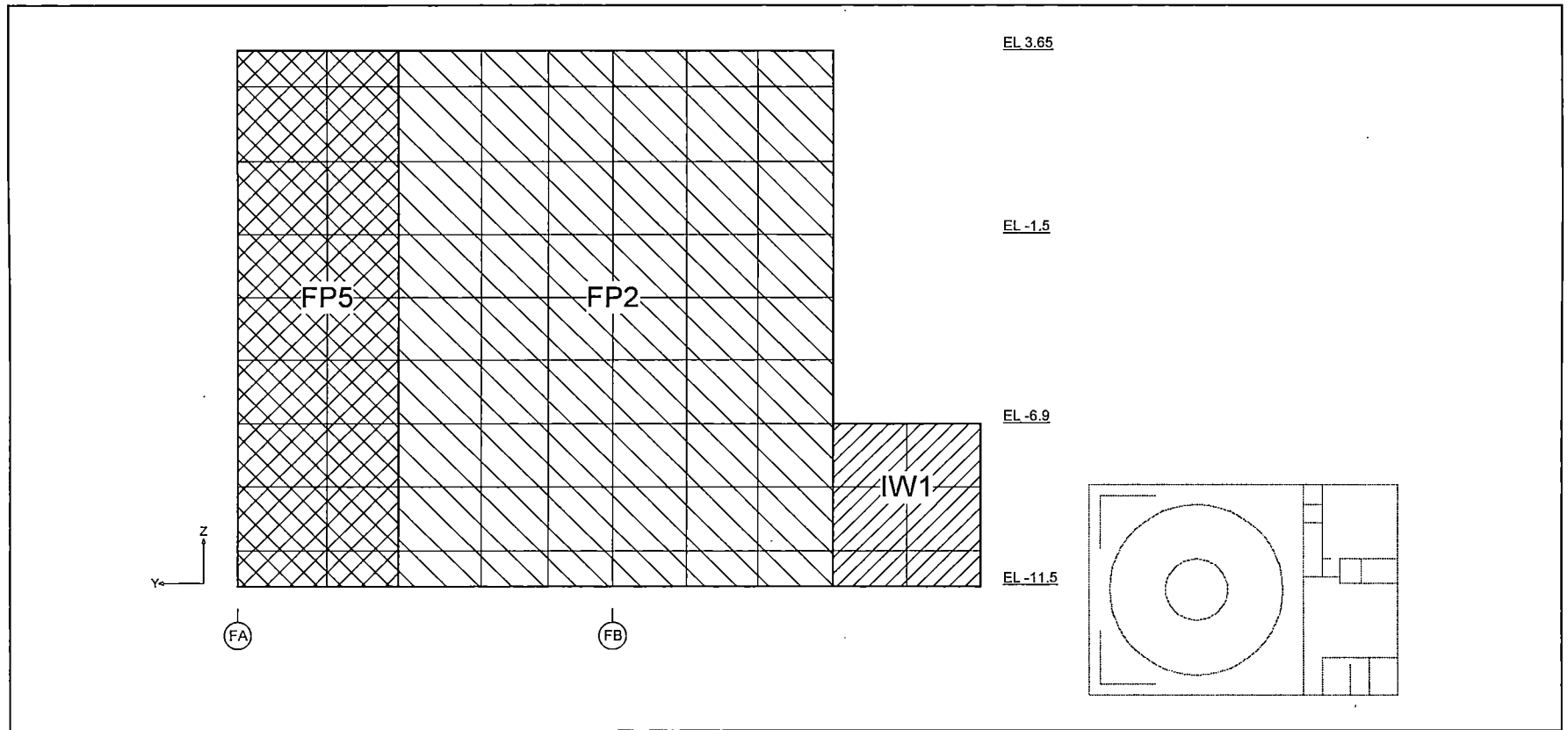


Figure 6.2.3.4-20 Application of Thermal Load on the Spent Fuel Pool Wall-3

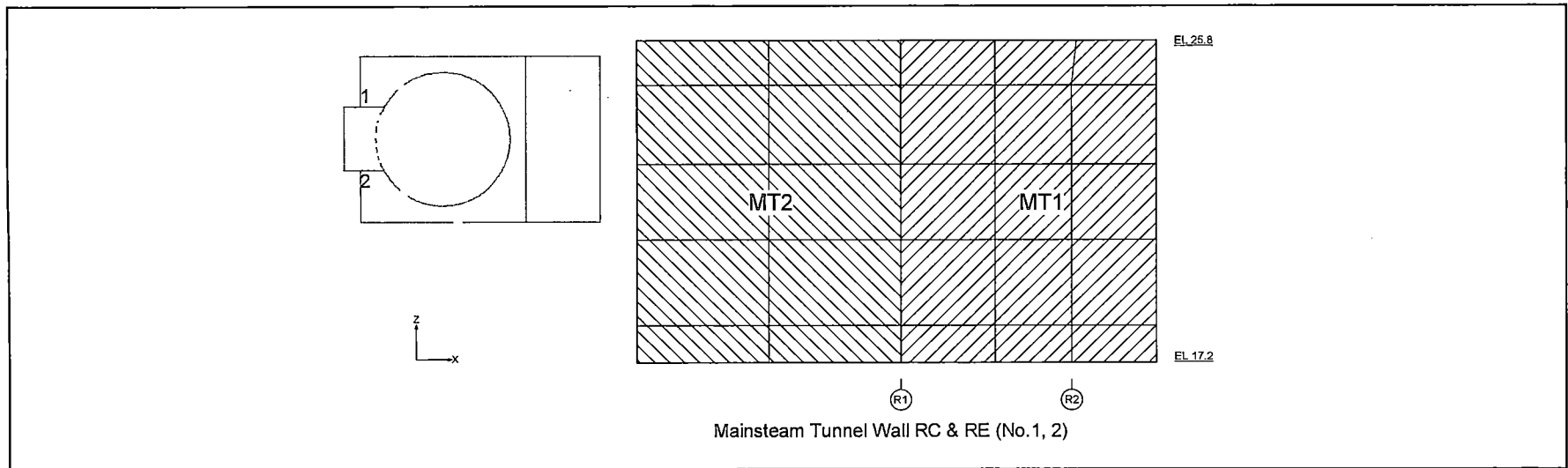


Figure 6.2.3.4-21 Application of Thermal Load on the MS Tunnel Wall

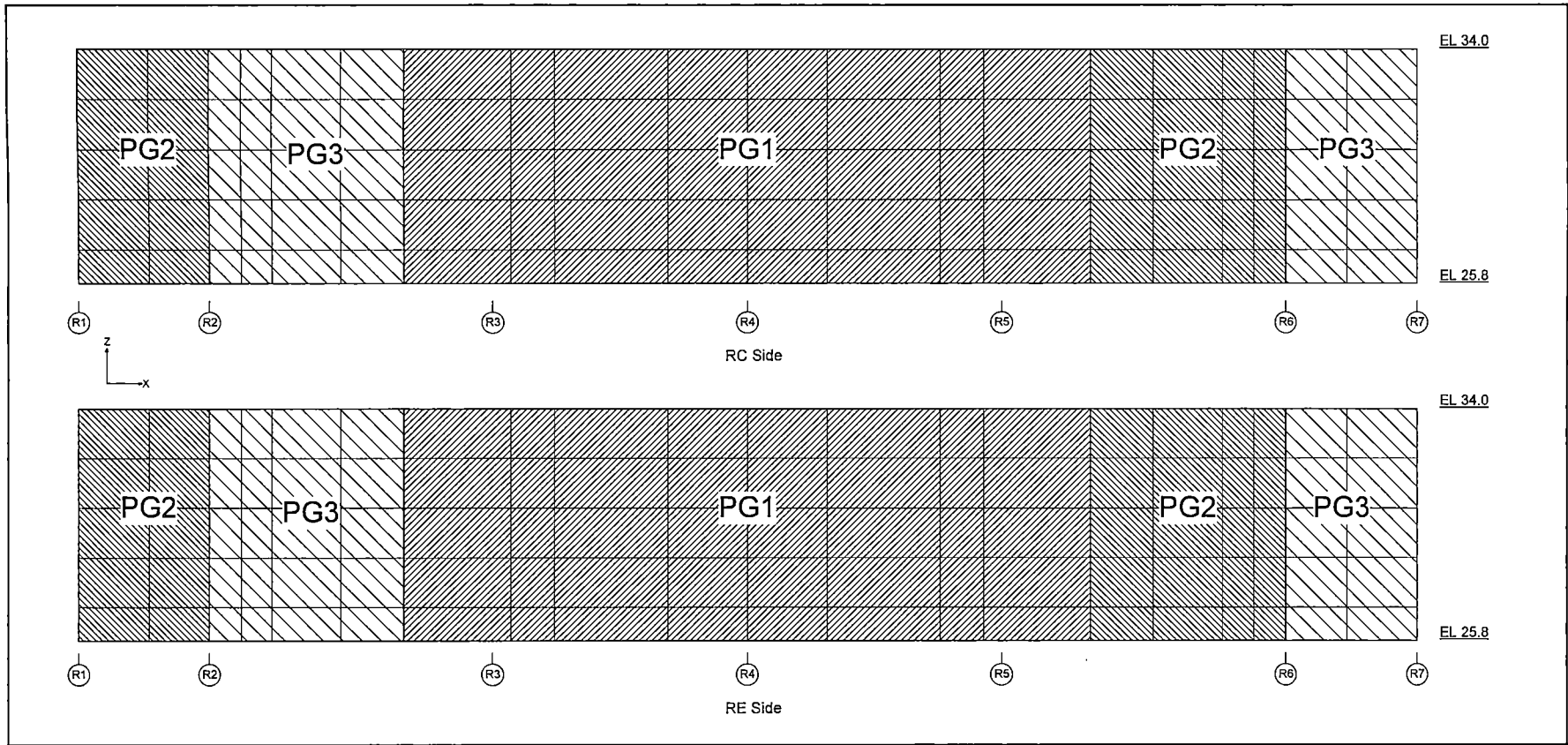


Figure 6.2.3.4-22 Application of Thermal Load on the Pool Girder

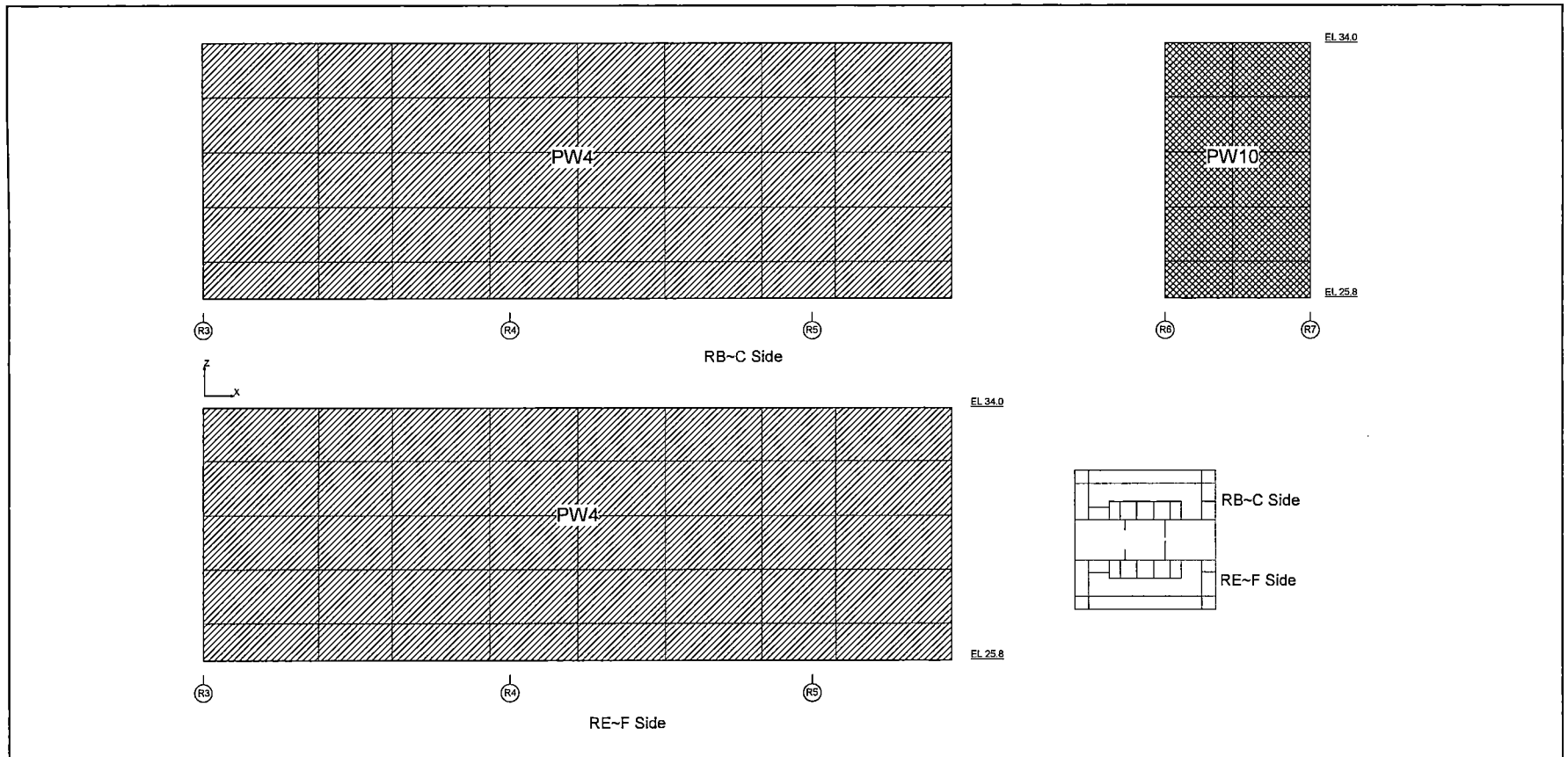


Figure 6.2.3.4-23 Application of Thermal Load on the IC/PCCS Pool Wall-1 (1)

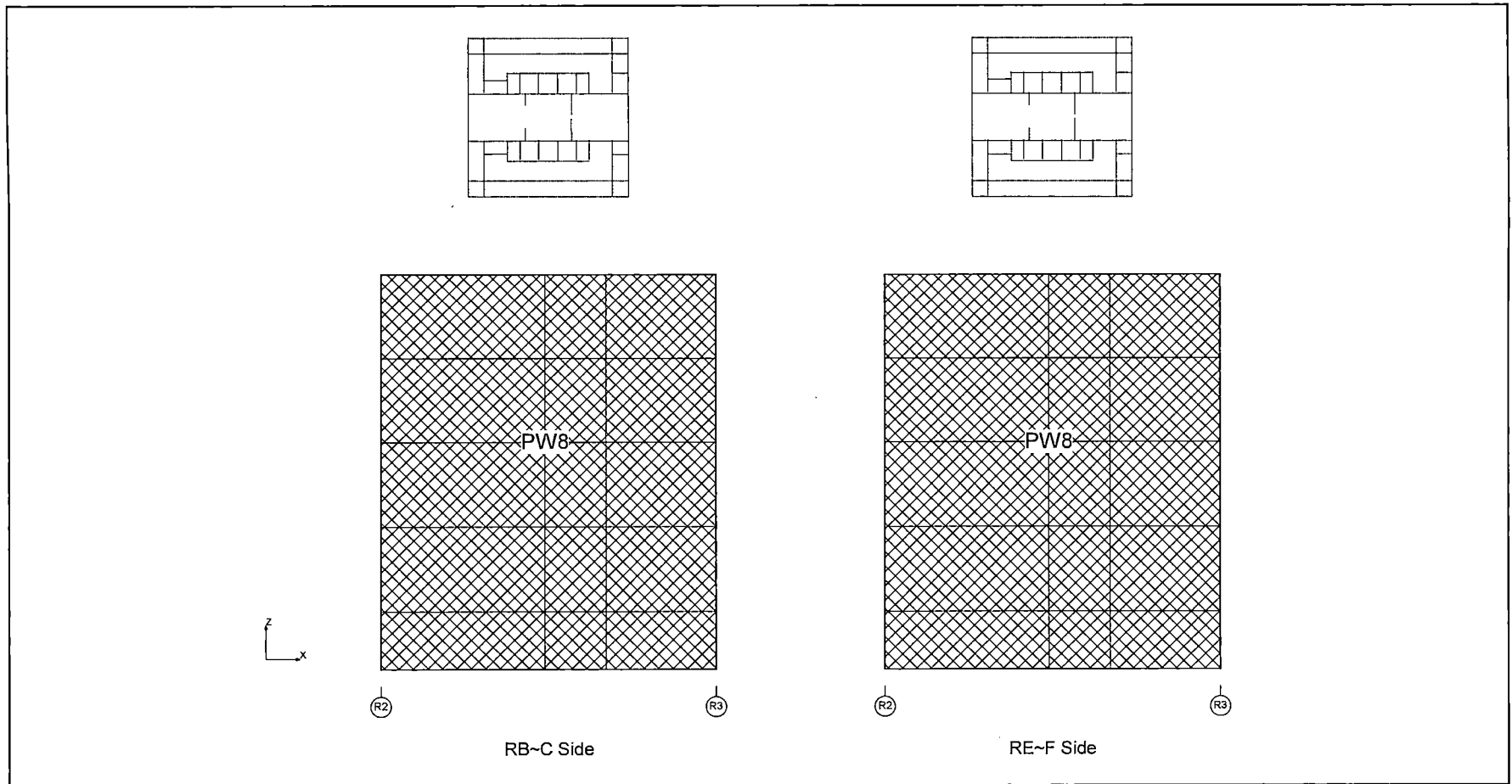


Figure 6.2.3.4-24 Application of Thermal Load on the IC/PCCS Pool Wall-1(2)



HITACHI

WG3-U71-ERD-S-0004 SH NO. 390
REV. 0 of 538

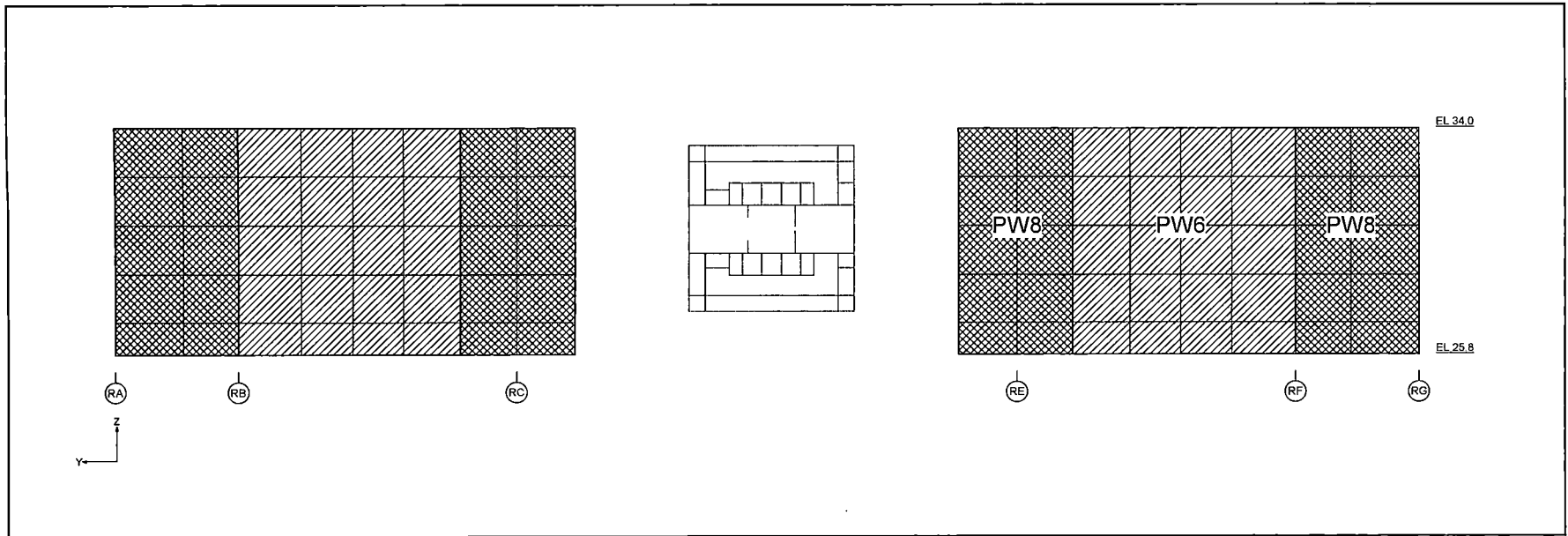


Figure 6.2.3.4-25 Application of Thermal Load on the IC/PCCS Pool Wall-5 (R2)

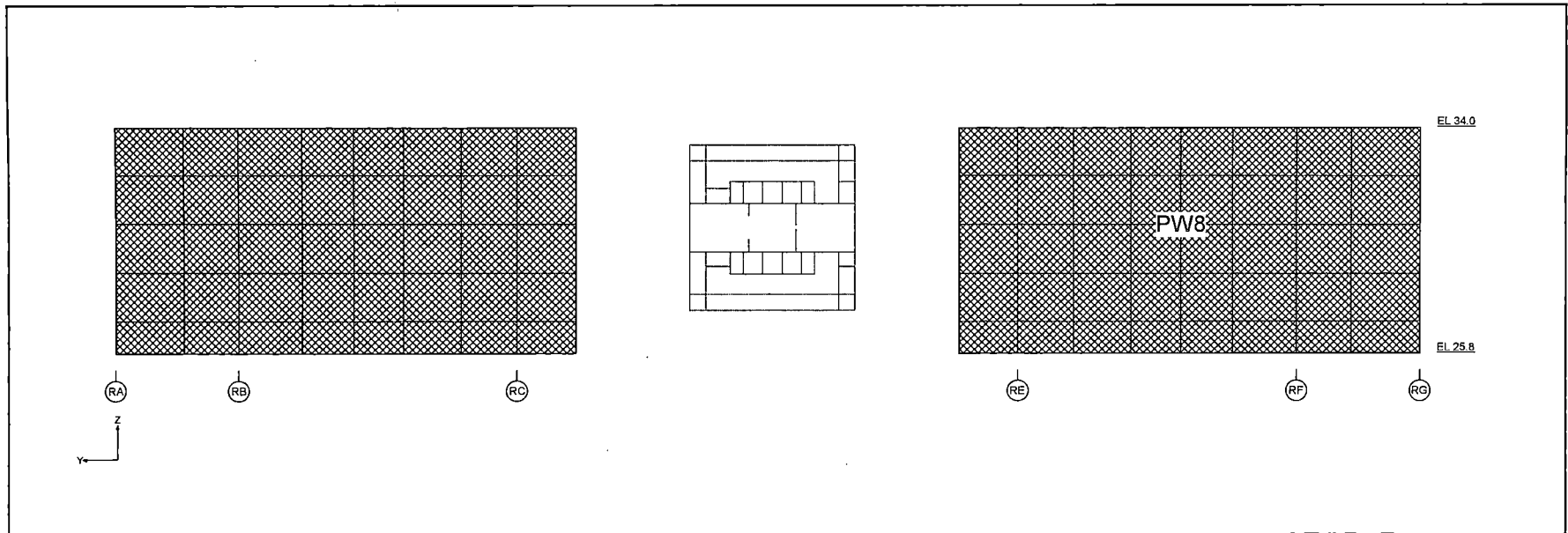


Figure 6.2.3.4-26 Application of Thermal Load on the IC/PCCS Pool Wall-6 (R6)

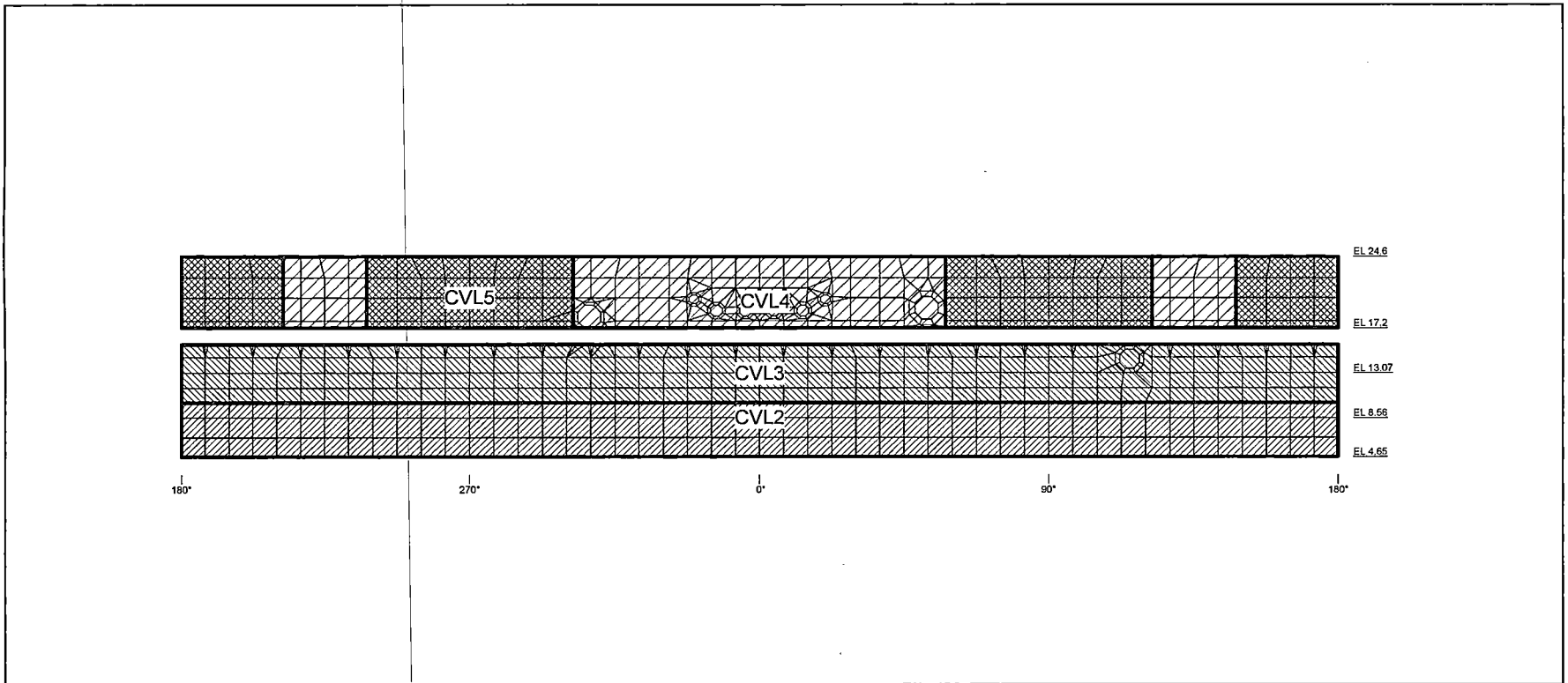


Figure 6.2.3.4-27 Application of Thermal Load on the RCCV Liner (Normal Operation)



HITACHI

WG3-U71-ERD-S-0004 SH NO. 393
REV. 0 of 538

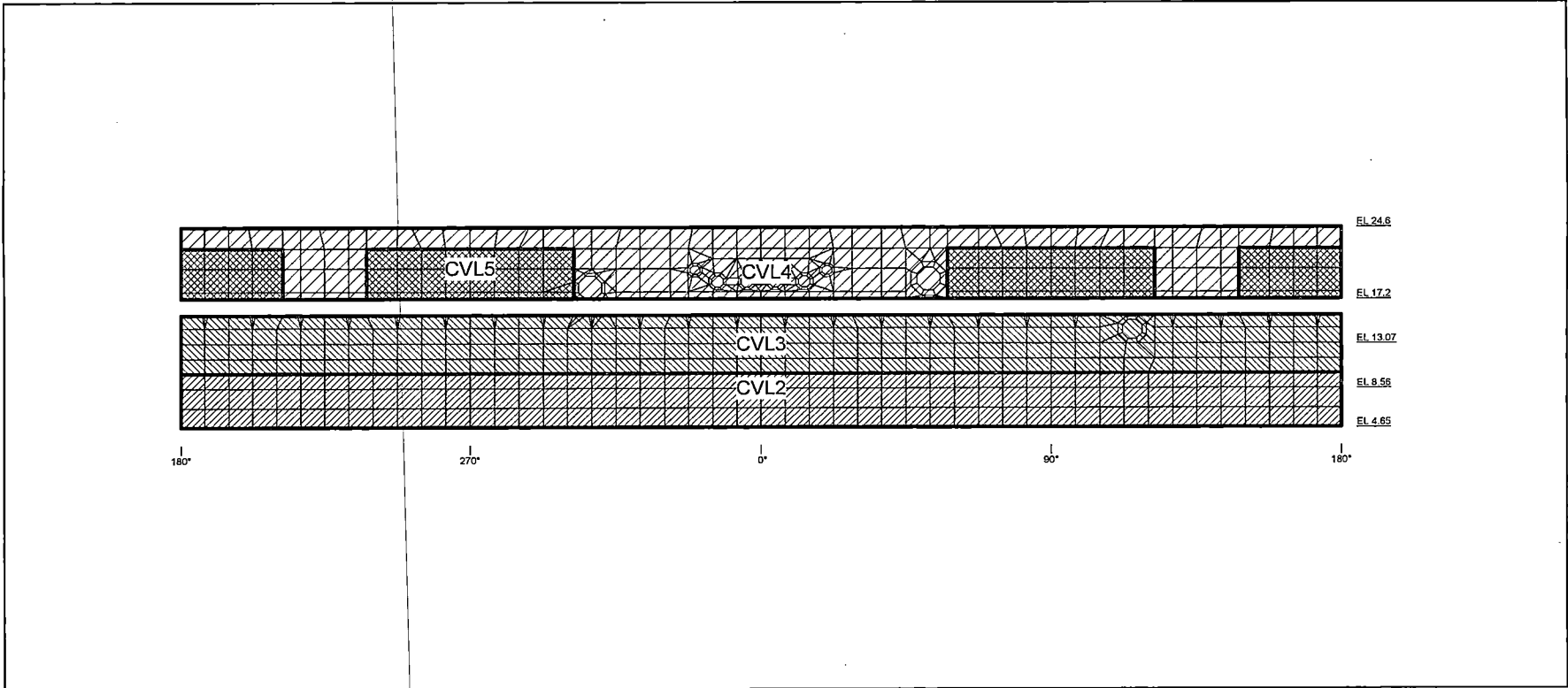


Figure 6.2.3.4-28 Application of Thermal Load on the RCCV Liner (Condition 1)



HITACHI

WG3-U71-ERD-S-0004 SH NO. 394
REV. 0 of 538

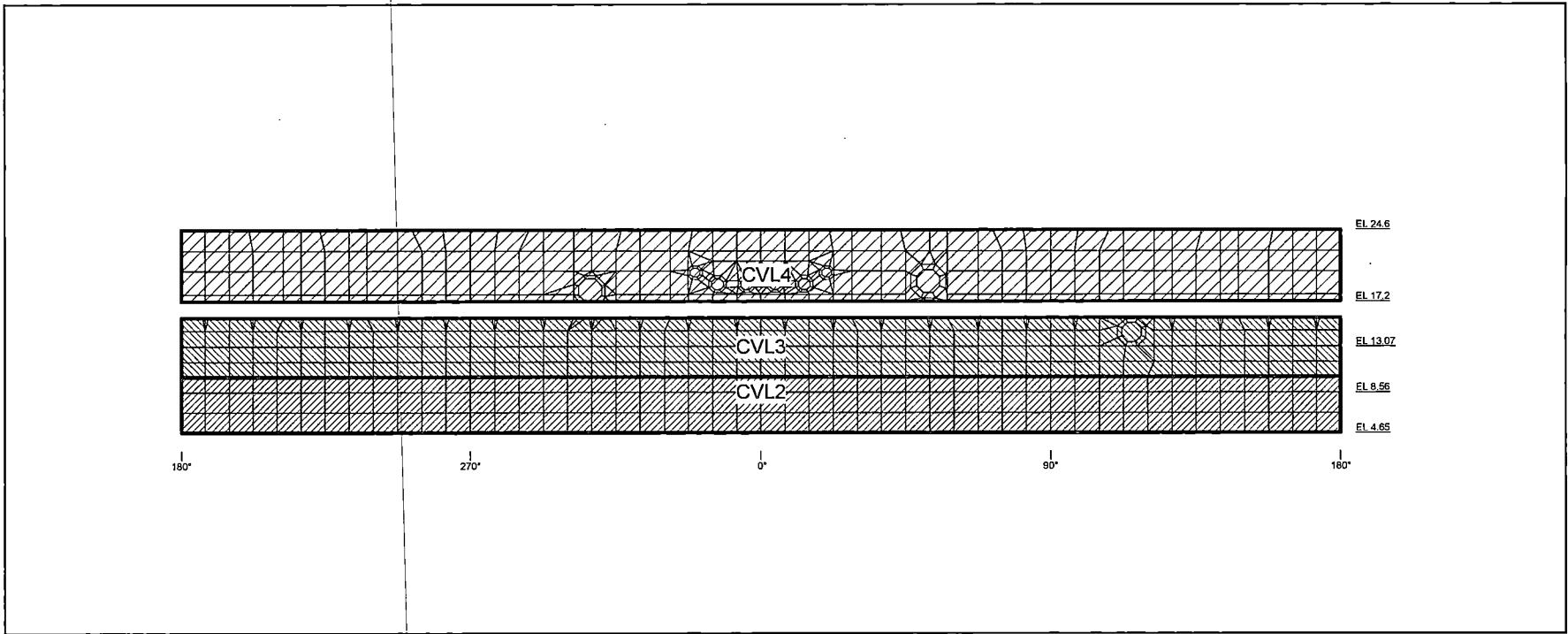


Figure 6.2.3.4-29 Application of Thermal Load on the RCCV Liner (Condition 2)



HITACHI

WG3-U71-ERD-S-0004

SH NO. 395

REV. 0

of 538

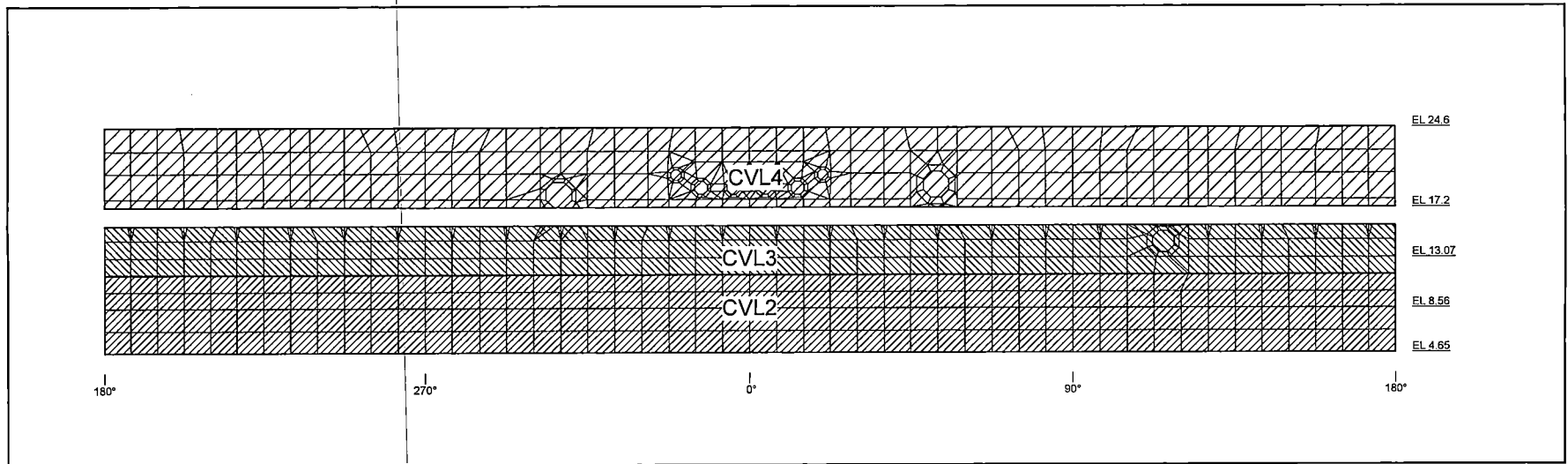


Figure 6.2.3.4-30 Application of Thermal Load on the RCCV Liner (Condition 3)



HITACHI

WG3-U71-ERD-S-0004 SH NO. 396
REV. 0 of 538

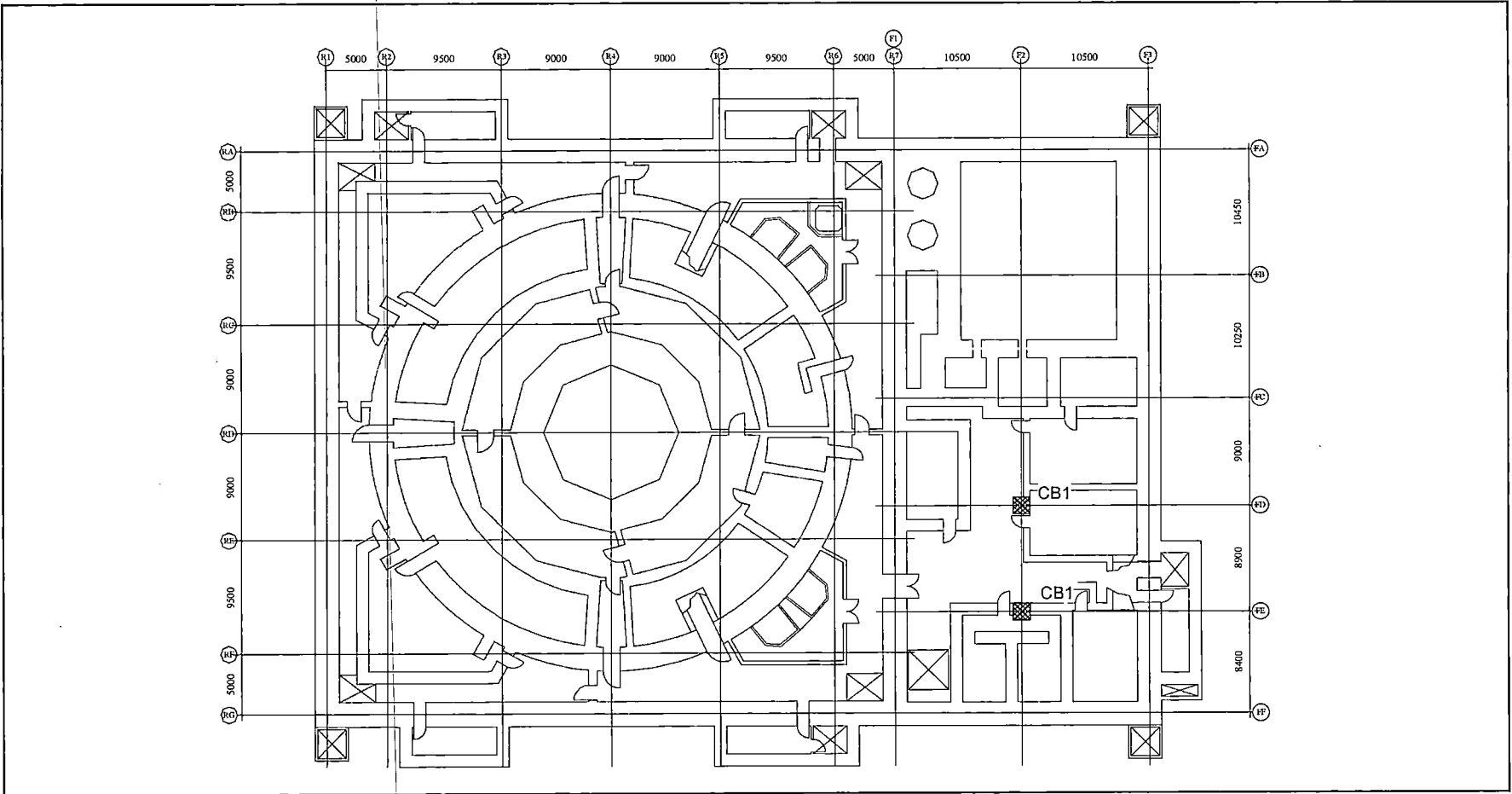


Figure 6.2.3.4-31 Application of Thermal Load on the Reinforced Concrete Girder and Column (EL -11.500)



HITACHI

WG3-U71-ERD-S-0004 SH NO. 397
REV. 0 of 538

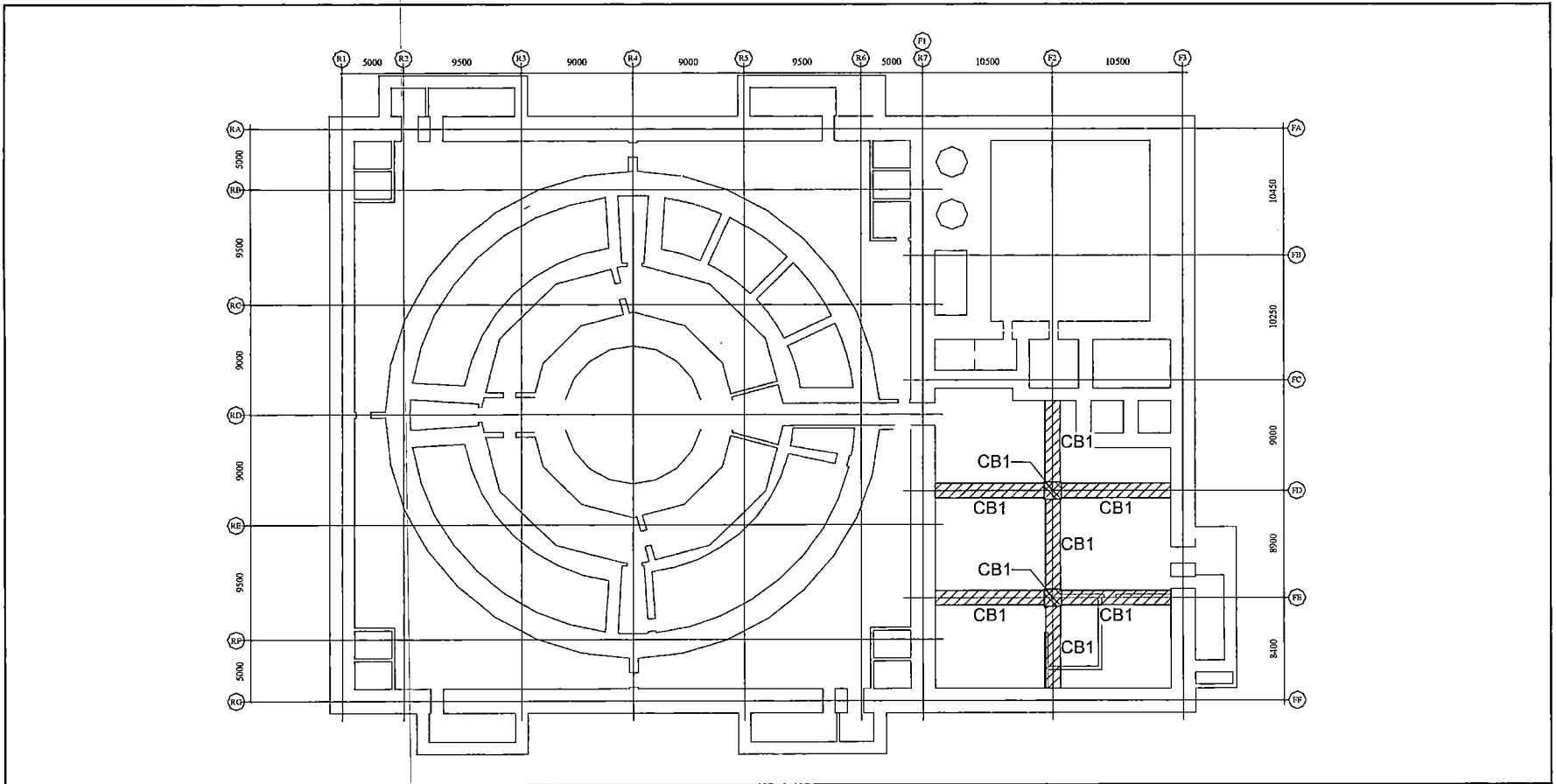


Figure 6.2.3.4-32 Application of Thermal Load on the Reinforced Concrete Girder and Column (EL -6.400)



HITACHI

WG3-U71-ERD-S-0004 SH NO. 398
REV. 0 of 538

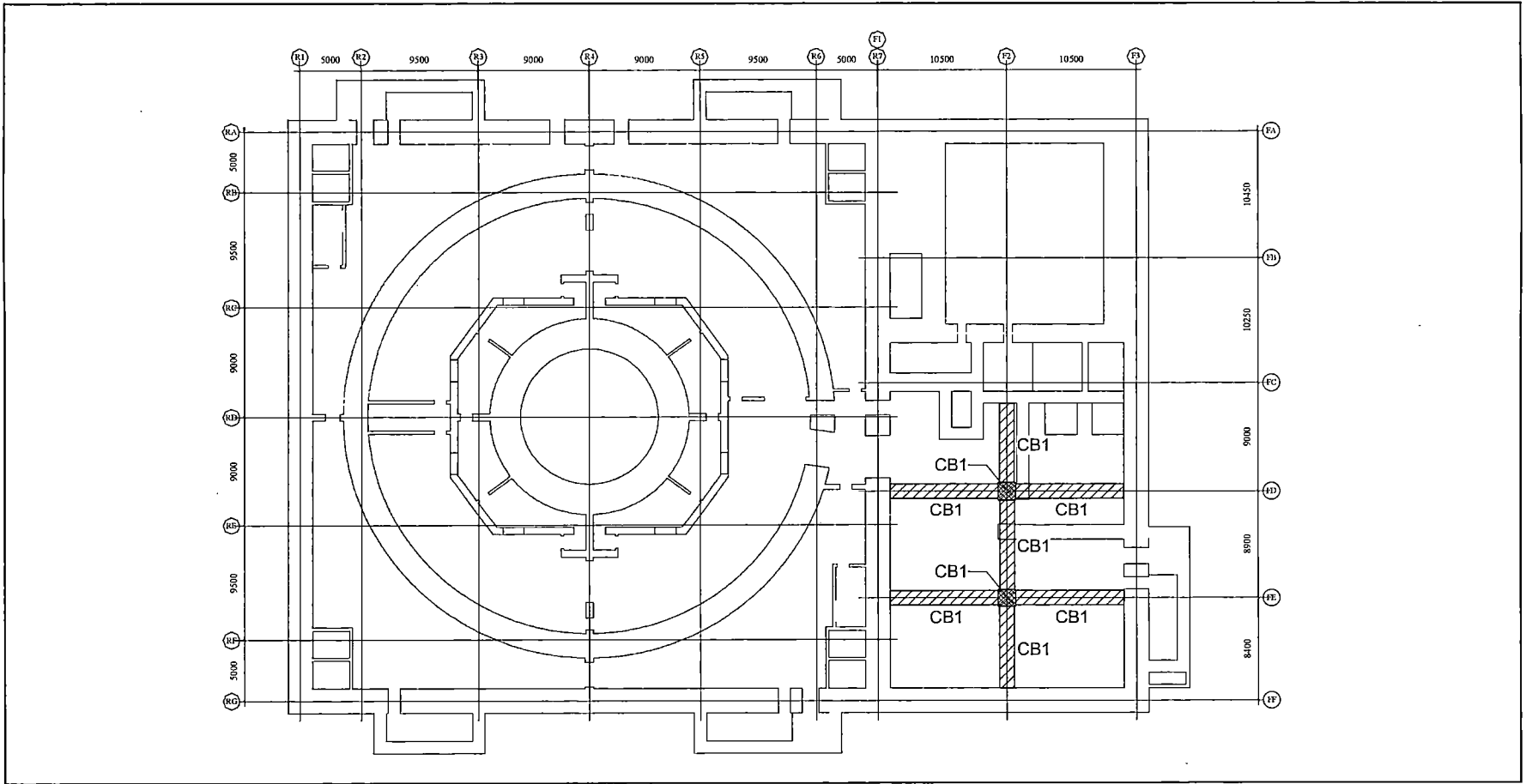


Figure 6.2.3.4-33 Application of Thermal Load on the Reinforced Concrete Girder and Column (EL -1.000)



HITACHI

WG3-U71-ERD-S-0004

SH NO. 399

REV. 0

of 538

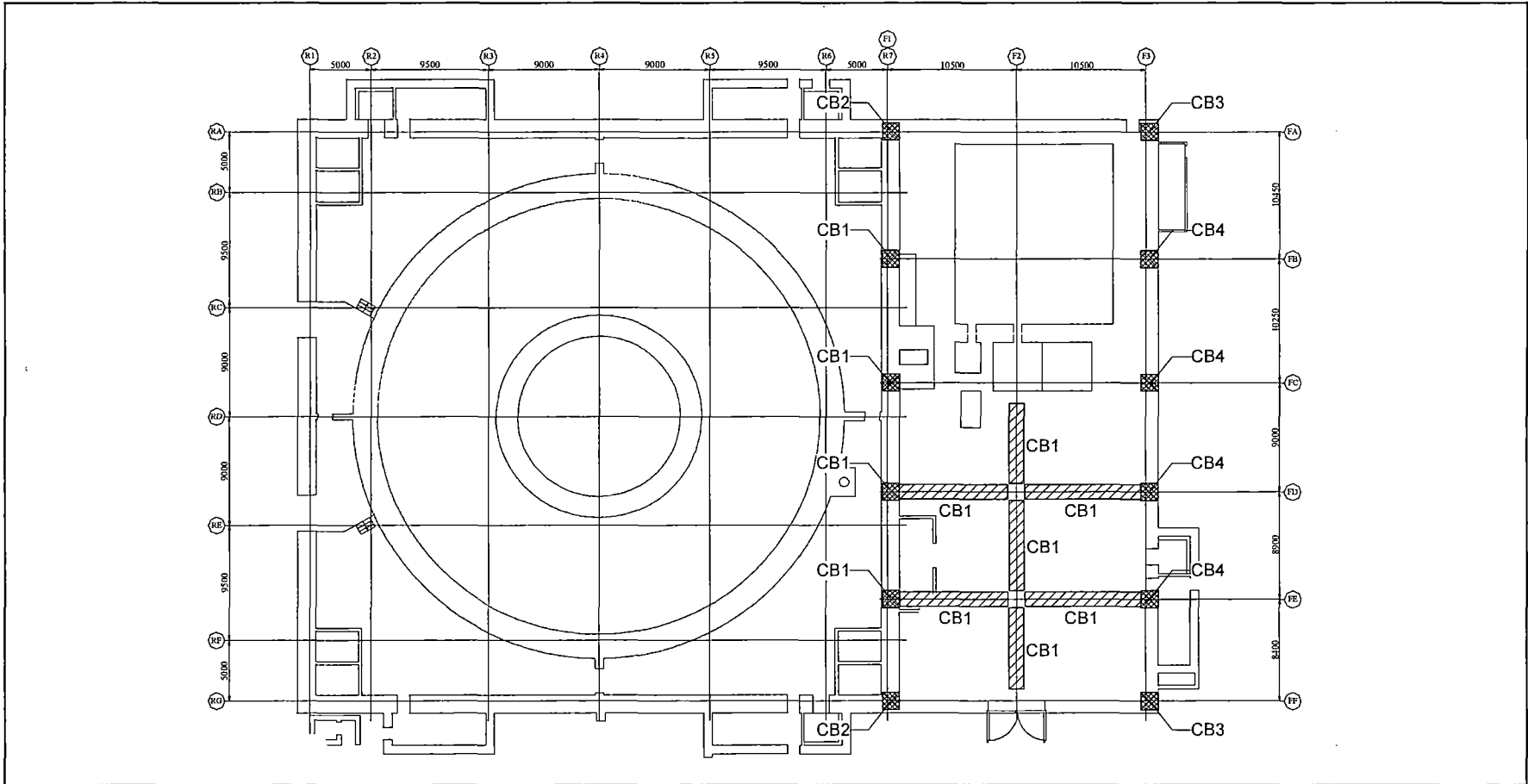


Figure 6.2.3.4-34 Application of Thermal Load on the Reinforced Concrete Girder and Column (EL 4,650)



HITACHI

WG3-U71-ERD-S-0004

SH NO. 400

REV. 0

of 538

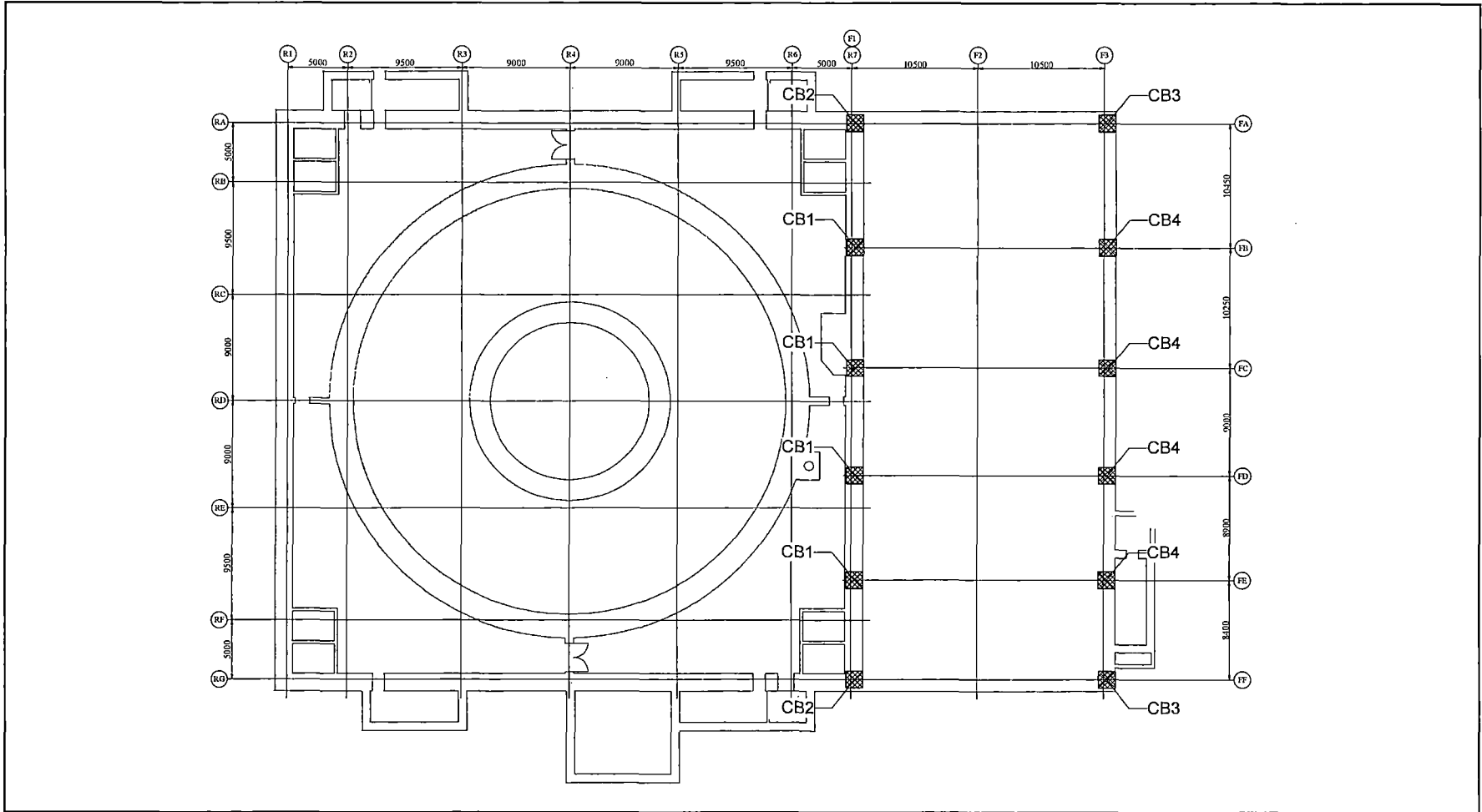


Figure 6.2.3.4-35 Application of Thermal Load on the Reinforced Concrete Girder and Column (EL 9,060)

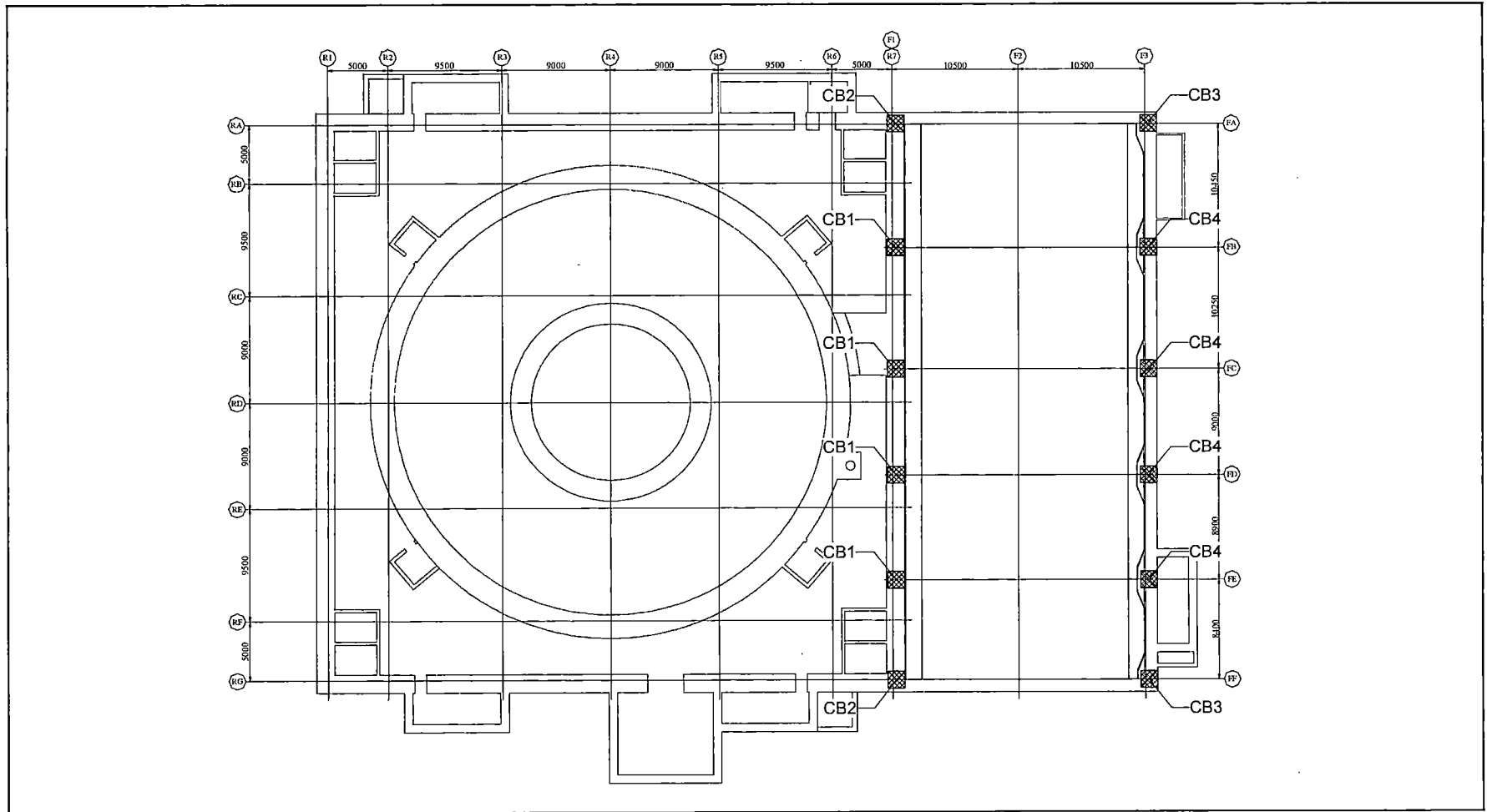


Figure 6.2.3.4-36 Application of Thermal Load on the Reinforced Concrete Girder and Column (EL 13,570)

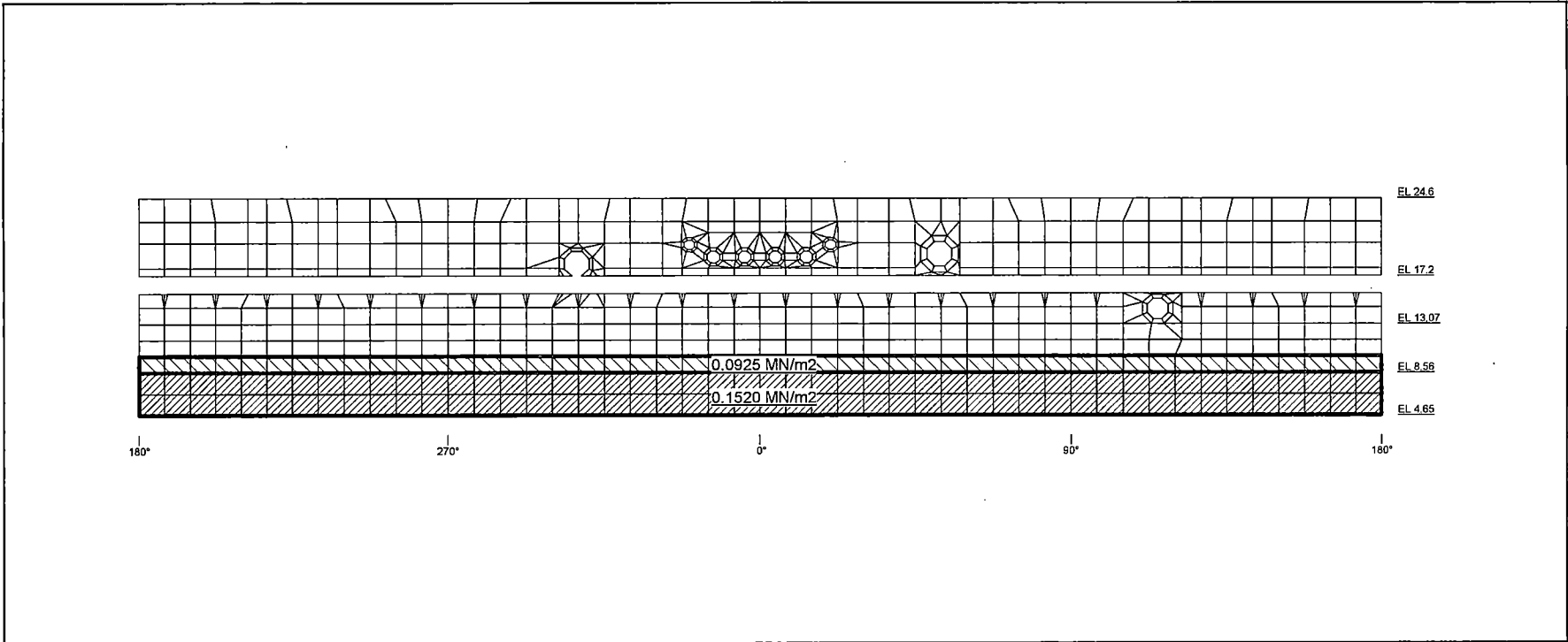


Figure 6.2.3.5-1 Application of Hydrodynamic Load on the RCCV Liner (SRV Positive)

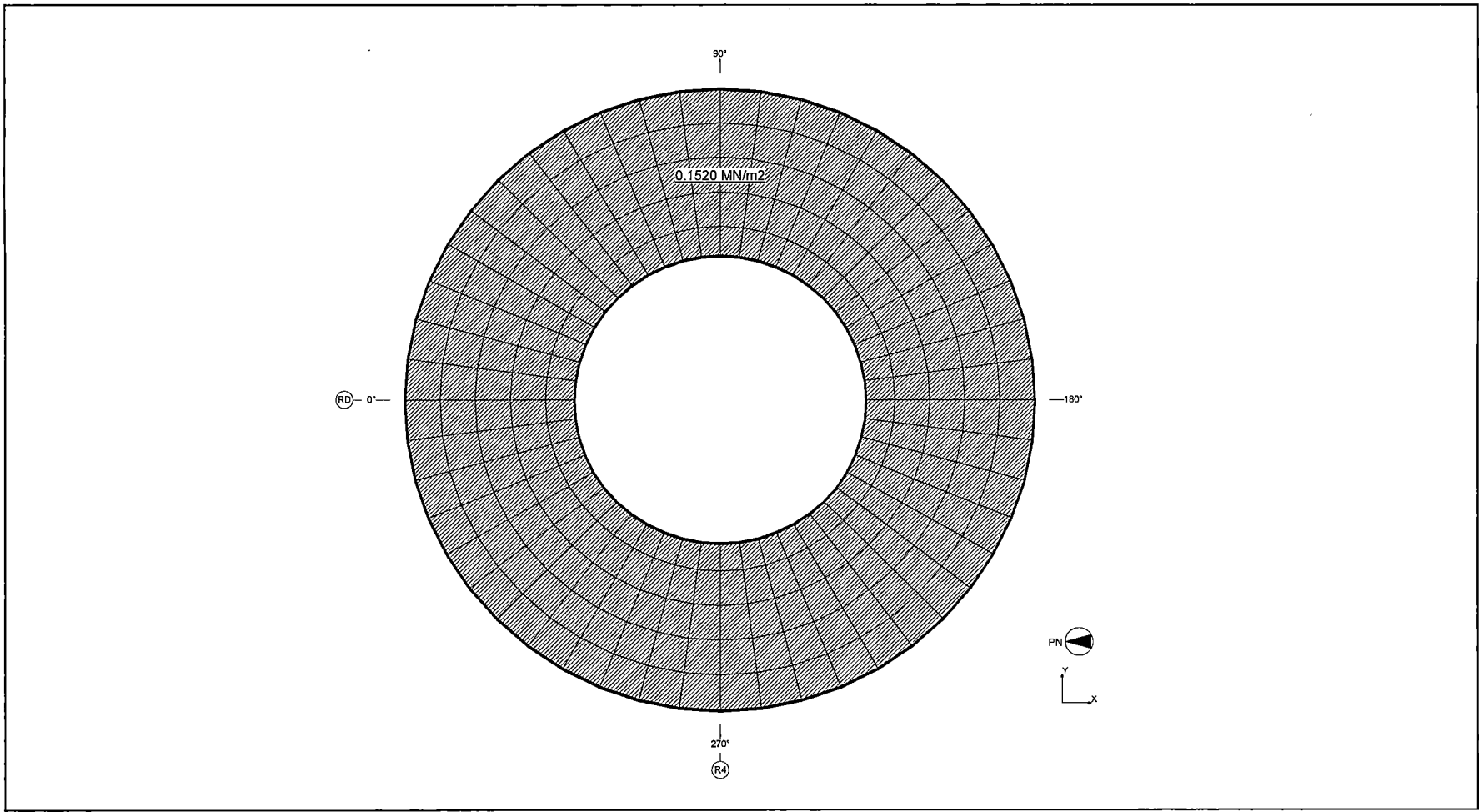


Figure 6.2.3.5-2 Application of Hydrodynamic Load on the Suppression Pool Slab Liner (SRV Positive)

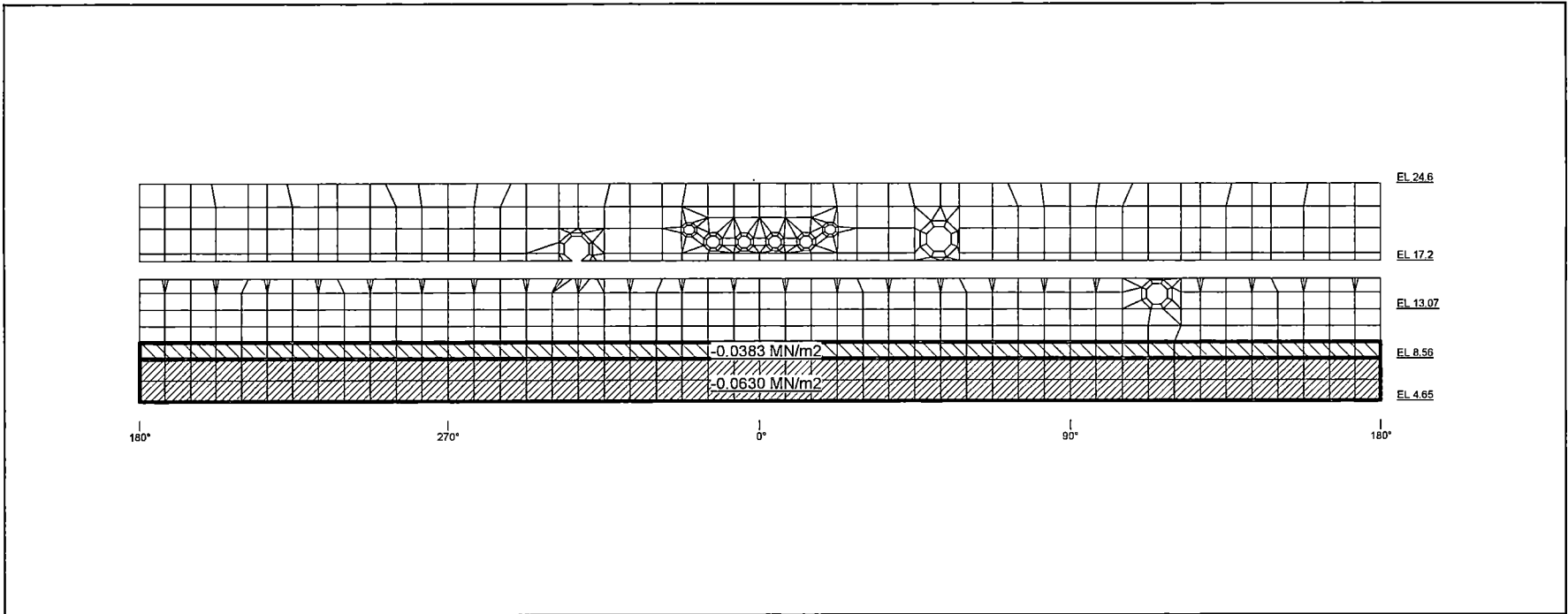


Figure 6.2.3.5-3 Application of Hydrodynamic Load on the RCCV Liner (SRV; Negative)

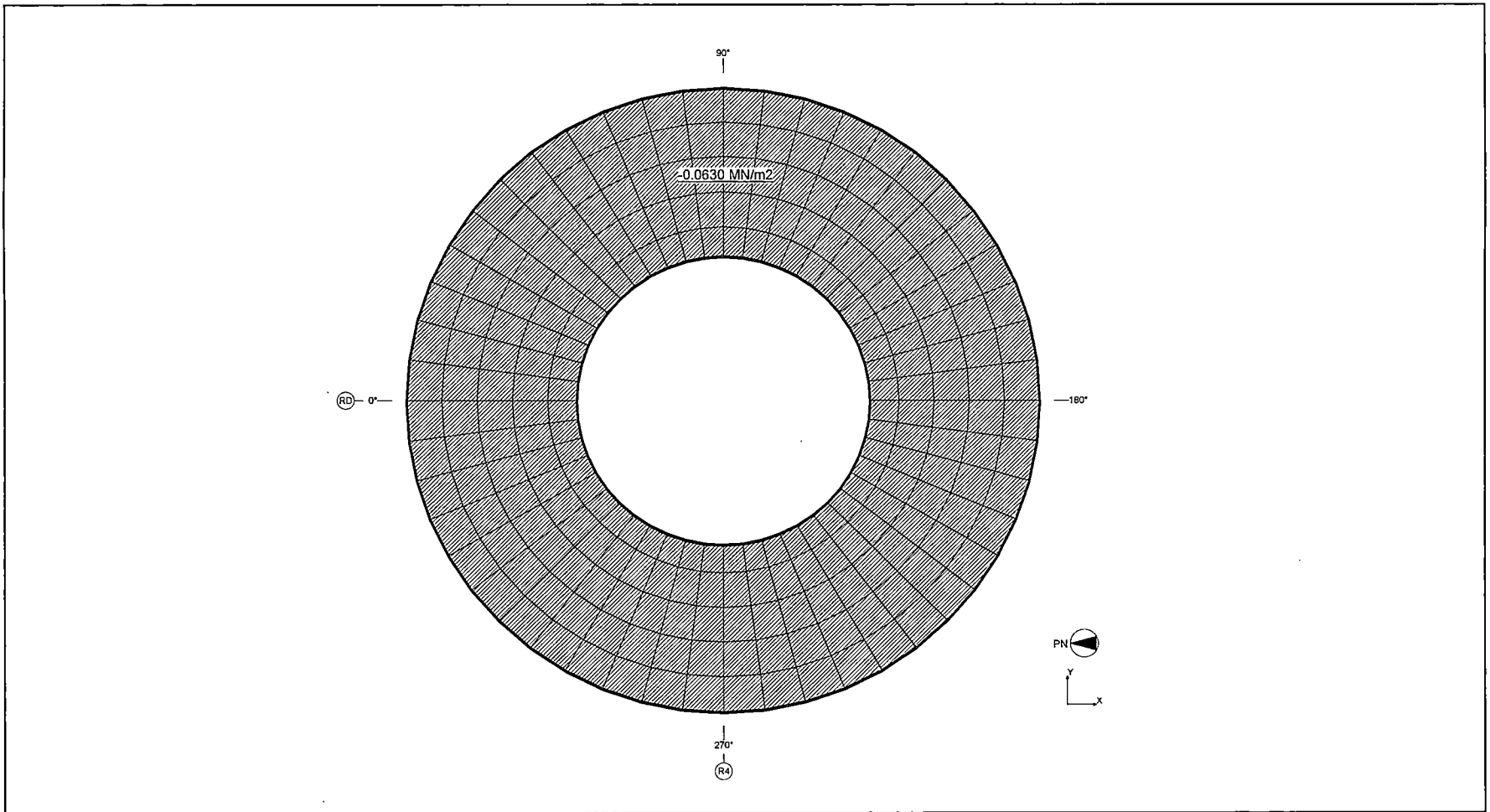


Figure 6.2.3.5-4 Application of Hydrodynamic Load on the Suppression Pool Slab Liner (SRV Negative)



HITACHI

WG3-U71-ERD-S-0004 SH NO. 406
REV. 0 of 538

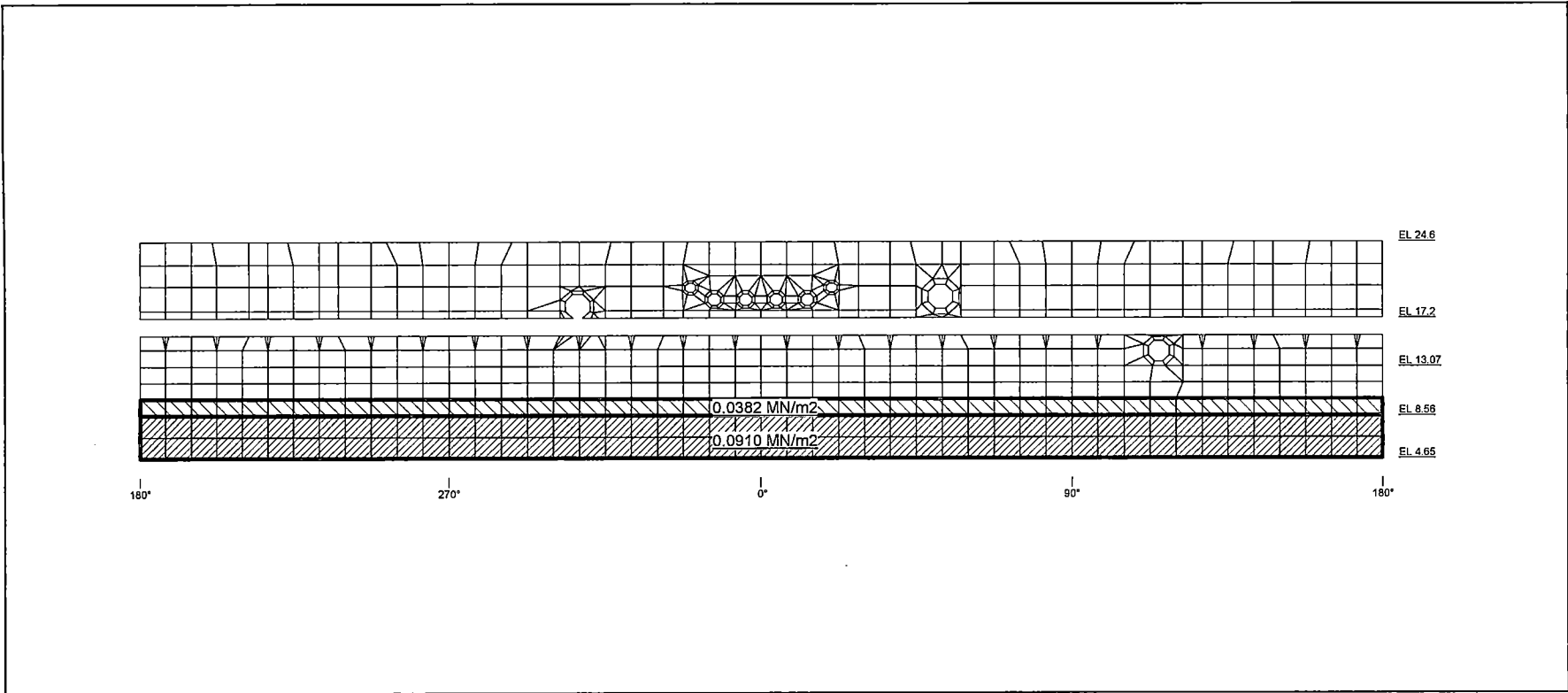


Figure 6.2.3.5-5 Application of Hydrodynamic Load on the RCCV Liner (CH Positive)

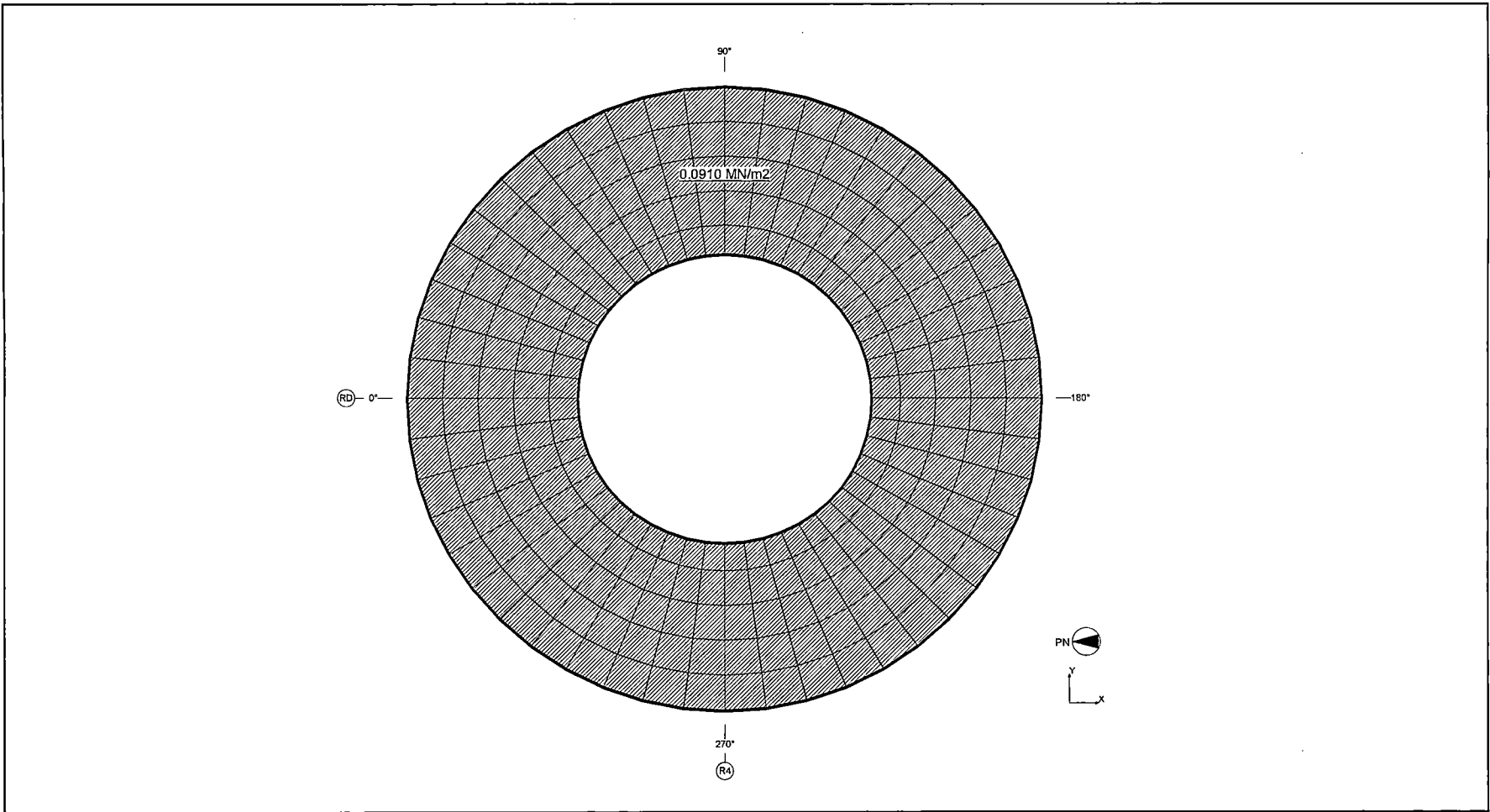


Figure 6.2.3.5-6 Application of Hydrodynamic Load on the Suppression Pool Slab Liner (CH Positive)

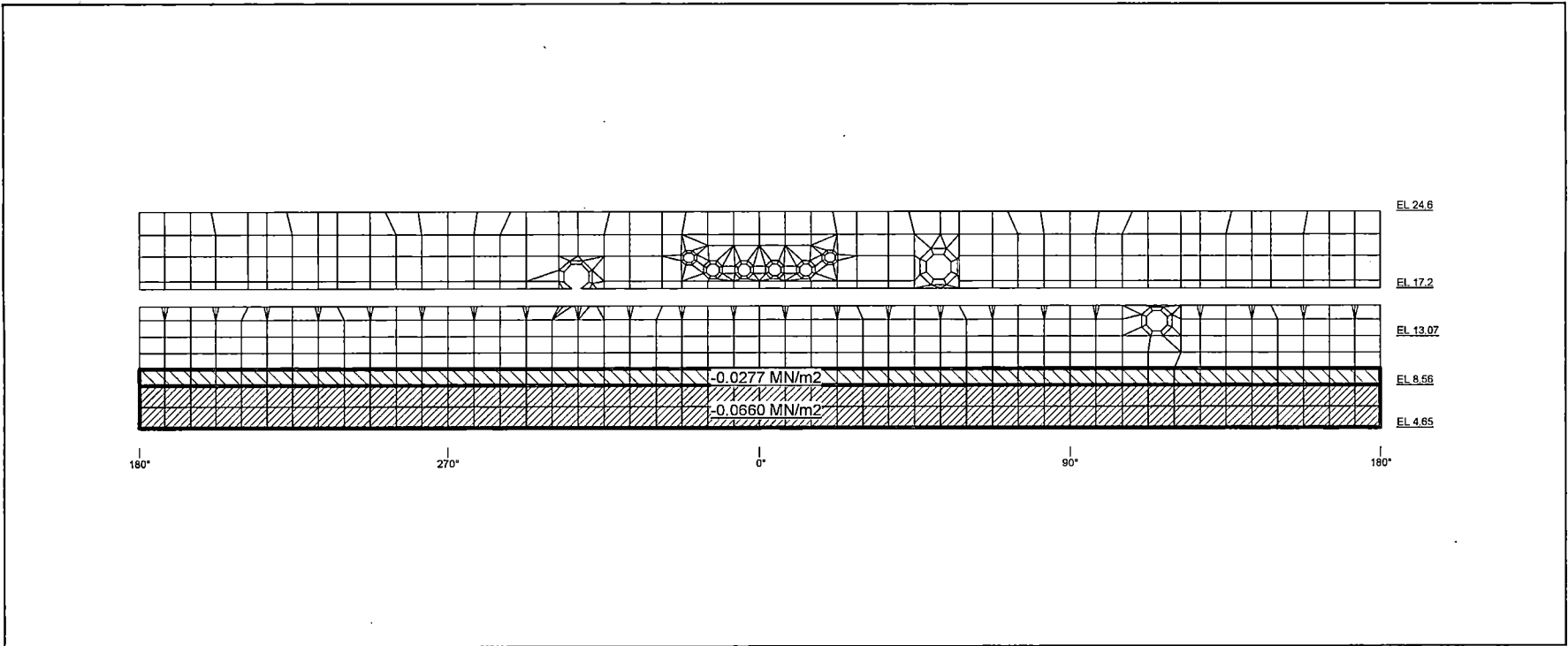


Figure 6.2.3.5-7 Application of Hydrodynamic Load on the RCCV Liner (CH; Negative)

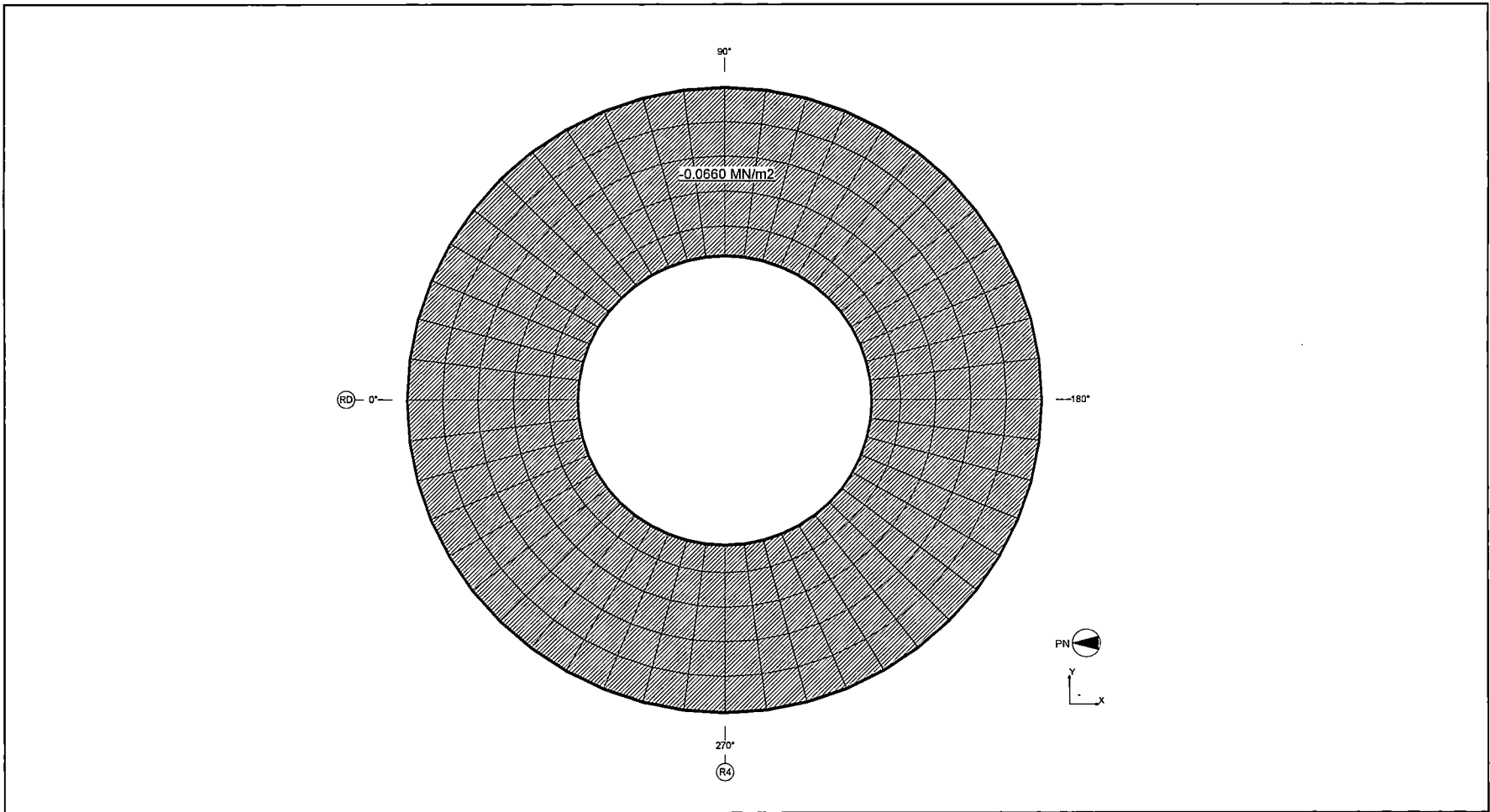


Figure 6.2.3.5-8 Application of Hydrodynamic Load on the Suppression Pool Slab Liner (CH Negative)

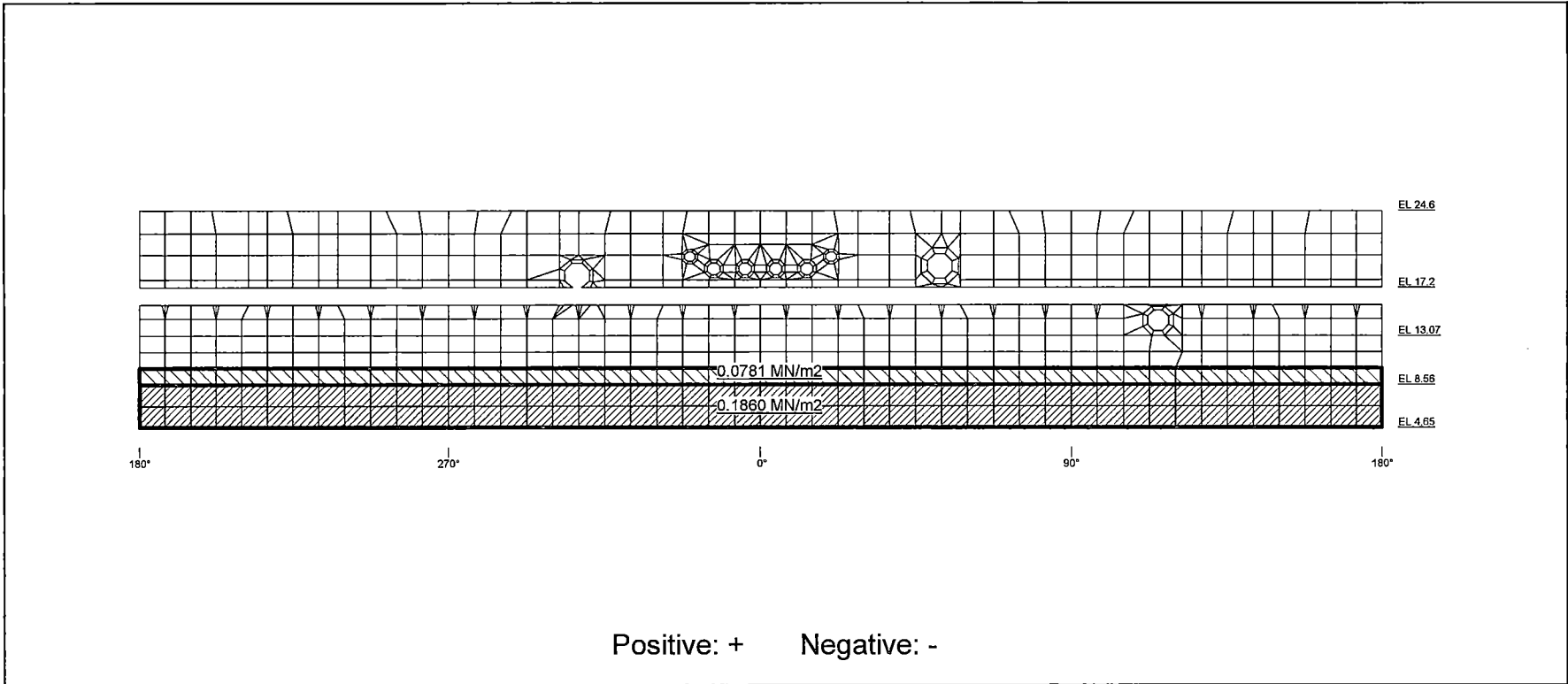


Figure 6.2.3.5-9 Application of Hydrodynamic Load on the RCCV Liner (CO Positive/Negative)

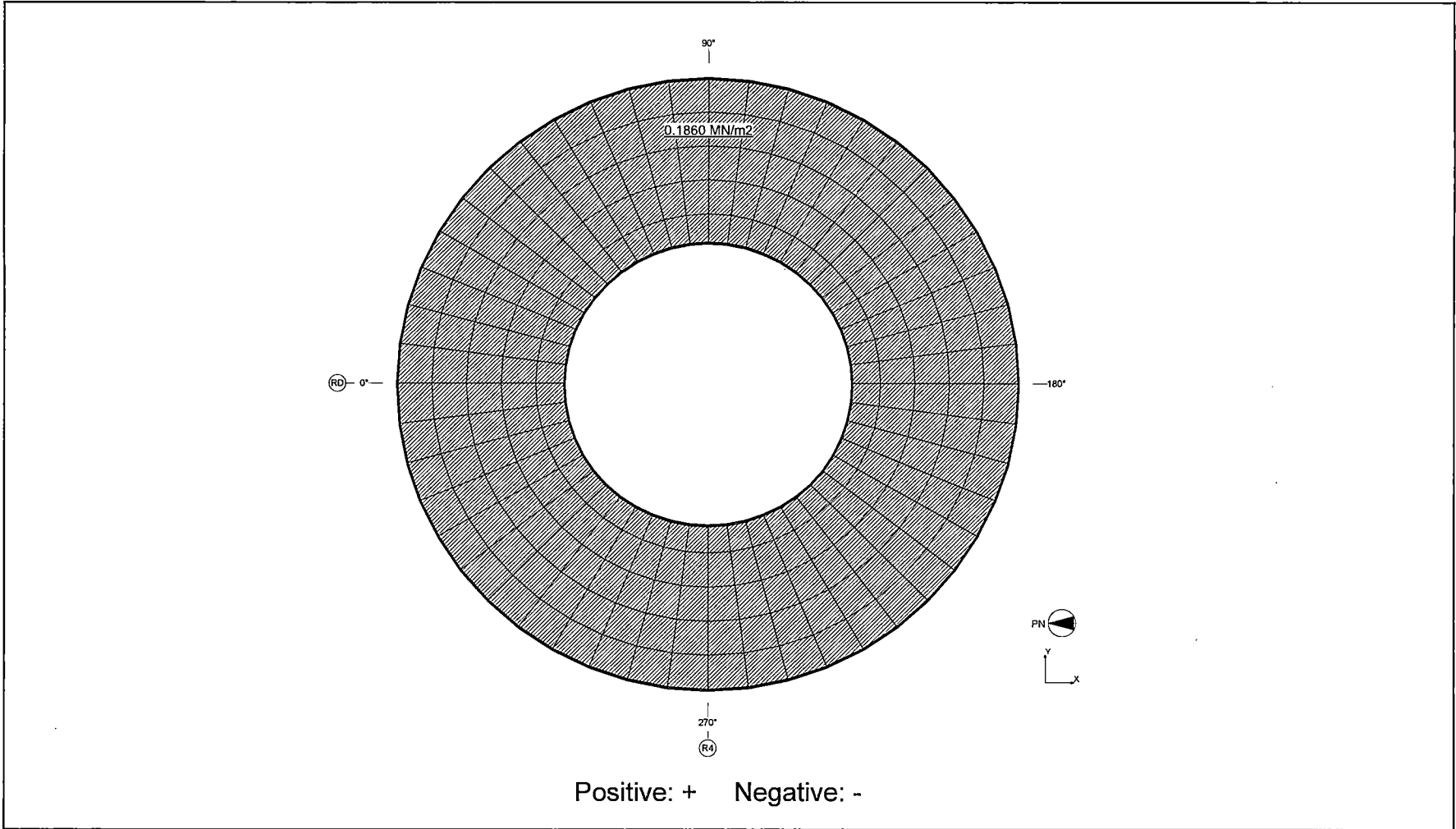


Figure 6.2.3.5-10 Application of Hydrodynamic Load on the Suppression Pool Slab Liner (CO Positive/Negative)



HITACHI

WG3-U71-ERD-S-0004 SH NO. 412
REV. 0 of 538

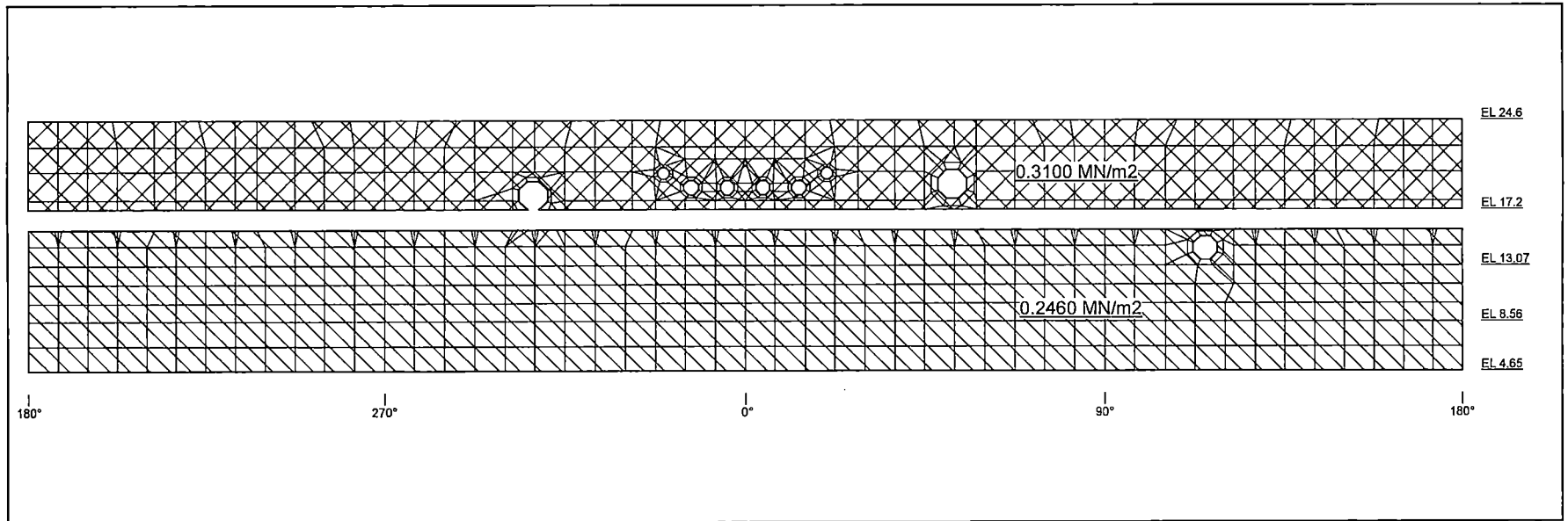


Figure 6.2.3.5-11 Application of Hydrodynamic Load on the RCCV Liner (PS)



HITACHI

WG3-U71-ERD-S-0004

SH NO. 413

REV. 0

of 538

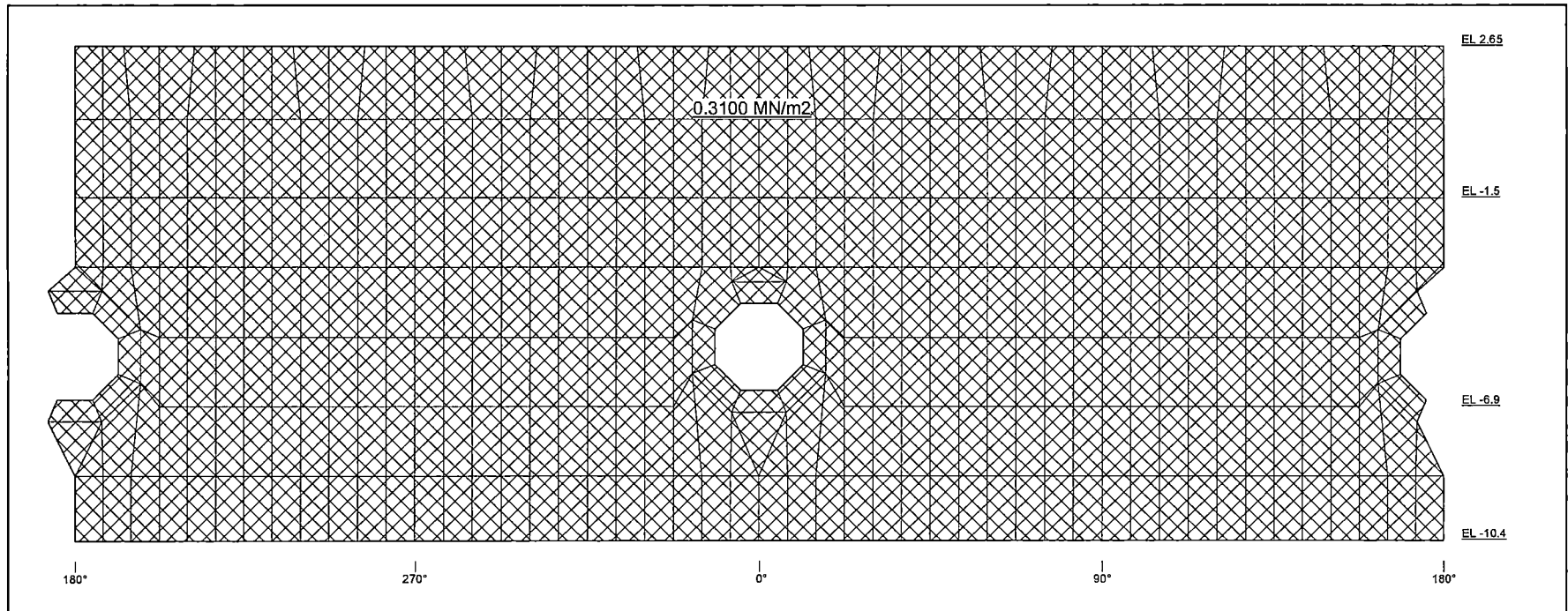


Figure 6.2.3.5-12 Application of Hydrodynamic Load on the RPV Pedestal Liner (PS)



HITACHI

WG3-U71-ERD-S-0004 SH NO. 414
REV. 0 of 538

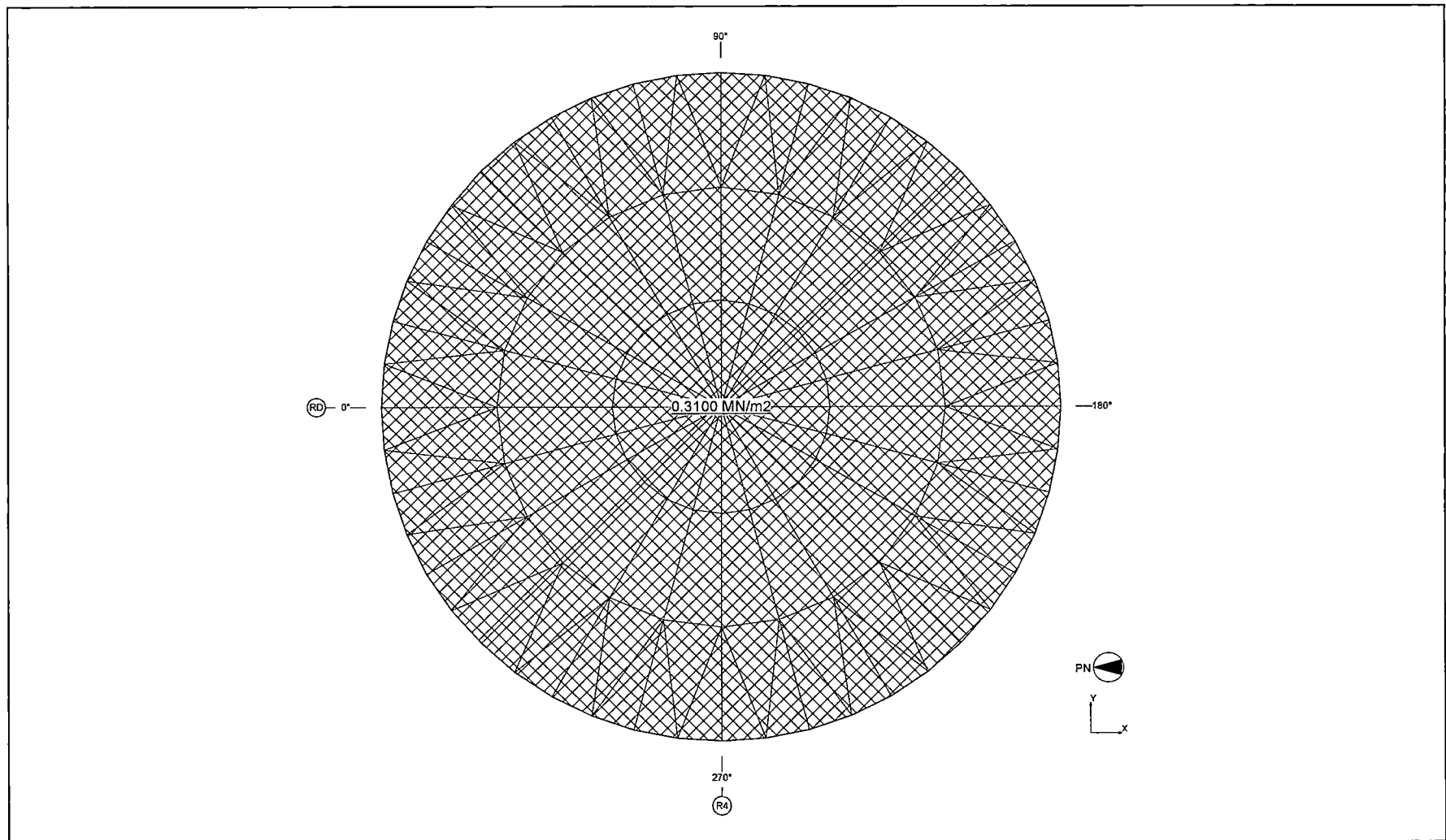


Figure 6.2.3.5-13 Application of Hydrodynamic Load on the Basemat Liner (PS)

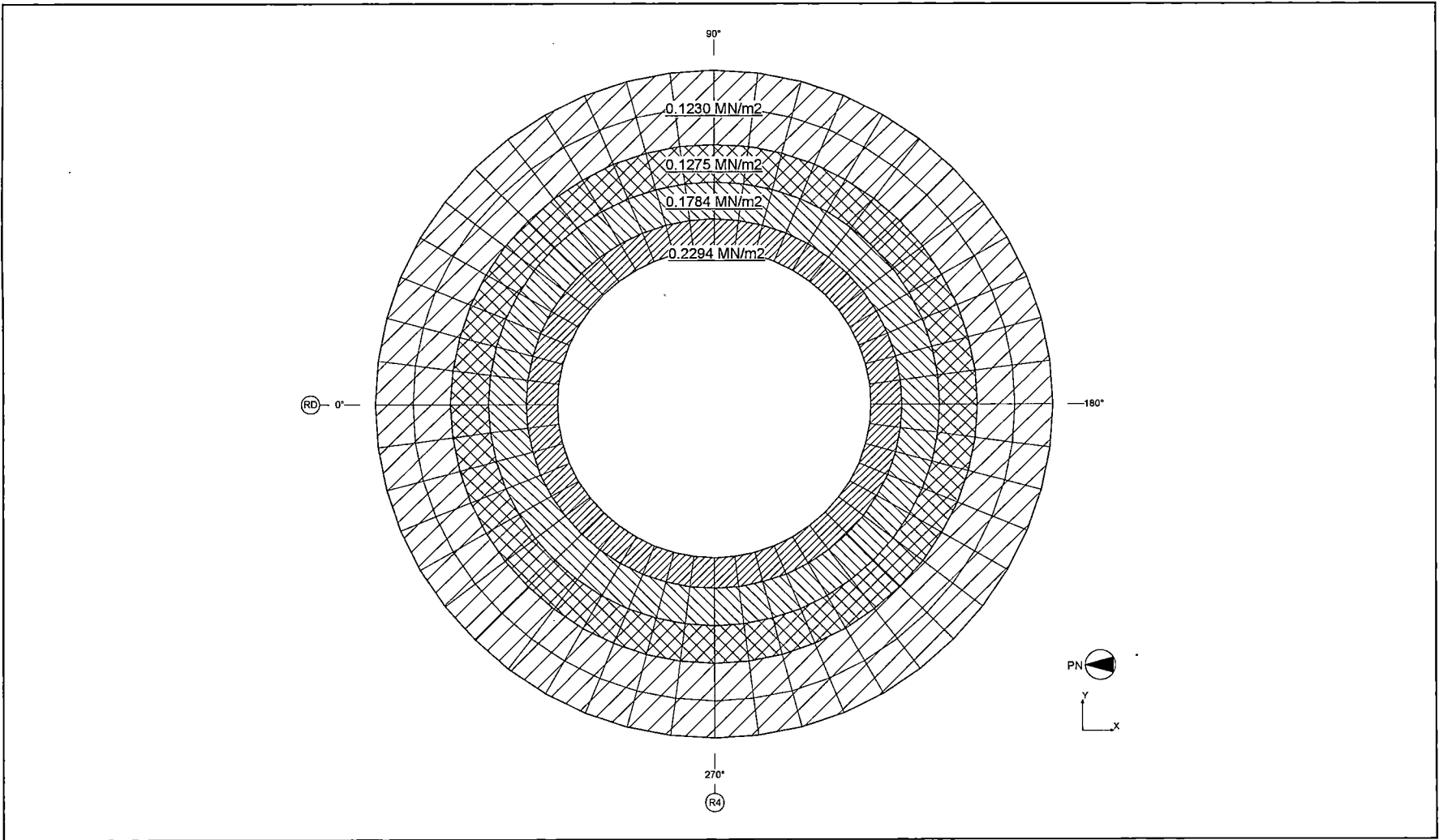


Figure 6.2.3.5-14 Application of Hydrodynamic Load on the Suppression Pool Slab Liner (PS)

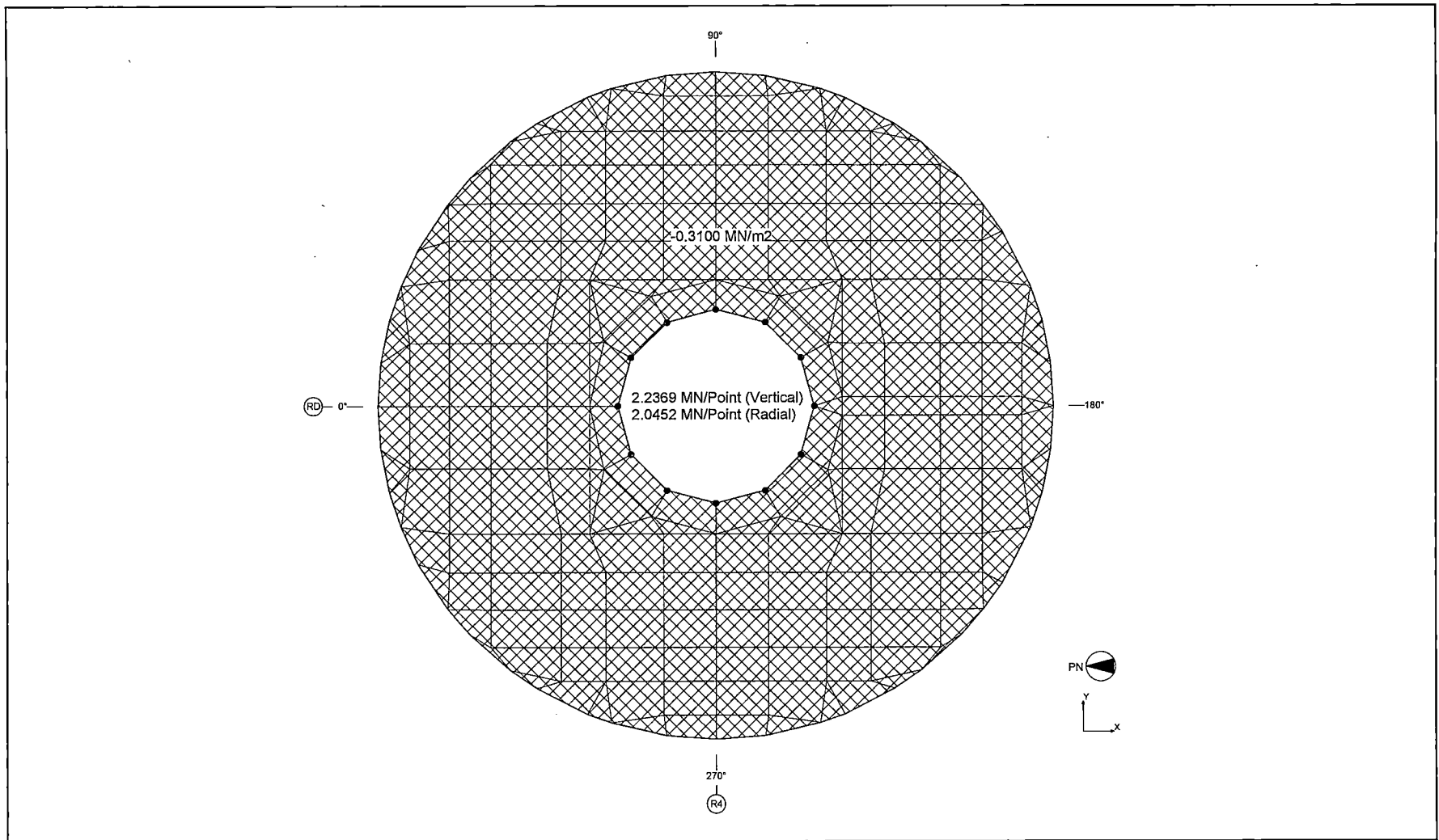


Figure 6.2.3.5-15 Application of Hydrodynamic Load on the Top Slab Liner (PS)



HITACHI

WG3-U71-ERD-S-0004

SH NO. 417

REV. 0

of 538

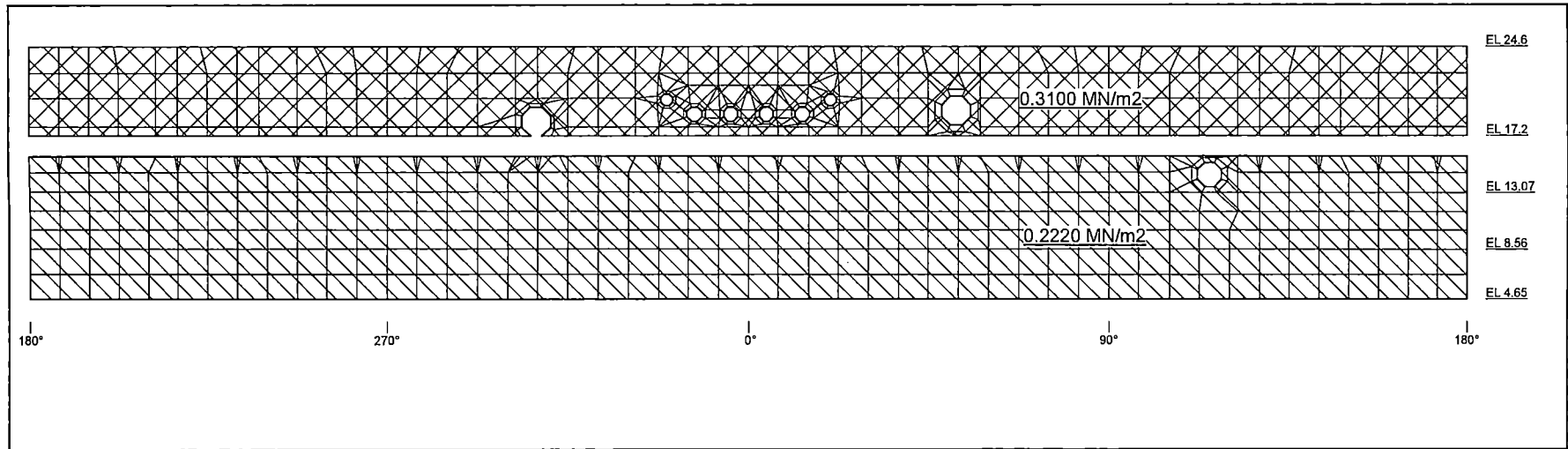


Figure 6.2.3.5-16 Application of Hydrodynamic Load on the RCCV Liner (PS: Pressure Concurrent with Froth Impact Loads)



HITACHI

WG3-U71-ERD-S-0004 SH NO. 418
REV. 0 of 538

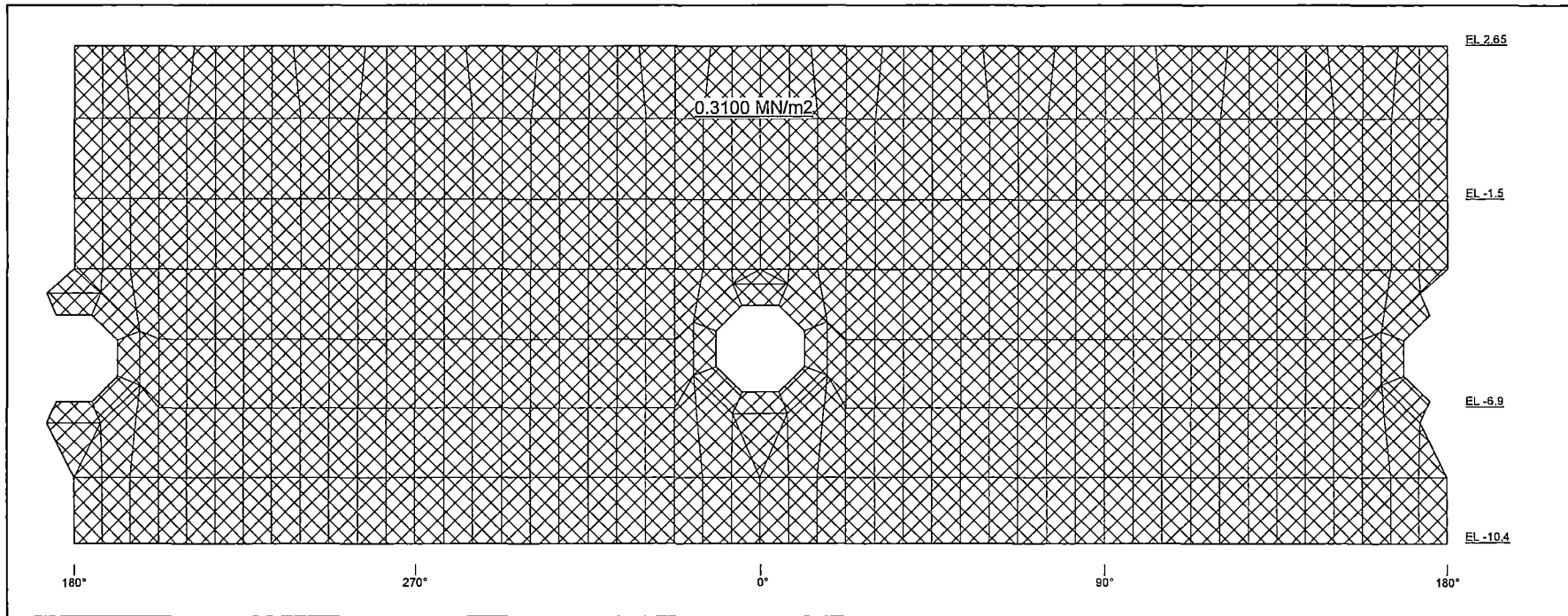


Figure 6.2.3.5-17 Application of Hydrodynamic Load on the RPV Pedestal Liner (PS:Pressure Concurrent with Froth Impact Loads)



HITACHI

WG3-U71-ERD-S-0004 SH NO. 419
REV. 0 of 538

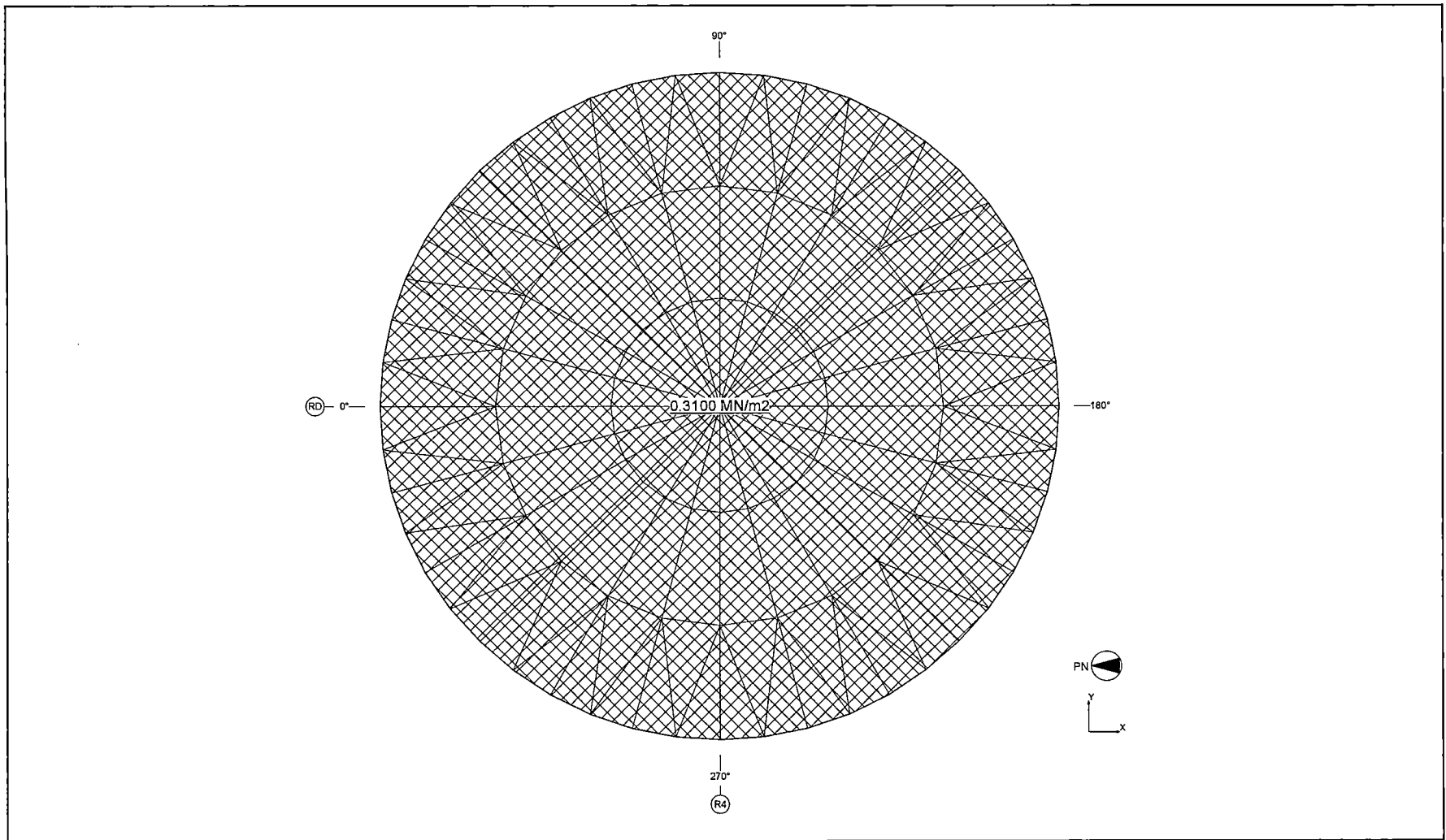


Figure 6.2.3.5-18 Application of Hydrodynamic Load on the Basemat Liner (PS:Pressure Concurrent with Froth Impact Loads)



HITACHI

WG3-U71-ERD-S-0004 SH NO. 420
REV. 0 of 538

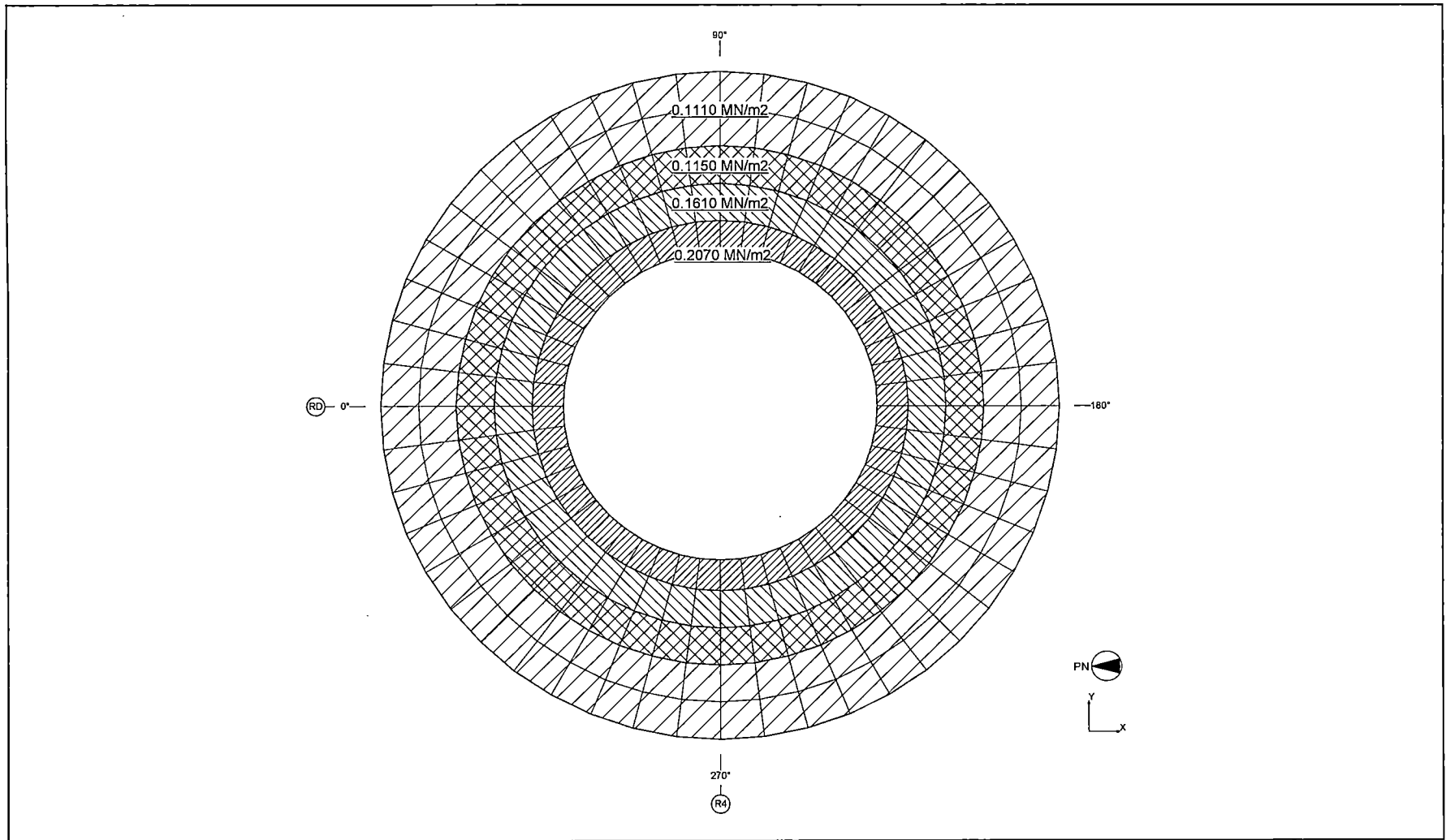


Figure 6.2.3.5-19 Application of Hydrodynamic Load on the Suppression Pool Slab Liner (PS:Pressure Concurrent with Froth Impact Loads)

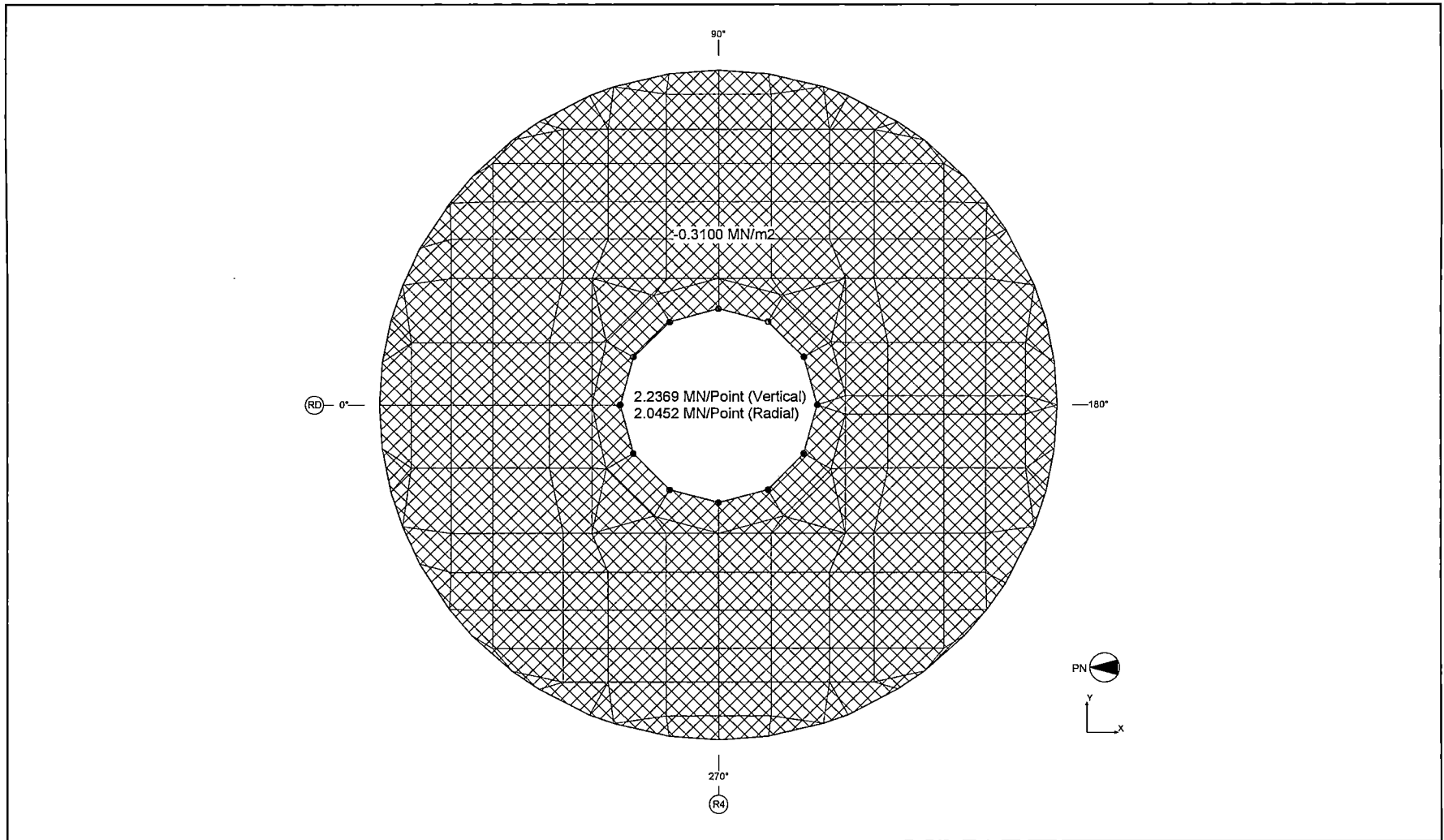
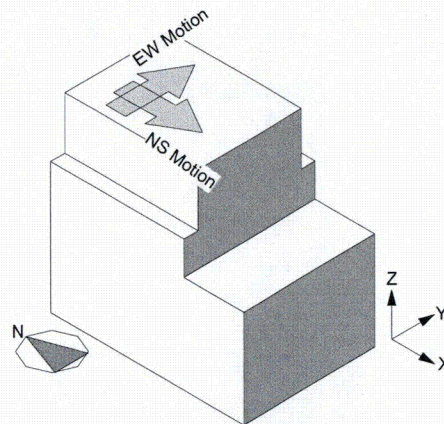
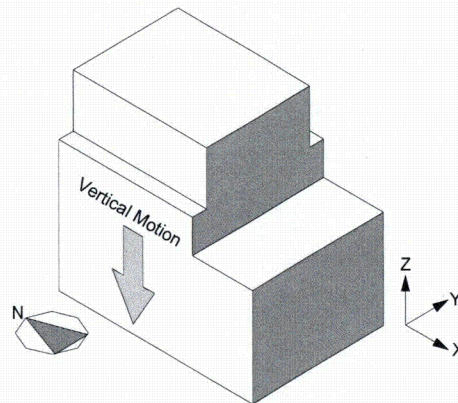


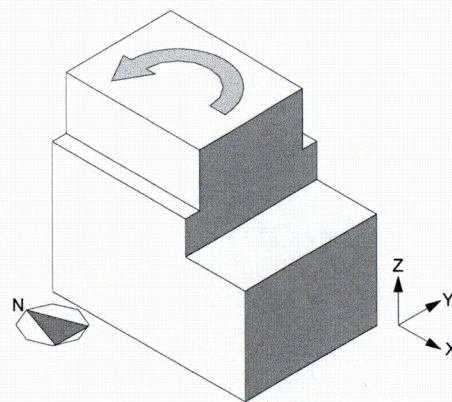
Figure 6.2.3.5-20 Application of Hydrodynamic Load on the Top Slab Liner (PS:Pressure Concurrent with Froth Impact Loads)



Horizontal Seismic Load



Vertical Seismic Load



Torsional Seismic Load

Figure 6.2.3.9-1 Seismic Load Directions in the Stress Analysis

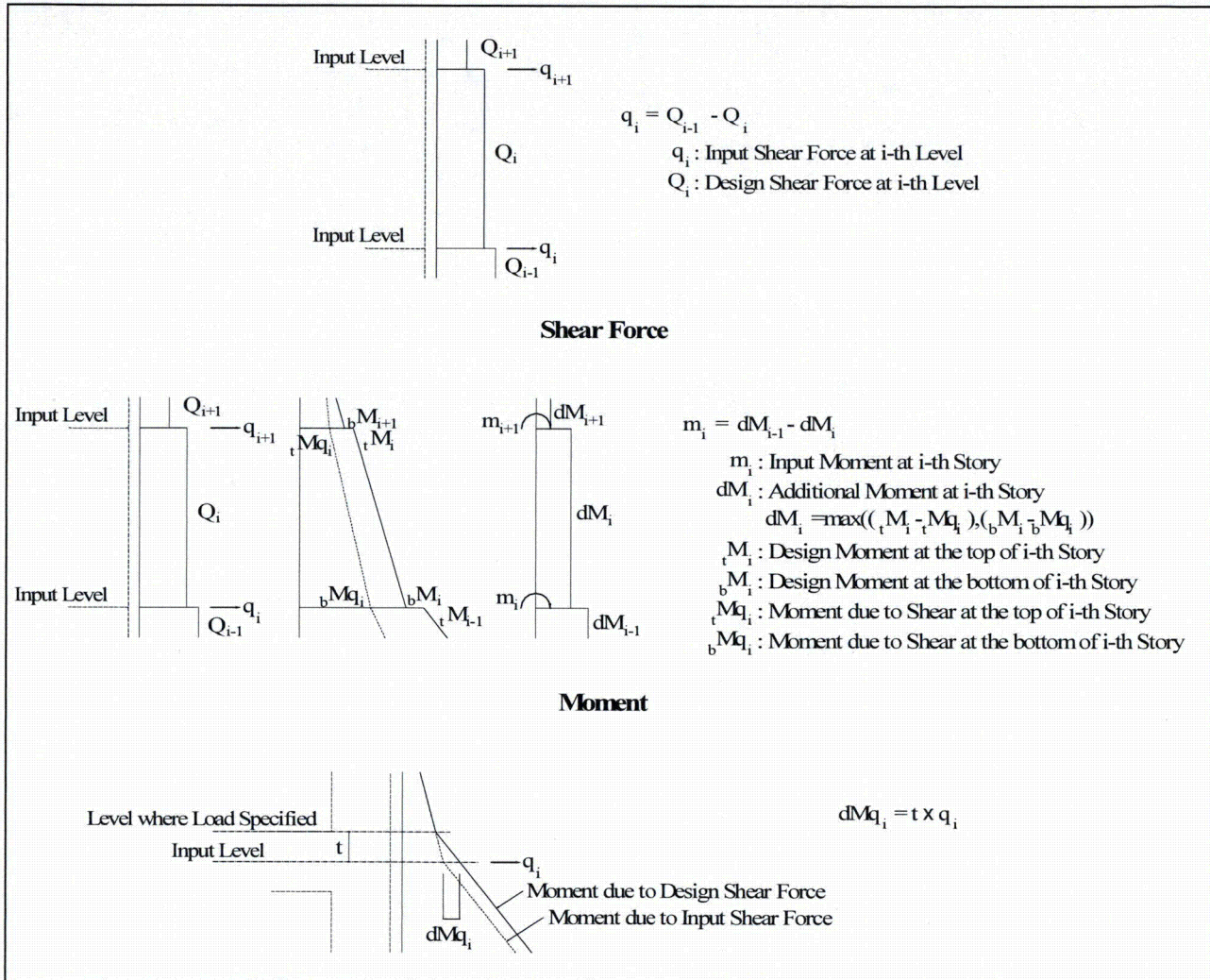


Figure 6.2.3.9-2 Calculation of Applied Shear Forces and Moments

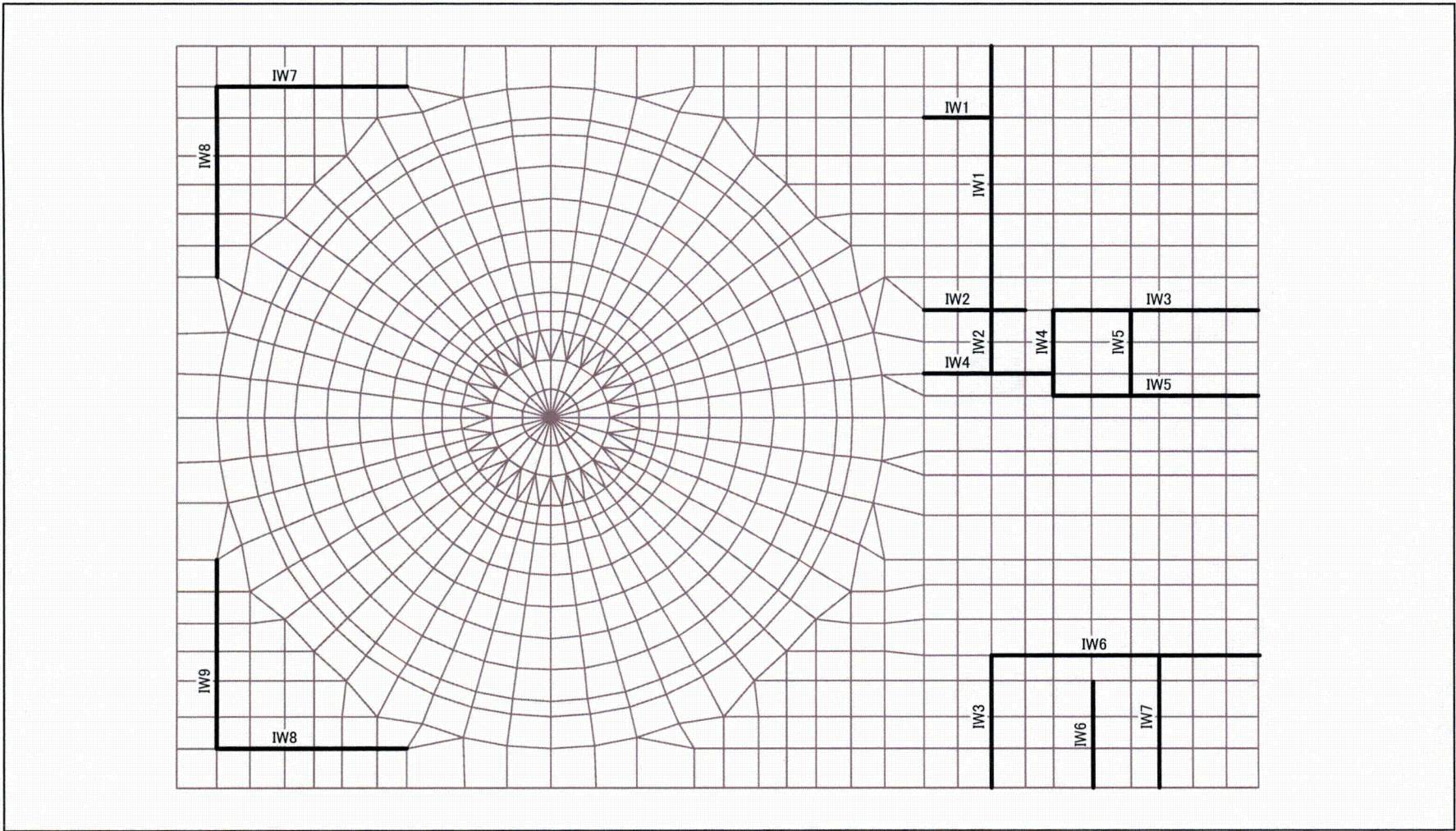


Figure 6.2.3.9-3 Inner Walls Where Shear Force Are Applied - EL -11,500~EL-6,400

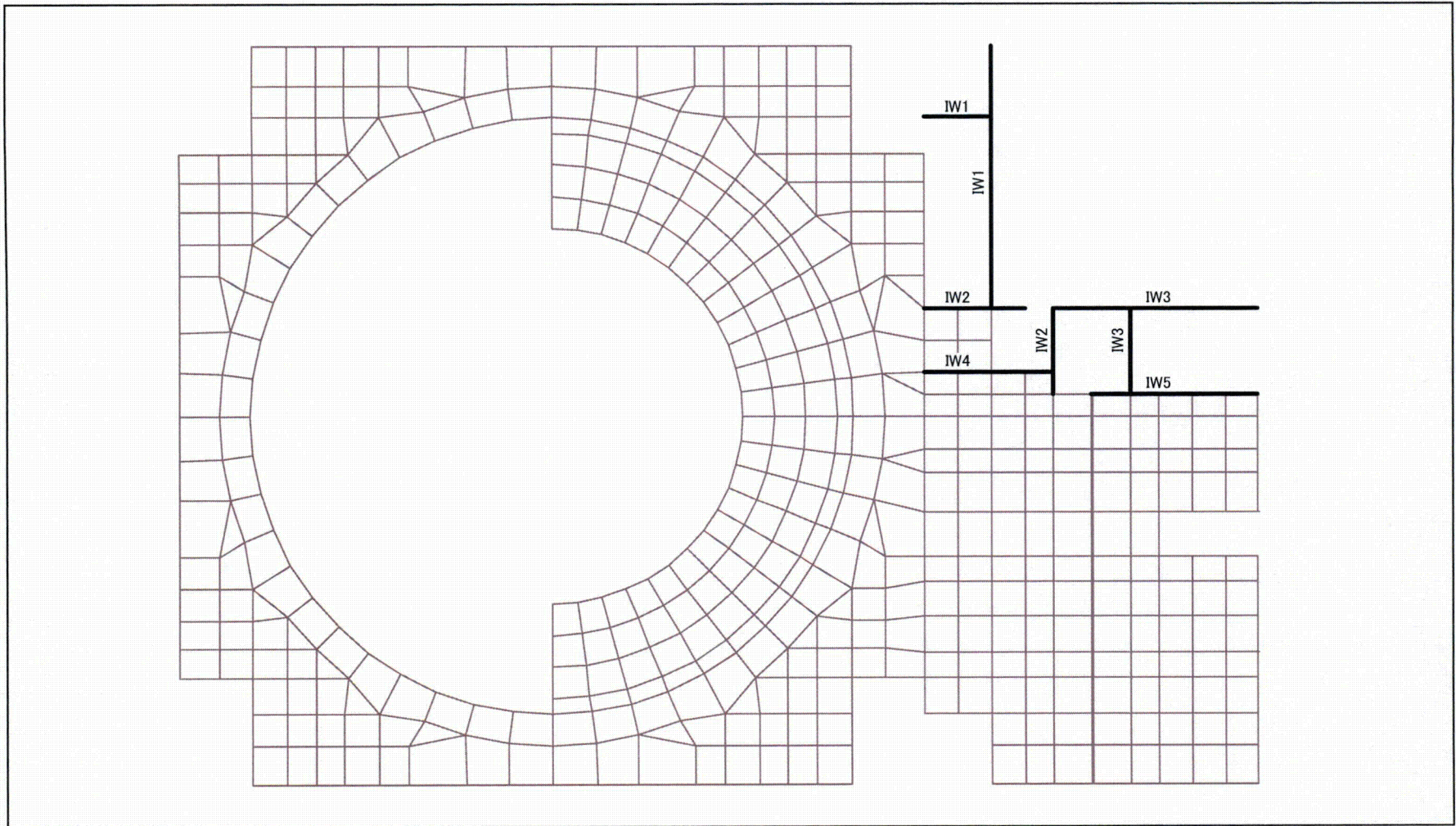


Figure 6.2.3.9-4 Inner Walls Where Shear Force Are Applied - EL-6,400~EL-1,000

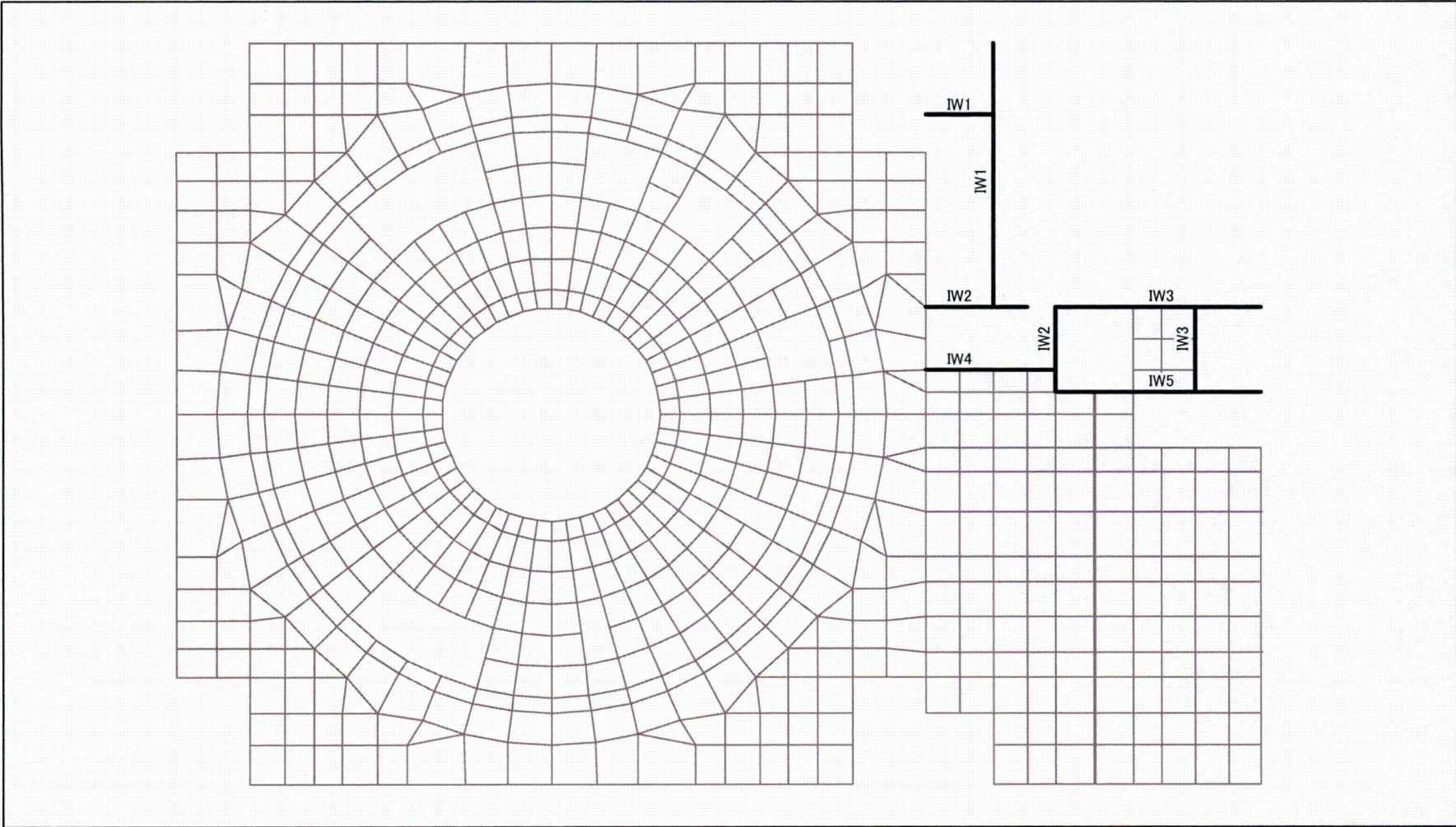
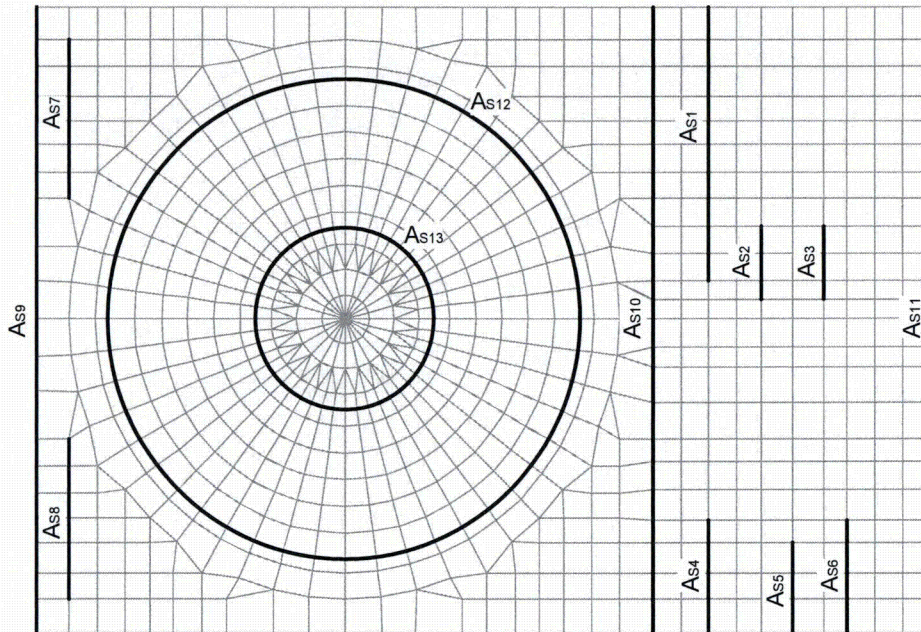


Figure 6.2.3.9-5 Inner Walls Where Shear Force Are Applied - EL-1,000~EL4,650



$$Q = Q_{RFBF} + Q_{RCCV} + Q_{PED}$$

$$A_S = \sum_{i=1}^n A_{Si}$$

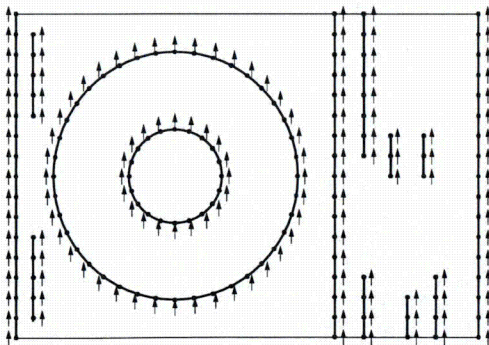
$$Q_{unit} = \frac{Q}{A_S}$$

$${}_i Q_{seismic} = A_{Si} \cdot Q_{unit} \quad (i = 1, n)$$

where, Q : Design Shear Force

A_{Si} : Shear Area of Each Seismic Wall

${}_i Q_{seismic}$: Shear Force Applied to Each Seismic Wall



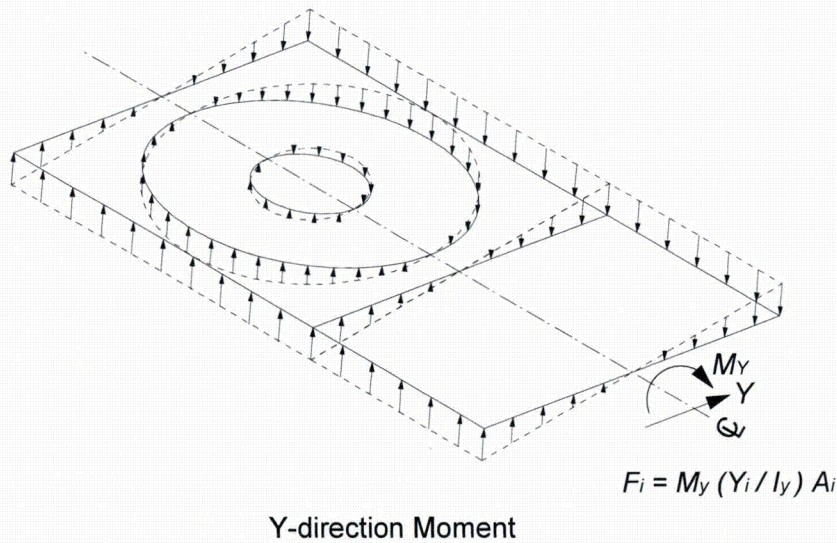
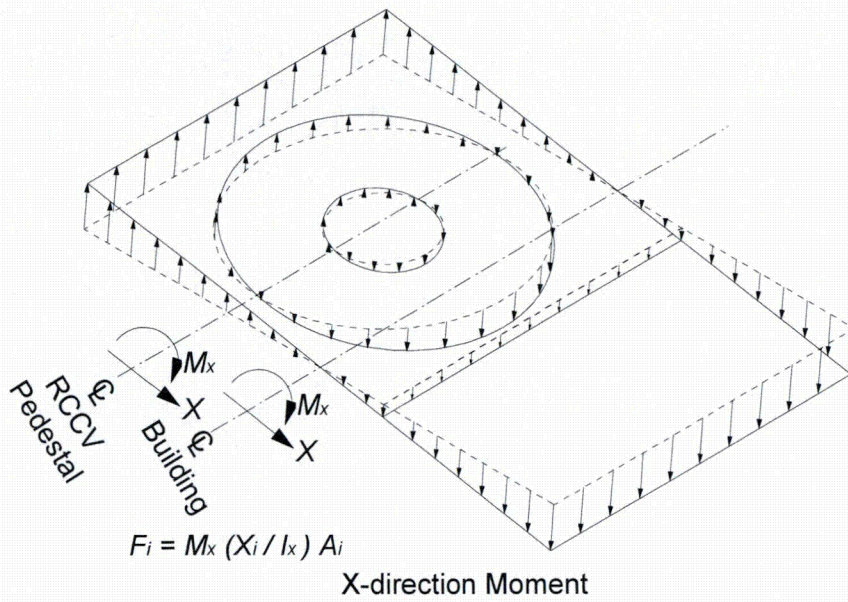
$${}_i Q_j = {}_i Q_{seismic} \times \frac{W_j}{\sum_{j=1}^m W_j} \quad i = 1, n$$

j : i -th Wall Grid Point

${}_i Q_j$: Shear Force Applied to Each Grid Point

W_j : Weight of Each Grid Point

Figure 6.2.3.9-6 Distribution of Seismic Shear Forces



- F_i : Force applied to Grid Point
- M_x, M_y : Overturning moment
- I_x, I_y : Moment inertia of total walls
- X_i, Y_i : Distance from the center line to each wall
- A_i : Tributary wall area at the Grid Point

Figure 6.2.3.9-7 Method of Applying Overturning Moments



HITACHI

WG3-U71-ERD-S-0004 SH NO. 429
REV. 0 of 538

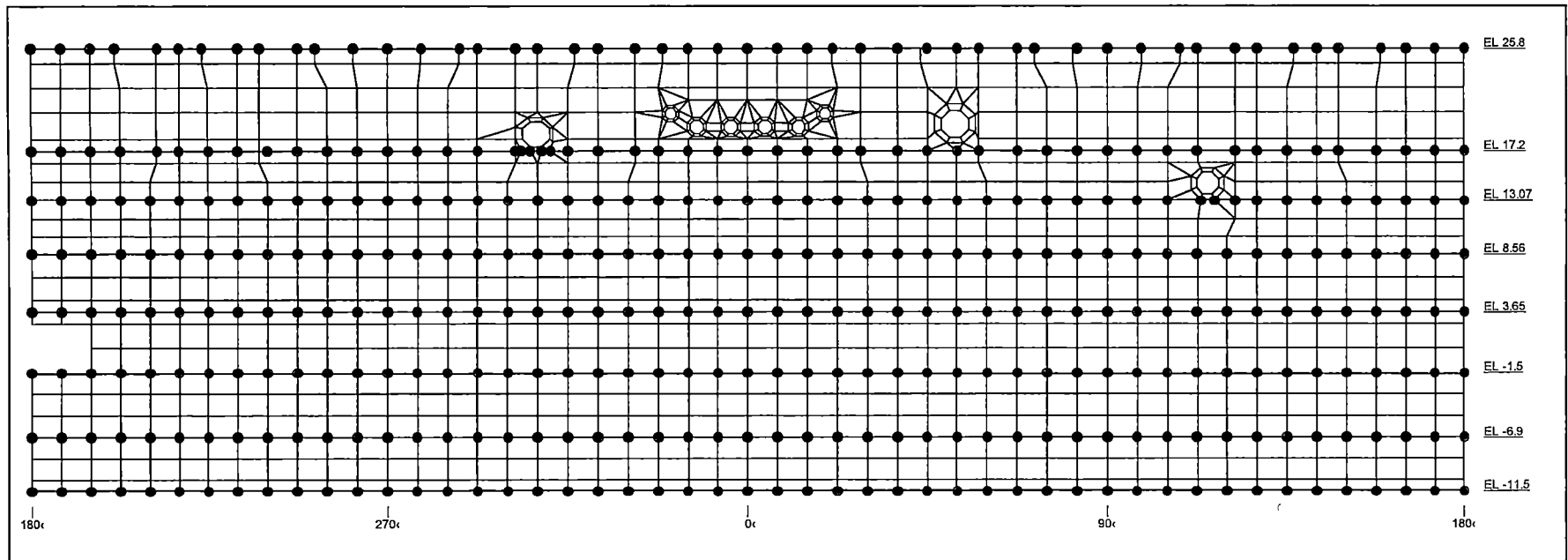


Figure 6.2.3.9-8 Application of Overturning Moments to the RCCV and Wall below RCCV



HITACHI

WG3-U71-ERD-S-0004 SH NO. 430
REV. 0 of 538

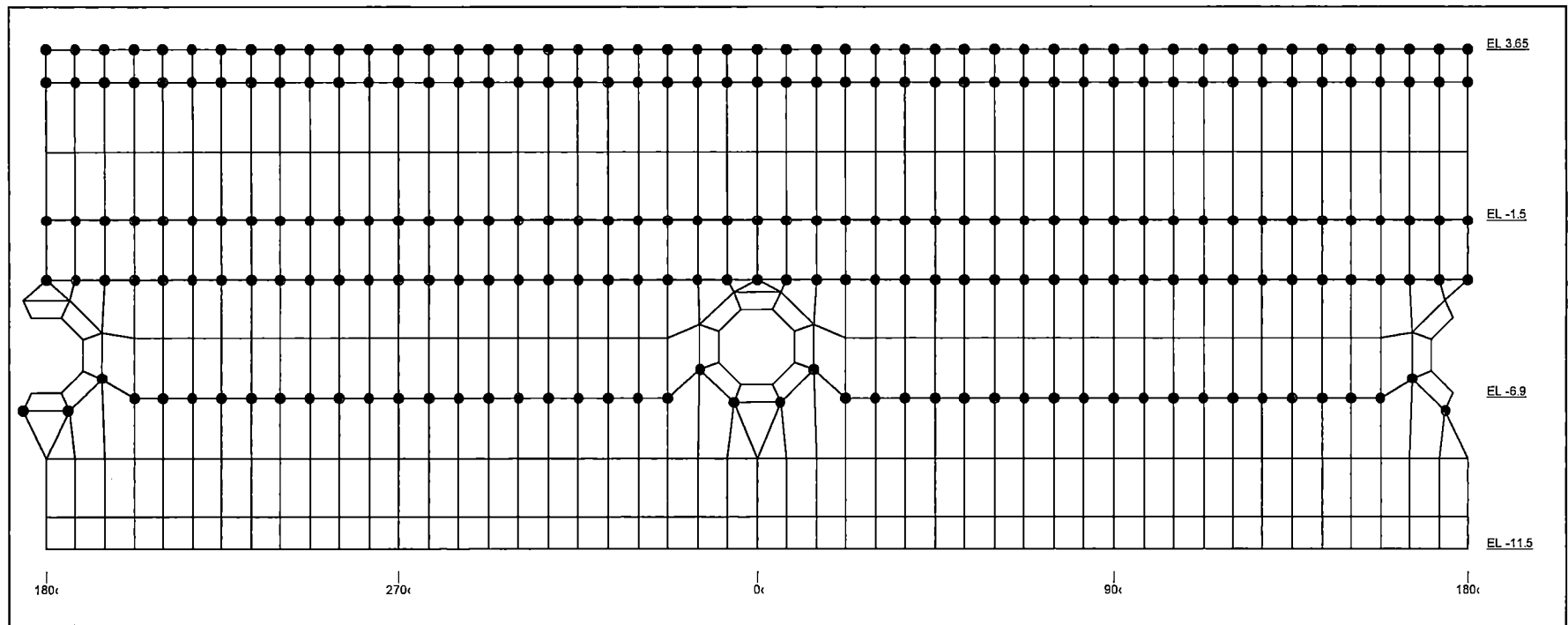


Figure 6.2.3.9-9 Application of Overturning Moments to the RPV Pedestal



HITACHI

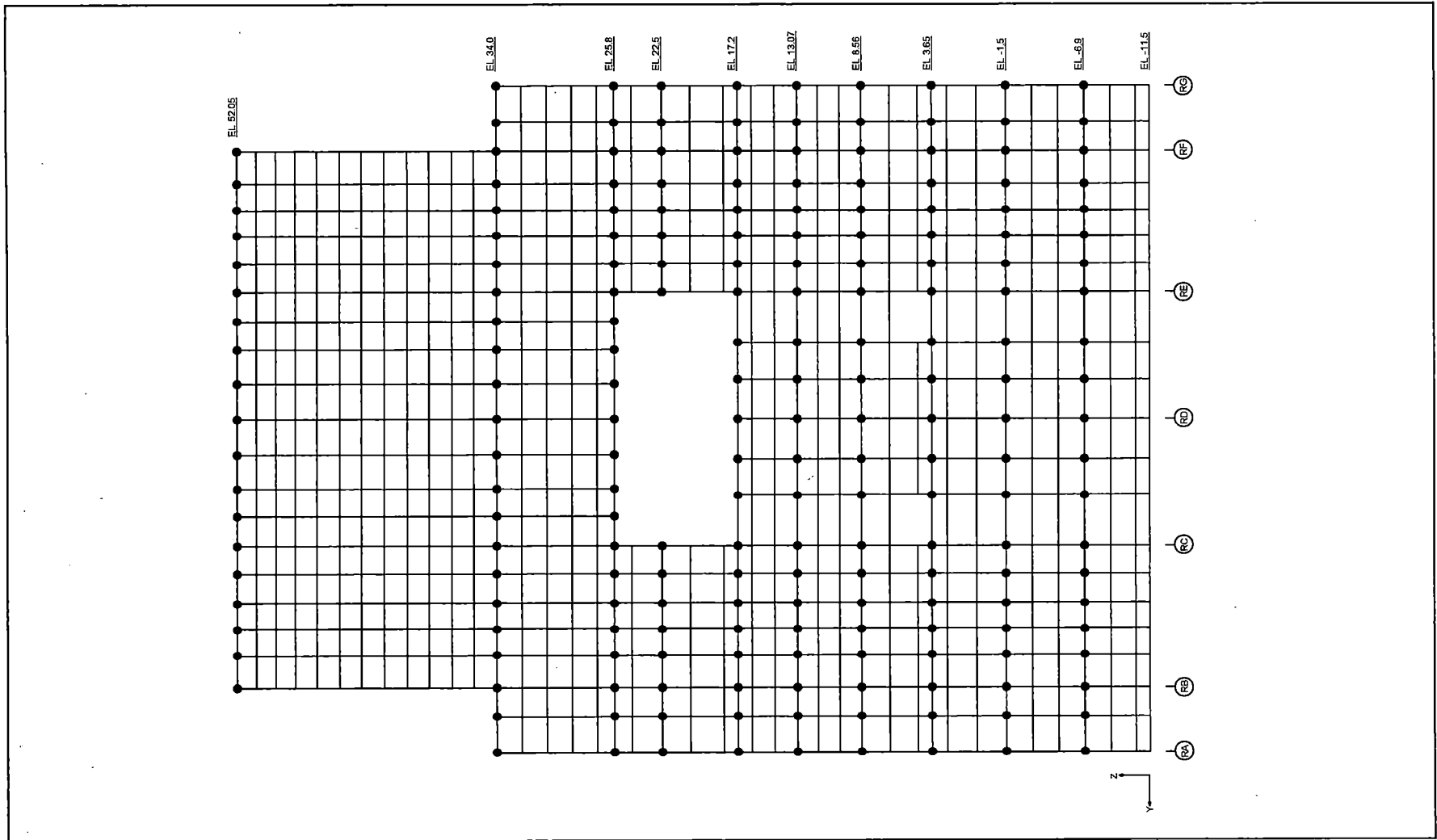


Figure 6.2.3.9-10 Application of Overturning Moments to the External Wall on R1 Column Line

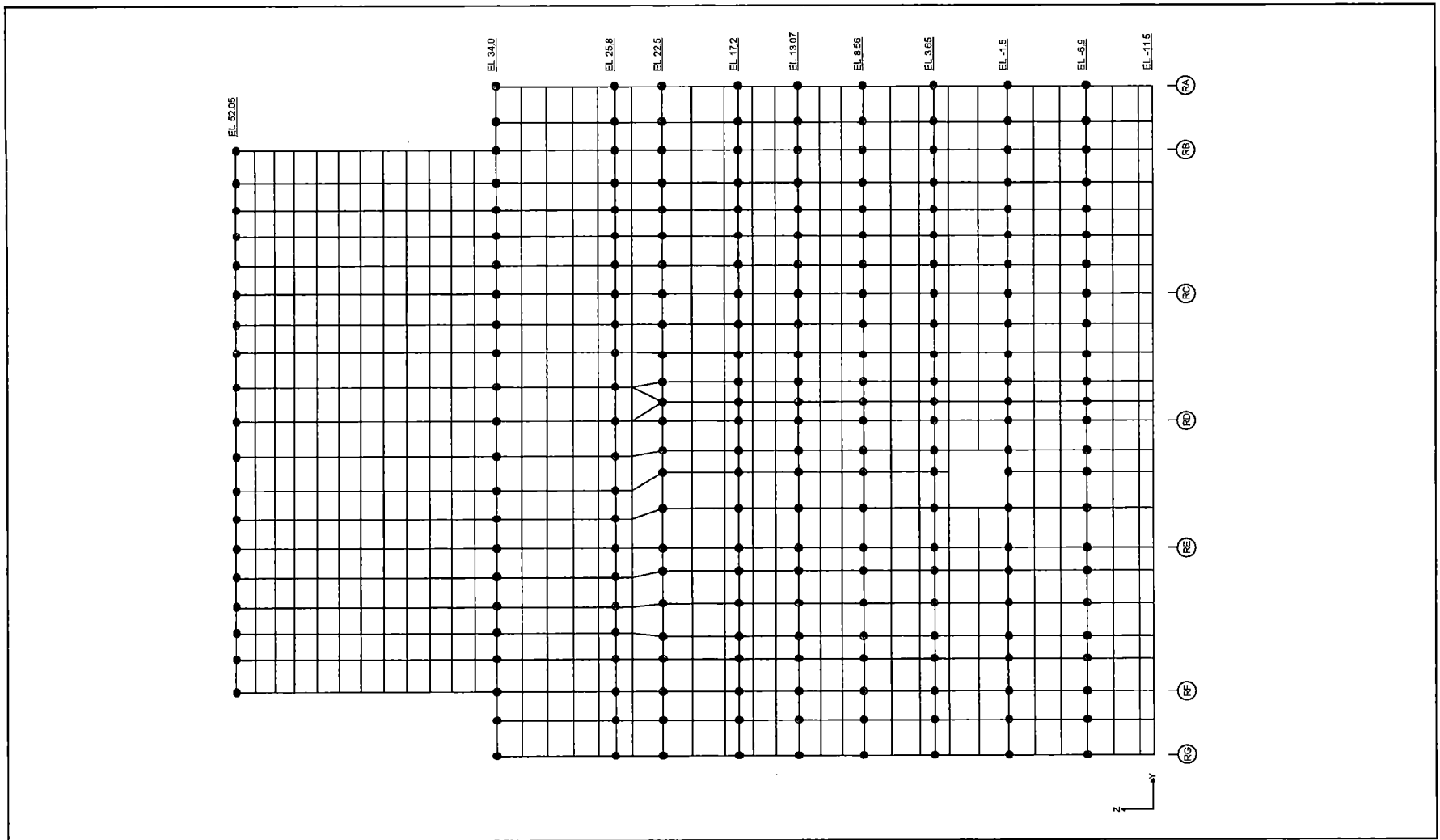


Figure 6.2.3.9-11 Application of Overturning Moments to the External Wall on R7 Column Line

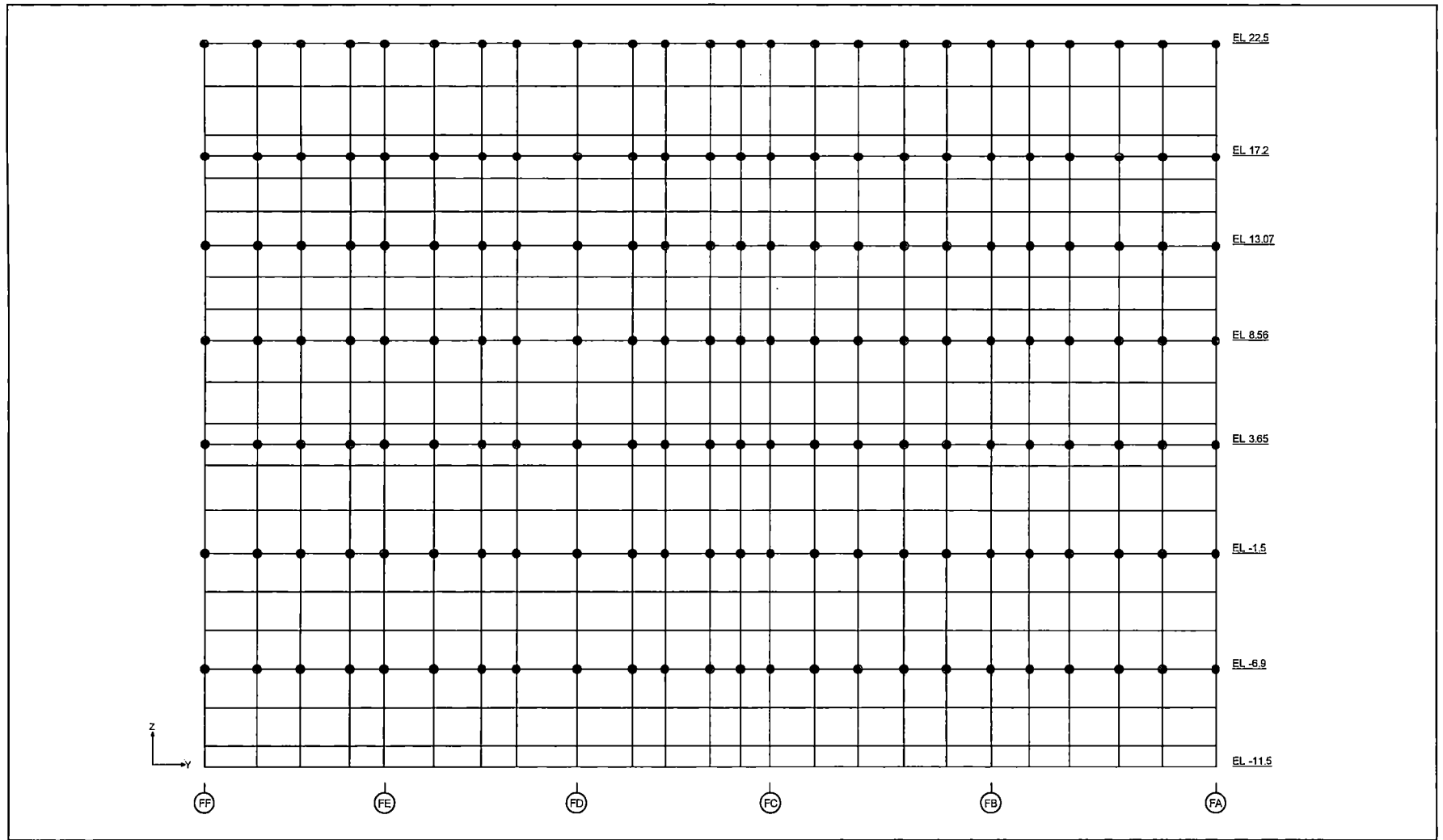


Figure 6.2.3.9-12 Application of Overturning Moments to the External Wall on F3 Column Line



HITACHI

WG3-U71-ERD-S-0004

SH NO. 434

REV. 0

of 538

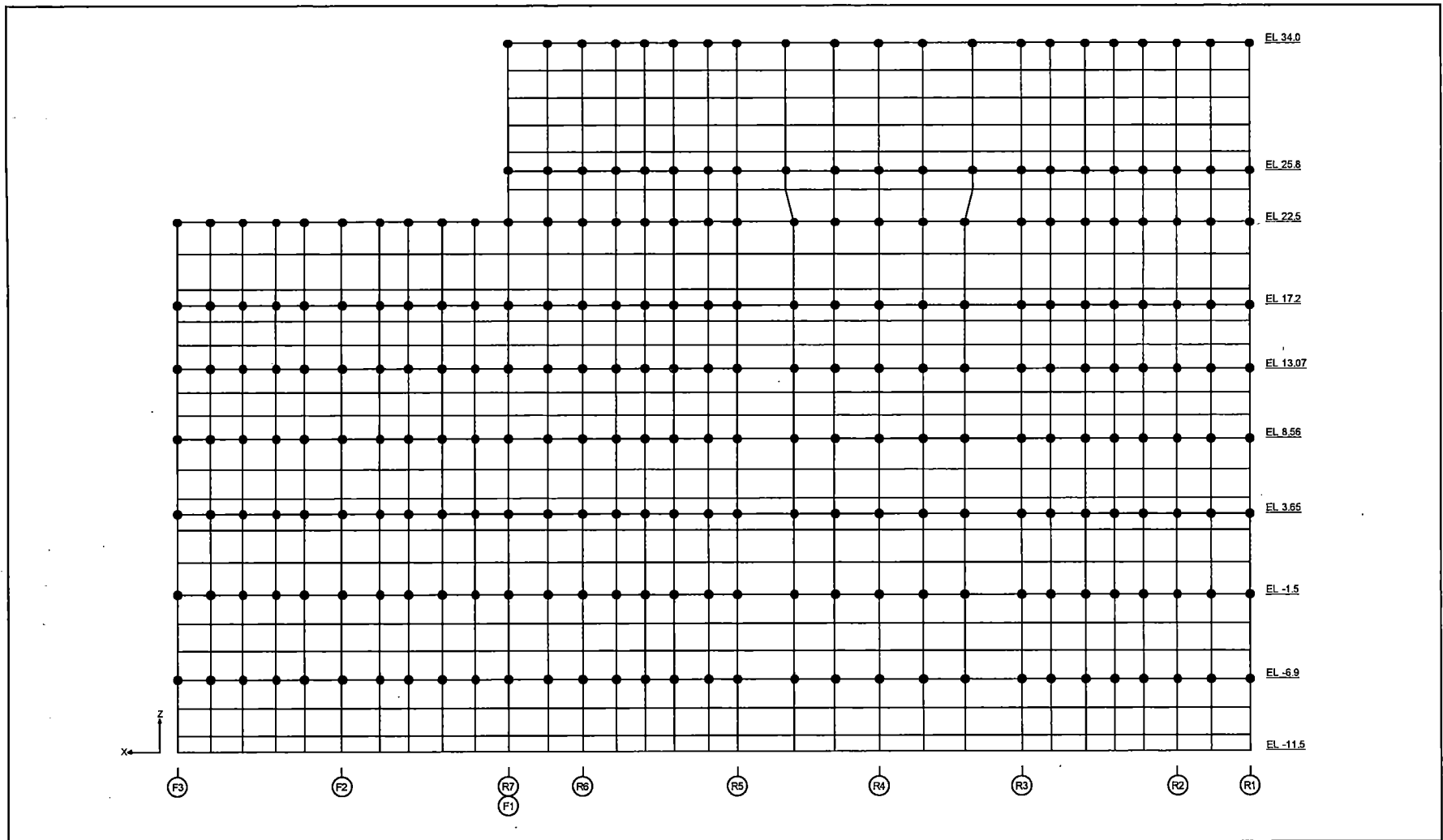


Figure 6.2.3.9-13 Application of Overturning Moments to the External Wall on RA Column Line



HITACHI

WG3-U71-ERD-S-0004 SH NO. 435
REV. 0 of 538

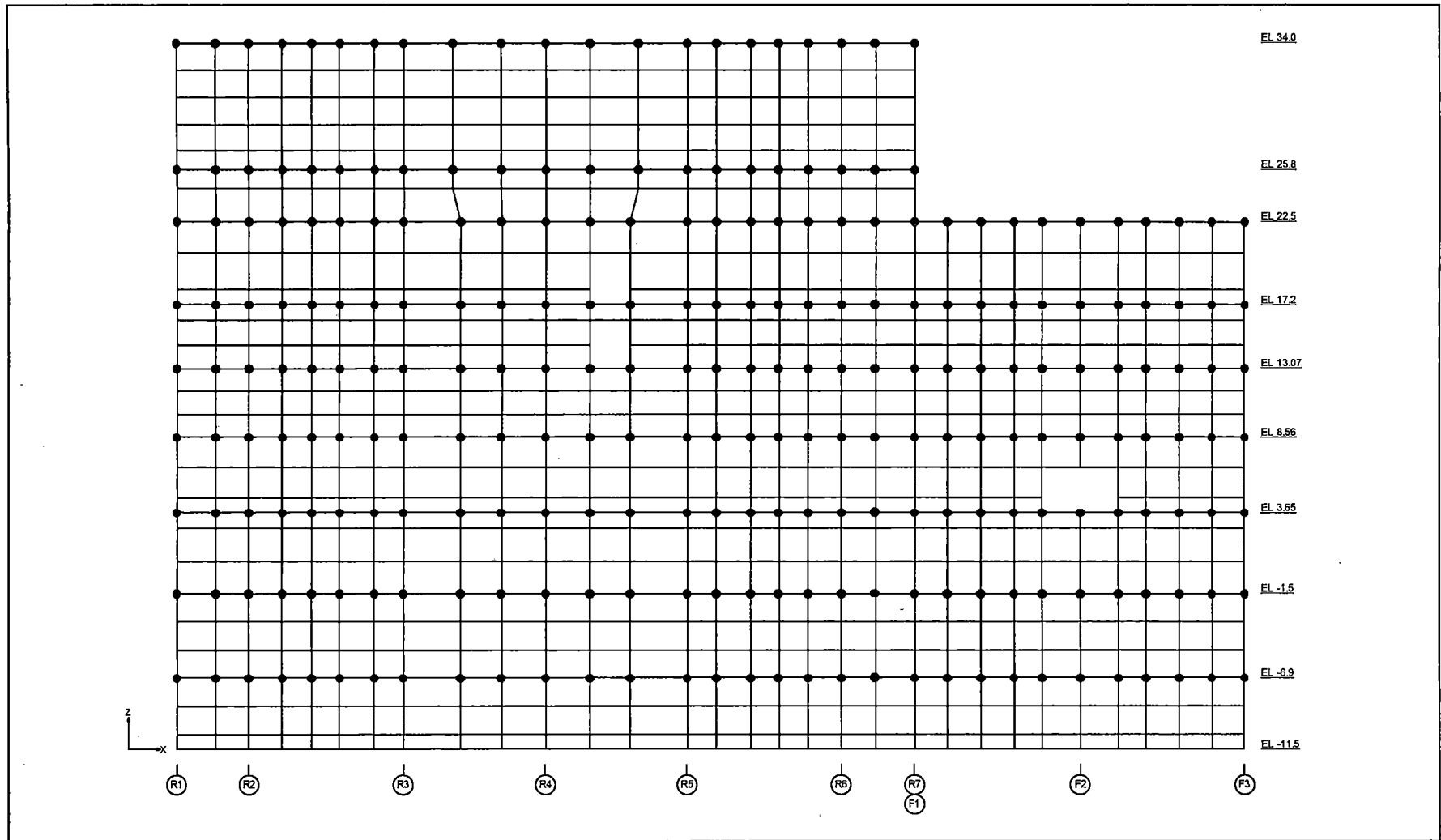


Figure 6.2.3.9-14 Application of Overturning Moments to the External Wall on RG Column Line



HITACHI

WG3-U71-ERD-S-0004 SH NO. 436
REV. 0 of 538

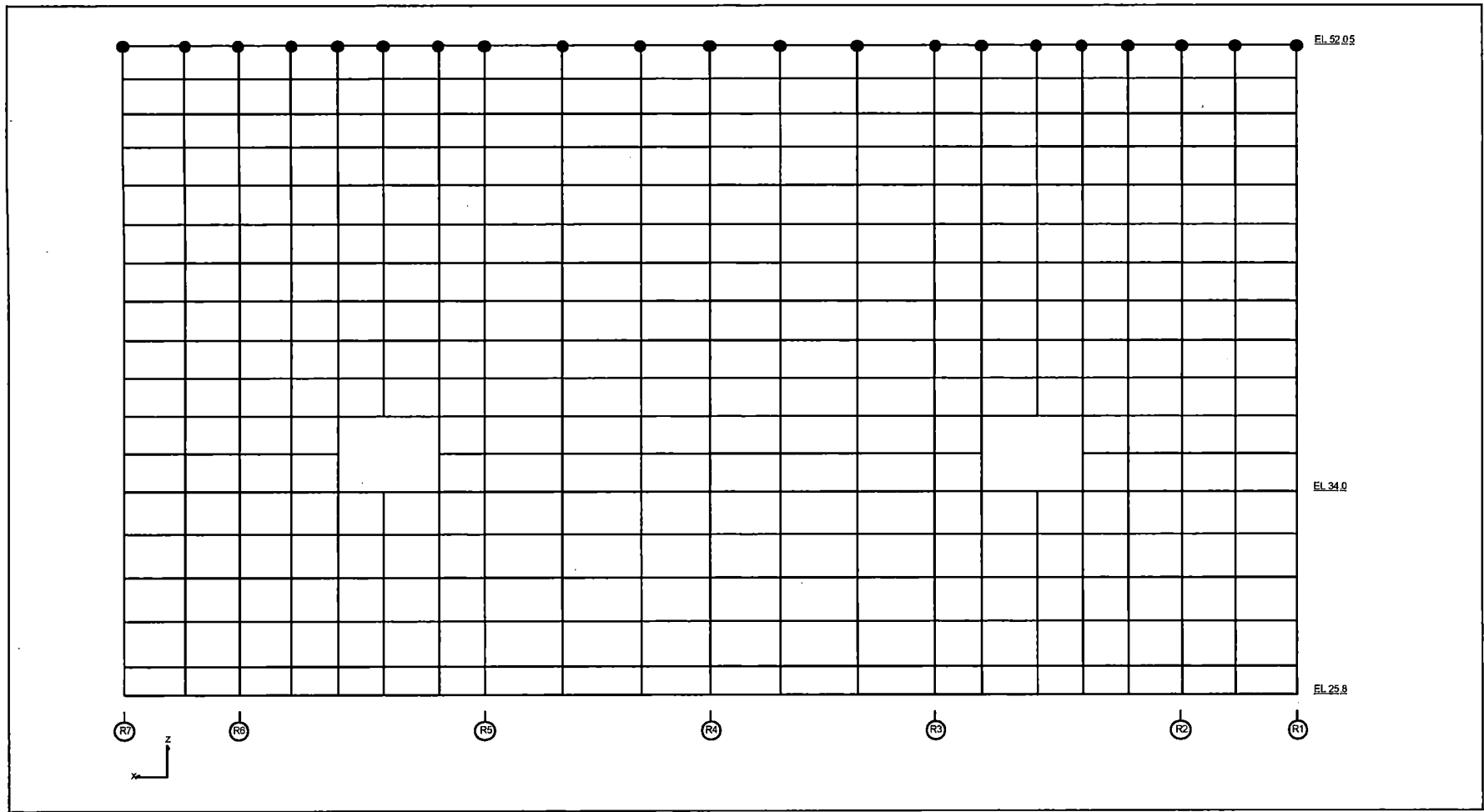


Figure 6.2.3.9-15 Application of Overturning Moments to the External Wall on RB Column Line



HITACHI

WG3-U71-ERD-S-0004

SH NO. 437

REV. 0

of 538

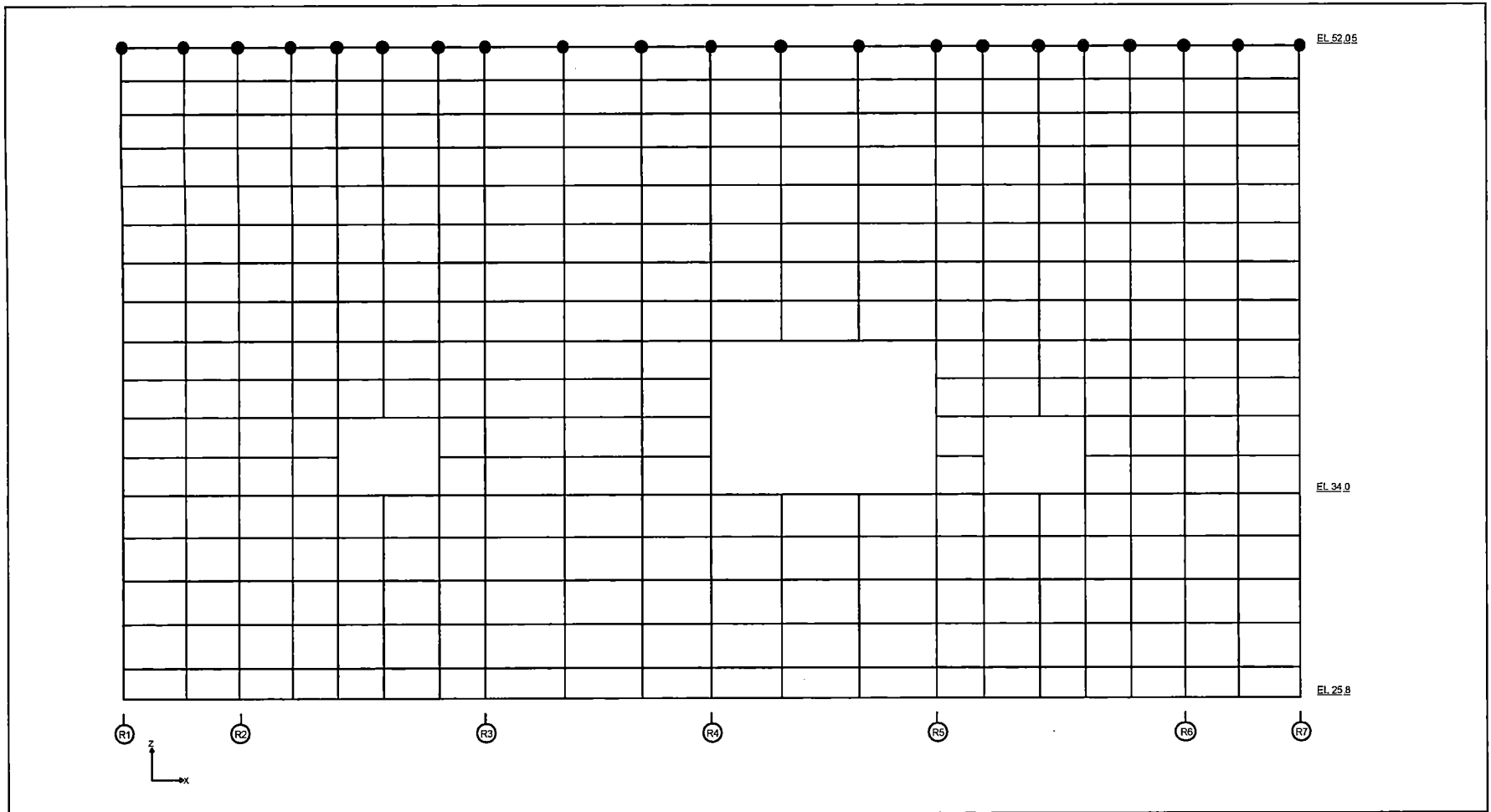


Figure 6.2.3.9-16 Application of Overturning Moments to the External Wall on RF Column Line

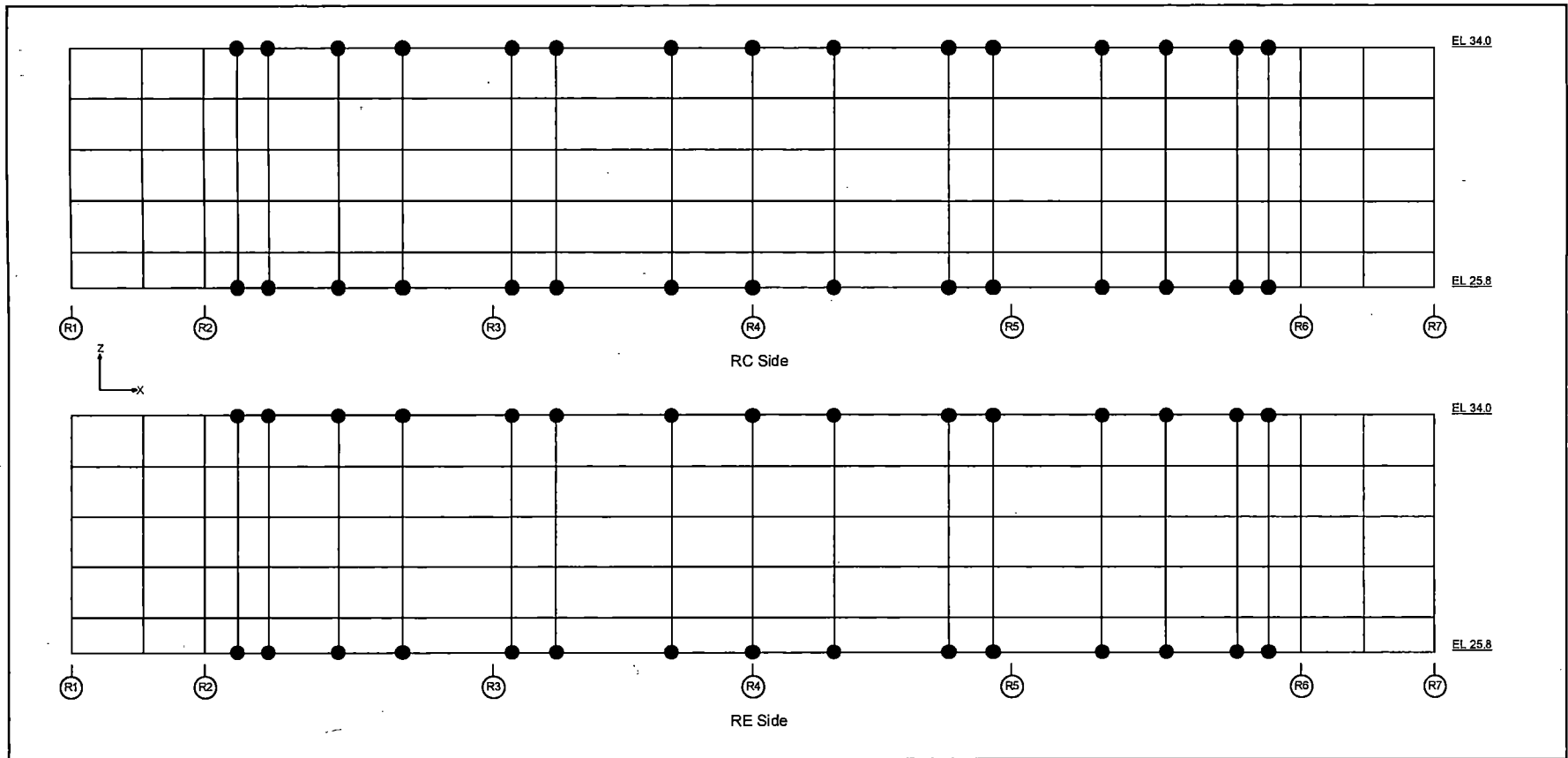
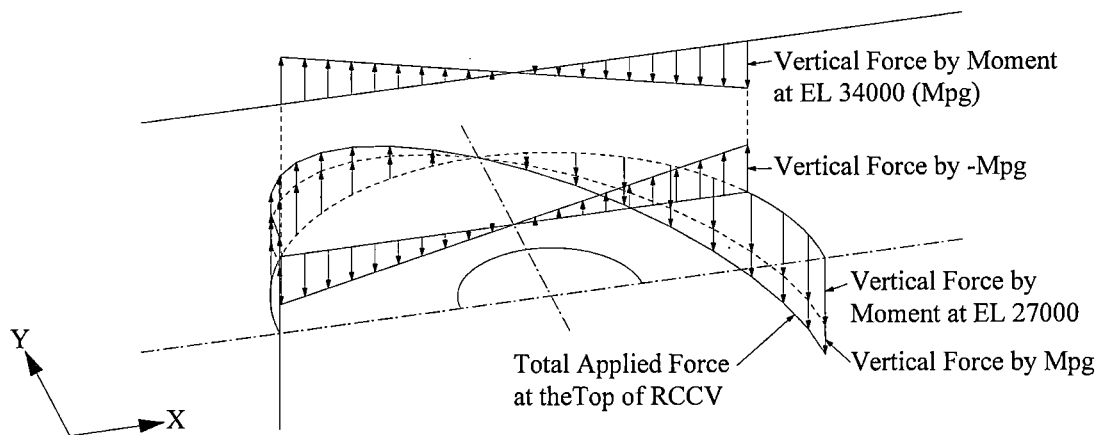
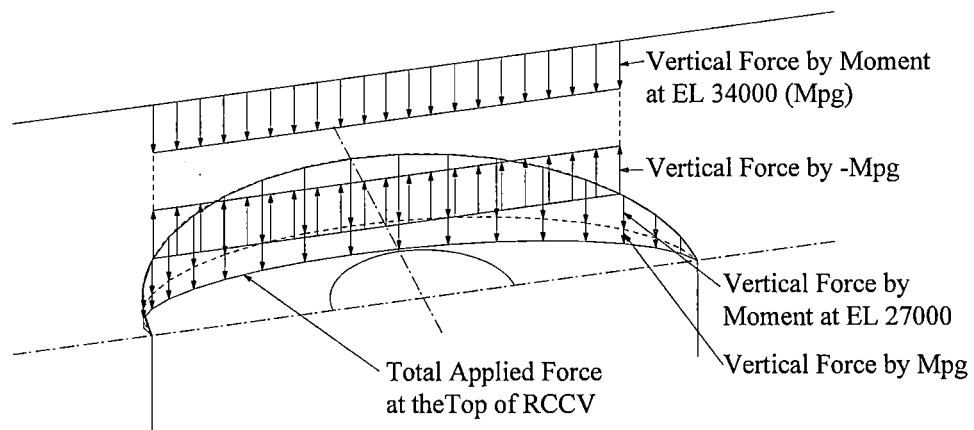


Figure 6.2.3.9-17 Application of Overturning Moments to the Pool Girders



X-direction Moment



Y-direction Moment

Note: Above figures show the east side half of RCCV

Figure 6.2.3.9-18 Method of Applying Overturning Moments to the Top of RCCV

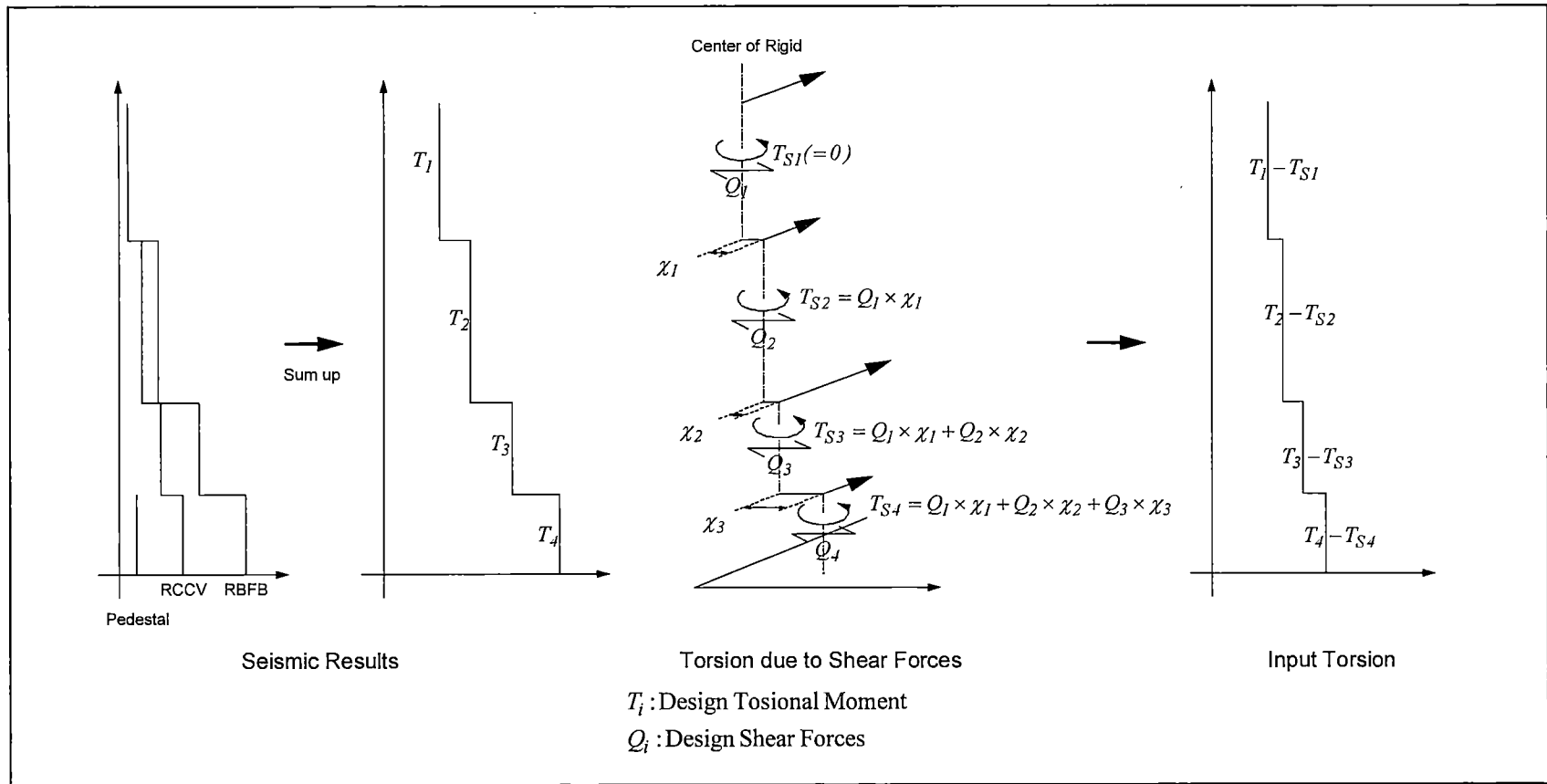
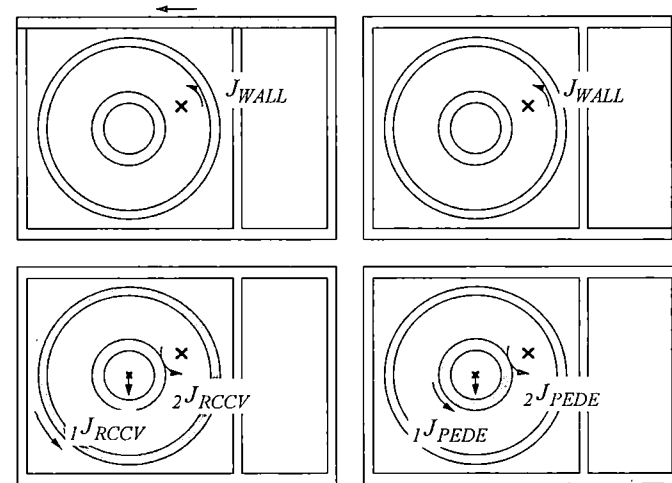
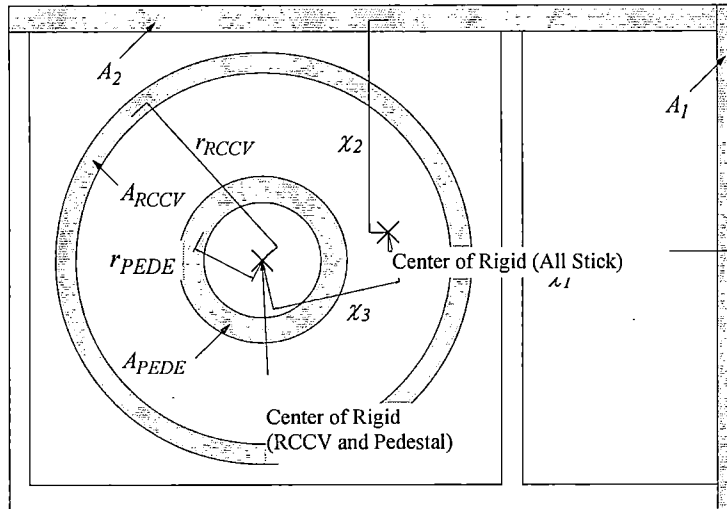


Figure 6.2.3.9-19 Calculation Method of Input Torsional Moment



$$J_{WALL} = \sum_{j=1}^m (A_j \times \chi_j^2)$$

$${}_1J_{RCCV} = A_{RCCV} \times r_{RCCV}^2$$

$${}_2J_{RCCV} = \frac{A_{RCCV}}{2} \times \chi_3^2$$

$${}_1J_{PEDE} = A_{PEDE} \times r_{PEDE}^2$$

$${}_2J_{PEDE} = \frac{A_{PEDE}}{2} \times \chi_3^2$$

$$J_{ALL} = J_{WALL} + {}_1J_{RCCV} + {}_2J_{RCCV} + {}_1J_{PEDE} + {}_2J_{PEDE}$$

$${}_jT_{input} = \frac{(T_i - T_{Si})}{J_{ALL}} \times {}_jJ_{WALL} \quad (j = 1, m)$$

$${}_{RCCV}T_{input} = \frac{(T_i - T_{Si})}{J_{ALL}} \times ({}_1J_{RCCV} + {}_2J_{RCCV})$$

$${}_{PEDE}T_{input} = \frac{(T_i - T_{Si})}{J_{ALL}} \times ({}_1J_{PEDE} + {}_2J_{PEDE})$$

$(T_i - T_{Si})$: Input Torsion (Refer to Figure 6.2.3.9-19.)

Figure 6.2.3.9-20 Calculation Method of Shear Forces due to Torsional Moment



HITACHI

WG3-U71-ERD-S-0004

SH NO. 442

REV. 0

of 538

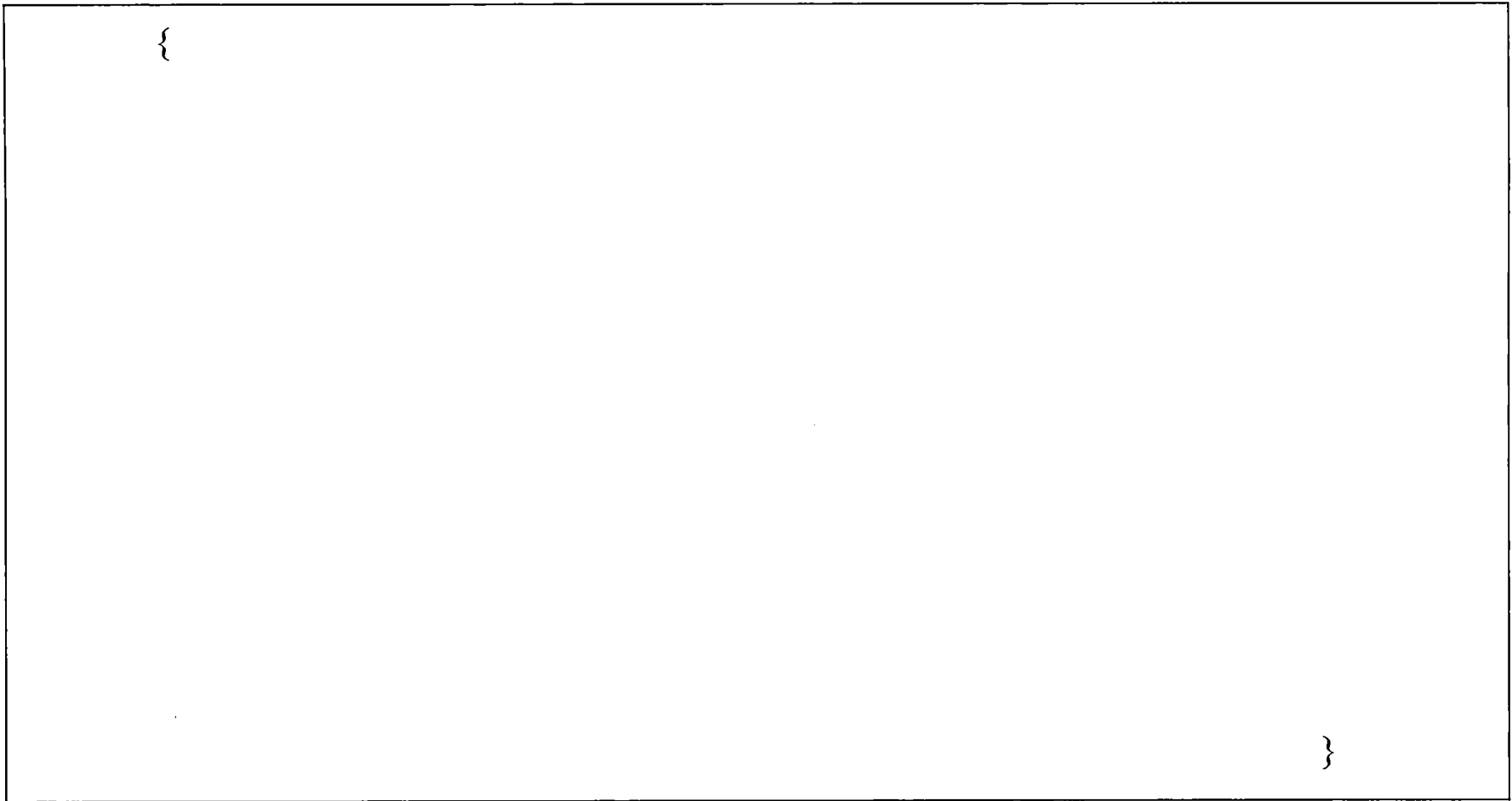


Figure 6.2.3.9-21 Soil Pressure Due to N-S Direction Earthquake on the Basemat

{{{Contains Security-Related Information – Withheld Under 10 CFR 2.390.}}}

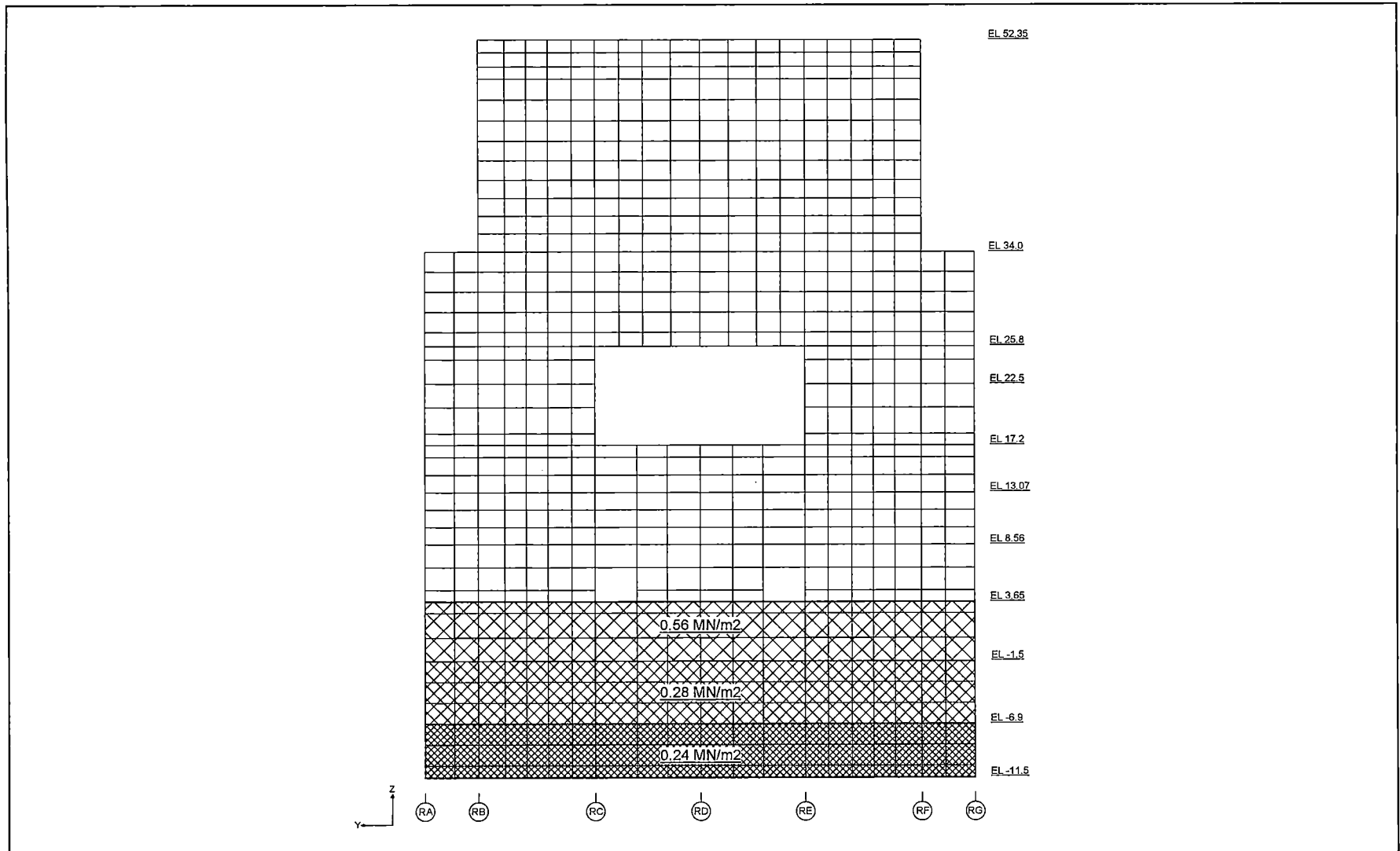


Figure 6.2.3.9-22 Soil Pressure Due to N-S Direction Earthquake on the External Wall (R1 Column Line)

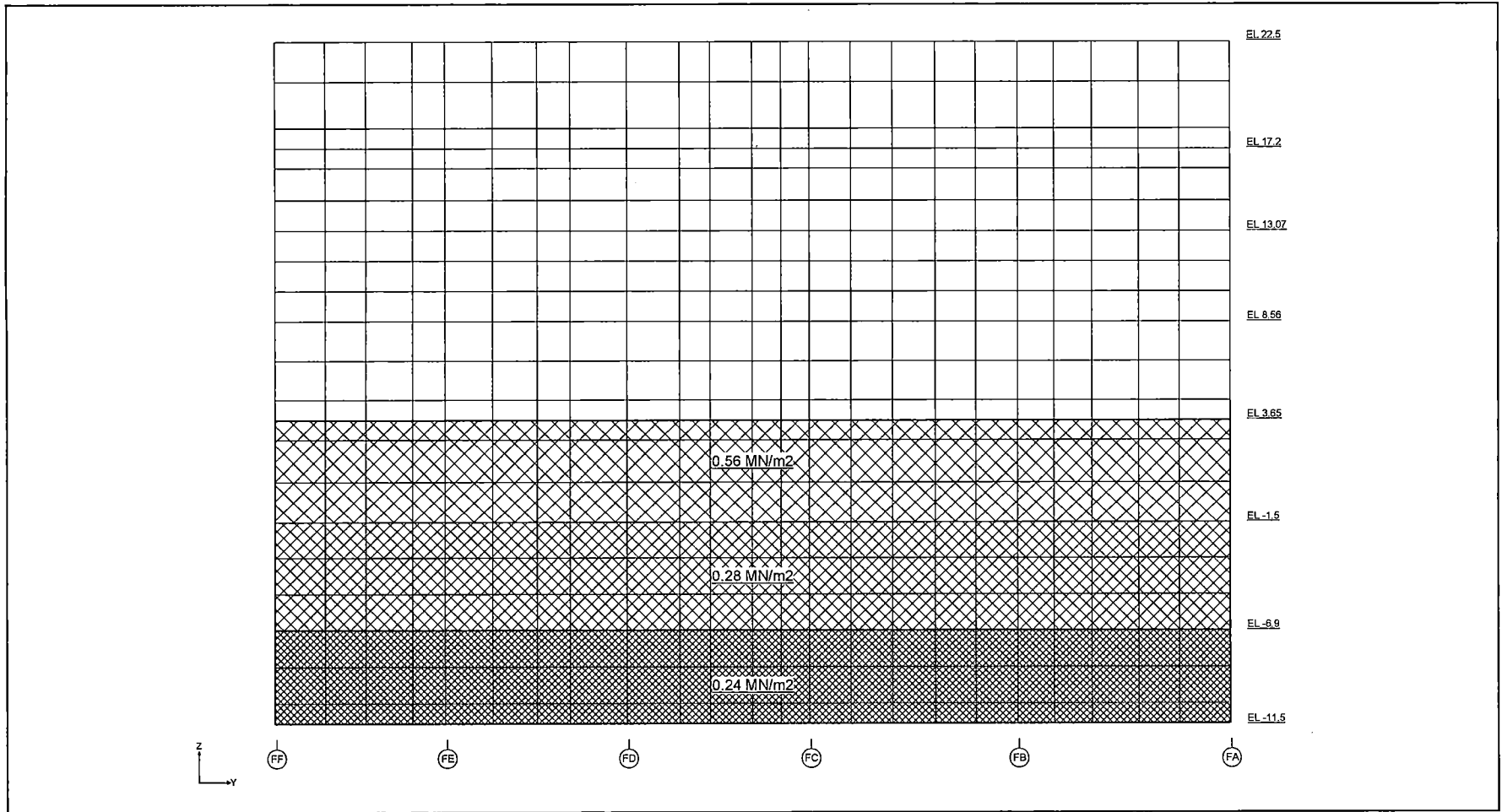


Figure 6.2.3.9-23 Soil Pressure Due to N-S Direction Earthquake on the External Wall (F3 Column Line)



HITACHI

WG3-U71-ERD-S-0004

SH NO. 445

REV. 0

of 538

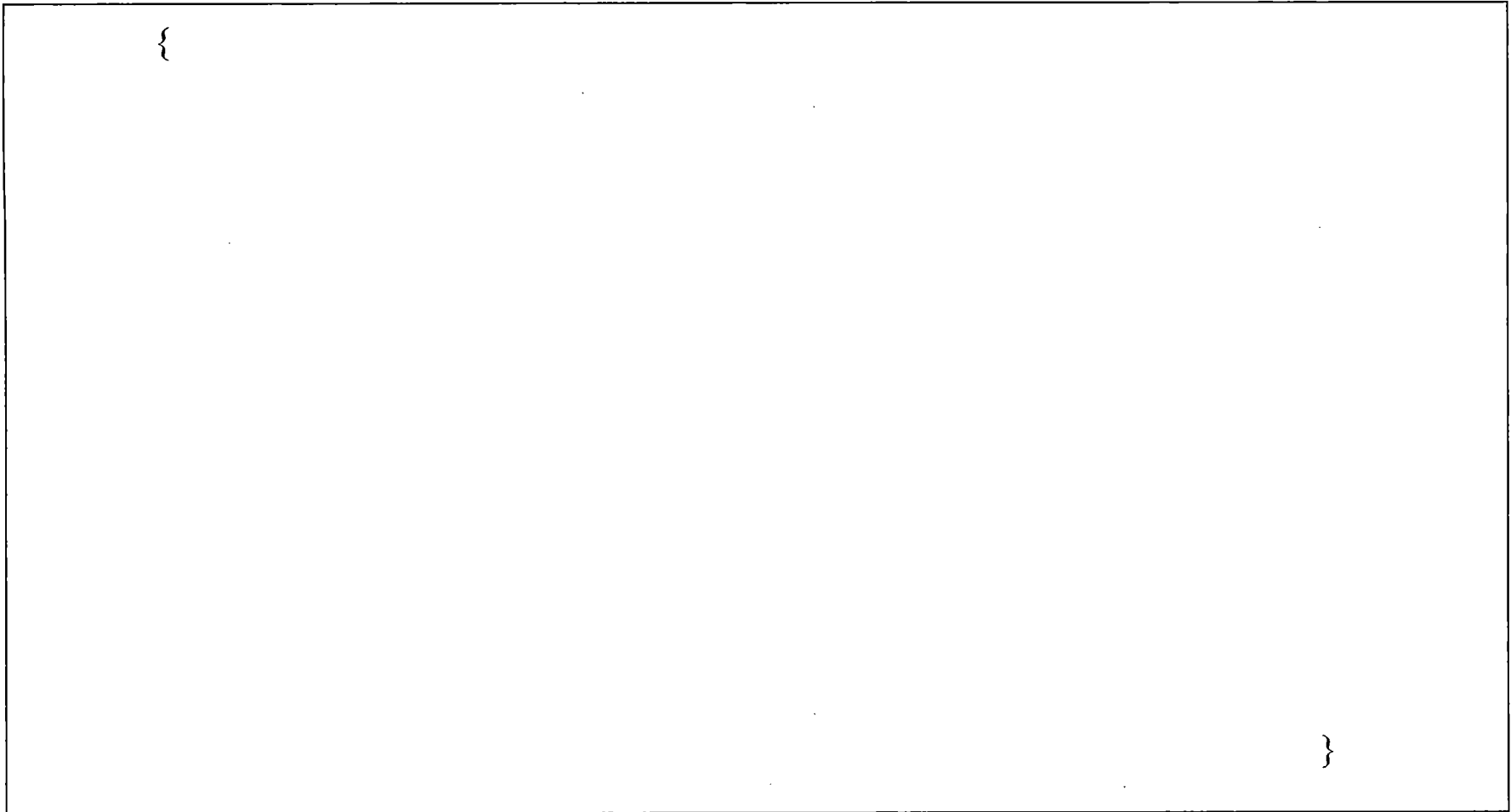


Figure 6.2.3.9-24 Soil Pressure Due to E-W Direction Earthquake on the Basemat

{{{Contains Security-Related Information – Withheld Under 10 CFR 2.390.}}}

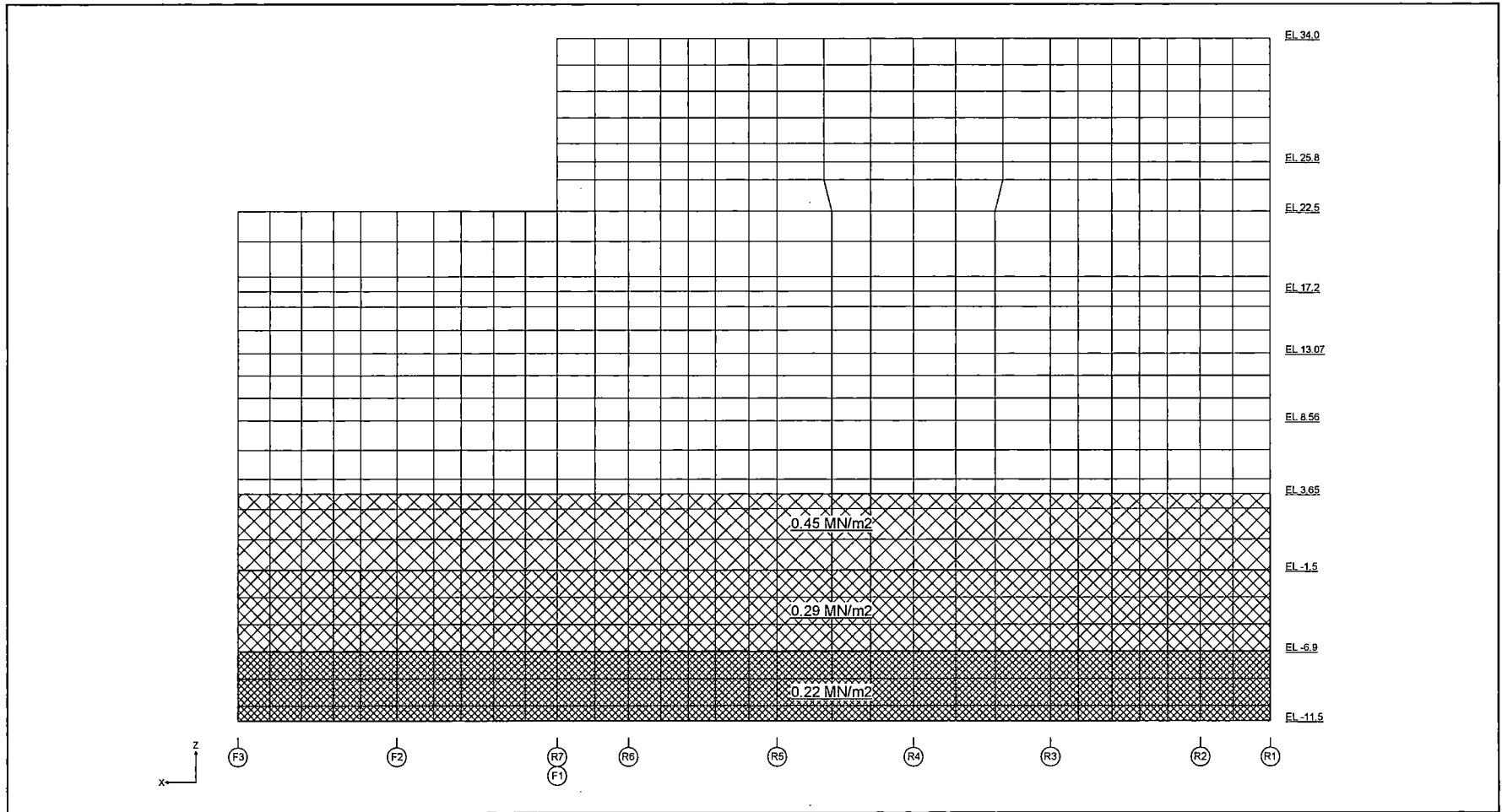


Figure 6.2.3.9-25 Soil Pressure Due to E-W Direction Earthquake on the External Wall (RA/FA Column Line)

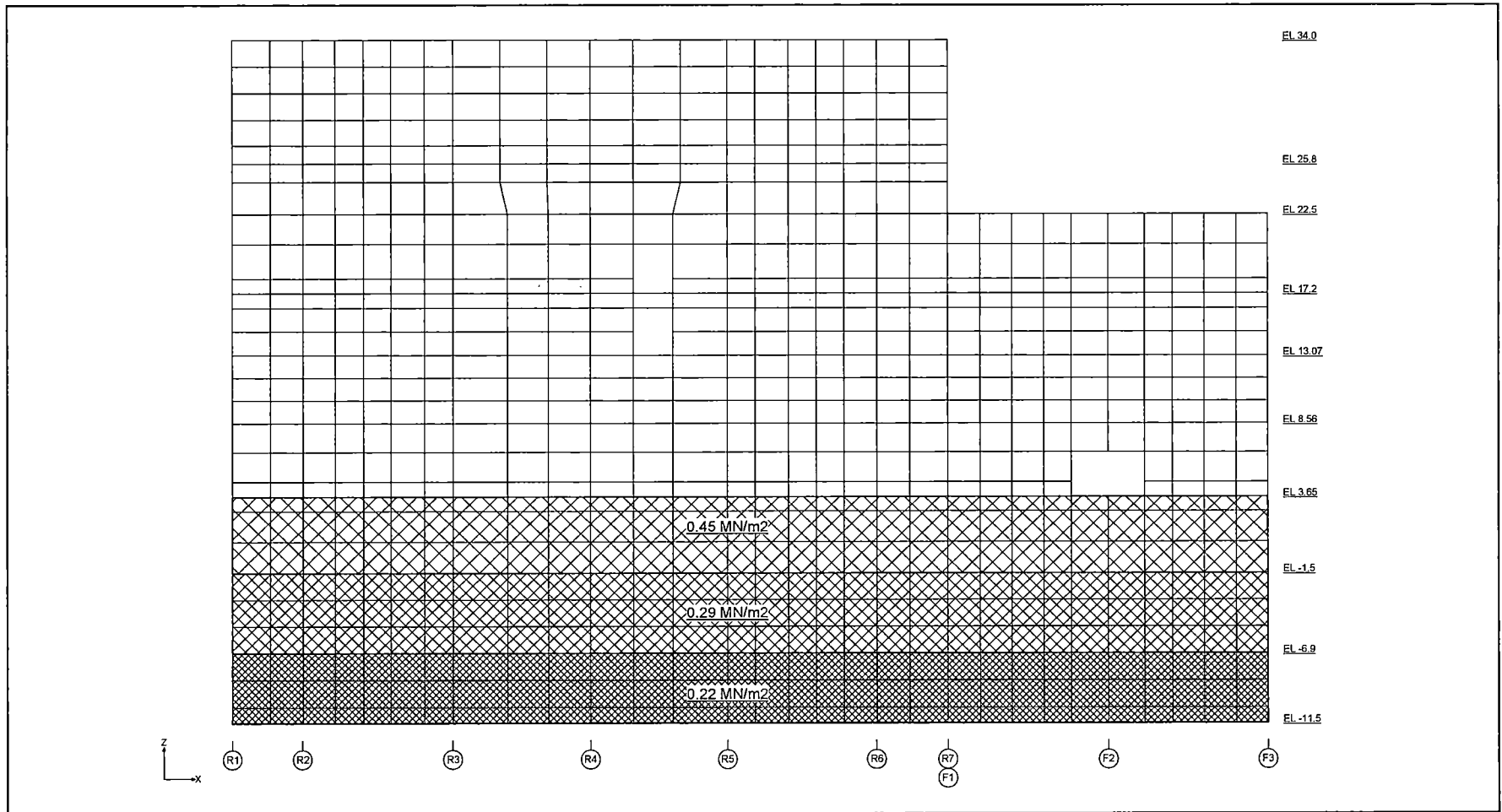


Figure 6.2.3.9-26 Soil Pressure Due to E-W Direction Earthquake on the External Wall (RG/FF Column Line)



HITACHI

WG3-U71-ERD-S-0004 SH NO. 448
REV. 0 of 538

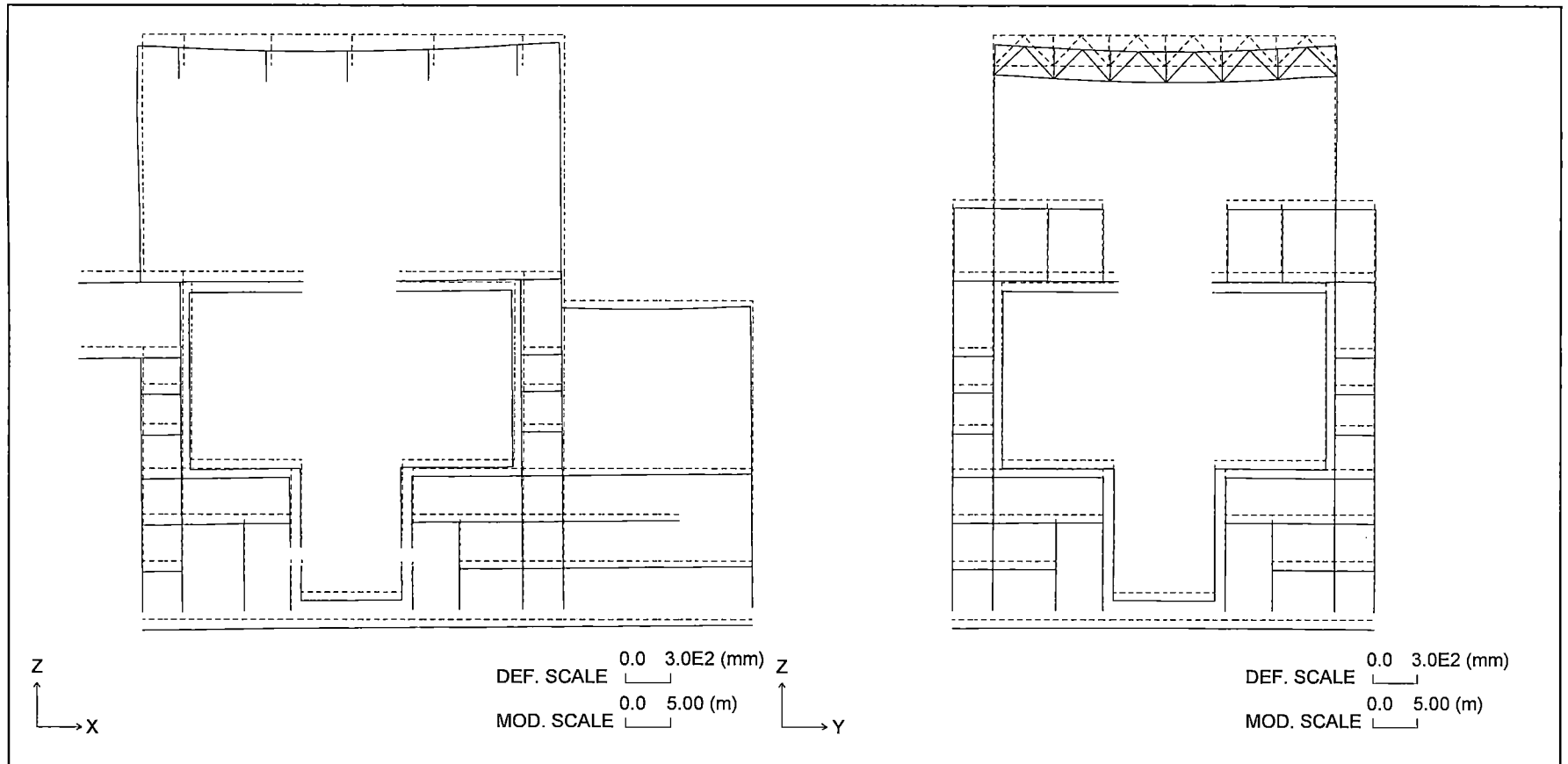


Figure 6.2.4-1 Section Deformation for Dead Load



HITACHI

WG3-U71-ERD-S-0004

SH NO. 449

REV. 0

of 538

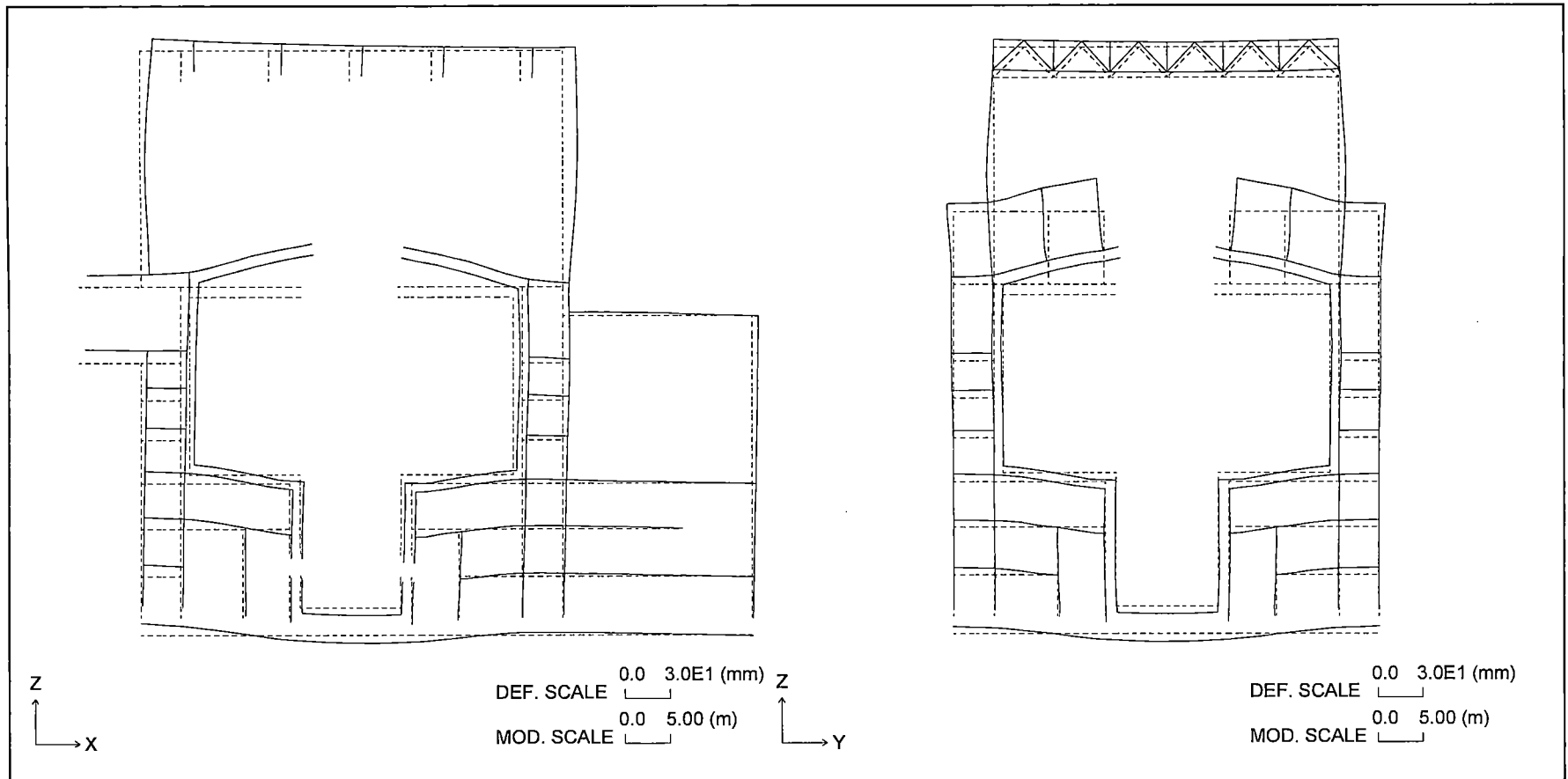


Figure 6.2.4-2 Section Deformation for Drywell Unit Pressure



HITACHI

WG3-U71-ERD-S-0004

SH NO. 450

REV. 0

of 538

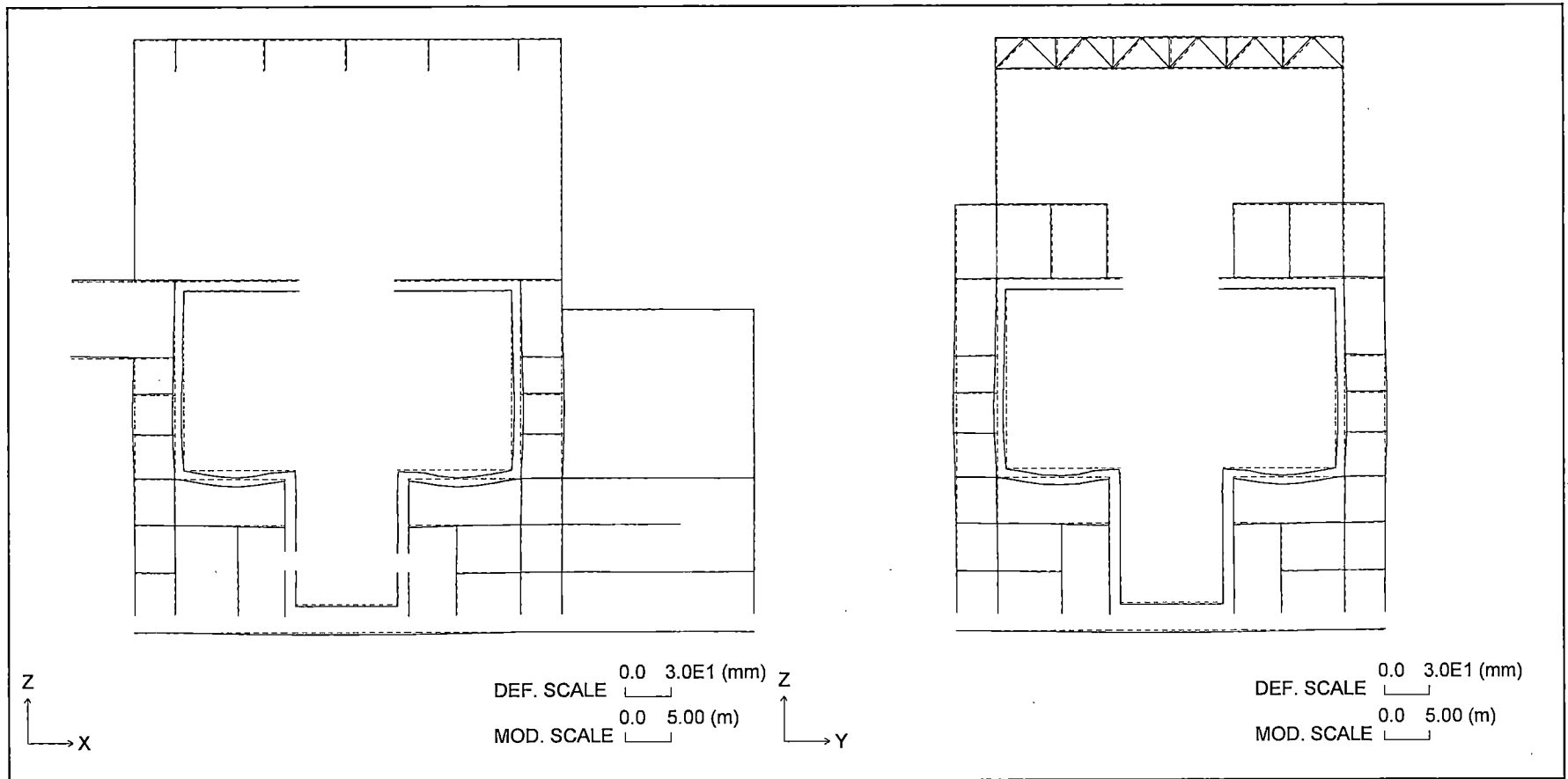


Figure 6.2.4-3 Section Deformation for Wetwell Unit Pressure (1 MPa)



HITACHI

WG3-U71-ERD-S-0004

SH NO. 451

REV. 0

of 538

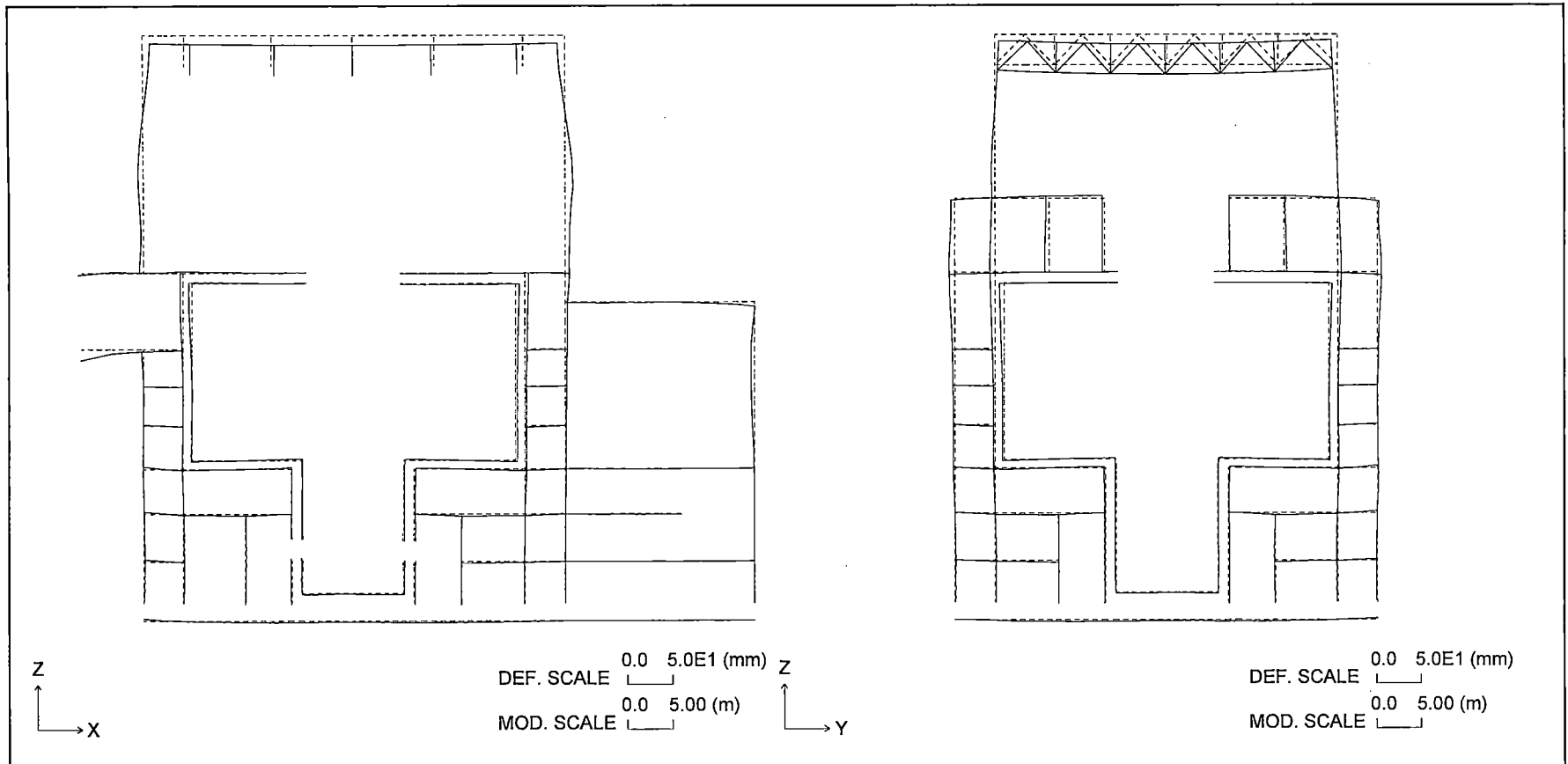


Figure 6.2.4-4 Section Deformation for Thermal Load (Normal Operation: Winter)



HITACHI

WG3-U71-ERD-S-0004 SH NO. 452
REV. 0 of 538

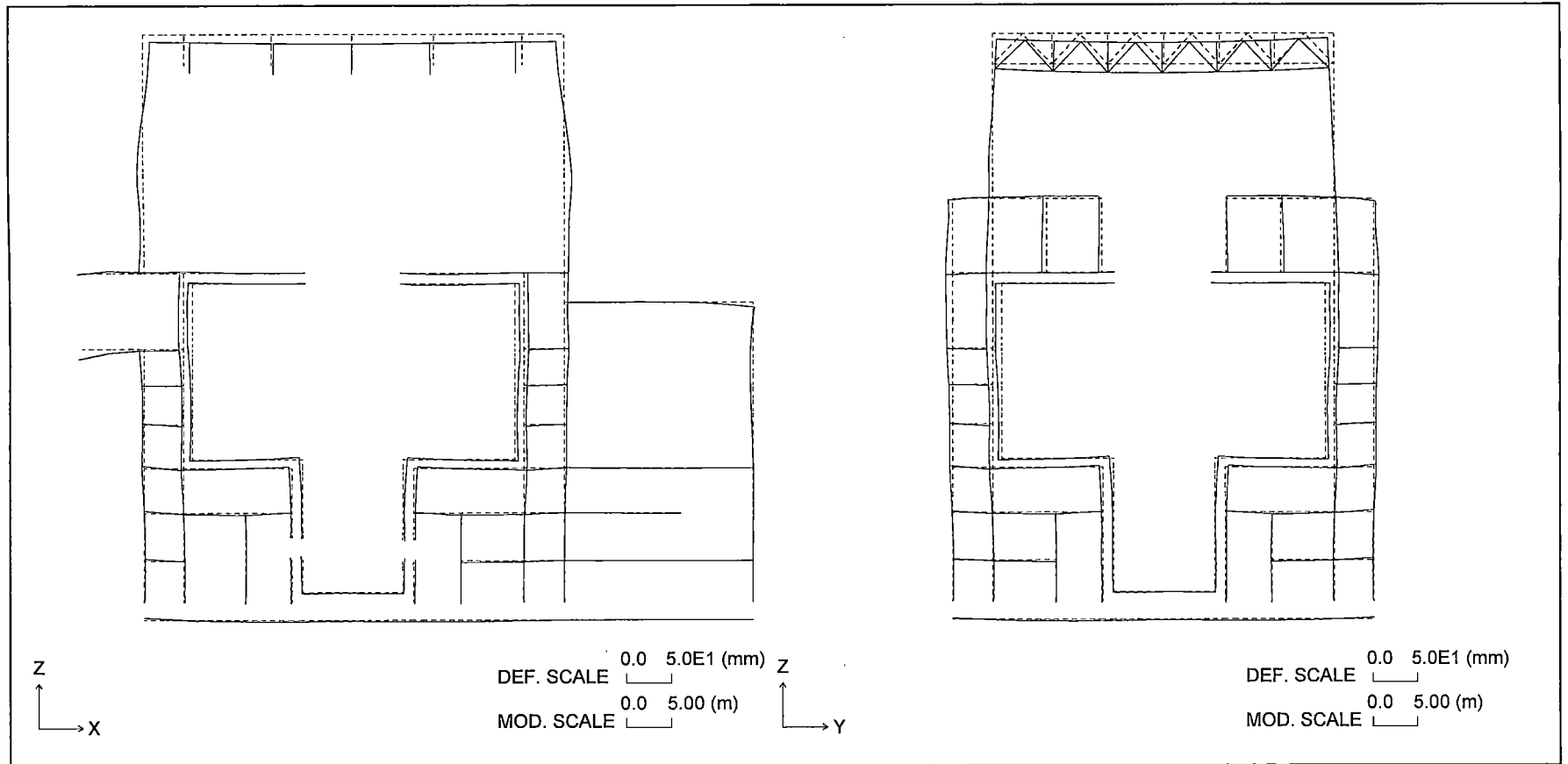


Figure 6.2.4-5 Section Deformation for Thermal Load (LOCA After 6 min.: Winter)



HITACHI

WG3-U71-ERD-S-0004 SH NO. 453
REV. 0 of 538

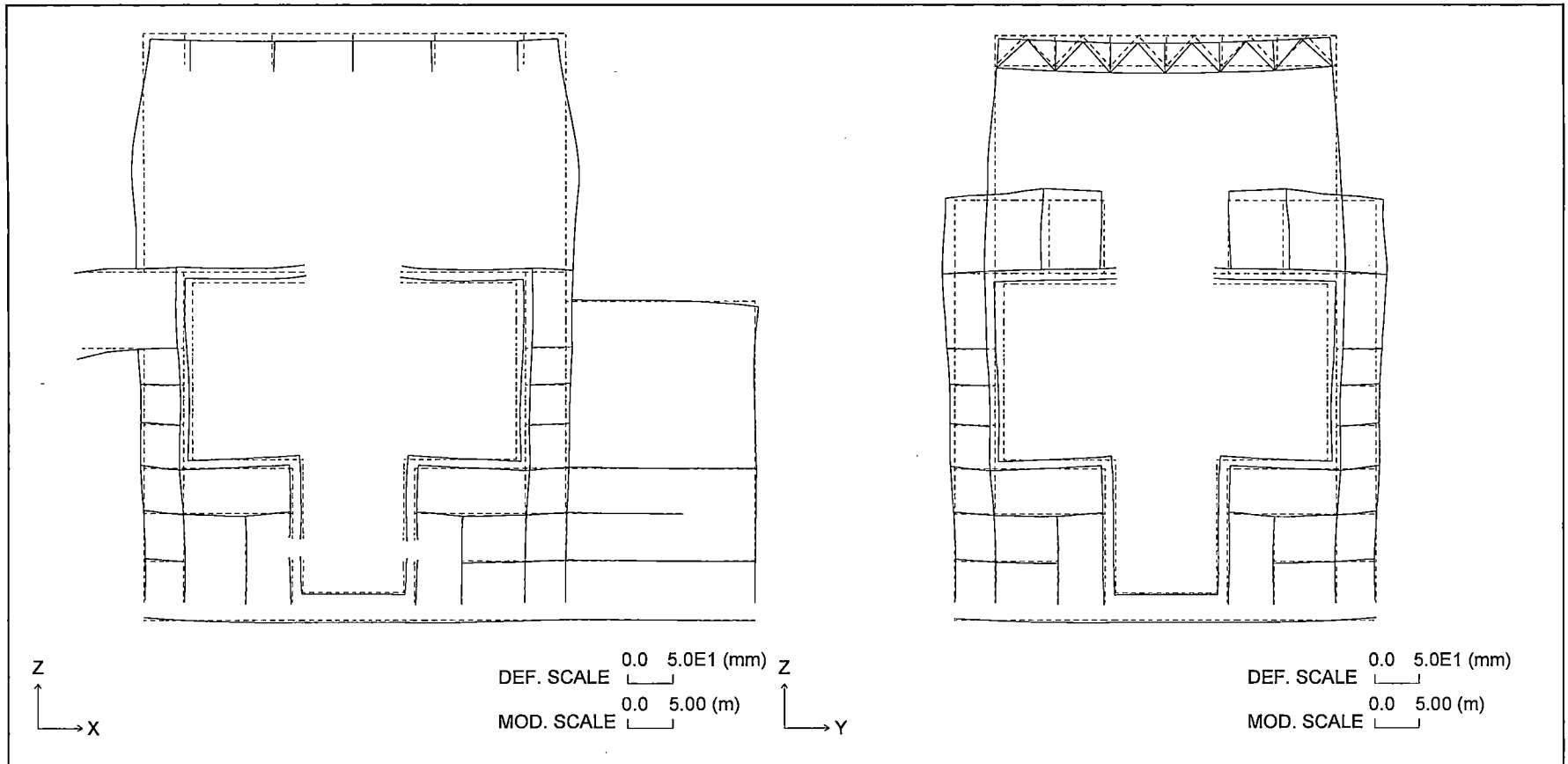


Figure 6.2.4-6 Section Deformation for Thermal Load (LOCA After 72 hr.: Winter)



HITACHI

WG3-U71-ERD-S-0004

SH NO. 454

REV. 0

of 538

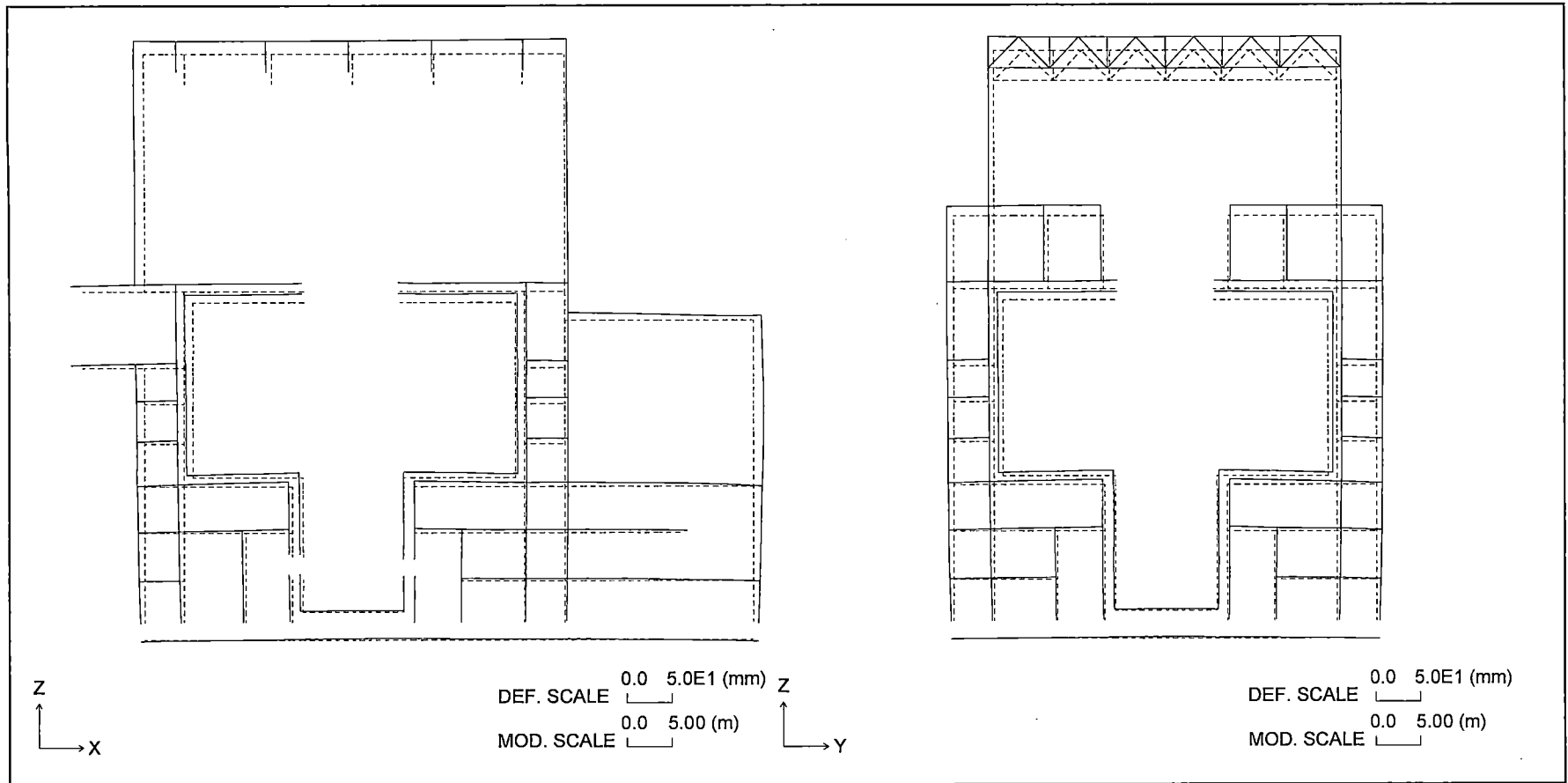


Figure 6.2.4-7 Section Deformation for Thermal Load (Normal Operation: Summer)

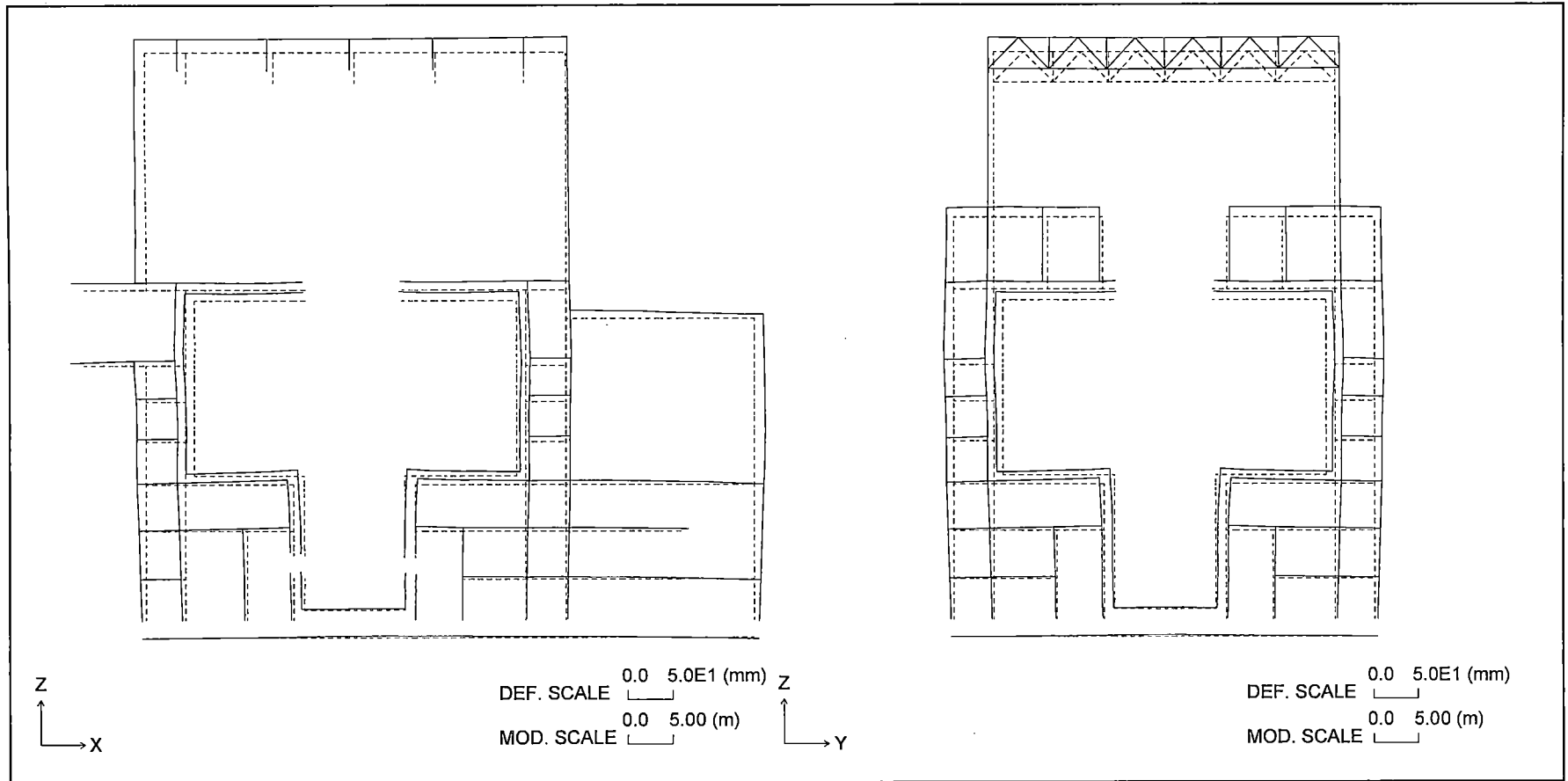


Figure 6.2.4-8 Section Deformation for Thermal Load (LOCA After 6 min.: Summer)



HITACHI

WG3-U71-ERD-S-0004

SH NO. 456

REV. 0

of 538

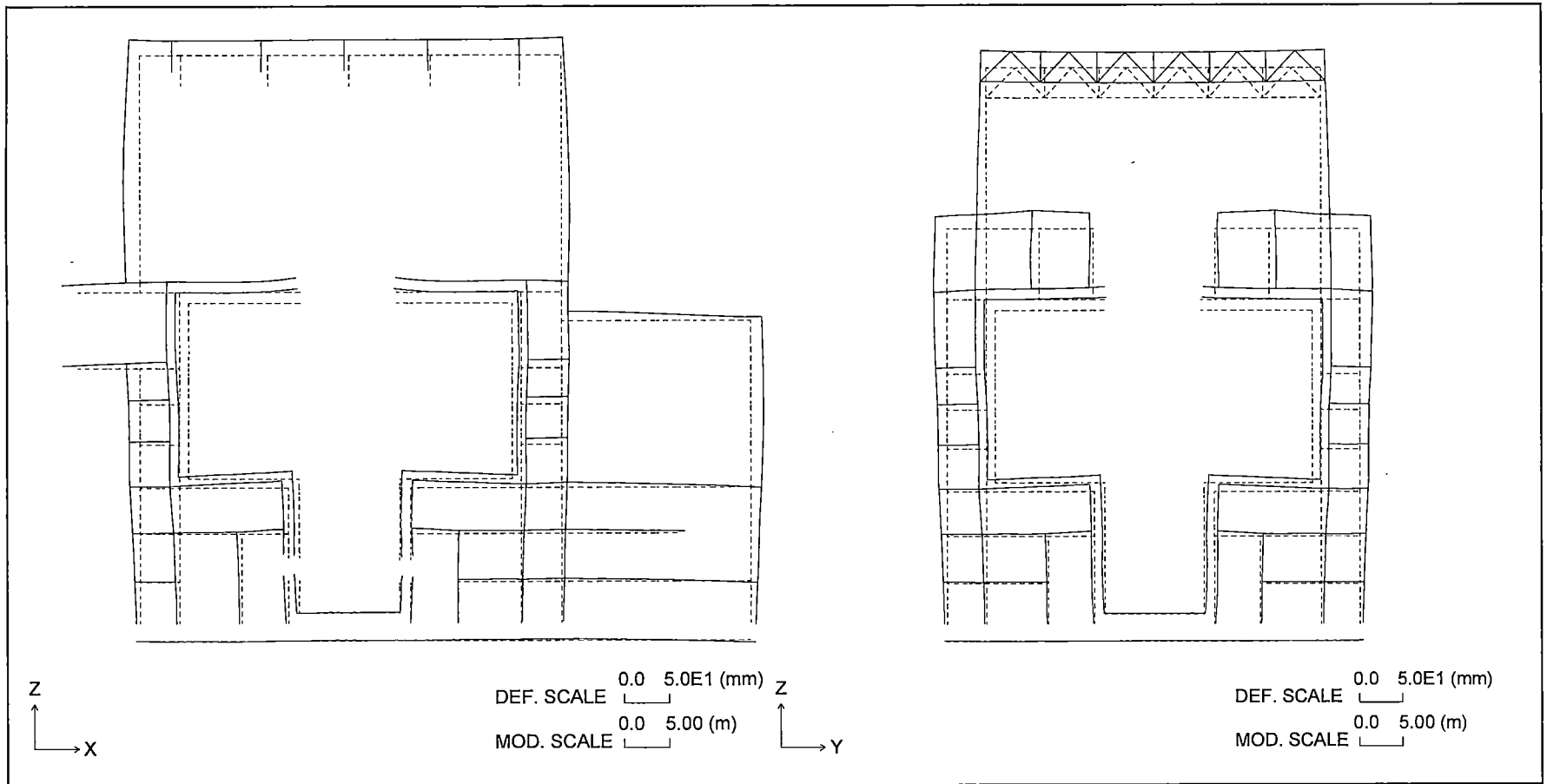


Figure 6.2.4-9 Section Deformation for Thermal Load (LOCA After 72 hr.: Summer)



HITACHI

WG3-U71-ERD-S-0004

SH NO. 457

REV. 0

of 538

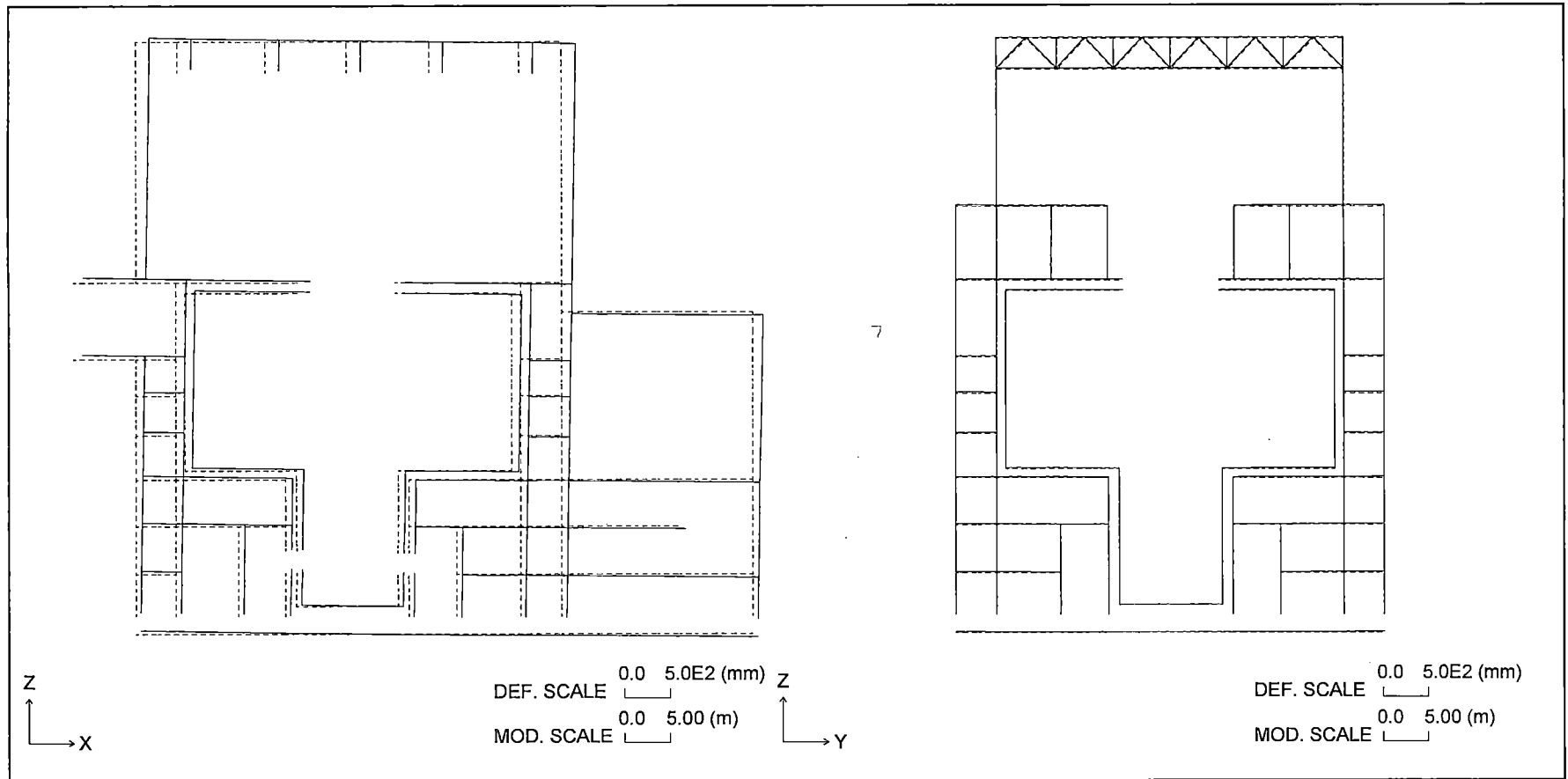


Figure 6.2.4-10 Section Deformation for Seismic Load (Horizontal: North to South)



HITACHI

WG3-U71-ERD-S-0004

SH NO. 458

REV. 0

of 538

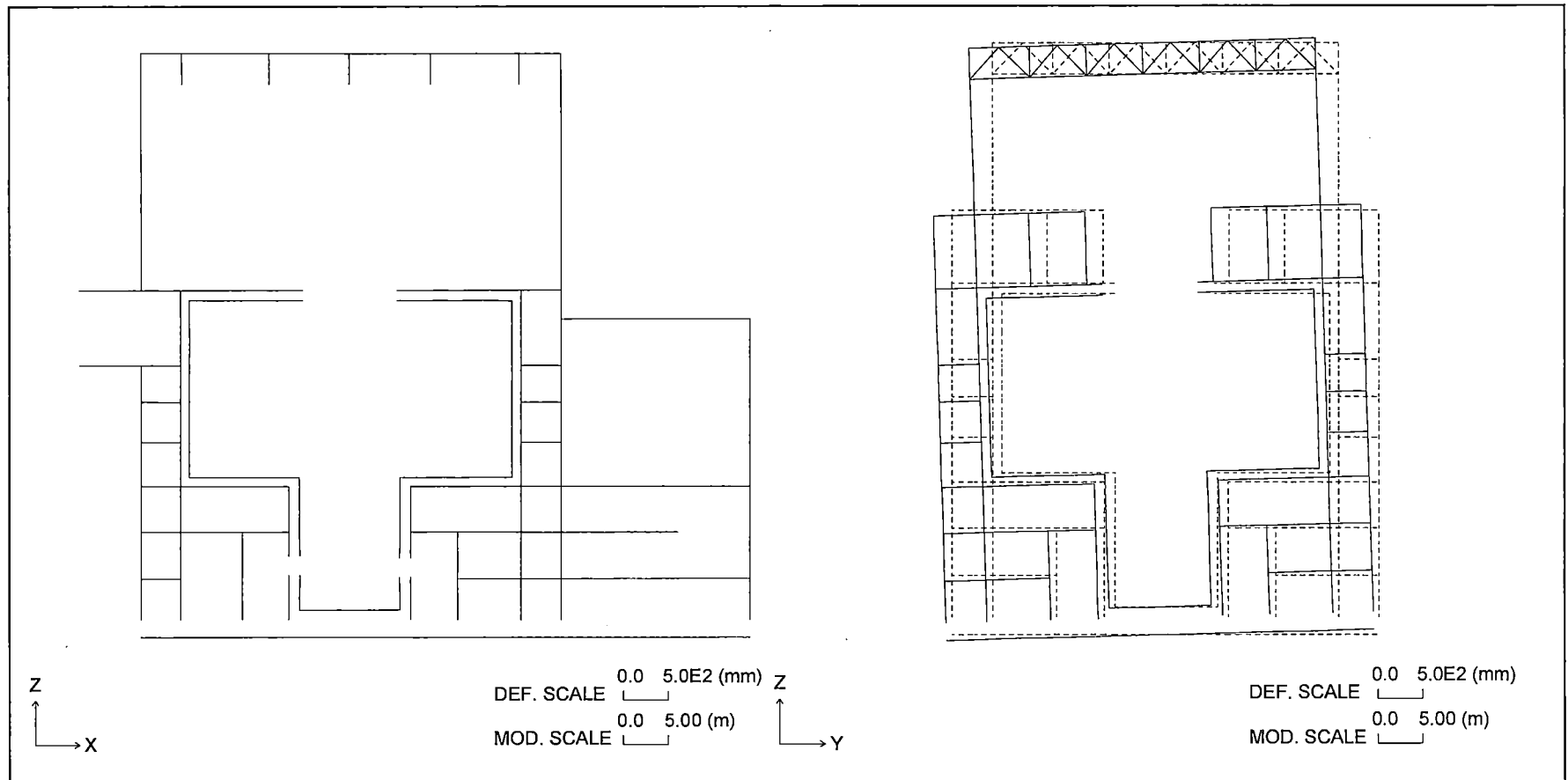


Figure 6.2.4-11 Section Deformation for Seismic Load (Horizontal: East to West)



HITACHI

WG3-U71-ERD-S-0004

SH NO. 459

REV. 0

of 538

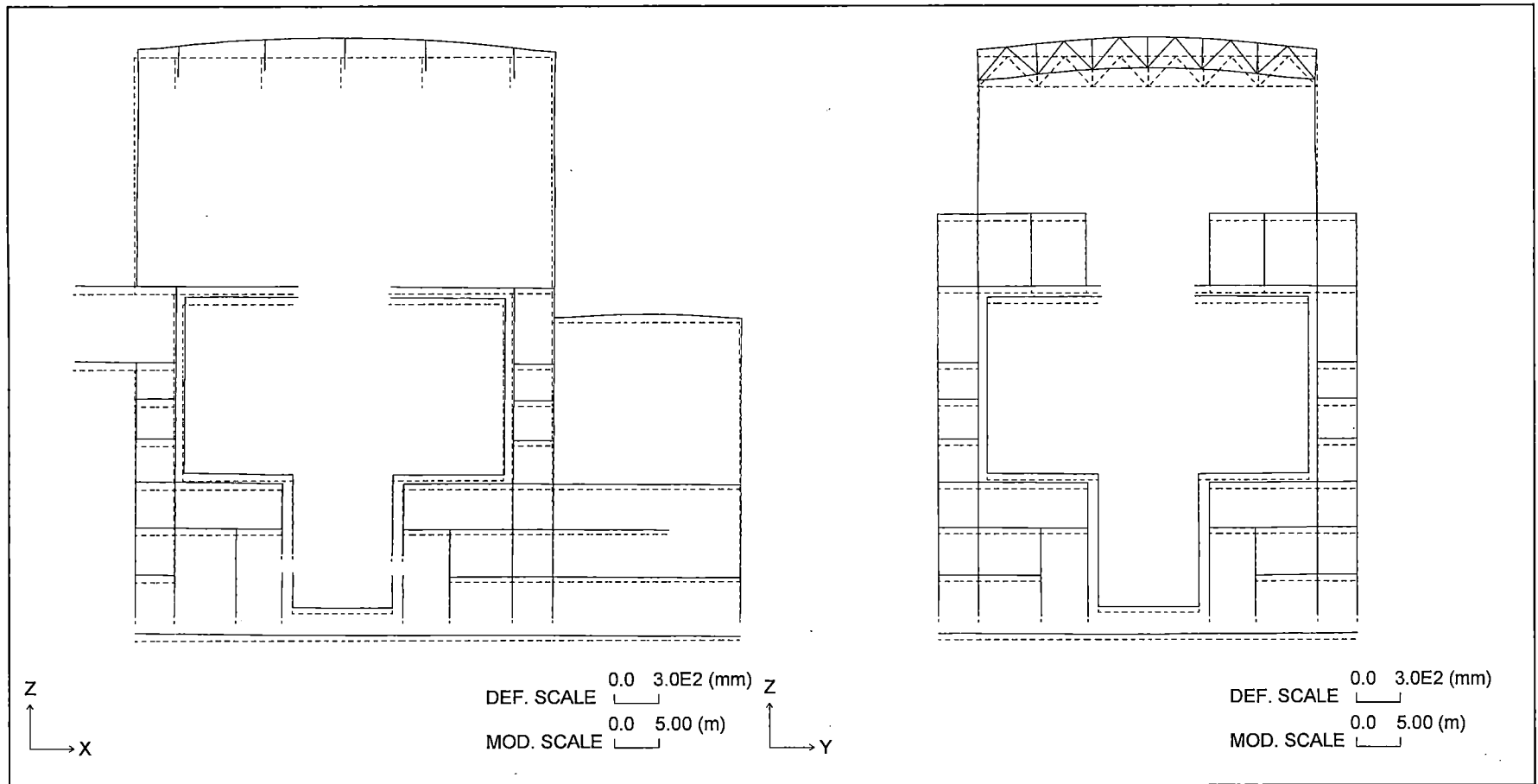


Figure 6.2.4-12 Section Deformation for Seismic Load (Vertical: Upward)

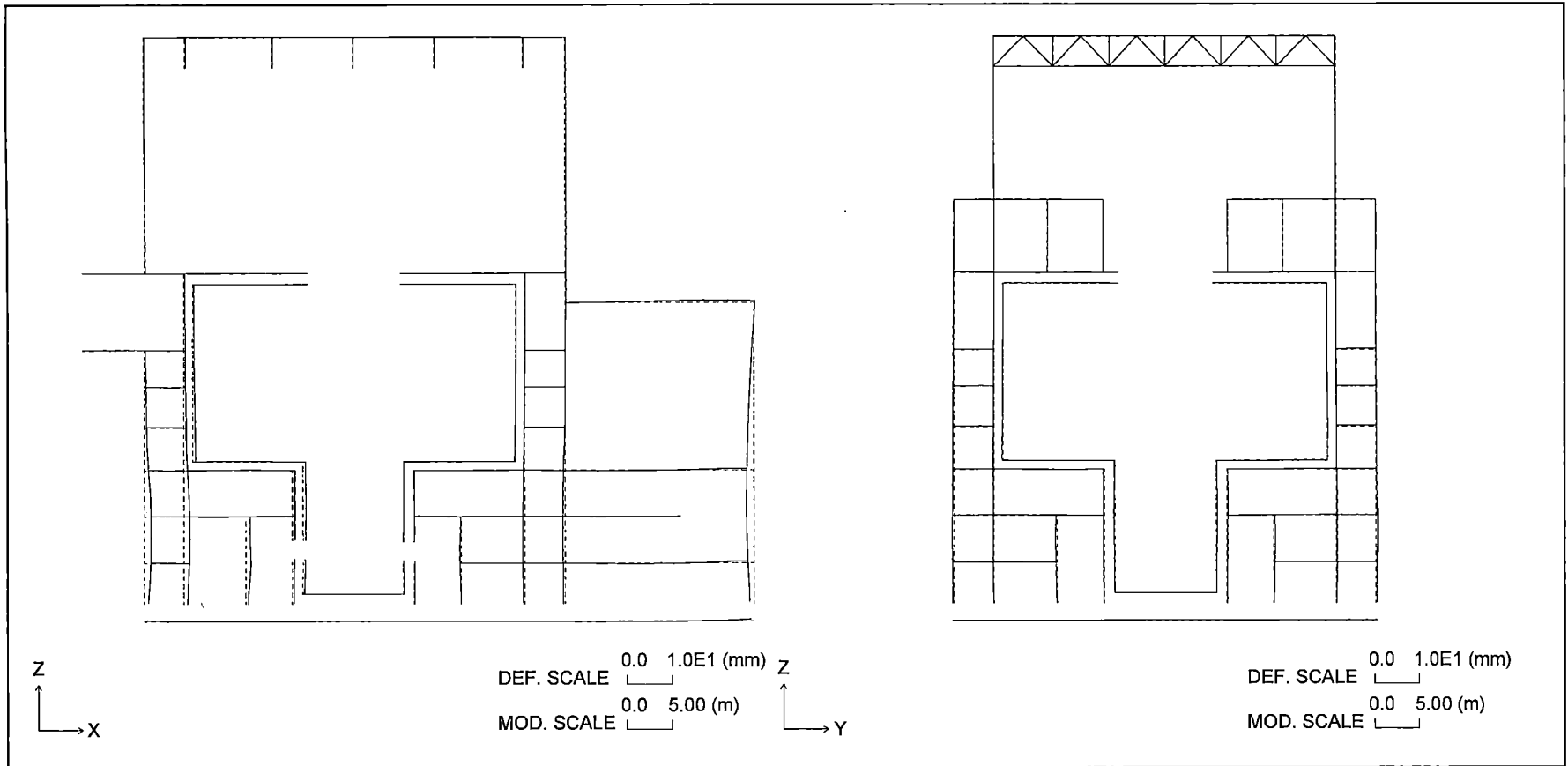


Figure 6.2.4-13 Section Deformation for Soil Pressure Due to an Earthquake (N-S)



HITACHI

WG3-U71-ERD-S-0004

SH NO. 461

REV. 0

of 538

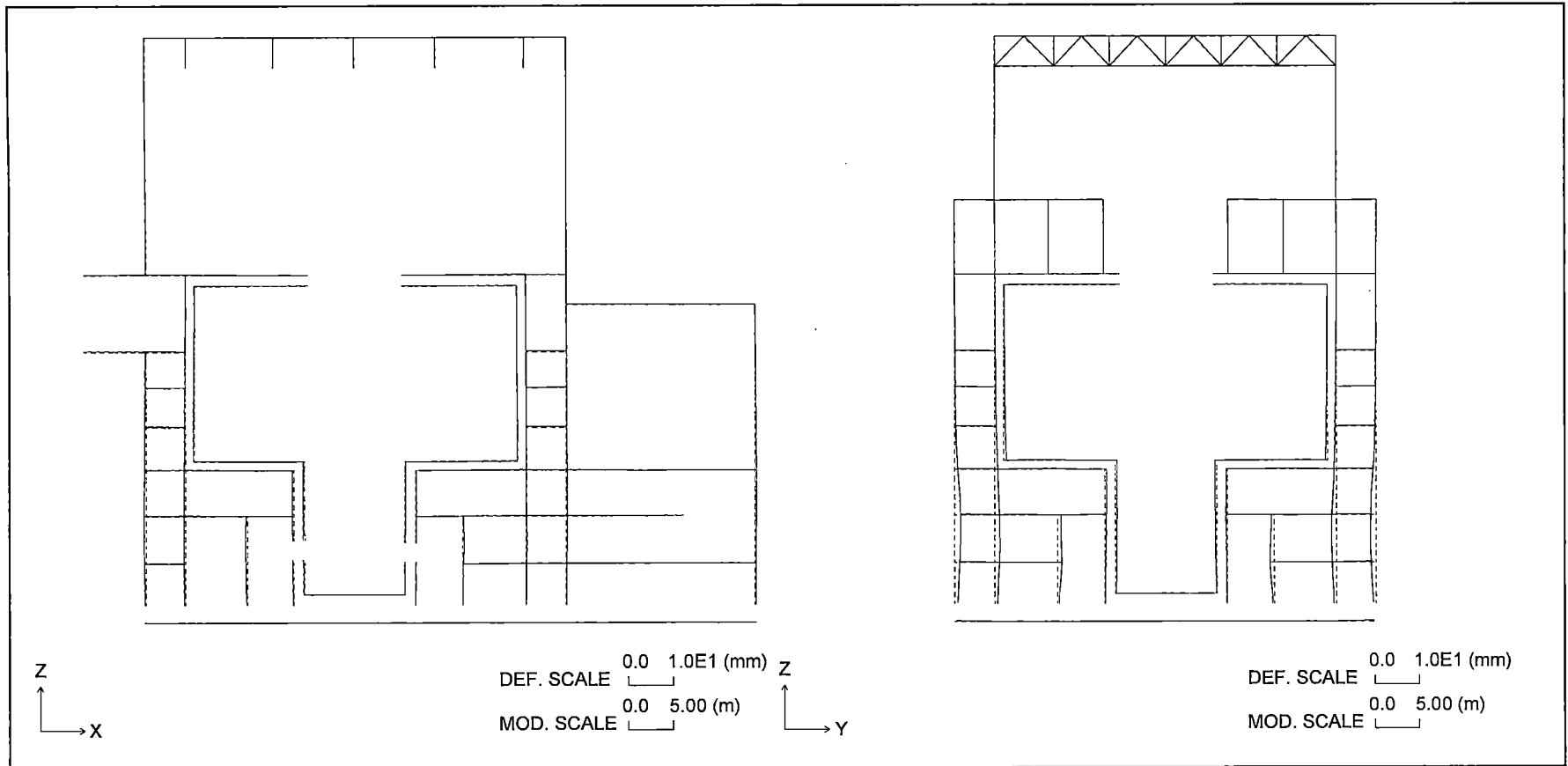


Figure 6.2.4-14 Section Deformation for Soil Pressure Due to an Earthquake (E-W)



HITACHI

WG3-U71-ERD-S-0004 SH NO. 462
REV. 0 of 538

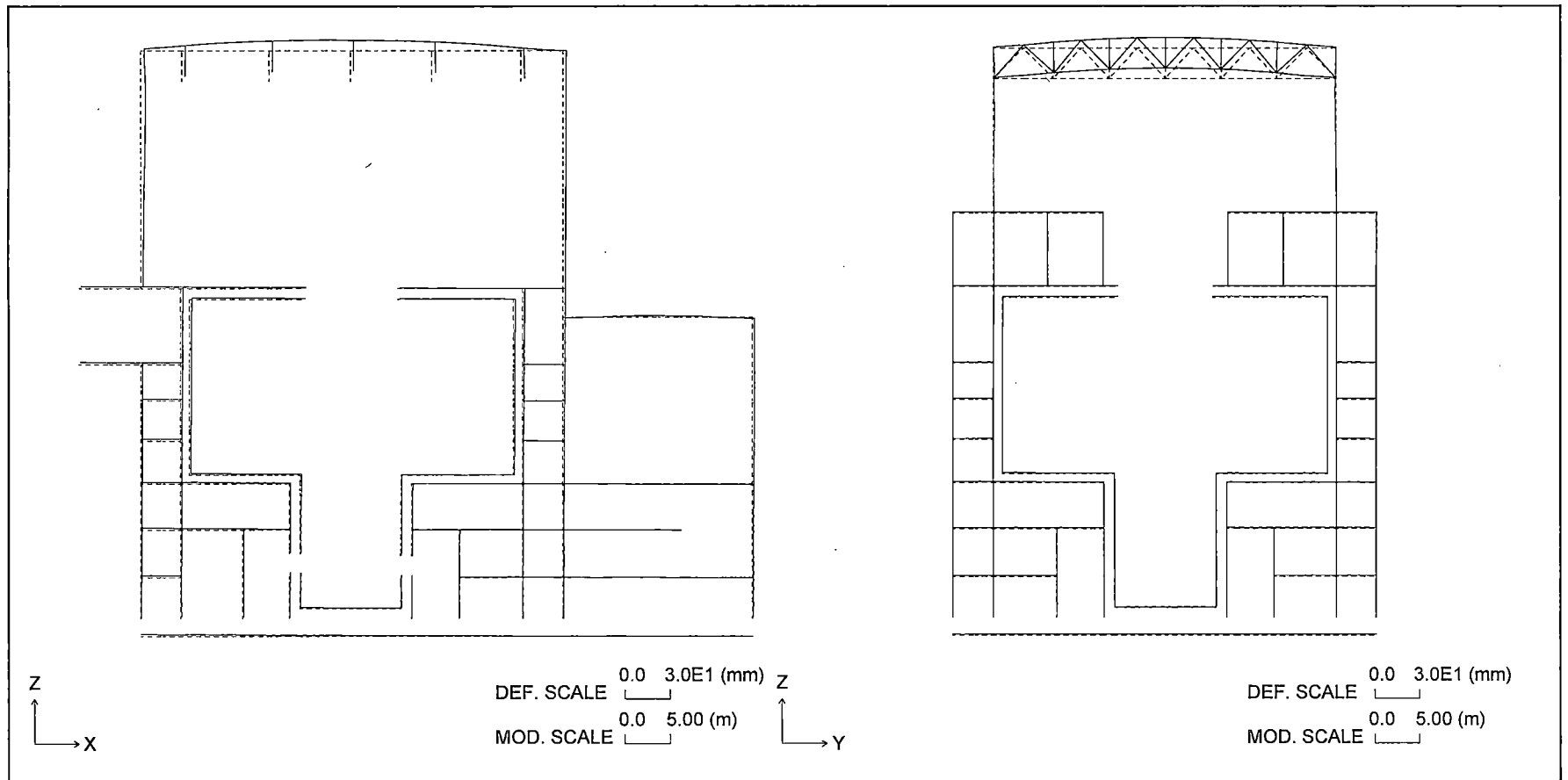


Figure 6.2.4-15 Section Deformation for Wind Load (North Wind)



HITACHI

WG3-U71-ERD-S-0004

SH NO. 463

REV. 0

of 538

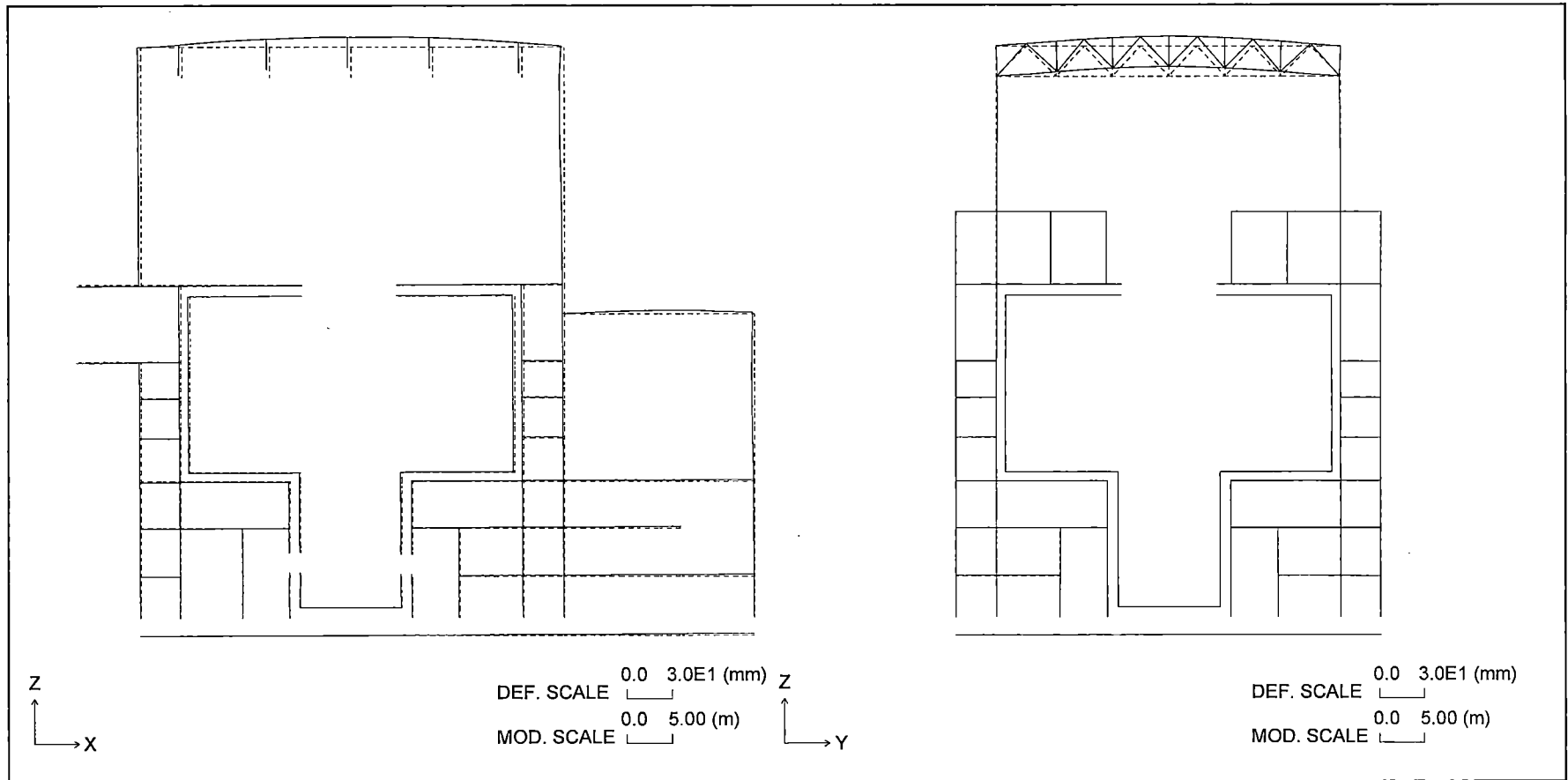


Figure 6.2.4-16 Section Deformation for Wind Load (South Wind)

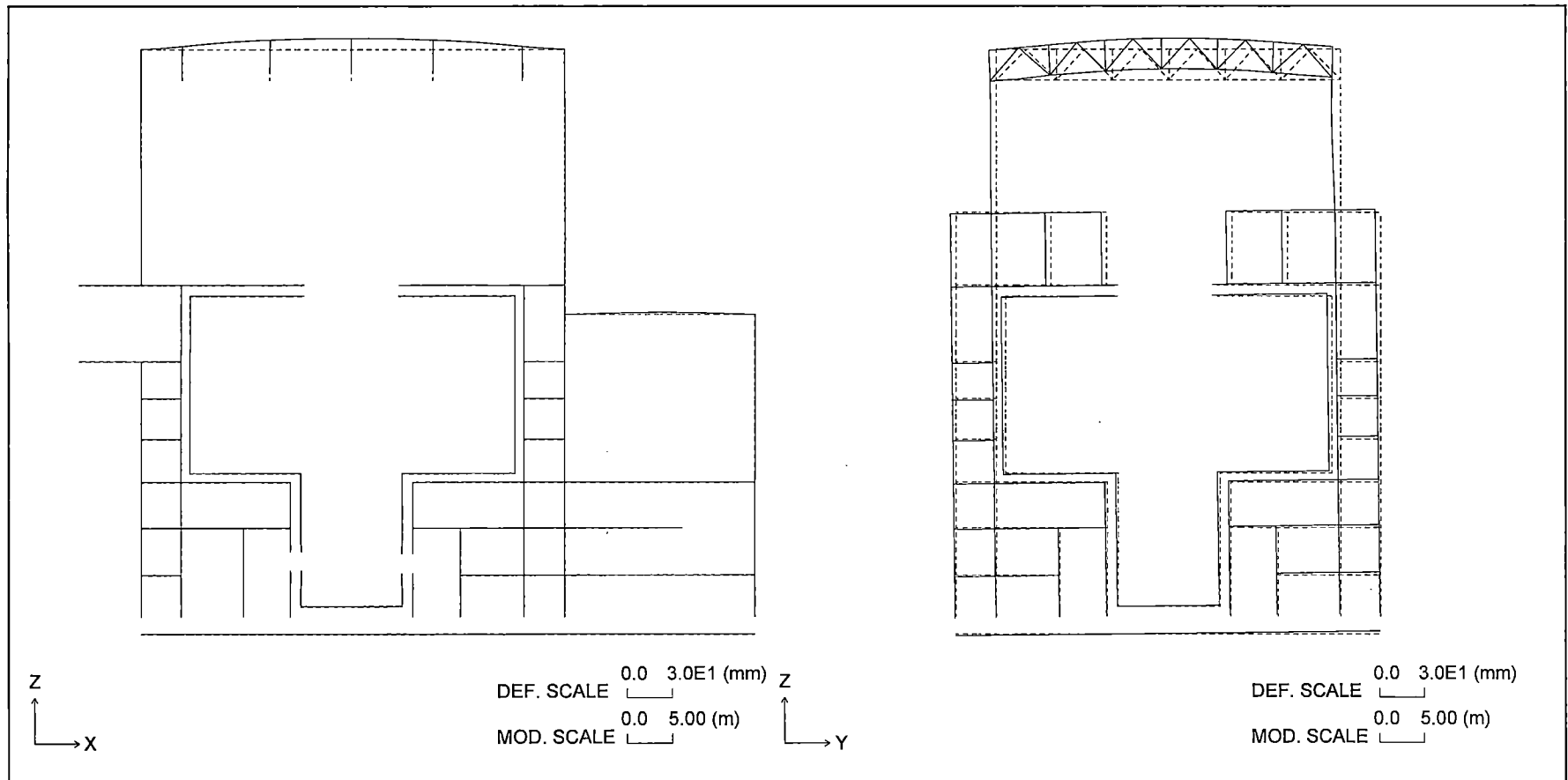


Figure 6.2.4-17 Section Deformation for Wind Load (East Wind)



HITACHI

WG3-U71-ERD-S-0004 SH NO. 465
REV. 0 of 538

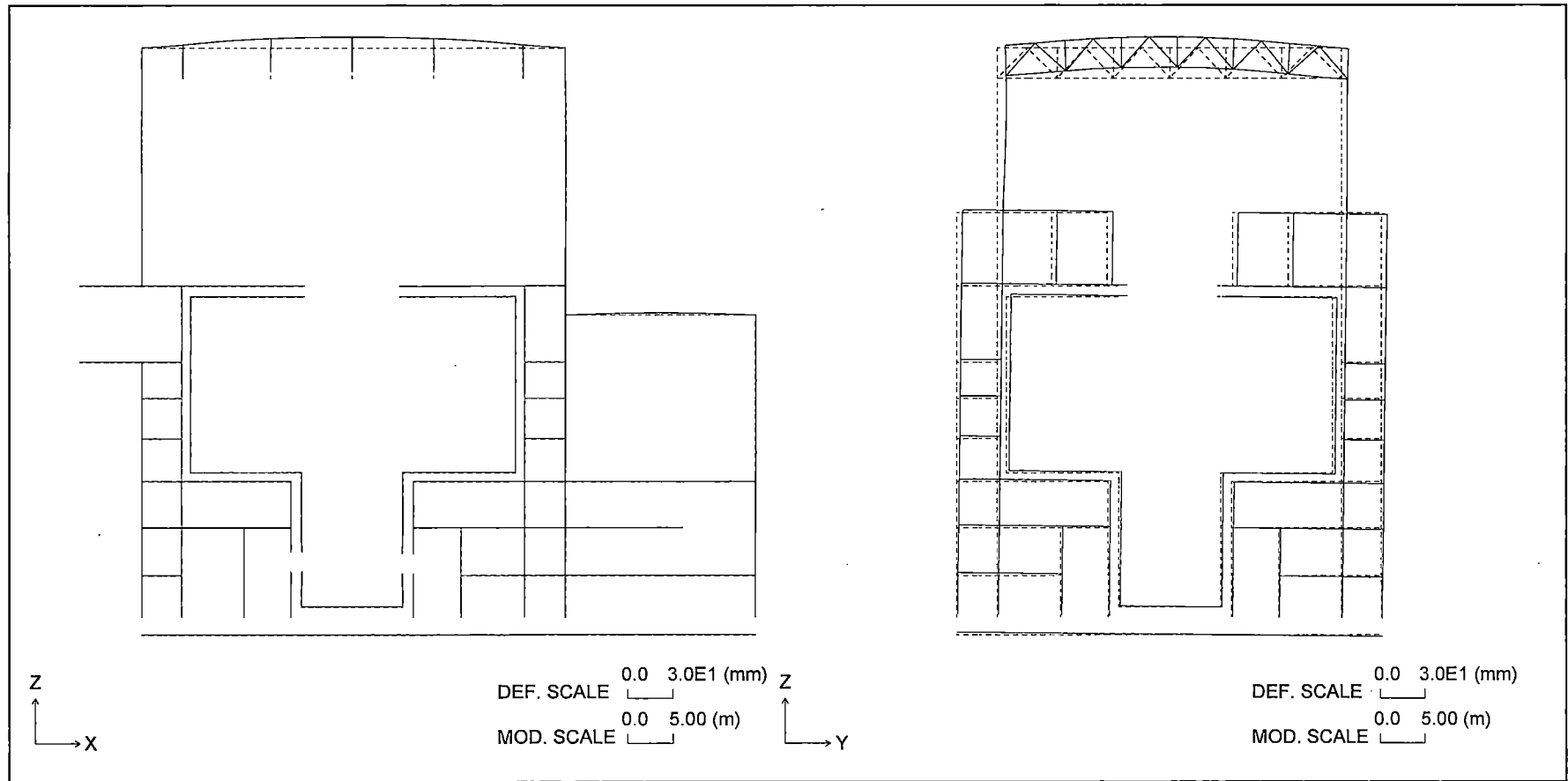


Figure 6.2.4-18 Section Deformation for Wind Load (West Wind)

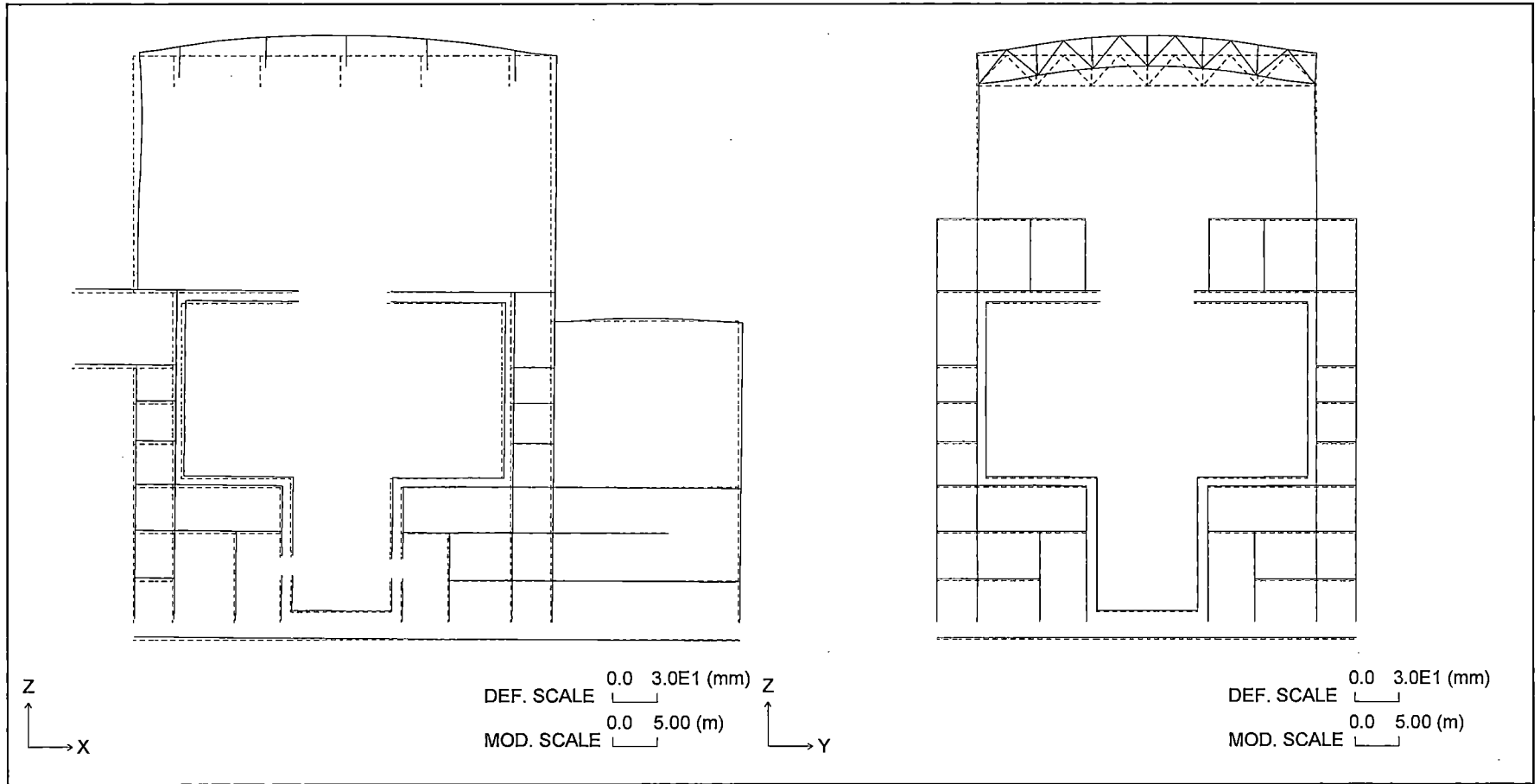


Figure 6.2.4-19 Section Deformation for Tornado Load (North Wind)



HITACHI

WG3-U71-ERD-S-0004

SH NO. 467

REV. 0

of 538

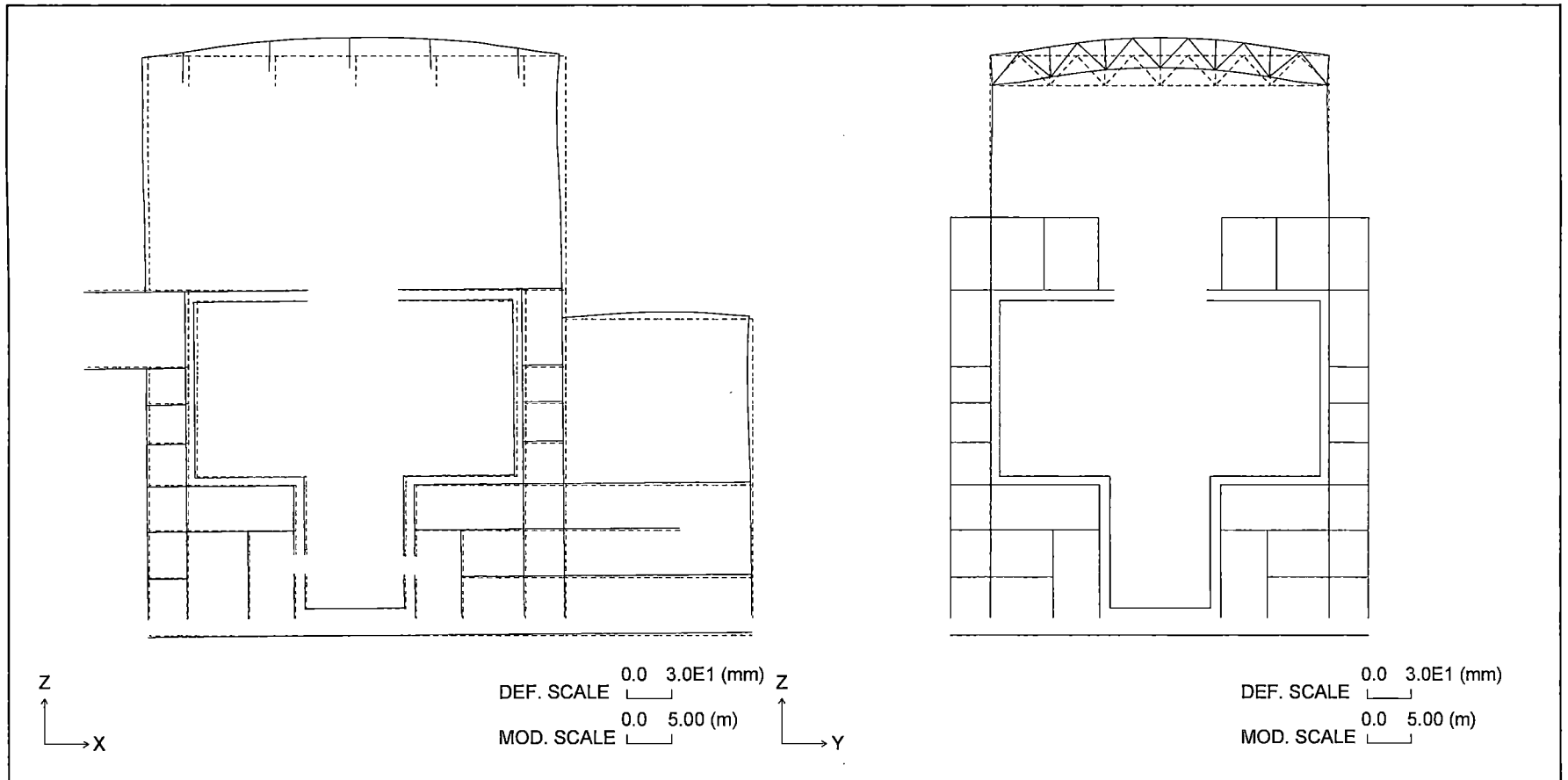


Figure 6.2.4-20 Section Deformation for Tornado Load (South Wind)



HITACHI

WG3-U71-ERD-S-0004

SH NO. 468

REV. 0

of 538

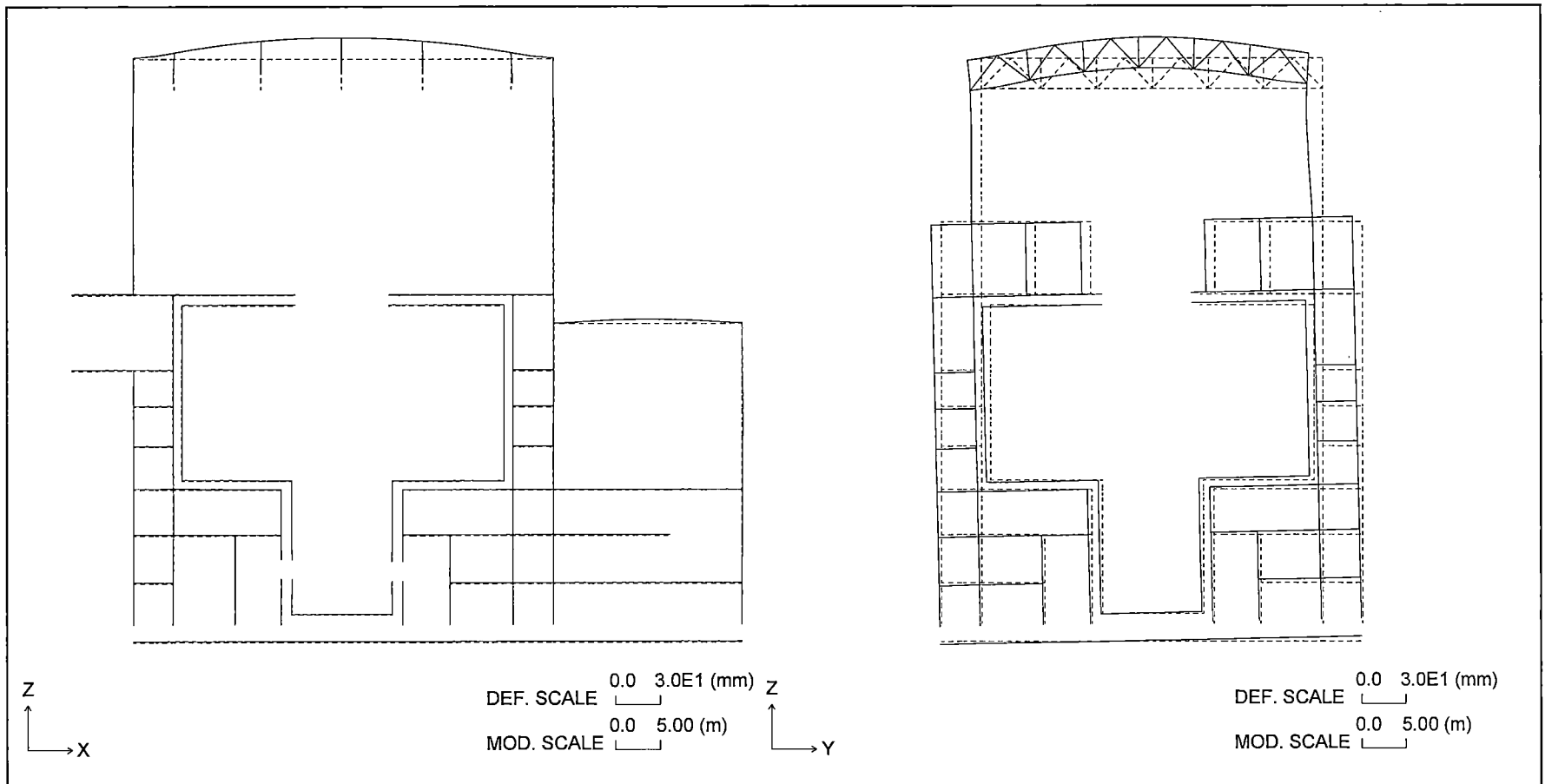


Figure 6.2.4-21 Section Deformation for Tornado Load (East Wind)



HITACHI

WG3-U71-ERD-S-0004 SH NO. 469
REV. 0 of 538

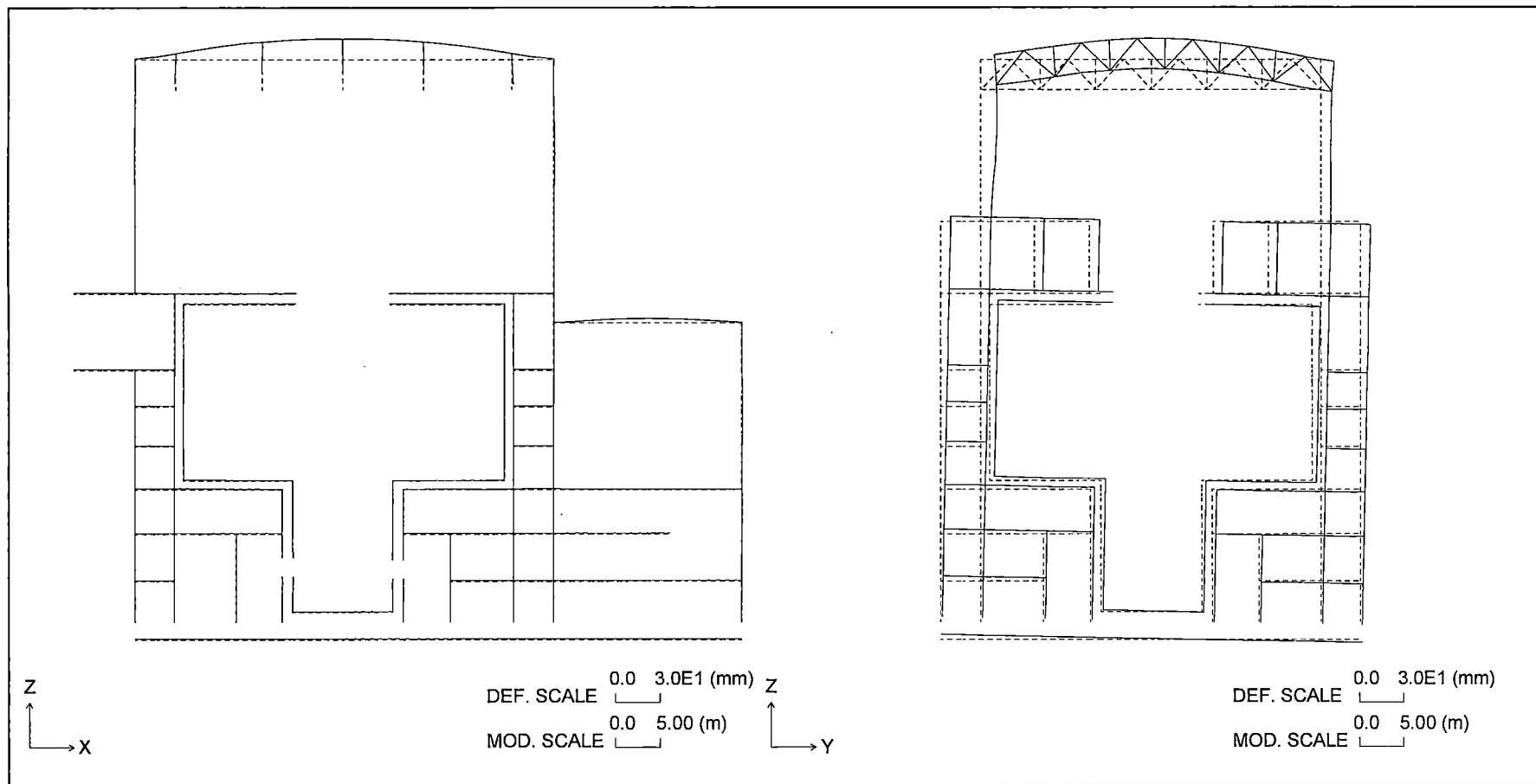


Figure 6.2.4-22 Section Deformation for Tornado Load (West Wind)



HITACHI

WG3-U71-ERD-S-0004

SH NO. 470

REV. 0

of 538

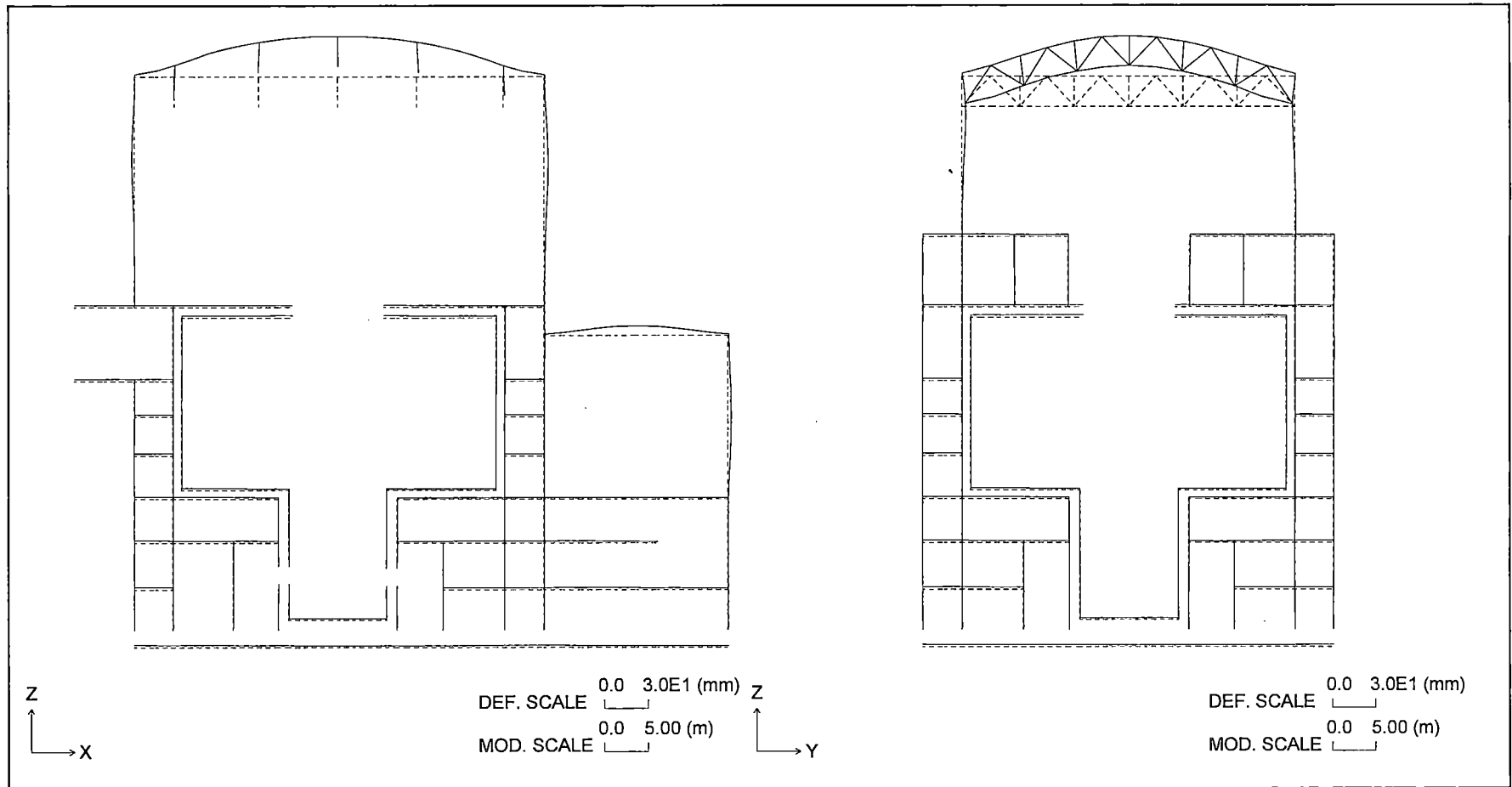


Figure 6.2.4-23 Section Deformation for Tornado Load (Differential Pressure)



HITACHI

WG3-U71-ERD-S-0004

SH NO. 471

REV. 0

of 538

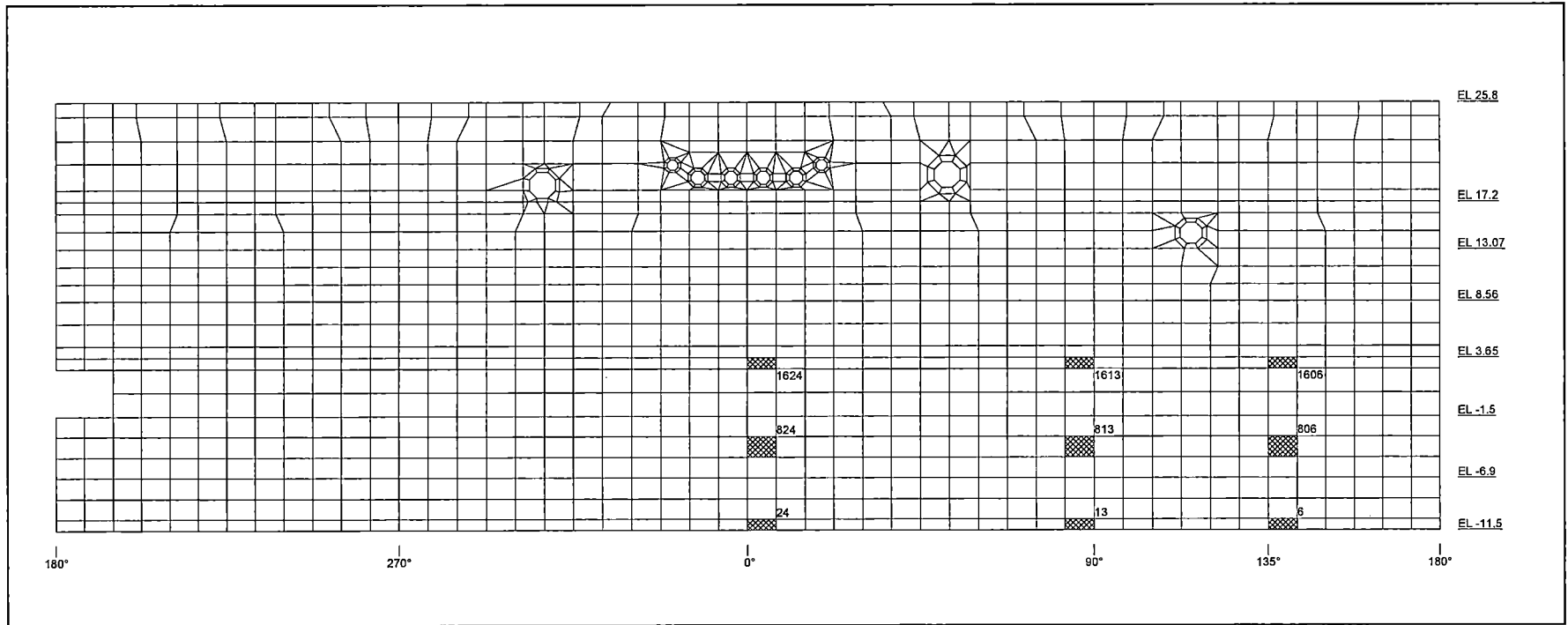


Figure 6.2.4-24 Elements Selected for Tabulation (Wall below RCCV)



HITACHI

WG3-U71-ERD-S-0004 SH NO. 472
REV. 0 of 538

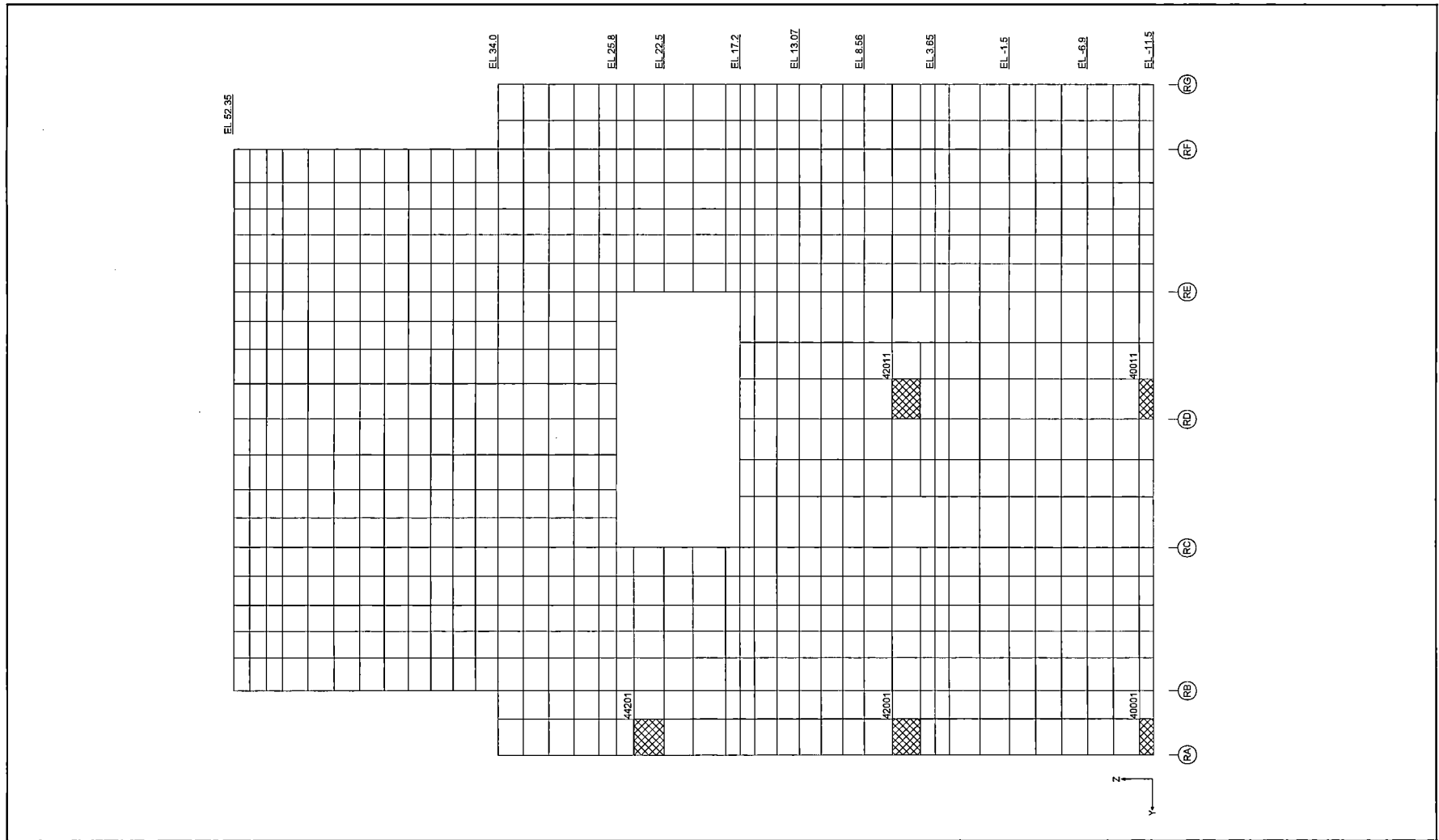


Figure 6.2.4-25 Elements Selected for Tabulation (External Wall R1)



HITACHI

WG3-U71-ERD-S-0004 SH NO. 473
REV. 0 of 538

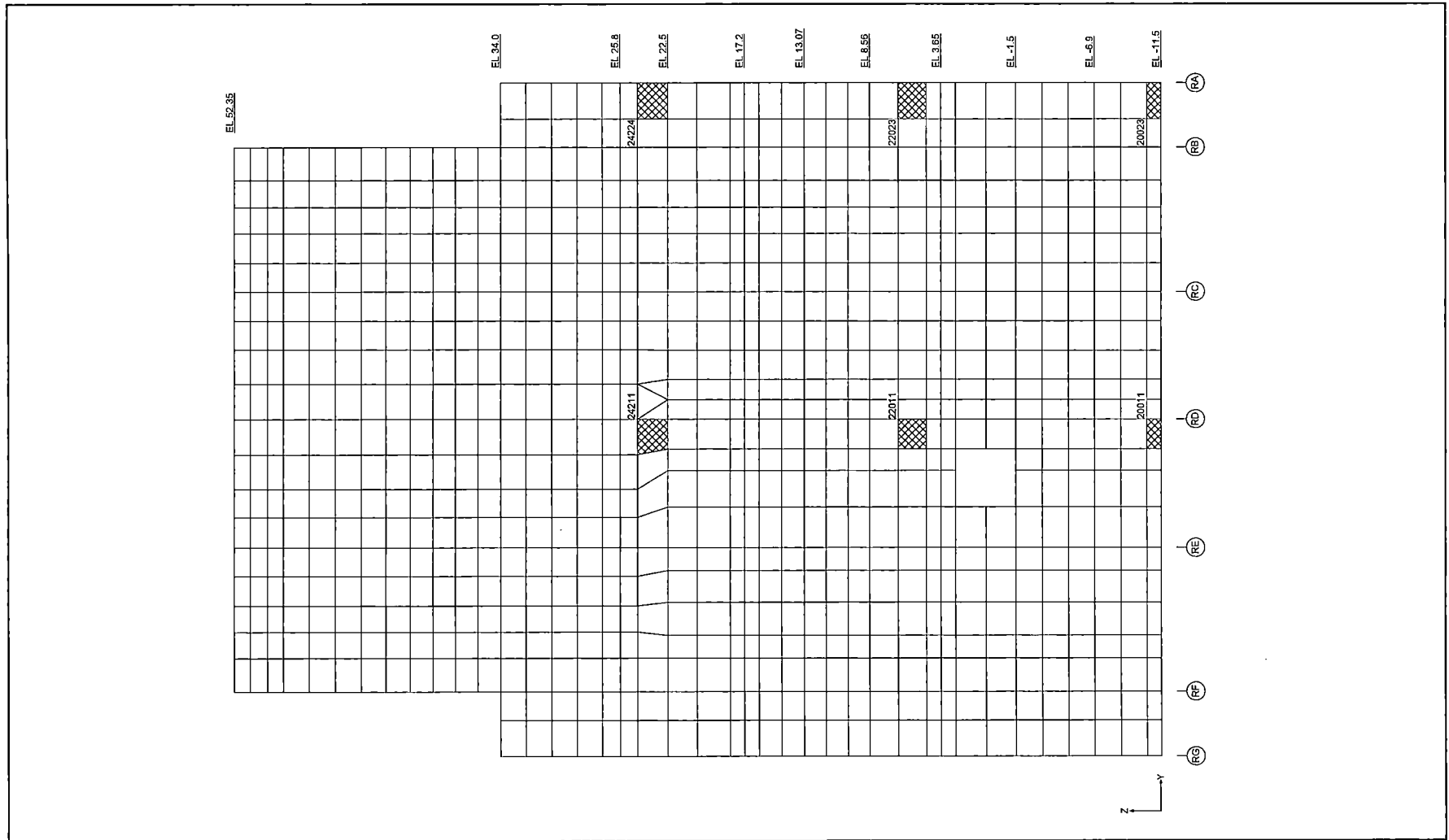


Figure 6.2.4-26 Elements Selected for Tabulation (External Wall R7/F1)

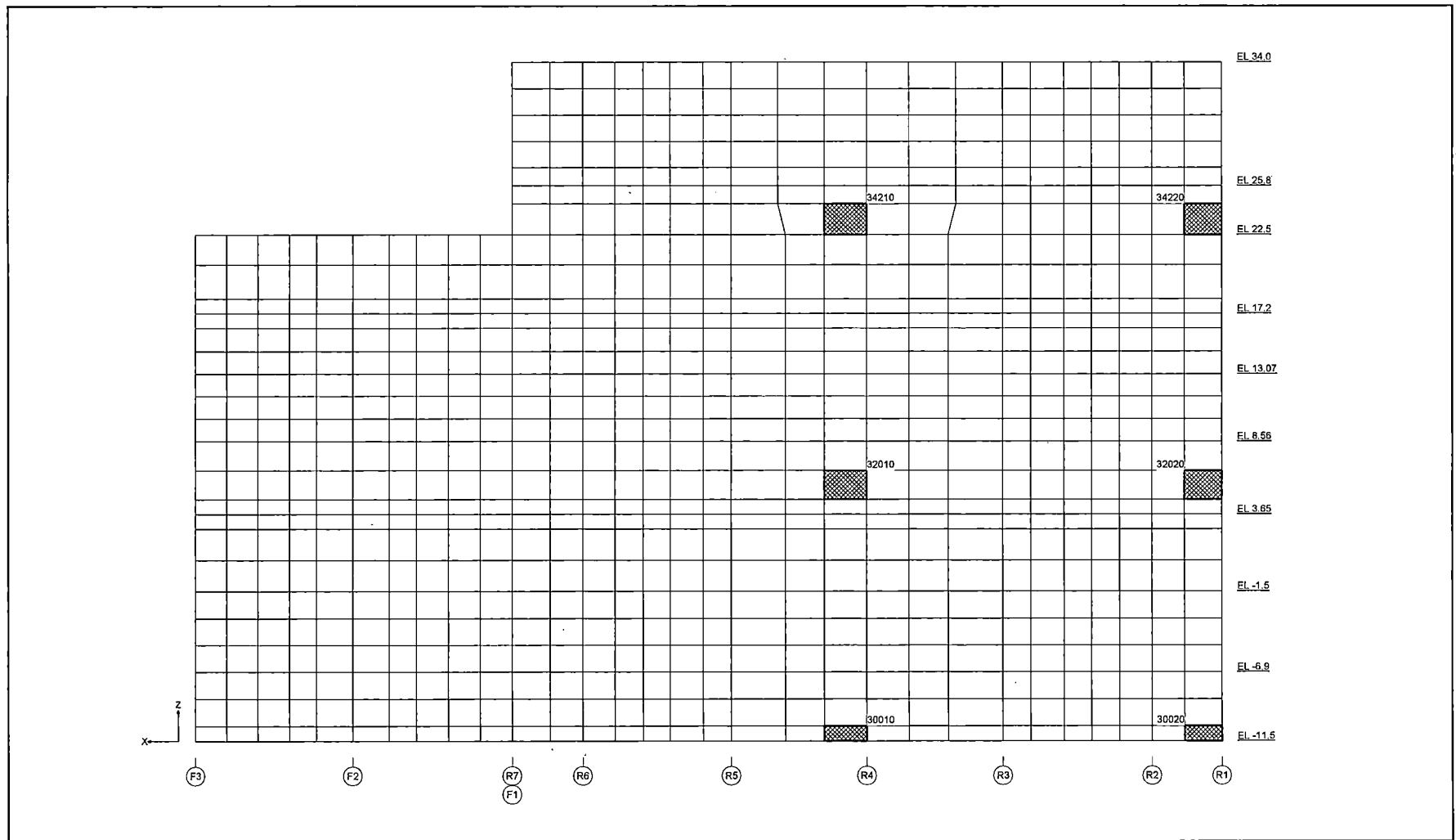


Figure 6.2.4-27 Elements Selected for Tabulation (External Wall RA FA)

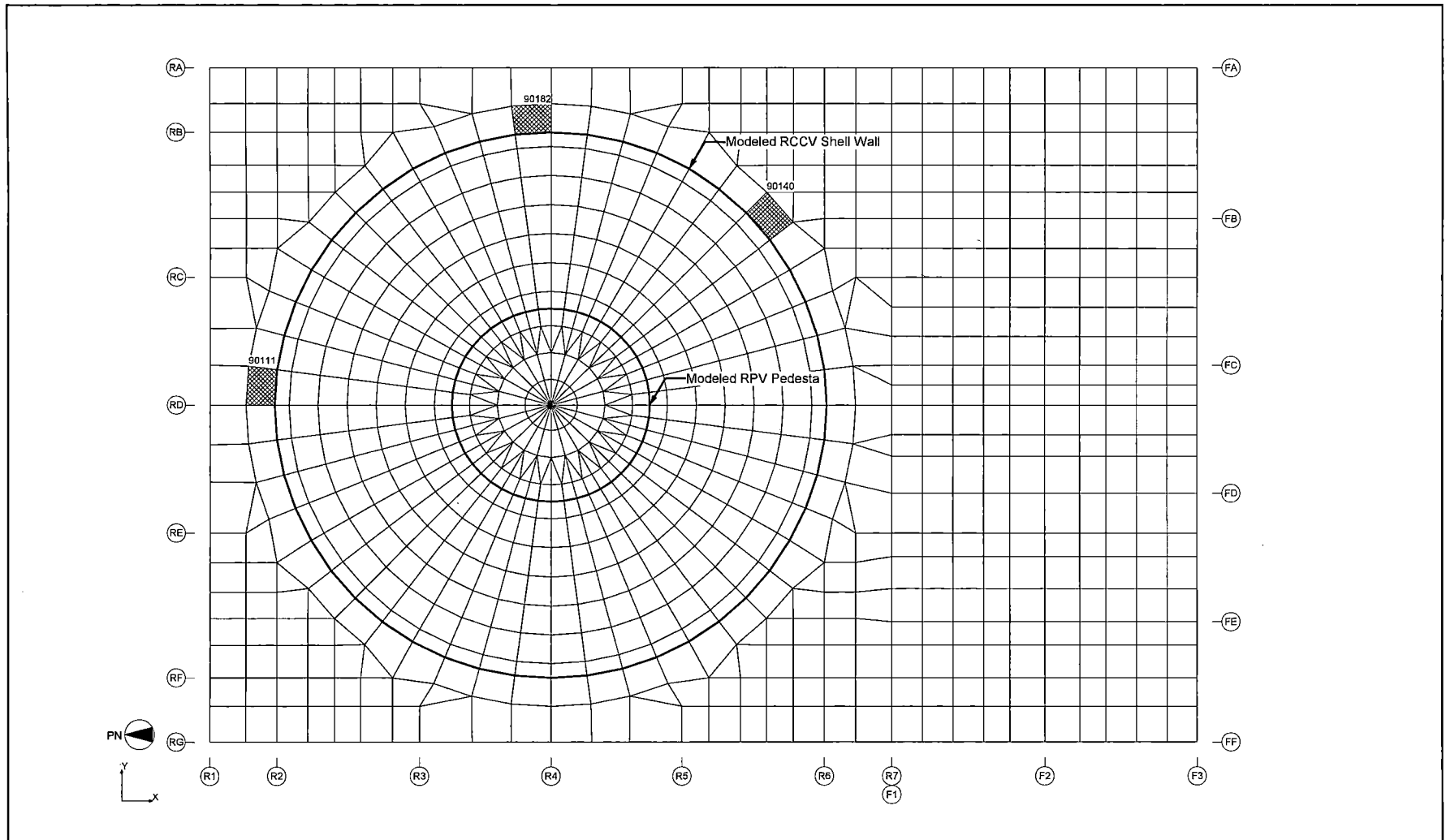


Figure 6.2.4-28 Elements Selected for Tabulation (Basemat)

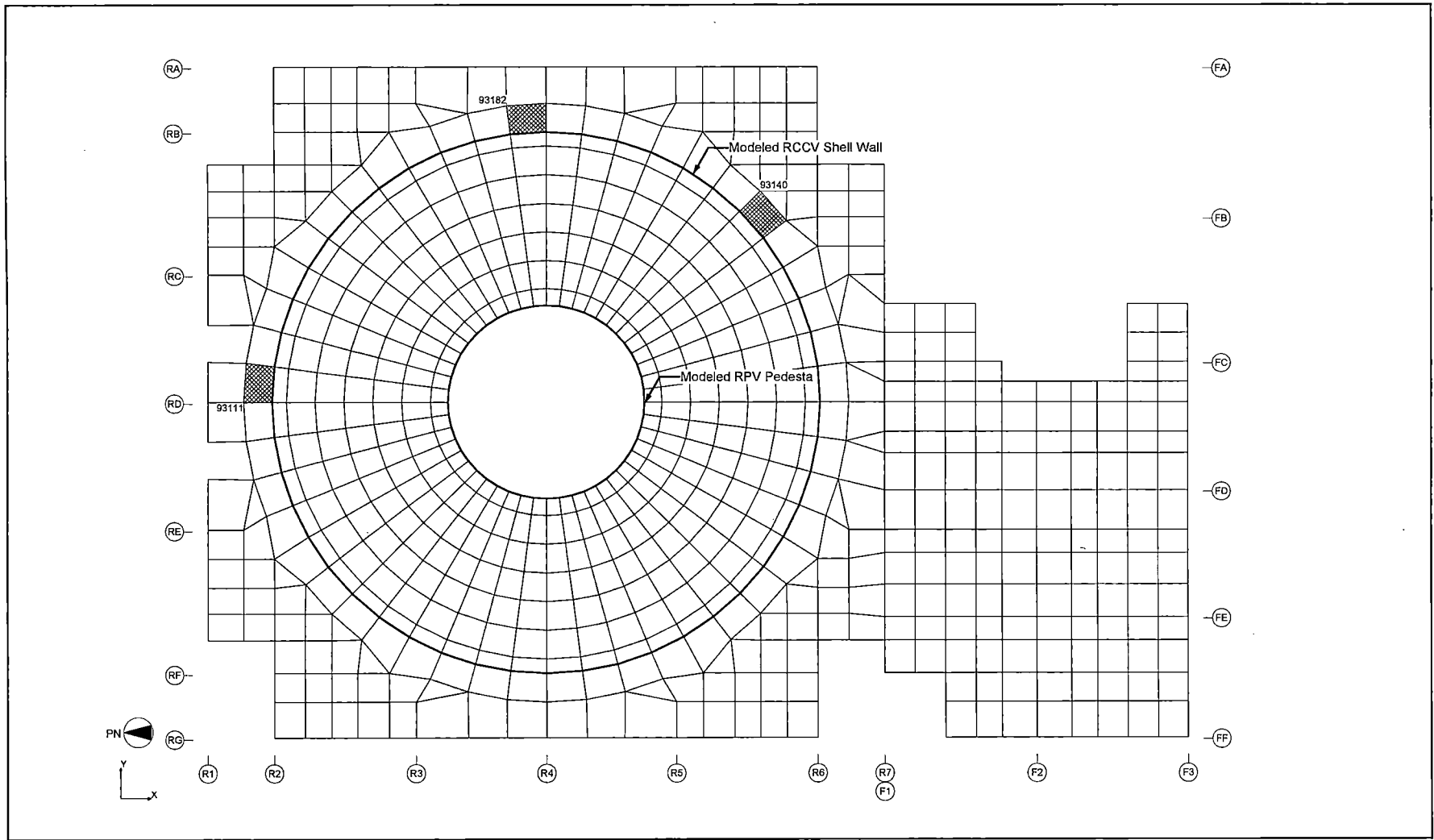


Figure 6.2.4-29 Elements Selected for Tabulation (Slab at EL 4,650)



HITACHI

WG3-U71-ERD-S-0004

SH NO. 477

REV. 0

of 538

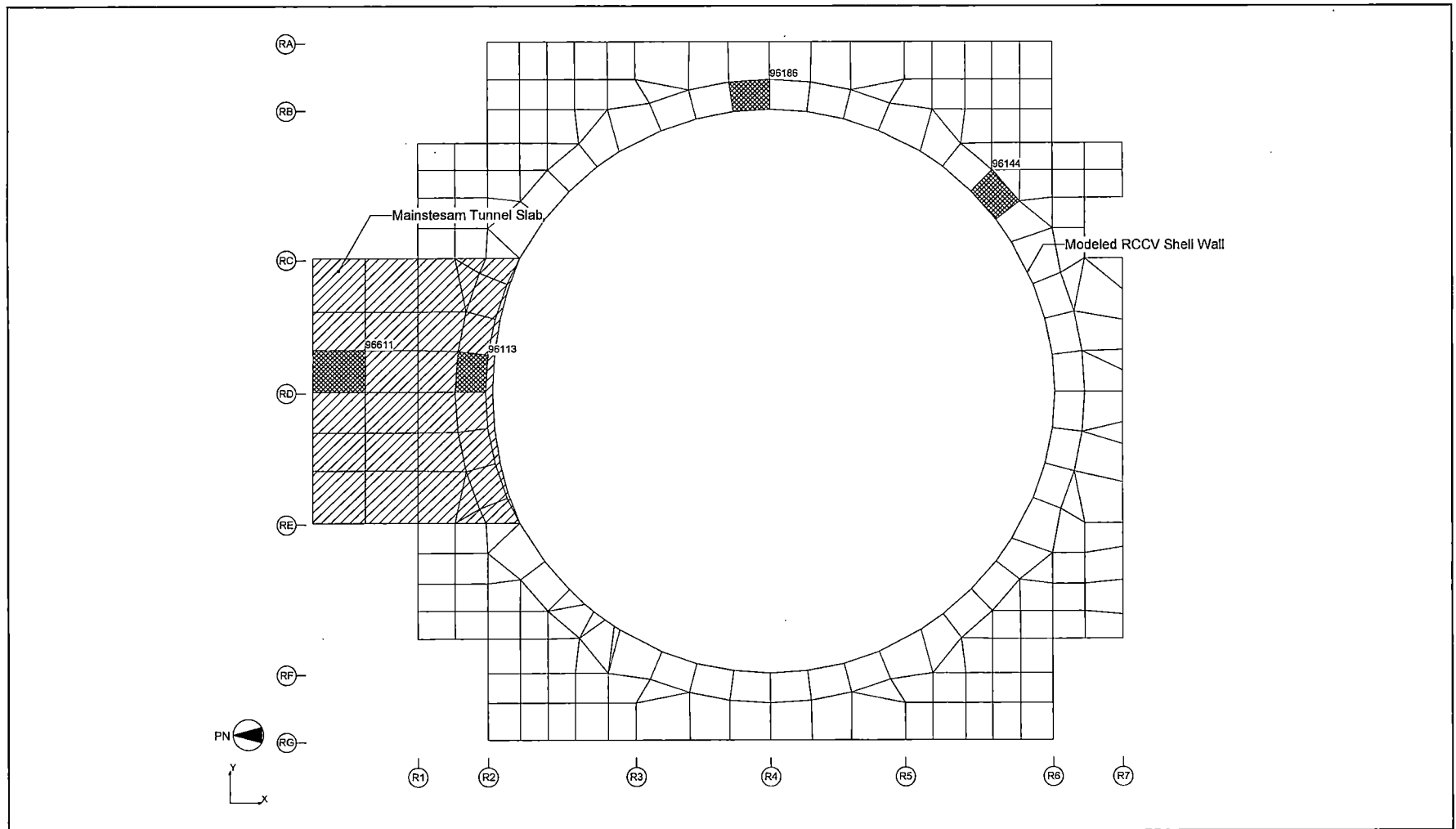


Figure 6.2.4-30 Elements Selected for Tabulation (Slab at EL 17,500)

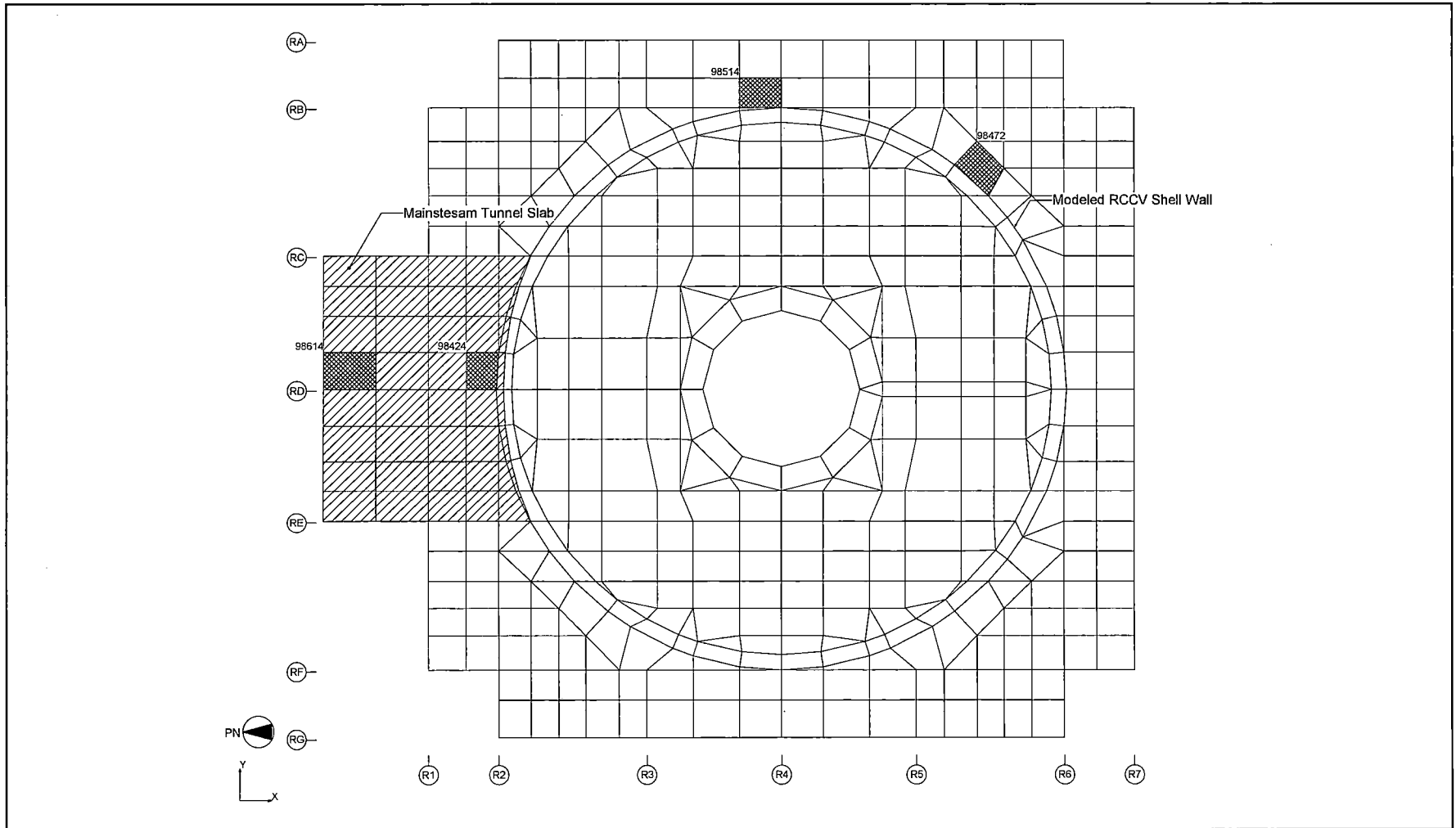


Figure 6.2.4-31 Elements Selected for Tabulation (Slab at EL 27,000)

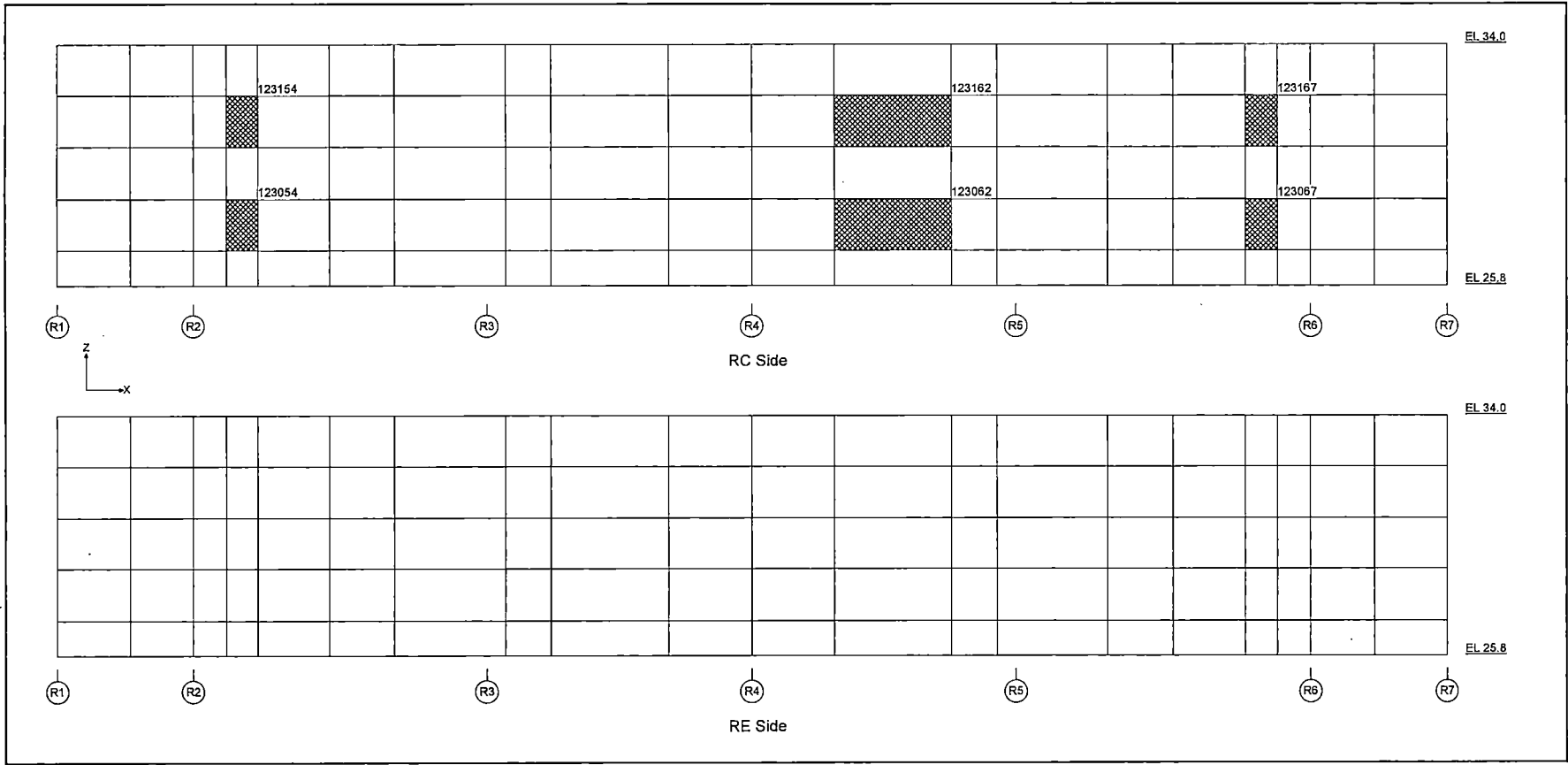


Figure 6.2.4-32 Elements Selected for Tabulation (Pool Girder)



HITACHI

WG3-U71-ERD-S-0004 SH NO. 480
REV. 0 of 538

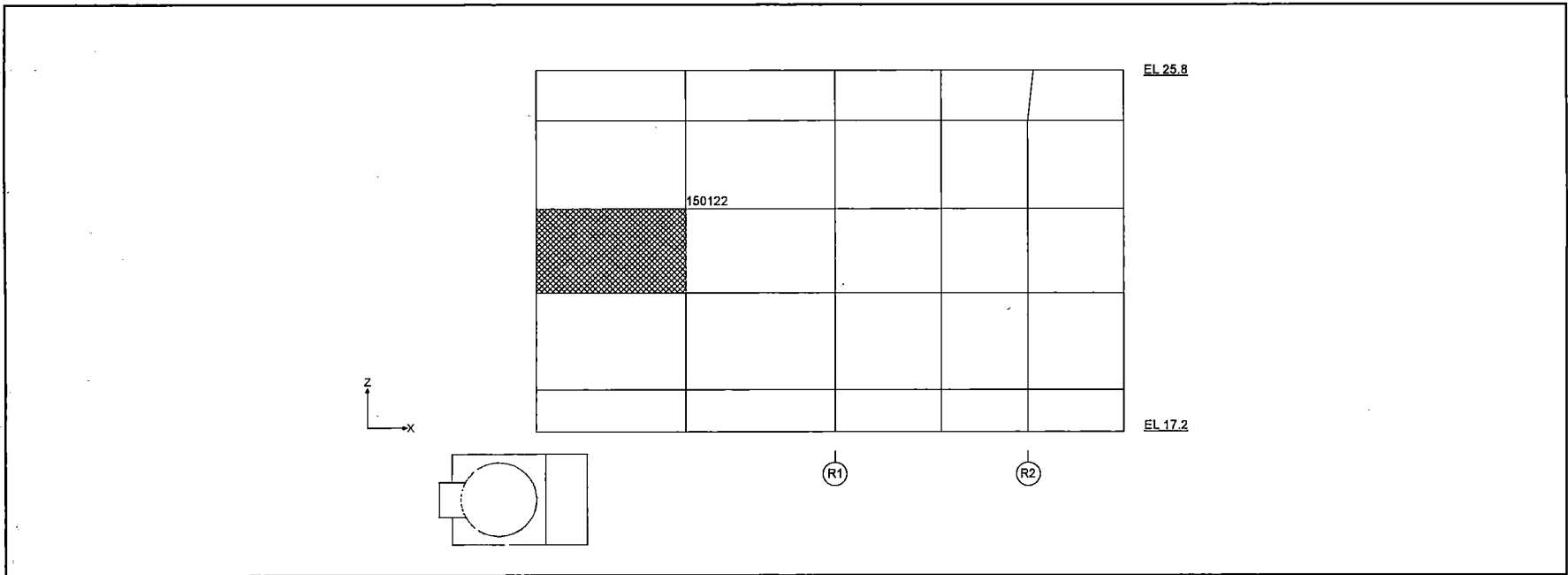


Figure 6.2.4-33 Elements Selected for Tabulation (MS Tunnel Wall)



HITACHI

WG3-U71-ERD-S-0004 SH NO. 481
REV. 0 of 538

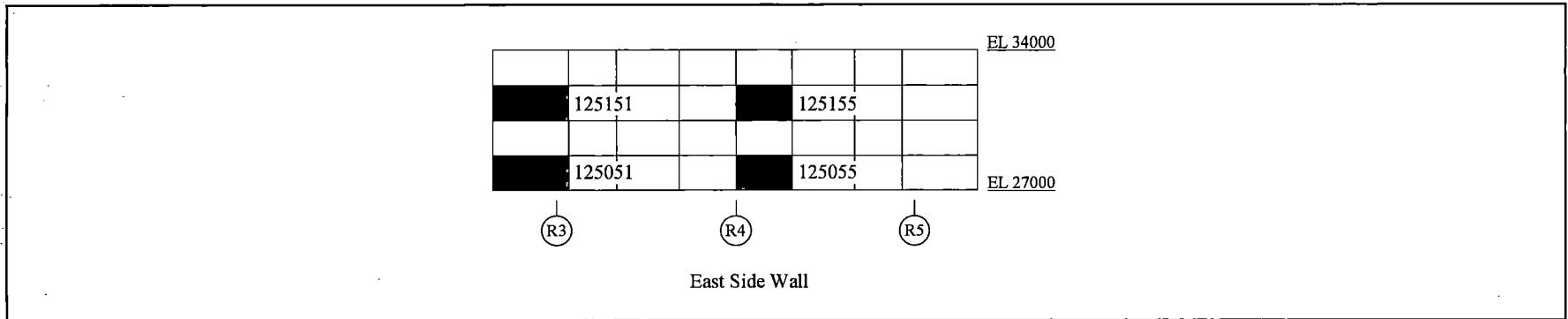
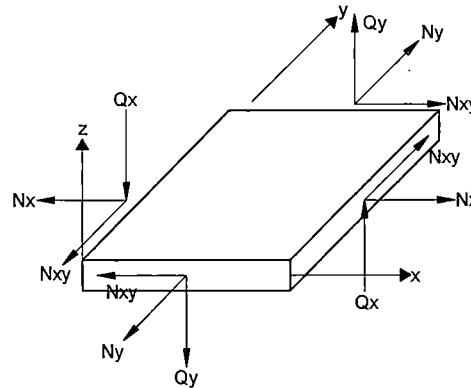
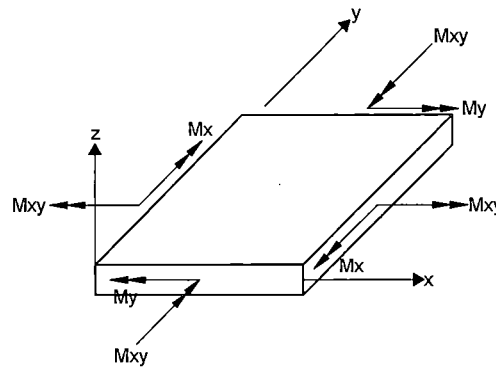


Figure 6.2.4-34 Elements Selected for Evaluation (IC/PCCS Pool in NS Direction)



Membrane and Shear Forces



Moments

Definition of Element Coordinate System

Structure	x	y	z
RCCV Wall RPV Pedestal External Wall	horizontal	vertical	outward
Wall in N-S Direction	horizontal	vertical	toward West
Wall in E-W Direction	horizontal	vertical	toward South
Foundation Mat Floor Slab Top Slab	toward South	toward West	downward
Suppression Pool Slab	radial	circumferential	downward

Figure 6.2.4-35 Force and Moment in Shell Element

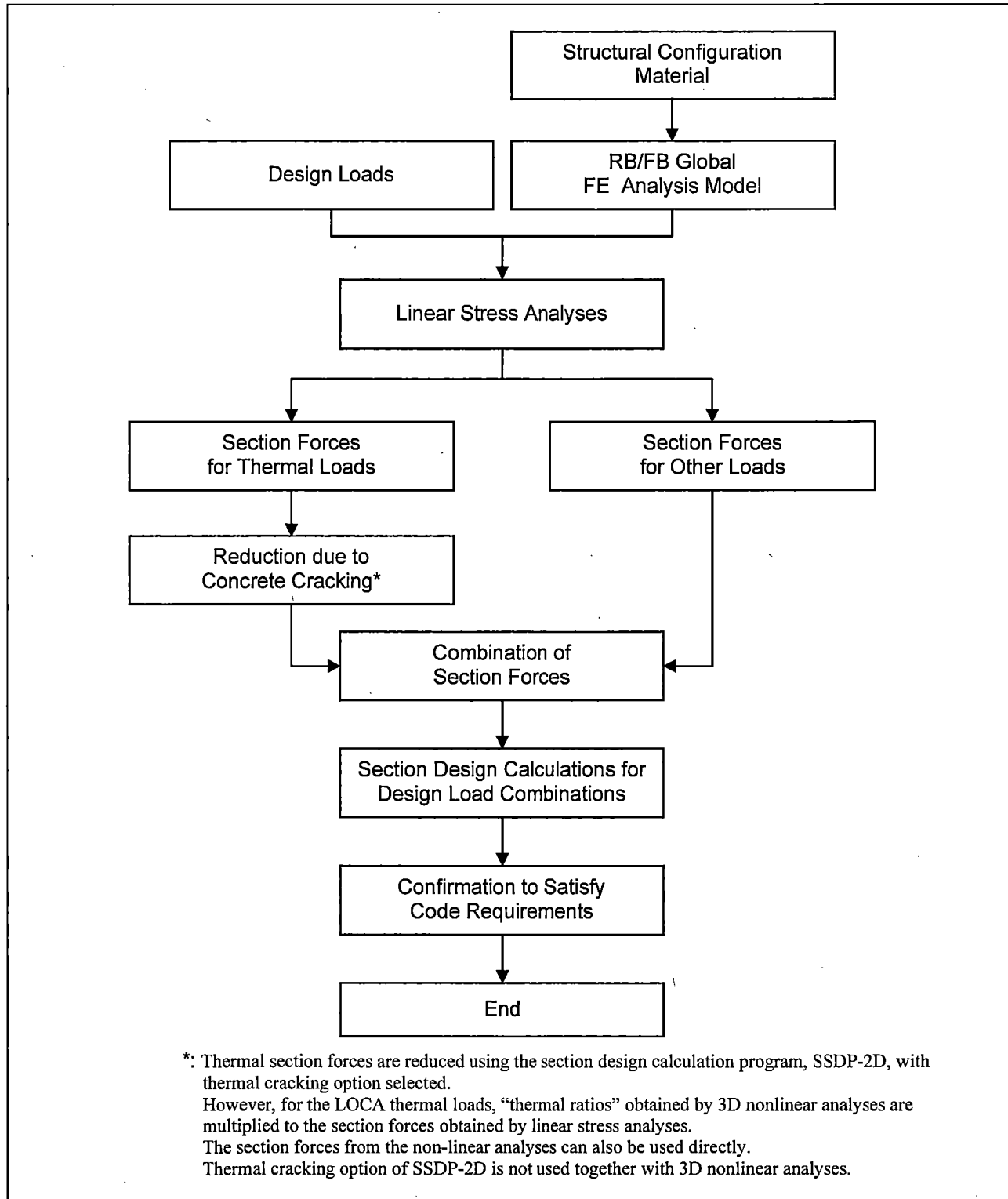


Figure 6.4.1-1 Flow Chart of Design for Reinforced Concrete Structures

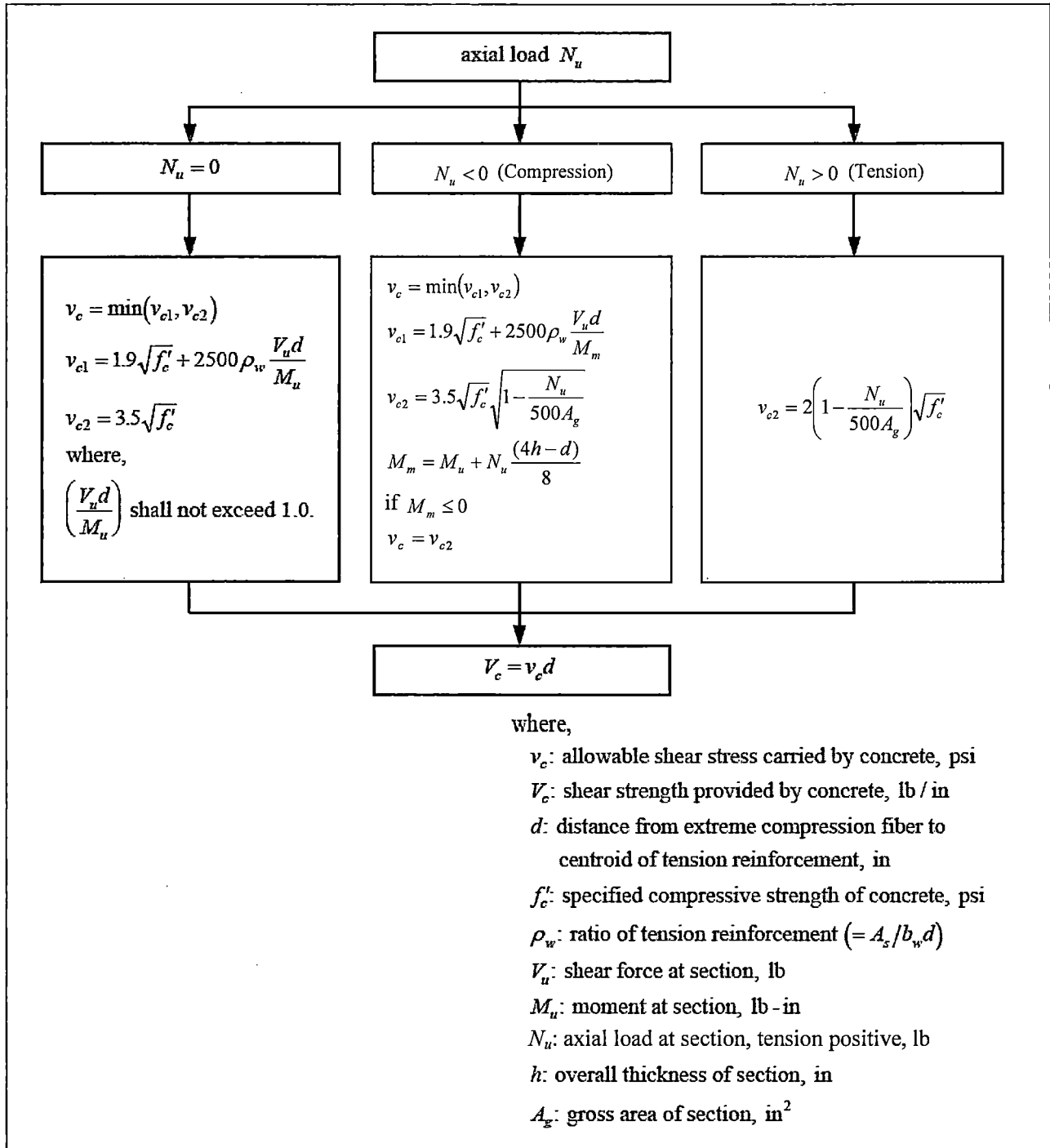


Figure 6.4.1-2 Calculation of Shear Strength Provided by Concrete

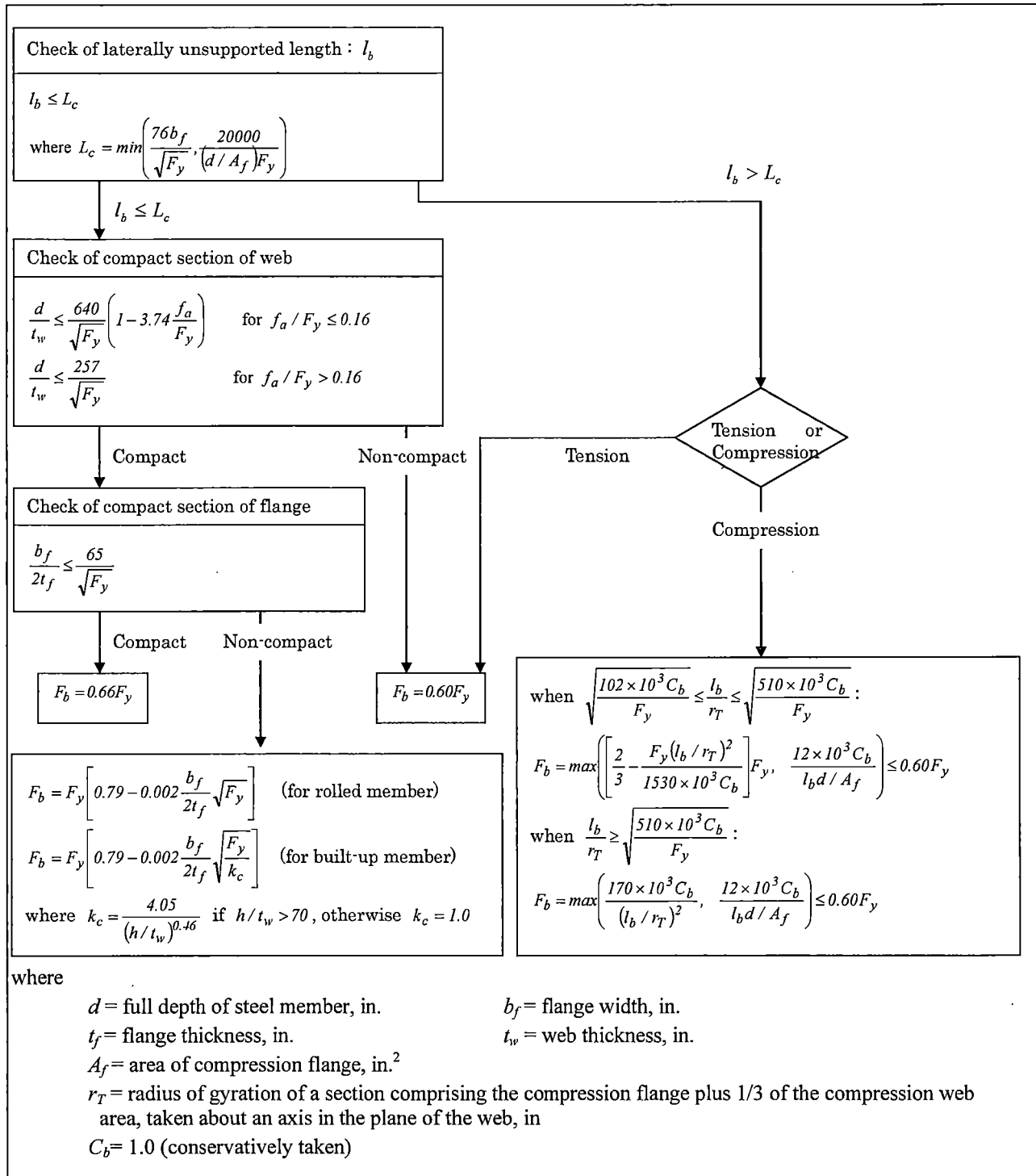


Figure 6.4.2-1 Allowable Stress of W-shaped Members (Strong Axis Bending)

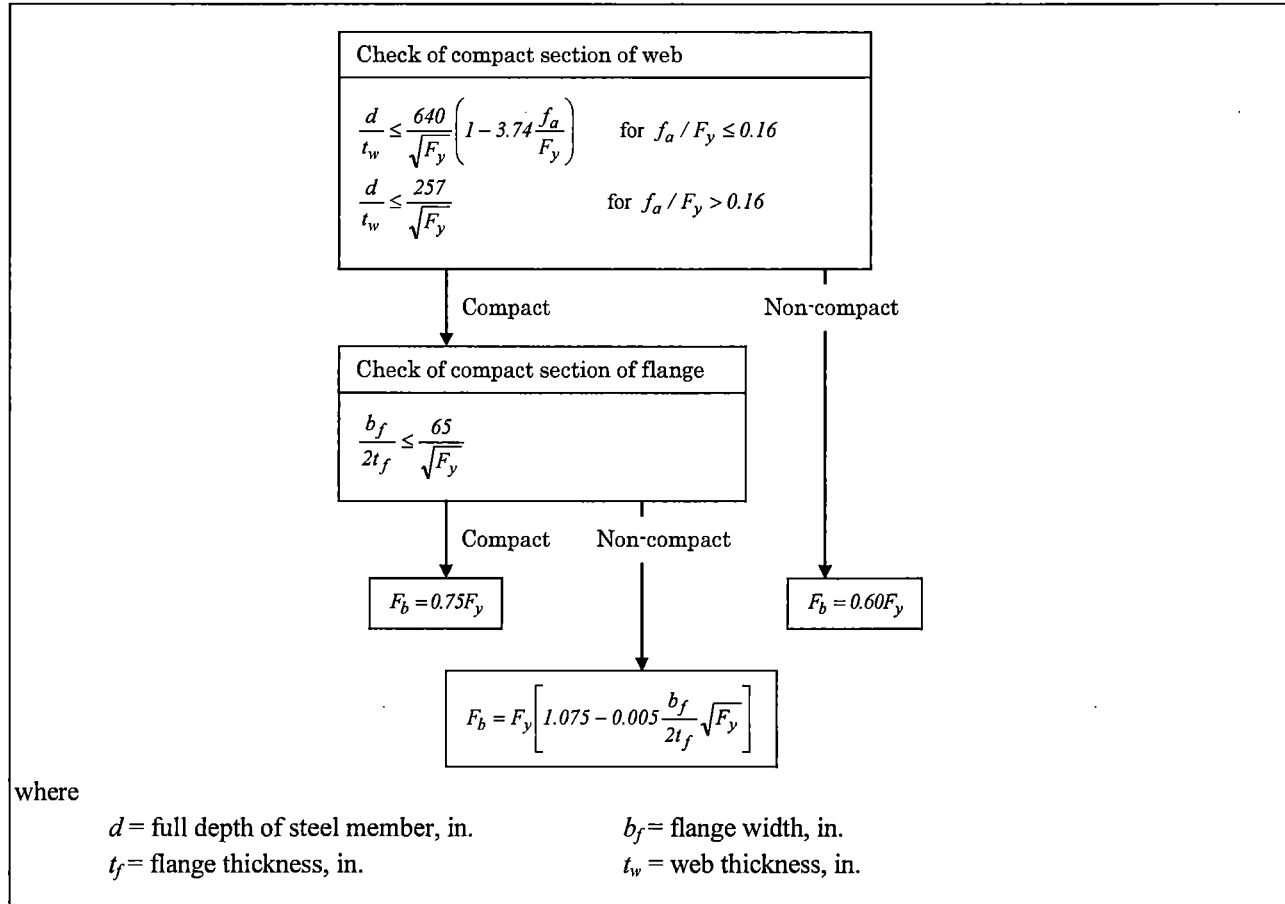


Figure 6.4.2-2 Allowable Stress of W-shaped Members (Weak Axis Bending)

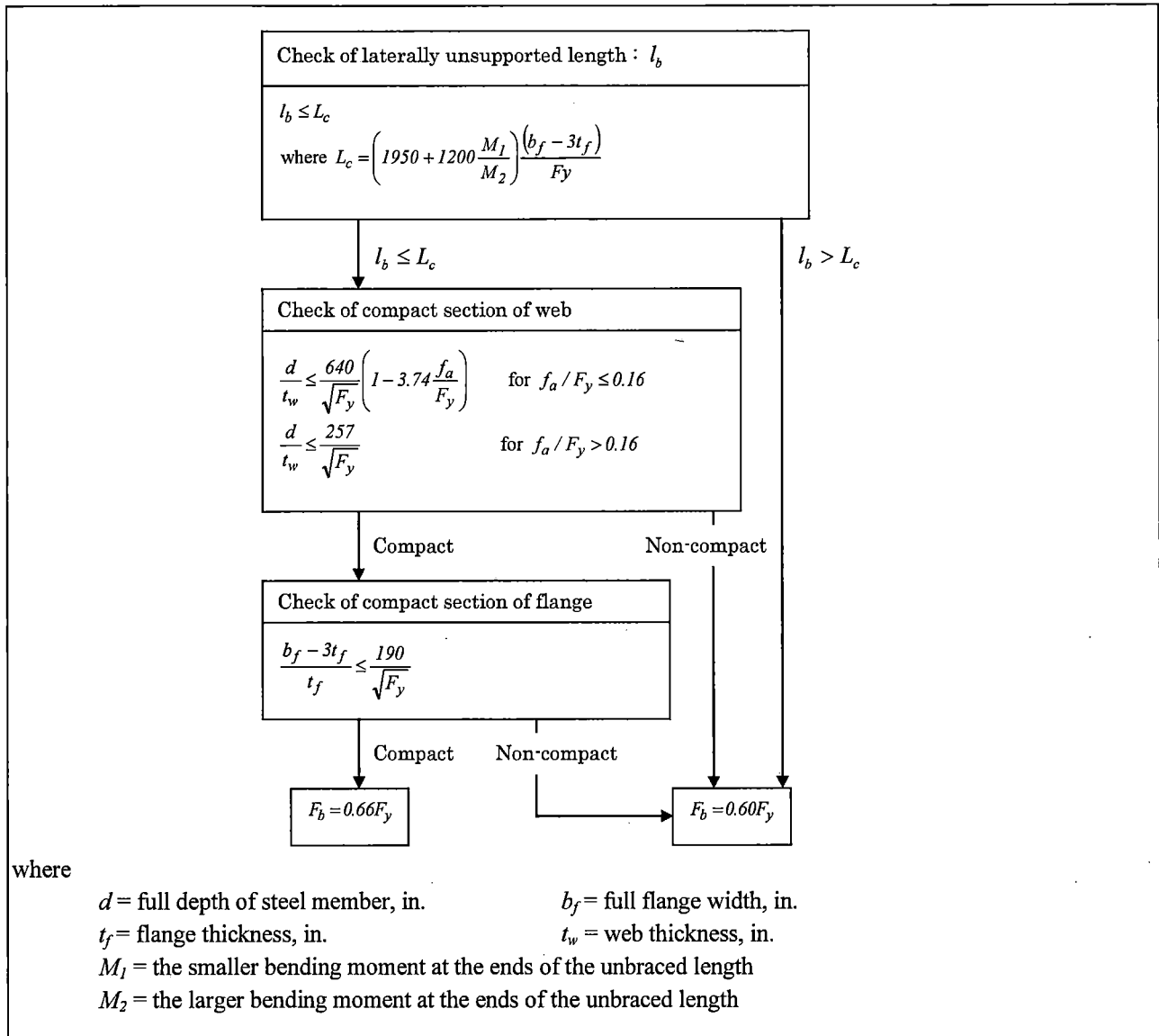
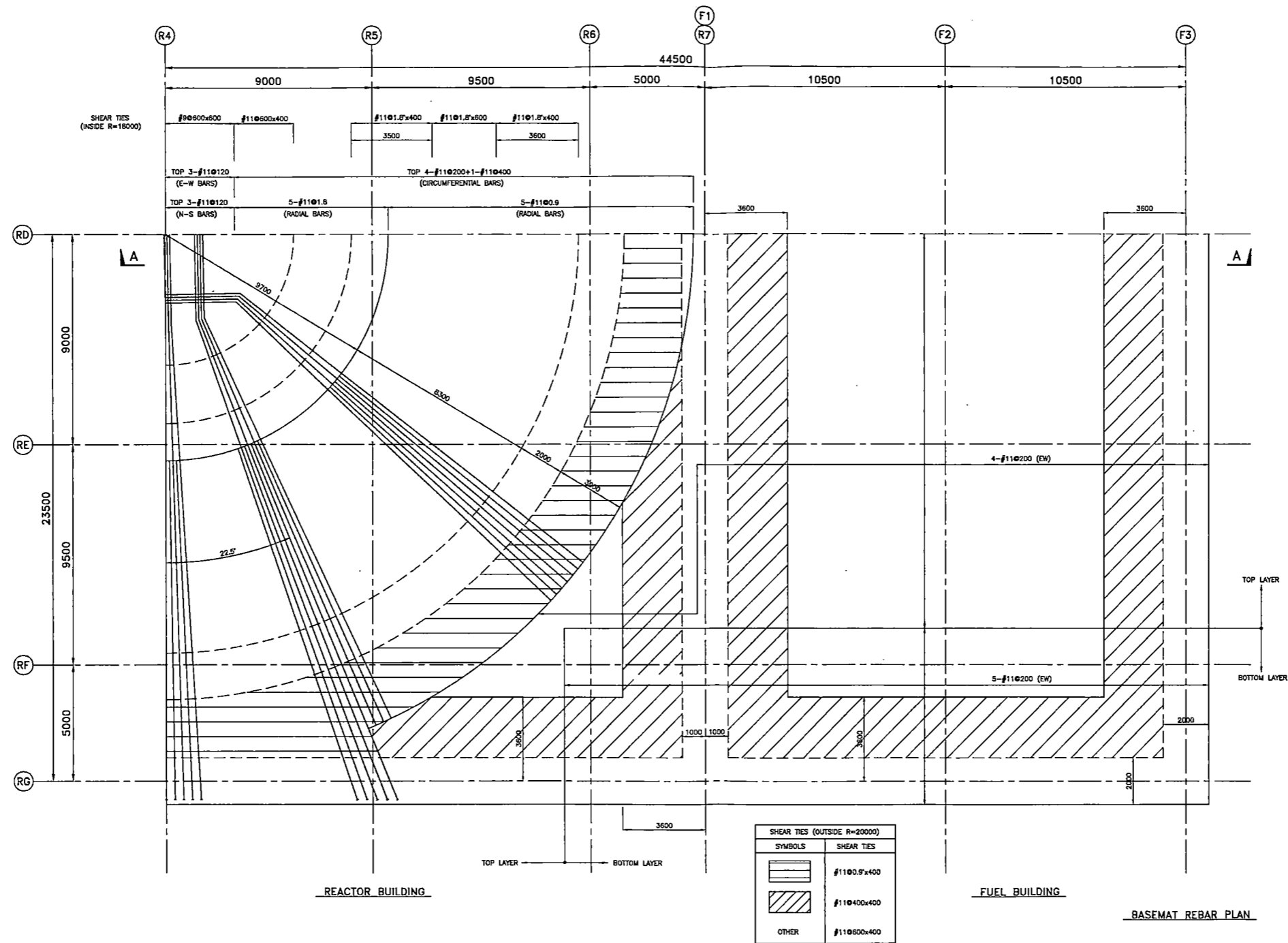


Figure 6.4.2-3 Allowable Bending Stress of Box Members



Note: Spacing of shear tie is described @(NS-dir.) x (EW-dir.) or @(Circumferential) x (Radial)

Figure 7.1-1 Reinforcing Steel of Foundation Mat: Plan

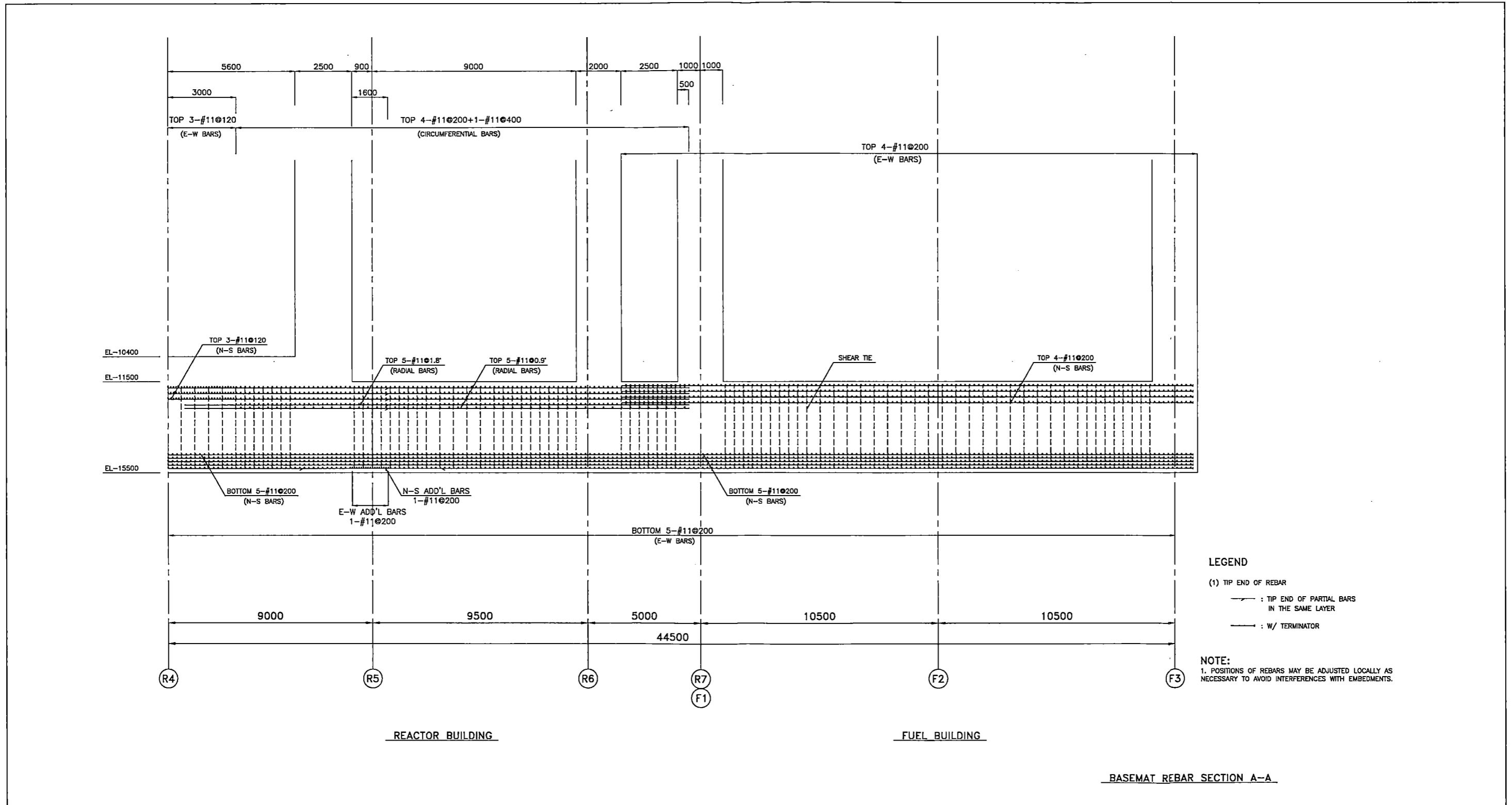
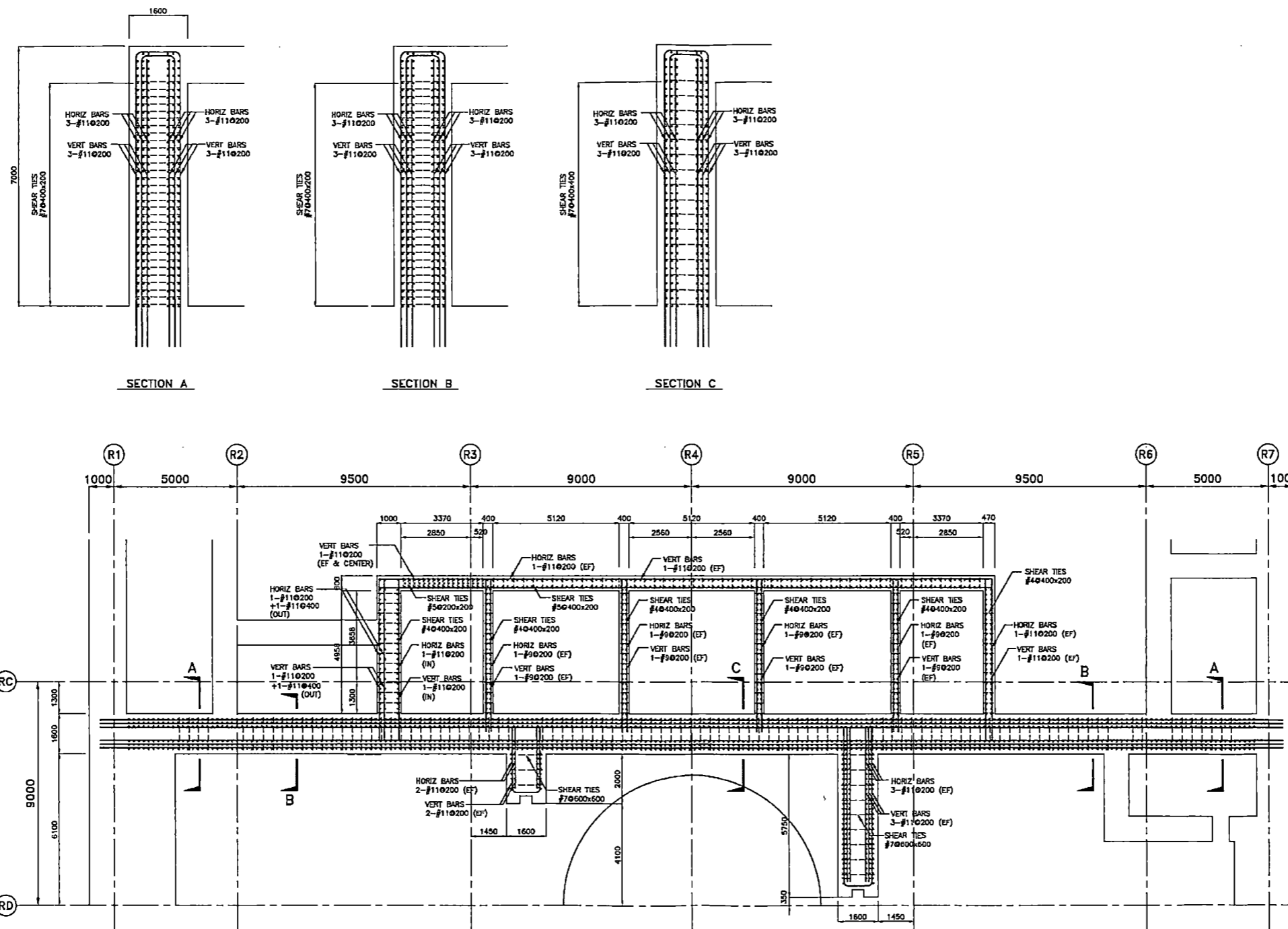


Figure 7.1-2 Reinforcing Steel of Foundation Mat: Section A-A



IC/PCCS POOL GIRDER AND WALLS

NOTE:
 1. POSITIONS OF REBARS MAY BE ADJUSTED LOCALLY AS NECESSARY TO AVOID INTERFERENCES WITH EMBEDMENTS.

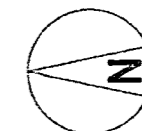


Figure 7.1-3 Reinforcing Steel of IC/PCCS Pool Girder



Figure 7.1-4 List of RB Wall and Slab Reinforcement

{{{Contains Security-Related Information – Withheld Under 10 CFR 2.390.}}}



HITACHI

WG3-U71-ERD-S-0004

SH NO. 492

REV. 0

of 538

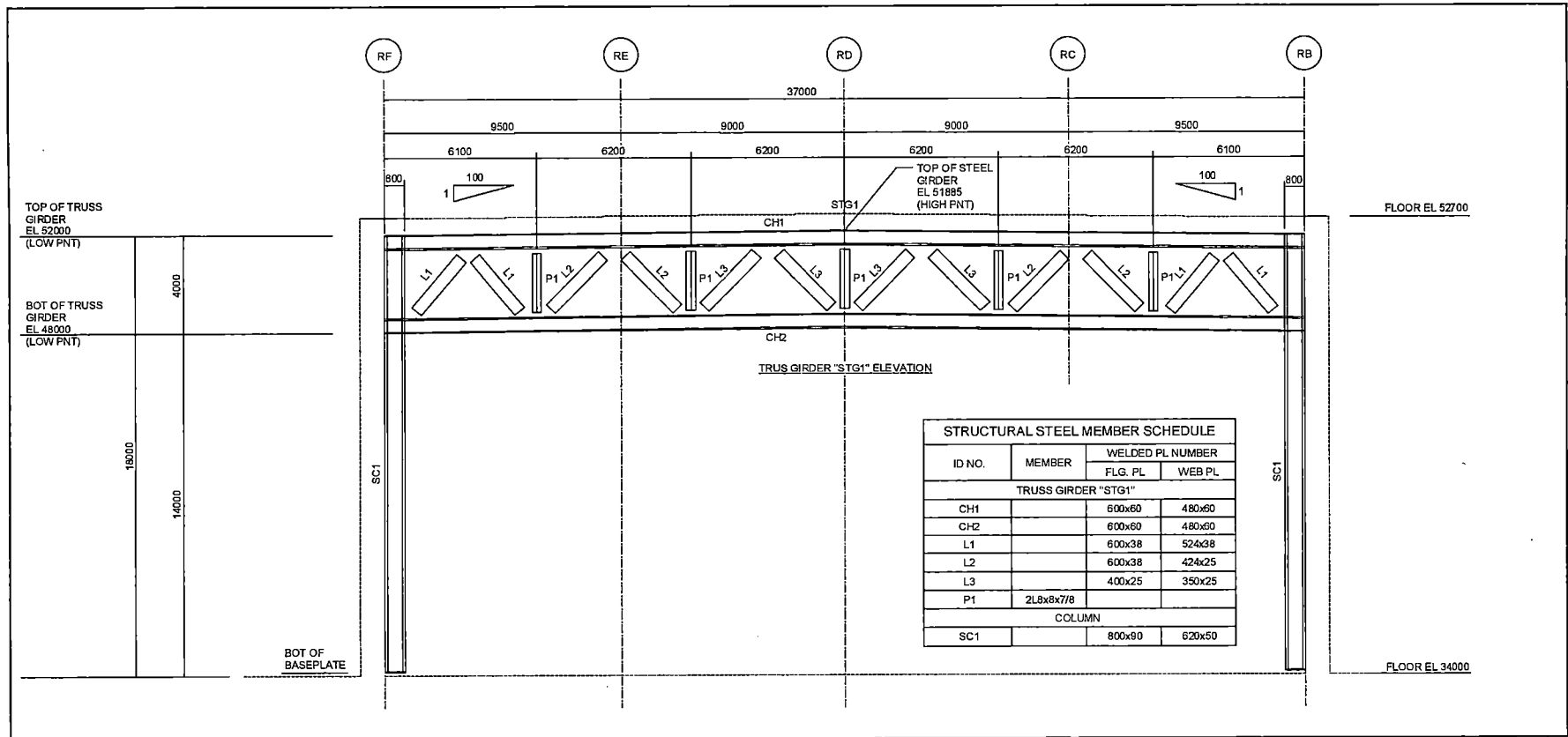


Figure 7.1-5 RB Roof Truss Structural Steel Member

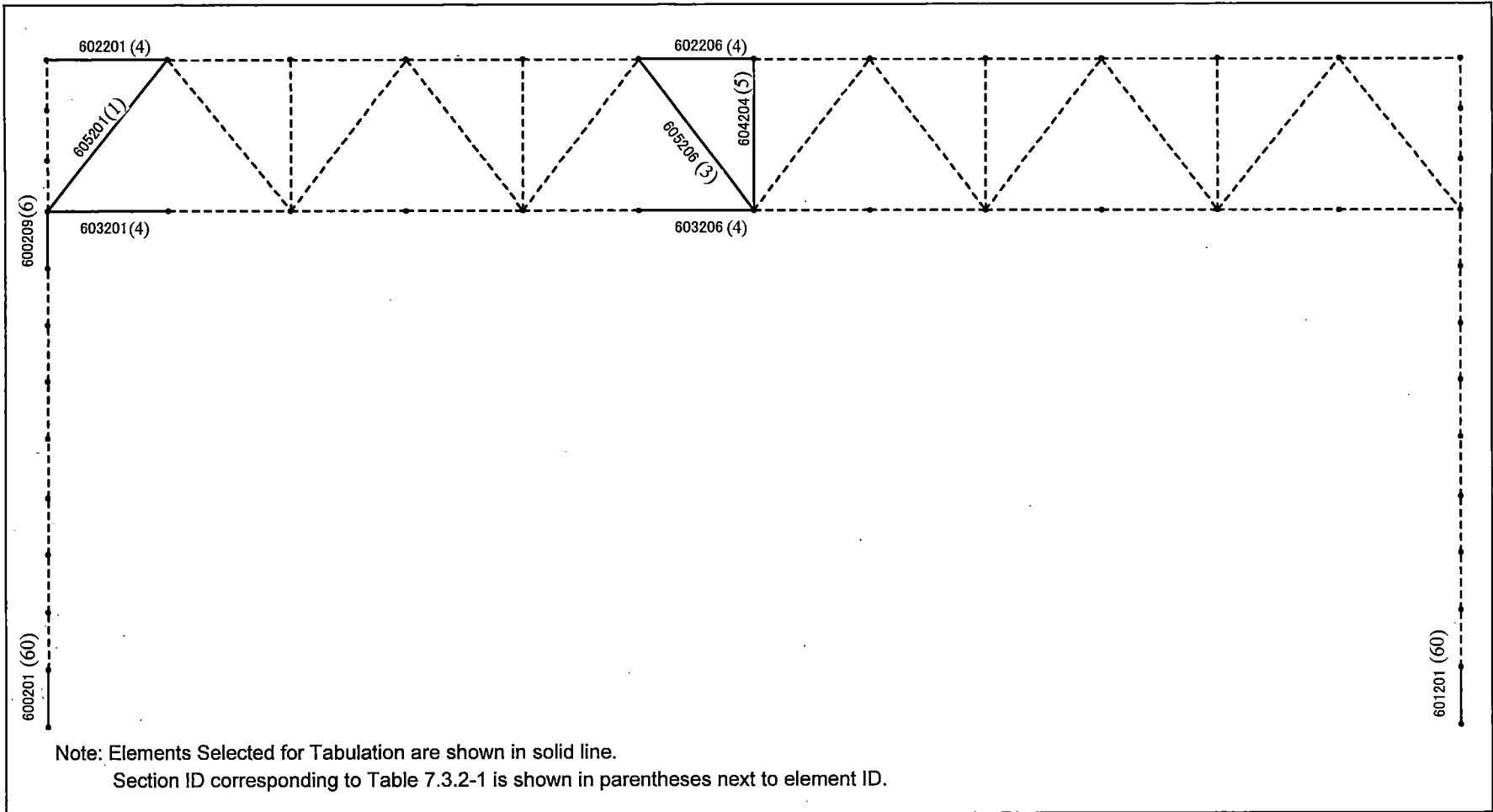


Figure 7.3.2-1 Elements Selected for Tabulation - RB Roof Truss and Supporting Column on R4 Column Line



HITACHI

WG3-U71-ERD-S-0004 SH NO. 494

REV. 0

of 538

APPENDIX A
COMPARISON WITH DCD DATA



List of Tables

Table A.1-1 Design Seismic Shear Loads for Horizontal.....496
Table A.1-2 Design Seismic Moment Loads for Horizontal501
Table A.1-3 Design Seismic Torsion Loads for Horizontal506
Table A.1-4 Vertical Acceleration.....510
Table A.1-5 Soil Pressure Due to an Earthquake514
Table A.1-6 Sloshing Loads for GDCS Pool.....515
Table A.1-7 Sloshing Loads for RPV Cavity / Dryer Separator / Fuel Buffer Pool.....516
Table A.1-8 Sloshing Loads for IC / PCCS Pool.....517
Table A.1-9 Sloshing Loads for Extension Pool A.....518
Table A.1-10 Sloshing Loads for Extension Pool B.....519
Table A.1-11 Sloshing Loads for Spent Fuel Pool520
Table A.2-1 Maximum Stress Ratios for Flexure and Membrane Forces: RB.....521
Table A.2-2 Maximum Stress Ratios for Membrane Compressive Forces: RB.....525
Table A.2-3 Calculation Results for Maximum Transverse Shear: RB.....529

List of Figures

None



HITACHI

**Table A.1-1 Design Seismic Shear Loads for Horizontal
(a) RB/FB**

Elev. (m)	Elem No.	Node No.	NS-direction			EW-direction		
			NA3 (MN)	DCD (MN)	Ratio (NA3/DCD)	NA3 (MN)	DCD (MN)	Ratio (NA3/DCD)
52.40*	1110	110	192.2	151.9	1.27	140.0	158.2	0.89
		109	192.2	151.9	1.27	140.0	158.2	0.89
34.00	1109	109	173.2	191.7	0.90	113.9	153.0	0.74
		108	173.2	191.7	0.90	113.9	153.0	0.74
27.00	1108	108	396.0	425.4	0.93	259.4	400.7	0.65
		107	396.0	425.4	0.93	259.4	400.7	0.65
22.50	1107	107	436.4	483.7	0.90	291.8	464.0	0.63
		106	436.4	483.7	0.90	291.8	464.0	0.63
17.50	1106	106	438.4	532.9	0.82	343.5	555.4	0.62
		105	438.4	532.9	0.82	343.5	555.4	0.62
13.57	1105	105	450.7	569.2	0.79	363.7	599.9	0.61
		104	450.7	569.2	0.79	363.7	599.9	0.61
9.06	1104	104	454.6	610.1	0.75	383.4	654.3	0.59
		103	454.6	610.1	0.75	383.4	654.3	0.59
4.65	1103	103	454.7	839.8	0.54	360.1	872.2	0.41
		102	454.7	839.8	0.54	360.1	872.2	0.41
-1.00	1102	102	240.0	871.4	0.28	226.6	938.5	0.24
		101	240.0	871.4	0.28	226.6	938.5	0.24
-6.40	1101	101	237.7	933.6	0.25	200.4	1029.7	0.19
-11.50		2	237.7	933.6	0.25	200.4	1029.7	0.19

*: The difference between the modeled elevation 52.4 m and the actual elevation 52.7 m at the RB roof is negligibly small.



HITACHI

WG3-U71-ERD-S-0004

SH NO. 497

REV. 0

of 538

Table A.1-1 Design Seismic Shear Loads for Horizontal (Continued)

(b) RCCV

Elev. (m)	Elem No.	Node No.	NS-direction			EW-direction		
			NA3 (MN)	DCD (MN)	Ratio (NA3/DCD)	NA3 (MN)	DCD (MN)	Ratio (NA3/DCD)
34	1209	209	130.9	137.0	0.96	133.2	183.2	0.73
		208	130.9	137.0	0.96	133.2	183.2	0.73
27	1208	208	141.1	164.9	0.86	151.9	248.5	0.61
		206	141.1	164.9	0.86	151.9	248.5	0.61
17.5	1206	206	184.1	230.2	0.80	158.4	290.2	0.55
		205	184.1	230.2	0.80	158.4	290.2	0.55
13.57	1205	205	207.9	263.4	0.79	173.4	326.2	0.53
		204	207.9	263.4	0.79	173.4	326.2	0.53
9.06	1204	204	225.4	304.2	0.74	201.2	365.8	0.55
		203	225.4	304.2	0.74	201.2	365.8	0.55
4.65	1203	203	109.2	225.8	0.48	125.7	289.4	0.43
		202	109.2	225.8	0.48	125.7	289.4	0.43
-1	1202	202	67.6	271.7	0.25	68.1	330.6	0.21
		201	67.6	271.7	0.25	68.1	330.6	0.21
-6.4	1201	201	70.7	261.5	0.27	55.1	303.5	0.18
-11.5		2	70.7	261.5	0.27	55.1	303.5	0.18



HITACHI

WG3-U71-ERD-S-0004

SH NO. 498

REV. 0

of 538

Table A.1-1 Design Seismic Shear Loads for Horizontal (Continued)

(c) RPV Pedestal and Vent Wall

Elev. (m)	Elem No.	Node No.	NS-direction			EW-direction		
			NA3 (MN)	DCD (MN)	Ratio (NA3/DCD)	NA3 (MN)	DCD (MN)	Ratio (NA3/DCD)
17.5	701	701	47.9	28.0	1.71	32.4	28.4	1.14
		702	47.9	28.0	1.71	32.4	28.4	1.14
14.5	702	702	47.1	29.5	1.60	32.4	30.5	1.06
		703	47.1	29.5	1.60	32.4	30.5	1.06
11.5	703	703	45.8	30.1	1.52	35.1	33.2	1.06
		704	45.8	30.1	1.52	35.1	33.2	1.06
8.5	704	704	44.7	30.4	1.47	36.5	35.3	1.03
		705	44.7	30.4	1.47	36.5	35.3	1.03
7.4625	705	705	39.1	31.0	1.26	29.4	29.4	1.00
		706	39.1	31.0	1.26	29.4	29.4	1.00
4.65	1303	303	20.5	32.8	0.63	16.9	44.8	0.38
		377	20.5	32.8	0.63	16.9	44.8	0.38
2.4165	1377	377	32.1	48.1	0.67	31.4	66.3	0.47
		302	32.1	48.1	0.67	31.4	66.3	0.47
-1	1302	302	22.1	65.6	0.34	15.7	81.4	0.19
		376	22.1	65.6	0.34	15.7	81.4	0.19
-2.75	1376	376	21.8	66.0	0.33	16.1	81.7	0.20
		301	21.8	66.0	0.33	16.1	81.7	0.20
-6.4	1301	301	29.8	104.4	0.29	22.4	121.2	0.18
-11.5		2	29.8	104.4	0.29	22.4	121.2	0.18



HITACHI

WG3-U71-ERD-S-0004

SH NO. 499

REV. 0

of 538

Table A.1-1 Design Seismic Shear Loads for Horizontal (Continued)

(d) RSW

Elev. (m)	Elem No.	Node No.	NS-direction			EW-direction		
			NA3 (MN)	DCD (MN)	Ratio (NA3/DCD)	NA3 (MN)	DCD (MN)	Ratio (NA3/DCD)
24.18	707	707	4.2	2.9	1.44	3.0	2.7	1.09
		708	4.2	2.9	1.44	3.0	2.7	1.09
20.2	708	708	20.8	14.6	1.43	11.1	11.7	0.95
		709	20.8	14.6	1.43	11.1	11.7	0.95
15.775	709	709	24.4	17.3	1.41	12.3	13.7	0.90
		710	24.4	17.3	1.41	12.3	13.7	0.90
11.35	710	710	27.1	19.9	1.36	13.5	15.9	0.85
		711	27.1	19.9	1.36	13.5	15.9	0.85
7.4625	711	711	26.6	41.1	0.65	22.2	35.6	0.62
		712	26.6	41.1	0.65	22.2	35.6	0.62
4.65	712	712	14.3	14.3	1.00	13.5	19.5	0.69
		713	14.3	14.3	1.00	13.5	19.5	0.69
2.4165	713	713	1.6	1.5	1.03	1.6	1.2	1.29
		714	1.6	1.5	1.03	1.6	1.2	1.29
1.96 -0.8	714	714	0.9	0.8	1.15	0.9	0.7	1.31
		715	0.9	0.8	1.15	0.9	0.7	1.31



HITACHI

WG3-U71-ERD-S-0004

SH NO. 500

REV. 0

of 538

Table A.1-1 Design Seismic Shear Loads for Horizontal (Continued)

(e) RPV

Elev. (m)	Elem No.	Node No.	NS-direction			EW-direction		
			NA3 (MN)	DCD (MN)	Ratio (NA3/DCD)	NA3 (MN)	DCD (MN)	Ratio (NA3/DCD)
3.215	844	845	18.6	7.2	2.59	7.9	7.0	1.13
2.365		846	18.6	7.2	2.59	7.9	7.0	1.13
8.453	871	815	29.8	18.6	1.60	18.8	17.9	1.05
7.4625		711	29.8	18.6	1.60	18.8	17.9	1.05



**Table A.1-2 Design Seismic Moment Loads for Horizontal
(a) RB/FB**

Elev. (m)	Elem No.	Node No.	NS-direction			EW-direction		
			NA3 (MN-m)	DCD (MN-m)	Ratio (NA3/DCD)	NA3 (MN-m)	DCD (MN-m)	Ratio (NA3/DCD)
52.4*	1110	110	2724	1642	1.66	2143	1808	1.19
			5838	4303	1.36	4488	4465	1.01
34	1109	109	8196	5585	1.47	5821	5497	1.06
			8719	6477	1.35	6389	6317	1.01
27	1108	108	9400	7685	1.22	7162	7106	1.01
			9599	8964	1.07	7958	8596	0.93
22.5	1107	107	11216	9905	1.13	8328	9193	0.91
			11424	11464	1.00	9227	11297	0.82
17.5	1106	106	12105	12386	0.98	9408	11935	0.79
			12349	13778	0.90	10195	13867	0.74
13.57	1105	105	12839	14298	0.90	10255	14377	0.71
			13651	16593	0.82	11216	16740	0.67
9.06	1104	104	13904	16966	0.82	11338	17191	0.66
			15231	19378	0.79	12506	19672	0.64
4.65	1103	103	9392	19064	0.49	6302	20192	0.31
			10952	23163	0.47	7759	24272	0.32
-1	1102	102	6545	23673	0.28	4819	24948	0.19
			7303	27655	0.26	5358	29263	0.18
-6.4	1101	101	4748	28126	0.17	3351	30038	0.11
			-11.5	2	5053	32235	0.16	3356

*: The difference between the modeled elevation 52.4 m and the actual elevation 52.7 m at the RB roof is negligibly small.



HITACHI

WG3-U71-ERD-S-0004

SH NO. 502

REV. 0

of 538

Table A.1-2 Design Seismic Moment Loads for Horizontal (Continued)

(b) RCCV

Elev. (m)	Elem No.	Node No.	NS-direction			EW-direction		
			NA3 (MN-m)	DCD (MN-m)	Ratio (NA3/DCD)	NA3 (MN-m)	DCD (MN-m)	Ratio (NA3/DCD)
34	1209	209	230	195	1.18	510	577	0.88
		208	1029	1057	0.97	1160	1496	0.78
27	1208	208	2162	1708	1.27	2303	2532	0.91
		206	2938	2959	0.99	3071	4368	0.70
17.5	1206	206	3259	3315	0.98	3667	4715	0.78
		205	3691	4147	0.89	3904	5761	0.68
13.57	1205	205	3817	4327	0.88	4203	5949	0.71
		204	4389	5404	0.81	4491	7264	0.62
9.06	1204	204	4481	5628	0.80	4853	7519	0.65
		203	5190	6785	0.76	5203	8909	0.58
4.65	1203	203	5523	6992	0.79	5470	9171	0.60
		202	5740	7958	0.72	5824	10581	0.55
-1	1202	202	6008	8076	0.74	6066	10738	0.56
		201	5924	9417	0.63	6035	12523	0.48
-6.4	1201	201	6053	9534	0.63	6141	12651	0.49
-11.5		2	5961	10836	0.55	6127	14200	0.43



HITACHI

WG3-U71-ERD-S-0004

SH NO. 503

REV. 0

of 538

Table A.1-2 Design Seismic Moment Loads for Horizontal (Continued)

(c) RPV Pedestal and Vent Wall

Elev. (m)	Elem No.	Node No.	NS-direction			EW-direction		
			NA3 (MN-m)	DCD (MN-m)	Ratio (NA3/DCD)	NA3 (MN-m)	DCD (MN-m)	Ratio (NA3/DCD)
17.5	701	701	107	78	1.37	62	85	0.73
		702	139	100	1.39	107	122	0.88
14.5	702	702	139	119	1.17	113	139	0.81
		703	279	184	1.52	204	217	0.94
11.5	703	703	280	185	1.51	207	225	0.92
		704	411	276	1.49	301	316	0.95
8.5	704	704	411	276	1.49	302	320	0.94
		705	458	307	1.49	338	352	0.96
7.4625	705	705	440	288	1.53	352	341	1.03
		706	513	356	1.44	427	407	1.05
4.65	1303	303	667	547	1.22	496	552	0.90
		377	651	567	1.15	502	594	0.85
2.4165	1377	377	793	694	1.14	614	730	0.84
		302	754	748	1.01	631	868	0.73
-1	1302	302	691	813	0.85	571	900	0.63
		376	658	903	0.73	555	1033	0.54
-2.75	1376	376	658	903	0.54	555	1033	0.39
		301	594	1091	0.54	524	1330	0.39
-6.4	1301	301	555	1131	0.34	518	1346	0.26
-11.5		2	553	1638	0.34	514	1963	0.26



HITACHI

WG3-U71-ERD-S-0004

SH NO. 504

REV. 0

of 538

Table A.1-2 Design Seismic Moment Loads for Horizontal (Continued)

(d) RSW

Elev. (m)	Elem No.	Node No.	NS-direction			EW-direction		
			NA3 (MN-m)	DCD (MN-m)	Ratio (NA3/DCD)	NA3 (MN-m)	DCD (MN-m)	Ratio (NA3/DCD)
24.18	707	707	2.5	2.1	1.19	2.2	1.7	1.29
		708	18.9	13.0	1.45	13.8	12.2	1.13
20.2	708	708	25.8	18.4	1.40	19.8	16.2	1.22
		709	113.5	79.0	1.44	59.3	64.3	0.92
15.775	709	709	116.7	81.9	1.42	61.3	66.8	0.92
		710	224.1	158.4	1.41	115.5	125.5	0.92
11.35	710	710	227.6	159.1	1.43	116.9	128.3	0.91
		711	331.9	236.2	1.41	169.3	187.6	0.90
7.4625	711	711	135.4	197.0	0.69	125.5	183.6	0.68
		712	169.6	292.4	0.58	151.7	251.3	0.60
4.65	712	712	156.8	117.5	1.33	142.3	118.8	1.20
		713	147.3	126.3	1.17	132.8	136.0	0.98
2.4165	713	713	4.0	3.3	1.21	4.0	3.2	1.25
		714	3.3	2.7	1.22	3.3	2.7	1.22
1.96 -0.8	714	714	3.0	2.5	1.20	3.0	2.4	1.25
		715	0.7	0.5	1.40	0.6	0.5	1.20



HITACHI

WG3-U71-ERD-S-0004

SH NO. 505

REV. 0

of 538

Table A.1-2 Design Seismic Moment Loads for Horizontal (Continued)

(e) RPV

Elev. (m)	Elem No.	Node No.	NS-direction			EW-direction		
			NA3 (MN-m)	DCD (MN-m)	Ratio (NA3/DCD)	NA3 (MN-m)	DCD (MN-m)	Ratio (NA3/DCD)
3.215	844	845	29.9	16.2	1.85	15.6	14.3	1.09
2.365		846	44.5	21.3	2.09	18.9	17.3	1.09
8.453	871	815	182.7	143.8	1.27	151.9	135.5	1.12
7.4625		711	176.6	141.3	1.25	147.4	132.9	1.11



**Table A.1-3 Design Seismic Torsion Loads for Horizontal
(a) RB/FB**

Elev. (m)	Elem No.	Node No.	Calculated Torsion			Accidental Torsion			Design Torsion		
			NA3 (MN-m)	DCD (MN-m)	Ratio (NA3/DCD)	NA3 (MN-m)	DCD (MN-m)	Ratio (NA3/DCD)	NA3 (MN-m)	DCD (MN-m)	Ratio (NA3/DCD)
52.4*	1110	110	1284	1379	0.93	471	388	1.22	1755	1766	0.99
			1284	1379	0.93	471	388	1.22	1755	1766	0.99
34	1109	109	1938	2405	0.81	424	470	0.90	2362	2874	0.82
			1938	2405	0.81	424	470	0.90	2362	2874	0.82
27	1108	108	2799	3329	0.84	1386	1489	0.93	4185	4822	0.87
			2799	3329	0.84	1386	1489	0.93	4185	4822	0.87
22.5	1107	107	4678	6093	0.77	1527	1693	0.90	6205	7786	0.80
			4678	6093	0.77	1527	1693	0.90	6205	7786	0.80
17.5	1106	106	4023	5068	0.79	1535	1944	0.79	5557	7012	0.79
			4023	5068	0.79	1535	1944	0.79	5557	7012	0.79
13.57	1105	105	4211	5245	0.80	1578	2100	0.75	5788	7344	0.79
			4211	5245	0.80	1578	2100	0.75	5788	7344	0.79
9.06	1104	104	4694	5985	0.78	1591	2290	0.69	6285	8275	0.76
			4694	5985	0.78	1591	2290	0.69	6285	8275	0.76
4.65	1103	103	5248	11425	0.46	1591	3053	0.52	6839	14478	0.47
			5248	11425	0.46	1591	3053	0.52	6839	14478	0.47
-1	1102	102	2718	11523	0.24	840	3285	0.26	3558	14808	0.24
			2718	11523	0.24	840	3285	0.26	3558	14808	0.24
-6.4	1101	101	2079	11690	0.18	832	3604	0.23	2910	15294	0.19
-11.5		2	2079	11690	0.18	832	3604	0.23	2910	15294	0.19

*: The difference between the modeled elevation 52.4 m and the actual elevation 52.7 m at the RB roof is negligibly small.



Table A.1-3 Design Seismic Torsion Loads for Horizontal (Continued)

(b) RCCV

Elev. (m)	Elem No.	Node No.	Calculated Torsion			Accidental Torsion			Design Torsion		
			NA3 (MN-m)	DCD (MN-m)	Ratio (NA3/DCD)	NA3 (MN-m)	DCD (MN-m)	Ratio (NA3/DCD)	NA3 (MN-m)	DCD (MN-m)	Ratio (NA3/DCD)
34	1209	209	29	36	0.81	266	366	0.73	296	402	0.73
		208	29	36	0.81	266	366	0.73	296	402	0.73
27	1208	208	1489	1814	0.82	304	497	0.61	1793	2311	0.78
		206	1489	1814	0.82	304	497	0.61	1793	2311	0.78
17.5	1206	206	1591	1982	0.80	368	580	0.63	1960	2562	0.76
		205	1591	1982	0.80	368	580	0.63	1960	2562	0.76
13.57	1205	205	1762	2186	0.81	416	652	0.64	2178	2838	0.77
		204	1762	2186	0.81	416	652	0.64	2178	2838	0.77
9.06	1204	204	2062	2616	0.79	451	732	0.62	2513	3348	0.75
		203	2062	2616	0.79	451	732	0.62	2513	3348	0.75
4.65	1203	203	1439	2870	0.50	251	579	0.43	1691	3449	0.49
		202	1439	2870	0.50	251	579	0.43	1691	3449	0.49
-1	1202	202	690	2926	0.24	136	661	0.21	826	3587	0.23
		201	690	2926	0.24	136	661	0.21	826	3587	0.23
-6.4	1201	201	349	1962	0.18	141	607	0.23	490	2569	0.19
-11.5		2	349	1962	0.18	141	607	0.23	490	2569	0.19



HITACHI

WG3-U71-ERD-S-0004

SH NO. 508

REV. 0

of 538

Table A.1-3 Design Seismic Torsion Loads for Horizontal (Continued)

(c) RPV Pedestal and Vent Wall

Elev. (m)	Elem No.	Node No.	Calculated Torsion			Accidental Torsion			Design Torsion		
			NA3 (MN-m)	DCD (MN-m)	Ratio (NA3/DCD)	NA3 (MN-m)	DCD (MN-m)	Ratio (NA3/DCD)	NA3 (MN-m)	DCD (MN-m)	Ratio (NA3/DCD)
17.5	701	701	107	73	1.47	40	12	3.38	147	85	1.74
		702	107	73	1.47	40	12	3.38	147	85	1.74
14.5	702	702	108	75	1.44	39	13	3.09	148	88	1.68
		703	108	75	1.44	39	13	3.09	148	88	1.68
11.5	703	703	111	77	1.44	38	14	2.76	149	91	1.64
		704	111	77	1.44	38	14	2.76	149	91	1.64
8.5	704	704	112	78	1.44	37	15	2.53	149	93	1.61
		705	112	78	1.44	37	15	2.53	149	93	1.61
7.4625	705	705	92	59	1.56	33	13	2.53	125	72	1.74
		706	92	59	1.56	33	13	2.53	125	72	1.74
4.65	1303	303	71	142	0.50	16	36	0.46	87	177	0.49
		377	71	142	0.50	16	36	0.46	87	177	0.49
2.4165	1377	377	86	172	0.50	26	53	0.48	112	225	0.50
		302	86	172	0.50	26	53	0.48	112	225	0.50
-1	1302	302	34	146	0.23	18	65	0.27	52	211	0.25
		376	34	146	0.23	18	65	0.27	52	211	0.25
-2.75	1376	376	34	146	0.23	17	65	0.27	52	212	0.25
		301	34	146	0.23	17	65	0.27	52	212	0.25
-6.4	1301	301	21	118	0.18	24	97	0.25	45	215	0.21
-11.5		2	21	118	0.18	24	97	0.25	45	215	0.21



HITACHI

Table A.1-3 Design Seismic Torsion Loads for Horizontal (Continued)

(d) RSW

Elev. (m)	Elem No.	Node No.	Calculated Torsion			Accidental Torsion			Design Torsion		
			NA3 (MN-m)	DCD (MN-m)	Ratio (NA3/DCD)	NA3 (MN-m)	DCD (MN-m)	Ratio (NA3/DCD)	NA3 (MN-m)	DCD (MN-m)	Ratio (NA3/DCD)
24.18	707	707	0.5	0.4	1.25	2.0	1.4	1.38	2.5	1.8	1.40
		708	0.5	0.4	1.25	2.0	1.4	1.38	2.5	1.8	1.40
20.2	708	708	1.7	1.4	1.21	9.8	6.9	1.43	11.6	8.3	1.39
		709	1.7	1.4	1.21	9.8	6.9	1.43	11.6	8.3	1.39
15.775	709	709	2.4	1.9	1.26	11.5	8.2	1.41	13.9	10.1	1.38
		710	2.4	1.9	1.26	11.5	8.2	1.41	13.9	10.1	1.38
11.35	710	710	3.0	2.4	1.25	12.8	9.4	1.36	15.8	11.8	1.34
		711	3.0	2.4	1.25	12.8	9.4	1.36	15.8	11.8	1.34
7.4625	711	711	22.9	22.0	1.04	12.6	19.4	0.65	35.5	41.4	0.86
		712	22.9	22.0	1.04	12.6	19.4	0.65	35.5	41.4	0.86
4.65	712	712	15.2	30.3	0.50	6.7	9.2	0.73	21.9	39.5	0.56
		713	15.2	30.3	0.50	6.7	9.2	0.73	21.9	39.5	0.56
2.4165	713	713	0.2	0.2	1.00	0.7	0.7	1.03	0.9	0.9	0.98
		714	0.2	0.2	1.00	0.7	0.7	1.03	0.9	0.9	0.98
1.96 -0.8	714	714	0.1	0.1	1.00	0.4	0.4	1.05	0.5	0.5	1.09
		715	0.1	0.1	1.00	0.4	0.4	1.05	0.5	0.5	1.09

**Table A.1-4 Vertical Acceleration****(a) RB/FB**

Elev. (m)	Node No.	Stick Model	NA3 (g)	DCD (g)	Ratio (NA3/DCD)
52.4*	110	RBFB	1.56	1.25	1.25
34	109	RBFB	1.20	0.83	1.45
27	108	RBFB	1.02	0.73	1.40
22.5	107	RBFB	0.92	0.73	1.26
17.5	106	RBFB	0.80	0.73	1.10
13.57	105	RBFB	0.72	0.74	0.97
9.06	104	RBFB	0.62	0.73	0.85
4.65	103	RBFB	0.56	0.78	0.72
-1	102	RBFB	0.57	0.76	0.75
-6.4	101	RBFB	0.53	0.68	0.78
-11.5	2	RBFB	0.51	0.63	0.81
-15.5	1	RBFB	0.52	0.51	1.02

*: The difference between the modeled elevation 52.4 m and the actual elevation 52.7 m at the RB roof is negligibly small.

(b) RCCV

Elev. (m)	Node No.	Stick Model	NA3 (g)	DCD (g)	Ratio (NA3/DCD)
34	209	RCCV	1.20	0.90	1.33
27	208	RCCV	1.12	0.88	1.27
17.5	206	RCCV	0.91	0.73	1.25
13.57	205	RCCV	0.82	0.78	1.05
9.06	204	RCCV	0.72	0.65	1.11
4.65	203	RCCV	0.65	0.69	0.94
-1	202	RCCV	0.58	0.59	0.98
-6.4	201	RCCV	0.55	0.59	0.93

**Table A.1-4 Vertical Acceleration (Continued)****(c) RPV Pedestal and Vent Wall**

Elev. (m)	Node No.	Stick Model	NA3 (g)	DCD (g)	Ratio (NA3/DCD)
17.5	701	VW	0.82	1.10	0.75
14.5	702	VW	0.86	1.04	0.83
11.5	703	VW	0.81	0.92	0.88
8.5	704	VW	0.72	0.77	0.93
7.4625	705	VW	0.67	0.70	0.95
4.65	706, 303	Pedestal	0.69	0.67	1.02
-1	302	Pedestal	0.59	0.59	1.01
-6.4	301	Pedestal	0.56	0.50	1.11

(d) RSW

Elev. (m)	Node No.	Stick Model	NA3 (g)	DCD (g)	Ratio (NA3/DCD)
24.18	707	RSW	1.30	0.97	1.35
20.2	708	RSW	1.23	0.94	1.31
15.775	709	RSW	0.99	0.84	1.18
11.35	710	RSW	0.78	0.76	1.02
7.4625	711	RSW	0.68	0.70	0.96
4.65	712	RSW	0.69	0.67	1.02
2.4615	713	RSW	0.64	0.64	1.00
1.96	714	RSW	0.64	0.64	1.00
-0.8	715	RSW	0.64	0.65	0.99

**Table A.1-4 Vertical Acceleration (Continued)****(e) Slab Oscillator**

Elev. (m)	Node No.	Stick Model	NA3 (g)	DCD (g)	Ratio (NA3/DCD)
52.4*	9101	Oscillator	0.33	1.20	0.28
	9102	Oscillator	1.33	1.82	0.73
	9103	Oscillator	6.27	3.14	2.00
	9104	Oscillator	2.62	2.26	1.16
	9105	Oscillator	2.42	2.32	1.04
	9106	Oscillator	3.74	2.99	1.25
	9107	Oscillator	3.22	2.80	1.15
	9108	Oscillator	2.50	2.61	0.96
	9109	Oscillator	1.53	---	---
34.00	9091	Oscillator	1.61	1.29	1.25
	9092	Oscillator	1.61	1.06	1.52
	9093	Oscillator	1.12	---	---
27.00	9081	Oscillator	1.64	1.16	1.41
	9082	Oscillator	1.52	0.99	1.54
	9083	Oscillator	1.30	1.09	1.19
	9084	Oscillator	1.67	1.31	1.27
	9085	Oscillator	1.46	0.97	1.51
	9086	Oscillator	1.12	---	---
	9087	Oscillator	1.03	---	---
22.50	9071	Oscillator	1.15	1.60	0.72
	9072	Oscillator	1.79	1.31	1.37
	9073	Oscillator	4.47	2.03	2.20
	9074	Oscillator	1.67	1.31	1.27
	9075	Oscillator	1.51	1.16	1.30
	9076	Oscillator	1.65	---	---
17.50	9061	Oscillator	3.65	1.79	2.04
	9062	Oscillator	2.62	1.49	1.76
	9063	Oscillator	1.17	0.82	1.43
	9064	Oscillator	2.56	1.84	1.39
	9065	Oscillator	1.28	1.42	0.90
	99064	Oscillator	0.99	1.07	0.93
	9066	Oscillator	1.09	---	---
	9067	Oscillator	0.91	---	---

*: The difference between the modeled elevation 52.4 m and the actual elevation 52.7 m at the RB roof is negligibly small.



Table A.1-4 Vertical Acceleration (Continued)

(e) Slab Oscillator

Elev. (m)	Node No.	Stick Model	NA3 (g)	DCD (g)	Ratio (NA3/DCD)
13.57	9051	Oscillator	1.11	0.81	1.37
	9052	Oscillator	1.25	1.46	0.86
	9053	Oscillator	0.99	---	---
	9054	Oscillator	0.83	---	---
9.06	9041	Oscillator	1.02	0.88	1.16
	9042	Oscillator	1.26	1.42	0.89
	9043	Oscillator	0.93	---	---
	9044	Oscillator	0.80	---	---
4.65	9031	Oscillator	1.62	1.17	1.38
	9032	Oscillator	0.89	0.97	0.92
	9033	Oscillator	1.12	1.02	1.10
	9034	Oscillator	1.81	1.51	1.20
	9035	Oscillator	1.09	1.38	0.79
	9036	Oscillator	0.94	---	---
	9037	Oscillator	0.82	---	---
-1.00	9021	Oscillator	0.97	1.12	0.87
	9022	Oscillator	2.07	1.45	1.43
	9023	Oscillator	0.98	1.01	0.97
	9024	Oscillator	1.12	0.89	1.26
	9025	Oscillator	1.21	1.34	0.90
	9026	Oscillator	1.63	1.57	1.04
	9027	Oscillator	0.93	0.88	1.06
	9028	Oscillator	0.96	---	---
	9029	Oscillator	1.30	---	---
	9030	Oscillator	0.87	---	---
-6.40	9011	Oscillator	0.84	0.92	0.91
	9012	Oscillator	1.17	0.92	1.27
	9013	Oscillator	1.52	1.35	1.13
	9014	Oscillator	1.19	---	---
	9015	Oscillator	1.03	---	---



Table A.1-5 Soil Pressure Due to an Earthquake

Elevation (m)	R1 and F3 Wall			RA and RG Wall			Note
	NA3 (MPa)	DCD (MPa)	Ratio (NA3/DCD)	NA3 (MPa)	DCD (MPa)	Ratio (NA3/DCD)	
4.65							Grade
-1	0.56	0.30	1.87	0.45	0.33	1.36	
-6.4	0.28	0.29	0.97	0.29	0.29	1.00	
-11.5	0.24	0.25	0.96	0.22	0.23	0.96	
-15.5	0.94	0.29	3.24	0.76	0.26	2.92	



Table A.1-6 Sloshing Loads for GDCS Pool

(a) Longitudinal Direction Motion

Depth d/H	Wall			Distance x/(L/2)	Floor		
	Pressure				Pressure		
	NA3 (kN/m ²)	DCD (kN/m ²)	Ratio (NA3/DCD)		NA3 (kN/m ²)	DCD (kN/m ²)	Ratio (NA3/DCD)
0.0	9.7	9.7	1.00	0.0	0.0	0.0	---
0.2	21.0	21.0	1.00	0.2	6.1	6.1	1.00
0.4	35.8	35.8	1.00	0.4	13.1	13.1	1.00
0.6	46.6	46.6	1.00	0.6	22.2	22.2	1.00
0.8	53.1	53.1	1.00	0.8	35.1	35.1	1.00
1.0	55.3	55.3	1.00	1.0	55.3	55.3	1.00

(b) Transversal Direction Motion

Depth d/H	Wall			Distance x/(L/2)	Floor		
	Pressure				Pressure		
	NA3 (kN/m ²)	DCD (kN/m ²)	Ratio (NA3/DCD)		NA3 (kN/m ²)	DCD (kN/m ²)	Ratio (NA3/DCD)
0.0	9.8	9.8	1.00	0.0	0.0	0.0	---
0.2	15.6	15.6	1.00	0.2	4.3	4.3	1.00
0.4	23.8	23.8	1.00	0.4	8.8	8.8	1.00
0.6	26.1	26.1	1.00	0.6	13.7	13.7	1.00
0.8	26.1	26.1	1.00	0.8	19.4	19.4	1.00
1.0	26.1	26.1	1.00	1.0	26.1	26.1	1.00

(c) Vertical Motion

Depth d/H	Wall			Floor		
	Pressure			NA3 (kN/m ²)	DCD (kN/m ²)	Ratio (NA3/DCD)
	NA3 (kN/m ²)	DCD (kN/m ²)	Ratio (NA3/DCD)			
0.0	0.0	0.0	---	68.0 for all floor area	53.4 for all floor area	1.27
0.2	13.6	10.7	1.27			
0.4	27.2	21.3	1.27			
0.6	40.8	32.0	1.27			
0.8	54.4	42.7	1.27			
1.0	68.0	53.4	1.27			



Table A.1-7 Sloshing Loads for RPV Cavity / Dryer Separator / Fuel Buffer Pool

(a) NS / EW Motion

Depth d/H	Wall			Distance x/(L/2)	Floor		
	Pressure				NA3 (kN/m ²)	DCD (kN/m ²)	Ratio (NA3/DCD)
	NA3 (kN/m ²)	DCD (kN/m ²)	Ratio (NA3/DCD)				
0.0	15.2	15.2	1.00	0.0	0.0	---	
0.2	23.1	23.1	1.00	0.2	8.0	8.0	1.00
0.4	37.0	37.0	1.00	0.4	16.7	16.7	1.00
0.6	47.8	47.8	1.00	0.6	27.0	27.0	1.00
0.8	54.5	54.5	1.00	0.8	39.9	39.9	1.00
1.0	56.7	56.7	1.00	1.0	56.7	56.7	1.00

(b) Vertical Motion

Depth d/H	Wall			Floor		
	NA3 (kN/m ²)	DCD (kN/m ²)	Ratio (NA3/DCD)	NA3 (kN/m ²)	DCD (kN/m ²)	Ratio (NA3/DCD)
0.0	0.0	0.0	---	76.2 for all floor area	58.5 for all floor area	1.30
0.2	15.2	11.7	1.30			
0.4	30.5	23.4	1.30			
0.6	45.7	35.1	1.30			
0.8	61.0	46.8	1.30			
1.0	76.2	58.5	1.30			



Table A.1-8 Sloshing Loads for IC / PCCS Pool

(a) NS / EW Motion

Depth d/H	Wall			Distance x/(L/2)	Floor		
	Pressure				Pressure		
	NA3 (kN/m ²)	DCD (kN/m ²)	Ratio (NA3/DCD)		NA3 (kN/m ²)	DCD (kN/m ²)	Ratio (NA3/DCD)
0.0	9.1	9.1	1.00	0.0	0.0	0.0	---
0.2	13.6	13.6	1.00	0.2	4.6	4.6	1.00
0.4	21.7	21.7	1.00	0.4	9.5	9.5	1.00
0.6	26.7	26.7	1.00	0.6	14.8	14.8	1.00
0.8	28.2	28.2	1.00	0.8	21.0	21.0	1.00
1.0	28.2	28.2	1.00	1.0	28.2	28.2	1.00

(b) Vertical Motion

Depth d/H	Wall			Floor		
	NA3 (kN/m ²)	DCD (kN/m ²)	Ratio (NA3/DCD)	NA3 (kN/m ²)	DCD (kN/m ²)	Ratio (NA3/DCD)
0.0	0.0	0.0	---	54.6 for all floor area	41.9 for all floor area	1.30
0.2	10.9	8.4	1.30			
0.4	21.8	16.8	1.30			
0.6	32.8	25.1	1.30			
0.8	43.7	33.5	1.30			
1.0	54.6	41.9	1.30			



Table A.1-9 Sloshing Loads for Extension Pool A

(a) NS Motion

Depth d/H	Wall			Distance x/(L/2)	Floor		
	Pressure				NA3 (kN/m ²)	DCD (kN/m ²)	Ratio (NA3/DCD)
	NA3 (kN/m ²)	DCD (kN/m ²)	Ratio (NA3/DCD)				
0.0	4.8	4.8	1.00	0.0	0.0	0.0	---
0.2	16.5	16.5	1.00	0.2	1.3	1.3	1.00
0.4	28.6	28.6	1.00	0.4	2.7	2.7	1.00
0.6	37.3	37.3	1.00	0.6	4.7	4.7	1.00
0.8	42.5	42.5	1.00	0.8	12.3	12.3	1.00
1.0	44.3	44.3	1.00	1.0	44.3	44.3	1.00

(b) EW Motion

Depth d/H	Wall			Distance x/(L/2)	Floor		
	Pressure				NA3 (kN/m ²)	DCD (kN/m ²)	Ratio (NA3/DCD)
	NA3 (kN/m ²)	DCD (kN/m ²)	Ratio (NA3/DCD)				
0.0	7.8	7.8	1.00	0.0	0.0	0.0	---
0.2	12.9	12.9	1.00	0.2	3.9	3.9	1.00
0.4	20.3	20.3	1.00	0.4	8.1	8.1	1.00
0.6	23.8	23.8	1.00	0.6	12.6	12.6	1.00
0.8	24.0	24.0	1.00	0.8	17.8	17.8	1.00
1.0	24.0	24.0	1.00	1.0	24.0	24.0	1.00

(c) Vertical Motion

Depth d/H	Wall			Floor		
	Pressure			NA3 (kN/m ²)	DCD (kN/m ²)	Ratio (NA3/DCD)
	NA3 (kN/m ²)	DCD (kN/m ²)	Ratio (NA3/DCD)			
0.0	0.0	0.0	---	54.6 for all floor area	41.9 for all floor area	1.30
0.2	10.9	8.4	1.30			
0.4	21.8	16.8	1.30			
0.6	32.8	25.1	1.30			
0.8	43.7	33.5	1.30			
1.0	54.6	41.9	1.30			



Table A.1-10 Sloshing Loads for Extension Pool B

(a) NS Motion

Depth d/H	Wall			Distance x/(L/2)	Floor		
	Pressure				Pressure		
	NA3 (kN/m ²)	DCD (kN/m ²)	Ratio (NA3/DCD)		NA3 (kN/m ²)	DCD (kN/m ²)	Ratio (NA3/DCD)
0.0	7.8	7.8	1.00	0.0	0.0	---	
0.2	12.5	12.5	1.00	0.2	3.5	3.5	1.00
0.4	19.2	19.2	1.00	0.4	7.2	7.2	1.00
0.6	21.5	21.5	1.00	0.6	11.3	11.3	1.00
0.8	21.5	21.5	1.00	0.8	16.0	16.0	1.00
1.0	21.5	21.5	1.00	1.0	21.5	21.5	1.00

(b) EW Motion

Depth d/H	Wall			Distance x/(L/2)	Floor		
	Pressure				Pressure		
	NA3 (kN/m ²)	DCD (kN/m ²)	Ratio (NA3/DCD)		NA3 (kN/m ²)	DCD (kN/m ²)	Ratio (NA3/DCD)
0.0	13.7	13.7	1.00	0.0	0.0	---	
0.2	18.2	18.2	1.00	0.2	5.5	5.5	1.00
0.4	27.8	27.8	1.00	0.4	11.7	11.7	1.00
0.6	35.5	35.5	1.00	0.6	19.1	19.1	1.00
0.8	40.3	40.3	1.00	0.8	28.7	28.7	1.00
1.0	41.9	41.9	1.00	1.0	41.9	41.9	1.00

(c) Vertical Motion

Depth d/H	Wall			Floor		
	Pressure			NA3 (kN/m ²)	DCD (kN/m ²)	Ratio (NA3/DCD)
	NA3 (kN/m ²)	DCD (kN/m ²)	Ratio (NA3/DCD)			
0.0	0.0	0.0	---	54.6 for all floor area	41.9 for all floor area	1.30
0.2	10.9	8.4	1.30			
0.4	21.8	16.8	1.30			
0.6	32.8	25.1	1.30			
0.8	43.7	33.5	1.30			
1.0	54.6	41.9	1.30			



Table A.1-11 Sloshing Loads for Spent Fuel Pool

(a) NS Motion

Depth d/H	Wall			Distance x/(L/2)	Floor		
	Pressure				NA3 (kN/m ²)	DCD (kN/m ²)	Ratio (NA3/DCD)
	NA3 (kN/m ²)	DCD (kN/m ²)	Ratio (NA3/DCD)				
0.0	12.3	12.3	1.00	0.0	0.0	---	
0.2	23.6	22.6	1.04	0.2	7.4	7.1	1.04
0.4	37.8	36.1	1.05	0.4	15.2	14.5	1.05
0.6	44.6	42.6	1.05	0.6	23.7	22.7	1.05
0.8	45.2	43.2	1.05	0.8	33.6	32.1	1.05
1.0	45.2	43.2	1.05	1.0	45.2	43.2	1.05

(b) EW Motion

Depth d/H	Wall			Distance x/(L/2)	Floor		
	Pressure				NA3 (kN/m ²)	DCD (kN/m ²)	Ratio (NA3/DCD)
	NA3 (kN/m ²)	DCD (kN/m ²)	Ratio (NA3/DCD)				
0.0	11.8	11.8	1.00	0.0	0.0	---	
0.2	24.2	23.2	1.04	0.2	8.5	8.2	1.04
0.4	40.0	38.2	1.05	0.4	17.5	16.7	1.05
0.6	49.4	47.2	1.05	0.6	27.4	26.2	1.05
0.8	52.2	49.8	1.05	0.8	38.7	37.0	1.05
1.0	52.2	49.8	1.05	1.0	52.2	49.8	1.05

(c) Vertical Motion

Depth d/H	Wall			NA3 (kN/m ²)	DCD (kN/m ²)	Ratio (NA3/DCD)
	NA3 (kN/m ²)	DCD (kN/m ²)	Ratio (NA3/DCD)			
0.0	0.0	0.0	---	98.5 for all floor area	98.5 for all floor area	1.00
0.2	19.7	19.7	1.00			
0.4	39.4	39.4	1.00			
0.6	59.1	59.1	1.00			
0.8	78.8	78.8	1.00			
1.0	98.5	98.5	1.00			



HITACHI

WG3-U71-ERD-S-0004

SH NO. 521

REV. 0

of 538

Table A.2-1 Maximum Stress Ratios for Flexure and Membrane Forces: RB

Location	Element ID	Concrete				Ratio (NA3/DCD)
		NA3		DCD		
		σ/σ_s	Load ID	σ/σ_s	Load ID	
18 Wall Below RCCV Bottom	6	0.433	7501	0.767	7501	0.57
	13	0.518	7501	0.692	7501	0.75
	24	0.568	7501	0.696	7501	0.82
19 Wall Below RCCV Mid-Height	806	0.298	8514	0.373	7441	0.80
	813	0.339	8514	0.417	7441	0.81
	824	0.367	8514	0.463	7421	0.79
20 Wall Below RCCV Top	1606	0.542	6241	0.542	6241	1.00
	1613	0.625	6341	0.871	7471	0.72
	1624	0.639	8507	0.616	6471	1.04
21 Exterior Wall @ EL-11.50 ~10.50m	20011	0.338	7251	0.817	7301	0.41
	20023	0.467	7492	0.550	7492	0.85
	30010	0.302	7501	0.523	7501	0.58
	30020	0.192	7211	0.255	7571	0.75
	40001	0.284	7481	0.393	7431	0.72
	40011	0.338	7501	0.497	7501	0.68
22 Exterior Wall @ EL4.65 ~6.60m	22011	0.388	7561	0.489	7211	0.79
	22023	0.391	8511	0.384	7492	1.02
	32010	0.235	7131	0.278	7201	0.85
	32020	0.257	7371	0.262	7301	0.98
	42001	0.269	7201	0.283	7301	0.95
	42011	0.260	7501	0.333	7201	0.78
23 Exterior Wall @ EL22.50 ~24.60m	24211	0.336	7501	0.373	7201	0.90
	24224	0.436	7961	0.382	7581	1.14
	34210	0.231	5026	0.217	4022	1.07
	34220	0.195	7482	0.229	7441	0.85
	44201	0.230	8502	0.213	7561	1.08



HITACHI

WG3-U71-ERD-S-0004

SH NO. 522

REV. 0

of 538

Table A.2-1 Maximum Stress Ratios for Flexure and Membrane Forces: RB (Continued)

Location	Element ID	Concrete				Ratio (NA3/DCD)
		NA3		DCD		
		σ/σ_s	Load ID	σ/σ_s	Load ID	
24 Basemat @ Wall Below RCCV	90140	0.500	7571	0.570	7511	0.88
	90182	0.244	7491	0.257	7491	0.95
	90111	0.237	7571	0.233	7491	1.02
25 Slab EL4.65m @ RCCV	93140	0.478	8514	0.491	7482	0.97
	93182	0.741	8514	0.690	7441	1.07
	93111	0.689	8514	0.612	7441	1.13
26 Slab EL17.5m @ RCCV	96144	0.412	8511	0.409	7482	1.01
	96186	0.483	8513	0.397	7133	1.22
	96113	0.588	8513	0.524	7482	1.12
27 Slab EL27.0m @ RCCV	98472	0.890	8512	0.566	6001	1.57
	98514	0.668	8513	0.200	6001	3.34
	98424	0.844	8514	0.600	6001	1.41
28 Pool Girder @ Storage Pool	123054	0.669	8512	0.595	6001	1.13
	123154	0.455	8512	0.211	6001	2.16
29 Pool Girder @ Cavity	123062	0.464	6971	0.212	6001	2.19
	123162	0.365	7461	0.201	6001	1.82
30 Pool Girder @ Fuel Pool	123067	0.888	8513	0.514	6001	1.73
	123167	0.601	8505	0.494	6001	1.22
31 MS Tunnel Wall and Slab	150122	0.517	2021	0.516	2021	1.00
	96611	0.383	7521	0.361	7521	1.06
	98614	0.284	7371	0.269	7341	1.05
32 IC/PCCS Pool Wall in NS Dir.	125051	0.272	9005	0.097	6001	2.80
	125151	0.292	9012	0.212	6001	1.38
	125055	0.340	8512	0.187	6001	1.82
	125155	0.287	9003	0.173	6001	1.66



Table A.2-1 Maximum Stress Ratios for Flexure and Membrane Forces: RB (Continued)

Location	Element ID	Primary Reinforcement																			
		Direction 1									Direction 2										
		In/Top			Out/Bottom			Ratio			In/Top			Out/Bottom			Ratio				
		NA3		DCD		Ratio (NA3/DCD)	NA3		DCD		Ratio (NA3/DCD)	NA3		DCD		Ratio (NA3/DCD)	NA3		DCD		Ratio (NA3/DCD)
σ/σ_a	Load ID	σ/σ_a	Load ID		σ/σ_a	Load ID	σ/σ_a	Load ID		σ/σ_a	Load ID	σ/σ_a	Load ID		σ/σ_a	Load ID	σ/σ_a	Load ID			
18 Wall Below RCCV Bottom	6	0.433	7501	0.767	7501	0.57	0.249	7721	0.885	7992	0.28	0.182	7641	0.622	7641	0.29	0.250	7851	0.918	7801	0.27
	13	0.518	7501	0.692	7501	0.75	0.206	8081	0.607	7801	0.34	0.157	7721	0.433	7622	0.36	0.250	7851	0.674	7801	0.37
	24	0.568	7501	0.696	7501	0.82	0.202	7992	0.630	7601	0.32	0.172	7672	0.452	7621	0.38	0.252	7642	0.598	7641	0.42
19 Wall Below RCCV Mid-Height	806	0.298	8514	0.373	7441	0.80	0.284	8021	0.753	8081	0.38	0.189	7673	0.458	8021	0.41	0.209	7671	0.580	8001	0.36
	813	0.339	8514	0.417	7441	0.81	0.177	9011	0.578	7821	0.31	0.132	9011	0.363	7982	0.36	0.120	7651	0.540	7611	0.22
	824	0.367	8514	0.463	7421	0.79	0.223	7921	0.737	7621	0.30	0.140	7651	0.447	7621	0.31	0.200	7971	0.585	7801	0.34
20 Wall Below RCCV Top	1606	0.542	6241	0.542	6241	1.00	0.383	7701	0.701	7601	0.55	0.364	7471	0.521	7421	0.70	0.380	7701	0.738	7602	0.51
	1613	0.625	6341	0.871	7471	0.72	0.263	7651	0.533	7601	0.49	0.302	7471	0.393	7421	0.77	0.335	7701	0.673	7602	0.50
	1624	0.639	8507	0.616	6471	1.04	0.378	7751	0.693	7701	0.55	0.363	7471	0.510	7441	0.71	0.380	7602	0.698	7602	0.54
21 Exterior Wall @ EL-11.50 ~10.50m	20011	0.338	7251	0.817	7301	0.41	0.391	8514	0.906	7482	0.43	0.298	7821	0.832	7841	0.36	0.568	8514	0.912	7482	0.62
	20023	0.467	7492	0.550	7492	0.85	0.214	7492	0.264	7492	0.81	0.099	7491	0.169	8001	0.58	0.228	7992	0.334	7992	0.68
	30010	0.302	7501	0.523	7501	0.58	0.183	9014	0.570	7931	0.32	0.196	7961	0.582	7941	0.34	0.209	7961	0.813	7981	0.26
	30020	0.192	7211	0.255	7571	0.75	0.048	8061	0.087	7601	0.55	0.111	7281	0.168	7981	0.66	0.061	7601	0.300	7601	0.20
	40001	0.284	7481	0.393	7431	0.72	0.078	8001	0.174	7992	0.45	0.170	7461	0.276	7411	0.61	0.074	7481	0.371	7601	0.20
	40011	0.338	7501	0.497	7501	0.68	0.122	7971	0.667	7921	0.18	0.143	8011	0.735	7982	0.19	0.176	7961	0.816	7931	0.22
22 Exterior Wall @ EL4.65 ~6.60m	22011	0.388	7561	0.489	7211	0.79	0.728	8513	0.970	7482	0.75	0.591	8513	0.748	7482	0.79	0.723	7871	0.905	7821	0.80
	22023	0.391	8511	0.384	7492	1.02	0.367	8001	0.414	8001	0.89	0.345	7701	0.434	7701	0.79	0.487	7601	0.643	8001	0.76
	32010	0.235	7131	0.278	7201	0.85	0.552	7482	0.812	7441	0.68	0.635	8514	0.737	7482	0.86	0.525	7173	0.893	7321	0.59
	32020	0.257	7371	0.262	7301	0.98	0.429	7431	0.518	7411	0.83	0.375	9012	0.435	7982	0.86	0.719	7831	0.767	7811	0.94
	42001	0.269	7201	0.283	7301	0.95	0.385	7751	0.489	7411	0.79	0.253	7991	0.346	7801	0.73	0.698	9012	0.673	7631	1.04
	42011	0.260	7501	0.333	7201	0.78	0.504	8511	0.684	7801	0.74	0.518	8511	0.505	7421	1.02	0.571	9014	0.800	7831	0.71
23 Exterior Wall @ EL22.50 ~24.60m	24211	0.336	7501	0.373	7201	0.90	0.662	7461	0.901	7481	0.74	0.571	8511	0.554	7241	1.03	0.725	7461	0.853	7481	0.85
	24224	0.436	7961	0.382	7581	1.14	0.699	7481	0.702	7461	1.00	0.451	7601	0.493	7612	0.92	0.878	7632	0.843	7613	1.04
	34210	0.231	5026	0.217	4022	1.07	0.655	7482	0.815	7482	0.80	0.909	7482	0.907	7482	1.00	0.520	8514	0.534	7371	0.97
	34220	0.195	7482	0.229	7441	0.85	0.491	8511	0.433	7941	1.13	0.250	8512	0.317	8081	0.79	0.484	7261	0.466	7991	1.04
	44201	0.230	8502	0.213	7561	1.08	0.498	7441	0.562	7441	0.89	0.312	7581	0.369	7581	0.84	0.545	7461	0.566	7431	0.96

Note *: Wall Below RCCV Direction1 : Hoop, Direction2 : Vertical
 Exterior Wall Direction1 : Horizontal, Direction2 : Vertical
 Slab Direction1 : N-S, Direction2 : E-W
 Pool Girder Direction1 : Horizontal, Direction2 : Vertical
 MS Tunnel Wall Direction1 : Horizontal, Direction2 : Vertical
 MS Tunnel Slab Direction1 : N-S, Direction2 : E-W
 σ and σ_a are calculated and allowable stress.



HITACHI

WG3-U71-ERD-S-0004

SH NO. 524

REV. 0

of 538

Table A.2-1 Maximum Stress Ratios for Flexure and Membrane Forces: RB (Continued)

Location	Element ID	Primary Reinforcement																			
		Direction 1										Direction 2									
		In/Top					Out/Bottom					In/Top					Out/Bottom				
		NA3		DCD		Ratio (NA3/DCD)	NA3		DCD		Ratio (NA3/DCD)	NA3		DCD		Ratio (NA3/DCD)	NA3		DCD		Ratio (NA3/DCD)
σ/σ_a	Load ID	σ/σ_a	Load ID		σ/σ_a	Load ID	σ/σ_a	Load ID		σ/σ_a	Load ID	σ/σ_a	Load ID		σ/σ_a	Load ID	σ/σ_a	Load ID			
24 Basemat @ Wall Below RCCV	90140	0.500	7571	0.570	7511	0.88	0.474	7671	0.889	7721	0.53	0.383	7672	0.411	7501	0.93	0.157	7172	0.391	7143	0.40
	90182	0.244	7491	0.257	7491	0.95	0.100	7601	0.293	7601	0.34	0.181	7921	0.377	7921	0.48	0.254	9014	0.533	7941	0.48
	90111	0.237	7571	0.233	7491	1.02	0.077	7672	0.195	7603	0.40	0.141	7581	0.236	8081	0.60	0.214	7841	0.496	7841	0.43
25 Slab EL4.65m @ RCCV	93140	0.478	8514	0.491	7482	0.97	0.427	7811	0.639	7811	0.67	0.524	7941	0.450	7941	1.17	0.406	6421	0.526	6421	0.77
	93182	0.741	8514	0.690	7441	1.07	0.205	6441	0.319	7231	0.64	0.270	8511	0.375	7441	0.72	0.257	7351	0.326	7301	0.79
	93111	0.689	8514	0.612	7441	1.13	0.218	7602	0.232	7441	0.94	0.320	8514	0.410	7482	0.78	0.235	8507	0.261	6421	0.90
26 Slab EL17.5m @ RCCV	96144	0.412	8511	0.409	7482	1.01	0.600	6971	0.741	6345	0.81	0.705	8514	0.565	7482	1.25	0.757	8508	0.930	6441	0.81
	96186	0.483	8513	0.397	7133	1.22	0.442	7431	0.643	7431	0.69	0.550	8511	0.525	7482	1.05	0.256	7103	0.297	8001	0.86
	96113	0.588	8513	0.524	7482	1.12	0.428	7102	0.320	7102	1.33	0.365	7521	0.265	7521	1.38	0.440	7103	0.439	7481	1.00
27 Slab EL27.0m @ RCCV	98472	0.890	8512	0.566	6001	1.57	0.869	8512	0.450	6001	1.93	0.518	8511	0.060	6001	8.64	0.875	8512	0.440	6001	1.99
	98514	0.668	8513	0.200	6001	3.34	0.402	8513	0.260	6001	1.54	0.291	8511	0.160	6001	1.82	0.313	8514	0.030	6001	10.42
	98424	0.844	8514	0.600	6001	1.41	0.685	7501	0.000	6001	1.00	0.436	7851	0.240	6001	1.82	0.720	8514	0.150	6001	4.80
28 Pool Girder @ Storage Pool	123054	0.669	8512	0.595	6001	1.13	0.327	8507	0.010	6001	32.66	0.631	8501	0.550	6001	1.15	0.531	7481	0.040	6001	13.28
	123154	0.455	8512	0.211	6001	2.16	0.385	8514	0.040	6001	9.64	0.724	8513	0.350	6001	2.07	0.306	7431	0.070	6001	4.37
29 Pool Girder @ Cavity	123062	0.464	6971	0.212	6001	2.19	0.295	8514	0.040	6001	7.38	0.602	7421	0.050	6001	12.03	0.298	7501	0.070	6001	4.26
	123162	0.365	7461	0.201	6001	1.82	0.432	7131	0.320	6001	1.35	0.735	7481	0.290	6001	2.53	0.165	6142	0.160	6001	1.03
30 Pool Girder @ Fuel Pool	123067	0.888	8513	0.514	6001	1.73	0.805	8506	0.310	6001	2.60	0.554	6431	0.010	6001	55.40	0.725	9005	0.310	6001	2.34
	123167	0.601	8505	0.494	6001	1.22	0.772	9005	0.390	6001	1.98	0.479	6445	0.020	6001	23.97	0.676	8505	0.410	6001	1.65
31 MS Tunnel Wall and Slab	150122	0.517	2021	0.516	2021	1.00	0.064	7501	0.053	6501	1.21	0.491	2521	0.491	2521	1.00	0.072	7421	0.071	7421	1.02
	96611	0.383	7521	0.361	7521	1.06	0.155	7101	0.227	7501	0.68	0.143	7521	0.131	7521	1.09	0.155	7851	0.117	7801	1.33
	98614	0.284	7371	0.269	7341	1.05	0.058	8514	0.073	7991	0.79	0.120	7521	0.123	7521	0.97	0.498	8511	0.050	7602	9.94
32 IC/PCCS Pool Wall in NS Dir.	125051	0.544	8505	0.220	6001	2.47	0.628	8512	0.170	6001	3.70	0.748	8513	0.270	6001	2.77	0.773	8512	0.230	6001	3.36
	125151	0.520	8513	0.260	6001	2.00	0.609	8512	0.220	6001	2.77	0.610	8505	0.270	6001	2.26	0.605	8512	0.220	6001	2.75
	125055	0.380	8514	0.090	6001	4.22	0.458	8512	0.090	6001	5.09	0.408	8514	0.010	6001	40.84	0.483	8512	0.110	6001	4.39
	125155	0.377	8514	0.090	6001	4.19	0.473	8512	0.090	6001	5.25	0.276	8514	0.010	6001	27.62	0.310	8512	0.000	6001	1.00

Note *: Wall Below RCCV Direction1 : Hoop, Direction2 : Vertical
 Exterior Wall Direction1 : Horizontal, Direction2 : Vertical
 Slab Direction1 : N-S, Direction2 : E-W
 Pool Girder Direction1 : Horizontal, Direction2 : Vertical
 MS Tunnel Wall Direction1 : Horizontal, Direction2 : Vertical
 MS Tunnel Slab Direction1 : N-S, Direction2 : E-W
 σ and σ_a are calculated and allowable stress.



HITACHI

WG3-U71-ERD-S-0004

SH NO. 525

REV. 0

of 538

Table A.2-2 Maximum Stress Ratios for Membrane Compressive Forces: RB

Location	Element ID	Thickness h (m)	NA3				DCD				Ratio (NA3/DCD)					
			Load ID	Ciculated Concrete Stress (MPa)				Load ID	Ciculated Concrete Stress (MPa)				σ_x	σ_y	τ_{xy}	σ_c
				σ_x (MPa)	σ_y (MPa)	τ_{xy} (MPa)	σ_c (MPa)		σ_x (MPa)	σ_y (MPa)	τ_{xy} (MPa)	σ_c (MPa)				
18 Wall Below RCCV Bottom	6	2.0	2001	-0.782	-4.095	-0.109	-4.098	7561	-3.918	-10.104	-2.879	-11.237	0.20	0.41	0.04	0.36
	13	2.0	2001	-0.726	-3.290	0.135	-3.297	7501	-3.154	-8.716	2.071	-9.402	0.23	0.38	0.07	0.35
	24	2.0	2001	-0.609	-3.631	-0.174	-3.641	7561	-2.150	-7.952	-3.331	-9.469	0.28	0.46	0.05	0.38
19 Wall Below RCCV Mid-Height	806	2.0	2001	-0.644	-3.516	-0.150	-3.524	7561	-2.205	-8.187	-3.260	-9.620	0.29	0.43	0.05	0.37
	813	2.0	8514	-1.356	-8.182	-0.589	-8.232	7501	-2.345	-8.124	2.576	-9.106	0.58	1.01	-0.23	0.90
	824	2.0	2001	-0.975	-3.607	-0.154	-3.616	7561	-2.057	-7.647	-3.866	-9.623	0.47	0.47	0.04	0.38
20 Wall Below RCCV Top	1606	2.0	2001	-0.666	-3.213	0.125	-3.219	7501	-1.489	-6.574	3.575	-8.419	0.45	0.49	0.04	0.38
	1613	2.0	8514	1.899	-8.295	1.089	-8.410	7501	-1.255	-7.091	2.647	-8.113	-1.51	1.17	0.41	1.04
	1624	2.0	8514	2.392	-8.701	-1.389	-8.872	7561	-1.069	-6.815	-3.822	-8.723	-2.24	1.28	0.36	1.02
21 Exterior Wall @ EL-11.50 ~10.50m	20011	2.0	7501	-2.042	-3.604	-1.463	-4.482	7501	-2.017	-3.697	-5.300	-8.223	1.01	0.97	0.28	0.54
	20023	2.0	7491	-3.417	-3.098	1.686	-4.951	7491	-3.185	-4.946	1.959	-6.214	1.07	0.63	0.86	0.80
	30010	2.0	7561	-2.199	-2.171	-0.594	-2.779	7561	-2.825	-3.872	-1.958	-5.375	0.78	0.56	0.30	0.52
	30020	2.0	8511	-0.909	-2.515	-1.040	-3.026	7301	-0.861	-2.873	-0.907	-3.221	1.06	0.88	1.15	0.94
	40001	2.0	7251	-0.774	-1.862	0.866	-2.340	7301	-0.686	-3.033	0.844	-3.305	1.13	0.61	1.03	0.71
	40011	2.0	2001	-0.756	-1.676	-0.081	-1.683	7501	-2.490	-3.869	-2.216	-5.500	0.30	0.43	0.04	0.31
22 Exterior Wall @ EL4.65 ~6.60m	22011	1.5	7501	-0.914	-5.756	3.195	-7.343	7501	-1.027	-7.448	5.293	-10.428	0.89	0.77	0.60	0.70
	22023	1.5	7492	-0.563	-8.116	-4.138	-9.942	7492	-0.323	-9.243	-4.533	-11.143	1.74	0.88	0.91	0.89
	32010	1.5	7501	-0.995	-3.710	2.090	-4.845	7501	-1.143	-4.577	2.972	-6.292	0.87	0.81	0.70	0.77
	32020	1.5	7251	-0.358	-5.476	1.690	-5.984	7301	-0.178	-4.772	2.497	-5.868	2.01	1.15	0.68	1.02
	42001	1.5	7251	-0.266	-5.569	1.731	-6.084	7201	-0.164	-4.795	2.513	-5.896	1.62	1.16	0.69	1.03
	42011	1.5	7501	-1.110	-4.455	-2.491	-5.783	7501	-0.937	-4.398	-3.997	-7.022	1.18	1.01	0.62	0.82
23 Exterior Wall @ EL22.50 ~24.60m	24211	1.5	7561	-0.757	-4.344	2.536	-5.657	7561	-0.857	-4.677	3.931	-7.137	0.88	0.93	0.65	0.79
	24224	1.5	7301	-0.356	-6.929	2.634	-7.854	7301	-0.278	-6.902	2.982	-8.047	1.28	1.00	0.88	0.98
	34210	1.5	7561	-0.712	-1.899	2.346	-3.725	7561	-0.865	-1.814	2.591	-3.974	0.82	1.05	0.91	0.94
	34220	1.5	7351	0.148	-3.042	-1.481	-3.624	7301	0.157	-2.515	-1.984	-3.571	0.94	1.21	0.75	1.01
	44201	1.5	7251	0.128	-3.399	-1.736	-4.110	7561	0.140	-2.597	-2.447	-4.032	0.92	1.31	0.71	1.02

Notes: Compressive forces are negative.



HITACHI

WG3-U71-ERD-S-0004

SH NO. 526

REV. 0

of 538

Table A.2-2 Maximum Stress Ratios for Membrane Compressive Forces: RB (Continued)

Location	Element ID	Thickness h (m)	NA3						DCD						Ratio (NA3/DCD)			
			Load ID	Ciculated Concrete Stress (MPa)				Load ID	Ciculated Concrete Stress (MPa)				σ_x	σ_y	τ_{xy}	σ_c		
				σ_x (MPa)	σ_y (MPa)	τ_{xy} (MPa)	σ_c (MPa)		σ_x (MPa)	σ_y (MPa)	τ_{xy} (MPa)	σ_c (MPa)						
24 Basemat @ Wall Below RCCV	90140	4.0	7151	-1.520	-0.942	0.554	-1.855	7102	-1.073	-1.944	0.986	-2.587	1.42	0.48	0.56	0.72		
	90182	4.0	2001	-0.874	-0.671	-0.031	-0.879	7501	-2.382	-0.901	-0.414	-2.490	0.37	0.75	0.08	0.35		
	90111	4.0	2001	-1.012	-0.789	0.009	-1.013	7561	-1.296	-2.191	0.247	-2.254	0.78	0.36	0.04	0.45		
25 Slab EL4.65m @ RCCV	93140	1.0	8514	-2.967	0.452	3.622	-5.263	7482	-3.388	0.551	3.561	-5.488	0.88	0.82	1.02	0.96		
	93182	1.0	8511	1.567	-4.979	-0.427	-5.007	7421	2.108	-5.472	-0.717	-5.540	0.74	0.91	0.60	0.90		
	93111	1.0	7421	-4.428	1.759	-0.287	-4.441	7421	-4.862	2.024	-0.343	-4.879	0.91	0.87	0.84	0.91		
26 Slab EL17.5m @ RCCV	96144	1.0	8508	0.111	0.762	4.690	-4.265	7241	-0.852	0.797	4.149	-4.258	-0.13	0.96	1.13	1.00		
	96186	1.0	8514	2.343	-6.951	-2.172	-7.434	7271	2.808	-5.664	-1.755	-6.014	0.83	1.23	1.24	1.24		
	96113	1.6	6483	-6.247	1.715	-0.989	-6.368	7482	-6.240	1.993	-1.143	-6.396	1.00	0.86	0.87	1.00		
27 Slab EL27.0m @ RCCV	98472	1.5	8513	-7.205	-4.058	8.391	-14.169	7003	-7.459	-4.269	8.549	-14.560	0.97	0.95	0.98	0.97		
	98514	1.5	8511	2.676	-3.621	-1.566	-3.989	7001	2.714	-3.750	-1.635	-4.140	0.99	0.97	0.96	0.96		
	98424	2.4	8512	-12.124	0.878	-2.453	-12.572	7002	-11.003	-1.373	-3.491	-12.136	1.10	-0.64	0.70	1.04		
28 Pool Girder @ Storage Pool	123054	1.6	8512	-0.826	-9.380	1.591	-9.666	7002	-0.789	-8.983	1.450	-9.232	1.05	1.04	1.10	1.05		
	123154	1.6	8512	-1.766	-3.583	2.562	-5.393	7002	-1.752	-3.509	2.530	-5.309	1.01	1.02	1.01	1.02		
29 Pool Girder @ Cavity	123062	1.6	8513	-2.322	-5.926	-1.098	-6.235	7003	-2.351	-5.915	-1.032	-6.192	0.99	1.00	1.06	1.01		
	123162	1.6	8513	-2.134	-4.689	-3.002	-6.674	7003	-1.964	-4.725	-2.980	-6.629	1.09	0.99	1.01	1.01		
30 Pool Girder @ Fuel Pool	123067	1.6	8511	-2.683	-7.409	-4.312	-9.962	7001	-2.754	-7.355	-4.082	-9.740	0.97	1.01	1.06	1.02		
	123167	1.6	8511	-2.386	-3.236	-4.057	-6.890	7142	-2.449	-2.151	-2.916	-5.220	0.97	1.50	1.39	1.32		
31 MS Tunnel Wall and Slab	150122	1.3	2021	-0.021	-0.429	1.150	-1.393	2021	-0.020	-0.425	1.147	-1.388	1.02	1.01	1.00	1.00		
	96611	1.6	8511	-0.464	1.453	-0.052	-0.465	7421	-0.412	1.453	-0.069	-0.415	1.13	1.00	0.75	1.12		
	98614	2.4	8512	-0.752	1.072	-0.282	-0.795	7481	0.025	-0.518	0.026	-0.519	-30.60	-2.07	-10.74	1.53		
32 IC/PCCS Pool Wall in NS Dir.	125051	1.0	7501	-0.260	-2.951	-2.191	-4.177	7004	0.673	-3.220	2.227	-4.231	-0.39	0.92	-0.98	0.99		
	125151	1.0	7441	-2.048	-2.214	3.305	-5.437	7001	-1.707	-1.762	2.841	-4.576	1.20	1.26	1.16	1.19		
	125055	1.0	8513	-5.767	-0.210	-0.799	-5.879	7003	-5.873	-0.161	-0.758	-5.972	0.98	1.31	1.05	0.98		
	125155	1.0	8513	-6.767	-0.414	-0.774	-6.860	7003	-6.723	-0.380	-0.731	-6.807	1.01	1.09	1.06	1.01		

Notes: Compressive forces are negative.



HITACHI

WG3-U71-ERD-S-0004

SH NO. 527

REV. 0

of 538

Table A.2-2 Maximum Stress Ratios for Membrane Compressive Forces: RB (Continued)

Location	Element ID	Thickness h (m)	NA3			DCD			Ratio (NA3/DCD)
			Load ID	Allowable Stress σ_a (MPa)	σ_c/σ_a	Load ID	Allowable Stress σ_a (MPa)	σ_c/σ_a	
18 Wall Below RCCV Bottom	6	2.0	2001	-10.4	0.396	7561	-20.7	0.543	0.729
	13	2.0	2001	-10.4	0.319	7501	-20.7	0.454	0.701
	24	2.0	2001	-10.4	0.352	7561	-20.7	0.457	0.769
19 Wall Below RCCV Mid-Height	806	2.0	2001	-10.4	0.340	7561	-20.7	0.465	0.733
	813	2.0	8514	-25.9	0.318	7501	-20.7	0.440	0.723
	824	2.0	2001	-10.4	0.349	7561	-20.7	0.465	0.752
20 Wall Below RCCV Top	1606	2.0	2001	-10.4	0.311	7501	-20.7	0.407	0.765
	1613	2.0	8514	-25.9	0.325	7501	-20.7	0.392	0.829
	1624	2.0	8514	-25.9	0.343	7561	-20.7	0.421	0.814
21 Exterior Wall @ EL11.50 ~10.50m	20011	2.0	7501	-20.7	0.217	7501	-20.7	0.397	0.545
	20023	2.0	7491	-25.9	0.191	7491	-25.9	0.240	0.797
	30010	2.0	7561	-20.7	0.134	7561	-20.7	0.260	0.517
	30020	2.0	8511	-25.9	0.117	7301	-20.7	0.156	0.751
	40001	2.0	7251	-20.7	0.113	7301	-20.7	0.160	0.708
	40011	2.0	2001	-10.4	0.163	7501	-20.7	0.266	0.612
22 Exterior Wall @ EL4.65 ~6.60m	22011	1.5	7501	-20.7	0.355	7501	-20.7	0.504	0.704
	22023	1.5	7492	-25.9	0.384	7492	-25.9	0.431	0.892
	32010	1.5	7501	-20.7	0.234	7501	-20.7	0.304	0.770
	32020	1.5	7251	-20.7	0.289	7301	-20.7	0.283	1.020
	42001	1.5	7251	-20.7	0.294	7201	-20.7	0.285	1.032
	42011	1.5	7501	-20.7	0.279	7501	-20.7	0.339	0.824
23 Exterior Wall @ EL22.50 ~24.60m	24211	1.5	7561	-20.7	0.273	7561	-20.7	0.345	0.793
	24224	1.5	7301	-20.7	0.379	7301	-20.7	0.389	0.976
	34210	1.5	7561	-20.7	0.180	7561	-20.7	0.192	0.938
	34220	1.5	7351	-20.7	0.175	7301	-20.7	0.173	1.015
	44201	1.5	7251	-20.7	0.199	7561	-20.7	0.195	1.019

Notes: Compressive forces are negative.



Table A.2-2 Maximum Stress Ratios for Membrane Compressive Forces: RB (Continued)

Location	Element ID	Thickness h	NA3			DCD			Ratio (NA3/DCD)
			Load ID	Allowable Stress	σ_c/σ_a	Load ID	Allowable Stress	σ_c/σ_a	
24 Basemat @ Wall Below RCCV	90140	4.0	7151	-16.6	0.112	7102	-16.6	0.156	0.717
	90182	4.0	2001	-8.3	0.106	7501	-16.6	0.150	0.706
	90111	4.0	2001	-8.3	0.122	7561	-16.6	0.136	0.898
25 Slab EL4.65m @ RCCV	93140	1.0	8514	-25.9	0.203	7482	-25.9	0.212	0.959
	93182	1.0	8511	-25.9	0.193	7421	-25.9	0.214	0.904
	93111	1.0	7421	-25.9	0.172	7421	-25.9	0.189	0.910
26 Slab EL17.5m @ RCCV	96144	1.0	8508	-25.9	0.165	7241	-25.9	0.165	1.002
	96186	1.0	8514	-25.9	0.287	7271	-25.9	0.232	1.236
	96113	1.6	6483	-25.9	0.246	7482	-25.9	0.247	0.996
27 Slab EL27.0m @ RCCV	98472	1.5	8513	-25.9	0.548	7003	-25.9	0.563	0.973
	98514	1.5	8511	-25.9	0.154	7001	-25.9	0.160	0.963
	98424	2.4	8512	-25.9	0.486	7002	-25.9	0.469	1.036
28 Pool Girder @ Storage Pool	123054	1.6	8512	-25.9	0.374	7002	-25.9	0.357	1.046
	123154	1.6	8512	-25.9	0.208	7002	-25.9	0.205	1.017
29 Pool Girder @ Cavity	123062	1.6	8513	-25.9	0.241	7003	-25.9	0.239	1.008
	123162	1.6	8513	-25.9	0.258	7003	-25.9	0.256	1.008
30 Pool Girder @ Fuel Pool	123067	1.6	8511	-25.9	0.385	7001	-25.9	0.376	1.024
	123167	1.6	8511	-25.9	0.266	7001	-25.9	0.267	0.997
31 MS Tunnel Wall and Slab	150122	1.3	2021	-15.5	0.090	2021	-15.5	0.089	1.004
	98611	1.6	8511	-25.9	0.018	7421	-25.9	0.016	1.122
	98614	2.4	8512	-25.9	0.031	7481	-25.9	0.020	1.530
32 IC/PCCS Pool Wall in NS Dir.	125051	1.0	7501	-20.7	0.202	7004	-25.9	0.164	1.230
	125151	1.0	7441	-25.9	0.210	7001	-25.9	0.177	1.187
	125055	1.0	8513	-25.9	0.227	7003	-25.9	0.231	0.984
	125155	1.0	8513	-25.9	0.265	7003	-25.9	0.263	1.008

Notes: Compressive forces are negative.



HITACHI

WG3-U71-ERD-S-0004

SH NO. 529

REV. 0

of 538

Table A.2-3 Calculation Results for Maximum Transverse Shear: RB

Location	Element ID	NA3			DCD			NA3					DCD					Ratio (NA3/DCD)				
		Load ID	d (m)	pv (%)	Load ID	d (m)	pv (%)	Shear Force (MN/m)				Vu/φVn	Shear Force (MN/m)				Vu/φVn	Shear Force				Vu/φVn
								Vu	Vc	Vs	φVn		Vu	Vc	Vs	φVn		Vu	Vc	Vs	φVn	
18 Wall Below RCCV Bottom	6	7461	1.62	0.721	7642	1.59	0.721	2.16	4.96	4.84	8.33	0.259	2.72	0.00	4.73	4.02	0.677	0.79	1.00	1.02	2.07	0.38
	13	7461	1.62	0.721	7623	1.59	0.721	2.24	4.82	4.84	8.21	0.273	2.08	0.43	4.73	4.39	0.474	1.08	11.24	1.02	1.87	0.58
	24	7501	1.59	0.721	7611	1.62	0.721	2.30	4.63	4.73	7.95	0.289	0.94	0.52	4.83	4.55	0.207	2.44	8.92	0.98	1.75	1.40
19 Wall Below Below RCCV Mid-Height	806	7992	1.57	0.270	7601	1.55	0.270	0.12	0.15	1.75	1.61	0.077	0.19	0.22	1.73	1.66	0.115	0.65	0.65	1.02	0.97	0.67
	813	8514	1.57	0.270	7603	1.54	0.270	0.91	4.86	1.75	5.62	0.162	0.34	0.00	1.71	1.46	0.230	2.70	1.00	1.02	3.86	0.70
	824	8514	1.57	0.270	7601	1.54	0.270	1.02	5.00	1.75	5.74	0.177	0.19	0.22	1.72	1.65	0.114	5.38	22.52	1.02	3.47	1.55
20 Wall Below RCCV Top	1606	6421	1.57	0.540	7921	1.57	0.540	4.05	4.00	3.50	6.37	0.635	2.69	1.43	3.50	4.18	0.642	1.51	2.80	1.00	1.52	0.99
	1613	6471	1.57	0.540	7821	1.57	0.540	4.68	4.24	3.50	6.57	0.712	2.32	1.36	3.50	4.13	0.562	2.02	3.12	1.00	1.59	1.27
	1624	8507	1.57	0.540	7941	1.57	0.540	5.07	4.37	3.50	6.69	0.759	3.41	2.34	3.50	4.96	0.689	1.49	1.87	1.00	1.35	1.10
21 Exterior Wall @ EL-11.50 ~10.50m	20011	8512	1.63	0.484	7441	1.63	0.484	1.87	0.64	3.27	3.32	0.562	3.81	1.96	3.27	4.44	0.856	0.49	0.33	1.00	0.75	0.66
	20023	8514	1.58	0.484	7441	1.59	0.484	1.46	1.85	3.15	4.25	0.342	2.06	3.31	3.18	5.52	0.373	0.71	0.56	0.99	0.77	0.92
	30010	7511	1.68	0.710	7941	1.65	0.177	1.63	2.33	4.93	6.17	0.265	0.83	0.59	1.21	1.53	0.543	1.97	3.93	4.08	4.03	0.49
	30020	7511	1.69	0.710	7241	1.69	0.177	1.20	3.52	4.96	7.21	0.166	0.82	3.26	1.24	3.82	0.214	1.46	1.08	4.01	1.89	0.77
	40001	7571	1.70	0.710	7241	1.73	0.177	1.44	2.08	4.98	6.00	0.239	1.07	3.52	1.27	4.07	0.262	1.35	0.59	3.93	1.47	0.91
	40011	7501	1.69	0.710	7741	1.73	0.177	2.46	3.91	4.97	7.55	0.325	0.16	0.19	1.27	1.24	0.128	15.49	20.87	3.92	6.10	2.54
22 Exterior Wall @ EL4.65 ~6.60m	22011	8514	1.15	0.484	7441	1.19	0.484	1.00	0.00	2.31	1.96	0.513	1.11	0.00	2.38	2.02	0.549	0.90	1.00	0.97	0.97	0.93
	22023	9014	1.16	0.484	7241	1.18	0.484	0.71	1.10	2.33	2.92	0.242	0.75	3.71	2.36	5.16	0.146	0.94	0.30	0.99	0.57	1.66
	32010	8514	1.09	0.177	7441	1.24	0.177	0.36	0.00	0.80	0.68	0.524	0.33	0.00	0.91	0.77	0.424	1.09	1.00	0.88	0.88	1.24
	32020	6435	1.25	0.177	6241	1.24	0.177	0.25	0.29	0.91	1.02	0.242	0.11	0.13	0.90	0.88	0.123	2.30	2.30	1.01	1.17	1.96
	42001	7411	1.25	0.242	4021	1.19	0.242	0.84	0.85	1.25	1.79	0.468	0.18	0.21	1.19	1.19	0.150	4.71	4.06	1.06	1.51	3.13
	42011	7711	1.09	0.242	4021	1.22	0.242	0.29	0.27	1.09	1.16	0.252	0.03	0.04	1.22	1.07	0.031	8.92	6.99	0.90	1.09	8.21
23 Exterior Wall @ EL22.50 ~24.60m	24211	8511	1.09	0.968	7241	1.15	0.484	2.78	0.00	4.25	3.61	0.771	1.50	0.00	2.30	1.96	0.769	1.85	1.00	1.85	1.85	1.00
	24224	7211	1.10	0.484	7441	1.19	0.968	1.79	0.00	2.21	1.88	0.954	1.30	0.02	4.65	3.97	0.327	1.38	0.00	0.47	0.47	2.91
	34210	8512	1.09	0.177	7441	1.24	0.177	0.52	0.00	0.80	0.68	0.761	0.26	0.00	0.91	0.77	0.340	1.97	1.00	0.88	0.88	2.24
	34220	8503	1.26	0.710	6241	1.26	0.710	1.21	0.94	3.69	3.93	0.308	0.24	0.28	3.69	3.37	0.070	5.14	3.40	1.00	1.17	4.40
44201	4021	1.26	0.968	4021	1.26	0.968	2.40	0.95	4.89	4.96	0.483	2.41	0.95	4.89	4.96	0.485	1.00	1.00	1.00	1.00	1.00	
24 Basemat @ Wall Below RCCV	90140	7571	3.53	0.801	7441	3.53	0.801	6.36	4.46	11.69	13.73	0.463	10.74	7.16	11.69	16.03	0.670	0.59	0.62	1.00	0.86	0.69
	90182	7331	3.51	0.801	7441	3.51	0.801	5.34	5.96	11.63	14.95	0.357	7.41	6.13	11.64	15.10	0.491	0.72	0.97	1.00	0.99	0.73
	90111	8514	3.55	0.801	7941	3.37	0.801	5.12	6.17	11.76	15.24	0.336	2.64	1.67	11.15	10.90	0.242	1.94	3.70	1.05	1.40	1.39
25 Slab EL4.65m @ RCCV	93140	8514	0.80	0.500	7441	1.00	0.500	0.30	0.22	1.65	1.59	0.192	0.37	0.27	2.07	1.99	0.184	0.83	0.81	0.80	0.80	1.04
	93182	8514	0.80	0.500	7441	1.00	0.500	2.30	1.36	1.65	2.56	0.899	2.54	1.57	2.07	3.09	0.822	0.90	0.86	0.80	0.83	1.09
	93111	8514	0.80	0.500	7441	1.00	0.500	1.97	1.24	1.65	2.46	0.800	1.84	1.57	2.07	3.09	0.594	1.07	0.79	0.80	0.80	1.35
26 Slab EL17.5m @ RCCV	96144	7103	0.80	0.500	7741	0.80	0.500	0.32	0.82	1.65	2.10	0.153	0.07	0.08	1.65	1.47	0.046	4.73	10.18	1.00	1.43	3.31
	96186	8511	0.80	0.500	7441	1.00	0.500	1.41	2.18	1.65	3.25	0.432	1.15	2.68	2.07	4.03	0.286	1.22	0.81	0.80	0.81	1.51
	96113	7492	1.34	0.500	4021	1.34	0.500	1.75	1.59	2.76	3.69	0.474	0.82	1.54	2.76	3.66	0.225	2.13	1.03	1.00	1.01	2.11
27 Slab EL27.0m @ RCCV	98472	8513	1.21	0.968	7504	1.21	0.968	3.50	4.56	4.73	7.90	0.443	1.41	0.58	4.72	4.50	0.314	2.48	7.87	1.00	1.76	1.41
	98514	8514	1.21	0.968	7004	1.21	0.968	3.49	1.88	4.72	5.61	0.623	3.50	1.95	4.72	5.67	0.617	1.00	0.96	1.00	0.99	1.01
	98424	8512	1.95	0.968	7002	2.11	0.968	10.86	7.00	7.62	12.42	0.874	10.27	7.08	8.23	13.01	0.789	1.06	0.99	0.93	0.95	1.11



HITACHI

WG3-U71-ERD-S-0004

SH NO. 530

REV. 0

of 538

Table A.2-3 Calculation Results for Maximum Transverse Shear: RB (Continued)

28 Pool Girder @ Storage Pool	123054	9011	1.25	0.484	7501	1.25	0.484	1.25	1.35	2.50	3.28	0.382	1.20	1.41	2.50	3.32	0.362	1.04	0.96	1.00	0.99	1.06
	123154	8503	1.25	0.484	6002	1.25	0.484	0.94	1.40	2.50	3.32	0.284	0.94	1.38	2.50	3.30	0.285	1.00	1.01	1.00	1.01	1.00
29 Pool Girder @ Cavity	123062	7361	1.25	0.242	7504	1.22	0.242	0.43	1.30	1.25	2.17	0.200	0.12	0.14	1.22	1.15	0.101	3.61	9.30	1.02	1.88	1.98
	123162	7331	1.23	0.242	6004	1.23	0.242	0.30	0.33	1.23	1.32	0.224	0.05	0.06	1.23	1.10	0.044	5.90	5.45	1.00	1.20	5.08
30 Pool Girder @ Fuel Pool	123067	7441	1.28	0.484	7502	1.24	0.484	1.02	4.00	2.57	5.58	0.182	0.10	0.12	2.49	2.21	0.046	10.17	33.35	1.03	2.53	3.96
	123167	8513	1.24	0.484	6001	1.27	0.484	0.75	0.98	2.48	2.94	0.254	0.21	0.25	2.55	2.38	0.089	3.55	3.93	0.97	1.24	2.85
31 MS Tunnel Wall and Slab	150122	8512	1.06	0.177	7741	1.04	0.177	0.53	0.73	0.78	1.28	0.416	0.04	0.04	0.76	0.68	0.053	14.81	17.45	1.02	1.87	7.92
	96611	8514	1.34	0.500	7241	1.34	0.500	0.62	1.65	2.76	3.75	0.166	0.47	1.60	2.76	3.70	0.126	1.33	1.03	1.00	1.01	1.32
	98614	8511	1.95	0.500	7941	2.14	0.500	1.44	3.51	4.04	6.41	0.224	0.23	0.27	4.42	3.99	0.058	6.18	12.84	0.91	1.61	3.84
32 IC/PCCS Pool Wall in NS Direction	125051	8512	0.81	0.250	7004	0.81	0.250	0.28	0.82	0.83	1.41	0.201	0.12	0.14	0.84	0.83	0.139	2.35	5.86	0.99	1.69	1.44
	125151	8513	0.82	0.250	6001	0.80	0.250	0.24	0.49	0.85	1.13	0.209	0.12	0.14	0.83	0.83	0.148	1.98	3.47	1.02	1.37	1.42
	125055	8514	0.80	0.250	7502	0.79	0.250	0.34	0.65	0.83	1.25	0.275	0.08	0.10	0.82	0.78	0.105	4.30	6.48	1.01	1.61	2.62
	125155	8512	0.79	0.250	6004	0.83	0.250	0.29	0.71	0.82	1.30	0.221	0.05	0.06	0.86	0.78	0.061	5.75	11.88	0.95	1.67	3.62



HITACHI

WG3-U71-ERD-S-0004	SH NO. 531
REV. 0	of 538

APPENDIX B

IN-PLANE SHEAR CHECK FOR RB ACCORDING TO ACI349-01



Table of Contents

B.1 SCOPE533
B.2 IN-PLANE SHEAR CHECK533
B.3 CONCLUSION.....533

List of Tables

Table B-1 Maximum Stress Ratios for In-Plane Shear Check534

List of Figures

None

**B.1 SCOPE**

This appendix describes In-plane Shear Check for RB according to ACI349-01.

B.2 IN-PLANE SHEAR CHECK

According to ACI 394-01 Section 21.6.5.2, the maximum shear strength of a horizontal wall segment per unit length is calculated as follows.

$$V_n = (2\sqrt{f'_c} + \rho_n f_y)h \quad (\text{lb/in})$$

Where, h is wall thickness.

Shear strength calculated above shall not be taken greater than the following equation specified in ACI 394-01 Section 21.6.5.7.

$$V_{n_{\max}} = 10\sqrt{f'_c}h \quad (\text{lb/in})$$

The reduction of thermal stresses due to the decreased stiffness of a cracked concrete section is considered.

B.3 CONCLUSION

The results of in-plane shear check are shown in Table B-1. It is confirmed that the combined forces N_{xy} are lower than the allowable shear forces evaluated above.



HITACHI

WG3-U71-ERD-S-0004 SH NO. 534

REV. 0

of 538

Table B-1 Maximum Stress Ratios for In-Plane Shear Check

Location	Element ID	Load Case	Nxy (MN/m)	Thickness t (m)	Primary Reinforce-ment Ratio	Allowable Shear Strength $\phi V_n = \phi 10 t f_c^{0.5}$ (MN/m)	$N_{xy}/\phi V_n$
18 Wall Below RCCV Bottom	6	8514	2.065	2.0	2.150 %	8.288	0.249
	13	7482	1.586	2.0	2.150 %	8.288	0.191
	24	7491	1.463	2.0	2.150 %	8.288	0.177
19 Wall Below RCCV Mid-Height	806	7251	1.458	2.0	2.150 %	8.288	0.176
	813	7271	1.340	2.0	2.150 %	8.288	0.162
	824	8512	1.916	2.0	2.150 %	8.288	0.231
20 Wall Below RCCV Top	1606	7492	2.915	2.0	2.150 %	8.288	0.352
	1613	7491	2.410	2.0	2.150 %	8.288	0.291
	1624	7492	2.821	2.0	2.150 %	8.288	0.340
21 Exterior Wall @ EL-11.50 ~10.50m	20011	7251	2.974	2.0	2.264 %	8.288	0.359
	20023	7491	3.372	2.0	2.264 %	8.288	0.407
	30010	8511	1.329	2.0	2.768 %	8.288	0.160
	30020	8511	2.079	2.0	2.768 %	8.288	0.251
	40001	7461	2.051	2.0	2.768 %	8.288	0.247
22 Exterior Wall @ EL4.65 ~6.60m	40011	7201	1.359	2.0	2.768 %	8.288	0.164
	22011	7511	4.965	1.5	2.348 %	6.216	0.799
	22023	7492	6.207	1.5	2.348 %	6.216	0.999
	32010	7161	3.294	1.5	2.683 %	6.216	0.530
	32020	7123	3.042	1.5	2.012 %	6.216	0.489
23 Exterior Wall @ EL22.50 ~24.60m	42001	7511	2.990	1.5	2.348 %	6.216	0.481
	42011	7163	3.797	1.5	2.683 %	6.216	0.611
	24211	7571	3.818	1.5	2.348 %	6.216	0.614
	24224	7482	4.601	1.5	2.348 %	6.216	0.740
	34210	7211	3.545	1.5	2.683 %	6.216	0.570
32 IC/PCCS Pool Wall in NS Dir.	34220	7482	2.924	1.5	2.012 %	6.216	0.470
	44201	7561	2.791	1.5	2.348 %	6.216	0.449
	125051	8514	2.557	1.0	1.761 %	4.144	0.617
	125151	7441	3.305	1.0	1.761 %	4.144	0.798
	125055	7461	0.585	1.0	1.761 %	4.144	0.141
	125155	7411	0.495	1.0	1.761 %	4.144	0.119



HITACHI

WG3-U71-ERD-S-0004 SH NO. 535

REV. 0

of 538

APPENDIX C

COMPRESSION LIMIT CHECK FOR RB ACCORDING TO ACI349-01



Table of Contents

C.1 SCOPE537
C.2 MEMBRANE COMPRESSIVE FORCE CHECK537
C.3 CONCLUSION.....537

List of Tables

Table C-1 Membrane Compressive Stress Check According to ACI349-01538

List of Figures

None

**C.1 SCOPE**

This appendix describes Membrane Compressive Force Check for RB according to ACI349-01.

C.2 MEMBRANE COMPRESSIVE FORCE CHECK

According to ACI 394-01 Section 10.3.5.2, design axial load strength of compression members shall not be taken greater than the following:

$$\phi P_n(\text{max}) = 0.80\phi \left[0.85 f'_c (A_g - A_{st}) + f_y A_{st} \right]$$

Where, A_g and A_{st} are gross area and total cross-sectional area of reinforcement of section.

C.3 CONCLUSION

The results of compression force check are shown in Table C-1. It is confirmed that the calculated compression force are less than the allowable compression force evaluated based on the above strength.



HITACHI

WG3-U71-ERD-S-0004 SH NO. 538

REV. 0

of 538

Table C-1 Membrane Compressive Stress Check According to ACI349-01

Location	Element ID	Load ID	Section Forces (MN/m)			Thickness h (m)	Culculated Concrete Stress (MPa)				Allowable Stress σ_a (MPa)	σ_c/σ_a
			Nx	Ny	Nxy		σ_x	σ_y	τ_{xy}	σ_c		
18 Wall Below RCCV Bottom	6	7511	-9.007	-15.344	1.483	2.0	-4.503	-7.672	0.742	-7.837	-21.0	0.372
	13	8514	-4.543	-16.272	-1.536	2.0	-2.272	-8.136	-0.768	-8.235	-21.0	0.391
	24	8514	-3.941	-17.188	1.318	2.0	-1.971	-8.594	0.659	-8.659	-21.0	0.411
19 Wall Below RCCV Mid-Height	806	8514	2.754	-14.914	-1.406	2.0	1.377	-7.457	-0.703	-7.513	-21.0	0.357
	813	8514	-2.711	-16.363	-1.177	2.0	-1.356	-8.182	-0.589	-8.232	-21.0	0.391
	824	8514	-3.317	-17.222	1.914	2.0	-1.658	-8.611	0.957	-8.740	-21.0	0.415
20 Wall Below RCCV Top	1606	8514	4.675	-14.954	-2.829	2.0	2.337	-7.477	-1.414	-7.677	-21.0	0.365
	1613	8514	3.797	-16.590	2.179	2.0	1.899	-8.295	1.089	-8.410	-21.0	0.400
	1624	8514	4.784	-17.402	-2.777	2.0	2.392	-8.701	-1.389	-8.872	-21.0	0.422
21 Exterior Wall @ EL-11.50 ~10.50m	20011	7571	-8.686	-6.792	-2.505	2.0	-4.343	-3.396	-1.252	-5.209	-21.3	0.245
	20023	7491	-6.833	-6.195	3.372	2.0	-3.417	-3.098	1.686	-4.951	-21.3	0.233
	30010	7561	-4.398	-4.341	-1.189	2.0	-2.199	-2.171	-0.594	-2.779	-22.4	0.124
	30020	8511	-1.819	-5.030	-2.079	2.0	-0.909	-2.515	-1.040	-3.026	-22.4	0.135
	40001	8511	-1.600	-4.909	1.906	2.0	-0.800	-2.455	0.953	-2.889	-22.4	0.129
	40011	7501	-2.912	-5.665	-1.326	2.0	-1.456	-2.833	-0.663	-3.100	-22.4	0.139
22 Exterior Wall @ EL4.65 ~6.60m	22011	7511	-1.362	-9.224	4.965	1.5	-0.908	-6.149	3.310	-7.750	-21.5	0.361
	22023	7492	-0.844	-12.174	-6.207	1.5	-0.563	-8.116	-4.138	-9.942	-21.5	0.463
	32010	7501	-1.492	-5.565	3.134	1.5	-0.995	-3.710	2.090	-4.845	-22.2	0.218
	32020	7251	-0.538	-8.214	2.536	1.5	-0.358	-5.476	1.690	-5.984	-20.8	0.288
	42001	7251	-0.399	-8.353	2.597	1.5	-0.266	-5.569	1.731	-6.084	-21.5	0.283
	42011	7501	-1.665	-6.683	-3.737	1.5	-1.110	-4.455	-2.491	-5.783	-22.2	0.261
23 Exterior Wall @ EL22.50 ~24.60m	24211	7561	-1.136	-6.516	3.804	1.5	-0.757	-4.344	2.536	-5.657	-21.5	0.263
	24224	7301	-0.534	-10.393	3.951	1.5	-0.356	-6.929	2.634	-7.854	-21.5	0.366
	34210	7561	-1.067	-2.848	3.519	1.5	-0.712	-1.899	2.346	-3.725	-22.2	0.168
	34220	7351	0.222	-4.563	-2.222	1.5	0.148	-3.042	-1.481	-3.624	-20.8	0.175
	44201	7251	0.193	-5.099	-2.604	1.5	0.128	-3.399	-1.736	-4.110	-21.5	0.191
24 Basemat @ Wall Below RCCV	90140	7471	-5.494	-2.575	3.677	4.0	-1.374	-0.644	0.919	-1.998	-15.4	0.130
	90182	7501	-5.535	-2.994	-1.500	4.0	-1.384	-0.748	-0.375	-1.558	-15.4	0.101
	90111	2500	-6.661	-4.652	0.034	4.0	-1.665	-1.163	0.009	-1.665	-15.4	0.108
25 Slab EL4.65m @ RCCV	93140	8514	-2.967	0.452	3.622	1.0	-2.967	0.452	3.622	-5.263	-20.8	0.254
	93182	8511	1.567	-4.979	-0.427	1.0	1.567	-4.979	-0.427	-5.007	-20.8	0.241
	93111	7421	-4.428	1.759	-0.287	1.0	-4.428	1.759	-0.287	-4.441	-20.8	0.214
26 Slab EL17.5m @ RCCV	96144	8508	0.111	0.762	4.690	1.0	0.111	0.762	4.690	-4.265	-20.8	0.206
	96186	8514	2.343	-6.951	-2.172	1.0	2.343	-6.951	-2.172	-7.434	-20.8	0.358
	96113	6483	-9.995	2.744	-1.583	1.6	-6.247	1.715	-0.989	-6.368	-19.8	0.321
27 Slab EL27.0m @ RCCV	98472	8513	-10.808	-6.087	12.587	1.5	-7.205	-4.058	8.391	-14.169	-24.4	0.582
	98514	8511	4.015	-5.431	-2.348	1.5	2.676	-3.621	-1.566	-3.989	-24.4	0.164
	98424	8512	-29.098	2.108	-5.888	2.4	-12.124	0.878	-2.453	-12.572	-21.4	0.588
28 Pool Girder @ Storage Pool	123054	8512	-1.321	-15.008	2.545	1.6	-0.826	-9.380	1.591	-9.666	-20.5	0.472
	123154	8512	-2.825	-5.733	4.099	1.6	-1.766	-3.583	2.562	-5.393	-20.5	0.263
29 Pool Girder @ Cavity	123062	8513	-3.715	-9.482	-1.757	1.6	-2.322	-5.926	-1.098	-6.235	-20.5	0.304
	123162	8513	-3.415	-7.503	-4.804	1.6	-2.134	-4.689	-3.002	-6.674	-20.5	0.326
30 Pool Girder @ Fuel Pool	123067	8511	-4.292	-11.854	-6.899	1.6	-2.683	-7.409	-4.312	-9.962	-21.2	0.471
	123167	8511	-3.818	-5.177	-6.491	1.6	-2.386	-3.236	-4.057	-6.890	-21.2	0.326
31 MS Tunnel Wall and Slab	150122	7421	0.068	-1.290	1.926	1.3	0.053	-0.992	1.482	-2.041	-20.2	0.101
	96611	8511	-0.742	2.325	-0.083	1.6	-0.464	1.453	-0.052	-0.465	-19.8	0.023
	98614	8512	-1.805	2.572	-0.676	2.4	-0.752	1.072	-0.282	-0.795	-19.6	0.041
32 IC/PCCS Pool Wall in NS Dir.	125051	7521	-0.522	-3.605	-2.459	1.0	-0.522	-3.605	-2.459	-4.966	-18.0	0.275
	125151	7441	-2.048	-2.214	3.305	1.0	-2.048	-2.214	3.305	-5.437	-18.0	0.301
	125055	8513	-5.767	-0.210	-0.799	1.0	-5.767	-0.210	-0.799	-5.879	-18.0	0.326
	125155	8513	-6.767	-0.414	-0.774	1.0	-6.767	-0.414	-0.774	-6.860	-18.0	0.380