

# **Certificate of Approval of Package Design for the Carriage of Radioactive Materials**

**THIS IS TO CERTIFY** that the National Nuclear Safety Administration being, for the purposes of the Regulations of the International Atomic Energy Agency, the Competent Authority of the People's Republic of China in respect of inland surface, sea and air transport, have approved the Package design as specified in section 1 of this certificate, as applied for by China Research Institute of Radio Protection (see section 6)

as Type B(U)

by All modes [See Section 1.2(d)]

Packaging identification: SY-I (A)

Packages manufactured to this design meet the requirements of the regulations and codes on page 2, relevant to the mode of transport, subject to the following general condition and to the conditions in the succeeding pages of this certificate.

In the event of any alteration in the composition of the package, the package design, the quality assurance programme(s) associated with the package or in any of the facts stated in the application for approval, this certificate will cease to have effect unless the Competent Authority is notified of the alteration and the Competent Authority confirms the certificate notwithstanding the alteration.

**Expiry Date:** This certificate supersedes any other previous issues and is valid until the end of September 2019 (see section 6)

## **COMPETENT AUTHORITY IDENTIFICATION MARK:**

**CN/045/B(U)-96(NNSA)**

**This certificate does not relieve the consignor from compliance with any requirement of the government of any country or into which the package will be transported.**

## REGULATIONS AND CODES OF PRACTICE GOVERNING THE TRANSPORT OF RADIOACTIVE MATERIALS

### **INTERNATIONAL**

#### International Atomic Energy Agency (IAEA)

TS-R-1 Regulations for the Safe Transport of Radioactive Materials 2005 Edition.

#### International Maritime Organization (IMO)

International Maritime Dangerous Goods (IMDG) Code Amendment 33-06 or Amendment 34-08.

#### International Civil Aviation Organization (ICAO)

Technical Instructions for the Safe Transport of Dangerous Goods by Air 2007-2008 Edition.

#### United Nations Economic Commission for Europe (UNECE)

European Agreement concerning the International Carriage of Dangerous Goods by Road (ADR) 2007 Edition.

#### Intergovernmental Organization for International Carriage by Rail (OTIF)

Convention concerning International Carriage by Rail (COTIF) Appendix C. Regulations concerning the International Carriage of Dangerous Goods by Rail (RID) 2007 Edition.

### **PEOPLE'S REPUBLIC OF CHINA**

For road, rail, sea and air, the People's Republic of China Regulations on Radioactive Goods Transportation Safety Administration

GB11806-2004 Regulations for the safe transport of radioactive material

(IAEA Safety Standards Series No. TS-R-1, Regulations for the Transport of Radioactive Material, 1996 Edition (As Amended 2003), IDT )

## 1. PACKAGE DESIGN SPECIFICATION

The Package Design Specification shall be in accordance with the China Research Institute of Radio Protection Safety Analysis Report reference SY-I (A) Edition B dated April 2014, and modifications to the package design approved by the authority named on page 1 of this certificate under the established modifications procedure.

### 1.1 Specification of Design

| Design No. | Title (number of components)                              | Drawing/Drawing List | Issue |
|------------|---|----------------------|-------|
| 045        | Outer – Pallet Cage (one)                                 | ZYRQ000              |       |
| Capsules   | Inner – Basket and any IAEA Special Form Material Capsule |                      |       |

### 1.2 Authorized Contents

- a) Encapsulated solid radionuclides in metallic or chloride form as detailed in Section 1.2(c) below, with maximum content weight of 30kg.
- b) Any of the radionuclides listed below with the maximum activity, as listed, or mixtures of these radionuclides such that sum of the proportions of the activities does not exceed 1.0.

| Radionuclide     | Physical State     | Chemical Composition or State | Maximum Activity |
|------------------|--------------------|-------------------------------|------------------|
| $^{60}\text{Co}$ | Solid-Special Form | Metal                         | 925TBq(25kCi)    |

- c) The total rate of heat generation shall not exceed 0.39 kW.
- d) The carriage of  $^{60}\text{Co}$  by air with an activity above 1.2PBq and up to the maximum specified above is only allowed with permission from the air transport authority of each national air space entered or transited. In the People's Republic of China, this is the Civil Aviation Administration of China (CAAC).

### 1.3 Package Dimensions and Weights

- a) Nominal Dimensions:

1141mm × 994mm × 1206mm (see section 5 for package illustration)

- b) Maximum authorized gross weight: 3650 kg

## 2. USE OF PACKAGE

### 2.1 Use of packaging

- a) The packaging shall be used, handled and maintained in accordance to China Research Institute of Radio Protection Document: Safety Analysis Report for the Design Scheme of SY-I (A) Packed Goods.

### 2.2 Supplementary Operational Controls

- a) The package shall not be sheeted over or over-stowed by loose cargo

### 2.3 Actions prior to shipment

- a) Administrative controls shall ensure that the contents are in accordance with section 1 of this certificate, and that the consignor and consignee hold a copy of the instructions on the use of the packaging.
- b) The container should be operated by personnel suitable trained in the relevant operating procedures.
- c) When loaded with more than 925TBq(25kCi)  $^{60}\text{Co}$ , the SY-I (A) must be transported under “Exclusive Use” conditions.

### 2.4 Emergency Arrangements

- a) Before shipment takes place, the consignor shall have drawn up suitable emergency plans, copies of which shall be supplied to the PRC Competent Authority on demand.
- b) If the consignor’s own, or other approved emergency plans cannot be initiated, for any reason, then the police shall be informed immediately and in the PRC, requested to call the local NNSA (National Nuclear Safety Administration) establishment.

### 2.5 Ambient temperature range for package design

- a) -40°C to +55°C

### **3. QUALITY ASSURANCE**

3.1 Quality assurance programs applicable to this design are:

- a) China Research Institute of Radio Protection's Quality Assurance Manual(GB/T19001-2008)
- b) Any other quality assurance programs associated with the design, manufacture, testing, documentation, use, maintenance and inspection, and for transport and in-transit storage operations, that also comply with national or international standards for quality assurance which are acceptable to the authority, named on page 1 of this certificate.

3.2 No alterations shall be made to the quality assurance programs associated with this design and approved by the authority named on page 1 of this certificate unless that alteration has the prior approval of said authority, or it falls within the agreed change control procedures of that program.

3.3 No quality assurance program shall be used at any stage of the design, manufacture, testing, documentation, use, maintenance and inspection, and for transport and in-transit storage operations, unless said program forms part of or is the quality assurance program approved by the authority named on page 1 of this approval certificate.

### **4. ADMINISTRATIVE INFORMATION**

4.1 Other related certificates (alternative radioactive contents)

This certificate forms the base approval of this design. No other related PRC certificates based on the SY-I (A) exist at the time of compilation of this design approval certificate.

## 5. PACKAGE ILLUSTRATION

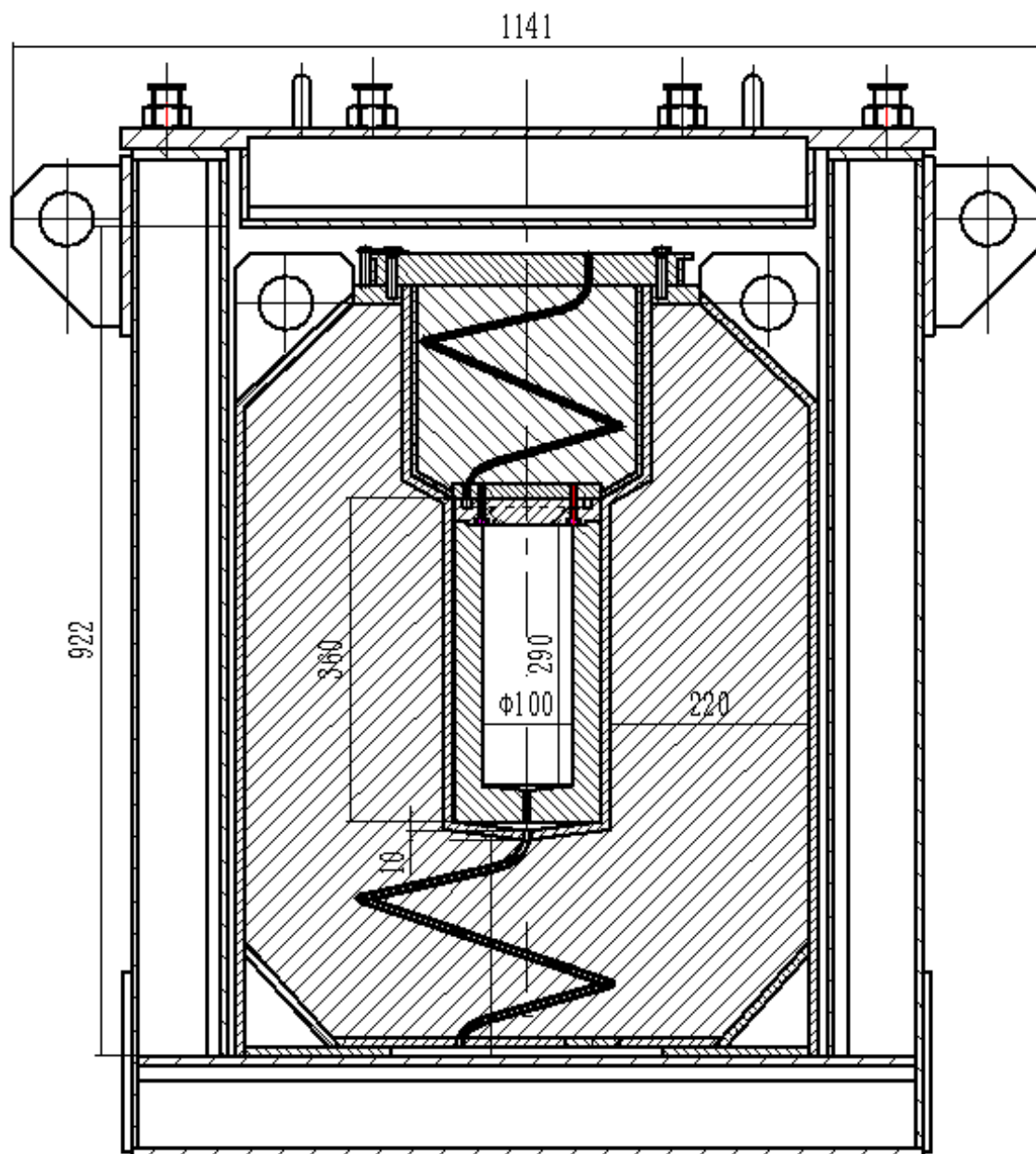

## 6. CERTIFICATE STATUS

Design Approval issued to:

China Research Institute of Radio Protection  
No. 102, Xuefu Street  
Taiyuan City  
Shanxi, 030006

| Issue No. | Date of Issue     | Date of Expiry    | Reason for Revision |
|-----------|-------------------|-------------------|---------------------|
| 1         | 25 September 2014 | 30 September 2019 | N/A                 |
| 2         |                   |                   |                     |
| 3         |                   |                   |                     |
| 4         |                   |                   |                     |
| 5         |                   |                   |                     |