

Response to Action Item 3-81 Section 3.7.2

SEB Issue List Regarding for APR1400 DCD Section 3.7.2 (Including Associated Technical Reports)

Issue #1 (AI 3-81.1)

The staff did not find a description in APR1400-E-S-NR-14002-P of how the ANSYS model was converted to the SASSI model. Specifically, the staff did not find a discussion of whether or not the conversion from ANSYS format to SASSI format was performed with the ACS SASSI translator. Please clarify how the ANSYS to SASSI conversion was performed.

Response

The response will be provided during the face to face meeting on October 5th & 6th.

Response to Action Item 3-81 Section 3.7.2

SEB Issue List Regarding for APR1400 DCD Section 3.7.2 (Including Associated Technical Reports)

Issue #2 (AI 3-81.2)

DCD Section 3.7.2.3.3 includes a description of masses that are assumed to contribute to the inertial forces in the seismic analyses. However this section did not specify the magnitude of such masses. For example, based on the description in DCD Section 3.7.2.3.3, it could be inferred that 100% of the live load is used in the seismic load case. The staff finds that Section 3.2.5 and Table 4-7 in APR1400-E-S-NR-14002-P, for the RCB and AB, respectively, provide the magnitude of the masses described in DCD Section 3.7.2.3.3. This Section of the DCD should be made consistent with the description of the masses included in the SSI analyses in report 14002.

Response

The response will be provided during the face to face meeting on October 5th & 6th.

Response to Action Item 3-81 Section 3.7.2

SEB Issue List Regarding for APR1400 DCD Section 3.7.2 (Including Associated Technical Reports)

Issue #3 (AI 3-81.3)

APR1400-E-S-NR-14002-P describes the mesh refinement for the ANSYS fine and coarse models. Regarding the ANSYS fine model, was the mesh for floor slabs and wall panels sufficiently refined to accurately capture the fundamental local out-of-plane vibration mode? How was this confirmed?

Response

The response will be provided during the face to face meeting on October 5th & 6th.

Response to Action Item 3-81 Section 3.7.2

SEB Issue List Regarding for APR1400 DCD Section 3.7.2 (Including Associated Technical Reports)

Issue #4 (AI 3-81.4)

DCD Section 3.7.2.10 states that accidental torsion is considered in the two horizontal directions. Please clarify how are the accidental torsional effects combined with the computed seismic response?

Response

The accidental torsional moments are calculated by multiplying the maximum seismic story shear forces (DCD Tier 2, Table 3.7-22 & 25) of each floor by 5 percent of the maximum building dimension at that floor elevation. The forces are applied in the direction perpendicular to the direction of the shear force considered.

These accidental torsional moments (in the clockwise and counter-clockwise directions), as calculated, are applied at the mass center of each floor with the SSE loads in the static finite element structural model (DCD Tier 2, Section 3.8.4.3.4).

Accidental Torsion is defined as;

$$T = F_x \times e_y + F_y \times e_x$$

T : Torsional moment for each level

F_x : E-W directional story shear force for each level

e_y : 5% of the maximum N-S directional building dimensions at each Level

F_y : N-S directional story shear force for each level

e_x : 5% of the maximum E-W directional building dimensions at each Level

For example, the accidental torsion at EL. 213.5' in the Auxiliary Building, is calculated as follows:

$$T = 5,425 \text{ kips (Table 3.7-22)} \times 7.125 \text{ ft (5\% of 142.5')} + 7,174 \text{ kips (Table 3.7-22)} \times 7.825 \text{ ft (5\% of 156.5')} = 94,789 \text{ kips-ft}$$

Impact on DCD

There is no impact on the DCD

Response to Action Item 3-81 Section 3.7.2

SEB Issue List Regarding for APR1400 DCD Section 3.7.2 (Including Associated Technical Reports)

Impact on PRA

There is no impact on the PRA

Impact on Technical Specifications

There is no impact on the Technical Specifications

Impact on Technical/Topical/Environmental Reports

There is no impact on any Technical, Topical, or Environmental Report

Response to Action Item 3-81 Section 3.7.2

SEB Issue List Regarding for APR1400 DCD Section 3.7.2 (Including Associated Technical Reports)

Issue #5 (AI 3-81.5)

In section 4.2.6 of APR1400-E-S-NR-14002-P, the applicant described a study to identify any property adjustments that are needed in floor panels in the AB coarse model to obtain the same flexibility as those in the fine model. However the staff did not find such considerations for walls. Please clarify whether the flexibility of wall panels has been evaluated and describe respective property adjustments as applicable.

Response

The response will be provided during the face to face meeting on October 5th & 6th.

Response to Action Item 3-81 Section 3.7.2

SEB Issue List Regarding for APR1400 DCD Section 3.7.2 (Including Associated Technical Reports)

Issue #6 (AI 3-81.6)

The maximum response accelerations provided in the DCD for the RCB are different from those provided in Appendix F of APR1400-E-S-NR-14003-P. Please clarify the difference between both sets of results and correct any “inconsistencies,” as necessary.

Response

The maximum response accelerations provided in technical report APR1400-E-S-NR-14003-P are correct. The DCD will be revised to be consistent with the report.

The maximum response acceleration values are obtained by using the maximum g values in the response acceleration time histories from the SASSI analysis.

Impact on DCD

DCD Table 3.7-14 & 17 will be revised as indicated in the attached markup.

Impact on PRA

There is no impact on the PRA

Impact on Technical Specifications

There is no impact on the Technical Specifications

Impact on Technical/Topical/Environmental Reports

There is no impact on any Technical, Topical, or Environmental Report

APR1400 DCD TIER 2

Table 3.7-14

Maximum Response Accelerations of Reactor Containment Building
Containment Structure

Maximum Response Accelerations of Reactor Containment Building (g)				
Structure	Elevation (ft)	Direction		
		X	Y	Z
Containment Structure	78	0.386	0.368	0.402
	90	0.411	0.403	0.408
	104	0.466	0.483	0.418
	118	0.507	0.551	0.441
	124	0.542	0.569	0.458
	132	0.579	0.606	0.484
	160	0.731	0.686	0.619
	180	0.834	0.783	0.703
	196	0.904	0.838	0.768
	216	0.957	0.918	0.835
	241	1.110	1.033	0.917
	255	1.221	1.126	0.957
	275	1.219	1.255	1.006
	302	1.379	1.413	1.133
	328	1.521	1.534	1.336
332	1.538	1.548	1.363	

APR1400 DCD TIER 2

Table 3.7-14

**Maximum Response Accelerations of Reactor Containment Building
Containment Structure**

Maximum Response Accelerations of Reactor Containment Building (g)				
Structure	Elevation (ft)	Direction		
		X	Y	Z
Containment Structure	78	0.353	0.396	0.398
	90	0.443	0.443	0.416
	104	0.588	0.581	0.452
	118	0.719	0.682	0.495
	124	0.761	0.705	0.525
	132	0.746	0.721	0.563
	160	0.807	0.805	0.692
	180	0.943	0.879	0.776
	196	1.026	0.983	0.844
	216	1.061	1.160	0.926
	241	1.228	1.439	1.023
	255	1.316	1.484	1.071
	275	1.406	1.551	1.127
	302	1.545	1.769	1.272
	328	1.686	1.954	1.457
332	1.700	1.963	1.529	

APR1400 DCD TIER 2

Table 3.7-17

Maximum Response Accelerations of Reactor Containment Building
Internal Structure

Maximum Response Accelerations of Internal Structure (g)				
Structure	Elevation (ft)	Direction		
		X	Y	Z
Primary Shield Wall	66	0.396	0.354	0.418
	78	0.424	0.360	0.419
	100	0.476	0.378	0.442
	107	0.484	0.386	0.485
	114	0.505	0.423	0.499
	130	0.510	0.471	0.509
	137	0.539	0.546	0.538
	156	0.897	0.964	0.814
	191a	1.031	4.531	0.677
	191b	1.314	1.617	0.856
Secondary Shield Wall	78	0.407	0.363	0.430
	100a	0.475	0.403	0.465
	100b	0.470	0.420	0.393
	107	0.507	0.423	0.503
	114	0.545	0.484	0.541
	130	0.634	0.658	0.625
	137	0.678	0.721	0.643
	156	0.937	1.022	0.753
	191	2.060	4.475	0.918
Slabs	66	-	-	0.381
	100	-	-	0.800
	107	-	-	0.452
	111	-	-	0.858
	114	-	-	0.780
	125	-	-	0.768

191a: Primary shield wall top

191b: Pressurizer room corners

100a: Secondary shield wall interface with concrete pedestal top

100b: In-containment refueling water storage tank walls

APR1400 DCD TIER 2

Table 3.7-17

**Maximum Response Accelerations of Reactor Containment Building
Internal Structure**

Maximum Response Accelerations of Internal Structure (g)				
Structure	Elevation (ft)	Direction		
		X	Y	Z
Primary Shield Wall	66	0.333	0.367	0.392
	78	0.360	0.412	0.407
	100	0.413	0.447	0.466
	107	0.433	0.441	0.519
	114	0.504	0.467	0.544
	130	0.488	0.455	0.561
	137	0.539	0.518	0.600
	156	1.011	0.993	1.019
	191a	1.218	4.937	0.880
	191b	1.647	1.629	1.068
Secondary Shield Wall	78	0.350	0.391	0.395
	100a	0.459	0.474	0.508
	100b	0.520	0.533	0.403
	107	0.543	0.493	0.562
	114	0.613	0.501	0.616
	130	0.631	0.677	0.722
	137	0.690	0.772	0.748
	156	1.182	1.073	0.906
	191	2.524	4.846	1.217
Slabs	66	-	-	0.381
	100	-	-	0.800
	107	-	-	0.452
	111	-	-	0.858
	114	-	-	0.780
	125	-	-	0.768
	156	-	-	0.796

191a : Primary shield wall top

191b : Pressurizer room corners

100a : Secondary shield wall interface with concrete pedestal top

100b : In-containment refueling water storage tank walls

Response to Action Item 3-81 Section 3.7.2

SEB Issue List Regarding for APR1400 DCD Section 3.7.2 (Including Associated Technical Reports)

Issue #7 (AI 3-81.7)

Figure 1-3 in APR1400-E-S-NR-14006-P shows a cross section of the NI structures and common basemat. Among the details shown is the shear key configuration of the NI basemat. Based on Figure 6-3 in APR1400-E-S-NR-14002-P, related to the FEM (solid elements) for the side structural fill granular (SFG) backfill and lean concrete under the NI basemat (i.e. mudmat), the staff believes that the cavity directly under the RCB basemat is included in the dynamic model of the NI common basemat. However it is not clear if the basemat sections extending deeper than EL 45' (i.e. bottom of AB basemat) are included in the dynamic model. The applicant should clarify if the configuration of the basemat as shown on Figure 1-3 in APR1400-E-S-NR-14006-P is included in the dynamic model. If not, provide the technical basis for modeling assumptions.

Response

The response will be provided during the face to face meeting on October 5th & 6th.

Response to Action Item 3-81 Section 3.7.2

SEB Issue List Regarding for APR1400 DCD Section 3.7.2 (Including Associated Technical Reports)

Issue #8 (AI 3-81.8)

APR1400-E-S-NR-14002-P should clarify how the degree of freedom compatibility is addressed for transitions between beam and solid elements (e.g. RCS supported by the PWS and SSW).

Response

The compatibility condition between the beam elements of the reactor coolant system (RCS) and solid elements of the primary shield wall (PSW) and the secondary shield wall (SSW) was satisfied by using the rigid beam elements at the beam-to-wall support points covering the footprint of the RCS support brackets. RCS supports are modeled as rigid beam elements and connected with other rigid beam elements in the solid elements which represent the PSW and the SSW.

Figure 1 shows the connections between RCS supports (rigid beam) and building model (solid elements). A description of the beam-to-solid element connections will be incorporated in technical report APR1400-E-S-NR-14002-P.

Impact on DCD

There is no impact on the DCD

Impact on PRA

There is no impact on the PRA

Impact on Technical Specifications

There is no impact on the Technical Specifications

Impact on Technical/Topical/Environmental Reports

Technical Report, APR1400-E-S-NR-14002-P will be added as indicated in the attached markup.

Response to Action Item 3-81 Section 3.7.2

SEB Issue List Regarding for APR1400 DCD Section 3.7.2 (Including Associated Technical Reports)

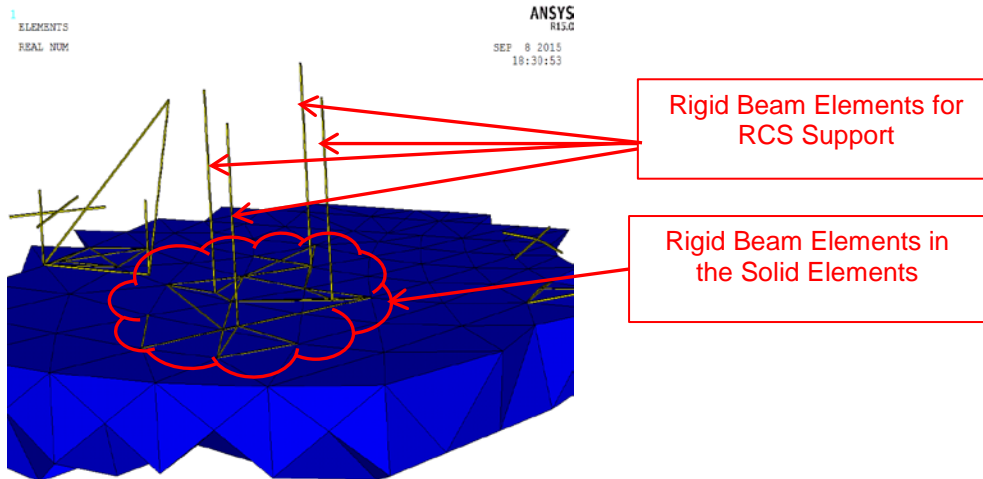

Figure 1. Connections between RCS Support and Solid Element

TABLE OF CONTENTS

1	INTRODUCTION	1
2	METHODOLOGY OF FEM DEVELOPMENT FOR NI STRUCTURES	2
3	REACTOR CONTAINMENT BUILDING MODEL	3
3.1	Description of RCB Structures.....	3
3.1.1	Containment Structure	3
3.1.2	Primary Shield Wall.....	4
3.1.3	Secondary Shield Wall	4
3.1.4	Reactor Coolant System	4
3.1.5	Internal Structure.....	5
3.2	Development of Finite Element Models for RCB Structures	5
3.2.1	Geometry and Coordinate System.....	5
3.2.2	Material Properties	6
3.2.3	Structural Member Modeling.....	6
3.2.4	Minimum Frequency of Seismic Wave Passage.....	6
3.2.5	Modeling of Mass (Structural Mass, Live Loads, Floor Loads and Equipment Loads).....	6
3.2.6	Modeling of Damping	7
3.2.7	Modeling of Hydrodynamic Effects for the IRWST.....	8
3.2.8	Modeling of Polar Crane	9
3.2.9	Modeling of CS.....	10
3.2.10	Modeling of PSW	10
3.2.11	Modeling of SSW	10
3.2.12	Mesh Sizes for Generation of ANSYS Fine and Coarse 3-D FEM of RCB	11
4	AUXILIARY BUILDING MODEL.....	12
4.1	Description of AB Structure.....	12
4.2	Development of Finite Element Models for AB Structure.....	12
4.2.1	Coordinate System.....	12
4.2.2	Material Properties	12
4.2.3	Common Basemat for AB and RCB.....	12
4.2.4	Shear Walls, Partial Wall Openings (Doors, Corridors, and Others), Equivalent Wall Thicknesses and Equivalent Mass Densities.....	13
4.2.5	Floor Slabs, Partial Floor Openings, Major Equipment, Earthquake Live Loads, Roof Snow Loads, Other Miscellaneous Dead Loads, and Equivalent Mass Densities	13
4.2.6	Modeling for Out-of-Plane Vertical Flexibility of Floor Slabs.....	13
4.2.7	Modeling for Columns and Girders	14

elements of the base. Mass duplication is avoided by assigning zero density to the penetrating shell elements.

3.2.13

~~3.2.12~~ Mesh Sizes for Generation of ANSYS Fine and Coarse 3-D FEM of RCB

The 3-D FE models have an adequate number of discrete mass degrees of freedom to capture the global and local translational, rocking, and torsional responses of the structures. The element size is selected so that the structural response is not significantly affected by further size refinement. In general, the fine model mesh size for the CS is 5 ft and for the IS approximately 6 ft. In contrast, the coarse mesh model element size is twice the fine mesh element sizes (i.e., 10 ft to 12 ft).

3.2.12 Modeling of RCS Support

The compatibility condition between the beam elements of the RCS and solid elements of the PSW and SSW is satisfied by using the rigid beam elements at the beam-to-wall support points covering the footprint of the RCS support brackets. RCS supports are modeled as rigid beam elements and connected with other rigid beam elements in the solid elements which represent the PSW and the SSW.

Response to Action Item 3-81 Section 3.7.2

SEB Issue List Regarding for APR1400 DCD Section 3.7.2 (Including Associated Technical Reports)

Issue #9 (AI 3-81.9)

The staff did not find a description in APR1400-E-S-NR-14002-P, Rev. 1 regarding damping values used in the HRHF analysis. Please include in APR1400-E-S-NR-14002-P, Rev. 1 a description of the damping values used in the HRHF evaluation.

Response

In the HRHF evaluation, the same structural damping values considered in CSDRS analysis are used. The description of the damping values used in the HRHF evaluation will be incorporated in technical report APR1400-E-S-NR-14002-P.

Impact on DCD

There is no impact on the DCD

Impact on PRA

There is no impact on the PRA

Impact on Technical Specifications

There is no impact on the Technical Specifications

Impact on Technical/Topical/Environmental Reports

Technical Report, APR1400-E-S-NR-14002-P will be added as indicated in the attached markup.

3 REACTOR CONTAINMENT BUILDING MODEL

This section describes the RCB structures and the methodology for developing the APR1400 RCB FEM.

3.1 Description of RCB Structures

The APR1400 RCB is a safety-related seismic category I structure that consists of three concrete substr

The RCB FE model including material properties and damping values are applied to both CSDRS and HRHF seismic analyses.

- Containment structure (CS)
- Primary shield wall (PSW)
- Secondary shield wall (SSW)

The CS is also called the pre-stressed concrete containment vessel. The PSW and the SSW are combined to form the reinforced concrete internal structure (IS) and are the supporting structures to the reactor coolant system (RCS).

The CS and IS are separated by a 2 in. gap and only connected at their basemat at El. 78'-0". Therefore, there is no interaction between the two structures except through the common basemat. The structural elements between the CS and IS are included in the SSW. The primary dimensions of the RCB are listed in Table 3-1.

3.1.1 Containment Structure

The CS consists of a cylindrical post-tensioned shell with 4.5 ft thick walls. The dome is hemispherical with 4 ft thick walls. The line at the intersection of the cylindrical and hemispherical shapes is called the spring line and lies at El. 254'-6".

The CS has four openings, as follows:

- Each opening has a diameter of 11.16 ft
- Two of the openings are on the north side, and others are on the east side.
- The personnel emergency exit airlock openings (one on the north side and another on the east side) are at center El. 103'-9" and azimuth 280°.
- The personnel access airlock openings (one on the north side and another on the east side) are at center El. 159'-9" and azimuth 234°.

The CS has one equipment hatch opening. The opening is on the east side, has a 26 ft circular opening, and is at center elevation at 167'-6" and azimuth 280°.

The CS has three 14 ft wide buttresses with thicknesses varying from 7.0 ft to 7.5 ft. The buttresses are 120° apart. The first buttress starts at azimuth 30° from the north. See Figure 3-1.

The CS cylindrical shell is supported on the RCB concrete foundation base at El. 78'-0". The interior of the CS shell structure is lined on with a 0.25 in steel liner plate, which acts compositely with the CS.

A polar crane is supported by the CS shell ring beam at El. 241'-0". The polar crane bridge girders and trolley system are supported by an inner steel ring beam with a 71.62 ft radius at approximately 5.6 ft offset from the CS shell center line using steel corbels (brackets).

4 AUXILIARY BUILDING MODEL

This section describes the AB structure and methodology of developing the APR1400 AB FEM.

4.1 Description of AB Structure

The APR1400 AB is a safety-related seismic category I structure with an embedment of approximately 54 ft (Ref. **The AB FE model including material properties and damping values are applied to both CSDRS and HRHF seismic analyses.**) basemat structures. Three adjacent structures, the emergency diesel generator building, turbine generator building, and compound building, are separated from the AB with a typical 3 ft building gap. This building layout with adjacent buildings is shown in Figure 4-1. The primary dimensions of the AB are listed in Table 4-1.

The AB houses important facilities including the fuel handling area, spent fuel pool, cask loading pit, refueling canal, cask decontamination pit, auxiliary feed water (AFW) tanks, main control room, equipment hatch access, and others. The AB structural system consists of shear walls in the east-west (E-W) and north-south (N-S) directions and a total of seven (7) major floor and roof slabs. The walls and slabs are made of normal reinforced concrete. Columns and girders are also used to support floor and roof slabs. The shear walls have various sizes of door openings and corridors partial openings on floor slabs.

4.2 Development of Finite Element Models for AB Structure

This section describes the development of 3-D AB FEM for SSI analysis.

4.2.1 Coordinate System

A rectangular Cartesian coordinate system is used for the ANSYS and SASSI models. The origin in a horizontal plan of this coordinate system is located at the center of the RCB. In this coordinate system, the positive X points to the plant east direction, the positive Y to the plant north direction, and the positive Z to the vertical upward direction, as shown in Figure 4-2.

4.2.2 Material Properties

The major AB structural components are reinforced concrete structures. Material properties of uncracked-concrete for the basemat, slabs, walls, and columns are listed in Table 4-2. Material properties for the horizontal cracked concrete model and vertical cracked concrete model based on the ASCE 43-05 are listed in Tables 4-3 and 4-4, respectively. Material properties of structural steel for columns and for girders are listed in Table 4-5. Critical damping ratios are taken from NRC RG 1.61.

4.2.3 Common Basemat for AB and RCB

The 10 ft thick basemat, as shown in Figure 4-3 serves as a common foundation for the AB and RCB. In the basemat, the central circular area with a radius of 83'-6" serves as the RCB foundation, while the rest of the basemat supports the AB with an embedment of 53'-6". The two buildings are separated with a minimum 2 in. seismic gap above the top surface of the common basemat at El. 55'-0".

The AB and RCB common basemat is modeled separately in the ANSYS by four (4)-node elastic SHELL63 elements for the AB at the bottom surface of the concrete foundation (El. 45'-0") to account more closely for SSI effects and by eight (8)-node SOLID45 elements for the RCB concrete foundation, as shown in Figure 4-4 for the coarse mesh. To provide continuation of rotational deformation at the interface of AB shell elements and RCB solid elements, a dummy massless ring of shell elements is extended from the edge to inside the RCB, beneath the solid elements as depicted in Figures 4-5 and 4-6.

Response to Action Item 3-81 Section 3.7.2

SEB Issue List Regarding for APR1400 DCD Section 3.7.2 (Including Associated Technical Reports)

Issue #10 (AI 3-81.10)

DCD Section 2.5.2.6 refers to the ISRS in 3.7A as the ones to be used for comparison with site specific seismic analyses. Please clarify the damping ratio for the ISRS that will be used for comparison by a COL applicant.

Response

The 5% damped ISRS will be used for comparison with the corresponding 5% damped ISRS obtained from the site specific seismic analyses. This description will be incorporated in DCD Tier 2, Table 1.8-2, Section 2.5.2.6 and Section 2.5.6.

Impact on DCD

DCD Tier 2, Table 1.8-2, Section 2.5.2.6 and Section 2.5.6 will be revised as indicated in the attached markup.

Impact on PRA

There is no impact on the PRA

Impact on Technical Specifications

There is no impact on the Technical Specifications

Impact on Technical/Topical/Environmental Reports

There is no impact on the Technical, Topical, or Environmental Report

APR1400 DCD TIER 2

Table 1.8-2 (2 of 29)

Item No.	Description
COL 2.5(1)	The COL applicant is to provide the site-specific information on geology, seismology, and geotechnical engineering as required in NRC RG 1.206.
COL 2.5(2)	The COL applicant is to confirm that the foundation input response spectra (FIRS) of the nuclear island are completely enveloped by the CSDRS-compatible free-field response motions at the bottom elevation of the nuclear island for a site with the low-strain shear wave velocity greater than 304.8 m/s (1,000 ft/s) at the finished grade in the free field. Alternately, the COL applicant is to confirm that FIRS of the nuclear island are completely enveloped by the CSDRS for a hard rock site with a low-strain shear wave velocity of supporting medium for the nuclear island greater than 2,804 m/s (9,200 ft/s).
COL 2.5(3)	The COL applicant is to confirm that the lower bound of the site-specific strain-compatible soil profile for a soil site is greater than the lower bound of the generic strain-compatible soil profiles used in the APR1400 seismic analyses.
COL 2.5(4)	The COL applicant is to confirm that the site-specific GMRS determined at the finished grade are completely enveloped by the hard rock high frequency (HRHF) response spectra for a site with a low-strain shear wave velocity of supporting medium for the nuclear island higher than 1,494 m/s (4,900 ft/s) overlaying a hard rock with a low-strain shear wave velocity of 1,494 m/s (9,200 ft/s). 5% damped
COL 2.5(5)	The COL applicant is to perform a site-specific seismic analysis to generate in-structure response spectra at key locations using the procedure described in Appendix 3.7A if COL 2.5(2) and COL 2.5(3) above are not met. In addition, the COL applicant is to confirm that the site-specific in-structure response spectra so generated are enveloped by the corresponding in-structure response spectra provided in Appendix 3.7A.
COL 2.5(6)	The COL applicant is to perform a site-specific seismic response analysis using the procedure described in Appendix 3.7B and the EPRI White Paper, "Seismic Screening of Components Subject to High Frequency Vibratory Motions," if COL 2.5(4) is not met. 5% damped
COL 2.5(7)	The COL applicant is to perform an evaluation of the subsurface conditions within the standard plant structure footprint based on the geologic investigation in accordance with NRC RG 1.132.
COL 2.5(8)	The COL applicant is to confirm that the dynamic properties of structural fill granular to be used in construction of the APR1400 seismic Category I structures satisfy the requirements of structural fill granular provided in Table 2.0-1.
COL 3.2(1)	The COL applicant is to identify the seismic classification of site-specific SSCs that should be designed to withstand the effects of the SSE.
COL 3.2(2)	The COL applicant is to identify the quality group classification of site-specific systems and components and their applicable codes and standards.
COL 3.3(1)	The COL applicant is to demonstrate that the site-specific design wind speed is bounded by the design wind speed of 64.8 m/s (145 mph).
COL 3.3(2)	The COL applicant is to demonstrate that the site-specific seismic Category II structures adjacent to the seismic Category I structures are designed to meet the provisions described in Subsection 3.3.1.2.
COL 3.3(3)	The COL applicant is to provide reasonable assurance that site-specific structures and components not designed for the extreme wind loads do not impact either the function or integrity of adjacent seismic Category I SSCs.

APR1400 DCD TIER 2

than 304.8 m/s (1,000 ft/s), the submaterials are completely excavated to expose competent material with a low-strain shear wave velocity equal to or greater than 304.8 m/s (1,000 ft/s), and the GMRS are defined as a free-field motion on the hypothetical outcrop after the excavation. For a site where the nuclear island is located on hard rock with a shear wave velocity greater than 2,804 m/s (9,200 ft/s), the site-specific GMRS can be defined at the foundation level. For this case, GMRS could be referred to as foundation input response spectra (FIRS) for the seismic Category I structures. The site-specific GMRS need to be transferred to the foundation elevations of each seismic Category I structure to obtain FIRS of each seismic Category I structure. The COL applicant is to confirm that the site meets the following requirements:

- a. For a site with a low-strain shear wave velocity greater than 304.8 m/s (1,000 ft/s) at the finished grade in the free field, the site-specific GMRS at the finished grade are completely enveloped by the APR1400 CSDRS shown in Figures 3.7-1 and 3.7-2. In addition, according to the NRC DC/COL-ISG-017 (Reference 5), the FIRS of the nuclear island are completely enveloped by the CSDRS-compatible free-field response motions at the bottom elevation of the nuclear island shown in Figures 3.7A-12 through 3.7A-14 (COL 2.5(2)).
- b. For hard rock sites with a low-strain shear wave velocity of supporting medium for the nuclear island greater than 2,804 m/sec (9,200 ft/s), FIRS of the nuclear island are completely enveloped by the CSDRS (COL 2.5(2)).
- c. For soil sites, the lower bound of the site-specific strain-compatible soil profile is greater than the lower bound of the generic strain-compatible soil profiles used in the APR1400 seismic analyses shown in Tables 3.7A-1 through 3.7A-9 and Figures 3.7A-3 through 3.7A-11 (COL 2.5(3)).
- d. For a site with a low-strain shear wave velocity of supporting medium for the nuclear island higher than 1,494 m/s (4,900 ft/s) overlaying a hard rock with a low-strain shear wave velocity greater than 2,804 m/s (9,200 ft/s), the site-specific GMRS determined at the finished grade are completely enveloped by the APR1400 HRHF response spectra shown in Figures 3.7-12 and 3.7-13 (COL 2.5(4)).
- e. If the requirements a, b, and c listed above are not satisfied, a site-specific seismic analysis is performed to generate in-structure response spectra at key locations using the procedure described in Appendix 3.7A. The site-specific in-structure

5% damped

APR1400 DCD TIER 2

5% damped

response spectra generated are compared with the corresponding in-structure response spectra provided in Appendix 3.7A (COL 2.5(5)). In addition, if the site-specific GMRS determined at the finished grade are not enveloped by the HRHF response spectra, site-specific seismic response analyses are performed using the procedure described in Appendix 3.7B and in the EPRI White Paper, “Seismic Screening of Components Sensitive to High Frequency Vibratory Motions” (Reference 6) (COL 2.5(6)).

2.5.2.7 Soil Uniformity

The APR1400 is designed for application at a site where the foundation conditions do not have extreme variation within the standard plant structure footprint. The subsurface may consist of layers that dip with respect to the horizontal. If the dip is less than 20 degrees, the generic analysis using horizontal layers is applicable as described in NUREG/CR-0693 (Reference 7). The physical properties of the foundation medium may or may not vary systematically across a horizontal plane. The methodology for checking uniformity is to calculate from the boring logs a series of “best-estimate” planes beneath the standard plant structure footprint that define the top and bottom of each soil or rock layer. These planes should represent and delineate stratigraphic boundaries, lithologic changes, and unconformities, but most important, they should represent boundaries between layers having different shear wave velocities. Shear wave velocity is the primary property used for defining uniformity of a site.

The distribution of bearing reactions under the basemat is a function of the subgrade modulus, which in turn is a function of the shear wave velocity and soil profile. Site-specific data should be provided to evaluate the variation of subgrade modulus or shear wave velocity across the footprint and to demonstrate the site is within the range considered for design of the standard plant structure basemat. The deeper that the non-uniform layer is located below the foundation, the less influence it has on the bearing pressures at the basemat.

The COL applicant is to perform an evaluation of the subsurface conditions within the standard plant structure footprint based on the geologic investigation in accordance with NRC RG 1.132 (COL 2.5(7)). Subsurface conditions may be considered uniform if the geologic and stratigraphic features can be correlated from one boring or sounding location to the next with relatively smooth variations in thicknesses or properties of the geologic units. An occasional anomaly or a limited number of unexpected lateral variations may

APR1400 DCD TIER 2

COL 2.5(5) The COL applicant is to perform a site-specific seismic analysis to generate in-structure response spectra at key locations using the procedure described in Appendix 3.7A if COL 2.5(2) and COL 2.5(3) above are not met. In addition, the COL applicant is to confirm that the site-specific in-structure response spectra so generated are enveloped by the corresponding in-structure response spectra provided in Appendix 3.7A.

5% damped

COL 2.5(6) The COL applicant is to perform a site-specific seismic response analysis using the procedure described in Appendix 3.7B and the EPRI White Paper “Seismic Screening of Components Sensitive to High Frequency Vibratory Motions” (Reference 6), if COL 2.5(4) is not met.

5% damped

COL 2.5(7) The COL applicant is to perform an evaluation of the subsurface conditions within the standard plant structure footprint based on the geologic investigation in accordance with NRC RG 1.132.

COL 2.5(8) The COL applicant is to confirm that the dynamic properties of SFG to be used in construction of the APR1400 seismic Category I structures satisfy the SFG requirements provided in Table 2.0-1.

2.5.7 References

1. Regulatory Guide 1.206, “Combined License Applications for Nuclear Power Plants,” U.S. Nuclear Regulatory Commission, June 2007.
2. Regulatory Guide 1.132, “Site Investigations for Foundations of Nuclear Power Plants,” Rev. 2, U.S. Nuclear Regulatory Commission, October 2003.
3. Regulatory Guide 1.138, “Laboratory Investigations of Soils and Rocks for Engineering Analysis and Design of Nuclear Power Plants,” Rev. 2, U.S. Nuclear Regulatory Commission, December 2003.
4. Regulatory Guide 1.208, “A Performance-Based Approach to Define the Site-Specific Earthquake Ground Motion,” U.S. Nuclear Regulatory Commission, March 2007.
5. NRC DC/COL-ISG-017, "Interim Staff Guidance on Ensuring Hazard-Consistent Seismic Input for Site Response and Soil Structure Interaction Analyses," U.S. Nuclear Regulatory Commission, August 2009.

Response to Action Item 3-81 Section 3.7.2

SEB Issue List Regarding for APR1400 DCD Section 3.7.2 (Including Associated Technical Reports)

Issue #11 (AI 3-81.11)

Some tables in Appendix B of APR1400-E-S-NR-14003-P (e.g. Table B-3, Table B-5, other) indicate that the weight of the CS between EL 125' and 130' is zero. The applicant should describe how the SSI models capture the inertial effects of the CS region between EI 125' and 130' given that the region is assigned a weight of zero.

Response

The response will be provided during the face to face meeting on October 5th & 6th.