

B&W'S POST TEST ANALYSIS
FOR SEMISCALE TEST S-07-10D

Document No. 86-1125888-00

May 20, 1981

Principal Investigators

T. E. Geer
P. A. Thornhill
R. C. Jones

Prepared by
Babcock & Wilcox Company
for

The Owners Group of Babcock & Wilcox
177 and 205 Fuel Assembly NSS Systems

8106090371

Introduction

The United States Nuclear Regulatory Commission (NRC) has sponsored research and development programs related to a postulated loss-of-coolant accident (LOCA) for light-water nuclear reactor systems. In order to evaluate the adequacy of the computer codes and models used in calculating transient behavior of the reactor coolant system during a small break LOCA, B&W was requested to provide a pretest prediction for the MOD-3 semiscale small break experiment (Test S-07-10B). The pretest prediction was completed in October of 1979 and submitted to the NRC via Reference 1.

Recently, the NRC requested that a post test evaluation of LOFT test L3-1 and semiscale test S-07-10D be performed. This report presents the post test analysis performed by B&W for the S-07-10D experiment. The L3-1 post test evaluation is presented in Reference 3. The objectives of the post test analyses were outlined in Reference 2 to be:

1. Evaluate the code predictive capability using initial and boundary conditions consistent with the actual test data.
2. Identify code modifications and/or improvements necessary to predict the test data.
3. Assess whether any improvements and/or modifications necessary for code predictions to agree with test data should be incorporated in present ECCS small break evaluation models.
4. Identify shortcomings in the test facility, instrumentation, etc., and their impact on code prediction capability, and recommend improvements to the test facility, instrumentation, or test procedures to improve the verification process.

A summary of this report is provided in Section 2. A description of the semiscale system along with the relationship between the S-07-10B and S-07-10D tests is provided in Section 3. Section 4 provides the analyses, results, and conclusions for the pretest and post test predictions.

2. Summary & Conclusions

This report presents B&W's post test evaluation of Semiscale Test S-07-10D. In the pretest evaluation of S-07-10B, it was noted that the system pressure did not decrease to the ECCS actuation pressure. As part of that submittal, several potential causes for the overprediction were identified. Comparisons of the pretest prediction to the actual S-07-10D test data generally confirmed that the causes identified in the pre test submittal were the sources for the discrepancy between the prediction and the test data. To perform the post test analysis, input changes were made to eliminate identified sources of the discrepancies. As shown in Section 4, substantial improvement was made in the prediction.

Relative to the specific concerns identified in Reference 2, the post test analysis confirmed that the CRAFT2 code can predict the small break LOCA phenomenon observed in the test, provided that adequate test conditions are provided. No code modifications were necessary for the post test evaluation. However, core nodding generally utilized for small break evaluations needed to be replaced by a more detailed and best estimate representation. This was necessary as the core nodding used in the evaluation model results in conservative results when core uncover occurs, as occurred in the S-07-10D test. In order to improve the verification process, it is suggested that a similar approach to that utilized for the recent L3-6 prediction be employed. That approach consisted of setting up a "blind pretest" model, release of the test data, and then a post test evaluation wherein changes from the "blind pretest" model must be justified.

3. S-07-10D Test

Semiscale test S-07-10D represented a 10 percent communicative cold leg break at pump discharge, from a system initially at 2283 psi and 606^oF (hot leg). The experimental configuration is shown in Figure 1. The primary coolant system has two loops; intact and broken. Each loop contains an operating steam generator and pump. A pressurizer is attached to the intact loop hot leg piping. The reactor simulator consists of an electrically heated core, upper head, upper plenum and lower plenum. Total core power was 1.927 MW and core flow rate was 21 lbm/sec. The broken loop steam generator steam valve was open throughout the S-07-10D transient.

The B&W pretest prediction was based on test S-07-10B; however, the initial conditions provided to B&W indicated that the broken loop steam generator secondary steam valve was open throughout the transient. Thus, the pretest model was set up with the valve open. During the review of the S-07-10B test data, EG&G concluded that the steam valve did not remain open, but rather the valve actually closed at 17 seconds into the transient. To compensate for this error and provide appropriate test data for comparison, test S-07-10D was performed using initial system conditions similar to S-07-10B and with the broken loop steam generator steam valve left open. Data for test S-07-10D was submitted to B&W by References 4 and 5. Since both B&W analyses, pretest and post test, were performed with the broken loop steam generator steam valve assumed open, the applicable test data for comparison purposes is that of the S-07-10D test.

4. Analysis

4.1 Pretest Prediction

The B&W pretest analysis results and conclusions were submitted to the NRC by Reference 1. While the calculated results were deemed to be reasonable

based upon the input assumptions utilized, it was recognized that the system pressure was overpredicted as the actuation setpoint for the ECCS was not reached. As part of the pretest submittal, potential causes for this overprediction were identified. These were:

1. Uncertainties in the blowdown of the broken loop generator.
2. Primary metal heat input appeared to be too large.
3. The single node model of the core with all core heat being deposited into that node results in excess steam generation when the core starts uncovering. (CORE2AL option)
4. The Bernoulli-Moody discharge model with C_d of 0.6 does not accurately predict leak flow when leak quality is high.

Experimental data for test S-07-10B was transmitted to B&W by Reference 6 on March 17, 1980. Comparison of the S-07-10E test data with the pretest prediction generally confirmed that the causes identified in the original pretest submittal were the causes for discrepancy between the analysis results and the test data. As a result of this review, it was decided to make the following major model changes for the post test evaluation:

1. Change the core model from a single node representation to several nodes to eliminate the conservatisms inherently associated with the CORE2AL option.
2. Force the broken loop steam generator secondary pressure to conform to the actual test pressure, since inadequate information is available to predict the secondary side response.
3. Utilize the HEM discharge model with $C_d = 1.0$ for two phase break flow.

The post test analysis, described in detail in the following section, demonstrates that these model changes substantially improve the predicted results.

4.2 Post Test Prediction

4.2.1 Post Test Analysis Model

The calculations performed and model developed for the pretest prediction were used extensively in the post test analysis. Modifications made to the

pretest model to obtain the post test model, along with a description of the approach taken, are presented in the following paragraphs.

As shown in Reference 5, the initial conditions for tests S-07-10B and S-07-10D were essentially the same; thus, the initial conditions used for the pretest prediction were deemed to be valid for the post test prediction. Table 1 contains both sets of initial conditions. The ECC parameters, however, had significant variation between the two tests and the correct values were input for the post test analysis. Table 1 also provides the ECC parameters used in the S-07-10D analysis.

The post test prediction was performed using version 17.0 of the CRAFT2 computer code (ref. 7), rather than version 8.4. Version 17.0 of CRAFT2 makes available the HEM model for break discharge. The computer deck was derived from the pretest prediction deck with changes made as required by format changes between version 8.4 and 17.0.

As noted in Section 4.1, there was uncertainty in the steam generator blowdown calculated in the pretest analysis. There were two factors which preclude an accurate prediction of steam generator secondary blowdown through the open steam valve:

1. Information on the secondary system piping geometry was not available.
2. Information on fluid quality leaving the secondary system was not available, due to uncertainty on the efficiency of the steam separator used in the test.

Lacking this information, it is very difficult to accurately predict steam flow characteristics.

To compensate for these unknowns, the pressure from the broken loop steam generator secondary was input as a boundary condition in the post test model. This was accomplished by utilizing the CRAFT relief valve actuation

pressure versus time table. Since both the intact loop and broken loop steam generators would be forced to follow the same pressure versus time table, heat transfer in the intact loop steam generator was stopped at 100 seconds by setting the heat transfer coefficient equal to zero. This action was judged to be acceptable because it had been determined (Reference 5 page 11) that the primary and secondary systems were somewhat decoupled during the majority of the transient due to high void fractions in the steam generator tubes and resultant poor heat transfer.

As was originally noted in the pretest submittal, primary metal heat input appeared to be too large in the pretest prediction. Since no primary metal temperature histories are available, a detailed evaluation of the primary metal heating concern could not be performed. However, at this time it is believed that the primary metal heats were reasonable.

In the pretest prediction for test S-07-10B, the CORE2AL option of the CRAFT computer code was utilized. With the option all core heat, regardless of flow direction, is deposited in a specified node. In the pretest prediction all core heat was deposited in the single core node. When the code predicts substantial core uncover, as occurred in the S-07-10B analysis, use of the CORE2AL option produces extremely conservative results relative to core uncover. This occurs because the core heat in the uncovered portion of the rods, is placed into the remaining liquid in the core. This leads to excessive boiling in the remaining liquid, and thus excessive pressurization. This assumption is conservative for small break LOCA predictions.

In the post test analysis, the CORE2AL option was eliminated. In order to allow for the heater rod axial power distribution, the core was modeled as several nodes. By doing this, only a small portion of the energy was added to the flow paths at the top and bottom of the core and most of the energy was added to the central portion of the core. By using a multinode representation,

the CRAFT calculated core heat transfer coefficients would now be based upon the inlet fluid condition to the core flow path. Thus, during a core uncover situation, a low surface heat transfer coefficient would be chosen for the core paths which have steam inlet conditions. In this manner, the actual heat transfer conditions in the core, i.e. good heat transfer in the covered portion of the rod vis-a-vis poor heat transfer in the uncovered portion of the rod, would be more closely approximated than by the CORE2AL, single node core representation.

In the pretest prediction the orifice equation and the Moody model, respectively, were utilized for subcooled and two-phase discharge models. Both models utilized a discharge coefficient of 0.6, which resulted in an underprediction of break flow for two-phase and steam discharge. For the post test analysis, the orifice equation with discharge coefficient equal to 0.6 was utilized for the subcooled condition, and the HEM model with discharge coefficient equal to 1.0 was used for two-phase fluid and steam conditions.

The resultant post test evaluation noding diagram is illustrated in Figure 2. In summary, the differences between the post test and pretest models are:

1. The ECC parameters for the post test evaluation were changed to represent the actual S-07-10D test condition.
2. The steam generator secondary pressure for the broken loop was used as a boundary condition for the post test evaluation. Due to code limitations, the intact loop steam generator secondary pressure had to be equivalent to that of the broken loop steam generator. To minimize the feedback of the intact loop steam generator pressure, the heat transfer coefficient was set to zero after 100 seconds.
3. A multinode core representation (6 nodes/7 paths) was chosen for the post test evaluation.
4. The saturated fluid discharge model was changed from the Moody correlation with a $C_D = 0.6$ to the HEM correlation with a $C_D = 1.0$.

4.2.2 Post Test Results

A sequence of events comparison between the experimental data and the post test analysis is provided on Table 2. For reference purposes, the pretest evaluation values are also shown. In general, a substantial improvement in results were obtained with the post test analysis, especially as related to core level response. Figures 3 through 7 present results of the evaluation. These are discussed more fully below.

Figure 3 presents a comparison of system pressure for both the pretest and post test results with the S-07-10D test pressure. The post test result is very close to the test data. Especially of interest is that the post test curve did not flatten out after 250 seconds like the pretest did. The HPIS came on at 467 seconds in the post test prediction as compared to 460 seconds in the test. The HPIS did not actuate in the pretest prediction. Examination of Figure 4 shows the reason for the differences.

Figure 4 presents a comparison of the integrated net energy removed from the primary system for the pretest and post test predictions. Energy into the primary system was from the core and primary metal, and energy out of the primary system was due to break flow and heat transfer to the steam generator secondaries. As is seen from the figure, after approximately 200 seconds there was little net energy removed from the system for the pretest prediction. However, the revised core and break flow models result in a continuous net energy removal and depressurization.

Figure 5 presents pressure versus time for the steam generator secondaries. As was previously noted, the secondary side pressure for both the intact and broken loop was forced to follow actual broken loop test pressure, during the post test prediction. Thus, the broken loop steam generator blowdown has been removed as a potential cause of errors in the post test analysis.

Figure 6 presents break mass flow rate versus time for the test, pretest prediction and post test prediction. It can be seen that the HEM discharge model with discharge coefficient of 1.0 (used in the post test prediction) provided results in closer agreement than the pretest prediction. However, the predicted mass flow rate was still somewhat below the actual test data. This is generally a result of the lower system pressure which was predicted as compared to the actual data (Figure 3).

Figure 7 is a presentation of core collapsed liquid level for the test, the post test prediction and the pretest prediction. As can be seen, the post test result compares favorably with the test data and is considerably different than the pretest prediction. This large change is attributed to a combination of the correction in the steam generator blowdown and the multinode core model. It is important to note that vessel refill, that occurred at ≈ 100 seconds due to the loop seal clearing, was calculated to occur in the post test prediction. Previously, none of the semiscale participants had predicted the vessel refill as was noted in Reference 5.

4.3 Conclusions

In general the post test prediction, through the time of HPIS actuation, was quite satisfactory and in good agreement with S-07-10D test data. Relative to the questions of Reference 2, the following specific conclusions can be made:

1. The post test evaluation, using initial and boundary conditions consistent with the actual S-07-10D test data, shows good agreement with test results.
2. No computer code modifications or improvements were found necessary to predict the test data. However, the CORE2AL option normally used in the small break LOCA evaluation model

needed to be replaced by a more detailed core representation to obtain best estimate calculations.

3. The CORE2AL option is conservative for the evaluation model; thus, the detailed changes made to obtain best estimate results need not be incorporated into the evaluation model.
4. Better specification of test parameters is necessary before calculations are performed. It is suggested that any future analysis be performed in the post test mode, similar to the L3-6 prediction.

5. References

1. Letter from J. H. Taylor (B&W) to Richard P. Denise (NRC), "Analysis Prediction for Test S-07-10B", dated October 9, 1979.
2. Letter to all B&W Licensees from Robert W. Reid (NRC), dated February 24, 1981.
3. N. K. Savani, R. C. Jones, " B&W's Post Test Evaluation of LOFT Test L3-1," Doc. No. 51-1125988-00, May 1981.
4. D. J. Shimeck, "Analysis of Semiscale MOD-3 Small Break Tests S-07-10 and S-07-10D", (EG&G Report EGG-SEMI-5201), July 1980.
5. Letter to J. H. Taylor (B&W Licensing) from J. A. Dearier (Code Assessment and Applications Branch) "Transmittal of Small Break Experiment Preliminary Comparison Report to Participants - JAD-4-81" dated January 8, 1981.
6. Letter from L. E. Phillips (Division of Systems Safety) to J. H. Taylor (B&W Licensing), "Experiment Data Release - Semiscale Test S-07-10B", dated March 17, 1980.
7. R. A. Hedrick, J. J. Cudlin and R. C. Foltz, CRAFT2 - Fortran Program for Digital Simulation of a Multinode Reactor Plant During Loss of Coolant, BAW-10092P, Revision 2, Babcock & Wilcox, April 1975.
8. J. R. Paljug, M. D. Gharakhani, R. C. Jones, B&W's Best Estimate Prediction of the LOFT L3-6 Nuclear Small Break Test Using the CRAFT2 Computer Code, Babcock & Wilcox, March 1981. Transmitted via letter from J. H. Taylor (B&W) to P. Check (NRC), March 20, 1981.

Table 1. Initial Conditions and ECC Requirements
for Semiscale Test S-07-10D

<u>Initial Conditions</u>	<u>Value Used from S-07-10B</u>	<u>Actual Data for S-07-10D</u>
Nominal System Pressure, psia	2250	2277
Hot Leg Fluid Temperature, °F	604.4	605
Cold Leg Fluid Temperature, °F	535.8	541
Core ΔT, °F	68.6	63
Core Inlet Flow, Lbm/sec.	21.4	21
Total Core Power, MW	1.927	1.94
 <u>ECC Parameters</u>		
Intact Loop Accumulator (Flood Tank)		
System Pressure at Actuation	232 psia	
Tank Pressure at Actuation	450 psia	
Liquid Volume	1.6 ft. ³	
Gas Volume	0.88 ft. ³	
Temperature	80 °F	
 <u>Intact Loop HPIS</u>		
Actuation Pressure	232 psia	
Injection Rate (Average)	0.17 Lbm/sec.	
Temperature	80 °F	
 <u>Intact Loop LPIS</u>		
Actuation Pressure	305 psia	
Injection Rate (Average)	0.24 Lbm/sec.	
Temperature	80 °F	

Table 2. Sequence of Events

<u>Event</u>	<u>Test S-07-10D Time (sec.)</u>	<u>Pretest Prediction Time (sec.)</u>	<u>Post Test Prediction Time (sec.)</u>
Blowdown initiated	0		0
Pressurizer pressure = 1800 psia	6.9	5.65	5.65
Begin core power decay	7.7		5-10
Pump coastdown initiated			
Upper plenum fluid saturates	8.0	6-10	5-10
Pressurizer empties	20	20	≈15
Entire system saturated	27	60	35-40
Upper plenum liquid level reaches hot leg	42		25
Pressure suppression system pressure reduction begins	52		60
Liquid from cold legs drains to vessel and pump suctions resulting in two-phase mixture at break	65-90	≈60	40-55
Power to pump terminated	69	69.6	69.6
Pumps stop	79		≈80
Top of support tubes uncovered in upper head	80		80
Pressure suppression system tank pressure reduction finished	160		250
Start dryout of core	268		260
Core completely voided	434	330	
Lowest point in post test (93%)			467
Accumulator injection begins	460		470
HPIS injection begins	460		467

MOD-3 SEMISCALE COLD LEG BREAK ASSEMBLY

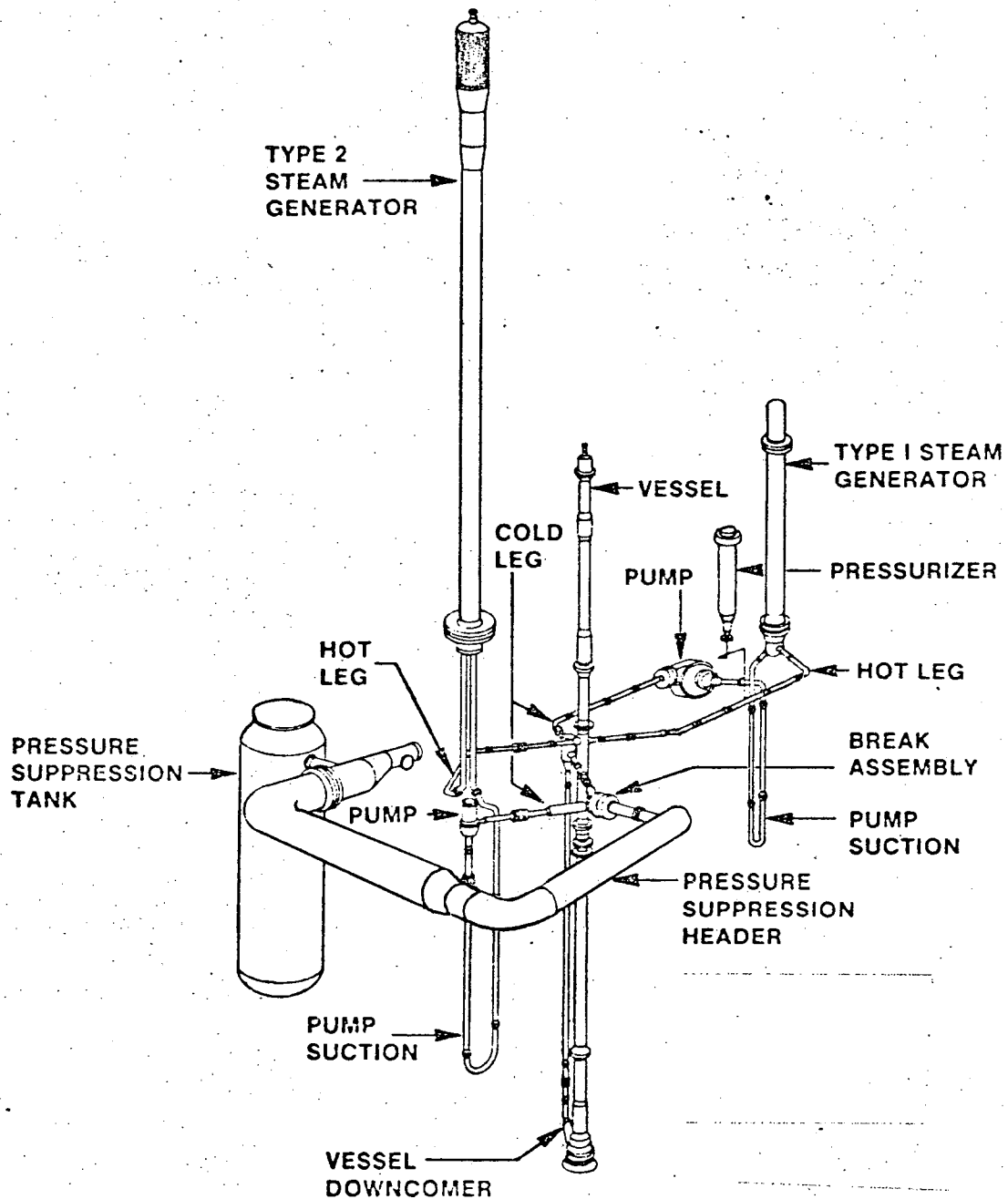

Figure 1. - Mod-3 Test System, Cold Leg Break Configuration

Figure 2 NODAL DIAGRAM FOR SEMISCALE S0710D POSTEST PREDICTIONS

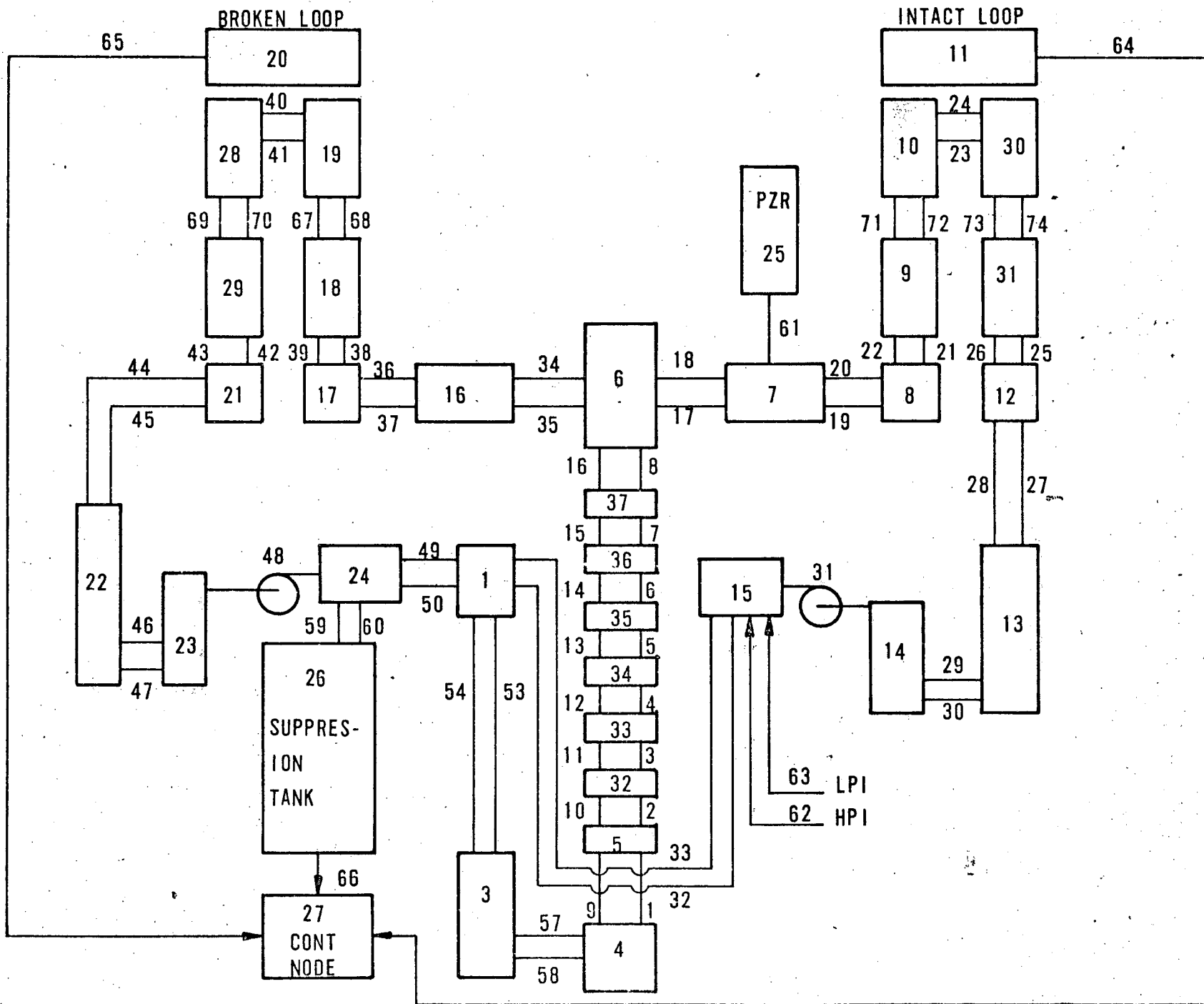

Figure 3 UPPER PLENUM PRESSURE

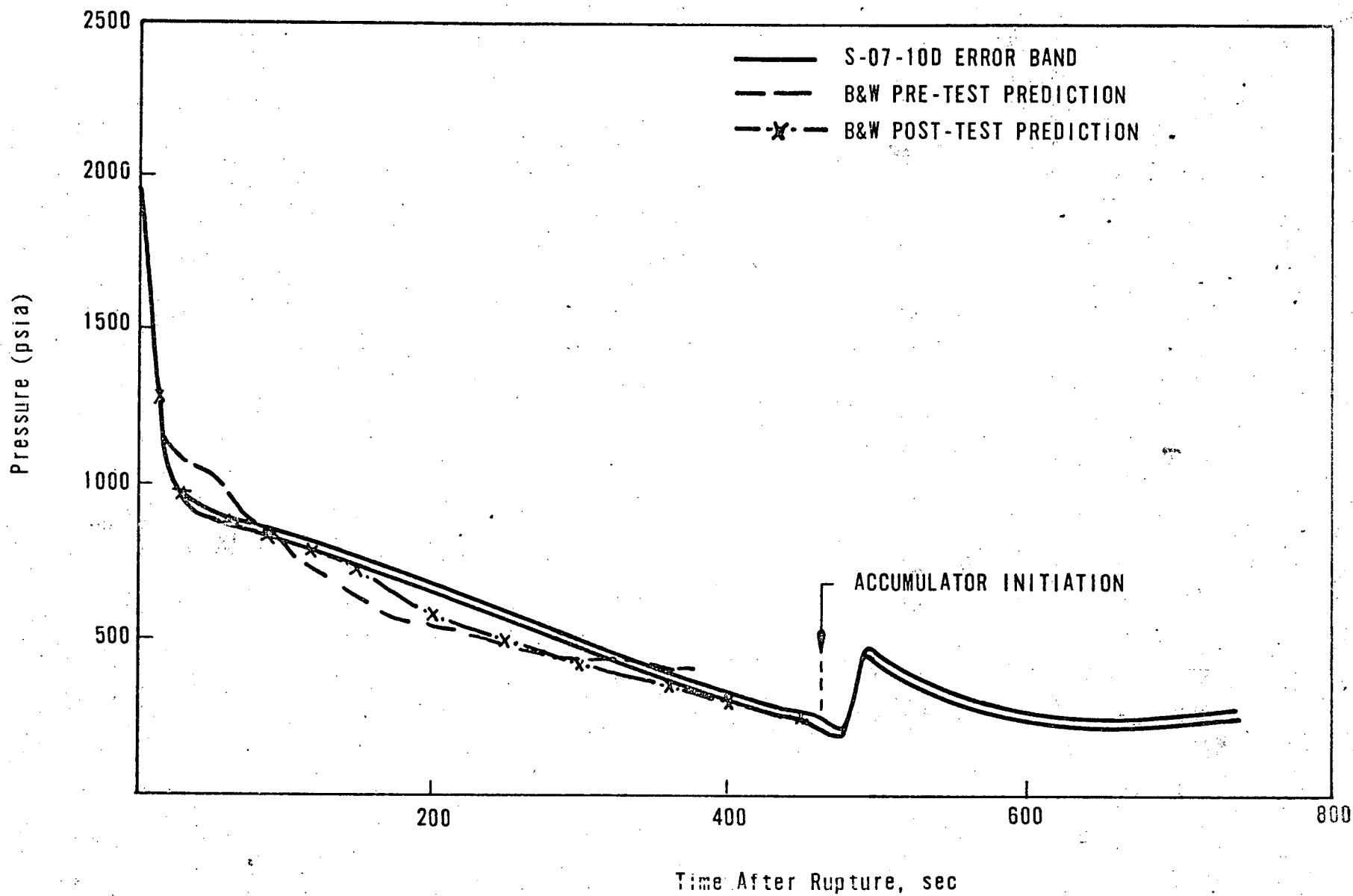

Figure 4 INTEGRATED NET ENERGY REMOVED FROM PRIMARY SYSTEM VS. TIME

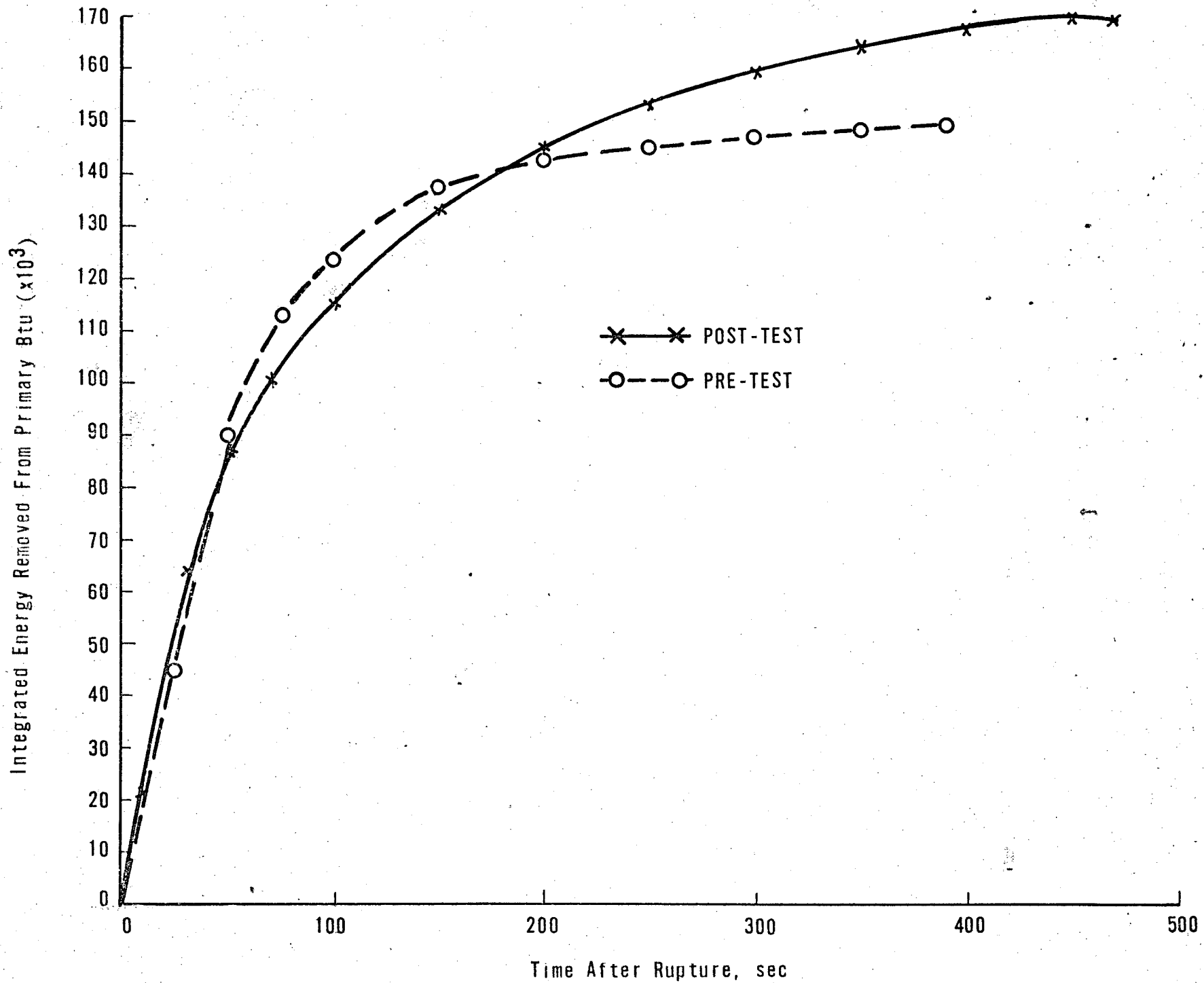

Figure 7 CORE COLLAPSED LIQUID LEVEL

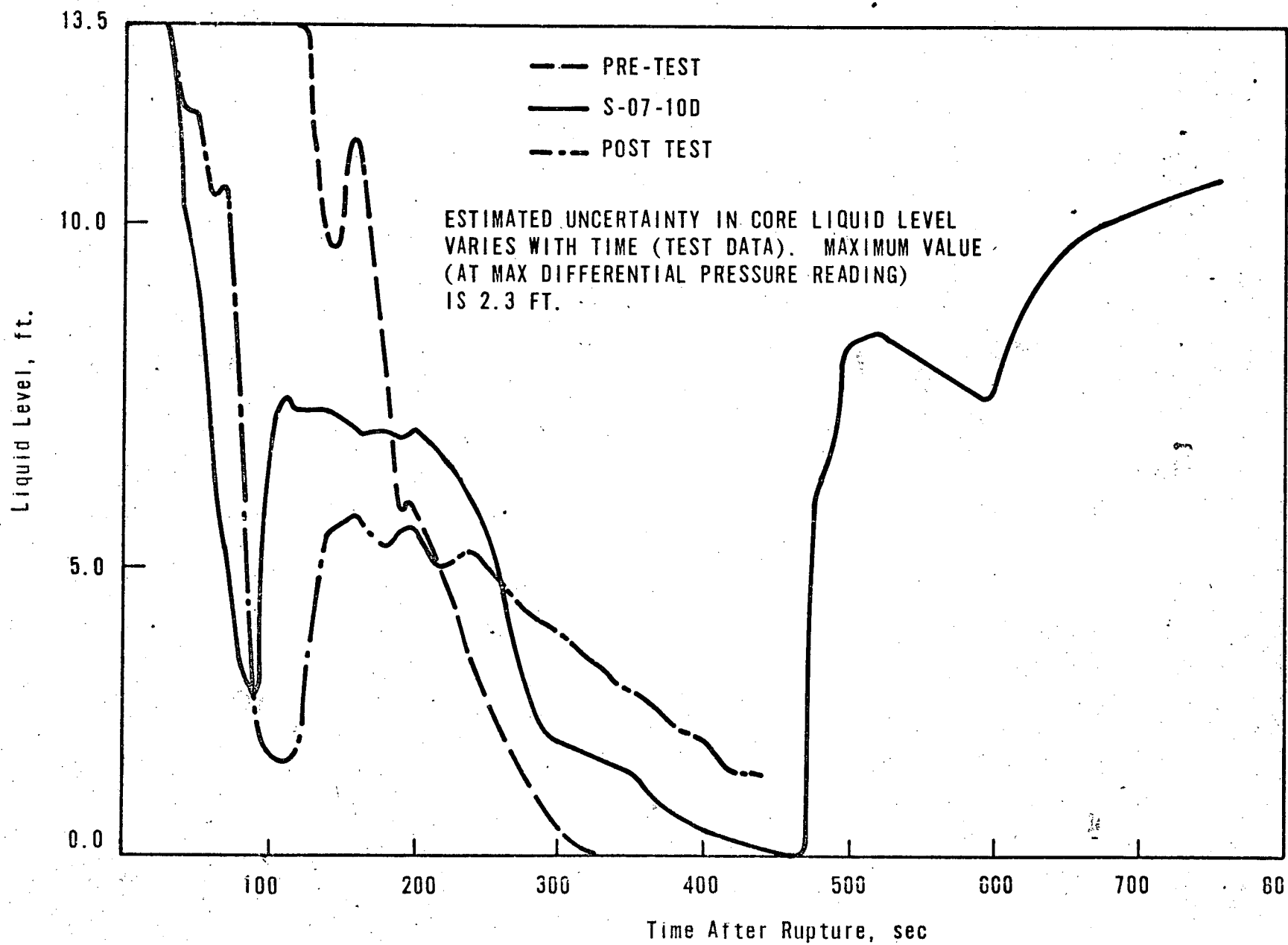

Figure 5 COMPARISONS OF MEASURED STEAM GENERATOR SECONDARY SIDE PRESSURE

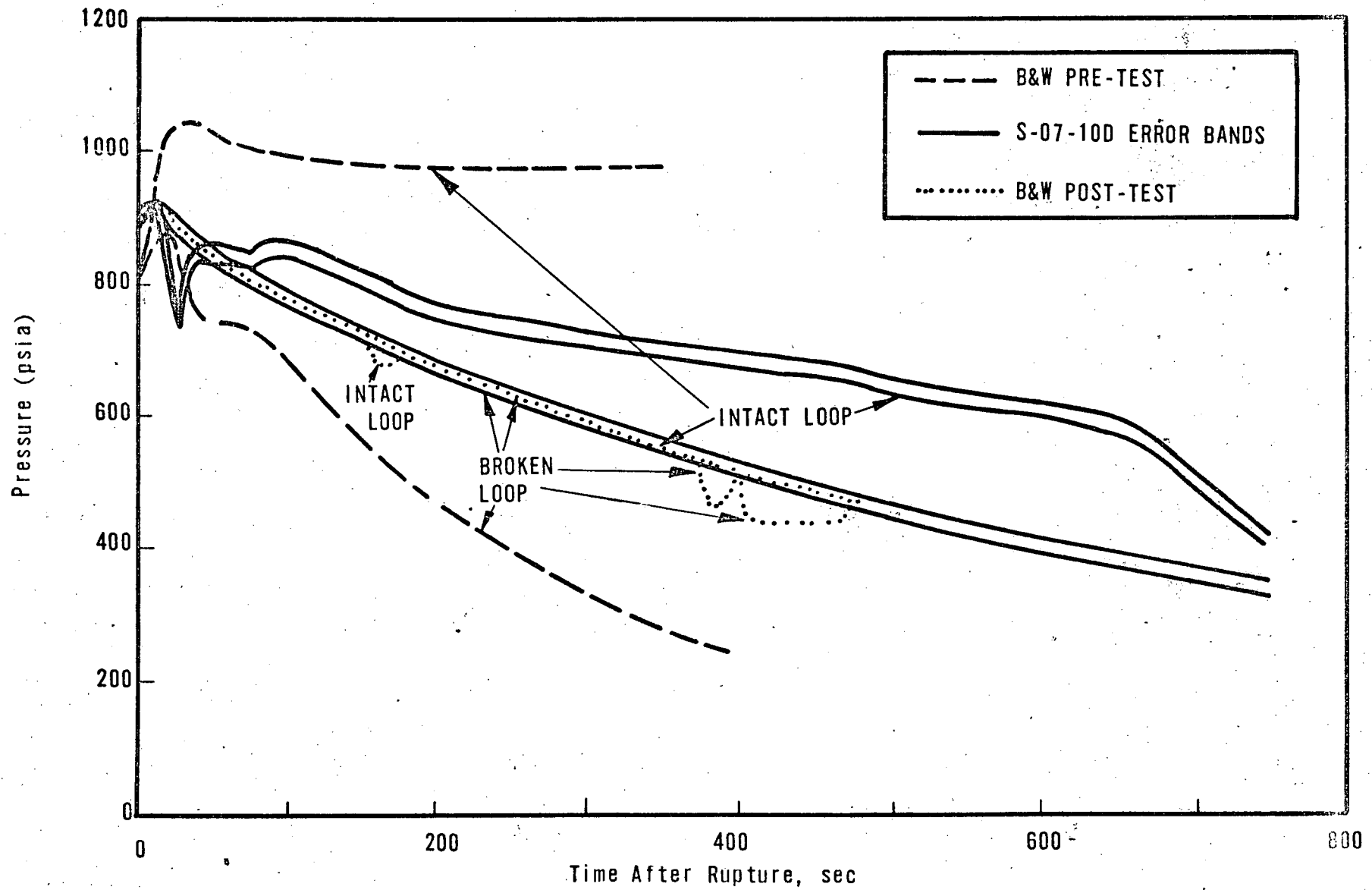

Figure 6 BREAK MASS FLOW RATE

