



AP1000 Passive Safety Systems

Stephen M. Bajorek, Ph. D.
Office of Nuclear Regulatory Research
United States Nuclear Regulatory Commission
Ph.: (301) 415-7574 / smb4@nrc.gov

AP1000 Design Workshop
August 2007



AP1000 Approach to Safety

● Passive Safety-Related Systems

- Use “passive” process only, no active pumps, diesels,
 - One time alignment of valves
 - No support systems required after actuation
 - No AC power, cooling water, HVAC, I&C necessary for mitigation
- Greatly reduced dependency on operator actions
- Mitigate design basis accidents without nonsafety systems

● Active Non-safety Related Systems

- Reliably support normal operation
 - Redundant equipment powered by onsite diesels
- Minimize challenges to passive safety systems
- Not required to mitigate design basis accidents



Passive Safety Features

- **Passive Decay Heat Removal**

- Natural circulation HX connected to RCS

- **Passive Safety Injection**

- Natural circulation / gravity drain core makeup tanks (RCS pres)
- N₂ pressurized accumulators; Initial pressure = 700 psig (4.9 MPa)
- Gravity drain refueling water storage tank (containment pres)
- Automatic depressurization valves, Pzr & HL

- **Passive Containment Cooling**

- Natural circulation of air / evaporation of water on outside surface of steel containment vessel

- **Passive Radiation Removal from Containment Atm.**

- Natural circulation / removal mechanisms



Passive Safety Features

- **Passive Main Control Room (MCR) Habitability**
 - Compressed air pressurization of MCR
- **Passive MCR / I&C Room Cooling**
 - Natural circulation to concrete walls / ceiling
- **Passive Containment Hydrogen Control**
 - Autocatalytic recombiners
- **Passive Containment pH Control**
 - Baskets of TriSodium Phosphate flooded by accident



AP1000 Passive Core Cooling System

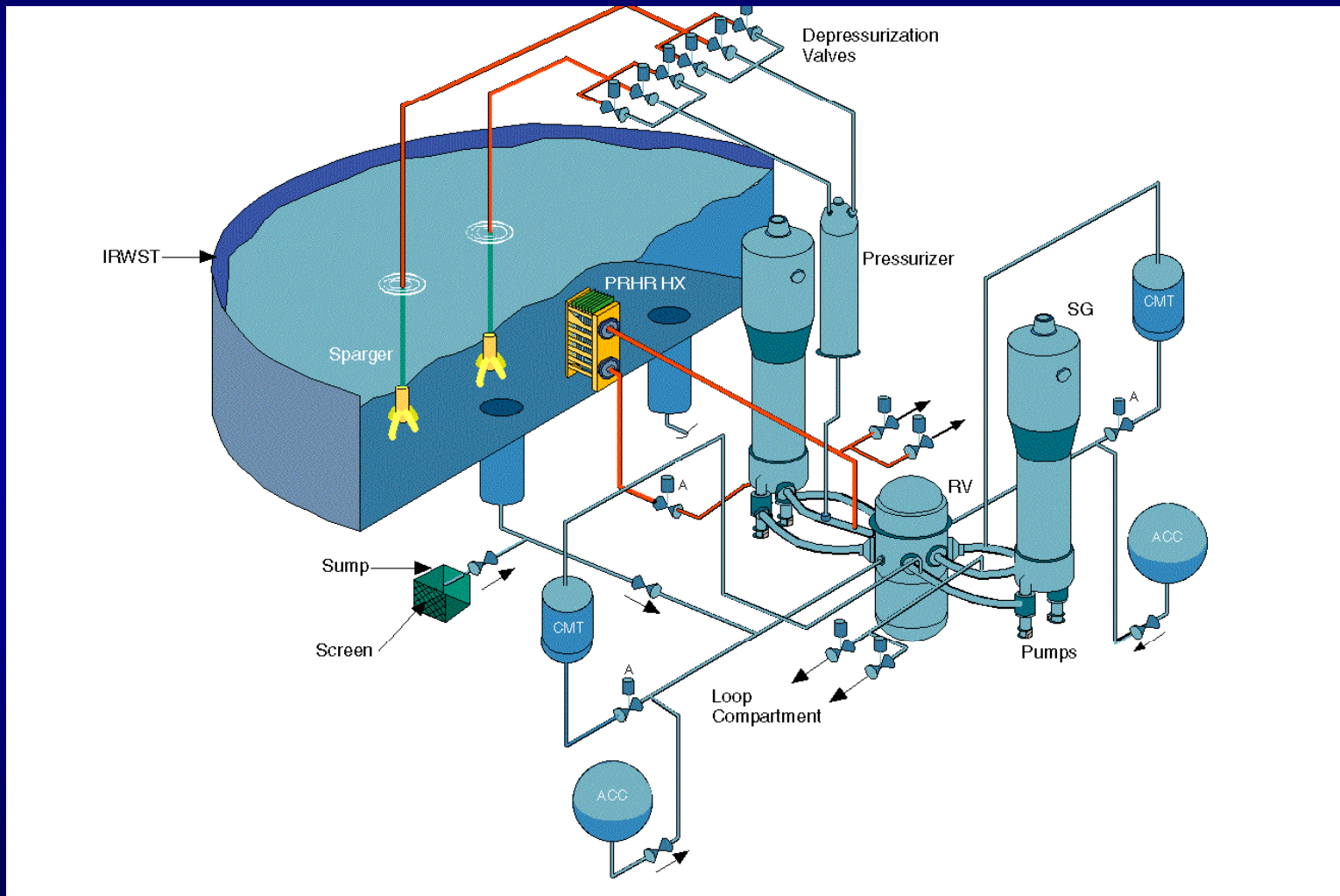



AP1000 Passive Core Cooling System

- **PRHR Heat Exchanger**

- Natural circulation heat removal

- **Passive Safety Injection**

- Core Makeup Tanks (CMT)
 - Full RCS pressure, natural circ. injection
 - Replace HSI pumps
- Accumulators
 - Similar to current plants
- IRWST Injection
 - Low pressure (replaces LHSI pumps)
- Containment Recirculation
 - Gravity recirculation replaces pumped recirc)
- Automatic RCS Depressurization
 - Staged, controlled depressurization
 - Stages 1-3 to IRWST, stage 4 directly to containment

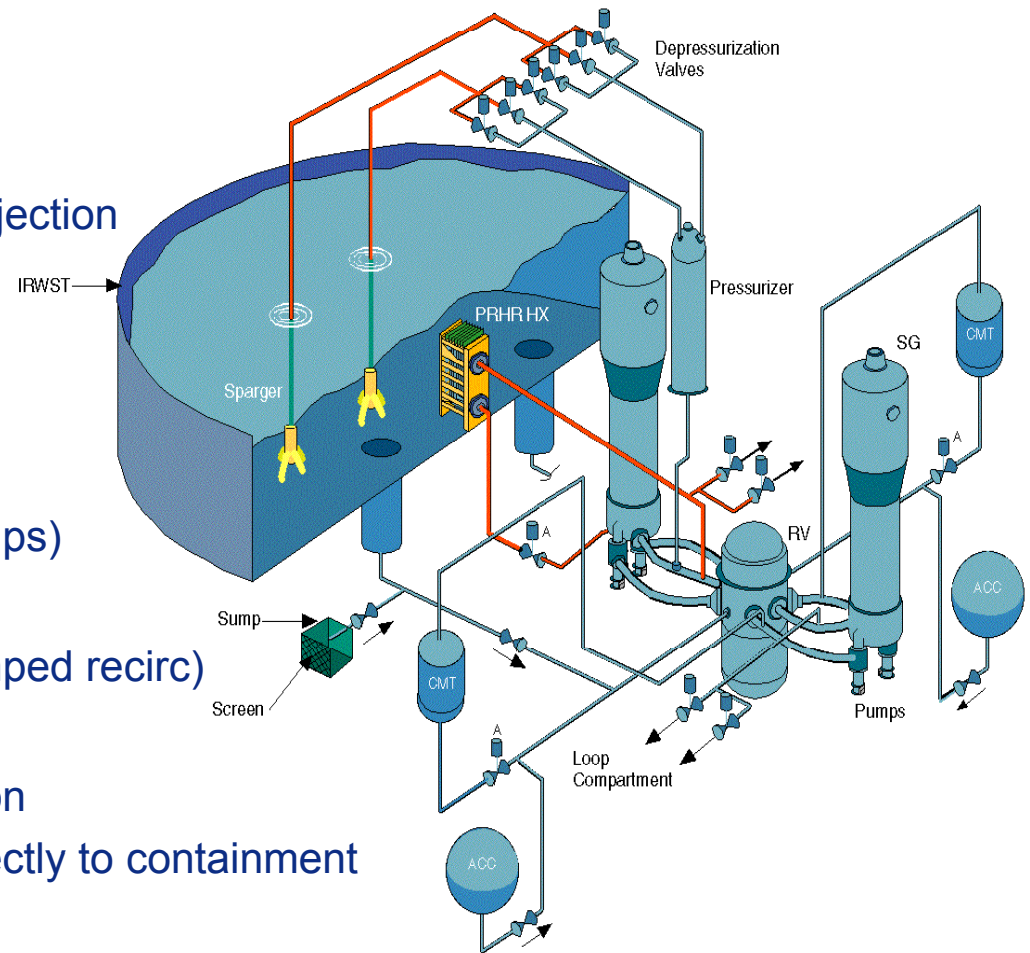



AP1000 Passive Core Cooling System

- **Based on AP600 Systems**
 - Extensive testing and analysis
 - Reviewed by US NRC
 - No active pumps, DGs, chillers
 - One time valve alignment
 - Most are fail safe
- **AP1000 Capacities Increased to Accommodate Higher Power**
 - System Performance Maintained
 - Transient DNBR margin > 15%
 - No core uncover for SBLOCA
 - \leq DVI line break
 - Large margin to PCT limit
 - No operator actions for SGTR

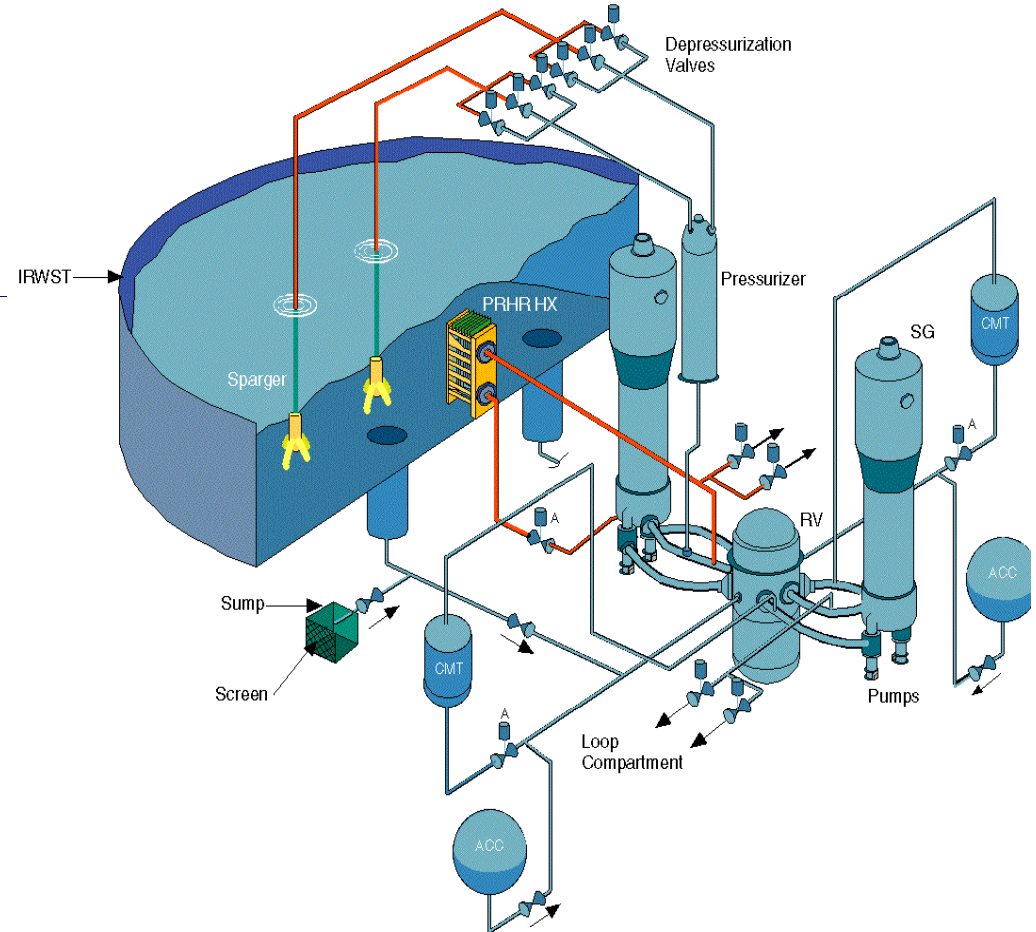



AP1000 Passive Core Cooling System

- **AP600 System Configuration Retained**
- **Capacities Increased to Accommodate Higher Power**

- Core 1933 MW > 3400 MW or 76%
- PRHR HX Capacity Increased 72%
- CMT Volume & Flow Increased 25%
- ADS-4 Flow Increased 93%
- IRWST Injection Increased 89%
- Containment Recirc. Increased 139%

- **System Performance Maintained**

- No core uncover for SBLOCA
 - \leq DVI line break
 - Large margin to PCT limit
- No operator actions required for SGTR

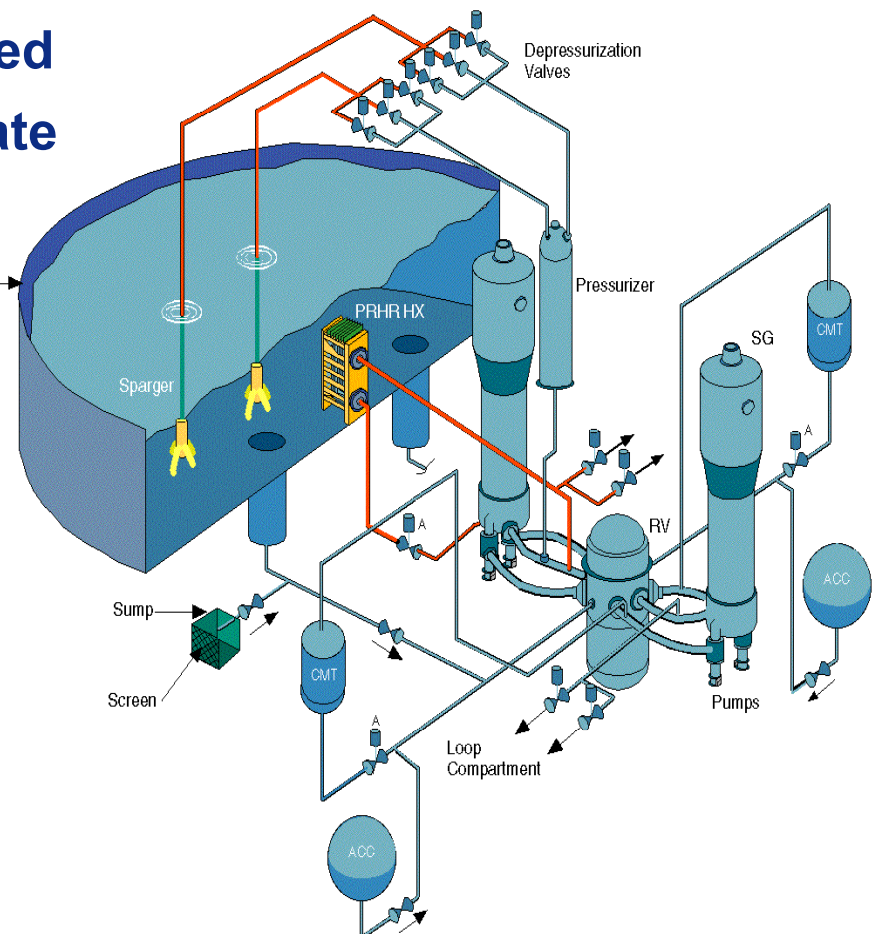



Passive Decay Heat Removal

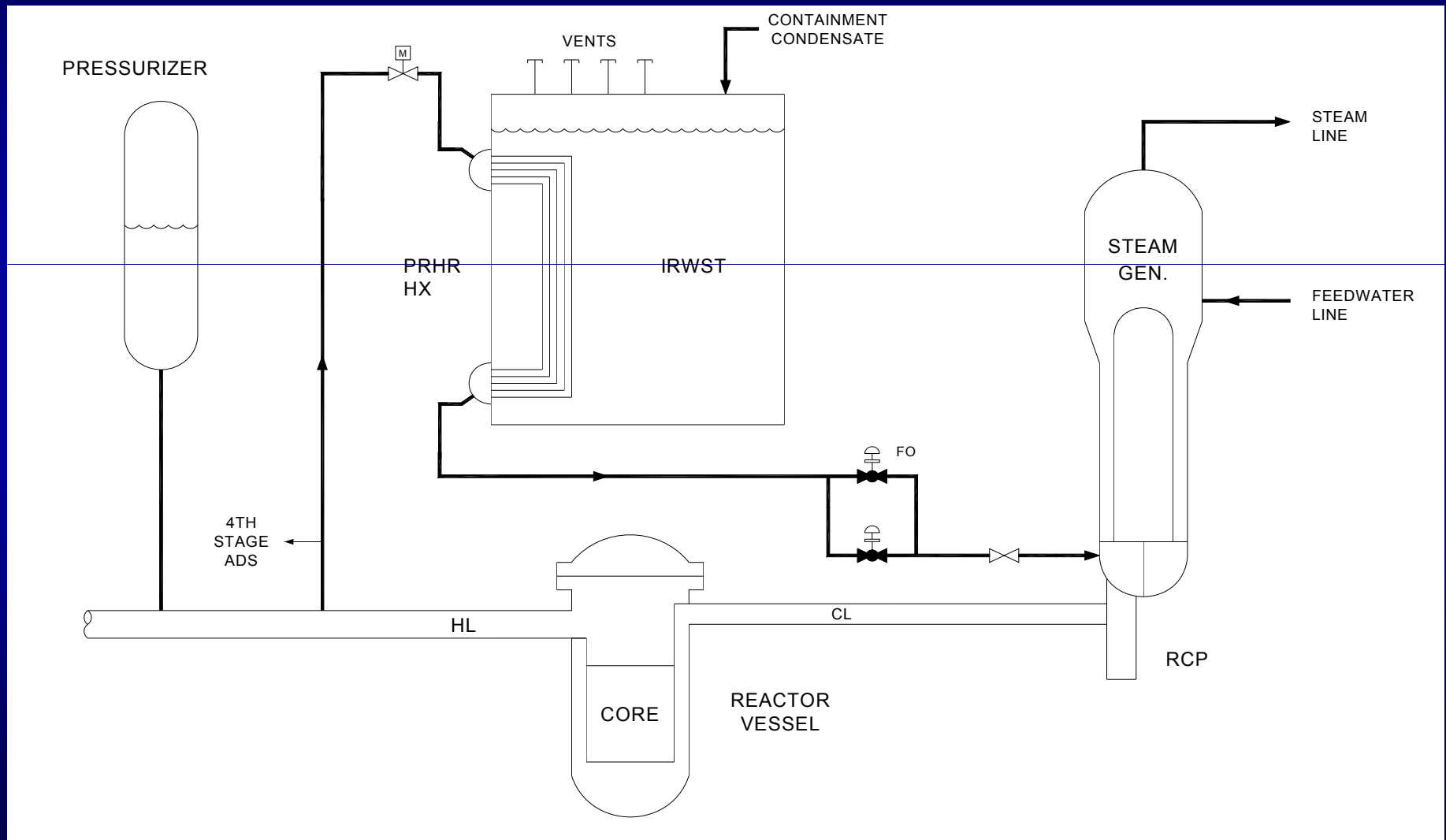



Passive Decay Heat Removal

- **The passive residual heat removal (PRHR) system is designed for 100% decay heat removal.**
- **Protects plant from upsets in normal steam generator feedwater and steam system.**
- **IRWST provides heat sink for PRHR HX**
- **PRHR HX with passive containment cooling system provides infinite decay heat removal capability without operator action.**



AP1000 PRHR HX

- **Size Based on AP600 Tests**
 - Full size tubes
 - Full pressure / temperature
- **Connected to IRWST Wall**
 - “C” tubes provide flexibility
 - No pipes in IRWST
 - No pipe break induced dynamic effects
 - Access from outside IRWST
 - Easy tube inspection
- **Uses Proven SG Technology**
 - Flat tube sheet
 - Tube / tube sheet connection
 - 3/4” Inconel 690 TT tubes
 - SG tube inspection methods

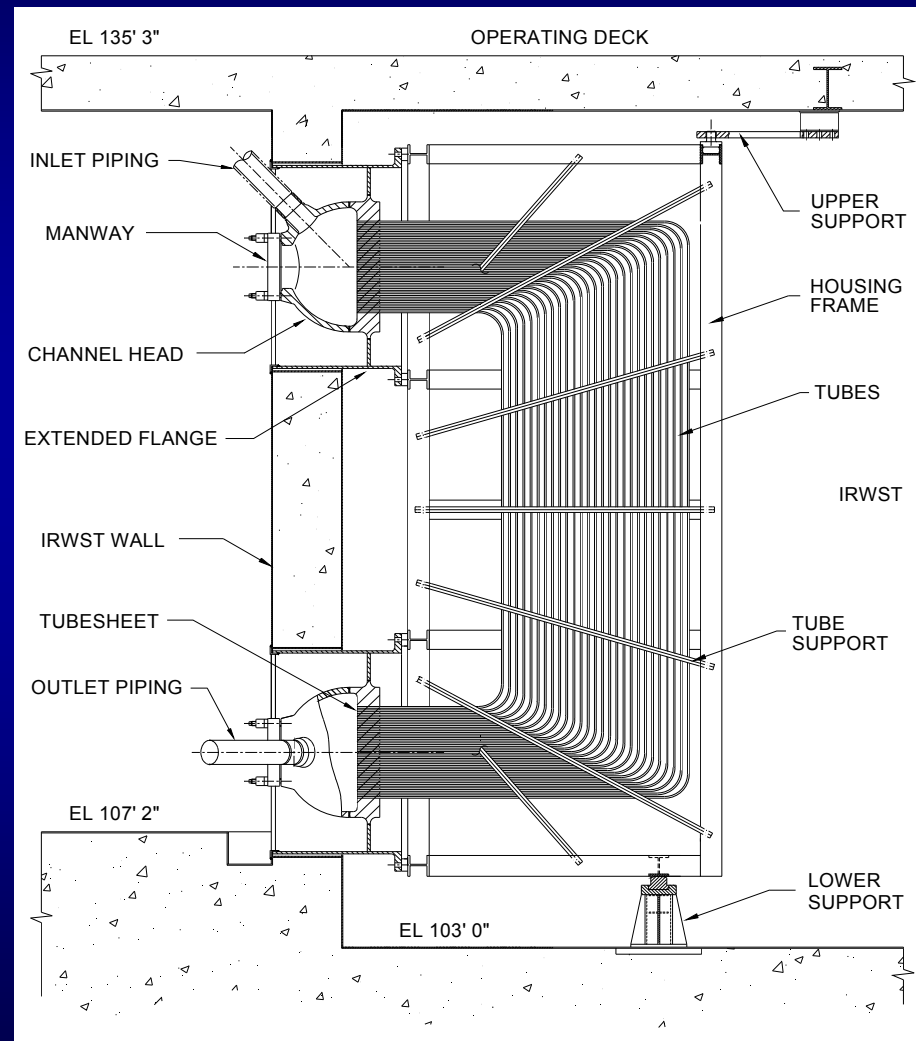



Passive RHR Heat Exchanger

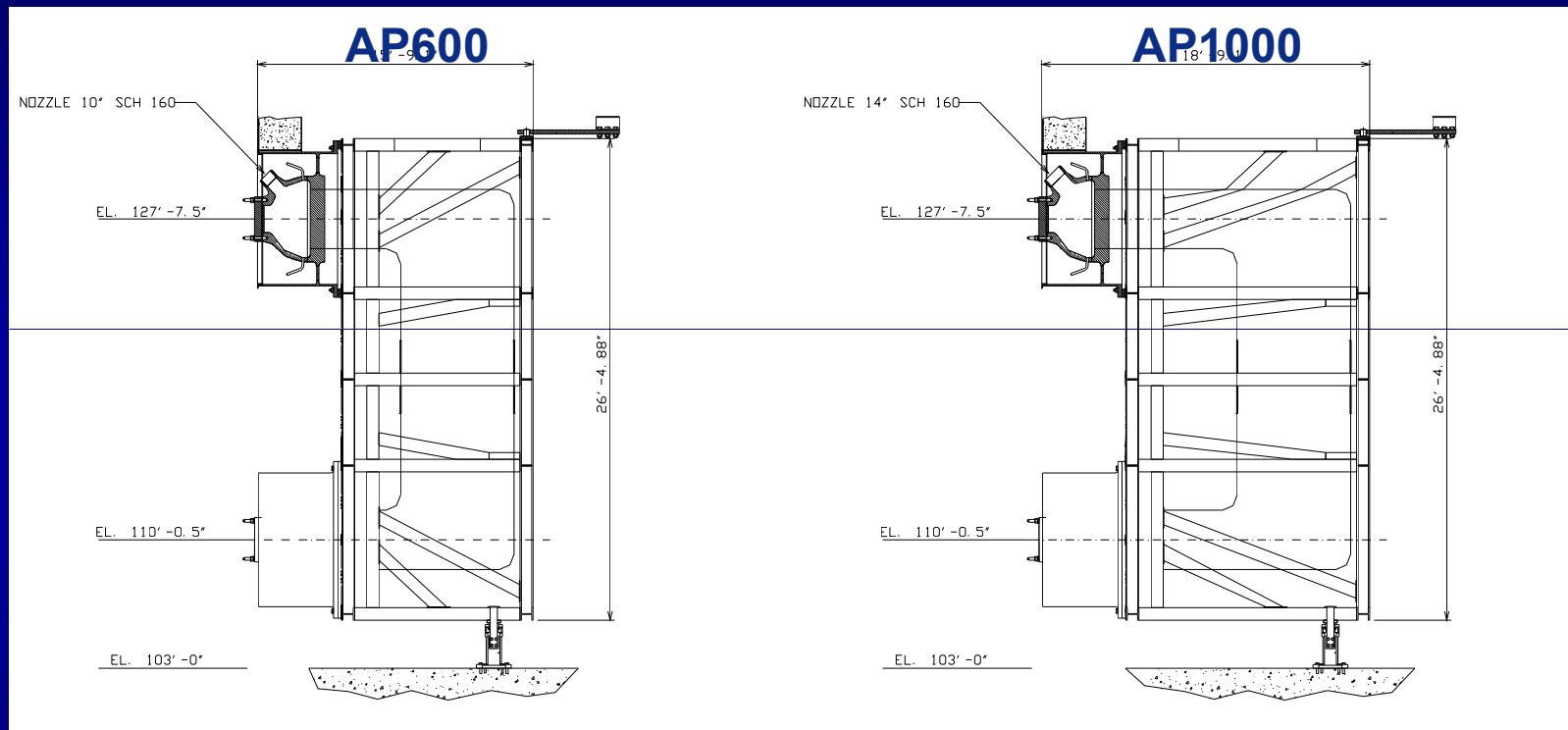

- **AP1000 PRHR Heat Transfer Capacity Increased 72% Above AP600**
 - Pipe / valves increased to 14" (AP600 10")
 - 9 more tubes, 3 ft. (1 m) longer horizontal tube length
- **Safe Shutdown Capability Maintained ; 420 F (488 K) in 36 hours**



PRHR Equipment Layout

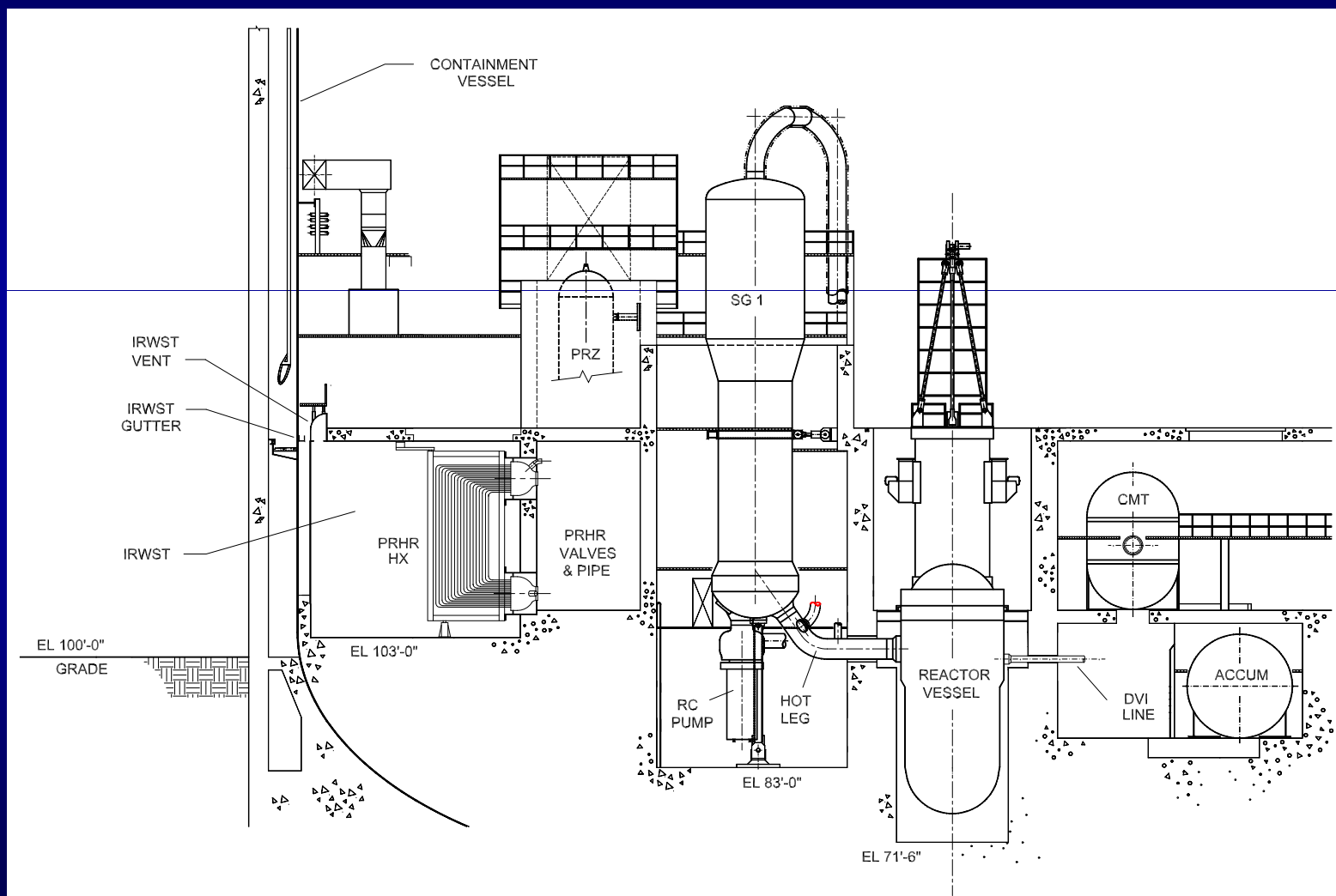



AP1000 Passive Safety Injection

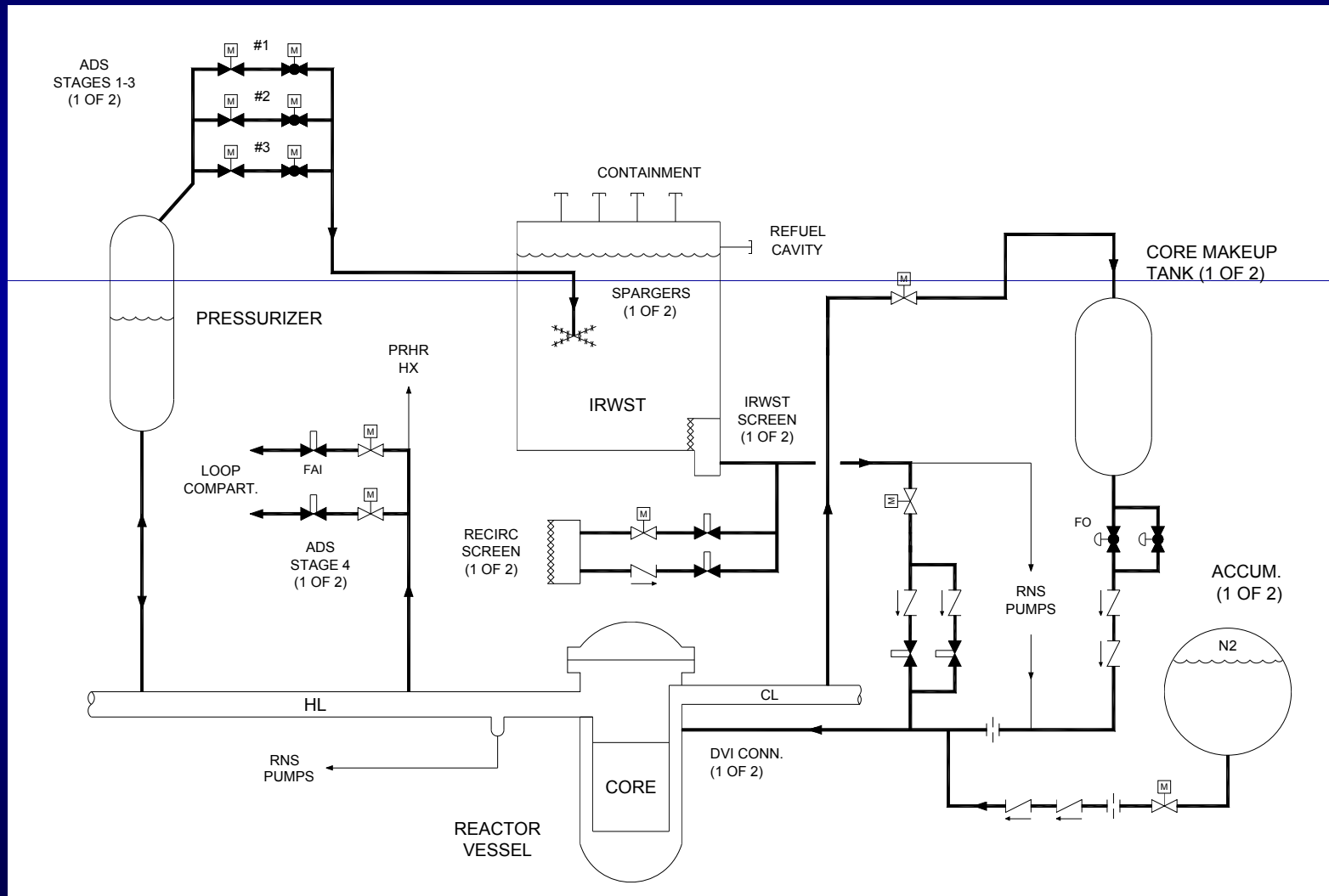



AP1000 Passive Safety Injection

- **The AP1000 passive safety injection system uses three sources of water for RCS make-up.**
- **CMTs (Core Make-up Tanks) provide coolant at full system pressure to downcomer through DVI (direct vessel injection) line.**
- **Two accumulators provide coolant at high flow rates once RCS pressure is < 700 psig (4.9 MPa).**
- **IRWST supplies borated water to RCS once the primary system has depressurized to low pressure.**



AP1000 Core Makeup Tanks

- **Core Makeup Tanks (CMTs) provide coolant at full RCS pressure and eliminate the need for HPSI pumps.**
- **AP1000 CMTs have capacity to mitigate most small LOCAs.**
 - Maintains time available for ADS to depressurize RCS to IRWST cut-in
 - No core uncover for design basis small LOCAs up to DVI line break.
 - Required to meet PRA success criteria (for multiple failure scenarios w/o accumulators).

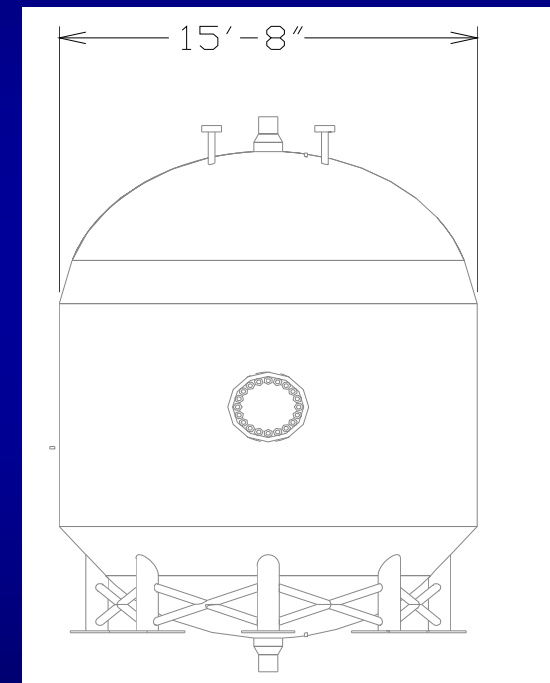



AP1000 Core Makeup Tanks

- **CMTs Operate in Two Modes:**
 - **Hot water recirc mode**
 - When Cold Leg (CL) is filled
 - For non-LOCAs and initial small LOCAs
 - Initial flow is ~ 29 lbm/s (13.2 kg/s) each to RCS
 - Duration is ~ 100 min.
 - **Steam displacement drain mode**
 - When CL voids during LOCA
 - Initial flow is ~ 135 lbm/s (61.2 kg/s) each
 - Final flow is ~ 71 lbm/s (32.2 kg/s) each
 - Duration is ~ 25 minutes
 - **Sized for DVI LOCA**
 - Remove decay heat after accumulators empty
 - **Controls ADS actuation**
 - Low1 starts ADS 1 (67% vol)
 - Low2 starts ADS 4 (20% vol)

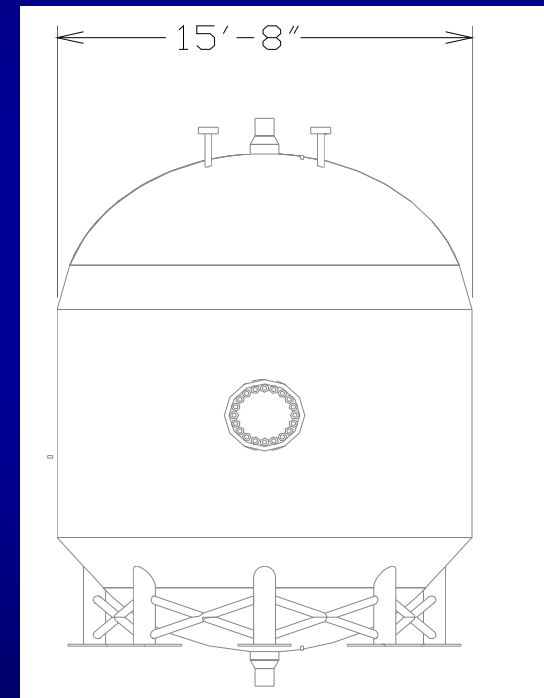



AP1000 Core Makeup Tanks

AP600

AP1000

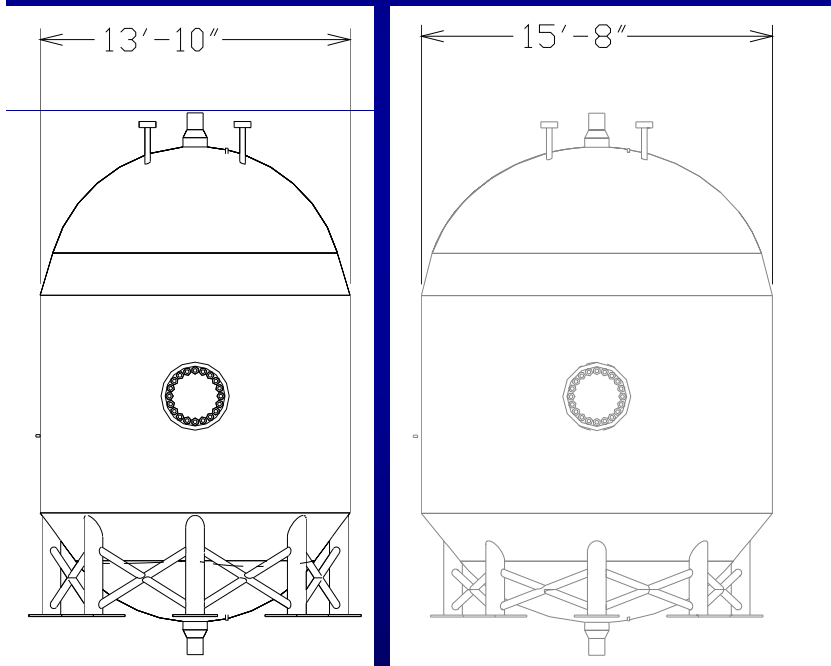

- Compared to AP600, the AP1000 CMT volume and flow capacity was increased by 25%.
 - AP1000 volume is 2500 ft³ (70.8 m³)
 - AP600 volume is 2000 ft³ (56.6 m³)
 - Re-tuned flow control orifice with same pipe size
 - Maintains duration of CMT injection same as AP600
 - Maintains time available for ADS to depressurize RCS to IRWST cut-in



AP1000 Accumulator

- Accumulators are spherical tanks containing borated water and pressurized to approximately 700 psig (4.9 MPa) with nitrogen cover gas.
- Are designed to provide high rate of coolant flow for several minutes to mitigate large LOCAs.



AP1000 Accumulator

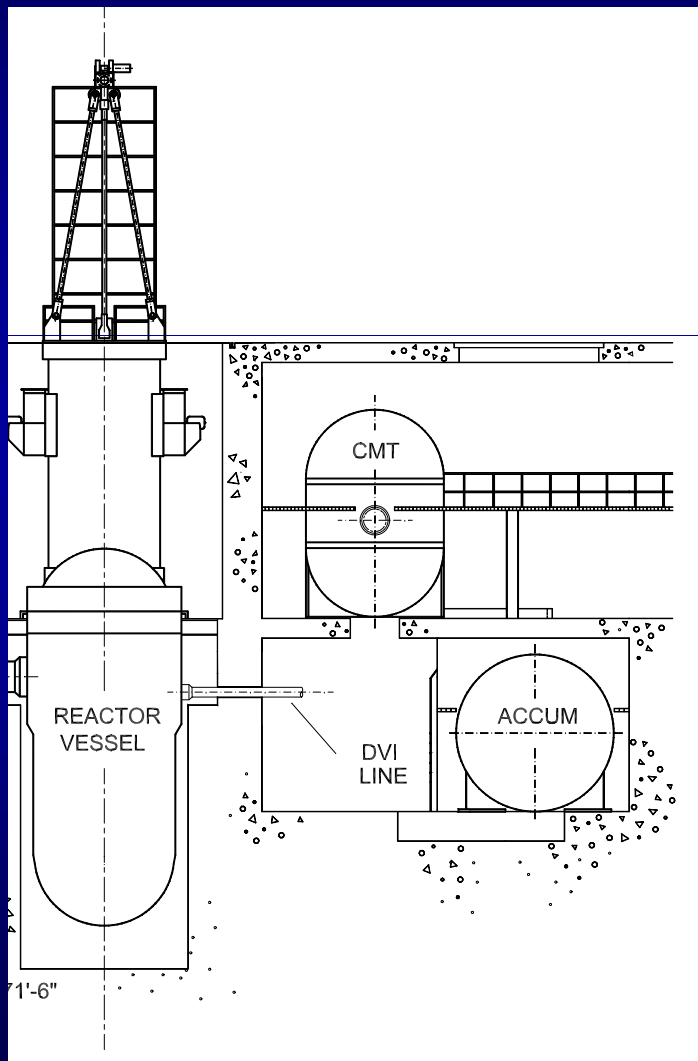

- **Compared to AP600, Accumulator Volume / Flow Not Changed**
 - Controlling accident is LBLOCA.
 - Increasing Accum volume is difficult
 - Would impact containment layout
- **AP1000 Large Break LOCA**
 - Margin to 2200 F (1478 K) fuel acceptance limit remains for DBA LBLOCA.
 - For PRA, change success criteria
 - Require 2 of 2 accum (same as DBA) for large RCS pipe breaks
 - Require 1 of 2 accum for spurious ADS stage 4 events



AP1000 Accumulator

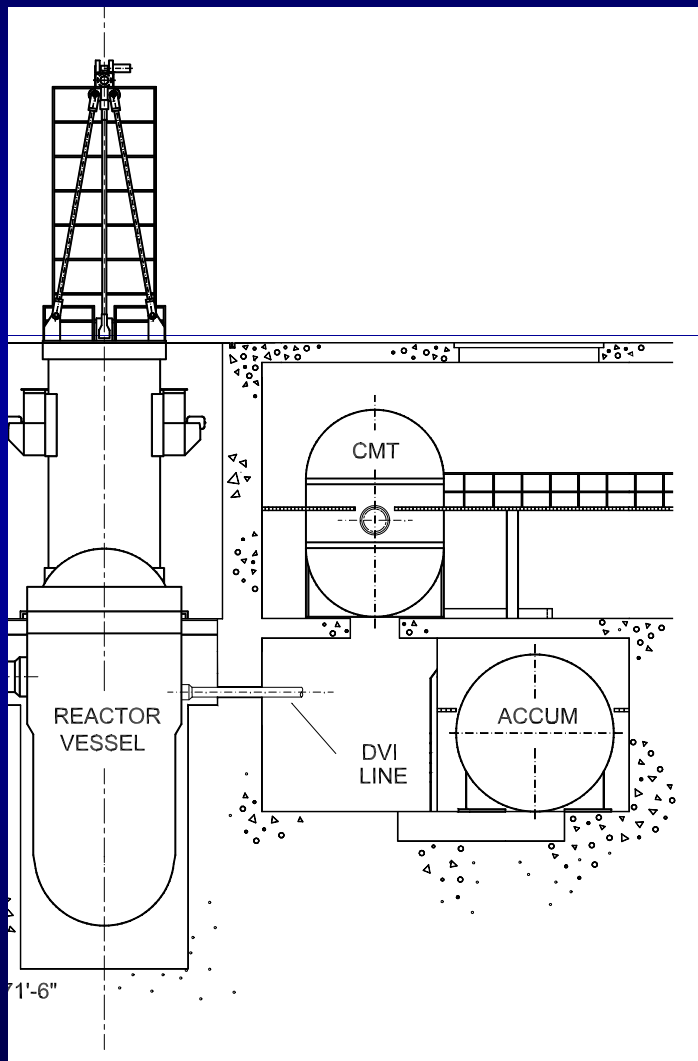

- **Compressed N₂ Provides High Flows**
 - Forces open check valves when RCS pressure decreases < 700 psig (4.9 MPa)
 - Sized to refill RV rapidly in large LOCA
 - Supports small LOCA during ADS
 - Peak flow ~ 1200 lbm/s (544 kg/s) per accumulator with RCS at atmospheric pressure.
 - Injection duration during large LOCA is about 5.5 min
 - When injects rapidly – CMT flow is reduced / stopped due to increased back pressure on CMT



AP1000 IRWST Injection

- The in-containment refueling water storage tank (IRWST) is a large, un-pressurized stainless steel tank below the operating deck.
- Approximately 590,000 gallons (2233 m³) of borated water serve as low-pressure makeup source and heat sink for PRHR HX.
- Connects to both DVI lines.



AP1000 IRWST Injection

- **Compared to AP600, AP1000 IRWST volume and injection capacity increased:**
 - Pipe and valves increased to 8/10” (AP600 6/8”)
 - Eliminated flow tuning balancing orifices
 - Simplifies piping, helps apply larger piping size
 - System can tolerate flow variation without orifice
 - Initial water level increased
 - Added narrow range level sensors to reduce error
 - Flow capacity increased 89%
 - IRWST is enclosed, which limits debris to screens.



IRWST Injection & Cont. Recirc. Piping

AP1000

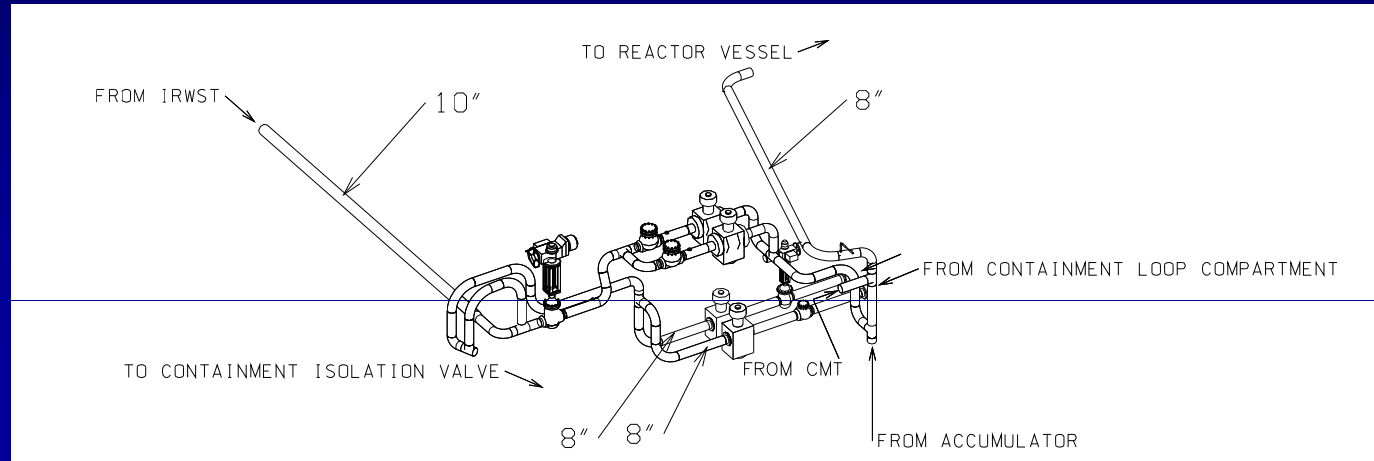

AP600

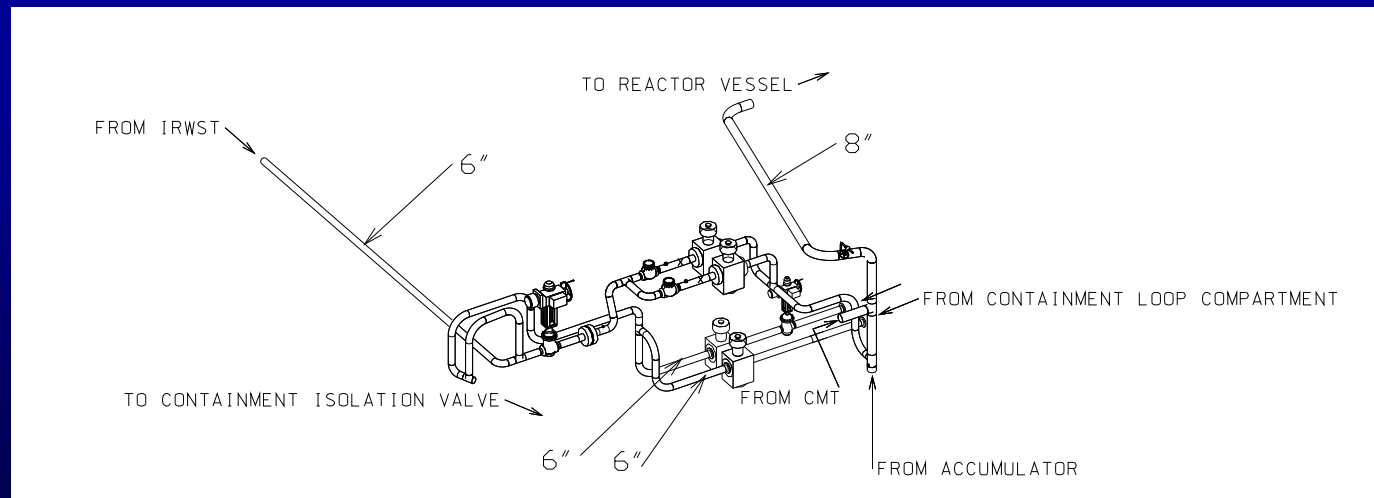



AP1000 Containment Recirculation

● AP1000 Containment Recirc. Capacity Increased

- Pipe and valves increased to 8" (AP600 6/8")
- Containment post ADS water elevation increased
 - DVI LOCA min flood elevation is 108.05' (AP600 106.2')
 - PXS curbs raised to 110.17' (AP600 108.17')
 - Initial IRWST level increased
 - Initial flooding of refueling cavity prevented
 - Check valves added to drain line
 - RNS suction from outside containment
 - Injection suction from Spent Fuel cask loading pit
 - Prevents RNS operation from reducing time for recirc start
 - » By pumping down IRWST during DVI LOCA
- Flow capacity increased 139%



AP1000 Containment Recirculation

● PRA Based Changes

- Recirc MOVs made normally open
 - Improves opening reliability
 - Fewer valves need to open
 - Squib valves are more reliable than MOVs
- Containment Recirc squib diversity
 - AP1000 applies diversity between Cont Recirc paths
 - Recirc paths with MOVs use low pres squib (150 psig)
 - Recirc paths with check valves use high pres squib (2500 psig)
 - » Same squib valve used in IRWST injection lines
 - Improves reliability of Cont. Recirc. and drain for IVR support



Passive Safety Injection Equipment Layout

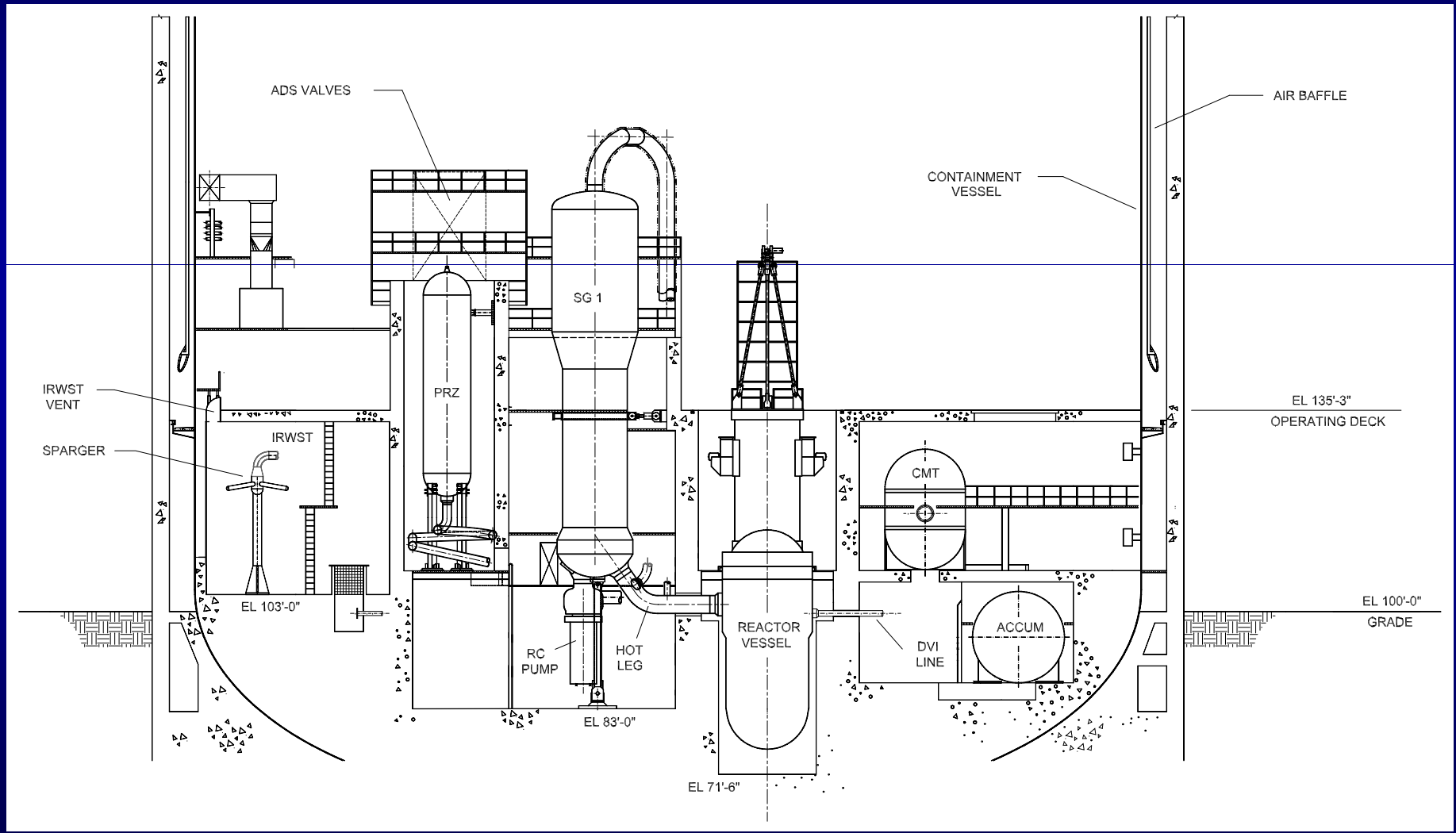



LOCA Long Term Cooling

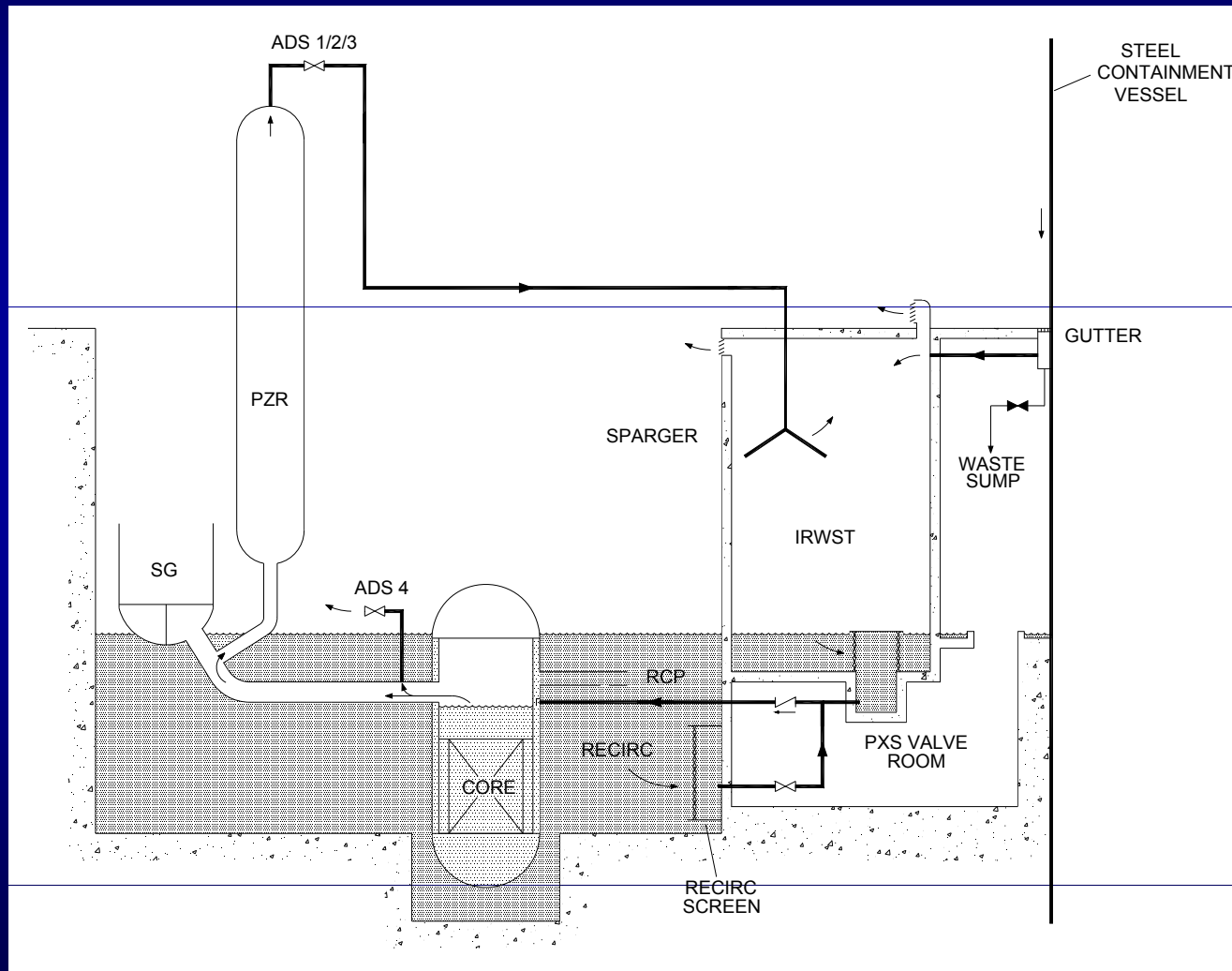



Automatic Depressurization System

- Purpose of the Automatic Depressurization System (ADS) is to progressively decrease RCS pressure to allow passive systems to inject.
- ADS actuates when CMT level decreases below 67.5%. ADS-1/2/3 opens and begins depressurization, discharging from top of pressurizer through spargers into IRWST.
- ADS-4 actuates at 20% CMT level and vents directly to containment. ADS-4 connect to RCS at top of HLs.



Automatic Depressurization System

- **ADS Stages 1,2,3 Not Changed**

- Not important for final RCS depressurization to IRWST Injection and Containment Recirc
- Maintains ADS 1,2,3 piping layout / design, sparger design and IRWST T&H loads

- **ADS Stage 4 Capacity Increased**

- Very important for final RCS depressurization to IRWST / Cont Recirc
- ADS 4 valves / pipe increased to 14" (AP600 10")
 - Common pipe increased to 18" (AP600 12")
- Critical flow area increases 76%
- Subcritical flow increases 93%



Comparison of 4th Stage ADS

AP1000

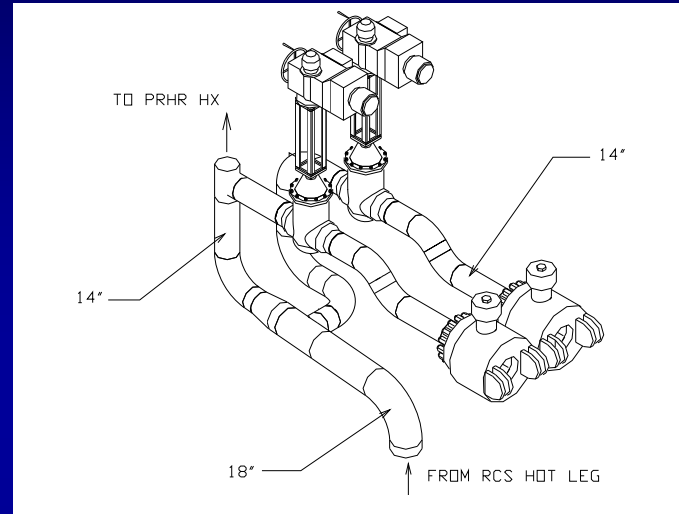

AP600

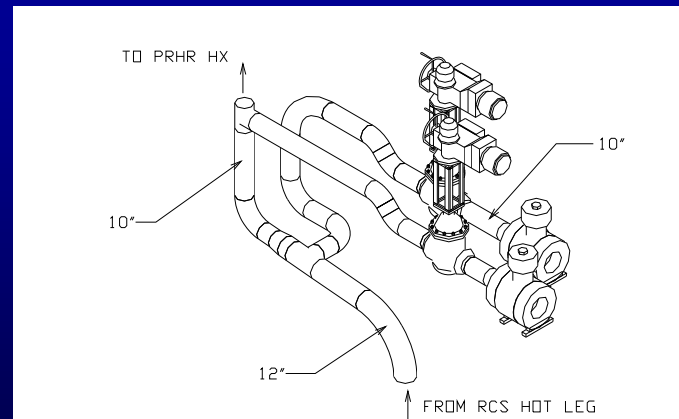



AP1000 ADS 4 Squib Valve (Closed)

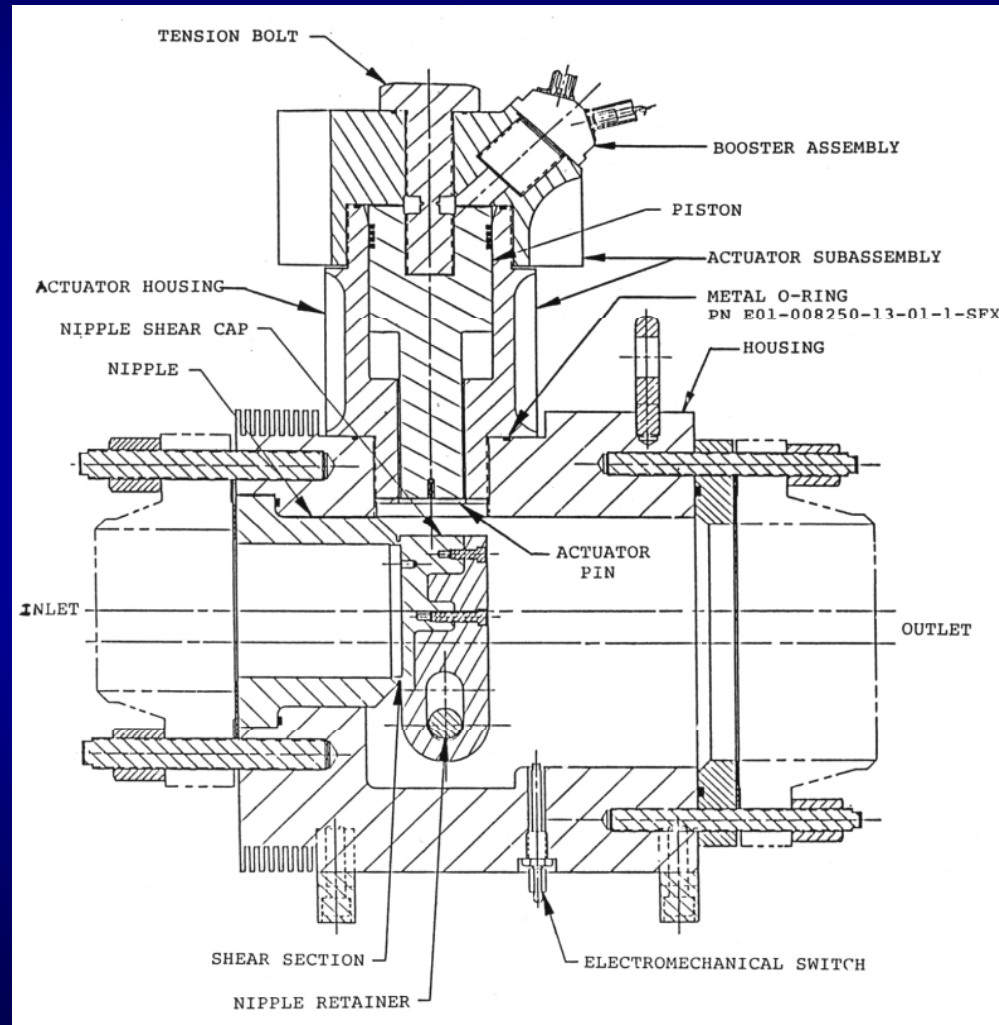



AP1000 ADS 4 Squib Valve (Open)

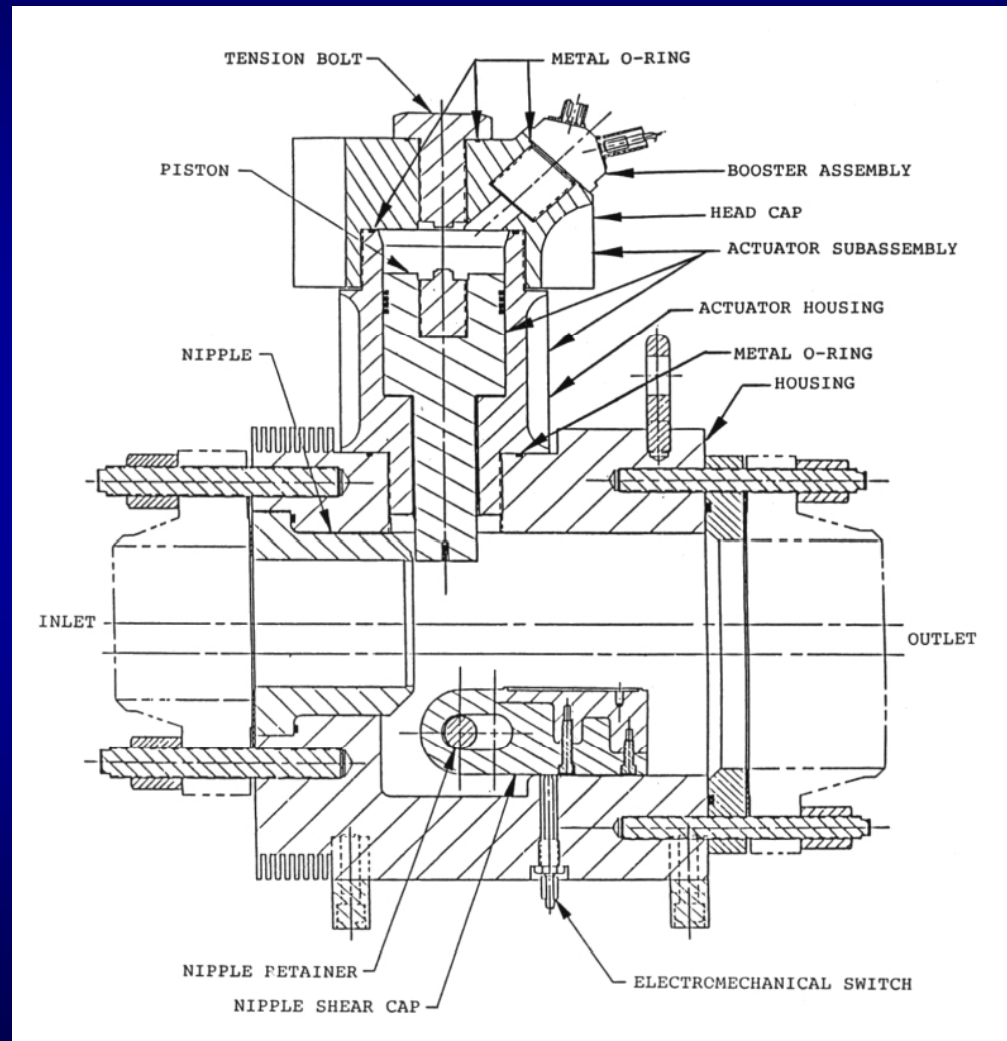



Passive Containment Cooling System

- The passive containment cooling system (PCS) provides the safety-related ultimate heat sink.
- Steel containment shell provides heat transfer surface area to remove heat by continuous natural circulation.
- Air cooling is supplemented by evaporation of water on external surface.



Passive Containment Cooling System

- **PCS Water Storage Tank**
 - Provides 72 hr drain
 - Afterwards use on/offsite water
 - Air only cooling prevents failure
 - Flow decreases with time
 - Uses 4 standpipes
- **PCS Flow Rates**
 - High initial flow
 - Rapidly forms water film
 - Effectively reduces containment pressure
 - Later flows match decay heat cooling

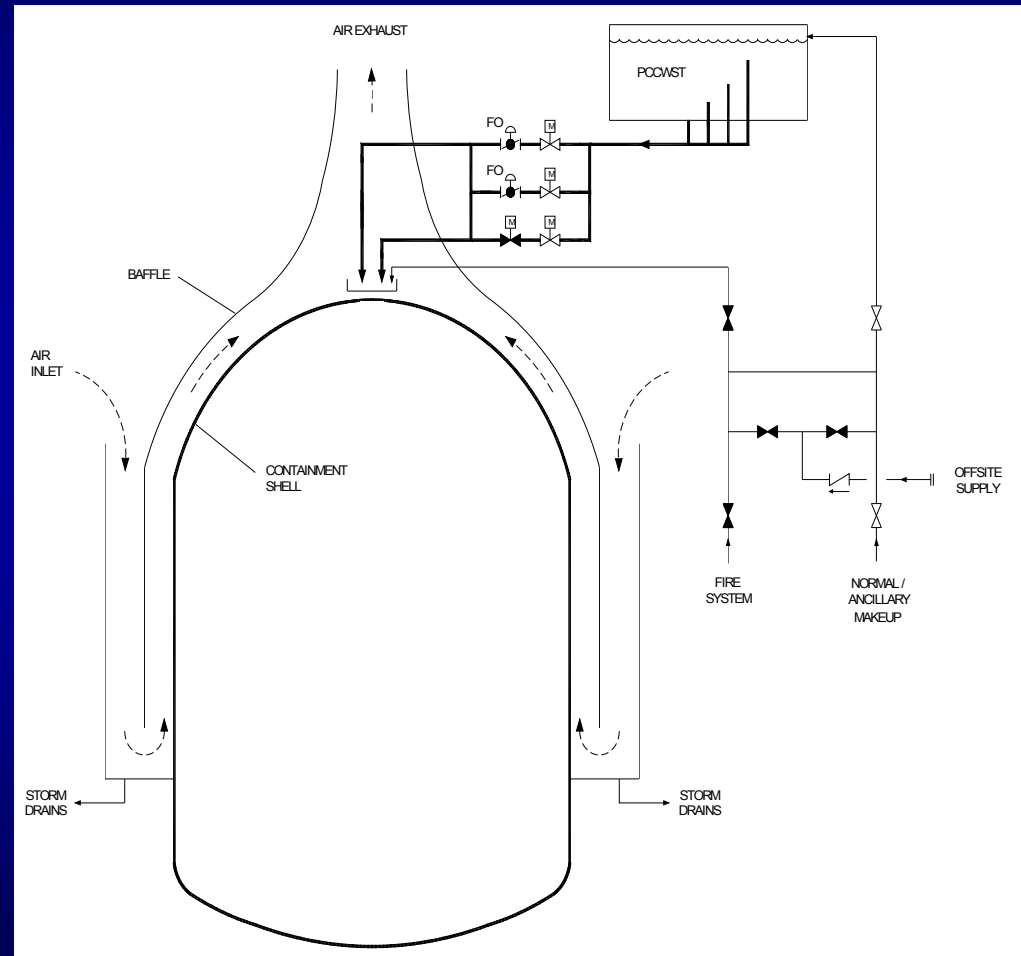



Passive Containment Cooling System

- Same configuration as AP600
- Heat removal capacity increased to accommodate higher power:
 - Larger, higher pressure containment
 - Larger water storage tank
 - Added 3rd, diverse, drain valve

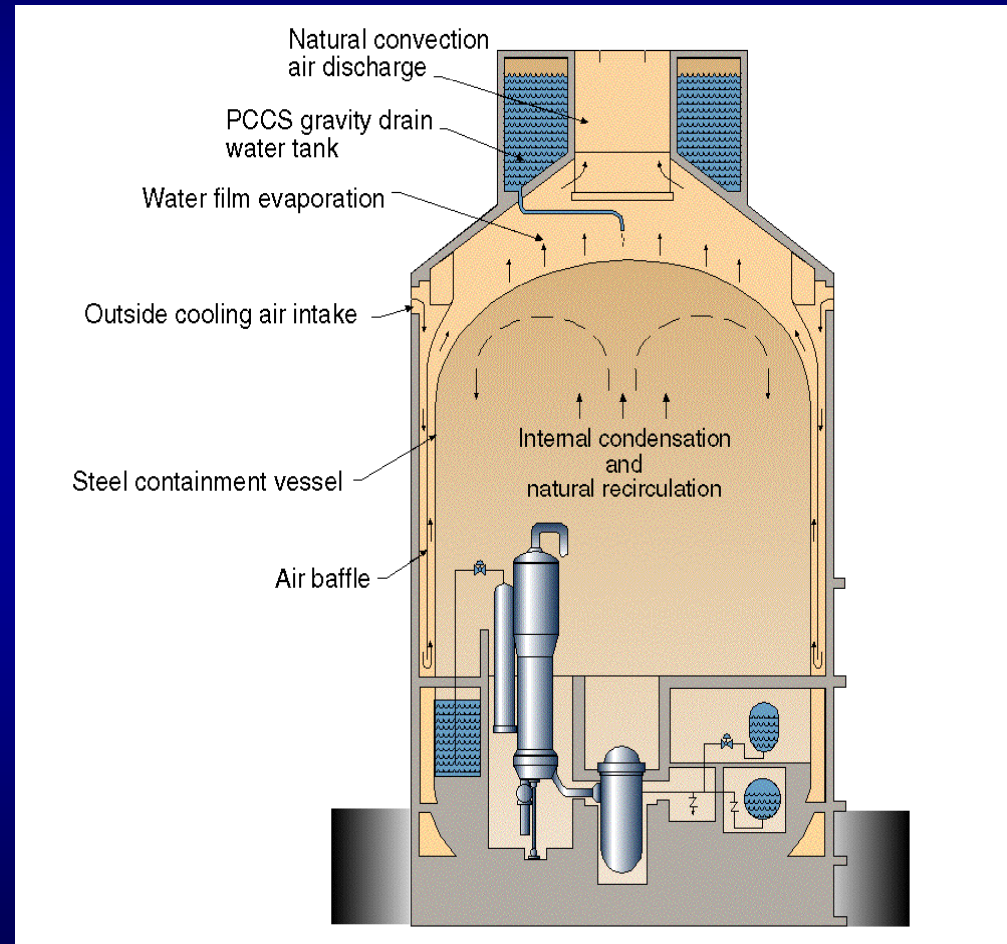



AP1000 Containment Hydrogen Mitigation

● Design Basis Accidents

- Slow long term buildup of H₂
- Uses 2 full size Passive Autocatalytic Recombiners (nonsafety)
 - No power or actuation required
- Equipment is non-safety based on NRC / industry activities on risk-informed changes to 10 CFR 50.44 (Combustible Gas Control)

● Severe Accidents

- Rapid buildup of H₂
- Uses non-safety igniters distributed in pairs around containment
- Release paths from RCS ensure standing H₂ flames located away from containment walls
 - IRWST vents designed to discharge H₂ away from containment wall



AP1000 Containment Recirculation

- **No Fibrous Debris Generated by LOCA**
 - Fibrous debris could create safety challenge
 - Transported to screens, forms mat and filters out smaller particles (crud, dirt)
 - Increases differential pressure, could challenge core cooling
 - Avoided in AP1000; all insulation in LOCA jet zone is reflective metal
- **Enhanced Debris Settling**
 - Deep floodup levels with low flows / velocities
 - Long delay to initiation of recirculation
- **Protective Plates Above Screens**
 - Prevents particles (coating debris) from being transported to screens
- **Coatings Inside Containment**
 - Non-safety related - if detached, will settle before reaching screens
 - Reduced use of coatings inside containment (stairs, cabinets, etc)



Summary

- AP1000 defense in depth uses passive safety systems, to enhance safety and simplify design.
- Redundancy and overcapacity in AP600 safety systems used to achieve increase in power for AP1000.