

Eric A. Larson
Site Vice President

724-682-5234
Fax: 724-643-8069

August 10, 2015
L-15-254

10 CFR 71.95

Mr. Mark Lombard, Director
Division of Spent Fuel Storage and Transportation
Office of Nuclear Material Safety and Safeguards
U.S. Nuclear Regulatory Commission
Washington DC 20555-0001
ATTN: Document Control Desk

SUBJECT:

Beaver Valley Power Station, Unit Nos. 1 and 2
BV-1 Docket No. 50-334, License No. DPR-66
BV-2 Docket No. 50-412, License No. NPF-73
10 CFR 71.95 Report on 8-120B Cask Certificate of Compliance Noncompliance
Due to the use of a Vendor Supplied Neoprene Gasket on the Vent Port Seal.

Dear Mr. Lombard:

FirstEnergy Nuclear Operating Company (FENOC) is submitting this report pursuant to 10 CFR 71.95(a)(3) regarding instances in which the conditions of approval in Certificate of Compliance #9168 for the 8-120B cask may not have been observed when making shipments from Beaver Valley Power Station (BVPS) Unit Nos. 1 and 2. This report is based on a 10 CFR 71.95 report dated June 24, 2015 by the certificate holder, EnergySolutions, to the NRC which is enclosed.

The enclosed notification is applicable to use of the 8-120B cask by BVPS Unit Nos. 1 and 2. FENOC records show that BVPS Unit Nos. 1 and 2 made a total of two Class B shipments using the 8-120B cask from September 2013 through June 2015. Shipment B-4346 was made on 12/17/2013 and shipment B-4487 was made on 3/24/2015. During these shipments the use of a vendor supplied neoprene gasket could have reduced the sensitivity of the vent port seal pre-shipment leak test.

EnergySolutions has replaced the subject gaskets with a modified version that does not have the potential to reduce the test sensitivity and revised the applicable test procedure.

There are no regulatory commitments contained in this submittal. Any actions discussed in this FENOC letter that represent intended or planned actions are described for the NRC's information, and are not regulatory commitments.

LMSS01

Beaver Valley Power Station, Unit Nos. 1 and 2
L-15-254
Page 2

If there are any questions or if additional information is required, please contact Mr. William C. Cothen, Manager, Regulatory Compliance at 724-682-4284.

Sincerely,

A handwritten signature in black ink, appearing to read "E. A. Larson", with a long horizontal flourish extending to the right.

Eric A. Larson

Enclosure: EnergySolutions 10 CFR 71.95 Report on the 8-120B Cask dated
June 24, 2015

cc: Mr. D. H. Dorman, NRC Region I Administrator
Mr. J. A. Krafty, NRC Senior Resident Inspector
Ms. T. A. Lamb, NRR Project Manager
Mr. James Harris, EnergySolutions

Enclosure

L-15-254

EnergySolutions 10 CFR 71.95 Report on the
8-120B Cask dated June 24, 2015
(7 pages follow)

ENERGYSOLUTIONS

June 24, 2015

CD15-0149

Mark Lombard, Director
Division of Spent Fuel Management
Office of Nuclear Material Safety and Safeguards
U.S. Nuclear Regulatory Commission
Washington DC 20555-0001

ATTN: Document Control Desk

Subject: 10 CFR 71.95 Report on the 8-120B Cask

Dear Mr. Lombard:

EnergySolutions hereby submits the attached report providing the information required by 10 CFR 71.95(a)(3) for instances in which the conditions of approval in the Certificate of Compliance for the 8-120B Cask (Certificate of Compliance #9168) may not have been observed in making certain shipments. The circumstances described in this report are applicable to approximately 235 shipments made by *EnergySolutions* as a licensee and user of the 8-120B cask over a 21 month period.

If you have any questions regarding this submittal, please contact me at 801-649-2109.

Daniel B. Shrum

Senior Vice President, Regulatory Affairs
EnergySolutions LLC

Dan Shrum
Jun 24 2015 2:58 PM



Attachment: Failure to Observe Certificate of Compliance Conditions for the 8-120B Vent Port Leak Pre-Shipment Leak Test.

cc: Michele Sampson, Chief
Spent Fuel Licensing Branch

Pierre M. Saverot
Licensing Branch

**Failure to Observe Certificate of Compliance Conditions
for the 8-120B Vent Port Pre-Shipment Leak Test**

June 24, 2015

1) Abstract

During the vent port seal pre-shipment leak rate test, a neoprene gasket that was added under the test manifold may have reduced the test sensitivity below the required value. The test manifold and gasket are not licensed packaging components. The gasket was added to the test manifold on some or all shipments to more reliably seal the manifold, saving test time and reducing personnel exposures. The amount of reduction of the test sensitivity cannot be determined for any particular shipment due to several reasons as discussed below. The gasket may have been used on as many as 100 shipments by *EnergySolutions* as the licensee from September 2013 through June 2015. The condition was determined not to have significant safety consequence because the seals receive periodic helium leak testing as required by the SAR, the vent ports are only opened rarely, there is a margin of conservatism of approximately a factor of 9 on the prescribed vent port leak rate test, and there have been no observations of contamination around the vent port openings that would suggest leakage. There will be no further tests made using the gaskets since *EnergySolutions* has replaced all of the subject gaskets with a modified version that does not have the potential to reduce the test sensitivity.

It is uncertain whether, or by how much, the sensitivity of the vent port pre-shipment leak tests was reduced because: 1) Use of the gasket was optional- the gasket may, or may not have been in place for the tests, and 2) The force with which the gasket was compressed during testing is unknown, so it is uncertain if caused the gasket to constrict onto the head of the vent port cap screw.

2) Narrative Description of the Event

a) Status of Components

All of the 8-120B packaging components are operating normally. The neoprene gaskets that caused the event have all be removed from service and replaced with a new manifold gasket, as discussed in (4) below.

b) Dates of Occurrences

From September 2013, when pre-shipment leak tests were first performed using the neoprene gasket, to present, approximately 100 shipments were made by *EnergySolutions* as the licensee. Most of these shipments used the neoprene gasket to perform the pre-shipment leak rate test of the vent port.

c) Cause of Error

New 8-120B lids went into service in September 2013. It was found that the manifold sometimes had problems sealing with the vent port on these new lids. EnergySolutions personnel found that adding an extra neoprene gasket helped to reduce the false test failures. Since the pre-shipment leak rate test is performed in a radiation environment, false failures are undesirable because they increase the personnel exposure. The personnel did not realize that the gaskets had the potential to reduce the test sensitivity.

Attachment 1 has a detailed description of the test configuration.

d) Failure Mode, Mechanism, and Effects

The neoprene gasket can constrict on the head of the vent port plug cap screw when it is compressed by the bottom end of the test manifold stinger, which could reduce the sensitivity of the pre-shipment leak test. Consequently, the vent port pre-shipment leak tests performed using the neoprene gasket may not have provided the required test sensitivity of 1×10^{-3} ref-cm³/sec.

e) Systems or Secondary Functions Affected
Not applicable.

f) Method of Discovery of the Error

On Monday June 1, 2015, an 8-120B cask user identified a concern that the neoprene gasket could potentially affect the integrity of the vent port seal pre-shipment leak test. Later that week EnergySolutions performed a bench test that confirmed that the neoprene gasket can constrict on the head of the vent port plug cap screw when it is compressed by the manifold, resulting in a reduction of the test sensitivity.

3) Assessment of Safety Consequences

Pre-shipment leak tests of all containment seals, including the vent port, were performed prior to every shipment in accordance with the requirements of Chapter 7 of the SAR. In addition, periodic and maintenance leak tests of the containment seals, using helium as the test gas, were performed after maintenance, repair, or replacement of the containment seals in accordance with the requirements of Chapter 8 of the SAR.

The 8-120B pre-shipment leak rate test criteria were sized for the large primary lid. Since the vent port has a much smaller test volume, the test specification is conservative. Calculations show that the test specified in the SAR is a factor of 9 more sensitive than the 1×10^{-3} ref-cm³/sec required by Chapter 8 of the SAR. However, due to the uncertainties in the effects of the gasket, and the behavior of seals in series, it is not possible to confirm whether the reduction in sensitivity is offset by the test criteria conservatism.

ENERGYSOLUTIONS

There has been no indication of any leakage from the vent port from any shipment, and therefore, no exposure of individuals to radiation or radioactive materials due to the gaskets. It is also noted that it is unusual for the vent port seal to be opened during cask operations, in which case the previous helium leak test of the vent port seal provides added assurance of seal integrity.

Therefore, it is concluded that there has been no safety consequence from performing vent port pre-shipment leak tests that may not have provided the required test sensitivity of 1×10^{-3} ref-cm³/sec.

4) Planned Corrective Actions

EnergySolutions has taken corrective actions to assure that use of the old neoprene gasket design for the vent port pre-shipment leak test is immediately discontinued.

- *EnergySolutions* notified all 8-120B cask users with upcoming shipments to require use of a new procedure, in conjunction with the new manifold gasket design, for pre-shipment leak testing of the vent port seal on all future shipments.
- *EnergySolutions* designed and tested new manifold gasket design that does not constrict onto the head of the vent port plus screw when compressed, and therefore it does not reduce the test sensitivity. The new gaskets have been distributed to all upcoming shipment users. The new manifold gasket design is shown in Attachment 1.

The *EnergySolutions* drawing for the 8-120B air drop manifold have been revised to include the new gasket seal, and the air pressure drop test procedure TR-TP-002 has been revised to incorporate the new pre-shipment leak test procedure for the vent port. Use of the new procedure and the new manifold gasket will assure that the pre-shipment leak test satisfies the required test sensitivity and that the manifold gasket is removed from the test port after completing the pre-shipment leak test.

5) Previous Similar Events Involving the 8-120B

No previous similar events have been identified.

6) Contact for Additional Information

Dan Shrum

EnergySolutions

Senior Vice President, Regulatory Affairs

(801) 649-2109

7) Extent of Exposure of Individuals to Radiation or Radioactive Materials

None.

Attachment 1

Details of the 8-120B Vent Port Leak Rate Test Setup

The 8-120B CoC requires the package to be prepared for shipment and operated in accordance with Chapter 7 of the SAR, and tested and maintained in accordance with Chapter 8 of the SAR. Step 7.1.14 of the SAR requires a pre-shipment leak test of the primary lid, secondary lid, and vent port seals to be performed in accordance with Section 8.3.2.2 prior to every shipment to assure that the containment system is properly assembled. Per Table 8-2 of the SAR, the pre-shipment leak test of the vent port is performed by connecting a test manifold to the vent port, pressurizing the seal and head of the vent port cap screw to 18 psig with dry air or nitrogen, and monitoring the pressure for at least 15 minutes to assure that it does not drop by more than 0.1 psig.

The pre-shipment leak test of the vent port is a pressure drop test performed using a dedicated test manifold. The test manifold is not a part of the licensed package. It includes a stinger (shown below), an O-ring seal that contacts the stinger and the bottom of the vent port hole, and a sleeve nut to compress the O-ring seal. The test manifold was designed so that it surrounds the vent port cap screw, leaving a small gap between itself and the vent port cap screw. The 8-120B cask fleet began to ship with a new lid design in September 2013, and operations staff noted more frequent difficulty getting the manifold to seal. It became desirable to find a better way to seal the bottom of the manifold in order to minimize operator exposure. They found that adding a neoprene gasket (also not part of the licensed package) under the base of the stinger as shown below helped reduce testing time and exposure.

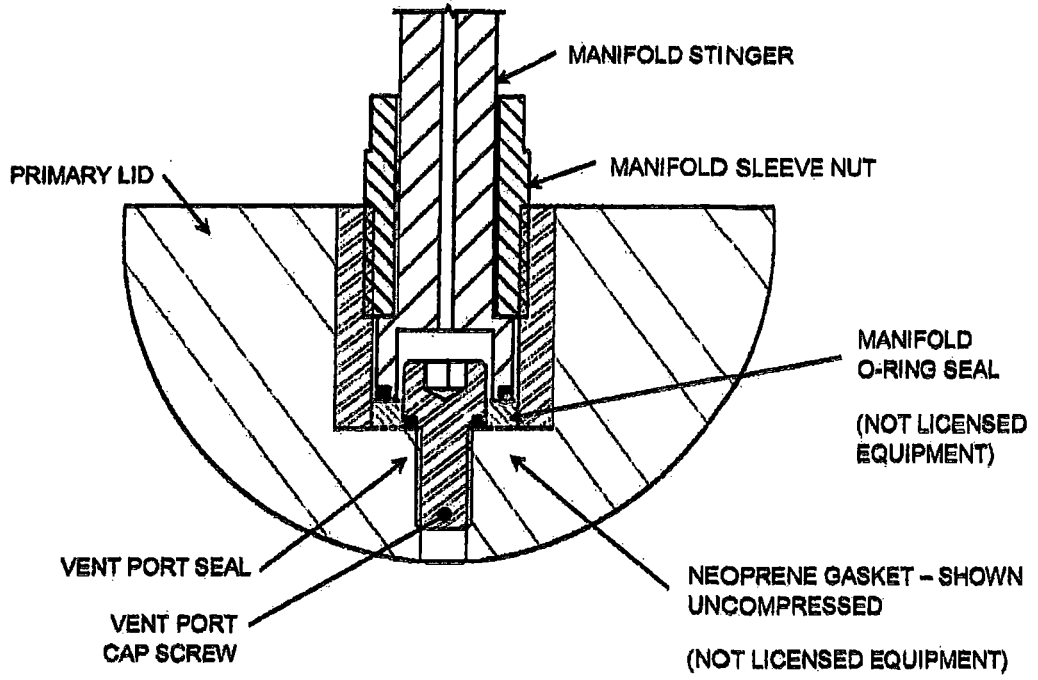

Corrective Action – Modified Test Seal

The new manifold gasket design, shown below, replaces the manifold O-ring seal and neoprene gasket previously used with a neoprene gasket that fits within the notch at the base of the manifold stinger.

