

7.6 All Other Instrumentation Systems Required for Safety

The information in this section of the reference ABWR DCD, including all subsections, tables, and figures, is incorporated by reference with the following departures and supplements.

STD DEP T1 2.3-1 (Figure 7.6-5)

STD DEP T1 2.14-1

STD DEP T1 3.4-1 (Table 7.6-5 and Figures 7.6-1, 7.6-2, 7.6-4a)

STP DEP 1.1-2

STD DEP 1.8-1

STD DEP 7.1-1

STD DEP 7.1-2 (Table 7.6-5)

STD DEP 7.6-1 (Table 7.6-2 and Figures 7.6-2, 7.6-14)

STD DEP 7.6-2

STD DEP 7.6-3 (Figures 7.6-9, 7.6-11)

STD DEP 7.6-4

STD DEP 11.5-1 (Figure 7.6-5)

STD DEP Admin (Table 7.6-1)

7.6.1.1 Neutron Monitoring System-Instrumentation and Controls

STD DEP T1 3.4-1

(1) System Identification

The purpose of the Neutron Monitoring System (NMS) is to monitor power generation and, for the safety function part of the NMS, to provide trip signals to the Reactor Protection System (RPS) to initiate reactor scram under excessive neutron flux (and power) increase condition (high level) or neutron flux fast rising (short period) condition. The NMS also provides power information of operation and control of the reactor to the Plant Process Computer System (PCS) Functions (PCF) and the rod block monitor. A block diagram showing a typical NMS division is shown in Figure 7.6-4a. The operating ranges of the various detectors are shown in Figure 7.6-4b.

7.6.1.1.1 Startup Range Neutron Monitor Subsystem-Instrumentation and Controls

STD DEP T1 3.4-1

(3) *Physical Arrangement*

The 10 detectors are all located at fixed elevation slightly above the midplane of the fuel region, and are evenly distributed throughout the core. The SRNM locations in the core, together with the neutron source locations, are shown in Figure 7.6-1. Each detector is contained within a pressure barrier dry tube inside the core, with signal output exiting the bottom of the dry tube undervessel. Detector cables then penetrate the primary containment and are connected to preamplifiers located in the Reactor Building. The SRNM preamplifier signals are then transmitted to the SRNM ~~DMC (digital measurement and control)~~ units in the control room. The ~~DMC~~SRNM units provide algorithms for signal processing, flux, and power calculations, period trip margin and period calculations, and provide various outputs for local and control console displays, ~~recorder~~, and to the plant ~~process computer system function~~. There are also the alarm and trip digital outputs for both high flux and short period conditions, and the instrument inoperative trip to be sent to the RPS and RCIS separately. The electronics for the SRNMs and their bypasses are located in four separate cabinets.

(4) *Signal Processing*

Over the 10-decade power monitoring range, two monitoring methods are used: (1) for the lower ranges the counting method which covers from $1.E+3$ neutron/cm² to $1.E+9$ neutron/cm², and (2) for the higher ranges, the Campbelling technique (mean square voltage, or MSV) which covers from $1.E+8$ neutron/cm² to $1.E+13$ neutron/cm² of neutron flux. In the counting range, the discrete pulses produced by the sensors are applied to a discriminator after preamplification. The discriminator, together with other digital noise-limiter features, separates the neutron pulses from gamma radiation and other noise pulses. The neutron pulses are then counted. The reactor power is proportional to the count rate. In the MSV range, where it is difficult to distinguish the pulses, a DC voltage proportional to the mean square value of the input signal is produced. The reactor power is proportional to this mean square voltage. In the mid-range overlapping region, where the two methods are changed over, the ~~DMC-based~~SRNM calculates the neutron flux based on a weighted interpolation of the two flux values calculated by both methods. A continuous and smooth flux reading transfer is achieved in this manner. There is also the calculation algorithm of the period-based trip circuitry that generates trip margin setpoint for the period trip protection function.

(6) *Bypasses and Interlocks*

The SRNM also sends an interlock signal to the safety system logic control (SSLC) system. This signal is called "ATWS Permissive" and is a binary signal indicating whether the SRNM power level is above or below a specific setpoint level (Table 7.6-1). If this signal is a "high" level indicating the power

is above the setpoint, this will allow the SSLC to permit ATWS protection action such as permission to inject liquid poison.

7.6.1.1.2 Power Range Neutron Monitor Subsystem—Instrumentation and Controls

7.6.1.1.2.1 Local Power Range Neutron Monitor Subsystem—Instrumentation and Controls

STD DEP T1 3.4-1

STD DEP Admin

(1) *General Description*

The local power range monitor (LPRM) monitors local neutron flux in the power range. The LPRM provides input signals to the APRM Subsystem (Subsection 7.6.1.1.2.2) and to the plant computer ~~system~~function (Subsection 7.7.1.5). See Figures 7.6-1 and 7.6-2.

(4) *Signal Processing*

The LPRM detector outputs are connected by coaxial cables from under the vessel pedestal region and routed through the primary containment penetration, and through the Reactor Building to be processed for signal conditioning analog-to-digital conversion function in the control room. The LPRM signals are connected to the APRM units in the control room, where the signals are amplified. Such amplified voltage is proportional to the local neutron flux level. The LPRM signals are then used by the APRM to produce APRM signals. The 208 LPRM detectors are separated and divided into four groups to provide four independent APRM signals. Individual LPRM signals are also transmitted through dedicated interface units (for isolation) to various systems such as the RCIS, and the plant ~~process~~ computer functions.

(5) *Trip Functions*

The LPRM channels provide alarm signals indicating when an LPRM is upscale, down-scale, or bypassed. However, such signals are not sent to the RPS for scram trip or RCIS for ~~reactor~~rod block.

(7) *Redundancy*

The LPRM detector assemblies are divided into groups. The redundancy criteria are met in the event of a single failure under permissible APRM bypass conditions. A scram signal ~~can be~~is generated in the Reactor Protection System (RPS) as required if the inoperative trip of the APRM is generated as described in (6).

7.6.1.1.2.2 Average Power Range Monitor Subsystem—Instrumentation and Controls

STD DEP T1 3.4-1

STD DEP 7.6-1

(1) *General Description*

(a) *Average Power Range Monitor (APRM)*

The APRMs are safety-related systems. There are four divisions of ~~DMC-based~~ APRM channels located in the control room. Each channel receives 52 LPRM signals as inputs, and averages such inputs to provide a core average neutron flux that corresponds to the core average power. One APRM channel is associated with each trip system of the Reactor Protection System (RPS). However, a trip signal from each APRM division also goes to all other RPS divisions, with proper signal isolation.

(b) *Oscillation Power Range Monitor (OPRM)*

The OPRM is a functional subsystem of the APRM. There are four safetyrelated OPRM channels, with each OPRM channel as part of each of the four APRM channels. Each OPRM receives the identical LPRM signals from the corresponding APRM channel as inputs, and forms a special OPRM cell configuration to monitor the neutron flux behavior of all regions of the core. Each OPRM cell represents a combination of four LPRM signals selected from the LPRM strings at the four corners of a four-by-four fuel bundle square region. The OPRM detects thermal hydraulic instability and provides trip functions to the RPS to suppress neutron flux oscillation prior to the violation of safety thermal limits. The OPRM trips are ~~combined with~~ separate from the APRM trips of the same APRM channel; ~~to be sent to the RPS.~~

(4) *Trip Function*

For the OPRM trip function, the response signal of any one OPRM cell that satisfies the conditions and criteria of the trip algorithm will cause a trip of the associated OPRM channel. Figure 7.6-14 illustrates the trip algorithm logic. ~~The OPRM trip function does not have its own inoperative trip for insufficient number of total LPRM inputs in the channel. It follows the APRM's inoperative trip of insufficient number of LPRMs.~~ The OPRM function has its own inoperative trip when the channel has less than the required minimum operable cells, when there is an OPRM self-diagnostic fault, when the APRM instrument watchdog timer has timed out, or if there is a loss of power to the APRM instrument.

(5) *Bypasses and Interlocks*(a) *APRM*

The APRM also sends an interlock signal to the ~~SSLG ELCS~~ similar to the ~~SRNM “ATWS Permissive”~~ signal (Table 7.6-2). If this signal is a “high” level indicating the power is above the setpoint, this will allow the ~~SSLG ELCS~~ to permit ATWS protection action.

(6) *Redundancy*(b) *OPRM*

There are four independent and redundant OPRM channels. The above APRM redundancy condition also applies to OPRM since each OPRM channel is associated with one RPS division. ~~is a subsystem of each of the four APRM channels. The OPRM trip outputs are provided separately from the APRM trips to RPS and also follow the RPS two-out-of-four logic as the APRM since the OPRM trip outputs are combined with other APRM trip outputs in each APRM channel to provide the final trip outputs to the RPS.~~ In addition, each LPRM string with four LPRM detectors provides one LPRM input to each of the four independent and redundant OPRM channels. This provides core regional monitoring by redundant OPRM channels.

(7) *Testability*

APRM channels are calibrated using data from previous full-power runs and are tested by procedures in the instruction manual. Each APRM channel can be tested individually for the operability of the APRM scram and rod-blocking functions by introducing test signals. This includes the test for the OPRM trip function. A self-testing feature ~~similar to that described for SSLG~~ is also provided.

7.6.1.1.3 Reactor Operator Information

STD DEP Admin

The man-machine interface of the Neutron Monitoring System provides for the information and controls described in this subsection. The lists provided in Table ~~7.6-3~~ 7.6-5 consist of major signal information which is also documented in the system IED (Figure 7.6-1) and the system IBD (Figure 7.6-2).

7.6.1.2 Process Radiation Monitoring System – Instrumentation and Controls

STD DEP T1 2.3-1

The process radiation subsystems are shown in the system design IED (Figure 7.6-5). Subsystems (4~~2~~) through (4) are classified nuclear safety-related, while subsystems

(1) and (5) through (11) are classified as non-safety-related. System descriptions and requirements are described in detail in Section 11.5.

7.6.1.3 High Pressure/Low Pressure Systems Interlock Protection Functions

STD DEP 7.1-1

(14) Setpoints

~~See Chapter 16 for setpoints and margin.~~ Chapter 16 describes the methods for calculating setpoints and margins.

7.6.1.6 Containment Atmospheric Monitoring (CAM) System-Instrumentation and Controls

STD DEP T1 2.14-1

STD DEP 11.5-1

(1) System Identification

~~The CAM System (Figures 7.6-7 and 7.6-8) consists of two independent but redundant Class 1E divisions (I and II) of radiation channels, which are electrically and physically separated, and a non-safety H₂/O₂ monitoring subsystem. Each CAM division divisional radiation channel has the capability of monitoring the total gamma-ray dose rate. CAMS also has the capability of monitoring and concentration of hydrogen and oxygen (H₂/O₂) in the drywell and/or the suppression chamber during plant operation, and following a LOCA event.~~

~~There are two radiation monitoring channels per division; one for monitoring the radiation level in the drywell and the other for monitoring the radiation level in the suppression chamber. Each monitoring channel consists of an ion chamber a detector, and a digital log radiation monitor, and a recorder. Each radiation monitoring channel provides alarm indication in the control room on high radiation levels and also if the channel becomes inoperative. The monitor also provides data for the historian function.~~

~~The H₂/O₂ monitoring subsystem has two channels and consists Each divisional H₂/O₂ monitoring channel consists of valves, pumps, and pipes used to extract samples of the atmosphere in the drywell or the suppression chamber and feed the extracted air sample into an analyzer and monitor for measurement, recording, and for alarm indication on high concentration of gas levels. The H₂/O₂ monitoring subsystem is non-safety and is physically and electrically separate from the safety-related components of the system.~~

~~The piping used for the gas extraction is made of stainless steel and utilizes heat tracing to keep the pipes dry and free of moisture condensation.~~

(2) Power Sources

~~Each CAM Subsystem radiation channel is powered from divisional 120 VAC instrument bus. The same Class 1E divisional 120 VAC power source also supplies the heat tracing blanket used for the sampling lines. The H₂/O₂ subsystem is powered from non-safety equipment.~~

(3) Initiating Circuits

~~Each divisional gamma radiation monitoring channel can be energized manually by the operator, or automatically by the LOCA signal. For the manual mode, the~~ The gamma radiation monitor is on continuously during plant operation and remains on until power is turned off by the operator.

~~In the power off mode, the channel will be activated automatically in the presence of a LOCA (high drywell pressure or low reactor water level).~~

~~Each divisional H₂/O₂ monitoring subsystem channel (except for the two sampling pumps) is powered continuously during plant operation. One pump~~ Each subsystem channel is controlled by an operator and is used during reactor operation and ~~the other is~~ can also be turned on by the LOCA signal to allow measurement during an accident.

The heat tracing used in each H₂/O₂ sample line is temperature controlled to prevent moisture condensation in the pipes.

~~Each divisional H₂/O₂ analyzer and monitor can selectively measure the atmosphere in the drywell or the suppression chamber.~~

~~Division I and II LOCA signals are provided to the CAM System from the RHR System. These signals are based on two-out-of-four logic signals for the high drywell pressure or low reactor water level.~~

(4) Redundancy and Diversity

The CAM Subsystems, Divisions I and II radiation channels, are independent and are redundant to each other.

(5) Divisional Separation

The two CAM ~~Subsystems~~ radiation monitoring channel divisions are electrically and physically separated so that no single design basis event is capable of damaging equipment in more than one CAM division. No single failure or test, calibration, or maintenance operation can prevent function of more than one division.

(7) *Environmental Consideration*

The CAM System radiation monitoring channels ~~are~~ *is* qualified Seismic Category I and ~~is~~ *are* designed for operability during normal and post-accident environments.

(8) *Operational Considerations*

The following information is available to the reactor operator:

- (a) Each gamma radiation channel consists of ~~an ion chamber~~ a detector and a log radiation monitor, ~~and a recorder~~. Each channel has a range of 0.01 ~~Cy/h~~ Sv/h to 10^5 Sv/h ~~Cy/h~~. Each channel will initiate an alarm on high radiation level or on an inoperative channel.
- (b) Each hydrogen/oxygen monitoring ~~channel~~ uses subsystem channel contains a sampling rack for extracting the atmosphere from the drywell or the suppression chamber and for analyzing the contents for both H₂/O₂ concentration. The gaseous measurements are made by volume on a wet basis after humidity correction (dry basis before humidity correction). Separate monitors are provided for oxygen and hydrogen indications.

Each H₂/O₂ analyzer ~~rack~~ has a series of subsystem channel has alarms to indicate a high concentration of hydrogen and of oxygen, and to alert the operator of any abnormal system parameter. Refer to Figure 7.6-8 for definition of these alarms.

7.6.1.7 Suppression Pool Temperature Monitoring System-Instrumentation and Controls

7.6.1.7.1 System Identification

STD DEP 7.6-2

The Suppression Pool Temperature Monitoring (SPTM) System is a subsystem of the Reactor Trip and Isolation System (RTIS). It is provided to monitor suppression pool temperature. Monitoring of suppression pool temperature is provided so that trends in suppression pool temperature may be established in sufficient time for proper cooling of the suppression pool water and for reactor scram due to high suppression pool temperature and for reactor power control based upon symptom-based emergency operating procedures.

7.6.1.7.3 Equipment Design

STD DEP T1 3.4-1

STD DEP 7.6-3

The SPTM System configuration is shown in Figures 7.6-9 and 7.6-10. There are eight temperature circumferential sensor locations (Figure 7.6-9), which are chosen based upon the following considerations:

- (2) Each SRV discharge line quencher is in direct sight of two sets of temperature sensors within 9 meters.

Electrical wiring for each sensor is terminated, for sensor replacement or maintenance, in the wetwell. This termination is sealed for moisture protection from condensation or wetwell sprays. Division I, II, III and IV sensors are wired through Division I, II, III or IV electrical penetrations, respectively. ~~Division I, II, III or IV I and II sensor signals are wired to for the Remote Shutdown System are directly hardwired. all sensor signals multiplexed to the main control room via the respective Division I, II, III or IV essential multiplexers.~~

7.6.1.7.9 Signal Processing

STD DEP T1 3.4-1

Processing of temperature signals is performed by a ~~microprocessor~~ configurable logic device for each instrument division. For each of the four instrument divisions, the temperature signals are arithmetically averaged to yield an average bulk suppression pool temperature. Provisions are incorporated to detect sensor failures. When failure of a sensor is detected, its output is not added to the sum of all other sensors in the division and the number of sensors is correspondingly reduced in computing the average temperature. In addition, the narrow range suppression pool water level signal from the Atmospheric Control System (ACS) is used to detect uncovering of the first set of sensors below the pool surface. After sensor installation, the elevation for each sensor is to be established with respect to a common reference elevation. When the suppression pool water level drops below the elevation of a particular sensor, that sensor signal is not used in computing the average. The wide range level signal from the ACS is utilized for this purpose for the remaining sensors.

7.6.2 Analysis

7.6.2.1 Neutron Monitoring System—Instrumentation and Controls

7.6.2.1.1 General Functional Requirements Conformance

STD DEP 7.6-4

- (2) Power Range Neutron Monitors (PRNM)

The PRNM Subsystem provides information for monitoring the average power level of the reactor core and for monitoring the local power level when the reactor power is in the power range (above approximately ~~45%~~ 5% power). It mainly consists of the LPRM and the APRM Subsystems.

7.6.2.1.2 Specific Regulatory Requirements Conformance

STP DEP 1.1-2

STD DEP 1.8-1

STD DEP Admin

- (1) 10CFR50.55a (IEEE- ~~279603~~):

There are 52 LPRM assemblies evenly distributed in the core. There are four LPRM detectors on each assembly, evenly distributed from near the bottom of the fuel region to near the top of the fuel region (Figure 7.6-3). A total of 208 detectors are divided and assigned to four divisions for the four APRMs. Any single LPRM detector is only assigned to one APRM division. Electrical wiring and physical separation of the division is optimized to satisfy the safety-related system requirement. With the four divisions, redundancy criteria are met, since a scram signal can still be initiated with a postulated single failure under allowed APRM bypass conditions. The OPRM subsystem as described in Subsection 7.6.1.1.2.2 conforms to all applicable requirements of IEEE- ~~279603~~.

All applicable requirements of IEEE- ~~279603~~ are met with the NMS.

- (4) Branch Technical Positions (BTPs)

In accordance with the Standard Review Plan for Section 7.6, and with Table 7.1-2, only BTPs 21 and 22 are considered applicable for the NMS. They are addressed as follows:

- (a) BTP ICSB 21- "Guidance for Application of Regulatory Guide 1.47"

The ~~ABWR design is a single unit~~ two units do not share NMS equipment. Therefore, Item B-2 of the BTP is not applicable. Otherwise, the NMS is in full compliance with this BTP.

7.6.2.2 Process Radiation Monitoring System—Instrumentation and Controls

7.6.2.2.2 Specific Regulatory Requirements Conformance

STP DEP 1.1-2

STD DEP 1.8-1

- (1) 10CFR50.55a (IEEE- ~~279603~~):

Electrical separation is maintained between the redundant divisions. All applicable requirements of IEEE- ~~279603~~ are met by the safety-related subsystem of the PRM System.

(4) Branch Technical Positions (BTPs)

In accordance with the Standard Review Plan for Section 7.6, and with Table 7.1-2, only BTPs 21 and 22 are considered applicable for the PRM safety-related subsystems. They are addressed as follows:

(a) BTP ICSB 21- "Guidance for Application of Regulatory Guide 1.47"

The ~~ABWR design is a single unit~~ two units do not share PRM equipment. Therefore, Item B-2 of the BTP is not applicable. Otherwise, the PRM System is in full compliance with this BTP.

7.6.2.3 High Pressure/Low Pressure Systems Interlock Function**7.6.2.3.2 Specific Regulatory Requirements Conformance**

STD DEP 1.8-1

(1) 10CFR50.55a (~~IEEE-279603~~)

The HP/LP interlocks are an integral part of the RHR System, which is designed to meet the requirements of ~~IEEE-279603~~ as discussed in Subsections 7.4.2.3.2 and 7.3.2.1.2.

7.6.2.6 Containment Atmospheric Monitoring System—Instrumentation and Controls**7.6.2.6.2 Specific Regulatory Requirements Conformance**

STD DEP T1 2.14-1

STP DEP 1.1-2

STD DEP 1.8-1

(1) 10CFR50.55a (~~IEEE- 279603~~)

The safety related CAMS radiation channels ~~consists~~ of two divisions which are redundantly designed so that failure of any single element will not interfere with the system operation. Electrical separation is maintained between the redundant divisions.

The CAMS does not actuate or interface with the actuation of another safety-related system. Therefore, any portion of ~~IEEE- 279603~~ which pertains to such interfaces is not applicable. All other applicable requirements of ~~IEEE- 279603~~ are met with the CAMS.

(4) Branch Technical Positions (BTPs)

In accordance with the Standard Review Plan for Section 7.6, and with Table 7.1-2, only BTPs 21 and 22 are addressed for the CAMS as follows:

(a) BTP ICSB 21- “Guidance for Application of Regulatory Guide 1.47”

The ~~ABWR design is a single unit~~ two units do not share CAMS equipment. Therefore, Item B-2 of the BTP is not applicable. Otherwise, the CAMS is in full compliance with this BTP.

7.6.2.7 Suppression Pool Temperature Monitoring System—Instrumentation and Controls**7.6.2.7.2 Specific Regulatory Requirements Conformance**

STP DEP 1.1-2

STD DEP 1.8-1

(1) 10CFR50.55a (IEEE- ~~279603~~)

The SPTM system continuously operates during the plant operation. It does, however, automatically initiate RHR for suppression pool cooling and generates four divisional trip signals for RPS. Therefore, the portions of IEEE- ~~279603~~ which pertain to actuation of safety functions apply through RHR and RPS. All other applicable requirements of IEEE- ~~279603~~ are met with the SPTM system.

(4) Branch Technical Positions (BTPs)

In accordance with the Standard Review Plan for Section 7.6, and with Table 7.1-2, only BTPs 21 and 22 need be addressed for the SPTM System. They are as follows:

(a) BTP ICSB 21- “Guidance for Application of Regulatory Guide 1.47”

The ~~ABWR design is a single unit~~ two units do not share SPTM equipment. Therefore, Item B-2 of the BTP is not applicable. Otherwise, the SPTM System is in full compliance with this BTP.

7.6.3 COL License Information**7.6.3.1 APRM Oscillation Monitoring Logic**

The following standard supplement addresses COL License Information Item 7.2.

There are no departures from the fuel design licensing basis that are described in the reference ABWR DCD, including the core thermal hydraulic design described in Section 4.4. The APRM oscillation logic is designed in accordance with the BWR Owners Group Stability Option III and described in Subsection 7.6.1.1.2.2.

Table 7.6-1 SRNM Trip Function Summary

Trip Function	Trip Setpoint (Nominal)	Action
SRNM Short Period Trip	11 seconds	Scram [‡] (bypassed in RUN & REFUEL) (no scram function in counting range)
SRNM Period Withdrawal Permissive	56 seconds	Warning ^f (bypassed in RVN/RUN)

‡ Scram action only active in MSV range, which is defined as above 1 x 10⁻⁴% power.

^f Conditions for activation will be defined in the technical specifications.

Table 7.6-2 APRM Trip Function Summary

Trip Function	Trip Setpoint (Nominal)	Action
(b) OPRM Trip Function		
Period-Based Trip (S_P)	$S=S_P=1.10^{**}$	Scram <i>f</i>
OPRM Inoperative Trip	<ol style="list-style-type: none"> 1. LPRM input too few 2. Self-test fault 3. Watchdog timer timed out 4. Loss of power 	Scram <i>f</i>

** Other Pre-Trip Condition parameters of the algorithm are:

$T_{\min}=1$ s, $T_{\max}=3.5$ s, $\pm t_{\text{error}}=0.15$ s **[0.100 - 0.300s]**, $N_P=10$.
 (For details see Figure 7.6-14).

Table 7.6-5 Reactor Operator Information for NMS

(4) Certain NMS-related information, available on the main control panel, is implemented in software which is independent of the process computer plant computer functions . This information is listed below.
(5) CRT VDU displays, which are part of the performance monitoring and control system, provide certain NMS-related displays and controls on the main control panel which are listed below:
(ii) SRNM ATWS permissive
(qq) APRM ATWS permissive
Acronyms CRT <i>Cathode Ray Tube</i> VDU Video Display Unit

The following figures are located in Chapter 21:

- Figure 7.6-1 Neutron Monitoring System IED (Sheets 1 - 4)
- Figure 7.6-2 Neutron Monitoring System IBD (Sheets 1, 9,9a, 9b, 14)
- Figure 7.6-5 Process Radiation Monitoring System IED (Sheets 1 - 10)
- Figure 7.6-11 Suppression Pool Temperature Monitoring System IED (Sheets 1, 3)

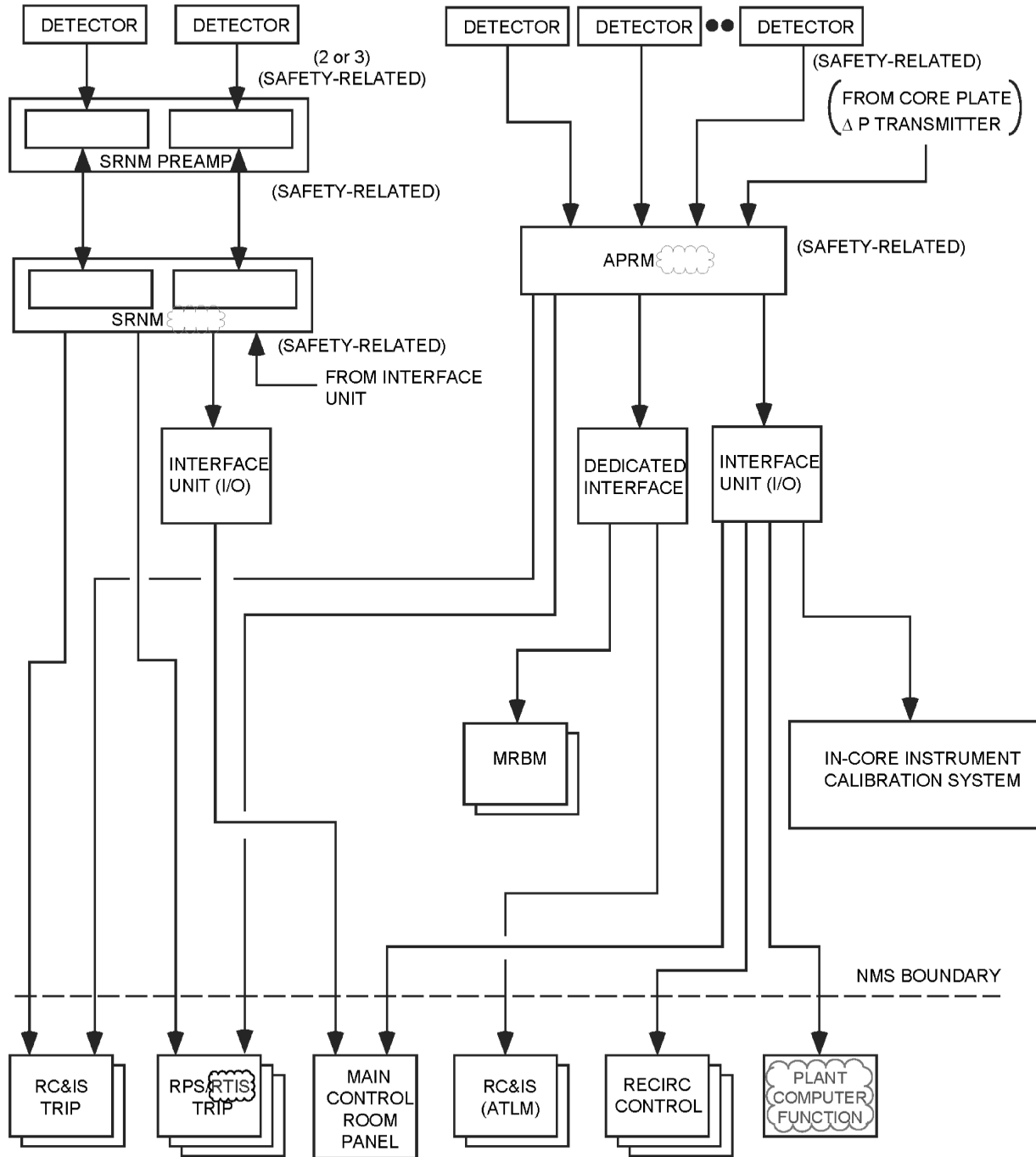
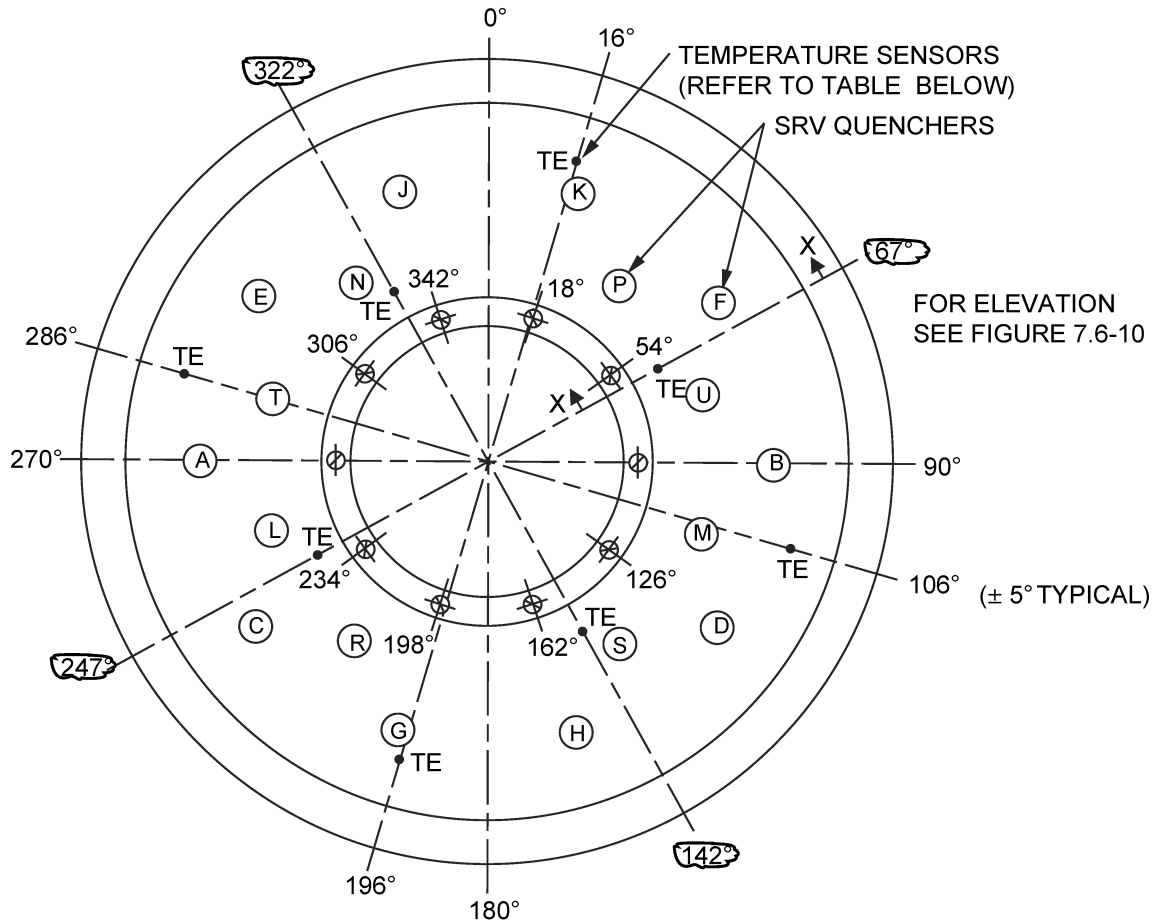

Figure 7.6-4a Basic Configuration of a Typical Neutron Monitoring System Division



	DIVISION I	DIVISION II	DIVISION III	DIVISION IV
16°	TE-001A,E,J,N		TE-001C,G,L,R	
67°		TE-002B,F,K,P		TE-002D,H,M,S
106°		TE-003B,F,K,P		TE-003D,H,M,S
142°	TE-004A,E,J,N		TE-004C,G,L,R	
196°	TE-005A,E,J,N		TE-005C,G,L,R	
247°		TE-006B,F,K,P		TE-006D,H,M,S
286°		TE-007B,F,K,P		TE-007D,H,M,S
322°	TE-008A,E,J,N		TE-008C,G,L,R	

Figure 7.6-9 Instrumentation Location Definition for the Suppression Pool Temperature Monitoring System

Amplitude & Growth Rate Based Detection Algorithm

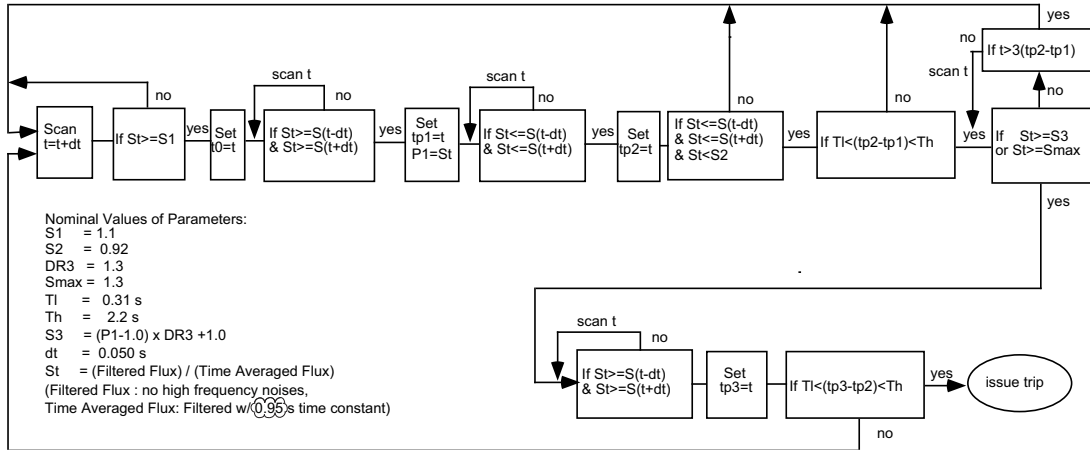

Period Based Detection Algorithm

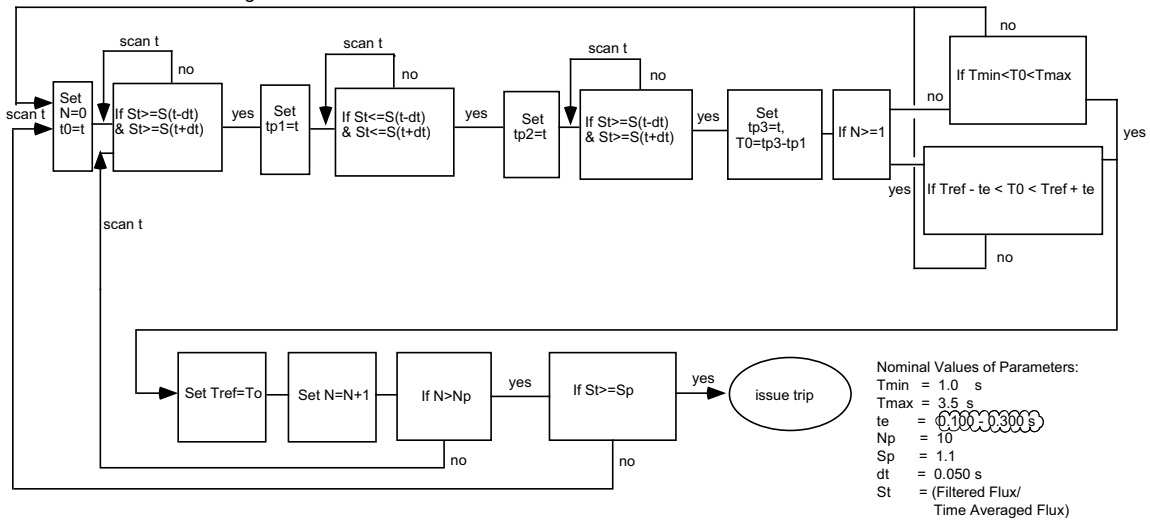

Figure 7.6-14 OPRM Logic

