

Figure 9a2.1-1 – RVZ1 Ventilation Flow Diagram

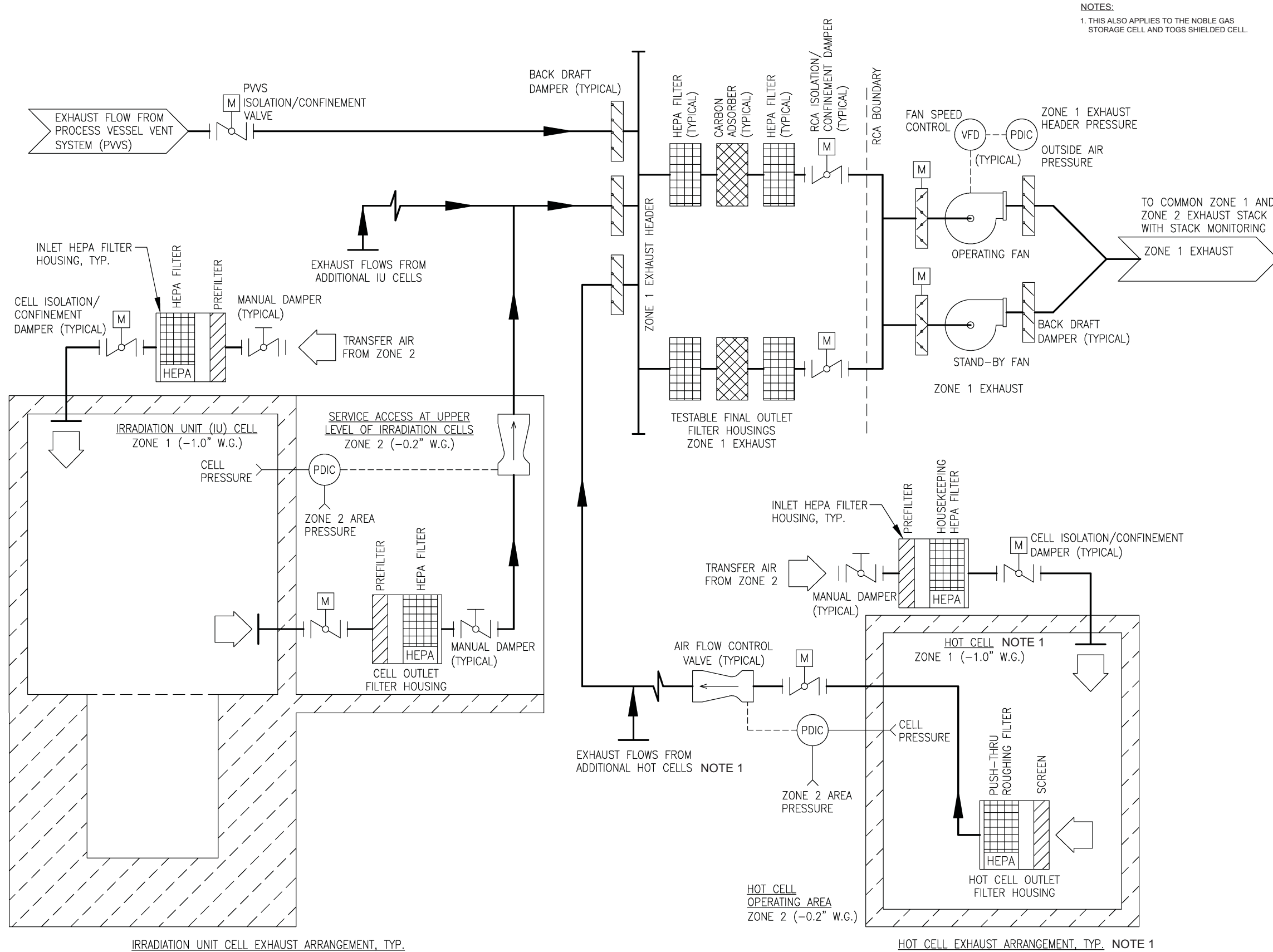

Figure 9a2.1-2 – RVZ2SA and RVZ2 Ventilation Flow Diagram

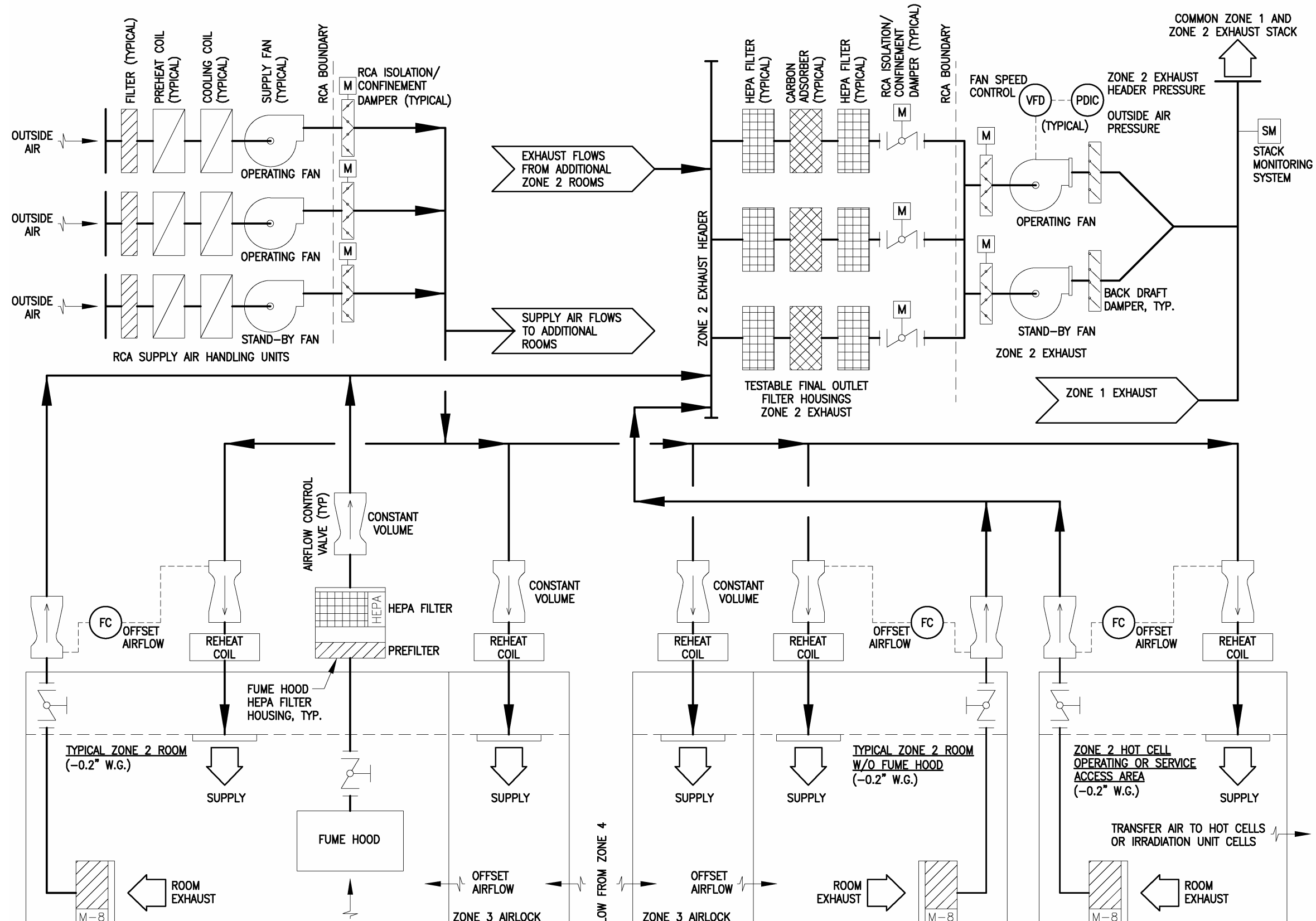
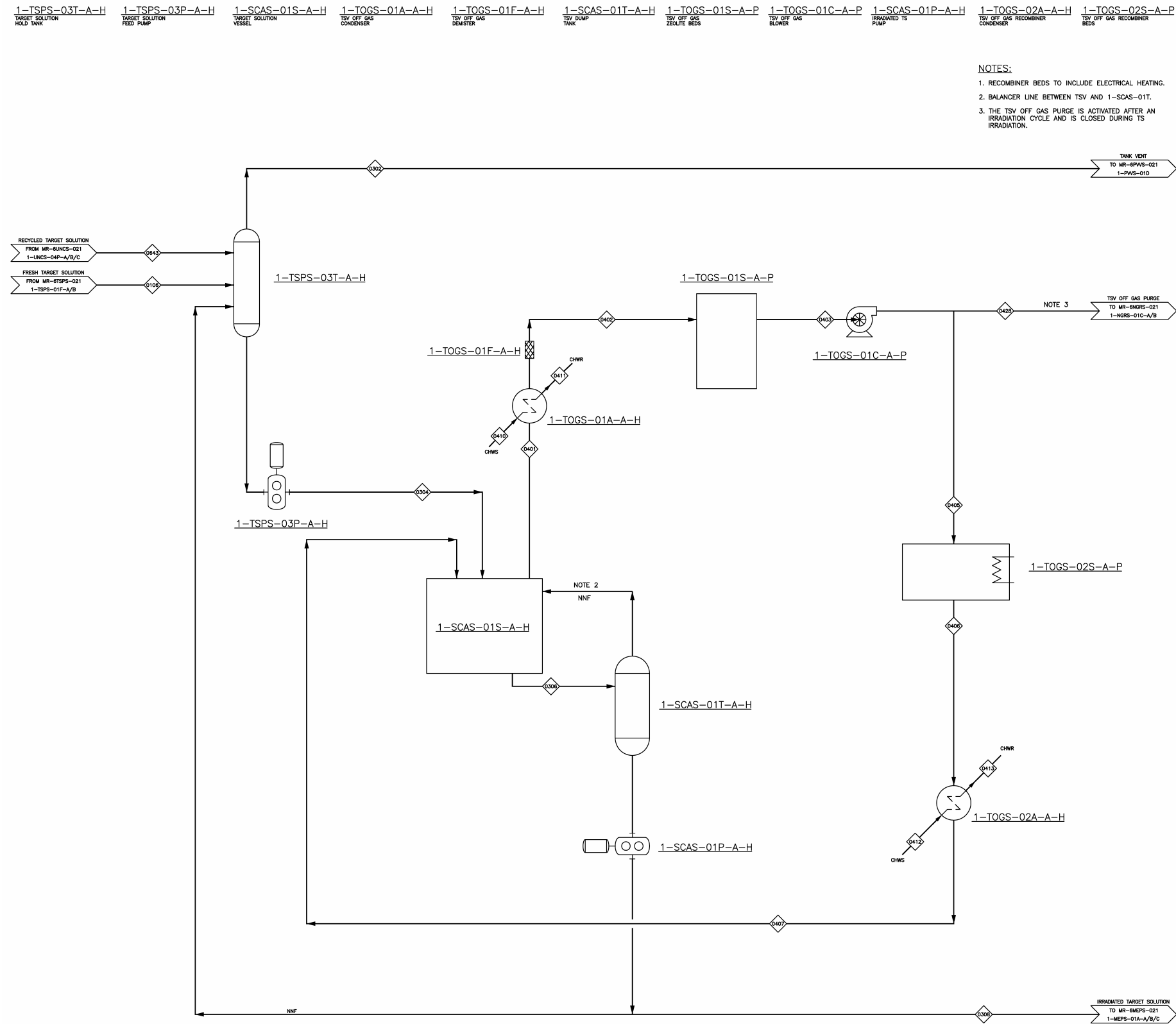

Figure 9a2.2-1 – Irradiation Facility Target Solution Storage and Handling Process Flow Diagram



DRAWING SCALE

Figure 9a2.2-2 – Subcritical Assembly Cross-Section

Proprietary Information – Withhold from public disclosure under 10 CFR 2.390(a)(4)
Security-Related Information – Withhold Under 10 CFR 2.390

Figure 9a2.3-1 – Fire Area and Fire Zone Boundaries

Proprietary Information – Withhold from public disclosure under 10 CFR 2.390(a)(4)
Security-Related Information – Withhold Under 10 CFR 2.390

Figure 9a2.3-2 – Fire Protection Site Layout

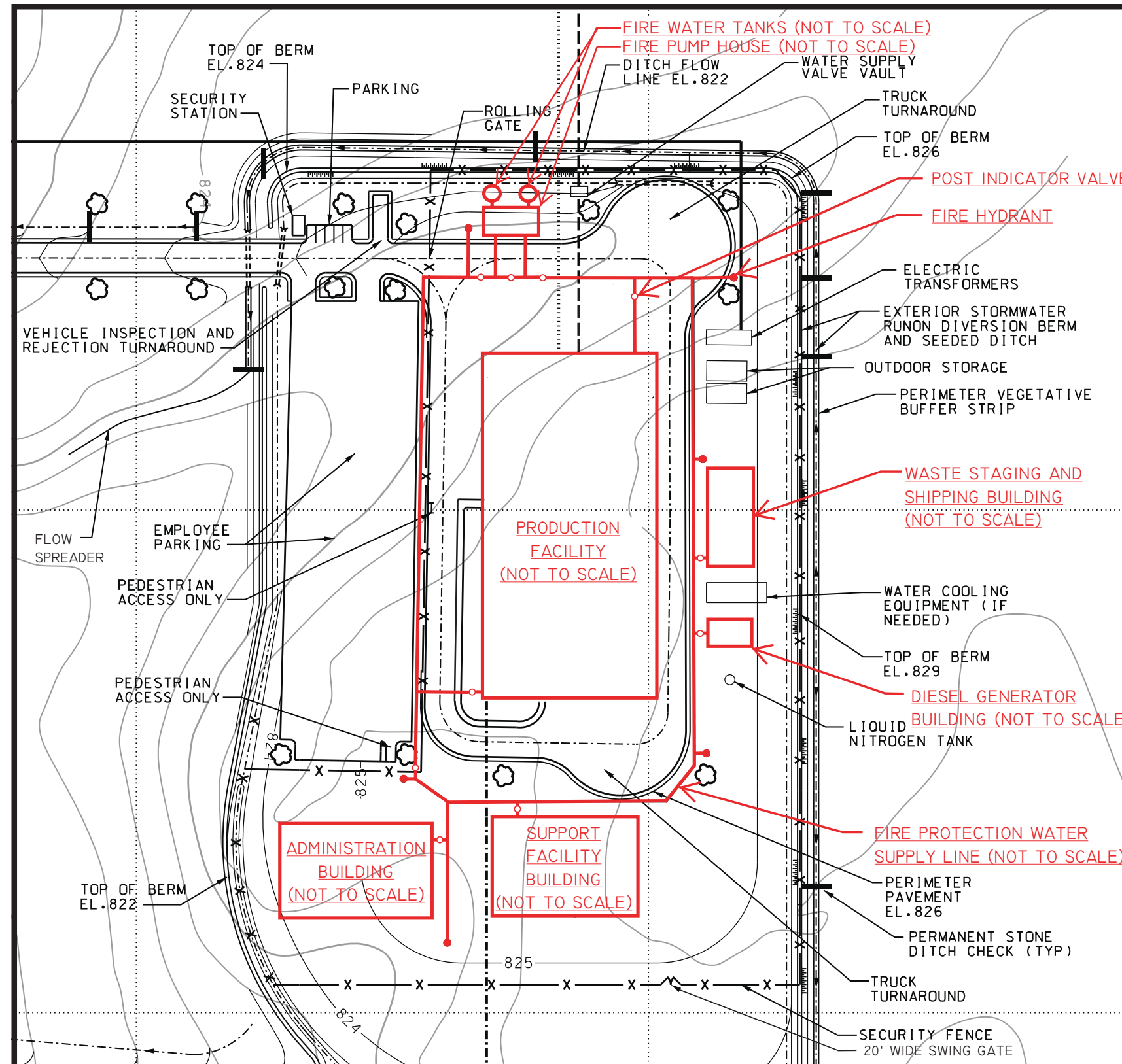

Figure 9a2.3-3 – Fire Protection Process Flow Diagram

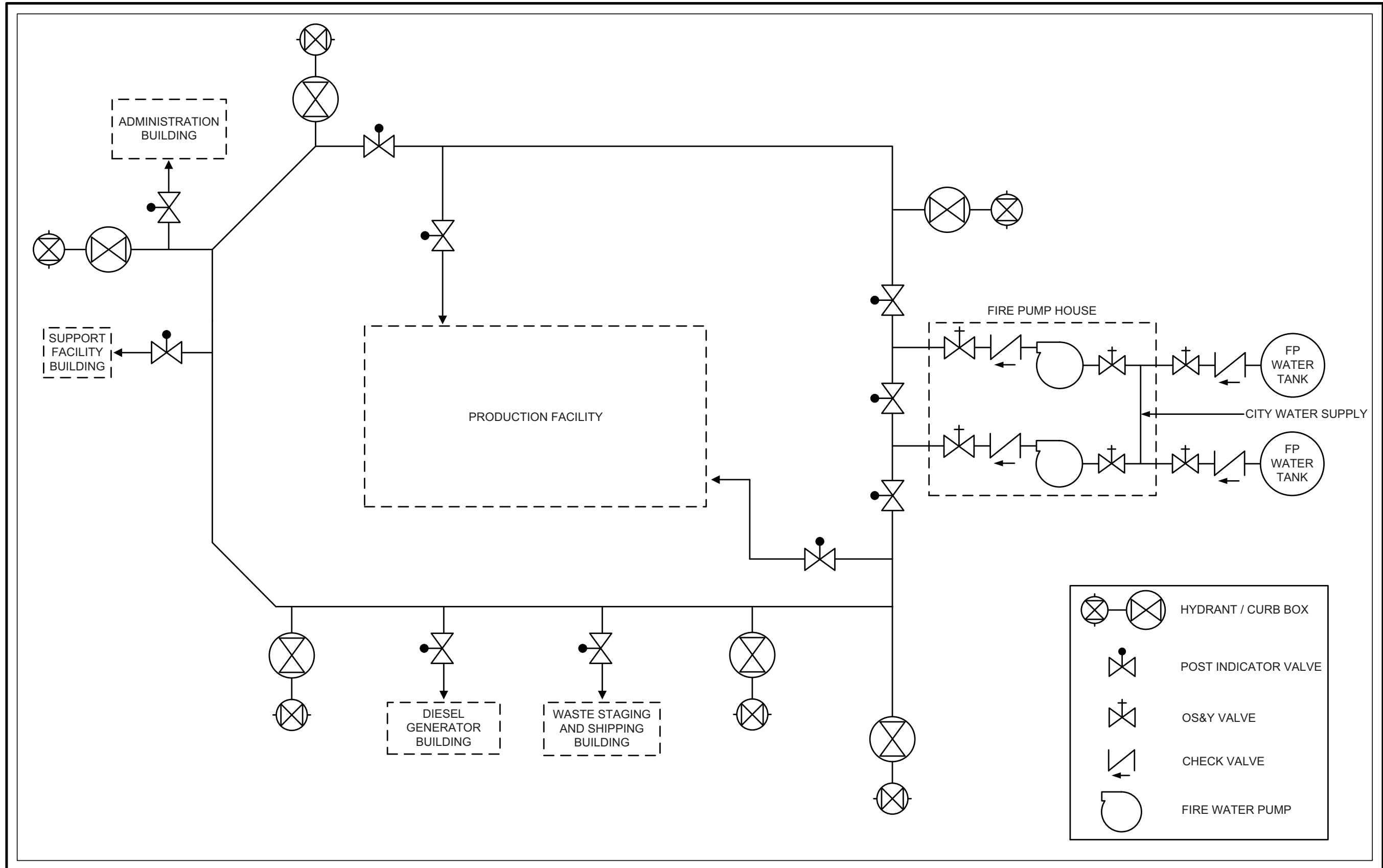
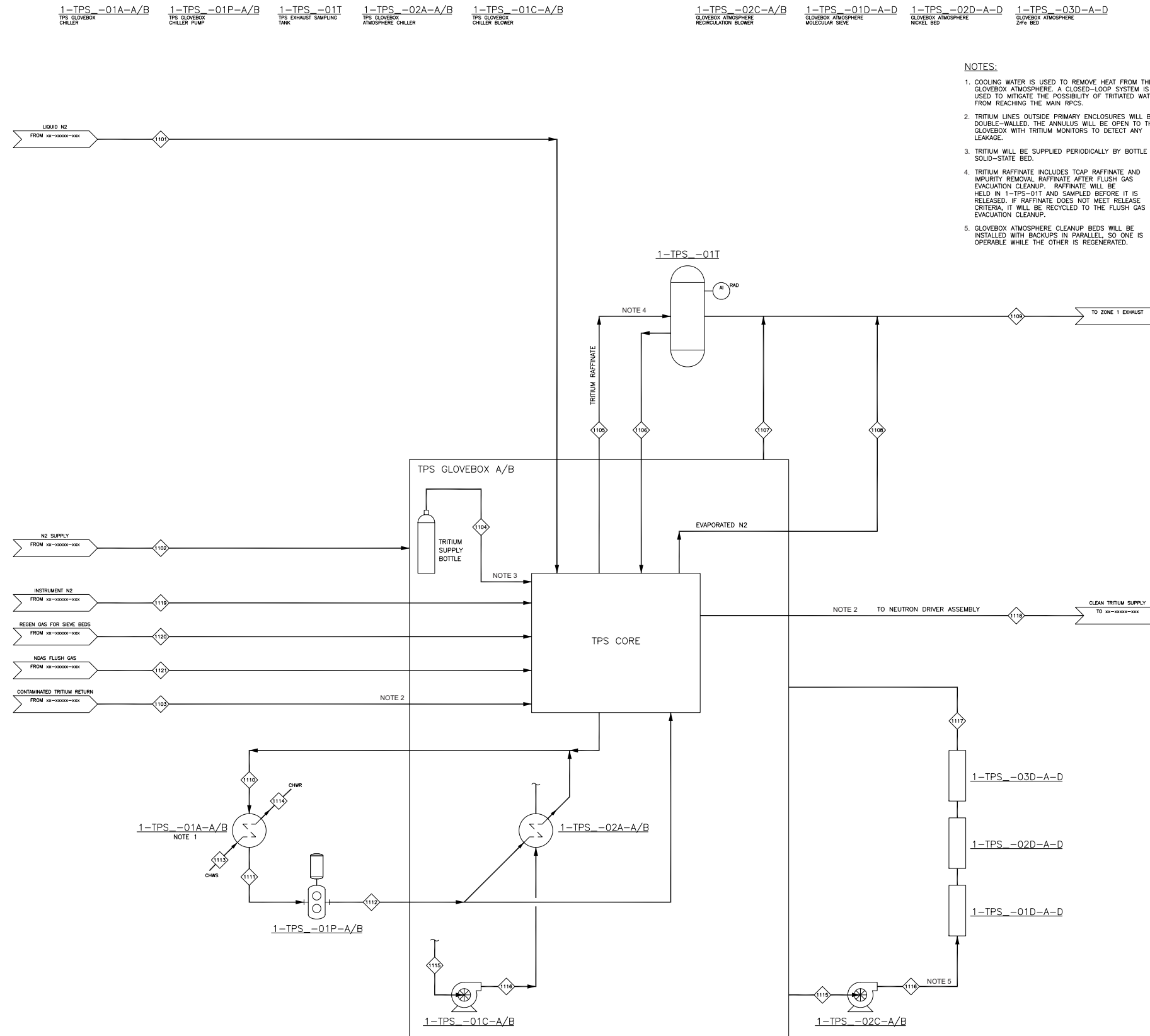

Figure 9a2.7-1 – TPS Process Flow Diagram



DRAWING SCALE
N/S