

APPENDIX C

LOAD CELL CALIBRATION AND ORIGINAL DATA

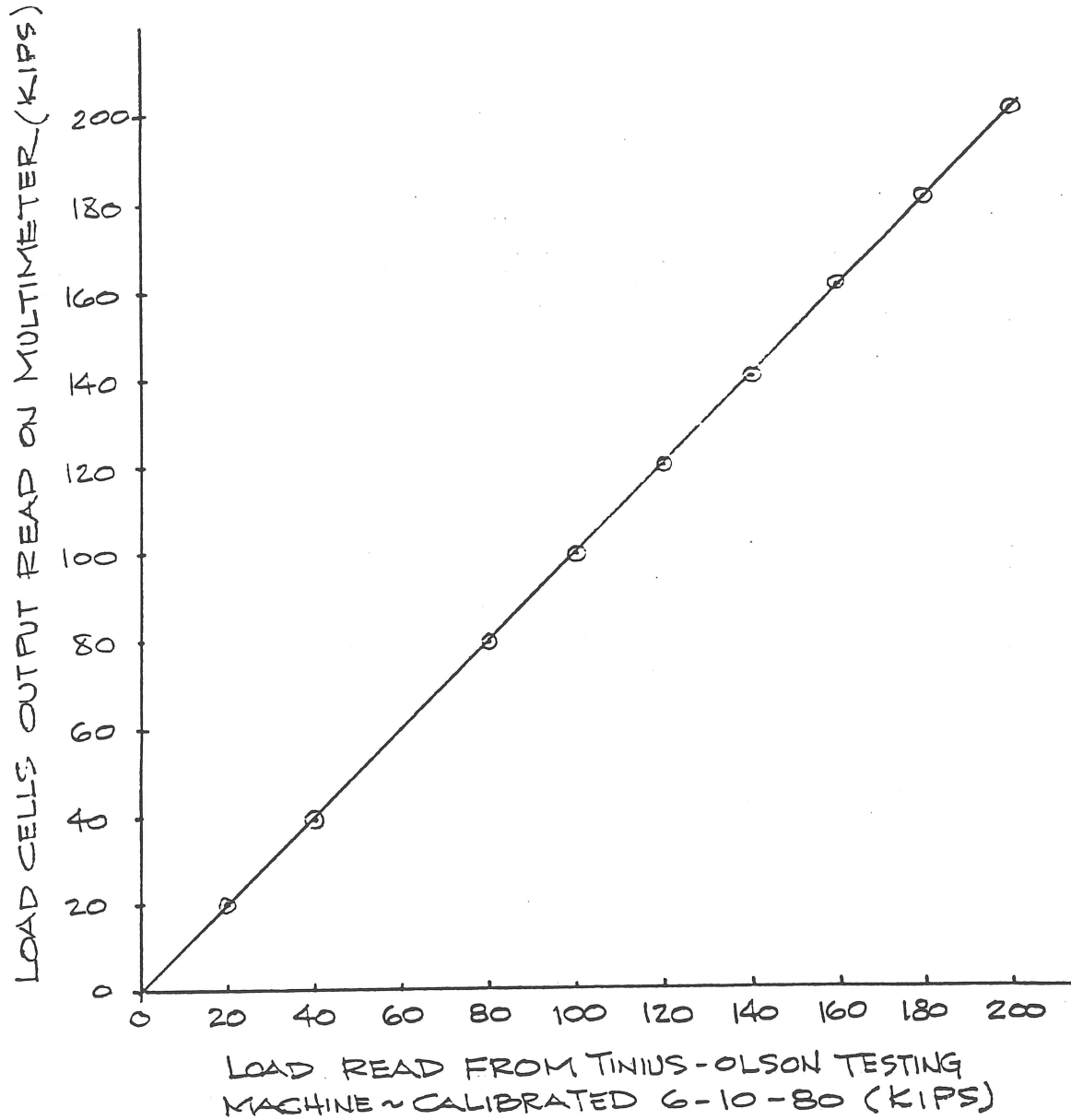

CALIBRATION CURVE FOR LOAD CELLS



UNITED ENGINEERS CONTAINMENT LINER ANCHOR LOAD TEST

1 OF 2

TEST SPECIMEN: SEABROOK T1  
 PEAK LOAD: 152 KIPS  
 f'c: 5,660 PSI (AVG. OF 3)  
 DIAL # 1 LOCATION: ON LINER  
PLATE TO VERIFY HORIZONTAL  
DEFLECTION  
 DIAL # 2 LOCATION: ON CENTER  
OF BACK FACE OF BLOCK TO  
INDICATE BLOCK MOVEMENT  
 VISHAY-ELLIS CALIBRATION #: 290

DATE: 10-16-80  
 WITNESSES: STETHEN, HALEY,  
CODLEY, BURNETTE, LONK,  
GALINK, GRISSETSKIE,  
KALAWADIA

MULTI-METER READING (VOLTS)	LVDT DEFL (IN)	LOAD (KIPS)	DIAL#1 (IN) x10 <sup>3</sup>	DIAL#2 (IN) x10 <sup>3</sup>
0.00	0.000	0.0	0	0
0.31	0.016	84.5	12	6
0.50	0.025	105.3	24	13
0.75	0.038	122.2	39	21
1.00	0.050	137.3	52	27
1.25	0.063	145.3	69	32
1.50	0.075	144.5	80	34
1.75	0.088	78.8	98	32
2.00	0.100	45.9	119	32
SHUT DOWN PUMP TO RESET LVDT				
1.21	0.061	0.0	67	30
1.75	0.085	28.1	98	32
2.00	0.100	36.5	115	32
2.25	0.113	38.7	131	32
2.50	0.125	38.6	146	32
2.75	0.138	38.9	160	32
3.00	0.150	38.7	173	32
3.25	0.163	36.4	189	32
SHUT DOWN PUMP TO RESET LVDT				
1.88	0.094	0.0	107	32
3.25	0.163	29.2	179	32
3.50	0.175	32.2	190	32

COMMENTS:

UNITED ENGINEERS CONTAINMENT LINER ANCHOR LOAD TEST

2 OF 2

TEST SPECIMEN: SEABROOK T1  
 PEAK LOAD: 152 KIPS  
 f'c: PSI  
 DIAL # 1 LOCATION: ON LINER  
PLATE TO VERIFY HORIZONTAL  
DEFLECTION  
 DIAL # 2 LOCATION: ON CENTER  
OF BUNK FACE OF BLOCK  
TO INDICATE BLOCK MOVEMENT  
 VISHAY-ELLIS CALIBRATION #: Z90

DATE: 10-16-80  
 WITNESSES: STEPHEN, HALEY,  
COPLEY, RUDOLPH, LONG,  
GALUNK, KRUSZYSKI,  
KALAWADIA

MULTI-METER READING (VOLTS)	LVDT DEFL (IN)	LOAD (KIPS)	DIAL #1 (IN) x10 <sup>3</sup>	DIAL #2 (IN) x10 <sup>3</sup>
3.75	0.188	35.2	204.	32
4.00	0.200	35.4	222	32
4.25	0.213	35.8	237	32
4.50	0.225	35.1	248	33
4.75	0.238	35.0	263	33
5.00	0.250	35.4	275	33
5.25	0.263	34.2	289	33
SHUT DOWN PUMP TO DISCONNECT LVDT & DIAL #1				
2.73	0.137	0.00	145	33
—	—	28.4	—	33

00 388  
00 392  
00 393  
00 397  
00 400  
00 398  
00 401  
00 386  
00 406  
00 393  
00 403  
00 385  
00 375  
00 345

00 284  
^

DISCONNECT LVDT  
AT HORIZONTAL DEFL. OF  
0.263"

1.80 -----  
00 283  
00 250  
00 213  
00 172  
1.30 00 111  
^

RESET LVDT AT  
HORIZONTAL DEFL. OF 0.10"

00 450  
00 559  
00 752  
00 886  
00 1313  
00 1415  
00 1497.73  
00 1495  
00 1477  
00 1452  
00 1394  
00 1354

00 1325  
00 1296  
00 1253  
00 1165

00 1071  
00 985  
00 892  
00 723  
00 445

BEGIN TEST 00 - 000  
^  
CHANNEL LOAD  
(KIPS)

00 355  
00 352  
00 354  
00 357  
00 355  
00 356  
00 359  
00 357  
00 356  
00 359  
00 360  
00 360  
00 353  
00 355  
00 358  
00 341  
00 341  
00 326  
00 313  
00 300  
00 285  
00 278  
00 262  
00 243  
00 230  
00 26  
00 190  
00 181  
00 167  
00 154  
00 140  
00 126  
00 102  
1.90 00 049  
^

RESET LVDT AT  
HORIZONTAL DEFL. OF 0.163"

TEST 80-26  
SEARPOK T1

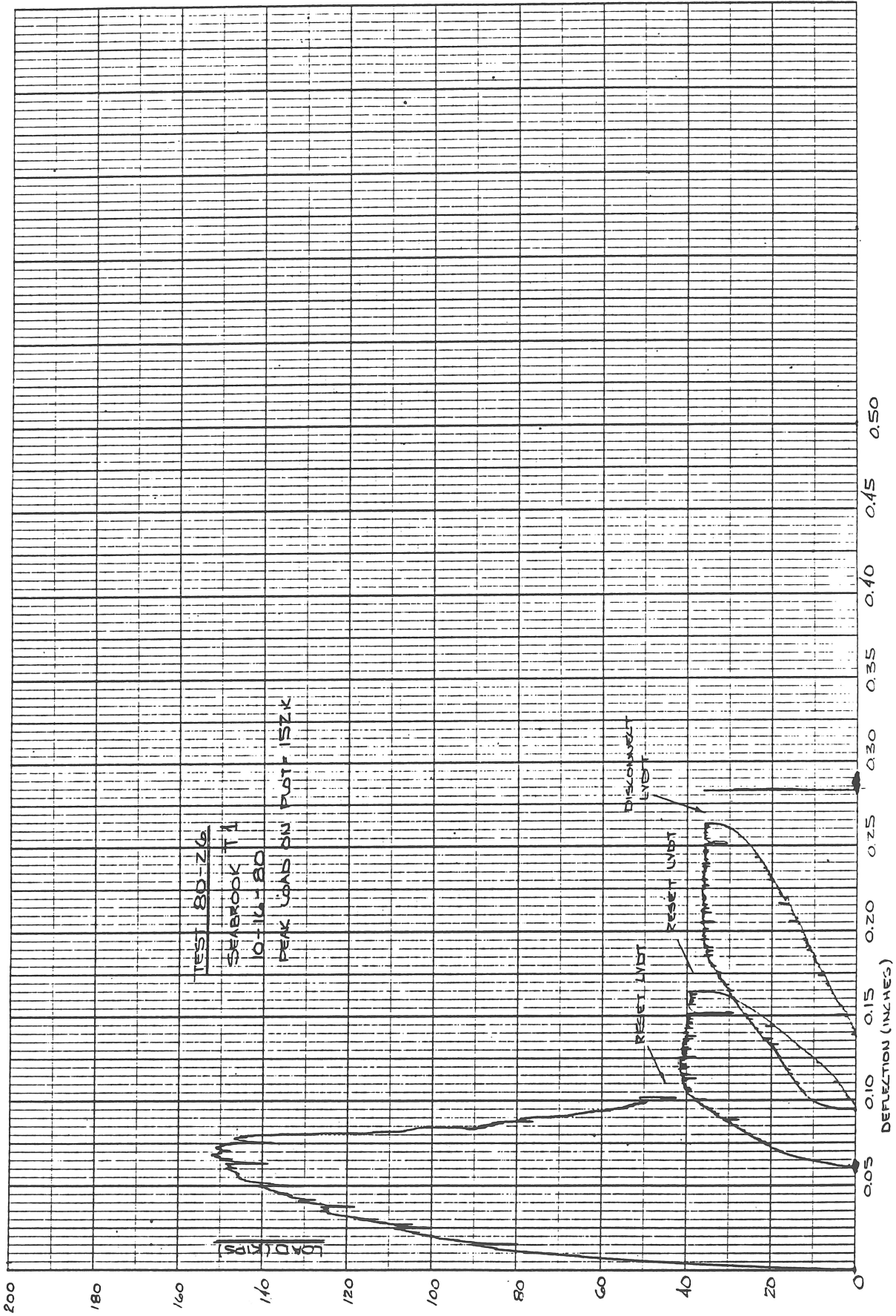

UNITED ENGINEERS CONTAINMENT LINER ANCHOR LOAD TEST

TEST SPECIMEN: SEAROCK T2  
 PEAK LOAD: 156 KIPS  
 f/c: PSI  
 DIAL # 1 LOCATION: SLIGHTLY  
ABOVE LVDT PROBE TO  
VERIFY HORIZONTAL DEFLECTION  
 DIAL # 2 LOCATION: 7" FROM  
BACK FACE MOUNTED ON SIDE  
FACE TO INDICATE ROTATION  
 VISHAY-ELLIS CALIBRATION #: 290

DATE: 10-20-80 1 OF 1  
 WITNESSES: STATHEN, HALEY,  
HAYES, COOLEY, BURDETTE,  
AND HOLBROOK

TEST 80-26

MULTI-METER READING (VOLTS)	LVDT DEFL (IN)	LOAD (KIPS)	DIAL#1 (IN) x10 <sup>3</sup>	DIAL#2 (IN) x10 <sup>3</sup>
0.00	0.000	0.0	0	0
0.25	0.013	7.48	13	3
0.50	0.025	118.0	26	9
0.75	0.038	137.1	39	13
1.00	0.050	148.0	52	19
1.25	0.063	153.7	66	25
1.50	0.075	62.9	80	5
1.75	0.088	39.9	97	5
2.00	0.100	37.7	113	4
2.50	0.125	36.9	145	4
3.00	0.150	34.8	175	4
3.50	0.175	34.1	203	4
4.00	0.200	34.3	231	4
4.50	0.225	34.1	259	4
5.00	0.250	34.0	288	4
6.00	0.300	28.2	344	4
7.00	0.350	18.9	403	4
8.00	0.400	20.2	458	4
9.00	0.450	20.6	515	4
9.96	0.498	19.7	569	4
6.18	0.309	0.0	369	2

COMMENTS:

PUMP SHUT DOWN TO DISCONNECT LVDT AND DIAL#1

SB 1 & 2  
FSAR

Amendment 52  
December 1983

DEPL. (INCH)	CHANNEL	LOAD (KIPS)		
00		341	0.50	00 202
00		345		00 212
00		346		00 212
00		337		00 213
00		345		00 204
0.20		343		00 210
00		334		00 209
00		343		00 211
00		345		00 210
00		348		00 213
00		341	0.45	00 206
00		352		00 209
00		350		00 211
00		349		00 218
00		351		00 209
0.15		348		00 214
00		359		00 203
00		360		00 210
00		358		00 209
00		355		00 210
00		369	0.40	00 202
00		365		00 206
00		369		00 203
00		375		00 202
00		352		00 199
0.10		378		00 199
00		378		00 196
00		398		00 195
00		435		00 192
00		517		00 189
00		629	0.35	00 189
00		1529		00 187
00		1520		00 188
00		2154.2		00 186
00		1511		00 191
0.05		1475		00 210
00		1443		00 213
00		1377		00 247
00		1339		00 263
00		1252		00 277
00		1180	0.30	00 282
00		1050		00 288
00		896		00 296
00		683		00 296
00		376		00 297
0.00		000		00 302
				00 301
				00 304
				00 315
				00 337
				00 340
				00 344
				00 347

END TEST

	00	033
	00	006
	00	194
	00	217
INTERMITTENT	00	191
LOAD READING	00	181
	00	170
	00	161
	00	155
	00	119
	00	053

DISCONNECT LVDT  
DIAL #1

EST 80-Z6  
SEABROOK TZ  
PEAK LOAD ON PLOT=156K 0.25  
PEAK LOAD ON TAPE=154.2K  
10-20-80

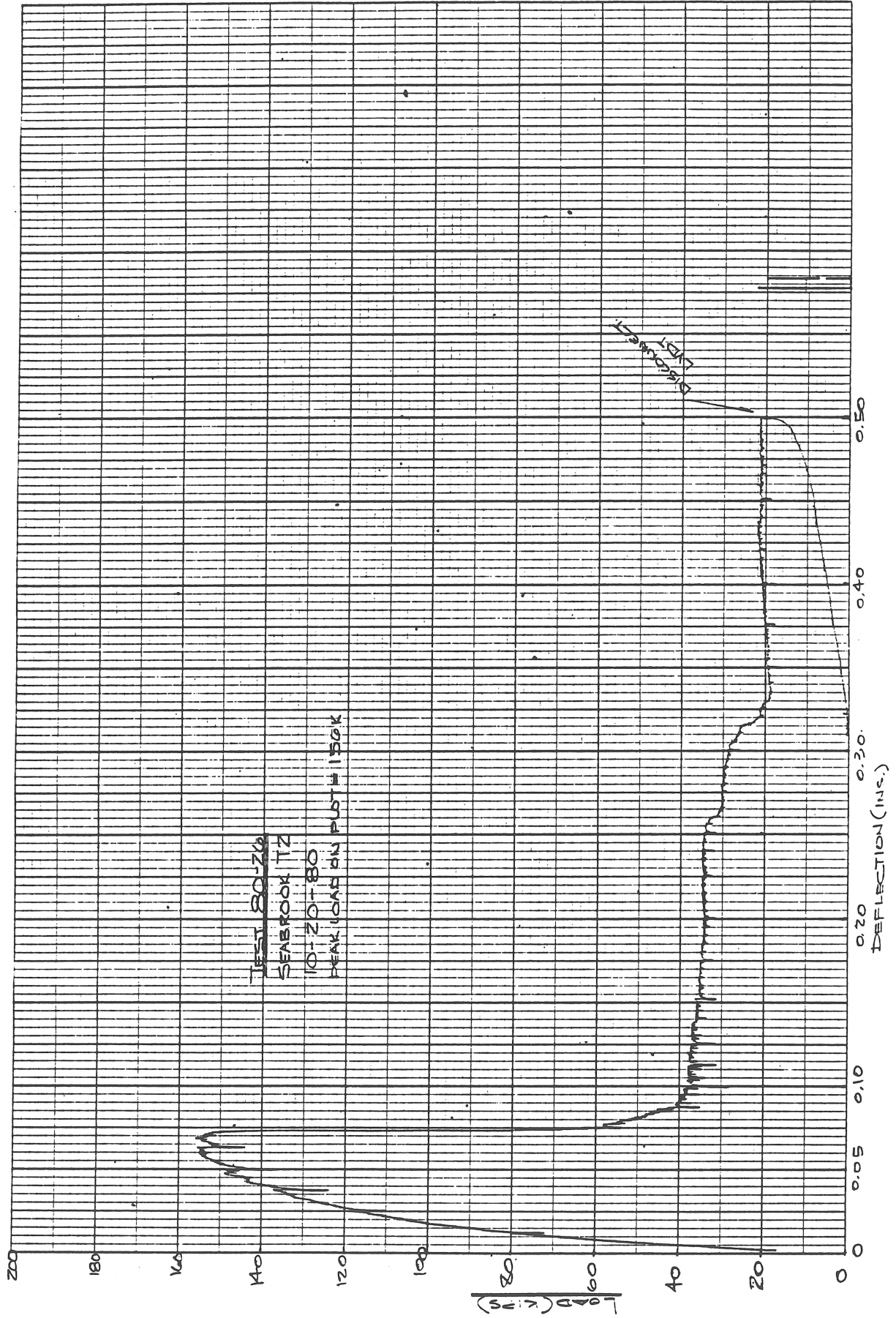



UNITED ENGINEERS CONTAINMENT LINER ANCHOR LOAD TEST

TEST SPECIMEN: SEABROOK T3  
 PEAK LOAD: 144 KIPS  
 f'c: PSI  
 DIAL # 1 LOCATION: 1.5 IN.  
ABOVE LVDT PROBE TO VERIFY  
HORIZONTAL DEFL 14" FROM T  
 DIAL # 2 LOCATION: 7" FROM  
BACK FACE MOUNTED ON SIDE  
FACE TO INDICATE ROTATION  
 VISHAY-ELLIS CALIBRATION #: 290

DATE: 10-24-80  
 WITNESSES: STEPHEN, HAYES  
HAYES, COBLEY, HOLBROOK,  
& BURDETTE  
 DIAL # 3 LOCATION: 6 IN BEHIND  
T TO MEASURE PLATE  
LIFT-UP

TEST 80-26

MULTI-METER READING (VOLTS)	LVDT DEFL (IN)	LOAD (KIPS)	DIAL #1 (IN) $\times 10^3$	DIAL #2 (IN) $\times 10^3$	DIAL #3 (IN) $\times 10^3$
0.00	0.000	0.0	0	0	0
0.25	0.013	76.6	13	0	16
0.50	0.025	106.9	27	1	39
0.75	0.038	128.3	40	2	69
1.00	0.050	141.3	53	3	102
1.25	0.063	85.3	65	1	210 @ PEAK 290 ABRUPT 310 @ 1.25
1.50	0.075	67.0	82	0	297
1.75	0.088	35.0	92	0	428
2.00	0.100	39.7	105	0	505
2.50	0.125	39.4	133	0	629
3.00	0.150	39.0	160	0	745
3.50	0.175	38.6	186	0	855
4.00	0.200	38.2	213	0	DISCONNECT
5.00	0.250	31.6	268	2	---
6.00	0.300	32.1	322	2	---
7.00	0.350	26.0	375	0	---
8.00	0.400	25.8	429	0	---
9.00	0.450	25.5	482	0	---
9.96	0.500	22.8	534	0	---
6.37	0.319	0.0	365	0	---

SURDETTE  
 OCC ON  
 LATE

COMMENTS:



00	354
00	357
00	365
00	375
DISCONNECT	00 381
DIAL# 3	00 382
0.20	00 385
00	387
00	387
00	388
00	386
00	386
00	389
00	391
00	387
0.15	00 390
00	394
00	396
00	397
00	396
00	394
00	392
00	387
00	391
00	397
0.101	00 392
0.10	00 397
00	389
00	370
00	326
00	257
00	090
00	751
00	822
00	1404
00	1438
0.05	00 1413
00	1372
00	130
00	1257
00	1177
00	1069
00	973
00	839
00	692
00	460
0.00	00 - 000

0.50	UU	222
00	00	250
00	00	252
00	00	252
00	00	252
00	00	253
00	00	252
00	00	255
00	00	256
00	00	254
0.45	00	255
00	00	258
00	00	261
00	00	262
00	00	262
00	00	262
00	00	256
00	00	258
00	00	257
00	00	260
0.40	00	258
00	00	263
00	00	265
00	00	269
00	00	275
00	00	272
00	00	271
00	00	270
00	00	266
00	00	272
0.35	00	260
00	00	262
00	00	262
00	00	265
00	00	270
00	00	278
00	00	278
00	00	282
00	00	286
00	00	290
0.30	00	321
00	00	331
00	00	332
00	00	333
00	00	337
00	00	335
00	00	336
00	00	337
00	00	332
00	00	330
0.25	00	316
00	00	321
00	00	324
00	00	310

23.3

END TEST

INTERMITTENT  
LOAD  
READINGS

00	000
00	007
00	046
00	043
00	016
00	005
00	128
00	092
00	142
00	136
00	127
00	181
00	166
00	172
00	158
00	138
00	112
00	074
00	249
00	252
00	238
00	241
00	235
00	194
00	140
00	100
00	065
00	042
00	023
00	009

DISCONNECT LVNT

TEST 80-26  
SEABROOK T 3  
PEAK LOAD ON PLOT = 143K  
PEAK LOAD ON TAPE = 143.8

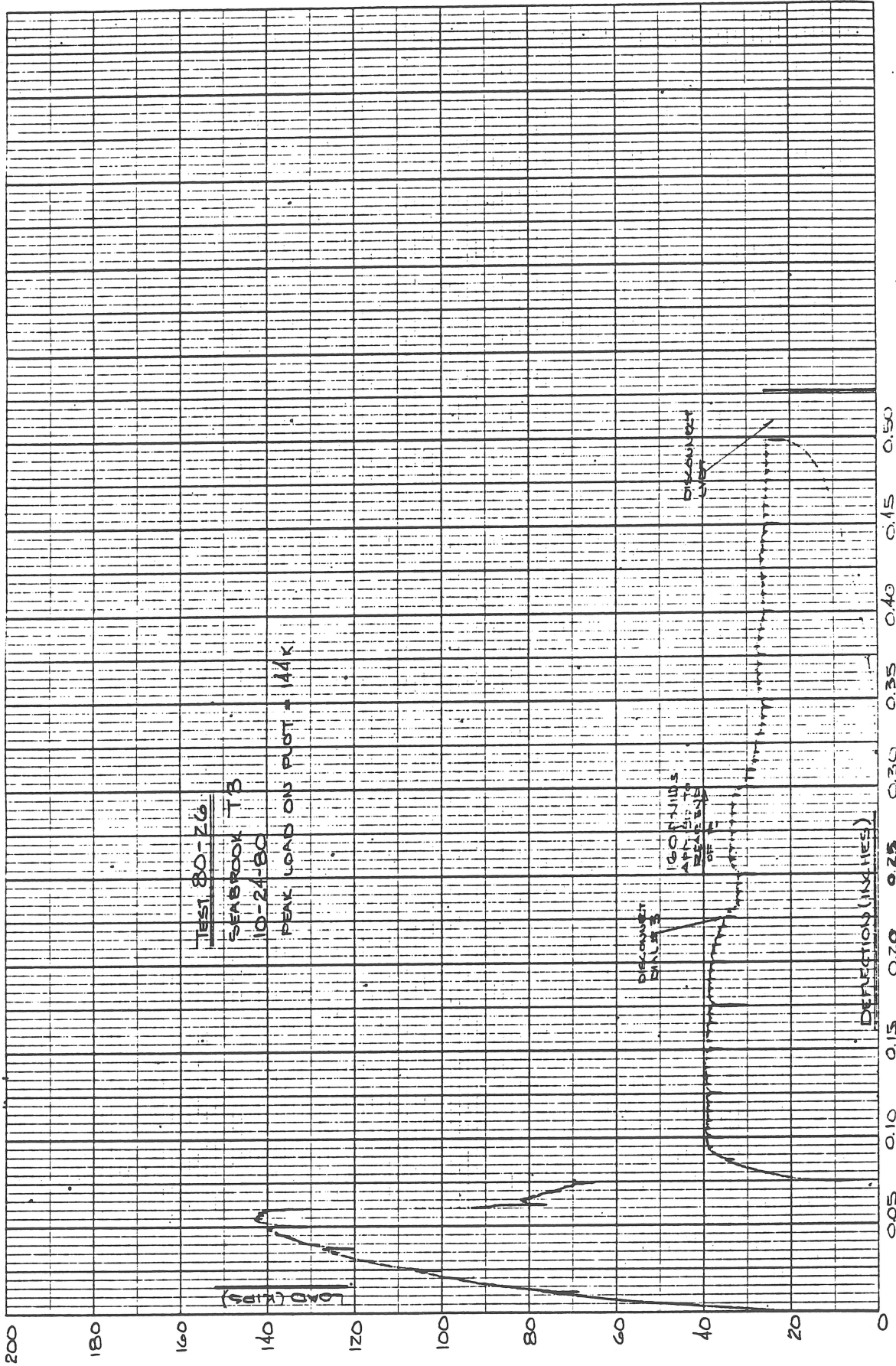

UNITED ENGINEERS CONTAINMENT LINER ANCHOR LOAD TEST

TEST SPECIMEN: STUDS 1  
 PEAK LOAD: 51 KIPS  
 f'c: PSI  
 DIAL # 1 LOCATION: 1.5 IN  
ABOVE LVDT PROBE TO VERIFY  
HORIZONTAL DEFL. 1" FROM STUDS  
 DIAL # 2 LOCATION: 7" FROM  
BACK FACE MOUNTED ON  
SIDE FACE TO INDICATE ROTATION  
 VISHAY-ELLIS CALIBRATION #: Z90

DATE: 11-7-80 1 OF 1  
 WITNESSES: STETHEN, HOLZBROCK,  
CANNON, BURDETTE, FUNK,  
PERRY  
 DIAL # 3 LOCATION: 5 IN  
BEHIND STUDS TO MEASURE  
PLATE

TEST 80-26

MULTI-METER READING (VOLTS)	LVDT DEFL (IN)	LOAD (KIPS)	DIAL#1 (IN) x10 <sup>3</sup>	DIAL#2 (IN) x10 <sup>3</sup>	DIAL#3 (IN) x10 <sup>3</sup>
0.00	0.000	0.0	0	—	0
0.25	0.013	15.5	12	—	8
0.50	0.025	28.7	24	—	18
0.75	0.038	36.3	37	—	28
1.00	0.050	39.4	50	—	36
1.25	0.063	41.2	63	—	43
1.50	0.075	42.4	76	—	49
1.75	0.088	43.0	90	—	53
2.00	0.100	43.7	104	—	58
2.50	0.125	44.0	129	—	65
3.00	0.150	44.9	155	—	72
4.00	0.200	46.3	207	—	84
5.00	0.250	46.9	258	—	92
6.00	0.300	49.1	310	—	100
7.00	0.350	50.0	362	—	103
8.00	0.400	0.0	FAILURE OF 1 STUD ONLY (RIGHT STUD)		
9.00	0.450	26.2	—	—	—
9.95	0.500	24.0	—	—	—
9.59	0.480	0.0	—	—	—
1/2" MAXIMUM TRAVEL REACHED, LOAD REMAINING STUD TO FAILURE (SEE D.O.T)					

SB 1 & 2  
FSAR

Amendment 52  
December 1983

00	465	
00	469	
00	469	
00	468	
0.20	463	
00	465	
00	467	
00	460	
00	460	
00	456	
00	446	
00	451	
00	449	
00	453	
0.15	449	
00	453	
00	447	
00	447	
00	446	
00	440	
00	442	
00	436	
00	441	
00	434	
0.10	437	
00	435	
00	428	
00	430	
00	429	
00	424	
00	420	
00	416	
00	408	
00	400	
0.05	388	
00	383	
00	368	
00	362	
00	318	
00	287	
00	196	
00	161	
00	143	
00	101	
0.0	000	
<u>DEF</u>	<u>CHANNEL</u>	<u>LOAD</u>
(IN)		(KIPS)

00	262
00	264
0.45	260
00	262
00	260
00	256
00	255
00	251
00	230
00	193
00	161
00	108
0.40	052

RIGHT STUD FAILED  
CONTINUE LOADING

00	486
00	504
00	504
00	506
00	503
00	509
00	507
00	502
0.35	500
00	504
00	500
00	503
00	498
00	496
00	493
00	492
00	487
00	494
0.30	491
00	485
00	489
00	489
00	485
00	484
00	485
00	483
00	485
00	483
0.25	469
00	477
00	475
00	474

MAXIMUM TRAVEL OFF  
1/2"

00	240
00	265
00	262
00	262
00	259
00	266
00	263

TEST 80-26

STUDS 1

PEAK LOAD ON PLOT = 51.5K

PEAK LOAD ON TAPE = 50.9K

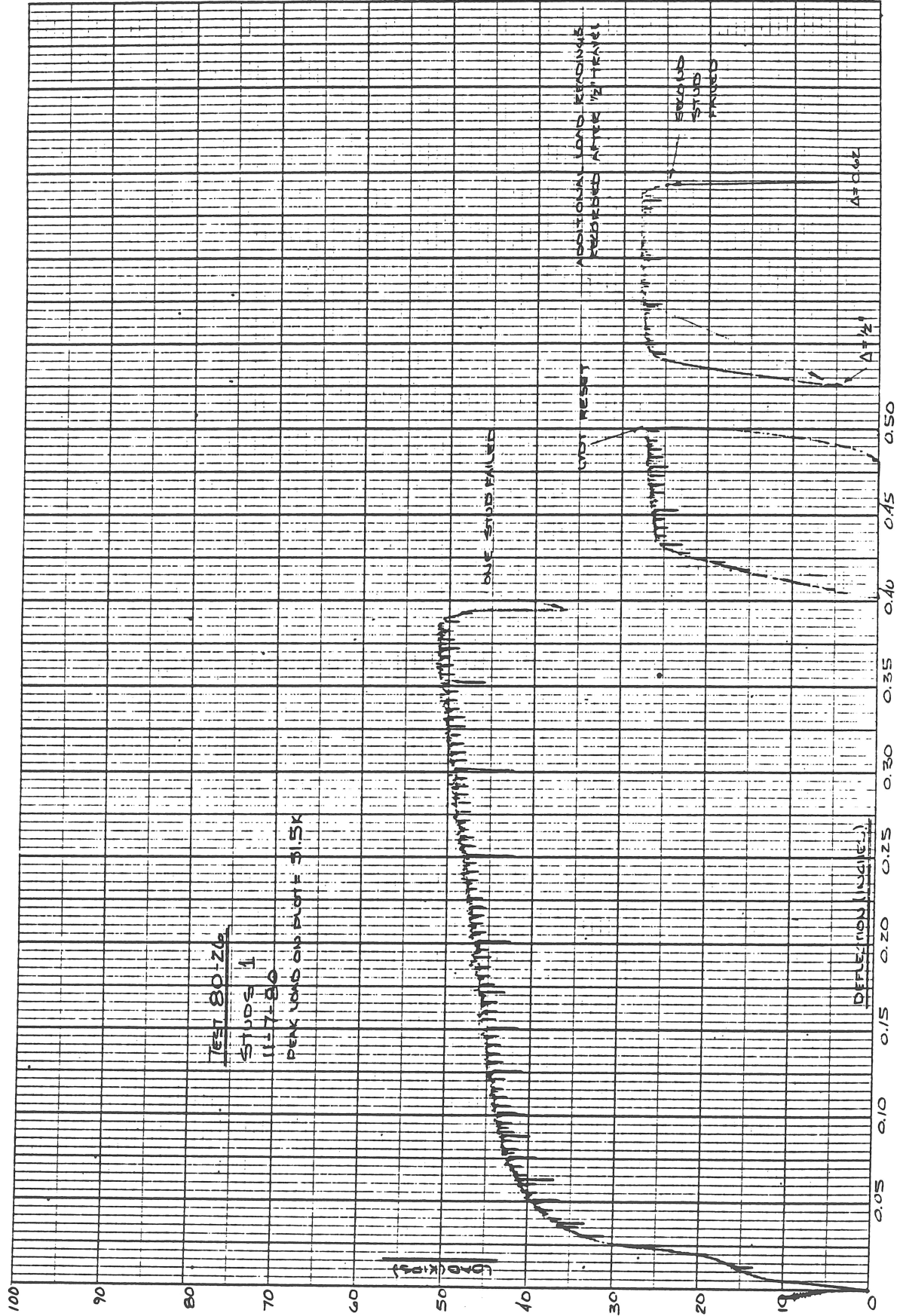

UNITED ENGINEERS CONTAINMENT LINER ANCHOR LOAD TEST

1 of 1

TEST SPECIMEN: STUDS 2  
 PEAK LOAD: 54.8 KIPS  
 f'c: PSI  
 DIAL # 1 LOCATION: 1.5 IN  
ABOVE LVDT PROBE TO VERIFY  
HORIZONTAL DEF. 14 IN FROM STUDS  
 DIAL # 2 LOCATION: 7 IN FROM  
BACK FACE MOUNTED ON SIDE  
FACE TO INDICATE ROTATION  
 VISHAY-ELLIS CALIBRATION #: 290

DATE: 11-21-80  
 WITNESSES: STEPHEN, BURETT,  
P. HAYES, T. HAYES, FUNK, PERRY,  
COBLEY  
DIAL #3 LOCATION: 3 IN BEHIND  
STUDS TO MEASURE PLATE  
UPLIFT

TEST 80-26

MULTI-METER READING (VOLTS)	LVDT DEFL (IN)	LOAD (KIPS)	DIAL#1 (IN) x10 <sup>3</sup>	DIAL#2 (IN) x10 <sup>3</sup>	DIAL#3 (IN) x10 <sup>3</sup>
0.00	0.000	0.0	0	0	0
0.25	0.013	24.2	12	0	9
0.50	0.025	29.8	24	0	17
0.75	0.038	34.6	37	0	25
1.00	0.050	37.9	50	0	32
1.25	0.063	38.3	64	0	39
2.00	0.100	41.6	103	0	52
3.00	0.150	42.8	155	0	65
4.00	0.200	44.0	208	0	77
5.00	0.250	44.2	260	0	83
6.00	0.300	46.4	312	0	88
7.00	0.350	47.6	364	0	92
8.00	0.400	49.7	416	0	95
9.00	0.450	49.7	468	0	96
9.96	0.500	48.8	518	0	99
9.14	0.457	0.0	—	—	—
RESET LVDT, CONTINUE TEST (SEE PLOT)					

	00	507	00	446	
	00	507	00	449	
	00	508	00	433	
	00	502	00	446	
	00	505	<u>0.20</u>	<u>00</u>	440
	00	502		00	441
<u>0.45</u>	<u>00</u>	<u>497</u>		00	435
	00	483		00	442
	00	493		00	438
	00	490		00	435
	00	493		00	439
	00	494		00	438
	00	497		00	434
	00	490		00	432
	00	494	<u>0.15</u>	<u>00</u>	<u>428</u>
	00	492		00	434
<u>0.40</u>	<u>00</u>	<u>481</u>		00	429
	00	490		00	431
	00	488		00	428
	00	485		00	425
	00	484		00	426
	00	481		00	428
	00	473		00	419
	00	481		00	417
	00	480	<u>0.10</u>	<u>00</u>	<u>416</u>
	00	476		00	415
<u>0.35</u>	<u>00</u>	<u>476</u>		00	415
	00	477		00	407
	00	474		00	405
	00	471		00	401
	00	470		00	401
	00	473		00	397
	00	467		00	386
	00	467		00	383
	00	484	<u>0.05</u>	<u>00</u>	<u>379</u>
	00	457		00	373
<u>0.30</u>	<u>00</u>	<u>464</u>		00	359
	00	459		00	347
	00	463		00	323
	00	461		00	298
	00	450		00	301
	00	456		00	286
	00	459		00	240
	00	454		00	155
	00	458	<u>0.00</u>	<u>00</u>	<u>-</u>
	00	453	<u>DEFL</u>	<u>CHANNEL</u>	<u>LOAD</u>
<u>0.25</u>	<u>00</u>	<u>43</u>	<u>(IN)</u>		<u>(KIP)</u>
	00	450			
	00	452			
	00	451			
	00	450			
	00	448			

TEST 80-26

PEAK LOAD ON PLOT = 54.8K

PEAK LOAD ON TAPE = 54.2K

11-21-80

00 033  
00 - 001

ONE STUD FAILED,  
DISCONNECT PLOTTER & TAKE  
RANDOM LOAD READINGS  
OF FINAL STUD

0.68	00	468
	00	496
	00	507
	00	511
	00	520
	00	521
0.65	00	528
	00	519
	00	531
	00	529
	00	538
	00	531
	00	542
	00	539
	00	540
	00	532
0.60	00	539
	00	534
	00	540
	00	535
	00	535
	00	533
	00	536
	00	531
	00	535
	00	526
0.55	00	515
	00	512
	00	524
	00	519
	00	519
	00	518
	00	518
	00	514
	00	502
	00	500
0.50	00	424

SECOND STUD FAILED,  
END TEST

00	-	002
00		280
00		275
00		284
00		287
00		288
00		283
00		286
00		286
00		287
00		286
00		282
00		282
00		279
00		279
00		276
00		268
00		239
00		204
00		164
00		116
00		070

RESET LVDT & CONTINUE  
LOADING

0.50	00	488
	00	509
	00	514
	00	512



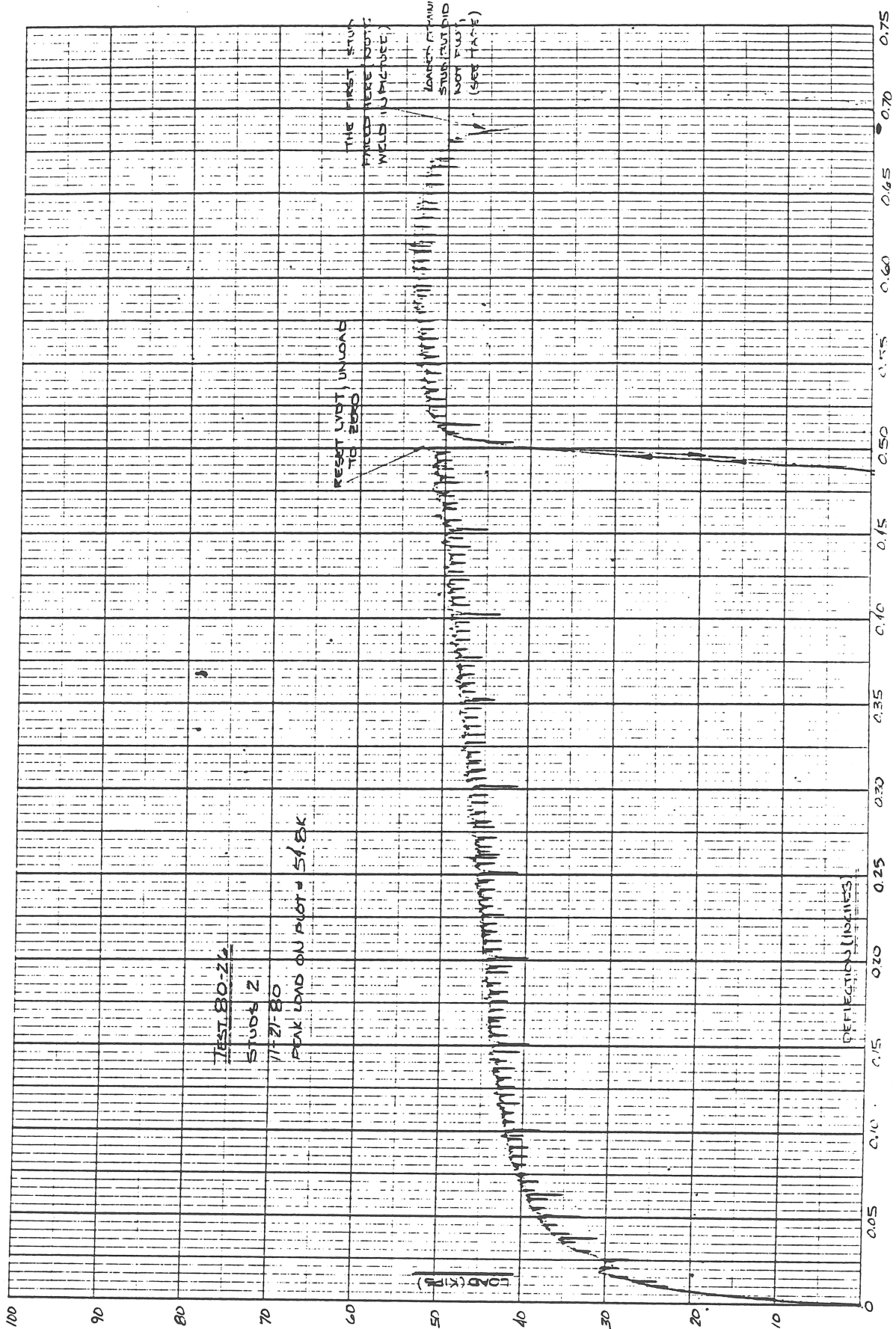

UNITED ENGINEERS CONTAINMENT LINER ANCHOR LOAD TEST

1 OF 1

TEST SPECIMEN: STUDS 3  
 PEAK LOAD: 52.5 KIPS  
 f'c: PSI  
 DIAL # 1 LOCATION: 1.5 IN ABOVE  
LVDT PROBE TO INDICATE HORIZONTAL  
DEFLECTION OF PLATE  
 DIAL # 2 LOCATION: 7 IN FROM  
THE BACK FACE OF BLOCK TO  
INDICATE ROTATION  
 VISHAY-ELLIS CALIBRATION #: 290

DATE: 12-2-80  
 WITNESSES: STEPHEN, HALEY,  
CORREY, BURDETTE, T. HAYES,  
CAWNER  
DIAL # 3 LOCATION: 3 1/2 IN BEHIND  
STUDS TO MEASURE PLATE  
UPLIFT

TEST 80-26

MULTI-METER READING (VOLTS)	LVDT DEFL (IN)	LOAD (KIPS)	DIAL #1 (IN) x10 <sup>3</sup>	DIAL #2 (IN) x10 <sup>3</sup>	DIAL #3 (IN) x10 <sup>3</sup>
0.00	0.000	0.0	0	0	0
0.25	0.013	15.7	12	0	5
0.50	0.025	29.9	24	0	17
0.75	0.038	37.9	36	0	27
1.00	0.050	39.7	50	0	38
1.25	0.063	40.6	62	0	46
1.50	0.075	42.7	76	0	52
2.00	0.100	43.8	102	0	61
3.00	0.150	45.9	154	0	77
4.00	0.200	47.1	207	0	93
5.00	0.250	48.4	258	0	104
6.00	0.300	49.6	311	0	115
7.00	0.350	50.0	361	0	125
8.00	0.400	50.9	415	0	130
9.00	0.450	50.3	466	0	135
ONE STUD FAILED, RESET LVDT, DISCONNECT DIAL # 1					
6.30	0.550	24.1	————	2	132
7.30	0.600	SECOND STUD FAILED			
*NOTE: BOTH STUDS FAILED OUTSIDE THE WELD REGION					

SB 1 & 2  
FSAR

Amendment 52  
December 1983

	00	504
	00	513
	00	505
	00	507
	00	511
	00	510
	00	512
0.45	00	503
	00	498
	00	508
	00	507
	00	508
	00	406
	00	506
	00	506
	00	510
0.40	00	512
	00	509
	00	508
	00	516
	00	515
	00	513
	00	513
	00	511
	00	510
	00	505
	00	514
0.35	00	500
	00	502
	00	507
	00	505
	00	502
	00	505
	00	503
	00	500
	00	487
	00	501
0.30	00	496
	00	497
	00	492
	00	494
	00	495
	00	497
	00	489
	00	487
	00	488
	00	487
0.25	00	484
	00	483
	00	480
	00	473
	00	480
	00	476

	00	478
	00	473
	00	473
	00	470
0.20	00	471
	00	468
	00	471
	00	468
	00	468
	00	464
	00	463
	00	462
	00	459
	00	462
0.15	00	459
	00	453
	00	448
	00	449
	00	452
	00	449
	00	448
	00	447
	00	436
	00	444
0.10	00	438
	00	439
	00	436
	00	435
	00	432
	00	427
	00	427
	00	418
	00	413
	00	411
0.05	00	397
	00	390
	00	380
	00	365
	00	334
	00	299
	00	267
	00	214
	00	129
	00	088
0.0	00	000

<u>DEFL.</u>	<u>CHANNEL</u>	<u>LOAD</u>
(IN)		(KIPS)

TEST 80-26

PEAK LOAD ON PLOT = 52.5K

PEAK LOAD ON TAPE = 51.6K

STUDS 3

17-7-87

SECOND STUD FAILED,  
END TEST

<u>0.585</u>	<u>00</u>	<u>214</u>
	00	237
	00	244
	00	245
	00	245
	00	246
	00	245
<u>0.55</u>	<u>00</u>	<u>241</u>
	00	241
	00	243
	00	241
	00	238
	00	219
	00	191
	00	157
	00	109
	00	067
<u>0.50</u>	<u>00</u>	<u>025</u>

ONE STUD FAILED,  
RESET LVDT, REMOVE  
DIAL # 1

0.495	00 -	000
	00	487

3G-51

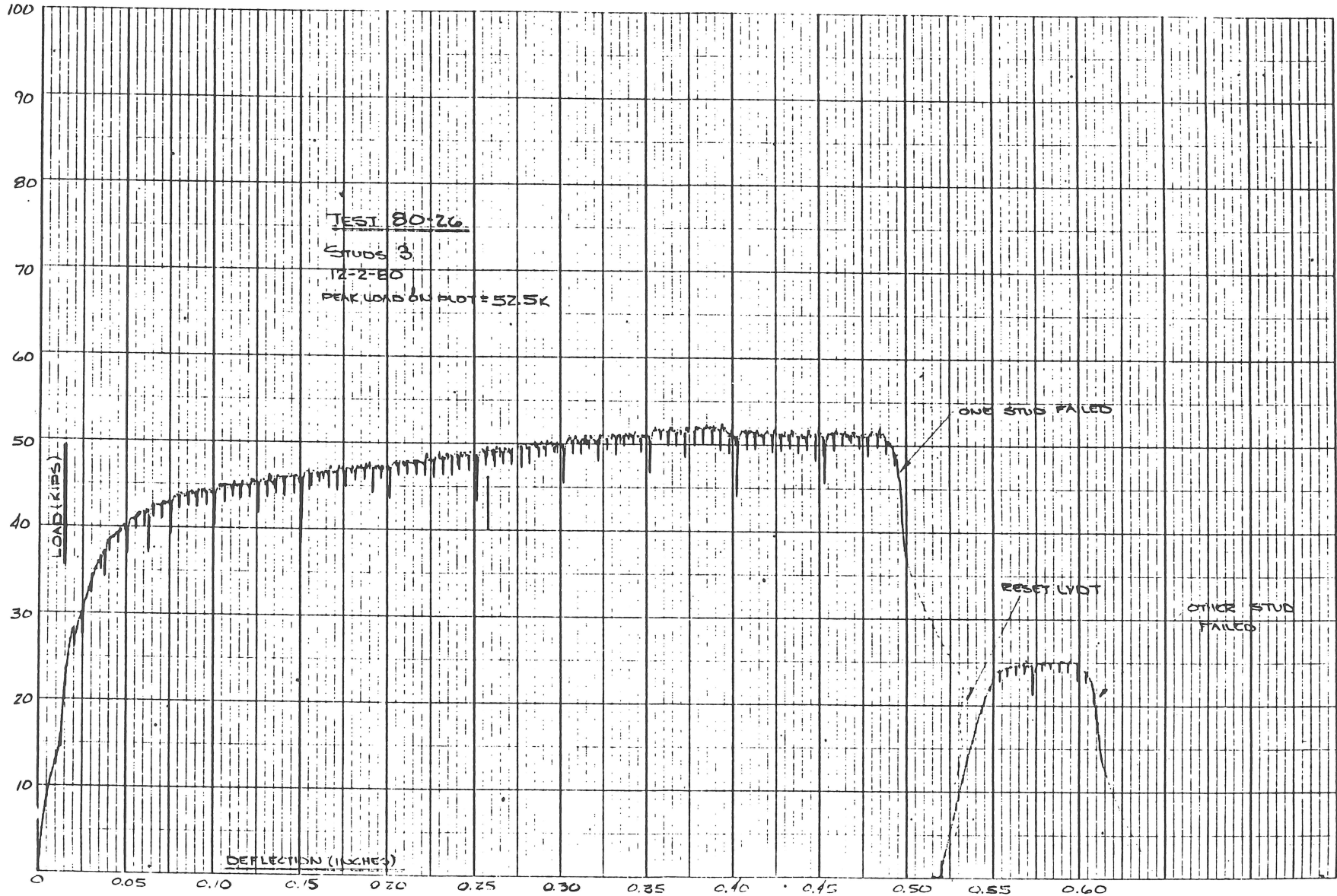

CONTAINMENT LINER ANCHOR LOAD TEST  
FABRICATION OF SPECIMENS  
SEABROOK PROJECT

Date: April 7, 1981

Prepared by: Branke Galunic  
B. Galunic

Containment Liner Anchor Load Test  
Fabrication of Specimens  
Seabrook Project

1. INTRODUCTION

The containment structure at the Seabrook Nuclear Project is a right vertical cylinder having an inside radius of 140 feet and wall thickness of 4'-6", and it has a hemispherical dome which is 3'-6" thick. At the base is a 10 foot thick mat. It is designed to resist the pressure from the most severe break in a reactor coolant pipe. In order to meet the leak tightness requirements of the vessel, a steel liner plate is installed over the inside surface of the concrete. The liner is generally 3/8 inch thick in the cylindrical portion and is thickened to 3/4 inches in the penetration areas near the base. The liner in the dome has a uniform thickness of 1/2 inch and it is 1/4 inch thick on top of the mat. It is anchored to the concrete shell by embedded structural tees and studs welded to the liner plate. Headed studs are only used on the 3/4 inch plates in the penetration area. The tees are used in all other regions.

The purpose of these tests is to define a load-deflection curve for the anchors which can be used in the analysis of the liner/anchor system. The liner strains and anchor displacements must meet the requirements of the ASME Section III Division 2 Code.

2. MATERIALS

2.1 Tees

The tees are made from SA36 steel. They were rolled in Japan and accordingly have metric dimensions. The tee WT 100x100 corresponds very closely

with the American WT 4x7.5 (3.94 in. vs 4.0 in. flange width).

## 2.2 Studs

The stud material conforms to ASTM Specification A-108 Grade 1018. The yield stress is approximately 50 ksi and the ultimate strength is approximately 60 ksi.

## 2.3 Liner Plate

The liner plate is made from SA 516 Grade 60 steel (Specification 9763.006 15-1). The plate was cut so that the tensile load on the plate during the test is applied in the direction of rolling. The plate thickness used for all tests, including the studs, was 3/8 inch. In the containment structure the studs are welded to a 3/4 inch plate. It is expected that the thinner plate used in the test will permit larger rotations of the anchor in the vicinity of the plate causing larger stresses in the concrete and thereby conservative results.

## 2.4 Concrete

All concrete was mixed in accordance with PSNH Specification 9763.006 69-7 and 9763-69-3. The design strength was 4000 psi. The concrete mix is the same as used in the containment structure. An air-entraining and retarding admixture was used. The concrete was Atlantic Type II and the coarse aggregate conforms to ASTM C-67.

## 2.5 Reinforcement

The concrete is reinforced with rebar that conforms to ASTM A615 Grade 60 Specifications.



3. DESIGN OF SPECIMENS

The dimensions of the specimens, the reinforcement and pertinent details are shown in the drawing LT-1. The overall size of the specimens and the length and taper of the liner were based on the dimensional limitations of the testing equipment. The reinforcement served two purposes. It first provided a confinement of the concrete and prevented cracking that could occur during transportation and other handling. Also, additional rebar were placed on the side of the tees away from the load application. The purpose of these bars was to prevent overall cracking of the specimen when the test load is applied. They are intended to eliminate failure modes that might occur due to the physical limitations of the test specimen. Any cracking of the free vertical surfaces would not be representative of what could occur in the actual structure which is continuous. The length of the tee specimens was held to 12 inches, to minimize the effect of the free edge.

These problems are not expected to occur when studs are used because the failure will be localized to a small area. The same overall dimensions were used for simplicity of fabrication.

4. POURING PROCEDURE

The test block forms were fabricated at the Seabrook site. The liner formed one side of the form as is the case in the containment structure. The tees were oriented vertically during the pouring operation. Before the concrete was poured a thin coating of WD-40 was sprayed on the liner to eliminate bond between the liner and concrete. Concrete was mixed at the Site Batch Plant and brought to the test area by trucks. The concrete was placed into the forms by a pump truck to simulate actual field placement conditions.

Each specimen was fabricated in three lifts. After each lift a vibrator was used to consolidate the concrete and eliminate voids. Two different trucks were used. Twelve cylinders were taken from each truck. In addition, six cylinders were made for each specimen. These were stored on site in a controlled environment curing room. Three were broken on the day of the test of the specimen. At the end of the pour the top of the concrete surface was troweled to a smooth finish. A chemical curing compound was applied to the exposed surface to seal in moisture and thereby replace water curing.

5. TRANSPORTATION

The specimens were transported to Knoxville, Tennessee on two flatbed trucks 14 days after fabrication. Five day cylinder breaks indicated a strength of 3550 psi.

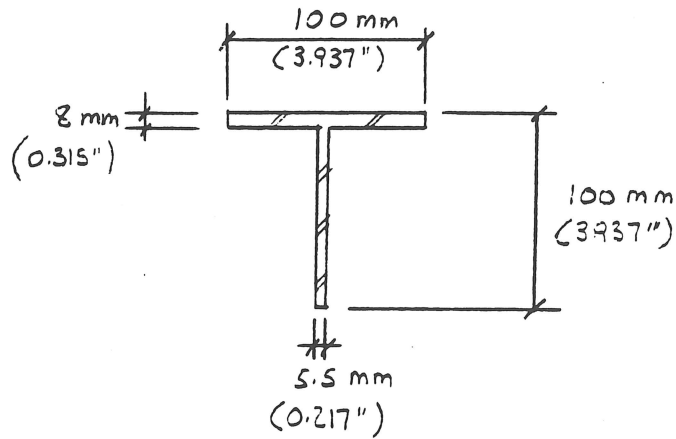

TEE SECTION

FIGURE 1.

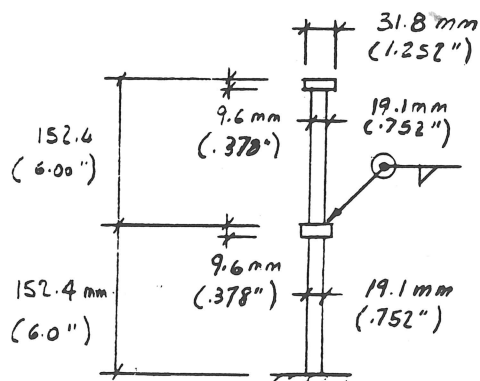

STUD DETAIL

FIGURE 2

3G-58

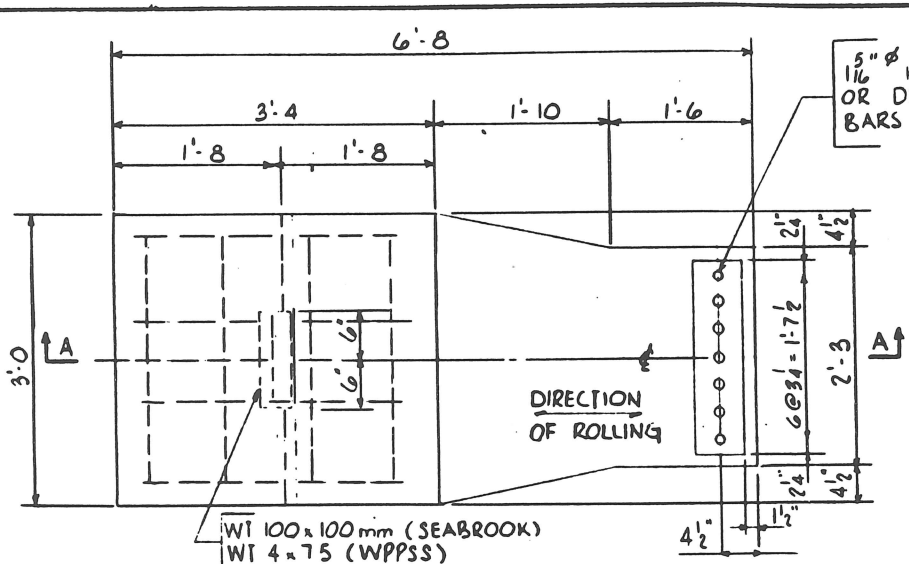

PLAN  
FIGURE #1  
SPECIMEN FOR TESTING TEES  
SCALE: 3/4" = 1'-0"

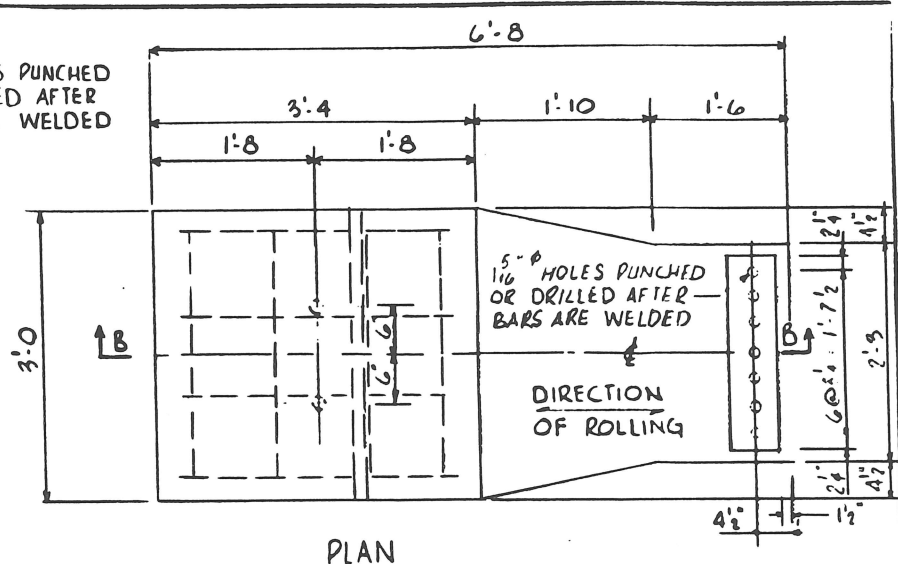

PLAN  
FIGURE #2  
SPECIMEN FOR TESTING STUDS  
SCALE: 3/4" = 1'-0"

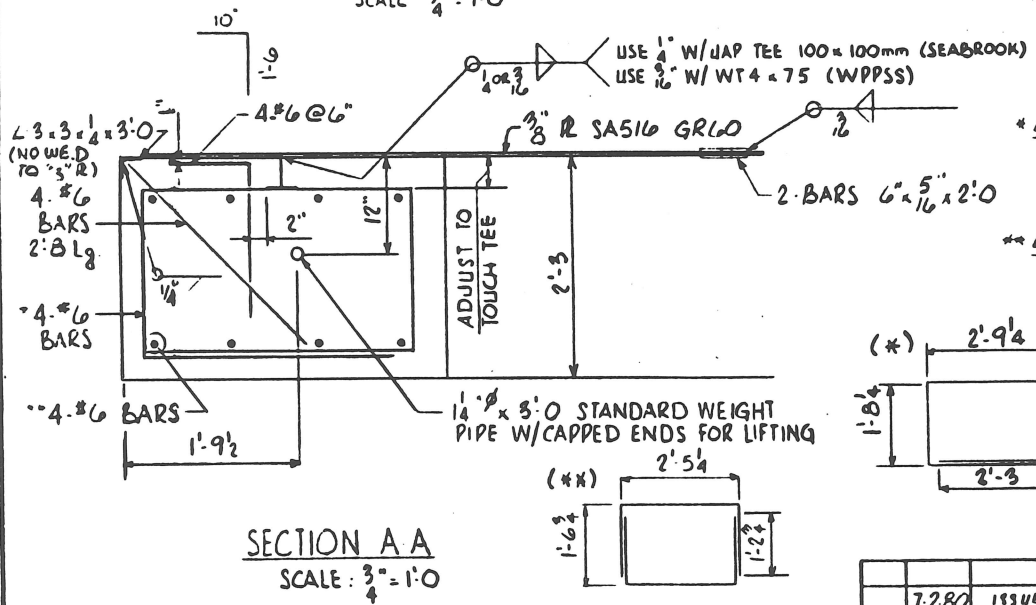

SECTION A-A  
SCALE: 3/4" = 1'-0"

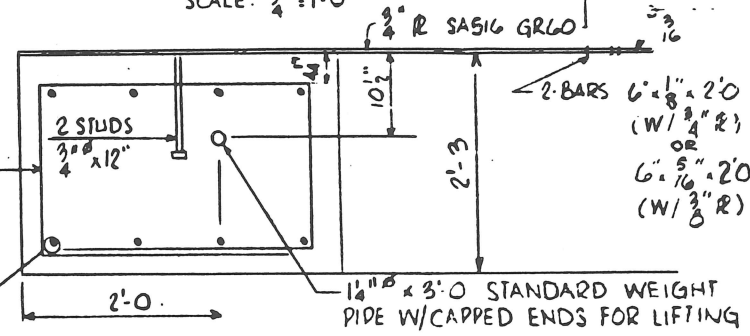

SECTION B-B  
SCALE: 3/4" = 1'-0"

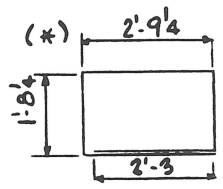

REV. NO.	DATE	DESCRIPTION	ENGR	SUP ENG
7-280		ISSUED FOR CONSTRUCTION	CTM	
51280			B.G.	
5180		FIRST ISSUE	B.G.	

ENGINEER	DATE
STATE REG.	NO.
<b>LINER ANCHOR TEST SPECIMENS</b>	
<div style="border: 1px solid black; padding: 5px; display: inline-block;">LT-1</div>	

SB 1 & 2  
FSAR

Amendment 52  
December 1983



**Plate 1: Close-up of tee welded to liner plate**

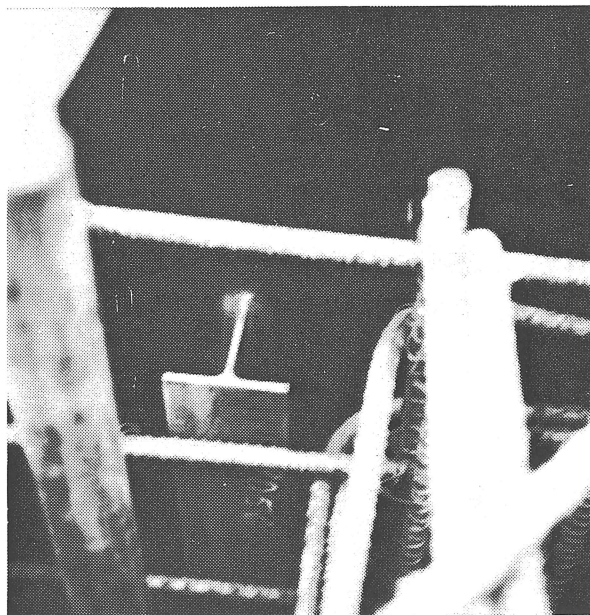

**Plate 2: Reinforcing cage and tee**

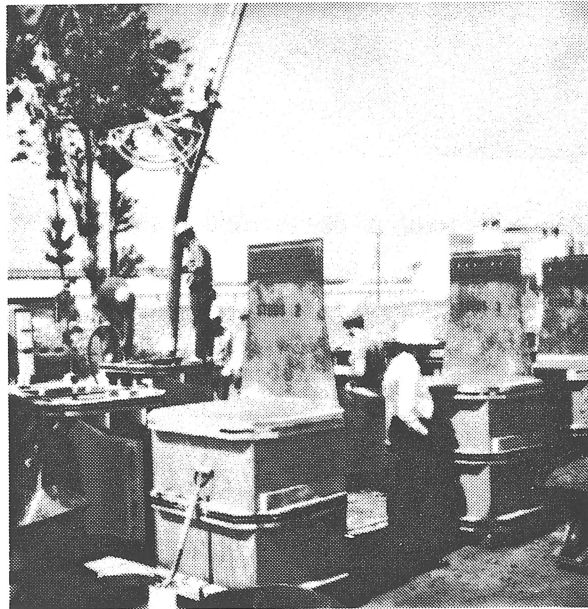

**Plate 3: Finished specimens at end of pouring operation**

SEABROOK UPDATED FSAR

APPENDIX 3H

(Deleted in Amendment 53)