

Attachment to July 18th, 2014
10 C.F.R. 2.206 Enforcement Petition
Florida Power & Light Company
Turkey Point Nuclear Plant

Attachment – Sixteen

USNRC training document – Entitled: Reactor Concepts Manual (28-pages).

Pressurized Water Reactor (PWR) Systems

For a nuclear power plant to perform the function of generating electricity, many different systems must perform their functions. These functions may range from the monitoring of a plant parameter to the controlling of the main turbine or the reactor. This chapter will discuss the purposes of some of the major systems and components associated with a pressurized water reactor.

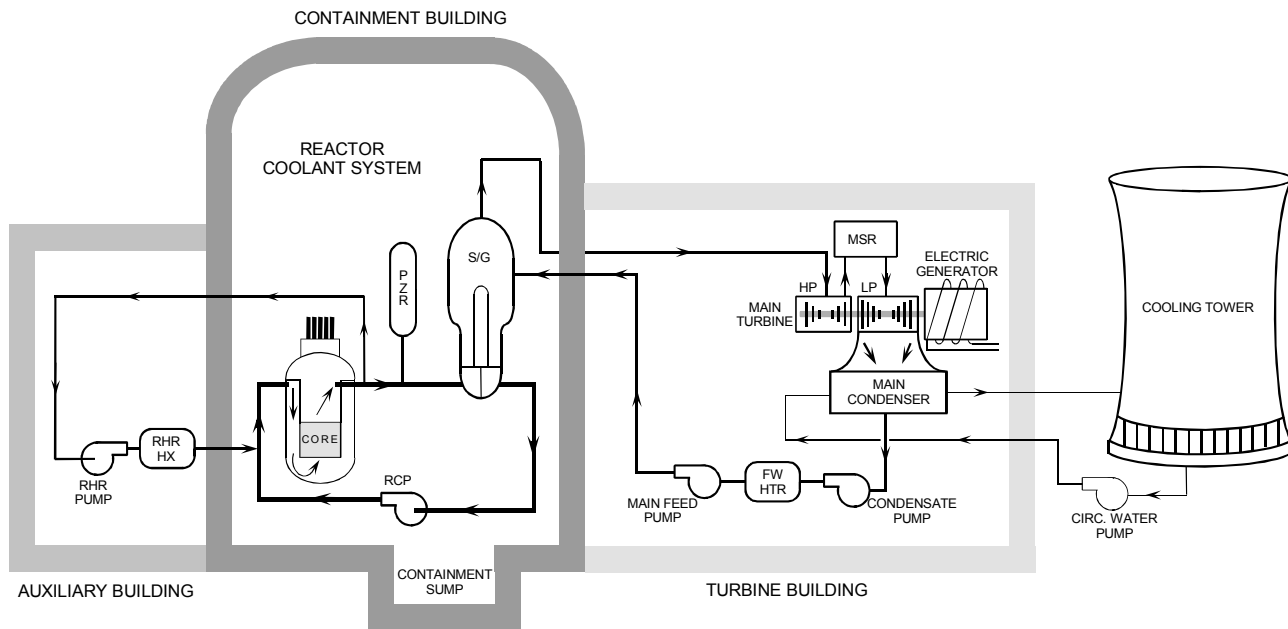

There are two major systems utilized to convert the heat generated in the fuel into electrical power for industrial and residential use. The primary system transfers the heat from the fuel to the steam generator, where the secondary system begins. The steam formed in the steam generator is transferred by the secondary system to the main turbine generator, where it is converted into electricity. After passing through the low pressure turbine, the steam is routed to the main condenser. Cool water, flowing through the tubes in the condenser, removes excess heat from the steam, which allows the steam to condense. The water is then pumped back to the steam generator for reuse.

In order for the primary and secondary systems to perform their functions, there are approximately one hundred support systems. In addition, for emergencies, there are dedicated systems to mitigate the consequences of accidents.

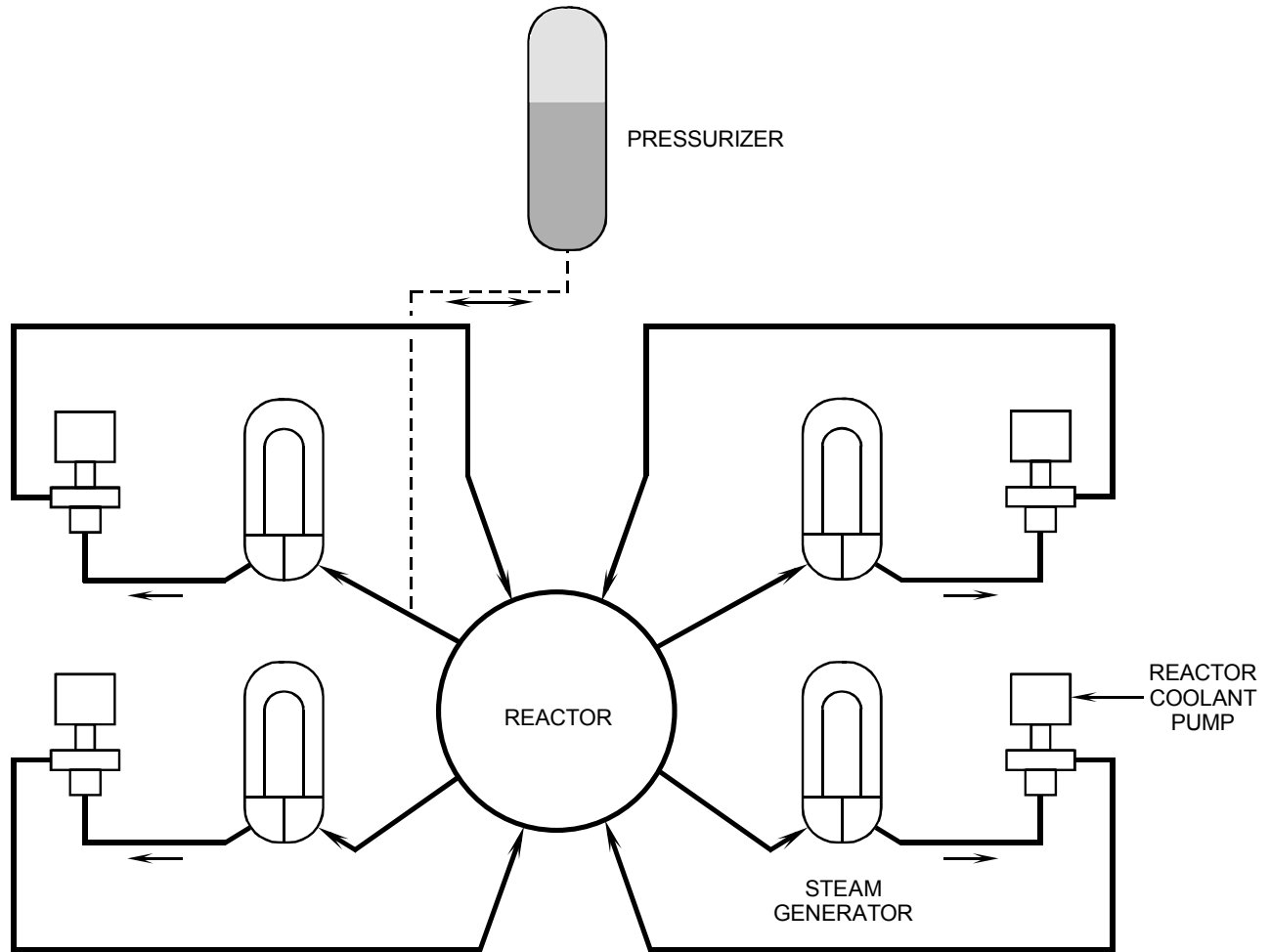

The primary system (also called the Reactor Coolant System) consists of the reactor vessel, the steam generators, the reactor coolant pumps, a pressurizer, and the connecting piping. A reactor coolant loop is a reactor coolant pump, a steam generator, and the piping that connects these components to the reactor vessel. The primary function of the reactor coolant system is to transfer the heat from the fuel to the steam generators. A second function is to contain any fission products that escape the fuel.

The following drawings show the layout of the reactor coolant systems for three pressurized water reactor vendors. All of the systems consist of the same major components, but they are arranged in slightly different ways. For example, Westinghouse has built plant with two, three, or four loops, depending upon the power output of the plant. The Combustion Engineering plants and the Babcock & Wilcox plants only have two steam generators, but they have four reactor coolant pumps.

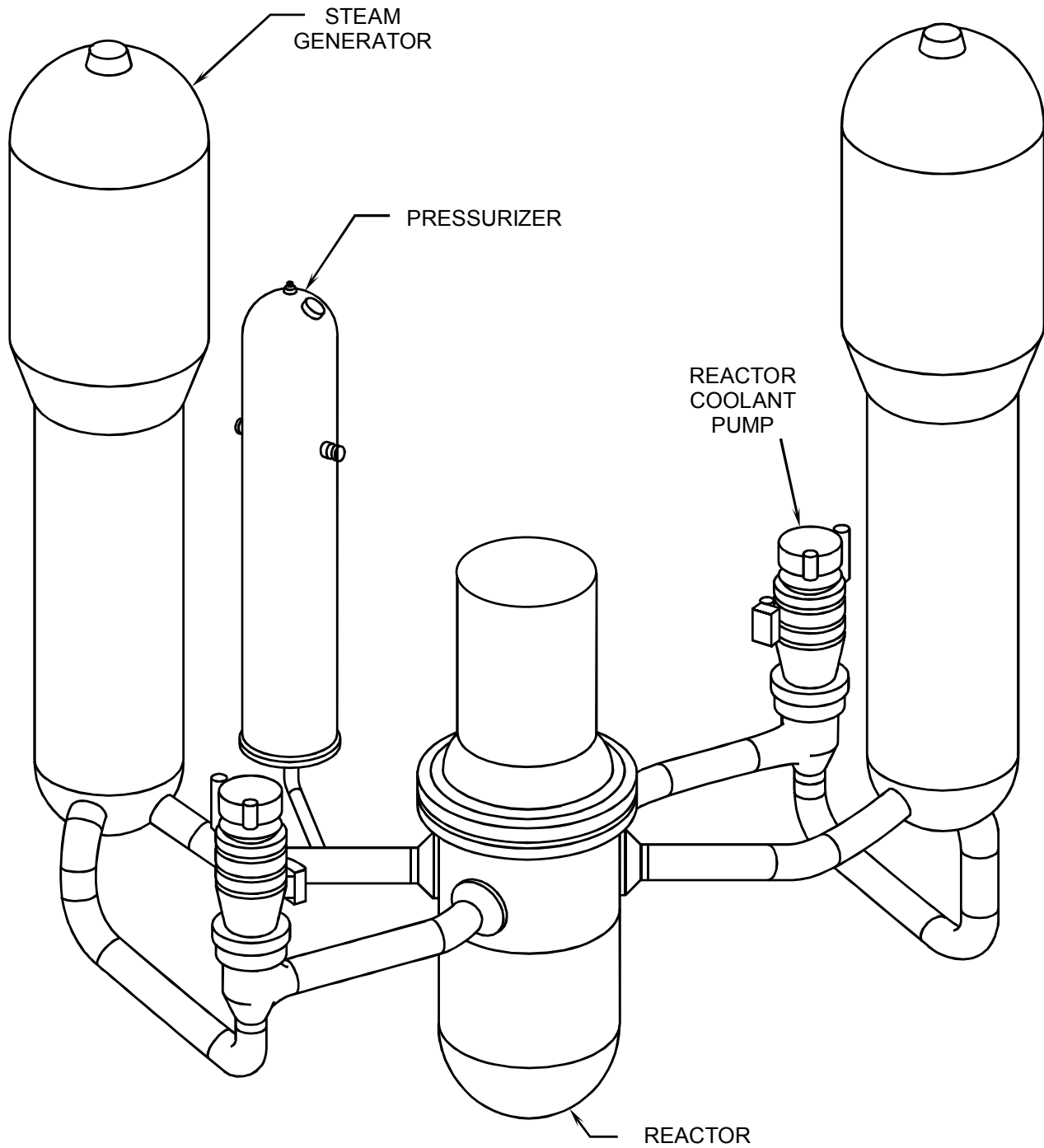

A two-loop Westinghouse plant has two steam generators, two reactor coolant pumps, and a pressurizer. The two-loop units in the United States are Ginna, Kewaunee, Point Beach 1 and 2, and Prairie Island 1 and 2. Each of these plants has 121, 14 x 14 fuel assemblies arranged inside a reactor vessel that has an internal diameter of 132 inches. The electrical output of these plants is approximately 500 megawatts.

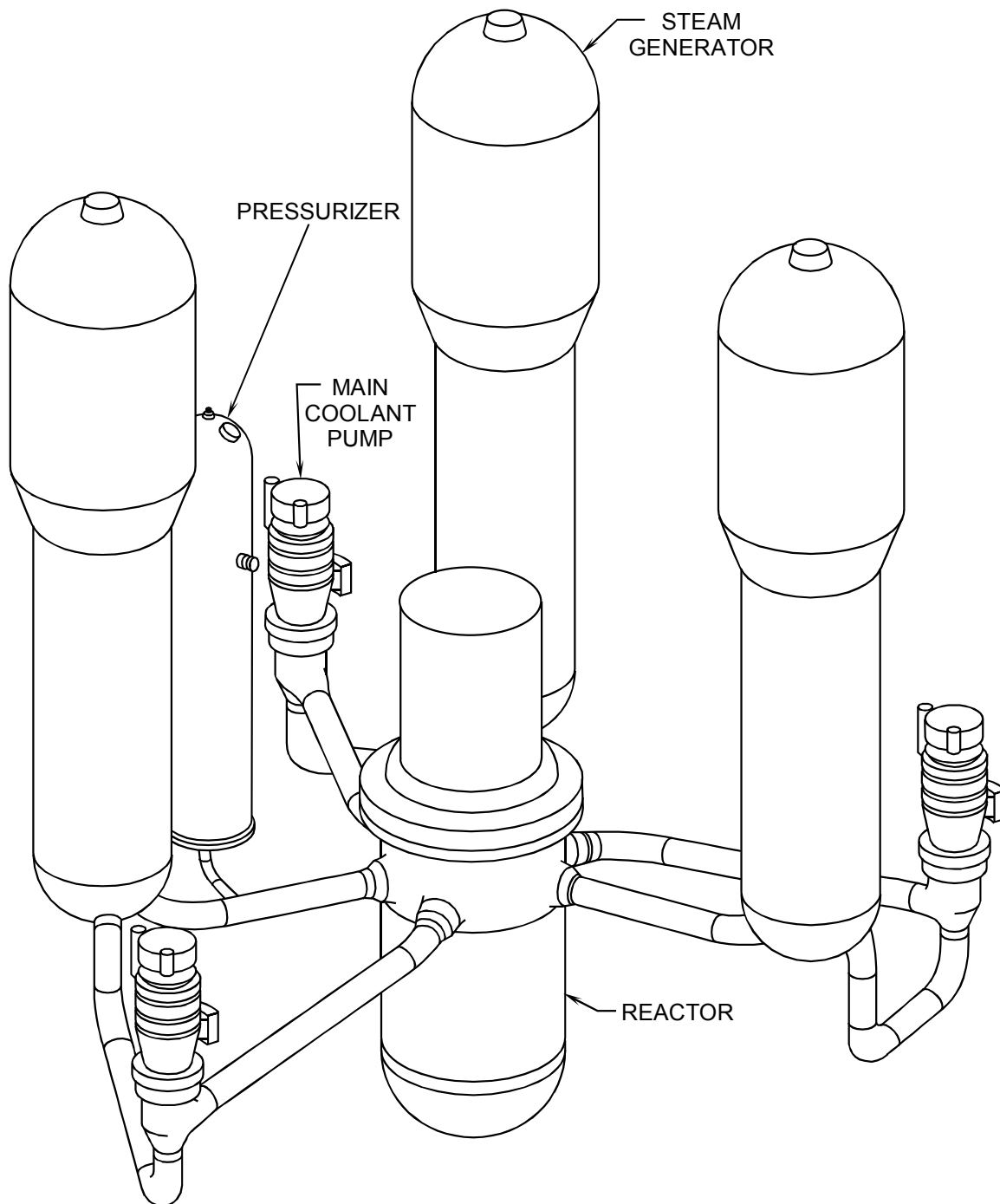

A three-loop Westinghouse plant has three steam generators, three reactor coolant pumps, and a pressurizer. The three-loop units in the United States are Beaver Valley 1 and 2, Farley 1 and 2, H. B. Robinson 2, North Anna 1 and 2, Shearon Harris 1, V. C. Summer, Surry 1 and 2, and Turkey Point 3 and 4. Each of these plants has 157 fuel assemblies. Some units use 15 x 15 fuel assemblies while others use 17 x 17 arrays. The reactor vessels have internal diameters of 156 to 159 inches, except Summer and Turkey Point, which have 172-inch reactor vessels. The electrical output of these plants varies from almost 700 to more than 900 megawatts.

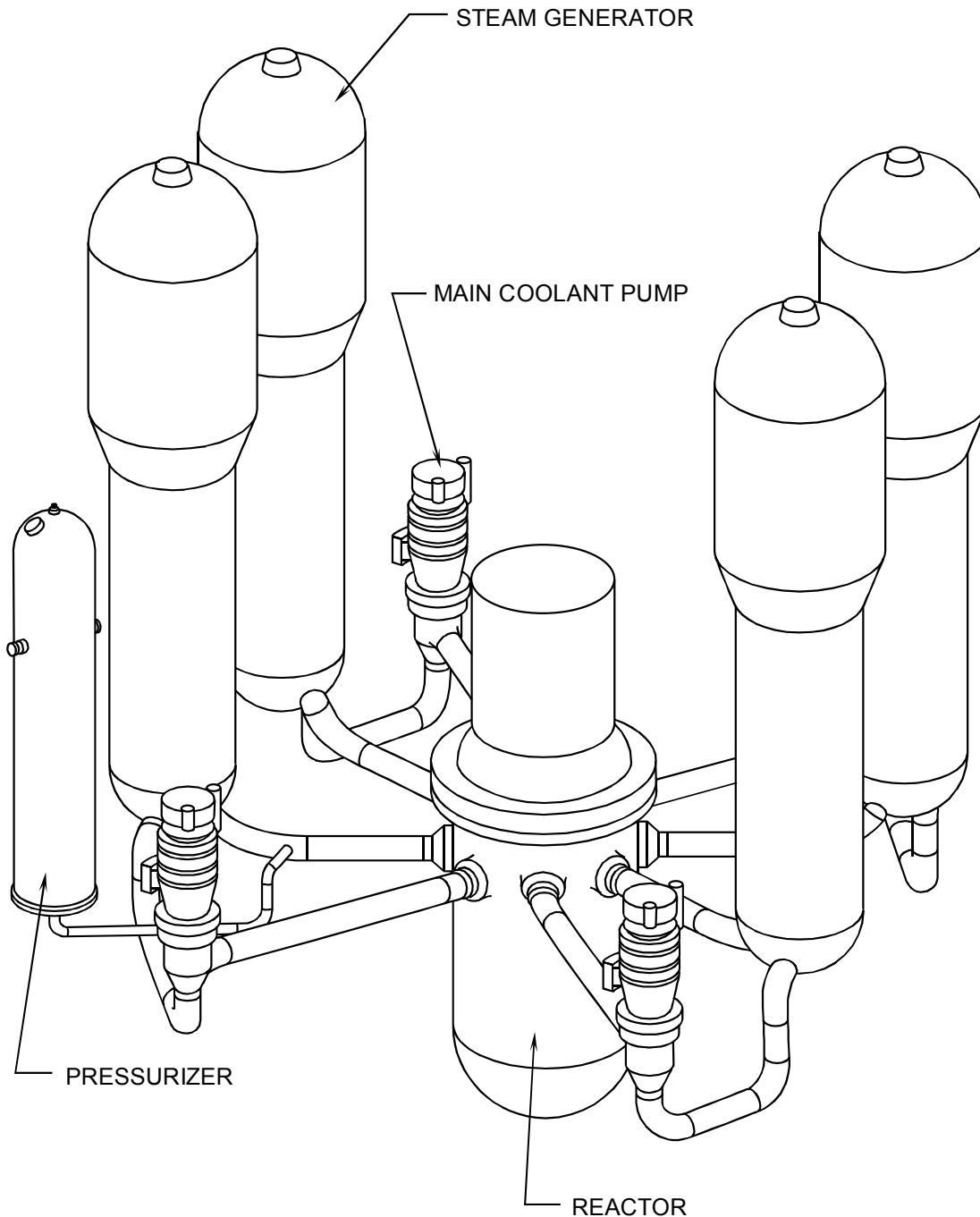

A four-loop Westinghouse plant has four steam generators, four reactor coolant pumps, and a pressurizer. The four-loop units in the United States are Braidwood 1 and 2, Byron 1 and 2, Callaway, Catawba 1 and 2, Comanche Peak 1 and 2, D. C. Cook 1 and 2, Diablo Canyon 1 and 2, Indian Point 2 and 3, McGuire 1 and 2, Millstone 3, Salem 1 and 2, Seabrook, Sequoyah 1 and 2, South Texas Project 1 and 2, Vogtle 1 and 2, Watts Bar 1, and Wolf Creek. Each of these plants has 193 fuel assemblies arranged inside a reactor vessel that has an internal diameter of 173 inches (except South Texas has an internal diameter of 167 inches). The fuel assemblies are arranged in 17 x 17 array except for Cook and Indian Point, which have 15 x 15 fuel. The electrical output of these plants ranges from 950 to 1250 megawatts.

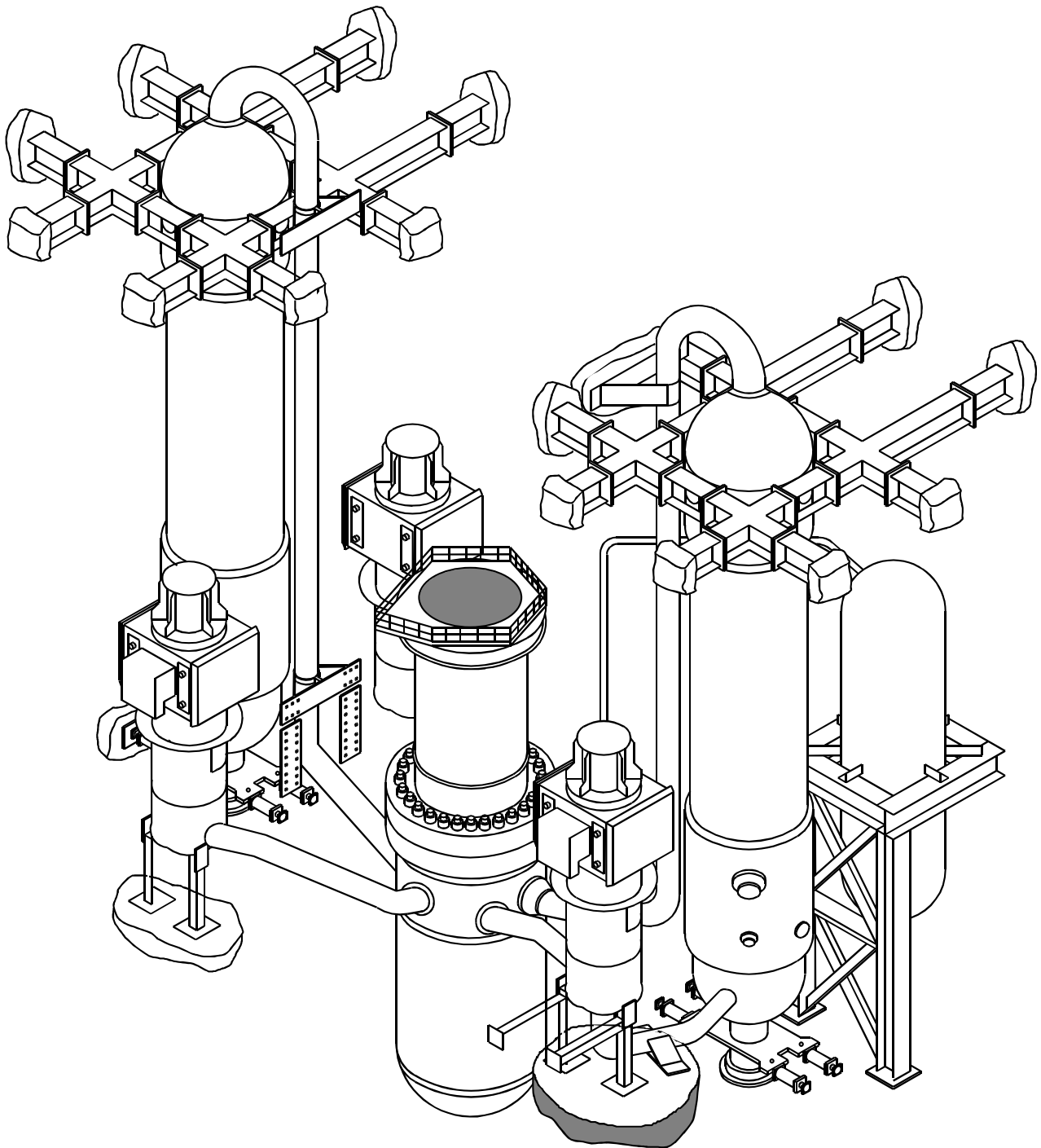

A Babcock & Wilcox plant has two once through steam generators, four reactor coolant pumps, and a pressurizer. The Babcock & Wilcox units in the United States are Arkansas 1, Crystal River 3, Davis Besse, Oconee 1, 2, and 3, and Three Mile Island 1. Each of these plants has 177 fuel assemblies. The electrical output of these plants is approximately 850 megawatts.

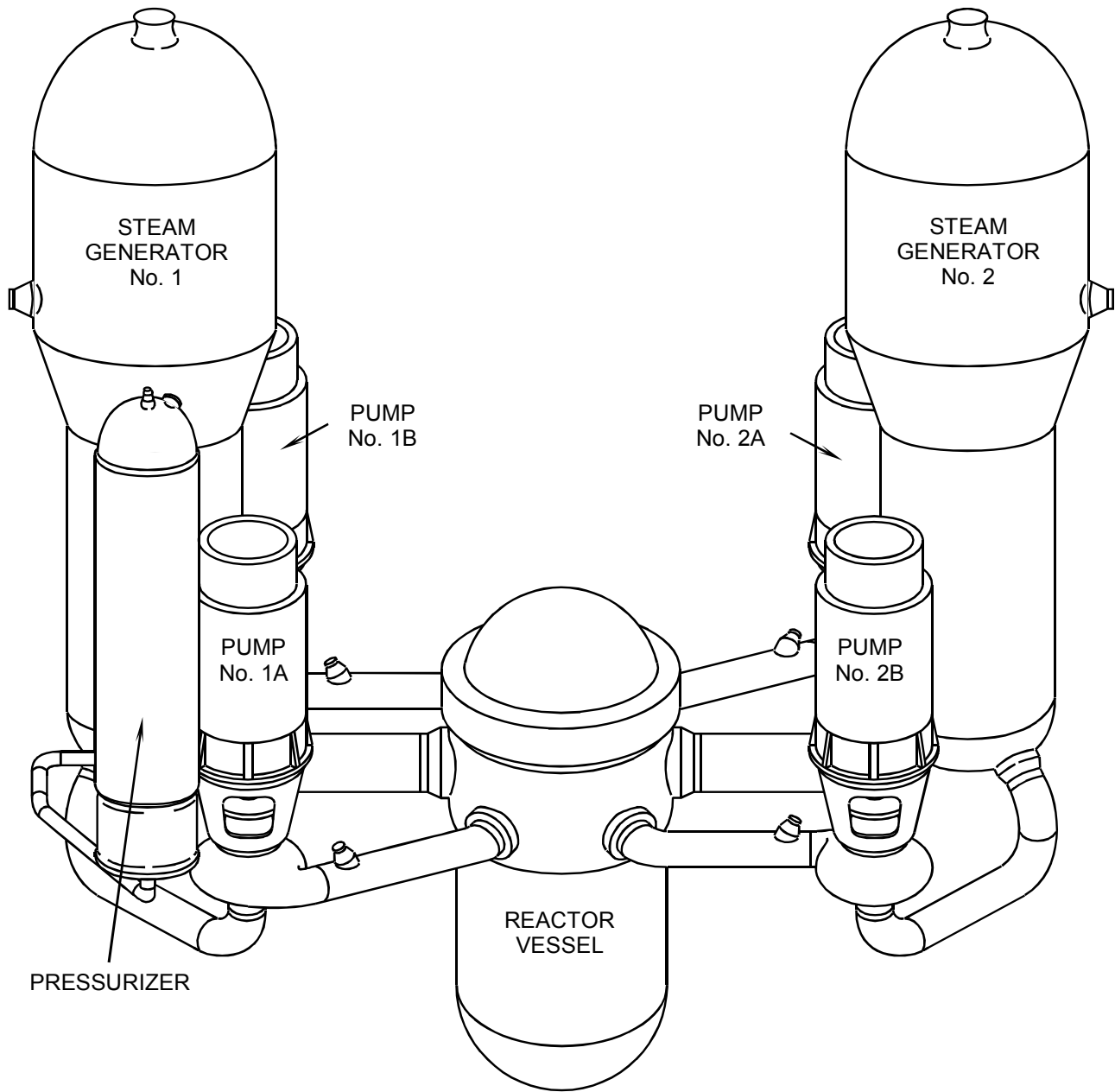

A Combustion Engineering plant has two steam generators, four reactor coolant pumps, and a pressurizer. The Combustion Engineering units in the United States are Arkansas 2, Calvert Cliffs 1 and 2, Fort Calhoun, Millstone 2, Palisades, Palo Verde 1, 2, and 3, San Onofre 2 and 3, Saint Lucie 1 and 2, and Waterford 3. The electrical output of these plants varies from less than 500 to more than 1200 megawatts.

Reactor Vessel

The reactor core, and all associated support and alignment devices, are housed within the reactor vessel (cutaway view on page 4-10). The major components are the reactor vessel, the core barrel, the reactor core, and the upper internals package.

The reactor vessel is a cylindrical vessel with a hemispherical bottom head and a removable hemispherical top head. The top head is removable to allow for the refueling of the reactor. There will be one inlet (or cold leg) nozzle and one outlet (or hot leg) nozzle for each reactor coolant system loop. The reactor vessel is constructed of a manganese molybdenum steel, and all surfaces that come into contact with reactor coolant are clad with stainless steel to increase corrosion resistance.

The core barrel slides down inside of the reactor vessel and houses the fuel. Toward the bottom of the core barrel, there is a lower core support plate on which the fuel assemblies sit. The core barrel and all of the lower internals actually hang inside the reactor vessel from the internals support ledge. On the outside of the core barrel will be irradiation specimen holders in which samples of the material used to manufacture the vessel will be placed. At periodic time intervals, some of these samples will be removed and tested to see how the radiation from the fuel has affected the strength of the material.

The upper internals package sits on top of the fuel. It contains the guide columns to guide the control rods when they are pulled from the fuel. The upper internals package prevents the core from trying to move up during operation due to the force from the coolant flowing through the assemblies.

The flow path for the reactor coolant through the reactor vessel would be:

- The coolant enters the reactor vessel at the inlet nozzle and hits against the core barrel.
- The core barrel forces the water to flow downward in the space between the reactor vessel wall and the core barrel.
- After reaching the bottom of the reactor vessel, the flow is turned upward to pass through the fuel assemblies.
- The coolant flows all around and through the fuel assemblies, removing the heat produced by the fission process.
- The now hotter water enters the upper internals region, where it is routed out the outlet nozzle and goes on to the steam generator.

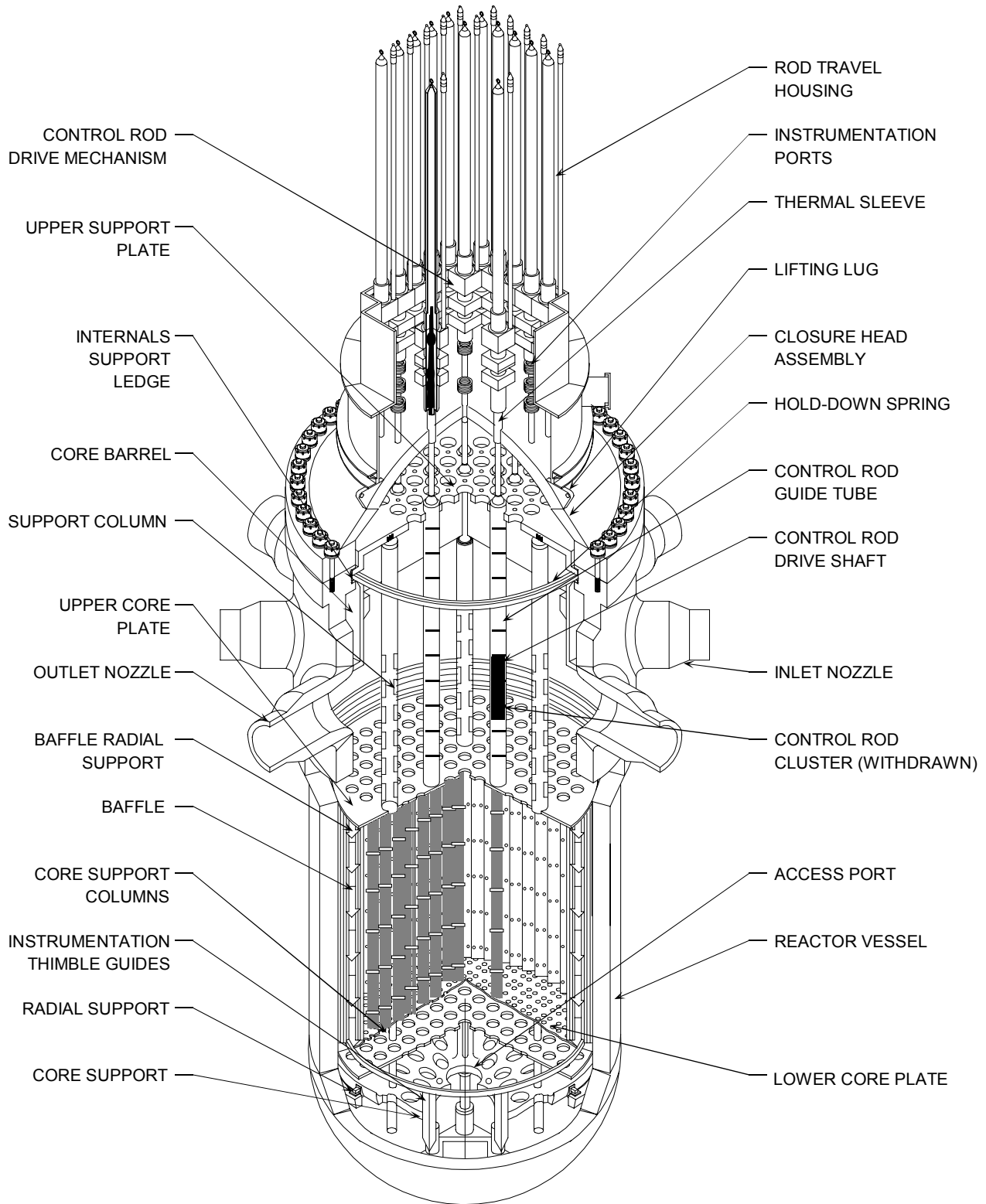

Cutaway View of Reactor Vessel

Steam Generators

The reactor coolant flows from the reactor to the steam generator. Inside of the steam generator, the hot reactor coolant flows inside of the many tubes. The secondary coolant, or feedwater, flows around the outside of the tubes, where it picks up heat from the primary coolant. When the feedwater absorbs sufficient heat, it starts to boil and form steam. At this point, the steam generators used by the three Pressurized Water Reactor vendors differ slightly in their designs and operations.

In the Westinghouse (page 4-12) and Combustion Engineering (page 4-13) designs, the steam/water mixture passes through multiple stages of moisture separation. One stage causes the mixture to spin, which slings the water to the outside. The water is then drained back to be used to make more steam. The drier steam is routed to the second stage of separation. In this stage, the mixture is forced to make rapid changes in direction. Because of the steam's ability to change direction and the water's inability to change, the steam exits the steam generator, and the water is drained back for reuse. The two stage process of moisture removal is so efficient at removing the water that for every 100 pounds of steam that exits the steam generator, the water content is less than 0.25 pounds. It is important to maintain the moisture content of the steam as low as possible to prevent damage to the turbine blading.

The Babcock & Wilcox design uses a once through steam generator (OTSG, page 4-14). In this design, the flow of primary coolant is from the top of the steam generator to the bottom, instead of through U-shaped tubes as in the Westinghouse and Combustion Engineering designs. Because of the heat transfer achieved by this design, the steam that exits the once through steam generator contains no moisture. This is done by heating the steam above the boiling point, or superheating.

Other differences in design include the ways in which the steam and the cooler primary coolant exit the steam generators. In a Westinghouse steam generator, there is a single outlet for the steam and a single outlet for the primary coolant. For both the Babcock & Wilcox design and the Combustion Engineering design there are two steam outlets and two primary coolant outlets.

For all of the steam generator designs, the steam is piped to the main turbine, and the coolant is routed to the suction of the reactor coolant pumps.

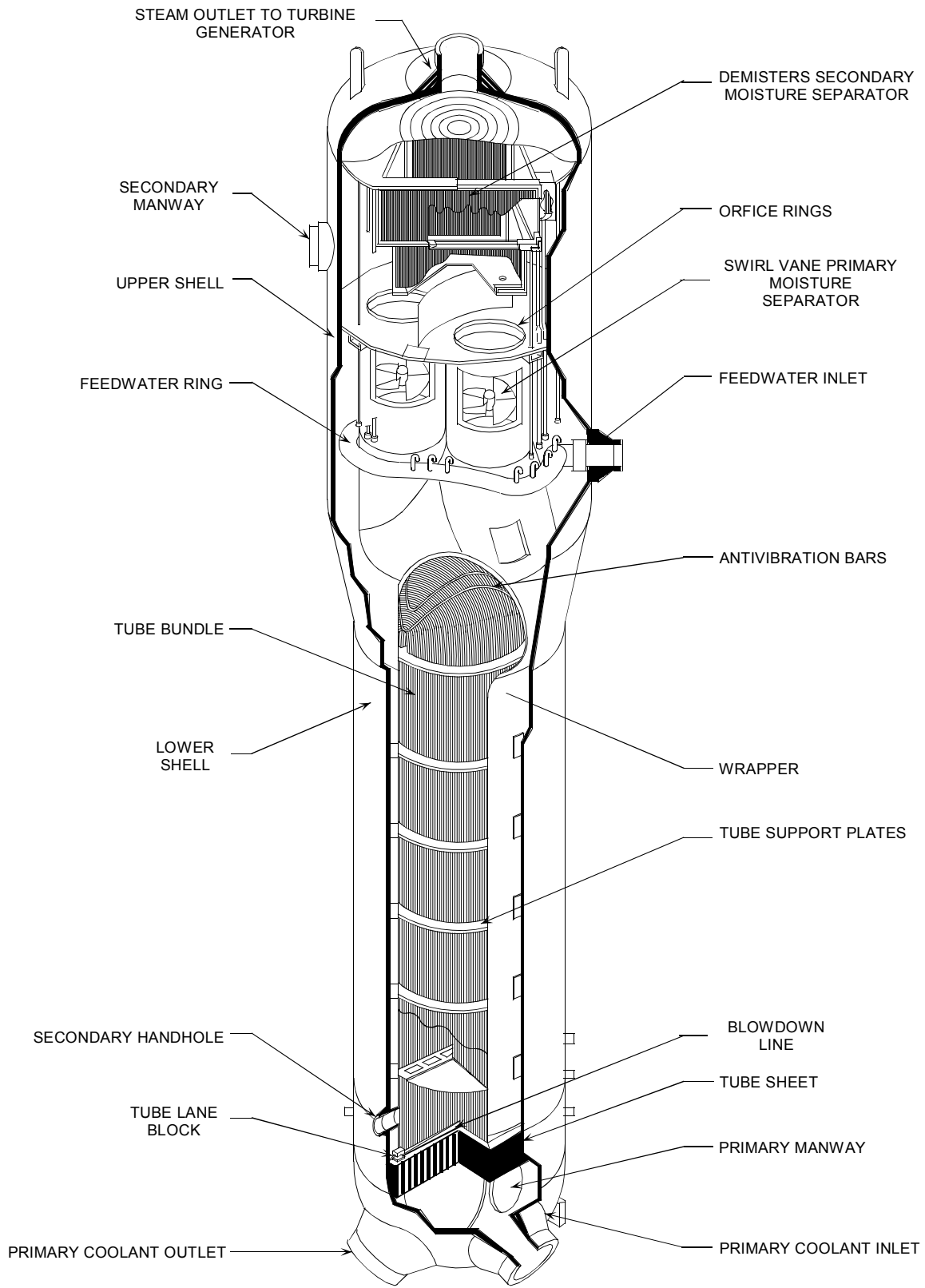

Cutaway View of A Westinghouse Steam Generator

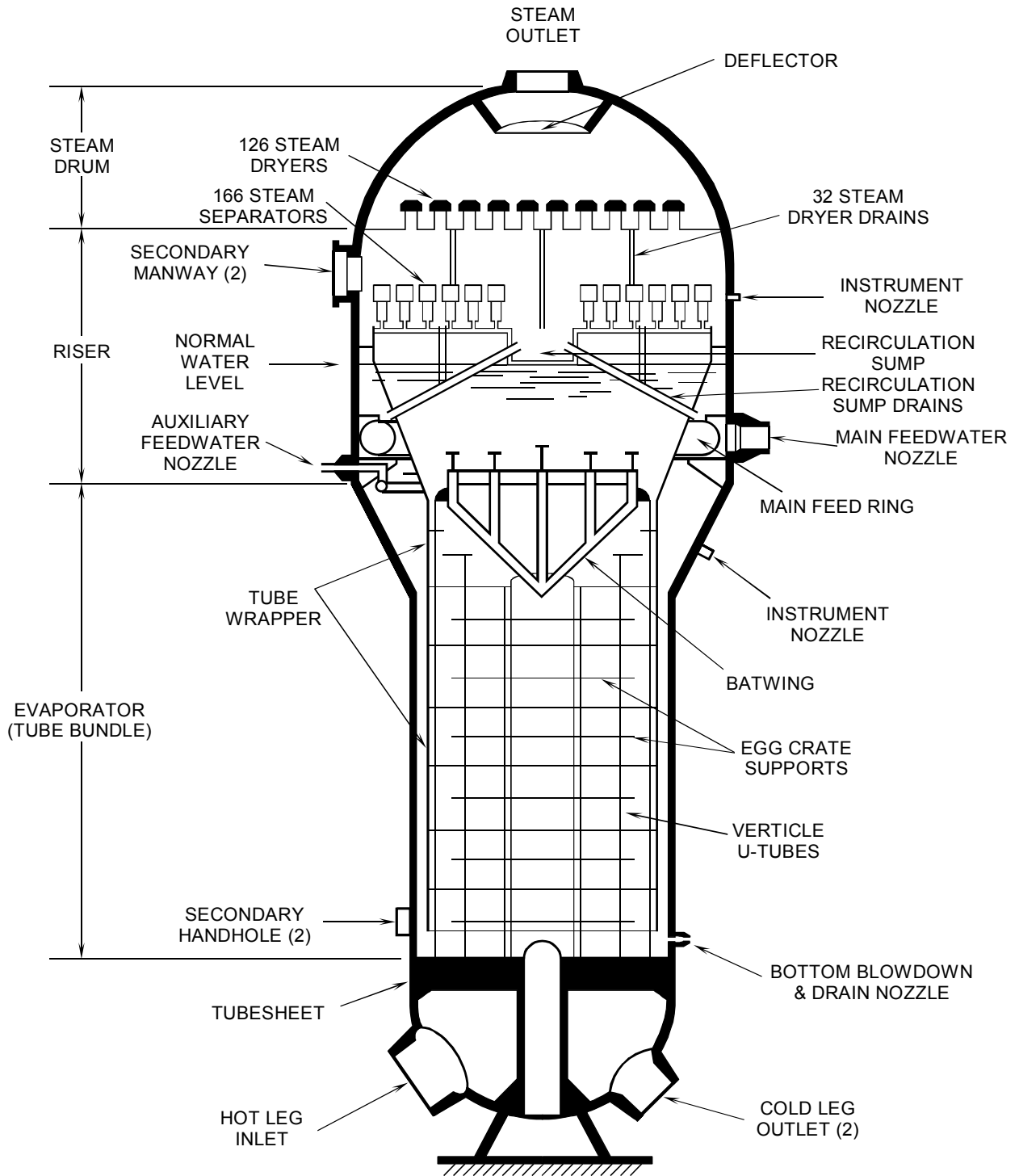

Cutaway View of a Combustion Engineering Steam Generator

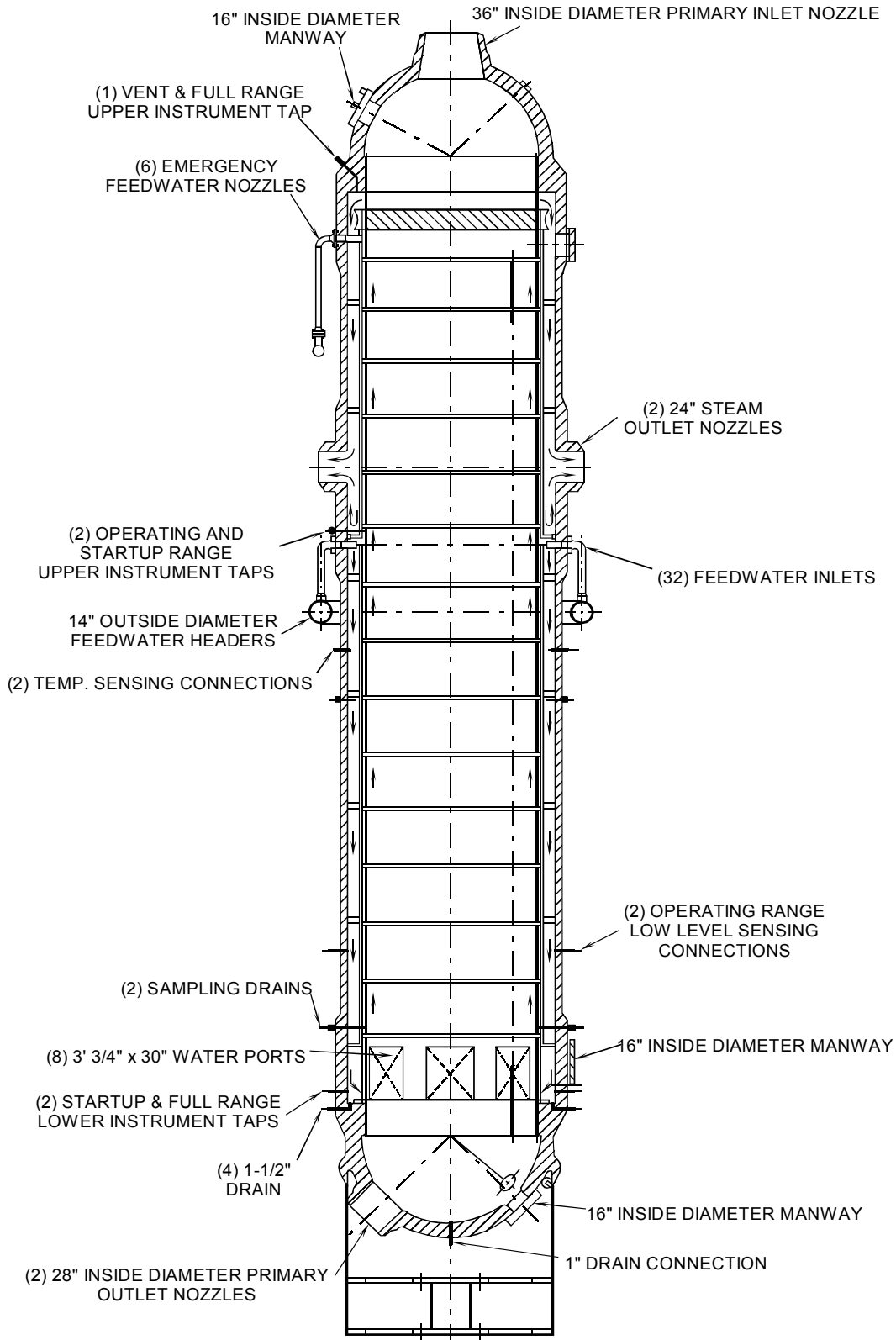

Cutaway View of a Babcock & Wilcox Once Through Steam Generator

Reactor Coolant Pump

The purpose of the reactor coolant pump is to provide forced primary coolant flow to remove the amount of heat being generated by the fission process. Even without a pump, there would be natural circulation flow through the reactor. However, this flow is not sufficient to remove the heat being generated when the reactor is at power. Natural circulation flow is sufficient for heat removal when the plant is shutdown (not critical).

The reactor coolant enters the suction side of the pump from the outlet of the steam generator. The water is increased in velocity by the pump impeller. This increase in velocity is converted to pressure in the discharge volute. At the discharge of the reactor coolant pump, the reactor coolant pressure will be approximately 90 psi higher than the inlet pressure.

After the coolant leaves the discharge side of the pump, it will enter the inlet or cold leg side of the reactor vessel. The coolant will then pass through the fuel to collect more heat and is sent back to the steam generators.

The major components of a reactor coolant pump (page 4-16) are the motor, the hydraulic section, and the seal package.

The motor is a large, air cooled, electric motor. The horsepower rating of the motor will be from 6,000 to 10,000 horsepower. This large amount of power is needed in order to provide the necessary flow of coolant for heat removal (approximately 100,000 gallons per minute per pump).

The hydraulic section of the pump is the impeller and the discharge volute. The impeller of the pump is attached to the motor by a long shaft.

The seal package is located between the motor and the hydraulic section and prevents any water from leaking up the shaft into the containment atmosphere. Any water that does leak up the shaft is collected and routed to the seal leakoff system for collection in various systems.

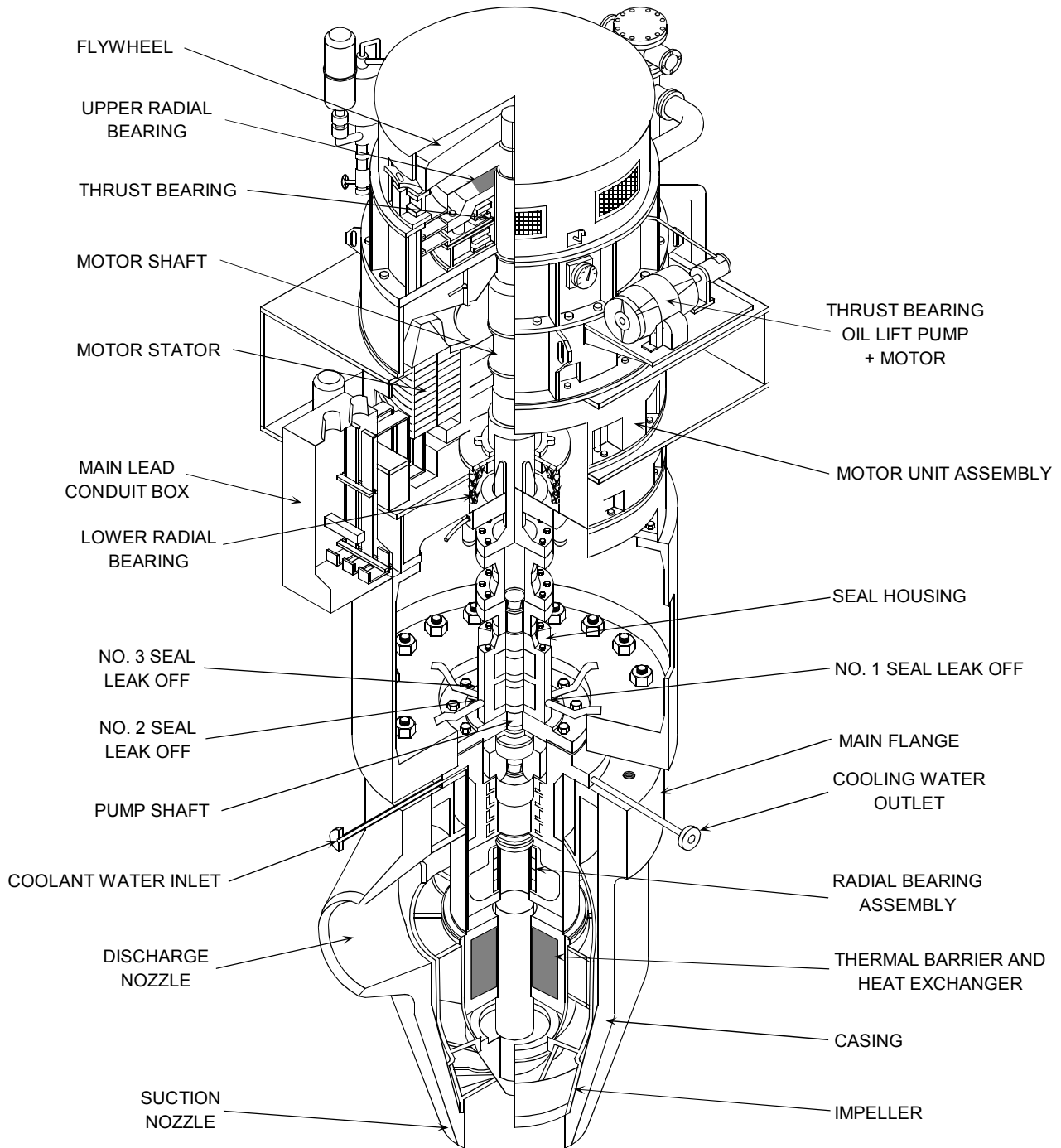

Cutaway View of a Reactor Coolant Pump

Pressurizer

The pressurizer (page 4-18) is the component in the reactor coolant system which provides a means of controlling the system pressure. Pressure is controlled by the use of electrical heaters, pressurizer spray, power operated relief valves, and safety valves.

The pressurizer operates with a mixture of steam and water in equilibrium. If pressure starts to deviate from the desired value, the various components will actuate to bring pressure back to the normal operating point. The cause of the pressure deviation is normally associated with a change in the temperature of the reactor coolant system. If reactor coolant system temperature starts to increase, the density of the reactor coolant will decrease, and the water will take up more space. Since the pressurizer is connected to the reactor coolant system via the surge line, the water will expand up into the pressurizer. This will cause the steam in the top of the pressurizer to be compressed, and therefore, the pressure to increase.

The opposite effect will occur if the reactor coolant system temperature decreases. The water will become more dense, and will occupy less space. The level in the pressurizer will decrease, which will cause a pressure decrease. For a pressure increase or decrease, the pressurizer will operate to bring pressure back to normal.

For example, if pressure starts to increase above the desired setpoint, the spray line will allow relatively cold water from the discharge of the reactor coolant pump to be sprayed into the steam space. The cold water will condense the steam into water, which will reduce pressure (due to the fact that steam takes up about six times more space than the same mass of water). If pressure continues to increase, the pressurizer relief valves will open and dump steam to the pressurizer relief tank. If this does not relieve pressure, the safety valves will lift, also discharging to the pressurizer relief tank.

If pressure starts to decrease, the electrical heaters will be energized to boil more water into steam, and therefore increase pressure. If pressure continues to decrease, and reaches a predetermined setpoint, the reactor protection system will trip the reactor.

The pressurizer relief tank (page 4-19) is a large tank containing water with a nitrogen atmosphere. The water is there to condense any steam discharged by the safety or relief valves. Since the reactor coolant system contains hydrogen, the nitrogen atmosphere is used to prevent the hydrogen from existing in a potentially explosive environment.

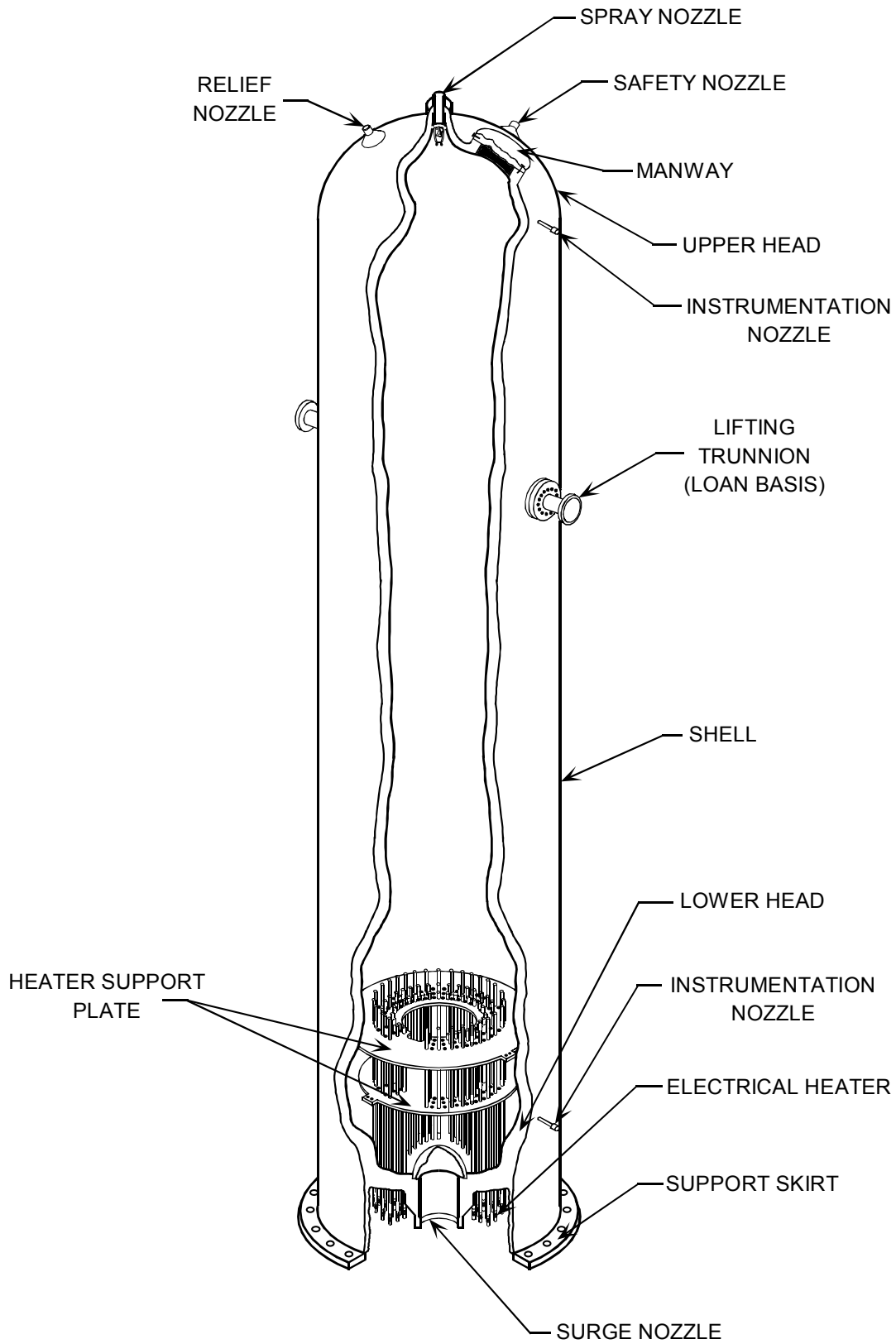

Cutaway View of a Pressurizer

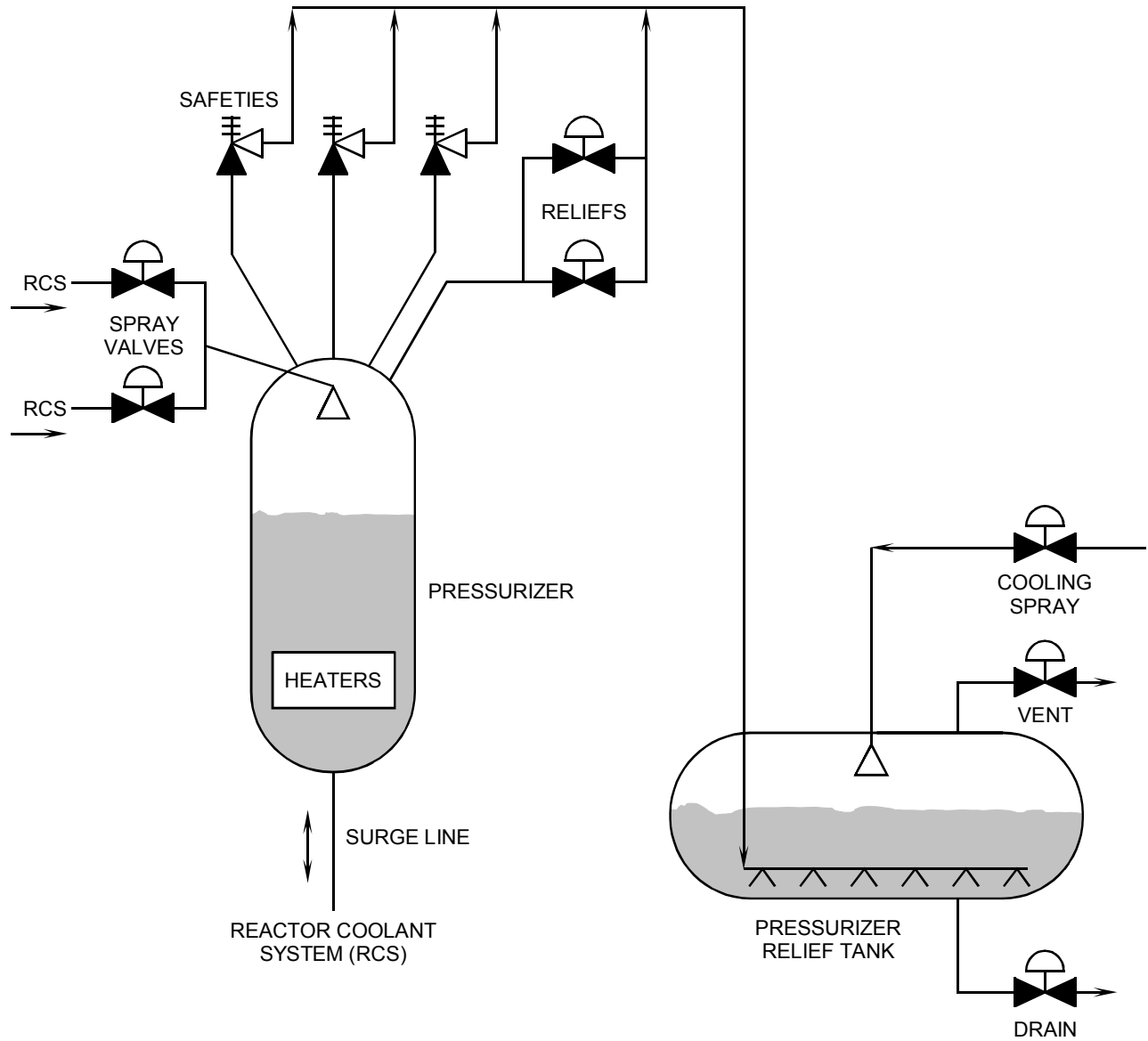

Pressurizer and Pressurizer Relief Tank

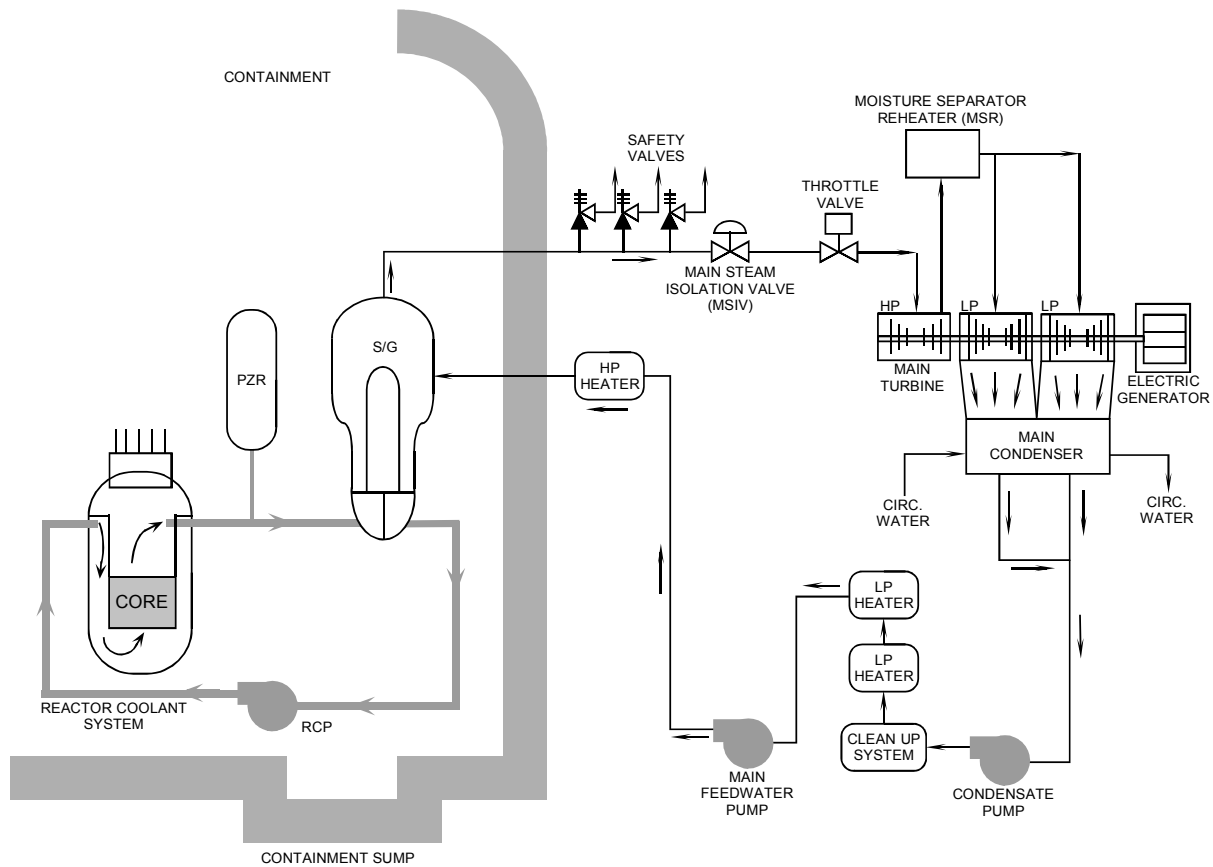

The major secondary systems of a pressurized water reactor are the main steam system and the condensate/feedwater system. Since the primary and secondary systems are physically separated from each other (by the steam generator tubes), the secondary system will contain little or no radioactive material.

The main steam system starts at the outlet of the steam generator. The steam is routed to the high pressure main turbine. After passing through the high pressure turbine, the steam is piped to the moisture separator/reheaters (MSRs). In the MSRs, the steam is dried with moisture separators and reheated using other steam as a heat source. From the MSRs, the steam goes to the low pressure turbines. After passing through the low pressure turbines, the steam goes to the main condenser, which is operated at a vacuum to allow for the greatest removal of energy by the low pressure turbines. The steam is condensed into water by the flow of circulating water through the condenser tubes.

At this point, the condensate/feedwater system starts. The condensed steam collects in the hotwell area of the main condenser. The condensate pumps take a suction on the hotwell to increase the pressure of the water. The condensate then passes through a cleanup system to remove any impurities in the water. This is necessary because the steam generator acts as a concentrator. If the impurities are not removed, they will be left in the steam generator after the steam forming process, and this could reduce the heat transfer capability of the steam generator and/or damage the steam generator tubes. The condensate then passes through some low pressure feedwater heaters. The temperature of the condensate is increased in the heaters by using steam from the low pressure turbine (extraction steam). The condensate flow then enters the suction of the main feedwater pumps, which increases the pressure of the water high enough to enter the steam generator. The feedwater now passes through a set of high pressure feedwater heaters, which are heated by extraction steam from the high pressure turbine (heating the feedwater helps to increase the efficiency of the plant). The flow rate of the feedwater is controlled as it enters the steam generators.

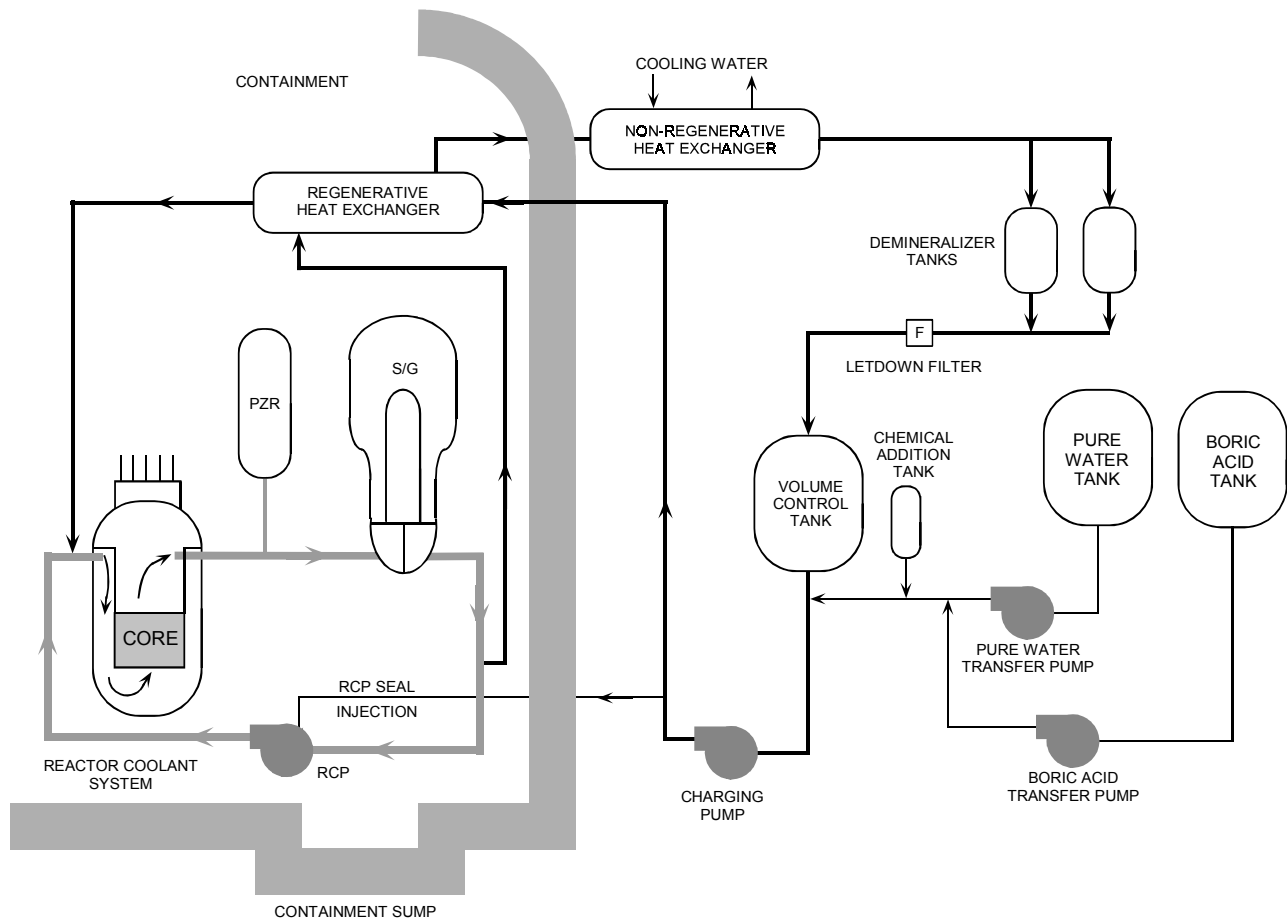

The chemical and volume control system (CVCS) is a major support system for the reactor coolant system. Some of the functions of the system are to:

- Purify the reactor coolant system using filters and demineralizers,
- Add and remove boron as necessary, and
- Maintain the level of the pressurizer at the desired setpoint.

A small amount of water (about 75 gpm) is continuously routed through the chemical and volume control system (called letdown). This provides a continuous cleanup of the reactor coolant system which maintains the purity of the coolant and helps to minimize the amount of radioactive material in the coolant.

The reactor coolant pump seals prevent the leakage of primary coolant to the containment atmosphere. The chemical and volume control system provides seal injection to keep the seals cool and provide lubrication for the seals. This water has been cooled by the heat exchangers and cleaned by the filters and demineralizers.

There is also a path (not shown) to route the letdown flow to the radioactive waste system for processing and/or disposal.

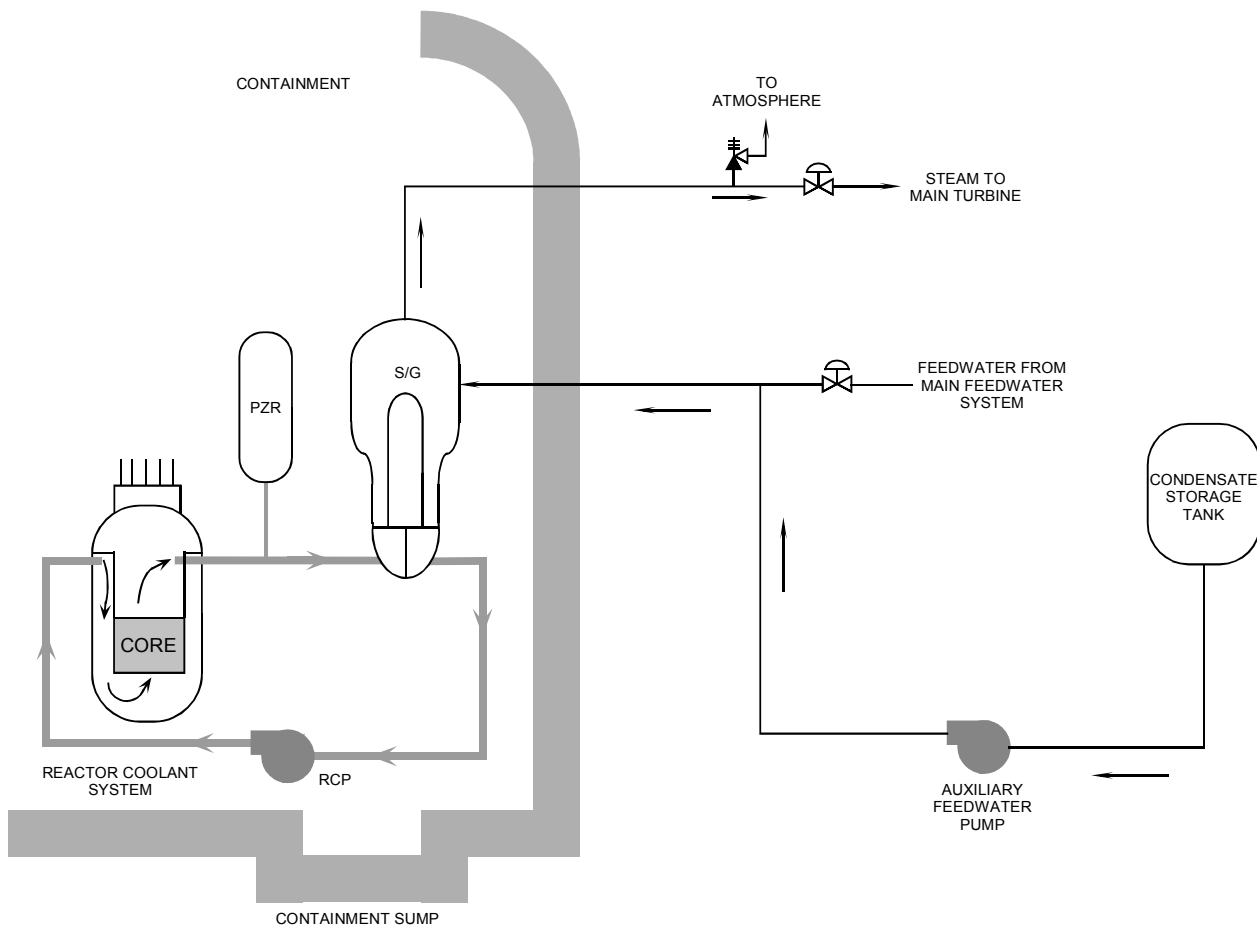

During normal operation, the heat produced by the fission process is removed by the reactor coolant and transferred to the secondary coolant in the steam generators. Here, the secondary coolant is boiled into steam and sent to the main turbine.

Even after the reactor has been shutdown, there is a significant amount of heat produced by the decay of fission products (decay heat). The amount of heat produced by decay heat is sufficient to cause fuel damage if not removed. Therefore, systems must be designed and installed in the plant to remove the decay from the core and transfer that heat to the environment, even in a shutdown plant condition. Also, if it is desired to perform maintenance on reactor coolant system components, the temperature and pressure of the reactor coolant system must be reduced low enough to allow personnel access to the equipment.

The auxiliary feedwater system and the steam dump system (turbine bypass valves) work together to allow the operators to remove the decay heat from the reactor. The auxiliary feedwater system pumps water from the condensate storage tank to the steam generators. This water is allowed to boil to make steam. The steam can then be dumped to the main condenser through the steam dump valves. The circulating water will then condense the steam and take the heat to the environment.

If the steam dump system is not available (for example, no circulating water for the main condenser), the steam can be dumped directly to the atmosphere through the atmospheric relief valves.

By using either method of steam removal, the heat is being removed from the reactor coolant system, and the temperature of the reactor coolant system can be reduced to the desired level.

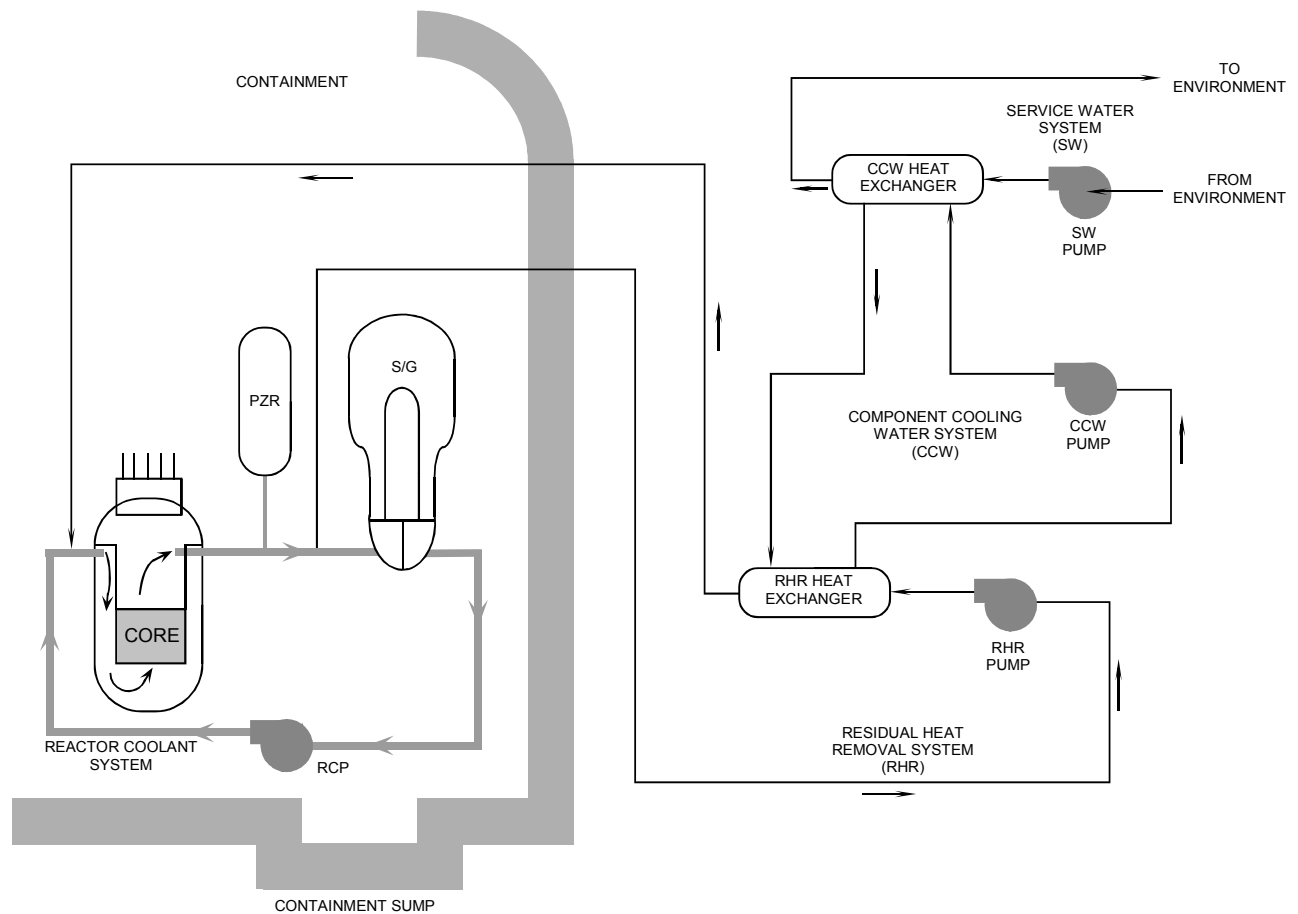

At some point, the decay heat being produced will not be sufficient to generate enough steam in the steam generators to continue the cooldown. When the reactor coolant system pressure and temperature have been reduced to within the operational limits, the residual heat removal system (RHR) will be used to continue the cooldown by removing heat from the core and transferring it to the environment.

This is accomplished by routing some of the reactor coolant through the residual heat removal system heat exchanger, which is cooled by the component cooling water system (CCW). The heat removed by the component cooling water system is then transferred to the service water system in the component cooling water heat exchanger. The heat picked up by the service water system will be transferred directly to the environment from the service water system.

The residual heat removal system can be used to cool the plant down to a low enough temperature that personnel can perform any maintenance functions, including refueling.

Emergency Core Cooling Systems

There are two purposes of the emergency core cooling systems (ECCS). The first is to provide core cooling to minimize fuel damage following a loss of coolant accident. This is accomplished by the injection of large amounts of cool, borated water into the reactor coolant system. The second is to provide extra neutron poisons to ensure the reactor remains shutdown following the cooldown associated with a main steam line rupture, which is accomplished by the use of the same borated water source. This water source is called the refueling water storage tank (RWST).

To perform this function of injection of large quantities of borated water, the emergency core cooling systems consist of four separate systems (page 4-25). In order of highest pressure to lowest pressure, these systems are: the high pressure injection (or charging) system, the intermediate pressure injection system, the cold leg accumulators, and the low pressure injection system (residual heat removal). Even though the diagram shows only one pump in each system, there are actually two, each of which is capable of providing sufficient flow. Also, these systems must be able to operate when the normal supply of power is lost to the plant. For this reason, these systems are powered from the plant emergency (diesel generators) power system.

The high pressure injection system uses the pumps in the chemical and volume control system. Upon receipt of an emergency actuation signal, the system will automatically realign to take water from the refueling water storage tank and pump it into the reactor coolant system. The high pressure injection system is designed to provide water to the core during emergencies in which reactor coolant system pressure remains relatively high (such as small break in the reactor coolant system, steam break accidents, and leaks of reactor coolant through a steam generator tube to the secondary side).

The intermediate pressure injection system is also designed for emergencies in which the primary pressure stays relatively high, such as small to intermediate size primary breaks. Upon an emergency start signal, the pumps will take water from the refueling water storage tank and pump it into the reactor coolant system.

The cold leg accumulators do not require electrical power to operate. These tanks contain large amounts of borated water with a pressurized nitrogen gas bubble in the top. If the pressure of the primary system drops below low enough, the nitrogen will force the borated water out of the tank and into the reactor coolant system. These tanks are designed to provide water to the reactor coolant system during emergencies in which the pressure of the primary drops very rapidly, such as large primary breaks.

The low pressure injection system (residual heat removal) is designed to inject water from the refueling water storage tank into the reactor coolant system during large breaks, which would cause a very low reactor coolant system pressure. In addition, the residual heat removal system has a feature that allows it to take water from the containment sump, pump it through the residual heat removal system heat exchanger for cooling, and then send the cooled water back to the reactor for core cooling. This is the method of cooling that will be used when the refueling water storage tank goes empty after a large primary system break. This is called the long term core cooling or recirculation mode.

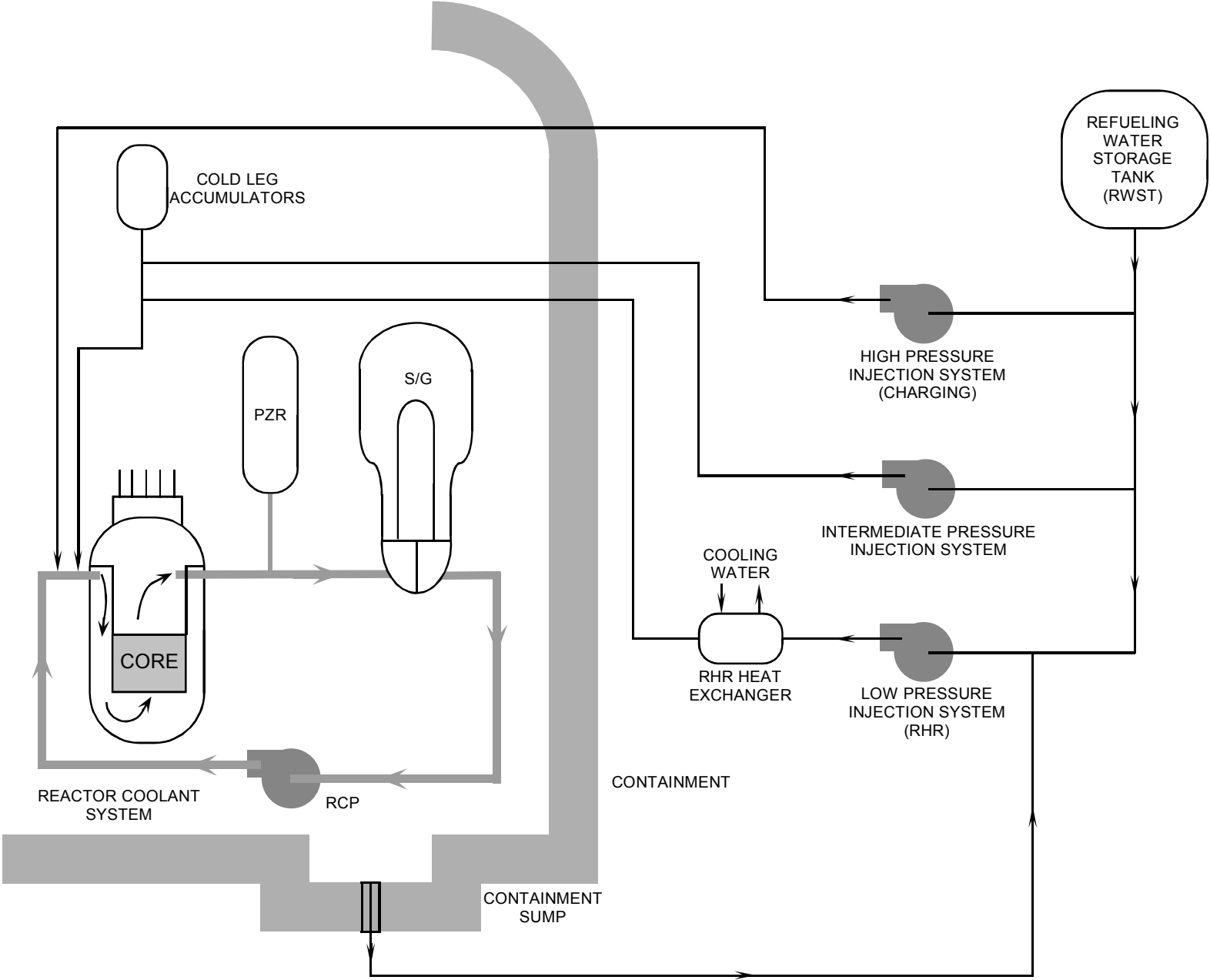

Emergency Core Cooling Systems

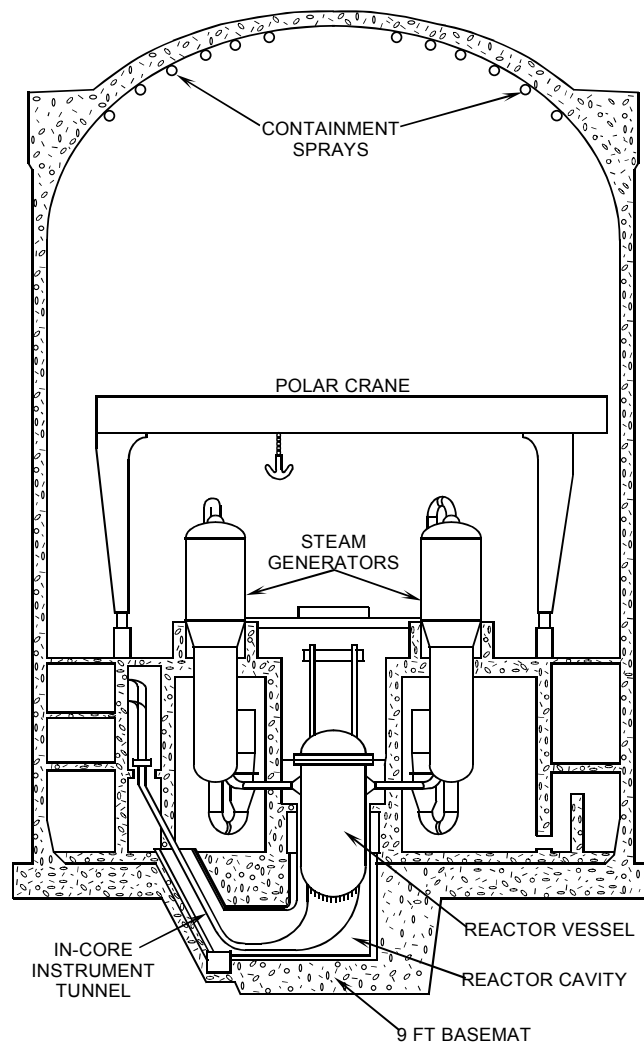

As discussed in previous chapters, the reactor coolant system is located inside the containment building. Containments are designed to withstand the pressures and temperatures that would accompany a high energy fluid (primary coolant, steam, or feedwater) release into the building, but exposure to high temperature and pressure over a long period of time would tend to degrade the concrete. If a break occurred in the primary system, the coolant that is released into the containment building would contain radioactive material (fission products). If the concrete developed any cracks, the high pressure in the containment would tend to force the radioactive material out of the containment and into the environment.

To limit the leakage out of containment following an accident, there is a steel liner that covers the inside surface of the containment building. This liner acts as a vapor proof membrane to prevent any gas from escaping through any cracks that may develop in the concrete.

There are also two systems designed with the purpose of reducing containment temperature and pressure after an accident in the containment building. The fan cooler system circulates the air through heat exchangers to accomplish the cooling. The second system is the containment spray system.

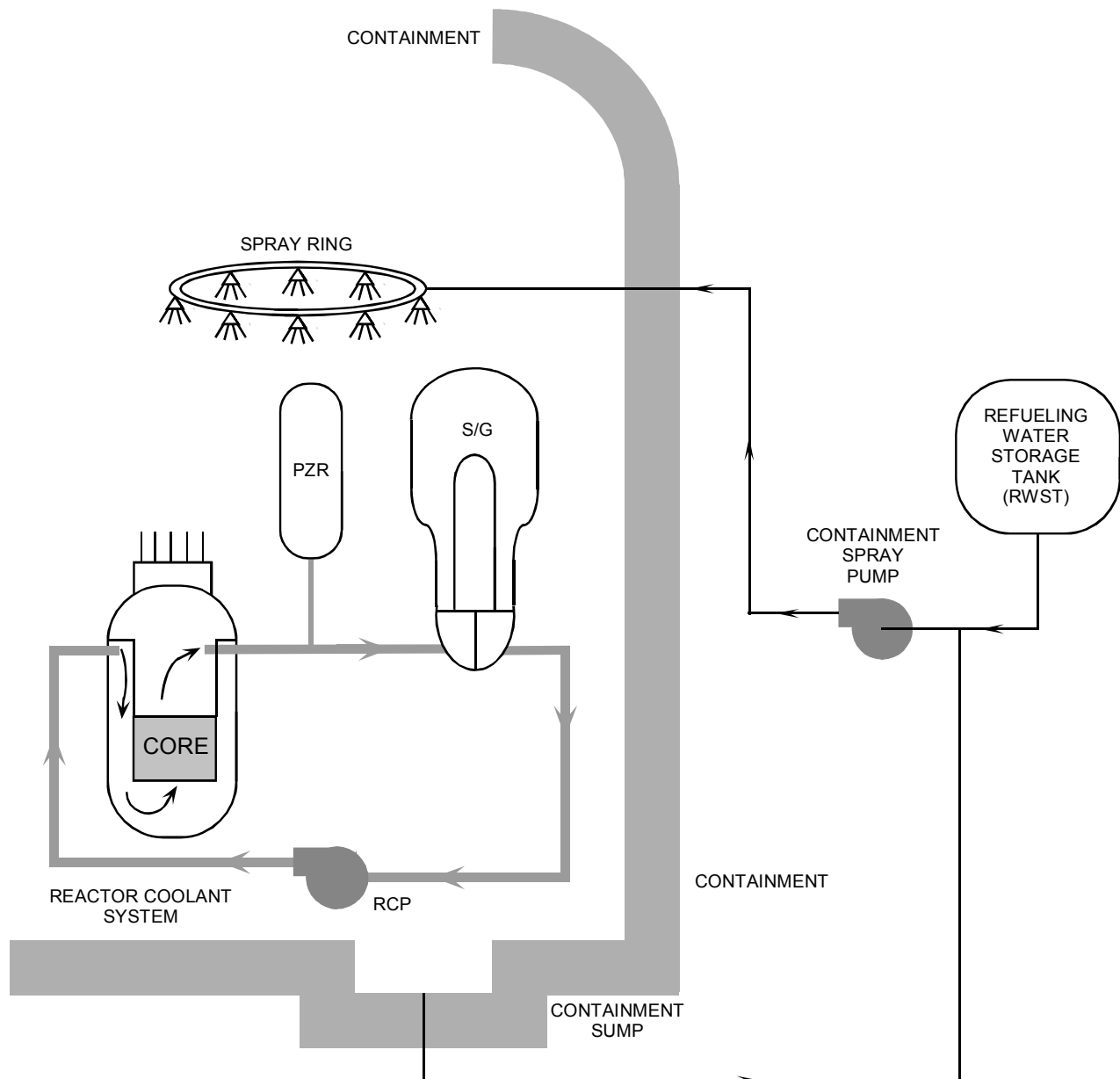

Upon the occurrence of either a secondary break or primary break inside the containment building, the containment atmosphere would become filled with steam. To reduce the pressure and temperature of the building, the containment spray system is automatically started. The containment spray pump will take a suction from the refueling water storage tank and pump the water into spray rings located in the upper part of the containment. The water droplets, being cooler than the steam, will remove heat from the steam, which will cause the steam to condense. This will cause a reduction in the pressure of the building and will also reduce the temperature of the containment atmosphere (similar to the operation of the pressurizer). Like the residual heat removal system, the containment spray system has the capability to take water from the containment sump if the refueling water storage tank goes empty.

Chemical and Volume Control System (W, CE) =
Makeup and Purification System (B&W)

Cold Leg Accumulator (W) =
Core Flood Tanks (B&W) =
Safety Injection Tanks (CE)

Residual Heat Removal System (W) =
Decay Heat Removal System (B&W) =
Shutdown Cooling System (CE)

Auxiliary Feedwater System (W) =
Emergency Feedwater System (B&W, CE)

The three major vendors of pressurized water reactors all have similar systems in their plant designs. For example, all plants are required to have emergency core cooling systems, but not all have an intermediate pressure injection system. One major difference in the designs is that the vendors all call the systems and components by different names. The list above gives some examples of different names even though the function the same.