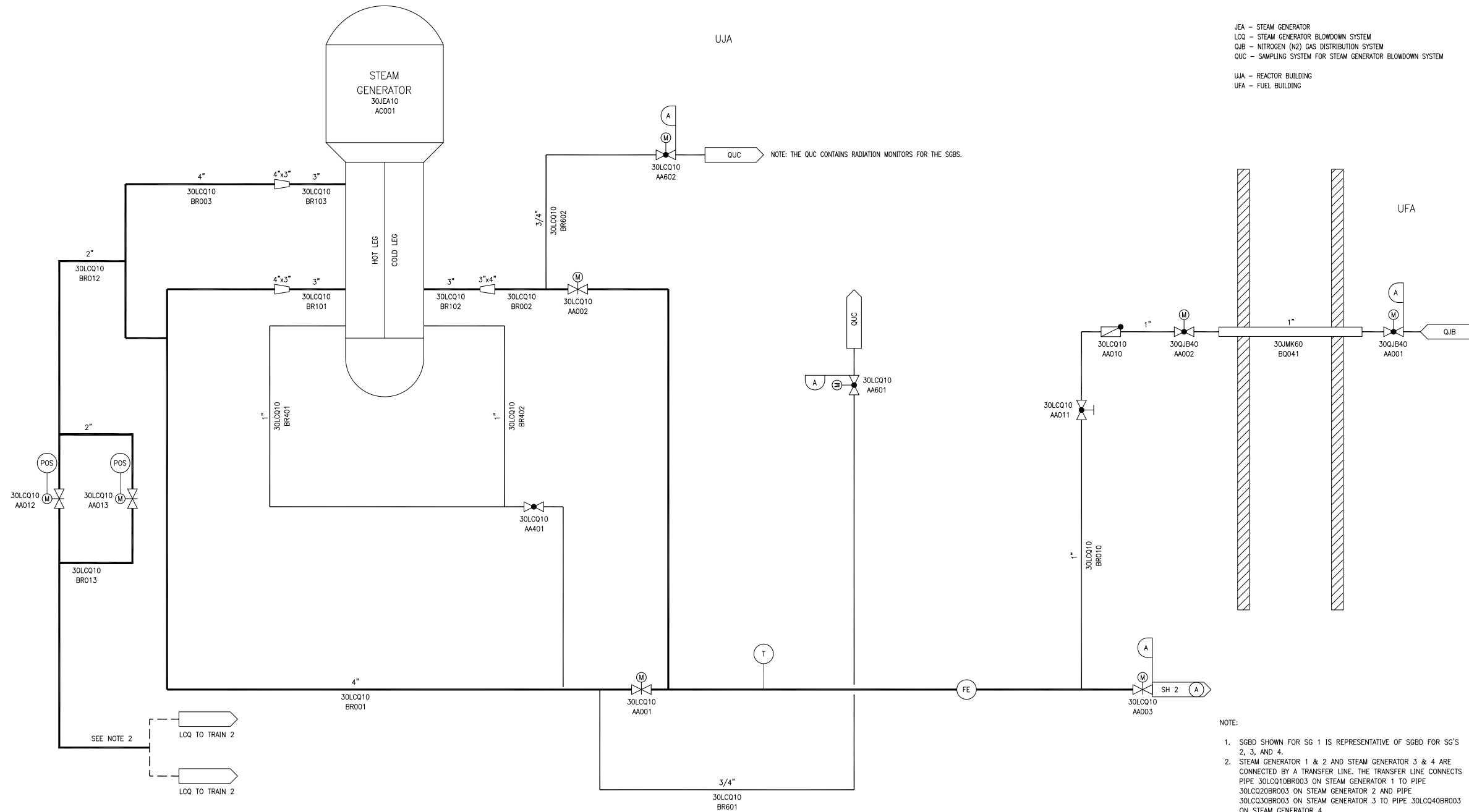

Figure 10.4.8-1—Steam Generator Blowdown System Discharge and Cooling
Sheet 1 of 3



JEA - STEAM GENERATOR
 LCQ - STEAM GENERATOR BLOWDOWN SYSTEM
 QJB - NITROGEN (N2) GAS DISTRIBUTION SYSTEM
 QUC - SAMPLING SYSTEM FOR STEAM GENERATOR BLOWDOWN SYSTEM
 UJA - REACTOR BUILDING
 UFA - FUEL BUILDING

- NOTE:
1. SGBD SHOWN FOR SG 1 IS REPRESENTATIVE OF SGBD FOR SG'S 2, 3, AND 4.
 2. STEAM GENERATOR 1 & 2 AND STEAM GENERATOR 3 & 4 ARE CONNECTED BY A TRANSFER LINE. THE TRANSFER LINE CONNECTS PIPE 30LCQ10BR003 ON STEAM GENERATOR 1 TO PIPE 30LCQ20BR003 ON STEAM GENERATOR 2 AND PIPE 30LCQ30BR003 ON STEAM GENERATOR 3 TO PIPE 30LCQ40BR003 ON STEAM GENERATOR 4.

A	B	I
DESIGN AREA	SSC QUALITY GROUP	SSC SEISMIC CLASS

REV 005
LCQ01T2

Figure 10.4.8-1—Steam Generator Blowdown System Discharge and Cooling
Sheet 2 of 3

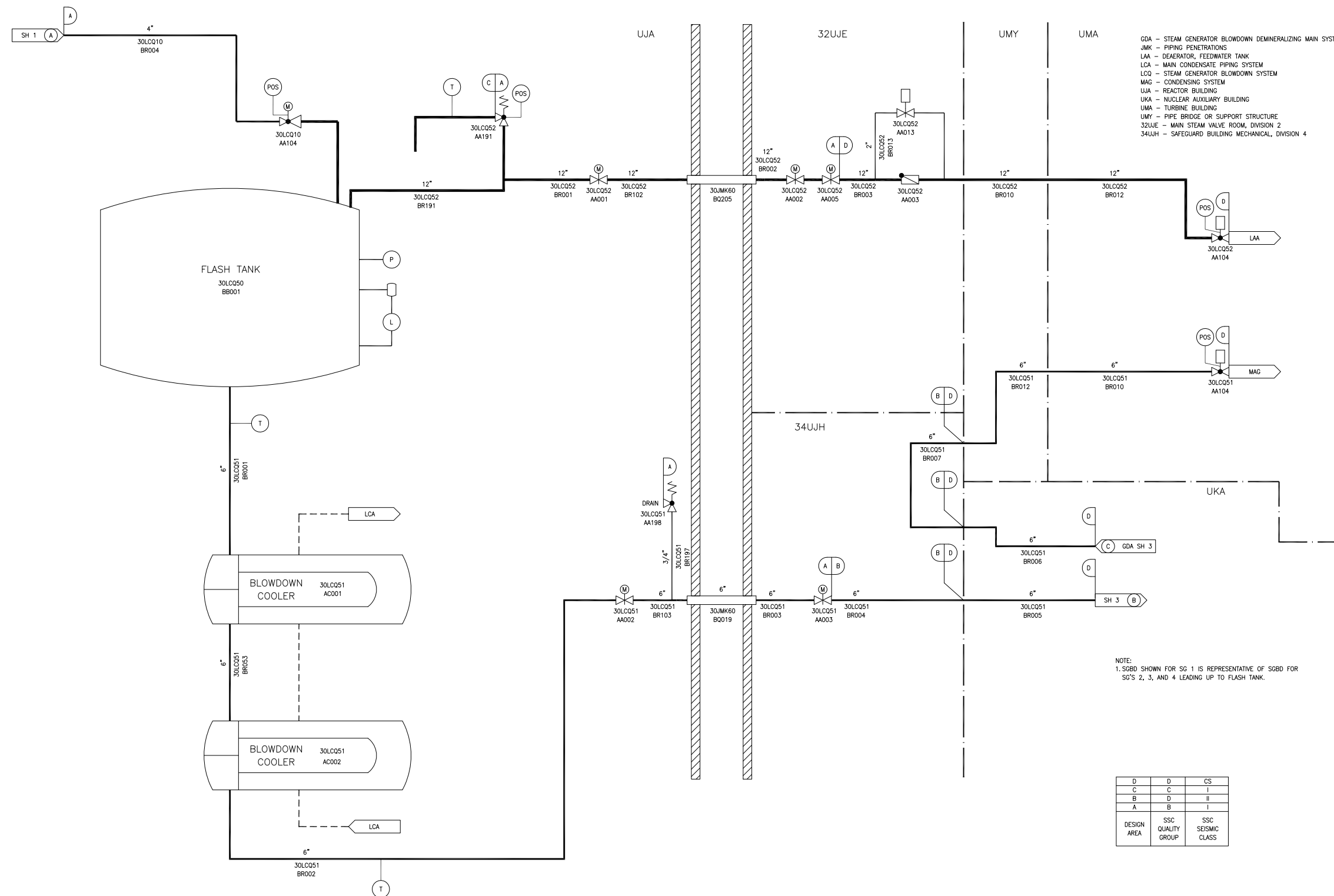

GDA - STEAM GENERATOR BLOWDOWN DEMINERALIZING MAIN SYSTEM
 JMK - PIPING PENETRATIONS
 LAA - DEAERATOR, FEEDWATER TANK
 LCA - MAIN CONDENSATE PIPING SYSTEM
 LCQ - STEAM GENERATOR BLOWDOWN SYSTEM
 MAG - CONDENSING SYSTEM
 UJA - REACTOR BUILDING
 UKA - NUCLEAR AUXILIARY BUILDING
 UMA - TURBINE BUILDING
 UMY - PIPE BRIDGE OR SUPPORT STRUCTURE
 32UJE - MAIN STEAM VALVE ROOM, DIVISION 2
 34UJH - SAFEGUARD BUILDING MECHANICAL, DIVISION 4

NOTE:
 1. SGBD SHOWN FOR SG 1 IS REPRESENTATIVE OF SGBD FOR SG'S 2, 3, AND 4 LEADING UP TO FLASH TANK.

D	D	CS
C	C	I
B	D	II
A	B	I
DESIGN AREA	SSC QUALITY GROUP	SSC SEISMIC CLASS

REV 007
 LCQ02T2

Figure 10.4.8-1—Steam Generator Blowdown System Discharge and Cooling
Sheet 3 of 3

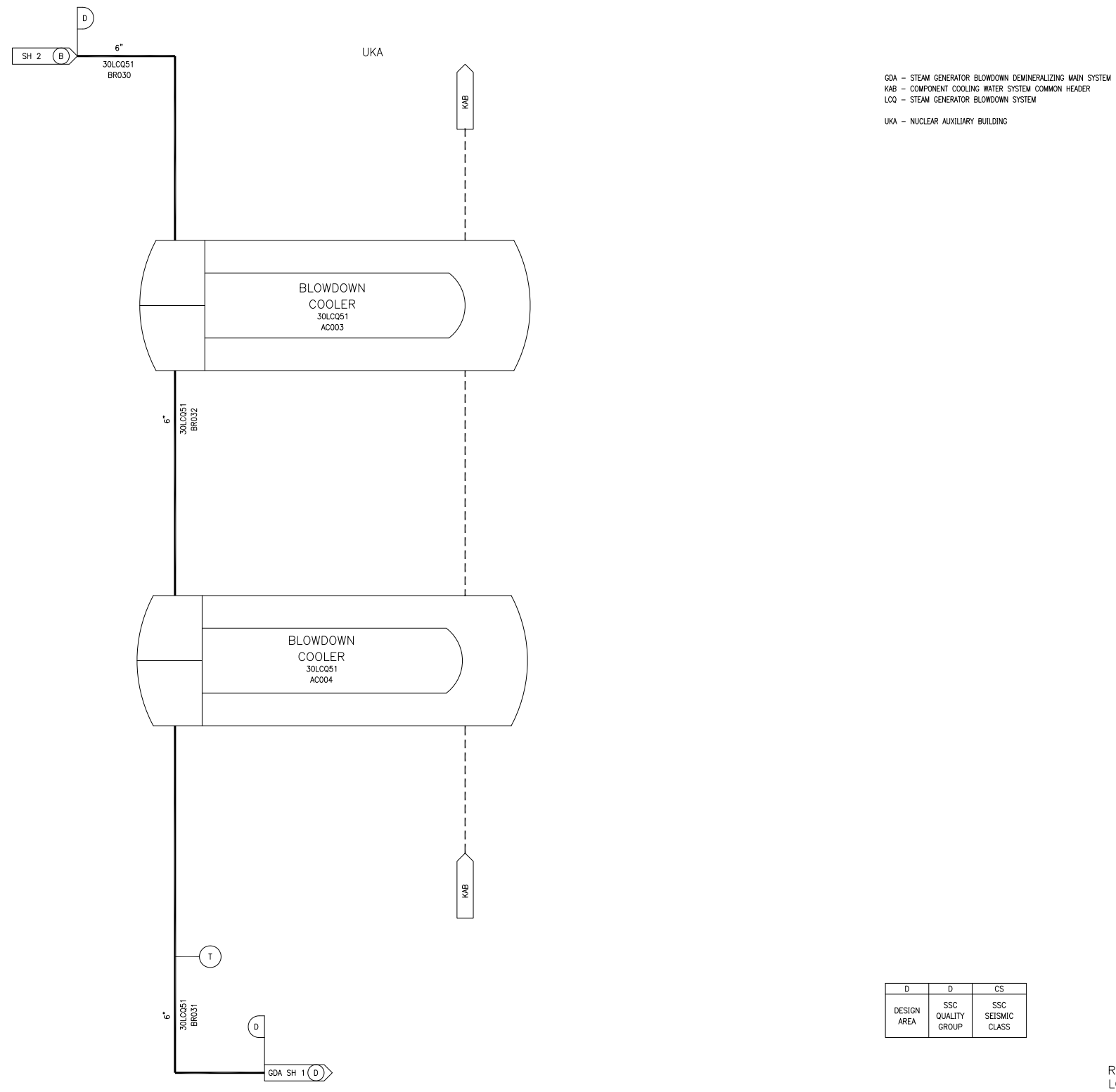
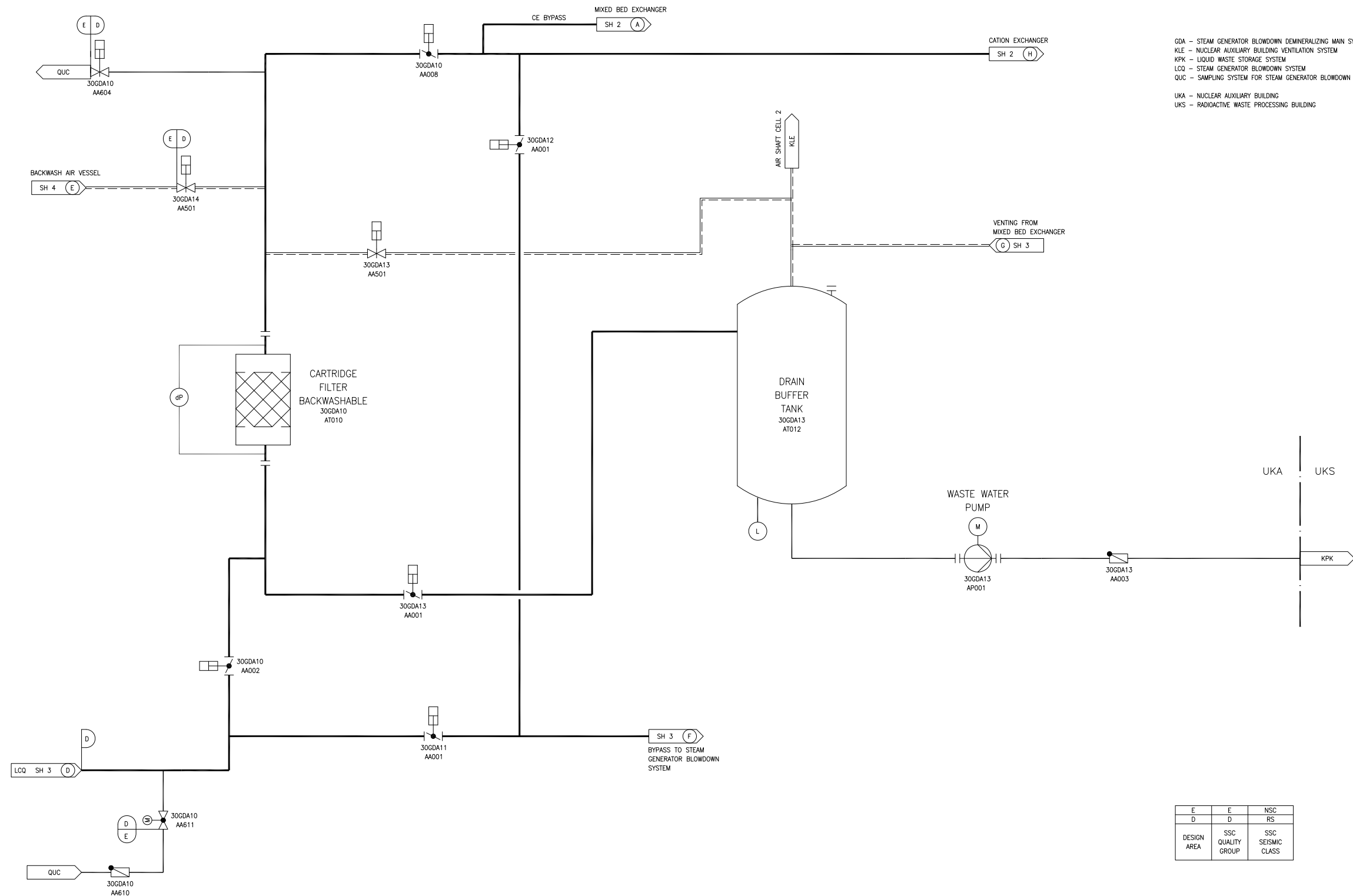

Figure 10.4.8-2—Steam Generator Blowdown Demineralizing System Flow Diagram
Sheet 1 of 4



GDA - STEAM GENERATOR BLOWDOWN DEMINERALIZING MAIN SYSTEM
 KLE - NUCLEAR AUXILIARY BUILDING VENTILATION SYSTEM
 KPK - LIQUID WASTE STORAGE SYSTEM
 LCQ - STEAM GENERATOR BLOWDOWN SYSTEM
 QUC - SAMPLING SYSTEM FOR STEAM GENERATOR BLOWDOWN SYSTEM
 UKA - NUCLEAR AUXILIARY BUILDING
 UKS - RADIOACTIVE WASTE PROCESSING BUILDING

E	E	NSC
D	D	RS
DESIGN AREA	SSC QUALITY GROUP	SSC SEISMIC CLASS

REV 005
GDA01T2

Figure 10.4.8-2—Steam Generator Blowdown Demineralizing System Flow Diagram
Sheet 2 of 4

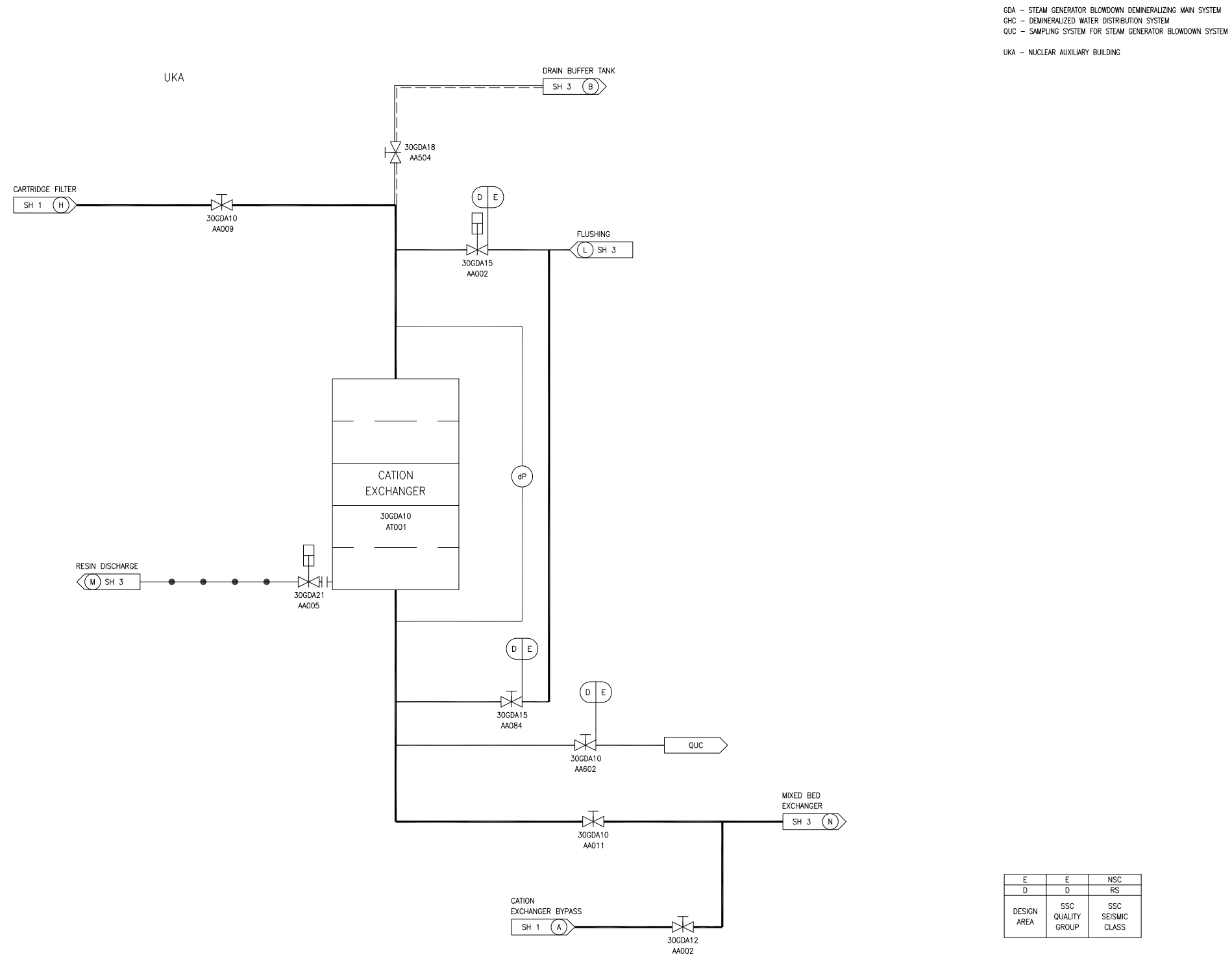

REV 005
GDA02T2

Figure 10.4.8-2—Steam Generator Blowdown Demineralizing System Flow Diagram
Sheet 3 of 4

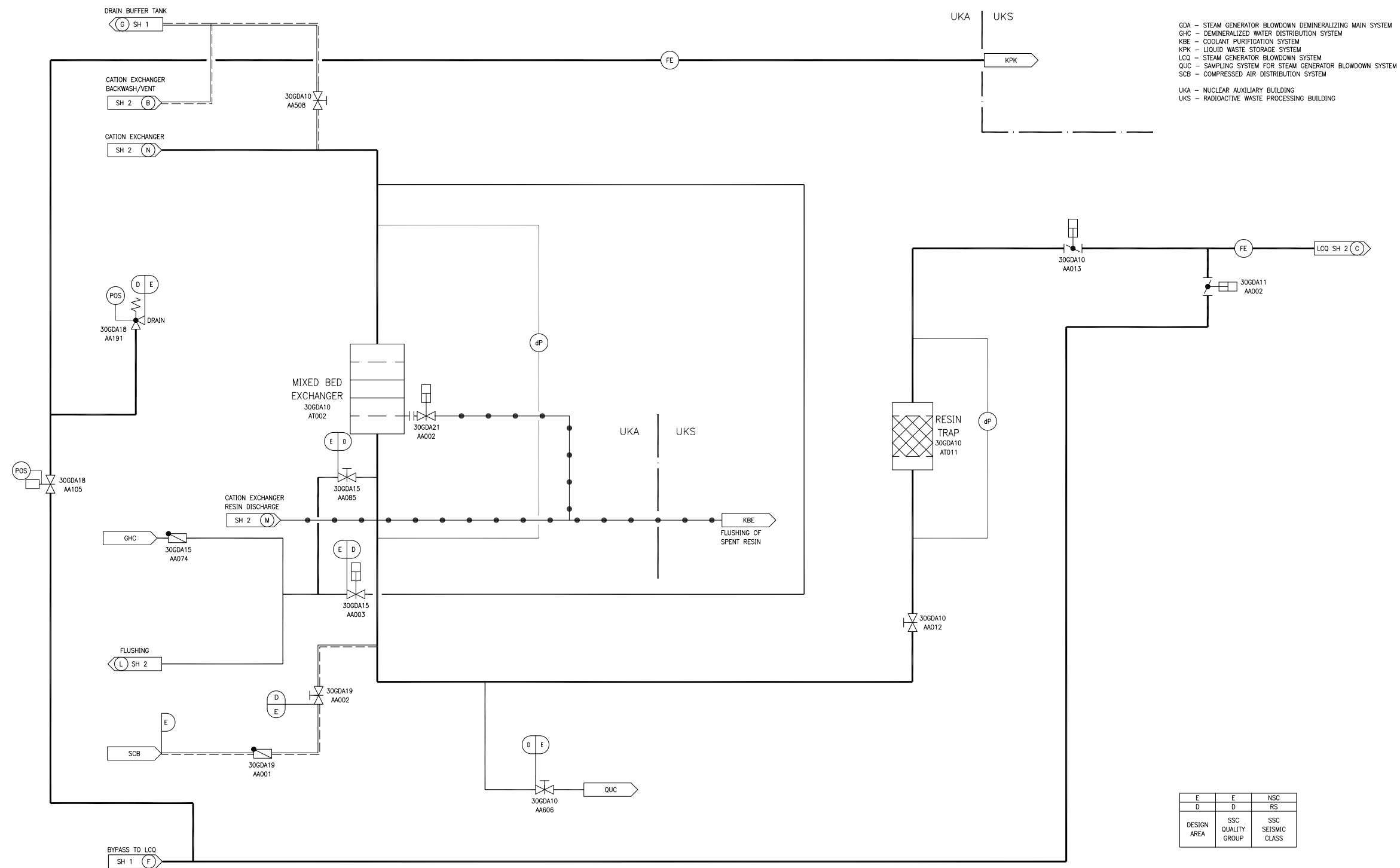

REV 005
GDA03T2

Figure 10.4.8-2—Steam Generator Blowdown Demineralizing System Flow Diagram
Sheet 4 of 4

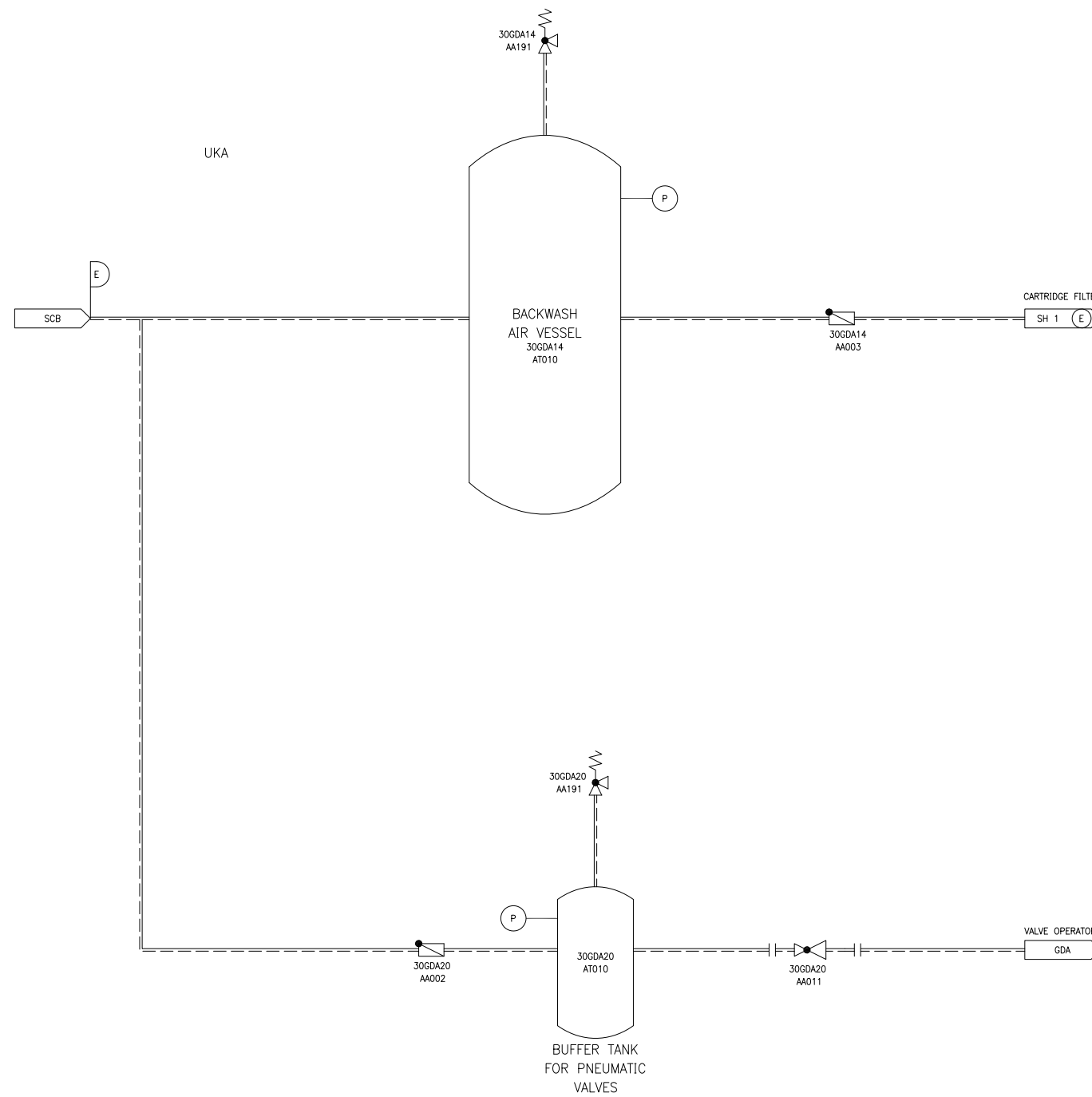

GDA - STEAM GENERATOR BLOWDOWN DEMINERALIZING MAIN SYSTEM
SCB - COMPRESSED AIR DISTRIBUTION SYSTEM
UKA - NUCLEAR AUXILIARY BUILDING

E	E	NSC
DESIGN AREA	SSC QUALITY GROUP	SSC SEISMIC CLASS

REV 005
GDA04T2