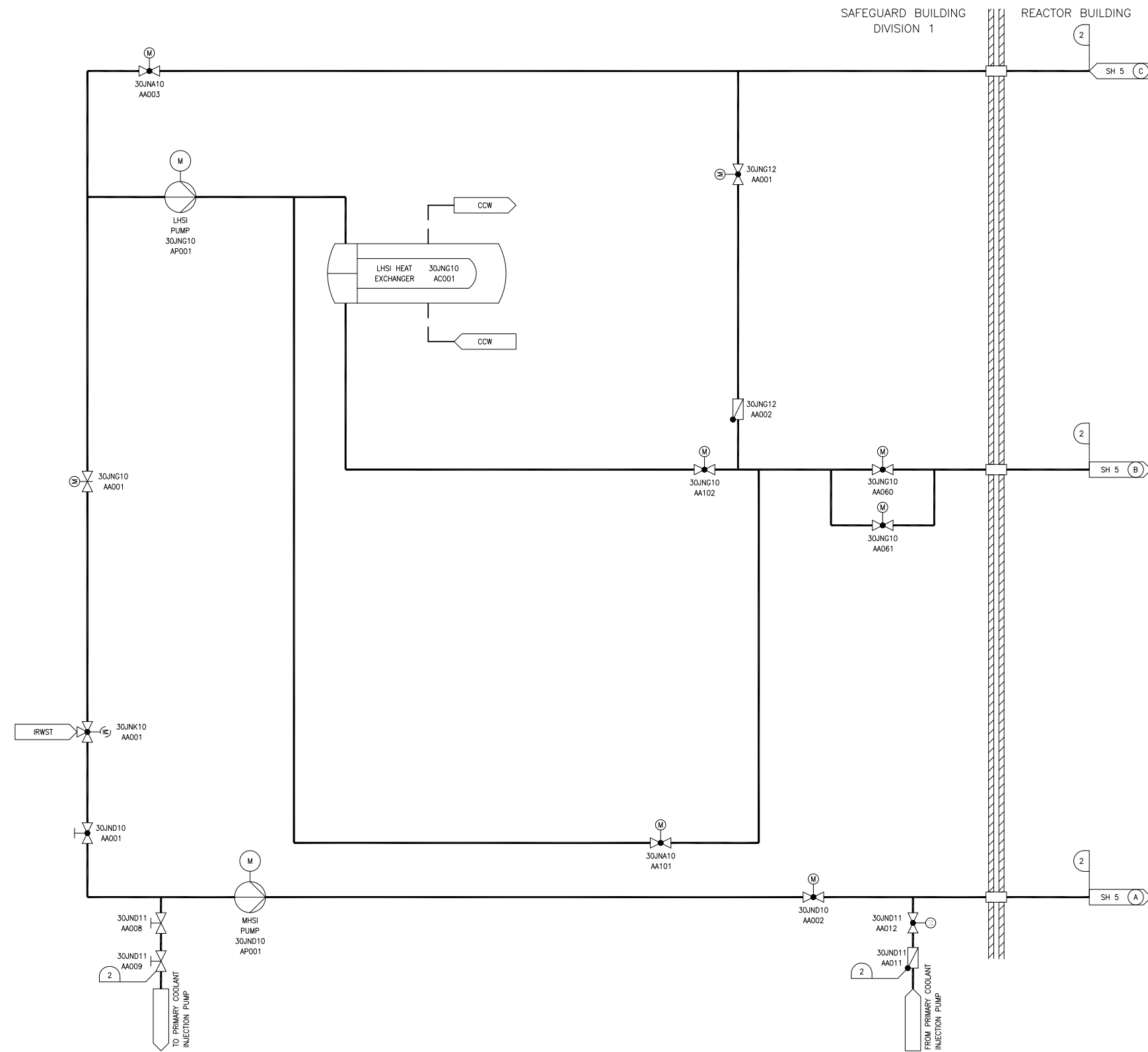

Figure 2.2.3-1—Safety Injection System and Residual Heat Removal System Functional Arrangement
Sheet 1 of 8



2	2	1
DESIGN AREA	ASME III CLASS	SSC SEISMIC CLASS

REV 007
JNX01T1

Figure 2.2.3-1—Safety Injection System and Residual Heat Removal System Functional Arrangement
Sheet 2 of 8

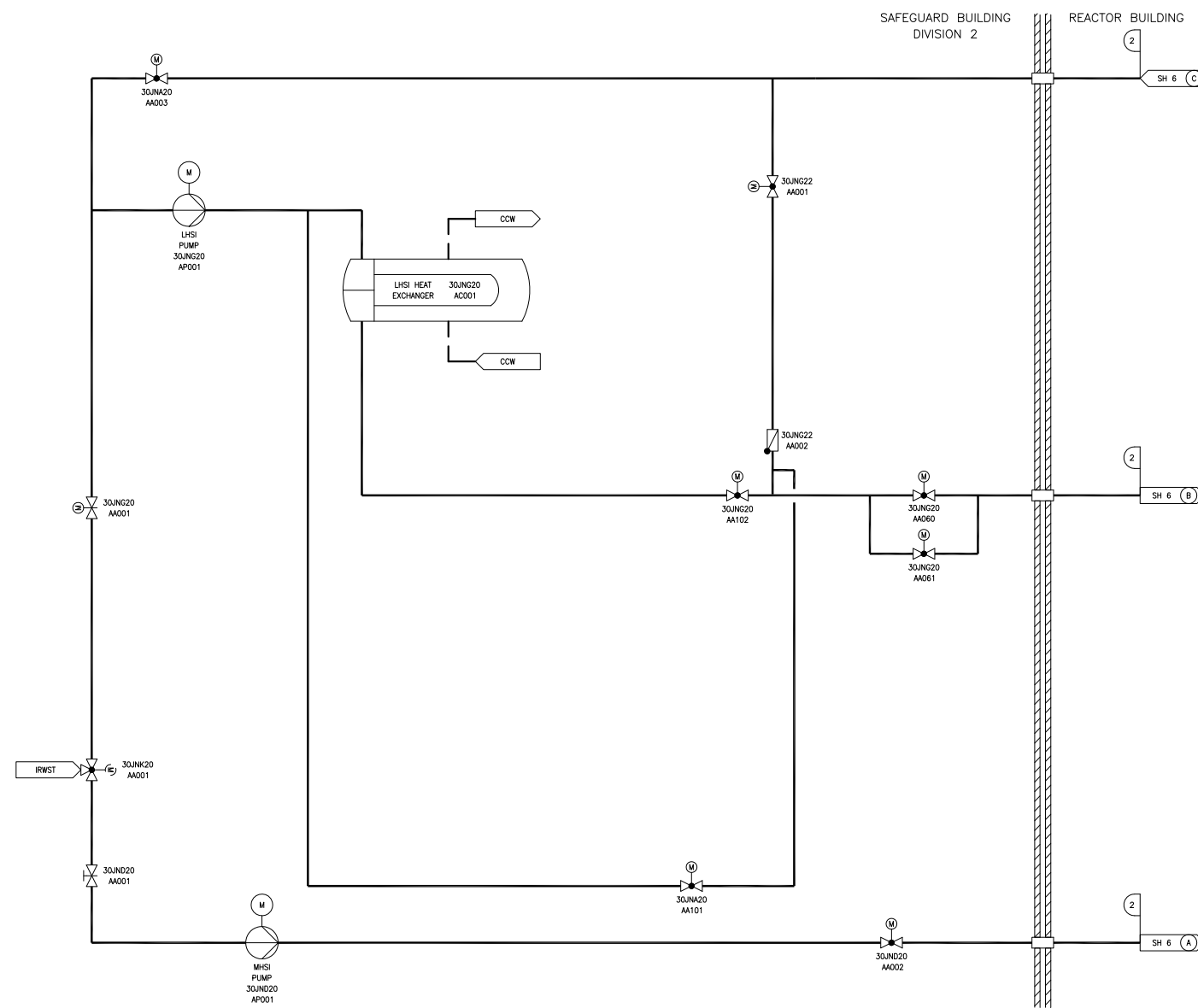

2	2	1
DESIGN AREA	ASME III CLASS	SSC SEISMIC CLASS

REV 005
JNX02T1

Figure 2.2.3-1—Safety Injection System and Residual Heat Removal System Functional Arrangement
Sheet 3 of 8

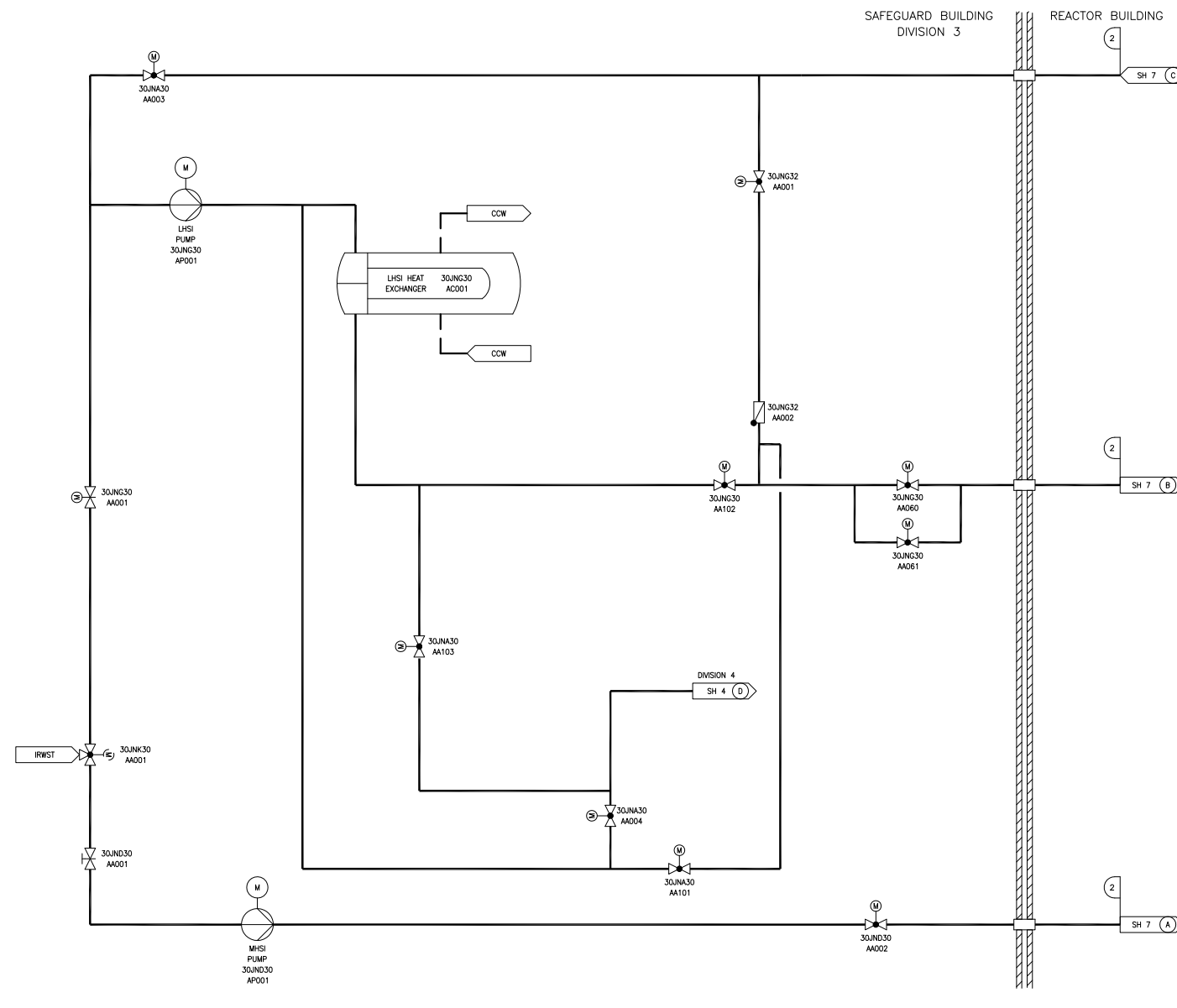

2	2	1
DESIGN AREA	ASME III CLASS	SSC SEISMIC CLASS

REV 005
JNX03T1

Figure 2.2.3-1—Safety Injection System and Residual Heat Removal System Functional Arrangement
Sheet 4 of 8

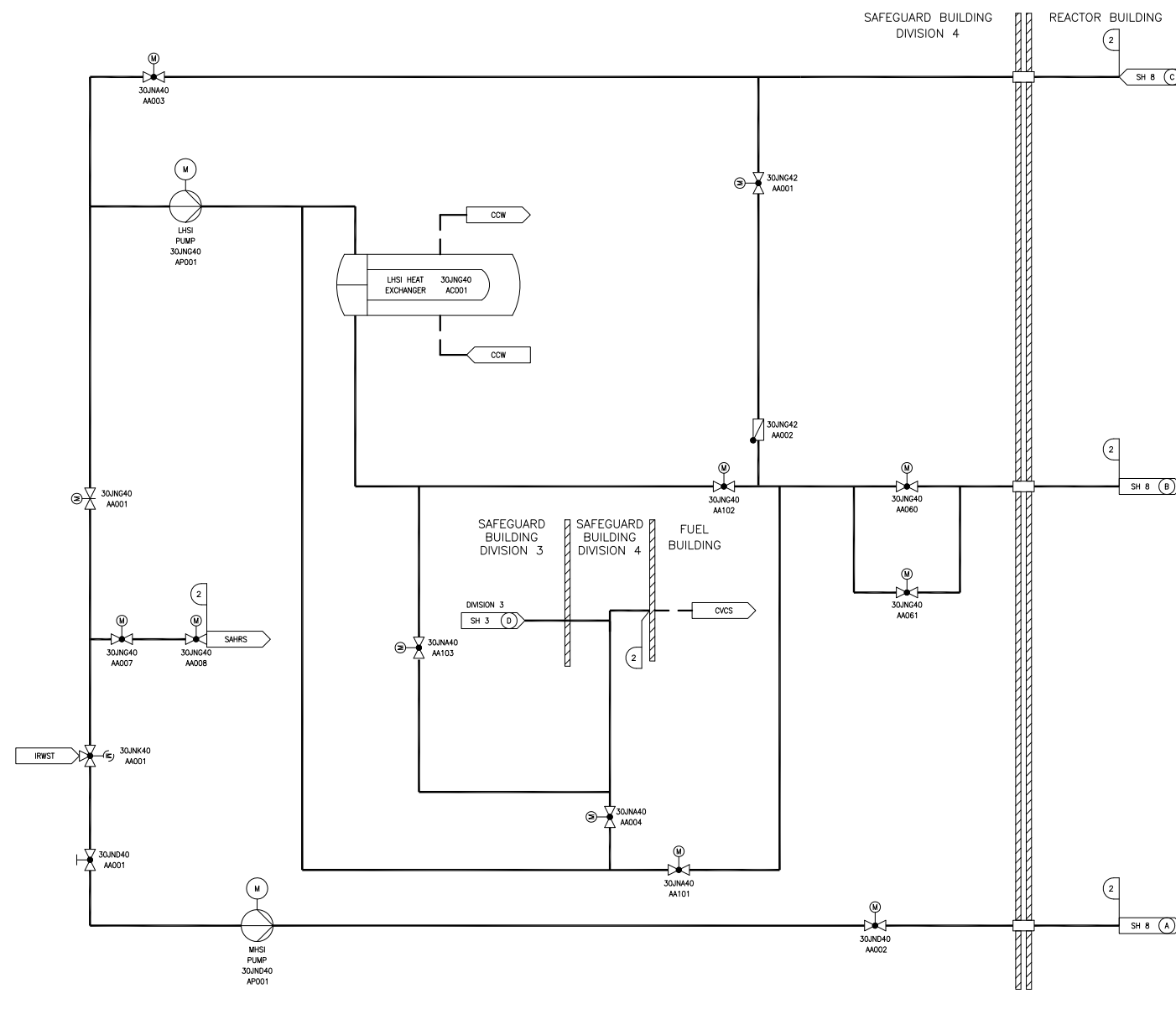

2	2	1
DESIGN AREA	ASME III CLASS	SSC SEISMIC CLASS

REV 005
JNX04T1

Figure 2.2.3-1—Safety Injection System and Residual Heat Removal System Functional Arrangement
Sheet 5 of 8

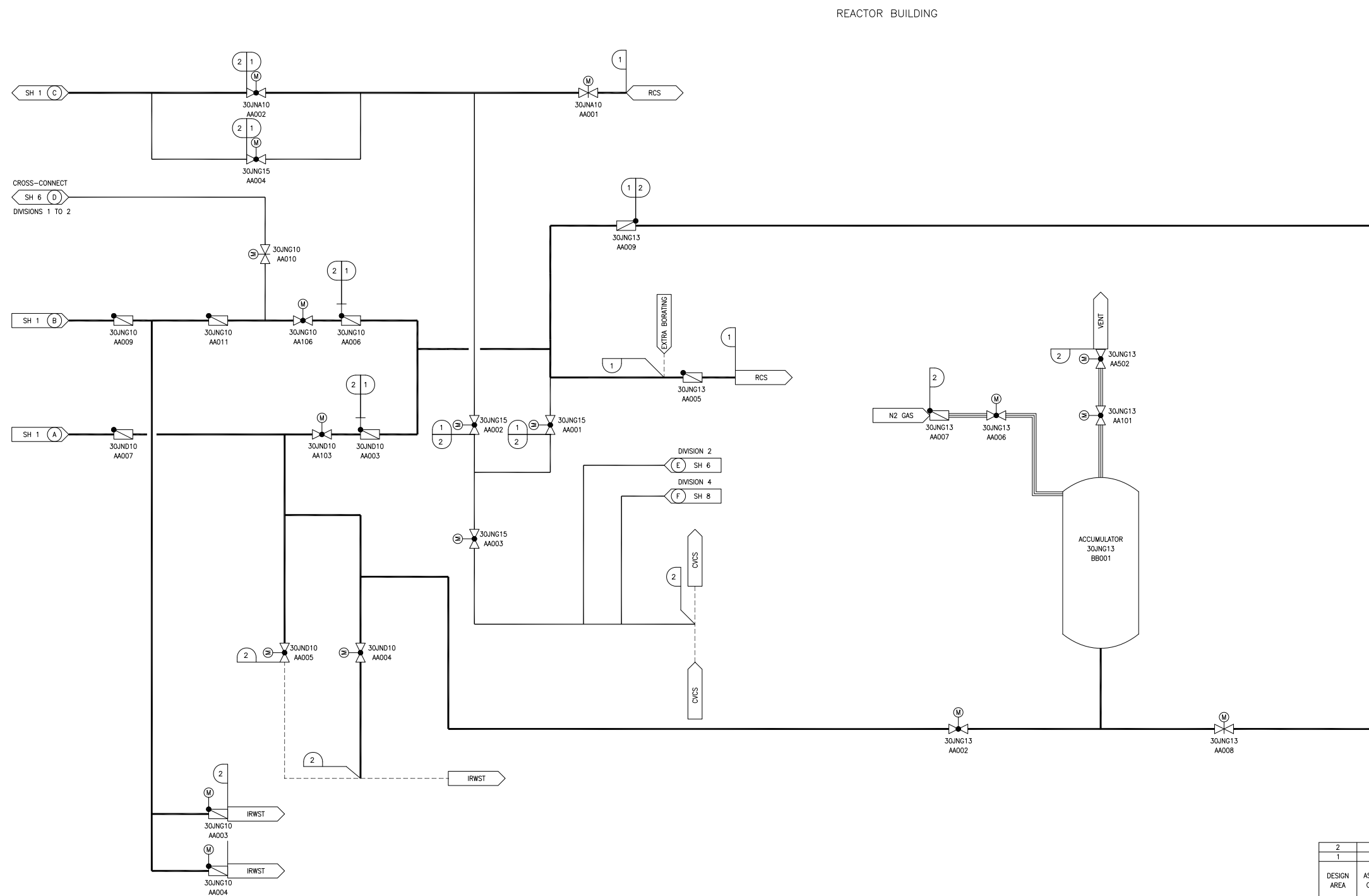

2	2	I
1	1	I
DESIGN AREA	ASME III CLASS	SSC SEISMIC CLASS

REV 003
JNX05T1

Figure 2.2.3-1—Safety Injection System and Residual Heat Removal System Functional Arrangement
Sheet 6 of 8

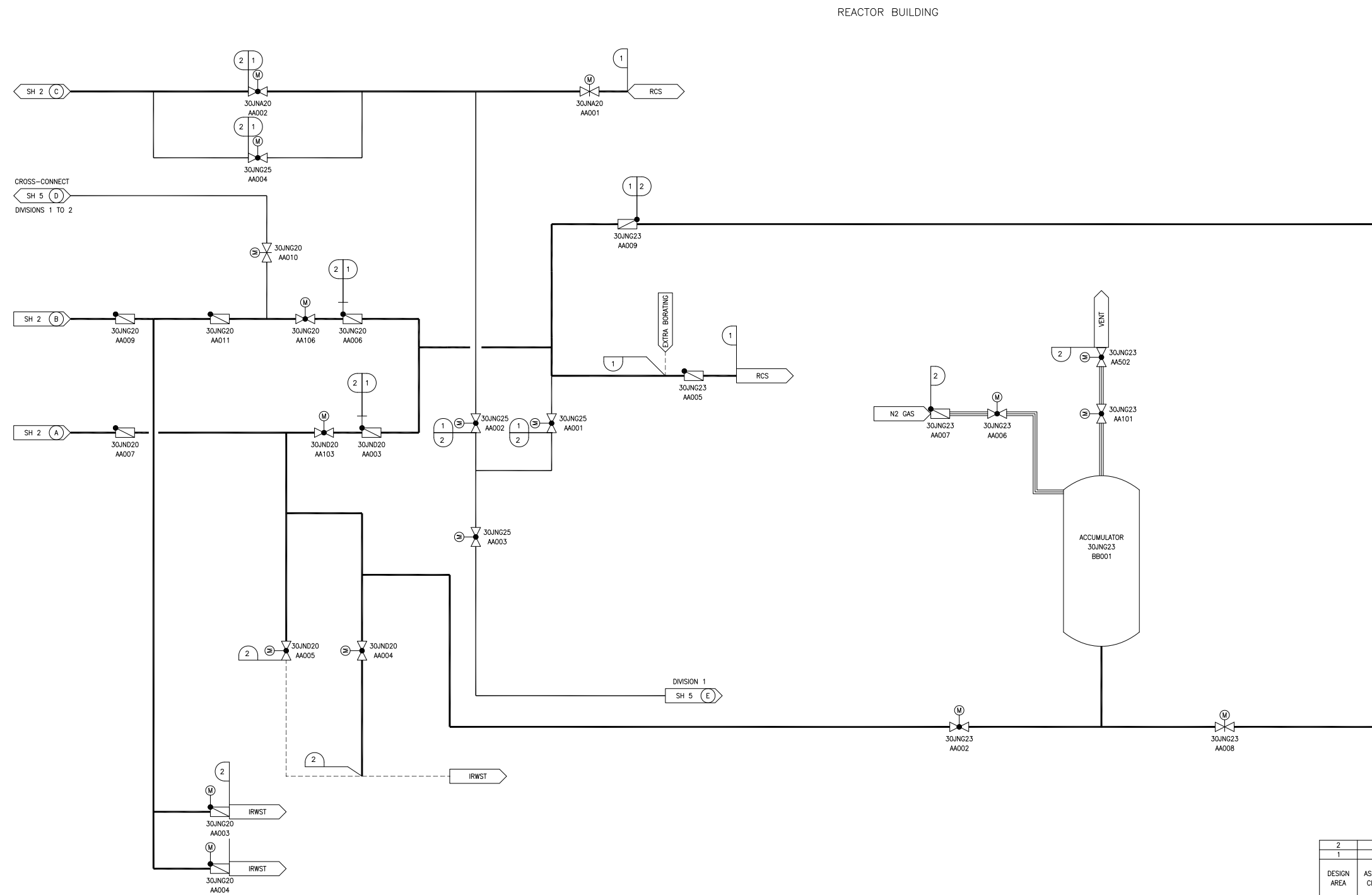

2	2	1
1	1	1
DESIGN AREA	ASME III CLASS	SSC SEISMIC CLASS

REV 003
JNX06T1

Figure 2.2.3-1—Safety Injection System and Residual Heat Removal System Functional Arrangement
Sheet 7 of 8

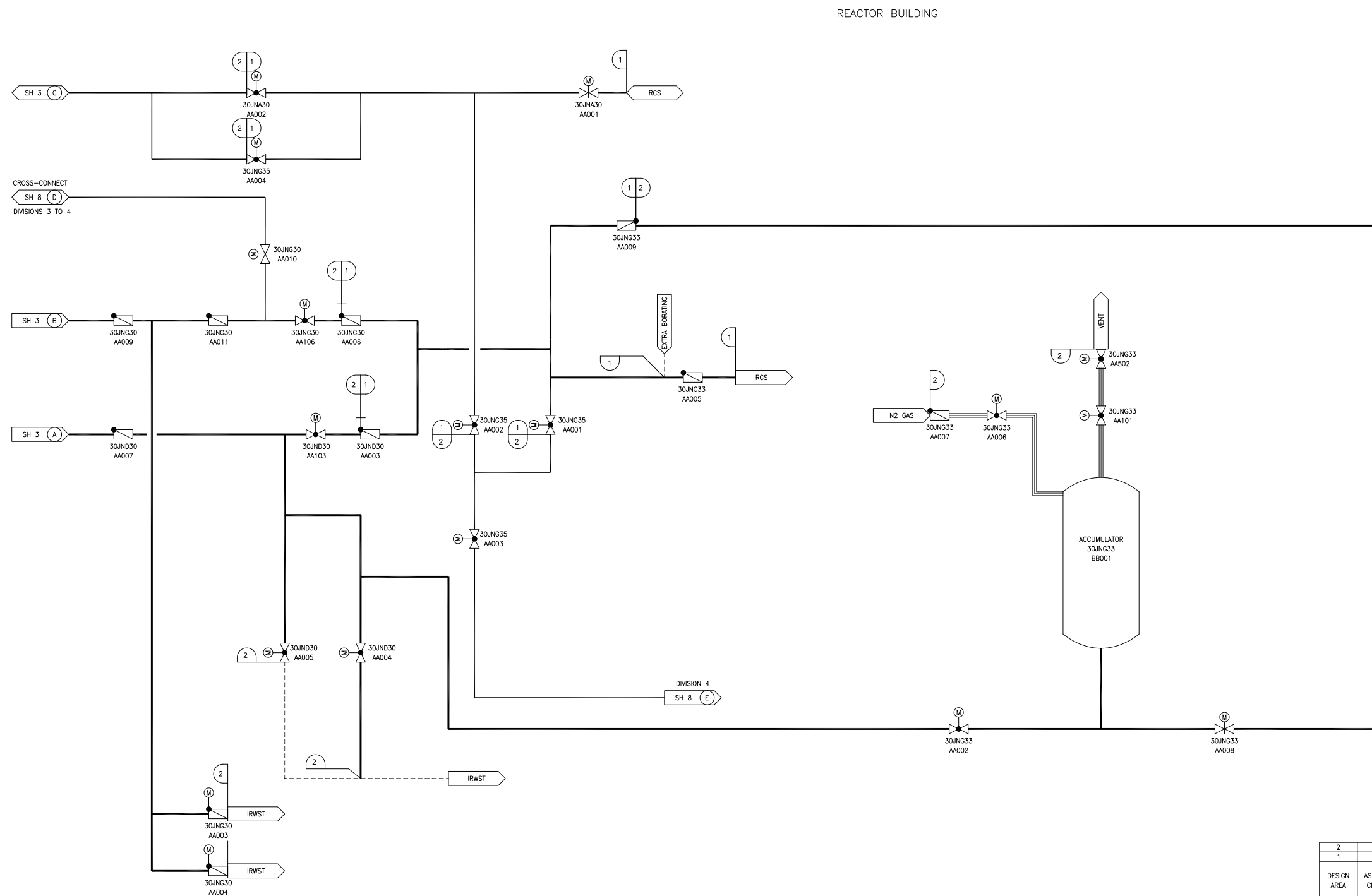

2	2	1
1	1	1
DESIGN AREA	ASME III CLASS	SSC SEISMIC CLASS

REV 003
JNX07T1

Figure 2.2.3-1—Safety Injection System and Residual Heat Removal System Functional Arrangement
Sheet 8 of 8

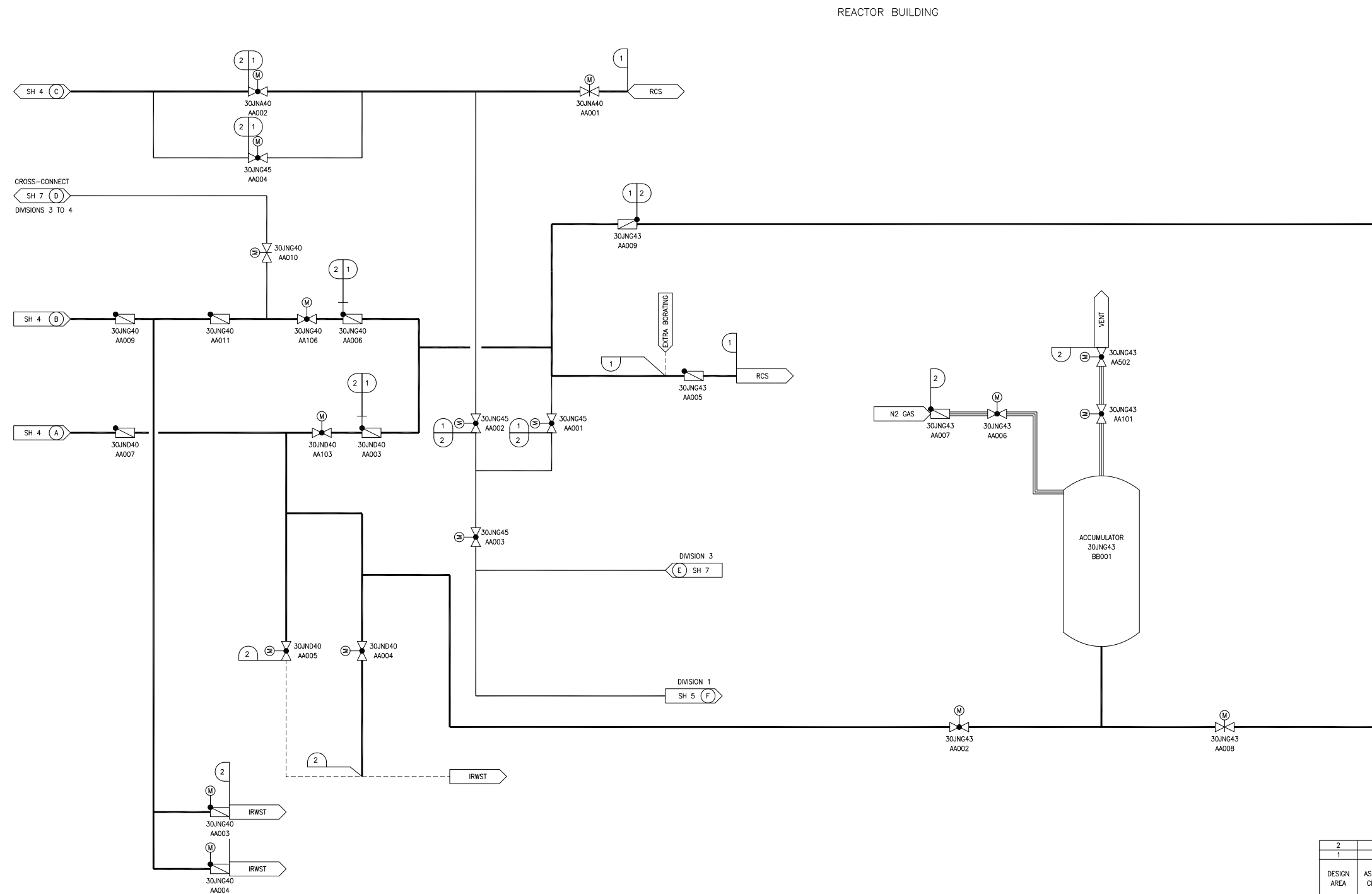

2	2	1
1	1	1
DESIGN AREA	ASME III CLASS	SSC SEISMIC CLASS

REV 003
JNX08T1