

UFSAR Table of Contents

Chapter 1 — Introduction and General Description of the Plant

Chapter 2 — Site Characteristics

Chapter 3 — Design of Structures, Components, Equipment and Systems

Chapter 4 — Reactor

Chapter 5 — Reactor Coolant System and Connected Systems

Chapter 6 — Engineered Safety Features

Chapter 7 — Instrumentation and Controls

Chapter 8 — Electric Power

Chapter 9 — Auxiliary Systems

Chapter 10 — Steam and Power Conversion

Chapter 11 — Radioactive Waste Management

Chapter 12 — Radiation Protection

Chapter 13 — Conduct of Operation

Chapter 14 — Initial Test Program

Chapter 15 — Accident Analyses

Chapter 16 — Technical Specifications

Chapter 17 — Quality Assurance

Chapter 18 — Human Factors Engineering

Chapter 19 — Probabilistic Risk Assessment

UFSAR Formatting Legend





Color	Description
	Original Westinghouse AP1000 DCD Revision 19 content
	Departures from AP1000 DCD Revision 19 content
	Standard FSAR content
	Site-specific FSAR content
	Linked cross-references (chapters, appendices, sections, subsections, tables, figures, and references)

TABLE OF CONTENTS

<u>Section</u>	<u>Title</u>	<u>Page</u>
CHAPTER 11	RADIOACTIVE WASTE MANAGEMENT	11.1-1
11.1	Source Terms.....	11.1-1
11.1.1	Design Basis Reactor Coolant Activity	11.1-1
11.1.1.1	Fission Products	11.1-1
11.1.1.2	Corrosion Products	11.1-3
11.1.1.3	Tritium	11.1-3
11.1.1.4	Nitrogen-16	11.1-3
11.1.2	Design Basis Secondary Coolant Activity.....	11.1-3
11.1.3	Realistic Reactor Coolant and Secondary Coolant Activity	11.1-4
11.1.4	Core Source Term	11.1-4
11.1.5	Process Leakage Sources.....	11.1-4
11.1.6	Combined License Information.....	11.1-4
11.1.7	References	11.1-4
11.2	Liquid Waste Management Systems.....	11.2-1
11.2.1	Design Basis.....	11.2-1
11.2.1.1	Safety Design Basis.....	11.2-1
11.2.1.2	Power Generation Design Basis	11.2-1
11.2.1.3	Compliance with 10 CFR 20.1406	11.2-6
11.2.2	System Description.....	11.2-6
11.2.2.1	Waste Input Streams	11.2-7
11.2.2.2	Other Operations	11.2-10
11.2.2.3	Component Description	11.2-10
11.2.2.4	Instrumentation Design.....	11.2-13
11.2.2.5	System Operation and Performance.....	11.2-13
11.2.3	Radioactive Releases	11.2-17
11.2.3.1	Discharge Requirements	11.2-17
11.2.3.2	Estimated Annual Releases.....	11.2-17
11.2.3.3	Dilution Factor.....	11.2-17
11.2.3.4	Release Concentrations.....	11.2-18
11.2.3.5	Estimated Doses.....	11.2-18
11.2.3.6	Quality Assurance.....	11.2-20
11.2.4	Preoperational Testing	11.2-20
11.2.4.1	Sump Level Instrument Testing	11.2-20
11.2.4.2	Discharge Control/Isolation Valve Testing	11.2-21
11.2.4.3	Preoperational Inspection	11.2-21
11.2.5	Combined License Information.....	11.2-21
11.2.5.1	Liquid Radwaste Processing by Mobile Equipment	11.2-21
11.2.5.2	Cost Benefit Analysis of Population Doses.....	11.2-21
11.2.5.3	Identification of Ion Exchange and Adsorbent Media	11.2-21
11.2.5.4	Dilution and Control of Boric Acid Discharge	11.2-21
11.2.6	References	11.2-21
11.3	Gaseous Waste Management System.....	11.3-1
11.3.1	Design Basis.....	11.3-1
11.3.1.1	Safety Design Basis.....	11.3-1
11.3.1.2	Power Generation Design Basis	11.3-1
11.3.1.3	Compliance with 10 CFR 20.1406	11.3-3
11.3.2	System Description.....	11.3-4

TABLE OF CONTENTS (CONTINUED)

<u>Section</u>	<u>Title</u>	<u>Page</u>
	11.3.2.1 General Description	11.3-4
	11.3.2.2 System Operation	11.3-5
	11.3.2.3 Component Description	11.3-6
11.3.3	Radioactive Releases	11.3-7
	11.3.3.1 Discharge Requirements	11.3-8
	11.3.3.2 Estimated Annual Releases	11.3-8
	11.3.3.3 Release Points	11.3-8
	11.3.3.4 Estimated Doses	11.3-8
	11.3.3.5 Maximum Release Concentrations	11.3-11
	11.3.3.6 Quality Assurance	11.3-11
11.3.4	Inspection and Testing Requirements	11.3-11
	11.3.4.1 Preoperational Testing	11.3-11
	11.3.4.2 Preoperational Inspection	11.3-11
11.3.5	Combined License Information	11.3-11
	11.3.5.1 Cost Benefit Analysis of Population Doses	11.3-11
	11.3.5.2 Identification of Adsorbent Media	11.3-12
11.3.6	References	11.3-12
11.4	Solid Waste Management	11.4-1
	11.4.1 Design Basis	11.4-1
	11.4.1.1 Safety Design Basis	11.4-1
	11.4.1.2 Power Generation Design Basis	11.4-1
	11.4.1.3 Functional Design Basis	11.4-1
	11.4.1.4 Compliance with 10 CFR 20.1406	11.4-3
	11.4.2 System Description	11.4-3
	11.4.2.1 General Description	11.4-3
	11.4.2.2 Component Description	11.4-6
	11.4.2.3 System Operation	11.4-7
	11.4.2.4 Waste Processing and Disposal Alternatives	11.4-10
	11.4.2.5 Facilities	11.4-11
11.4.3	System Safety Evaluation	11.4-12
11.4.4	Tests and Inspections	11.4-12
11.4.5	Quality Assurance	11.4-12
11.4.6	Combined License Information for Solid Waste Management System Process Control Program	11.4-12
	11.4.6.1 Procedures	11.4-13
	11.4.6.2 Third Party Vendors	11.4-13
	11.4.6.3 Long Term On-Site Storage Facility	11.4-13
11.4.7	References	11.4-15
11.5	Radiation Monitoring	11.5-1
	11.5.1 Design Basis	11.5-1
	11.5.1.1 Safety Design Basis	11.5-1
	11.5.1.2 Power Generation Design Basis	11.5-2
	11.5.2 System Description	11.5-2
	11.5.2.1 Radiation Monitoring System	11.5-2
	11.5.2.2 Monitor Functional Description	11.5-3
	11.5.2.3 Monitor Descriptions	11.5-3
	11.5.2.4 Inservice Inspection, Calibration, and Maintenance	11.5-11

TABLE OF CONTENTS (CONTINUED)

<u>Section</u>	<u>Title</u>	<u>Page</u>
11.5.3	Effluent Monitoring and Sampling.....	11.5-11
11.5.4	Process and Airborne Monitoring and Sampling	11.5-12
	11.5.4.1 Effluent Sampling.....	11.5-12
	11.5.4.2 Representative Sampling.....	11.5-12
11.5.5	Post-Accident Radiation Monitoring	11.5-13
11.5.6	Area Radiation Monitors	11.5-14
	11.5.6.1 Design Objectives	11.5-14
	11.5.6.2 Post-Accident Area Monitors	11.5-15
	11.5.6.3 Normal Range Area Monitors	11.5-16
	11.5.6.4 Fuel Handling Area Criticality Monitors.....	11.5-16
	11.5.6.5 Quality Assurance.....	11.5-16
11.5.7	Preoperational Testing	11.5-17
11.5.8	Combined License Information.....	11.5-17
11.5.9	References	11.5-18

LIST OF TABLES

<u>Table Number</u>	<u>Title</u>	<u>Page</u>
11.1-1	Parameters Used in the Calculation of Design Basis Fission Product Activities	11.1-5
11.1-2	Design Basis Reactor Coolant Activity	11.1-7
11.1-3	Tritium Sources	11.1-8
11.1-4	Parameters Used to Calculate Secondary Coolant Activity	11.1-9
11.1-5	Design Basis Steam Generator Secondary Side Liquid Activity	11.1-10
11.1-6	Design Basis Steam Generator Secondary Side Steam Activity	11.1-11
11.1-7	Parameters Used to Describe Realistic Sources	11.1-12
11.1-8	Realistic Source Terms	11.1-13
11.2-1	Liquid Inputs and Disposition	11.2-23
11.2-2	Component Data – Liquid Radwaste System.....	11.2-25
11.2-3	Summary of Tank Level Indication, Level Annunciators, and Overflows	11.2-32
11.2-4	Tank Surge Capacity	11.2-33
11.2-5	Decontamination Factors	11.2-34
11.2-6	Input Parameters for the GALE Computer Code.....	11.2-35
11.2-7	Releases to Discharge Canal (Ci/Yr) Calculated by GALE Code	11.2-38
11.2-8	Comparison of Annual Average Liquid Release Concentrations with 10 CFR 20 for Expected Releases Effluent Concentration Limits	11.2-40
11.2-9	Comparison of Annual Average Liquid Release Concentrations with 10 CFR 20 Effluent Concentration Limits for Releases with Maximum Defined Fuel Defects.....	11.2-42
11.2-201	Liquid Pathway Parameters	11.2-44
11.2-202	Liquid Pathway Consumption Factors for Maximally Exposed Individual ...	11.2-44
11.2-203	Release of Activities in Liquid Effluent	11.2-45
11.2-204	Liquid Pathway Doses for Maximally Exposed Individuals.....	11.2-48
11.2-205	Comparison of Maximally Exposed Individual Doses with 10 CFR 50, Appendix I Criteria.....	11.2-48
11.2-206	Comparison of Maximally Exposed Individual Doses with 40 CFR 190 Criteria.....	11.2-49
11.2-207	Collective Total Body Doses Within 50 Miles	11.2-49
11.3-1	Gaseous Radwaste System Parameters	11.3-13
11.3-2	Component Data (Nominal) — Gaseous Radwaste System.....	11.3-14
11.3-3	Expected Annual Average Release of Airborne Radionuclides as Determined by the PWR-GALE Code, Revision 1	11.3-16
11.3-4	Comparison of Calculated Offsite Airborne Concentrations with 10 CFR 20 Limits	11.3-19
11.3-201	Gaseous Pathway Parameters.....	11.3-21
11.3-202	Gaseous Pathway Consumption Factors for Maximally Exposed Individual	11.3-21
11.3-203	Release of Activities in Gaseous Effluent.....	11.3-22
11.3-204	Gaseous Pathway Receptor Locations	11.3-24
11.3-205	Gaseous Pathway Doses for Maximally Exposed Individuals.....	11.3-25
11.3-206	Comparison of Maximally Exposed Individual Doses with 10 CFR 50, Appendix I Criteria.....	11.3-26
11.3-207	Comparison of Maximally Exposed Individual Doses with 40 CFR 190 Criteria.....	11.3-26
11.3-208	Collective Total Body Doses Within 50 Miles	11.3-27
11.4-1	Estimated Solid Radwaste Volumes	11.4-17

LIST OF TABLES (CONTINUED)

<u>Table Number</u>	<u>Title</u>	<u>Page</u>
11.4-2	Expected Annual Curie Content of Primary Influent.....	11.4-18
11.4-3	Maximum Annual Curie Content of Primary Influent.....	11.4-20
11.4-4	Expected Annual Curie Content of Shipped Primary Wastes.....	11.4-22
11.4-5	Maximum Annual Curie Content of Shipped Primary Wastes.....	11.4-24
11.4-6	Expected Annual Curie Content of Secondary Waste as Generated.....	11.4-26
11.4-7	Maximum Annual Curie Content of Secondary Waste as Generated.....	11.4-28
11.4-8	Expected Annual Curie Content of Shipped Secondary Wastes.....	11.4-30
11.4-9	Maximum Annual Curie Content of Shipped Secondary Wastes.....	11.4-32
11.4-10	Component Data — Solid Waste Management System (Nominal).....	11.4-34
11.5-1	Radiation Monitor Detector Parameters.....	11.5-19
11.5-2	Area Radiation Monitor Detector Parameters.....	11.5-21
11.5-201	Minimum Sampling Frequency.....	11.5-22
11.5-202	Minimum Sensitivities.....	11.5-24

LIST OF FIGURES

Figure Number	Title	Page
11.2-1	Liquid Radwaste System Simplified Piping and Instrumentation Diagram..	11.2-50
11.2-2	(Sheet 1 of 8) Liquid Radwaste System Piping and Instrumentation Diagram.....	11.2-51
11.2-2	(Sheet 2 of 8) Liquid Radwaste System Piping and Instrumentation Diagram.....	11.2-52
11.2-2	(Sheet 3 of 8) Liquid Radwaste System Piping and Instrumentation Diagram.....	11.2-53
11.2-2	(Sheet 4 of 8) Liquid Radwaste System Piping and Instrumentation Diagram.....	11.2-54
11.2-2	(Sheet 5 of 8) Liquid Radwaste System Piping and Instrumentation Diagram.....	11.2-55
11.2-2	(Sheet 6 of 8) Liquid Radwaste System Piping and Instrumentation Diagram.....	11.2-56
11.2-2	(Sheet 7 of 8) Liquid Radwaste System Piping and Instrumentation Diagram.....	11.2-57
11.2-2	(Sheet 8 of 8) Liquid Radwaste System Piping and Instrumentation Diagram.....	11.2-58
11.3-1	Gaseous Radwaste System Simplified Sketch	11.3-28
11.3-2	Simplified Gaseous Radwaste System Piping and Instrumentation Diagram.....	11.3-29
11.4-1	Waste Processing System Flow Diagram	11.4-36
11.5-1	Process In-Line Radiation Monitor	11.5-25
11.5-2	Safety-Related Containment High Range Radiation Monitor	11.5-26
11.5-3	Containment Atmosphere Radiation Monitor	11.5-27
11.5-4	Plant Vent Radiation Monitor.....	11.5-28
11.5-5	In-Line HVAC Duct Radiation Monitor.....	11.5-29
11.5-6	Safety-Related Main Control Room Supply Duct Radiation Monitor	11.5-30
11.5-7	Liquid Offline Radiation Monitor	11.5-31
11.5-8	Adjacent to Line Radiation Monitor	11.5-32
11.5-9	HVAC Duct Particulate Radiation Monitor.....	11.5-33

Chapter 11 Radioactive Waste Management

11.1 Source Terms

This section addresses the sources of radioactivity that are treated by the liquid and gaseous radwaste systems. Radioactive materials are generated within the core (fission products) and have the potential of leaking to the reactor coolant system by way of defects in the fuel cladding. The core radiation field also results in activation of the coolant to form N-16 from oxygen and the activation of corrosion products in the reactor coolant system.

Two source terms are presented for the primary and the secondary coolant. The first is a conservative, or design basis, source term that assumes the design basis fuel defect level. This source term serves as a basis for system design and shielding requirements.

The second source term is a realistic model. This source term represents the expected average concentrations of radionuclides in the primary and the secondary coolant. These values are determined using the model in the PWR-GALE code (Reference 1) and which provides the bases for estimating typical concentrations of the principal radionuclides that are expected to occur. This source term model reflects the industry experience at a large number of operating PWR plants.

11.1.1 Design Basis Reactor Coolant Activity

11.1.1.1 Fission Products

For the design basis source term it is assumed that there is a significant fuel defect level, well above that anticipated during normal operation. It is assumed that small cladding defects are present in fuel rods producing 0.25 percent of the core power output (also stated as 0.25 percent fuel defects). The defects are assumed to be uniformly distributed throughout the core.

The parameters used in the calculation of the reactor coolant fission product concentrations, including pertinent information concerning the fission product escape rate coefficients, coolant cleanup rate, and demineralizer effectiveness, are listed in Table 11.1-1. Since the fuel defects are assumed to be uniformly distributed in the core, the fission product escape rate coefficients are based on average fuel temperature.

The determination of reactor coolant activity is based on time-dependent fission product core inventories that are calculated by the ORIGEN code (Reference 2).

The fission product activity in the reactor coolant is calculated using the following differential equations.

For parent nuclides in the coolant:

$$\frac{dN_{cp}}{dt} = \frac{FR_p N_{Fp}}{M_c} - \left[\lambda_p + D_p + \frac{Q_L}{M_c} \left(\frac{DF_p - 1}{DF_p} \right) \right] N_{cp}$$

For daughter nuclides in the coolant:

$$\frac{dN_{cd}}{dt} = \frac{FR_d N_{Fd}}{M_c} + f_p \lambda_p N_{c_p} - \left[\lambda_d + D_d + \frac{Q_L}{M_c} \left(\frac{DF_d - 1}{DF_d} \right) \right] N_{cd}$$

where:

- N_c = Concentration of nuclide in the reactor coolant (atoms/gram)
- N_F = Population of nuclide in the fuel (atoms)
- t = Operating time (seconds)
- R = Nuclide release coefficient (1/sec)
- F = Fraction of fuel rods with defective cladding
- M_c = Mass of reactor coolant (grams)
- λ = Nuclide decay constant (1/sec)
- D = Dilution coefficient by feed and bleed (1/sec) = $\frac{\beta}{B_o - \beta t} \times \frac{1}{DF}$
- B_o = Initial boron concentration (ppm)
- β = Boron concentration reduction rate (ppm/sec)
- DF = Nuclide demineralizer decontamination factor
- Q_L = Purification or letdown mass flow rate (grams/sec)
- f = Fraction of parent nuclide decay events that result in the formation of the daughter nuclide

Subscript p refers to the parent nuclide.

Subscript d refers to the daughter nuclide.

Table 11.1-2 lists the resulting reactor coolant radionuclide concentrations. The values presented are the maximum values calculated to occur during the fuel cycle from startup through the equilibrium cycle. Thus, the source term does not represent any particular time in the fuel cycle but is a conservative composite.

The design basis source term based on 0.25 percent fuel defects is used to ensure a consistent set of design values for interfaces among the radioactive waste processing systems. The Technical Specifications in **Chapter 16**, which are related to fuel failure are also based upon 0.25 percent fuel

defects. In addition, the liquid and gaseous radioactive waste processing systems have the capability to process wastes based upon 1.0 percent fuel defects.

11.1.1.2 Corrosion Products

The reactor coolant corrosion product activities are based on operating plant data and are independent of fuel defect level. The concentrations of corrosion products are included in [Table 11.1-2](#).

11.1.1.3 Tritium

A number of tritium production processes add tritium to the reactor coolant:

- Fission product formation in the fuel (ternary fission) forms tritium which can diffuse through the fuel clad or leak through fuel clad defects
- Neutron reactions with soluble boron in the reactor coolant
- Burnable neutron absorber
- Neutron reactions with soluble lithium in the reactor coolant
- Neutron reactions with deuterium in the reactor coolant

The first two processes are the principal contributors to tritium in the reactor coolant. [Table 11.1-3](#) lists the tritium introduced to the reactor coolant from each of the processes.

Tritium exists in the reactor coolant primarily combined with hydrogen (that is, a tritium atom replaces a hydrogen atom in a water molecule) and thus cannot be readily separated from the coolant by normal processing methods. The maximum concentration of tritium in the reactor coolant is less than 3.5 microcuries per gram as a result of losses due to leakage and the controlled release of tritiated water to the environment.

11.1.1.4 Nitrogen-16

Activation of oxygen in the coolant results in the formation of N-16 which is a strong gamma emitter. Because of its short half-life of 7.11 seconds, N-16 is not of concern outside the containment. [Table 12.2-3](#) provides N-16 concentrations at various points in the reactor coolant system. After shutdown, N-16 is not a source of radiation inside of containment.

11.1.2 Design Basis Secondary Coolant Activity

Steam generator tube defects cause the introduction of reactor coolant into the secondary cooling system. The resulting radionuclide concentrations in the secondary coolant depend upon the primary-to-secondary leak rate, the nuclide decay constant, and the steam generator blowdown rate.

The reactor coolant leakage into the secondary system is assumed to have radionuclide concentrations as defined in [Table 11.1-2](#). The parameters used in the calculation of the secondary side activities are provided in [Table 11.1-4](#) and the resulting radionuclide concentrations in the steam generator secondary side water and steam are presented in [Tables 11.1-5](#) and [11.1-6](#).

11.1.3 Realistic Reactor Coolant and Secondary Coolant Activity

The realistic source terms for both the reactor coolant and the secondary coolant are determined using the modeling in ANSI-18.1 (Reference 3). This modeling is also incorporated in the PWR-GALE code. The reference plant values provided in ANSI-18.1 were adjusted to be consistent with the AP1000 parameters listed in Table 11.1-7. The adjustment factors are applied to the fission products. The realistic source term is listed in Table 11.1-8.

11.1.4 Core Source Term

The core fission product inventories used to establish source terms for accident radiological consequence analyses are provided in Appendix 15A.

11.1.5 Process Leakage Sources

The systems containing radioactive liquids are potential sources for the release of radioactive material to plant buildings and then to the environment. The leakage sources and the resulting airborne concentrations are discussed in Section 12.2.

Release pathways for radioactive materials are discussed in Sections 11.2 and 11.3.

11.1.6 Combined License Information

This section contained no requirement for information.

11.1.7 References

1. "Calculation of Releases of Radioactive Materials in Gaseous and Liquid Effluents from Pressurized Water Reactors (PWR-GALE Code)," NUREG-0017, Revision 1, March 1985.
2. RSIC Computer Code Collection CCC-371, ORIGEN 2.1 Isotope Generation and Depletion Code - Matrix Exponential Method, August 1, 1991.
3. ANSI/ANS-18.1-1984, "Radioactive Source Term for Normal Operation of Light Water Reactors."

**Table 11.1-1 (Sheet 1 of 2)
Parameters Used in the Calculation of Design Basis Fission Product Activities**

Core thermal power (MWt)	3,400
Reactor coolant liquid volume (ft ³) ^(a)	9,575
Reactor coolant full-power average temperature (°F)	578.1
Purification flow rate (gal/min) ^(b)	
Maximum	100
Normal	91.3
Effective cation demineralizer flow, annual average (gal/min) ^(b)	9.1
Nuclide release coefficients (the product of the failed fuel fraction and the fission product escape rate coefficient)	
Equivalent fraction of core power produced by fuel rods containing small cladding defects (failed fuel fraction)	0.0025
Fission product escape rate coefficients during full-power operation (s ⁻¹):	
Kr and Xe isotopes	6.5 x 10 ⁻⁸
Br, Rb, I, and Cs isotopes	1.3 x 10 ⁻⁸
Mo, Tc, and Ag isotopes	2.0 x 10 ⁻⁹
Te isotopes	1.0 x 10 ⁻⁹
Sr and Ba isotopes	1.0 x 10 ⁻¹¹
Y, Zr, Nb, Ru, Rh, La, Ce, and Pr isotopes	1.6 x 10 ⁻¹²
Chemical and volume control system mixed bed demineralizers	
Resin volume (ft ³)	50
Demineralizer isotopic decontamination factors:	
Kr and Xe isotopes	1
Br and I isotopes	10
Sr and Ba isotopes	10
Other isotopes	1

**Table 11.1-1 (Sheet 2 of 2)
Parameters Used in the Calculation of Design Basis Fission Product Activities**

Chemical and volume control system cation bed demineralizer	
Resin volume (ft ³)	50
Demineralizer isotopic decontamination factors:	
Kr and Xe isotopes	1
Sr and Ba isotopes	1
Rb-86, Cs-134, and Cs-137	10
Rb-88, Rb-89, Cs-136, and Cs-138	1
Other isotopes	1
Other isotopic removal mechanisms	See Note c.
Initial boron concentration (ppm)	1,400
Operation time (effective full-power hours)	12,492

Notes:

- a. Reactor coolant mass used in defining fission product activities is based on above stated conditions before thermal expansion (conservative).
- b. Flow calculated at 2250 psia and 250°F.
- c. For all isotopes, except the isotopes of Kr, Xe, Br, I, Rb, Cs, Sr, and Ba, a removal decontamination factor of 10 is assumed to account for removal mechanisms other than ion exchange, such as plateout or filtration. This decontamination factor is applied to the normal purification letdown flow.

**Table 11.1-2
Design Basis Reactor Coolant Activity**

Nuclide	Activity ($\mu\text{Ci/g}$)	Nuclide	Activity ($\mu\text{Ci/g}$)
Kr-83m	1.8×10^{-1}	Rb-88	1.5
Kr-85m	8.4×10^{-1}	Rb-89	6.9×10^{-2}
Kr-85	3.0	Sr-89	1.1×10^{-3}
Kr-87	4.7×10^{-1}	Sr-90	4.9×10^{-5}
Kr-88	1.5	Sr-91	1.7×10^{-3}
Kr-89	3.5×10^{-2}	Sr-92	4.1×10^{-4}
Xe-131m	1.3	Y-90	1.3×10^{-5}
Xe-133m	1.7	Y-91m	9.2×10^{-4}
Xe-133	1.2×10^2	Y-91	1.4×10^{-4}
Xe-135m	1.7×10^{-1}	Y-92	3.4×10^{-4}
Xe-135	3.5	Y-93	1.1×10^{-4}
Xe-137	6.7×10^{-2}	Zr-95	1.6×10^{-4}
Xe-138	2.5×10^{-1}	Nb-95	1.6×10^{-4}
Br-83	3.2×10^{-2}	Mo-99	2.1×10^{-1}
Br-84	1.7×10^{-2}	Tc-99m	2.0×10^{-1}
Br-85	2.0×10^{-3}	Ru-103	1.4×10^{-4}
I-129	1.5×10^{-8}	Rh-103m	1.4×10^{-4}
I-130	1.1×10^{-2}	Rh-106	4.5×10^{-5}
I-131	7.1×10^{-1}	Ag-110m	4.0×10^{-4}
I-132	9.4×10^{-1}	Te-127m	7.6×10^{-4}
I-133	1.3	Te-129m	2.6×10^{-3}
I-134	2.2×10^{-1}	Te-129	3.8×10^{-3}
I-135	7.8×10^{-1}	Te-131m	6.7×10^{-3}
Cs-134	6.9×10^{-1}	Te-131	4.3×10^{-3}
Cs-136	1.0	Te-132	7.9×10^{-2}
Cs-137	5.0×10^{-1}	Te-134	1.1×10^{-2}
Cs-138	3.7×10^{-1}	Ba-137m	4.7×10^{-1}
Cr-51	1.3×10^{-3}	Ba-140	1.0×10^{-3}
Mn-54	6.7×10^{-4}	La-140	3.1×10^{-4}
Mn-56	1.7×10^{-1}	Ce-141	1.6×10^{-4}
Fe-55	5.0×10^{-4}	Ce-143	1.4×10^{-4}
Fe-59	1.3×10^{-4}	Pr-143	1.5×10^{-4}
Co-58	1.9×10^{-3}	Ce-144	1.2×10^{-4}
Co-60	2.2×10^{-4}	Pr-144	1.2×10^{-4}

Note:

These activities are used for shielding and radwaste system interface design. For 1 percent fuel defect calculations (maximum release and liquid and gaseous radwaste system capability) multiply the activities above by 4 except for corrosion products (Cr-51, Mn-54, Mn-56, Fe-55, Fe-59, Co-58 and Co-60).

**Table 11.1-3
Tritium Sources**

Tritium Source	Release to Coolant (curies/cycle ¹)	
	Design Basis	Best Estimate
Produced in core		
Ternary fission	1770	354
Burnable absorbers	279	56
Produced in coolant		
Soluble boron	734	734
Soluble lithium	168	168
Deuterium	4	4
TOTAL	2955	1316

Note:

1. Cycle length of 18 months. Design basis case reflects the historical assumption that 10% of the tritium produced in the core is released to the coolant. Best-estimate case is based on a release of only 2% of the tritium.

**Table 11.1-4
Parameters Used to Calculate Secondary Coolant Activity**

Total secondary side water mass (lb/steam generator)	1.76 x 10 ⁵
Steam generator steam fraction	0.055
Total steam flow rate (lb/hr)	1.5 x 10 ⁷
Moisture carryover (percent)	0.1
Total makeup water feed rate (lb/hr)	732
Total blowdown rate (gpm)	186
Total primary-to-secondary leak rate (gpd)	500
Iodine partition factor (mass basis)	100

**Table 11.1-5
Design Basis Steam Generator Secondary Side Liquid Activity**

Nuclide	Activity ($\mu\text{Ci/g}$)	Nuclide	Activity ($\mu\text{Ci/g}$)
Br-83	2.3×10^{-5}	Y-93	1.5×10^{-7}
Br-84	4.0×10^{-6}	Zr-95	2.7×10^{-7}
Br-85	4.9×10^{-8}	Nb-95	2.7×10^{-7}
I-129	2.4×10^{-11}	Mo-99	3.4×10^{-4}
I-130	1.4×10^{-5}	Tc-99m	3.2×10^{-4}
I-131	1.1×10^{-3}	Ru-103	2.3×10^{-7}
I-132	7.3×10^{-4}	Rh-103m	2.3×10^{-7}
I-133	1.8×10^{-3}	Rh-106	2.0×10^{-10}
I-134	8.1×10^{-5}	Ag-110m	6.7×10^{-7}
I-135	8.7×10^{-4}	Te-127m	1.3×10^{-6}
Rb-88	2.3×10^{-4}	Te-127	3.2×10^{-7}
Rb-89	8.9×10^{-6}	Te-129m	4.4×10^{-6}
Cs-134	2.1×10^{-3}	Te-129	3.8×10^{-6}
Cs-136	3.0×10^{-3}	Te-131m	1.0×10^{-5}
Cs-137	1.5×10^{-3}	Te-131	2.8×10^{-6}
Cs-138	9.5×10^{-5}	Te-132	1.3×10^{-4}
H-3	1.0	Te-134	3.2×10^{-6}
Cr-51	2.2×10^{-6}	Ba-137m	1.4×10^{-3}
Mn-54	1.1×10^{-6}	Ba-140	1.7×10^{-6}
Mn-56	1.3×10^{-4}	La-140	6.0×10^{-7}
Fe-55	8.4×10^{-7}	Ce-141	2.6×10^{-7}
Fe-59	2.2×10^{-7}	Ce-143	2.2×10^{-7}
Co-58	3.2×10^{-6}	Ce-144	1.9×10^{-7}
Co-60	3.7×10^{-7}	Pr-143	2.5×10^{-7}
Sr-89	3.3×10^{-6}	Pr-144	1.9×10^{-7}
Sr-90	1.5×10^{-7}		
Sr-91	3.3×10^{-6}		
Sr-92	4.0×10^{-7}		
Y-90	2.7×10^{-8}		
Y-91m	1.8×10^{-6}		
Y-91	2.3×10^{-7}		
Y-92	4.9×10^{-7}		

Table 11.1-6
Design Basis Steam Generator Secondary Side Steam Activity

Nuclide	Activity ($\mu\text{Ci/g}$)
Kr-83m	1.8×10^{-6}
Kr-85m	7.2×10^{-6}
Kr-85	2.5×10^{-5}
Kr-87	4.1×10^{-6}
Kr-88	1.3×10^{-5}
Kr-89	3.0×10^{-7}
Xe-131m	1.2×10^{-5}
Xe-133m	1.4×10^{-5}
Xe-133	1.1×10^{-3}
Xe-135m	1.0×10^{-5}
Xe-135	3.1×10^{-5}
Xe-137	5.7×10^{-7}
Xe-138	2.1×10^{-6}
I-129	2.7×10^{-13}
I-130	1.5×10^{-7}
I-131	1.3×10^{-5}
I-132	8.0×10^{-6}
I-133	2.0×10^{-5}
I-134	8.9×10^{-7}
I-135	9.5×10^{-6}
H-3	1.0

**Table 11.1-7
Parameters Used to Describe Realistic Sources**

Parameter	Symbol	Units	AP1000 Value	Nominal Value
Thermal power	P	MWt	3400	3400
Steam flow rate	FS	lb/hr	1.5×10^7	1.5×10^7
Weight of water in reactor coolant system	WP	lb	4.3×10^5	5.5×10^5
Weight of water in all steam generators	WS	lb	3.5×10^5	4.5×10^5
Reactor coolant purification flow	FD	lb/hr	4.3×10^4	3.7×10^4
Reactor coolant letdown flow (yearly average for boron control)	FB	lb/hr	1.5×10^2	5.0×10^2
Steam generator blowdown flow (total)	FBD	lb/hr	7.5×10^4	7.5×10^4
Fraction of radioactivity in blowdown stream which is not returned to the secondary coolant system	NBD	-	0.0	1.0
Flow through the purification system cation demineralizer	FA	lb/hr	4.3×10^3	3.7×10^3
Ratio of condensate demineralizer flow rate to the total steam flow rate	NC	-	0.33	0.0
Fraction of the noble gas activity in the letdown stream which is not returned to the reactor coolant system	Y	-	0.0	0.0
Primary-to-secondary leakage	FL	lb/day	75	75

**Table 11.1-8 (Sheet 1 of 4)
Realistic Source Terms**

Noble Gases			
Nuclide	Reactor Coolant Activity (μCi/g)	Steam Generator Steam Activity (μCi/g)	
Kr-85m	0.21	4.4 x 10 ⁻⁸	
Kr-85	1.4	2.9 x 10 ⁻⁷	
Kr-87	0.19	3.9 x 10 ⁻⁸	
Kr-88	0.36	7.7 x 10 ⁻⁸	
Xe-131m	1.1	2.3 x 10 ⁻⁷	
Xe-133m	0.093	2.0 x 10 ⁻⁸	
Xe-133	3.6	7.6 x 10 ⁻⁷	
Xe-135m	0.17	3.5 x 10 ⁻⁸	
Xe-135	1.1	2.3 x 10 ⁻⁷	
Xe-137	0.044	9.2 x 10 ⁻⁹	
Xe-138	0.15	3.2 x 10 ⁻⁸	
Halogens			
Nuclide	Reactor Coolant Activity (μCi/g)	Steam Generator Liquid Activity (μCi/g)	Steam Generator Steam Activity (μCi/g)
Br-84	0.02	1.2 x 10 ⁻⁷	1.2 x 10 ⁻⁹
I-131	0.04	2.7 x 10 ⁻⁶	2.7 x 10 ⁻⁸
I-132	0.25	5.1 x 10 ⁻⁶	5.1 x 10 ⁻⁸
I-133	0.14	7.4 x 10 ⁻⁶	7.4 x 10 ⁻⁸
I-134	0.42	3.9 x 10 ⁻⁶	3.9 x 10 ⁻⁸
I-135	0.28	1.1 x 10 ⁻⁵	1.1 x 10 ⁻⁷

**Table 11.1-8 (Sheet 2 of 4)
Realistic Source Terms**

Rubidium, Cesium			
Nuclide	Reactor Coolant Activity (μCi/g)	Steam Generator Liquid Activity (μCi/g)	Steam Generator Steam Activity (μCi/g)
Rb-88	0.24	8.9×10^{-7}	4.4×10^{-9}
Cs-134	5.9×10^{-3}	1.5×10^{-6}	7.6×10^{-9}
Cs-136	7.4×10^{-4}	1.7×10^{-7}	8.7×10^{-10}
Cs-137	7.9×10^{-3}	2.0×10^{-6}	9.9×10^{-9}
Tritium			
Nuclide	Reactor Coolant Activity (μCi/g)	Steam Generator Liquid Activity (μCi/g)	Steam Generator Steam Activity (μCi/g)
H-3	1	1.0×10^{-3}	1.0×10^{-3}

Table 11.1-8 (Sheet 3 of 4)
Realistic Source Terms

Miscellaneous Nuclides			
Nuclide	Reactor Coolant Activity ($\mu\text{Ci/g}$)	Steam Generator Liquid Activity ($\mu\text{Ci/g}$)	Steam Generator Steam Activity ($\mu\text{Ci/g}$)
Na-24	4.6×10^{-2}	3.6×10^{-6}	1.8×10^{-8}
Cr-51	2.6×10^{-3}	3.6×10^{-7}	1.8×10^{-9}
Mn-54	1.3×10^{-3}	1.8×10^{-7}	9.2×10^{-10}
Fe-55	1.0×10^{-3}	1.4×10^{-7}	7.0×10^{-10}
Fe-59	2.5×10^{-4}	3.3×10^{-8}	1.7×10^{-10}
Co-58	3.9×10^{-3}	5.3×10^{-7}	2.6×10^{-9}
Co-60	4.4×10^{-4}	6.1×10^{-8}	3.1×10^{-10}
Zn-65	4.3×10^{-4}	5.9×10^{-8}	2.8×10^{-10}
Sr-89	1.2×10^{-4}	1.6×10^{-8}	8.1×10^{-11}
Sr-90	1.0×10^{-5}	1.4×10^{-9}	7.0×10^{-12}
Sr-91	9.8×10^{-4}	6.4×10^{-8}	3.2×10^{-10}
Y-90	1.2×10^{-6}	1.6×10^{-10}	8.0×10^{-13}
Y-91m	5.7×10^{-4}	5.6×10^{-9}	2.8×10^{-11}
Y-91	4.4×10^{-6}	5.9×10^{-10}	3.1×10^{-12}
Y-93	4.3×10^{-3}	2.8×10^{-7}	1.4×10^{-9}
Zr-95	3.3×10^{-4}	4.5×10^{-8}	2.2×10^{-10}
Nb-95	2.4×10^{-4}	3.1×10^{-8}	1.6×10^{-10}
Mo-99	5.6×10^{-3}	6.7×10^{-7}	3.2×10^{-9}
Tc-99m	5.1×10^{-3}	2.4×10^{-7}	1.2×10^{-9}
Ru-103	6.3×10^{-3}	8.6×10^{-7}	4.5×10^{-9}
Ru-106	7.5×10^{-2}	1.0×10^{-5}	5.0×10^{-8}
Rh-103m	6.3×10^{-3}	8.6×10^{-7}	4.5×10^{-9}
Rh-106	7.5×10^{-2}	1.0×10^{-5}	5.0×10^{-8}
Ag-110m	1.1×10^{-3}	1.5×10^{-7}	7.5×10^{-10}
Te-129m	1.6×10^{-4}	2.2×10^{-8}	1.1×10^{-10}

**Table 11.1-8 (Sheet 4 of 4)
Realistic Source Terms**

Miscellaneous Nuclides			
Nuclide	Reactor Coolant Activity (μCi/g)	Steam Generator Liquid Activity (μCi/g)	Steam Generator Steam Activity (μCi/g)
Te-129	2.9×10^{-2}	3.9×10^{-7}	2.0×10^{-9}
Te-131m	1.4×10^{-3}	1.4×10^{-7}	7.0×10^{-10}
Te-131	9.7×10^{-3}	4.9×10^{-8}	2.5×10^{-10}
Te-132	1.5×10^{-3}	1.8×10^{-7}	8.9×10^{-10}
Ba-137m	7.4×10^{-3}	1.9×10^{-6}	9.3×10^{-9}
Ba-140	1.1×10^{-2}	1.4×10^{-6}	7.2×10^{-9}
La-140	2.3×10^{-2}	2.4×10^{-6}	1.2×10^{-8}
Ce-141	1.3×10^{-4}	1.7×10^{-8}	8.6×10^{-11}
Ce-143	2.6×10^{-3}	2.6×10^{-7}	1.3×10^{-9}
Ce-144	3.4×10^{-3}	4.5×10^{-7}	2.3×10^{-9}
Pr-143	3.0×10^{-3}	3.3×10^{-7}	1.8×10^{-9}
Pr-144	3.4×10^{-3}	4.5×10^{-7}	2.3×10^{-9}
W-187	2.3×10^{-3}	2.2×10^{-7}	1.1×10^{-9}
Np-239	2.0×10^{-3}	2.2×10^{-7}	1.1×10^{-9}

11.2 Liquid Waste Management Systems

The liquid waste management systems include the systems that may be used to process and dispose of liquids containing radioactive material. These include the following:

- Steam generator blowdown processing system ([Subsection 10.4.8](#));
- Radioactive waste drain system ([Subsection 9.3.5](#));
- Liquid radwaste system (WLS) (Section 11.2).

This section primarily addresses the liquid radwaste system. The other systems are also addressed in [Subsection 11.2.3](#), which discusses the expected releases from the liquid waste management systems.

The liquid radwaste system is designed to control, collect, process, handle, store, and dispose of liquid radioactive waste generated as the result of normal operation, including anticipated operational occurrences.

11.2.1 Design Basis

[Subsection 1.9.1](#) discusses the conformance of the liquid radwaste system design with the criteria of Regulatory Guide 1.143.

11.2.1.1 Safety Design Basis

The liquid radwaste system serves no safety-related functions except for:

- Containment isolation; see [Subsection 6.2.3](#).
- Back flow prevention check valves in the drain lines from the chemical and volume control system compartment and the passive core cooling system compartments to the containment sump, which prevent cross flooding of these compartments. Each drain line has two check valves in series so that a single failure does not compromise the back flow prevention safety function. See [Subsection 6.3.3.3.2](#) for a discussion of containment flooding.

11.2.1.2 Power Generation Design Basis

11.2.1.2.1 Capacity

The liquid radwaste system provides holdup capacity as shown in [Table 11.2-2](#), and permanently installed processing capacity of 75 gpm through the ion exchange/filtration train. This is adequate capacity to meet the anticipated processing requirements of the plant. The projected flows of various liquid waste streams to the liquid radwaste system under normal conditions are identified in [Table 11.2-1](#).

The liquid radwaste system design can accept equipment malfunctions without affecting the capability of the system to handle both anticipated liquid waste flows and possible surge load due to excessive leakage. [Table 11.2-4](#) contains information on the surge capacity of individual tanks.

Portions of the liquid radwaste system may become unavailable as a result of the malfunctions listed in [Subsection 11.2.1.2.2](#).

Ample surge capacity of the system, provisions for using mobile processing equipment and the low load factor of the processing equipment permits the system to accommodate waste until failures can

be repaired and normal plant operation resumed. In addition, the liquid radwaste system is designed to accommodate the anticipated operational occurrences described in [Subsection 11.2.1.2.3](#).

11.2.1.2.2 Failure Tolerance

11.2.1.2.2.1 Pump Failure

Where operation is not essential and surge capacity is available, a single pump is provided. This applies to most applications in the liquid radwaste system. Two reactor coolant drain tank pumps and two containment sump pumps are provided because the relative inaccessibility of the containment during power operation would hinder maintenance. [The containment sump pumps are submersible pumps](#). To protect them from damage due to loss of suction, each pump is interlocked to stop on a low level condition in the sump. The reactor coolant drain tank pumps are vertical sump type pumps with motors above the reactor coolant drain tank shaft coupled to pumps submersed in the liquid within the reactor coolant drain tank. This arrangement minimizes contamination of the motors and permits removal and maintenance of the motors outside of the radiation area.

Process pumps located outside containment are air-operated, double diaphragm type. These pumps are capable of significant suction lifts, and can thus be located on or near the top of the associated waste tank, with internal suction piping. They can pump slurries with high solids fractions, run deadheaded, and run dry without damage. In addition, they can operate over a wide range of hydraulic conditions by varying the driving air input. This makes it possible to fulfill many different applications with a single pump model, thereby facilitating maintenance and reducing the inventory of spare parts.

11.2.1.2.2.2 Filter or Ion Exchanger Plugging

Instrumentation is provided to give indication of the pressure drop across filters and ion exchangers. Periodic checks of the pressure drops provide indication of equipment fouling, thus permitting corrective action to be taken before an excessive pressure drop is reached. Change of filter cartridges and ion exchange beds is expected to occur based upon radiation survey.

11.2.1.2.3 Anticipated Operational Occurrences

11.2.1.2.3.1 High Primary Coolant System Leakage Rate

The system is designed to handle an abnormal primary coolant system leak in addition to the expected leakage during normal operation. Operation of the system is the same as for normal operation, except that the load on the system is increased.

11.2.1.2.3.2 High Use of Decontamination Water

If large quantities of water are used to decontaminate areas or equipment, the load on the liquid radwaste system is increased. However, the liquid radwaste system is designed to handle a large, continuous input to the waste holdup tanks. If the water can be discharged without processing based on sampling which shows acceptably low activity, the overall liquid radwaste system capacity is increased.

To accommodate the possible use of special decontamination fluids or very large volumes of decontamination fluids, mobile equipment is used as discussed in [Subsection 11.2.1.2.5.2](#).

11.2.1.2.3.3 Steam Generator Tube Leakage

During normal operations, steam generator blowdown is returned to the condensate system, as described in [Subsection 10.4.8](#). However, if excessive radioactivity is detected, the blowdown is diverted to the liquid radwaste system for processing and disposal.

The blowdown fluid is brought into the waste holdup tanks, which provide some surge capacity to hold the fluid during processing. It is then processed in the same fashion as, and combined with, other inputs.

In the event of a steam generator tube rupture, the condensate storage tank may also become contaminated. In this event, the tank is cleaned by the use of temporary equipment brought to the site for the purpose, as described in [Subsection 11.2.1.2.5.2](#).

11.2.1.2.3.4 Refueling

The load on the liquid radwaste system is expected to increase during refueling because of the increased level of maintenance activities in the plant, but operation is the same as for normal plant operation. There is no significant effect on the performance capability of the liquid radwaste system.

11.2.1.2.4 Controlled Release of Radioactivity

The liquid radwaste system provides the capability to reduce the amounts of radioactive nuclides released in the liquid wastes through the use of demineralization and time delay for decay of short-lived nuclides.

The assumed equipment decontamination factors appear in [Table 11.2-5](#). Estimates of the radioactive source terms and annual average flow rate that will be processed in the liquid radwaste system or discharged to the environment during normal operation appear in [Table 11.2-1](#).

Before radioactive liquid waste is discharged, it is pumped to a monitor tank. A sample of the monitor tank contents is analyzed, and the results are recorded. In this way, a record is kept of planned releases of radioactive liquid waste.

The liquid waste is discharged from the monitor tank in a batch operation, and the discharge flow rate is restricted as necessary to maintain an acceptable concentration when diluted by the circulating water discharge flow. These provisions preclude uncontrolled releases of radioactivity.

In addition, the discharge line contains a radiation monitor with diverse methods of stopping the discharge. The first method closes an isolation valve in the discharge line, which prevents any further discharge from the liquid radwaste system. The valve automatically closes and an alarm is actuated if the activity in the discharge stream reaches the monitor setpoint. The second method stops the monitor tank pumps.

To minimize leakage from the liquid radwaste system, the portion of the system normally expected to contain radioactive material is of welded construction except where flanged connections are required to facilitate component maintenance or to allow connection of temporary or mobile equipment. Air-operated diaphragm pumps, sealless pumps, or pumps having mechanical seals are used. These pumps minimize system leakage thereby minimizing the release of radioactive gas that might be entrained in the leaking fluid to the building atmosphere.

Provisions are made to control spills of radioactive liquids due to tank overflows. [Table 11.2-3](#) lists the provisions for tank level indication, alarms, and overflow disposition for liquid radwaste system tanks outside containment. In addition, the radioactive waste collection tanks (i.e., the effluent holdup

tanks, waste holdup tanks, and chemical tank) are located within the auxiliary building, which is well sealed and equipped with an extensive floor drain system. The radwaste monitor tanks are located in the auxiliary building and in the radwaste building, which has a well sealed, contiguous basemat with integral curbing and a floor drain system. Routing of both of the auxiliary building and radwaste building floor drain systems are to the liquid radwaste system. This eliminates the potential for undetected tank leakage to the environment and supports compliance with 10 CFR 20.1406 (Reference 5).

The liquid radwaste system is designed so that the annual average concentration limits established by 10 CFR 20 (Appendix B, table 2, column 2) (Reference 1) for liquid releases are not exceeded during plant operation. Subsection 11.2.3 describes the calculated releases of radioactive materials from the liquid radwaste system and other portions of the liquid waste management systems resulting from normal operation.

The monitored radwaste discharge pipeline is engineered to preclude leakage to the environment. This pipe is routed from the auxiliary building to the radwaste building (the short section of pipe between the two buildings is fully available for visual inspection as noted above) and then out of the radwaste building to the licensed release point for dilution and discharge. The discharge radiation monitor and isolation valve are located inside the radiologically controlled area. The exterior piping is designed to preclude inadvertent or unidentified releases to the environment; it is either enclosed within a guard pipe and monitored for leakage, or accessible for visual inspection. No valves or vacuum breakers are incorporated outside of monitored structures. This greatly reduces the potential for undetected leakage from this discharge to the environment at a non-licensed release point, and supports compliance with 10 CFR 20.1406 (Reference 5).

The liquid radwaste system (WLS) exterior discharge piping from the Units 3 and 4 Radwaste Building is buried, stainless steel, enclosed within a guard pipe and monitored for leakage to comply with 10 CFR 20.1406. The WLS discharge lines connect to the Waste Water System (WWS) plant outfall pipe within the Exclusion Area Boundary for dilution below the release limits of 10 CFR Part 20, Appendix B, Table II, Column 2. Dilution at this point, downstream of the WWS blowdown sump, is primarily supplied by the circulating water blowdown flow. The blowdown sump and plant outfall are described in Subsection 9.2.9.2.2.

The WWS blowdown line to the plant outfall at the Savannah River is a high density polyethylene single-walled buried pipe. There are no valves, vacuum breakers, or pumps along the WWS blowdown line between the point where the WLS connects and the plant outfall. Monitoring for leakage downstream of the WLS radwaste discharge line connection is per NEI 08-08A (Reference 201) as described in Appendix 12AA. This monitoring will be implemented as part of the Units 3 and 4 groundwater monitoring program.

11.2.1.2.4.1 Abnormal Operation

Subsections 11.2.1.2.2 and 11.2.1.2.3 describe the capability of the liquid radwaste system to accommodate abnormal conditions for various equipment and other anticipated operational occurrences. During these anticipated occurrences, the effectiveness of the liquid radwaste system in controlling releases of radioactivity remains unaffected, so releases are limited as during normal operation.

Subsection 11.2.3 discusses the calculated releases of radioactive materials from the liquid radwaste system for abnormal situations.

11.2.1.2.5 Equipment Design

11.2.1.2.5.1 Permanently Installed Equipment

The liquid radwaste system equipment design parameters are provided in [Table 11.2-2](#).

The seismic design classification and safety classification for the liquid radwaste system components and structures are listed in [Section 3.2](#). The components listed are located in the Seismic Category I Nuclear Island and in the radwaste building.

The monitor tanks in the non-seismic radwaste building are used to store processed water. The radioactivity content of processed water in each tank will be less than the A₁ and A₂ levels of 10 CFR 71 Appendix A, Table A-1.

11.2.1.2.5.2 Use of Mobile and Temporary Equipment

The liquid radwaste system is designed to handle most liquid effluents and other anticipated events using installed equipment. However, for events occurring at a very low frequency or producing effluents not compatible with the installed equipment, temporary equipment may be brought into the radwaste building mobile treatment facility truck bays.

Connections are provided to and from various locations in the liquid radwaste system to these mobile equipment connections. This allows the mobile equipment to be used in series with installed equipment, as an alternate to it with the treated liquids returned to the liquid radwaste system, or as an ultimate disposal point for liquids that are to be removed from the plant site for disposal elsewhere.

The use of temporary equipment is common practice in operating plants. The radwaste building truck bays and laydown space for mobile equipment, in addition to the flexibility of numerous piping connections to the liquid radwaste system, allow the plant operator to incorporate mobile equipment in an integrated fashion.

Temporary equipment is also used to clean up the condensate storage tank if it becomes contaminated following steam generator tube leakage. This use of temporary equipment is similar to that just described, except that the equipment is used in the yard rather than in the radwaste building truck bays.

When mobile or temporary equipment is selected to process liquid effluents, the equipment design and testing meets the applicable requirements of Regulatory Guide 1.143. When confirmed through sampling that the radioactive waste contents do not exceed the A₂ quantities for radionuclides specified in Appendix A to 10 CFR Part 71, the liquid effluent may be processed with mobile or temporary equipment in the Radwaste Building. When the A₂ quantities are exceeded, liquid effluent is processed in the Seismic Category I auxiliary building.

Mobile and temporary equipment are designed in accordance with the applicable mobile and temporary radwaste treatment systems guidance provided in Regulatory Guide 1.143, including the codes and standards listed in Table 1 of the Regulatory Guide.

Mobile and temporary equipment has the following features:

- Level indication and alarms (high-level) on tanks.
- Screwed connections are permitted only for instrument connections beyond the first isolation valve.

- Remote operated valves are used where operations personnel would be required to frequently manipulate a valve.
- Local control panels are located away from the equipment, in low dose areas.
- Instrumentation readings are accessible from the local control panels (i.e., temperature, flow, pressure, liquid level, etc.).
- Wetted parts are 300 series stainless steel, except flexible hose and gaskets.
- Flexible hose is used only for mobile equipment within the designated “black box” locations between mobile components and at the interface with the permanent plant piping.
- The contents of tanks are capable of being mixed, either through recirculation or with a mixer.
- Grab sample points are located in tanks and upstream and downstream of the process equipment.

Inspection and testing of mobile or temporary equipment is in accordance with the codes and standards listed in Table 1 of Regulatory Guide 1.143 with the following additions:

- After placement in the station, the mobile or temporary equipment is hydrostatically, or pneumatically, tested prior to tie-in to permanent plant piping.
- A functional test, using demineralized water, is performed. Remote operated valves are stroked (open-closed-open or closed-open-closed) under full flow conditions. The proper function of the instrumentation, including alarms, is verified. The operating procedures are verified correct during the functional test.
- Tank overflows are routed to floor drains.
- Floor drains are confirmed to be functional prior to placing mobile or temporary equipment into operation.

11.2.1.3 Compliance with 10 CFR 20.1406

In accordance with the requirements of 10 CFR 20.1406 ([Reference 5](#)), the liquid radwaste system is designed to minimize, to the extent practicable, contamination of the facility and the environment, facilitate decommissioning, and minimize, to the extent practicable, the generation of radioactive waste. This is done through appropriate selection of design technology for the system, and incorporation of the ability to update the system to use the best available technology throughout the life of the plant.

11.2.2 System Description

The liquid radwaste system, shown in [Figure 11.2-1](#), includes tanks, pumps, ion exchangers, and filters. The liquid radwaste system is designed to process, or store for processing by mobile equipment, radioactively contaminated wastes in four major categories:

- Borated, reactor-grade, waste water – this input is collected from the reactor coolant system (RCS) effluents received through the chemical and volume control system (CVS), primary sampling system sink drains and equipment leakoffs and drains.

- Floor drains and other wastes with a potentially high suspended solids content – this input is collected from various building floor drains and sumps.
- Detergent wastes – this input comes from the plant hot sinks and showers, and some cleanup and decontamination processes. It generally has low concentrations of radioactivity.
- Chemical waste – this input comes from the laboratory and other relatively small volume sources. It may be mixed hazardous and radioactive wastes or other radioactive wastes with a high dissolved-solids content.

Nonradioactive secondary-system waste is not processed by the liquid radwaste system.

Secondary-system effluent is normally handled by the steam generator blowdown processing system and the waste water system as described in [Subsection 10.4.8](#).

Radioactivity can enter the secondary systems from steam generator tube leakage. If significant radioactivity is detected in secondary-side systems, blowdown is diverted to the liquid radwaste system for processing and disposal.

11.2.2.1 Waste Input Streams

11.2.2.1.1 Reactor Coolant System Effluents

The effluent subsystem receives borated and hydrogen-bearing liquid from two sources: the reactor coolant drain tank and the chemical and volume control system. The reactor coolant drain tank collects leakage and drainage from various primary systems and components inside containment. Effluent from the chemical and volume control system is produced mainly as a result of reactor coolant system heatup, boron concentration changes and RCS level reduction for refueling.

Input collected by the effluent subsystem normally contains hydrogen and dissolved radiogases. Therefore, it is routed through the liquid radwaste system vacuum degasifier before being stored in the effluent holdup tanks.

The liquid radwaste system degasifier can also be used to degas the reactor coolant system before shutdown by operating the chemical and volume control system in an open loop configuration. This is done by taking one of the effluent holdup tanks out of normal waste service and draining it. Then normal chemical and volume control system letdown is directed through the degasifier to the dedicated effluent holdup tank. From there, it is pumped back to the suction of the chemical and volume control system makeup pumps with the effluent holdup tank pump. The makeup pumps return the fluid to the reactor coolant system in the normal fashion. This process is continued as necessary for degassing the reactor coolant system as described in [Subsection 9.3.6](#).

The input to the reactor coolant drain tank is potentially at high temperature. Therefore, provisions are made for recirculation through a heat exchanger for cooling. The tank is inerted with nitrogen and is vented to the gaseous radwaste system. Transfer of water from the reactor coolant drain tank is controlled to maintain an essentially fixed tank level to minimize tank pressure variation.

Reactor coolant system effluents from the chemical and volume control system letdown line or the reactor coolant drain subsystem pass through the vacuum degasifier, where dissolved hydrogen and fission gases are removed. These gaseous components are sent via a water separator to the gaseous radwaste system. A degasifier discharge pump then transfers the liquid to the currently selected effluent holdup tank. If flows from the letdown line and the reactor coolant drain tank are routed to the degasifier concurrently, the letdown flow has priority and the drain tank input is automatically suspended.

In the event of abnormally high degasifier water level, inputs are automatically stopped by closing the letdown control and containment isolation valves.

The effluent holdup tanks vent to the radiologically controlled area ventilation system and, in abnormal conditions, may be purged with air to maintain a low hydrogen gas concentration in the tanks' atmosphere. Hydrogen monitors are included in the tanks vent lines to alert the operator of elevated hydrogen levels.

The contents of the effluent holdup tanks may be recirculated and sampled, recycled through the degasifier for further gas stripping, returned to the reactor coolant system via the chemical and volume control system makeup pumps, discharged to the mobile treatment facility, processed through the ion exchangers, or directed to the monitor tanks for discharge without treatment.

Processing through the ion exchangers is the normal mode.

The AP1000 liquid radwaste system processes waste with an upstream filter followed by four ion exchange resin vessels in series. Any of these vessels can be manually bypassed and the order of the last two can be interchanged, so as to provide complete usage of the ion exchange resin.

The top of the first vessel is normally charged with activated carbon, to act as a deep-bed filter and remove oil from floor drain wastes. Moderate amounts of other wastes can also be routed through this vessel. It can be bypassed for processing of relatively clean waste streams. This vessel is somewhat larger than the other three, with an extra sluice connection to allow the top bed of activated carbon to be removed. This feature is associated with the deep bed filter function of the vessel; the top layer of activated carbon collects particulates, and the ability to remove it without disturbing the underlying zeolite bed minimizes solid-waste production.

The second, third and fourth beds are in identical ion exchange vessels, which are selectively loaded with resin, depending on prevailing plant conditions.

After deionization, the water passes through an after-filter where radioactive particulates and resin fines are removed. The processed water then enters one of the monitor tanks. When one of the monitor tanks is full, the system is automatically realigned to route processed water to another tank.

The contents of the monitor tank are recirculated and sampled. In the unlikely event of radioactivity in excess of operational targets, the tank contents are returned to a waste holdup tank for additional processing.

Normally, however, the radioactivity will be well below the discharge limits, and the dilute boric acid is discharged for dilution to the circulating water blowdown. The discharge flow rate is set to limit the boric acid concentration in the circulating water blowdown stream to an acceptable concentration for local requirements. Detection of high radiation in the discharge stream stops the discharge flow and operator action is required to re-establish discharge. The raw water system which provides makeup for the circulating water system is used as a backup source for dilution water when cooling tower blowdown is not available for the discharge path.

11.2.2.1.2 Floor Drains and Other Wastes with Potentially High Suspended Solid Contents

Potentially contaminated floor drain sumps and other sources that tend to be high in particulate loading are collected in the waste holdup tank. Additives may be introduced to the tank to improve filtration and ion exchange processes. Tank contents may be recirculated for mixing and sampling. The tanks have sufficient holdup capability to allow time for realignment and maintenance of the process equipment.

The waste water is processed through the waste pre-filter to remove the bulk of the particulate loading. Next it passes through the ion exchangers and the waste after-filter before entering a monitor tank. The monitor tank contents are sampled and, if necessary, returned to a waste holdup tank and processed through the filters and ion exchangers.

Waste water meeting the discharge limits is discharged to the circulating water blowdown through a radiation detector that stops the discharge if high radiation is detected.

11.2.2.1.3 Detergent Wastes

The detergent wastes from the plant hot sinks and showers contain soaps and detergents. These wastes are generally not compatible with the ion exchange resins described in Subsections 11.2.2.1.1 and 11.2.2.1.2. The detergent wastes are not processed and are collected in the chemical waste tank. If the detergent wastes activity is low enough, the wastes can be discharged without processing.

When sufficient detergent wastes are produced and processing is necessary, mobile processing equipment is brought into one of the radwaste building mobile systems facility truck bays provided for this purpose.

11.2.2.1.4 Chemical Wastes

Inputs to the chemical waste tank normally are generated at a low rate. These wastes are only collected; no internal processing is provided. Chemicals can be added to the tank for pH or other adjustment. Since the volume of these wastes is low, they can be treated by the use of mobile equipment or by shipment offsite.

11.2.2.1.5 Steam Generator Blowdown

Steam generator blowdown is normally accommodated within the steam generator blowdown system, which is described in Subsection 10.4.8.

If steam generator tube leakage results in significant levels of radioactivity in the steam generator blowdown stream, this stream is redirected to the liquid radwaste system for treatment before release. In this event, one of the waste holdup tanks is drained to prepare it for blowdown processing. The blowdown stream is brought into that holdup tank, and continuously or in batches pumped through the waste ion exchangers. The number of ion exchangers in service is determined by the operator to provide adequate purification without excessive resin usage. The blowdown is then collected in a monitor tank, sampled, and discharged in a monitored fashion.

11.2.2.1.6 Prevention of Commingling of Chelating Agents With Radioactive Liquids

Chelating agents, as defined in 10 CFR 61.2, are not routinely used in liquid radioactive waste processing at VEGP Units 1 and 2, and similarly, they will not be routinely used in liquid radioactive processing at VEGP Units 3 and 4. In the event chelating agents are required for a specific purpose (such as cleaning of steam generators or other plant systems), an evaluation will be conducted prior to use, and specific controls will be implemented to ensure that wastes are segregated and managed appropriately to prevent commingling with plant's normal liquid radwaste system.

11.2.2.2 Other Operations

11.2.2.2.1 Sampling

Grab sampling taps are provided where required to monitor influent boron and radioactivity concentrations; to monitor performance of various components; to determine tank water characteristics before transfer, processing or discharge; to verify performance of the on-line analyzers; and to collect samples of discharges to the environs for analysis and documentation. Samples are taken in low radiation areas.

11.2.2.2.2 Tank Cleaning

Extraordinary measures for tank cleaning are not normally required because the pumps take suction from the low point of the tank, and the tank bottoms are sloped so that the tank can be fully drained. Recirculation connections are provided to allow the tanks to be effectively mixed. Also, the air-operated double-diaphragm pumps used can pump air, water or slurries without damage, and can run dry to clear the bottoms of the tanks.

Provisions are made for tank cleaning using a portable tank cleaning rig. Suction is taken from the tank bottom via a temporary hose. The pump discharge passes through a filter and the hose to a tank cleaning lance, which is manually inserted through a manway on the tank. The operator can direct the high-velocity water throughout the inside of the tank.

11.2.2.3 Component Description

The general descriptions and summaries of the design basis requirements for the liquid radwaste system components follow. [Table 11.2-2](#) contains the operating parameters for the liquid radwaste system components.

Additional information regarding the applicable codes and classifications is also available in [Section 3.2](#).

11.2.2.3.1 Liquid Radwaste System Pumps

Reactor Coolant Drain Tank Pumps

Two full-capacity, stainless steel, reactor coolant drain tank pumps recirculate the reactor coolant drain tank contents for cooling and to discharge the reactor coolant drain tank contents to the degasifier or to an effluent holdup tank. These vertical sump pumps have permanently lubricated bearings and mechanical seals. The pumps start and stop on high and low level.

Containment Sump Pumps

Two full-capacity containment sump pumps are provided. [These submersible pumps discharge the containment sump contents to the waste holdup tank.](#) The pumps start and stop on high and low level.

Degasifier Vacuum Pumps

Two stainless steel, full-capacity, liquid ring type, degasifier vacuum pumps maintain the degasifier at a low pressure for efficient gas stripping.

These liquid ring pumps use water as the compressant. The water is recycled to minimize consumption. Excess water from vapor condensation is discharged to an effluent holdup tank.

Degasifier Separator Pump

Two full capacity centrifugal pumps are provided to discharge recovered compressor water from the degasifier separator back to the degasifier vacuum pumps. The pump also serves to discharge any excess compressor water accumulation in the separator to an effluent holdup tank. The pumps start and stop to share the duty. The pump is constructed of stainless steel and has a mechanical seal.

Other Pumps

The following air-operated double-diaphragm pumps are mounted near the associated tanks with internal suction piping. Construction is of stainless steel, with elastomeric diaphragms.

- Degasifier discharge pumps (2)
- Effluent holdup tank pumps (2)
- Waste holdup tank pumps (2)
- Monitor tank pumps (6)
- Chemical waste tank pump (1)

11.2.2.3.2 Liquid Radwaste System Heat Exchangers

Reactor Coolant Drain Tank Heat Exchanger

One horizontal U-tube heat exchanger is provided. **The heat exchanger shell is removable to allow for inspection and cleaning of the tube bundles.**

The heat exchanger is designed to prevent the reactor coolant drain tank contents from boiling with hot leakage influent as shown in **Table 11.2-4**.

The reactor coolant drain tank contents flow through stainless steel tubes, and component cooling water flows inside a carbon or stainless steel shell.

Vapor Condenser

One horizontal U-tube heat exchanger assists in drying the gases drawn out of the liquid waste by the vacuum pump, before they are sent to the gaseous radwaste system. As the gas bearing water cascades down through the packing in the degasifier vessel, it boils in the low pressure. To minimize the size of the vacuum pumps, a vapor condenser is provided between the degasifier vessel and the vacuum pumps. In the vapor condenser, most of the water vapor is condensed out of the gas stream before it enters the vacuum pump. The vapor condenser is cooled by chilled water. Chilled water flows through the tubes, which are stainless steel. Water vapor condenses on the tubes and drains through a subcooling section in the stainless steel shell. The non-condensable gases and condensate are recombined in a common pipe leading to the suction of the liquid ring type vacuum pumps.

11.2.2.3.3 Liquid Radwaste System Tanks

Reactor Coolant Drain Tank

One reactor coolant drain tank is provided. The tank is sized to accommodate two vertical sump type pumps and to have a volume above the normal operating water level sufficient to accept the influent rate shown in **Table 11.2-4**.

The reactor coolant drain tank is a stainless steel, horizontal, cylindrical tank with dished heads. It is provided with a vacuum breaker to prevent excess external pressure during containment leak testing. It is protected from excess internal pressure by a relief valve which vents to the containment sump.

Effluent Holdup Tanks

These stainless steel tanks contain effluent waste prior to processing. They are horizontal cylinders with internal pump suction piping at the low point of the tank, and with side manways for maintenance.

Waste Holdup Tanks

These stainless steel tanks contain floor and equipment drain waste before processing. They are vertical cylinders with internal pump suction piping at the low points of the tanks and with side manways for maintenance.

Monitor Tanks

These stainless steel tanks contain processed waste before discharge. They are vertical cylinders with internal pump suction piping at the low points of the tanks and with side manways for maintenance.

Chemical Waste Tank

This stainless steel tank contains chemical waste along with detergent wastes from hot sinks, hot showers, and equipment decontamination before processing. The configuration is a vertical cylinder with internal pump suction piping at the low point of the tank and with a side manway for maintenance.

11.2.2.3.4 Liquid Radwaste System Sump

Containment Sump

The containment sump is a stainless steel, rectangular sump tank designed for embedment in concrete. The containment sump is sized as shown in [Table 11.2-4](#).

11.2.2.3.5 Liquid Radwaste System Vessels

Degasifier Column

A one-stage, stainless steel degasifier column is provided. The degasifier column is designed to meet the performance parameters shown in [Table 11.2-5](#).

Agitation and surface exposure are accomplished by spraying the influent onto the top of a column of packing which breaks up the flow and spreads it into thin films as it cascades downward. The low pressure causes the inlet water to boil. The flashed vapor accompanies the gas bearing water downward through the packing. Exposure to low pressure draws out the non-condensable gases consistent with Henry's Law and they pass out the vacuum connection. The vacuum connection is located near the last point of contact with the degassed water where the vacuum is greatest and conditions are least conducive to reabsorption. A stainless steel mesh demister is provided at the vessel vacuum connection to remove water droplets which are entrained in the gas/vapor mixture as it is exiting to the vapor condenser.

Degasifier Separator

One stainless steel separator is provided. It is designed to remove compressor water from the vacuum pump discharge flow for reuse. It also serves as a silencer.

11.2.2.3.6 Liquid Radwaste System Ion Exchangers

Four ion exchange vessels are provided, with resin volumes as shown in [Table 11.2-2](#). The media will be selected by the plant operator to optimize system performance. The ion exchange vessels are

stainless steel, vertical, cylindrical pressure vessels with inlet and outlet process nozzles plus connections for resin addition, sluicing, and draining. The process outlet and flush water outlet connections are equipped with resin retention screens designed to minimize pressure drop.

11.2.2.3.7 Liquid Radwaste System Filters

Waste Pre-Filter

This filter is provided to collect particulate matter in the process stream before ion exchange. The unit is constructed of stainless steel and has disposable filter bags.

Waste After-Filter

This filter is provided downstream of the ion exchangers to collect particulate matter, such as resin fines. The unit is constructed of stainless steel and has disposable filter cartridges.

11.2.2.4 Instrumentation Design

Instrumentation readout is available in the main control room and on display and control panels.

Alarms are provided to the data display system including a radwaste system annunciator in the main control room.

Pressure indicators provide pressure drops across demineralizers, filters, and strainers.

Releases to the environment are monitored for radioactivity. Section 11.5 describes this instrumentation.

Each tank is provided with level instrumentation that actuates an alarm on high liquid level in the tank, thus warning of potential tank overflow. High level in redundant tank pairs also diverts the flow to the standby tank. Table 11.2-3 provides a summary of the tank level alarms.

11.2.2.5 System Operation and Performance

11.2.2.5.1 Reactor Coolant System Effluent Processing

11.2.2.5.1.1 Reactor Coolant Systems Effluent: Letdown Line

Chemical and volume control system letdown is directed to the degasifier. This letdown flow automatically takes priority by causing isolation of influent to the degasifier from the reactor coolant drain tank pumps to prevent the design capacity of the degasifier from being exceeded.

When the degasifier and waste gas system are placed in operation one of the degasifier vacuum pumps operates to maintain a vacuum in the degasifier column. The degasifier separator pump operates to return compressor water to the vacuum pump. The degasifier separator vents to the gaseous radwaste system. Its level is automatically controlled by discharging excess water (due to condensation of vapor carryover from the degasifier column) to an effluent holdup tank. In the event of abnormally high level, chemical and volume control system letdown flow is automatically stopped.

Two effluent holdup tanks are provided. One is aligned to receive inputs. When it fills to the appropriate level, an alarm alerts the operator that the tank is full and ready for processing. The inlet diversion valve automatically realigns the system to route input to the other tank upon high-high alarm.

11.2.2.5.1.2 Reactor Coolant System Effluent: Reactor Coolant Drain Tank

The reactor coolant drain tank receives input from the reactor coolant system and other drains inside containment that have the potential to contain radioactive gas or hydrogen.

Initially and after servicing, the reactor coolant drain tank is filled with demineralized water and then purged with nitrogen to dilute and displace oxygen. The tank vent to the gaseous radwaste system normally remains closed. One of the reactor coolant drain tank pumps and the discharge valve are automatically controlled to maintain reactor coolant drain tank water level within a narrow band to minimize tank pressure variation. An alarm alerts the operator if the reactor coolant drain tank reaches a temperature consistent with the design leak of saturated RCS coolant. The system automatically realigns valves and recirculates the tank contents through the reactor coolant drain tank heat exchanger.

The cumulative quantity discharged from the reactor coolant drain tank is totaled and indicated for use in reactor coolant leakage evaluations.

The discharge may have a relatively high dissolved hydrogen concentration and is therefore aligned to the degasifier. However, during reactor coolant system loop drain operations the hydrogen and radioactive gas concentrations should be low and discharge may be directly aligned to an effluent holdup tank.

11.2.2.5.1.3 Processing of the Reactor Coolant System Effluents

Each effluent holdup tank vent includes a hydrogen detector to monitor the hydrogen concentration in the tank atmosphere. In the event of high alarm, the operator initiates air purge through the tank to dilute the hydrogen gas and maintain it below the flammable limits. The tanks vent to the radiologically controlled area ventilation system.

An effluent holdup tank high level alarm alerts the operator that the tank is full and ready for processing. The inlet diversion valve automatically directs the influent to the other tank upon high-high alarm.

To process the contents of the filled tank, the effluent holdup tank pump is started to recirculate and sample the tank contents. If additional gas stripping is required, the tank contents may be recirculated through the degasifier. The degasifier functions automatically as described in [Subsection 11.2.2.5.1.1](#).

The discharge of either effluent holdup tank pump can be aligned to the suction of the chemical and volume control system makeup pumps. This mode of operation is used during reactor coolant system degassing operations. Reactor coolant from the chemical and volume control system letdown is degassed in the degasifier, collected in one of the effluent holdup tanks, and continuously pumped back to the chemical and volume control system makeup pumps. The pump returns the degassed water to the reactor coolant system.

Reactor coolant collected in an effluent holdup tank during reactor coolant system loop drain operations may also be pumped to the chemical and volume control system makeup pumps for refill of the reactor coolant system. Before beginning this process, the operator fully drains the effluent holdup tank receiving the reactor coolant so that the boron concentration of the reactor coolant system is not significantly affected.

The effluent may be transferred to the mobile treatment facility for concentration or solidification. This disposal method is used only during unusual conditions that restrict the normal processed waste discharge mode described in the following paragraphs.

The normal mode of operation is to process the effluent by ion exchange and filtration to remove the radioactive materials. The ion exchangers operate in series as described in [Subsection 11.2.2.1.1](#).

The last bed provides a polishing function and also prevents radioactivity breakthrough to the monitor tank when the upstream unit becomes exhausted. This allows the full capacity of the upstream resin beds to be used, reducing the amount of spent resin that is generated.

When the analysis of samples taken periodically downstream of the ion exchange processing indicates an increase in radioactivity above prescribed limits, the operator isolates the expended unit(s) for resin replacement. Flow continues through the other units until a fresh resin bed is ready. When one of the last two ion exchangers has been replenished, the fresh unit is then brought online as the downstream unit.

The after-filter removes resin fines and other particulate matter that may pass through the ion exchangers. A high differential pressure alarm alerts the operator to the need for filter element replacement. Normally, filter element replacement is initiated on high radioactivity determined by periodic survey.

Process discharge is normally aligned to one of the monitor tanks. When one of the tanks is full, an alarm alerts the operator that the tank is full and ready to be discharged. The inlet diversion valve automatically realigns the system to route processed waste to another tank upon high-high level.

The operator then starts the monitor tank pump to recirculate the tank contents and samples the processed waste. Since the ion exchangers operate in the borated saturated mode, the water contains boric acid. The radioactivity and chemistry of the processed waste is determined by sample analysis. In the unlikely event that radioactivity exceeds discharge limitations, the tank contents are returned to a waste holdup tank for reprocessing.

Once it is confirmed that the waste water is within radioactivity discharge limitations, the operator prepares the system for discharge. The operator initiates discharge by starting the monitor tank pump and opening the remotely operated discharge valve. During controlled discharge, grab samples are taken for laboratory analysis and documentation of discharge.

If the radiation monitor in the discharge line detects high radiation, the valve automatically closes. The operator is alerted to this condition by a high radiation alarm, and is required to take corrective action. A manual drain valve is opened to flush the radiation monitor and confirm low radiation before re-establishing discharge to the circulating water blowdown. Low monitor tank level automatically stops the monitor tank pump.

11.2.2.5.2 Floor Drain and Equipment Drain Waste Processing

Miscellaneous liquid wastes normally include influent from the radioactive floor drains, equipment drains and auxiliary building sump and excess water from the solid radwaste system. These wastes collect in one of two waste holdup tanks.

A high level alarm in the tank alerts the operator that the tank is full and ready to be processed. The inlet diversion valve automatically directs influents to the second waste holdup tank upon high-high level. The waste holdup tank pump is started to recirculate and sample the tank contents. Additives may be introduced to the waste holdup tank to optimize filtration and ion exchange processes.

Floor drain wastes are also brought into the waste holdup tanks from the containment sump. High sump level automatically opens the containment isolation valves and starts a pump to transfer the sump contents. Low level automatically stops the pump and closes the isolation valves. An alarm is provided to alert the operator to abnormally high containment sump level and the standby pump is

automatically started. Cumulative flow is totalized and indicated to support reactor coolant leakage analysis.

The normal mode of operation is to process the waste water through the pre-filter, ion exchangers, and after-filter to the monitoring tank as described for the reactor coolant system effluent processing. Under abnormal conditions, the waste may also be transferred directly to a mobile treatment facility.

11.2.2.5.3 Detergent Waste Processing

The detergent wastes from the plant hot sinks and showers are routed to the chemical waste tank. Normally, these wastes are sampled and confirmed suitable for discharge without processing. If processing prior to discharge is necessary, three courses of action are available. The waste water may be transferred to a waste holdup tank and processed in the same manner as other radioactively contaminated waste water. If the onsite processing capabilities are not suitable for the composition of the detergent waste, processing can be performed using mobile equipment brought into one of the truck bays of the radwaste building or the waste water can be shipped offsite for processing. After processing by mobile equipment the water may be transferred to a waste holdup tank for further processing by the onsite equipment or transferred to a monitor tank for sampling and discharge.

11.2.2.5.4 Chemical Waste Processing

Radioactively contaminated chemical wastes are collected in the chemical waste tank. Chemicals may be added to the tank for pH or other adjustment. The volume of these wastes is expected to be low. The design includes alternatives for processing or discharge of chemical wastes. They may be processed onsite without being combined with other wastes using mobile equipment. When combined with detergent wastes, they may be suitable for discharge without treatment or for processing by onsite equipment before discharge. When not suitable for onsite processing, they can be treated using mobile equipment or shipped offsite for processing. After processing by mobile equipment the water may be transferred to a waste holdup tank for further processing by the onsite equipment or transferred to a monitor tank for sampling and discharge.

11.2.2.5.5 Steam Generator Blowdown Processing

Normal steam generator blowdown processing is accommodated by the steam generator blowdown system, which is described in [Subsection 10.4.8](#).

If steam generator tube leakage results in levels of radioactivity in the blowdown stream above what can be accommodated by the secondary-side systems, this stream is directed to the liquid radwaste system. For this function, the operator aligns the steam generator blowdown system to the inlet of the waste holdup tank. The blowdown waste is then processed in the same way as other wastes.

11.2.2.5.6 Ion Exchange Media Replacement

The initial and subsequent fill of ion exchange media is made through a resin fill nozzle on the top of the ion exchange vessel. When the media are spent and ready to be transferred to the solid radwaste system, the vessel is isolated from the process flow. The flush water line is opened to the sluice piping and demineralized water is pumped into the vessel through the normal process outlet connection upward through the media retention screen. The media fluidize in the upward, reverse flow. When the bed has been fluidized, the sluice connection is opened and the bed is sluiced to the spent resin tanks in the solid radwaste system (WSS). Demineralized water flow continues until the bed has been removed and the sluice lines are flushed clean of spent resin.

11.2.3 Radioactive Releases

Liquid waste is produced both on the primary side (primarily from adjustment of reactor coolant boron concentration and from reactor coolant leakage) and the secondary side (primarily from steam generator blowdown processing and from secondary side leakage). Primary and secondary coolant activity levels are provided in [Section 11.1](#) for both the design case and the anticipated case, which is based on operating plant experience.

Except for reactor coolant system degasification in anticipation of shutdown, the AP1000 does not recycle primary side effluents for reuse. Primary effluents are discharged to the environment after processing. Fluid recycling is provided for the steam generator blowdown fluid which is normally returned to the condensate system.

The only liquid effluent site interface parameter outside of the Westinghouse scope is the release point to the Savannah River.

11.2.3.1 Discharge Requirements

The release of radioactive liquid effluents from the plant may not exceed the concentration limits specified in [Reference 1](#) nor may the releases result in the annual offsite dose limits specified in 10 CFR 50, Appendix I ([Reference 2](#)) being exceeded.

11.2.3.2 Estimated Annual Releases

The annual average release of radionuclides from the plant is determined using the PWR-GALE code ([Reference 3](#)). The PWR-GALE code models releases which use source terms derived from data obtained from the experience of operating PWRs. The code input parameters used in the analysis to model the AP1000 plant are listed in [Table 11.2-6](#). The annual releases for a single-unit site are presented in [Table 11.2-7](#).

In agreement with [Reference 3](#), the total releases include an adjustment factor of 0.16 curies per year to account for anticipated operational occurrences. The adjustment uses the same distribution of nuclides as the calculated releases.

11.2.3.3 Dilution Factor

The dilution factor provided for the activity released is site dependent; the value of 6000 gpm used herein is based on cooling tower blowdown requirements and is expected to be conservatively low. The plant operator will select dilution flow rates to ensure that the effluent concentration limits of 10 CFR Part 20, the annual offsite dose limits in 10 CFR 50 Appendix I, and any local requirements are continuously met. If the available dilution is low, the discharge rate can be reduced to maintain acceptable concentrations.

The required dilution flow is dependent on the liquid waste discharge rate and, while the monitor tank pumps have a design flow rate of 100 gpm, the discharge flow is controlled to be compatible with the available dilution flow. With a typical liquid waste release of 1925 gallons per day, the nominal circulating water blowdown flow of 6000 gpm provides sufficient dilution flow to maintain the annual average discharge concentrations well below the effluent concentration limits. Actual plant operation is dependent on the waste liquid activity level and the available dilution flow.

The site-specific dilution factor is addressed in [Subsection 11.2.3.5](#).

11.2.3.4 Release Concentrations

The annual release data provided in [Table 11.2-7](#) represent expected releases from the plant. To demonstrate compliance with the [Reference 1](#) effluent concentration limits, the discharge concentrations have been evaluated for the release of a typical daily liquid waste volume of 1925 gallons per day and using the nominal circulating water blowdown flow of 6000 gpm.

[Table 11.2-8](#) lists the annual average nuclide release concentrations and the fraction of the effluent concentration limits using base GALE code assumptions. As shown in [Table 11.2-8](#), the overall fraction of the effluent concentration limit is 0.11, which is well below the allowable value of 1.0.

The annual releases from the plant have also been evaluated based on operation with the maximum defined fuel defect level. The maximum defined fuel defect level corresponds to the Technical Specification limit on coolant activity which is based on 0.25 percent fuel defects. [Table 11.2-9](#) lists the annual average nuclide release concentrations and the fractions of the effluent concentration limits for the maximum defined fuel defects. As shown in [Table 11.2-9](#), the overall fraction of the effluent concentration limit for the maximum defined fuel defect level is 0.53, which is well below the allowable value of 1.0.

11.2.3.5 Estimated Doses

11.2.3.5.1 Exposure Pathways

Small quantities of radioactive liquids would be discharged to the Savannah River during normal operation of the new units. VEGP Units 3 and 4 discharge structure and associated piping provide a pathway for liquid effluents, including radioactive liquids, discharged to the Savannah River. The impact of these releases on individuals and the population in the vicinity of the new units is evaluated by considering the most important pathways from the release to the receptors of interest. The major pathways are those that could yield the highest radiological doses for a given receptor. The relative importance of a pathway is based on the type and amount of radioactivity released, the environmental transport mechanism, and the consumption or usage factors at the receptor.

The exposure pathways considered and the analytical methods used to estimate doses to the maximally exposed individual (MEI) and to the population surrounding the new units are based on NRC Regulatory Guide 1.109, *Calculation of Annual Doses to Man from Routine Releases of Reactor Effluents for the Purpose of Evaluating Compliance with 10 CFR 50, Appendix I*, Revision 1, October 1977. An MEI is a member of the public located to receive the maximum possible calculated dose. The MEI allows dose comparisons with established criteria for the public.

Liquid effluent releases would be to Savannah River. The discharge is assumed to be fully mixed with the river flow. The NRC-endorsed LADTAP II computer program ([Reference 203](#)) is used to calculate liquid effluent doses, with parameters specific to the river and downstream locations. This program implements the radiological exposure models described in Regulatory Guide 1.109 for radioactivity releases in liquid effluent. The following exposure pathways are considered in LADTAP II in calculating MEI and population doses:

- Ingestion of aquatic foods
- Ingestion of drinking water
- External exposure to shoreline sediments
- External exposure to water through boating and swimming

The input parameters for the liquid pathway are presented in [Tables 11.2-201, 11.2-202, and 11.2-203](#).

11.2.3.5.2 Liquid Pathway Doses

Based on the parameters shown in [Tables 11.2-201, 11.2-202, and 11.2-203](#), the LADTAP II computer program is used to calculate doses to the MEI and the population via the following activities:

- Eating fish caught in Savannah River
- Drinking water from Savannah River
- Boating, swimming, and using the shoreline for recreational purposes

The liquid activity releases (source terms) for the two proposed AP1000 units are obtained from [Table 11.2-7 \(Reference 207\)](#) and are shown in [Table 11.2-203](#). These are conservative, projected values that were calculated using the PWR-GALE computer code ([Reference 202](#)). [Table 11.2-203](#) also shows the maximum measured activity releases for Units 1 and 2, based on information presented in the annual effluent reports ([References 204, 205, 206](#)). Projected activity concentrations in Savannah River are based on the calculated activity releases for Units 3 and 4 as well as the measured activity releases from Units 1 and 2. The concentrations are within the limits of 10 CFR 20, Appendix B, Table 2, Column 2. The calculated annual doses to the MEI are presented in [Table 11.2-204](#). The maximum annual organ dose of 0.021 mrem per unit would be received by the liver of the maximally exposed child.

[Table 11.2-205](#) shows that the doses to the MEI from the liquid effluents of a new unit meet the design objectives of 10 CFR 50, Appendix I. The total site doses due to liquid and gaseous effluents from the two existing units and the two new units would be well within the regulatory limits of 40 CFR 190, as shown in [Table 11.2-206](#). Since 40 CFR 190 is more restrictive than 10 CFR 20.1301, compliance with the limits of 40 CFR 190 also demonstrates compliance with the 0.1 rem limit of 10 CFR 20.1301. [Table 11.2-207](#) shows the doses from the new and existing units to the population within 50 miles of the ESP site. The doses from the proposed units are much higher than from the existing units because doses from the existing units are more realistic, based on measurements, whereas the doses from the proposed units are based on conservative calculations.

[Table 11.2-207](#) reports a total body population dose from liquid effluents within 50 miles of VEGP Units 3 and 4 of 0.037 person-rem/year or 0.019 person-rem/year per reactor. In addition, the corresponding thyroid dose has been calculated to be 0.0022 person-rem/year per reactor.

11.2.3.5.3 Liquid Radwaste Cost Benefit Analysis Methodology

The application of the methodology of Regulatory Guide 1.110 was used to satisfy the cost benefit analysis requirements of 10 CFR Part 50, Appendix I, Section II.D. The parameters used in calculating the Total Annual Cost (TAC) are fixed and are given for each radwaste treatment system augment listed in Regulatory Guide 1.110, including the Annual Operating Cost (AOC) ([Table A-2](#)), Annual Maintenance Cost (AMC) ([Table A-3](#)), Direct Cost of Equipment and Materials (DCEM) ([Table A-1](#)), and Direct Labor Cost (DLC) ([Table A-1](#)). The following variable parameters were used:

- Capital Recovery Factor (CRF) -This factor is taken from [Table A-6](#) of Regulatory Guide 1.110 and reflects the cost of money for capital expenditures. A cost-of-money value of 7% per year is assumed in this analysis, consistent with the "Regulatory Analysis Guidelines of the U.S. Nuclear Regulatory Commission" (NUREG/BR-0058). A CRF of 0.0806 was obtained from [Table A-6](#).

- Indirect Cost Factor (ICF) -This factor takes into account whether the radwaste system is unitized or shared (in the case of a multi-unit site) and is taken from Table A-5 of Regulatory Guide 1.110. It is assumed that the radwaste system for this analysis is a unitized system at a 2-unit site, which equals an ICF of 1.625.
- Labor Cost Correction Factor (LCCF) -This factor takes into account the differences in relative labor costs between geographical regions and is taken from Table A-4 of Regulatory Guide 1.110. A LCCF of 1.0 (the lowest value) is assumed in this analysis.

Appendix I to 10 CFR Part 50 prescribes a \$1,000 per person-rem criterion for determining the cost benefit of actions to reduce radiation exposure.

The analysis used a conservative assumption that the respective radwaste treatment system augment is a "perfect" system that reduces the effluent and dose by 100 percent. The liquid radwaste treatment system augments annual costs were determined and the lowest annual cost considered a threshold value. The lowest-cost option for liquid radwaste treatment system augments is a 20 gpm Cartridge Filter at \$11,140 per year, which yields a threshold value of 11.14 person-rem total body or thyroid dose from liquid effluents.

For AP1000 sites with population dose estimates less than 11.14 person-rem total body or thyroid dose from liquid effluents, no further cost-benefit analysis is needed to demonstrate compliance with 10 CFR 50, Appendix I Section II.D.

11.2.3.5.4 Liquid Radwaste Cost Benefit Analysis

As discussed in [Subsection 11.2.3.5.3](#), the lowest cost liquid radwaste system augment is \$11,140. Assuming 100% efficiency of this augment, the minimum possible cost per person-rem is determined by dividing the cost of the augment by the population dose. This is \$586,316 per person-rem total body ($\$11,140/0.019$ person-rem) and \$5,063,636 per person-rem thyroid ($\$11,140/0.0022$ person-rem). These costs per person-rem reduction exceed the \$1,000 per person-rem criterion prescribed in Appendix I to 10 CFR Part 50 and are therefore not beneficial.

11.2.3.6 Quality Assurance

The quality assurance program for design, fabrication, procurement, and installation of the liquid radwaste system is in accordance with the overall quality assurance program described in [Chapter 17](#).

Since the impact of radwaste systems on safety is limited, the extent of control required by Appendix B to 10 CFR Part 50 is similarly limited. Thus, a supplemental quality assurance program applicable to design, construction, installation and testing provisions of the liquid radwaste system is established by procedures that complies with the guidance presented in Regulatory Guide 1.143.

11.2.4 Preoperational Testing

11.2.4.1 Sump Level Instrument Testing

One of the diverse methods of detecting small reactor coolant pressure boundary leaks is monitoring the containment sump level. (See [Subsection 5.2.5](#) for a full discussion.) A sump capacity calibration test is performed so the containment sump level instruments can provide a display that is correlated to the contained volume of water in the sump.

In addition to a normal level accuracy calibration of the containment sump level instruments, WLS-LT-034 and WLS-LT-035, their displays will be correlated to the volume of water during preoperational

testing. A known volume of water will be added to the containment sump. The change in sump level will be measured by marking the sump wall before and after the addition of water. The change in the display of the sump level instruments will be compared to the level change measured on the sump wall. A sump level change corresponding to a volume of water which is smaller than that released in an hour by 0.5 gpm reactor coolant system leak can be detected.

11.2.4.2 Discharge Control/Isolation Valve Testing

The AP1000 effluent discharge line includes a radiation monitor, WLS-RE-229, as described in [Subsection 11.5.2.3.3](#). A concentration of radioactivity in the effluent, which exceeds the radiation monitor setpoint, causes a high radiation signal to automatically close the discharge control/isolation valve.

A test will be performed on the liquid radwaste system discharge control/isolation valve, WLS-PL-V223, during preoperational testing. A simulated WLS-RE-229 high radiation signal will be sent to the plant control system and the discharge control/isolation valve will be observed to close.

11.2.4.3 Preoperational Inspection

The performance of the liquid radwaste system has been evaluated based upon using a predetermined quantity and type of ion-exchange media. An inspection will confirm that the proper volume of media, as listed in [Table 11.2-2](#), "Component Data – Liquid Radwaste System," has been installed into the appropriate liquid radwaste system components, MV03 and MV04A/B/C.

11.2.5 Combined License Information

11.2.5.1 Liquid Radwaste Processing by Mobile Equipment

The mobile or temporary equipment used for storing or processing liquid radwaste is addressed in [Subsection 11.2.1.2.5.2](#).

11.2.5.2 Cost Benefit Analysis of Population Doses

The site specific cost-benefit analysis to address the requirements of 10 CFR 50, Appendix I, regarding population doses due to liquid effluents is addressed in [Subsections 11.2.3.3, 11.2.3.5, 11.2.3.5.3 and 11.2.3.5.4](#).

11.2.5.3 Identification of Ion Exchange and Adsorbent Media

The types of liquid waste ion exchange and adsorbent media to be used in the liquid radwaste system (WLS) are addressed in APP-GW-GLR-008 ([Reference 6](#)).

11.2.5.4 Dilution and Control of Boric Acid Discharge

The planned discharge flow rate for borated wastes and controls for limiting the boric acid concentration in the circulating water system blowdown is addressed in APP-GW-GLR-014 ([Reference 7](#)).

11.2.6 References

1. "Annual Limits on Intake (ALIs) and Derived Air Concentrations (DACs) of Radionuclides for Occupational Exposure; Effluent Concentrations; Concentrations for Release to Sewerage," 10 CFR Part 20, Appendix B, Issued by 58 FR 67657, April 28, 1995.

-
2. "Numerical Guides for Design Objectives and Limiting Conditions for Operation to Meet the Criterion 'As Low As Is Reasonably Achievable' for Radioactive Material in Light-Water-Cooled Nuclear Power Reactor Effluents," 10 CFR Part 50, Appendix I.
 3. "Calculation of Releases of Radioactive Materials in Gaseous and Liquid Effluents from Pressurized Water Reactors (PWR-GALE Code)," NUREG-0017, Revision 1, March 1985.
 4. ANSI/ANS-55.6-1993, "Liquid Radioactive Waste Processing Systems for Light Water Reactor Plants."
 5. "Minimization of Contamination," 10 CFR 20.1406.
 6. APP-GW-GLR-008, "Identification of Ion Exchange and Absorbent Media, Completing COL Items 11.2-3 and 11.3-2," Westinghouse Electric Company LLC.
 7. APP-GW-GLR-014, "Closure of COL Items in DCD Chapter 11, Dilution and Control of Boric Acid Discharge," Westinghouse Electric Company LLC.
 8. "Appendix A to Part 71 – Determination of A_1 and A_2 ," 10 CFR 71 Appendix A, Table A-1.
 201. [NEI 08-08A, Generic FSAR Template Guidance for Life Cycle Minimization of Contamination, Revision 0, October 2009 \(ML093220445\)](#).
 202. **(NRC 1985)** NUREG-0017, *Calculation of Releases of Radioactive Materials in Gaseous and Liquid Effluents from Pressurized Water Reactors (PWR-GALE Code)*, Revision 1, U. S. Nuclear Regulatory Commission, 1985.
 203. **(NRC 1986)** NUREG/CR-4013, *LADTAP II Technical Reference and User Guide*, U. S. Nuclear Regulatory Commission, 1986.
 204. **(SNC 2002)** *Annual Radioactive Effluent Release Report for January 1, 2001 to December 31, 2001*, Southern Nuclear Company, 2002.
 205. **(SNC 2003)** *Annual Radioactive Effluent Release Report for January 1, 2002 to December 31, 2002*, Southern Nuclear Company, 2003.
 206. **(SNC 2004)** *Annual Radioactive Effluent Release Report for January 1, 2003 to December 31, 2003*, Southern Nuclear Company, 2004.
 207. **(Westinghouse 2005)** AP1000 Document APP-GW-GL-700, *AP1000 Design Control Document, Tier 2 Material*, Revision 15, Westinghouse Electric Company, 2005.
 208. **(WSRC 2006)** WSRC-TR-2006-00007, *Savannah River Site Environmental Report for 2005*, Washington Savannah River Company, 2006. Accessed from http://www.srs.gov/general/pubs/ERsum/er06/liqdos_05.htm, April 18, 2007.

**Table 11.2-1 (Sheet 1 of 2)
Liquid Inputs and Disposition**

Collection Tank and Sources	Expected Input Rate	Activity	Basis	Disposition
1. Effluent holdup tanks				Filtered, demineralized, and discharged
Chemical and volume control system letdown	159,000 gpy	100% of reactor coolant	AP1000-specific calculations ^(b)	
Leakage inside containment (to reactor coolant drain tank)	10 gpd	167% of reactor coolant	ANSI/ANS-55.6	
Leakage outside containment (to effluent holdup tanks)	80 gpd	100% of reactor coolant	ANSI/ANS-55.6	
Sampling drains	200 gpd	100% of reactor coolant	ANSI/ANS-55.6 ^(a)	
2. Waste holdup tank				Filtered, demineralized and discharged
Reactor containment cooling	500 gpd	0.1% of reactor coolant	ANSI/ANS-55.6	
Spent fuel pool liner leakage	25 gpd	0.1% of reactor coolant	ANSI/ANS-55.6	
Misc. drains	675 gpd	0.1% of reactor coolant	ANSI/ANS-55.6	

**Table 11.2-1 (Sheet 2 of 2)
Liquid Inputs and Disposition**

Collection Tank and Sources	Expected Input Rate	Activity	Basis	Disposition
3. Detergent waste				Filtered, monitored, and discharged. If necessary, processed with mobile equipment.
Hot shower	0 gpd	10^{-7} $\mu\text{Ci/g}$	ANSI/ANS-55.6	
Hand wash	200 gpd	10^{-7} $\mu\text{Ci/g}$	ANSI/ANS-55.6	
Equipment and area decontamination	40 gpd	0.1% of reactor coolant	ANSI/ANS-55.6	
Laundry			Offsite laundry	
4. Chemical wastes	2 gpd	\leq reactor coolant	Estimate	Processed with mobile equipment

Notes:

- a. ANSI/ANS-55.6 identifies sampling drains activity of 5 percent of reactor coolant; 100 percent is used as a conservative input for GALE Code analysis.
- b. Average letdown for all normal reactor fuel cycle operations; initial heatup, dilutions and borations.

**Table 11.2-2 (Sheet 1 of 7)
Component Data – Liquid Radwaste System**

Pumps	
Containment sump pumps	
Number	2
Type	Submersible centrifugal
Design pressure (psig)	32.5 external
Design temperature (°F)	250
Design flow (gpm)	100
Material	Stainless steel
Reactor coolant drain tank pumps	
Number	2
Type	Vertical sump type, centrifugal
Design pressure (psig)	10 external
Design temperature (°F)	250
Design flow (gpm)	100
Material	Stainless steel
Degasifier separator pump (part of vacuum degasifier)	
Number	2
Type	Centrifugal
Design pressure (psig)	212
Design temperature (°F)	150
Design flow (gpm)	7
Material	Stainless steel

**Table 11.2-2 (Sheet 2 of 7)
Component Data – Liquid Radwaste System**

Pumps	
Standard waste processing pump	
Standard waste processing pump used for: ⁽¹⁾	
<u>Number</u>	<u>Application</u>
2	Degasifier discharge pumps
2	Effluent holdup tank pumps
2	Waste holdup tank pumps
6	Monitor tank pumps
1	Chemical waste tank pump
Type	Air-operated, double-diaphragm
Design pressure (psig)	125
Design temperature (°F)	150
Design flow (gpm)	100 (can be varied by varying air supply flow)
Material	Stainless steel body, Elastomeric diaphragm
Degasifier vacuum pumps (part of vacuum degasifier package)	
Number	2
Type	Liquid ring
Design pressure (psig)	125
Design temperature (°F)	150
Design flow (scfm) (total hydrogen and water vapor flow)	641
Material	Stainless steel

**Table 11.2-2 (Sheet 3 of 7)
Component Data – Liquid Radwaste System**

Filters	
Waste pre-filter	
Number	1
Type	Disposable bag
Design pressure (psig)	150
Design temperature (°F)	150
Design flow (gpm)	75
Particle size (micron, 98% retention)	25
Materials	
Housing	Stainless steel
Filter	Polypropylene/pleated paper
Waste after-filter	
Number	1
Type	Disposable bag or cartridge
Design pressure (psig)	150
Design temperature (°F)	150
Design flow (gpm)	75
Particle size (micron, 98% retention)	0.5
Materials	
Housing	Stainless steel
Filter medium	Polypropylene/pleated paper

**Table 11.2-2 (Sheet 4 of 7)
Component Data – Liquid Radwaste System**

Heat Exchangers	
Reactor Coolant drain tank heat exchanger	
Number	1
Type	Horizontal U-tube
Design pressure (psig)	200 tubeside, 200 shellside
Design temperature (°F)	250 tubeside, 200 shellside
Design flow (lb/hr)	48,700 tubeside, 62,200 shellside
Heat Transfer Design Case	
Temperature inlet (°F)	175 tubeside, 95 shellside
Temperature outlet (°F)	143 tubeside, 120 shellside
Material	SS tubeside, CS or SS shellside
Vapor condenser	
Number	1
Type	Horizontal U-tube
Design pressure (psig)	150
Design temperature (°F)	150
Design flow (lb/hr)	125,000 tubeside, 1800 shellside
Heat Transfer Design Case	
Temperature inlet (°F)	40 tubeside, 87.1 shellside
Temperature outlet (°F)	55.7 tubeside, 60 shellside
Material	SS

Table 11.2-2 (Sheet 5 of 7)
Component Data – Liquid Radwaste System

Ion Exchangers	
Deep bed filter	
Number	1
Design pressure (psig)	150
Design temperature (°F)	150
Design flow (gpm)	75
Nominal resin volume (ft ³)	50
Material	Stainless steel
Resin type	Layered: Activated charcoal on zeolite resin (Adjustable for plant conditions)
Process decontamination factors	See Table 11.2-5
Waste ion exchangers	
Number	3
Design pressure (psig)	150
Design temperature (°F)	150
Design flow (gpm)	75
Nominal resin volume (ft ³)	30
Materials	Stainless steel
Resin type	One cation, Two mixed (Adjustable for plant conditions)
Process decontamination factors	See Table 11.2-5

**Table 11.2-2 (Sheet 6 of 7)
Component Data – Liquid Radwaste System**

Tanks	
Reactor coolant drain tank	
Number	1
Nominal volume (gal)	900
Type	Horizontal
Design pressure (psig)	internal — 20 for the tank and 10 for the valves and attached instruments external pressure range — -0.2 to 1.0
Material	Stainless steel
Containment sump	
Number	1
Nominal volume (gal)	220
Type	Rectangular
Design pressure (psig)	Atmospheric
Design temperature (°F)	200
Material	Stainless steel
Effluent holdup tanks	
Number	2
Nominal volume (gal)	28,000
Type	Horizontal
Design pressure (psig)	Atmospheric
Design temperature (°F)	150
Material	Stainless steel
Waste holdup tanks	
Number	2
Nominal volume (gal)	15,000
Type	Vertical
Design pressure (psig)	Atmospheric
Design temperature (°F)	150
Material	Stainless steel

**Table 11.2-2 (Sheet 7 of 7)
Component Data – Liquid Radwaste System**

Monitor tanks	
Number	6
Nominal volume (gal)	15,000
Type	Vertical
Design pressure (psig)	Atmospheric
Design temperature (°F)	150
Material	Stainless steel
Chemical waste tank	
Number	1
Nominal volume (gal)	7,700
Type	Vertical
Design pressure (psig)	Atmospheric
Design temperature (°F)	150
Material	Stainless steel
Degasifier separator (part of vacuum degasifier package)	
Number	1
Nominal volume (gal)	45
Type	Vertical
Design pressure (psig)	75
Design temperature (°F)	200
Material	Stainless steel
Degasifier column (part of vacuum degasifier package)	
Number	1
Nominal volume (gal)	900
Type	Vertical
Design pressure (psig)	75 internal 15 external
Design temperature (°F)	150
Material	Stainless steel

Note:

1. This same pump is also used for other applications, such as sumps outside containment.

**Table 11.2-3
Summary of Tank Level Indication, Level Annunciators, and Overflows**

Tank	Level Indication Location (Note 3)	Alarm Location	Alarm	Overflow To
Effluent holdup	MCR	MCR	High	Room drains to auxiliary building sump which is pumped to waste holdup tank (Note 2)
Waste holdup	MCR	MCR	High	Room (Note 4)
Chemical waste	MCR	MCR	High	Room (Note 2)
Monitor	MCR	MCR	High	Room (Note 5)

Notes:

1. MCR = main control room
2. Room is piped to a floor drain within the auxiliary building, which is seismic Category I and water-tight with curbs or walls of sufficient height to contain the entire contents of the contained tank.
3. Monitoring of the liquid radwaste system is performed through the data display and processing system. Control functions are performed by the plant control system. Appropriate alarms and displays are available in the control room. *Local indication and control are available on displays which may be connected to the data display and processing system.* See Chapter 7.
4. Room is within the auxiliary building, which is seismic Category I and water-tight with curbs or walls of sufficient height to contain the entire contents of the contained tank.
5. Room is piped to a floor drain within the auxiliary building, which is seismic Category I and water-tight with curbs or walls of sufficient height to contain the entire contents of the contained tank, or to a floor drain within the radwaste building, which is water tight with curbs or walls of sufficient height to contain the entire contents of the contained tank.

**Table 11.2-4
Tank Surge Capacity**

<p>Reactor Coolant Drain Tank</p> <ul style="list-style-type: none">• Sized to accept 10 gpm of saturated reactor coolant for 1 hour without discharge or overflow.• Reactor coolant drain tank heat exchanger designed to limit the temperature to less than 175°F with this input assumed to be at 580°F.
<p>Containment Sump</p> <ul style="list-style-type: none">• Sized to allow collection of 60 gallons of water between pumping cycles.
<p>Effluent Holdup Tanks</p> <ul style="list-style-type: none">• Sized to allow (together) a back-to-back plant shutdown and restart without delay at any time during the first 85 percent of core life. This operation requires nominal processing of the effluent monitor tanks and normal discharge with temporary storage of waste fluid in the cask loading pit.• Sized to allow (together) a single plant shutdown and restart without delay at any time during the first 80 percent of core life. This operation requires nominal processing to the monitor tanks, but no discharge from the plant.
<p>Other Tanks</p> <ul style="list-style-type: none">• Sized based on accommodating maximum input without operator intervention for reasonable lengths of time.

**Table 11.2-5
Decontamination Factors**

Decontamination factors assumed per NUREG-0017, Revision 1 (PWR-GALE code input) to be as follows:			
Resin Type/Component	Iodine	Cs/Rb	Other
Zeolite/deep bed filter (Note 1)	1	100	1
Cation/waste ion exchanger 1	1	10	10
Mixed/waste ion exchanger 2	100	2 (Note 2)	100
Mixed/waste ion exchanger 3	10	10 (Note 2)	10 (Note 2)

Other components not directly involved in discharge from the plant:

- Degasifier Column
- Reduce hydrogen by a factor of 40
- Assuming inlet flow of 100 gpm at 130°F.

Notes:

1. This component is not included in NUREG-0017. DFs based upon "Reduction of Cesium and Cobalt Activity in Liquid Radwaste Processing Using Clinoptilolite Zeolite at Duke Power Company," by O.E. Ekechokwu, et al., Proc. Waste Management '92, Tucson, Arizona, March 1992, University of Arizona, Tucson.
2. Credit for this decontamination factor not taken in determination of anticipated annual releases.

**Table 11.2-6 (Sheet 1 of 3)
Input Parameters for the GALE Computer Code**

Thermal power level (MWt)	3400
Mass of primary coolant (lb)	4.35×10^5
Primary system letdown rate (gpm)	100
Letdown cation demineralizer flow rate, annual average (gpm)	10
Number of steam generators	2
Total steam flow (lb/hr)	14.97×10^6
Mass of liquid in each steam generator (lb)	1.75×10^5
Total blowdown rate (lb/hr)	4.2×10^4
Blowdown treatment method	0 ⁽¹⁾
Condensate demineralizer regeneration time	N/A
Condensate demineralizer flow fraction	0.33
Primary coolant bleed for boron control	
Bleed flow rate (gpd)	435
Decontamination factor for I	10^3
Decontamination factor for Cs and Rb	10^3
Decontamination factor for others	10^3
Collection time (day)	30
Process and discharge time (day)	0
Fraction discharged	1.0
Equipment Drains and Clean Waste	
Equipment drains flow rate (gpd)	290
Fraction of reactor coolant activity	1.023
Decontamination factor for I	10^3
Decontamination factor for Cs and Rb	10^3
Decontamination factor for others	10^3
Collection time (day)	30
Process and discharge time (day)	0
Fraction discharged	1.0

Table 11.2-6 (Sheet 2 of 3)
Input Parameters for the GALE Computer Code

Dirty Waste	
Dirty waste input flow rate (gpd)	1200
Fraction of reactor coolant activity	0.001
Decontamination factor for I	10^3
Decontamination factor for Cs and Rb	10^3
Decontamination factor for others	10^3
Collection time (day)	10
Process and discharge time (day)	0
Fraction discharged	1.0
Blowdown Waste	
Blowdown fraction processed	1
Decontamination factor for I	100
Decontamination factor for Cs and Rb	10
Decontamination factor for others	100
Collection time	N/A
Process and discharge time	N/A
Fraction discharged	0
Regenerant Waste	N/A

**Table 11.2-6 (Sheet 3 of 3)
Input Parameters for the GALE Computer Code**

Gaseous Waste System	
Continuous gas stripping of full letdown purification flow	None
Holdup time for xenon, (days)	38
Holdup time for krypton, (days)	2
Fill time of decay tanks for gas stripper	N/A
Gas waste system: HEPA filter	None
Auxiliary building: Charcoal filter	None
Auxiliary building: HEPA filter	None
Containment volume (ft ³)	2.1 x 10 ⁶
Containment atmosphere internal cleanup rate (ft ³ /min)	N/A
Containment high volume purge:	
Number of purges per year (in addition to two shutdown purges)	0
Charcoal filter efficiency (%)	90
HEPA filter efficiency (%)	99
Containment normal continuous purge rate (ft ³ /min) (based on 20 hrs/week at 4000 ft ³ /min)	500
Charcoal filter efficiency (%)	90
HEPA filter efficiency (%)	99
Fraction of iodine released from blowdown tank vent	N/A
Fraction of iodine removed from main condenser air ejector release	0.0
Detergent Waste Decontamination Factor	0.0 ⁽²⁾

Notes:

1. A "0" is input to indicate that the blowdown is recycled to the condensate system after treatment in the blowdown system.
2. A "0.0" is input to indicate that the plant does not have an onsite laundry.

**Table 11.2-7 (Sheet 1 of 2)
Releases to Discharge Canal (Ci/Yr) Calculated by GALE Code**

Nuclide	Shim Bleed	Misc. Wastes	Turbine Building	Combined Releases	Total Releases ⁽¹⁾
Corrosion and Activation Products					
Na-24	0.00053	0.0 ⁽²⁾	0.00008	0.00061	0.00163
Cr-51	0.00068	0.0	0.0	0.00070	0.00185
Mn-54	0.00048	0.0	0.0	0.00049	0.00130
Fe-55	0.00037	0.0	0.0	0.00037	0.00100
Fe-59	0.00008	0.0	0.0	0.00008	0.00020
Co-58	0.00125	0.0	0.00001	0.00126	0.00336
Co-60	0.00016	0.0	0.0	0.00017	0.00044
Zn-65	0.00015	0.0	0.0	0.00015	0.00041
W-187	0.00004	0.0	0.0	0.00005	0.00013
Np-239	0.00008	0.0	0.0	0.00009	0.00024
Fission Products					
Br-84	0.00001	0.0	0.0	0.00001	0.00002
Rb-88	0.00010	0.0	0.0	0.00010	0.00027
Sr-89	0.00004	0.0	0.0	0.00004	0.00010
Sr-90	0.0	0.0	0.0	0.0	0.00001
Sr-91	0.00001	0.0	0.0	0.00001	0.00002
Y-91m	0.0	0.0	0.0	0.00001	0.00001
Y-93	0.00003	0.0	0.0	0.00004	0.00009
Zr-95	0.00010	0.0	0.0	0.00011	0.00023
Nb-95	0.00009	0.0	0.0	0.00009	0.00021
Mo-99	0.00028	0.0	0.00001	0.0003	0.00057
Tc-99m	0.00027	0.0	0.00001	0.00028	0.00055
Ru-103	0.00183	0.00001	0.00002	0.00185	0.00493
Rh-103m	0.00183	0.00001	0.00002	0.00185	0.00493
Ru-106	0.02729	0.00011	0.00021	0.02761	0.07352
Rh-106	0.02729	0.00011	0.00021	0.02761	0.07352
Ag-110m	0.00039	0.0	0.0	0.00039	0.00105
Ag-110	0.00005	0.0	0.0	0.00005	0.00014
Te-129m	0.00004	0.0	0.0	0.00005	0.00012
Te-129	0.00006	0.0	0.0	0.00006	0.00015

**Table 11.2-7 (Sheet 2 of 2)
Releases to Discharge Canal (Ci/Yr) Calculated by GALE Code**

Nuclide	Shim Bleed	Misc. Wastes	Turbine Building	Combined Releases	Total Releases ⁽¹⁾
Te-131m	0.00003	0.0	0.0	0.00003	0.00009
Te-131	0.00001	0.0	0.0	0.00001	0.00003
I-131	0.00512	0.00004	0.00015	0.00531	0.01413
Te-132	0.00009	0.0	0.0	0.00009	0.00024
I-132	0.00054	0.00001	0.00007	0.00062	0.00164
I-133	0.00211	0.00003	0.00038	0.00252	0.00670
I-134	0.00030	0.0	0.0	0.00031	0.00081
Cs-134	0.00370	0.00001	0.00002	0.00373	0.00993
I-135	0.00144	0.00002	0.00041	0.00187	0.00497
Cs-136	0.00023	0.0	0.0	0.00024	0.00063
Cs-137	0.00496	0.00001	0.00003	0.00500	0.01332
Ba-137m	0.00464	0.00001	0.00002	0.00468	0.01245
Ba-140	0.00203	0.00001	0.00003	0.00207	0.00552
La-140	0.00272	0.00002	0.00005	0.00279	0.00743
Ce-141	0.00003	0.0	0.0	0.00004	0.00009
Ce-143	0.00006	0.0	0.00001	0.00007	0.00019
Pr-143	0.00005	0.0	0.0	0.00005	0.00013
Ce-144	0.00117	0.0	0.00001	0.00119	0.00316
Pr-144	0.00117	0.0	0.00001	0.00119	0.00316
All others	0.00001	0.0	0.0	0.00001	0.00002
Total (except tritium)	0.09398	0.00043	0.00182	0.09623	0.25623
Tritium release = 1010 curies per year					

Notes:

1. The release totals include an adjustment of 0.16 Ci/yr added by PWR-GALE code to account for anticipated operational occurrences such as operator errors that result in unplanned releases.
2. An entry of 0.0 indicates that the value is less than 10⁻⁵ Ci/yr.

Table 11.2-8 (Sheet 1 of 2)
Comparison of Annual Average Liquid Release Concentrations with 10 CFR 20 for
Expected Releases Effluent Concentration Limits

Nuclide	Discharge Concentration ($\mu\text{Ci/ml}$)⁽¹⁾	Effluent Concentration Limit ($\mu\text{Ci/ml}$)⁽²⁾	Fraction of Concentration Limit
Na-24	1.7E-10	5.0E-05	3.4E-06
Cr-51	1.9E-10	5.0E-04	3.9E-07
Mn-54	1.4E-10	3.0E-05	4.5E-06
Fe-55	1.0E-10	1.0E-04	1.0E-06
Fe-59	2.1E-11	1.0E-05	2.1E-06
Co-58	3.5E-10	2.0E-05	1.8E-05
Co-60	4.6E-11	3.0E-06	1.5E-05
Zn-65	4.3E-11	5.0E-06	8.6E-06
W-187	1.4E-11	3.0E-05	4.5E-07
Np-239	2.5E-11	2.0E-05	1.3E-06
Br-84	2.1E-12	4.0E-04	5.2E-09
Rb-88	2.8E-11	4.0E-04	7.1E-08
Sr-89	1.0E-11	8.0E-06	1.3E-06
Sr-91	2.1E-12	2.0E-05	1.0E-07
Y-91m	1.0E-12	2.0E-03	5.2E-10
Y-93	1.2E-11	2.0E-05	5.8E-07
Zr-95	2.9E-11	2.0E-05	1.5E-06
Nb-95	2.6E-11	3.0E-05	8.7E-07
Mo-99	8.4E-11	2.0E-05	4.2E-06
Tc-99m	8.0E-11	1.0E-03	8.0E-08
Ru-103	5.2E-10	3.0E-05	1.7E-05
Rh-103m	5.2E-10	6.0E-03	8.6E-08
Ru-106	7.7E-09	3.0E-06	2.6E-03

Table 11.2-8 (Sheet 2 of 2)
Comparison of Annual Average Liquid Release Concentrations with 10 CFR 20 for
Expected Releases Effluent Concentration Limits

Nuclide	Discharge Concentration ($\mu\text{Ci/ml}$) ⁽¹⁾	Effluent Concentration Limit ($\mu\text{Ci/ml}$) ⁽²⁾	Fraction of Concentration Limit
Ag-110m	1.1E-10	6.0E-06	1.8E-05
Te-129m	1.3E-11	7.0E-06	1.8E-06
Te-129	1.6E-11	4.0E-04	3.9E-08
Te-131m	9.4E-12	8.0E-06	1.2E-06
Te-131	3.1E-12	8.0E-05	3.9E-08
I-131	1.5E-09	1.0E-06	1.5E-03
Te-132	2.5E-11	9.0E-06	2.8E-06
I-132	1.7E-10	1.0E-04	1.7E-06
I-133	7.0E-10	7.0E-06	1.0E-04
I-134	8.5E-11	4.0E-04	2.1E-07
Cs-134	1.0E-09	9.0E-07	1.2E-03
I-135	5.2E-10	3.0E-05	1.7E-05
Cs-136	6.6E-11	6.0E-06	1.1E-05
Cs-137	1.4E-09	1.0E-06	1.4E-03
Ba-140	5.8E-10	8.0E-06	7.2E-05
La-140	7.8E-10	9.0E-06	8.6E-05
Ce-141	9.4E-12	3.0E-05	3.1E-07
Ce-143	2.0E-11	2.0E-05	9.9E-07
PR-143	1.4E-11	2.5E-05	5.4E-07
Ce-144	3.3E-10	3.0E-06	1.1E-04
Pr-144	3.3E-10	6.0E-04	5.5E-07
H-3	1.1E-04	1.0E-03	1.1E-01
			Total = 0.11

Notes:

1. Annual average discharge concentration based on release of average daily discharge for 292 days per year with 6000 gpm dilution flow.
2. Effluent concentration limits are from [Reference 1](#).

Table 11.2-9 (Sheet 1 of 2)
Comparison of Annual Average Liquid Release Concentrations with 10 CFR 20 Effluent Concentration Limits for Releases with Maximum Defined Fuel Defects

Nuclide	Discharge Concentration ($\mu\text{Ci/ml}$)⁽¹⁾	Effluent Concentration Limit ($\mu\text{Ci/ml}$)⁽²⁾	Fraction of Concentration Limit
Na-24	1.7E-10	5.0E-05	3.4E-06
Cr-51	1.6E-10	5.0E-04	3.2E-07
Mn-54	1.4E-10	3.0E-05	4.5E-06
Fe-55	1.0E-10	1.0E-04	1.0E-06
Fe-59	2.1E-11	1.0E-05	2.1E-06
Co-58	3.5E-10	2.0E-05	1.8E-05
Co-60	4.6E-11	3.0E-06	1.5E-05
Zn-65	4.3E-11	5.0E-06	8.6E-06
W-187	1.4E-11	3.0E-05	4.5E-07
Np-239	2.5E-11	2.0E-05	1.3E-06
Br-84	4.6E-12	4.0E-04	1.1E-08
Rb-88	2.9E-10	4.0E-04	7.1E-07
Sr-89	1.8E-10	8.0E-06	2.3E-05
Sr-91	9.1E-12	2.0E-05	4.5E-07
Y-91m	7.0E-12	2.0E-03	3.5E-09
Y-93	1.2E-11	2.0E-05	5.8E-07
Zr-95	4.3E-11	2.0E-05	2.2E-06
Nb-95	4.6E-11	3.0E-05	1.5E-06
Mo-99	5.4E-09	2.0E-05	2.7E-04
Tc-99m	4.9E-09	1.0E-03	4.9E-06
Ru-103	3.4E-10	3.0E-05	1.1E-05
Rh-103m	3.4E-10	6.0E-03	5.7E-08
Ru-106	1.6E-08	3.0E-06	5.5E-03

Table 11.2-9 (Sheet 2 of 2)
Comparison of Annual Average Liquid Release Concentrations with 10 CFR 20 Effluent Concentration Limits for Releases with Maximum Defined Fuel Defects

Nuclide	Discharge Concentration ($\mu\text{Ci/ml}$) ⁽¹⁾	Effluent Concentration Limit ($\mu\text{Ci/ml}$) ⁽²⁾	Fraction of Concentration Limit
Ag-110m	1.4E-10	6.0E-06	2.3E-05
Te-129m	3.9E-10	7.0E-06	5.6E-05
Te-129	1.6E-11	4.0E-04	3.9E-08
Te-131m	7.4E-11	8.0E-06	9.3E-06
Te-131	4.0E-12	8.0E-05	5.0E-08
I-131	1.2E-08	1.0E-06	1.2E-02
Te-132	2.3E-09	9.0E-06	2.5E-04
I-132	3.6E-10	1.0E-04	3.6E-06
I-133	3.3E-09	7.0E-06	4.6E-04
I-134	8.5E-11	4.0E-04	2.1E-07
Cs-134	2.0E-07	9.0E-07	2.3E-01
I-135	9.1E-10	3.0E-05	3.0E-05
Cs-136	1.5E-07	6.0E-06	2.6E-02
Cs-137	1.5E-07	1.0E-06	1.5E-01
Ba-140	5.8E-10	8.0E-06	7.2E-05
La-140	7.8E-10	9.0E-06	8.6E-05
Ce-141	2.9E-11	3.0E-05	9.5E-07
Ce-143	2.0E-11	2.0E-05	9.9E-07
PR-143	1.4E-11	2.5E-05	5.4E-07
Ce-144	3.3E-10	3.0E-06	1.1E-04
Pr-144	3.3E-10	6.0E-04	5.5E-07
H-3	1.1E-04	1.0E-03	1.1E-01
			Total = 5.3E-01

Notes:

1. Annual average discharge concentration based on release of average daily discharge for 292 days per year with 6000 gpm dilution flow.
2. Effluent concentrations limits are from [Reference 1](#).

**Table 11.2-201
Liquid Pathway Parameters**

Parameter	Value
Release source terms	Table 11.2-203
Effluent discharge rate	9,229 ft ³ /sec ^a
Dilution factor for discharge	1 ^a
Transit time to receptor	0.1 hr for MEI, 16 hr average for population ^b
Impoundment reconcentration model	None ^c
Population within 50 miles	6.74E+05 ^d
Population sport fishing harvest	3.5E+04 kg/yr ^e
Population shoreline usage	9.6E+05 hr/yr ^e
Population swimming	1.6E+05 hr/yr ^e
Population boating	1.1E+06 hr/yr ^e

^a Liquid discharge assumed fully mixed with annual average flow rate of Savannah River at Vogtle.

^b 16 hr is the average transit time to a point halfway along 50-mile stretch of Savannah River.

^c Completely mixed model used for Savannah River.

^d See [Subsection 2.1.3.2](#).

^e Savannah River Site Environmental Report for 2005 ([Reference 208](#)).

**Table 11.2-202
Liquid Pathway Consumption Factors for Maximally Exposed Individual**

Consumption Factor	Annual Rate			
	Adult	Teen	Child	Infant
Fish consumption (kg/yr)	21	16	6.9	0
Drinking water consumption (l/yr)	730	510	510	330
Shoreline usage (hr/yr)	12	67	14	0

Note: These are obtained from Regulatory Guide 1.109.

**Table 11.2-203 (Sheet 1 of 3)
Release of Activities in Liquid Effluent**

Isotope	Release (Ci/yr)			Concentration (µCi/ml)		Fraction of ECL
	Units 3 & 4	Units 1 & 2	Total	Site	ECL	
H-3	2.0E+03	1.9E+03	4.0E+03	4.8E-07	1.0E-03	4.8E-04
Be-7	-	8.3E-06	8.3E-06	1.0E-15	6.0E-04	1.7E-12
Na-24	3.3E-03	2.7E-05	3.3E-03	4.0E-13	5.0E-05	8.0E-09
Cr-51	3.7E-03	2.2E-03	5.9E-03	7.1E-13	5.0E-04	1.4E-09
Mn-54	2.6E-03	3.7E-03	6.3E-03	7.6E-13	3.0E-05	2.5E-08
Fe-55	2.0E-03	7.7E-02	7.9E-02	9.6E-12	1.0E-04	9.6E-08
Fe-59	4.0E-04	1.9E-04	5.9E-04	7.1E-14	1.0E-05	7.1E-09
Co-57	-	1.1E-04	1.1E-04	1.3E-14	6.0E-05	2.2E-10
Co-58	6.7E-03	2.5E-02	3.2E-02	3.9E-12	2.0E-05	1.9E-07
Co-60	8.8E-04	5.7E-02	5.7E-02	7.0E-12	3.0E-06	2.3E-06
Zn-65	8.2E-04	5.5E-06	8.3E-04	1.0E-13	5.0E-06	2.0E-08
Br-84	4.0E-05	-	4.0E-05	4.9E-15	4.0E-04	1.2E-11
Rb-86	-	9.3E-06	9.3E-06	1.1E-15	7.0E-06	1.6E-10
Rb-88	5.4E-04	-	5.4E-04	6.6E-14	4.0E-04	1.6E-10
Sr-89	2.0E-04	2.7E-04	4.7E-04	5.7E-14	8.0E-06	7.2E-09
Sr-90	2.0E-05	1.5E-04	1.7E-04	2.0E-14	5.0E-07	4.0E-08
Sr-91	4.0E-05	-	4.0E-05	4.9E-15	2.0E-05	2.4E-10
Sr-92	-	2.4E-05	2.4E-05	2.9E-15	4.0E-05	7.2E-11
Y-91m	2.0E-05	-	2.0E-05	2.4E-15	2.0E-03	1.2E-12
Y-91	-	2.3E-04	2.3E-04	2.8E-14	8.0E-06	3.5E-09
Y-92	-	9.3E-06	9.3E-06	1.1E-15	4.0E-05	2.8E-11
Y-93	1.8E-04	4.0E-05	2.2E-04	2.7E-14	2.0E-05	1.3E-09
Zr-95	4.6E-04	6.3E-04	1.1E-03	1.3E-13	2.0E-05	6.6E-09
Nb-95	4.2E-04	1.3E-03	1.7E-03	2.0E-13	3.0E-05	6.8E-09
Nb-97	-	1.6E-04	1.6E-04	1.9E-14	3.0E-04	6.4E-11
Mo-99	1.1E-03	-	1.1E-03	1.4E-13	2.0E-05	6.9E-09
Tc-99m	1.1E-03	-	1.1E-03	1.3E-13	1.0E-03	1.3E-10
Ru-103	9.9E-03	-	9.9E-03	1.2E-12	3.0E-05	4.0E-08

**Table 11.2-203 (Sheet 2 of 3)
Release of Activities in Liquid Effluent**

Isotope	Release (Ci/yr)			Concentration (µCi/ml)		Fraction of ECL
	Units 3 & 4	Units 1 & 2	Total	Site	ECL	
Ru-106	1.5E-01	-	1.5E-01	1.8E-11	3.0E-06	5.9E-06
Rh-103m	9.9E-03	-	9.9E-03	1.2E-12	6.0E-03	2.0E-10
Rh-106	1.5E-01	-	1.5E-01	1.8E-11	-	-
Ag-110m	2.1E-03	5.6E-05	2.2E-03	2.6E-13	6.0E-06	4.4E-08
Ag-110	2.8E-04	-	2.8E-04	3.4E-14	-	-
Sn-113	-	3.6E-06	3.6E-06	4.4E-16	3.0E-05	1.5E-11
Sb-122	-	4.7E-06	4.7E-06	5.6E-16	1.0E-05	5.6E-11
Sb-124	-	1.7E-04	1.7E-04	2.0E-14	7.0E-06	2.9E-09
Sb-125	-	1.9E-02	1.9E-02	2.4E-12	3.0E-05	7.9E-08
Te-125m	-	4.9E-02	4.9E-02	5.9E-12	2.0E-05	3.0E-07
Te-129m	2.4E-04	-	2.4E-04	2.9E-14	7.0E-06	4.2E-09
Te-129	3.0E-04	-	3.0E-04	3.6E-14	4.0E-04	9.1E-11
Te-131m	1.8E-04	-	1.8E-04	2.2E-14	8.0E-06	2.7E-09
Te-131	6.0E-05	-	6.0E-05	7.3E-15	8.0E-05	9.1E-11
Te-132	4.8E-04	5.1E-05	5.3E-04	6.4E-14	9.0E-06	7.2E-09
I-131	2.8E-02	5.5E-05	2.8E-02	3.4E-12	1.0E-06	3.4E-06
I-132	3.3E-03	4.7E-05	3.3E-03	4.0E-13	1.0E-04	4.0E-09
I-133	1.3E-02	3.6E-05	1.3E-02	1.6E-12	7.0E-06	2.3E-07
I-134	1.6E-03	-	1.6E-03	2.0E-13	4.0E-04	4.9E-10
I-135	9.9E-03	-	9.9E-03	1.2E-12	3.0E-05	4.0E-08
Cs-134	2.0E-02	1.5E-03	2.1E-02	2.6E-12	9.0E-07	2.9E-06
Cs-136	1.3E-03	-	1.3E-03	1.5E-13	6.0E-06	2.5E-08
Cs-137	2.7E-02	2.6E-03	2.9E-02	3.6E-12	1.0E-06	3.6E-06
Ba-137m	2.5E-02	-	2.5E-02	3.0E-12	-	-
Ba-140	1.1E-02	-	1.1E-02	1.3E-12	8.0E-06	1.7E-07
La-140	1.5E-02	3.5E-06	1.5E-02	1.8E-12	9.0E-06	2.0E-07
Ce-141	1.8E-04	1.7E-06	1.8E-04	2.2E-14	3.0E-05	7.4E-10
Ce-143	3.8E-04	-	3.8E-04	4.6E-14	2.0E-05	2.3E-09
Ce-144	6.3E-03	-	6.3E-03	7.7E-13	3.0E-06	2.6E-07

**Table 11.2-203 (Sheet 3 of 3)
Release of Activities in Liquid Effluent**

Isotope	Release (Ci/yr)			Concentration (µCi/ml)		Fraction of ECL
	Units 3 & 4	Units 1 & 2	Total	Site	ECL	
Pr-143	2.6E-04	-	2.6E-04	3.2E-14	2.0E-05	1.6E-09
Pr-144	6.3E-03	-	6.3E-03	7.7E-13	6.0E-04	1.3E-09
Hf-181	-	3.9E-07	3.9E-07	4.7E-17	2.0E-05	2.4E-12
W-187	2.6E-04	-	2.6E-04	3.2E-14	3.0E-05	1.1E-09
Np-239	4.8E-04	-	4.8E-04	5.8E-14	2.0E-05	2.9E-09
Total	2.0E+03	1.9E+03	4.0E+03	4.8E-07	-	5.0E-04

Note: The releases for Units 3 and 4 are based on the AP1000 DCD (Reference 207) and are for two units. The releases for Units 1 and 2 are based on annual effluent release reports (References 204, 205, 206) and are for two units. The effluent concentration limits (ECLs) are from 10 CFR 20, Appendix B, Table 2, Column 2.

**Table 11.2-204
Liquid Pathway Doses for Maximally Exposed Individuals**

	Dose per Unit (mrem/yr)							
	Skin	Bone	Liver	Total Body	Thyroid	Kidney	Lung	GI-LLI
Adult	1.3E-05	8.8E-03	2.1E-02	1.7E-02	9.0E-03	1.1E-02	7.2E-03	7.9E-03
Teen	7.2E-05	9.3E-03	2.0E-02	1.0E-02	7.0E-03	9.2E-03	5.9E-03	5.7E-03
Child	1.5E-05	1.2E-02	2.1E-02	9.9E-03	1.3E-02	1.2E-02	8.9E-03	8.6E-03
Infant	0.0E+00	5.8E-04	7.8E-03	7.2E-03	1.5E-02	7.4E-03	7.2E-03	7.7E-03
Maximum	7.2E-05	1.2E-02	2.1E-02	1.7E-02	1.5E-02	1.2E-02	8.9E-03	8.6E-03
	Teen	Child	Child	Adult	Infant	Child	Child	Child

Note: GI-LLI is gastrointestinal-lining of lower intestine.

**Table 11.2-205
Comparison of Maximally Exposed Individual Doses with 10 CFR 50, Appendix I Criteria**

	Location	Dose per Unit (mrem/yr)	
		Estimated	Limit
Total Body	Savannah River	0.017	3
Maximum Organ - Liver	Savannah River	0.021	10

**Table 11.2-206
Comparison of Maximally Exposed Individual Doses with 40 CFR 190 Criteria**

	Dose (mrem/yr)					
	Units 3 and 4			Units 1 and 2	Site Total	Regulatory Limit
	Liquid	Gaseous	Total			
Total Body	0.020	2.2	2.3	0.092	2.4	25
Thyroid	0.027	12	12	0.069	12	75
Other Organ - Bone	0.023	8.8	8.8	0.054	8.9	25

Note: Doses for Units 3 and 4 are for a child, the age group receiving the maximum total dose. Doses for Units 1 and 2 are the maximum reported in the annual effluent release reports for 2001, 2002, and 2003 (References 204, 205, 206).

**Table 11.2-207
Collective Total Body Doses Within 50 Miles**

	Dose (person-rem/yr)
Units 3 & 4	0.037
Units 1 & 2	0.0079
Total	0.045

Note: Doses for Units 1 and 2 are based on the maximum activity releases in the annual effluent release reports for 2001, 2002, and 2003 (References 204, 205, 206).

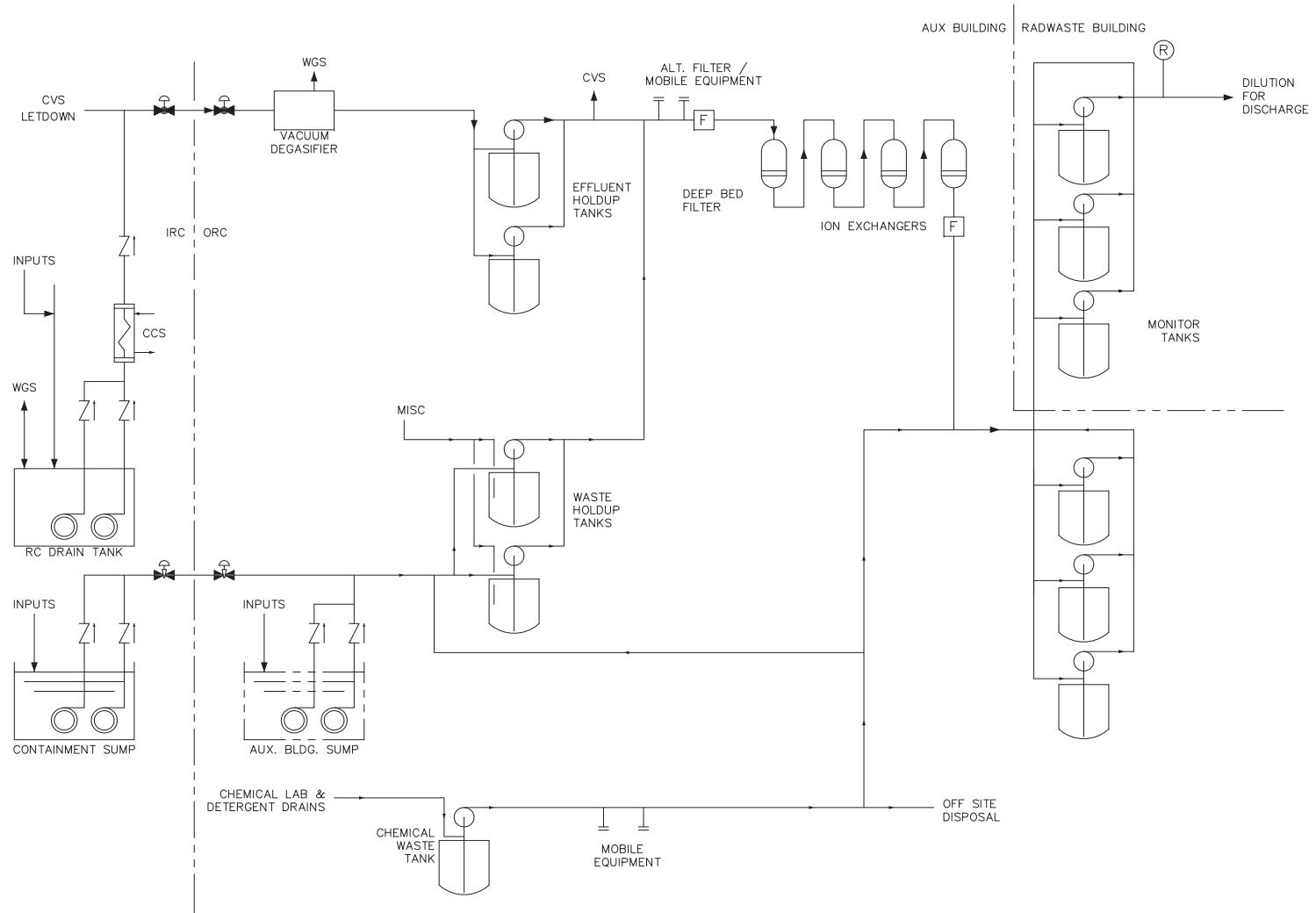

Figure 11.2-1
Liquid Radwaste System
Simplified Piping and Instrumentation Diagram
(REF) WLS

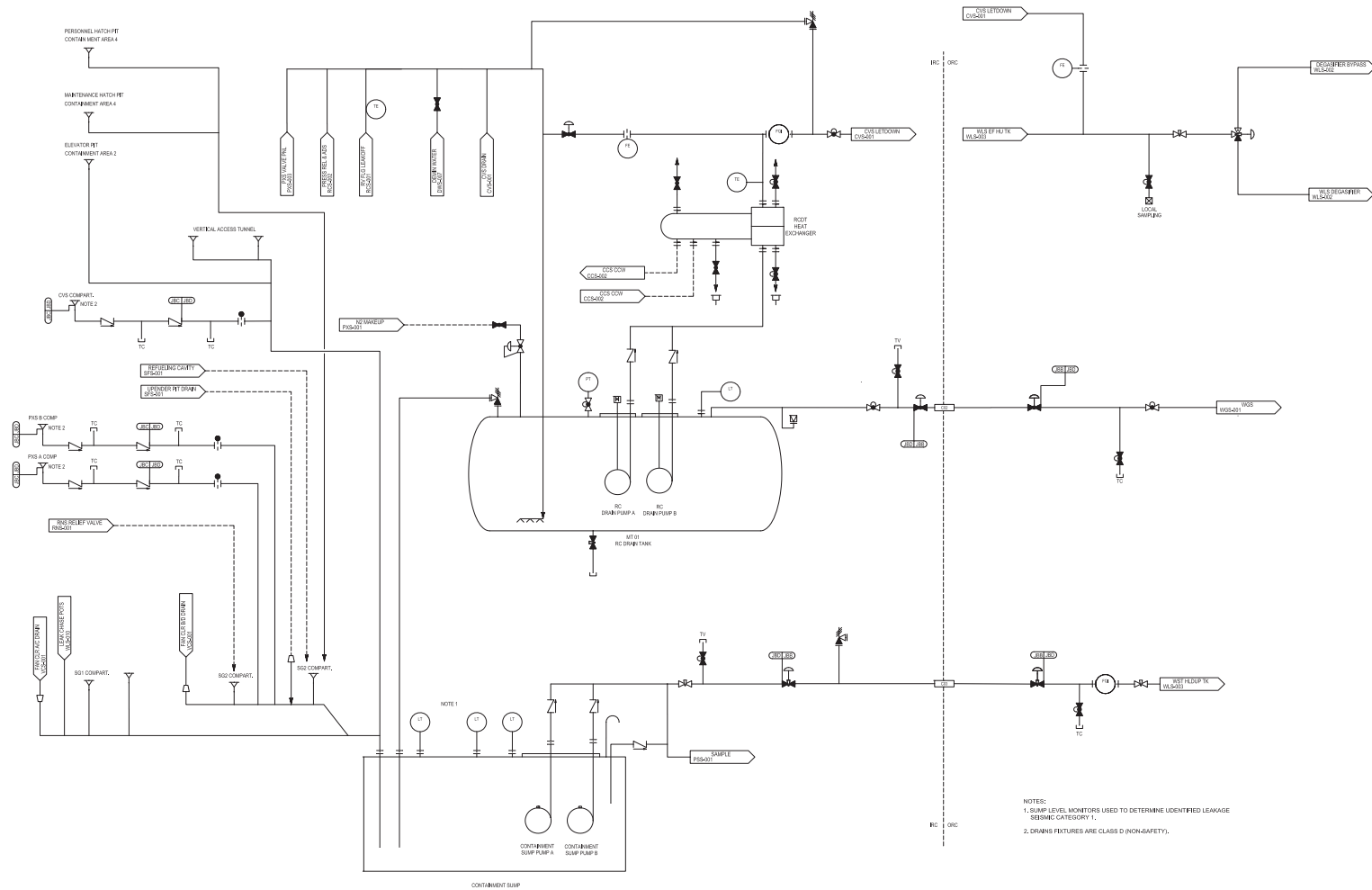

Figure represents system functional arrangement. Details internal to the system may differ as a result of implementation factors such as vendor-specific component requirements.

Figure 11.2-2 (Sheet 1 of 8)
 Liquid Radwaste System
 Piping and Instrumentation Diagram
 (REF) WLS 001

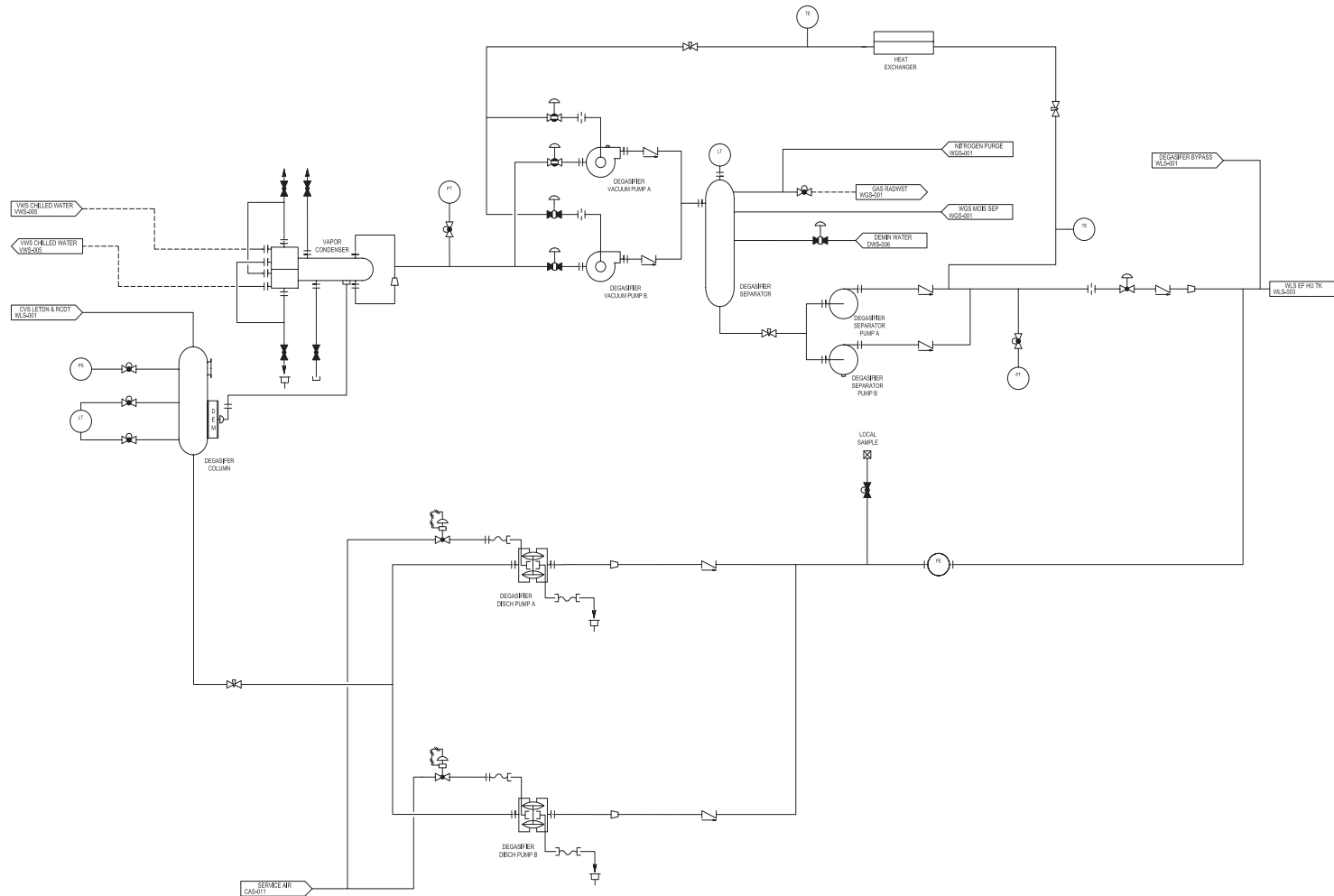

Figure represents system functional arrangement. Details internal to the system may differ as a result of implementation factors such as vendor-specific component requirements.

Inside Auxiliary Building
 Figure 11.2-2 (Sheet 2 of 8)
 Liquid Radwaste System
 Piping and Instrumentation Diagram
 (REF) WLS 002

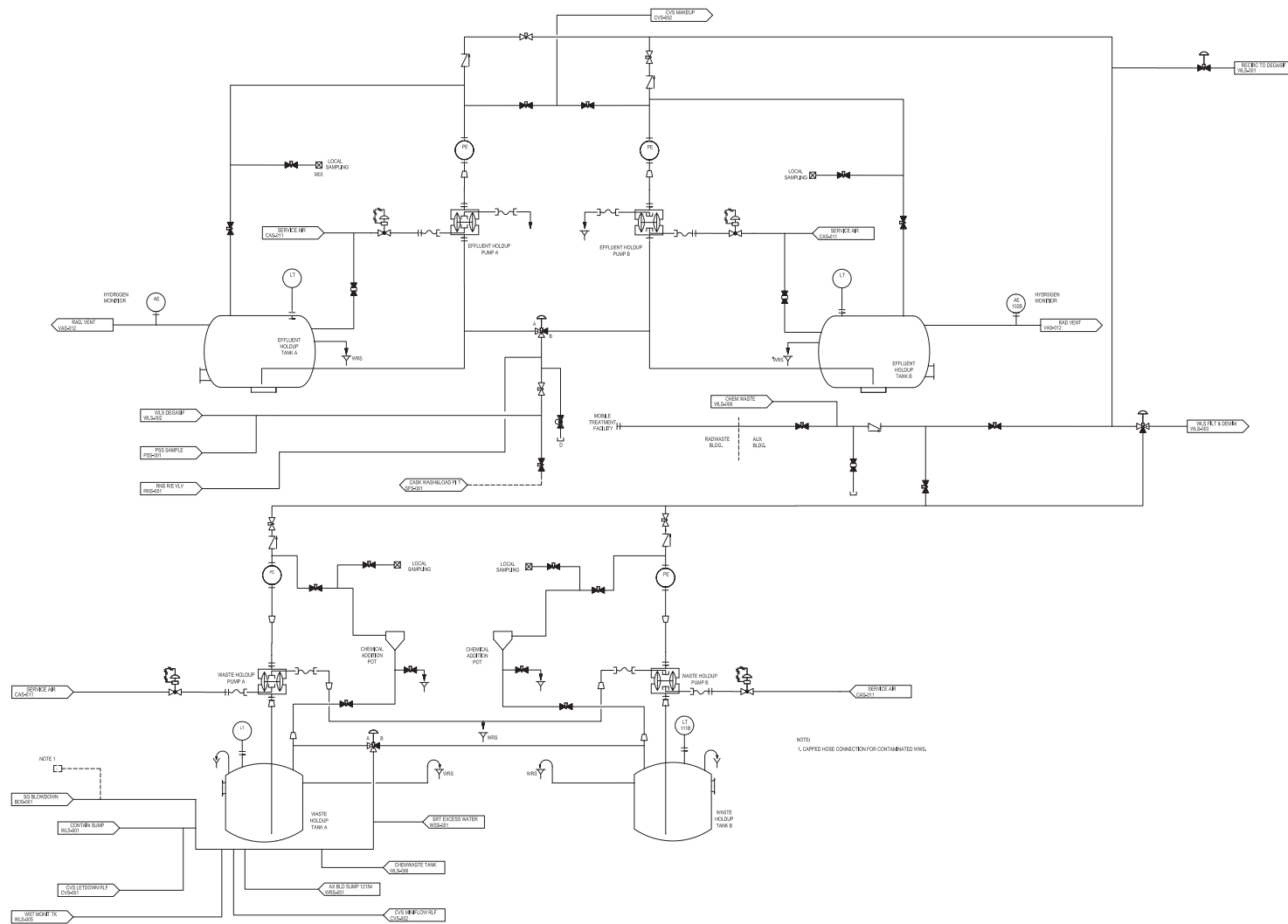

Figure represents system functional arrangement. Details internal to the system may differ as a result of implementation factors such as vendor-specific component requirements.

Figure 11.2-2 (Sheet 3 of 8)
Liquid Radwaste System
Piping and Instrumentation Diagram
(REF WLS 003)

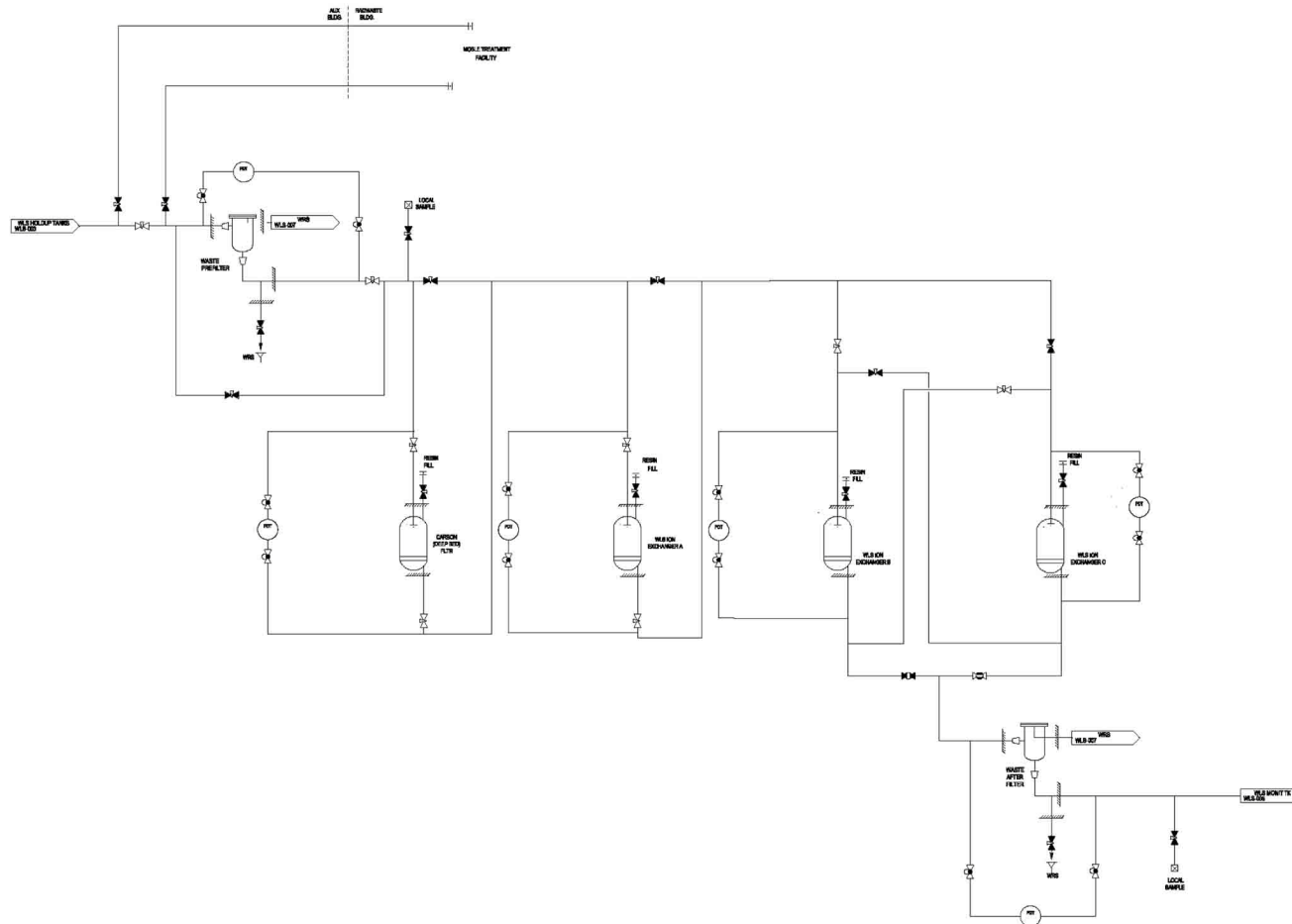

Figure represents system functional arrangement. Details internal to the system may differ as a result of implementation factors such as vendor-specific component requirements.

Figure 11.2-2 (Sheet 4 of 8)
Liquid Radwaste System
Piping and Instrumentation Diagram
(REF) WLS 004

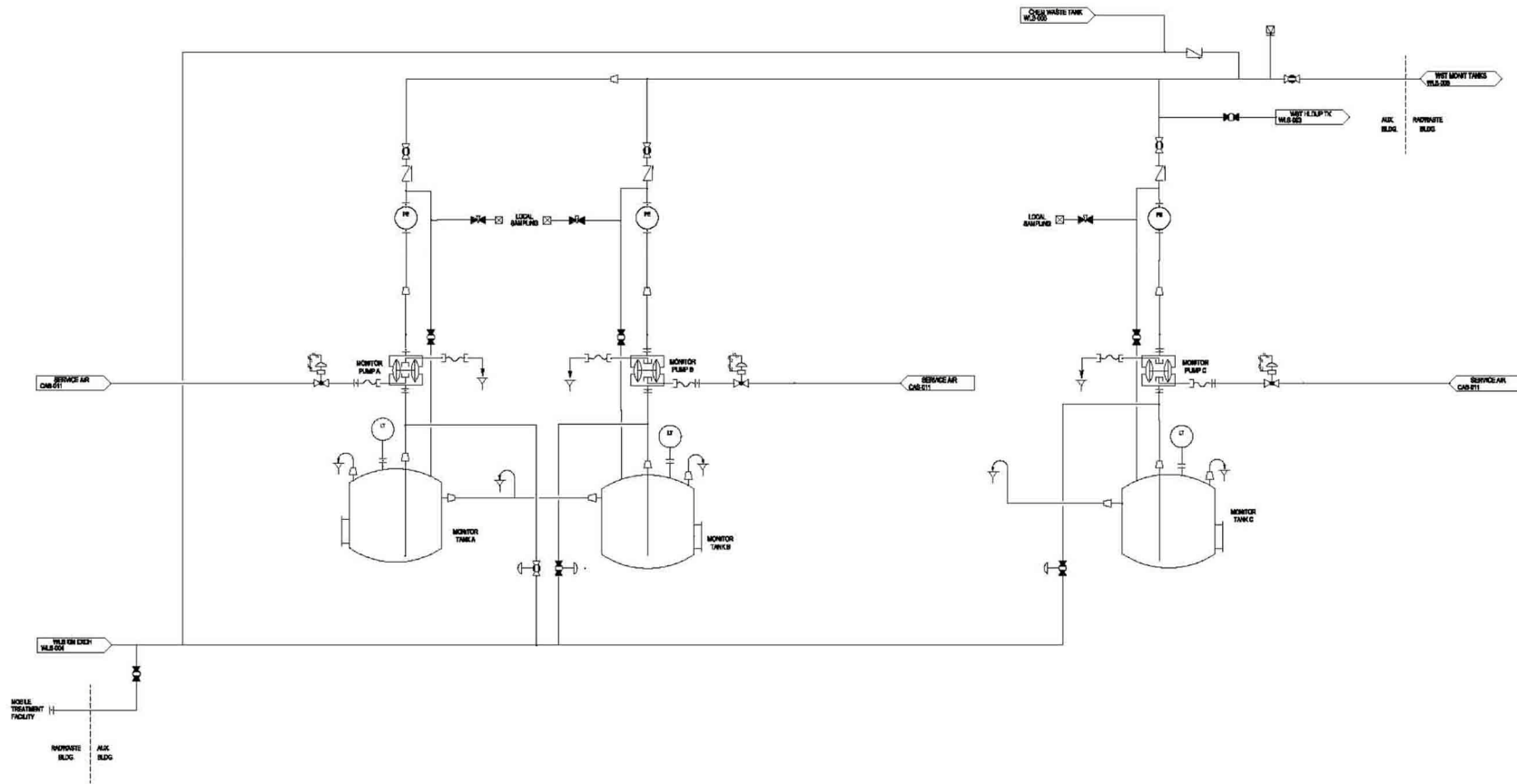

Figure represents system functional arrangement. Details internal to the system may differ as a result of implementation factors such as vendor-specific component requirements.

Figure 11.2-2 (Sheet 5 of 8)
Liquid Radwaste System
Piping and Instrumentation Diagram
(REF) WLS 005

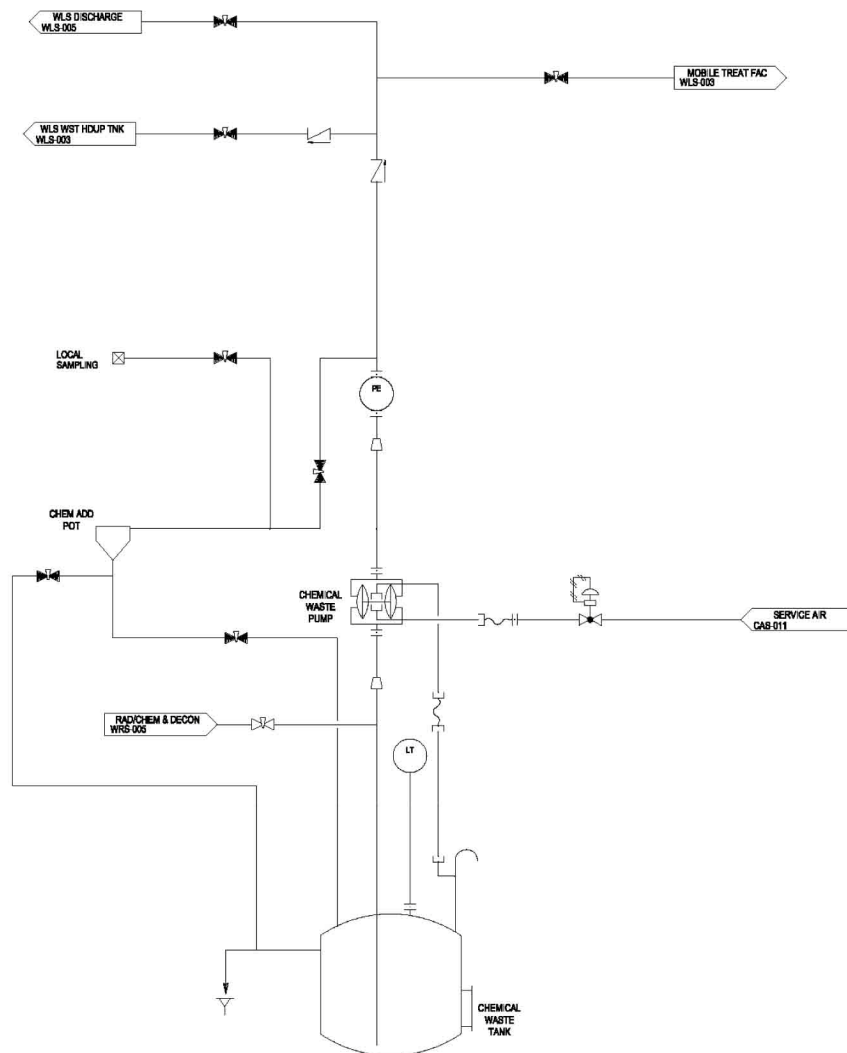

Figure represents system functional arrangement. Details internal to the system may differ as a result of implementation factors such as vendor-specific component requirements.

Inside Auxiliary Building
 Figure 11.2-2 (Sheet 6 of 8)
 Liquid Radwaste System
 Piping and Instrumentation Diagram
 (REF) WLS 006

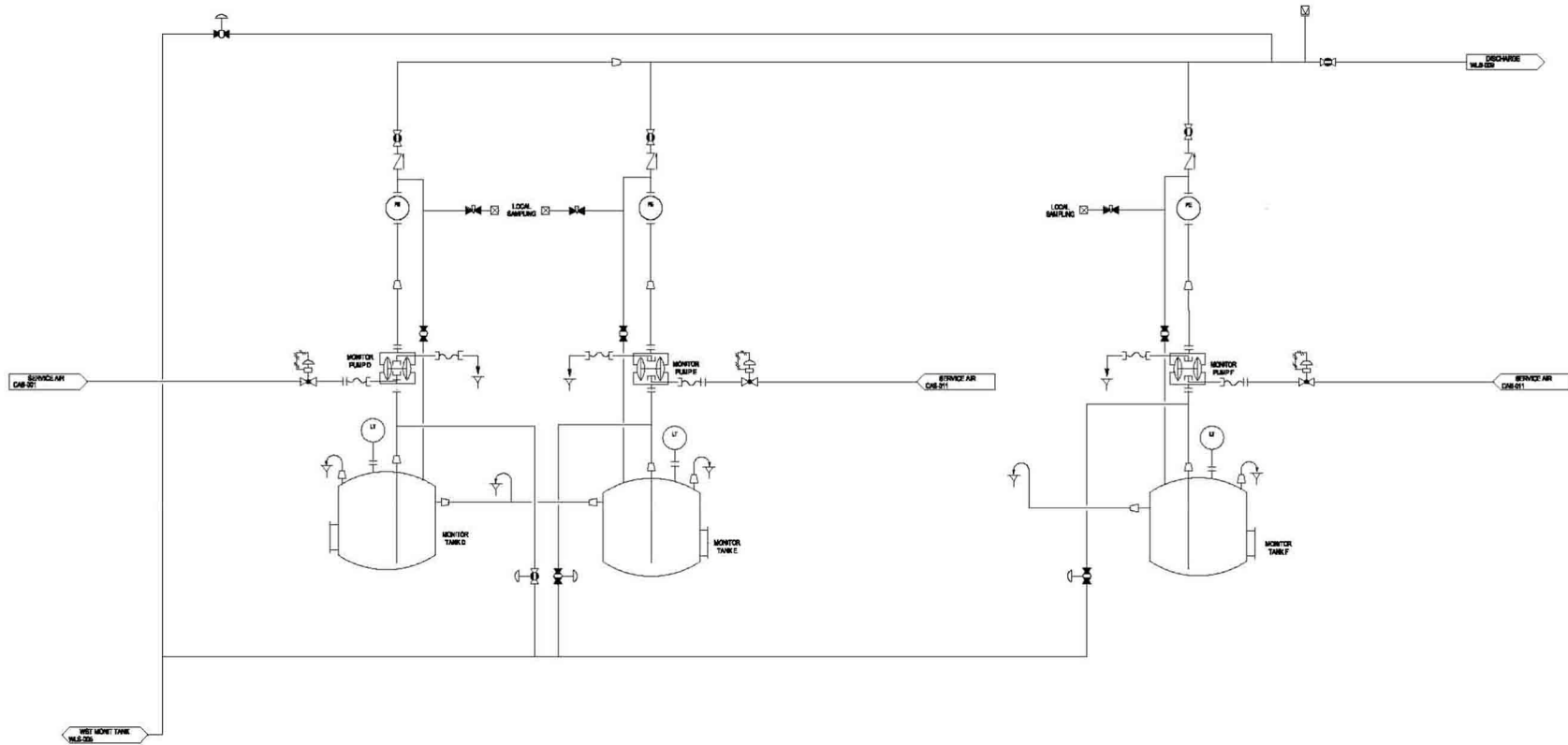

Figure represents system functional arrangement. Details internal to the system may differ as a result of implementation factors such as vendor-specific component requirements.

Inside Radwaste Building
 Figure 11.2-2 (Sheet 7 of 8)
 Liquid Radwaste System
 Piping and Instrumentation Diagram
 (REF) WLS 008

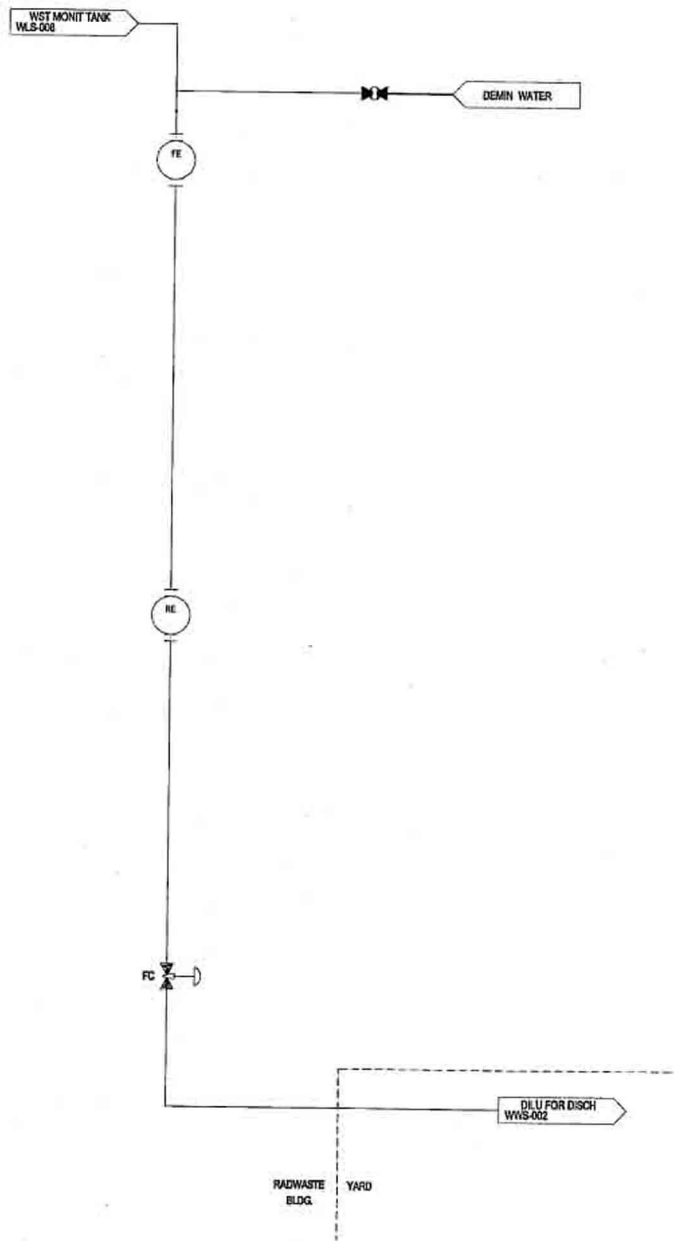

Figure represents system functional arrangement. Details internal to the system may differ as a result of implementation factors such as vendor-specific component requirements.

Inside Radwaste Building
 Figure 11.2-2 (Sheet 8 of 8)
 Liquid Radwaste System
 Piping and Instrumentation Diagram
 (REF) WLS 009

11.3 Gaseous Waste Management System

During reactor operation, radioactive isotopes of xenon, krypton, and iodine are created as fission products. A portion of these radionuclides is released to the reactor coolant because of a small number of fuel cladding defects. Leakage of reactor coolant thus results in a release to the containment atmosphere of the noble gases. Airborne releases can be limited both by restricting reactor coolant leakage and by limiting the concentrations of radioactive noble gases and iodine in the reactor coolant system.

Iodine is removed by ion exchange in the chemical and volume control system (CVS). Removal of the noble gases from the reactor coolant system (RCS) is not normally necessary because the gases will not build up to unacceptable levels when fuel defects are within normally anticipated ranges. If noble gas removal is required because of high reactor coolant system concentration, the chemical and volume control system can be operated in conjunction with the liquid radwaste system degasifier, to remove the gases. See [Subsection 9.3.6](#) for a description of these operations.

The AP1000 gaseous radwaste system (WGS) is designed to perform the following major functions:

- Collect gaseous wastes that are radioactive or hydrogen bearing
- Process and discharge the waste gas, keeping off-site releases of radioactivity within acceptable limits.

In addition to the gaseous radwaste system release pathway, release of radioactive material to the environment occurs through the various building ventilation systems. These systems are described in [Section 9.4](#) with a summary of system air flow rates and filter efficiencies provided in [Table 9.4-1](#). The estimated annual release reported in [Subsection 11.3.3](#) includes contributions from the major building ventilation pathways.

11.3.1 Design Basis

[Subsection 1.9.1](#) discusses the conformance of the gaseous radwaste system design with the criteria of Regulatory Guide 1.143.

11.3.1.1 Safety Design Basis

The gaseous radwaste system serves no safety-related functions and therefore has no nuclear safety design basis.

11.3.1.2 Power Generation Design Basis

11.3.1.2.1 Capacity

11.3.1.2.1.1 Gaseous Waste Collection

The gaseous radwaste system is designed to receive hydrogen bearing and radioactive gases generated during process operation. The radioactive gas flowing into the gaseous radwaste system enters as trace contamination in a stream of hydrogen and nitrogen.

The design basis period of operation is the last 45 days of a fuel cycle. During this time, reactor coolant system dilution and subsequent letdown from the chemical and volume control system into the liquid radwaste system is at a maximum. Gaseous radwaste system inputs are as follows:

- Letdown diversion for dilution, reactor coolant system with maximum hydrogen concentration. This input is 0.5 standard cubic feet per minute (scfm) on an intermittent basis carrying a very small volume of radiogas, yielding 550 scf total hydrogen.
- Letdown diversion for reactor coolant system degassing, assumed to remove gases from the reactor coolant system to a level of 1 cc/kg beginning with the reactor coolant system at the maximum hydrogen concentration of 40 cc/kg. At its maximum this input is 0.5 scfm hydrogen carrying a very small volume of radiogas yielding 245 scf total hydrogen.
- Reactor coolant drain tank liquid transfer to maintain proper reactor coolant drain tank level, assuming 0.25 gallons per minute liquid input from the reactor coolant system, intermittently yielding 0.5 scfm hydrogen and nitrogen carrying a very small volume of radiogas, yielding about 80 scf hydrogen and nitrogen total.
- Reactor coolant drain tank gas venting, conservatively estimated at 1 scf per day, yielding 45 scf total nitrogen and hydrogen.

11.3.1.2.1.2 Waste Gas Processing

The gaseous radwaste system is designed to reduce the controlled activity releases in support of the overall AP1000 release goals.

Given the various inputs to the gaseous radwaste system, with licensing basis assumptions for analysis and with normally operating gaseous radwaste system equipment available, the combined plant releases must be within the limits outlined in 10 CFR 20 and 10 CFR 50 Appendix I ([References 1](#) and [2](#), respectively).

11.3.1.2.2 Failure Tolerance

11.3.1.2.2.1 System Leakage

The gaseous radwaste system operates at low pressures, slightly above atmospheric pressure, thus limiting the potential for leakage. Manual valves are the type which eliminate the potential for stem leakage. The system is of welded construction to further limit leakage.

11.3.1.2.2.2 Water Incursion

A number of features prevent wetting the activated carbon delay beds. These features include controls and alarms in the liquid radwaste system to prevent high degasifier separator water level, the gas cooler, moisture separator, drain traps, and automatic isolation of the guard bed inlet on high moisture separator level in the gaseous radwaste system. Additional protection is provided by the activated carbon guard bed, which removes residual moisture as well as iodine from the gas stream.

If moisture enters the first activated carbon delay bed, the operator bypasses that bed and either dries it with a nitrogen purge or replaces the activated carbon.

11.3.1.2.3 Anticipated Operational Occurrences

11.3.1.2.3.1 Prevention of Hydrogen Ignition

Since the carrier gas for the radiogas inputs to the gaseous radwaste system includes hydrogen, the gaseous radwaste system is designed to prevent hydrogen ignition both within its own boundaries and in connected systems (the liquid radwaste system and the nuclear island radioactive ventilation system).

The gaseous radwaste system is operated at a slightly positive pressure to prevent air ingress. The room containing gaseous radwaste system components incorporates a hydrogen monitor to detect leakage out of the system before combustible levels are reached. In addition, continuous oxygen analysis, using independent, redundant monitors, is provided within the gaseous radwaste system. Upon high oxygen level in the system, an alarm alerts the operator. **At an oxygen concentration of 3 percent or less, the liquid radwaste system vacuum pumps automatically stop to isolate potentially oxygenated inputs to the gaseous radwaste system, and a valve automatically opens to initiate a nitrogen purge.** The discharge isolation valve of the gaseous radwaste system is continuously pressurized with nitrogen to prevent ingress of air into the system from the discharge path.

The gaseous radwaste system also eliminates sources of hydrogen ignition. **The system incorporates electrical grounding, and a nitrogen purge. In addition, the system design and control logic minimizes automatic actuation of valves when an oxygen concentration of greater than 3 percent exists in the system.** Discharge to the heating, ventilating and air-conditioning duct is downstream of the exhaust fans to provide additional protection against hydrogen ignition.

11.3.1.2.4 Controlled Release of Radioactivity

11.3.1.2.4.1 Expected Releases

The AP1000 design prevents the annual average concentration limits established by 10 CFR 20 (Appendix B, table 2, column 1) (**Reference 1**) for gaseous releases from being exceeded due to the releases resulting during plant operation. **Subsection 11.3.3** describes the calculated releases of radioactive materials from the gaseous radwaste system and other pathways during normal operation.

Subsection 11.3.3 also contains an evaluation which demonstrates that the doses to individuals, at or beyond the site boundary, resulting from the expected releases from the gaseous waste management systems are within numerical design objectives of Appendix I of 10 CFR 50 (**Reference 2**).

11.3.1.2.4.2 Monitoring Releases

Releases from the gaseous radwaste system are continuously monitored by a radiation detector in the discharge line. In addition, the system includes provisions for taking grab samples of the discharge flow stream for analysis. In this manner, the requirements of General Design Criterion 64 are met as described in **Section 3.1. Section 11.5** discusses radiation monitoring.

11.3.1.2.4.3 Operator Error or Equipment Malfunction

To prevent the release of radioactive gases resulting from equipment failure or operator error, a radiation monitor is located in the discharge line. This instrument provides an alarm signal at a high level setpoint to alert operators of rising radiation levels. The monitor is also interlocked with an isolation valve in the discharge line; the valve closes at a higher level setpoint.

Few operator actions are required during gaseous radwaste system operation since, once aligned for operation, the system operates automatically in response to the control signals from the instrumentation.

11.3.1.3 Compliance with 10 CFR 20.1406

In accordance with the requirements of 10 CFR 20.1406 (**Reference 4**), the gaseous radwaste system is designed to minimize, to the extent practicable, contamination of the facility and the

environment, facilitate decommissioning, and minimize, to the extent practicable, the generation of radioactive waste. This is done through appropriate selection of design technology for the system.

11.3.2 System Description

11.3.2.1 General Description

The AP1000 gaseous radwaste system, as shown on **Figure 11.3-1** is a once-through, ambient-temperature, activated carbon delay system. The system includes a gas cooler, a moisture separator, an activated carbon-filled guard bed, and two activated carbon-filled delay beds. Also included in the system are an oxygen analyzer subsystem and a gas sampling subsystem.

The radioactive fission gases entering the system are carried by hydrogen and nitrogen gas. The primary influent source is the liquid radwaste system degasifier. The degasifier extracts both hydrogen and fission gases from the chemical and volume control system letdown flow which is diverted to the liquid radwaste system or from the reactor coolant drain tank discharge.

Reactor coolant degassing is not required during power operation with fuel defects at or below the design basis level of 0.25 percent. However, the gaseous radwaste system periodically receives influent when chemical and volume control system letdown is processed through the liquid radwaste system degasifier during reactor coolant system dilution and volume control operations. Since the degasifier is a vacuum type and requires no purge gas, the maximum gas influent rate to the gaseous radwaste system from the degasifier equals the rate that hydrogen enters the degasifier (dissolved in liquid).

The other major source of input to the gaseous radwaste system is the reactor coolant drain tank. Hydrogen dissolved in the influent to the reactor coolant drain tank enters the gaseous radwaste system either via the tank vent or the liquid radwaste system degasifier discharge.

The tank vent is normally closed, but is periodically opened on high pressure to vent the gas that has come out of solution. The reactor coolant drain tank liquid is normally discharged to the liquid radwaste system via the degasifier, where the remaining hydrogen is removed.

The reactor coolant drain tank is purged with nitrogen gas to discharge nitrogen and fission gases to the gaseous radwaste system before operations requiring tank access. The reactor coolant drain tank is also purged with nitrogen gas to dilute and discharge oxygen after tank servicing or inspection operations which allow air to enter the tank.

Influents to the gaseous radwaste system first pass through the gas cooler where they are cooled to about 40°F by the chilled water system. Moisture formed due to gas cooling is removed in the moisture separator.

After leaving the moisture separator, the gas flows through a guard bed that protects the delay beds from abnormal moisture carryover or chemical contaminants. The gas then flows through two delay beds in series where the fission gases undergo dynamic adsorption by the activated carbon and are thereby delayed relative to the hydrogen or nitrogen carrier gas flow. Radioactive decay of the fission gases during the delay period significantly reduces the radioactivity of the gas flow leaving the system.

The effluent from the delay bed passes through a radiation monitor and discharges to the ventilation exhaust duct. The radiation monitor is interlocked to close the gaseous radwaste system discharge isolation valve on high radiation. The discharge isolation valve also closes on low ventilation system exhaust flow rate to prevent the accumulation of hydrogen in the aerated vent.

11.3.2.2 System Operation

11.3.2.2.1 Normal Operation

The gaseous radwaste system is used intermittently. Most of the time during normal operation of the AP1000, the gaseous radwaste system is inactive. When there is no waste gas inflow to the system, the discharge isolation valve closes, which maintains the gaseous radwaste system at a positive pressure, preventing the ingress of air during the periods of low waste gas flow.

When the gaseous radwaste system is in use, its operation is passive, using the pressure provided by the influent sources to drive the waste gas through the system.

The largest input to the gaseous radwaste system is from the liquid radwaste system degasifier, which processes the chemical and volume control system letdown flow when diverted to the liquid radwaste system and the liquid effluent from the liquid radwaste system reactor coolant drain tank.

The chemical and volume control system letdown flow is diverted to the liquid radwaste system during dilutions, borations, and reactor coolant system degassing in anticipation of shutdown. The design basis influent rate from the liquid radwaste system degasifier is the full diversion of the chemical and volume control system letdown flow, when the reactor coolant system is operating with maximum allowable hydrogen concentration. Since the liquid radwaste system degasifier is a vacuum type that operates without a purge gas, this input rate is very small, about 0.5 scfm.

The liquid radwaste system degasifier is also used to degas liquid pumped out of the reactor coolant drain tank. The amount of fluid pumped out, and therefore the gas sent to the gaseous radwaste system, is dependent upon the input into the reactor coolant drain tank. This is smaller than the input from the chemical and volume control system letdown line.

The final input to the gaseous radwaste system is from the reactor coolant drain tank vent. A nitrogen cover gas is maintained in the reactor coolant drain tank. This input consists of nitrogen, hydrogen, and radioactive gases. The tank operates at nearly constant level, with its vent line normally closed, so this input is minimal. Venting is required only after enough gas has evolved from the input fluid to increase the reactor coolant drain tank pressure.

The influent first passes through a gas cooler. Chilled water flows through the gas cooler at a fixed rate to cool the waste gas to about 40°F regardless of waste gas flow rate. Moisture formed due to gas cooling is removed in the moisture separator, and collected water is periodically discharged automatically. To reduce the potential for waste gas bypass of the gas cooler in the event of valve leakage, a float-operated drain trap is provided which automatically closes on low water level.

The gas leaving the moisture separator is monitored for temperature, and a high alarm alerts the operator to an abnormal condition requiring attention. Oxygen concentration is also monitored. On a high oxygen alarm, a nitrogen purge is automatically injected into the influent line.

The waste gas then flows through the guard bed, where iodine and chemical (oxidizing) contaminants are removed. The guard bed also removes any remaining excessive moisture from the waste gas.

The waste gas then flows through the two delay beds where xenon and krypton are delayed by a dynamic adsorption process. The discharge line is equipped with a valve that automatically closes on either high radioactivity in the gaseous radwaste system discharge line or low ventilation exhaust duct flow.

The adsorption of radioactive gases in the delay bed occurs without reliance on active components or operator action. Operator error or active component failure does not result in an uncontrolled release of radioactivity to the environment. Failure to remove moisture prior to the delay beds (due to loss of chilled water or other causes) results in a gradual reduction in gaseous radwaste system performance. Reduced performance is indicated by high temperature and discharge radiation alarms. High-high radiation automatically terminates discharge.

11.3.2.2 Purge Operations

The gaseous radwaste system is purged with nitrogen gas to expel residual oxygen gas after servicing operations. The system is purged until the effluent from the outlet indicates a low oxygen concentration. The gaseous radwaste system oxygen analyzer is temporarily aligned to monitor the flow in the discharge line. Nitrogen connections are also provided to the sample system and to the system discharge line for purge before and after maintenance operations.

11.3.2.3 Component Description

The general descriptions and summaries of the design basis requirements for the gaseous radwaste system components follow. [Table 11.3-2](#) lists the key design parameters for the gaseous radwaste system components.

The seismic design classification and safety classification for the gaseous radwaste system components are listed in [Section 3.2](#). The components listed are located in the Seismic Category I Nuclear Island.

11.3.2.3.1 Sample Pumps

Two sample pumps are provided. One sample pump normally operates continuously to provide flow through the oxygen analyzers. The other sample pump is periodically used to provide flow from various sample points through a sample cylinder. It is used as a backup to provide flow through the oxygen analyzers.

11.3.2.3.2 Gas Cooler

The gas cooler heat exchanger is designed to cool the gas flow to near the temperature of the chilled water supply (40°F) for efficient moisture removal. The pressure of the gas flow through the gas cooler is less than the chilled water pressure to minimize the potential for contaminating the chilled water system.

11.3.2.3.3 Gaseous Radwaste System Tanks

Moisture Separator

The moisture separator is sized for the design basis purge gas flow rate and is oversized for the lower normal flow rate. The unit includes connections for high and low water level sensors.

Guard Bed

The activated carbon guard bed protects the delay beds from abnormal moisture or chemical contaminants. Under normal operating conditions, the guard bed provides increased delay time for xenon and krypton and removes iodine entering the system.

The flow through the activated carbon bed is downward. A retention screen on the outlet of the guard bed prevents the loss of activated carbon from the unit. Activated carbon can be added to or vacuumed from the unit via a blind flange port.

Delay Beds

Two activated carbon delay beds in series are provided. Together, the beds provide 100 percent of the stated system capacity under design basis conditions. During normal operation a single bed provides adequate performance. This provides operational flexibility to permit continued operation of the gaseous radwaste system in the event of operational upsets in the system that requires isolation of one bed.

The waste gas flows vertically through columns of activated carbon. The activated carbon volume is given in [Table 11.3-1](#).

No retention screens are required on the delay beds since the flow enters and leaves each delay bed at its top.

The guard bed and the delay beds, including supports, in the gaseous radwaste system are designed for seismic loads in conformance with Regulatory Guide 1.143. These are the only AP1000 components used to store or delay the release of gaseous radioactive waste. The beds are located in the seismic Category I auxiliary building at elevation 66'6".

11.3.2.3.4 Remotely Operated Valves

Moisture Separator Level Control Valve

This normally closed, fail-closed globe valve is located in the liquid drain line from the moisture separator outlet line. It maintains the level in the moisture separator by regulating the flow from the moisture separator to the liquid radwaste system. The valve receives a signal to automatically open on a high level in the moisture separator and to close on low level. The valve can also be manually controlled from the gaseous waste panel.

A float-operated drain trap serves as a backup to this valve. This drain trap automatically closes on a low water level in the moisture separator to stop drain flow to the liquid radwaste system in the event of a valve or instrument failure. This prevents waste gas bypass around the gas cooler due to level control valve failure.

Gaseous Radwaste System Discharge Isolation Valve

This normally closed, fail-closed globe valve is at the outlet of the system. [The valve opens during operation of the system as shown in Figure 11.3-1](#). The valve is interlocked to close on a high-high radiation signal in the gaseous radwaste system discharge line to prevent the release of radioactivity in the event of a gaseous radwaste system failure. The valve also receives a signal to automatically close in the event of a low ventilation system exhaust flow rate which prevents accumulation of a flammable or explosive concentration of hydrogen in the aerated vent line.

Manual control is provided on the gaseous radwaste panel.

Nitrogen Purge Pressure Control Valve

This is a self-contained pressure regulating valve in the nitrogen purge line. It is set to maintain a small positive pressure in the gaseous radwaste system to prevent ingress of air during periods of low flow.

11.3.3 Radioactive Releases

Releases of radioactive effluent by way of the atmospheric pathway occur due to:

- Venting of the containment which contains activity as a result of leakage of reactor coolant and as a result of activation of naturally occurring Ar-40 in the atmosphere to form radioactive Ar-41
- Ventilation discharges from the auxiliary building which contains activity as a result of leakage from process streams
- Ventilation discharges from the turbine building
- Condenser air removal system (gaseous activity entering the secondary coolant as a result of primary to secondary leakage is released via this pathway)
- Gaseous radwaste system discharges.

These releases are on-going throughout normal plant operations. There is no gaseous waste holdup capability in the gaseous waste management system and thus no criteria are required for determining the timing of releases or the release rates to be used.

There are no gaseous effluent site interface parameters outside of the Westinghouse scope.

11.3.3.1 Discharge Requirements

The release of radioactive gaseous and particulate effluents to the atmosphere may not exceed the concentration limits specified in [Reference 1](#) nor may the releases result in the annual offsite dose limits specified in 10 CFR 50, Appendix I ([Reference 2](#)) being exceeded.

11.3.3.2 Estimated Annual Releases

The annual average airborne releases of radionuclides from the plant are determined using the PWR-GALE code ([Reference 3](#)). The GALE code models releases using realistic source terms derived from data obtained from the experience of many operating pressurized water reactors. The code input parameters used in the analysis to model the AP1000 plant are provided in [Table 11.2-6](#). The expected annual releases for a single unit site are presented in [Table 11.3-3](#).

To demonstrate compliance with the effluent concentration limits in [Reference 1](#), the expected releases from [Table 11.3-3](#) are used to determine the annual average concentration at the site boundary, and the results are compared with the [Reference 1](#) concentration limits for unrestricted areas in [Table 11.3-4](#). As shown in [Table 11.3-4](#), the overall fraction of the effluent concentration limit for the expected releases is 0.030, which is significantly below the allowable value of 1.0.

11.3.3.3 Release Points

Airborne effluents are normally released through the plant vent or the turbine building vent. The plant vent provides the release path for containment venting releases, auxiliary building ventilation releases, annex building releases, radwaste building releases, and gaseous radwaste system discharge. The turbine building vents provide the release path for the condenser air removal system, gland seal condenser exhaust and the turbine building ventilation releases.

11.3.3.4 Estimated Doses

11.3.3.4.1 Exposure Pathways

Small quantities of radioactive gases would be discharged to the environment during normal operation of the new units. VEGP Units 3 and 4 airborne effluents are normally released through the

plant vent or the turbine building vent. The plant vent is the release pathway for ventilation flows and discharges from the containment, the auxiliary building, the annex building, the radwaste building, and the gaseous radwaste system. The turbine building vents provide the release path for the condenser air removal system, gland seal condenser exhaust, and the turbine building ventilation releases (Reference 207). The impact of these releases on individuals and the population in the vicinity of the new units is evaluated by considering the most important pathways from the release to the receptors of interest. The major pathways are those that could yield the highest radiological doses for a given receptor. The relative importance of a pathway is based on the type and amount of radioactivity released, the environmental transport mechanism, and the consumption or usage factors at the receptor.

The exposure pathways considered and the analytical methods used to estimate doses to the maximally exposed individual (MEI) and to the population surrounding the new units are based on NRC Regulatory Guide 1.109, *Calculation of Annual Doses to Man from Routine Releases of Reactor Effluents for the Purpose of Evaluating Compliance with 10 CFR 50, Appendix I*, Revision 1, October 1977 and NRC Regulatory Guide 1.111, *Methods for Estimating Atmospheric Transport and Dispersion of Gaseous Effluents in Routine Releases from Light-Water-Cooled Reactors*, Revision 1, July 1977. An MEI is a member of the public located to receive the maximum possible calculated dose. The MEI allows dose comparisons with established criteria for the public.

The NRC-endorsed GASPAR II computer program (Reference 203) is used to calculate the doses to offsite receptors from the new units. This program implements the radiological exposure models described in Regulatory Guide 1.109 to estimate the doses resulting from radioactive releases in gaseous effluent. The atmospheric dispersion component of the analysis is calculated with the NRC-sponsored program XOQDOQ (Reference 201). Dispersion and deposition factors are calculated from onsite meteorological parameters (wind speed, wind direction, stability class) for 1998-2002. Subsection 2.3.5 shows dispersion data for the locations shown in Table 11.3-204 as well as deposition and undecayed/undepleted dispersion factors within 50 miles of the plant. Decayed/undepleted and decayed/depleted dispersion factors within 50 miles are calculated using the same methodology as presented in Subsection 2.3.5.

The following exposure pathways are considered in GASPAR II:

- External exposure to airborne plume
- External exposure to contaminated ground
- Inhalation of airborne activity
- Ingestion of contaminated vegetables
- Ingestion of contaminated meat

The input parameters for the gaseous pathway are presented in Tables 11.3-201, 11.3-202, and 11.3-203 and the receptor locations are shown in Table 11.3-204.

11.3.3.4.2 Gaseous Pathway Doses

Based on the parameters in Tables 11.3-201 to 11.3-203, the GASPAR II computer program is used to calculate doses to the maximally exposed adult, teenager, child, and infant at the following locations:

- Nearest site boundary

- Nearest residence
- Nearest vegetable garden
- Nearest meat animal

The gaseous activity releases (source terms) for the two proposed AP1000 units are obtained from [Table 11.3-3](#) and are shown in [Table 11.3-203](#). These are conservative, projected values that were calculated using the PWR-GALE computer code ([Reference 202](#)). [Table 11.3-203](#) also shows the maximum measured activity releases for Units 1 and 2, based on information presented in the annual effluent reports ([References 204, 205, 206](#)). Projected activity concentrations at the site boundary are based on the calculated activity releases for Units 3 and 4 as well as the measured activity releases from Units 1 and 2. The concentrations are within the limits of 10 CFR 20, Appendix B, Table 2, Column 1. The calculated annual doses to the MEI are presented in [Table 11.3-205](#).

[Table 11.3-206](#) shows that the doses to the MEI from the liquid effluents of a new unit meet the design objectives of 10 CFR 50, Appendix I. The total site doses due to liquid and gaseous effluents from the two existing units and the two new units would be well within the regulatory limits of 40 CFR 190, as shown in [Table 11.3-207](#). Since 40 CFR 190 is more restrictive than 10 CFR 20.1301, compliance with the limits of 40 CFR 190 also demonstrates compliance with the 0.1 rem limit of 10 CFR 20.1301. [Table 11.3-208](#) shows the doses from the new and existing units to the population within 50 miles of the ESP site. The doses from the proposed units are much higher than from the existing units because doses from the existing units are more realistic, based on measurements, whereas the doses from the proposed units are based on conservative calculations.

[Table 11.3-208](#) reports a total body population dose from gaseous effluents within 50 miles of VEGP Units 3 and 4 of 1.8 person-rem/year or 0.9 person-rem/per reactor. In addition, the corresponding thyroid dose has been calculated to be 3.0 person-rem/year per reactor.

11.3.3.4.3 Gaseous Radwaste Cost-Benefit Analysis Methodology

The guidance for performing cost-benefit analysis for the gaseous radwaste system is similar to that used and described for the liquid radwaste system in [Section 11.2](#). The gaseous radwaste treatment system augments annual costs were determined and the lowest annual cost considered a threshold value. The lowest-cost option for gaseous radwaste treatment system augments is the Steam Generator Flash Tank Vent to Main Condenser at \$6,320 per year, which yields a threshold value of 6.32 person-rem total body or thyroid from gaseous effluents.

For AP1000 sites with population dose estimates less than 6.32 person-rem total body or thyroid dose from gaseous effluents, no further cost-benefit analysis is needed to demonstrate compliance with 10 CFR 50, Appendix I, Section II.D.

11.3.3.4.4 Gaseous Radwaste Cost-Benefit Analysis

As discussed in [Subsection 11.3.3.4.3](#), the lowest cost gaseous radwaste system augment is \$6,320. Assuming 100 percent efficiency of this augment, the minimum possible cost per person-rem is determined by dividing the cost of the augment by the population dose. This is \$7,022 per person-rem total body ($\$6,320/0.9$ person-rem) and \$2,107 per person-rem thyroid ($\$6,320/3.0$ person-rem thyroid). These costs per person-rem reduction exceed the \$1,000 per person-rem criterion prescribed in Appendix I to 10 CFR Part 50 and are therefore not cost beneficial.

11.3.3.5 Maximum Release Concentrations

The annual releases of radioactive gases and iodine provided in [Table 11.3-3](#) represent expected releases from the plant and reflect an expected level of fuel cladding defects. If the plant operates with the maximum defined fuel defect level, the releases would be substantially greater. The maximum defined fuel defect level corresponds to the Technical Specification limit on coolant activity which is based on 0.25 percent fuel defects. To demonstrate compliance with the effluent concentration limits of [Reference 1](#), the releases from [Table 11.3-3](#) have been adjusted to reflect operation with the maximum defined fuel defect level, and the resulting airborne radionuclide concentrations at the site boundary are compared in [Table 11.3-4](#) with the [Reference 1](#) limits for concentrations in unrestricted areas. As shown in [Table 11.3-4](#), the overall fraction of the effluent concentration limit for operation with the maximum defined fuel defect level is 0.33, which is well below the allowable value of 1.0.

11.3.3.6 Quality Assurance

The quality assurance program for design, fabrication, procurement, and installation of the gaseous radwaste system is in accordance with the overall quality assurance program described in [Chapter 17](#).

Since the impact of radwaste systems on safety is limited, the extent of control required by Appendix B to 10 CFR Part 50 is similarly limited. Thus, a supplemental quality assurance program applicable to design, construction, installation, and testing provisions of the gaseous radwaste system is established by procedures that complies with the guidance presented in Regulatory Guide 1.143.

11.3.4 Inspection and Testing Requirements

11.3.4.1 Preoperational Testing

Preoperational tests are performed to verify the proper operation of the WGS. The operational tests include automatic closure of the discharge control/isolation valve, WGS-PL-V051, upon receipt of a simulated high radiation signal. The discharge line of the gaseous radwaste system includes a radiation monitor, WGS-RE017, which detects a high radiation condition and generates an alarm that automatically closes the discharge control/isolation valve. By imposing a simulated high radiation alarm signal, proper operation of the discharge control/isolation valve is confirmed by its closure.

11.3.4.2 Preoperational Inspection

The proper performance of the gaseous radwaste system depends upon delay of gaseous radionuclides by chemical adsorption on activated carbon. As the radionuclides are delayed, they decay and are no longer available for release to the environment. The rate of release and site boundary dose rates have been evaluated based upon the quantity of activated carbon in a delay bed being at least 80 cubic feet. An inspection of the gaseous radwaste system activated carbon delay beds, WGS-MV01A and WGS-MV02B, will confirm that the contained volume of each delay bed is at least 80 cubic feet.

11.3.5 Combined License Information

11.3.5.1 Cost Benefit Analysis of Population Doses

The site specific cost-benefit analysis to demonstrate compliance with 10 CFR 50, Appendix I, regarding population doses due to gaseous effluents is addressed in [Subsections 11.3.3.4, 11.3.3.4.3 and 11.3.3.4.4](#).

11.3.5.2 Identification of Adsorbent Media

The types of adsorbent media to be used in the gaseous radwaste system is addressed in APP-GW-GLR-008 (Reference 5).

11.3.6 References

1. "Annual Limits on Intake (ALIs) and Derived Air Concentrations (DACs) of Radionuclides for Occupational Exposure; Effluent Concentrations; Concentrations for Release to Sewerage," 10 CFR Part 20, Appendix B, Issued by 58 FR 67657, April 28, 1995.
2. "Numerical Guides for Design Objectives and Limiting Conditions for Operation to Meet the Criterion >As-Low-As-Is-Reasonably-Achievable= for Radioactive Material in Light-Water-Cooled Nuclear Power Reactor Effluents," 10 CFR Part 50, Appendix I.
3. "Calculation of Releases of Radioactive Materials in Gaseous and Liquid Effluents from Pressurized Water Reactors (PWR-GALE Code)," NUREG-0017, Revision 1, March 1985.
4. "Minimization of Contamination," 10 CFR 20.1406.
5. APP-GW-GLR-008, "Request for Closure of COL Items in DCD Chapter 11, Identification for Adsorbent Media," Westinghouse Electric Company LLC.
201. **(NRC 1982)** NUREG/CR-2919, *XOQDOQ: Computer Program for the Meteorological Evaluation of Routine Effluent Releases at Nuclear Power Stations Final Report*, U. S. Nuclear Regulatory Commission, 1982.
202. **(NRC 1985)** NUREG-0017, *Calculation of Releases of Radioactive Materials in Gaseous and Liquid Effluents from Pressurized Water Reactors (PWR-GALE Code)*, Revision 1, U. S. Nuclear Regulatory Commission, 1985.
203. **(NRC 1987)** NUREG/CR-4653, *GASPAR II Technical Reference and User Guide*, U. S. Nuclear Regulatory Commission, 1987.
204. **(SNC 2002)** *Annual Radioactive Effluent Release Report for January 1, 2001 to December 31, 2001*, Southern Nuclear Company, 2002.
205. **(SNC 2003)** *Annual Radioactive Effluent Release Report for January 1, 2002 to December 31, 2002*, Southern Nuclear Company, 2003.
206. **(SNC 2004)** *Annual Radioactive Effluent Release Report for January 1, 2003 to December 31, 2003*, Southern Nuclear Company, 2004.
207. **(Westinghouse 2005)** AP1000 Document APP-GW-GL-700, *AP1000 Design Control Document, Tier 2 Material*, Revision 15, Westinghouse Electric Company, 2005.

Table 11.3-1
Gaseous Radwaste System Parameters

Design operating influent pressure (psig)	2
Design influent flow rate (scfm)	0.5
Activated carbon bed design operating temperature (°F)	77
Activated carbon bed design operating dew point (°F)	45
Activated carbon in delay beds (average) (pounds combined total)	4600

**Table 11.3-2 (Sheet 1 of 2)
Component Data (Nominal) — Gaseous Radwaste System**

Mechanical Components		
Pumps Sample Pumps Number Type	2 Diaphragm	
Heat Exchangers Gas Cooler Number Type	1 Dual tube coil	
	Process Side	Cooling Side
Design pressure (psig) Design temperature (°F) Design flow Temperature inlet (°F) Temperature outlet (°F) Material	150 200 1.0 scfm 125 40.1 Stainless steel	150 200 0.15 gpm 40 42 Stainless steel
Tanks Guard Bed Number Nominal volume (ft ³) Type Design pressure (psig) Design temperature (°F) Material	1 8 Vertical pipe 100 150 Stainless steel	
Delay Bed Number Nominal volume (ft ³) Type Design pressure (psig) Design temperature (°F) Material	2 80 Vertical serpentine 100 200 Carbon steel	
Moisture Separator Number Nominal volume (gal) Type Design pressure (psig) Design temperature (°F) Material	1 3 Vertical 150 200 Stainless steel	

Table 11.3-2 (Sheet 2 of 2)
Component Data (Nominal) — Gaseous Radwaste System
Summary of Instrument Indication and Alarms

Instrumentation	Indicate (Note 4)	Alarm
Gas Cooler		
Gas inlet temperature	X	
Cooling water outlet temperature	X	
Gas inlet pressure	X	X – Hi
Carbon Guard Bed		
Gas inlet temperature	X	X – Hi
Carbon Delay Beds		
Gas inlet temperature	X	X – Hi
Gas outlet temperature 2 channels	X	X – Hi
Gas outlet flow	X	
Gas outlet radiation (Note 3)	X	X – Hi
Gas outlet pressure	X	
Carbon Bed Vault		
Vault hydrogen (Note 2)	X	X – Hi
Vault temperature (Note 1)	X	X – Hi
Moisture Separator		
Water level	X	X – Hi
Sampling Subsystem		
Hydrogen concentration	X	X
Oxygen concentration 2 channels	X	X – Hi
Gas flow	X	X – Lo

Notes:

- Vault temperature monitor common for guard bed and delay bed.
- Vault hydrogen monitor common for guard bed and delay bed.
- High outlet radiation alarm closes gas outlet isolation valve.
- Monitoring of the gaseous radwaste system is performed through the data display and processing system. Control functions are performed by the plant control system. Appropriate alarms and displays are available in the control room. Local indication and control are available on portable displays which may be connected to the data display and processing system. See [Chapter 7](#).

**Table 11.3-3 (Sheet 1 of 3)
 Expected Annual Average Release of Airborne Radionuclides
 as Determined by the PWR-GALE Code, Revision 1
 (Release Rates in Ci/yr)**

Noble Gases ⁽¹⁾	Waste Gas System	Building/Area Ventilation			Condenser Air Removal System	Total
		Cont.	Auxiliary Building	Turbine Building		
Kr-85m	0.	3.0E+01	4.0E+00	0.	2.0E+00	3.6E+01
Kr-85	1.65E+03	2.4E+03	2.9E+01	0.	1.4E+01	4.1E+03
Kr-87	0.	9.0E+00	4.0E+00	0.	2.0E+00	1.5E+01
Kr-88	0.	3.4E+01	8.0E+00	0.	4.0E+00	4.6E+01
Xe-131m	1.42E+02	1.6E+03	2.3E+01	0.	1.1E+01	1.8E+03
Xe-133m	0.	8.5E+01	2.0E+00	0.	0.	8.7E+01
Xe-133	3.0E+01	4.5E+03	7.6E+01	0.	3.6E+01	4.6E+03
Xe-135m	0.	2.0E+00	3.0E+00	0.	2.0E+00	7.0E+00
Xe-135	0.	3.0E+02	2.3E+01	0.	1.1E+01	3.3E+02
Xe-138	0.	1.0E+00.	3.0E+00	0.	2.0E+00	6.0E+00
					Total	1.1E+04
Additionally:						
H-3 released via gaseous pathway						350
C-14 released via gaseous pathway						7.3
Ar-41 released via containment vent						34

**Table 11.3-3 (Sheet 2 of 3)
 Expected Annual Average Release of Airborne Radionuclides
 as Determined by the PWR-GALE Code, Revision 1
 (Release Rates in Ci/yr)**

Iodines ⁽¹⁾	Fuel Handling Area ⁽²⁾	Building/Area Ventilation			Condenser Air Removal System	Total
		Cont.	Auxiliary Building	Turbine Building		
I-131	4.5E-03	2.3E-03	1.1E-01	0.	0.	1.2E-01
I-133	1.6E-02	5.5E-03	3.8E-01	2.0E-04	0.	4.0E-01

Table 11.3-3 (Sheet 3 of 3)
Expected Annual Average Release of Airborne Radionuclides
as Determined by the PWR-GALE Code, Revision 1
(Release Rates in Ci/yr)

Radionuclide ⁽¹⁾	Waste Gas System	Building/Area Ventilation			Total
		Cont.	Auxiliary Building	Fuel Handling Area ⁽²⁾	
Cr-51	1.4E-05	9.2E-05	3.2E-04	1.8E-04	6.1E-04
Mn-54	2.1E-06	5.3E-05	7.8E-05	3.0E-04	4.3E-04
Co-57	0.	8.2E-06	0.	0.	8.2E-06
Co-58	8.7E-06	2.5E-04	1.9E-03	2.1E-02	2.3E-02
Co-60	1.4E-05	2.6E-05	5.1E-04	8.2E-03	8.7E-03
Fe-59	1.8E-06	2.7E-05	5.0E-05	0.	7.9E-05
Sr-89	4.4E-05	1.3E-04	7.5E-04	2.1E-03	3.0E-03
Sr-90	1.7E-05	5.2E-05	2.9E-04	8.0E-04	1.2E-03
Zr-95	4.8E-06	0.	1.0E-03	3.6E-06	1.0E-03
Nb-95	3.7E-06	1.8E-05	3.0E-05	2.4E-03	2.5E-03
Ru-103	3.2E-06	1.6E-05	2.3E-05	3.8E-05	8.0E-05
Ru-106	2.7E-06	0.	6.0E-06	6.9E-05	7.8E-05
Sb-125	0.	0.	3.9E-06	5.7E-05	6.1E-05
Cs-134	3.3E-05	2.5E-05	5.4E-04	1.7E-03	2.3E-03
Cs-136	5.3E-06	3.2E-05	4.8E-05	0.	8.5E-05
Cs-137	7.7E-05	5.5E-05	7.2E-04	2.7E-03	3.6E-03
Ba-140	2.3E-05	0.	4.0E-04	0.	4.2E-04
Ce-141	2.2E-06	1.3E-05	2.6E-05	4.4E-07	4.2E-05

Notes:

1. The appearance of 0. in the table indicates less than 1.0 Ci/yr for noble gas or less than 0.0001 Ci/yr for iodine. For particulates, release is not observed and assumed less than 1 percent of the total particulate releases.
2. The fuel handling area is within the auxiliary building but is considered separately.

Table 11.3-4 (Sheet 1 of 2)
Comparison of Calculated Offsite Airborne Concentrations with 10 CFR 20 Limits

Radionuclide	Effluent Concentration Limit $\mu\text{Ci/ml}^{(a)}$	Expected Site Boundary Concentration Limit $\mu\text{Ci/ml}$	Fraction of Concentration Limit ^(b) (expected)	Maximum Site Boundary Concentration Limit $\mu\text{Ci/ml}^{(c)}$	Fraction of Concentration Limit ^(c) (maximum)
Kr-85m	1.0E-07	2.9E-11	2.9E-04	1.2E-10	1.2E-03
Kr-85	7.0E-07	3.3E-09	4.6E-03	6.9E-09	9.9E-03
Kr-87	2.0E-08	1.2E-11	5.9E-04	3.0E-11	1.5E-03
Kr-88	9.0E-09	3.6E-11	4.1E-03	1.5E-10	1.7E-02
Xe-131m	2.0E-06	1.4E-09	7.1E-04	1.7E-09	8.7E-04
Xe-133m	6.0E-07	6.9E-11	1.1E-04	1.3E-09	2.1E-03
Xe-133	5.0E-07	3.6E-09	7.3E-03	1.3E-07	2.5E-01
Xe-135m	4.0E-08	5.5E-12	1.4E-04	5.9E-12	1.5E-04
Xe-135	7.0E-08	2.6E-10	3.7E-03	8.5E-10	1.2E-02
Xe-138	2.0E-08	4.8E-12	2.4E-04	7.7E-12	3.8E-04
I-131	2.0E-10	9.5E-14	4.8E-04	2.0E-12	9.8E-03
I-133	1.0E-09	3.2E-13	3.2E-04	3.4E-12	3.4E-03
H-3	1.0E-07	2.8E-10	2.8E-03	2.8E-10	2.8E-03
C-14	3.0E-09	5.8E-12	1.9E-03	5.8E-12	1.9E-03
Ar-41	1.0E-08	2.7E-11	2.7E-03	2.7E-11	2.7E-03
Cr-51	3.0E-08	4.8E-16	1.6E-08	4.8E-16	1.6E-08
Mn-54	1.0E-09	3.4E-16	3.4E-07	3.4E-16	3.4E-07
Co-57	9.0E-10	6.5E-18	7.2E-09	6.5E-18	7.2E-09
Co-58	1.0E-09	1.8E-14	1.8E-05	1.8E-14	1.8E-05
Co-60	5.0E-11	6.9E-15	1.4E-04	6.9E-15	1.4E-04
Fe-59	5.0E-10	6.3E-17	1.3E-07	6.3E-17	1.3E-07
Sr-89	2.0E-10	2.4E-15	1.2E-05	9.9E-14	4.9E-04
Sr-90	6.0E-12	9.5E-16	1.6E-04	2.1E-14	3.5E-03
Zr-95	4.0E-10	7.9E-16	2.0E-06	1.7E-15	4.4E-06
Nb-95	2.0E-09	2.0E-15	9.9E-07	6.1E-15	3.0E-06
Ru-103	9.0E-10	6.3E-17	7.0E-08	6.3E-17	7.0E-08

**Table 11.3-4 (Sheet 2 of 2)
Comparison of Calculated Offsite Airborne Concentrations with 10 CFR 20 Limits**

Radionuclide	Effluent Concentration Limit $\mu\text{Ci/ml}^{(a)}$	Expected Site Boundary Concentration Limit $\mu\text{Ci/ml}$	Fraction of Concentration Limit ^(b) (expected)	Maximum Site Boundary Concentration Limit $\mu\text{Ci/ml}^{(c)}$	Fraction of Concentration Limit ^(c) (maximum)
Ru-106	2.0E-11	6.2E-17	3.1E-06	9.9E-16	4.9E-05
Sb-125	7.0E-10	4.8E-17	6.9E-08	4.8E-16	6.9E-07
Cs-134	2.0E-10	1.8E-15	9.1E-06	9.5E-13	4.7E-03
Cs-136	9.0E-10	6.7E-17	7.5E-08	4.1E-13	4.6E-04
Cs-137	2.0E-10	2.9E-15	1.4E-05	8.1E-13	4.0E-03
Ba-140	2.0E-09	3.3E-16	1.7E-07	3.3E-16	1.7E-07
Ce-141	8.0E-10	3.3E-17	4.2E-08	1.9E-16	2.3E-07
			Total = 3.0E-02		Total = 3.3E-01

Notes:

- (a) Effluent concentration limit is from [Reference 1](#).
- (b) Expected site boundary concentration based on annual releases predicted by the PWR-GALE code ([Table 11.3-3](#)) and an annual average X/Q of 2.0×10^{-5} seconds per cubic meter.
- (c) Maximum site boundary concentration based on adjusting the releases predicted by the PWR-GALE code ([Table 11.3-3](#)) to reflect operation with maximum defined fuel defect level and an annual average X/Q of 2.0×10^{-5} seconds per cubic meter.

**Table 11.3-201
Gaseous Pathway Parameters**

Parameter	Value
Release source terms	Table 11.3-203
Population distribution	Figures 2.1-203 & 2.1-210
Milk production rate within 50 miles	6.37E+07 l/yr ^a
Meat production rate within 50 miles	1.03E+07 kg/yr ^a
Vegetable production rate within 50 miles	6.57E+07 kg/yr ^a
Atmospheric dispersion factors	Table 2.3-219
Ground deposition factors	Table 2.3-219

^a Animal and vegetable production from 2002 National Census of Agriculture. Production converted to food products using average conversion factors: 17,050 lb milk/cow; 377 lb beef/cow, calf; 81.2 lb meat/hog, pig; 95.8 lb meat/sheep, and 8,090 kg vegetables/acre.

**Table 11.3-202
Gaseous Pathway Consumption Factors for Maximally Exposed Individual**

Consumption Factor	Annual Rate			
	Adult	Teen	Child	Infant
Leafy vegetable consumption (kg/yr)	64	42	26	0
Meat consumption (kg/yr)	110	65	41	0
Vegetable/fruit consumption (kg/yr)	520	630	520	0

Note: These are obtained from Regulatory Guide 1.109. Leafy vegetables are assumed to be grown in the MEI's garden 58% of the year.

**Table 11.3-203 (Sheet 1 of 2)
Release of Activities in Gaseous Effluent**

Isotope	Release (Ci/yr)			Concentration (µCi/ml)		Fraction of ECL
	Units 3 & 4	Units 1 & 2	Total	Site	ECL	
H-3	7.0E+02	2.0E+02	9.0E+02	1.6E-10	1.0E-07	1.6E-03
Be-7	-	7.0E-06	7.0E-06	1.2E-18	3.0E-08	4.1E-11
C-14	1.5E+01	-	1.5E+01	2.5E-12	3.0E-09	8.5E-04
Ar-41	6.8E+01	1.6E+00	7.0E+01	1.2E-11	1.0E-08	1.2E-03
Cr-51	1.2E-03	3.2E-06	1.2E-03	2.1E-16	3.0E-08	7.1E-09
Mn-54	8.6E-04	-	8.6E-04	1.5E-16	1.0E-09	1.5E-07
Fe-59	1.6E-04	-	1.6E-04	2.8E-17	5.0E-10	5.5E-08
Co-57	1.6E-05	-	1.6E-05	2.9E-18	9.0E-10	3.2E-09
Co-58	4.6E-02	5.9E-06	4.6E-02	8.0E-15	1.0E-09	8.0E-06
Co-60	1.7E-02	9.6E-06	1.7E-02	3.0E-15	5.0E-11	6.1E-05
Kr-85m	7.2E+01	3.8E-05	7.2E+01	1.3E-11	1.0E-07	1.3E-04
Kr-85	8.2E+03	3.4E+00	8.2E+03	1.4E-09	7.0E-07	2.0E-03
Kr-87	3.0E+01	-	3.0E+01	5.2E-12	2.0E-08	2.6E-04
Kr-88	9.2E+01	-	9.2E+01	1.6E-11	9.0E-09	1.8E-03
Sr-89	6.0E-03	1.1E-06	6.0E-03	1.0E-15	2.0E-10	5.2E-06
Sr-90	2.4E-03	4.5E-08	2.4E-03	4.2E-16	6.0E-12	7.0E-05
Zr-95	2.0E-03	-	2.0E-03	3.5E-16	4.0E-10	8.7E-07
Nb-95	5.0E-03	6.2E+00	6.2E+00	1.1E-12	2.0E-09	5.4E-04
I-131	2.4E-01	2.1E-02	2.6E-01	4.5E-14	2.0E-10	2.3E-04
I-132	-	3.6E-06	3.6E-06	6.2E-19	2.0E-08	3.1E-11
I-133	8.0E-01	4.9E-04	8.0E-01	1.4E-13	1.0E-09	1.4E-04
Xe-131m	3.6E+03	1.1E-01	3.6E+03	6.3E-10	2.0E-06	3.1E-04
Xe-133m	1.7E+02	3.3E-02	1.7E+02	3.0E-11	6.0E-07	5.1E-05
Xe-133	9.2E+03	2.2E+01	9.2E+03	1.6E-09	5.0E-07	3.2E-03
Xe-135m	1.4E+01	-	1.4E+01	2.4E-12	4.0E-08	6.1E-05
Xe-135	6.6E+02	4.0E-01	6.6E+02	1.2E-10	7.0E-08	1.6E-03
Xe-138	1.2E+01	-	1.2E+01	2.1E-12	2.0E-08	1.0E-04
Ru-103	1.6E-04	-	1.6E-04	2.8E-17	9.0E-10	3.1E-08

**Table 11.3-203 (Sheet 2 of 2)
Release of Activities in Gaseous Effluent**

Isotope	Release (Ci/yr)			Concentration (μCi/ml)		Fraction of ECL
	Units 3 & 4	Units 1 & 2	Total	Site	ECL	
Ru-106	1.6E-04	-	1.6E-04	2.7E-17	2.0E-11	1.4E-06
Sb-125	1.2E-04	-	1.2E-04	2.1E-17	7.0E-10	3.0E-08
Cs-134	4.6E-03	-	4.6E-03	8.0E-16	2.0E-10	4.0E-06
Cs-136	1.7E-04	-	1.7E-04	3.0E-17	9.0E-10	3.3E-08
Cs-137	7.2E-03	2.2E-07	7.2E-03	1.3E-15	2.0E-10	6.3E-06
Ba-140	8.4E-04	-	8.4E-04	1.5E-16	2.0E-09	7.3E-08
Ce-141	8.4E-05	-	8.4E-05	1.5E-17	8.0E-10	1.8E-08
Total	2.3E+04	2.3E+02	2.3E+04	4.0E-09	-	1.4E-02

Note: The releases for Units 3 and 4 are based on the AP1000 DCD (Reference 207) and are for two units. The releases for Units 1 and 2 are based on annual effluent release reports (References 204, 205, 206) and are for two units. The effluent concentration limits (ECLs) are from 10 CFR 20, Appendix B, Table 2, Column 1.

Table 11.3-204
Gaseous Pathway Receptor Locations

Receptor	Direction	Distance (miles)
Nearest site boundary	NE	0.50
Nearest residence	NE	0.67
Nearest vegetable garden	NE	0.67
Nearest meat animal	NE	0.67

Note: This data is taken from [Table 2.3-219](#). There are no milk cows or goats within 5 miles of the plant.

**Table 11.3-205
Gaseous Pathway Doses for Maximally Exposed Individuals**

Location	Pathway		Dose per Unit (mrem/yr)			
			Total Body	Thyroid	Bone	Skin
Nearest Site Boundary (0.50 mi NE)	Plume		4.1E-01	4.1E-01	4.1E-01	2.1E+00
		Ground	1.5E-01	1.5E-01	1.5E-01	1.8E-01
	Inhalation	Adult	4.5E-02	4.3E-01	7.1E-03	4.4E-02
		Teen	4.6E-02	5.3E-01	8.6E-03	4.4E-02
		Child	4.1E-02	6.2E-01	1.1E-02	3.9E-02
		Infant	2.3E-02	5.6E-01	5.3E-03	2.3E-02
Nearest Residence (0.67 mi NE)	Plume		2.6E-01	2.6E-01	2.6E-01	1.3E+00
		Ground	8.7E-02	8.7E-02	8.7E-02	1.0E-01
	Inhalation	Adult	2.8E-02	2.6E-01	4.3E-03	2.7E-02
		Teen	2.8E-02	3.2E-01	5.2E-03	2.7E-02
		Child	2.5E-02	3.8E-01	6.3E-03	2.4E-02
		Infant	1.4E-02	3.4E-01	3.2E-03	1.4E-02
Nearest Garden (0.67 mi NE)	Vegetable	Adult	2.0E-01	2.0E+00	9.9E-01	1.8E-01
		Teen	3.0E-01	2.7E+00	1.6E+00	2.8E-01
		Child	6.7E-01	5.2E+00	3.6E+00	6.3E-01
Nearest Meat Animal (0.67 mi NE)	Meat	Adult	6.2E-02	1.5E-01	2.7E-01	6.0E-02
		Teen	5.0E-02	1.2E-01	2.3E-01	4.9E-02
		Child	9.1E-02	1.9E-01	4.3E-01	8.9E-02
Maximally Exposed Individual (0.67 mi NE)	Internal Only	Adult	2.9E-01	2.4E+00	1.3E+00	2.7E-01
		Teen	3.8E-01	3.1E+00	1.8E+00	3.5E-01
		Child	7.8E-01	5.8E+00	4.1E+00	7.4E-01
		Infant	1.4E-02	3.4E-01	3.2E-03	1.4E-02
	Total	Adult	6.4E-01	2.8E+00	1.6E+00	1.7E+00
		Teen	7.2E-01	3.5E+00	2.1E+00	1.7E+00
		Child	1.1E+00	6.1E+00	4.4E+00	2.1E+00
		Infant	3.6E-01	6.8E-01	3.5E-01	1.4E+00

Note: The internal doses for the maximally exposed individual are obtained by adding the doses from the inhalation, vegetable, and meat pathways. The total doses add the plume and ground doses to the internal doses.

**Table 11.3-206
Comparison of Maximally Exposed Individual Doses with 10 CFR 50, Appendix I Criteria**

Dose Type	Location	Dose per Unit	
		Estimated	Limit
Gamma Air (mrad)	Site Boundary	0.67	10
Beta Air (mrad)	Site Boundary	2.8	20
Total Body (mrem)	Site Boundary	0.56	5
Skin (mrem)	Site Boundary	2.2	15
Iodines and Particulates Maximum Organ - Thyroid (mrem)	Maximally Exposed Individual	5.9	15

Note: Total body and skin doses are the sums of plume and ground doses from Table 11.3-205. The dose due to iodines and particulates is for a child, the age group receiving the maximum total dose.

**Table 11.3-207
Comparison of Maximally Exposed Individual Doses with 40 CFR 190 Criteria**

	Dose (mrem/yr)					
	Units 3 and 4			Units 1 and 2	Site Total	Regulatory Limit
	Liquid	Gaseous	Total			
Total Body	0.020	2.2	2.3	0.092	2.4	25
Thyroid	0.027	12	12	0.069	12	75
Other Organ - Bone	0.023	8.8	8.8	0.054	8.9	25

Note: Doses for Units 3 and 4 are for a child, the age group receiving the maximum total dose. Doses for Units 1 and 2 are the maximum reported in the annual effluent release reports for 2001, 2002, and 2003 (References 204, 205, 206).

**Table 11.3-208
Collective Total Body Doses Within 50 Miles**

	Dose (person-rem/yr)		
	Units 3 and 4	Units 1 and 2	Total
Noble Gases	0.57	0.0011	0.57
Iodines & Particulates	0.14	0.16	0.30
H-3 & C-14	1.1	0.09	1.2
Total	1.8	0.26	2.1

Note: Doses for Units 1 and 2 are based on the maximum activity releases in the annual effluent release reports for 2001, 2002, and 2003 (References 204, 205, 206).

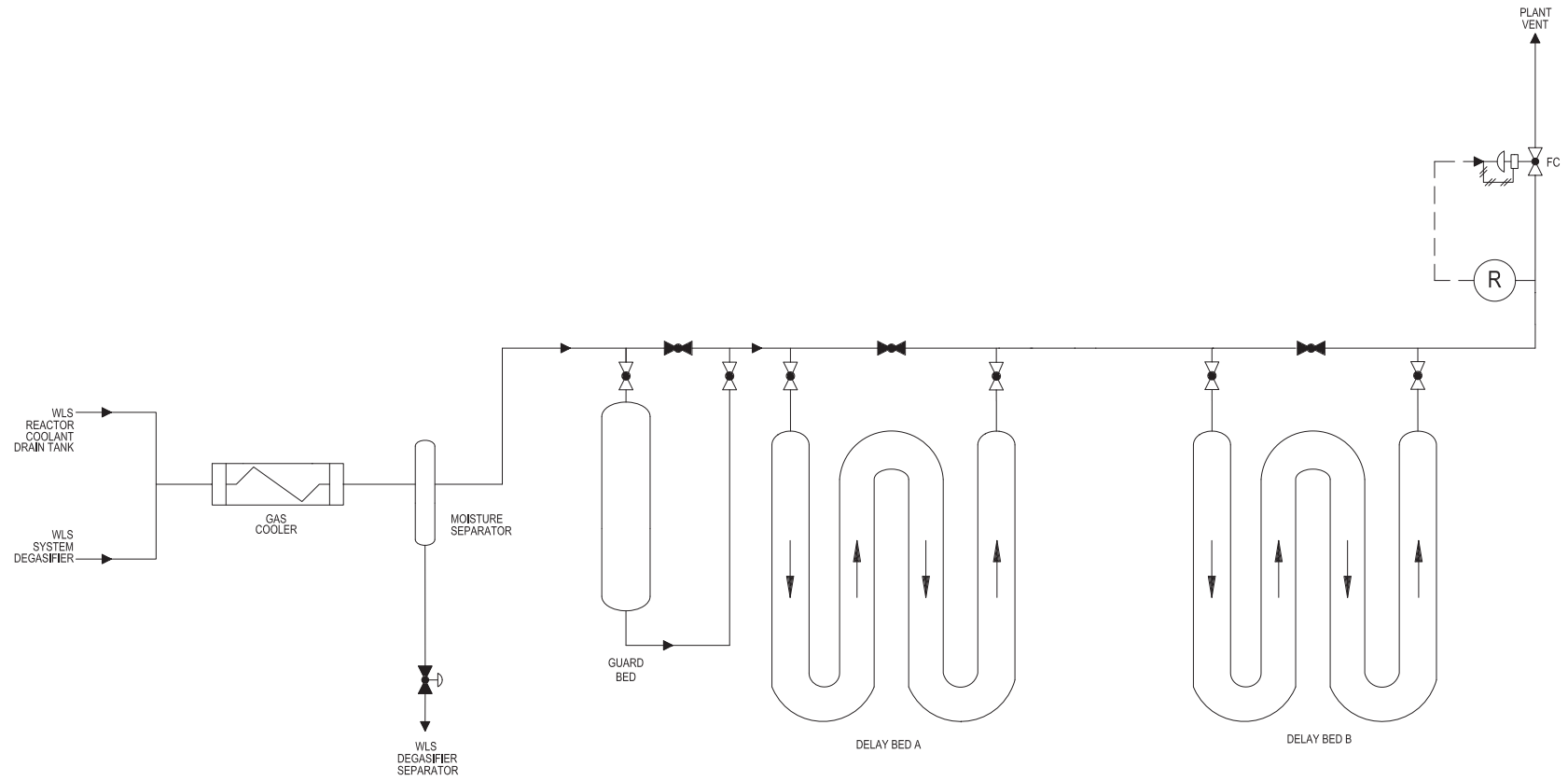

Figure represents system functional arrangement. Details internal to the system may differ as a result of implementation factors such as vendor-specific component requirements.

Figure 11.3-1
Gaseous Radwaste System
Simplified Sketch

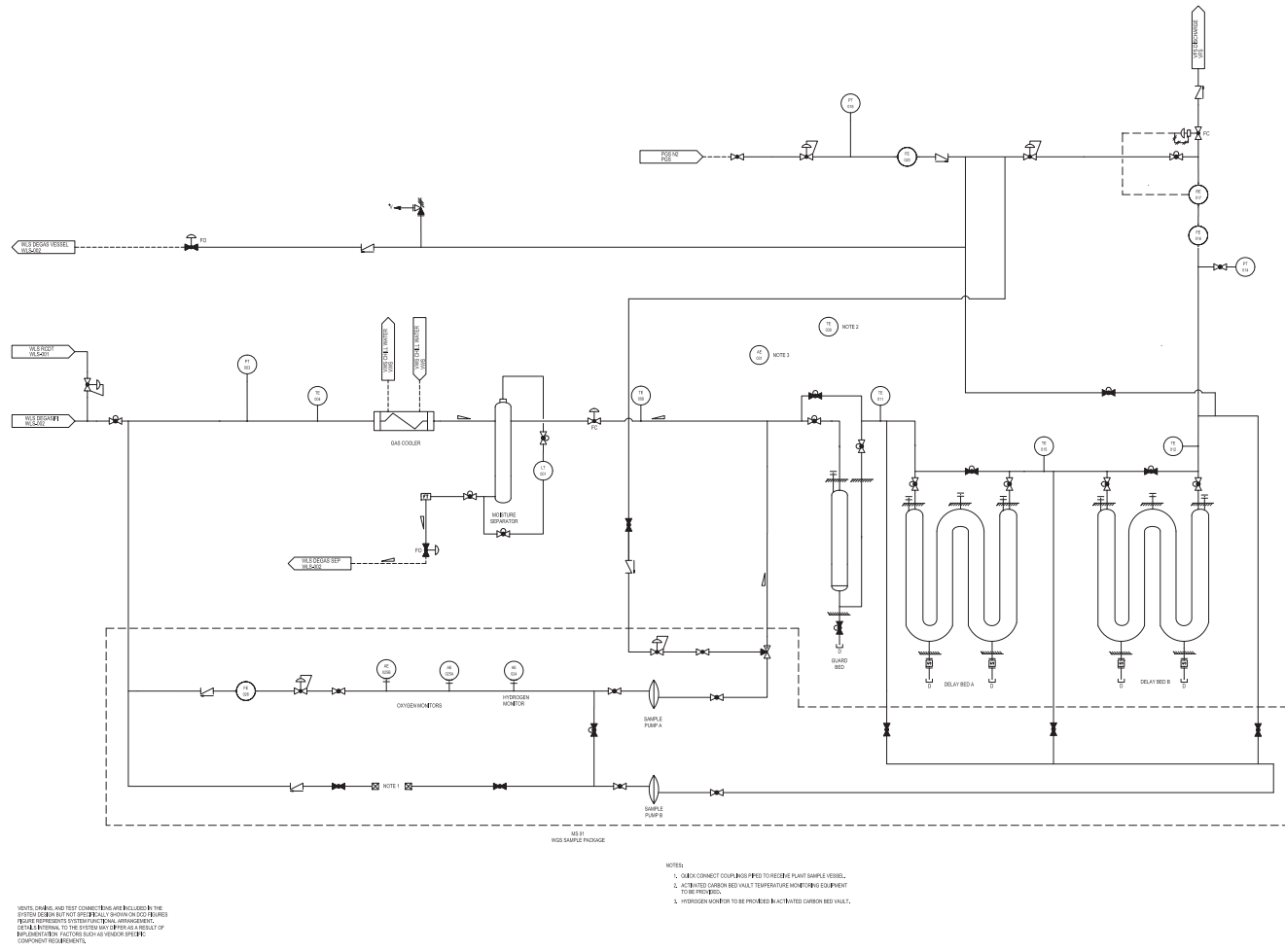

Figure represents system functional arrangement. Details internal to the system may differ as a result of implementation factors such as vendor-specific component requirements.

Figure 11.3-2
Simplified Gaseous Radwaste System
Piping and Instrumentation Diagram
(REF) WGS 001

11.4 Solid Waste Management

The solid waste management system (WSS) is designed to collect and accumulate spent ion exchange resins and deep bed filtration media, spent filter cartridges, dry active wastes, and mixed wastes generated as a result of normal plant operation, including anticipated operational occurrences. The system is located in the auxiliary and radwaste buildings. Processing and packaging of wastes are by mobile systems in the auxiliary building rail car bay and in the mobile systems facility part of the radwaste building. The packaged waste is stored in the auxiliary and radwaste buildings until it is shipped offsite to a licensed disposal facility.

The use of mobile systems for the processing functions permits the use of the latest technology and avoids the equipment obsolescence problems experienced with installed radwaste processing equipment. The most appropriate and efficient systems may be used as they become available.

This system does not handle large, radioactive waste materials such as core components or radioactive process wastes from the plant's secondary cycle. However, the volumes and activities of the secondary cycle wastes are provided in this section.

11.4.1 Design Basis

11.4.1.1 Safety Design Basis

The solid waste management system performs no function related to the safe shutdown of the plant. The system's failure does not adversely affect any safety-related system or component; therefore, the system has no nuclear safety design basis.

There are no safety related systems located near heavy lifts associated with the solid waste management system. Therefore, a heavy loads analysis is not required.

11.4.1.2 Power Generation Design Basis

The solid waste management system provides temporary onsite storage for wastes prior to processing and for the packaged wastes. The system has a 60-year design objective and is designed for maximum reliability, minimum maintenance, and minimum radiation exposure to operating and maintenance personnel. The system has sufficient temporary waste accumulation capacity based on maximum waste generation rates so that maintenance, repair, or replacement of the solid waste management system equipment does not impact power generation.

11.4.1.3 Functional Design Basis

The solid waste management system is designed to meet the following objectives:

- Provide for the transfer and retention of spent radioactive ion exchange resins and deep bed filtration media from the various ion exchangers and filters in the liquid waste processing, chemical and volume control, and spent fuel cooling systems
- Provide the means to mix, sample, and transfer spent resins and filtration media to high integrity containers or liners for dewatering or solidification as required
- Provide the means to change out, transport, sample, and accumulate filter cartridges from liquid systems in a manner that minimizes radiation exposure of personnel and spread of contamination

- Provide the means to accumulate spent filters from the plant heating, ventilation, and air-conditioning systems
- Provide the means to segregate solid wastes (trash) by radioactivity level and to temporarily store the wastes
- Provide the means to accumulate radioactive hazardous (mixed) wastes
- Provide the means to segregate clean wastes originating in the radiologically controlled area (RCA)
- Provide the means to store packaged wastes for at least 6 months in the event of delay or disruption of offsite shipping
- Provide the space and support services required for mobile processing systems that will reduce the volume of and package radioactive solid wastes for offsite shipment and disposal according to applicable regulations, including Department of Transportation regulation 49 CFR 173 ([Reference 1](#)) and NRC regulation 10 CFR 71 ([Reference 2](#))
- Provide the means to return liquid radwaste to the liquid radwaste system (WLS) for subsequent processing and monitored discharge

The solid waste management system is designed according to NRC Regulatory Guide 1.143 to meet the requirements of General Design Criterion (GDC) 60 as discussed in [Sections 1.9](#) and [3.1](#). The seismic design classifications of the radwaste building and system components are provided in [Section 3.2](#).

Provisions are made in the auxiliary and radwaste buildings to use mobile radwaste processing systems for processing and packaging each waste stream including concentration and solidification of chemical wastes from the liquid waste management system, spent resin dewatering, spent filter cartridge encapsulation and dry active waste sorting and compaction.

The radioactivities of influents to the solid waste management system are based on estimated radionuclide concentrations and volumes. These estimates are based on operating plant experience, adjusted for the size and design differences of AP1000. The influent source terms are consistent with [Section 11.1](#).

The solid waste management system airborne process effluents are released through the monitored plant vent as described as part of the 10 CFR 50 ([Reference 3](#)), Appendix I, analysis presented in [Subsection 11.3.3](#).

The solid waste management system collects and stores radioactive wastes within shielding to maintain radiation exposure to plant operation and maintenance personnel as low as is reasonably achievable (ALARA) according to General Design Criteria 60 as discussed in [Section 3.1](#) and Regulatory Guide 8.8. Personnel exposures will be maintained well below the limits of 10 CFR 20 ([Reference 4](#)). Design features incorporated to maintain exposures ALARA include remote and semi-remote operations, automatic resin transport line flushing, and shielding of components, piping and containers holding radioactive materials. Access to the solid waste storage areas is controlled, to minimize inadvertent personnel exposure, by suitable barriers such as heavy storage cask covers and locked or key-card-operated doors or gates (see [Section 12.1](#)).

The solid waste management system conforms to the design criteria of NRC Branch Technical Position ETSB 11-3. Suitable fire protection systems are provided as described in [Subsection 9.5.1](#).

Waste disposal containers are to be selected from available designs that meet the requirements of the DOT and NRC. The solid waste management system does not require source-specific waste containers. Waste containers must meet the regulatory requirements for radioactive waste transportation in 49 CFR 173 and for radioactive waste disposal in 10 CFR 61 (Reference 5) as well as specific disposal facility requirements.

11.4.1.4 Compliance with 10 CFR 20.1406

In accordance with the requirements of 10 CFR 20.1406 (Reference 11), the solid radwaste system is designed to minimize, to the extent practicable, contamination of the facility and the environment, facilitate decommissioning, and minimize, to the extent practicable, the generation of radioactive waste. This is done through appropriate selection of design technology for the system, plus incorporating the ability to update the system to use the best available technology throughout the life of the plant.

11.4.2 System Description

11.4.2.1 General Description

The solid waste management system includes the spent resin system. The flows of wastes through the solid waste management system are shown on Figure 11.4-1. The radioactivity of influents to the system are dependent on reactor coolant activities and the decontamination factors of the processes in the chemical and volume control system, spent fuel cooling system, and the liquid waste processing system.

The parameters used to calculate the estimated activity of the influents to the solid waste management system are listed in Table 11.4-1. The estimated expected isotopic curie content of the primary spent resin and filter cartridge wastes to be processed on an annual basis is listed on Table 11.4-2. Table 11.4-3 provides the same information for the estimated maximum annual activities. The AP1000 has sufficient radwaste storage capacity to accommodate the maximum generation rate.

The radioactivity of the dry active waste is expected to normally range from 0.1 curies per year to 8 curies per year with a maximum of about 16 curies per year. This waste includes spent HVAC filters, compressible trash, non-compressible components, mixed wastes and solidified chemical wastes. These activities are produced by relatively long lived radionuclides (such as Cr-51, Fe-55, Co-58, Co-60, Nb-95, Cs-134 and Cs-137), and therefore, radioactivity decay during processing and storage is minimal. These activities thus apply to the waste as generated and to the waste as shipped.

The estimated expected and maximum annual quantities of waste influents by source and form are listed in Table 11.4-1 with disposal volumes. The annual radwaste influent rates are derived by multiplying the average influent rate (e.g. volume per month, volume per refueling cycle) by one year of time. The annual disposal rate is determined by applying the radwaste packaging efficiency to the annual influent rate. The influent volumes are conservatively based on an 18-month refueling cycle. Annual quantities based on a 24-month refueling cycle are less than those for an 18-month cycle. The estimated expected isotopic curie content of the primary spent resin and filter cartridge wastes to be shipped offsite are presented in Table 11.4-4 based on 90 days of decay before shipment. The same information is presented in Table 11.4-5 for the estimated maximum activities based on 30 days of decay before shipment.

Section 11.1 provides the bases for determination of liquid source terms used to calculate several of the solid waste management system influent source terms. The influent data presented in Tables 11.4-2 and 11.4-3 are conservatively based on Section 11.1 design basis (Technical Specification) values.

All radwaste which is packaged and stored by AP1000 will be shipped for disposal. The AP1000 has no provisions for permanent storage of radwaste. Radwaste is stored ready for shipment. Shipped volumes of radwaste for disposal are estimated in [Table 11.4-1](#) from the estimated expected or maximum influent volumes by making adjustments for volume reduction processing by mobile systems and the expected container filling efficiencies. For drum compaction, the overall volume reduction factor, including packaging efficiency, is 3.6. For box compaction, the overall volume reduction factor is 5.4. These adjustments result in a packaged internal waste volume for each waste source, and the number of containers required to hold this volume is based on the container's internal volume. The disposal volume is based on the number of containers and the external (disposal) volume of the containers.

The expected disposal volumes of wet and dry wastes are approximately 547 and 1417 cubic feet per year, respectively as shown in [Table 11.4-1](#). The wet wastes shipping volumes include 510 cubic feet per year of spent ion exchange resins and deep bed filter activated carbon, 20 cubic feet of volume reduced liquid chemical wastes and 17 cubic feet of mixed liquid wastes. The spent resins and activated carbon are initially stored in the spent resin storage tanks located in the rail car bay of the auxiliary building. When a sufficient quantity has accumulated, the resin is sluiced into two 158 cubic feet high-integrity containers in anticipation of transport for offsite disposal. Liquid chemical wastes are reduced in volume and packaged into three 55-gallon drums per year (about 20 cubic feet) and are stored in the packaged waste storage room of the radwaste building. The mixed liquid wastes fill less than three drums per year (about 17 cubic feet per year) and are stored on containment pallets in the waste accumulation room of the radwaste building until shipped offsite for processing.

The two spent resin storage tanks (250 cubic feet usable, each) and one high integrity container in the spent resin waste container fill station at the west end of the rail car bay of the auxiliary building provide more than a year of spent resin storage at the expected rate, and several months of storage at the maximum generation rate. The expected radwaste generation rate is based upon the following:

- All ion exchange resin beds are disposed and replaced every refueling cycle.
- The WGS activated carbon guard bed is replaced every refueling cycle.
- The WGS delay beds are replaced every ten years.
- All wet filters are replaced every refueling cycle.
- Rates of compactible and non-compactible radwaste, chemical waste, and mixed wastes are estimated using historical operating plant data.

The maximum radwaste generation rate is based upon the following:

- The ion exchange resin beds are disposed based upon operation with 0.25% fuel defects.
- The WGS activated carbon guard bed is replaced twice every refueling cycle.
- The WGS delay beds are replaced every five years.
- All wet filters are replaced based upon operation with 0.25% fuel defects.
- The expected rates of compactible and non-compactible radwaste, chemical waste, and mixed wastes are increased by about 50%.

- Primary to secondary system leakage contaminates the condensate polishing system and blowdown system resins and membranes which are replaced.

The dry solid radwaste includes 1383 cubic feet per year of compactible and non-compactible waste packed into about 14 boxes (90 cubic feet each) and ten drums per year. Drums are used for higher activity compactible and non-compactible wastes. Compactible waste includes HVAC exhaust filter, ground sheets, boot covers, hair nets, etc. Non-compactible waste includes about 60 cubic feet per year of dry activated carbon and other solids such as broken tools and wood. Solid mixed wastes will occupy 7.5 cubic feet per year (one drum). The low activity spent filter cartridges may be compacted to fill about 0.40 drums per year (3 ft³/year) and are stored in the packaged waste storage room. Compaction is performed by mobile equipment or is performed offsite. High activity filter cartridges fill three drums per year (22.5 cubic feet per year) and are stored in portable processing or storage casks in the rail car of the auxiliary building.

The total volume of radwaste to be stored in the radwaste building packaged waste storage room is 1417 cubic feet per year at the expected rate and 2544 cubic feet per year at the maximum rate. The compactible and non-compactible dry wastes, packaged in drums or steel boxes, are stored with the mixed liquid and mixed solid, volume reduced liquid chemical wastes, and the lower activity filter cartridges. The quantities of liquid radwaste stored in the packaged waste storage room of the radwaste building consist of 20 cubic feet of chemical waste and 17 cubic feet of mixed liquid waste. The useful storage volume in the packaged waste storage room is approximately 3900 cubic feet (10 feet deep, 30 feet long, and 13 feet high), which accommodates more than one full offsite waste shipment using a tractor-trailer truck. The packaged waste storage room provides storage for more than two years at the expected rate of generation and more than a year at the maximum rate of generation. One four-drum containment pallet provides more than 8 months of storage capacity for the liquid mixed wastes and the volume reduced liquid chemical wastes at the expected rate of generation and more than 4 months at the maximum rate.

A conservative estimate of solid wet waste includes blowdown material based on continuous operation of the steam generator blowdown purification system, with leakage from the primary to secondary system. The volume of radioactively contaminated material from this source is estimated to be 540 cubic feet per year. Provisions for processing and disposal of radioactive steam generator blowdown resins and membranes are described in [Subsection 10.4.8](#). Note that, although included here for conservatism, this volume of contaminated resin will be removed from the plant within the contaminated electrodeionization unit and not stored as wet waste.

The condensate polishing system includes mixed bed ion exchanger vessels for purification of the condensate as described in [Subsection 10.4.6](#). Should the resins become radioactive, the resins are transferred from the condensate polishing vessel directly to a temporary processing unit or to the temporary processing unit via the spent resin tank. The processing unit, located outside of the turbine building, dewateres and processes the resins as required for offsite disposal. Radioactive condensate polishing resin will have very low activity. It will be disposed in containers as permitted by DOT regulations. After packaging, the resins may be stored in the radwaste building. Based on a typical condensate polishing system operation of 30 days per refueling cycle with leakage from the primary system to the secondary system, the volume of radioactively contaminated resin is estimated to be 206 cubic feet per year (one 309 cubic foot bed per refueling cycle). Normal disposal of nonradioactive condensate polishing system resins is described in [Subsection 10.4.6](#).

The parameters used to calculate the activities of the steam generator blowdown solid waste and condensate polishing resins are given in [Table 11.4-1](#). Based on the above volumes, the disposal volume is estimated to be 939 cubic feet per year. The expected and maximum activities of the resins as generated are given in [Tables 11.4-6](#) and [11.4-7](#), respectively. The expected and maximum activities of resins as shipped, based on 90 days decay prior to shipment, are given in [Tables 11.4-8](#) and [11.4-9](#), respectively.

11.4.2.2 Component Description

The seismic design classification and safety classification for the solid waste management system components are listed in [Section 3.2](#). The components listed are located in the seismic Category I Nuclear Island. [Table 11.4-10](#) lists the solid waste management system equipment design parameters. The following subsections provide a functional description of the major system components.

11.4.2.2.1 Spent Resin Tanks

The spent resin tanks provide holdup capacity for spent resin and filter bed media decay before processing. High- and low-activity resins may be mixed to limit the radioactivity concentration in the waste containers to 10 Ci/ft³ in accordance with the USNRC Technical Position on Waste Form ([Reference 6](#)).

Resin mixing capability is provided by mixing eductors in each tank, and resin dewatering, air sparging and complete draining capabilities are also provided. The ultrasonic level sensors and dewatering screens are arranged for remote removal. The vent and overflow connections have screens to prevent the inadvertent discharge of spent resin, and they are routed to the radioactive waste drain system (WRS).

11.4.2.2.2 Resin Mixing Pump

The resin mixing pump provides the motive force to fluidize and mix the resins in the spent resin tanks, to transfer water between spent resin tanks, to discharge excess water from the spent resin tanks to the liquid waste processing system, and to flush the resin transfer lines.

11.4.2.2.3 Resin Fines Filter

The resin fines filter minimizes the spread of high-activity resin fines and dislodged crud particles by filtering the water used for line flushing or discharged from the spent resin tanks to the liquid waste processing system.

11.4.2.2.4 Resin Transfer Pump

The resin transfer pump provides the motive force for recirculation of spent resins via either one of the spent resin tanks for mixing and sampling, for transferring spent resin between tanks, and for blending high- and low-activity resins to meet the specific activity limit for disposal. The resin transfer pump is also used to transfer spent resins to a waste container in the fill station or in its shipping cask located in the auxiliary building rail car bay.

11.4.2.2.5 Resin Sampling Device

The resin sampling device collects a representative sample of the spent resin either during spent resin recirculation or during spent resin waste container filling operations. A portable shielded cask is provided for sample jar transfer.

11.4.2.2.6 Filter Transfer Cask

The filter transfer cask permits remote changing of filter cartridges, dripless transport to the storage area in the auxiliary building, transfer of the filter cartridges into and out of the filter storage, and loading of the filter cartridges into disposal containers.

11.4.2.3 System Operation

11.4.2.3.1 Spent Resin Handling Operations

Demineralized water is used to transfer spent resins from the various ion exchangers to the spent resin tanks. A demineralized water transfer pump provides the pressurized water flow to transfer the spent resins as described in [Subsection 9.2.4](#). Before the transfer operation, it is verified that the selected spent resin tank is aligned as a receiver and has the capacity to accept the bed. It is also verified that the resin mixing pump is aligned to discharge excess transfer water through the resin fines filter to the liquid waste processing system.

During the transfer operation the tank level is monitored and the resin mixing pump is operated, if required, to limit tank water level. The operator stops the transfer when the CCTV camera viewing the sight flow glass indicates on a control panel monitor that the sluice water is clear and the transfer line is, therefore, flushed of resins.

After the bed transfer, the tank solids level can be checked by operating the resin mixing pump to lower the water level below the solids level. The solids level can be determined by the ultrasonic surface detector.

Between bed transfer operations the water level in the spent resin tanks is maintained above the solids level. Demineralized water is supplied for water level adjustment as well as a backup water source for flushing resin handling lines after resin recirculation and waste disposal container filling operations.

The solids bed can be agitated and mixed at any time by using compressed air or by operating the resin mixing pump in the resin mixing mode. In the resin mixing mode, water is drawn from the spent resin tank via resin retention screens. The water is returned via tank mixing eductors that generate a resin slurry recirculation within the tank equivalent to about four times the flow rate generated by the resin mixing pump. The solids bed is locally fluidized during this operation.

The resin mixing mode is established to fluidize and mix the solids bed in the spent resin tank before waste disposal container filling. The resin transfer pump is then started in the recirculation mode. A resin slurry is drawn from the spent resin tank and returned to the same tank. A representative resin sample may be obtained during recirculation or container filling modes by operating the sampling device.

The portable system's container fill valve is opened to initiate the filling operation. The resin dewatering pump of the portable dewatering system is started to dewater the resin as it accumulates in the container. The resin dewatering pump discharges the water to the recirculation line. The water flows back to the spent resin tank, thereby preserving the water inventory in the system and retaining any resin fines or dislodged crud within the system.

The resin mixing pump can be stopped at any time during the filling operation. When the solids level nears the top of the container, as detected by level sensors and observed by a television camera, the fill valve is closed and cycled to top off the container. Excessive water or solids level automatically closes the fill valve.

When the filling operation is complete, the line flushing sequence controller is manually initiated to automatically operate the pumps and valves to flush the resin transfer lines back to the spent resin tank. The container fill valve is opened for a short time period to flush the remaining resin to the waste container. The resin mixing pump supplies filtered flush water from the spent resin tank. The portable dewatering system's dewatering pump is operated periodically until no further dewatering flow is detected by the pump discharge pressure indicator and/or audible indications from the pump.

11.4.2.3.2 Spent Filter Processing Operations

A filter transfer cask is used to change the higher-activity filters of the chemical and volume control system and spent fuel cooling system. The filter vessel is drained, and the filter cover is opened remotely. The shield plug of the port over the filter is removed and the transfer cask, without its bottom shield cover, is lifted and positioned on the port directly over the cartridge in the filter vessel.

A grapple inside the transfer cask is remotely lowered and connected to the filter cartridge. The cartridge is lifted into the transfer cask, and the cask is transferred over plastic sheeting to the bottom shield cover. The dose rate of the cartridge is measured with a long probe, and the cask is lowered onto and connected to the bottom shield cover. The transfer cask is then moved to the auxiliary building rail car bay.

If recent applicable sample analysis results are available, the filter cartridge can be loaded directly into a disposal container as described in the following paragraph. If analysis is required, a sample of the filter media is obtained through a port in the transfer cask. The filter cartridge is placed in one of nine high-activity filter storage tubes until sample analysis results are available. The transfer cask bottom cover is disconnected, the transfer cask is lifted by the crane and transferred to a position over one of the temporary storage tubes, and the spent filter cartridge is lowered into the tube. After moving the transfer cask away, the crane is used to install a shield plug onto the storage tube. Any water draining from the filter during storage collects in the storage tube which may be drained to a floor drain for subsequent transfer to the liquid radwaste system.

When sample analysis is complete and packaging requirements are established, the transfer cask is used to retrieve the spent cartridges from storage and deposit them into a waste container via a port in the top of a portable processing and storage cask. Plastic coverings are removed and the container is capped, smear-surveyed, and decontaminated as required, using reach rod tools through a cask port. The dose rate survey is also made through a cask port. Transfer of the filled waste container to the shipping cask, including cask cover handling, is then performed using the rail car bay crane under remote control.

Filters with dose rates less than 15 R/hr on contact may be changed from outside of filter vessel shielding by using reach rod tools. The filter vessel is drained, and the cover is removed. Then the spent filter cartridge is grappled and lifted out and into a filter transfer cask.

At the radwaste building, low and moderate activity filter cartridges are deposited into disposal or storage drums. The drums are stored within portable shield casks in the shielded accumulation room, which is serviced by the mobile systems facility crane. Depending on dose rates and analysis results, stabilization may or may not be required. Cartridges not requiring stabilization are loaded into standard, 55 gallon shipping drums with absorbent and may be compacted using a mobile system. When stabilization is required, the cartridges may be loaded into either high integrity containers or standard drums. If standard drums are used, mobile equipment is used to encapsulate the contents of the drums.

The drum covers are manually installed, and the drums are smear surveyed, decontaminated by wiping, if required, weighed, stacked on pallets, and placed in the packaged waste storage room.

When a truck-load quantity of waste containers accumulates, shipment to a low-level waste disposal facility is initiated by loading pallets of drums and other low-level waste containers into a closed van using the scissor lift or onto a flat-bed trailer using the crane. If the activity level is too high for unshielded shipment, the drums are loaded onto a cask pallet and into a shielded shipping cask using the mobile systems facility crane.

Radioactive filters from ventilation exhaust filtration units are bagged and transported to the radwaste building, where they are temporarily stored. The filters are compacted along with other dry active wastes by a mobile system as described in the following subsection.

11.4.2.3.3 Dry Waste Processing Operations

Dry wastes are segregated by measuring the contact dose rate of the wastes to determine the appropriate processing method. The contact dose rates for initial waste segregation are as follows:

Low activity	<5 mR/hr
Moderate activity	5 mR/hr to 100 mR/hr
High activity	>100 mR/hr

These activity levels may be adjusted by the operator to minimize exposures while maximizing processing efficiency.

Wastes from surface contamination areas in the radiologically controlled area are placed in bags or containers and tagged at the point of origin with information on radiation levels, waste type, and destination. The bags or containers are transported to the radwaste building, where they are placed into low-, moderate-, or high-activity storage, segregated by portable shielding as appropriate.

The high-activity wastes (greater than 100 mR/hr) are normally expected to be compacted in drums using a mobile compactor system in the same manner as lower-activity filter cartridges.

Moderate-activity wastes (5 mR/hr to 100 mR/hr) are expected to be sorted in a mobile system to remove reusable items such as protective clothing articles and tools, hazardous wastes, and larger noncompressible items. The remaining wastes are normally compacted by mobile equipment. The packaged wastes may be loaded directly onto a truck for shipment or may be stored in the packaged waste storage room until a truck load quantity accumulates.

Low-activity, dry active waste (less than 5 mR/hr) generally contains a large amount of nonradioactive material. It is expected that these wastes normally will be processed through a mobile radiation monitoring and sorting system to remove non-radioactive items for reuse or local disposal. A radiation survey allows identification and removal of potentially clean items for the clean waste verification. The remaining radioactive wastes are normally compacted or packaged for disposal as appropriate.

Materials that enter the radiologically controlled area are verified as nonradioactive before being released for reuse or disposal. Tools and equipment belonging to personnel and contractors are surveyed at the radiologically controlled area exit in the annex building. If these items cannot be released or decontaminated, they become plant inventory or dry active waste and are handled as described previously.

Other wastes generated in the radiologically controlled area but outside of surface contamination areas are collected in bags or containers and are delivered to the temporary storage location in the radwaste building. These wastes normally are processed through a mobile radiation monitoring system to verify that they are nonradioactive and suitable for disposal in a local waste landfill.

11.4.2.3.4 Mixed Waste Processing Operations

Mixed wastes from the radiologically controlled area are collected in suitable containers and brought to the radwaste building, where separate containment pallets and accumulation drums are provided

for solid and liquid mixed wastes. Mixed wastes are normally sent to an offsite facility having mixed-waste processing and disposal capabilities.

11.4.2.4 Waste Processing and Disposal Alternatives

11.4.2.4.1 Portable and Mobile Radwaste Systems Capabilities

Portable or mobile processing and packaging systems can be located in the auxiliary building rail car bay or the radwaste building mobile systems facility. Chemical wastes are normally processed in the radwaste building by a mobile concentration and/or solidification system when a batch accumulates in the chemical waste tank. Mobile systems are also used to encapsulate high-activity filters, to sort, decontaminate and compact dry active wastes, and to verify nonradioactive wastes.

The spent resin system includes connections in the fill station and rail car bay to allow spent resins to be delivered to a disposal container in either location for dewatering using portable equipment.

Branch Technical Position ETSB 11-3 provides guidance for portable solid waste systems in Section IV. Compliance with the four guidance items is achieved as follows:

- IV.1 The spent resin tanks are the only tanks that contain a significant volume of wet wastes, and these tanks are permanently installed. Concentrates that may be produced by mobile evaporation systems will be produced and stored by the mobile systems only in small batches prior to being solidified by the mobile systems. As described in [Subsection 1.2.7](#), the radwaste building is designed to retain spillage from mobile or portable systems.
- IV.2 Permanently installed piping for transport of radioactive wastes to mobile or portable systems is routed close to the mobile or portable systems thereby minimizing the use of flexible interfacing hose. The hydrostatic test requirements of Regulatory Guide 1.143 will be applied to the flexible interfacing hose.
- IV.3 Portable or mobile systems will be located in either the rail car bay of the auxiliary building or in the mobile systems facility in the radwaste building. The spent resin waste container fill station or the shipping cask in the auxiliary building collects spillage of spent resin during waste container filling operations. The radwaste and auxiliary buildings contain and drain spillage to the liquid radwaste system via the radioactive waste drain system as described in [Subsection 1.2.7](#) and [Section 11.2](#). Portable or mobile systems will, when required, have their own HEPA filtered exhaust ventilation system. HEPA filtered exhaust is required when airborne radioactivity would exceed 10 CFR 20 derived air concentration limits for radiation workers. The mobile systems facility has connections on the exhaust ventilation ducts for connecting exhaust duct from mobile or portable processing systems to the building's exhaust ventilation system.
- IV.4 Although the seismic criteria of Regulatory Guide 1.143 are not applicable to structures housing mobile or portable solid radwaste systems, the portable equipment used for spent resin container filling and dewatering and high-activity filter cartridge packaging will be housed within the Seismic Category I auxiliary building. The radwaste building, which provides shelter for mobile or portable radwaste systems, is non-seismic in accordance with Branch Technical Position ETSB 11-3.

11.4.2.4.2 Central Radwaste Processing Facility

As an alternative to the mobile or portable processes for lower-activity wastes, the wastes may be sent to a licensed central radwaste processing facility for processing and disposal. This option requires minimal onsite processing to remove radioactive materials from the waste streams. The

wastes are loaded into a cargo container. The mobile systems facility includes a designated laydown area, and the mobile systems facility crane may be used to handle a cargo container.

11.4.2.4.3 Alternatives for B and C Wastes

It is expected that Class B and C wastes will constitute approximately 5 percent by volume of the low level radioactive waste (LLRW) that will be generated by the plant with the balance being Class A waste. The volume of wet Class B and C waste is approximately 100 percent of the total Class B and C waste. As of July 1, 2008, the LLRW disposal facility in Barnwell, South Carolina is no longer accepting Class B and C waste from sources in states that are outside of the Atlantic Compact. However, the disposal facility in Clive, Utah is still accepting Class A waste from out of state. Should there be no disposal facilities that will accept the Class B and C wastes after the plant begins operation, there are several options available for storage of such waste:

- As provided in referenced **Subsection 11.4.2**, the Auxiliary Building is designed to have more than a year of spent resin storage capacity at the expected rate and the spent resin tanks may be mixed to limit the radioactivity concentrations thereby limiting the volume of Class B and C wet waste requiring storage.
- Vendor services are available to process Class A, B, and C waste and transfer for storage of that material until a disposal site is available. Currently, Waste Control Specialists (WCS) of Texas is available to store Class A, B, and C material pending the availability of a licensed disposal site.
- If additional storage capacity were eventually needed, the plant could construct or expand storage facilities onsite or gain access to a storage facility at another licensed nuclear plant.

11.4.2.5 Facilities

11.4.2.5.1 Auxiliary Building

Resin and filtration media transfer lines from the various ion exchangers are routed to the spent resin tanks on elevation 100' - 0" in the southwest corner of the auxiliary building. The spent resin system pumps, valves, and piping are located in shielded rooms near the spent resin tanks.

Liquid radwaste system transfer lines to and from the radwaste building are routed to the south wall of the auxiliary building where they penetrate and enter into a shielded pipe pit in the base mat of the radwaste building.

Accessways in the auxiliary building are used to move the filter transfer casks. This includes filter transfer cask handling from the containment, where the chemical and volume control filters are located, to the auxiliary building rail car bay, where the filter cartridges are stored and subsequently packaged using mobile equipment. These accessways are also used to move dry active waste from various collection locations to the radwaste building. Enclosed access is provided between the auxiliary building and the radwaste building on elevation 100'-0" (grade level).

11.4.2.5.2 Radwaste Building

The radwaste building, described in **Section 1.2**, houses the mobile systems facility. It also includes the waste accumulation room and the packaged waste storage room. These rooms are serviced by the mobile systems facility crane.

In the mobile systems facility, three truck bays provide for mobile or portable processing systems and for waste disposal container shipping and receiving. A shielded pipe trench to each of the truck bays is used to route liquid radwaste supply and return lines from the connections in the shielded pipe pit

at the auxiliary building wall. Separate areas are reserved for empty (new) waste disposal container storage, container laydown, and forklift charging. An area is available near the door to the annex building for protective clothing dropoff and frisking.

The waste accumulation room (pre-processing) is divided as needed, using partitions and portable shielding to adjust the storage areas for different waste categories as needed to complement the radioactivity levels and volumes of generated wastes. The accumulation room has lockable doors to minimize unauthorized entry and inadvertent exposure.

The packaged waste storage room may be separated into high- and low-activity areas, using portable shielding to minimize exposure while providing operational flexibility. A lockable door is provided to minimize unauthorized entry and radiation exposure.

The heating and ventilating system for the radwaste building is described in [Subsection 9.4.8](#).

11.4.3 System Safety Evaluation

The solid waste management system has no safety-related function and therefore requires no nuclear safety evaluation.

11.4.4 Tests and Inspections

Preoperational tests are conducted as described in [Subsection 14.2.9](#). Tests are performed to demonstrate the capability to transfer ion exchange resins and deep bed filtration media from the ion exchangers and filters to the spent resin tanks or directly to a waste disposal container. Preoperational tests of the solid waste management system components are performed to prepare the system for operation.

After plant operations begin, the operability and functional performance of the solid waste management system is periodically evaluated according to Regulatory Guide 1.143 by monitoring for abnormal or deteriorating performance during routine operations. Instruments and setpoints are also calibrated on a scheduled basis. The preventive maintenance program includes periodic inspection and maintenance of active components.

11.4.5 Quality Assurance

The quality assurance program for design, installation, procurement, and fabrication issues of the solid waste management system is in accordance with the overall quality assurance program described in [Chapter 17](#).

Since the impact of radwaste systems on safety is limited, the extent of control required by Appendix B to 10 CFR Part 50 is similarly limited. Thus, a supplemental quality assurance program applicable to design, construction, installation and testing provisions of the solid radwaste system is established by procedures that complies with the guidance presented in Regulatory Guide 1.143.

11.4.6 Combined License Information for Solid Waste Management System Process Control Program

A Process Control Program (PCP) is developed and implemented in accordance with the recommendations and guidance of NEI 07-10A ([Reference 201](#)). The PCP describes the administrative and operational controls used for the solidification of liquid or wet solid waste and the dewatering of wet solid waste. Its purpose is to provide the necessary controls such that the final disposal waste product meets applicable federal regulations (10 CFR Parts 20, 50, 61, 71, and 49

CFR Part 173), state regulations, and disposal site waste form requirements for burial at a low level waste (LLW) disposal site that is licensed in accordance with 10 CFR Part 61.

Waste processing (solidification or dewatering) equipment and services may be provided by the plant or by third-party vendors. Each process used meets the applicable requirements of the PCP.

No additional onsite radwaste storage is required beyond that described in the DCD.

Table 13.4-201 provides milestones for PCP implementation.

11.4.6.1 Procedures

Operating procedures specify the processes to be followed to ship waste that complies with the waste acceptance criteria (WAC) of the disposal site, 10 CFR 61.55 and 61.56, and the requirements of third party waste processors.

Each waste stream process is controlled by procedures that specify the process for packaging, shipment, material properties, destination (for disposal or further processing), testing to verify compliance, the process to address non-conforming materials, and required documentation.

Where materials are to be disposed of as non-radioactive waste (as described in [Subsection 11.4.2.3.3](#)), final measurements of each package are performed to verify there has not been an accumulation of licensed material resulting from a buildup of multiple, non-detectable quantities. These measurements are obtained using sensitive scintillation detectors, or instruments of equal sensitivity, in a low-background area.

Procedures document maintenance activities, spill abatement, upset condition recovery, and training.

Procedures document the periodic review and revision, as necessary, of the PCP based on changes to the disposal site, WAC regulations, and third party PCPs.

11.4.6.2 Third Party Vendors

Third party equipment suppliers and/or waste processors are required to supply approved PCPs. Third party vendor PCPs describe compliance with Regulatory Guide 1.143 ([Reference 7](#)), Generic Letter 80-09 ([Reference 8](#)), and Generic Letter 81-39 ([Reference 9](#)). Third party vendor PCPs are referenced appropriately in the plant PCP before commencement of waste processing.

11.4.6.3 Long Term On-Site Storage Facility

Storage space for six-month's volume of packaged waste is provided in the radwaste building. Radioactive waste generated by VEGP Units 3 and 4 will normally be shipped to a licensed disposal or off-site storage facility. However, should disposal facilities or off-site storage facilities not be available, storage capacity will be expanded as described below to provide additional on-site storage for VEGP Units 3 and 4.

Additional on-site low-level radioactive waste (LLRW) storage capabilities are available if Class B and C waste cannot be disposed at a licensed disposal facility. An outside storage pad will be utilized to provide this capability. The VEGP Units 3 and 4 LLRW storage facility would be located outside the Protected Area (PA) in the Owner Controlled Area (OCA). The storage facility would be enclosed by an eight-foot high fence with locked gates and would be provided with area lighting. The storage of LLRW would be in high integrity containers (HICs) or other suitable containers that will not decay over time, which would be stored within shielded containers. The design of the storage facility will comply with the guidance of documents as identified in this section which is consistent with NUREG-

0800, Appendix 11.4A. The design storage capacity is based on the expected generation in [Table 11.4-1](#), industry experience that indicates approximately 100% of the Class B and C waste is expected to be in the form of wet waste, and volume minimization/reduction programs. The site waste management plan will include radioactive wet waste reduction initiatives for waste Class B and C.

The storage facility will be sited such that it could be sized to accommodate storage of Class B and C waste over the operating life of the plant and designed to accommodate future expansion as needed. Capacity would be added in phases based on the expected availability of off-site treatment and storage, and disposal facilities.

11.4.6.3.1 Outside Storage Pad Design Considerations

The following design considerations would be applied to the on-site LLRW storage facility: ([References 202, 203, and 10](#)):

- The location of the storage pad would meet the dose rate criteria of 40 CFR 190 and 10 CFR 20.1302 for both the site boundary and unrestricted area. The onsite storage will be located such that any additional dose contributes less than 1 mrem per year to the 40 CFR Part 190 limits. Onsite dose limits will be controlled per 10 CFR 20, including the ALARA principle of 10 CFR 20.1101.
- The outside storage pad would be an engineered feature designed to minimize settling and would be constructed of reinforced concrete or engineered gravel.
- The storage pad location would avoid natural or engineered surface drainage and be located at an elevation with regard to the site's design bases flood level.
- The storage pad would have a fence or other suitable security measures consistent with its location on the site.
- If the storage pad is used to store an aggregated category 1 or category 2 quantity of radioactive material (radioactive waste), then the 10 CFR Part 37 Physical Protection Program would be applied.
- The waste containers (typically high integrity containers) would be stored inside of a shielded container, typically consisting of reinforced concrete containers that provide radiation shielding and weather protection.
- The configuration of the storage shields would be arranged to be accessible from the perimeter road or from a center aisle using a mobile crane (if used).
- Personnel passages would be provided between rows of storage shields for access to the container for inspection.
- Adequate electrical power and lighting would be provided at the storage facility to allow power for tools, analytical equipment, sample pumps, radiation instruments, boroscope lights, etc.
- Fire protection, fire hydrants or fire extinguishers, for vehicle fires should be provided.

11.4.6.3.2 Outside Storage Pad Operating Considerations

The following operating considerations for on-site storage pad operations are based on NRC and Industry guidance ([References 202, 203, and 10](#)) and would be included in operating procedures:

- Identification of the arrangement of storage shields, waste handling, storage methods, safety analysis limitations, accident conditions, and off site dose calculations.
- The use of hold-down devices to secure the waste container during severe environmental events, such as strong wind would be provided for, unless the waste container and storage shields can be demonstrated to remain in place without restraints during such events.
- The waste container selected for use is compatible with the waste form stored to ensure waste container integrity.
- Shielding requirements would be determined before the waste container is loaded into a storage shield to eliminate the radiation exposure associated with adding additional shielding.
- If additional shield walls around the perimeter of the storage pad are required, the shield walls would be easily installed and capable of being moved.
- Periodic inspection and testing requirements for outside storage pad operation would include the following:
 - Dose rate and contamination surveys in accordance with health physics procedures.
 - Sampling of storage shields for water and storage shields containing dewatered resin for explosive gas build-up.
 - Visual inspection of selected waste containers in storage to detect unexpected changes / container integrity. (Remote inspection methods and the use of high integrity containers will allow reduced scope for ALARA practices.)
 - Defoliation and general condition of the onsite storage pad.
- Total radioactive material inventory limits would be established to demonstrate compliance with the design limits for the storage area, dose limits for members of the public and safety features or measures provided by the storage module.
- The contents of records for inventory controls, monitoring and inspection and other relevant data are maintained and retrievable.
- Operational safety features for handling waste containers and storage shields would include the training required for personnel operating cranes, forklifts, tie downs and heavy equipment during any waste container/storage shield transfer activity.
- Criteria for the end of storage period that would include waste container inspection and additional reprocessing required prior to shipment offsite.

11.4.7 References

1. "Shippers-General Requirements for Shipments and Packagings," 49 CFR 173.
2. "Packaging and Transportation of Radioactive Material," 10 CFR 71.
3. "Domestic Licensing of Production and Utilization Facilities," 10 CFR 50.
4. "Standards for Protection Against Radiation," 10 CFR 20.

5. "Licensing Requirements for Land Disposal of Radioactive Waste," 10 CFR 61.
6. "USNRC Technical Position on Waste Form," Rev. 1, January 1991.
7. Regulatory Guide 1.143, "Design Guidance for Radioactive Waste Management Systems, Structures, and Components Installed in Light-Water-Cooled Nuclear Power Plants."
8. USNRC Generic Letter GL-80-009, "Low Level Radioactive Waste Disposal," dated January 29, 1980.
9. USNRC Generic Letter GL-81-039, "NRC Volume Reduction Policy (Generic Letter No. 81-39)," dated November 30, 1981.
10. USNRC Generic Letter GL-81-038, "Storage of Low-Level Radioactive Wastes at Power Reactor Sites," dated November 10, 1981.
11. USNRC, "Minimization of Contamination," 10 CFR 20.1406.
201. [NEI 07-10A, "Generic FSAR Template Guidance for Process Control Program \(PCP\)," Revision 0, March 2009 \(ML091460627\).](#)
202. [Technical Report 1018644 "Guidelines for Operating an Interim On Site Low Level Radioactive Waste Storage Facility," Revision 1, EPRI, Palo Alto, CA, February 2009.](#)
203. [Regulatory Issue Summary 2008-32 "Interim Low Level Radioactive Waste Storage at Reactor Sites," December 2008.](#)

**Table 11.4-1
Estimated Solid Radwaste Volumes**

Source	Expected Generation (ft ³ /yr)	Expected Shipped Solid (ft ³ /yr)	Maximum Generation (ft ³ /yr)	Maximum Shipped Solid (ft ³ /yr)
Wet Wastes				
Primary Resins (includes spent resins and wet activated carbon)	400 ⁽²⁾	510	1700 ⁽⁴⁾	2160
Chemical	350	20	700	40
Mixed Liquid	15	17	30	34
Condensate Polishing Resin ⁽¹⁾	0	0	206 ⁽⁵⁾	259
Steam Generator Blowdown ⁽¹⁾⁽⁶⁾ Material (Resin and Membrane)	0	0	540 ⁽⁵⁾	680
Wet Waste Subtotals	765	547	3176	3173
Dry Wastes				
Compactible Dry Waste	4750	1010	7260	1550
Non-Compactible Solid Waste	234	373	567	910
Mixed Solid	5	7.5	10	15
Primary Filters (includes high activity and low activity cartridges)	5.2 ⁽³⁾	26	9.4 ⁽³⁾	69
Dry Waste Subtotals	4994	1417	7846	2544
TOTAL WET & DRY WASTES	5759	1964	11,020	5717

Notes:

1. Radioactive secondary resins and membranes result from primary to secondary systems leakage (e.g., SG tube leak).
2. Estimated activity basis is ANSI 18.1 source terms in reactor coolant.
3. Estimated activity basis is breakdown and transfer of 10% of resin from upstream ion exchangers.
4. Reactor coolant source terms corresponding to 0.25% fuel defects.
5. Estimated activity basis from Tables 11.1-5, 11.1-7 and 11.1-8 and a typical 30 day process run time, once per refueling cycle.
6. Estimated volume and activity used for conservatism. Resin and membrane will be removed with the electrodeionization units and not stored as wet waste. See Subsection 10.4.8.

Table 11.4-2 (Sheet 1 of 2)
Expected Annual Curie Content of Primary Influent

Isotope	Primary Resin Total Ci/yr	Primary Filter Total Ci/yr
Br-83	—	—
Br-84	1.98E-01	1.98E-02
Br-85	—	—
I-129	—	—
I-130	—	—
I-131	1.42E+02	1.42E+01
I-132	1.04E+01	1.04E+00
I-133	5.29E+01	5.29E+00
I-134	6.89E+00	6.89E-01
I-135	3.49E+01	3.49E+00
Rb-86	—	—
Rb-88	9.72E-01	9.72E-02
Rb-89	—	—
Cs-134	3.06E+02	3.06E+01
Cs-136	3.16E+00	3.16E-01
Cs-137	4.64E+02	4.64E+01
Cs-138	—	—
Ba-137m	4.44E+02	4.44E+01
Cr-51	3.21E+01	3.21E+00
Mn-54	1.04E+02	1.04E+01
Mn-56	—	—
Fe-55	1.04E+02	1.04E+01
Fe-59	5.00E+00	5.00E-01
Co-58	2.05E+02	2.05E+01
Co-60	9.59E+01	9.59E+00
Zn-65	3.02E+01	3.02E+00
Sr-89	2.67E+00	2.67E-01
Sr-90	1.13E+00	1.13E-01
Sr-91	1.72E-01	1.72E-02
Sr-92	—	—
Ba-140	6.29E+01	6.29E+00
Y-90	—	—
Y-91m	—	—
Y-91	3.74E-06	3.74E-07

Table 11.4-2 (Sheet 2 of 2)
Expected Annual Curie Content of Primary Influent

Isotope	Primary Resin Total Ci/yr	Primary Filter Total Ci/yr
Y-92	—	—
Y-93	—	—
La-140	—	—
Zr-95	2.80E-04	2.80E-05
Nb-95	—	—
Mo-99	—	—
Tc-99m	—	—
Ru-103	5.35E-03	5.35E-04
Ru-106	6.37E-02	6.37E-03
Rh-103m	—	—
Rh-106	—	—
Te-132	—	—
Te-125m	—	—
Te-127m	—	—
Te-127	—	—
Te-129m	1.36E-04	1.36E-05
Te-129	—	—
Te-131m	—	—
Total:	2.11E+03	2.11E+02

Note:

Values shown as "—" Ci/yr are those calculated to be lower than 1.0E-10 Ci/yr, and thus considered to have insignificant contributions to total.

Table 11.4-3 (Sheet 1 of 2)
Maximum Annual Curie Content of Primary Influent

Isotope	Primary Resin Total Ci/yr	Primary Filter Total Ci/yr
Br-83	7.03E+00	7.03E-01
Br-84	3.42E-01	3.42E-02
Br-85	3.74E-03	3.74E-04
I-129	3.44E-03	3.44E-04
I-130	9.00E+00	9.00E-01
I-131	5.45E+03	5.45E+02
I-132	1.97E+02	1.97E+01
I-133	1.66E+03	1.66E+02
I-134	7.31E+00	7.31E-01
I-135	3.81E+02	3.81E+01
Rb-86	2.97E+01	2.97E+00
Rb-88	2.52E+01	2.52E+00
Rb-89	9.83E-01	9.83E-02
Cs-134	9.57E+03	9.57E+02
Cs-136	1.72E+03	1.72E+02
Cs-137	9.14E+03	9.14E+02
Cs-138	1.06E+01	1.06E+00
Ba-137m	8.66E+03	8.66E+02
Cr-51	3.95E+01	3.95E+00
Mn-54	1.18E+02	1.18E+01
Mn-56	4.75E+01	4.75E+00
Fe-55	1.14E+02	1.14E+01
Fe-59	5.84E+00	5.84E-01
Co-58	3.03E+02	3.03E+01
Co-60	2.45E+02	2.45E+01
Zn-65	—	—
Sr-89	4.56E+01	4.56E+00
Sr-90	1.09E+01	1.09E+00
Sr-91	1.16E+00	1.16E-01
Sr-92	9.96E-02	9.96E-03
Ba-140	1.19E+01	1.19E+00
Y-90	1.07E+01	1.07E+00
Y-91m	3.48E-01	3.48E-02
Y-91	5.48E-01	5.48E-02

Table 11.4-3 (Sheet 2 of 2)
Maximum Annual Curie Content of Primary Influent

Isotope	Primary Resin Total Ci/yr	Primary Filter Total Ci/yr
Y-92	4.19E-02	4.19E-03
Y-93	9.07E-05	9.07E-06
La-140	1.07E+01	1.07E+00
Zr-95	—	—
Nb-95	—	—
Mo-99	—	—
Tc-99m	—	—
Ru-103	—	—
Ru-106	—	—
Rh-103m	—	—
Rh-106	—	—
Te-132	—	—
Te-125m	—	—
Te-127m	—	—
Te-127	—	—
Te-129m	—	—
Te-129	—	—
Te-131m	—	—
Total:	3.78E+04	3.78E+03

Note:

Values shown as "—" Ci/yr are those calculated to be lower than 1.0E-10 Ci/yr, and thus considered to have insignificant contributions to total.

Table 11.4-4 (Sheet 1 of 2)
Expected Annual Curie Content of Shipped Primary Wastes

Isotope	Primary Resin Total Ci/yr	Primary Filter Total Ci/yr
Br-83	—	—
Br-84	—	—
Br-85	—	—
I-129	—	—
I-130	—	—
I-131	6.04E-02	6.04E-03
I-132	—	—
I-133	—	—
I-134	—	—
I-135	—	—
Rb-86	—	—
Rb-88	—	—
Rb-89	—	—
Cs-134	2.81E+02	2.81E+01
Cs-136	2.61E-02	2.61E-03
Cs-137	4.61E+02	4.61E+01
Cs-138	—	—
Ba-137m	4.61E+02	4.61E+01
Cr-51	3.37E+00	3.37E-01
Mn-54	8.50E+01	8.50E+00
Mn-56	—	—
Fe-55	9.75E+01	9.75E+00
Fe-59	1.23E+00	1.23E-01
Co-58	8.51E+01	8.51E+00
Co-60	9.29E+01	9.29E+00
Zn-65	2.34E+01	2.34E+00
Sr-89	8.05E-01	8.05E-02
Sr-90	1.13E+00	1.13E-01
Sr-91	—	—
Sr-92	—	—
Ba-140	4.80E-01	4.80E-02
Y-90	1.13E+00	1.13E-01
Y-91m	—	—
Y-91	4.03E-04	4.03E-05

Table 11.4-4 (Sheet 2 of 2)
Expected Annual Curie Content of Shipped Primary Wastes

Isotope	Primary Resin Total Ci/yr	Primary Filter Total Ci/yr
Y-92	—	—
Y-93	—	—
La-140	5.52E-01	5.52E-02
Zr-95	1.09E-04	1.09E-05
Nb-95	1.31E-04	1.31E-05
Mo-99	—	—
Tc-99m	—	—
Ru-103	1.10E-03	1.10E-04
Ru-106	5.38E-02	5.38E-03
Rh-103m	1.11E-03	1.11E-04
Rh-106	5.38E-02	5.38E-03
Te-132	—	—
Te-125m	—	—
Te-127m	—	—
Te-127	—	—
Te-129m	2.10E-05	2.10E-06
Te-129	1.37E-05	1.37E-06
Te-131m	—	—
Total:	1.60E+03	1.60E+02

Note:

Values shown as "—" Ci/yr are those calculated to be lower than 1.0E-10 Ci/yr, and thus considered to have insignificant contributions to total.

Table 11.4-5 (Sheet 1 of 2)
Maximum Annual Curie Content of Shipped Primary Wastes

Isotope	Primary Resin Total Ci/yr	Primary Filter Total Ci/yr
Br-83	—	—
Br-84	—	—
Br-85	—	—
I-129	3.44E-03	3.44E-04
I-130	—	—
I-131	4.10E+02	4.10E+01
I-132	—	—
I-133	6.27E-08	6.27E-09
I-134	—	—
I-135	—	—
Rb-86	9.76E+00	9.76E-01
Rb-88	—	—
Rb-89	—	—
Cs-134	9.31E+03	9.31E+02
Cs-136	3.47E+02	3.47E+01
Cs-137	9.13E+03	9.13E+02
Cs-138	—	—
Ba-137m	9.13E+03	9.13E+02
Cr-51	1.86E+01	1.86E+00
Mn-54	1.10E+02	1.10E+01
Mn-56	—	—
Fe-55	1.12E+02	1.12E+01
Fe-59	3.66E+00	3.66E-01
Co-58	2.26E+02	2.26E+01
Co-60	2.42E+02	2.42E+01
Zn-65	—	—
Sr-89	3.06E+01	3.06E+00
Sr-90	1.09E+01	1.09E+00
Sr-91	—	—
Sr-92	—	—
Ba-140	2.35E+00	2.35E-01
Y-90	1.09E+01	1.09E+00
Y-91m	—	—
Y-91	3.90E-01	3.90E-02

**Table 11.4-5 (Sheet 2 of 2)
Maximum Annual Curie Content of Shipped Primary Wastes**

Isotope	Primary Resin Total Ci/yr	Primary Filter Total Ci/yr
Y-92	—	—
Y-93	—	—
La-140	2.70E+00	2.70E-01
Zr-95	—	—
Nb-95	—	—
Mo-99	—	—
Tc-99m	—	—
Ru-103	—	—
Ru-106	—	—
Rh-103m	—	—
Rh-106	—	—
Te-132	—	—
Te-125m	—	—
Te-127m	—	—
Te-127	—	—
Te-129m	—	—
Te-129	—	—
Te-131m	—	—
Total:	2.91E+04	2.91E+03

Note:

Values shown as "—" Ci/yr are those calculated to be lower than 1.0E-10 Ci/yr, and thus considered to have insignificant contributions to total.

Table 11.4-6 (Sheet 1 of 2)
Expected Annual Curie Content of Secondary Waste as Generated

Isotope	Secondary Resin Total Ci/yr
Na-24	1.83E-02
Cr-51	4.29E-02
Mn-54	2.95E-02
Fe-55	2.35E-02
Fe-59	4.49E-03
Co-58	7.78E-02
Co-60	1.03E-02
Zn-65	9.56E-03
Br-84	2.22E-05
Rb-88	8.99E-05
Sr-89	2.24E-03
Sr-90	2.37E-04
Sr-91	2.11E-04
Y-90	2.06E-04
Y-91	2.53E-04
Y-91m	1.82E-04
Y-93	9.80E-04
Zr-95	6.53E-03
Nb-95	5.19E-03
Nb-95m	4.74E-03
Mo-99	1.52E-02
Tc-99m	1.41E-02
Ru-103	1.13E-01
Ru-106	1.65E+00
Rh-103m	1.39E-01
Rh-106	2.11E+00
Ag-110	2.12E-02
Ag-110m	2.45E-02
Te-129	2.29E-03
Te-129m	2.79E-03
Te-131	1.14E-03
Te-131m	1.42E-03
Te-132	4.74E-04

Table 11.4-6 (Sheet 2 of 2)
Expected Annual Curie Content of Secondary Waste as Generated

Isotope	Secondary Resin Total Ci/yr
I-131	1.70E-01
I-132	7.93E-03
I-133	5.23E-02
I-134	1.18E-03
I-135	2.56E-02
Xe-131m	—
Xe-133	—
Xe-135	—
Cs-134	2.50E-01
Cs-135	4.70E-10
Cs-136	1.48E-02
Cs-137	3.39E-01
Ba-136m	1.39E-02
Ba-137m	3.42E-01
Ba-140	1.17E-01
La-140	1.47E-01
Ce-141	2.13E-03
Ce-143	2.91E-03
Ce-144	7.35E-02
Pr-143	2.04E-03
Pr-144	6.37E-02
Total:	5.96E+00

Note:

Values shown as "—" Ci/yr are those calculated to be lower than 1.0E-10 Ci/yr, and thus considered to have insignificant contributions to total.

Table 11.4-7 (Sheet 1 of 2)
Maximum Annual Curie Content of Secondary Waste as Generated

Isotope	Secondary Resin Total Ci/yr
Na-24	4.62E-04
Cr-51	5.17E-01
Mn-54	3.55E-01
Mn-56	2.24E-01
Fe-55	2.78E-01
Fe-59	5.88E-02
Co-58	9.25E-01
Co-60	1.23E-01
Br-83	3.73E-02
Br-84	1.41E-03
Br-85	1.64E-06
Kr-83m	—
Kr-85	—
Kr-85m	—
Rb-88	4.56E-02
Rb-89	1.53E-03
Sr-89	9.10E-01
Sr-90	5.00E-02
Sr-91	2.13E-02
Sr-92	7.25E-04
Y-90	4.60E-02
Y-91	4.34E-02
Y-91m	2.11E-02
Y-92	2.66E-03
Y-93	1.04E-03
Zr-95	7.74E-02
Nb-95	8.25E-02
Nb-95m	5.52E-02
Mo-99	1.52E+01
Tc-99m	1.68E+01
Ru-103	6.28E-02
Ru-103m	3.87E-02
Rh-103m	6.29E-02
Rh-106	5.95E-02

Table 11.4-7 (Sheet 2 of 2)
Maximum Annual Curie Content of Secondary Waste as Generated

Isotope	Secondary Resin Total Ci/yr
Ag-110	1.34E-02
Ag-110m	2.24E-01
Te-129	1.19E+00
Te-129m	1.10E+00
Te-131	2.35E+00
Te-131m	2.01E-01
Te-132	6.75E+00
Te-134	1.49E-03
I-130	1.19E-01
I-131	1.37E+02
I-132	6.77E+00
I-133	2.51E+01
I-134	4.99E-02
I-135	3.99E+00
Xe-131m	—
Xe-133	—
Xe-135	—
Cs-134	6.90E+02
Cs-135	6.16E-08
Cs-136	5.15E+02
Cs-137	5.00E+02
Cs-138	3.41E-02
Ba-136m	6.35E+02
Ba-137m	5.14E+02
Ba-140	2.83E-01
La-140	3.31E-01
Ce-141	6.42E-02
Ce-143	4.94E-03
Ce-144	6.33E-02
Pr-143	4.63E-02
Pr-144	6.33E-02
Total:	3.08E+03

Note:

Values shown as "—" Ci/yr are those calculated to be lower than 1.0E-10 Ci/yr, and thus considered to have insignificant contributions to total.

Table 11.4-8 (Sheet 1 of 2)
Expected Annual Curie Content of Shipped Secondary Wastes

Isotope	Secondary Resin Total Ci/yr
Na-24	—
Cr-51	4.55E-03
Mn-54	2.40E-02
Fe-55	2.19E-02
Fe-59	1.14E-03
Co-58	3.25E-02
Co-60	9.95E-03
Zn-65	7.42E-03
Br-84	—
Rb-88	—
Sr-89	6.86E-04
Sr-90	2.36E-04
Sr-91	—
Y-90	2.31E-04
Y-91	6.71E-09
Y-91m	—
Y-93	—
Zr-95	2.52E-03
Nb-95	4.06E-03
Nb-95m	2.32E-03
Mo-99	—
Tc-99m	—
Ru-103	2.34E-02
Ru-106	1.38E+00
Rh-103m	2.87E-02
Rh-106	1.77E+00
Ag-110	1.66E-02
Ag-110m	1.92E-02
Te-129	3.44E-04
Te-129m	4.48E-04
Te-131	—
Te-131m	—

Table 11.4-8 (Sheet 2 of 2)
Expected Annual Curie Content of Shipped Secondary Wastes

Isotope	Secondary Resin Total Ci/yr
Te-132	—
I-131	7.32E-05
I-132	—
I-133	—
I-134	—
I-135	—
Xe-131m	—
Xe-133	—
Xe-135	—
Cs-134	2.31E-01
Cs-135	4.86E-10
Cs-136	1.56E-04
Cs-137	3.36E-01
Ba-136m	1.47E-04
Ba-137m	3.40E-01
Ba-140	8.97E-04
La-140	1.05E-03
Ce-141	3.13E-04
Ce-143	—
Ce-144	5.91E-02
Pr-143	2.38E-05
Pr-144	5.12E-02
Total:	4.38E+00

Note:

Values shown as “—” Ci/yr are those calculated to be lower than 1.0E-10 Ci/yr, and thus considered to have insignificant contributions to total.

Table 11.4-9 (Sheet 1 of 2)
Maximum Annual Curie Content of Shipped Secondary Wastes

Isotope	Secondary Resin Total Ci/yr
Na-24	—
Cr-51	5.47E-02
Mn-54	2.89E-01
Mn-56	—
Fe-55	2.60E-01
Fe-59	1.50E-02
Co-58	3.87E-01
Co-60	1.19E-01
Br-83	—
Br-84	—
Br-85	—
Kr-83m	—
Kr-85	—
Kr-85m	—
Rb-88	—
Rb-89	—
Sr-89	2.79E-01
Sr-90	4.96E-02
Sr-91	—
Sr-92	—
Y-90	5.12E-02
Y-91	1.12E-06
Y-91m	—
Y-92	—
Y-93	—
Zr-95	2.98E-02
Nb-95	5.19E-02
Nb-95m	2.70E-02
Mo-99	2.72E-09
Tc-99m	3.04E-09
Ru-103	1.30E-02
Ru103m	3.27E-02

Table 11.4-9 (Sheet 2 of 2)
Maximum Annual Curie Content of Shipped Secondary Wastes

Isotope	Secondary Resin Total Ci/yr
Rh-103m	1.30E-02
Rh-106	5.03E-02
Ag-110	1.05E-02
Ag-110m	1.76E-01
Te-129	1.92E-01
Te-129m	1.77E-01
Te-131	—
Te-131m	—
Te-132	2.90E-08
Te-134	—
I-130	—
I-131	5.94E-02
I-132	2.36E-08
I-133	—
I-134	—
I-135	—
Xe-131m	—
Xe-133	—
Xe-135	—
Cs-134	6.35E+02
Cs-135	6.36E-08
Cs-136	5.42E+00
Cs-137	4.98E+02
Cs-138	—
Ba-136m	6.69E+00
Ba-137m	5.11E+02
Ba-140	2.18E-03
La-140	2.87E-03
Ce-141	9.41E-03
Ce-143	—
Ce-144	5.08E-02
Pr-143	4.75E-04
Pr-144	5.08E-02
Total:	1.66E+03

Note:

Values shown as "—" Ci/yr are those calculated to be lower than 1.0E-10 Ci/yr, and thus considered to have insignificant contributions to total.

Table 11.4-10 (Sheet 1 of 2)
Component Data — Solid Waste Management System (Nominal)

Tanks	
Spent resin tank	
Number	2
Total volume (ft ³)	300
Type	Vertical, conical bottom, dished top
Design pressure (psig)	15
Design temperature (°F)	150
Material	Stainless steel
Pumps	
Resin mixing pump	
Number	1
Type	Pneumatic diaphragm
Design pressure (psig)	125
Design temperature (°F)	150
Design flow rate (gpm)	100
Air supply pressure (psig)	100
Air consumption (scfm)	130
Material	Stainless steel housing, Buna N diaphragms
Resin transfer pump	
Number	1
Type	Material handling positive displacement
Design pressure (psig)	125
Design temperature (°F)	150
Design flow rate (gpm)	100
Material	Stainless steel housing, Buna N flexible parts

Table 11.4-10 (Sheet 2 of 2)
Component Data — Solid Waste Management System (Nominal)

Filters	
Resin fines filter	
Number	1
Type	Filter cartridge for inside to outside flow
Design pressure (psig)	150
Design temperature (°F)	150
Design flowrate (gpm)	120
Filtration rating	10 microns
Material	Stainless steel housing and pleated polypropylene cartridge with stainless steel screen outer jacket
Sampler	
Resin sampling device	
Number	1
Type	Inline sampler, positive displacement sample collection and portable pig for sample jar
Material	Stainless steel and EPDM wetted parts

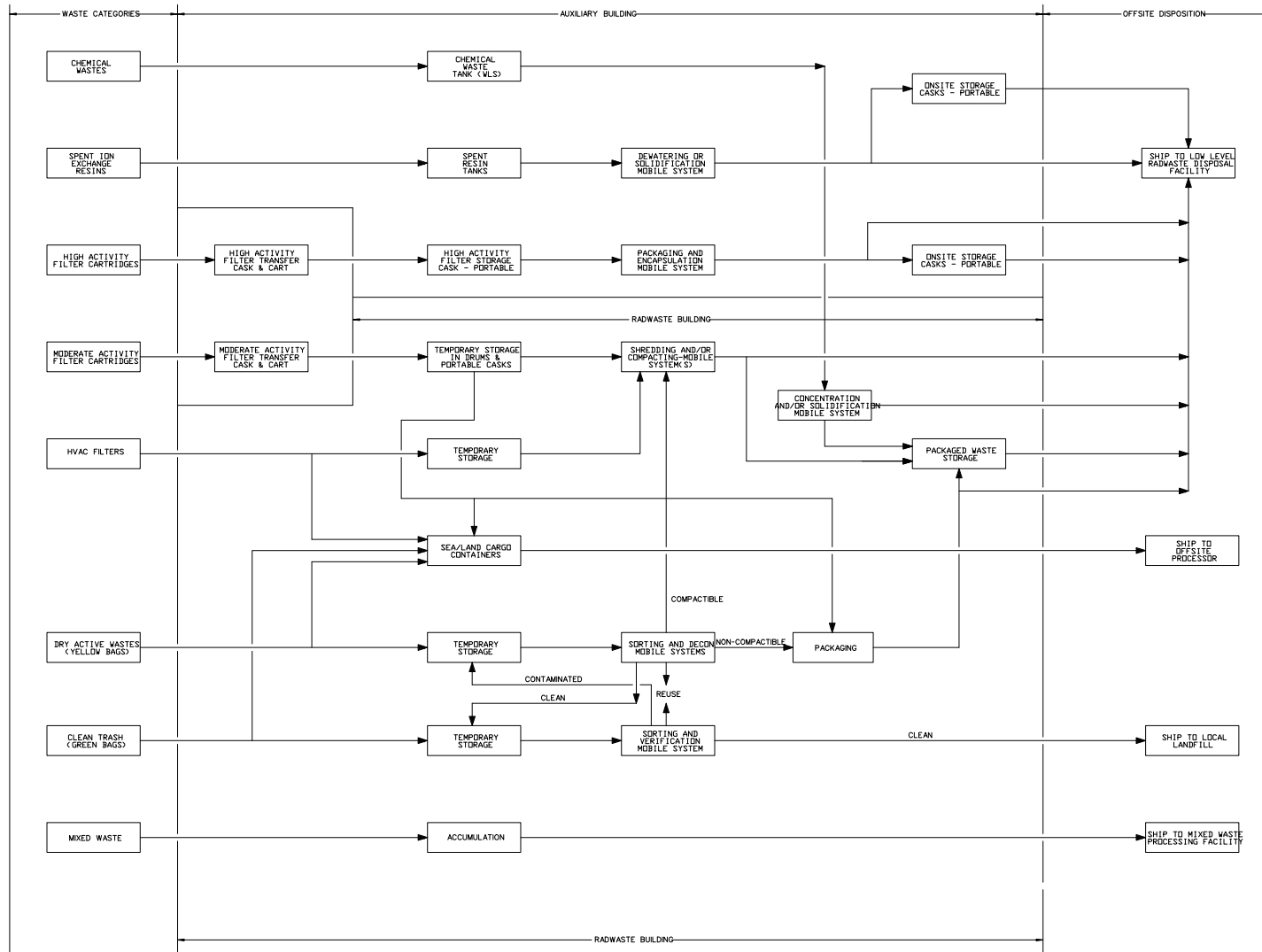

Figure 11.4-1
Waste Processing System
Flow Diagram

11.5 Radiation Monitoring

The radiation monitoring system (RMS) provides plant effluent monitoring, process fluid monitoring, airborne monitoring, and continuous indication of the radiation environment in plant areas where such information is needed. Radiation monitors that have a safety-related function are qualified environmentally, seismically, or both. Class 1E radiation monitors conform to the separation criteria described in [Subsection 8.3.2](#) and to the fire protection criteria described in [Subsection 9.5.1](#). Equipment qualification requirements, including seismic qualification requirements, and general location information for radiation monitors are listed in [Section 3.11](#). Seismic Categories for the buildings housing radiation monitors are listed in [Section 3.2](#).

The radiation monitoring system is installed permanently and operates in conjunction with regular and special radiation survey programs to assist in meeting applicable regulatory requirements. The radiation monitoring system is designed in accordance with ANSI N13.1-1969. The process monitors are designed in accordance with ANSI-N42.18-1980.

The radiation monitoring system is divided functionally into two subsystems:

- Process, airborne, and effluent radiological monitoring and sampling
- Area radiation monitoring

11.5.1 Design Basis

11.5.1.1 Safety Design Basis

While the radiation monitoring system is primarily a surveillance system, certain detector channels perform safety-related functions. The components used in these channels meet the qualification requirements for safety-related equipment as described in [Subsection 7.1.4](#).

Channel and equipment redundancy is provided for safety-related monitors to maintain the safety-related function in case of a single failure.

The design objectives of the radiation monitoring system during postulated accidents are:

- Initiate containment air filtration isolation in the event of abnormally high radiation inside the containment (High-1)
- Initiate normal residual heat removal system suction line containment isolation in the event of abnormally high radiation inside the containment (High-2)
- Initiate main control room supplemental filtration in the event of abnormally high gaseous radioactivity in the main control room supply air
- Initiate main control room ventilation isolation and actuate the main control room emergency habitability system in the event of abnormally high particulate or iodine radioactivity in the main control room supply air
- Provide long-term post-accident monitoring (using both safety-related and nonsafety-related monitors)

The scope of the radiation monitoring system for post-accident monitoring is set forth in General Design Criterion 64 and in the provisions of Regulatory Guide 1.97.

11.5.1.2 Power Generation Design Basis

The radiation monitoring system is designed to support the requirements of 10 CFR 20 and to provide:

- Equipment to meet the applicable regulatory requirements for both normal operation and transient events
- Data to aid plant health physics personnel in limiting release of radioactivity to the environment and limiting exposure of operation and maintenance personnel to meet ALARA (as-low-as-reasonably-achievable) guidance
- Early indication of a system or equipment malfunction that could result in excessive radiation dose to plant personnel or lead to plant damage
- [Data collection and data storage to support compliance reporting for the applicable NRC requirements and guidelines, such as General Design Criterion 64 and Regulatory Guide 1.21 and Regulatory Guide 4.15, Revision 1.](#)
- Exhausts to the environment from the personnel areas in the annex building, electrical and mechanical equipment rooms in the annex and auxiliary buildings, and the diesel generator rooms will not be radioactive because they contain no radioactive materials. These ventilation exhausts are not monitored.

11.5.2 System Description

11.5.2.1 Radiation Monitoring System

The radiation monitoring system uses distributed radiation monitors, where each radiation monitor consists of one or more radiation detectors and a dedicated radiation processor.

Each radiation processor receives, averages and stores radiation data and transmits alarms and data to the plant control system (protection and safety monitoring system for safety-related monitors) for control (as required), display and recording. These alarms include: low (fail), alert, and high. Selected channels have a rate-of-rise alarm. Storage of radiation readings is provided.

Each radiation detector, except the in-duct radiation detectors and the containment high range ion chambers, has a check source that is actuated from the associated local radiation processor. The check source is used to verify detector and monitor operation. The check source is shielded to meet ALARA requirements, and returns to its fully retracted/shielded position upon loss of actuator power. Check sources on detectors can be actuated from the main control room. The in-duct radiation detector operation may be checked using an internal LED to simulate light pulses emitted in response to radiation. The containment high range monitors have an internal source that provides a minimum reading; loss of signal from the detector indicates detector inoperability.

Radiation monitoring data, including alarm status, are provided to AP1000 operators via the plant control system (and the protection and safety monitoring system for Class 1E monitors). The information is available in either counts per minute (count rate), microCuries/cc (activity concentration), or R/hr (radiation dose rate).

Safety-related channels are environmentally qualified and are powered from the Class 1E dc and uninterruptible power supply system. Nonsafety-related channels are powered from the non-Class 1E dc and uninterruptible power supply system.

11.5.2.2 Monitor Functional Description

The process and effluent radiological monitoring and sampling subsystem provides radiation monitoring for the four functional classifications listed below. Individual monitors may provide functionality in more than one of these classifications.

- Fluid process monitors determine concentrations of radioactive material in plant fluid systems
- Airborne monitors provide operators with information on concentrations of radioactivity at various points in the ventilation system, providing information on airborne concentrations in the plant
- Liquid and gaseous effluent monitors measure radioactive materials discharged to the environs
- Post-accident monitors monitor potential pathways for release of radioactive materials during accident conditions

The area radiation monitoring subsystem provides plant personnel information on radiation at fixed locations in AP1000. Post-accident monitoring functions are also performed by certain area monitors.

11.5.2.3 Monitor Descriptions

For offline gaseous monitors, the radiation monitor includes a low pressure drop flow sensor suitable for measuring the sample flow. The radiation processor receives an analog signal input from this flow sensor. This signal is used by the radiation processor to control sample flow. The analog signal is transmitted to the plant control system (protection and safety monitoring system for safety-related monitors). For offline liquid monitors, a flow indicator is provided for manual adjustment of the flow.

Those airborne radiation monitors which monitor plant areas which may be occupied by plant personnel will be capable of detecting 10 DAC-hours. The specific radiation monitors which are included in this category are identified in [Table 11.5-1](#).

11.5.2.3.1 Fluid Process Monitors

Steam Generator Blowdown Radiation Monitors

The steam generator blowdown radiation monitors (BDS-JE-RE010, RE011) measure the concentration of radioactive material in the blowdown from the steam generators. One measures radiation in the purification process effluent before it is returned to the condensate system. The other measures radioactivity in the blowdown system electrodeionization waste brine before it is discharged to the waste water system. The presence of radioactive material in the steam generator blowdown indicates a leak between the primary side and the secondary side of the steam generator. Refer to [Subsection 5.2.5](#) for details of leakage monitoring and to [Subsections 10.4.8](#) and [11.2](#) for process system details. The steam generator blowdown radiation monitors meet the guidelines of Regulatory Guide 1.97 as discussed in [Appendix 1A](#) and [Section 7.5](#).

AP1000 has two steam generators, each of which has a blowdown line. Each blowdown line has a heat exchanger upstream of the blowdown flow control valve. The steam generator blowdown radiation detectors are located in the lines downstream of these heat exchangers. Therefore, the radiation monitors do not require a sample cooler.

When its predetermined setpoint is exceeded, each steam generator blowdown radiation monitor initiates an alarm in the main control room, initiates closure of the steam generator blowdown

containment isolation valves and the steam generator blowdown flow control valves, and diverts flow to the liquid radwaste system.

The steam generator blowdown radiation monitors use inline gamma-sensitive, thallium-activated, sodium iodide scintillation detectors. The steam generator blowdown radiation monitor detector range and principal isotopes are listed in [Table 11.5-1](#).

The arrangement for the steam generator blowdown radiation monitor is shown in [Figure 11.5-1](#).

Component Cooling Water System Radiation Monitor

The component cooling water system radiation monitor (CCS-JE-RE001) measures the concentration of radioactive material in the component cooling water system. Radioactive material in the component cooling water system provides indication of leakage. Refer to [Subsection 5.2.5](#) for details of leakage monitoring and to [Subsection 9.2.2](#) for process system details.

If the concentration of radioactive materials exceeds a predetermined setpoint, the component cooling water system radiation monitor initiates an alarm in the main control room.

The component cooling water system radiation monitor is an offline monitor that uses a gamma-sensitive, thallium-activated, sodium iodide scintillation detector. The range and principal isotopes are listed in [Table 11.5-1](#).

The arrangement for the component cooling water system radiation monitor is shown in [Figure 11.5-7](#).

Main Steam Line Radiation Monitors

The main steam line radiation monitors (SGS-JE-RE026A/B and SGS-JE-RE027A/B) measure the concentration of radioactive materials in the two main steam lines. Additionally, the main steam line radioisotope concentration data are used to calculate releases to the environment if the steam generator safety relief or power operated relief valves release steam to the atmosphere. Each main steam line radiation monitor meets the guidelines of Regulatory Guide 1.97 as discussed in [Appendix 1A](#) and [Section 7.5](#). If the concentration of radioactive materials exceeds a predetermined setpoint, the main steam line radiation monitors initiate alarms in the main control room.

The main steam line radiation monitors are positioned adjacent to the steam lines. Each monitor detector shield is arranged so that the detector sensitive volume is exposed to the radiation originating inside the steam line on which it is located, and is shielded from radiation originating in the other steam line. Radioactive material in the main steam line provides early indication of leakage in the form of a steam generator tube leak. Refer to [Subsection 5.2.5](#) for details of leakage monitoring and to [Section 10.3](#) for process system details.

The main steam line radiation monitor detectors use gamma-sensitive detectors.

Each main steam line radiation monitor range and principal isotopes are listed in [Table 11.5-1](#).

The arrangement for a main steam line radiation monitor is shown in [Figure 11.5-8](#).

Service Water Blowdown Radiation Monitor

The service water blowdown radiation monitor (SWS-JE-RE008) measures the concentration of radioactive materials in the blowdown flow from the service water system. Upstream of the radiation monitor, local grab sampling is available.

The service water blowdown radiation monitor initiates an alarm in the main control room if the concentration of radioactive materials exceeds a predetermined setpoint. Following the alarm, the operator can manually isolate the blowdown flow. Refer to [Subsection 9.2.1](#) for system details.

The service water blowdown monitor is an inline monitor using a gamma-sensitive, thallium-activated, sodium iodide scintillation detector. The range and principal isotopes are listed in [Table 11.5-1](#).

The arrangement for the service water blowdown radiation monitor is shown in [Figure 11.5-1](#).

Primary Sampling System Liquid Sample Radiation Monitor

The primary sampling system (PSS) liquid sample radiation monitor (PSS-JE-RE050) measures and indicates the concentration of radioactive materials in the samples from the reactor coolant system. The liquid sample radiation monitor's primary function is to indicate elevated sample radiation levels following a design basis or severe accident. High radiation levels show the need for sample dilution to limit operator exposure during sampling and sample transport for analysis. The monitor may also be used to provide early indication of a significant increase in the radioactivity of the reactor coolant indicating a possible fuel cladding breach. When a predetermined setpoint is exceeded, the primary sampling system liquid sample radiation monitor isolates the sample flow by closing the outside containment isolation valve and initiates an alarm in the main control room and locally to alert the operator. Refer to [Subsection 9.3.3](#) for system details.

The primary sampling system liquid sample radiation monitor utilizes a gamma-sensitive radiation detector that is adjacent to the sampling line immediately downstream of the sample cooler. The range and principal isotopes are listed in [Table 11.5-1](#).

The arrangement for the primary sampling system liquid sample radiation monitor is shown in [Figure 11.5-8](#).

Primary Sampling System Gaseous Sample Radiation Monitor

The primary sampling system gaseous sample radiation monitor (PSS-JE-RE052) measures the concentration of radioactive materials in the gaseous samples taken from containment atmosphere. The gaseous sample radiation monitor is used to provide indication of significant radioactivity in the gaseous sample being taken and the need for dilution of the sample to limit operator exposure during sampling and transport for analysis. When a predetermined setpoint is exceeded, the primary sampling system gaseous sample radiation monitor initiates an alarm locally and in the main control room to alert the operator. Refer to [Subsection 9.3.3](#) for system details.

The primary sampling system gaseous sample radiation monitor utilizes a gamma-sensitive radiation detector that is adjacent to the sampling line immediately upstream of the sample bottle. The range and principal isotopes are listed in [Table 11.5-1](#).

The arrangement for the primary sampling system gaseous sample radiation monitor is shown in [Figure 11.5-8](#).

Main Control Room Supply Air Duct Radiation Monitors

The main control room supply air duct radiation monitors (particulate detectors VBS-JE-RE001A and VBS-JE-RE001B, iodine detectors VBS-JE-RE002A and VBS-JE-RE002B, and noble gas detectors VBS-JE-RE003A and VBS-JE-RE003B) are offline monitors that continuously measure the concentration of radioactive materials in the air that is supplied to the main control room by the nuclear island nonradioactive ventilation system air handling units. The control support area ventilation is also part of this air supply system. The air supply is partially outside air. Refer to [Subsection 9.4.1](#) for system details. The main control room supply air duct radiation monitors receive

safety-related power. When predetermined setpoints are exceeded, the monitors provide signals to initiate the supplemental air filtration system on high gaseous concentration, and to isolate the main control room air intake and exhaust ducts and activate the main control room emergency habitability system on high particulate or iodine concentrations. Alarms are also provided in the main control room for these high concentrations.

The main control room supply air duct radiation monitor components are qualified environmentally and seismically in accordance with the guidelines of Regulatory Guides 1.89 and 1.100, respectively. Each monitor meets the guidelines of Regulatory Guide 1.97 as discussed in [Appendix 1A](#) and [Section 7.5](#).

The particulate detectors are beta-sensitive scintillation detectors that view a fixed filter. The iodine detectors are gamma-sensitive, thallium-activated, sodium iodide scintillation detectors that view a fixed charcoal filter. The gas detectors are beta-sensitive scintillation detectors. The range and principal radioisotopes are listed in [Table 11.5-1](#).

The arrangement for a main control room supply air duct radiation monitor is shown in [Figure 11.5-6](#).

Containment Air Filtration Exhaust Radiation Monitor

The containment air filtration exhaust radiation monitor (VFS-JE-RE001) measures the concentration of radioactive materials in the containment purge exhaust air.

The monitor provides an alarm in the main control room when the concentration of radioactive gases in the exhaust exceeds a predetermined setpoint. Refer to [Subsection 9.4.7](#) for system details.

The containment air filtration exhaust radiation monitor is an inline monitor that uses a beta-sensitive scintillation detector. It is located downstream of the containment air filtration units with its sensitive volume inside the duct. The detector range and principal radioisotopes are listed in [Table 11.5-1](#).

The arrangement of the containment air filtration exhaust radiation monitor is shown in [Figure 11.5-5](#).

Gaseous Radwaste Discharge Radiation Monitor

The gaseous radwaste discharge radiation monitor (WGS-JE-RE017) measures the concentration of radioactive materials in the releases from the gaseous radwaste system to the plant vent. The measurement is made before the discharge reaches the plant vent or is diluted by any other flows.

The gaseous radwaste discharge radiation monitor provides an alarm in the main control room and terminates the release of radioactive gas to the plant vent by closing the discharge isolation valve when a predetermined setpoint is exceeded. Refer to [Section 11.3](#) for system details.

The monitor is an inline monitor using a beta-sensitive scintillation detector with its sensitive volume inside the piping. The range and principal isotopes are listed in [Table 11.5-1](#).

The arrangement for the gaseous radwaste discharge radiation monitor is shown in [Figure 11.5-1](#).

Containment Atmosphere Radiation Monitor

The containment atmosphere radiation monitor measures the radioactive gaseous (PSS-JE-RE026) and F18 particulate (PSS-JE-RE027) concentrations in the containment atmosphere. The containment atmosphere radiation monitor is a part of the reactor coolant pressure boundary leak detection system described in [Subsection 5.2.5](#). The presence of gaseous or F18 radioactivity in the containment atmosphere is an indication of reactor coolant pressure boundary leakage. Refer to [Subsection 5.2.5](#) for further details. Conformance with Regulatory Guide 1.45 is discussed in [Appendix 1A](#).

The containment atmosphere radiation monitor accepts analog signal inputs for sample flow and temperature. These signals are used to calculate concentrations at standard conditions.

The radiogas detector is a beta-sensitive scintillation detector. The F18 particulate detector is also a beta-sensitive scintillation detector. The ranges and principal isotopes are listed in [Table 11.5-1](#).

The arrangement for the containment atmosphere radiation monitor is shown in [Figure 11.5-3](#).

11.5.2.3.2 Airborne Monitors

Fuel Handling Area Exhaust Radiation Monitor

The fuel handling area exhaust radiation monitor (VAS-JE-RE001) measures the concentration of radioactive materials in the exhaust air from the fuel handling area. This radiation monitor is located upstream of the exhaust air isolation damper.

When a predetermined setpoint is exceeded, the fuel handling area exhaust radiation monitor provides signals to alarm in the main control room, to initiate closure of the fuel handling area supply and exhaust air isolation dampers, to open the fuel handling area exhaust air isolation damper to the containment air filtration exhaust units, and to start a containment air filtration exhaust unit. These actions provide a filtered air path from the fuel handling area to the plant vent. Refer to [Subsection 9.4.3](#) for system details.

The fuel handling area exhaust radiation monitor is an inline monitor that uses a beta-sensitive scintillation detector. It is located with the sensitive volume inside the exhaust duct. The range and principal isotopes are listed in [Table 11.5-1](#).

The arrangement for the fuel handling area exhaust radiation monitor is shown in [Figure 11.5-5](#).

Auxiliary Building Exhaust Radiation Monitor

The auxiliary building exhaust radiation monitor (VAS-JE-RE002) measures the concentration of radioactive materials in the radiologically controlled area ventilation system exhaust air from the auxiliary building. The auxiliary building radiation monitor detector is upstream of the exhaust air isolation damper.

When a predetermined setpoint is exceeded, indicating abnormal airborne radiation, the auxiliary building exhaust radiation monitor provides signals to alarm in the main control room, to initiate closure of the auxiliary building supply and exhaust air isolation dampers, to open the auxiliary building exhaust air isolation damper to the containment air filtration exhaust units, and to start a containment air filtration exhaust unit. These actions provide a filtered air path from the auxiliary building to the plant vent. Refer to [Subsection 9.4.3](#) for system details.

The auxiliary building exhaust radiation monitor is an inline monitor that uses a beta-sensitive scintillation detector. It is located with the sensitive volume inside the exhaust duct. The range and principal isotopes are listed in [Table 11.5-1](#).

The arrangement for the auxiliary building exhaust radiation monitor is shown in [Figure 11.5-5](#).

Annex Building Exhaust Radiation Monitor

The annex building exhaust radiation monitor (VAS-JE-RE003) measures the concentration of radioactive materials in the radiologically controlled area ventilation system exhaust air from the annex building. The annex building exhaust radiation monitor is located upstream of the annex building exhaust air isolation damper.

When a predetermined setpoint is exceeded, indicating abnormal airborne radiation, the annex building exhaust radiation monitor provides signals to alarm in the main control room, to initiate closure of the annex building supply and exhaust air isolation dampers, to open the annex building exhaust air isolation damper to the containment air filtration units, and to start a containment air filtration exhaust unit. These actions provide a filtered air path from the annex building to the plant vent. Refer to [Subsection 9.4.3](#) for system details.

The annex building monitor is an inline monitor that uses a beta-sensitive scintillation detector. It is located with the sensitive volume inside the exhaust duct. The range and principal isotopes are listed in [Table 11.5-1](#).

The arrangement for the annex building exhaust radiation monitor is shown in [Figure 11.5-5](#).

Health Physics and Hot Machine Shop Exhaust Radiation Monitor

The health physics and hot machine shop exhaust radiation monitor (detector VHS-JE-RE001) measures the concentration of radioactive materials in the exhaust air from the health physics area and the hot machine shop. The monitor provides an alarm in the main control room when the concentration of radioactive gases in the exhaust exceeds a predetermined setpoint. Refer to [Subsection 9.4.11](#) for system details.

The monitor is an offline monitor, located downstream of the exhaust fans, that uses a beta-sensitive scintillation detector viewing a fixed particulate filter. The range and principal isotopes are listed in [Table 11.5-1](#).

The arrangement for the health physics and hot machine shop exhaust radiation monitor is shown in [Figure 11.5-9](#).

Radwaste Building Exhaust Radiation Monitor

The radwaste building exhaust radiation monitor (VRS-JE-RE023) measures the concentration of radioactive materials in the exhaust air from the radwaste building. The monitor provides an alarm in the main control room when radioactive material concentrations in the exhaust duct exceed a predetermined setpoint. Refer to [Subsection 9.4.8](#) for system details.

The monitor is an offline monitor, located downstream of the exhaust fans, that uses a beta-sensitive scintillation detector viewing a fixed particulate filter. The range and principal isotopes are listed in [Table 11.5-1](#).

The arrangement for the radwaste building exhaust radiation monitor is shown in [Figure 11.5-9](#).

11.5.2.3.3 Liquid and Gaseous Effluent Monitors

Plant Vent Radiation Monitor

The plant vent radiation monitor measures the concentration of radioactive airborne contamination being released through the plant vent, which is the only design pathway for the release of radioactive materials to the atmosphere. The plant vent radiation monitor sample is provided using an isokinetic sampling nozzle assembly that has flow sensors. Heat tracing is provided for the sample line. The monitor also provides particulate, iodine, and gaseous grab sampling capability.

The plant vent is sampled continuously for the full range of concentrations between normal conditions and those postulated in Regulatory Guide 1.97. The plant vent radiation monitor is a post-accident monitor and meets the guidelines of Regulatory Guide 1.97 and NUREG-0737 as discussed in [Appendix 1A](#) and [Section 7.5](#). Alarms are provided in the main control room if radioactivity concentrations exceed predetermined setpoints. The plant vent radiation monitor also provides data

for plant effluent release reports identified in Regulatory Guide 1.21. For further process details, refer to [Subsection 11.3.3](#).

The normal range particulate detector, VFS-JE-RE101, uses a beta-sensitive scintillation detector that views a fixed filter. The accident range particulate filter is fixed and identical to the normal range filter. The accident range particulate filter is analyzed in an onsite laboratory.

The normal range iodine detector, VFS-JE-RE102, is a gamma-sensitive, thallium-activated, sodium iodide, scintillation detector that views a fixed charcoal filter. The accident range iodine filter is a fixed silver zeolite filter. The accident range iodine filter is analyzed in an onsite laboratory.

The three radiogas channels measure the entire specified range, with overlap in the detector ranges. The normal range radiogas detector, VFS-JE-RE103, is a beta-sensitive scintillation detector. The accident range radiogas detectors, VFS-JE-RE104A (mid-range) and VFS-JE-RE104B (high-range), are beta/gamma-sensitive detectors with small sensitive volumes compared to the normal range radiogas detector.

The plant vent radiation monitor detector ranges and principal radioisotopes are listed in [Table 11.5-1](#). The arrangement for the plant vent radiation monitor is shown in [Figure 11.5-4](#).

The plant vent radiation monitor accepts analog signal inputs from process and sample sensors for plant vent effluent flow and temperature. These signals are used to control the sample flow to maintain isokinetic extraction at the sample nozzles, and to calculate concentrations, releases and flow rates at standard conditions. These analog signals are also used to calculate total process flow, total sample flow, and total discharge for an operator-selected period.

The normal range particulate, iodine, and radiogas detectors are deactivated automatically when the gas channel concentration exceeds the normal range. The sample flow bypasses the normal range detectors and a small portion is extracted for the accident range particulate and iodine sample filters and radiogas detectors. This prevents normal range detector damage and allows these detectors to be used to measure the concentrations after they decrease again to within the normal range detector ranges.

The following design criteria for particulate and iodine collection are applied to the design of the plant vent and vent sampling system:

- The sample extraction point is located at a sufficient distance downstream of perturbations or flow entry points to provide fully developed flow in the turbulent regime.
- The sample extraction point is located between the discharge plane of a fan and the stack exit plane, and is not located close to the stack exit plane where wind effects significantly influence the velocity profile at the sampling location.
- The sample nozzles provide high efficiency transmission ratios (80 to 130%) and an aspiration ratio of 0.80 to 1.50 over the expected normal and off-normal flow range for 10 micron aerodynamic diameter (AD) particles.
- The sample line layout includes features to provide particle transport efficiency, including the following:
 - Non-reactive materials are used in the construction of sample lines.
 - Sample line deposition analyses are performed.

- The distance between the sampling nozzles and the sample collection stations is minimized, within the requirements of the overall layout requirements.
- Long horizontal runs are avoided.
- Long radius bends are used.
- Heat tracing is included if needed to avoid condensation of water or iodine.

Turbine Island Vent Discharge Radiation Monitor

The turbine island vent discharge radiation monitor (TDS-JE-RE001A/B) measures the concentration of radioactive gases in the steam and non-condensable gases that are discharged by the condenser vacuum pumps and the gland seal steam condenser. This measurement provides early indication of leakage between the primary and secondary sides of the steam generators. The monitor provides an alarm in the main control room if concentrations exceed a predetermined setpoint. Refer to [Subsection 5.2.5](#) for leakage monitoring details and to [Subsections 10.4.2](#) and [10.4.3](#) for process system details. The turbine island vent discharge radiation monitor meets the guidelines of Regulatory Guide 1.97 as discussed in [Appendix 1A](#) and [Section 7.5](#).

The turbine island vent discharge radiation monitor provides data for reports of gaseous releases of radioactive materials in accordance with Regulatory Guide 1.21. The monitor is an inline monitor that uses two beta/gamma-sensitive Geiger-Mueller tubes with overlap in the detector ranges. The range and principal isotopes are listed in [Table 11.5-1](#).

The arrangement for the turbine island vent discharge radiation monitor is shown in [Figure 11.5-1](#).

Liquid Radwaste Discharge Radiation Monitor

The liquid radwaste discharge radiation monitor (WLS-JE-RE229) measures the concentration of radioactive materials in liquids released to the environment. The liquid releases are made in batches that are mixed thoroughly and sampled. The samples are analyzed on site before discharge to determine that the discharge is within allowable concentration limits and within allowable totals.

The liquid radwaste discharge radiation monitor provides data for reports of liquid releases of radioactive materials in accordance with Regulatory Guide 1.21.

The liquid radwaste discharge radiation monitor is an inline monitor that provides signals to isolate the discharge of liquid radwaste, stop the liquid radwaste system discharge pumps and alarms in the main control room if the concentrations exceed a predetermined setpoint. For process system details refer to [Section 11.2](#).

The range and principal isotopes are listed in [Table 11.5-1](#). The detector is a gamma-sensitive, thallium-activated, sodium iodide scintillation detector.

The arrangement for the liquid radwaste discharge radiation monitoring channel is shown in [Figure 11.5-1](#).

Waste Water Discharge Radiation Monitor

The waste water discharge radiation monitor (WWS-JE-RE021) measures the concentration of radioactive materials in the discharge from the waste water system. The waste water discharge radiation monitor provides data for reports of liquid releases of radioactive materials in accordance with Regulatory Guide 1.21.

The waste water discharge radiation monitor is an inline monitor. It stops the turbine building sump pumps and initiates an alarm in the main control room if the concentration of radioactive materials exceeds a predetermined setpoint. Following an alarm, the operator can manually realign the discharge to the liquid radwaste system for processing. For process system details refer to [Subsection 9.2.9](#).

The range and principal isotopes are listed in [Table 11.5-1](#). The detector is a gamma-sensitive, thallium-activated, sodium iodide scintillation detector.

The arrangement for the waste water discharge radiation monitor is shown in [Figure 11.5-1](#).

11.5.2.4 Inservice Inspection, Calibration, and Maintenance

The operability of each radiation monitoring system channel is checked periodically.

Test and inspection requirements for safety-related channels and certain nonsafety-related channels are provided in the Technical Specifications, [Chapter 16](#).

Daily checks of effluent monitoring system operability are made by observing channel behavior. Detector response is routinely observed with a remotely-positioned check source in accordance with plant procedures. Instrument background count rate is also observed to determine proper functioning of the monitors. Any detector whose response cannot be verified by observation during normal operation or by using the remotely-positioned check source can have its response checked with a portable check source. A record is maintained showing the background radiation level and the detector response.

Calibration of the continuous radiation monitors is done with commercial radionuclide standards that have been standardized using a measurement system traceable to the National Institute of Standards and Technology.

11.5.3 Effluent Monitoring and Sampling

The primary means of quantitatively evaluating the isotopic activities in effluent paths is a program of sampling and onsite laboratory measurements. Gross activity measurements provided by the radiation monitors described in [Subsection 11.5.2.3](#) are used to determine the activities released in effluent paths by calibrating the monitors against normalized laboratory results.

Sample points are located on the gaseous effluent radiation monitor skids.

The requirements of General Design Criterion 64 are satisfied by the sampling program and the effluent radiation monitors described in [Subsection 11.5.2.3](#).

SNC is extending the existing SNC program for quality assurance of radiological effluent and environmental monitoring that is based on Regulatory Guide 4.15, Revision 1, to apply to Vogtle Units 3 and 4. Regulatory Guide 4.15, Revision 1, is a proven methodology for quality assurance of radiological effluent and environmental monitoring programs that is acceptable to the NRC staff as a method for demonstrating compliance with applicable requirements of 10 CFR Parts 20, 50, 52, 61, and 72. Use of Revision 2 of Regulatory Guide 4.15 would necessitate conducting two separate programs involving the use of common staff facilities, and equipment, which will create an undue burden and may lead to an increased possibility for human error. Therefore, SNC commits to use Regulatory Guide 4.15, Revision 1, methodology for Vogtle Units 3 and 4 for optimal consistency, efficiency, and practicality.

11.5.4 Process and Airborne Monitoring and Sampling

Radiation monitors are used to initiate automatic closure of isolation valves and dampers in liquid and gaseous process systems as described in [Subsection 11.5.2.3](#). These radiation monitors address the requirement of General Design Criterion 60 to suitably control the release of radioactive materials in gaseous and liquid effluents. [The sampling program for liquid and gaseous effluents will conform to Regulatory Guide 4.15, Revision 1 \(See Appendix 1A\)](#).

Radiation monitors are used in the radioactive waste processing systems as described in [Subsection 11.5.2.3](#). These radiation monitors address the requirement of General Design Criterion 63 to monitor radiation levels in radioactive waste systems.

Radiation monitors are used in the ventilation systems as described in [Subsection 11.5.2.3](#) to ensure that airborne concentrations within the plant are within the limits of 10 CFR 20.

11.5.4.1 Effluent Sampling

Effluent sampling of potential radioactive liquid and gaseous effluent paths is conducted on a periodic basis to verify effluent processing meets the discharge limits to offsite areas. The effluent sampling program provides the information for the effluent measuring and reporting required by 10 CFR 50.36a and 10 CFR Part 20 and implemented through the Offsite Dose Calculation Manual (ODCM) and plant procedures. The frequency of the periodic sampling and analyses described herein are nominal and may be increased as permitted by procedure. [Tables 11.5-201 and 11.5-202](#) summarize the sample and analysis schedules and sensitivities, respectively. The information contained in [Tables 11.5-201 and 11.5-202](#) are derived from Regulatory Guide 1.21.

Laboratory isotopic analyses are performed on continuous and batch effluent releases in accordance with the ODCM. Results of these analyses are compiled and appropriate portions are utilized to produce the Radioactive Effluent Release Report.

11.5.4.2 Representative Sampling

Representative samples are obtained from well-mixed streams or volumes of effluent liquid through the use of proper sampling equipment, proper location of sampling points, and the development and use of sampling procedures. The recommendations of ANSI N 42.18 ([Reference 203](#)) are considered for the selection of instrumentation specific to the continuous monitoring of radioactivity in liquid effluents.

Sampling of effluent liquids is consistent with guidance in Regulatory Guide 1.21. When practical, effluent releases are batch-controlled, and prior to sampling, large volumes of liquid waste are mixed, in as short a time span as practicable, so that solid particulates are uniformly distributed in the liquid volume. Sampling and analysis is performed, and release conditions set, before release. Sample points are located to minimize flow disturbance due to fittings and other characteristics of equipment and components. Sample lines are flushed consistent with plant procedures to remove sediment deposits.

Representative sampling of process effluents is attained through sample and monitor locations and methods and criteria detailed in plant procedures.

Composite sampling is employed to analyze for hard to measure radionuclides and to monitor effluent streams that normally are not expected to contain significant amounts of radioactive contamination. Composite liquid samples are collected in proportion to the volume of each batch of effluent release. The composite is thoroughly mixed prior to analysis. Collection periods for composites are as short as practicable and periodic checks are performed to identify changes in

composite samples. When grab samples are collected instead of composite samples, the time of the sample, location, and frequency are considered to provide a representative sample of the radioactive materials.

The pressure head of the fluid, if available, is used for taking samples. If sufficient pressure head is not available to take samples, then sample pumps are used to draw the sample from the process fluid to the detector panels and back to the process.

Testing and obtaining representative samples using the radiation monitors described in [Section 11.5](#) will be performed in accordance with ANSI N13.1 ([Reference 201](#)).

For obtaining representative samples in unfiltered ducts, isokinetic probes are tested and used in accordance with ANSI N13.1 ([Reference 201](#)).

Analytical Procedures

Typically, samples of process and effluent gases and liquids are analyzed in the station laboratory or by an outside laboratory via the following techniques:

- Gross alpha/beta counting
- Gamma spectrometry
- Liquid scintillation counting

"Available" instrumentation and counting techniques change as other instruments and techniques become available. For this reason, the frequency of sampling and the analysis of samples are generalized in this subsection.

Gross alpha/beta analysis may be performed directly on unprocessed samples (e.g., air filters) or on processed samples (e.g., evaporated liquid samples). Sample volume, counting geometry, and counting time are chosen to match measurement capability with sample activity. Correction factors for sample-detector geometry, self-absorption and counter resolving time are applied to provide the required accuracy.

Liquid effluent samples are prepared for alpha/beta counting by evaporation onto steel planchets. Gamma analysis may be done on any type of sample (gas, solid or liquid) in a gamma spectrometer.

Tritiated water vapor samples are collected by condensation or adsorption, and the resultant liquid is analyzed by liquid scintillation counting techniques.

Radiochemical separations are used for the routine analysis of Sr-89 and Sr-90.

Liquid samples are collected in polyethylene bottles to minimize absorption of nuclides onto container walls.

11.5.5 Post-Accident Radiation Monitoring

The radiation monitors listed below meet the guidelines of Regulatory Guide 1.97 and are described in [Subsections 11.5.2.3](#) and [11.5.6.2](#). For further Regulatory Guide 1.97 information refer to [Appendix 1A](#) and [Section 7.5](#).

- Main steam line radiation monitors
- Steam generator blowdown radiation monitor

- Main control room supply air duct radiation monitors
- Plant vent radiation monitor
- Turbine island vent discharge radiation monitor
- Containment high range radiation monitors
- Primary sampling room area monitor
- CSA area monitor

The post-accident sampling system is described in [Subsection 9.3.3](#) and is used to obtain samples for onsite laboratory analysis, including radioisotopic analysis, after a postulated accident.

11.5.6 Area Radiation Monitors

The area radiation monitors are provided to supplement the personnel and area radiation survey provisions of the AP1000 health physics program described in [Section 12.5](#) and to comply with the personnel radiation protection guidelines of 10 CFR 20, 10 CFR 50, and 10 CFR 70; and Regulatory Guides 1.97, 8.2, and 8.8.

During refueling operations in containment and the fuel handling area, criticality monitoring functions, as stated in 10 CFR 70.24, are performed by the area radiation monitors in combination with portable bridge monitors.

11.5.6.1 Design Objectives

The design objectives of the area radiation monitors during normal operating plant conditions and anticipated operational occurrences are to:

- Measure the radiation intensities in specific areas of AP1000
- Warn of uncontrolled or inadvertent movement of radioactive material in AP1000
- Provide local and remote indication of ambient gamma radiation and local and remote alarms at key points where substantial changes in radiation flux might be of immediate importance to personnel
- Annunciate and warn of possible equipment malfunctions and leaks in specific areas of AP1000
- Furnish information for radiation surveys
- Minimize the time, effort, and radiation received by operating personnel during routine maintenance and calibration
- Incorporate modular design concepts throughout, to provide easy maintenance

By meeting the above objectives, the radiation monitoring system aids health physics personnel in keeping radiation exposures as-low-as-reasonably-achievable (ALARA).

Locations of area monitor detectors are based on the following criteria:

- Area monitors are located in areas that are normally accessible and where changes in normal plant operating conditions can cause significant increases in exposure rates above those expected for the areas.
- Area monitors are located in areas that are normally or occasionally accessible where significant increases in exposure rates might occur because of operational transients or maintenance activities.
- Area monitors are located to best measure the increase in exposure rates within a specific area and to avoid shielding of the detector by equipment or structural materials.
- In the selection of area monitors, consideration is given to the environmental conditions under which the monitor operates.
- Area monitors are located to provide access so that minimal maintenance equipment is required and to provide an uncluttered area near the detector and local processing electronics to allow for field alignment and calibration.

The area radiation monitors are listed in [Table 11.5-2](#).

11.5.6.2 Post-Accident Area Monitors

The following area monitors are provided to meet Regulatory Guide 1.97 guidelines as discussed in [Appendix 1A](#) and [Section 7.5](#).

Containment High Range Radiation Monitor

The containment high range radiation monitors (PXS-JE-RE160, PXS-JE-RE161, PXS-JE-RE162, and PXS-JE-RE163) measure the radiation from the radioactive gases in the containment atmosphere. The monitors receive safety-related power. The detectors are ion chambers, designed to measure the radiation from the radioactive gases inside the containment in accordance with Regulatory Guide 1.97 and NUREG-0737. The monitors are qualified environmentally and seismically in accordance with the guidelines of Regulatory Guides 1.89 and 1.100, respectively.

The containment high range radiation data are displayed in the main control room. When predetermined setpoints are exceeded, the containment high range radiation monitors provide main control room alarms and signals to the protection and safety monitoring system for containment air filtration isolation and normal residual heat removal system valve closure (refer to [Section 7.3](#) for further details). The containment high range radiation monitors provide data for maintaining a record of the gamma radiation intensities after a postulated accident as a function of time, so that the inventory of radioactive materials in the containment volume can be estimated.

The range and principal isotopes are listed in [Table 11.5-1](#).

The high range radiation detectors are mounted inside the containment on the containment wall in widely separated locations. The locations allow the detectors to be exposed to a significant volume of containment atmosphere without obstruction so that the readouts are representative of the containment atmosphere. The arrangement for a containment high range monitor is shown in [Figure 11.5-2](#).

Primary Sampling Room Area Monitor

The primary sampling station is the location where samples are collected and/or analyzed after a postulated accident. The primary sampling room area radiation monitor (RMS-JE-RE008) is located so that its readout is representative of the radiation to which the operating personnel are exposed. A

local readout, an audible alarm, and visual alarms are provided in the primary sampling room to alert operating personnel to increasing exposure rates. A local readout, an audible alarm, and visual alarms are provided outside of the primary sampling room and are visible to operating personnel prior to entry. Indication and alarms are also provided in the main control room.

The monitor is an extended range monitor that uses a gamma-sensitive ion chamber. The monitor range and principal isotopes are listed in [Table 11.5-2](#).

Control Support Area (CSA) Area Monitor

The control support area is the location from which engineering support will be provided to the operators following a postulated accident. The CSA area radiation monitor (RMS-JE-RE016) is located so that its readout is representative of the radiation to which the support personnel are exposed. A local readout, an audible alarm, and visual alarms are provided locally to alert personnel to increasing exposure rates. A local readout, an audible alarm, and visual alarms are provided outside of the room and are visible to personnel prior to entry. Indication and alarms are also provided in the main control room.

The monitor is a normal range monitor that uses a gamma-sensitive Geiger-Mueller tube. The monitor range and principal isotopes are listed in [Table 11.5-2](#).

11.5.6.3 Normal Range Area Monitors

Normal range area radiation monitors are located in accordance with the location criteria given in [Subsection 11.5.6.1](#). A local readout, an audible alarm, and visual alarms are provided in each monitored area to alert operating personnel to increasing exposure rates. Visual alarms are provided outside of each monitored area so that they are visible to operating personnel prior to entry. Indication and alarms are also provided in the main control room.

The monitor detectors are gamma-sensitive Geiger-Mueller tubes. The monitors and their ranges are listed in [Table 11.5-2](#).

11.5.6.4 Fuel Handling Area Criticality Monitors

Criticality monitoring of the fuel handling and storage areas is performed in accordance with 10 CFR 70.24 by radiation monitors RMS-JE-RE012 and RMS-JE-RE020. The area radiation monitoring is augmented during fuel handling operations by a portable radiation monitor on the machine handling fuel. The fuel handling area radiation monitor parameters are provided in [Table 11.5-2](#).

The permanent criticality monitors are physically separated by a large distance and have overlapping fields of view. Each detector's field of view can detect radiation from a fuel criticality accident in the areas occupied by personnel where fuel is stored and handled. The criticality monitors do not have a direct line of sight in the new fuel storage pit because the arrangement of new fuel prevents accidental criticality. The alarm set points of the radiation monitors are below the sensitivity needed to detect the 10 CFR 70.24 specified 20 rads/minute dose rate in soft tissue of combined gamma and neutron radiation from an unshielded source at two meters distance. A criticality excursion will produce an audible local alarm and an alarm in the plant MCR.

11.5.6.5 Quality Assurance

The quality assurance program for design, fabrication, procurement, and installation of the radiation monitoring system and radiation monitors from other systems is in accordance with the overall quality assurance program described in [Chapter 17](#).

The sampling program and the associated monitors conform to Regulatory Guide 4.15, Revision 1 (See [Appendix 1A](#)).

11.5.7 Preoperational Testing

Confirmation testing on the plant vent will be performed during plant startup to qualify the sample extraction location.

Velocity profile mapping at the sample extraction point will confirm that the velocity profile, including cyclonic flow, does not substantially affect flow mixing or sample nozzle performance, and is acceptable for obtaining a representative sample.

Performance testing with tracer gas and particulates will be performed over normal and selected off-normal flow conditions. Tracer gas and particulates testing will confirm an acceptably representative sample is obtained.

The quantitative test acceptance criteria are dependent on the final design of the sampling system. The acceptance criteria will be established prior to testing and will be defined in the test procedures.

This set of confirmation tests will be performed for the first plant. For subsequent units, either these tests may be performed, or documentation may be used to justify that the plant vent geometry and the effluent flow conditions are the same or similar, and that these test results remain applicable.

11.5.8 Combined License Information

An Offsite Dose Calculation Manual (ODCM) is developed and implemented in accordance with the recommendations and guidance of NEI 07-09A ([Reference 202](#)). The ODCM contains the methodology and parameters used for calculating doses resulting from liquid and gaseous effluents. The ODCM addresses operational setpoints, including planned discharge rates, for radiation monitors and monitoring programs (process and effluent monitoring and environmental monitoring) for the control and assessment of the release of radioactive material to the environment. The ODCM provides the limitations on operation of the radwaste systems, including functional capability of monitoring instruments, concentrations of effluents, sampling, analysis, 10 CFR Part 50, Appendix I dose and dose commitments, and reporting. The ODCM will be finalized prior to fuel load with site-specific information.

[Table 13.4-201](#) provides milestones for ODCM implementation.

The process and effluent monitoring and sampling per ANSI N13.1 and Regulatory Guides 1.21 and 4.15 is addressed in [Subsections 11.5.1.2, 11.5.2.4, 11.5.3, 11.5.4, 11.5.4.1, 11.5.4.2, and 11.5.6.5](#).

The 10 CFR [Part 50](#), Appendix I guidelines for maximally exposed offsite individual doses and population doses via liquid and gaseous effluents are addressed in [Subsections 11.2.3.5 and 11.3.3.4](#) for liquid and gaseous effluents, respectively.

11.5.9 References

201. ANSI N13.1-1969, "Guide to Sampling Airborne Radioactive Materials in Nuclear Facilities."
202. NEI 07-09A, "Generic FSAR Template Guidance for Offsite Dose Calculation Manual (ODCM) Program Description," Revision 0, March 2009 (ML091050234).
203. ANSI N42.18-2004, "Specification and Performance of On-Site Instrumentation for Continuously Monitoring Radioactivity in Effluents."

**Table 11.5-1 (Sheet 1 of 2)
Radiation Monitor Detector Parameters**

Detector	Type	Service	Isotopes	Nominal Range
BDS-JE-RE010	γ	Steam Generator Blowdown Electrodeionization Effluent	Cs-137	1.0E-7 to 1.0E-2 μCi/cc
BDS-JE-RE011	γ	Steam Generator Blowdown Electrodeionization Brine	Cs-137	1.0E-7 to 1.0E-2 μCi/cc
CCS-JE-RE001	γ	Component Cooling Water System	Cs-137	1.0E-7 to 1.0E-2 μCi/cc
VFS-JE-RE101	β	Plant Vent Particulate	Sr-90 Cs-137	1.0E-12 to 1.0E-7 μCi/cc
VFS-JE-RE102	γ	Plant Vent Iodine	I-131	1.0E-11 to 1.0E-6 μCi/cc
VFS-JE-RE103	β	Plant Vent Gas (Normal Range)	Kr-85 Xe-133	1.0E-7 to 1.0E-2 μCi/cc
VFS-JE-RE104A	β/γ	P.V. Extended Range Gas (Accident Mid Range)	Kr-85 Xe-133	1.0E-4 to 1.0E+2 μCi/cc
VFS-JE-RE104B	β/γ	P.V. Extended Range Gas (Accident High Range)	Kr-85 Xe-133	1.0E-1 to 1.0E+5 μCi/cc
PSS-JE-RE026	β	Containment Atmosphere Gas (Note 2)	Kr-85 Xe-133 Ar-41 N-13	1.0E-7 to 1.0E-2 μCi/cc
PSS-JE-RE027	β	Containment Atmosphere beta-sensitive scintillation detector (Note 2)	F18	1.0E-10 to 1.0E-5 μCi/cc
PSS-JE-050	γ	Primary Sampling Liquid	I-131 Cs-137	1.0E-4 to 1.0E+2 μCi/cc
PSS-JE-052	γ	Primary Sampling Gaseous	Kr-85 Xe-133	1.0E-7 to 1.0E-2 μCi/cc
SGS-JE-RE026A	γ	Main Steam Line	Kr, Xe, I	1.0E-1 to 1.0E+3 μCi/cc
SGS-JE-RE026B	γ	Main Steam Line	N-16	30 to 200 gallons per day
SGS-JE-RE027A	γ	Main Steam Line	Kr, Xe, I	1.0E-1 to 1.0E+3 μCi/cc
SGS-JE-RE027B	γ	Main Steam Line	N-16	30 to 200 gallons per day
SWS-JE-RE008	γ	Service Water Blowdown	Cs-137	1.0E-7 to 1.0E-2 μCi/cc
TDS-JE-RE001A/B	β/γ	Turbine Island Vent Discharge (Note 3)	Kr-85 Xe-133	1.0E-6 to 1.0E+5 μCi/cc (Note 4)
VAS-JE-RE001	β	Fuel Handling Area Exhaust (Note 5)	Kr-85 Xe-133	1.0E-7 to 1.0E-2 μCi/cc
VAS-JE-RE002	β	Auxiliary Building Exhaust (Note 5)	Kr-85 Xe-133	1.0E-7 to 1.0E-2 μCi/cc
VAS-JE-RE003	β	Annex Building Exhaust (Note 5)	Kr-85 Xe-133	1.0E-7 to 1.0E-2 μCi/cc

**Table 11.5-1 (Sheet 2 of 2)
Radiation Monitor Detector Parameters**

Detector	Type	Service	Isotopes	Nominal Range
VBS-JE-RE001A	β	Main Control Room Supply Air Duct (Particulate) (Note 1) (Note 5)	Sr-90 Cs-137	1.0E-12 to 1.0E-7 μCi/cc
VBS-JE-RE001B	β	Main Control Room Supply Air Duct (Particulate) (Note 1) (Note 5)	Sr-90 Cs-137	1.0E-12 to 1.0E-7 μCi/cc
VBS-JE-RE002A	γ	MCR Supply Air Duct (Iodine) (Note 1) (Note 5)	I-131	1.0E-11 to 1.0E-5 μCi/cc
VBS-JE-RE002B	γ	MCR Supply Air Duct (Iodine) (Note 1) (Note 5)	I-131	1.0E-11 to 1.0E-5 μCi/cc
VBS-JE-RE003A	β	MCR Supply Air Duct (Gas) (Note 1) (Note 5)	Kr-85 Xe-133	1.0E-7 to 1.0E-1 μCi/cc
VBS-JE-RE003B	β	MCR Supply Air Duct (Gas) (Note 1) (Note 5)	Kr-85 Xe-133	1.0E-7 to 1.0E-1 μCi/cc
VFS-JE-RE001	β	Containment Air Filtration Exhaust (Note 5)	Kr-85 Xe-133	1.0E-7 to 1.0E-2 μCi/cc
VHS-JE-RE001	β	H.P. & Hot Machine Shop Exhaust (Note 5)	Sr-90 Cs-137	1.0E-12 to 1.0E-7 μCi/cc
VRS-JE-RE023	β	Radwaste Building Exhaust (Note 5)	Sr-90 Cs-137	1.0E-12 to 1.0E-7 μCi/cc
WGS-JE-RE017	β	Gaseous Radwaste Discharge	Kr-85 Xe-133	1.0E-4 to 1.0E+2 μCi/cc
WLS-JE-RE229	γ	Liquid Radwaste Discharge	Cs-137	1.0E-6 to 1.0E-1 μCi/cc
WWS-JE-RE021	γ	Waste Water Discharge	Cs-137	1.0E-7 to 1.0E-2 μCi/cc

Notes:

1. Safety-related
2. Seismic Category I
3. The condenser air removal system (CMS) and the gland seal system (GSS) discharge into the turbine island vents, drains and relief system (TDS). The exhaust from the TDS into the turbine island vent is continuously monitored for radiation.
4. Turbine island vent radiation monitor includes two G-M tubes with nominal ranges of 1.0E-6 to 1.0E+0 μCi/cc and 1.0E-1 to 1.0E+5 μCi/cc.
5. Monitor is sensitive enough to detect 10 Derived Air Concentration (DAC)-hours.

**Table 11.5-2
Area Radiation Monitor Detector Parameters**

Detector	Type	Service	Nominal Range
PXS-JE-RE160	Y	Containment High Range (Note 3)	1.0E-0 to 1.0E+7 R/hr
PXS-JE-RE161	Y	Containment High Range (Note 3)	1.0E-0 to 1.0E+7 R/hr
PXS-JE-RE162	Y	Containment High Range (Note 3)	1.0E-0 to 1.0E+7 R/hr
PXS-JE-RE163	Y	Containment High Range (Note 3)	1.0E-0 to 1.0E+7 R/hr
RMS-JE-RE008	Y	Primary Sampling Room	1.0E-1 to 1.0E+7 mR/hr
RMS-JE-RE009	Y	Containment Area Personnel Hatch – Operating Deck – 135'-3" Elevation	1.0E-1 to 1.0E+4 mR/hr (Note 1)
RMS-JE-RE010	Y	Main Control Room	1.0E-1 to 1.0E+4 mR/hr
RMS-JE-RE011	Y	Chemistry Laboratory Area	1.0E-1 to 1.0E+4 mR/hr
RMS-JE-RE012	Y	Fuel Handling Area	1.0E-1 to 1.0E+4 mR/hr (Note 2)
RMS-JE-RE013	Y	Rail Car Bay/Filter Storage Area (Note 4)	1.0E-1 to 1.0E+4 mR/hr
RMS-JE-RE014A	Y	Liquid and Gaseous Radwaste Area 1	1.0E-1 to 1.0E+4 mR/hr
RMS-JE-RE014B	Y	Liquid and Gaseous Radwaste Area 2	1.0E-1 to 1.0E+4 mR/hr
RMS-JE-RE016	Y	CSA Area	1.0E-1 to 1.0E+4 mR/hr
RMS-JE-RE017	Y	Radwaste Bldg. Mobile Systems Facility (Note 4)	1.0E-1 to 1.0E+4 mR/hr
RMS-JE-RE018	Y	Hot Machine Shop	1.0E-1 to 1.0E+4 mR/hr
RMS-JE-RE019	Y	Annex Staging & Storage Area	1.0E-1 to 1.0E+4 mR/hr
RMS-JE-RE020	Y	Fuel Handling Area	1.0E-1 to 1.0E+4 mR/hr (Note 2)
RMS-JE-RE021	Y	Containment Area Personnel Hatch – Maintenance Level – 100'-0" Elevation	1.0E-1 to 1.0E+04 mR/hr (Note 1)

Notes:

1. Radiation levels are monitored by the permanent containment area radiation monitor and by a portable bridge monitor during refueling operations. The containment area radiation monitor is located to best measure the increase in exposure rates for this area and to provide an alarm locally and in the main control room.
2. Radiation levels are monitored by the permanent fuel handling area radiation monitors and by a portable bridge monitor during fuel handling operations. The fuel handling area radiation monitors are located to best measure the increase in exposure rates for this area and to provide an alarm locally and in the main control room.
3. Safety-related
4. Monitors areas used for storage of wet wastes (including processed and packaged spent resins) and dry wastes.

**Table 11.5-201 (Sheet 1 of 2)
Minimum Sampling Frequency**

Stream	Sampled Medium	Frequency
Gaseous	Continuous Release	<p>A sample is taken within one month of initial criticality, and at least weekly thereafter to determine the identity and quantity for principal nuclides being released. A similar analysis of samples is performed following each refueling, process change, or other occurrence that could alter the mixture of radionuclides.</p> <p>When continuous monitoring shows an unexplained variance from an established norm.</p> <p>Monthly for tritium.</p>
	Batch Release	<p>Prior to release to determine the identity and quantity of the principal radionuclides (including tritium).</p>
	Filters (particulates)	<p>Weekly.</p> <p>Quarterly for Sr-89 and Sr-90.</p> <p>Monthly for gross alpha.</p>

**Table 11.5-201 (Sheet 2 of 2)
Minimum Sampling Frequency**

Stream	Sampled Medium	Frequency
Liquid	Continuous Releases	<p>Weekly for principal gamma-emitting radionuclides.</p> <p>Monthly, a composite sample for tritium and gross alpha.</p> <p>Monthly, a representative sample for dissolved and entrained fission and activation gases.</p> <p>Quarterly, a composite sample for Sr-89, Sr-90, and Fe-55.</p>
	Batch Releases	<p>Prior to release for principal gamma-emitting radionuclides.</p> <p>Monthly, a composite sample for tritium and gross alpha.</p> <p>Monthly, a representative sample from at least one representative batch for dissolved and entrained fission and activation gases.</p> <p>Quarterly, a composite sample for Sr-89, Sr-90 and Fe-55.</p>

**Table 11.5-202
Minimum Sensitivities**

Stream	Nuclide	Sensitivity
Gaseous	Fission & Activation Gases	1.0E-04 $\mu\text{Ci/cc}$
	Tritium	1.0E-06 $\mu\text{Ci/cc}$
	Iodines & Particulates	Sufficient to permit measurement of a small fraction of the activity that would result in annual exposures of 15 mrem to thyroid for iodines, and 15 mrem to any organ for particulates, to an individual in an unrestricted area.
	Gross Radioactivity	Sufficient to permit measurement of a small fraction of the activity that would result in annual air dose of 1) 10 mrad due to gamma, and 2) 20 mrad of beta at any location near ground level at or beyond the site boundary.
Liquid	Gross Radioactivity	1.0E-07 $\mu\text{Ci/ml}$
	Gamma-emitters	5.0E-07 $\mu\text{Ci/ml}$
	Dissolved & Entrained Gases	1.0E-05 $\mu\text{Ci/ml}$
	Gross Alpha	1.0E-07 $\mu\text{Ci/ml}$
	Tritium	1.0E-05 $\mu\text{Ci/ml}$
	Sr-89 & Sr-90	5.0E-08 $\mu\text{Ci/ml}$
	Fe-55	1.0E-06 $\mu\text{Ci/ml}$

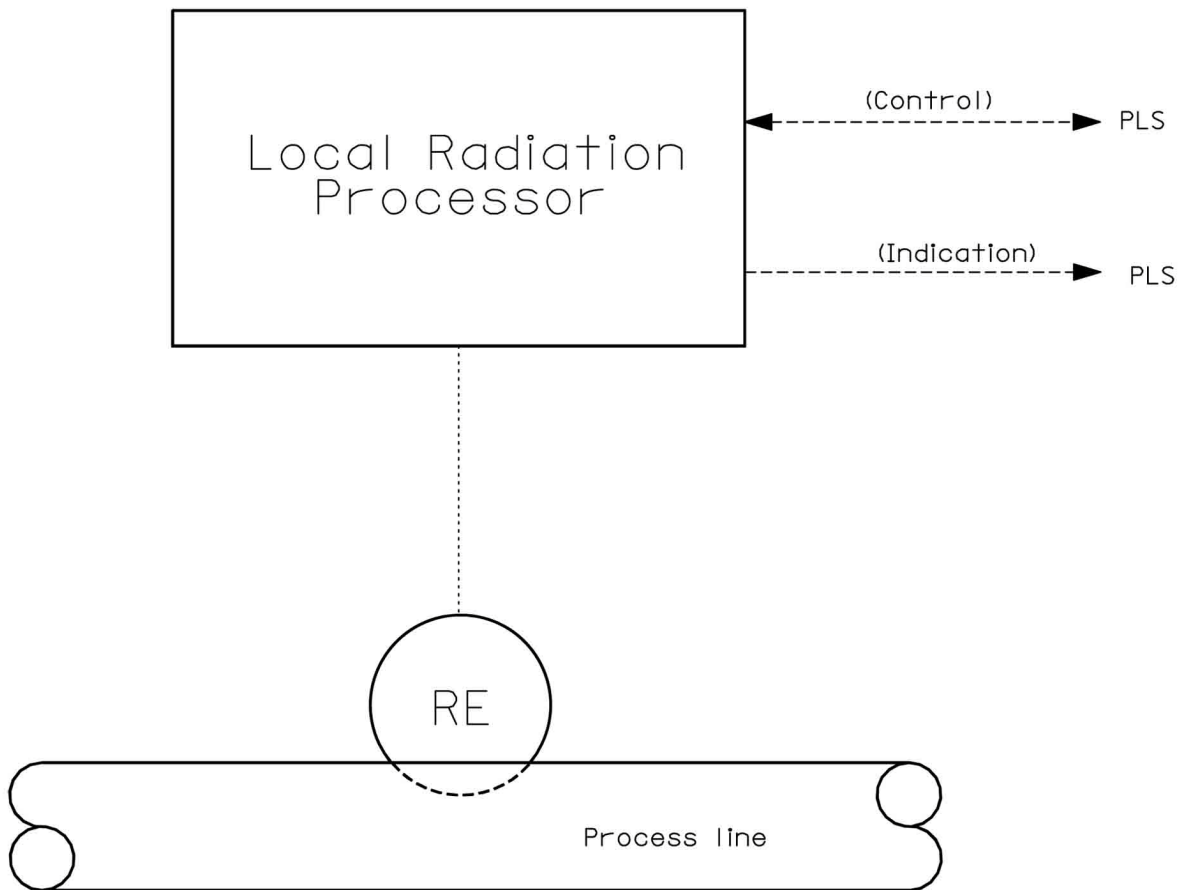

Figure 11.5-1
Process In-Line Radiation Monitor

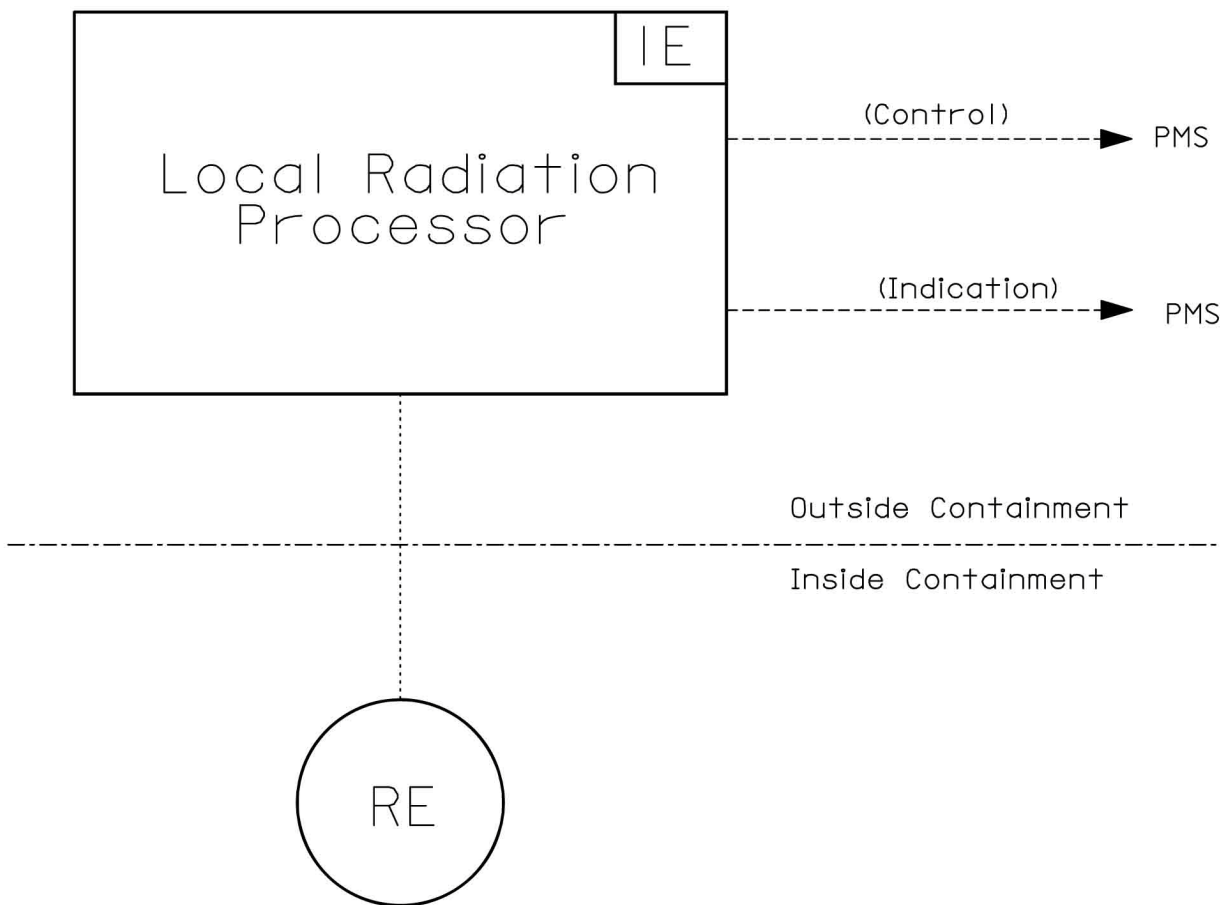

Figure 11.5-2
Safety-Related Containment High Range Radiation Monitor

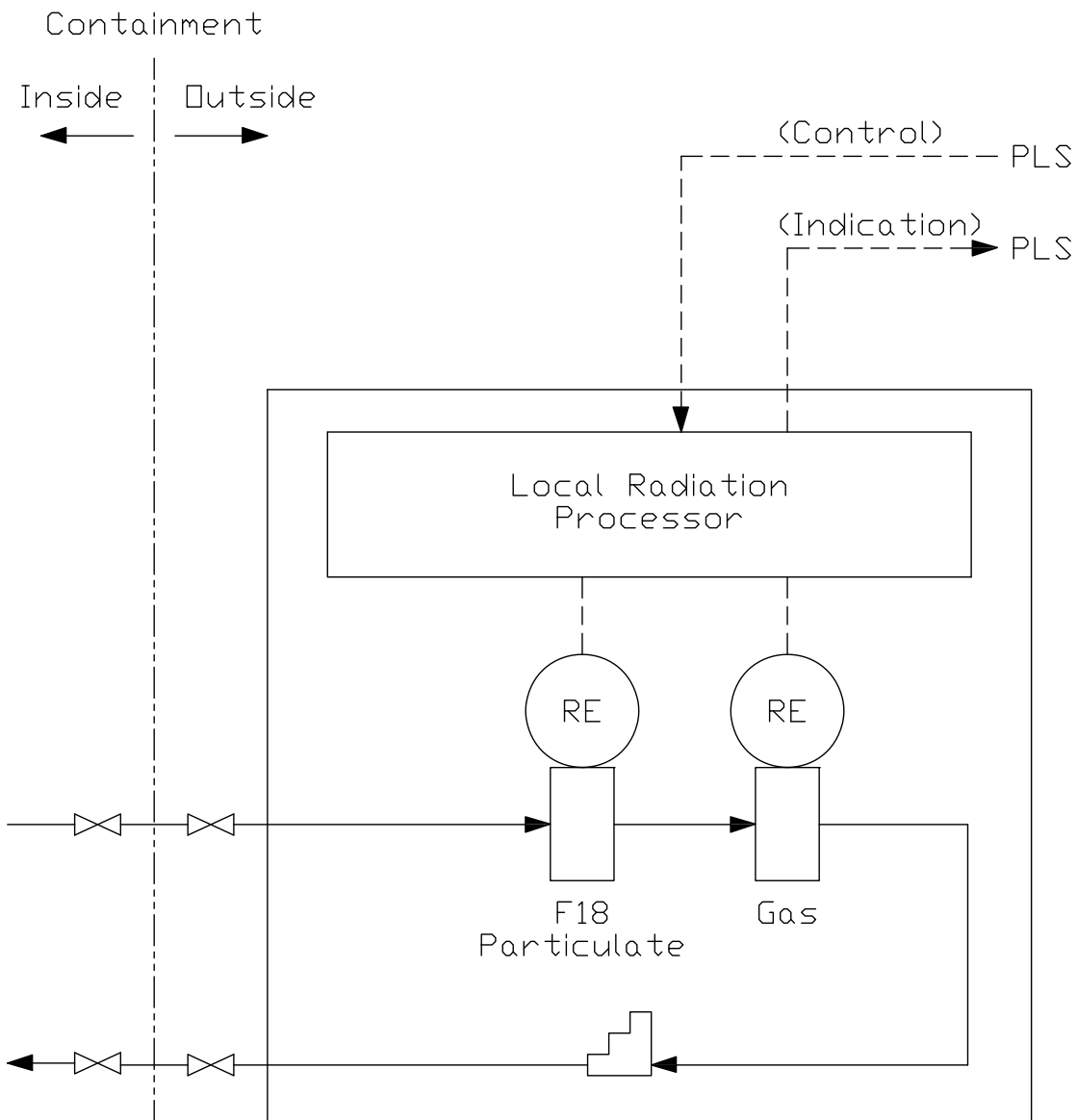
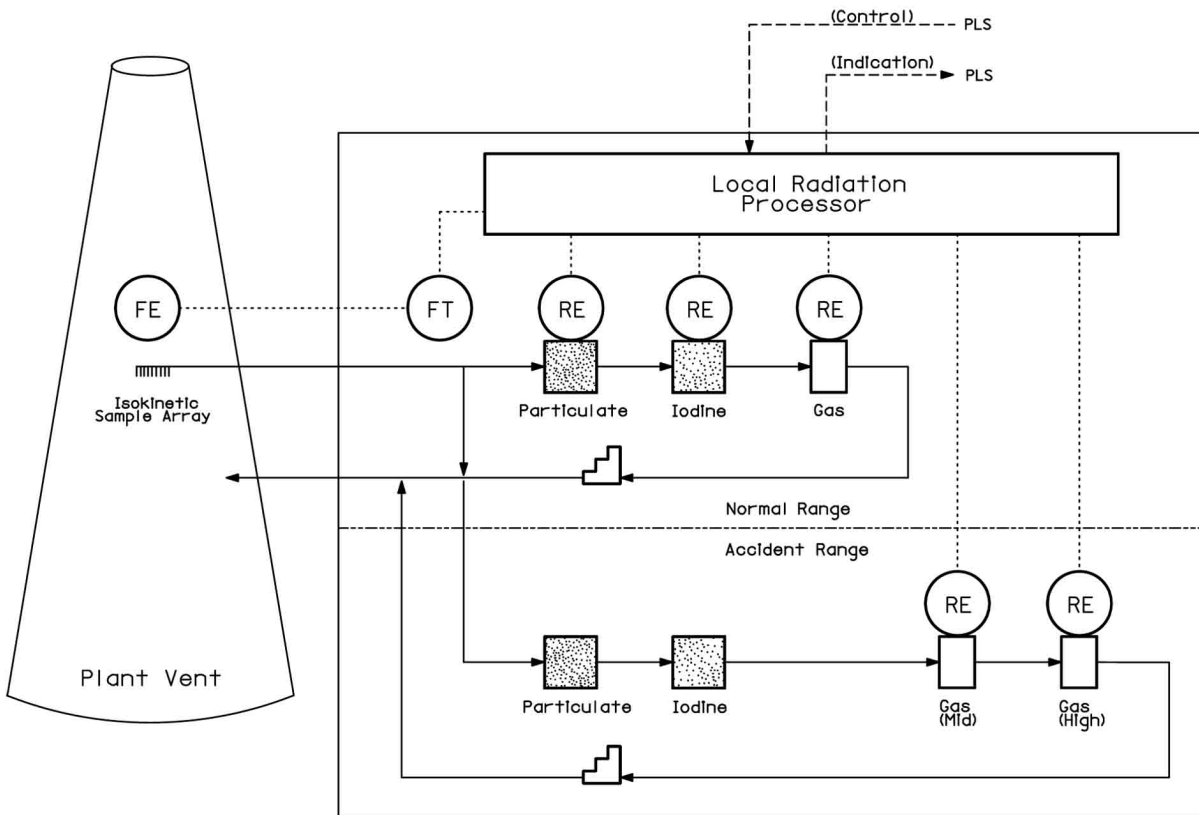

Figure 11.5-3
Containment Atmosphere Radiation Monitor



**Figure 11.5-4
Plant Vent Radiation Monitor**

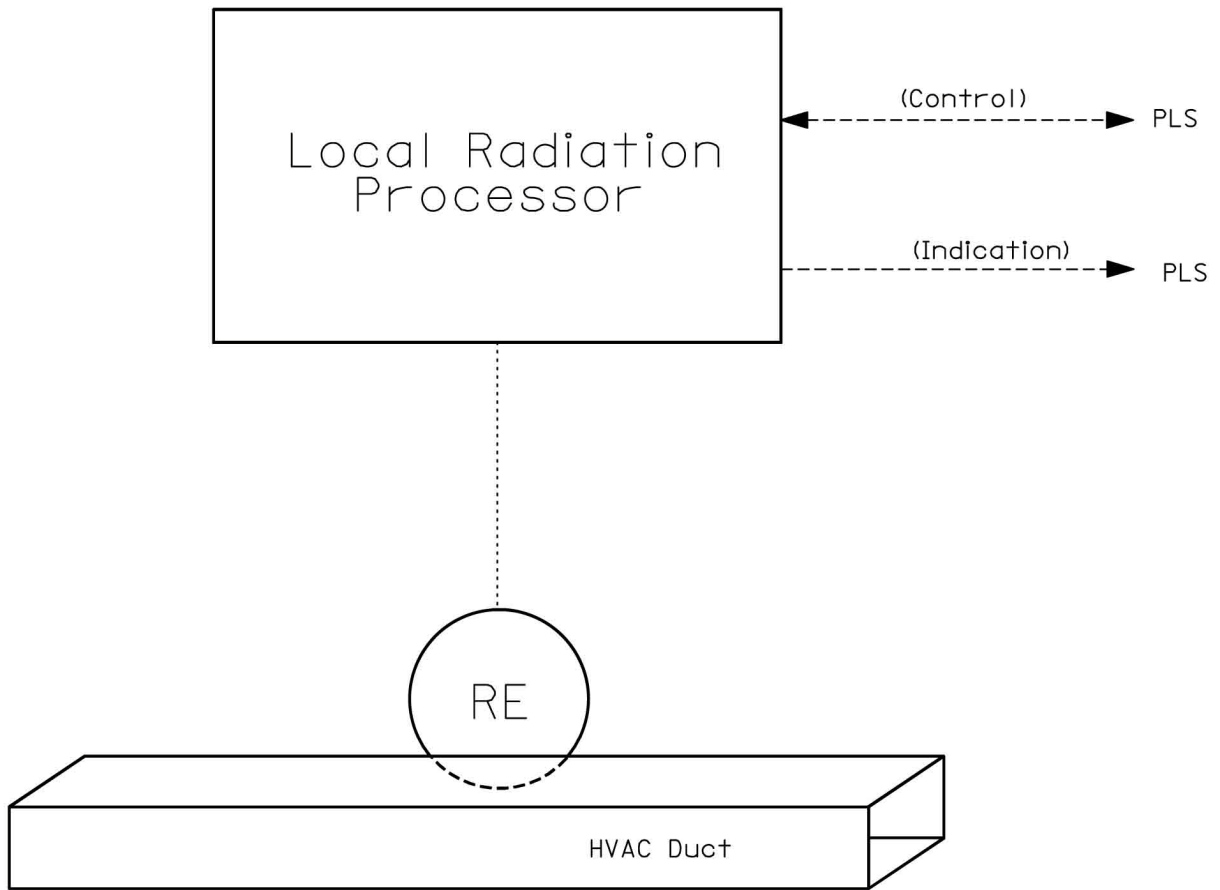

Figure 11.5-5
In-Line HVAC Duct Radiation Monitor

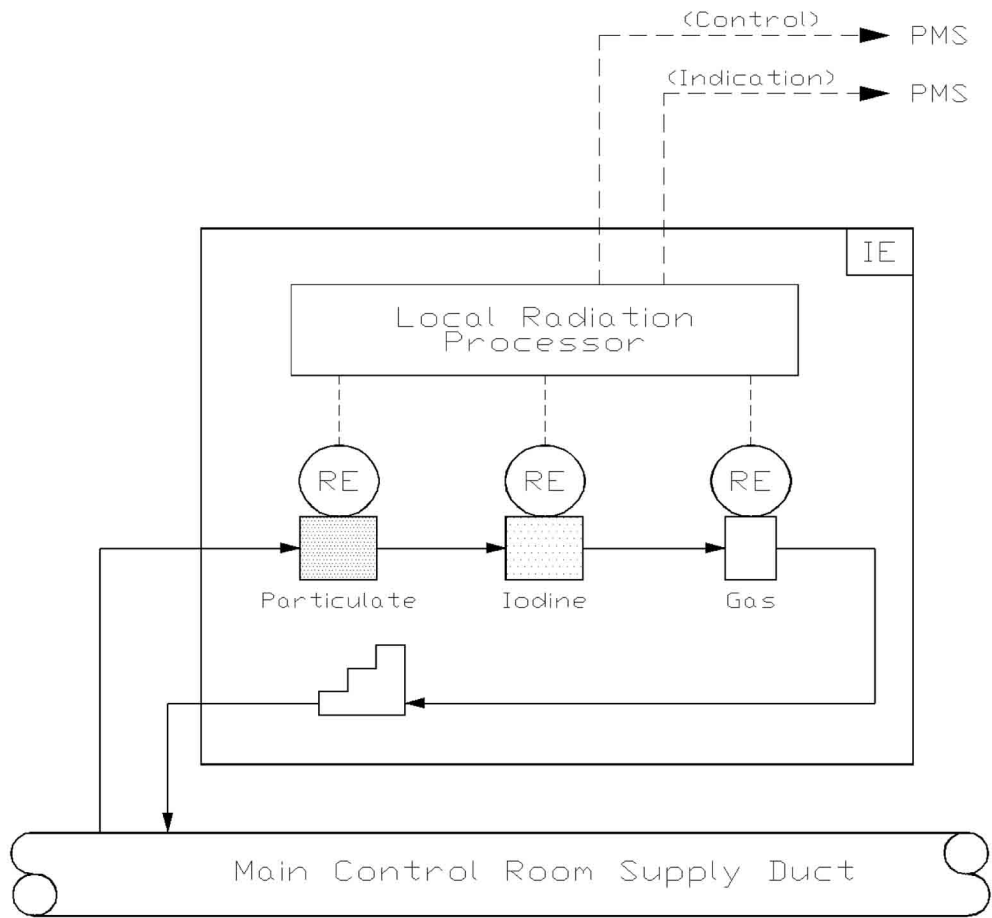

Figure 11.5-6
Safety-Related Main Control Room Supply Duct Radiation Monitor

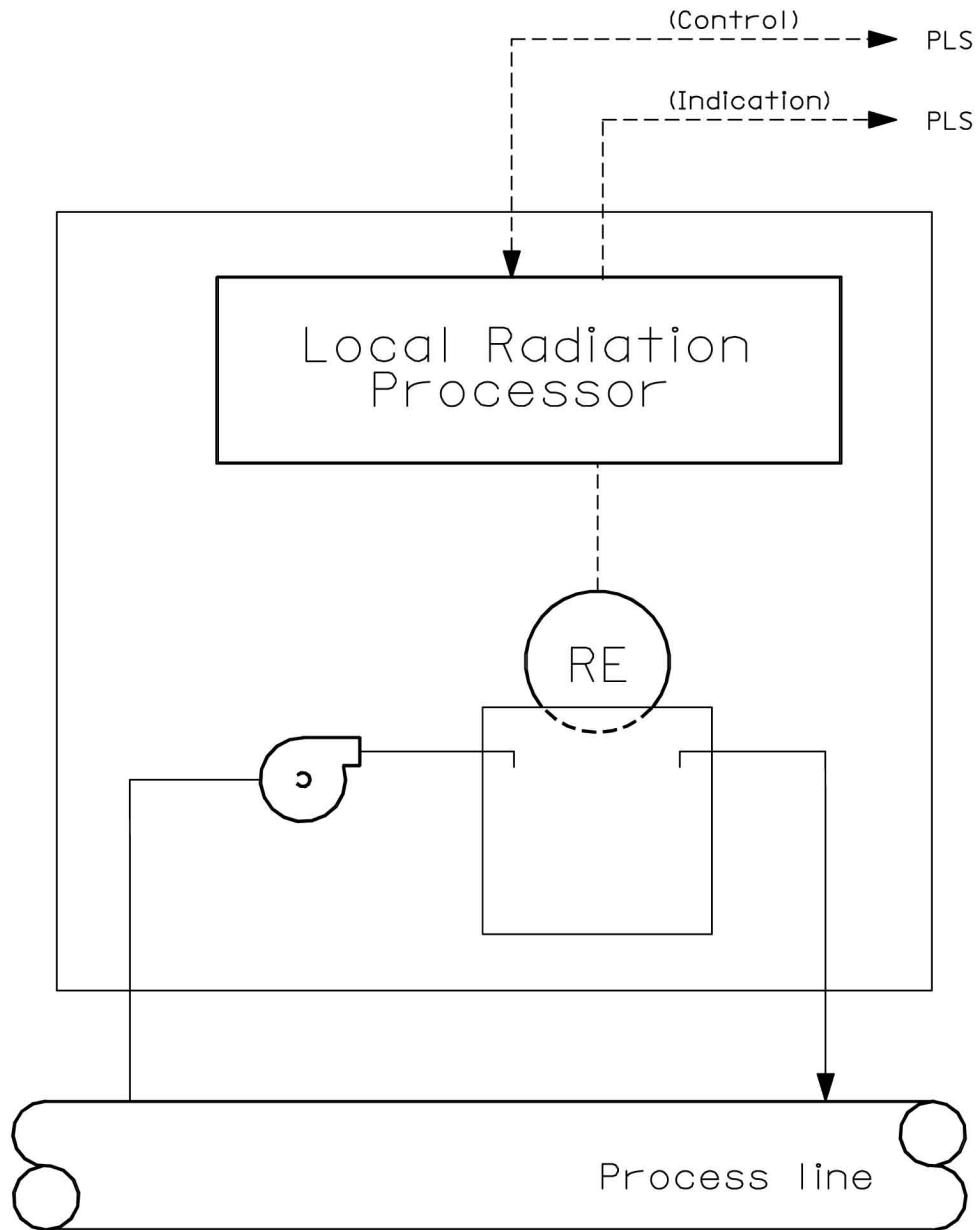

Figure 11.5-7
Liquid Offline Radiation Monitor

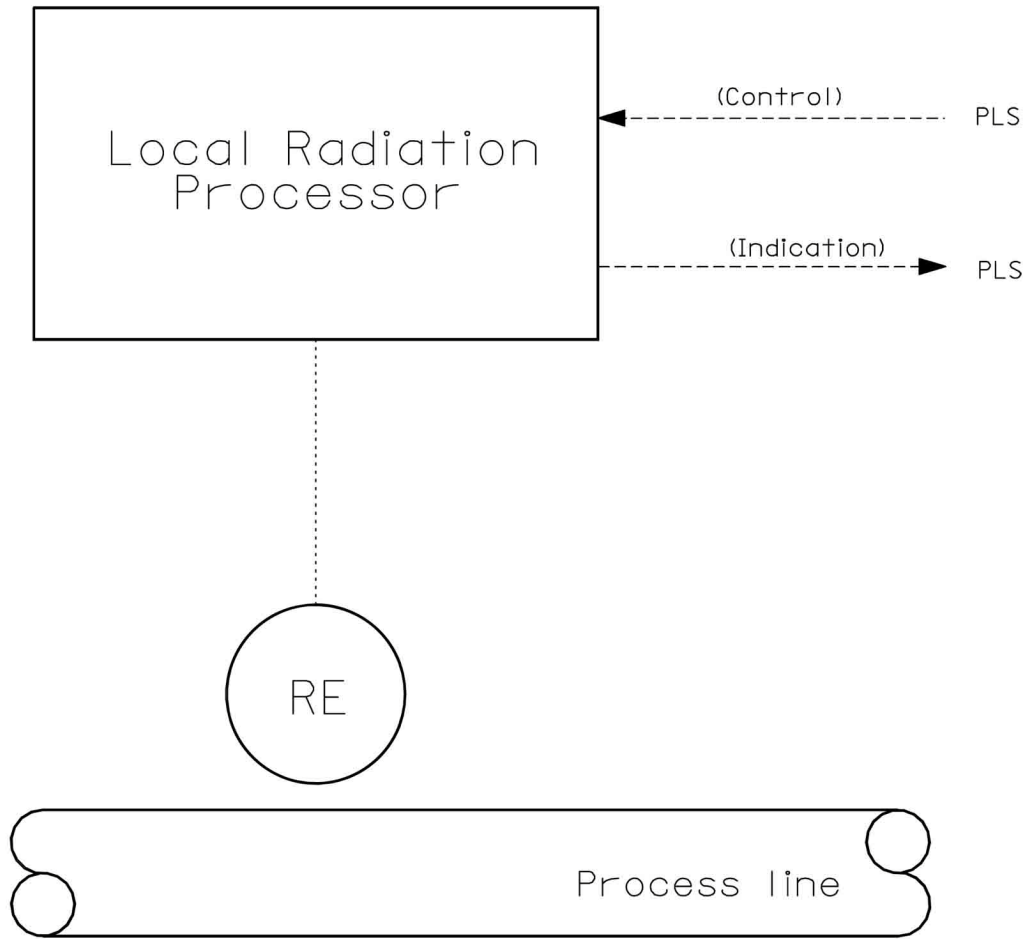

Figure 11.5-8
Adjacent to Line Radiation Monitor

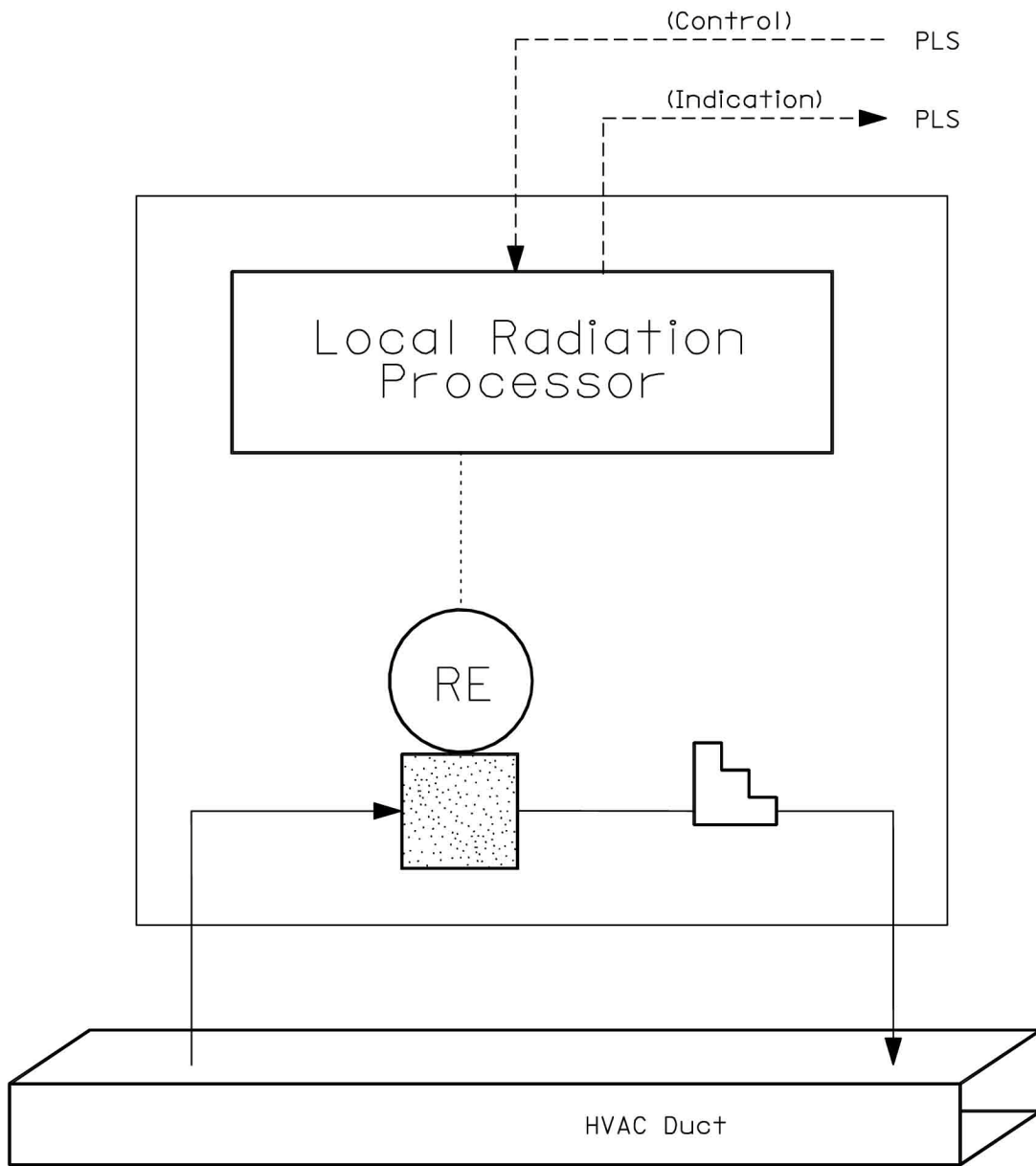

Figure 11.5-9
HVAC Duct Particulate Radiation Monitor