

15.0 Transient and Accident Analyses

The evaluation of the safety of a nuclear power plant requires analyses of the response of the plant to postulated equipment failures or malfunctions. These analyses help to determine the limiting conditions for operation (LCO), limiting safety system settings (LSSS), and design specifications for safety-related components and systems to protect public health and safety. To confirm that the plant transient and accident analyses represent a sufficiently broad spectrum of initiating events, the transients and accidents are categorized according to type and frequency.

15.0.0.1 Classification of Transients and Accidents

The classification of initiating events is defined by their effect on the RCS. They are categorized according to their expected frequency of occurrence, which provides a basis for selection of the applicable analysis acceptance criteria for each initiating event. Each initiating event is categorized as an anticipated operational occurrence (AOO), a postulated accident (PA), or a beyond design basis event. AOOs, as defined in Appendix A to 10 CFR 50, are those conditions of normal operation that are expected to occur one or more times during the life of the nuclear plant unit. The Standard Review Plan (SRP) presented in NUREG-0800 (Reference 1) refers to AOOs as incidents of moderate frequency (i.e., events that are expected to occur several times during the plant's lifetime) and infrequent events (i.e., events that may occur during the lifetime of the plant). PAs are unanticipated occurrences; they are postulated to occur but not expected to occur during the life of the nuclear plant unit.

AOOs and PAs for the U.S. EPR fall into one of the following event types:

- Radioactive release from a subsystem or component.
- Increase in heat removal by the secondary system.
- Decrease in heat removal by the secondary system.
- Decrease in RCS flow rate.
- Reactivity and power distribution anomaly.
- Increase in RCS inventory.
- Decrease in RCS inventory.

For the U.S. EPR, the range of events considered in the safety analysis is developed by considering potential failures in plant systems or operator errors for each initiating event type as defined above. The resulting initiating events are further categorized as either an AOO or PA, depending on expected frequency of occurrence.

Table 15.0-1—U.S. EPR Initiating Events provides a list of initiating events analyzed for the U.S. EPR, along with the frequency and type categorization for the event.

15.0.0.2 Accident Analysis Acceptance Criteria

The objective of the accident analyses is to evaluate the ability of the plant to operate without undue hazard to the health and safety of the public. Plant systems such as the distributed control system (DCS) and engineered safety features (ESF) systems are designed to mitigate the consequences of postulated upset conditions (transients and accidents). In conjunction with how the plant is operated, these systems help to prevent or limit the release of radioactive material to protect the health and safety of the public.

The integrity of one or more of three barriers (the fuel cladding, the reactor coolant pressure boundary, and the containment system) prevents or limits the release of radioactivity. These barriers act in series to prevent or limit the release of radioactive material outside the plant during postulated upset conditions. The barriers are linked to the frequency of occurrence of the postulated event so that for the higher frequency events, the integrity of the three barriers is maintained. For the extremely low frequency events, the first two barriers may be breached with the final barrier (containment) limiting the release. See Section 15.0.0.1 for a description of event classification.

Plant operation is controlled through a set of LCOs, or restraints that define the allowed operating domain. The accident analysis uses these LCOs as initial conditions for each of the postulated events analyzed. The requirements of the DCS and ESF are established as LSSs by the accident analysis results to confirm that the integrity of the various barriers is maintained to protect the public. Therefore, the allowed operating space, the design of plant safety systems, and the type and likelihood of postulated events are used to demonstrate that a given plant design protects the health and safety of the public. The analysis acceptance criteria consider challenges to the three physical barriers and the frequency of occurrence of the postulated events.

Table 15.0-2—Accident Analysis Acceptance Criteria provides the acceptance criteria for AOs and PAs.

15.0.0.3 Plant Characteristics Considered in the Safety Analysis

15.0.0.3.1 Design Plant Conditions and Initial Conditions

The complete operating domain is considered, from power operation to cold shutdown. The U.S. EPR operating modes are shown in Table 15.0-3—Plant Operating Modes. Postulated events are assumed to be initiated from any of the identified operating modes. For most events, however, the limiting cases are initiated from Modes 1 and 2. Both loss of offsite power (LOOP) and offsite-power-available conditions are considered for each event.

The maximum power levels assumed in the accident analyses are described in Table 15.0-4—Nuclear Steam Supply System Power Levels Assumed in the Accident Analysis. This table includes values for the maximum thermal power of the nuclear steam supply system (NSSS), the rated core thermal power, and the energy generated by the reactor coolant pumps (RCPs). A heat balance measurement uncertainty of ± 22 MWt (approximately one-half percent of rated thermal power) is applicable to the core power. The core power is determined using a secondary-side heat balance. The relatively low heat balance uncertainty is achieved by using an ultrasonic flow meter for the feedwater flow rate. Table 15.0-5—Plant Parameters Used in Accident Analyses lists the nominal plant parameters for the accident analyses. Uncertainties in initial plant conditions are applied in accordance with the applicable approved methodologies.

The following uncertainties are considered in establishing the initial conditions:

- Core power: ± 22 MWt (approximately one-half percent of rated thermal power).
- Pressurizer pressure: ± 50 psi (25 psi uncertainty and 25 psi deadband).
- Pressurizer liquid level: ± 5 percent of span (combination of uncertainty and control band).
- Core average temperature: $\pm 4^\circ\text{F}$ (3°F uncertainty and 1°F control band).

Average RCS coolant temperature is a function of core power level (refer to Figure 4.4-7—Average RCS Temperature vs. Core Power). In addition, average temperature can be reduced up to 10°F to accommodate an end-of-cycle (EOC) full power coastdown. A thermal design flow of 119,692 gpm per loop is used in the accident analysis for the RCS response. This thermal design flow is the minimum allowed by plant TSs. The analyses bound up to five percent SG tube plugging.

Table 15.0-6—Reactivity Coefficients, Scram Reactivity, and Computer Codes summarizes information for the analysis of postulated events. This table provides the reactivity coefficients assumed in each event scenario. During the transient, the reactivity contributions from moderator and fuel temperature changes are influenced by the fuel pellet-to-cladding heat transfer coefficient (hgap). For fast transients, such as rod withdrawals from low power or subcritical, where the fuel temperature feedback limits the peak power, a conservatively high hgap is assumed. For departure from nucleate boiling ratio (DNBR) related events a high hgap is also conservative because it maximizes fuel rod surface heat flux. The exception to this is the loss of flow event. For the loss of flow event, sensitivity studies show that a low hgap results in a lower MDNBR because the lower hgap keeps the heat flux higher later in the transient when the RCS flow decreases. In the presence of a zero moderator temperature coefficient, other heatup transients (i.e., turbine trip, loss of normal feedwater, etc.) a high hgap is conservative since it minimizes reactivity feedback from fuel temperature

increases. Thus, the non-LOCA transient analysis uses a high hgap in all cases except loss of flow events, where sensitivity analysis has demonstrated that a low hgap is more conservative. The hgap values are based on COPERNIC (see Section 15.0.0.3.3) and are generated considering a range of fuel management schemes. For LOCAs, the hgap values used are based on RODEX2 and RODEX3 for small and large breaks, consistent with the methodologies described in References 3 and 4.

Additional specific information for each event is presented in the respective Chapter 15 section for the postulated event.

Events are analyzed until the plant achieves a stable, controlled condition, i.e., the reactor is subcritical and remains subcritical, the core is covered, decay heat is being removed from the RCS, and secondary inventory levels are sufficient to maintain RCS temperatures.

The analyses also consider flow capacities of systems such as makeup and relief systems and are biased to make the event in question more severe. For example, for overpressure events, the safety valve flow capacity is based on the rated flow that the valve manufacturer provides. On the other hand, when evaluating the inadvertent opening of a safety valve, the flow is conservatively increased by twenty percent. Similarly, operation with a feedwater heater string out of service is considered for overcooling events, which reduces the initial feedwater temperature at each power level. A lower feedwater temperature is potentially more severe for overcooling events.

The transient and accident analysis results presented in subsequent sections of Chapter 15 represent the limiting cases with respect to the pertinent acceptance criteria for each event. Each transient and accident analyzed has been assessed against the criteria identified in Table 15.0-2 for AOOs and PAs. Generally, one criterion dominates for a given transient or accident. In those cases where more than one criterion could be challenged, each applicable criterion is specifically analyzed.

The limiting cases for each event are summarized in Table 15.0-62—Transient Analysis Limiting Cases, along with the acceptance criteria evaluated. The limiting cases were derived from a spectrum of cases that reflect the range of possible allowed operating conditions (including shutdown modes), availability of offsite power, variation of event-specific parameters (e.g., break size), and possible single failures. Table 15.0-63—Transient Analysis Limiting Case Conditions summarizes the limiting conditions associated with each limiting case. Further discussion of the technical bases for the parameter and single failure selection is provided in each transient and accident section. A more general discussion on single failure is provided in Section 15.0.0.3.8

15.0.0.3.2 Power Distribution

The power distributions considered in thermal margin calculations encompass the spectrum of postulated power distributions, as described in Section 4.3.3. The self-powered neutron detectors provide continuous monitoring of the core 3D power distributions and inherent uncertainties in these measurements are factored into the development of appropriate incore trip setpoints. Therefore, establishment of design power peaking limits is unnecessary for the evaluation of thermal margins. The power distributions are generated and used within the transient setpoint analysis methodology as described in Incore Trip Setpoint and Transient Methodology for the U.S. EPR (Reference 2).

Because of the nature of the U.S. EPR incore setpoint system, i.e., low DNBR reactor trips, traditional plots of DNBR versus time are not meaningful. The nature of the system is that given a transient event, every potential 3D power distribution causes a different evolution of DNBR with time due to the dependency of DNBR on the power distribution. Therefore, any event that can terminate with a Low DNBR trip has an infinite number of DNBR versus time plots.

All transient events that present a challenge to the DNBR specified acceptable fuel design limit (SAFDL) and are sufficiently slow to be resolved by the DNBR algorithm in the setpoint system cause a plant trip once the monitored DNBR reaches the DNBR trip threshold. Therefore, any combination of event and 3D power distribution terminated by a DNBR trip produces a real minimum DNBR at or just above the DNBR design limit. The amount of margin inherent in the transient event is defined by the excess margin provided for in the analysis of the uncertainties used to establish the DNBR setpoint thresholds. All Chapter 15 events protected by a DNBR trip therefore have the same minimum DNBRs and same inherent margin to the design limits. Therefore the basis for showing protection to the DNB SAFDLs relies on determination of appropriate setpoints and verification of the dynamic compensation effects relevant to the plant sensor and I&C architecture. Reference 2 provides details on setpoint determination and verification.

For transient events that challenge the DNBR SAFDL and are too fast to be resolved by the DNBR algorithm, sufficient DNBR margin must be reserved at transient initiation to provide time for other plant trips to intercede and provide the needed protection. The DNBR limiting condition for operation (LCO) is established based on a combination of inherent system uncertainties and the results of the worst case transient DNBR degradation for those transients that are not protected by a Low DNBR trip. Therefore, the basis for showing protection to the DNBR SAFDLs relies on determining the transient event, not protected by a Low DNBR trip, which exhibits the maximum degradation in DNBR prior to some other plant trip interceding and terminating the event.

15.0.0.3.3 Reactivity Coefficients Assumed in the Accident Analysis

The transient response of the NSSS depends on reactivity feedbacks, in particular, the moderator temperature and fuel (Doppler) temperature coefficients. For the U.S. EPR accident analysis, values are chosen to include the expected ranges for a variety of potential operating cycles. The bounding values used in the accident analysis are as follows:

- Moderator temperature coefficient: 5.73 pcm/°F to -50 pcm/°F.
- Doppler coefficient: -1.17 pcm/°F to -1.85 pcm/°F.

The range of coefficients given above cover plant operation between the minimum temperature for criticality and full power and are selected to obtain a conservative response.

Depending on the transient under evaluation, a conservative reactivity coefficient may either be the largest possible value or the smallest possible value. The coefficients are chosen to provide the most adverse response in the core for the transient under consideration. When it is not obvious whether a large or small value is more limiting for a given event, a range is evaluated to produce the most limiting response. The specific values assumed in each analysis are given in Table 15.0-6.

The major computer codes used for each postulated event are also given in Table 15.0-6. Additional codes are used to establish the initial fuel rod conditions. These include COPENIC for non-loss of coolant accident (NON-LOCA), RODEX2 for small-break LOCA, and RODEX3 for large-break LOCA. These codes are described in the Codes and Methods Applicability Report for the U.S. EPR (Reference 3) and the U.S. EPR Realistic Large Break Loss of Coolant Accident (Reference 4).

15.0.0.3.4 Rod Cluster Control Assembly Insertion Characteristics

Following a reactor trip (RT), the position and worth of the rod cluster control assemblies (RCCAs) is important in determining the reduction in reactor power from the time of RT. The negative reactivity insertion produced by the dropping of RCCAs following an RT is determined from the rod worth, the rod position within the core, and the acceleration of the rods into the core. For the accident analyses, the critical time for rod insertion is the drop time, which is the time from when the gripper coils release the rods until the time when the rods are fully inserted. For the U.S. EPR design, the accident analysis assumes a drop time of 3.5 seconds. For most of the postulated events analyzed, the results are not sensitive to the drop time as long as the rods are inserted and the reactor is shut down. However, for events such as the loss of flow and rod ejection, the drop time is critical and has a significant impact on the results. The drop time is specified in the plant TSs and is verified by drop-time testing.

Figure 15.0-1—RCCA Position as a Function of Time to Reach for Full Insertion illustrates normalized RCCA position within the core following gripper coils release, scaled to the 3.5 -second drop time. Figure 15.0-2—Normalized RCCA Rod Worth as a Function of Position Within the Core shows the negative reactivity worth for rod position within the reactor core following RT. The shape of the negative reactivity worth curve results from the conservative assumption that the axial power distribution is skewed to the lower portion of the reactor core. This skewed power distribution is representative of an unbalanced xenon distribution. Figure 15.0-2 is used to calculate the negative reactivity insertion versus time following an RT to point-kinetics core models needed in the respective transient analyses.

Figure 15.0-3—Normalized RCCA Reactivity Worth as a Function of Rod Drop Time is a combination of Figure 15.0-1 and Figure 15.0-2, and it shows the normalized RCCA reactivity worth as a function of time after initiation of rod drop. For the transient analyses, the total negative reactivity insertion of 6161 pcm from full power is assumed unless otherwise noted. The total negative reactivity inserted excludes the reactivity of the most reactive rod that is assumed to be stuck out of the core. The curves in Figure 15.0-3 are only used when a point-kinetics core model is used. When more detailed analyses require three-dimensional or axial one-dimensional core models, a reactor kinetics code is used to calculate the negative reactivity from an RT. For these special cases, the curve from Figure 15.0-1 is used to provide rod position within the core.

Figure 15.0-2 and Figure 15.0-3 contain two curves labeled “conservative” and “LOCF” (loss of coolant flow). Both curves are generated with the PRISM code. The LOCF curve is generated with Doppler feedback and is used for the loss of flow events. The conservative curve is generated without Doppler feedback and is used for other events.

15.0.0.3.5 Assumed Protection and Safety Systems Actions

Table 15.0-7—Reactor Trip Setpoints and Delays Used in the Accident Analysis and Table 15.0-8—Engineered Safety Features Actuation System (ESFAS) Functions Used in the Accident Analysis list the safety-classified protection and safety systems credited in the accident analyses. Additionally, the setpoint and associated uncertainty values for the setpoint and time delays are provided in these tables. Each RT also results in a turbine trip (TT).

Table 15.0-9—Pressurizer and Secondary Safety Relief Valve Settings Used in the Accident Analysis provides pressurizer and secondary relief valve information for valves credited in the accident analysis. This table provides the setpoints, uncertainties, and capacities assumed in the accident analysis.

To maneuver the plant through the various operating modes, from power operation to cold shutdown, permissives are used that activate or inhibit certain functions in the

DCS. These permissives and their setpoints are described in Chapter 7. The availability of plant equipment in each mode is considered in the accident analysis.

15.0.0.3.6 Plant Systems and Components Available for Mitigation of Accident Effects

The plant systems and components that mitigate postulated events in the accident analyses are provided in Table 15.0-10—Plant Systems Used in the Accident Analysis. Safety-related systems are credited to mitigate events in the design-basis accident analyses for the U.S. EPR. These systems are subject to single failure criteria as described in Section 15.0.0.3.8. Non-safety-related systems, including control systems, are simulated when their operation makes the response of the event more severe. In this case, it is assumed that they function as designed. Failures of the non-safety-related systems are considered only as event initiators. A TT is generated by checkback signal on an RT. This signal closes the turbine control and stop valves, terminating steam flow to the turbine. This function is highly reliable and tested on a periodic basis. Crediting these non-safety-related backup PSs and components in the design-basis accident analysis following an RT is consistent with the regulatory position stated in NUREG-0138 (Reference 5).

15.0.0.3.7 Operator Actions

Operator action is credited in certain analyses to mitigate postulated events. In such cases, the action is not credited in the analysis before 30 minutes after event initiation if the action can be performed from the Main Control Room (MCR) and 60 minutes if it cannot be performed from the MCR. In addition, operator errors are considered in developing event initiators and in considering limiting single failures (see Section 15.0.0.3.8 for a more detailed description). The specific operator actions credited in Chapter 15 accident analyses are as follows:

- Following a feedwater line break (FWLB), the operator is credited to trip two RCPs and redirect the emergency feedwater (EFW) train feeding the affected steam generator (SG) to an intact SG.
- For small main steam line breaks (MSLBs) and FWLBs, the operator is credited with closing the main steam isolation valves (MSIVs) when operating below permissive P12, where the low SG pressure MSIV closure signal is disabled. The small main steam line (MSL) breaks do not actuate the low SG ΔP MSIV closure signal.
- Following MSLBs, the operator terminates EFW in the affected SG.
- For the EBS malfunction event, the operator is credited in terminating the event by either opening letdown or terminating EBS.
- For the radiological analysis of the failure of small lines carrying primary coolant outside the reactor building (Section 15.0.3.5), operator action is credited to isolate the failed line.

- For SG tube rupture (SGTR) event, the operator is credited to perform the following actions:
 - Trip the reactor when the chemical and volume control system (CVCS) is operating.
 - Reset the main steam relief train (MSRT) setpoints high on affected SG and, if necessary, initiate the partial cooldown in the unaffected SGs.
 - Close the MSIV on the affected SG.
 - Close the main feedwater (MFW) isolation valve on the affected SG.
 - Isolate the EFW to the affected SG.
 - Initiate and later manage the medium head safety injection (MHSI) pump.
 - Use the pressurizer safety relief valves (PSRVs) to depressurize the RCS.

Once the plant is in a stable, controlled state, the following additional operator actions are required to bring the plant to RHR entry conditions or establish long term cooling for SGTR:

- Actuate the EBS to add boron to the RCS to maintain subcriticality.
- Extend the partial cooldown of the unaffected SGs and depressurize the RCS.
- In the event of a loss of offsite power and loss of all RCPs, use the SG transfer lines to depressurize the affected SG and cool the affected RCS stagnated loop. This allows RHR entry conditions to be met throughout the RCS.

Once the plant is in a stable, controlled state, the following additional operator actions are required to bring the plant to RHR entry conditions or establish long term cooling for LOCAs:

- Use the MSRTs to depressurize the SGs to cool down the RCS.
- Use the EBS to add boron to the RCS to maintain subcriticality.
- Use the PSRVs to depressurize the RCS.
- Once the RCS reaches the conditions for RHR entry, the operator initiates RHR operation.
- For the LOCAs that are too large for the SI systems to refill the RCS, the operator must redirect half of the LHSI flow to the respective hot legs to prevent boron precipitation.

15.0.0.3.8 Limiting Single Failures

The accident analyses presented in Chapter 15 incorporate the most limiting active single failure of a safety-related system. Table 15.0-11—Single Failures Assumed in the Accident Analysis lists the most limiting single failure for each event.

Table 15.0-11 also provides the justification for the identified limiting single failure. Passive failures are not considered, except as event initiators, during the first 24 hours of the event. The following pieces of equipment are considered either as passive devices or are designed to be single failure proof and, therefore, are not subject to single failure:

- Main steam safety valves (MSSVs).
- PSRVs, when actuated by a spring-driven pilot. A single failure is considered when the PSRVs are switched to the electrically driven solenoids that reduce their opening setpoints for low-temperature overpressure protection (LTOP).
- Main steam relief isolation valve (MSRIV), normally closed. This valve is designed to be single-failure proof. Maintenance on the actuating solenoids is limited by TSs.

A loss-of-offsite power (LOOP) and a stuck RCCA are not considered single failures. A stuck RCCA is incorporated into the RT reactivity insertion. LOOP is incorporated whenever it makes the event more severe.

Operator errors are considered as potential single failures. An operator error is considered as a potential single failure for actions expected or directed by emergency procedure, e.g., failure to redirect EFW following FWLB. Operator error is not considered a potential single failure for actions that are not expected or directed by procedure, e.g., safety injection system (SIS) termination following a legitimate safety injection (SI) signal.

In addition to the most limiting active single failure of a safety-related system, the accident analyses incorporate an undetected failure of an SPND in the most limiting location.

15.0.0.3.9 Overview of the Incore Transient Methodology

The Low DNBR Channel and High linear power density (LPD) Channel Limiting Safety System Setting (LSSS) trip functions are designed to monitor the local behavior of departure from nucleate boiling (DNB) and LPD using incore self-powered neutron detectors (SPNDs), rather than inferring it from excore power measurement. The term “incore trips” is used to represent these two trips. Additionally, there are DNB and LPD Limiting Condition for Operation (LCO) functions used for monitoring purposes, which also utilize the incore SPND signals.

DNBR Protection

The minimum departure from nucleate boiling ratio (DNBR) at any point in the core during anticipated operational occurrence (AOO) events must be restricted to maintain the integrity of the fuel rod barriers to radionuclide release. This protection is afforded by the Low DNBR Channel LSSS and the DNB LCO, in conjunction with other DCS trips and LCO functions.

Low DNBR Channel

The Low DNBR Channel LSSS trip setpoints are established such that the point of minimum DNBR in the core will not experience DNB, at 95 percent probability and with 95 percent confidence. The DNBR trip limits are based upon (1) the point at which DNB occurs, and (2) uncertainties affecting the trip. The latter encompasses uncertainties related to:

- Process variable measurement (temperature, flow, pressure, and power).
- Critical heat flux correlation.
- Online DNBR algorithm.
- Assembly and rod bow.

The DNBR trip is based upon the evaluation of a closed-channel model in the plant computer. This model is adjusted in design calculations to provide DNBR predictions in close agreement with those from the approved sub-channel analysis code, LYNXT. Deviations in these DNBR predictions are accommodated as allowances in the setpoint established for the trip.

If the Low DNBR Channel LSSS trip function cannot resolve the degradation in DNBR during a transient event, the combination of the DNB LCO and other DCS trips are used to provide protection against DNB. The Low DNBR Channel LSSS is activated at all power levels above the P2 permissive setting (approximately 10 percent power), and is credited in safety analysis calculations initiated above that power level. The AOO events that provide the basis for the Low DNBR Channel trip are:

- Decrease in Feedwater Temperature.
- Increase in Feedwater Flow.
- Increase in Steam Flow.
- Inadvertent Opening of a Steam Generator Relief or Safety Valve.
- Uncontrolled Control Rod Assembly Withdrawal at Power.

- Control Rod Misoperation (System malfunction or operator error).
- Inadvertent Decrease in Boron Concentration in the Reactor Coolant System.
- Inadvertent Opening of a Pressurizer Relief or Safety Valve.

Although not specifically designed to intercede in postulated accidents (PA), the Low DNBR Channel LSSS may mitigate the radiological consequences of DNB-challenging PA events in which the DNB degradation can be resolved; for example, Main Steam Line Break (Section 15.1.5).

The Low DNBR Channel setpoints are established in statistical setpoint calculations using the methodology in Reference 2, considering static conditions. Safety analysis calculations consider dynamically compensated conditions, and are designed to demonstrate the adequacy of the trip compensation settings. If the combination of the trip compensation settings and the statically established setpoints are not sufficient to protect the specified acceptable fuel design limit (SAFDL), then either the compensation settings and/or the trip setpoints are adjusted to afford that protection. Because the DNB LCO is credited as an initial condition at the initiation of trip-basis events, the DNB LCO settings may alternatively be adjusted to provide additional initial DNB margin.

At power levels below the P2 permissive, the Low DNBR Channel LSSS is not active. Therefore, for safety analysis events initiated below this power level, a deterministic evaluation of the DNB performance during the event is performed directly with the approved sub-channel analysis code LYNXT as described in Section 4.4.4.5.2.

In safety analysis evaluations in which the Low DNBR Channel is active and predicted to afford primary protection, the compensation settings on the trip are examined to confirm that the SAFDL on DNB is not violated. For cases protected by other trips, the transient Δ DNBR allowance is examined to confirm it does not exceed that considered in the DNB LCO setpoint.

DNB LCO Setpoint

The DNB LCO function, in conjunction with DCS trips and other LCO functions, protects against events in which the Low DNBR Channel LSSS cannot resolve DNB margin degradation. This protection is afforded by imposing a minimum allowable DNBR threshold during steady-state operation, below which the plant cannot operate. The amount of initial DNBR margin represented by these limits is sufficient to accommodate the transient degradation in DNBR prior to the intercession of a DCS trip. The DNB LCO is credited in safety analysis as a restriction on the initial conditions permissible at the initiation of a transient event. The uncertainties considered in the DNB LCO setpoint are similar to those of the Low DNBR Channel LSSS.

Potentially limiting events that are protected in part by the DNB LCO are:

- Increase in Steam Flow.
- Loss of Forced Reactor Coolant Flow (Partial Loss).
- Loss of Forced Reactor Coolant Flow (Full Loss).
- Uncontrolled Control Rod Assembly Withdrawal at Power.

A Δ DNBR of 0.60, which bounds the Complete Loss of Forced Reactor Coolant Flow (Section 15.3.2) event, forms the basis for the DNB LCO settings credited in the safety analysis.

LPD Protection

The maximum LPD at any point in the core during AOO events must be restricted to maintain the integrity of the fuel rod barriers to radionuclide release. This protection is afforded by the High LPD Channel LSSS and the LPD LCO, in conjunction with other DCS trips and LCO settings.

High LPD Channel LSSS

The High LPD Channel LSSS setpoints are established such that the point of maximum LPD in the core will not experience either fuel centerline melt (FCM) or excessive cladding strain during trip-basis AOO events, at 95 percent probability and with 95 percent confidence. The trip LPD limit is based upon (1) an LPD value that conservatively represents the threshold at which FCM or clad strain limits are violated, and (2) uncertainties affecting the trip. The former is obtained from the approved fuel rod response code COPERNIC described in Table 4.1-2, which correlates local power density limits to fuel centerline temperature and clad strain limits. The latter encompasses uncertainties related to:

- Local power measurement.
- Variability in LPD due to fuel pellet manufacturing tolerances.
- Assembly and rod bow.

If the High LPD Channel LSSS cannot resolve the degradation in LPD during a transient event, the combination of the LPD LCO and other DCS trips are used to afford protection against FCM and clad strain. The High LPD Channel LSSS is activated at all power levels above the P2 permissive setting (approximately 10 percent power), and is credited in safety analysis calculations initiated above that power level. Trip-basis AOO events for the High LPD Channel trip are:

- Increase in Steam Flow.

- Uncontrolled Control Rod Assembly Withdrawal at Power.
- Control Rod Misoperation (System malfunction or operator error).
- Inadvertent Decrease in Boron Concentration in the Reactor Coolant System.
- Inadvertent Opening of a Pressurizer Relief or Safety Valve.

Although not specifically designed to intercede in PA events, the High LPD Channel LSSS may mitigate the radiological consequences of overpower PA events such as the Main Steam Line Break (Section 15.1.5) or Control Rod Ejection (Section 15.4.8).

The setpoints are established in statistical setpoint calculations using the methodology in Reference 2, considering static conditions. Safety analysis calculations consider dynamically compensated conditions, and are designed to demonstrate the adequacy of the trip compensation settings. If the combination of the trip compensation settings and the statically established setpoints are not sufficient to protect the SAFDL, then either the compensation settings and/or the trip setpoints are adjusted to afford that protection. Because the LPD LCO is credited as an initial condition at the initiation of trip-basis events, the LPD LCO settings may alternatively be adjusted to provide additional initial LPD margin.

In safety analyses in which the High LPD Channel is active and affords primary protection, the compensation settings on the trip are evaluated to protect the SAFDL. At power levels below the P2 permissive, the High LPD Channel LSSS is not active. Therefore, for safety analysis events initiated below this power level, deterministic calculations of the maximum LPD are examined to confirm that the SAFDL is not violated. For cases protected by other trips, the transient Δ LPD allowance is evaluated in relation to the LPD LCO setpoint.

LPD LCO

The LPD LCO function, in conjunction with DCS trips and other LCO functions, protects against events in which the High LPD Channel LSSS cannot resolve LPD margin degradation. This protection is afforded by imposing a maximum allowable local LPD threshold during steady-state operation, above which the plant cannot operate. The amount of initial LPD margin represented by these limits is sufficient to accommodate the transient degradation in LPD prior to the intercession of a DCS trip. The LPD LCO is credited in safety analysis as a restriction on the initial conditions permissible at the initiation of a transient event.

The LPD LCO setpoints are determined by combining uncertainties about the minimum of (1) the steady-state LPD credited in Loss of Coolant Accident (LOCA) calculations, and (2) the transient LPD limit less the maximum transient LPD

degradation for any LCO-basis event. The uncertainties considered in the LPD LCO setpoint are similar to those of the High LPD Channel LSSS.

Potentially limiting events that are protected in part by the LPD LCO are:

- Increase in Steam Flow.
- Steam System Piping Failures Inside and Outside of Containment.
- Uncontrolled Control Rod Assembly Withdrawal from a Subcritical or Low Power Startup Condition.
- Uncontrolled Control Rod Assembly Withdrawal at Power.
- Spectrum of Rod Ejection Accidents.
- Loss-of-Coolant Accidents Resulting from Spectrum of Postulated Piping Breaks within the Reactor Coolant Pressure Boundary.

Transient Analysis with Incore Trips

The transient analysis is performed with incore trip models decoupled from the system simulation code, S-RELAP5. The incore trip models are generically referred to as the “algorithm” or separately as the Low DNB Channel algorithm and High LPD Channel algorithm. The core boundary conditions for the algorithm are generated in S-RELAP5 and power distributions are generated in the nodal neutronics code, PRISM.

The Low DNB Channel and High LPD Channel algorithms are simulated to predict times at which the incore trip setpoints are reached, and to demonstrate the adequacy of the dynamic compensation on the trips. Table 15.0-7 lists the incore trip setpoints used in the accident analyses. The methodology for confirming the dynamic compensation is described in Section 9.4 of Reference 2.

The Low DNB Channel and High LPD Channel algorithms use the following measurements:

- The reactor power distributions derived from the SPNDs, which are part of the nuclear incore instrumentation.
- The primary system pressure derived from the primary pressure sensors.
- The core flow derived from the reactor coolant pump (RCP) speed sensors and the calibrated volumetric flow from a surveillance measurement.
- The reactor inlet temperature derived from the cold leg temperature sensors.

A COL applicant that references the U.S. EPR design certification will provide a report that demonstrates compliance with the following items applicable to the first cycle of operation:

- Examine fuel assembly characteristics to verify that they are hydraulically compatible based on the criterion that a single package of assembly specific critical heat flux (CHF) correlations can be used to evaluate the assembly performance.
- Verify that uncertainties used in the setpoint analyses are appropriate for the plant and cycle being analyzed.
- Verify that the DNBR and LPD satisfy SAFDL with a 95/95 assurance.
- Review the U.S. EPR FSAR Tier 2 analysis results for the first cycle to confirm that the static setpoint value provides adequate protection for at least three limiting AOO.

15.0.0.3.10 Plant Design Changes

The information presented in Section 15.0 represents the current U.S. EPR design. Some of the analyses presented in this section used slightly different values. In these cases the differences have been evaluated and found to have a negligible or conservative impact on the results and conclusions.

15.0.1 Radiological Consequence Analysis

This section is not applicable to new plants. The radiological consequences analyses are addressed in Section 15.0.3.

15.0.2 Computer Codes Used in Analysis

A summary of each principal computer code used in the accident analyses is presented in the following subsections. Additionally, Table 15.0-6 lists the code or codes used for each postulated event.

15.0.2.1 PRISM

The PRISM code is described in Section 4.3.3.

15.0.2.2 NEMO-K

The NEMO-K code is described in Section 4.3.3.

15.0.2.3 LYNXT

The LYNXT sub-channel thermal-hydraulic code is described in Section 4.4.

15.0.2.4 S-RELAP5

S-RELAP5 (Reference 3) is a general purpose thermal-hydraulic transient simulation code that evolved from the RELAP5 family of computer codes developed originally by the Idaho National Engineering Laboratory (INEL) for the NRC. The RELAP5 code is capable of simulating the hydraulic and thermal phenomena necessary to predict transients in both nuclear and non-nuclear systems involving mixtures of steam, water, noncondensable gas, and solute.

S-RELAP5 includes hydrodynamic models, heat transfer and heat conduction models, a fuel model, a reactor kinetics model, and control system and trip system models. S-RELAP5 uses a two-fluid, nonequilibrium, nonhomogeneous, hydrodynamic model for transient simulation of the two-phase system behavior. The hydrodynamics also include generic component models: pumps, valves, separators, jet pumps, turbines, and accumulators. Additionally, the hydrodynamics include some special process models: form loss at an abrupt area change, choked flow, and countercurrent flow limiting (CCFL). The code also includes user conveniences such as extensive input checking capability to help users detect input errors and inconsistencies, free-format input, restart, re-nodalization, and variable output edits.

A complete description of the PWR applications for large-break LOCA, small-break LOCA, and non-LOCA analysis methodologies are given in References 3 and 4. The Small-Break LOCA and Non-LOCA Sensitivity Studies and Methodology (Reference 8) describes the SG nodalization sensitivity analyses performed to support the small-break LOCA and non-LOCA analysis methodologies of Reference 3.

15.0.2.5 ORIGEN

ORIGEN 2.1 is a computer code for calculating the buildup, decay, and processing of radioactive materials described in (Reference 9). ORIGEN 2.1 includes additional libraries for standard and extended-burnup PWR and BWR calculations, which are documented in ONRL/TM-11018 (Reference 10).

15.0.3 Radiological Consequences of Design Basis Accidents

15.0.3.1 Introduction

The U.S. EPR design basis accident (DBA) radiological evaluations are based on the guidance in the SRP Section 15.0.3 (Reference 1) and RG 1.183. Analysis guidance is also obtained from other SRP sections related to specific aspects of a given evaluation; the event-specific evaluations explain the application of these other SRP sections. The DBA evaluations also address applicable interim acceptance criteria and guidance provided in Section 4.2, Interim Acceptance Criteria and Guidance for the Reactivity Initiated Events (Reference 1) as well as related regulatory issue summaries included in Regulatory Issue Summary (RIS) 2006-04, Experience with Implementation of

Alternative Source Terms (Reference 11).

The basic radiological acceptance criteria associated with the alternative source term (AST) methodology are found in 10 CFR 50.34(a)(1) for the offsite receptors, with a limit of 25 rem total effective dose equivalent (TEDE). 10 CFR 50, Appendix A, GDC 19 as incorporated by reference in 10 CFR 52.47(a)(1), includes the criteria for control room personnel (5 rem TEDE). These criteria, however, are used for evaluating potential reactor accidents of exceedingly low occurrence probability and low risk of public exposure to radiation. For events with higher probability of occurrence, the acceptance criteria for the offsite receptors are more stringent, while the criteria for the control room operators remains the same. Table 15.0-12—Radiological Consequences of U.S. EPR Design Basis Accidents (rem TEDE) summarizes the results from the radiological evaluations and provides the corresponding dose acceptance criteria.

15.0.3.2 Event Categorization

The DBAs are categorized following the guidance in SRP 15.0.3 (Reference 1) and RG 1.183. SRP 15.0.3, Table 1 (Reference 1) and RG 1.183, Table 6, list the offsite dose acceptance criteria for the DBAs. The MCR dose acceptance criterion for the events analyzed is 5 rem TEDE, as required in 10 CFR 50, Appendix A, GDC 19.

The radiological consequences of the following DBAs have been evaluated:

- Small line break outside of the Reactor Building.
- SGTR.
- MSLB outside of the Reactor Building.
- RCP locked rotor.
- Rod ejection.
- Fuel handling accident.
- LOCA.

The Reactor Building includes the Inner Containment Building, the Outer Shield Building and includes the annulus space. The radiological consequences evaluation for each DBA includes the radiological habitability of the MCR and the technical support center (TSC), which is within the MCR envelope. The post-LOCA Reactor Building water chemistry analysis has been performed and demonstrates that the in-containment refueling water storage tank (IRWST) solution pH remains above 7.0 for the duration of the accident in accordance with RG 1.183, Appendix A, Item 2.

15.0.3.3 Analytical Assumptions

The analytical assumptions that are common to the DBA evaluations are presented in this section.

15.0.3.3.1 Non-Safety-Related Systems Credited in the Analyses and Operator Action

The DBA radiological evaluations credit safety-related structures, systems, or components (SSC) to mitigate the radiological consequences of a DBA. However, non-safety-related SSC are assumed operational if the assumption results in a more limiting radiological consequence. Additionally, certain non-safety-related backup PSs and components are credited in the design basis analyses as described in Section 15.0.0.3.6. Operator actions from the MCR are assumed to take place 30 minutes or later from the start of accident.

15.0.3.3.2 Loss of Offsite Power Assumptions

LOOP coincident with the event or with an RT (if more restrictive) is assumed for the DBA radiological evaluations. In line with current regulatory requirements for new applications, a LOOP is not considered a single, active failure, but an addition to a single, active failure.

15.0.3.3.3 Atmospheric Dispersion Factors

The short-term atmospheric dispersion factors applied to the radiological evaluations are presented in Table 2.1-1—U.S. EPR Site Design Envelope for the exclusion area boundary (EAB) and low population zone (LPZ). The MCR/TSC atmospheric dispersion factors are presented in Table 2.1-1.

The MCR/TSC analytical model for the radiological habitability evaluations includes a primary intake flow from one location, with and without filtration, and a secondary unfiltered intake flow from a different location. The single intake simplification requires time-dependent effective atmospheric dispersion factors and associated MCR intake filter bypass fractions. The MCR/TSC effective χ/Q values are determined following the guidance in RG 1.194, Section 3.3.2.1, and are scenario dependent. The radiological event descriptions in this chapter include these effective χ/Q factors and bypass fractions.

15.0.3.3.4 Core Radionuclide Inventory Assumptions

The design basis core radionuclide inventory is calculated using the ORIGEN-2.1 software (Reference 9) along with extended burnup libraries from ORIGEN-2 high burnup reactor models (Reference 10). The U.S. EPR-specific parameters listed in Table 15.0-13—Parameters Used to Calculate Design Basis Core Radionuclide Inventory are used to determine the DBA core radionuclide inventory. The bounding radionuclide inventory is derived from a parametric evaluation with fuel enrichments

ranging from 2–5 wt% in U-235 and burnup steps ranging between approximately 5 and 62 GWD/MTU. Each parametric case assumed continuous reactor operation at full power without any refueling outage. The maximum activity for each radionuclide from the parametric cases is selected to provide a bounding core radionuclide inventory for the listed fuel-enrichment and burnup ranges. The resulting core inventory is shown in Table 15.0-14—Design Basis Core Radionuclide Inventory.

The core inventory in Table 15.0-14 also provides the source for computation of the RCS radionuclide concentrations. The RCS iodine and noble gas concentrations are assumed to initially be at the maximum equilibrium TS limits for continued operation, while the alkalis are assumed to be at the design basis values corresponding to a 0.25 percent failed fuel fraction. Table 15.0-15 provides the RCS initial concentrations. Corresponding secondary side radionuclide concentrations are provided in Table 15.0-16—U.S. EPR Secondary Coolant Bounding Concentrations.

15.0.3.3.5 Iodine Appearance Rates

The iodine appearance rates are used in DBA analyses that require the assumption of an accident-induced concurrent iodine spike, such as a SGTR and a MSLB. These appearance rates are shown in Table 15.0-17—Iodine Appearance Rates into RCS from Defective Fuel and are based on an RCS purification flow rate of 120,000 lbm/hr. The flow rate used is 60 percent higher than the nominal value of 75,000 lbm/hr used in the definition of the design basis RCS coolant concentrations; use of this higher flow rate results in conservatively higher iodine appearance rates.

15.0.3.3.6 Analytical Methods

The DBA analyses follow the guidance of SRP 15.0.3 (Reference 1) and RG 1.183. This methodology addresses the submersion and inhalation doses and the direct shine doses from contained or external sources. The dose conversion factors applied are from Federal Guidance Reports 11 (Reference 12) and 12 (Reference 13).

15.0.3.4 Receptor Variables

15.0.3.4.1 Main Control Room/Technical Support Center Modeling

A summary of MCR characteristics is presented in Table 15.0-18—Summary of MCR/TSC Characteristics. The TSC is within the MCR pressure boundary and therefore has the same habitability.

MCR Envelope Description

The MCR envelope is located in Safeguard Building Divisions 2 and 3 of the U.S. EPR. Personnel entry to the MCR area is via double-door vestibules. The MCR envelope ventilation system, called the “SAB” design provides a slight positive pressure within the MCR area to preclude uncontrolled inleakage through walls, ceilings, doors, pipe

penetrations, and cable penetrations. This positive pressure is maintained during both normal and accident conditions. The outside air supply filtration and air conditioning systems are within the pressure boundary, thus minimizing the potential inleakage of contaminated air into the MCR via fan shafts or ductwork connections. A conservative assumption of an unfiltered inleakage rate of 50 cfm is used in the analyses.

The free air volume of the MCR envelope is 200,000 ft³. This volume corresponds to approximately 80 percent of the gross volume (concrete-to-concrete) within the pressure boundary. Of the free air volume, about 133,000 ft³ corresponds to the MCR and TSC; the balance corresponds to the HVAC room, which is located above the normally occupied area of the MCR. Approximately 20 inches of reinforced concrete floor separates the HVAC space from the MCR and TSC.

Two redundant MCR air intakes are located on the roofs of Safeguard Building Divisions 2 and 3. A portion of the exhaust from the MCR is directed to the environment via the kitchen and sanitary rooms, with the balance directed to the electrical sections of the Safeguard Building serviced by the Safeguard Building HVAC system, called the "SAC". The outside air supply through each intake is automatically diverted through its own charcoal filtration system for the removal of halogens and other radioactive particulates. This system is actuated by either a primary containment isolation signal (PCIS) or by high radiation levels in the air intake ducts. The filtered outside air supply is 1000 cfm (postaccident); this supply rate corresponds to 0.3 volume changes per hour, a rate in excess of the 0.25 changes per hour in the SRP, Section 6.4.II.3, Pressurization Systems, (Reference 1) below which periodic testing of the MCR pressurization of at least one-eighth-inch water gauge is required.

The radiological analyses assume automatic actuation of one of the two MCR SAB charcoal filtration systems. The other filtration system is assumed to fail and is unavailable for the entire accident duration. The MCR SAB charcoal filtration system that is credited corresponds to the one in Safeguard Building Division 3. This system is selected because the outside air intake is closest to the bounding atmospheric release points (base of vent stack and Loop 3 SG silencer). The assumption of the Loop 3 SG release is conservative for the radiological evaluations and may differ from other thermal-hydraulic safety analysis assumptions. Filtration credit is taken after system realignment and is conservatively set at one minute after the start of the PA. Figure 15.0-4—MCR Envelope Post-Accident HVAC Filtration Mode Model shows the system configured for filtration.

Unfiltered Inleakage

The unfiltered rate of inleakage into the MCR is assumed to be 50 cfm (an SAB system requirement). This assumed rate includes 10 cfm for ingress and egress via the double-door vestibules, as specified in the SRP, Section 6.4.III.3.E(ii) (Reference 1).

Unfiltered inleakage to the MCR envelope is from the areas ventilated by the SAC. The airborne concentration within the areas that the SAC services is conservatively assumed the same as that at the SAC intake. The SAC HVAC system has two intakes separated from the SAB intakes. As with the MCR SAB main intake, unfiltered inleakage into the MCR envelope is assumed to be via the SAC Division 3 intake for the accident duration.

Filtered Recirculation Flow

The MCR post-isolation filtration system is credited for the postaccident removal of airborne halogens and other particulates within the MCR pressure boundary. Specifically, 3000 cfm of the total recirculation flow is diverted through the charcoal filtration system, with a filtration efficiency of 99 percent. A single charcoal filtration system serves both the intake and recirculation flows, with a total capacity of 4000 cfm (1000 cfm outside air intake flow plus 3000 cfm recirculation flow).

Finite-Cloud Correction

The dose to MCR personnel due to the external gamma radiation from airborne radioactivity within the MCR is adjusted using the nuclide-specific hemispherical finite-cloud correction for the non-LOCA events, and the Murphy/Campe model for the LOCA. With the exception of the LOCA, the entire free air volume of the MCR (200,000 ft³) from both elevations is used as the submersion volume, despite the approximately 20 inch concrete slab separating the two floors. This assumption is conservative since it overestimates the submersion dose (DDE). This conservative assumption has no impact on the overall MCR TEDE dose, however, since the inhalation pathway is the primary dose contributor. For the LOCA, the DDE is reduced by about 15 percent to account for the two-floor MCR pressure boundary.

Direct Shine from Non-Airborne Sources

In addition to the DDEs to MCR personnel resulting from contaminated air entering the MCR pressure boundary, and in accordance with RG 1.183, Section 4.2.1, the analysis also considers the following exposure pathways:

- Radiation shine from the external radioactive plumes released during the accident.
- Radiation shine from radioactive material in the Reactor Building.
- Radiation shine from radioactive material in systems and components inside or outside the MCR envelope (e.g., MCR HVAC filters).

Due to the massive concrete structures protecting the Reactor Building and the MCR (in excess of 6 ft of concrete), the only potential source of direct-shine radiation to the MCR personnel is radioactivity buildup in the MCR charcoal filtration system. Filter

shine doses to MCR personnel are relatively low and are included in the calculated MCR TEDE doses.

15.0.3.4.2 Offsite Receptors

The offsite receptors of interest in the DBA radiological evaluations are at the EAB and the LPZ. Variables related to these two receptors are presented in Table 15.0-19—Offsite Receptor Variables.

15.0.3.5 Small Line Carrying Primary Coolant Break Outside of the Reactor Building Accident

This section addresses the radiological consequences associated with the postulated failure of small lines carrying primary coolant outside containment. This evaluation considers the rupture of coolant lines in the nuclear sampling system (NSS), and in the CVCS. In the U.S. EPR design, no instrument lines carry primary coolant outside of containment.

15.0.3.5.1 Sequence of Events and Systems Operations

The evaluation identifies two small line failures outside containment that bounds other breaks, one break each in the NSS and CVCS. The postulated small-line breaks (SLBs) and scenario assumptions are as follows:

- SLB 1. A double-ended guillotine break of one of the three NSS one-quarter inch sampling lines to the RCS located between the containment penetration and the heat exchanger, while the sampling system is in operation and the isolation valves are open.
- SLB 2. A double-ended guillotine break of the CVCS six-inch line between the volume control tank (VCT) and the VCT suction valves.

SLB 1 and SLB 2 require manual operator action for isolation (i.e., these breaks are discharging RCS coolant for 30 minutes) and therefore lead to bounding radiological consequences. Other size small breaks evaluated either lead to automatic isolation or release of a smaller inventory.

Given the difference in the break line sizes in SLB 1 and SLB 2, and assuming the same break isolation time in the two scenarios (by operator action), the CVCS line break (SLB 2) leads to a significantly higher coolant release than the NSS line break. The CVCS line break is downstream of the purification system, which has a 99 percent filtration efficiency for the iodines and is at reduced temperature of 122°F, as compared to the greater than 560°F for the RCS conditions at the NSS break. Although a significantly higher coolant release occurs, no coolant flashing occurs at the CVCS break; therefore, iodine release to the environment is relatively insignificant.

However, the CVCS line break leads to a significantly higher release of noble gases than the NSS line break.

The RCS iodine and noble gas concentrations are assumed initially to be at the proposed maximum equilibrium TS limits for continued operation, as described in SRP 15.6.2, Radiological Consequences of the Failure of Small Lines Carrying Primary Fluid Outside of Containment (Reference 1), while the alkalis are assumed to be at the design basis values.

The postulated breaks do not cause fuel damage since the loss of RCS inventory is relatively small and can be compensated by the safety injection system. Nonetheless, the accidents are assumed to induce a concurrent iodine spike as a result of the postulated reactor shutdown or depressurization. This iodine spike increases the iodine appearance rate into the primary coolant from pre-existing fuel defects (see Table 15.0-17) by a factor of 500 in accordance with RG 1.183. In line with the guidance in RIS 2006-04 (Reference 11), the analysis considers the release of iodines, noble gases, and alkalis. Other radionuclides in the released coolant are assumed to remain within the liquid phase.

The fraction of the iodines and alkalis becoming airborne and available for release to the atmosphere is equal to the fraction of the coolant flashing to steam in the depressurization process, determined by assuming the discharge is a constant enthalpy process as described in SRP 15.6.2 (Reference 1). Flashing fractions are based on RG 1.183, Appendix A, Section 5.4. The noble gases released from the primary system are assumed to be released to the environment without reduction or mitigation.

15.0.3.5.2 Input Parameters and Initial Conditions

The general assumptions applied in this evaluation are as follows:

- The break flows in the NSS lines are conservatively based on the assumption that the break locations are at the connecting points to the RCS, and the discharge coefficients are assumed to be equal to one.
- MCR operator action to isolate any break is assumed to be performed at 30 minutes. This assumption bounds the 20 minute interval specified in the SRP, Section 6.4 (Reference 1) for operator action.
- No credit is taken for mixing, holdup, plateout, or decay within the Fuel Building (where the breaks are postulated to take place), nor is any credit taken for exhaust filtration by the ventilation system.
- The MCR characteristics and automatic filtration actuation are described in Section 15.0.3.4.1.

Table 15.0-20—Design Input for Failure of Small Lines Carrying Primary Coolant Outside Containment through Table 15.0-22—MCR Composite χ/Q and Filter-Bypass

Fractions for Small-Line Break Releases at the Vent Stack Base summarize the key design inputs for the small line break accident scenario. Figure 15.0-5—Small Line Break Accident Scenario illustrates how this scenario is modeled.

15.0.3.5.3 Results

The radiological consequences of a postulated small line break in the NSS and the CVCS for two systems were evaluated: a line break in the one-quarter-inch NSS line and a line break in the six-inch CVCS line. The results of this evaluation are summarized Table 15.0-23—Small Line Break - Dose Results. The NSS line break, with the relatively significant iodine release, leads to the bounding dose to the MCR operators and at the offsite receptors. At the EAB and LPZ, the TEDE doses are 1.8 and 0.32 rem, respectively; these doses are a “small fraction” (i.e., 10 percent or less) of the 25 rem TEDE limit. For the MCR, with automatic isolation in one minute actuated by the radiation monitor in the air intake duct, the TEDE dose is only 65 mrem, well below the 5 rem regulatory limit. The TEDE doses calculated meet the acceptance criteria in SRP 15.0.3 (Reference 1).

15.0.3.6 Steam Generator Tube Rupture Accident

This section addresses the radiological consequences associated with a postulated SGTR DBA. Four potentially limiting SGTR thermal-hydraulic responses were analyzed to identify the bounding scenario. In three cases, RT by operator action and concurrent LOOP were postulated to take place at 30 minutes into the accident. In the fourth case, RT takes place at about 20 minutes because of low PZR pressure and is followed by a LOOP. Atmospheric releases are via the condenser evacuation system until RT and via the SG MSRTs thereafter until a cold shutdown condition is maintained. Adequate core cooling precludes fuel failure.

Two ASTs are considered: an SGTR with a pre-accident iodine spike and an SGTR with an accident-induced concurrent iodine spike. These source terms are described further in the following sections.

15.0.3.6.1 Sequence of Events and Systems Operations

Table 15.0-24—SGTR Accident Time Line presents the time line associated with the bounding SGTR DBA. The following conditions and system failures are considered in the analysis:

- LOOP.
- The main steam relief control valve (MSRCV) of the affected SG fails in the fully open position.
- Loss of one of the two redundant charcoal filtration systems of the MCR, which is assumed to fail and be unavailable for the accident duration.

15.0.3.6.2 Input Parameters and Initial Conditions

The design input is presented in Table 15.0-25—SGTR Design Input through Table 15.0-28—MCR Composite χ/Q and Filter-Bypass Fractions Post-SGTR Releases via the SG 3 Silencer. The following additional inputs are incorporated into the model for these cases:

- The postulated alternative SGTR source terms are as follows:
 - An SGTR with a pre-accident iodine spike, in which a reactor transient had occurred prior to the PA and raised the primary coolant concentration to the proposed maximum operational value of 60 $\mu\text{Ci/gm}$ dose equivalent (DE) I-131 (in accordance with RG1.183, Appendix F).
 - An SGTR with an accident-induced concurrent iodine spike of eight-hour duration, in which the iodine spike corresponds to an increase in the design basis iodine appearance rate into the primary coolant (see Table 15.0-17) by a factor of 335 (in accordance with RG 1.183, Appendix F).
- In accordance with the guidance in NRC RIS 2006-04 (Reference 11), the analysis considers the release of iodines, noble gases, and alkalis. All other radionuclides are assumed to remain within the liquid phase (RCS and secondary coolant). The applicable source terms are presented in Table 15.0-15 and Table 15.0-16. Barium-137m is also included in the analysis because it is in secular equilibrium with its parent, Cs-137.
- The three intact SGs are combined (modeled) into a single, larger SG, and the ruptured SG is modeled separately. A condensed list of the key thermal-hydraulic input variables is presented in Table 15.0-27.
- The tube rupture is assumed to occur in SG 3. The atmospheric releases consist of the secondary-side activities, RCS leakage via the ruptured SG, and normal leakage via the other three intact SGs. The early releases are via the condenser evacuation system until RT (30 minutes into the accident by operator action), and via the MSRTs thereafter. Iodine and alkali depletion due to deposition within the condenser is credited based on the Palo Verde license amendment (Reference 14) and NRC NUREG-1228 (Reference 15).
- The halogen and alkali decontamination factor (DF) due to deposition within the condenser system is set equal to 100 (Reference 14). The DF is conservative as noted in NUREG-1228 because, during this phase, the condenser is available and the MSL does not isolate. In this case, only the noble gas in the contaminated water is assumed to be released via the steam jet air ejector exhaust, which implies a condenser iodine DF of infinity.
- The atmospheric dispersion factors for the MCR intake and pressure boundary are selected to correspond to the closest MSRT (for SG 3) and bound those for releases via the vent stack from the condenser evacuation system.

The accident scenario for releases via the ruptured SG is shown in Figure 15.0-6—SGTR - Ruptured SG Release Scenario Diagram. The corresponding releases via the intact SGs are similar.

15.0.3.6.3 Results

The evaluation of the radiological consequences of an SGTR considers two iodine spike scenarios: a pre-accident iodine spike and a concurrent iodine spike. The steam release is initially via the condenser and vent stack for 30 minutes, while the plant is at full power. The release is via the SG MSRTs and silencers thereafter. A summary of the results is presented in Table 15.0-29—SGTR Dose Summary. The filter bounding shine dose to MCR personnel amounts to approximately 0.006 rem for the concurrent iodine spike. These doses are negligible in comparison to the DDEs. The TEDE doses calculated meet the acceptance criteria in SRP 15.0.3 (Reference 1).

15.0.3.7 Main Steam Line Break Outside of Reactor Building Accident

This section addresses the radiological impact associated with the postulated failure of steam system piping outside the Reactor Building. Pipe failures inside containment or in the annulus space between the Containment Building and surrounding buildings are not addressed since they are radiologically bounded by similar failures outside the Reactor Building. The analysis also incorporates the clarifications provided in NRC Regulatory Issue Summary RIS 2006-04, Section 9 (Reference 11), namely the inclusion of the alkalis (in addition to the halogens and noble gases) in the radiological evaluation of accidents involving SG releases. The PA scenario is based on the guidance in the SRP, Section 15.0.3 (Reference 1) and RG 1.183, Appendix E.

The limiting accident is a double-ended guillotine break of a MSL in the valve compartment in Safeguard Building Division 4, upstream of the MSIV. The affected MSL pressure instantly reaches the setpoint for actuation of RT, TT, and MSL isolation. The atmospheric releases occur via the MSRTs and silencers of the unaffected SGs, because of the plant cooldown process without the main condenser, and via Canopy Point 1 for the SG with the broken MSL (as illustrated in Figure 15.0-7—MSLB Scenario Diagram). The releases from the unaffected SGs terminate in eight hours (time of RHR cut-in), and those from the affected SG terminate in nine hours (time at which the RCS temperature drops below 212°F).

The evaluation objectives include the determination of maximum DNB-induced cladding failure, and maximum fuel centerline melt (FCM)-induced fuel melt, that can be accommodated, independently, for an MSLB accident without exceeding 90 percent of the dose acceptance criterion at any receptor. Thus, the analyses consider the following source term scenarios:

- A pre-accident iodine spike.

- An accident-induced concurrent iodine spike.
- DNB-induced cladding failure.
- FCM-induced fuel melt.

15.0.3.7.1 Sequence of Events and Systems Operations

The time line associated with the radiological evaluation of an MSLB is described in Table 15.0-30—MSLB Time Line.

The following system failures are considered in this analysis:

- Failure of control valve MSRCV in Loop 3 in the open position, leading to SG tube being uncovered for 30 minutes and a direct release to the atmosphere of flashing primary coolant leaking into SG 3. This release is terminated by closure of the MSRIV when the MSL pressure drops below about 590 psia.
- Loss of one (Division 2) of the two redundant charcoal filtration systems of the MCR, which is assumed to fail and be unavailable for the accident duration.
- No LOOP. Availability of offsite power at the time of the accident is more restrictive than LOOP, leading to a higher power burst and more induced uncovering of tubes. A LOOP is therefore not included. In addition, the MSL break is postulated to take place upstream of the SG 4 MSIV, such that failure of the MSIV to close does not need to be considered as a single failure.

15.0.3.7.2 Input Parameters and Initial Conditions

The design input is presented in Table 15.0-31—MSLB Design Input through Table 15.0-33—MCR Composite χ/Q and Filter-Bypass Fractions (MSLB Releases via the MSL Break and Canopy Pt. 1). For the MSLB source terms cases, the initial RCS concentrations, without iodine spiking, and the secondary-side concentrations are considered as dose contributors. The source terms used are presented in Table 15.0-15 for the RCS, Table 15.0-16 for secondary side, and Table 15.0-14 for the undecayed core inventory (along with a radial peaking factor of 1.7 and the gap fractions listed in Table 15.0-31). Barium-137m is also included in the analysis because it is in secular equilibrium with its parent (Cs-137). MSLB source term assumptions include:

- An MSLB with a pre-accident iodine spike, where a reactor transient has occurred prior to the PA raising the primary coolant concentration to the proposed maximum value of 60 $\mu\text{Ci/gm DE I-131}$.
- An MSLB with an accident-induced concurrent iodine spike of eight-hour duration, where the iodine spike corresponds to an increase in the design basis iodine appearance rate into the primary coolant (from fuel defects, as shown in Table 15.0-17) by a factor of 500.

- DNB-induced cladding failure to fuel rods operating at a radial peaking factor of 1.7.
- FCM-induced fuel melt to rods operating at a radial peaking factor of 1.7.

In line with the guidance in NRC RIS 2006-04 (Reference 11), the analysis also considers the release of halogens, noble gases, and alkalis. Other radionuclides are assumed to remain within the liquid phase (RCS and secondary coolant). Additionally, RCS leakage to SG 4 is assumed to be released through the break to the atmosphere without reduction or mitigation, via the Safeguard Building canopy. The release is modeled to last until the plant is cooled down to 212°F, attained at nine hours after accident initiation.

In view of the stuck-open MSRCV in Loop 3 and the ensuing uncovered SG tube, it is postulated that primary coolant leakage into SG 3 is released directly to the atmosphere (via the stuck-open MSRCV and silencer) for 30 minutes after the accident, without reduction or mitigation. It is further assumed that the stuck-open MSRCV resets and that SG 3 is used in the cooldown process.

The atmospheric release pathways used in the analysis are as follows:

- Through the MSL break, the depressurization device on the floor of the valve room where the accident takes place, and the Safeguard Building canopy, without holdup, plateout, or in-transit decay. This release consists of:
 - Instantaneous release of the entire secondary-side halogen and alkali inventories in SG 3 and SG 4, without reduction or mitigation.
 - Nine-hour release of primary coolant activity leaking through the SG 4 broken MSL, without reduction or mitigation (terminating at the time the RCS temperature drops to 212°F).
- Through the SG, MSRTs, and associated silencers on top of the Safeguard Building. This release consists of:
 - Thirty-minute release of primary coolant activity leaking through SG 3, without reduction or mitigation (during the modeled 30 minute tube uncovered period).
 - Seven-and-one-half-hour release of primary coolant activity (during plant cooldown) leaking through SG 3, without reduction or mitigation for the noble gases, but with credit for 99 percent water retention of the iodines (with a partition coefficient of 100) and of the alkalis (with an assumed one percent moisture carry over).
 - Eight-hour release of primary coolant activity (during plant cooldown starting at t=0) leaking through SG 1 and SG 2, without reduction or mitigation for the

noble gases, but with credit for 99 percent water retention of the iodines and of the alkalis.

15.0.3.7.3 Results

The potential radiological consequences of a steam system piping failure outside the primary containment are summarized in Table 15.0-34—MSLB Dose Summary for each of the four source terms analyzed. Each case includes the doses resulting from release of the initial RCS activity, without iodine spiking, and of the secondary-side activity. Without cladding failure and fuel melt, the concurrent iodine spike leads to the bounding doses at the receptors of interest. The limiting cladding-failure and fuel-melt fractions that result in 90 percent of the dose acceptance criteria at the critical receptor are 3.3 percent and 0.58 percent, respectively. The critical location is the MCR in both cases. The radiological basis employed in the fuel-melt scenario is that the entire uranium mass in any given fuel rod melts, releasing to the RCS 100 percent of the entire noble gas inventory and 50 percent of the halogens and alkalis. The filter-shine contribution to the total dose varies between 0.5 percent for the pre-accident iodine spike scenario to 9.2 percent for the cladding failure scenario. The MSLB radiological consequences were determined to bound those for a FWLB.

15.0.3.8 Locked Rotor Accident

This section addresses the radiological impact associated with the postulated locked rotor accident (LRA, also referred to as RCP rotor seizure). The PA scenario is based on the guidance in SRP, Section 15.0.3 (Reference 1) and RG 1.183, Appendix G. The analysis also incorporates the clarifications provided in NRC RIS 2006-04, Section 9, namely the inclusion of the alkalis (in addition to the halogens and noble gases) in the radiological evaluation of accidents involving SG releases.

This DBA scenario assumes that the plant has been operating at full power for an extended period of time. The RCS pump rotor in Loop 3 is postulated to undergo instantaneous seizure, leading to a rapid reduction in the flow within the loop and initiation of RT on low flow signal or low pump speed or both of these signals. The RT is coincident with a LOOP as specified in RG 1.183, Appendix G, Section 5.4. The MSIVs close and secondary side releases are initiated upon opening of the MSRTs. One of the MSRCVs is assumed to fail in the open position, with releases via this MSRT continuing until the MSRIV closes. The accident may lead to cladding failure. The evaluation objectives include the determination of maximum DNB-induced cladding failure that can be accommodated for this accident without exceeding 90 percent of the dose acceptance criterion at any receptor.

15.0.3.8.1 Sequence of Events and Systems Operations

The time line associated with the radiological evaluation of an LRA is shown in Table 15.0-35—LRA Time Line. The following conditions and system failures are considered in this analysis:

- LOOP coincident with the LRA.
- Failure of control valve MSRCV in Loop 3 in the open position, leading to SG tube becoming uncovered and a direct release to the atmosphere of flashing primary coolant leaking into SG 3. This release is terminated in 15 minutes by closure of the MSRIV when the MSL pressure drops below about 590 psia.
- Loss of one (Division 2) of the two redundant charcoal filtration systems of the MCR, which is assumed to fail and be unavailable for the accident duration.

15.0.3.8.2 Input Parameters and Initial Conditions

The design input is presented in Table 15.0-36—Design Input for Locked Rotor Accident and Table 15.0-37—MCR Composite χ/Q and Filter-Bypass Fractions RCP Locked Rotor Accident Releases via the SG 3 Silencer. The applicable source terms are presented in Table 15.0-15 for the RCS, Table 15.0-16 for secondary side, and Table 15.0-14 for the undecayed core inventory (along with a radial peaking factor of 1.7 and the gap fractions listed in Table 15.0-36). LRA source term assumptions include the following:

- A pre-accident iodine spike, in which a reactor transient has occurred prior to the PA raising the primary coolant concentration to the proposed maximum value of 60 $\mu\text{Ci/gm}$ DE I-131.
- DNB-induced cladding failure to 9.5 percent of the core, involving fuel rods operating at a radial peaking factor of 1.7.

In line with the guidance in NRC RIS 2006-04 (Reference 11), the analysis considers the release of halogens, noble gases and alkalis. Barium-137m is also included in the analysis because it is in secular equilibrium with its parent, Cs-137. Other radionuclides are assumed to remain within the liquid phase (RCS and secondary coolant).

The atmospheric release pathways are as follows:

- Through the unaffected SGs (SG 1, SG 2, and SG 4) and silencers.
 - Secondary coolant halogen and alkali activity release for an eight-hour interval from initial MSRT opening (assumed to be at $t=0$) to the end of cooldown through steaming and from the three SGs. Credit is given for 99 percent water retention of the halogens (with a partition coefficient of 100) and of the alkalis (with an assumed one percent moisture carry over).

- Primary coolant activity release for an eight-hour interval, because of leakage to and accumulation in the three intact SGs, without reduction or mitigation for the noble gases. Credit is given for 99 percent water retention of the halogens and alkalis.
- Through the stuck-open MSRCV and silencer (SG 3).
 - Release of the entire SG 3 secondary-side halogen and alkali activity, modeled as an exponential release leading to the atmospheric discharge of about 99.5 percent of the contents within 15 minutes.
 - Direct release to atmosphere, from 0–15 minutes, of primary coolant activity leaking through SG 3, without holdup, reduction, or mitigation during the assumed tube uncovered period.

The LRA accident scenario is illustrated in Figure 15.0-8—LRA Scenario Diagram.

15.0.3.8.3 Results

One of the objectives of the evaluation is to determine the maximum cladding failure that can be accommodated for an LRA without exceeding 90 percent of the dose acceptance criterion at any receptor. The acceptable cladding failure is 9.5 percent, dictated by the dose at the EAB. The MCR/TSC dose includes a direct-shine dose of 0.082 rem from the MCR charcoal filtration system. The potential radiological consequences of an LRA are summarized in Table 15.0-38—RCP LRA Dose Summary. The radiological consequences of the LRA bound the broken shaft event.

15.0.3.9 Rod Ejection Accident

This section addresses the radiological impact associated with the postulated rod ejection accident (REA). The analysis is based on the guidance in SRP Section 15.0.3 (Reference 1) and RG 1.183, Appendix H. The analysis also considers the fission-product gap inventory for reactivity-induced accidents and the interim acceptance criteria and guidance provided in Reference 1. The REA analysis for the U.S. EPR is assumes that the fission-product release fraction from fuel rods that overheat is the same as that from melted fuel. Finally, the analysis incorporates the clarifications provided in RIS 2006-04 (Reference 11), namely the inclusion of the alkalis (in addition to the halogens and noble gases) in the radiological evaluation of accidents involving steam generator releases.

An REA is defined as the mechanical failure of a RCCA drive mechanism casing, located on top of the pressure vessel, leading to complete ejection of the control rod and drive shaft to the fully withdrawn position. This event results in a relatively high rate of reactivity insertion and a prompt power burst. In line with the guidance in SRP 15.0.3 (Reference 1) and RG 1.183, two alternative accident scenarios are postulated as follows:

- Primary containment leakage pathway, whereby the entire radionuclide activity released from cladding failures and fuel overhear or melt becomes airborne within the primary containment and is available for release to the atmosphere as a result of containment leakage.
- Secondary-side leakage pathway, whereby the activity is retained within the RCS and is available for release to the atmosphere because of SG tube leakage during the plant cooldown phase (accomplished through steaming via the MSRT due to the assumed concurrent LOOP).

In an actual situation, both release pathways are expected to contribute to the radiological consequences. To avoid double counting the released radioactivity, both release pathways are analyzed independently, and the bounding case selected in accordance with RG 1.183, Appendix H, Section 3. Additionally, the evaluation objectives included the determination of maximum cladding failure and fuel overhear that can be accommodated for a REA without exceeding 90 percent of the dose acceptance criterion at any receptor. In compliance with SRP Section 4.2, Appendix B, (Reference 1), the EPR design ensures that post-REA peak fuel temperature will remain below incipient fuel-melting conditions.

15.0.3.9.1 Sequence of Events and Systems Operations

The time line associated with the radiological evaluation of an REA is presented in Table 15.0-39—Rod Ejection Accident Timeline. The following conditions and system failures are considered in the analysis:

- LOOP coincident with the REA.
- Loss of one (Division 2) of the two redundant charcoal filtration systems of the MCR, which is assumed to fail and be unavailable for the accident duration.

15.0.3.9.2 Input Parameters and Initial Conditions

The design input for the REA is presented in Table 15.0-40—Design Input for Rod Ejection Accident through Table 15.0-43—MCR Composite (χ/Q)s and Filter-Bypass Fractions, Post-REA Secondary-Side Leakage Pathway. The accident-induced cladding failure and fuel overhear results are listed in Table 15.0-44—REA Dose Summary limit the radiological consequences of an REA to less than 90 percent of the dose acceptance criterion at any receptor. Additionally, the REA source term is assumed to consist of the following three components:

- A pre-accident iodine spike of 60 $\mu\text{Ci/gm}$, resulting from a reactor transient taking place prior to the REA and raising the iodine RCS concentration to the maximum value permitted by the proposed TS (similar to an MSLB, as described in RG 1.183, Appendix E, Section 2.1).

- Accident-induced cladding failure to fuel rods operating at a radial peaking factor of 1.7, with 10 percent of the fuel rod halogen and noble gas inventory in the gap, and 12 percent of the alkali inventory.
- Accident-induced fuel overheating, involving the release from the affected fuel of:
 - 100 percent of the fuel rod noble gas inventory and 25 percent of the halogens and alkalis to the primary containment (for the primary containment leakage pathway).
 - 100 percent of the fuel rod noble-gas inventory and 50 percent of the halogens and alkalis to the RCS (for the secondary-side leakage pathway).

In line with the guidance in NRC RIS 2006-04 (Reference 11), the analysis of the secondary-side leakage pathway considers the release of halogens, noble gases, and alkalis. Barium-137m is also included in the analysis because it is in secular equilibrium with its parent, Cs-137. Other radionuclides are assumed to remain within the liquid phase (RCS and secondary coolant).

The same radionuclides are present for both the primary containment and secondary-side leakage pathways, with the exception of the increased release of halogens and alkalis to the RCS for the secondary-side leakage pathway. The release points to the atmosphere are as follows:

- Primary containment leakage pathway: base of vent stack.
- Secondary-side leakage pathway: four silencers on top of Safeguard Building Divisions 1 and 4 (with equal steaming rates via each MSRT).

The REA scenario diagrams are shown in Figure 15.0-9—REA - Primary Containment Leakage Scenario Diagram for the primary containment leakage and Figure 15.0-10—REA - Secondary-Side Leakage Scenario Diagram for the secondary-side leakage pathway.

15.0.3.9.3 Results

The potential radiological consequences of an REA are summarized in Table 15.0-44. One of the objectives of the evaluation was to determine the maximum cladding failure and fuel overheating that can be accommodated for an REA without exceeding 90 percent of the dose acceptance criterion at any receptor. The acceptable fuel failures are as shown in the table, dictated by the dose at the EAB. The overheating fraction is selected to correspond to 4 percent of the cladding failures and is on a full-core mass basis.

15.0.3.10 Fuel Handling Accident

This section addresses the radiological impact associated with a postulated design basis fuel handling accident (FHA) at the U.S. EPR. The accident is postulated to occur either in the Containment Building or in the Fuel Building. The PA scenario is based on the guidance in SRP, Section 15.0.3 (Reference 1) and RG 1.183, Appendix B.

A fuel handling accident is postulated to take place at the start of fuel movement, 34 hrs after reactor shutdown (all rods in). In this PA, it is assumed that the peak-powered assembly, operating at a radial peaking factor of 1.7, drops onto other assemblies. This action leads to fuel damage equivalent to cladding failure of all 265 fuel rods within the dropped assembly and to the ensuing release of the entire fuel assembly gap inventory.

Other fuel handling accidents, such as a spent fuel cask falling or tipping into the spent fuel pool (SFP), are prevented by the design of the spent fuel handling equipment. The spent fuel cask and transfer machine are located in a separate room from the SFP area, which prevents a cask from being in the SFP area altogether. Fuel handling equipment and procedures are described in Section 9.1.4, and cask handling operations are described in Section 9.1.4.2.1.

15.0.3.10.1 Sequence of Events and Systems Operations

The time line associated with the radiological evaluation of an FHA is shown in Table 15.0-45—Fuel Handling Accident Timeline. The FHA scenario is illustrated in Figure 15.0-11—FHA Scenario Diagram.

The following conditions and system failures are considered in this analysis:

- LOOP coincident with the FHA.
- Loss of one of the two redundant charcoal filtration systems of the MCR (the one in Division 2), which is assumed to fail and be unavailable for the accident duration.

15.0.3.10.2 Input Parameters and Initial Conditions

The design input for this DBA analysis is presented in Table 15.0-46—Design Input for Fuel Handling Accident and Table 15.0-47—MCR Composite (γ/Q)s and Filter-Bypass Fractions for FHA Releases. The same accident scenario is used to evaluate the two potential locations of the FHA: inside open containment and the Fuel Building. The decay time for start of fuel movement (34 hrs) is selected to result in 90 percent of the regulatory limit at the worst-case receptor.

The listed gap release fractions in Table 15.0-46 are acceptable for use with the currently approved LWR fuel with peak burnup of 62 GWD/MTU provided that, for

burnups exceeding 54 GWD/MTU, the maximum linear heat generation rate (LHGR) does not exceed 6.3 kW/ft peak rod average power (RG 1.183, Table 3, Footnote 11). The U.S. EPR design meets this guidance.

The water depth through which the released activity bubbles to the water surface is in excess of 23 feet, thus retaining the alkalis and leading to an overall reduction of the halogens by a factor of 200 (per RG 1.183, Appendix B, Section 2). All released noble gases escape to the containment or refueling-level atmosphere.

Additionally, in accordance with RG 1.183, Appendix B, Section 4.1, the radioactive material that escapes the fuel pool is assumed to be released to the environment over a two-hour interval. Analytically, this is accomplished by using a building air exchange rate of 2.5 air changes per hour, leading to 46.5 percent of the airborne activity within the Reactor Building being released within 15 minutes and to a 99.3 percent release within two hours. The atmospheric release is assumed to occur at the base of the vent stack. Filtration of the release is not credited.

For the U.S. EPR peak assembly (with a radial peaking factor of 1.7), the fuel rod bounding internal gas pressure is lower than the limit of 1200 psig specified in RG 1.25.

15.0.3.10.3 Results

The potential radiological consequences of an FHA taking place at the U.S. EPR, either within the Reactor Building with open containment or in the Fuel Building, are summarized in Table 15.0-48—FHA Dose Summary. The 34-hour decay prior to fuel movement is selected to result in less than 90 percent of the dose acceptance criterion at the receptors of interest; the critical receptor is at the EAB. The filter-shine dose to MCR personnel is relatively insignificant, about 2.2 mrem for continuous occupancy.

15.0.3.11 Loss of Coolant Accident

This section addresses the radiological consequences associated with the postulated LOCA, defined in 10 CFR 50, Appendix A, as a PA that results from coolant inventory loss at a rate in excess of the RCS makeup capability. The U.S. EPR radiological consequences from a LOCA are evaluated by applying the AST methodology in RG 1.183.

15.0.3.11.1 Sequence of Events and System Operations

The LOCA radiological consequences sequence of events is based on RG 1.183. The LOCA is assumed to occur coincident with a LOOP and the radiological sequence of events listed in Table 15.0-49—LOCA Radiological Sequence of Events Post-LOCA includes the time-phase releases in RG 1.183, Table 4.

The U.S. EPR is licensed with leak-before-break methodology. Nonetheless, the LOCA radiological consequences evaluation does not credit the leak-before-break gap release phase onset of 10 minutes, available (per RG 1.183, Section 3.3) for plants with leak-before-break methodology.

15.0.3.11.2 Input Parameters and Initial Conditions

The core radionuclide inventory is provided in Table 15.0-14. Ten of the listed radionuclides have been omitted from the LOCA dose calculation based on their limited dose potential: Kr-83m, Br-83, Br-85, I-129, I-134, Rb-86m, Ag-110, Ba-139, Y-93, and La-142. All other Table 15.0-14 radionuclides are represented.

The U.S. EPR plant model uses inputs from Table 15.0-50—LOCA Inputs as well as a combination of the Power's 10th percentile and Henry's natural aerosol deposition rates for a PWR in accordance with NUREG/CR-6604, which describes RADTRAD (Reference 16). The U.S. EPR plant model applied in the evaluation consists of the following compartments (see Figure 15.0-12—Model for the Loss of Coolant Accident Analysis):

- The Reactor Building, primary containment (PC).
- The Shield Building annulus space, secondary containment (SC).
- The Safeguard Building, consisting of four separate structures served by a single ventilation system with sufficient redundancy to withstand single failure.
- The IRWST, the source of engineered safety feature (ESF) liquid leakage into the SG control volume.
- The MCR envelope.

Two release pathways are considered in the analysis, primary containment leakage and ESF component leakage. Details on these two pathways are as follows:

Containment Leakage Pathway

The source term consists of the following:

- Primary coolant pre-accident activity, at concentrations corresponding to the proposed limits of 1 $\mu\text{Ci/gm}$ DE I-131 and 210 $\mu\text{Ci/gm}$ DE Xe-133.
- Core releases, based on Table 15.0-14 and the time-phased release fractions specified in RG 1.183.

All core releases are assumed to be to the primary containment atmosphere. The loss mechanisms of airborne radioactivity within the primary containment include decay, depletion through natural deposition, and depletion through purge flow (for 10 s at the

start of the LOCA) and leakage. Natural deposition of the particulates was based on a combination of the Powers and Henry models in RADTRAD (Reference 16), with a smooth transition between the two models (at 22.2 hrs), as shown in Table 15.0-52—Effective Natural Deposition Decontamination Coefficients. Particulate removal was assumed to go on indefinitely, although according to the Henry formulation, the removal rate becomes very small over time. The deposition-removal constants for the particulates were conservatively applied to the elemental iodines, but the latter were limited to a total decontamination factor of 100 (attained in about 82 hours). The organic iodines are not affected. Section 15.0.3.12 demonstrates that the IRWST pH remains above 7.0 for 30 days; therefore, iodine re-evolution is not considered inside containment.

The generation of noble gases by the decay of released halogens is accounted for, wherever the latter may be (airborne, within post-LOCA liquids, or on filters).

Releases to the atmosphere are as follows:

- At the start of the accident, the containment was assumed to be in the purge mode. The purge flow is to the vent stack, and is terminated within 10 s because of PC isolation. Exhaust filtration is not credited.
- After purge-flow termination, leakage from the primary containment was based on the proposed limit of 0.25 percent per day for the first 24 hours, and 50 percent of this value thereafter. Holdup within the secondary buildings is not credited.
- During the 305-second annulus drawdown time (by the KLB system), and of the Safeguard Building and Fuel Building (by the KLC), 100 percent of the primary containment leakage was assumed to be instantly released to the environment unfiltered, at a location adjacent to the Division 3 main steam silencer (closest point to the MCR intakes). Note that the annulus is normally maintained at the required negative pressure during normal operation by a non-safety HVAC system.
- Following the end of drawdown, primary containment leakage is transported directly to the atmosphere at the base of the vent stack without mixing, and is filtered by the AVS (99 percent filtration efficiency for all species). Primary containment leakage to areas serviced by the SBVS under accident conditions (namely, the mechanical areas of the Safeguard Buildings plus the entire Fuel Building) was analyzed as being part of the leakage to the annulus; this is a conservative assumption since it does not account for the holdup and decay within the safeguards and fuel buildings that can be credited due to the mixing provided by the SBVS (see RG 1.183, Appendix A, Section 4.4). The release is considered to be a ground-level release since the vent stack height does not meet the regulatory requirements to be considered an elevated release.

ESF Component Leakage Pathway

The starting point for the source term is as described above for the containment leakage pathway, and the release is initially to the containment atmosphere. The activity available for release via ESF component leakage corresponds to whatever iodines end up within the post-LOCA liquids as a result of plateout, and of their progeny (noble gases), and is time-dependent. The ESF component leakage corresponds to a fractional release rate of $9.09\text{E-}03$ per day which, when coupled with the 10 percent flashing fraction, leads to an effective fractional release rate from the IRWST that is less than the primary containment leakage (even after the 50 percent reduction at 24 hours to $1.25\text{E-}03$ per day). Therefore any increased deposition of iodines within the IRWST (through the use of higher deposition rates in the PC control volume) leads to lower overall radiological consequences (combined PC and ESF component leakage).

The source term for the atmospheric release was assumed to consist of the iodines (as specified in RG 1.183, Appendix A, Sections 5.3 and 5.5, based on 10 percent flashing of the spilled liquids), as well as of the noble gases generated within the post-LOCA liquids by the decay of halogens. This assumption implies that the noble gases generated within the IRWST (inside containment) are assumed to be retained within the liquid phase, carried over with the leaking fluid, and instantly released to the Safeguard Building atmosphere. Noble gases generated by the decay of halogens within the accumulated ESF leakage are subject to delayed release due to diffusion time through the spilled liquid layer. This delay, however, only affects the short-lived Xe-135m (i.e., the delay time is much shorter than the half-lives of Xe-133 and Xe-135). The noble gases (including Xe-135m) generated by the decay of halogens on the filters are accounted for.

The ESF component leakage corresponds to 4 gpm (twice the proposed limit, in line with RG 1.183, Appendix A, Sec. 5.2), for the accident duration of 30 days.

Releases to the atmosphere are as follows:

- During the 305-second drawdown time of the Safeguard Building and Fuel Building (by the KLC), 100 percent of the airborne source term from the ESF component leakage was assumed to be exhausted directly, without holdup, to the environment at a location adjacent to the SG 3 silencer (closest point to the MCR intakes), unfiltered.
- Following the end of drawdown, the ESF component leakage release is directly to the atmosphere via the vent stack, a ground-level release, and is filtered by the KLC, with 99 percent filtration efficiency for all species.

The receptors of interest are at the EAB, LPZ and MCR. Atmospheric dispersion factors for the EAB and LPZ are shown in Table 2.1-1. Time-shifting of the atmospheric dispersion factors was applied to all receptors of interest so that the most

adverse release of radioactive material to the environment occurs coincident with the period of most adverse atmospheric dispersion (in line with RG 1.183, Section 4.1.5, and RG 1.194, Section 2). The MCR filtered and unfiltered atmospheric dispersion factors are listed in Table 2.1-1. Table 15.0-51—MCR Composite χ/Q and Filter-Bypass Fractions LOCA Releases at the Vent Stack Base provides the MCR composite atmospheric dispersion factors and filter-bypass fractions for the LOCA. These are the χ/Q values and filter-bypass fractions that are appropriate if both the MCR supply air and unfiltered inleakage were modeled using a single junction from the environment into the MCR.

The MCR envelope ventilation model is described in Section 15.0.3.4.1. The MCR envelope is substantially shielded by the concrete structures of the Containment Building and Shield Building (including annulus). Thus, the only external shine dose explicitly calculated for the MCR is that associated with filter shine from the SAB charcoal filter. The charcoal filter is modeled as a point source located on elevation 69 feet of the MCR envelope (the HVAC space), approximately ten feet above the receptor point in the MCR proper (on elevation 53 feet), which is shielded by the approximately 20-inch (50 cm) intervening concrete floor. The HVAC space is within the MCR envelope and accounts for one third of the 200,000 ft³ volume of the MCR envelope. Direct shine from airborne radioactivity within the HVAC space to the MCR proper was neglected in view of the shielding provided by the 20-inch concrete floor.

15.0.3.11.3 Results

The U.S. EPR LOCA doses are summarized in Table 15.0-53—Radiological Consequences of U.S. EPR Design Basis Accidents (rem TEDE). The worst-case receptor is in the MCR, where the overall TEDE dose corresponds to approximately 80 percent of the limit. The MCR filter shine dose is relatively small, resulting in less than 0.1 rem, accounting for occupancy factor.

15.0.3.12 Postaccident Reactor Building Water Chemistry Control

The evaluation presented in this section determines the quantity of the buffer trisodium phosphate dodecahydrate (TSP-C) for which the pH of the IRWST water remains at a pH of 7.0 or above for 30 days following a DBA-LOCA. The source term for the evaluation follows the AST methodology.

The pH of the IRWST water is calculated considering the boric acid and TSP-C in the water, as well as the H⁺ added from radiolysis of Reactor Building materials in the post-LOCA environment. The IRWST liquid pH is a major factor in determining the amount of elemental iodine (I₂) that is re-evolved from the liquid solution. A pH value greater than 7.0 for a thirty-day period is sufficient for controlling re-evolution.

15.0.3.12.1 Sequence of Events and Systems Operations

The initial containment liquid pH used in the post-LOCA pH analysis is primarily a function of the boric acid and TSP-C concentrations in the primary system and IRWST which become mixed. The containment liquid pH decreases with the acid added from the radiolysis of containment water and electrical cable insulation. As a result, the pH analysis accounts for the post-LOCA environmental conditions that introduce other chemical species.

The strongest acids produced in the post-LOCA harsh environment are nitric acid (HNO_3) from the radiolysis of water and hydrochloric acid (HCL) from the radiolysis of chloride bearing materials. The chloride bearing materials include electrical cables with PVC or Hypalon jackets. Cesium hydroxide (CsOH) is also available at the beginning of the accident (released along with the iodine), but it is neglected for conservatism. The amount of buffer added to the containment liquid solution is based on the post-LOCA time-dependent acid concentration for a recommended period (i.e., 30-day period).

The post-LOCA evaluation addresses the radiolysis of water to calculate the HNO_3 concentration in IRWST water as a function of time. As previously noted, credit is not taken for the production of CsOH from fission product cesium. The radiolysis of cable model is used to calculate the HCl concentration in the IRWST water as a function of time. The total H^+ added to the IRWST water is calculated as a function of time by adding the contributions from HNO_3 and HCl. Organic acid from the radiolysis of organic materials dissolved from containment surface coatings in contact with the pool has been neglected, since the U.S. EPR uses LOCA-qualified inorganic containment coatings.

15.0.3.12.2 Input Parameters and Initial Conditions

The U.S. EPR post-LOCA pH evaluation follows the models in NUREG-1081 (Reference 17) and NUREG/CR-5950 (Reference 18). The model inputs are presented in Table 15.0-54—IRWST pH Analysis Inputs.

15.0.3.12.3 Results

The mass of TSP-C required to maintain the pH of the IRWST in the containment of the U.S. EPR at or above 7.0 for 30 days following a DBA-LOCA is 12,200 lbm for 100,000 lbm of Hypalon jacket and 4000 lbm of PVC cable jacketing. The H^+ time history is provided in Table 15.0-55— H^+ Added to IRWST. IRWST pH as a function of acid added is provided in Table 15.0-64—IRWST pH vs. Acid Added, and IRWST pH as a function of time is provided in Table 15.0-65—IRWST pH vs. Time.

The mass of TSP versus pH is provided in Table 15.0-56—Mass of TSP vs. pH at 30 Days. To verify the 12,200 lb_m of TSP shown on Table 15.0-56, the purity and density of the TSP-C (TSP in crystalline form) are included in the purchase specification to provide a minimum assay in accordance with Technical Specification requirements. Purchase requirements are then used to assess the vendors Certificate of Analysis (C of A). The known assay and as-purchased density are used to establish equivalency to the assumed 100 percent assay and 58 lb_m/ft³ density used for determining the volume required by the Technical Specifications.

15.0.3.13 Control Room Radiological Habitability

The MCR and TSC radiological habitability evaluation is included in Section 15.0.3.11.

15.0.4 Plant Cooldown

15.0.4.1 Post Chapter 15 Events Cooldown

The analysis of Chapter 15 events are generally terminated when the plant achieves a stable, controlled condition (i.e., the reactor is subcritical and remains subcritical, the core is covered, decay heat is being removed from the RCS, and secondary inventory levels are sufficient to maintain RCS temperatures). Subsequent actions, including cooldown, will be addressed in plant specific Emergency Operating Procedures (EOPs).

15.0.5 Compliance with Section C.I.15, “Transient and Accident Analyses,” of Regulatory Guide 1.206

Table 15.0-57—TMI Action Plan Items, Table 15.0-58—Unresolved Safety Issues, Table 15.0-59—Generic Safety Issues, Table 15.0-60—NRC Generic Letters, and Table 15.0-61—NRC Bulletins respectively present the disposition of the NRC issues listed in Section C.I.15. “Transient and Accident Analyses,” of RG 1.206, including specific TMI action plan items, unresolved safety issues (USIs), generic safety issues (GSIs), generic letters (GLs), and Bulletins (BLs).

15.0.6 References

1. NUREG-0800, “Standard Review Plan for the Review of Safety Analysis Reports for Nuclear Power Plants,” U.S. Nuclear Regulatory Commission, March 2007.
2. ANP-10287P, Revision 1, “Incore Trip Setpoint and Transient Methodology for U.S. EPR,” AREVA NP Inc., April 2012.
3. ANP-10263PA, Revision 0, “Codes and Methods Applicability Report for U.S. EPR,” AREVA NP Inc., August 2007.
4. ANP-10278P, Revision 1, “U.S. EPR Realistic Large Break Loss of Coolant Accident,” AREVA NP Inc., January 2010.

5. NUREG-0138, "Staff Discussion of Fifteen Technical Issues Listed in Attachment to November 3, 1976, Memorandum from Director NRR to NRR Staff," U.S. Nuclear Regulatory Commission.
6. Reserved.
7. Reserved.
8. ANP-10291P, Revision 0, "Small-Break LOCA and NON-LOCA Sensitivity Studies and Methodology," AREVA NP Inc., October 2007.
9. RSIC Computer Code Collection CCC-371, "ORIGEN 2.1-Isotope Generation and Depletion Code-Matrix Exponential Method," Oak Ridge National Laboratory, August 1991.
10. ORNL/TM-11018, "Standard and Extended-Burnup PWR and BWR Reactor Models for the ORIGEN-2 Computer Code," Oak Ridge National Laboratory, December 1989.
11. Regulatory Issue Summary (RIS) 2006-04, "Experience with Implementation of Alternative Source Terms," U.S. Nuclear Regulatory Commission, March 2006.
12. EPA 520/1-88-020, Federal Guidance Report No. 11, "Limiting Values of Radionuclide Intake and Air Concentration, and Dose Conversion Factors for Inhalation, Submersion, and Ingestion," U.S. Environmental Protection Agency, September 1988.
13. EPA 402-R-93-081, Federal Guidance Report No. 12, "External Exposure to Radionuclides in Air, Water, and Soil," U.S. Environmental Protection Agency, September 1993.
14. Palo Verde Nuclear Generating Station Units 1, 2 and 3, Docket Nos. 50-528, 50-529 and 50-530 -Issuance of Amendments Re: "Replacement of Steam Generators and Up-rated Power Operations and Associated Administrative Changes," NRC ADAMS Accession No. ML053130275, U.S. Nuclear Regulatory Commission, November 2005.
15. NUREG-1228, "Source Term Estimation During Incident Response to Severe Nuclear Power Plant Accidents," U.S. Nuclear Regulatory Commission, 1988.
16. NUREG/CR-6604, "RADTRAD: A Simplified Model for RADionuclide Transport and Removal and Dose Estimation," U.S. Nuclear Regulatory Commission, December 1997, and Supplements (Supp. 1, 6/1999, and Supp. 2, 10/2002).
17. NUREG-1081, "Postaccident Gas Generation from Radiolysis of Organic Materials," NRC, September 1984.
18. NUREG/CR-5950, "Iodine Evolution and pH Control," U.S. Nuclear Regulatory Commission, December 1992.

19. ANP-10266, Revision 4, "AREVA NP Inc. Quality Assurance Plan (QAP) for Design Certification of the U.S. EPR Topical Report," AREVA NP Inc., December 2012.

Table 15.0-1—U.S. EPR Initiating Events
Sheet 1 of 2

Event	Classification
15.0.3 Radioactive Release from Subsystem or Component	DBA (AOO or PA)
Failure of small line carrying primary coolant outside containment	DBA (PA)
SG tube failure	DBA (PA)
MSL failure outside containment	DBA (PA)
RCP locked rotor	DBA (PA)
RCCA ejection	DBA (PA)
Fuel handling accident	DBA (PA)
LOCA	DBA (PA)
15.1 Increase in Heat Removal By Secondary System	AOO or PA
Decrease in feedwater temperature	AOO
Increase in feedwater flow	AOO
Increase in steam flow	AOO
Inadvertent opening of SG relief or safety valve	AOO
Steam system piping failure	PA ¹
15.2 Decrease in Heat Removal By Secondary System	AOO or PA
Loss of external load	AOO
TT	AOO
Loss of condenser vacuum	AOO
Closure of MSIV	AOO
Loss of nonemergency AC power	AOO
Loss of normal feedwater flow	AOO
Feedwater system pipe break	PA ¹
15.3 Decrease in RCS Flow Rate	AOO or PA
Partial loss of forced reactor coolant flow	AOO
Complete loss of forced reactor coolant flow	AOO
RCP rotor seizure	PA
RCP shaft break	PA
15.4 Reactivity and Power Distribution Anomaly	AOO or PA
Uncontrolled RCCA withdrawal from subcritical or low power startup condition	AOO
Uncontrolled RCCA withdrawal at power	AOO

**Table 15.0-1—U.S. EPR Initiating Events
Sheet 2 of 2**

Event	Classification
Single RCCA withdrawal	AOO
RCCA misalignment	AOO
RCCA drop	AOO
Startup of RCP in inactive loop	AOO
Inadvertent decrease in boron concentration in RCS	AOO
Inadvertent loading and operation of fuel assembly in improper position	AOO
RCCA ejection	PA
15.5 Increase in RCS Inventory	AOO or PA
Inadvertent operation of ECCS or EBS	AOO
CVCS malfunction that increases reactor coolant inventory	AOO
15.6 Decrease in RCS Inventory	AOO or PA
Inadvertent opening of PSRV	AOO
SG tube failure	PA
SBLOCA	PA
LBLOCA	PA

Note:

1. Minor pipe breaks are considered AOOs.

Table 15.0-2—Accident Analysis Acceptance Criteria

Event Category	Acceptance Criteria
<p>AOO</p>	<p>Pressure in the reactor coolant and main steam systems maintained below 110% of design value.</p> <p>Fuel cladding integrity is maintained by keeping the minimum departure from nucleate boiling ratio (DNBR) above the 95/95 DNBR limit.</p> <p>FCM is precluded by limiting the maximum linear power density.</p> <p>Fuel uniform cladding strain does not exceed one percent.</p> <p>An AOO should not result in a postulated event without other faults occurring independently or result in a consequential loss of function of the RCS or reactor containment barriers.</p>
<p>PA</p>	<p>Pressure in the RCS and main steam system maintained below acceptable design limits, considering potential brittle as well as ductile failures.</p> <p>Fuel cladding integrity is maintained if the minimum DNBR remains above the 95/95 DNBR limit. If the minimum DNBR does not meet these limits, then the fuel is assumed to have failed.</p> <p>The release of radioactive material does not result in offsite doses in excess of 10 CFR 100.</p> <p>A PA does not, by itself, cause a consequential loss of function of systems needed to cope with the fault, including those of the RCS and the containment system.</p> <p>For LOCAs, the acceptance criteria of 10 CFR 50.46 also apply.</p>

Table 15.0-3—Plant Operating Modes

Mode	Title	Reactivity Condition (K_{eff})	% Rated Thermal Power ¹	Average Reactor Coolant Temperature
1	Power operation	≥ 0.99	$> 5\%$	$594^{\circ}\text{F} > T_{AVG} > 580^{\circ}\text{F}$
2	Startup	≥ 0.99	$\leq 5\%$	$580^{\circ}\text{F} > T_{AVG} > 578^{\circ}\text{F}$
3	Hot standby	< 0.99	NA	$578^{\circ}\text{F} > T > 350^{\circ}\text{F}$
4	Hot shutdown ²	< 0.99	NA	$350^{\circ}\text{F} > T > 200^{\circ}\text{F}$
5	Cold shutdown ²	< 0.99	NA	$\leq 200^{\circ}\text{F}$
6	Refueling ³	NA	NA	NA

Notes:

1. Excluding decay heat.
2. All reactor vessel head closure bolts fully tensioned.
3. One or more reactor vessel head closure bolts less than full tensioned.

Table 15.0-4—Nuclear Steam Supply System Power Levels Assumed in the Accident Analysis

Parameter Description	Power (MW_t)
Rated core thermal power	4590
Effective thermal power generated by the RCPs	30
Uncertainty on secondary system heat balance	22
Maximum NSSS thermal power output	4642

Table 15.0-5—Plant Parameters Used in Accident Analyses

Plant Parameter	Nominal Value at Rated Thermal Power	Range Considered ¹
Core power	4590 MW _t	0 to 4590 MW _t
T _{AVG}	594°F	594°F ³
Reactor coolant system pressure	2250.0 psia	2250.0 psia ⁸
Pressurizer liquid level	54.3% of span	34 to 54.3% of span ⁶
Reactor coolant flow per loop	119,692 gpm ⁴	119,692 gpm ⁵
Steam generator level	49% of narrow range span	49% of narrow range span ⁷
Steam generator tube plugging level	0%	0 to 5%
Assumed feedwater temperature at steam generator inlet	446°F ²	446°F ²

Notes:

1. Not including uncertainties or operating band.
2. Feedwater temperature for cases with all feedwater heaters in service. For cases with one string of feedwater heaters out of service a temperature of 381°F was assumed.
3. For mode 1, T_{AVG} is a function of power and is based on Figure 4.4-7—Average RCS Temperature vs. Core Power, ±3°F for uncertainty and 1°F for operating band. In addition, end of cycle (EOC) -10°F is included for a full power coastdown.
4. Represents reactor coolant system Thermal Design Flow or minimum RCS flow.
5. In accordance with the applicable approved methodology (Reference 3).
6. Pressurizer level is a function of the volume and temperature of three (hot, average, and cold) RCS regions. The nominal steady state full power level is 54.3% and the hot zero power pressurizer level is ~37.4%. The pressurizer level has ±5% for uncertainty and operating band.
7. Steam generator level is constant as a function of power, ±6% for uncertainty and operating band.
8. Pressurizer pressure is constant at 2250 psia, ±50 psia for uncertainty and operating band.

Table 15.0-6—Reactivity Coefficients, Scram Reactivity, and Computer Codes
Sheet 1 of 5

Transient	Computer Codes Used	Reactivity Coefficients for the Transient			Scram Reactivity (pcm)	
		Moderator Temperature (pcm/°F)		Fuel Temperature (pcm/°F)		
15.1 Increase in Heat Removal By Secondary System						
Decrease in feedwater temperature	S-RELAP5	BOC	0	BOC	-1.26	-6161
	LYNX ^{T1}	EOC	-50	EOC	-1.51	-7353
Increase in feedwater flow	S-RELAP5	HFP: BOC	0	BOC	-1.26	-6161
		EOC	-50	EOC	-1.51	-7353
	60% power:	BOC	0			-5964
		EOC	-42			-7068
	25% power:	BOC	5.73			-5698
		EOC	-42			-6643
HZP: EOC	-30				-6049	
Increase in steam flow	S-RELAP5	HFP: BOC	0	BOC	-1.26	-6161
		EOC	-50	EOC	-1.51	-7353
	25% power:	BOC	5.73			-5698
		EOC	-42			-6643
	HZP: EOC	-30				-6049
Inadvertent opening of a SG relief or safety valve	S-RELAP5	HFP: BOC	0	BOC	-1.26	-6161
		EOC	-50	EOC	-1.51	-7353
	25% power:	BOC	5.73			-5698
		EOC	-42			-6643
	HZP: EOC	-30				-6049

Table 15.0-6—Reactivity Coefficients, Scram Reactivity, and Computer Codes
Sheet 2 of 5

Transient	Computer Codes Used	Reactivity Coefficients for the Transient		Scram Reactivity (pcm)
		Moderator Temperature (pcm/°F)	Fuel Temperature (pcm/°F)	
Steam system piping failure	S-RELAP5 LYNXT ² PRISM	Moderator density defect corresponding to EOC -50	Defect corresponding to EOC -1.64	-3000
15.2 Decrease in Heat Removal By Secondary System				
Turbine trip	S-RELAP5 LYNXT ¹	0	-1.17	-6161
Closure of a MSIV	S-RELAP5 LYNXT ¹	-50	-1.848	-7353
Loss of non-emergency AC power	S-RELAP5	0	-1.17	-6161
Loss of normal feedwater flow	S-RELAP5	BOC 0 EOC -31.41	BOC -1.17 EOC -1.47	-6161
Feedwater system pipe break	S-RELAP5	0	-1.17	-6161
15.3 Decrease in RCS Flow Rate				
Partial loss of forced reactor coolant flow	S-RELAP5 NEMO-K LYNXT	0	-1.17	-6161
Complete loss of forced reactor coolant flow	S-RELAP5 NEMO-K LYNXT	0	-1.17	-6161
RCP rotor seizure	S-RELAP5 NEMO-K LYNXT	0	-1.17	-6161

Table 15.0-6—Reactivity Coefficients, Scram Reactivity, and Computer Codes
Sheet 3 of 5

Transient	Computer Codes Used	Reactivity Coefficients for the Transient				Scram Reactivity (pcm)	
		Moderator Temperature (pcm/°F)		Fuel Temperature (pcm/°F)			
15.4 Reactivity and Power Distribution Anomaly							
Uncontrolled RCCA bank withdrawal from a subcritical or low power startup condition	S-RELAP5 LYNXT	5.73		-1.17		-3000	
Uncontrolled RCCA bank withdrawal at power	S-RELAP5 LYNXT ¹	>60% power:	BOC	0	BOC	-1.17	HFP -6161 60% -5964 25% -5698
			EOC	-50	EOC	-1.85	
		60% power:	BOC	0			
			EOC	-42			
Single RCCA withdrawal	S-RELAP5 LYNXT ¹	>60% power:	BOC	0	BOC	-1.17	HFP -6161 60% -5964 25% -5698
			EOC	-50	EOC	-1.85	
		60% power:	BOC	0			
			EOC	-42			
RCCA misalignment	LYNXT ¹	<50% power:	BOC	5.73			NA
			EOC	-42			
		NA		NA			
		NA		NA			
RCCA drop	S-RELAP5 LYNXT ¹	BOC	0	BOC	-1.17	-6161	
		EOC	-50	EOC	-1.85		
Startup of a RCP in an inactive loop	S-RELAP5 LYNXT	-42		-1.51		NA	

Table 15.0-6—Reactivity Coefficients, Scram Reactivity, and Computer Codes
Sheet 4 of 5

Transient	Computer Codes Used	Reactivity Coefficients for the Transient				Scram Reactivity (pcm)	
		Moderator Temperature (pcm/°F)		Fuel Temperature (pcm/°F)			
Inadvertent decrease in the boron concentration in the RCS	S-RELAP (at power)	>60% power:	BOC	0	BOC	-1.17	HFP -6161 60% -5964 25% -5698
			EOC	-50	EOC	-1.85	
		60% power:	BOC	0			
			EOC	-42			
		<50% power:	BOC	5.73			
			EOC	-42			
Inadvertent loading and operation of a fuel assembly in an improper position	PRISM LYNXT ¹	NA		NA		NA	
RCCA ejection	S-RELAP5 NEMO-K LYNXT	>50% power		-1.17		HFP -6161	
						60% -5964	
		<50% power		5.73		25% -5698	
						HZP -3000	
15.5 Increase in RCS Inventory							
Inadvertent operation of the ECCS or EBS	S-RELAP5	BOC		-1.17		-6161	
		EOC		-1.467			
CVCS malfunction that increases reactor coolant inventory	S-RELAP5	BOC		-1.17		-6161	
		EOC		-1.467			

Table 15.0-6—Reactivity Coefficients, Scram Reactivity, and Computer Codes
Sheet 5 of 5

Transient	Computer Codes Used	Reactivity Coefficients for the Transient		Scram Reactivity (pcm)
		Moderator Temperature (pcm/°F)	Fuel Temperature (pcm/°F)	
15.6 Decrease in RCS Inventory				
Inadvertent opening of a pressurizer relief valve	S-RELAP5 LYNXT ¹	Moderator density defect corresponding to BOC 0 EOC -50	BOC -1.17 EOC -1.467	-6161
SGTR	S-RELAP5	Moderator density defect corresponding to most-negative BOC	Defect corresponding to 10% less negative than least-negative BOC	-6161
Small-break loss-of-coolant accident	S-RELAP5	NA	NA	-6161
Realistic large-break loss-of-coolant accident	S-RELAP5	Moderator density defect corresponding to nominal BOC	Defect corresponding to nominal BOC	NA

Notes:

1. See Section .
2. See Section for pre-scram; post-scram MSLB uses LYNXT directly.

Table 15.0-7—Reactor Trip Setpoints and Delays Used in the Accident Analysis
Sheet 1 of 2

Signal ⁴	Setpoint ¹ (Nominal)	Uncertainty (Normal/Degraded)	Time Delay ² (s)
Pressurizer pressure < Min2p	2005.0 psia	25 psi/55 psi	1.3
Pressurizer pressure > Max2p	2414.7 psia	25 psi/55 psi	1.3
Pressurizer level > Max1p	75%	5.5%/8.0%	1.9
Hot leg pressure < Min1p	2005.0 psia	45 psi / (75 psi < 15 sec, 110 psi > 15 sec)	1.3
SG pressure < Min1p	724.7 psia	30 psi/75 psi	1.3
SG pressure > Max1p	1384.7 psia	30 psi/75 psi	1.3
SG ΔP > Max1p	see note 7	30 psi/75 psi	1.3
SG level < Min1p	20% NR ³	5%/19%	1.9
SG level > Max1p	69% NR	9.5%/11.5%	1.9
High containment pressure	see note 5	see note 5	see note 5
High linear power density as a function of detected SPND failures	0,1 - 460 W/cm 2,3 - 445 W/cm 4,5 - 440 W/cm	see note 8	1.0
Low DNBR as a function of detected SPND string failures	0 - 2.30 1 - 2.35 2 - 2.40 3 - 2.45 4 - 2.50	see note 8	1.4 plus sensor delays
Low DNBR _{Imb/Rod Drop} as a function of detected SPND string failures	0 - 2.35 1 - 2.40 2 - 2.50 3 - 2.55 4 - 2.60	see note 8	1.4 plus sensor delays
Low DNBR _{Rod Drop} as a function of detected SPND string failures	0 - 2.35 1 - 2.40 2 - 2.50 3 - 2.55 4 - 2.60	see note 8	1.4 plus sensor delays
Low DNBR _{High Quality}	25% ⁹	see note 8	1.4 plus sensor delays
Low DNBR _{High Quality Imb/Rod Drop}	20% ⁹	see note 8	1.4 plus sensor delays
Low saturation margin ⁶	see note 6	see note 6	see note 6
Excure high neutron flux rate of change	11% NP	2% NP	0.7

**Table 15.0-7—Reactor Trip Setpoints and Delays Used in the Accident Analysis
Sheet 2 of 2**

Signal ⁴	Setpoint ¹ (Nominal)	Uncertainty (Normal/Degraded)	Time Delay ² (s)
High core power level	105% NP	10.2% NP/11.7% NP	0.9 plus sensor delays
Low RCS flow rate (2 loops)	90% NF	4% NF	1.05
Low-low RCS flow rate (one loop)	54% NF	4% NF	1.05
Low RCP speed (2 loops)	93% NS	1% NS	0.75
High neutron flux (IR)	25% NP	10% NP	0.7
Low neutron flux doubling time (IR)	20 s	10 s	0.7

Notes:

- The value assumed in the accident analysis (i.e., the analytical limit) is the nominal setpoint (listed in this column) plus or minus the uncertainty (listed in the next column).
NP - Nominal power - it should be noted that other terms are also used to depict reactor power, thermal power, rated thermal power, etc. Under steady-state conditions, these are equivalent.
NF - Nominal flow
NS - Nominal speed
NR - Narrow range
- For RT functions the time delay is from the time the value is sensed at the sensor until the stationary gripper releases. It includes sensor delay, I&C delay, and the delay for the trip breakers to open and the stationary gripper to release. Once the stationary gripper releases the control rods drop into the core. It is assumed that the control rods take an additional 3.5 seconds to completely insert (Figure 15.0-1).
- FWLB has conservatively assumed a setpoint of 0% NR.
- A TT is credited following an RT. The DCS is designed to issue the trip signal to the turbine generator I&C system after a one-second delay.
- The DCS includes an RT on high containment pressure. This trip is not credited in the analysis presented in this section; however, it is credited in the containment analysis presented in Chapter 6.
- This safety-related signal was not explicitly credited in the safety analyses. An RT on low saturation margin is introduced because, in case of saturation occurring in a hot leg, the thermal core power level calculation becomes invalid.
- The pressure setpoint is variable and tracks the steam line pressure with a constant offset (102 psi). The setpoint has a limitation on its maximum pressure (1087.7

psia) and its maximum rate of decrease (29 psi/min). If the steamline pressure decreases more rapidly than the allowable rate, then the margin between the actual pressure and the setpoint decreases until the steam line pressure is less than the setpoint generating an RT.

8. The uncertainty related to this RT function is discussed in Reference 2.
9. The high quality setpoints have the same value for 0 through 4 detected SPND string failures.

**Table 15.0-8—Engineered Safety Features Actuation System (ESFAS)
Functions Used in the Accident Analysis
Sheet 1 of 4**

Function	Setpoint	Uncertainty (Normal/ Degraded)	Time Delay (seconds) ⁴
Safety Injection System Actuation			
SIS actuation on pressurizer pressure < Min3p	1667.9 psia	25 psi/55 psi	16.5 w/o LOOP for SI delivery or 41.5 with LOOP (includes EDG loading)
SIS actuation on RCS Hot Leg ΔP_{sat} < Min1p	220 psi	110 psi/181 psi	Sensor delays plus 15.5 w/o LOOP for SI delivery or 40.5 with LOOP (includes EDG loading)
SIS actuation on RCS Loop Level < Min1p	18.9 inches	1.1 inch/2.0 inch	16.5 w/o LOOP for SI delivery or 41.5 with LOOP includes EDG loading
Emergency Feedwater System Actuation^{3, 15}			
EFWS actuation on SG Level < Min2p (WR) (affected SG)	40% WR	2%/16.5%	16.5 w/o LOOP for EFW delivery or 61.5 with LOOP (includes EDG loading)
EFWS actuation on LOOP + SIS Actuation ¹	See note 1	See note 1	60 with LOOP (includes EDG loading)
SG blowdown isolation (affected SG) ¹⁶	40% WR	2%/16.5%	21.5 (includes valve closure)
EFW level control	82.2% WR	8%/9%	Not Applicable
EFWS pump overflow protection	490 gpm max (See Note 15)	Not Applicable	N/A
Emergency Feedwater System Isolation			
EFWS isolation on SG Level > Max1p (WR) (affected SG)	89% WR ¹¹	8%/9%	61.5 (includes valve closure)
SG Isolation Signal	See SG Isolation function below		
Partial Cooldown Actuation			

**Table 15.0-8—Engineered Safety Features Actuation System (ESFAS)
Functions Used in the Accident Analysis
Sheet 2 of 4**

Function	Setpoint	Uncertainty (Normal/ Degraded)	Time Delay (seconds) ⁴
SIS Actuation Signal generated	See note 9	See note 9	See note 9
MSRT Actuation			
MSRT opening (MSRIV) on SG Pressure > Max1p (affected SG)	1384.7 psia	30 psi/75 psi	2.7 (includes valve opening)
MSRT isolation (MSRIV,MSRCV) on SG Pressure < Min3p (affected SG)	579.7 psia	30 psi/75 psi	5.9 (includes closing time for MSRIV)
Main Steam Isolation			
MSIV closure on SG pressure drop > Max1p (all SGs)	See note 13	30 psi/75 psi	5.9 (includes valve closure)
MSIV closure on SG pressure < Min1p (all SGs)	724.7 psia	30 psi/75 psi	0.9 plus 5 for valve closure
MSIV closure on High Containment pressure	See Containment Isolation function below		
SG Isolation Signal	See SG Isolation function below		
Main Feedwater Isolation			
MFW full load isolation on Reactor Trip (all SGs)	Not Applicable	Not Applicable	Following TT, 40 (includes control valve closure)
MFW full load isolation on SG Level > Max1p (NR) (affected SG) ¹⁰	69% NR	9.5%/11.5%	41.5 (includes control valve closure)
MFW SSS isolation on SG Level > Max0p (NR) for period of time (affected SG)	65% NR for 10 sec w RT	9.5%/11.5%	21.5 (includes valve closure)
MFW SSS isolation on SG pressure drop > Max2p (affected SG)	See note 14	30 psi/75 psi	20.9 (includes valve closure)
MFW SSS isolation on SG pressure < Min2p (affected SG)	579.7 psia	30 psi/75 psi	20.9(includes valve closure)
MFW SSS isolation on High Containment pressure	See Containment Isolation function below		
SG Isolation Signal	See SG Isolation function below		

**Table 15.0-8—Engineered Safety Features Actuation System (ESFAS)
Functions Used in the Accident Analysis
Sheet 3 of 4**

Function	Setpoint	Uncertainty (Normal/ Degraded)	Time Delay (seconds) ⁴
Containment Isolation			
Containment equipment compartment pressure > Max1p (Stage 1)	18.7 psia	0.5 psi	See Section 6.2.4
Containment service compartment pressure (NR) > Max2p (Stage 1)	18.7 psia	0.5 psi	See Section 6.2.4
Containment activity > Max1p (Stage 1)	100 X background	Not applicable	10
SIS Actuation Signal (Stage 1)	Not applicable	Not applicable	Not applicable
Containment service compartment pressure (WR) > Max3p (Stages 1 & 2)	36.3 psia	Not applicable	See Section 6.2.4
CVCS Charging Isolation			
CVCS charging line isolation on pressurizer level > Max2p	80%	5.5%/8.0%	41.5 (includes valve closure)
CVCS Isolation for Anti-Dilution			
Anti-Dilution (power)	See note 5	See note 8	106 (includes valve closure)
Anti-Dilution (shutdown)	See note 5	See note 8	106 (includes valve closure)
Anti-Dilution (shutdown no RCPs)	927 ppm	See note 7	106 (includes valve closure)
Steam Generator Isolation			
MSRT Setpoint Increase on SG Level > Max2p + partial cooldown initiated (affected SG)	85% NR ¹¹ (1435.5 psia)	9.5%/11.5% (30 psi / 75 psi)	1.5
MSRT setpoint increase on high steam line activity + partial cooldown initiated (affected SG) ²	See note 2 (1435.5 psia)	See note 2 (30 psi/75 psi)	See note 2.
MSIV closure on SG level > Max2p (NR) + partial cooldown Initiated (affected SG)	85% NR ¹¹	9.5%/11.5%	6.5 (includes valve closure)
MSIV closure on high steam line activity + partial cooldown initiated (affected SG) ²	See note 2.	See note 2.	See note 2.
MFW SSS Isolation on SG Level > Max2p (NR) + partial cooldown initiated (affected SG)	85% NR ¹¹	9.5%/11.5%	21.5 (includes valve closure)

**Table 15.0-8—Engineered Safety Features Actuation System (ESFAS)
Functions Used in the Accident Analysis
Sheet 4 of 4**

Function	Setpoint	Uncertainty (Normal/Degraded)	Time Delay (seconds) ⁴
MFW SSS isolation on high steam line activity + partial cooldown initiated (affected SG) ²	See note 2	See note 2	See note 2
EFWS isolation on SG Level (NR) > Max2p + partial cooldown initiated (affected SG)	85% NR ¹¹	9.5%/11.5%	61.5 (includes valve closure)
EFWS isolation on High Steam Line Activity + partial cooldown initiated (affected SG) ²	See note 2.	See note 2.	See note 2.
Reactor Coolant Pump Trip			
RCP Trip on ΔP Over RCP < Min1p + SIS Signal	80% nominal	3%/5%	3.9 ¹²
MCR AC System Isolation			
MCR air intake activity > Max1p	3 X background	Not applicable	60
Turbine Trip on RT			
Initiation of RT	Following RT	Not Applicable	1.0 (DCS is designed to issue TT 1 second after RT)
EDG on LOOP or degraded voltage¹⁷			
EBS			
EBS Isolation	Manual	Not Applicable	Not Applicable
Hydrogen Mixing Dampers Opening			
Containment service compartment pressure (NR) > Max1p	17.4 psia	± 0.5 psia	18 (includes damper opening)
Containment equipment compartment/containment service compartment ΔP > Max1p	0.5 psi	$\pm 30\%$	18 (includes damper opening)

Notes:

1. EFWS actuation on LOOP and SIS is assumed in the SGTR to minimize the margin to overfill. It is also credited in SBLOCA. This function does not have a specific setpoint, uncertainty, or delay.
2. The accident analysis does not credit automatic actions based on MSL activity but uses MSL activity for input to operator action. This function does not have a specific setpoint, uncertainty, or delay.

3. EFWS actuation also results in SG blowdown isolation.
4. Represents the total time for completion of the function. Includes sensor delay, I&C delay (includes DCS computerized portion, and PACS delays), and other delays as noted until the function is completed.
5. The setpoints for the anti-dilution protection function vary as a function of core burnup and are specified in the Core Operating Limits Report.
6. Intentionally left blank.
7. A bounding uncertainty of 400 ppm is used.
8. Varies with boron concentration.
9. The partial cooldown actuation signal is initiated on the SIS signal and therefore does not have a specific setpoint, uncertainty, or delay.
10. MFW is isolated in two steps. First is the full load and the second is isolation of the startup and shutdown system (SSS).
11. These SGTR mitigation features are credited in the accident analysis as manual operator actions.
12. Three seconds of the 3.9-second delay is associated with the bus supply breaker delay. This feature results in an RCP trip.
13. The pressure setpoint is variable and tracks the steam line pressure with a constant offset (102 psi). The setpoint has a limitation on its maximum pressure (1087.7 psia) and its maximum rate of decrease (29 psi/min). If the steamline pressure decreases more rapidly than the allowable rate, then the margin between the actual pressure and the setpoint decreases until the steam line pressure is less than the setpoint generating an MSIV closure.
14. The pressure setpoint is variable and tracks the steam line pressure with a constant offset (247 psi). The setpoint has a limitation on its maximum pressure (942.7 psia) and its maximum rate of decrease (29 psi/min). If the steamline pressure decreases more rapidly than the allowable rate, then the margin between the actual pressure and the setpoint decreases until the steam line pressure is less than the setpoint generating an MFW SSS isolation.
15. The MSLB analysis assumes a maximum flow to a depressurized SG of 572 gpm.
16. SG blowdown isolation is not a separate function but part of the EFWS actuation function.
17. The safety analysis credits the EDGs for scenarios with LOOP.

Table 15.0-9—Pressurizer and Secondary Safety Relief Valve Settings Used in the Accident Analysis

Pressurizer Relief	Nominal Setpoint	Uncertainty	Capacity	Blowdown
PSRV1	2535 psig ¹	+/- 2%	661,400 lb/hr @ 2535 psig	6%
PSRV2	2535 psig	+/- 2%	661,400 lb/hr @ 2535 psig	6%
PSRV3	2535 psig	+/- 2%	661,400 lb/hr @ 2535 psig	6%
Secondary Relief	Nominal Setpoint	Uncertainty	Capacity	Blowdown
MSRT ² (1 per loop)	1370 psig	30 psig/75 psig	2,844,146 lb/hr @ 1370 psig	See Note 3
MSSV1 (1 per loop)	1460 psig	+/- 3%	1,422,073 lb/hr @ 1.03*1460 psig	6%
MSSV2 (1 per loop)	1490 psig	+/- 3%	1,422,073 lb/hr @ 1.03*1490 psig	6%

Notes:

1. The accident analysis assumes that the PSRVs open at a pressure of 2535 psig +/- 2% with an opening time of 0.7 seconds.
2. The accident analysis assumes that the MSRV opens at 1370 psig +/- 30 psig (75 psig where applicable) with an opening time of 1.8 seconds.
3. The accident analysis assumes that the MSRV closes at 565 psig +/- 30 psig (75 psig where applicable) with a closing time of 5.0 seconds.

Table 15.0-10—Plant Systems Used in the Accident Analysis
Sheet 1 of 4

Incident	Reactor Trip Functions ¹	ESF Functions ²	Other Equipment
15.1 Increase in Heat Removal by Secondary System			
Decrease in feedwater temperature	<ul style="list-style-type: none"> ● Low DNBR ● High LPD 		PSRVs
Increase in feedwater flow	<ul style="list-style-type: none"> ● High SG level ● Low DNBR ● High LPD 		
Increase in steam flow	<ul style="list-style-type: none"> ● Low DNBR ● High LPD ● Low SG pressure ● High SG ΔP 	<ul style="list-style-type: none"> ● MFW/SSS isolation on low SG pressure or high SG ΔP ● SIS and partial cooldown on low RCS pressure ● MSIV closure on low SG pressure or high SG ΔP 	
Inadvertent opening of a SG relief or safety valve	<ul style="list-style-type: none"> ● Low DNBR ● High LPD ● Low SG pressure ● High SG ΔP 	<ul style="list-style-type: none"> ● MFW/SSS isolation on low SG pressure or high SG ΔP ● SIS and partial cooldown on low RCS pressure ● MSRT isolation on low SG pressure ● MSIV closure on low SG pressure or high SG ΔP 	

Table 15.0-10—Plant Systems Used in the Accident Analysis
Sheet 2 of 4

Incident	Reactor Trip Functions ¹	ESF Functions ²	Other Equipment
Steam system piping failure	<ul style="list-style-type: none"> ● Low SG pressure ● High SG ΔP 	<ul style="list-style-type: none"> ● MSIVs closure on high SG ΔP or low SG pressure ● Affected SG MFW/SSS isolation on high-high SG ΔP or low-low SG pressure ● Unaffected SG MSRTs opening on high SG pressures ● Stuck-open-MSRCV MSRT isolation on low-low SG pressure ● SIS and partial cooldown on low-low PZR pressure, or SIS on low margin to RCS saturation 	
15.2 Decrease in Heat Removal by Secondary System			
TT	<ul style="list-style-type: none"> ● High PZR pressure 	<ul style="list-style-type: none"> ● MSRTs on high SG pressure 	PSRVs
Closure of a MSIV	<ul style="list-style-type: none"> ● Low DNBR ● High SG pressure 	<ul style="list-style-type: none"> ● MSRTs on high SG pressure 	MSSVs
Loss of non-emergency AC power	<ul style="list-style-type: none"> ● Low RCP speed ● Low RCS flow (2 loops) 	<ul style="list-style-type: none"> ● EFWS on low SG level ● MSRTs on high SG pressure 	PSRVs
Loss of normal feedwater flow	<ul style="list-style-type: none"> ● Low SG level 	<ul style="list-style-type: none"> ● EFWS on low SG level 	PSRVs
Feedwater system pipe break	<ul style="list-style-type: none"> ● Low SG pressure ● High SG ΔP ● Low SG Level ● High PZR pressure 	<ul style="list-style-type: none"> ● EFWS on low SG level ● MSIV closure on low SG pressure or high SG ΔP ● MFW/SSS isolation on low SG pressure or high SG ΔP 	PSRVs MSSVs

Table 15.0-10—Plant Systems Used in the Accident Analysis
Sheet 3 of 4

Incident	Reactor Trip Functions ¹	ESF Functions ²	Other Equipment
15.3 Decrease in Reactor Coolant System Flow Rate			
Partial loss of forced reactor coolant flow	<ul style="list-style-type: none"> ● Low RCP speed ● Low-low RCS flow (1 loop) ● Low RCS flow (2 loops) 		PSRVs
Complete loss of forced reactor coolant flow	<ul style="list-style-type: none"> ● Low RCP speed ● Low RCS flow (2 loops) 		PSRVs
RCP rotor seizure	<ul style="list-style-type: none"> ● Low-low RCS flow (1 loop). 		PSRVs
RCP shaft break	<ul style="list-style-type: none"> ● Low-low RCS flow (1 loop) 		PSRVs
15.4 Reactivity and Power Distribution Anomaly			
Uncontrolled RCCA bank withdrawal from a subcritical or low power startup condition	<ul style="list-style-type: none"> ● High flux rate (PR) ● Low doubling time (IR) ● High neutron flux (IR) 		
Uncontrolled RCCA bank withdrawal at power	<ul style="list-style-type: none"> ● Low DNBR ● High LPD ● High core power ● High flux rate (PR) ● High PZR level ● High SG pressure 		
Single RCCA withdrawal	<ul style="list-style-type: none"> ● Low DNBR 		
RCCA misalignment	<ul style="list-style-type: none"> ● Low DNBR 		
RCCA drop	<ul style="list-style-type: none"> ● Low DNBR 		
Startup of a RCP in an inactive loop	NA		
Inadvertent decrease in the boron concentration in the RCS	<ul style="list-style-type: none"> ● Low DNBR ● High core power ● High CPD ● High PZR level 		Anti-dilution
Inadvertent loading and operation of a fuel assembly in an improper position	NA		

Table 15.0-10—Plant Systems Used in the Accident Analysis
Sheet 4 of 4

Incident	Reactor Trip Functions ¹	ESF Functions ²	Other Equipment
RCCA ejection	<ul style="list-style-type: none"> ● High flux rate (PR) ● High flux (IR) ● Low doubling time (IR) ● Low PZR pressure ● Low saturation margin ● High SG pressure ● Low DNBR 		
15.5 Increase in RCS Inventory			
Inadvertent operation of the ECCS or EBS	<ul style="list-style-type: none"> ● High PZR level ● High PZR pressure 	<ul style="list-style-type: none"> ● MSRTs on high SG pressure 	PSRVs on PZR pressure
CVCS malfunction that increases reactor coolant inventory	<ul style="list-style-type: none"> ● High PZR level ● High PZR pressure 	<ul style="list-style-type: none"> ● CVCS isolation on PZR level ● MSRT on high SG pressure 	PSRVs on PZR pressure
15.6 Decrease in RCS Inventory			
Inadvertent opening of a pressurizer relief valve	<ul style="list-style-type: none"> ● Low PZR pressure ● Low DNBR 	<ul style="list-style-type: none"> ● SIS/partial cooldown on low RCS pressure ● Containment isolation 	RCP trip
SGTR	<ul style="list-style-type: none"> ● Low PZR pressure ● High PZR pressure ● High SG pressure 	<ul style="list-style-type: none"> ● SIS/partial cooldown CS pressure ● MSRTs on high SG pressure 	EBS EFW level control
Loss-of-coolant accident	<ul style="list-style-type: none"> ● Low PZR pressure ● Low Hot Leg Pressure 	<ul style="list-style-type: none"> ● SIS/partial cooldown on low RCS pressure ● Containment isolation ● MSRTs on high SG pressure ● EFWS on SG Level 	RCP trip

Notes:

1. An RT results in a TT and full load MFW isolation.
2. MSRTs are used in each event for long-term decay heat removal once the plant has achieved a stable condition.

Table 15.0-11—Single Failures Assumed in the Accident Analysis
Sheet 1 of 5

Event	Failure	Justification
15.1 Increase in Heat Removal by Secondary System		
Decrease in feedwater temperature	One protection division	There is no single failure which will make this event more severe. A failure of a DCS division is inconsequential. The DCS is single-failure proof due to its redundancy.
Increase in feedwater flow	Failure of an HL isolation valve	A failure of the HL isolation valve is inconsequential. The SG feedwater supply is isolated using the MFW isolation valve on high SG level which is upstream of the HL isolation valve and is designed single-failure proof.
Increase in steam flow	One protection division	There is no single failure which will make this event more severe. A failure of a DCS division is inconsequential. The DCS is single-failure proof due to its redundancy.
Inadvertent opening of a SG relief or safety valve	One MSRCV fails to close	The MSRCV fails to close, which makes the event more severe. For the inadvertent opening of an MSRIV, the failed MSRCV is in the associated MSRT, which causes the event to continue. For the inadvertent opening of a MSSV, the failed MSRCV is associated with another SG.
Steam system piping failure	One MSRCV fails open	An MSRCV fails in the open position in one of the unaffected main steam lines. This failure causes the SG to depressurize more than it would otherwise. This exacerbates the RCS cooldown and represents a worst case single failure.
15.2 Decrease in Heat Removal by Secondary System		
TT	One MSRT fails to open	Failure of an MSRT raises the peak RCS pressure and makes the event more severe for overpressurization.
Closure of a MSIV	One MSRT fails to open	Failure of an MSRT raises the peak SG pressure and makes the event more severe for overpressurization.

Table 15.0-11—Single Failures Assumed in the Accident Analysis
Sheet 2 of 5

Event	Failure	Justification
Loss of nonemergency AC power	One EFW train	EFW train failure limits the heat removal capacity of the EFW system and makes the event more severe.
Loss of normal feedwater flow	One EFW train	EFW train failure limits the heat removal capacity of the EFW system and makes the event more severe.
Feedwater system pipe break	One EFW train One MSRT fails to open	EFW train failure limits the heat removal capacity of the EFW system and makes the event more severe for RCS overpressurization. Inoperability of one MSRT raises the peak SG pressure and makes the event more severe for SG overpressurization.
15.3 Decrease in Reactor Coolant System Flow Rate		
Partial loss of forced reactor coolant flow	One protection division	There is no single failure which will make this event more severe. A failure of a DCS division is inconsequential. The DCS is single-failure proof due to its redundancy.
Complete loss of forced reactor coolant flow	One protection division	There is no single failure which will make this event more severe. A failure of a DCS division is inconsequential. The DCS is single-failure proof due to its redundancy.
RCP rotor seizure	One protection division	There is no single failure which will make this event more severe. A failure of a DCS division is inconsequential. The DCS is single-failure proof due to its redundancy.
15.4 Reactivity and Power Distribution Anomaly		
Uncontrolled RCCA withdrawal from a subcritical or low power startup condition	One protection division	There is no single failure which will make this event more severe. A failure of a DCS division is inconsequential. The DCS is single-failure proof due to its redundancy.

Table 15.0-11—Single Failures Assumed in the Accident Analysis
Sheet 3 of 5

Event	Failure	Justification
Uncontrolled RCCA bank withdrawal at power	One protection division	There is no single failure which will make this event more severe. A failure of a DCS division is inconsequential. The DCS is single-failure proof due to its redundancy.
Single RCCA withdrawal	One protection division	There is no single failure which will make this event more severe. A failure of a DCS division is inconsequential. The DCS is single-failure proof due to its redundancy.
RCCA misalignment	One protection division	There is no single failure which will make this event more severe. A failure of a DCS division is inconsequential. The DCS is single-failure proof due to its redundancy.
RCCA drop	Failure of highest excore signal input to CRDCS	The signal from the least shadowed, highest reading excore detector is ignored. The shadowing factor from the 2 nd least shadowed detector is conservatively applied for the response of the average coolant temperature (ACT) control function.
Startup of a RCP in an inactive loop	No protection features are challenged	There is no single failure that makes this event more severe.
Decrease in the boron concentration in the RCS	One protection division	There is no single failure which will make this event more severe. A failure of a DCS division is inconsequential. The DCS is single-failure proof due to its redundancy.
Inadvertent loading and operation of a fuel assembly in an improper position	No protection features are challenged	There is no single failure that makes this event more severe.
RCCA ejection	One protection division	There is no single failure which will make this event more severe. A failure of a DCS division is inconsequential. The DCS is single-failure proof due to its redundancy.

Table 15.0-11—Single Failures Assumed in the Accident Analysis
Sheet 4 of 5

Event	Failure	Justification
15.5 Increase in RCS Inventory		
Inadvertent operation of the ECCS or EBS	Closure of one MSRCV when MSRIV opens	Charging flow, if operational, is automatically isolated on RT with LOOP or at high PZR level for an RT with no LOOP. SI and EFW are not actuated for this event. After RT, the MSRTs open to relieve SG pressure and this enhances primary system to secondary system heat transfer. Failure of one MSRT: closure of one MSRCV when MSRIV opens, is the most limiting single failure.
CVCS malfunction that increases reactor coolant inventory	Closure of one MSRCV when MSRIV opens	Charging flow is automatically isolated on RT with LOOP or at high PZR level for an RT with no LOOP. SI and EFW are not actuated for this event. After RT, the MSRTs open to relieve SG pressure and this enhances primary to secondary heat transfer. Failure of one MSRT: closure of one MSRCV when MSRIV opens, is the most limiting single failure.
15.6 Decrease in RCS Inventory		
Inadvertent opening of a pressurizer relief valve	One EDG (1 train of SI)	One train of SIS does not operate because an EDG is assumed to fail. This failure further decreases the RCS inventory and pressure, thus making the event more severe.
SGTR	MSRT stuck open/Main feedwater full load isolation valve (MFWFLIV) fails to close	Radiological: the limiting single failure is that the MSRCV sticks fully open in the affected SG. Results in greater offsite releases. Overfill: the limiting single failure is that the MFWFLIV for the affected SG fails to close. Continued MFW contributes towards affected SG filling.

Table 15.0-11—Single Failures Assumed in the Accident Analysis
Sheet 5 of 5

Event	Failure	Justification
Loss-of-coolant accident	One EDG (1 train of SI)	<p>RLBLOCA: The most limiting active single failure is the one that results in the minimum ECCS flow delivered to the RCS. This active failure is the loss of one train of pumped ECCS injection, which includes MHSI and LHSI. Sensitivity studies performed using the 3- and 4-loop sample problems determined that the worst single failure was the loss of one EDG without the loss of containment spray or fan coolers. This becomes just a loss of one train of ECCS pumped safety injection.</p> <p>SBLOCA: The most limiting active single failure is the one that results in the minimum ECCS flow delivered to the RCS. This active failure is the loss of one EDG at the time of LOOP. Thus, one ECCS train (1MHSI+1LHSI/RHR+1EFW) is unavailable. The same single failure (1 EDG lost at time of RT) is assumed for SBLOCA cases where offsite power is not lost.</p>

Table 15.0-12—Radiological Consequences of U.S. EPR Design Basis Accidents (rem TEDE)

Design Basis Accident		Offsite Dose		Main Control Room Dose
		EAB (0.5 mile)	LPZ (1.5 miles)	
LOCA		12.2 (25) ¹	11.1 (25)	4.0 (5)
Small line break outside of Reactor Building		1.8 (2.5)	0.3 (2.5)	0.1 (5)
SGTR	Pre-incident spike	1.1 (25)	0.3 (25)	0.3 (5)
	Coincident spike	0.7 (2.5)	0.5 (2.5)	0.6 (5)
MSLB	Pre-incident spike	0.2 (25)	0.1 (25)	0.5 (5)
	Coincident spike	0.3 (2.5)	0.2 (2.5)	0.7 (5)
	Fuel rod cladding failure ²	5.3 (25)	2.6 (25)	4.5 (5)
	Fuel overheat ²	5.8 (25)	2.8 (25)	4.5 (5)
RCP locked rotor/broken shaft ²		2.3 (2.5)	0.9 (2.5)	1.3 (5)
Rod ejection ²		5.7 (6.3)	3.5 (6.3)	4.3 (5)
Fuel handling accident ³		5.6 (6.3)	1.0 (6.3)	0.5 (5)

Notes:

1. The values in parentheses represent the dose acceptance criteria.
2. Fuel failure in the MSLB, RCP locked rotor and REAs was maximized to produce approximately 90% of the acceptance criterion at the limiting receptor.
3. Post-shutdown decay for the fuel handling accident was minimized to yield approximately 90% of the acceptance criterion at the limiting receptor.

Table 15.0-13—Parameters Used to Calculate Design Basis Core Radionuclide Inventory

Parameter	Value
Total core thermal power (MW _t) for design-basis applications, including measurement uncertainty	4590 + 22 = 4612 MW _t
Number of fuel assemblies in core	241
Fuel enrichment U-235 wt %	2%–5%
Mass of UO ₂ in fuel assembly	607 kg
Maximum fuel assembly burnup	62 GWD/MTU

**Table 15.0-14—Design Basis Core Radionuclide Inventory
Sheet 1 of 2**

Radionuclide	Inventory (Ci)	Radionuclide	Inventory (Ci)	Radionuclide	Inventory (Ci)
Noble Gases		Tellurium Group		Cerium Group	
Kr-83m	1.96E+07	Sb-125	3.83E+06	Ce-141	2.24E+08
Kr-85m	4.50E+07	Sb-127	1.80E+07	Ce-143	2.28E+08
Kr-85	2.10E+06	Sb-129	4.85E+07	Ce-144	1.70E+08
Kr-87	9.02E+07	Te-127m	2.43E+06	Pu-238	1.46E+06
Kr-88	1.28E+08	Te-127	1.79E+07	Pu-239	6.14E+04
Kr-89	1.61E+08	Te-129m	7.08E+06	Pu-240	1.40E+05
Xe-131m	1.54E+06	Te-129	4.78E+07	Pu-241	2.53E+07
Xe-133m	8.92E+06	Te-131m	2.04E+07	Np-239	3.82E+09
Xe-133	2.89E+08	Te-131	1.24E+08		
Xe-135m	5.49E+07	Te-132	1.98E+08		
Xe-135	9.26E+07	Te-134	2.50E+08		
Xe-137	2.52E+08				
Xe-138	2.45E+08				
Halogens		Barium/Strontium Group		Noble Metals	
Br-83	1.96E+07	Sr-89	1.61E+08	Mo-99	2.59E+08
Br-84	3.62E+07	Sr-90	1.69E+07	Tc-99m	2.27E+08
Br-85	4.45E+07	Sr-91	2.07E+08	Ru-103	2.42E+08
I-129	8.33E+00	Sr-92	2.14E+08	Ru-105	1.96E+08
I-130	1.32E+07	Ba-137m	2.34E+07	Ru-106	1.43E+08
I-131	1.39E+08	Ba-139	2.62E+08	Rh-103m	2.18E+08
I-132	2.01E+08	Ba-140	2.52E+08	Rh-105	1.75E+08
I-133	2.90E+08			Rh-106	1.58E+08
I-134	3.18E+08				
I-135	2.69E+08				
Alkalis					
Rb-86m	5.53E+04	Rb-89	1.67E+08	Cs-137	2.47E+07
Rb-86	5.80E+05	Cs-134	6.48E+07	Cs-138	2.69E+08
Rb-88	1.29E+08	Cs-136	1.61E+07		

**Table 15.0-14—Design Basis Core Radionuclide Inventory
Sheet 2 of 2**

Radionuclide	Inventory (Ci)	Radionuclide	Inventory (Ci)	Radionuclide	Inventory (Ci)
Lanthanides					
Y-90	1.79E+07	Nb-95	2.29E+08	Pr-144	1.72E+08
Y-91m	1.20E+08	Ag-110m	2.42E+06	Nd-147	9.44E+07
Y-91	1.96E+08	Ag-110	7.15E+07	Am-241	2.88E+04
Y-92	2.14E+08	La-140	2.54E+08	Cm-242	1.31E+07
Y-93	2.34E+08	La-141	2.41E+08	Cm-244	6.94E+06
Zr-95	2.29E+08	La-142	2.35E+08		
Zr-97	2.43E+08	Pr-143	2.26E+08		

Table 15.0-15—U.S. EPR Primary Coolant Bounding Concentrations

Radio-nuclide	Concentration (μCi/gm)	Radio-nuclide	Concentration (μCi/gm)	Radio-nuclide	Concentration (μCi/gm)	Radio-nuclide	Concentration (μCi/gm)
Noble Gases		Tellurium Group		Cerium Group		Activation Products	
Kr-83m	1.28E-01	Sb-125	1.56E-06	Ce-141	9.12E-05	Na-24	3.7E-02
Kr-85m	5.71E-01	Sb-127	6.99E-06	Ce-143	7.96E-05	Cr-51	2.0E-03
Kr-85	5.31E+00	Sb-129	8.53E-06	Ce-144	6.93E-05	Mn-54	1.0E-03
Kr-87	3.26E-01	Te-127m	6.19E-04	Pu-238	5.97E-07	Fe-55	7.6E-04
Kr-88	1.03E+00	Te-127	3.05E-03	Pu-239	2.51E-08	Fe-59	1.9E-04
Kr-89	2.42E-02	Te-129m	1.79E-03	Pu-240	5.72E-08	Co-58	2.9E-03
Xe-131m	1.08E+00	Te-129	3.00E-03	Pu-241	1.03E-05	Co-60	3.4E-04
Xe-133m	1.35E+00	Te-131m	4.36E-03	Np-239	1.41E-03	Zn-65	3.2E-04
Xe-133	9.47E+01	Te-131	3.01E-03			W-187	1.8E-03
Xe-135m	1.95E-01	Te-132	4.70E-02				
Xe-135	3.40E+00	Te-134	6.80E-03				
Xe-137	4.57E-02						
Xe-138	1.64E-01						
Halogens		Ba/Sr Group		Noble Metals		Alkalis	
Br-83	3.16E-02	Sr-89	6.35E-04	Mo-99	1.21E-01	Rb-86m	5.32E-07
Br-84	1.67E-02	Sr-90	4.32E-05	Tc-99m	5.24E-02	Rb-86	3.66E-03
Br-85	2.01E-03	Sr-91	1.02E-03	Ru-103	1.00E-04	Rb-88	1.02E+00
I-129	4.59E-08	Sr-92	1.73E-04	Ru-105	1.47E-04	Rb-89	4.72E-02
I-130	4.97E-02	Ba-137m	1.50E-01	Ru-106	5.83E-05	Cs-134	4.18E-01
I-131	7.43E-01	Ba-139	2.30E-02	Rh-103m	8.85E-05	Cs-136	1.00E-01
I-132	3.71E-01	Ba-140	6.74E-04	Rh-105	6.62E-05	Cs-137	1.60E-01
I-133	1.25E+00	Tritium		Rh-106	5.84E-05	Cs-138	2.35E-01
I-134	2.40E-01	H-3	1.0E+00				
I-135	7.90E-01						
Lanthanides							
Y-90	1.03E-05	Zr-95	9.31E-05	La-140	1.76E-04	Nd-147	3.77E-05
Y-91m	5.23E-04	Zr-97	7.37E-05	La-141	5.77E-05	Am-241	1.18E-08
Y-91	8.10E-05	Nb-95	9.35E-05	La-142	3.38E-05	Cm-242	5.35E-06
Y-92	1.41E-04	Ag-110m	9.87E-07	Pr-143	9.20E-05	Cm-244	2.83E-06
Y-93	6.50E-05	Ag-110	4.72E-08	Pr-144	6.94E-05		

Table 15.0-16—U.S. EPR Secondary Coolant Bounding Concentrations

Radio-nuclide	Concentration (μCi/gm)	Radio-nuclide	Concentration (μCi/gm)	Radio-nuclide	Concentration (μCi/gm)	Radio-nuclide	Concentration (μCi/gm)
Noble Gases		Tellurium Group		Cerium Group		Activation Products	
Kr-83m	N/A	Sb-125	1.74E-09	Ce-141	1.01E-07	Na-24	3.53E-05
Kr-85m	N/A	Sb-127	7.60E-09	Ce-143	8.24E-08	Cr-51	2.22E-06
Kr-85	N/A	Sb-129	6.01E-09	Ce-144	7.72E-08	Mn-54	1.11E-06
Kr-87	N/A	Te-127m	6.89E-07	Pu-238	6.65E-10	Fe-55	8.47E-07
Kr-88	N/A	Te-127	2.82E-06	Pu-239	2.80E-11	Fe-59	2.11E-07
Kr-89	N/A	Te-129m	1.99E-06	Pu-240	6.37E-11	Co-58	3.23E-06
Xe-131m	N/A	Te-129	1.94E-06	Pu-241	1.15E-08	Co-60	3.79E-07
Xe-133m	N/A	Te-131m	4.48E-06	Np-239	1.50E-06	Zn-65	3.56E-07
Xe-133	N/A	Te-131	1.33E-06			W-187	1.81E-06
Xe-135m	N/A	Te-132	5.07E-05				
Xe-135	N/A	Te-134	1.64E-06				
Xe-137	N/A						
Xe-138	N/A						
Halogens		Ba/Sr Group		Noble Metals		Alkalis	
Br-83	1.61E-03	Sr-89	7.16E-07	Mo-99	1.30E-04	Rb-86m	3.99E-12
Br-84	3.05E-04	Sr-90	4.81E-08	Tc-99m	7.47E-05	Rb-86	7.27E-06
Br-85	3.93E-06	Sr-91	9.01E-07	Ru-103	1.11E-07	Rb-88	1.26E-04
I-129	4.81E-09	Sr-92	1.00E-07	Ru-105	1.09E-07	Rb-89	5.02E-06
I-130	4.33E-03	Ba-137m	3.01E-04	Ru-106	6.49E-08	Cs-134	8.38E-04
I-131	7.67E-02	Ba-139	1.03E-05	Rh-103m	9.97E-08	Cs-136	1.98E-04
I-132	2.27E-02	Ba-140	7.45E-07	Rh-105	7.58E-08	Cs-137	3.21E-04
I-133	1.17E-01	Tritium		Rh-106	6.49E-08	Cs-138	5.00E-05
I-134	6.68E-03	H-3	1.0E-03				
I-135	5.99E-02						
Lanthanides							
Y-90	1.29E-08	Zr-95	1.04E-07	La-140	2.28E-07	Nd-147	4.16E-08
Y-91m	5.38E-07	Zr-97	7.15E-08	La-141	4.06E-08	Am-241	1.32E-11
Y-91	9.17E-08	Nb-95	1.04E-07	La-142	1.51E-08	Cm-242	5.96E-09
Y-92	1.33E-07	Ag-110m	1.10E-09	Pr-143	1.02E-07	Cm-244	3.15E-09
Y-93	5.81E-08	Ag-110	1.47E-11	Pr-144	7.72E-08		

Table 15.0-17—Iodine Appearance Rates into RCS from Defective Fuel

Radionuclide	Appearance Rate	
	(Ci/hr)	(μ Ci/sec)
I-131	4.09E+01	1.14E+04
I-132	5.30E+01	1.47E+04
I-133	8.04E+01	2.23E+04
I-134	6.88E+01	1.91E+04
I-135	6.74E+01	1.87E+04

Table 15.0-18—Summary of MCR/TSC Characteristics

Description		Value	References and Remarks
Exposure interval		30 days	RG 1.183, Section 4.2.6
Outside air intakes		Worst-case MCR air intake on Safeguard Building Division 3 (for main MCR intake)	
		SAC HVAC air intake for Safeguard Building Division 3 (for unfiltered inleakage)	
Atmospheric dispersion factors (χ/Q)		Accident specific, as presented individually for each DBA	
Occupancy factor	0–24 hrs	100%	RG 1.183, Section 4.2.6
	24–96 hrs	60%	
	96–720 hrs	40%	
Breathing rate		3.5E-04 m ³ /sec	RG 1.183, Section 4.2.6
Free air volume of MCR envelope		200,000 ft ³	Total volume consists of 133,000 ft ³ for MCR proper on elevation 53 feet, plus 67,000 ft ³ HVAC room on elevation 69 feet)
Charcoal filtration system actuation time (delay time for system re-alignment)		1 min	Automatic actuation based on either a containment isolation signal or high radiation level at the intake duct radiation monitor
Filtration efficiency (halogens and particulates), intake, and recirculation-flow filters		99%	4-inch charcoal beds
Number of charcoal filtration systems in service		1 train	
Pre-isolation unfiltered intake flow		750 cfm/train 1500 cfm total	Two trains assumed to be operating before the DBA
Post-isolation filtered intake flow		1000 cfm (single train)	
Pre- and post-isolation unfiltered inleakage from areas surrounding the MCR pressure envelope, including ingress and egress		50 cfm total	Includes 10 cfm for egress and ingress
Post isolation filtered recirculation flow		3000 cfm/train	
Floor thickness concrete shielding MCR proper from filters		50 cm	
Air intake duct radiation monitor range		1.0E-05–10 rad/hr	Nominal set point at 3× background

Table 15.0-19—Offsite Receptor Variables

Description		Value	References and Remarks	
Atmospheric dispersion (ground-level release)		See Table 2.1-1		
Distance	EAB	0.5 mile	Assumed value	
	LPZ	1.5 miles	Assumed value	
Exposure interval	EAB	2 hrs	RG 1.183, Section 4.1.5	
	LPZ	30 days	RG 1.183, Section 4.1.6	
Breathing rate	EAB	0–2 hrs	3.5E-04 m ³ /s	
	LPZ	0–8 hrs		3.5E-04 m ³ /s
		8–24 hrs		1.8E-04 m ³ /s
		1–30 days		2.3E-04 m ³ /s

Table 15.0-20—Design Input for Failure of Small Lines Carrying Primary Coolant Outside Containment

Description		Value	References and Remarks
Source Term			
RCS radionuclide concentrations		See Table 15.0-15 and Table 15.0-16	
Reactor Coolant System Variables			
Coolant volume in RCS and pressurizer		15,009 ft ³	
Coolant mass in RCS and pressurizer		6.47E+05 lb _m	
Reactor coolant letdown flow rate for purification	Nominal flow	79,366 lb _m /hr	
	Conservative value for iodine spiking calculation	120,000 lb _m /hr	
Primary to secondary leak rate		600 gallons/day (209 lb _m /hr)	TS limit
Fraction of RCS activity removed in passing through the purification mixed-bed demineralizers		Iodines: 0.99 Alkali metals: 0.5 Particulates: 0.98	
Increase in the equilibrium iodine activity release rate from the fuel (accident induced concurrent iodine spike)		Factor of 500	Reference 1
U.S. EPR proposed TS limits for the RCS radionuclide concentrations	Iodines	1 μCi/gm DE I-131	Proposed TS limits
	Noble gases	210 μCi/gm DE Xe-133	
Break locations and flows		See Table 15.0-21	
Iodine appearance rates		See Table 15.0-17	
Offsite receptor variables		See Table 15.0-19	
MCR variables		See Table 15.0-18	
MCR composite (χ/Q)s and intake filter bypass fractions		See Table 15.0-22	

Table 15.0-21—Design Input for NSS and CVCS Break Locations and Flows

Break Description	Parameter		Analytical Value	Remarks
SLB 1-Break in Nuclear Sampling System (NSS)				
Double-ended guillotine rupture of the 1/4 inch liquid phase sampling line leading to the pressurizer, hot leg 1 or crossover leg 3. In each case, the break location is between the containment penetration and the sampling-line heat exchanger in the Fuel Building.	Line size and Schedule		1/4 inch Sch. 40ST	
	Line transverse (flow) area		0.000723 ft ²	
	Pressurizer	Critical mass flux	11,034 lb _m /ft ² -sec	Henry-Fauske model
	Hot leg 1	Critical mass flux	15,998 lb _m /ft ² -sec	
	Crossover leg 3 (bounding)	Critical mass flux	22,243 lb _m /ft ² -sec	
		Flow rate	5.80E+04 lb _m /hr	
		Flashing fraction	40%	
Break isolation time		30 min	Operator manual action from MCR	
SLB 2-Break in CVCS Connecting Line				
Double-ended guillotine rupture of 6-inch line between the VCT and the VCT suction valves	VCT volume		671 ft ³	
	Break Flow		176,200 lb _m /hr	
	Coolant Temperature		122°F	
	Coolant density		61.7 lb _m /ft ³	
	Break isolation time		30 min	Operator manual action from MCR

Table 15.0-22—MCR Composite χ/Q and Filter-Bypass Fractions for Small-Line Break Releases at the Vent Stack Base

Time Interval (hrs)		SAB Division 3 Intake (Main Flow)		SAC Division 3 Intake (Unfiltered Inleakage)		Composite χ/Q (s/m ³)	Filter Bypass Fraction
Start	End	χ/Q (s/m ³)	Flow (cfm)	χ/Q (s/m ³)	Flow (cfm)		
0	0.0167 (1 min)	1.93E-03	1500	4.30E-03	50	2.01E-03	1.00E+00
0.0167	2	1.93E-03	1000	4.30E-03	50	2.04E-03	1.00E-01

Table 15.0-23—Small Line Break - Dose Results

Line Break	TEDE Dose (rem)	
	NSS 1/4 inch Line Break	CVCS 6 inch Line Break
EAB (0.5 mile)	1.80	7.15E-02
LPZ (1.5 mile)	0.316	1.25E-02
MCR with automatic isolation in 1 minute	6.48E-02 ¹	1.37E-02

Note:

1. Includes 4.75 mrem for filter shine from the iodine absorption in the filter.

Table 15.0-24—SGTR Accident Time Line

Event	Time
DEG rupture of a single U-tube on the hot side of the tubesheet	0.0
CVCS charging pumps start	2.6 min
Manual RT with LOOP	30.0 min
MFW pumps and RCPs lose power	30.0 min
Manual SI start	39.9 min
SI Start of Partial Cooldown	39.9 min
Initiation of EFW (SI + LOOP), EFW pump of an unaffected SG on Pr. Maintenance SG blowdown isolates, affected SG EFW CV fails fully open	39.9 min
Initiate closure of affected SG MSIV Reset affected SG MSRT setpoint to 1405.5 psia, affected MSRT closes	40.0 min
Affected SG MSRIV low steam pressure isolation setpoint reached, MSRIV closure initiated (excludes 1 min delay for valve closure)	40.9 min
End of Partial Cooldown, Initiate 90°F/hr SG cooldown in 3 intact SGs using MSRTs	59.9 min
Manual Initiation of EBS pumps to add concentrated boron and provide RCS makeup	59.9 min
Terminate MHSI flow, subcooling > 50°F	1.4 hr
EBS tanks empty, EBS pumps stop	3.9 hr
Operator cycles PSRV to maintain RCS pressure approximately equal to affected SG pressure	1- 8 hr

Table 15.0-25—SGTR Design Input
Sheet 1 of 2

Description		Value	References and Remarks
Source Term			
RCS radionuclide concentrations	Iodines	1 $\mu\text{Ci/gm}$ DE I-131	The halogens and noble gases are at the proposed TS limits for DE I-131 and DE Xe-133. See Table 15.0-15.
	Noble gases	210 $\mu\text{Ci/gm}$ DE Xe-133	
	Others	Design basis, at 0.25% failed fuel fraction	
Proposed TS limits for SG secondary-side concentration	Halogens	0.1 $\mu\text{Ci/gm}$ DE I-131	
	Others	Not controlled	
Secondary side radionuclide concentrations		See Table 15.0-16	
Iodine appearance rate		See Table 15.0-17	
Alternative iodine spike scenarios (independently analyzed)	Pre-accident spike due to transient	60 $\mu\text{Ci/gm}$ DE I-131	RG 1.183, Appendix F
	Concurrent spike	335-fold increase in iodine appear. rate	RG 1.183, Appendix F
S-RELAP5 Thermal Hydraulic Response			
Thermal hydraulic data (with condensed time steps)		See Table 15.0-26 and 15.0-27	Arrays with an extended list of time steps are used in the analyses.
Atmospheric Release Pathway			
Primary to secondary leakage rate (conservatively assumed to last for 30 days)	Any one SG	0.125 gpm/SG	Assumed to be at cold conditions
	3 intact SGs	187.8 lb _m /hr	Calculated value
SG total secondary volume (water + steam)		8393.6 ft ³ /SG	
Partition coefficient for halogens in SG water		100	
Steam carryover of alkalis		1%	
Halogen and alkali depletion due to scrubbing, and due to plateout on internal surfaces and steam lines		0	None credited (conservative)
Halogen and alkali DF due to deposition within the condenser system		100	Based on References 14 and 15 (see description in 15.0.3.6.3)

**Table 15.0-25—SGTR Design Input
Sheet 2 of 2**

Description		Value	References and Remarks
Chemical composition of halogens released to atmosphere	Elemental	97%	RG 1.183, Appendix F, Section 4
	Organic	3%	
Atmospheric release pathway and duration	Via condenser, while at full power	0–30 min	For the MCR doses, all atmospheric releases were conservatively assumed to be via the MSRT, which is closest to the MCR intake.
	Via MSRTs/silencers	After 30 min	
Other Variables			
Iodine appearance rates		See Table 15.0-17	
Offsite receptor variables		See Table 15.0-19	
MCR variables		See Table 15.0-18	MCR isolation actuated by high radiation signal in intake duct set at a nominal 3 × background
MCR composite χ/Q and intake filter bypass fractions		See Table 15.0-28	

Table 15.0-26—SGTR Thermal-Hydraulic Variable Definitions

Thermal-Hydraulic Variable Name and Units	Variable Description
PCMAS (lb _m)	RCS mass
LDNI (lb _m /hr)	Letdown flow, intact SGs
LDNR (lb _m /hr)	Letdown flow, ruptured SG
STMRI (lb _m /hr)	Steaming rate, intact SGs
STMRR (lb _m /hr)	Steaming rate, ruptured SG
WTRI (lb _m)	Water mass, intact SGs
WTRR (lb _m)	Water mass, ruptured SG
LEAKR (lb _m /hr)	Leak rate, ruptured SG
FLSHR (fraction)	Flashing fraction, ruptured SG
WDENI (lb _m /ft ³)	Water density, intact SGs
WDENR (lb _m /ft ³)	Water density, ruptured SG
SDENI (lb _m /ft ³)	Steam density, intact SGs
SDENR (lb _m /ft ³)	Steam density, ruptured SG

Table 15.0-27—Condensed Thermal-Hydraulic Data Arrays
Sheet 1 of 2

Post-SGTR Time (hr)	Thermal-Hydraulic Variables						
	PCMASS (lb _m)	LEAKR (lb _m /hr)	LDNI (lb _m /hr)	LDNR (lb _m /hr)	STMRI (lb _m /hr)	STMRR (lb _m /hr)	WTRI (lb _m)
0.000	6.595E+05	1.512E+05	1.558E+05	5.195E+04	1.552E+07	5.188E+06	4.730E+05
0.228	6.573E+05	1.668E+05	1.558E+05	5.195E+04	1.533E+07	5.132E+06	4.727E+05
0.489	6.590E+05	1.712E+05	1.558E+05	5.195E+04	1.074E+07	3.597E+06	4.692E+05
0.550	6.508E+05	1.708E+05	1.558E+05	5.195E+04	1.585E+04	2.931E+04	4.512E+05
0.690	6.302E+05	1.476E+05	6.919E+04	1.583E+04	4.190E+05	5.963E+05	3.024E+05
0.800	6.159E+05	0.000E+00	0.000E+00	0.000E+00	1.217E+03	0.000E+00	3.579E+05
0.922	6.024E+05	0.000E+00	0.000E+00	0.000E+00	4.622E+04	0.000E+00	4.319E+05
1.044	5.967E+05	0.000E+00	0.000E+00	0.000E+00	2.167E+05	0.000E+00	4.895E+05
1.167	6.363E+05	0.000E+00	0.000E+00	0.000E+00	6.821E+04	0.000E+00	5.462E+05
1.411	7.094E+05	0.000E+00	0.000E+00	0.000E+00	1.700E+05	0.000E+00	6.691E+05
1.533	7.105E+05	0.000E+00	0.000E+00	0.000E+00	2.969E+05	0.000E+00	6.903E+05
2.022	7.316E+05	0.000E+00	0.000E+00	0.000E+00	3.063E+05	0.000E+00	6.764E+05
3.856	8.224E+05	0.000E+00	0.000E+00	0.000E+00	2.627E+05	0.000E+00	7.280E+05
5.567	8.364E+05	0.000E+00	0.000E+00	0.000E+00	1.425E+05	0.000E+00	9.423E+05
8.000	8.365E+05	0.000E+00	0.000E+00	0.000E+00	1.327E+05	0.000E+00	9.452E+05
Post-SGTR Time (hr)	Thermal-Hydraulic Variables						
	WTRR (lb _m)	FLSHR (fraction)	WDENI (lb _m /ft ³)	WDENR (lb _m /ft ³)	SDENI (lb _m /ft ³)	SDENR (lb _m /ft ³)	
0.000	1.688E+05	9.482E-02	4.630E+01	4.630E+01	2.249E+00	2.250E+00	
0.228	1.699E+05	9.621E-02	4.629E+01	4.628E+01	2.253E+00	2.253E+00	
0.489	1.676E+05	6.983E-02	4.579E+01	4.579E+01	2.385E+00	2.388E+00	
0.550	1.694E+05	3.869E-02	4.401E+01	4.401E+01	2.885E+00	2.937E+00	
0.690	1.222E+05	7.272E-02	4.716E+01	4.822E+01	1.933E+00	1.607E+00	
0.800	1.240E+05	0.000E+00	4.719E+01	4.617E+01	1.896E+00	1.998E+00	
0.922	1.363E+05	0.000E+00	4.697E+01	4.516E+01	1.946E+00	2.348E+00	
1.044	1.466E+05	0.000E+00	4.734E+01	4.478E+01	1.910E+00	2.555E+00	
1.167	1.517E+05	0.000E+00	4.797E+01	4.481E+01	1.725E+00	2.637E+00	
1.411	1.597E+05	0.000E+00	4.914E+01	4.473E+01	1.417E+00	2.727E+00	
1.533	1.651E+05	0.000E+00	4.969E+01	4.464E+01	1.277E+00	2.782E+00	
2.022	1.655E+05	0.000E+00	5.176E+01	4.484E+01	8.443E-01	2.728E+00	
3.865	1.552E+05	0.000E+00	5.707E+01	4.527E+01	1.689E-01	2.558E+00	

**Table 15.0-27—Condensed Thermal-Hydraulic Data Arrays
Sheet 2 of 2**

Post-SGTR Time (hr)	Thermal-Hydraulic Variables					
	WTRR (lb _m)	FLSHR (fraction)	WDENI (lb _m /ft ³)	WDENR (lb _m /ft ³)	SDENI (lb _m /ft ³)	SDENR (lb _m /ft ³)
5.567	1.436E+05	0.000E+00	5.809E+01	4.555E+01	1.033E-01	2.420E+00
8.000	1.434E+05	0.000E+00	5.809E+01	4.567E+01	1.054E-01	2.368E+00

Note:

1. LEAKR, STMRR and FLSHR are equal to 0 at 0.698 hrs.

Table 15.0-28—MCR Composite χ/Q and Filter-Bypass Fractions Post-SGTR Releases via the SG 3 Silencer

Time Interval (hrs)		SAB Division 3 Intake (Main Flow)		SAC Division 3 Intake (Unfiltered Inleakage)		Composite χ/Q (sec/m ³)	Filter Bypass Fraction
Start	End	χ/Q (sec/m ³)	Flow (cfm)	χ/Q (sec/m ³)	Flow (cfm)		
0	0.0167 (1 min)	4.30E-03	1500	1.76E-02	50	4.73E-03	1.000E+00
0.0167	2	4.30E-03	1000	1.76E-02	50	4.93E-03	1.699E-01
2	8	3.71E-03	1000	1.48E-02	50	4.24E-03	1.663E-01
8	24	1.46E-03	1000	5.88E-03	50	1.67E-03	1.676E-01
24	96	1.12E-03	1000	4.55E-03	50	1.28E-03	1.688E-01
96	720	1.03E-03	1000	4.16E-03	50	1.18E-03	1.680E-01

Table 15.0-29—SGTR Dose Summary

SGTR Iodine Spike Scenario	TEDE Dose (rem)		
	EAB	LPZ	MCR
Pre-accident iodine spike	1.10 (25) ¹	0.29 (25)	0.29 (5)
Concurrent iodine spike	0.69 (2.5)	0.46 (2.5)	0.55 (5)

Note:

1. The values in parentheses represent the dose acceptance criteria.

Table 15.0-30—MSLB Time Line

Event	Time
Time of MSLB, and actuation of RT, TT and MSL isolation (triggered by low pressure in the affected MSL), and initiation of plant cooldown via steaming. No LOOP was assumed since it leads to less restrictive consequences.	0 s
SG 3 resubmergence of tube uncover, resulting from stuck-open MSRCV	30 min
Releases via the unaffected SGs terminate (RHR cooldown cut-in)	8 hrs
Release via affected SG terminates (RCS temperature reaches 212°F)	9 hrs

Table 15.0-31—MSLB Design Input
Sheet 1 of 2

Description		Value	References and Remarks
Source Term			
Core inventory		See Table 15.0-14	
Radial peaking factor		1.7	
Fuel rod activity gap fractions	I-131	8%	RG 1.183, Table 3
	Other halogens	5%	
	Kr-85	10%	
	Other noble gases	5%	
	Alkalis (Cs, Rb)	12%	
DNB-induced clad failure		3.3%	Determined to independently yield approximately 90% of dose acceptance criterion at the worst-case receptor
FCM-induced full-rod fuel melt		0.58%	
Primary and secondary side coolant radionuclide concentrations		See Tables 15.0-15 and 15.0-16	
Iodine appearance rates from defective fuel		See Table 15.0-17	
Iodine spiking alternatives analyzed	Pre-accident spike	60 μ Ci/gm DE-I131	RG 1.183, Appendix E, Sections 2.1 and 2.2
	Concurrent spike	500-fold increase in appearance rate, for 8 hrs	
Fraction of gap activity released to RCS (instantaneous release, uniform mixing)		100%	RG 1.183, Appendix E, Section 3
Fraction of melted-fuel inventory released to RCS	Halogens	50%	RG 1.183, Appendix H, Section 1 (for the REA, assumed to also apply for the MSLB)
	Noble gases	100%	
Reactor Coolant System Variables			
Coolant volume in RCS and pressurizer		15,009 ft ³	
Coolant mass in RCS and pressurizer		6.47E+05 lb _m	
Primary to secondary leak rate used in analysis		0.125 gpm/SG	
Secondary Side Coolant Variables			
SG water inventory	100% power	1.698E+05 lb _m /SG	
	Hot shutdown	2.311E+05 lb _m /SG	
	Average	2.005E+05 lb _m /SG	For fractional steaming rate
Iodine partition coefficient in secondary-side water		100	RG 1.183, Appendix E, Section 5.5.4
Alkali steam carry over fraction		1%	

**Table 15.0-31—MSLB Design Input
Sheet 2 of 2**

Description	Value	References and Remarks
Other Variables		
Duration of tube uncovered for SG connected to MSL with stuck open MSRCV (SG 3)	30 min	
Overall steaming rate for plant cooldown	113 lb _m /sec	Includes analytical margin of 1.2
Time at which plant cooldown is switched from SG steaming to the RHR	8 hrs	
Time for RCS coolant temperature to reach 212°F	9 hours from t=0	
Offsite receptor variables	See Table 15.0-19	
MCR variables	See Table 15.0-18	MCR isolation actuated by PCIS
MCR composite (χ/Q)s and intake filter bypass fractions for releases via MSRTs and silencers	See Table 15.0-32	
MCR composite (χ/Q)s and intake filter bypass fractions for releases via Canopy Pt. 1	See Table 15.0-33	

Table 15.0-32—MCR Composite (χ/Q)s and Filter-Bypass Fractions for Post-MSLB Releases via the SG 1, SG 2, and SG 3 Silencers

Time Interval (hrs)		SAB Division 3 Intake (Main Flow)		SAC Division 3 Intake (Unfiltered Inleakage)		Composite χ/Q (sec/m ³)	Filter Bypass Fraction
Start	End	χ/Q (sec/m ³)	Flow (cfm)	χ/Q (sec/m ³)	Flow (cfm)		
0	0.0167 (1 min)	4.30E-03	1500	1.76E-02	50	4.73E-03	1.000E+00
0.0167	2	4.30E-03	1000	1.76E-02	50	4.93E-03	1.699E-01
2	8	3.71E-03	1000	1.48E-02	50	4.24E-03	1.663E-01
8	24	1.46E-03	1000	5.88E-03	50	1.67E-03	1.676E-01
24	96	1.12E-03	1000	4.55E-03	50	1.28E-03	1.688E-01
96	720	1.03E-03	1000	4.16E-03	50	1.18E-03	1.680E-01

Table 15.0-33—MCR Composite χ/Q and Filter-Bypass Fractions (MSLB Releases via the MSL Break and Canopy Pt. 1)

Time Interval (hrs)		SAB Division 3 Intake (Main Flow)		SAC Division 3 Intake (Unfiltered Inleakage)		Composite χ/Q (sec/m ³)	Filter Bypass Fraction
Start	End	χ/Q (sec/m ³)	Flow (cfm)	χ/Q (s/m ³)	Flow (cfm)		
0	0.0167 (1 min)	6.52E-03	1500	1.67E-02	50	6.85E-03	1.000E+00
0.0167	2	6.52E-03	1000	1.67E-02	50	7.00E-03	1.135E-01
2	8	5.68E-03	1000	1.47E-02	50	6.11E-03	1.146E-01
8	24	2.34E-03	1000	5.96E-03	50	2.51E-03	1.130E-01
24	96	1.63E-03	1000	4.28E-03	50	1.76E-03	1.161E-01
96	720	1.50E-03	1000	3.89E-03	50	1.61E-03	1.148E-01

Table 15.0-34—MLSB Dose Summary

Receptor	TEDE Doses (rem) and Acceptance Criteria			
	Pre-Accident Iodine Spike	Concurrent Iodine Spike	3.3% Fuel-Rod Clad Failure	0.58% Full-Rod Fuel Melt
EAB	0.24 (25) ¹	0.27 (2.5)	5.3 (25)	5.8 (25)
LPZ	0.06 (25)	0.20 (2.5)	2.6 (25)	2.8 (25)
MCR	0.52 (5)	0.72 (5)	4.5 (5)	4.5 (5)

Note:

1. The values in parentheses represent the dose acceptance criteria.

Table 15.0-35—LRA Time Line

Event	Time
Instantaneous seizure of RCS pump rotor in Loop 3, coincident with LOOP, RT, MSIV closures, and initiation of plant cooldown via steaming.	0 s
SG 3 tube resubmergence following uncovered period resulting from stuck-open MSRCV, and closure of associated MSRIV, terminating releases from SG 3.	15 min
Releases via the unaffected SGs terminate (RHR cooldown cut-in).	8 hrs

**Table 15.0-36—Design Input for Locked Rotor Accident
Sheet 1 of 2**

Description		Value	References and Remarks
Source Term			
Core inventory		See Table 15.0-14	
Radial peaking factor		1.7	
Fuel rod activity gap fractions	I-131	8%	RG 1.183, Table 3
	Other halogens	5%	
	Kr-85	10%	
	Other noble gases	5%	
	Alkalis (Cs, Rb)	12%	
DNB-induced clad failure		9.5%	Determined to yield approximately 90% of dose acceptance criterion at worst-case receptor
Primary and secondary side coolant radionuclide concentrations		See Tables 15.0-15 and 15.0-16	
Pre-accident halogen spike (assumed to be the same as for the MSLB)		60 μ Ci/gm DE-I131	RG 1.183, Appendix E, Secs. 2.1 and 2.2
Fraction of gap activity released to RCS (instantaneous release, uniform mixing)		100%	RG 1.183, Appendix E, Section 3
Reactor Coolant System Variables			
Coolant volume in RCS and pressurizer		15,009 ft ³	
Coolant mass in RCS and pressurizer		6.47E+05 lb _m	
Primary to secondary leak rate used in analysis		0.125 gpm/SG	
Secondary Side Coolant Variables			
SG water inventory	100% power	1.698E+05 lb _m /SG	For fractional steaming rate value
	Hot shutdown	2.311E+05 lb _m /SG	
	Average	2.005E+05 lb _m /SG	
Iodine partition coefficient in secondary-side water		100	RG 1.183, Appendix E, Section 5.5.4
Alkali steam carry over fraction		1%	
Other Variables			
Duration of tube uncovered period for SG connected to MSL with stuck open MSRCV (SG 3)		15 min	
Overall steaming rate for plant cooldown		113 lb _m /s	Includes analytical margin of 1.2

**Table 15.0-36—Design Input for Locked Rotor Accident
Sheet 2 of 2**

Description	Value	References and Remarks
Time at which plant cooldown is switched from SG steaming to the RHR	8 hrs	
Offsite receptor variables	See Table 15.0-19	
MCR variables	See Table 15.0-18	MCR isolation actuated by PCIS
MCR composite (χ/Q) and intake filter bypass fractions for releases via MSRTs and silencers	See Table 15.0-37	

Table 15.0-37—MCR Composite χ/Q and Filter-Bypass Fractions RCP Locked Rotor Accident Releases via the SG 3 Silencer

Time Interval (hrs)		SAB Division 3 Intake (Main Flow)		SAC Division 3 Intake (Unfiltered Inleakage)		Composite χ/Q (s/m ³)	Filter Bypass Fraction
Start	End	χ/Q (s/m ³)	Flow (cfm)	χ/Q (s/m ³)	Flow (cfm)		
0	0.0167 (1 min)	4.30E-03	1500	1.76E-02	50	4.73E-03	1.000E+00
0.0167	2	4.30E-03	1000	1.76E-02	50	4.93E-03	1.699E-01
2	8	3.71E-03	1000	1.48E-02	50	4.24E-03	1.663E-01
8	24	1.46E-03	1000	5.88E-03	50	1.67E-03	1.676E-01
24	96	1.12E-03	1000	4.55E-03	50	1.28E-03	1.688E-01
96	720	1.03E-03	1000	4.16E-03	50	1.18E-03	1.680E-01

Table 15.0-38—RCP LRA Dose Summary

TEDE Doses with 9.5% Clad Failure and Regulatory Limits		
EAB	LPZ	MCR/TSC
2.25 (2.5) ¹ rem	0.87 (2.5) rem	1.31 (5) rem

Note:

1. The values in parentheses represent the dose acceptance criteria.

Table 15.0-39—Rod Ejection Accident Timeline

Action	Time
REA takes place coincident with LOOP, RT and MSIV closures, leading to the instantaneous release of activity to the RCS from clad failure and fuel overheat/melt; plant cooldown initiated via steaming, for the secondary-side leakage pathway.	0 s
Termination of primary containment purge flow, for the primary containment leakage pathway, actuated by the PCIS.	10 s
End of annulus (secondary containment) drawdown time.	305 s
Releases via an SG steaming terminate for the secondary-side leakage pathway (RHR cooldown cut-in).	8 hrs
Analysis terminated for the primary containment leakage pathway.	30 days

Table 15.0-40—Design Input for Rod Ejection Accident
Sheet 1 of 3

Description		Value	References and Remarks
Source Term			
Core inventory		See Table 15.0-14	
Radial peaking factor		1.7	
Fuel rod activity gap fractions	Halogens	10%	RG 1.183, Table 3
	Noble gases	10%	
	Alkalis	12%	
Primary and secondary side coolant radionuclide concentrations		See Tables 15.0-15 & 15.0-16	
Pre-accident halogen spike (assumed to be the same as for the MSLB)		60 μ Ci/gm DE-1131	RG 1.183, Appendix E, Section 2.1
Reactor Coolant System Variables			
Coolant volume in RCS and pressurizer		15,009 ft ³	
Coolant mass in RCS and pressurizer		6.47E+05 lb _m	
Primary to secondary leak rate used in analysis		0.125 gpm/SG	
Secondary Side Coolant Variables			
SG water inventory	100% power	1.698E+05 lb _m /SG	For fractional steaming rate value
	Hot shutdown	2.311E+05 lb _m /SG	
	Average	2.005E+05 lb _m /SG	
Iodine partition coefficient in secondary-side water		100	RG 1.183, Appendix E, Section 5.5.4
Alkali steam carry over fraction		1%	
Primary Containment Leakage Pathway			
Fuel damage (produces approximately 90% of criterion at worst-case receptor)	Cladding failure	Table 15.0-44	Includes rods that overheat/melt
	Full-rod fuel overheat/melt	Table 15.0-44	Set equal to 4% of cladding failure (Source term excludes gap activity)
Fraction of gap activity released to containment (instantaneous release, uniform mixing)		100%	RG 1.183, Appendix H, Section 1. The release from overheated fuel is conservatively assumed to be same as that from melted fuel.
Fraction of overheated fuel inventory released to containment	Halogens	25%	
	Noble gases	100%	

**Table 15.0-40—Design Input for Rod Ejection Accident
Sheet 2 of 3**

Description		Value	References and Remarks
Chemical composition of core-inventory halogens	Elemental	4.85%	RG 1.183, Appendix H, Section 4
	Organic	0.15%	
	Particulate (CsI)	95%	
Primary containment (PC) free air volume		2.8E+06 ft ³	
Pre-REA PC filtered purge	Flow	3210 cfm	Terminated by PCIS signal
	Duration	10 s	
Post-REA annulus drawdown time		305 s	
Post-REA iodine and aerosol removal by sprays		Not credited	
Containment leakage rate (L_a)	0–24 hrs	0.25 % per day	Reduction by 50%, per RG 1.183, Appendix H, Section 6.2
	> 24 hrs	0.125 % per day	
Natural deposition decontamination coefficients for aerosols		See Table 15.0-41	
Natural deposition decontamination coefficients for elemental iodines		Same as for the aerosols, except limited to a DF of 100	Conservative assumption
Primary containment leakage to Safeguard Building (bypassing annulus)		0	Conservative assumption
Mixing and holdup within annulus		Not credited	Design does not conform with the mixing requirements specified in RG 1.183, App. A, Section 4.3.
Release point to atmosphere	During annulus drawdown time	Adjacent to SG 3 silencer	
	During purge and after annulus drawdown	Base of vent stack	
Exhaust filtration efficiency under accident conditions (PCIS-actuated annulus KLB system)		99%	For 4-inch activated carbon bed and 70% relative humidity

**Table 15.0-40—Design Input for Rod Ejection Accident
Sheet 3 of 3**

Description		Value	References and Remarks
Secondary-Side Leakage Pathway			
Fuel damage (determined to yield approximately 90% of dose acceptance criterion at worst-case receptor)	Clad failure	See Table 15.0-44	Includes rods that overheat
	Full-rod fuel overheat	See Table 15.0-44	Set equal to 4% of clad failure (Source term excludes gap activity)
Fraction of gap activity released to RCS (instantaneous release, uniform mixing)		100%	RG 1.183, Appendix H, Section 1. (The release from overheated fuel is conservatively assumed to be same as that from melted fuel.)
Fraction of overheated fuel inventory released to RCS	Halogens	50%	
	Noble gases	100%	
Plant cooldown average steaming rate via all four MSRTs to RHR cut-in at 250°F RCS temperature)		113 lb _m /s	
Partition coefficient for halogens in SG water		100	RG 1.183, Appendix E, Section 5.5.4
Steam carryover of alkalis		1%	
Chemical composition of halogens released to atmosphere	Elemental	97%	RG 1.183, Appendix H, Section 5
	Organic	3%	
Other Variables			
Time at which plant cooldown is switched from SG steaming to the RHR		8 hrs	
Offsite receptor variables		See Table 15.0-19	
MCR variables		See Table 15.0-18	MCR isolation actuated by PCIS
MCR composite χ/Q_s and intake filter bypass fractions for Primary Containment Leakage pathway		See Table 15.0-42	Releases at base of vent stack
MCR composite χ/Q_s and intake filter bypass fractions for the secondary-side leakage pathway		See Table 15.0-43	Releases via MSRTs/silencers

**Table 15.0-41—Correlations of PWR Effective Natural Deposition
Decontamination Coefficients for Aerosols (NUREG/CR-6604, Reference 16,
Section 2.2.2.1, Combined Powers and Henry models)**

Time Interval (hr)		Deposition Factor for Elemental Iodines and other Particulates (hr ⁻¹)
Start	End	
0	0.00833 (30 s)	0.0
0.00833	1.8	0.032
1.8	3.8	0.092
3.8	13.8	0.128
13.8	22.2	0.086
22.2	37.5	0.0529
37.5	56.9	0.0407
56.9	82	0.0314
82	109.7	0.025
109.7	239.2	0.0138
239.2	720	0.00565

**Table 15.0-42—MCR Composite χ/Q and Filter-Bypass Fractions, Post-REA
Primary Containment Leakage Pathway**

Time Interval		Release Pathway	SAB Division 3 Intake (Main Flow)		SAC Division 3 Intake (Unfiltered Inleakage)		Composite χ/Q (sec/m ³)	MCR Filter Bypass Fraction
Start	End		χ/Q (s/m ³)	Flow (cfm)	χ/Q (s/m ³)	Flow (cfm)		
0	10 s	Filtered purge flow via vent stack	1.93E-03	1.50E+03	4.30E-03	5.00E+01	2.01E-03	1.00E+00
10 s	60 s	Unfiltered leakage during drawdown, near SG 3 silencer	4.30E-03	1.50E+03	1.76E-02	5.00E+01	4.73E-03	1.00E+00
60 s	305 s		4.30E-03	1.00E+03	1.76E-02	5.00E+01	4.93E-03	1.70E-01
305 s	2 hrs	Post drawdown primary containment filtered leakage via vent stack	1.93E-03	1.00E+03	4.30E-03	5.00E+01	2.04E-03	1.00E-01
2 hr	8 hrs		1.73E-03	1.00E+03	3.71E-03	5.00E+01	1.82E-03	9.68E-02
8 hrs	24 hrs		6.74E-04	1.00E+03	1.46E-03	5.00E+01	7.11E-04	9.77E-02
24 hrs	96 hrs		5.12E-04	1.00E+03	1.12E-03	5.00E+01	5.41E-04	9.86E-02
96 hrs	720 hrs		4.72E-04	1.00E+03	1.03E-03	5.00E+01	4.99E-04	9.84E-02

Table 15.0-43—MCR Composite (χ/Q)s and Filter-Bypass Fractions, Post-REA Secondary-Side Leakage Pathway

Time Interval (hrs)		SAB Div. 3 Intake (Main Flow)		SAC Div. 3 Intake (Unfiltered Inleakage)		Composite χ/Q (s/m ³)	Filter Bypass Fraction
Start	End	χ/Q (s/m ³)	Flow (cfm)	χ/Q (s/m ³)	Flow (cfm)		
0	0.0167 (1 min)	4.30E-03	1500	1.76E-02	50	4.73E-03	1.000E+00
0.0167	2	4.30E-03	1000	1.76E-02	50	4.93E-03	1.699E-01
2	8	3.71E-03	1000	1.48E-02	50	4.24E-03	1.663E-01
8	24	1.46E-03	1000	5.88E-03	50	1.67E-03	1.676E-01
24	96	1.12E-03	1000	4.55E-03	50	1.28E-03	1.688E-01
96	720	1.03E-03	1000	4.16E-03	50	1.18E-03	1.680E-01

Note:

1. The effective χ/Q_s in this table for the SAB intake are the averages releases via all four silencers, and those for the SAC intake are the averages for SG 1 and SG 2, or SG 3 and SG 4.

Table 15.0-44—REA Dose Summary

Release Pathway	TEDE Dose (rem)			Percent of Total Core	
	EAB	LPZ	MCR	Cladding Failure	Overheat
Containment leakage, with filtered purge for 10 s.	5.66 (6.3) ¹	1.77(6.3)	1.83 (5)	33.4%	0.0%
	5.66 (6.3)	1.74 (6.3)	1.73 (5)	28.6%	1.14%
Secondary-Side Leakage.	5.65 (6.3)	3.49 (6.3)	4.33 (5)	36.7%	0.0%
	5.66 (6.3)	3.26 (6.3)	3.99 (5)	27.8%	1.11%

Note:

1. The values in parentheses represent the dose acceptance criteria.

Table 15.0-45—Fuel Handling Accident Timeline

Action	Time
Reactor shutdown (all rods in).	0 s
Fuel movement is initiated and an FHA takes place, either in the Reactor Building (with open containment) or in the Fuel Building.	34 hrs
All activity released from the gaps of fuel rods undergoing cladding failure is released to the environment (exponential release assumption).	36 hrs

**Table 15.0-46—Design Input for Fuel Handling Accident
Sheet 1 of 2**

Description		Value	References and Remarks
Source Term			
Peak assembly radial peaking factor		1.7	
Core inventory		See Table 15.0-14	
Fuel rod activity gap fractions	I-131	8%	RG 1.183, Table 3
	Other halogens	5%	
	Kr-85	10%	
	Other noble gases	5%	
	Alkalis (Cs, Rb)	12%	
Decay time prior to PA		34 hrs	Selected value to yield approximately 90% of the dose limit at the worst-case receptor.
Fuel damage resulting from PA		1 Assembly	Bounds the value in similar B&W 15x15 fuel assembly designs
Percent of damaged-fuel rod gap activity release		100%	RG 1.183, Appendix B
Atmospheric Release Resulting from Postulated FHA in Primary Containment			
Primary containment configuration during refueling operations		Open	Desired configuration
Water depth above top of fuel in refueling cavity		≥23 ft	Proposed TS requirement
Overall pool decontamination factor	Noble gases	1	RG 1.183, Appendix B
	Halogens	200	
	Alkalis	Infinite	
Composition of airborne halogens above cavity	Elemental	57%	RG 1.183, Appendix B
	Organic	43%	
Release point to atmosphere		Base of vent stack	
Exhaust filtration		None credited	
Atmospheric Release Resulting from Postulated FHA in the Fuel Building			
Water depth above top of fuel in refueling cavity		≥23 ft	Proposed TS requirement
Overall pool decontamination factor		See FHA in open containment	
Composition of airborne halogens above pool			
Release point to atmosphere		Base of vent stack	
Exhaust filtration		None credited	

**Table 15.0-46—Design Input for Fuel Handling Accident
Sheet 2 of 2**

Description	Value	References and Remarks
Other Variables		
Offsite receptor variables.	See Table 15.0-19	
MCR variables.	See Table 15.0-18	MCR isolation actuated by high rad signal in air intake duct.
MCR composite (χ/Q)s and intake filter bypass fractions for releases via MSRTs and silencers.	See Table 15.0-47	

Table 15.0-47—MCR Composite (χ/Q)s and Filter-Bypass Fractions for FHA Releases

Time Interval (hrs)		SAB Division 3 Intake (Main Flow)		SAC Division 3 Intake (Unfiltered Inleakage)		Composite χ/Q (s/m ³)	Filter Bypass Fraction
Start	End	χ/Q (s/m ³)	Flow (cfm)	χ/Q (s/m ³)	Flow (cfm)		
0	0.0167 (1 min)	1.93E-03	1500	4.30E-03	50	2.01E-03	1.00E+00
0.0167	2	1.93E-03	1000	4.30E-03	50	2.04E-03	1.00E-01
2	8	1.73E-03	1000	3.71E-03	50	1.82E-03	9.68E-02
8	24	6.74E-04	1000	1.46E-03	50	7.11E-04	9.77E-02
24	96	5.12E-04	1000	1.12E-03	50	5.41E-04	9.86E-02
96	720	4.72E-04	1000	1.03E-03	50	4.99E-04	9.84E-02

Table 15.0-48—FHA Dose Summary

Location	TEDE Dose (rem)
EAB	5.62 (6.3) ¹
LPZ	1.04 (6.3)
MCR	0.50 (5)

Note:

1. The values in parentheses represent the dose acceptance criteria.

Table 15.0-49—LOCA Radiological Sequence of Events Post-LOCA

Event	Time
LOCA with concurrent LOOP. Primary containment in purge mode. RCS activity instantly released to containment atmosphere.	0
Containment purge (at sonic flow as a result of the LOCA) automatically terminated by PCIS. Primary containment leakage initiates at 0.25% per day.	10 s
Onset of gap inventory release from core, and initiation of ESF component leakage.	30 s
Initiation of annulus, Safeguard Building and Fuel Building drawdown time. MCR emergency filtration automatically actuated (by PCIS).	60 s
Termination of building drawdown time, and ensuing termination of unfiltered releases to the atmosphere via all release pathways. Releases continue via the vent stack, and are filtered.	305 s
Termination of gap release, and onset of early in-vessel core inventory release.	0.5 hr
Worst 2-hr interval for atmospheric releases initiates.	1.4 hrs
Termination of early in-vessel release.	1.8 hrs
Primary containment leakage reduced by 50%.	24 hrs
Depletion of airborne elemental iodine inside containment as a result of natural deposition terminates (DF of 100 attained).	82 hrs (approx.)
End of analysis.	720 hrs

Table 15.0-50—LOCA Inputs
Sheet 1 of 3

Description		Value	References and Remarks
Source Term and Release Fractions			
Reactor power level		4612 MWt	
Core inventory		See Table 15.0-14	
Pre-accident RCS coolant concentrations		See Table 15.0-15	
Radionuclide groupings, and fractional releases from core during the gap and early-in-vessel release phases		RG 1.183, Table 2	
Coolant mass in RCS and pressurizer		6.47E+05 lb _m (2.935E+08 gm)	
Iodine species composition in RCS		RG 1.183, Appendix A, Section 5.5	
Iodine species composition upon release from fuel		RG 1.183, Section 3.5	
Source term for ESF component leakage		Iodines accumulating in IRWST as a result of natural deposition, and noble-gas progeny products generated therein	
Primary Containment Leakage Pathway			
Primary containment volume		2.8E+06 ft ³	
Pre-isolation unfiltered purge flow rate and duration (atmospheric release of post-LOCA primary containment airborne radioactivity prior to core damage).		100 air changes per day (based on sonic flow via 20" line), for 10 seconds	
Primary containment design temperature		338°F	
Post-LOCA iodine and aerosol removal by sprays		Not credited	
Model for natural deposition decontamination coefficients for aerosols and elemental iodines		See Table 15.0-52	RADTRAD Code
Primary containment leakage to annulus	0–24 hours	0.25% per day	
	> 24 hrs	0.125% per day	RG 1.183, Appendix A, Section 3.7
Annulus characteristics (drawdown time, mixing and exhaust filtration)			
Primary containment leakage bypassing annulus		0	Conservative assumption
Drawdown time		305 s	

Table 15.0-50—LOCA Inputs
Sheet 2 of 3

Description		Value	References and Remarks
Release point to atmosphere (ground-level releases in all cases)	During purge	Vent stack base, without filtration credit	
	During annulus 305 s drawdown time	Adjacent to SG 3 silencer, unfiltered	
	After end of drawdown	Vent stack base, with 99% filtration	
IRWST pH control		Yes	
ESF Component Leakage Pathway			
Post-LOCA liquid dilution volume	RCS coolant volume adjusted to a density of 1 g/cc (0.001602 ft ³ /lb _m)	9522 ft ³	594,400 lb _m
	Pressurizer liquid volume adjusted to a density of 1 g/cc (0.001602 ft ³ /lb _m)	839 ft ³	
	IRWST minimum required water vol.	66,886 ft ³	
	Accumulator minimum water volume (4 accumulators)	1236 ft ³ /accumulator	
	Extra-borating system volume (2 tanks)	2526.4 ft ³	
	Total (RCS + Pressurizer + IRWST + 4 accumulators + 2 EBS tanks)	8.47E+04 ft ³	
ESF component leakage rate to Safeguard Building and Fuel Building	Limiting value	≤2 gpm total	License Commitment to NUREG 0737, Item III.D.1.1
	Analysis value (twice the limiting value)	4 gpm total	RG 1.183, App. A, Section 5.2
ESF leakage flashing fraction (i.e., fraction of iodine in the liquid which becomes airborne)		10%	RG 1.183, App. A, Section 5.5
Drawdown time (Safeguard Building and Fuel Building)		305 s	
Release point to atmosphere (ground-level releases in all cases)	During 305-s building drawdown time	Adjacent to SG 3 silencer, unfiltered	
	After end of drawdown	Vent stack base, with 99% filtration	

**Table 15.0-50—LOCA Inputs
Sheet 3 of 3**

Description	Value	References and Remarks
Other Variables		
Offsite receptor variables	See Table 15.0-19	
MCR variables	See Table 15.0-18	MCR isolation actuated by PCIS
MCR composite χ/Q_s and intake filter bypass fractions for both release pathways	See Table 15.0-51	

Table 15.0-51—MCR Composite χ/Q and Filter-Bypass Fractions LOCA Releases at the Vent Stack Base¹

Time Interval		Release Pathway	SAB Div. 3 Intake (Main Flow)		SAC Div. 3 Intake (Unfiltered Inleakage)		Composite χ/Q (s/m ³)	MCR Filter Bypass Fraction
Start	End		χ/Q (s/m ³)	Flow (cfm)	χ/Q (s/m ³)	Flow (cfm)		
0	60 s	Unfiltered purge and leakage during drawdown, near SG 3 silencer.	4.30E-03	1.50E+03	1.76E-02	5.00E+01	4.73E-03	1.00E+00
60 s	305 s		4.30E-03	1.00E+03	1.76E-02	5.00E+01	4.93E-03	1.70E-01
305 s	1.5 hrs	Post drawdown primary containment filtered leakage via vent stack.	1.73E-03	1.00E+03	3.71E-03	5.00E+01	1.82E-03	9.68E-02
1.5 hrs	3.5 hrs		1.93E-03	1.00E+03	4.30E-03	5.00E+01	2.04E-03	1.00E-01
3.4 hrs	8 hrs		1.73E-03	1.00E+03	3.71E-03	5.00E+01	1.82E-03	9.68E-02
8 hrs	24 hrs		6.74E-04	1.00E+03	1.46E-03	5.00E+01	7.11E-04	9.77E-02
24 hrs	96 hrs		5.12E-04	1.00E+03	1.12E-03	5.00E+01	5.41E-04	9.86E-02
96 hrs	720 hrs		4.72E-04	1.00E+03	1.03E-03	5.00E+01	4.99E-04	9.84E-02

Note:

1. The composite χ/Q and filter bypass fractions apply to both release points (PC leakage and ESF component leakage).

Table 15.0-52—Effective Natural Deposition Decontamination Coefficients¹

Time Interval (hrs)		Deposition Factor for Elemental Iodines ² and other Particulates (hr ⁻¹)
Start	End	
0	0.00833 (30 s)	0.0
0.00833	1.8	0.032
1.8	3.8	0.092
3.8	13.8	0.128
13.8	22.2	0.086
22.2	37.5	0.0529
37.5	56.9	0.0407
56.9	82	0.0314
82	109.7	0.025
109.7	239.2	0.0138
239.2	720	0.00565

Note:

1. Based on the Powers and Henry models in RADTRAD, Reference 16, Section 2.2.2.1, 10% probability level for the Powers model up to 22.2 hrs, and the Henry model thereafter.
2. Natural deposition factors for the elemental iodines were conservatively assumed to be the same as for the particulates. Iodine depletion is terminated when a DF of 100 is attained.

Table 15.0-53—Radiological Consequences of U.S. EPR Design Basis Accidents (rem TEDE)

Design Basis Accident	Offsite Dose		Control Room Dose
	EAB	LPZ	
LOCA	12.2 (25) ¹	11.1 (25)	4.0 (5)

Note:

1. The values in parentheses represent the dose acceptance criteria.

Table 15.0-54—IRWST pH Analysis Inputs

Description		Value	References and Remarks
General			
Mass of TSP dodecahydrate needed to maintain the IRWST pH greater than 7 for 30 days post-LOCA		12,200 lb _m	
Hypalon cable jacket mass in containment		100,000 lb _m	
Hypalon dimensions and density	Inner diameter	1.8948 cm	
	Outer diameter	2.2608 cm	
	Density	1.55 g/cc	
Ethylene-propylene rubber protected by Hypalon	Inner diameter	1.4580 cm	
	Outer diameter	1.8948 cm	
	Density	1.27 g/cc	
Fraction of cable in conduit		None	Conservative
Fraction of cable in cable trays		All	Conservative
PVC cable mass in containment		4000 lb _m	
Paint film surface area in containment		7.0E+05 ft ²	
Water volume in postaccident IRWST (excludes RCS and accumulator volumes – see Item C1)	Minimum	66,886 ft ³	
	Maximum (Calculated)	69,865 ft ³	
Containment free volume	Minimum	2.8E+06 ft ³	
IRWST initial boron concentration at time of postulated LOCA		1900 ppm	
IRWST temperature range during normal operation		59 to 122°F	
Extra-borating system volume (2 tanks)		1908 ft ³	
EBS boron concentration		7000 to 7300 ppm	

Table 15.0-55—H⁺ Added to IRWST

Time	HNO ₃ (mol/L)	HCl - Hypalon ¹ (mol/L)	HCl - PVC ¹ (mol/L)	H ⁺ (Σ col. 2-4) (mol/L)
1h	3.51E-06	9.98E-05	1.47E-05	1.18E-04
2h	4.83E-06	1.70E-04	2.49E-05	2.00E-04
5h	7.57E-06	3.26E-04	4.78E-05	3.81E-04
12h	1.21E-05	5.79E-04	8.50E-05	6.76E-04
1d	1.80E-05	8.94E-04	1.31E-04	1.04E-03
3d	5.16E-05	1.45E-03	2.13E-04	1.71E-03
10d	1.14E-04	2.45E-03	3.59E-04	2.92E-03
20d	1.53E-04	2.95E-03	4.33E-04	3.54E-03
30d	1.78E-04	3.21E-03	4.70E-04	3.86E-03

Note:

1. 100,000 lb_m of Hypalon jacket + 4000 lb_m of PVC jacket.

Table 15.0-56—Mass of TSP vs. pH at 30 Days

Mass TSP (lb _m)	PO ₄ (mol/L)	Starting pH	pH at 30 days
12,200	0.0061	7.5	7.1

**Table 15.0-57—TMI Action Plan Items
Sheet 1 of 2**

Item #	Subject	Disposition for U.S. EPR
I.C.1	NUREG-0737, I.C.1, Short-Term Accident Analysis and Procedures Revision	This requirement is satisfied by the emergency procedure guidelines (EPGs), as described in Section 13.5, Plant Procedures.
II.B.3	10 CFR 50.34(f)(2)(viii) Post Accident Sampling Capability	This requirement is satisfied by the severe accident sampling system (SASS), Section 9.3.2, Process Sampling Systems.
II.E.1.1	10 CFR 50.34(f)(1)(ii) Evaluation of the Auxiliary Feedwater (AFW) System	The required reviews are performed for the emergency feedwater system (EFW), including a failure modes and effects assessment, as described in Section 10.4.9, Emergency Feedwater System.
II.E.1.2	10 CFR 50.34(f)(2)(xii) AFW Initiation and Flow Indication	The required EFW functionality and indications are presented in: <ul style="list-style-type: none"> ● Section 7.5, Information Systems Important to Safety. ● Section 10.4.9, Emergency Feedwater System. ● Section 18.7.1.3, Regulatory Requirements.
II.E.5.1	10 CFR 50.34(f)(2)(xvi) ECCS and PS Actuation Cycles	Not applicable to the U.S. EPR (applicable to B&W designs only).
II.F.1	10 CFR 50.34(f)(2)(xvii) Post-Accident Measurement and Sampling	The required functionality is provided, as presented in: <ul style="list-style-type: none"> ● Section 6.2.5, Combustible Gas Control in Containment. ● Section 7.5, Information Systems Important to Safety ● Section 11.5, Process and Effluent Radiological Monitoring and Sampling Systems ● Section 18.7.1.3, Regulatory Requirements.
II.F.2	10 CFR 50.34(f)(2)(xviii) Instrumentation for Detecting Inadequate Core Cooling	The required functionality is provided by reactor vessel water level indication and a combination of RCS hot leg wide range pressure and the core outlet Thermocouples, as described in Section 7.5, Information Systems Important to Safety.
II.F.3	10 CFR 50.34(f)(2)(xix) Instrumentation for Monitoring Plant Conditions, including core damage	The postaccident monitoring variables and the severe accident monitoring variables provide for monitoring plant conditions following core damage, Sections 7.5, Information Systems Important to Safety, and 18.7.1.3, Regulatory Requirements.

**Table 15.0-57—TMI Action Plan Items
Sheet 2 of 2**

Item #	Subject	Disposition for U.S. EPR
II.K.2.16	10 CFR 50.34(f)(1)(iii) Reactor Coolant Pump Seal Damage for SBLOCA	Shaft seal integrity is provided by maintaining cooling to the RCP shaft seal during a SBLOCA coincident with LOOP, as presented in: <ul style="list-style-type: none"> • Section 5.4.1, Reactor Coolant Pumps. • Section 9.2, Water Systems • Section 15.6.5.2, Small Break Loss of Coolant Accident.
II.K.2.17	Voiding in the reactor vessel and the hot legs during normal anticipated transients (See item I.C.1).	Requirements are satisfied by the EPGs, Section 13.5, Plant Procedures.
II.K.3.1	Auto PORV Isolation	The U.S. EPR has pressurizer safety valves that incorporate relief capability. Because of the safety function, they are not isolatable (refer to Section 5.4.13, Safety and Relief Valves).
II.K.3.5	Auto Trip of RCPs	The required functionality is provided through an automated trip of the RCPs on the combination of a safety injection signal and low pressure differential across the pumps, as provided in Section 7.3.1.2.15, Reactor Coolant Pump Trip and Section 15.6.5.2, Small Break Loss of Coolant Accident.
II.K.3.7	Evaluation of PORV Opening Probability	The U.S. EPR design does not use a power-operated relief valve to prevent primary system overpressure during power operation. The U.S. EPR PSRVs use spring-loaded pilot valves to open the main relief valves during power operation. While power-operated pilot valves open the PSRVs, they are used only in shutdown modes for low-temperature overpressure protection.
II.K.3.13	10 CFR 50.34(f)(1)(iii) HPCI and RCIC Initiation Levels	Not applicable to the U.S. EPR (applicable to BWRs only).
II.K.3.30	Small break LOCA methodology	The methodology used to evaluate small break LOCA is approved by the NRC, Reference 3.
II.K.3.31	Compliance with 10 CFR 50.46	The U.S. EPR complies with the requirements of 10 CFR 50.46. The methodology used to evaluate small break LOCA is approved by the NRC, Reference 3.
II.K.3.44	Evaluate Transients Considering Single Failures	The analyses of the transients presented in Chapter 15 consider single failures as required and described in Section 15.0.0.3.8, Limiting Single Failures
II.K.3.45	10 CFR 50.34(f)(1)(xi) Depressurization Methods	Not applicable to the U.S. EPR (applicable to BWRs only).

Table 15.0-58—Unresolved Safety Issues

USI #	Subject	Disposition for U.S. EPR
USI-A-9	Anticipated Transients Without Scram	USI A-9 was resolved with the publication of a final rule (10 CFR 50.62). The U.S. EPR complies with the requirements of 10 CFR 50.62 as described in Section 15.8, Anticipated Transients Without Scram.
USI-A-47	Safety Implications of Control Systems	The U.S. EPR design addresses Action (1) of this issue through the EFW system, which reduces the likelihood of SG dryout. The DCS prevents SG overflow by isolating the EFW on high SG level. Action (2) is addressed through TSs that verify the operability of the EFW and DCS. Action (3) is addressed through EPGs, Section 13.5, Plant Procedures.
USI-B-17	Safety-Related Operator Actions	U.S. EPR credits operator action to mitigate few Chapter 15 events and then, only after 30 minutes. These operator actions are incorporated into the EPGs, Section 13.5, Plant Procedures.
USI-C-4	Statistical Methods for ECCS Analyses	The U.S. EPR uses an NRC approved statistical methodology to evaluate large break LOCA, Reference 4.
USI-C-5	Decay Heat Model Update	USI-C-5 states that the NRC “staff has determined that the 1979 ANSI/ANS Standard 5.1 is technically acceptable and has allowed the use of this data to justify relaxation of non-required conservatism in current ECCS evaluation models.” The 1973 ANSI/ANS 5.1 decay heat standard is used for the evaluation of small break LOCA, Reference 3. The 1979 ANSI/ANS 5.1 decay heat standard is used for the evaluation of large break LOCA, Reference 4.
USI-C-6	LOCA Heat Source	The NRC approved methodologies for evaluating large break and small break LOCA (References 3 and 4) account for effects of power density, decay heat, stored energy, fission power decay, and their associated uncertainties as required.
USI-C-10	Effective Operation of Containment Spray	An automatically actuated containment spray system is not required to mitigate the consequences of a DBA, as presented in: <ul style="list-style-type: none"> ● Section 6.2, Containment Systems. ● Section 6.5.2, Containment Spray Systems. ● Section 15.0.3, Radiological Consequences of Design Basis Accidents.

**Table 15.0-59—Generic Safety Issues
Sheet 1 of 2**

GSI #	Subject	Disposition for U.S. EPR
GSI-3	Instrumentation Setpoint Drift	Setpoint drift is accounted for in the uncertainties used for Chapter 15 analyses, as described in Section 7.2.2.3.7, Compliance with Requirements for RT Setpoint Determination (Clause 6.8 of IEEE Std 603-1998), and Section 7.3.2.3.8, Compliance with Requirements for ESF Actuation Setpoint Determination (Clause 6.8 of IEEE Std 603-1998).
GSI-22	Detection of boron dilution events during shutdown and refueling	This requirement is satisfied through a safety-related system that monitors boron concentration in the RCS and isolates the CVCS if boron dilution is detected (refer to Section 15.4.6, Chemical and Volume Control System Malfunction that Results in a Decrease in the Boron Concentration in the Reactor Coolant).
GSI-23	Reactor Coolant Pump Seal Failure	This issue is addressed by the U.S. EPR RCP shaft seal system that consists of a series of three seals and a standstill seal. The shaft seal design provides redundancy so that a failure of a single seal stage will not cause an uncontrolled loss of reactor coolant. The standstill seal is a metal-to-metal contact seal that prevents leakage when the RCP is stopped and the three seal leak off lines have been isolated (refer to Section 5.4.1.2.1).
GSI-24	Automatic ECCS Suction Switchover to Recirculation Mode	This requirement is not applicable to the U.S. EPR. The source of safety injection water is the IRWST, which functions as the sump (refer to Section 6.3, Emergency Core Cooling System). Therefore, there is no need for a switchover to recirculation mode.
GSI-40	BWR Scram System Pipe Break	Not Applicable to the U.S. EPR (applicable to BWRs only).
GSI-75	Generic Implications of ATWS	The design of the U.S. EPR addresses this issue. Any one of three diverse sets of RT devices can successfully remove power to the CRDM coils. When an RT order is generated, the DCS acts on the Reactor Trip Breakers and Reactor Trip Contactors (refer to Section 7.2, Reactor Trip System). The U.S. EPR satisfies the requirements of 10 CFR 50.62.
GSI-125. II.7	Reevaluate Provision to Automatically Isolate Feedwater from Steam Generator During a Line Break	The U.S. EPR design addresses this issue. EFW is not isolated on low SG pressure. The DCS only isolates EFW automatically in individual SGs when a high SG level signal is reached (refer to Section 7.3.1.2.3, Emergency Feedwater System Isolation). The DCS automatically reinitiates EFW on low level.

**Table 15.0-59—Generic Safety Issues
Sheet 2 of 2**

GSI #	Subject	Disposition for U.S. EPR
GSI-135	Steam Generator and Steam Line Overfill	The thermal-hydraulic evaluation of an SGTR is presented in Section 15.6.3, Steam Generator Tube Failure (PWR). The affected steam generator does not overfill and cause liquid to enter the steam line. The corresponding radiological evaluation is presented in 15.0.3.6, Steam Generator Tube Rupture Accident.
GSI-185	Control of Recriticality Following SBLOCAs	This issue is addressed in Section 15.6.5.4.2, SBLOCA Boron Dilution.
GSI-191	PWR Sump Clogging	The U.S. EPR design incorporates mitigative features such as reflective metal insulation and filtering devices described in Section 6.3.2.5, System Reliability, to address this issue.

**Table 15.0-60—NRC Generic Letters
Sheet 1 of 2**

GL #	Subject	Disposition for U.S. EPR
GL-80-19	Resolution of Enhanced Fission Gas Release Concern	This GL is satisfied for the U.S. EPR. Fission gas release at extended burnups is calculated by the fuel performance computer codes COPERNIC, RODEX2 and RODEX3 described in References 3 and 4.
GL-80-35	Effect of a DC Power Supply Failure on ECCS Performance	The U.S. EPR design addresses this concern by providing four independent trains of ECCS. The evaluation of LOCA events, Section 15.6, Decrease in Reactor Coolant Inventory Events, conservatively assumes one train of MHSI, LHSI and EFW is unavailable because of maintenance, a second train is unavailable because of a single failure and a third train is in the broken cold leg.
GL-83-11	Licensee Qualification for Performing Safety Analysis in Support of Licensing Actions	This GL is satisfied for the U.S. EPR. AREVA is qualified to perform safety analysis as demonstrated by NRC’s approval of the methodologies developed by AREVA that are used to evaluate the U.S. EPR.
GL-83-22	Safety Evaluation of ‘Emergency Response Guidelines’	This item is addressed by the emergency procedure guidelines (EPGs), Section 13.5, Plant Procedures.
GL-83-32	NRC Staff Recommendations Regarding Operator Action for Reactor Trip and ATWS	The U.S. EPR complies to the requirements of 10 CFR 50.62 as described in Section 15.8, Anticipated Transients Without Scram.
GL-85-06	Quality Assurance Guidance for ATWS Equipment That Is Not Safety-Related	The quality assurance requirements for ATWS equipment described in Addendum A-19 of AREVA NP Topical Report ANP-10266A, “AREVA NP Quality Assurance Plan for Design Certification of the U.S. EPR” apply to the DAS, Section 7.1.1.4.7, Diverse Actuation System (DAS). (Reference 19)
GL-85-16	High Boron Concentrations	The U.S. EPR design addresses this concern. The MHSI and LHSI pumps take suction from the IRWST, which does not contain boron concentrations high enough to be susceptible to precipitation. An independent, manually initiated, safety-related Extra Borating System, Section 6.8, provides highly borated injection for maintaining reactivity margin during plant cooldown to cold shutdown. It is designed to avoid crystallization issues, Section 6.8.2, System Description.
GL-86-13	Potential Inconsistency between Plant Safety Analyses and Technical Specifications	The potential for inconsistency between the U.S. EPR TSs and Chapter 15 analyses is avoided because safety analysis evaluated the complete operating domain from power operation to cold shutdown and the TS are based on this safety analysis.

**Table 15.0-60—NRC Generic Letters
Sheet 2 of 2**

GL #	Subject	Disposition for U.S. EPR
GL-86-16	Westinghouse ECCS Evaluation Models	This issue only applies to the Westinghouse evaluation models, and is not applicable to the U.S. EPR.
GL-88-16	Removal of Cycle-Specific Parameter Limits from Technical Specifications	Fuel cycle specific parameter information is provided in the Core Operating Limits Report.
GL-88-17	Loss of Decay Heat Removal	The U.S. EPR design addresses this concern through the automatic actuation of MHSI on a low RCS loop level signal during non-power operation. The actuation of MHSI is adequate to maintain RCS inventory in the event of the loss of the RHR system, Section 7.3.1.2.1, Safety Injection System Actuation.
GL-93-04	Rod Control System Failure and Withdrawal of Rod Control Cluster Assemblies	This letter describes a Westinghouse control system issue. The corresponding U.S. EPR rod control system, the Reactor Control, Surveillance and Limitation System, Section 7.1.1.4.5, is designed to prevent a single failure from causing a loss of function. Moreover, reactivity events such as described in the letter are evaluated in Section 15.4, Reactivity and Power Distribution Anomalies.
GL-97-01	Degradation of Control Rod Drive Mechanism Nozzle and Other Vessel Closure Head Penetrations	Control rod ejection is evaluated from a reactivity standpoint in Section 15.4.8. A failure in the reactor vessel head penetration that causes a small break LOCA is bounded by the analyses in Section 15.6.5.2.
GL-98-02	Loss of Reactor Coolant Inventory and Associated Potential for Loss of Emergency Mitigation Functions while in a Shutdown Condition	The safety injection system (SIS), which provides the emergency core cooling function for the U.S. EPR, comprise of four supply and return trains, one for each of the reactor coolant system (RCS) loops. Since the SIS does not use a common pump suction header for its emergency core cooling function, a common-cause failure is precluded. Also, design features that result in an inadvertent RCS draindown, such as the spurious opening of the LHSI suction isolation valve during residual heat removal, is discussed in the failure modes and effects analysis (FMEA), Section 6.3, Emergency Core Cooling System.
GL-2004-02	Potential Impact of Debris Blockage on Emergency Recirculation During Design Basis Accidents at Pressurized-Water Reactors	The U.S. EPR design incorporates mitigative features to address this concern such as reflective metal insulation and filtering devices described in Section 6.3.2.5, System Reliability.

**Table 15.0-61—NRC Bulletins
Sheet 1 of 2**

BL #	Subject	Disposition for U.S. EPR
BL-80-04	Analysis of a PWR Main Steam Line Break with Continued Feedwater Addition	The U.S. EPR addresses this concern through design features that isolate MFW in events such as a MSLB. The full-load MFW line is isolated on an RT. When the low-low SG pressure or high-high SG pressure decrease setpoint is reached, the DCS automatically isolates the low-load feedwater line in the affected SG. EFW is not isolated for these events. MSLB is evaluated in Sections 15.1.5, Steam System Piping Failures Inside and Outside of Containment (PWR), and 6.2.1.4, Mass and Energy Release Analysis for Postulated Secondary Pipe Ruptures inside Containment.
BL-80-12	Decay Heat Removal System Operability – The bulletin describes a concern that redundancy in DHR capability is reduced because of maintenance activities and inadequate administrative control	The U.S. EPR addresses this concern by providing four independent, redundant trains of the RHR system. One train is adequate to provide core cooling. TSs provide the administrative controls to maintain the necessary heat removal capability.
BL-80-18	Maintenance of Adequate Minimum Flow thru Centrifugal Charging Pumps Following Secondary Side High Energy Line Rupture	The U.S. EPR design avoids this issue by having separate charging pumps and safety injection pumps. The MHSI system includes a mini-flow line that provides adequate recirculation to prevent overheating of the pump, Section 6.3.2.2, Equipment and Component Descriptions. This mini-flow line is open during plant operation.
BL-86-03	Potential Failure of Multiple ECCS Pumps due to Single Failure of Air-operated Valve in Minimum Flow Recirculation Line	The U.S. EPR design avoids this issue by having four independent trains of ECCS.
BL-93-02	Debris Plugging of Emergency Core Cooling Suction Strainers – Fibrous air filters and other temporary material appear to be likely sources of such fibrous material.	The U.S. EPR design incorporates filtering devices described in Section 6.3.2.5, System Reliability, to address this issue. The plant licensee is responsible for the control of foreign materials brought into the containment.
BL-95-02	Unexpected Clogging of a Residual Heat Removal (RHR) Pump Strainer while Operating in Suppression Pool Cooling Mode	The U.S. EPR design incorporates filtering devices described in Section 6.3.2.5, System Reliability, to address this issue. The plant licensee is responsible for the control of foreign materials brought into the containment.

**Table 15.0-61—NRC Bulletins
Sheet 2 of 2**

BL #	Subject	Disposition for U.S. EPR
BL-96-01	Control Rod Insertion Problems – operability of control rods in high burnup fuel assemblies	The U.S. EPR fuel assembly does not experience permanent deformations during AOOs that cause the control component drop time to increase beyond the drop time acceptance criterion. This criterion is met by demonstrating the fuel assembly guide tubes remain elastic under all operating conditions (refer to Section 4.2.1.5.10, Control Rod Trip Times).
BL-96-03	Potential Plugging of Emergency Core Cooling Suction Strainers by Debris in Boiling Water Reactors	The U.S. EPR design incorporates filtering devices described in Section 6.3.2.5, System Reliability, to address this issue. The plant licensee is responsible for the control of foreign materials brought into the containment.
BL-2001-01	Circumferential Cracking of Reactor Pressure Vessel Head Penetration Nozzles	Control rod ejection is evaluated from a reactivity standpoint in Section 15.4.8. A failure in the reactor vessel head penetration that causes a small break LOCA is bounded by the analyses in Section 15.6.5.2

Table 15.0-62—Transient Analysis Limiting Cases
Sheet 1 of 4

Event	Acceptance Criteria Evaluated	Limiting Case
15.1 Increase in Heat Removal by Secondary System		
Decrease in feedwater temperature	SAFDLs RCS and SG pressure	HFP EOC manual rod control with LOOP, DNB is limiting criteria. RCS and SG pressure limits are not challenged.
Increase in feedwater flow	SAFDLs RCS and SG pressure	HFP BOC automatic rod control with LOOP, DNB is limiting criteria. RCS and SG pressure limits are not challenged.
Increase in steam flow	SAFDLs RCS and SG pressure	HFP EOC automatic rod control with LOOP, 50% steam flow increase, DNB is limiting criteria. RCS and SG pressure limits are not challenged.
Inadvertent opening of a SG relief or safety valve	SAFDLs RCS and SG pressure	HFP EOC manual rod control with LOOP, DNB is limiting criteria. RCS and SG pressure limits are not challenged.
Steam system piping failure	SAFDLs RCS and SG pressure	HFP EOC 1.72 ft ² break with offsite power available. DNB is limiting criteria. RCS and SG pressure limits are not challenged.
15.2 Decrease in Heat Removal by Secondary System		
Turbine Trip	SAFDLs RCS and SG pressure	HFP BOC with LOOP, limiting RCS pressure event. SAFDL and SG pressure limits are not challenged.
Closure of a MSIV	SAFDLs RCS and SG pressure	HFP EOC, limiting SG pressure event. SAFDL and RCS pressure limits are not challenged.
Loss of non-emergency AC power	SAFDLs RCS and SG pressure	Not specifically analyzed. Event is bounded by Complete Loss of flow for DNB and Loss of normal feedwater for RCS and SG pressure criteria.

Table 15.0-62—Transient Analysis Limiting Cases
Sheet 2 of 4

Event	Acceptance Criteria Evaluated	Limiting Case
Loss of normal feedwater flow	SAFDLs RCS and SG pressure Decay heat removal Pressurizer overfill	HFP BOC, for decay heat removal (minimum SG inventory) HFP EOC with pressure control and LOOP for pressurizer overfill HFP BOC, no pressure control with LOOP for RCS pressure SAFDLs and SG pressure limits are not challenged.
Feedwater system pipe break	SAFDLs RCS and SG pressure Decay heat removal Pressurizer overfill	HFP BOC 2% Break with LOOP pressurizer overfill HFP BOC full break decay heat removal HFP BOC 45% Break RCS pressure HFP BOC full break SG pressure SAFDLs are not challenged.
15.3 Decrease in Reactor Coolant System Flow Rate		
Partial loss of forced reactor coolant flow	SAFDLs RCS and SG pressure	HFP BOC with LOOP, DNB is limiting criteria. RCS and SG pressure limits are not challenged.
Complete loss of forced reactor coolant flow	SAFDLs RCS and SG pressure	HFP BOC, DNB is limiting criteria. RCS and SG pressure limits are not challenged.
RCP rotor seizure	SAFDLs RCS and SG pressure	HFP BOC with LOOP, DNB is limiting criteria. RCS and SG pressure limits are not challenged.
15.4 Reactivity and Power Distribution Anomaly		
Uncontrolled RCCA withdrawal from a subcritical or low power startup condition	SAFDLs RCS and SG pressure	4.59E-06% power at maximum reactivity addition rate (12 pcm/sec). DNB is limiting criteria. RCS and SG pressure limits are not challenged.
Uncontrolled RCCA bank withdrawal at power	SAFDLs RCS and SG pressure	Range of conditions analyzed including HZP, HFP, 25%, and 60%, BOC and EOC. DNB is limiting criteria. RCS and SG pressure limits are not challenged. No specific limiting case. Low DNBR trip provides protection.

Table 15.0-62—Transient Analysis Limiting Cases
Sheet 3 of 4

Event	Acceptance Criteria Evaluated	Limiting Case
Single RCCA withdrawal	SAFDLs RCS and SG pressure	System analysis performed as part of bank rod withdrawal spectrum. DNB is limiting criteria. RCS and SG pressure limits are not challenged. No specific limiting case. Low DNBR trip provides protection.
RCCA misalignment	SAFDLs	See Section 15.4.3.2
RCCA drop	SAFDLs	HFP and 90%, BOC and EOC with LOOP and automatic rod control. Spectrum of cases analyzed dropping rods and banks from 12 to 2167 pcm. DNB is limiting criteria. No specific limiting case. Low DNBR trip provides protection.
Startup of a RCP in an inactive loop	SAFDLs RCS and SG pressure	Maximum power following a partial trip (60%). This event evaluates the startup of a RCP following a partial trip. Acceptance criteria are not challenged.
Decrease in the boron concentration in the RCS	SAFDLs RCS and SG pressure	System analysis performed as part of bank rod withdrawal spectrum. DNB is limiting criteria. RCS and SG pressure limits are not challenged. No specific limiting case. Low DNBR trip provides protection. For the shutdown modes anti-dilution system provides protection to terminate the dilution prior to criticality.
Inadvertent loading and operation of a fuel assembly in an improper position	SAFDLs	See Section 15.4.7
RCCA ejection	RCS and SG pressure Fuel energy deposition limits	HZP 700 pcm ejected rod for peak RCS pressure For fuel energy deposition HFP (see Tables 15.4-17 and 15.4-18).

Table 15.0-62—Transient Analysis Limiting Cases
Sheet 4 of 4

Event	Acceptance Criteria Evaluated	Limiting Case
15.5 Increase in RCS Inventory		
Inadvertent operation of the ECCS or EBS	SAFDL Pressurizer overfill RCS pressure	HFP, BOC, manual rod control, pressure control, with LOOP. Limiting criteria is pressurizer overfill. SAFDL and RCS pressure limits are not challenged.
CVCS malfunction that increases reactor coolant inventory	SAFDL Pressurizer overfill RCS pressure	HFP, BOC, manual rod control, pressure control, with LOOP. Limiting criteria is pressurizer overfill. SAFDL and RCS pressure limits are not challenged.
15.6 Decrease in RCS Inventory		
Inadvertent opening of a pressurizer relief valve	SAFDL	HFP, BOC, manual rod control, with LOOP. Limiting criteria is DNB.
SGTR	Radiological SG Overfill	Radiological: HFP EOC 584°F Tavg, the limiting single failure is that the MSRCV sticks fully open associated with the affected SG. Overfill: HFP EOC 584°F Tavg, the limiting single failure is that the MFWFLIV for the affected SG fails to close.
Loss-of-coolant accident	10CFR50.46	LBLOCA: Statistically derived. SBLOCA: HFP 6.5 inch break with LOOP

Table 15.0-63—Transient Analysis Limiting Case Conditions⁹

Sheet 1 of 3

Event	Limiting Acceptance Criteria	Power (MW _t)	T _{avg} (°F)	RCS Flow per loop (gpm)	Pressurizer level (%)	SG Level (%)	SG Tube Plugging (%)
15.1 Increase in Heat Removal by Secondary System							
Decrease in feedwater temperature	SAFDLs	4612	594 ²	119,692 ³	54.3	49	0
Increase in feedwater flow	SAFDLs	4612	594 ²	119,692 ³	54.3	49	0
Increase in steam flow	SAFDLs	4612	594 ²	119,692 ³	54.3	49	0
Inadvertent opening of a SG relief or safety valve	SAFDLs	4612	594 ²	119,692 ³	54.3	49	0
Steam system piping failure	SAFDLs	1.0E-06	578 ²	119,692 ³	34	49	0
15.2 Decrease in Heat Removal by Secondary System							
Turbine Trip	RCS pressure	4612	594	119,692	59.3	49	5
Closure of a MSIV	SG pressure	4612	598	119,692	59.3	49	0
Loss of non-emergency AC power ¹		—	—	—	—	—	—
Loss of normal feedwater flow	RCS and SG pressure ⁸						
	Decay heat removal	4612	594	119,692	59.3	49	0
	Pressurizer overfill	4612	579	119,692	59.3	49	0
Feedwater system pipe break	RCS Pressure	4612	594	119,692	59.3	49	0
	SG pressure	4612	594	119,692	59.3	49	0
	Decay heat removal	4612	594	119,692	59.3	49	0
	Pressurizer overfill	4612	584	119,692	59.3	49	5

Table 15.0-63—Transient Analysis Limiting Case Conditions⁹

Sheet 2 of 3

Event	Limiting Acceptance Criteria	Power (MW _t)	T _{avg} (°F)	RCS Flow per loop (gpm)	Pressurizer level (%)	SG Level (%)	SG Tube Plugging (%)
15.3 Decrease in Reactor Coolant System Flow Rate							
Partial loss of forced reactor coolant flow	SAFDLs	4612	594 ²	119,692	54.3	49	5
Complete loss of forced reactor coolant flow	SAFDLs	4612	594 ²	119,692	54.3	49	5
RCP rotor seizure	SAFDLs	4612	594 ²	119,692	54.3	49	5
15.4 Reactivity and Power Distribution Anomaly							
Uncontrolled RCCA withdrawal from a subcritical or low power startup condition	SAFDLs	4.59E-06	578 ²	119,692	34	49	5
Uncontrolled RCCA bank withdrawal at power	SAFDLs	0-4612 ⁴	578-594 ²	119,692	34-54.3	49	5
Single RCCA withdrawal	SAFDLs	0-4612 ⁴	578-594 ²	119,692	34-54.3	49	5
RCCA drop	SAFDLs	4612 ⁴	594 ²	119,692	54.3	49	5
Startup of a RCP in an inactive loop ⁷		2754	594 ²	119,692	54.3	49	5
Decrease in the boron concentration in the RCS ⁵	SAFDLs	0-4612 ⁴	578-594 ²	119,692	34-54.3	49	5
RCCA ejection	RCS pressure	0	578	119,692	34	49	—
	Fuel deposition limits	4612	594	119,692	54.3	49	—

Table 15.0-63—Transient Analysis Limiting Case Conditions⁹

Sheet 3 of 3

Event	Limiting Acceptance Criteria	Power (MW _t)	T _{avg} (°F)	RCS Flow per loop (gpm)	Pressurizer level (%)	SG Level (%)	SG Tube Plugging (%)
15.5 Increase in RCS Inventory							
Inadvertent operation of the ECCS or EBS	Pressurizer overfill	4612	594	119,692	54.3	49	5
CVCS malfunction that increases reactor coolant inventory	Pressurizer overfill	4612	594	119,692	54.3	49	5
15.6 Decrease in RCS Inventory							
Inadvertent opening of a pressurizer relief valve	SAFDL	4612	594	119,692	54.3	49	5
SGTR	Radiological dose	4612	584	119,692	59.3	49	5
	SG Overfill	4612	584	119,692	59.3	49	5
Loss-of-coolant accident	10CFR50.46 LBLOCA	See Note 6	See Note 6	See Note 6	See Note 6	—	5
	10CFR50.46 SBLOCA	4612	594	119,692	54.3	49	5

Notes:

1. Not analyzed. Event is bounded by complete loss of flow for DNB and loss of normal feedwater for RCS and SG Pressure.
2. Nominal T_{avg} at full power. Operating band and measurement uncertainties on temperature and pressure are applied in the DNB analysis.
3. Thermal design flow is assumed in the system analysis for DNB limiting events.
4. No specific limiting case. Low DNBR trip provides protection.

5. This event is analyzed at power as part of the spectrum of uncontrolled rod withdrawal events. In the shutdown modes, this event establishes the setpoints for the anti-dilution mitigation system.
6. These parameters are statistically sampled. See Section 15.6.5.1.
7. Acceptance criteria are not challenged.
8. Bounded by turbine trip and MSIV closure events, respectively.
9. Parameters are selected within the allowed operating band that would produce the greatest challenge to the acceptance criteria. When the variation of a parameter has a negligible impact on the results, the nominal value is selected.

Table 15.0-64—IRWST pH vs. Acid Added

pH	H+
7.5	0.00E+00
7.4	1.24E-03
7.3	2.31E-03
7.2	3.23E-03
7.1	4.03E-03
7	4.71E-03

Table 15.0-65—IRWST pH vs. Time

Time (hours)	pH
0	7.5
48	7.38
96	7.34
144	7.30
192	7.26
240	7.23
288	7.21
336	7.2
384	7.19
432	7.18
480	7.17
528	7.16
576	7.15
624	7.14
672	7.13
720	7.12

Figure 15.0-1—RCCA Position as a Function of Time to Reach for Full Insertion

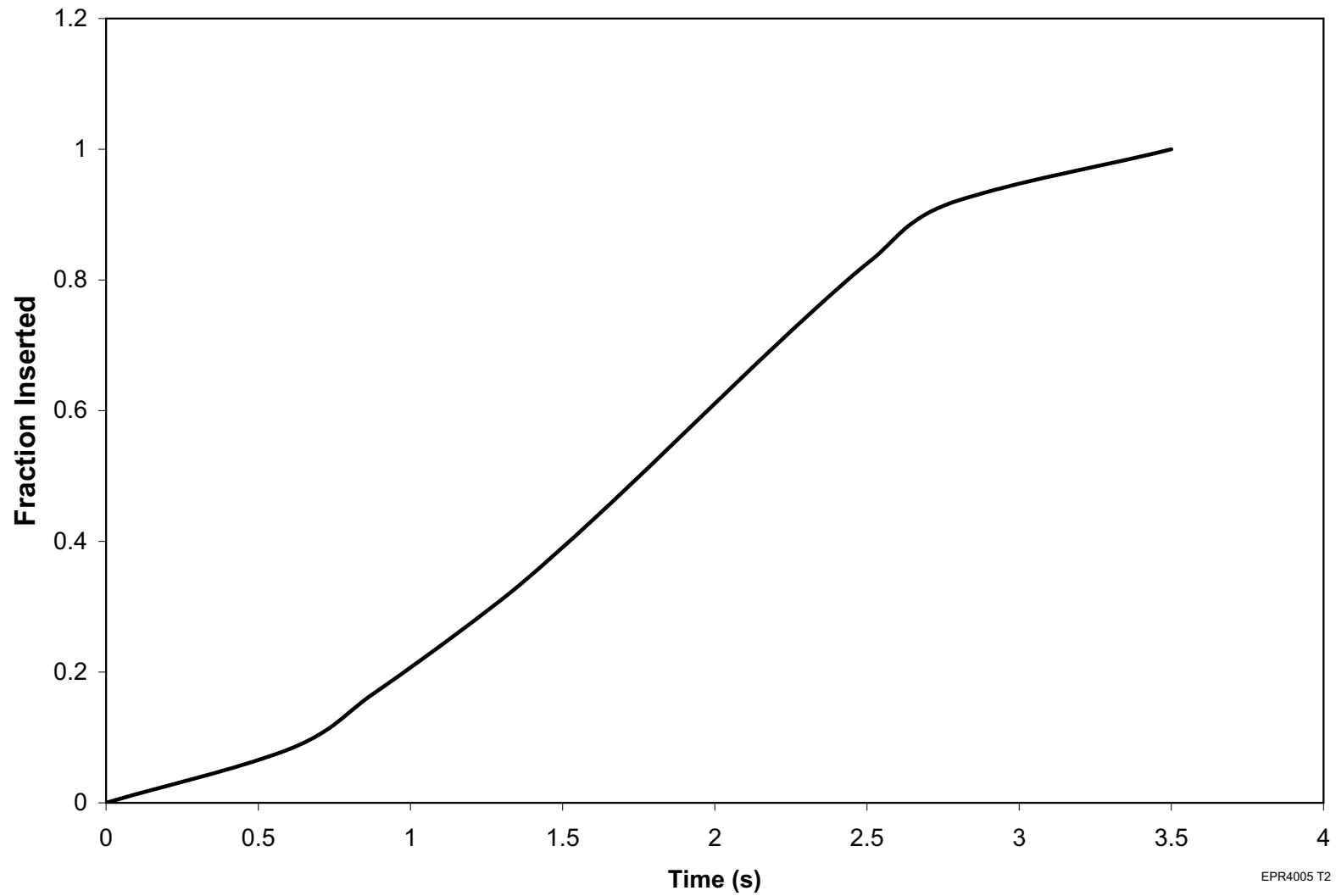

Figure 15.0-2—Normalized RCCA Rod Worth as a Function of Position Within the Core

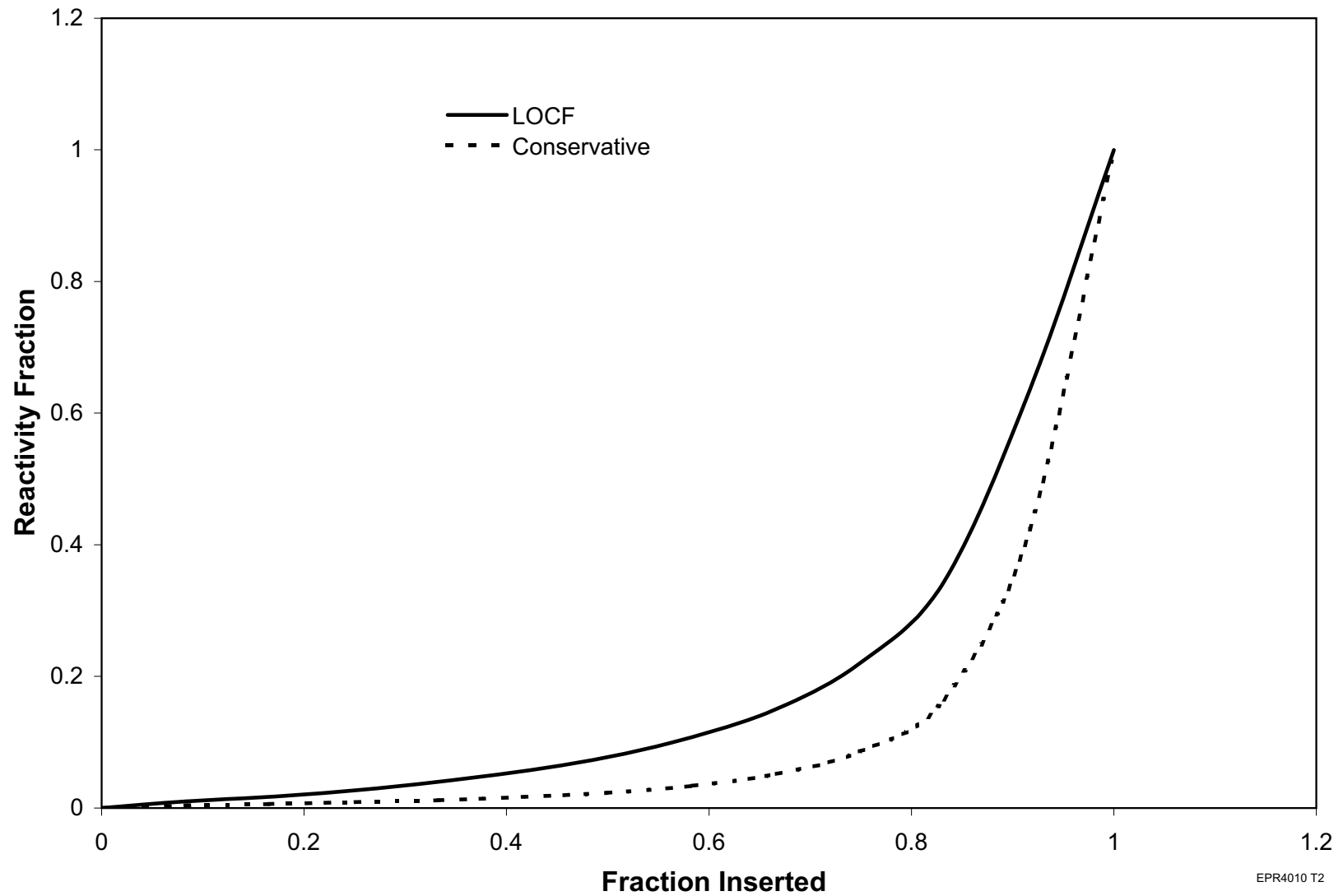
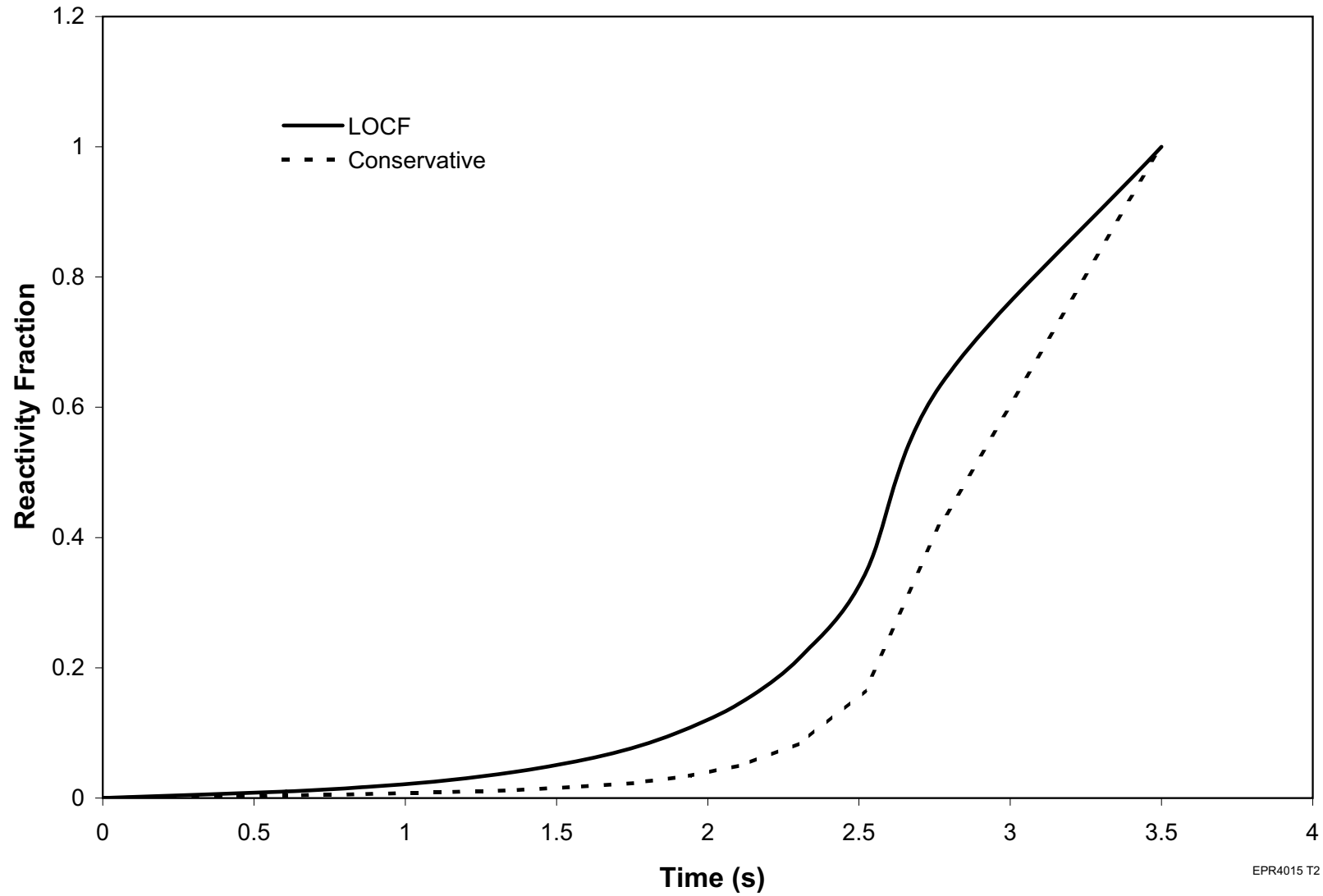
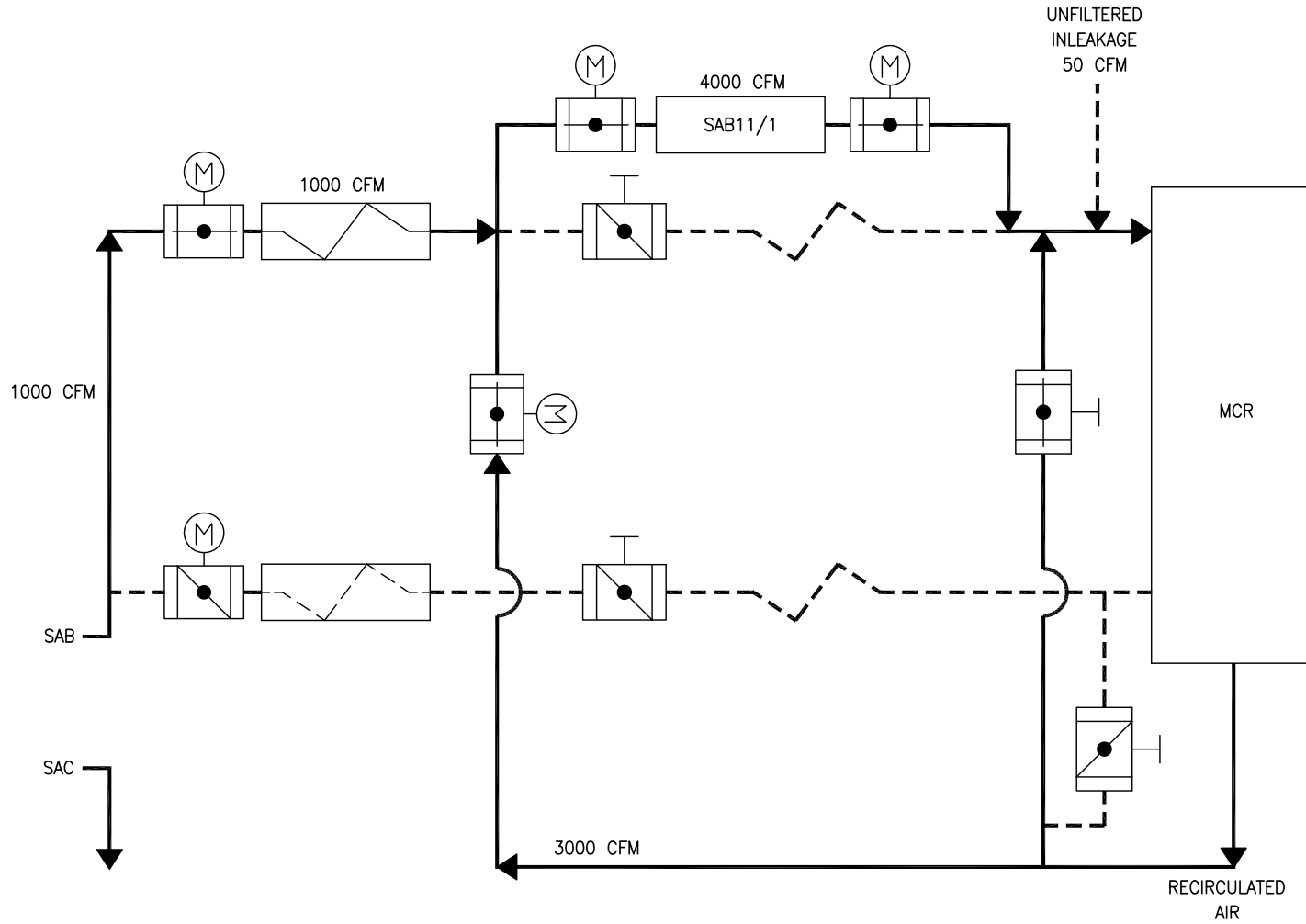

Figure 15.0-3—Normalized RCCA Reactivity Worth as a Function of Rod Drop Time



EPR4015 T2

Figure 15.0-4—MCR Envelope Post-Accident HVAC Filtration Mode Model



REV 006
EPR4020 T2

[Next File](#)