

### 3C Reactor Coolant System Structural Analysis Methods

This appendix describes the structural analysis of the reactor coolant system (RCS) and the reactor pressure vessel (RPV) internals. It addresses the development of the RCS and RPV isolated hydraulic models used to generate pipe break loading as well as the development of the RCS and RPV internals structural models used in the static and dynamic loading analyses. In addition, the hydraulics analyses that are used to generate forcing functions due to pipe break are described as are the static and dynamic loading analyses of the two structural models.

#### 3C.1 Hydraulic Model Development

Four hydraulic models are developed for use in the structural analyses of the RCS and the RPV internals:

- RCS four loop hydraulic model.
- SG secondary side hydraulic model.
- RPV isolated hydraulic model.
- Asymmetric Cavity Pressure (ACP) model.

The RCS four loop hydraulic model, the SG secondary side hydraulic model, and the RPV isolated hydraulic model are created using the hydraulics analysis code CRAFT2 (see Section 3C.6). The ACP model is created using the hydraulics analysis code COMPAR2 (see Section 3C.6).

##### 3C.1.1 Reactor Coolant System Four Loop Hydraulic Model

The CRAFT2 model of the RCS primary side consists of a series of control volumes and flow paths which represent the hydraulic features of the RCS.

The RCS primary side hydraulic volume, excluding the surge line and pressurizer volumes, is subdivided into control volumes based on drawings of the components and piping. The piping volume is represented by sequential control volumes that are laid out along the axis of the pipe and the RPV and SG volumes are represented by parallel sequences of control volumes which represent the physical volumes in the various flow paths that exist inside these components. The SG model is based on zero percent tube plugging. The RCP volume is represented by sequential control volumes that are laid out along the axis of the pump. Figure 3C-1—RCS Primary Side Hydraulic Model depicts the RCS four loop hydraulic model.

Control volumes communicate with adjacent control volumes via flow paths. These flow paths are assigned lengths equivalent to the physical flow distance, friction factors to approximate the effect of friction between the fluid and the structure (pipe

or component), and form loss factors (entrance and exit losses) to approximate the effect of sudden contractions and expansions that may exist between the control volumes. The unrecoverable losses (friction and form losses) in each flow path are back calculated from the initial steady state pressure drops, which are obtained from an analysis performed to evaluate Chapter 15 events. Recoverable losses (momentum and elevation losses) are calculated by CRAFT2 as part of the transient solution.

Special flow paths (leak paths) are defined from the RCS to the control volume representing the containment free volume at those locations where the primary side breaks are postulated to occur. Lengths and unrecoverable losses are not defined for leak paths, but break opening times and discharge coefficients are. The break opening area versus time relationships are determined as follows:

- The plastic moment is calculated:

$$\begin{aligned}
 M_p &= SF \left( \frac{I}{c} \right) S_Y \\
 &= \left[ \frac{16R_o(R_o^3 - R_i^3)}{3\pi(R_o^4 - R_i^4)} \right] \left[ \frac{\pi/4(R_o^4 - R_i^4)}{R_o} \right] S_Y \\
 M_p &= \frac{4}{3}(R_o^3 - R_i^3)S_Y \quad (\text{Eqn 3C-1})
 \end{aligned}$$

(Eqtn 3C-1)

where:

SF = Shape Factor for a hollow cylinder

$$= \frac{16R_o(R_o^3 - R_i^3)}{3\pi(R_o^4 - R_i^4)} \quad (\text{Eqtn 3C-12})$$

I = moment of inertia

c = distance to outermost fiber

S<sub>Y</sub> = yield strength

R<sub>o</sub> = outside radius

R<sub>i</sub> = inside radius

- The plastic length of the pipe is calculated assuming that the thrust force caused by a full circumferential guillotine break at the pipe-to-nozzle weld is applied perpendicular to the pipe axis at the break location:

$$M_p = (\text{force})(\text{distance}) = C_D P A_F L_p$$

$$L_p = \frac{M_p}{C_D P A_F} \quad (\text{Eqtn 3C-2})$$

where:

$L_p$  = plastic length of pipe

$C_D$  = hydraulic discharge coefficient

$P$  = pressure in pipe prior to break

$A_F$  = pipe fluid area

- The mass of the plastic length of pipe is calculated:

$$M = (\text{length})(\text{area})(\text{density}) = \frac{L_p (A_M \rho_M + A_F \rho_F)}{g_c} \quad (\text{Eqtn 3C-3})$$

where:

$A_M$  = area of the pipe metal

$\rho_M$  = density of the pipe metal

$\rho_F$  = density of the fluid

$g_c$  = gravitational constant

- The force balance between the thrust force and the accelerated mass is used to derive the acceleration of the pipe and fluid:

$$M a = C_D P A_F$$

$$a = \frac{C_D P A_F}{M} \quad (\text{Eqtn 3C-4})$$

where:

$a$  = acceleration of the pipe and fluid

- The distance of separation (along the axis of the pipe) between the two ends of the pipe at the break that is considered sufficient for a full guillotine break is given by:

$$\begin{aligned}
 d_f &= \frac{2 A_F}{C} \\
 &= \frac{2 \pi R_i^2}{2 \pi R_i} \\
 d_f &= R_i \quad (\text{Eqtn 3C-5})
 \end{aligned}$$

where:

$d$  = separation distance along the axis of the pipe

$C$  = inner circumference of the pipe

- The time to full break opening is determined from the parabolic equation of motion:

$$\begin{aligned}
 d_f &= 1/2 a t_f^2 \\
 t_f &= \sqrt{\frac{2d_f}{a}} \quad (\text{Eqtn 3C-6})
 \end{aligned}$$

where:

$t_f$  = time of full break opening

- Ten time steps between the initiation of the break (time zero) to the time of full break opening ( $t_f$ ) are defined and the parabolic equation is used to determine the time varying pipe end separation distances:

$$d(t) = 1/2 a t^2 \quad (\text{Eqtn 3C-7})$$

where:

$d(t)$  = pipe end separation at time  $t$

- The break opening areas for each of the time steps is calculated as:

$$A(t) = \frac{d(t)}{d_f} A_F \quad (\text{Eqtn 3C-8})$$

where:

$A(t)$  = break opening area at time  $t$

In addition to the inputs described above, heat transfer into the system from the core and heat transfer out of the system at the SG, as well as the RCP hydraulic characteristics, are represented in the model. Given that the depressurization that

occurs after a pipe break event is extremely rapid (depressurization occurs in much less than 0.5 seconds), heat transfer effects and pump characteristics have relatively little influence on the calculation of the resulting hydraulic forcing functions which occur during the depressurization. Therefore, generic data for core heat input parameters, SG heat transfer coefficients and pump parameters are used in this analysis.

The initial conditions for the RCS (pressures, enthalpies and flow) are determined from data taken from an analysis performed to support the evaluation of Chapter 15 events. The RCS average temperature at 100 percent power is reduced by 15°F in the pipe break analyses to account for uncertainties and to address end-of-cycle coastdown conditions.

### **3C.1.2 Steam Generator Secondary Side Hydraulic Model**

The CRAFT2 model of the SG secondary side consists of a series of control volumes and flow paths which represent the hydraulic features of the SG.

The SG secondary side hydraulic volume is subdivided into control volumes based on drawings of the SG. The secondary side volume is represented by parallel sequences of control volumes which represent the physical volumes in the various flow paths that exist inside the SG. The SG model is based on un-fouled tubes and zero percent tube plugging. Figure 3C-2—SG Secondary Side Hydraulic Model depicts the SG secondary side hydraulic model.

Control volumes communicate with adjacent control volumes via flow paths. These flow paths are assigned lengths equivalent to the physical flow distance, friction factors to approximate the effect of friction between the fluid and the structure (SG shell or internals), and form loss factors (entrance and exit losses) to approximate the effect of sudden contractions and expansions that may exist between the control volumes. The unrecoverable losses (friction and form losses) are hand calculated for those flow paths which have a non-zero pressure drop based on hydraulic information obtained from an analysis performed to evaluate SG thermal performance at 100 percent power steady state conditions. The unrecoverable losses for those flow paths where the steady state pressure drop is unknown (e.g. those flow paths which do not exist in the hydraulic model used to evaluate SG thermal performance) are calculated by CRAFT2 as part of the transient solution. The recoverable losses (elevation and momentum losses) for all flow paths are calculated by CRAFT2 as part of the transient solution.

Special flow paths (leak paths) are defined from the SG secondary side to the control volume representing the containment free volume at those locations where the secondary side breaks are postulated to occur. Lengths and unrecoverable losses are not defined for leak paths, but break opening times and discharge coefficients are. The break opening area versus time relationships are determined as indicated in

### Section 3C.1.1.

In addition to the inputs described above, heat transfer into the secondary side from the primary side during steady state conditions is represented in the model. The heat into the system is calculated as the product of the enthalpy and flow rate in the tube bundle flow paths as obtained from the steady state thermal performance analysis of the SG.

The initial conditions for the SG secondary side (pressures, enthalpies, flow, and steam quality) are determined from data taken from an analysis performed to evaluate the SG thermal performance.

### 3C.1.3 Reactor Pressure Vessel Isolated Hydraulic Model

The CRAFT2 model of the RPV consists of a series of control volumes and flow paths which represent the hydraulic features of the RPV.

Loads on the RPV internals due to system internal pressure waves that occur after postulated primary side breaks are determined through hydraulics analysis of the RCS primary side using the hydraulic analysis code, CRAFT2. The CRAFT2 model used is the same model used for the hydraulics analysis of the primary side of the RCS (see Section 3C.1.1), except that additional control volumes and flow paths are added to the representation of the RPV internals. This refinement of the model is necessary to obtain accurate differential pressures across key structural components within the RPV internals, such as the upper and lower core plates and the upper internals support structure. Accordingly, the number of control volumes, and related flow paths, in the RPV downcomer, heavy reflector and active core regions of the RPV internals model are increased beyond the number considered in the RCS four loop hydraulic model described in Section 3C.1.1. Figure 3C-3—RPV Isolated Hydraulic Model depicts the RPV isolated hydraulic model.

Recoverable pressure losses through the various RPV flow paths that are added as part of model refinement are calculated by spreadsheet based on geometry obtained from RPV internals and core support structure drawings and on pressures and temperatures obtained from steady state analysis of the RCS four loop hydraulics model.

Unrecoverable pressure losses are taken directly from steady state hydraulics analysis of the core that is performed in support of core design and from steady state hydraulics analysis of the RPV internal flow paths to assess bypass flows and pressure drops inside the RPV. The spreadsheets are used to perform calculations to determine steady-state pressures, temperatures, and flow rates in the RCS. This data is used to initialize the CRAFT2 thermal-hydraulic model, which is used for RCS loop pipe rupture loading analyses.

The leak paths in the RPV isolated hydraulic model are the same as those representing the primary side pipe breaks in the RCS four loop hydraulic model. The break opening

time for these leak paths is defined in the same manner as it was for the leak paths in the RCS four loop hydraulic model (see Equations 3C-1 through 3C-8).

In addition to the modeling refinement applied to the RPV internals described above, the reactor core and RCP parameters used in the RCS four loop hydraulic model are adjusted for use in the RPV isolated hydraulic model. The core parameters (heat transfer area and heat flux) used in the RCS four loop hydraulic model are replaced by parameters based on plant specific data and the RCP head is also adjusted to a plant specific value from the value used in the RCS four loop hydraulic model.

The initial conditions for the RCS (pressures, enthalpies and flow) are taken from the steady state analysis of the RCS four loop hydraulic model, except for the flows through the various flow paths inside the RPV. The initial conditions (pressures, enthalpies and flow) for the RPV internals are calculated by spreadsheet using data obtained from an analysis of the RPV internal flow paths to assess bypass flows and pressure drops inside the RPV.

### **3C.1.4 Asymmetric Cavity Pressure Hydraulic Model**

The COMPAR2 model used consists of a series of control volumes and flow paths which represent the cavity volumes around the SG and RCP.

The cavity volumes are subdivided into control volumes, based on drawings of the reactor building and the RCS components, vertically along the height of the cavity and circumferentially around the components in the horizontal plane. The control volumes are smaller in the vicinity of the breaks, as shown in Figure 3C-4—ACP Hydraulic Model. Volumes of large components and piping that reside in the control volumes are subtracted out and the resulting volume is further reduced by a factor of 0.9 to account for the presence of small piping, platforms, cable trays, and other solids in the control volumes.

Control volumes communicate with adjacent control volumes via flow paths. These flow paths are assigned lengths equivalent to the distance between the centroids of the control volumes which they connect and are also assigned resistance coefficients (entrance and exit losses) to approximate the effect of sudden contractions and expansions that may exist between the control volumes. Friction losses are negligible relative to these form losses and so are not included in the analysis.

### **3C.2 Structural Model Development**

Two structural models are developed for use in the structural analysis of the RCS and RPV internals:

- RCS four loop structural model

- RPV isolated structural model

The RCS four loop structural model and the RPV isolated structural model are created using the structural analysis code BWSPAN (see Section 3C.6).

### 3C.2.1 Reactor Coolant System Four Loop Structural Model

The RCS four loop structural model consists of representations of the:

- RCS components.
  - RPV (Section 3C.2.1.1)
  - SGs and SG internals (Section 3C.2.1.2)
  - RCPs and the RCP internals (Section 3C.2.1.3)
  - Pressurizer (PZR) (Section 3C.2.1.4)
- RCS component supports (described in the component sections).
- RCS piping (Section 3C.2.1.5).
  - Main Coolant Loop (MCL)
  - Surge Line (SL)
- Reactor Building Internal Structures (RBIS) (Section 3C.2.1.6).

Beam elements represent the RCS components, linear support elements (i.e., component support columns and SG upper lateral support struts), RPV vertical supports, PZR supports, piping, and RBIS sections. Springs represent the snubbers on the SGs, the snubbers on the RCPs, the SG lower lateral support bumpers, and the RPV horizontal supports. Excluding the surge line, piping attached to the MCL is not included in the model because it meets the decoupling criteria described in Appendix 3F. Loops 1, 2, and 4 of the model contain simplified representations of the RCP and SG (and their internals) and Loop 3 contains detailed representations of the RCP and SG (and their internals).

In addition to the mass of the model elements described above, the mass of the RPV closure head appurtenances (i.e., control rod drive mechanisms (CRDMs) and closure head equipment (CHE)) and the RPV internals are included in the RCS four loop structural model. The entrained fluid and thermal insulation mass for the components and piping is also accounted for in the model.

The RCS four loop structural model is developed using nominal dimensions.



Including the RBIS in this model allows explicit consideration of how the RBIS affects the RCS response to static and dynamic loading, and allows application of the safe shutdown earthquake (SSE) excitations at a single point (i.e. the basemat) in the model.

Because of the gaps at the SG lower lateral support bumpers during operating conditions, the RCS four loop structural model is geometrically non-linear. This non-linearity is accounted for in the dynamic analyses of the model as described in Section 3C.4.2.

This model provides the RCS response, i.e., displacements, loads and accelerations (for dynamic loading only), to static and dynamic loading at any RCS location, excluding RPV internals locations. The response of the RPV internals to static and dynamic loading is obtained from the RPV isolated structural model described in Section 3C.2.2. Detailed representations of the RPV internals and RPV closure head appurtenances are included in the RPV isolated structural model.

Figure 3C-5—RCS Four-Loop Structural Model depicts the RCS four loop structural model.

#### **3C.2.1.1 Reactor Pressure Vessel Model**

In the RPV model, beam elements represent the RPV. These elements are assigned distributed mass reflecting the weight of the pressure boundary, entrained fluid, and thermal insulation, and are assigned cross-sectional properties representative of the RPV pressure boundary. The RPV internals and fuel mass are lumped at the appropriate center of gravity locations. The mass of the CRDMs and RPV CHE is lumped at the top of the upper head. Local flexibility of the RPV shell at the primary nozzle connections is accounted for in the model.

The RPV model is connected to the RBIS through representations of the RPV support ring, which provides support to the RPV primary nozzles. The support ring is represented by vertical beam elements under each primary nozzle and horizontal springs perpendicular to each primary nozzle centerline. The stiffness of the concrete beneath the RPV support ring is also accounted for in the model.

Figure 3C-5 depicts the simplified RPV model used in the RCS four loop structural model.

#### **3C.2.1.2 Steam Generator Model**

The SG lower internals (i.e., tubesheet, tubes, tube support plates, anti-vibration bars, bundle wrappers, and seismic stops) are represented by beam elements and springs in the Loop 3 SG model, as necessary to generate loads needed for stress analysis of the internals. The mass of the primary and secondary side entrained fluid is distributed along the elements representing the tubes and the bundle wrappers. Beam elements

represent the SG pressure boundary. These elements are assigned distributed mass reflecting the weight of the pressure boundary and thermal insulation and are given cross-sectional properties representative of the SG pressure boundary. The mass of the upper internals (i.e., feedwater headers, platforms, separators, dryers, and supports), tube support plates (TSPs), and anti-vibration bars (AVBs) are lumped at appropriate nodes in the model. The portion of the upper lateral support snubber and strut mass supported by the SG is lumped on the SG pressure boundary node at the upper lateral support elevation. Local flexibility of the SG shell at the primary nozzle connections is accounted for in the model.

Beam elements represent the SGs in Loops 1, 2, and 4. These elements are assigned distributed mass reflecting weight of the pressure boundary, internals, entrained fluid, and thermal insulation and are given cross-sectional properties representative of the SG pressure boundary. The portion of the upper lateral support snubber and strut mass that is supported by the SG is lumped at the upper lateral support elevation. Local flexibility of the SG shell at the primary nozzle connections is accounted for in the model.

The SG models in the four loops are connected to the RBIS through representations of the SG vertical columns, lower lateral support bumpers, upper lateral support snubbers, and upper lateral support struts. Beam elements represent the vertical columns and upper lateral support struts, while springs represent the lower lateral support bumpers and upper lateral support snubbers. The stiffness of the concrete at the locations where the vertical columns, lower lateral support bumpers, upper lateral support snubbers, and upper lateral support struts connect to the RBIS is also accounted for in the model.

Figure 3C-5 depicts the simplified SG model used in Loops 1, 2, and 4 of the RCS four loop structural model and Figure 3C-6—SG Detailed Structural Model depicts the detailed SG model used in Loop 3 of the RCS four loop structural model.

### **3C.2.1.3 Reactor Coolant Pump Model**

The RCP internals (i.e., shaft, impeller, bearings, seal packages), RCP motor (i.e., rotor, stator/casing, oil cooler), and RCP motor stand are represented by beam elements and springs in the RCS Loop 3 RCP model, as necessary, to generate loads needed for stress analysis of the internals and motor. Beam elements represent the RCP pressure boundary. These elements are assigned lumped masses reflecting the weight of the RCP pressure boundary, entrained fluid, and thermal insulation, and are assigned cross-sectional properties representative of the RCP pressure boundary. The portion of the lateral support snubber mass supported by the RCP is lumped on the RCP pressure boundary node at the lateral support elevation. Local flexibility of the RCP shell at the primary nozzle connections is accounted for in the model.

Beam elements represent the RCPs in Loops 1, 2, and 4. These elements are assigned distributed mass reflecting the weight of the pressure boundary, internals, entrained fluid, and thermal insulation. Beam elements represent the motor stands in Loops 1, 2, and 4. These elements are assigned distributed mass consistent with the motor stand weight. Beam elements represent the motors in Loops 1, 2, and 4. These elements are assigned distributed mass reflecting the weight of the casing, internals and oil cooler. The beam elements are given cross-sectional properties representative of the RCP pressure boundary, motor stand, and motor, as appropriate.

The RCP models in the four loops are connected to the RBIS through representations of the RCP vertical columns and the lateral support snubbers. Beam elements represent the vertical columns, and springs represent the snubbers. The stiffness of the concrete at the locations where the vertical columns and lateral support snubbers connect to the RBIS is also accounted for in the model.

Figure 3C-5 depicts the simplified RCP/motor stand/motor model used in Loops 1, 2, and 4 of the RCS four loop structural model and Figure 3C-7—RCP Detailed Structural Model depicts the detailed RCP, motor stand, and motor model used in Loop 3 of the RCS four loop structural model.

#### **3C.2.1.4 Pressurizer Model**

The PZR pressure boundary is represented by beam elements. These elements are assigned distributed mass reflecting the weight of the pressure boundary, entrained fluid, and thermal insulation and are given cross-sectional properties representative of the PZR pressure boundary. Beam elements also represent the heaters and are assigned distributed mass consistent with the weight of the heaters. The heater couplings, support lugs and the safety valves are represented by lumped mass at the appropriate elevations. Local flexibility of the PZR shell at the support lug and lateral bumper connections is accounted for in the model.

The PZR model is connected to the RBIS through representations of the PZR support lugs, and PZR bumpers. Beam elements represent the support lugs and bumpers. The stiffness of the concrete at the locations where the support lugs and bumpers connect to the RBIS is also accounted for in the model.

Figure 3C-5 depicts the PZR model used in the RCS four loop structural model.

#### **3C.2.1.5 Reactor Coolant System Piping Model**

The MCL and SL piping is represented by beam elements that connect the primary components. These elements are assigned distributed mass reflecting the weight of the pressure boundary, entrained fluid, and thermal insulation and are assigned cross-sectional properties representative of the pipe pressure boundary.

The SL has two constant force spring hangers that are represented by vertical forces in the deadweight analysis. The MCL piping does not have any supports other than the primary components.

Figure 3C-5 depicts the MCL and SL piping model used in the RCS four loop structural model.

### **3C.2.1.6 Reactor Building Internal Structures Model**

The RBIS “stick” model that is coupled with the RCS model in the RCS four loop structural model was originally created for building analysis purposes and is tuned to match the frequencies of a three-dimensional finite element model of the RBIS. Refer to Section 3.7.2 for a description of this process. The original RBIS stick model input was converted to the input format of the RCS structural analysis code being used (BWSPAN, see Section 3C.6).

In the RCS four loop structural model, beam elements represent the RBIS. These elements are assigned lumped mass and cross-sectional properties reflecting the mass, stiffness, and frequency characteristics of the RBIS. Separate elements represent the shear stiffness and the bending stiffness. Lumped masses are located eccentrically to represent the mass distribution of the physical structure accurately. Rigid members connect the RBIS model to the building end of the RCS component supports.

### **3C.2.2 Reactor Pressure Vessel Isolated Structural Model**

The RPV isolated structural model consists of representations of the RPV pressure boundary, CRDMs, CRDM nozzles, CHE, lower internals, upper internals, and fuel assemblies. Beam elements represent the pressure boundary; beam elements and springs represent the internals and fuel assemblies to simulate the physical arrangement. A single beam element represents the CRDMs and CRDM nozzles; beam elements represent the CHE linear support elements (i.e., columns, cross braces, beams). The mass of the RPV entrained fluid and thermal insulation is also accounted for in the model.

The SGs, RCPs, PZR, the component supports, the interconnecting piping (i.e., MCL and SL) and the RBIS are also included in the RPV isolated structural model. The models for the components, piping, and RBIS are the same as those described in Section 3C.2.1 (the simplified representations of the SGs and RCPs are used in all four loops of the RPV isolated structural model). The models for the RCS component supports are also included in this model and are the same as those described in Section 3C.2.1. Excluding the surge line, piping attached to the primary loop is not included in the model because it meets the decoupling criteria described in Section 3F.5.4.2.

The RPV isolated structural model is developed using nominal dimensions.

Hydrodynamic coupling of the RPV shell to the core barrel (CB) shell and of the CB to the heavy reflector (HR) is simulated in the RPV isolated structural model through the following methodology:

- Separate finite element models of the RPV CB and HR structures are created using CASS (see Section 3C.6) and the in-air beam mode frequencies are determined for each model;
- Separate finite element models of the annular fluid between the RPV shell and the CB, and between the CB and HR, with rigid boundary conditions at the structural surfaces, are created in CASS and the natural frequencies of these fluid cylinders are determined;
- The first bending modes of the two structural models and the modes of the fluid models are coupled in EBDynamics (see Section 3C.6), which uses the equations presented in, “Fluid-Structure Dynamics with a Modal Hybrid Method,” Journal of Pressure Vessel Technology, Vol. 114 (Reference 2), and the frequencies of the coupled fluid-structure models are determined;
- A “virtual mass” matrix, representing the mass necessary to reduce the CB and HR bending frequencies obtained from the in-air values down to the values obtained from the coupled fluid-structure models, is determined;
- The virtual mass matrix is included in the model of the RPV internals to capture the hydrodynamic mass coupling effects between the RPV shell, CB and HR.

Including the RBIS in this model allows explicit consideration of how the RBIS affects the RPV response to static and dynamic loading, and allows application of the SSE excitations at a single point (i.e. the basemat) in the model.

Because of the gaps between the various components of the RPV internals and at the SG bumpers during operating conditions, the RPV isolated structural model is geometrically non-linear. This non-linearity is accounted for in the dynamic analyses of the model as described in Section 3C.4.2.

This model provides the RPV response (i.e. displacements, loads and accelerations (dynamic loading only)) to applied static and dynamic loading at any RPV location, including appurtenances and internals.

Figure 3C-8—RPV Isolated Structural Model depicts the RPV isolated structural model.

### 3C.3 Hydraulic Loading Analyses

Hydraulic forcing functions that result from a high energy line break (HELB) event include thrust loads at the break, jet impingement from the break, system internal pressure waves, and asymmetric cavity pressure waves. The system internal pressure loading and asymmetric cavity pressure loading analyses show that the strong dynamic

excitation of the postulated primary and secondary side pipe breaks is dissipated in less than 0.5 seconds. Accordingly, the postulated pipe break events are simulated up to 0.5 seconds after the break.

### 3C.3.1 Thrust Loading

The thrust loads at the break locations are calculated using the thrust force equation from Appendix B of ANSI/ANS-58.2-1988, "Design Basis for Protection of Light Water Nuclear Power Plants Against the Effects of Postulated Pipe Rupture" (Reference 3):

$$T_{SS} = C_T P_O A_e \text{ (Eqtn 3C-9)}$$

where:

$T_{SS}$  = steady state thrust force

$C_T$  = steady state thrust coefficient

$P_O$  = initial pressure in the source

$A_e$  = break plane area

The calculated thrust forces are applied to Loop 3 of the RCS four loop structural model at the location of the postulated primary side breaks at the low head safety injection (LHSI) and medium head safety injection (MHSI) nozzles and at the location of the MFW nozzle breaks. The forces are applied as constant force time histories that rise from zero to the steady state thrust force in 0.001 seconds, where they remain until the end of the event at 0.5 seconds. The thrust force due to a break in the MS line outside of the reactor building does not load the SG because of the supports and anchors on the line between the break and the SG.

### 3C.3.2 Jet Impingement Loading

When assessing potential for jet impingement, the geometry of the attached line is evaluated against the geometry of the RCS to determine if a jet plume could impact an RCS component:

- The jet from a postulated break at the LHSI nozzle on the hot leg (HL) does not impinge any of the RCS components. The nozzle, which is located midway between the RPV and the SG, points directly down toward the floor.
- The jet from a postulated break in the MHSI nozzle on the cold leg (CL) does not impinge any of the RCS components. The nozzle, which is located midway between the RCP and the RPV, is inclined from the axis of the CL by 45 degrees in the horizontal plane of the CL. It points away from the RPV and towards the wall that separates the SG and RCP cavities.

- The jet from a postulated break in the MFW nozzle on the SG can impinge the SG.
- The jet from a postulated break in the MS line outside of the reactor building cannot impinge any of the RCS components.

Therefore, only the MFW nozzle break is evaluated for jet impingement loading.

Given the close proximity of the MFW nozzle break plane to the SG shell, the full area of the jet in its entirety impinges the SG shell. The force of the jet applied to the SG is calculated according to Equation D-2 and Equation D-5 given in Appendix D of Reference 3:

$$F_j = K_\phi C_T P_O A_e = K_\phi T_{SS} \quad (\text{Eqtn 3C-10})$$

where:

$K_\phi$  = shape factor

$T_{SS}$  = as defined in Equation 3C-9 above

The calculated jet impingement force is applied to the Loop 3 SG at the location of the postulated MFW nozzle break. The force is applied as a constant force time history that rises from zero to the steady state value in 0.001 seconds, where it remains until the end of the event at 0.5 seconds.

### 3C.3.3 System Internal Pressure Waves

Separate hydraulics analyses are performed to generate system internal pressure wave loading of the RCS primary side, the SG secondary side and the RPV internals.

These hydraulics analyses are performed using the hydraulic analysis code, CRAFT2 (see Section 3C.6). CRAFT2 solves the control volume thermodynamics and flow path momentum equations assuming a homogenous mixture and thermodynamic equilibrium. The thermodynamic state point at any time in the blowdown transient is determined from a state equation with the values of specific internal energy and specific volume calculated from conservation of energy and conservation of mass principles. The rate of mass transfer from one control volume to another is calculated from a derivation of the one-dimensional conservation of momentum equation. Inertia, recoverable head (elevation and dynamic heads), and the unrecoverable losses (friction and form losses) are all considered when calculating the mass transfer from one control volume to another. Additional information regarding the solution techniques used by CRAFT2 can be found in Topical Report BAW-10132, "Analytical Methods Description, Reactor Coolant System Hydrodynamic Loadings During a Loss-of-Coolant Accident" (Reference 4).

### **3C.3.3.1 Reactor Coolant System Primary Side Internal Pressure Waves**

Loads on the RCS due to primary side internal pressure waves are generated using the CRAFT2 hydraulic model described in Section 3C.1.1.

CRAFT2 outputs force time histories that act on the RCS piping and components during steady state conditions and after a pipe break event. These time histories act at locations in the model where fluid flow area or fluid flow direction change, and are calculated through conservation of momentum considerations. They are oriented for application to the RCS four loop structural model through use of the post-processing program, BWHIST (see Section 3C.6). The resulting time histories are applied to the RCS four loop structural model in the HELB analysis.

CRAFT2 also outputs time histories that define the mass and energy releases into the containment building which occur after the postulated pipe break event. These time histories serve as input to the asymmetric cavity pressure analysis of the containment hydraulic model (see Section 3C.3.4).

### **3C.3.3.2 Steam Generator Secondary Side Internal Pressure Waves**

Loads on the SG due to secondary side internal pressure waves are generated using the CRAFT2 hydraulic model described in Section 3C.1.2.

CRAFT2 outputs pressure time histories that act on the SG internals during steady state conditions and after a pipe break event. These pressure time histories act at locations in the model where fluid flow area or fluid flow direction change, and are calculated through conservation of momentum considerations. The pressure time histories are converted to force time histories (by multiplying the pressures by the appropriate surface area) and they are oriented for application to the RCS four loop structural model through use of the post-processing program, BWHIST (see Section 3C.6). The resulting force time histories are applied to the RCS four loop structural model in the HELB analysis.

CRAFT2 also outputs time histories that define the mass and energy releases into the containment building that occur after the postulated MFW line break. These time histories serve as input to the asymmetric cavity pressure analysis of the containment hydraulic model (see Section 3C.3.4). Since the break in the MS line is outside of the reactor building, the mass and energy released do not generate asymmetric cavity pressure loading of the RCS.

### **3C.3.3.3 Reactor Pressure Vessel Internal Pressure Waves**

Loads on the RPV internals, core support structures and core due to primary side internal pressure waves are generated using the CRAFT2 hydraulic model described in Section 3C.1.3.



CRAFT2 outputs pressure time histories that act on the RPV internals, core support structures and core during steady state conditions and after a pipe break event. These pressure time histories act at locations in the model where fluid flow area or fluid flow direction change, and are calculated through conservation of momentum considerations. The pressure time histories are converted to force time histories (by multiplying the pressures by the appropriate surface area) and they are oriented for application to the RPV isolated structural model through use of the post-processing program, BWHIST (see Section 3C.6). The resulting force time histories are applied to the RPV isolated structural model in the HELB analysis.

### 3C.3.4 Asymmetric Cavity Pressure Wave Loading

Asymmetric cavity pressure (ACP) loading of the SG and RCP due to the primary side and MFW nozzle breaks is calculated using the hydraulic analysis code, COMPAR2 (see Section 3C.6).

COMPAR2 solves the control volume thermodynamics and flow path momentum equations assuming a homogenous mixture and thermodynamic equilibrium. The effects of inertia are included and formulations for water, steam, air, and for mixtures of these three fluids are considered. The thermodynamic state point and flow path calculations are separated by means of a quasi-static method of analysis where one is assumed constant while the other is calculated and vice-versa. At a given time  $t_i$ :

- Volume mass and energy accounting is made on the basis of:
  - Mass and energy addition (from pipe break) that occurs from time  $t_{i-1}$  to time  $t_i$ ;
  - Flow path mass and energy flows to or from each control volume using the values calculated at time,  $t_{i-1}$  and assumed to be constant from time  $t_{i-1}$  to time  $t_i$ . The conservation of momentum equations used to calculate these flows is based on the assumptions of one-dimensional flow, constant density, constant flow path area and negligible effects due to change in elevation.
- Control volume thermodynamic state points are then determined for time  $t_i$ .
- The time  $t_i$  state points are assumed to be constant and are used to calculate the new flow path mass and energy flows.

This approach allows the transient response to be calculated in an explicit manner without iteration or implicit matrix solution techniques.

To verify that the control volume sizes in the ACP hydraulic model are sufficiently small to provide a converged solution, a mesh size study is performed by varying the size of the control volumes in the vicinity of the MFW nozzle break. Comparison of the pressures in several control volumes at various locations around and along the

height of the SG and at the RCP as obtained from the models used in the study demonstrate that the model used to produce the ACP loads on the RCS is sufficiently discretized to provide a converged solution.

The rates of mass and energy release from the postulated break are obtained from the hydraulic analysis of the RCS primary side, in the case of the primary side breaks, and from the hydraulic analysis of the SG secondary side, in the case of the MFW nozzle break. The postulated MS line break is outside of the reactor building and therefore does not create ACP loading of the RCS. The mass and energy release time histories are applied to the control volumes which border the break location in the COMPAR2 model.

The pressure time histories in the control volumes bordering the SG and RCP that result from application of mass and energy releases from the primary side and MFW nozzle breaks are obtained from the COMPAR2 output. These pressure time histories are converted to force time histories (by multiplying the pressures times the appropriate component surface area) and they are oriented for application to the RCS four loop structural model through use of the post-processing program, BWHIST (see Section 3C.6).

### **3C.4 Structural Loading Analysis**

The RCS four loop structural model and the RPV isolated structural model are subject to the applied static and dynamic loadings listed below:

- Static
  - Deadweight
  - Internal pressure
  - Steady state flow
  - Thermal effects
- Dynamic
  - HELB
  - SSE

The loading analyses for the structural models are performed with the structural analysis code BWSPAN (see Section 3C.6). Stress and fatigue analysis of the RCS components and piping and the stress analysis of the supports using the loads from these analyses are described in Section 3.9.3.

### **3C.4.1 Static Loading**

#### **3C.4.1.1 Deadweight**

The mass of the modeled components and their internals, entrained fluid, and thermal insulation are considered as distributed mass in the deadweight analysis. The CRDM mass and control rod drive support structure mass (i.e. the CHE mass) are considered as lumped masses in the RCS four loop structural model and as distributed mass in the RPV isolated structural model. The RCP motor mass is considered as lumped mass in both models. Component support masses (e.g., structural steel beams, snubbers, struts) are considered as distributed or lumped masses, as appropriate.

Deadweight load case analysis is accomplished through the application of a 1g downward acceleration to the model.

#### **3C.4.1.2 Internal Pressure**

The RCS design pressure, 2535 psig, is used in the stress analysis of the RCS components and piping for design conditions. Maximum service pressures for Service Level A, B, C, and D Conditions and for Test Conditions are used in the primary stress analyses of the RCS components and piping.

Transient pressures for the Service Level A and B Conditions will be used in the secondary stress and fatigue analyses of the RCS components and piping. Section 3.9.1 provides a list of the Service Level A and B transients to be considered in the secondary stress and fatigue analyses.

#### **3C.4.1.3 Steady State Flow**

Under 100 percent power steady flow conditions the RCS components and piping are subjected to flow load at locations where flow direction or flow area change. These loads are considered in the stress analyses of the RCS components, piping and supports.

#### **3C.4.1.4 Thermal Effects**

The RCS structural model is analyzed for thermal expansion at 100 percent power operating conditions. Components, component internals, piping, and support temperatures are considered. Analysis of thermal expansion is accomplished through consideration of the appropriate coefficient of thermal expansion, the model element length, and the change in temperature from the temperature datum of 70°F.

The RPV internals will be analyzed for 100 percent power thermal expansion in the same manner.

Transient temperatures for the Service Level A and B Conditions will be used in the secondary stress and fatigue analyses of the RCS components and piping. Thermal

effects considered include thermal expansion, through-wall thermal gradients and stress due to material discontinuity. Section 3.9.1 provides a list of the Service Level A and B transients to be considered in the secondary stress and fatigue analyses.

### **3C.4.2 Dynamic Loading**

#### **3C.4.2.1 High Energy Line Break Analysis**

The RCS four loop structural model and the RPV isolated structural model are analyzed for HELB loading due to postulated full circumferential (guillotine) breaks in lines attached to the primary system. The RCS is also analyzed for HELB loading due to postulated full circumferential breaks in lines attached to the secondary side of the SG. All breaks are considered to occur when the unit is at 100 percent power normal operating conditions.

The bounding primary side pipe breaks are in the 10 inch Schedule 160 LHSI lines and in the 10 inch Schedule 160 MHSI lines at their connections to the HL and CL nozzles. Breaks in the hot, crossover and cold legs and in the surge line are not postulated because these lines meet Leak-Before-Break criteria (see Section 3.6.3). The bounding secondary side breaks are in the 20 inch Schedule 120 main feedwater (MFW) lines at their connections to the steam generators and in the 31.5 inch (outside diameter) main steam (MS) lines outside of the reactor building. Breaks are not postulated in the MS lines inside the reactor building because breaks in these portions of the MS lines are eliminated through application of LBB methodology (see Section 3.6.3). Given the symmetry of the four RCS loops and the symmetry of the reactor building cavities in which the RCS components reside, it is only necessary to postulate breaks in one loop of the RCS. Therefore, breaks are only postulated to occur in Loop 3 of the RCS.

Analysis of the RCS and RPV internals for pipe break loading is accomplished in two steps: 1) Hydraulics analyses of the RCS and RPV to generate forcing functions for application to the appropriate structural model, and 2) Application of the hydraulic forcing functions to the RCS four loop structural model and the RPV isolated structural model to obtain the dynamic response of the RCS and RPV internals.

The RCS four loop structural model and the RPV isolated structural model are analyzed for the hydraulic loadings which result from the postulated primary and secondary side HELB events described above. This is accomplished through the simultaneous application of the hydraulic forcing functions (force time histories) described in Section 3C.3 (thrust, jet impingement, system internal pressure waves, asymmetric cavity pressure waves) to these structural models for each postulated pipe break. As noted in Section 3C.3, all four of these forcing function types are not present for each break considered.

### 3C.4.2.1.1 Reactor Coolant System Four Loop Structural Model High Energy Line Break Analysis

The RCS four loop structural model is analyzed for the effects of the bounding primary and secondary side postulated breaks through application of hydraulic forcing functions representing the various constituents of a HELB event:

- Thrust loads, system internal pressure waves and asymmetric cavity pressure waves due to a break at the 10 inch Schedule 160 LHSI line connection to the HL nozzle;
- Thrust loads, system internal pressure waves and asymmetric cavity pressure waves due to a break at the 10 inch Schedule 160 MHSI line connection to the CL nozzle;
- Thrust loads, jet impingement loads, system internal pressure wave loads and asymmetric cavity pressure wave loads due to a break at the 20 inch Schedule 120 MFW line connection to the SG nozzle; and
- System internal pressure wave loads due to a break in the 31.5 inch (outside diameter) MS line outside of the reactor building.

The RCS response to the simultaneously applied forcing functions is calculated using the Wilson-  $\theta$  method of direct step-by-step implicit integration. This method is unconditionally stable when the time increment constant,  $\theta$ , is at least 1.37. See Section 8.2.3 of Numerical Methods in Finite Element Analysis by Bathe and Wilson (Reference 5). BWSPAN, the structural analysis code used to perform the pipe break analyses, uses  $\theta = 1.4$ . Use of the direct step-by-step integration solution method allows the 0.0625 inch gaps that exist at the SG lower lateral support bumpers during 100 percent power normal operating conditions to be considered in the analysis.

Proportional Rayleigh damping (mass and stiffness weighted damping) is applied to the system with the Rayleigh mass constant ( $\alpha$ ) set to 0.9 and the Rayleigh stiffness constant ( $\beta$ ) set to 0.00045. Figure 3C-9—Rayleigh Damping Curve compares the Rayleigh damping obtained with these constants to modal damping obtained from linear analysis of the RCS using composite damping obtained from Revision 1 of NRC Regulatory Guide (RG) 1.61, “Damping Values for Seismic Design of Nuclear Power Plants,” as shown in Table 3.7.1-1. The Rayleigh curve depicted in Figure 3C-9 is calculated using Equation 11.4.8 in Dynamics of Structures by Chopra (Reference 6):

$$\xi_i = \frac{\alpha}{2} \frac{1}{\omega_i} + \frac{\beta}{2} \omega_i \quad (\text{Eqtn 3C-11})$$

where:

$\alpha$  = Rayleigh damping mass constant

$\beta$  = Rayleigh damping stiffness constant

$\omega_i$  = circular frequency of the  $i$ th mode

$\xi_i$  = critical damping ratio for the  $i$ th mode

The integration time step used in these analyses is 0.00025 seconds.

### 3C.4.2.1.2 Reactor Pressure Vessel Isolated Structural Model High Energy Line Break Analysis

The RPV isolated structural model is analyzed for the effects of the bounding primary side postulated breaks through application of hydraulic forcing functions representing the system internal pressure waves. The bounding primary side breaks are the breaks at the 10 inch Schedule 160 LHSI line connection to the HL nozzle and at the 10 inch Schedule 160 MHSI line connection to the CL nozzle.

The response of the RPV isolated model to the simultaneously applied forcing functions is calculated using the Wilson- $\theta$  method of direct step-by-step implicit integration. This method is unconditionally stable when the time increment constant,  $\theta$ , is at least 1.37 (see Section 8.2.3 of Reference 5). BWSPAN, the structural analysis code used to perform the pipe break analyses, uses  $\theta = 1.4$ . Use of the direct step-by-step integration solution method allows the gaps that exist at the SG lower lateral support bumpers and in the RPV internals during 100 percent power normal operating conditions to be considered in the analysis.

Non-proportional Rayleigh damping (mass and stiffness weighted damping) is applied to the model. The Rayleigh mass and stiffness constants ( $\alpha$  and  $\beta$ ) are determined for major groupings of elements in the model (groups of elements representing the RBIS, RPV, SG, RCP, PZR, RCS piping, supports) using Equation 3C-11, where the critical damping ratios for the various sets of elements are set to the applicable RG 1.61 damping value (see Table 3.7.1-1).

The integration time step used in these analyses is 0.0001 seconds.

### 3C.4.2.2 Seismic Analysis

As described in Section 3.7.1.3, the seismic design basis of the U.S. EPR includes combinations of soil profile and control motions, ranging from soft soil through medium soil to hard rock. The response of the Nuclear Island Common Basemat Structure at the basemat elevation obtained from soil-structure interaction analysis considering these soil cases serves as input to the seismic analyses of the RCS four loop structural model and the RPV isolated model.

### 3C.4.2.2.1 Reactor Coolant System Four Loop Structural Model Seismic Analysis

The Table 3.7.1-6 seismic soil cases included in the seismic design basis are applied as input motions to the RCS four loop structural model.

Basemat translational and rotational excitations (acceleration time histories) in the three global directions are applied to the RCS structural model, at the base of the RBIS, for each of the seismic cases. Application of all the seismic cases in the design basis seismic analysis of the RCS provides some coverage of uncertainties associated with the soil-structure interaction analysis and the model itself because each of the seismic cases tends to exhibit slightly different frequency characteristics, but relatively similar peak acceleration values, across much of the frequency range of interest to the RCS. To enhance this effect and to provide further coverage of uncertainties inherent in the analysis, the sets of seismic excitations are applied to three different configurations of the RCS model: the first model configuration has the modulus of elasticity for the RBIS elements set at 70 percent of the nominal value, the second model configuration has the modulus of elasticity for the RBIS elements set at its nominal value, and the third model configuration has the modulus of elasticity for the RBIS elements set at 130 percent of the nominal value.

The seismic loads for the stress and fatigue analysis of the RCS pressure boundary components are generated from computer analyses through application of these seismic cases to an RCS four loop structural model with the gaps at the SG Lower Lateral Support (LLS) bumpers considered closed. Physically, the SG bumpers are designed to provide a nominal one-sixteenth inch gap at 100 percent normal operating conditions. To determine the effect that this non-linearity has on the seismic response of the RCS, the seismic cases are analyzed using linear and non-linear versions of the RCS four loop structural model with Rayleigh damping and direct step-by-step integration time history analyses. The results of these runs are compared to arrive at factors which are then applied to a linear modal superposition time history solution of the RCS four loop structural model, using modal damping values from Table 3.7.1-1 with effects of missing mass included beyond the cut-off frequency. The cut-off frequency is determined to be 70 Hz for high frequency (HF) cases and 35 Hz for generic cases with missing mass included at higher frequencies for all cases. A step-by-step method for performing the seismic analysis of the RCS four loop structural model is described as follows:

- Basemat excitations for the seismic cases are applied to the three versions of the linear RCS four loop structural model (RBIS modulus of elasticity equal to 70 percent of the nominal value, equal to the nominal value, and equal to 130 percent of the nominal value) and to the three versions of the non-linear RCS four loop structural model.
- The same Rayleigh proportional damping is applied in both the linear and the non-linear analyses. The formula shown in Equation 3C-11 is used to calculate a

Rayleigh damping curve representative of the modal damping values obtained from analyzing the linear RCS four loop structural model for frequencies and mode shapes using composite modal damping, with damping values taken from Table 3.7.1-1.

The Rayleigh damping curve used in the comparative analyses is based on Rayleigh damping coefficients of  $\alpha = 1.7$  and  $\beta = 0.00055$ . The resulting curve is shown in Figure 3C-9, which provides a comparison of the damping curves used for seismic and HELB loading as well as the composite modal damping values.

- The modal superposition time history solution technique, as described in Section 8.3 of Reference 5, is used to calculate the response of the linear RCS four loop structural model. In this scheme, the equations of motion are translated into the principal coordinate system in order to decouple the modes from one another and the individual equations of motion for each mode are solved time-for-time using the Wilson- $\theta$  integration scheme, as described in Section 8.2 of Reference 5. The cut-off frequencies for the seismic cases are 70 Hz for HF cases and 35 Hz for generic cases with missing mass included at higher frequencies for all cases. Modal damping values from Table 3.7.1-1 are used for the linear time history analysis.
- Loads at key locations obtained from the analysis of the linear RCS four loop structural model for a particular seismic case are compared to the corresponding loads from the analysis of the non-linear RCS four loop structural model for the same seismic case. The key locations evaluated are:
  - RPV HL and CL nozzles
  - RPV support pads
  - SG HL and crossover leg nozzles
  - SG tube support plates
  - SG shell at main feedwater elevation
  - SG shell at the top elevation
  - SG vertical column supports
  - SG lower lateral support bumpers
  - SG upper lateral support snubbers
  - SG upper lateral support struts
  - RCP suction and discharge nozzles
  - RCP vertical column supports
  - RCP lateral supports



- PZR surge line nozzle
  - PZR shell at the top elevation
  - PZR lower bracket support
  - PZR lateral bumper
- Based on the comparisons in the previous step, bounding factors are calculated for the primary nozzles (including the HL surge line nozzle), the RCS piping (including the surge line), the individual RCS components, and each of the RCS component supports. Conservatively, none of the factors are taken as less than 1.0 (i.e. in those instances where the non-linear analyses produced lower loads than the linear analysis, the factors are taken as 1.0 rather than less than 1.0).

The response of the RCS is obtained from time history analysis of the linear RCS four loop structural model, considering the basemat excitations from all seismic cases. These time history analyses use modal superposition time history solution techniques with a cut-off frequency determined to be 70 Hz for HF cases and 35 Hz for generic cases with missing mass included at higher frequencies for all cases and modal damping as shown in Table 3.7.1-1.

The integration time step for the seismic time history analyses of the linear RCS model is selected by the analysis code, BWSPAN, as the inverse of 30 times the cutoff period. As an example, for a cut-off frequency of 35 Hz, the time step is determined by,  $1/(30 * 35) = 0.00095$  seconds. Several authors recommend an integration time step equal to one-tenth of the highest period of significance to the system (see for example Section 7.2 of Structural Dynamics by Craig (Reference 7) and Section 5.5.2 of Reference 6. Assuming that 35 cps represents a still significant frequency for the RCS, this approach would lead to an integration time step of 0.00286 seconds, which is noticeably larger than the 0.00095 seconds actually used in the analyses. The plots contained in Section 5.5.2 of Reference 6 indicate that the error introduced into the calculated response is negligible when the integration time step divided by the period is 0.03325. The error in the calculated response decreases as the period increases, indicating that the error introduced by an integration time step of 0.00095 seconds is extremely small for the lower modes of the system, which provide the majority of the system response.

The responses obtained from analysis of the RCS linear model for the seismic cases are multiplied by the linear-to-non-linear factors described above before being used in the stress and fatigue analyses of the RCS components, piping and supports.

Seismic analysis of the RCS four loop structural model using any of the direct step-by-step time history solution techniques described in Appendix N of Section III to the ASME Boiler and Pressure Vessel Code (Reference 8) is an acceptable alternative to the process described above provided that RG 1.61 damping (represented by an

appropriate Rayleigh damping curve) and a suitably small integration time step are used.

#### **3C.4.2.2.2 Reactor Pressure Vessel Isolated Structural Model Seismic Analysis**

The SSE cases described in Section 3.7.1.3 are considered in the seismic analysis of the RPV isolated structural model.

Basemat translational and rotational excitations (acceleration time histories) in the three global directions are applied to the RPV isolated structural model, at the base of the RBIS, for each of the seismic cases. Application of all the seismic cases in the design basis seismic analysis of the RPV isolated structural model provides some coverage of uncertainties associated with the soil-structure interaction analysis and the model itself because each of the seismic cases tends to exhibit slightly different frequency characteristics, but relatively similar peak acceleration values, across much of the frequency range of interest to the RPV, its internals, and RPV CHE. To enhance this effect and to provide further coverage of uncertainties inherent in the analysis, the sets of seismic excitations are applied to three different configurations of the RPV isolated structural model: the first model configuration has the modulus of elasticity for the RBIS elements set at 70 percent of the nominal value, the second model configuration has the modulus of elasticity for the RBIS elements set at its nominal value, and the third model configuration has the modulus of elasticity for the RBIS elements set at 130 percent of the nominal value.

The seismic loads for the primary stress analysis of the RPV, its internals, and RPV CHE are generated from computer analyses through application of these seismic cases to the RPV isolated structural model with gaps at the locations indicated below explicitly represented in the model:

- Between the RPV and the upper support plate flange;
- Between the RPV and the core barrel flange;
- Between the RPV radial guides and the radial keys;
- Between the hold down spring, the upper support plate flange and the core barrel flange;
- Between the fuel assemblies in the central core area and the fuel assemblies in the peripheral core area; and
- Between the fuel assemblies in the peripheral core area and the heavy reflector.

Since the RPV isolated structural model is geometrically non-linear due to these gaps, the direct step-by-step integration time history solution technique with Rayleigh damping is utilized. The predicted seismic response that results from the use of a single

Rayleigh damping curve is overly conservative due to the wide range of model element damping ratios (from 3 percent for pressure vessels up to 30 percent for fuel assemblies). Therefore, several sets of Rayleigh damping constants ( $\alpha$ 's and  $\beta$ 's in Equation 3C-11) are determined and applied in the analysis in the same manner as described in Section 3C.4.2.1.

The integration time step used in these non-linear analyses is 0.0005 seconds. Such a small time step is required to ensure that the various gaps are properly accounted for in the solution. A time step study is performed where one SSE case is reanalyzed with the integration time step halved to 0.00025 seconds. The RCS response from this analysis is compared to that from the corresponding analysis with the original time step (0.0005 seconds). The maximum change in response is less than 6 percent, thereby validating the original integration time step (0.0005 seconds) as sufficient to allow convergence of the solution.

### **3C.4.3 Load Combinations**

The load combinations used in the stress analyses of the RCS piping, components, component internals, and component supports are described in Section 3.9.3.

### **3C.5 Amplified Response Spectra Generation**

Basemat acceleration time histories representing the SSE cases considered in the seismic analysis of the RCS four loop structural model are used to develop Amplified Response Spectra (ARS) at points of interest in the RCS. These include branch line nozzle locations on the RCS primary piping and components. The ARS are peak broadened by 15 percent in each direction per the guidance provided in RG 1.122. The ARS is generated for the various damping levels needed for seismic analysis of the attached piping (see Table 3.7.1-1). ARS is generated using the computer code RESPECT (see Section 3C.6). RESPECT generates ARS using input basemat time histories and the RCS structural properties as obtained from the BWSPAN output from the seismic analysis of the RCS four loop structural model.

### **3C.6 Description of Computer Programs**

The following computer programs are used in the loading analyses of the RCS four loop structural model and the RPV isolated structural model:

- BWHIST: This code converts pressure time histories generated by CRAFT2 and COMPAR2 into force time histories by integrating the pressures over the component area on which the pressure acts. BWHIST also orients the resulting force time history for direct input into BWSPAN. Earlier versions of BWHIST were certified by comparing the output from the analysis of sample problems to the results obtained from hand calculations for the same sample problems. As additional options were added to the code, test cases were run to confirm that results did not change from the previous version. BWHIST is a certified computer

code that is maintained in a controlled location (users can only access an executable file, not the source code).

- BWSPAN: Information on this computer code is provided in Section 3F.5.
- BWSPEC: This code tabulates displacements, pipe and structure loads, support loads, and spring loads for selected locations using output from a BWSPAN analysis. Tabulations can be made for static, response spectrum, and time history load cases. Earlier versions of BWSPEC were certified by comparing the results it generated using BWSPAN output from sample problems to the actual output from BWSPAN. As additional options were added to the code, test cases were run to confirm that results did not change from the previous version. BWSPEC is a personal computer based code that is verified, by comparing its output to the BWSPAN output from which it is reading, each time it is executed.
- CASS: This code performs structural analysis of general structures subjected to static and dynamic loading using finite element analysis techniques and is typically used to perform modal analysis of structures. CASS is a purchased code that runs on a personal computer that is verified, by comparing the results from analysis of a sample problem to the classical solution of the same problem, each time it is executed.
- COMPAR2: This code performs hydraulics analysis of fluid systems (generally containment cavities). The system is modeled as a series of control volumes and flow paths, so that the behavior of a pressure wave caused by a pipe break can be predicted. Pressure time histories can be obtained for any structure included in the model. COMPAR2 is the AREVA version of COMPARE-MOD1, which is described in NUREG-0609 as being applicable and conservative for use in Asymmetric Cavity Pressurization analyses. No difference exists between these two codes except that COMPAR2 provides an additional output file containing a tabulation of nodal pressures for subsequent input to BWHIST. COMPAR2 is certified, by comparing results obtained from analyses of test configurations to actual test data and to hand calculations. COMPAR2 is a certified computer code that is maintained in a controlled location (users can only access an executable file, not the source code).
- CRAFT2: This code performs hydraulics analysis of fluid systems including piping and components. The system is modeled as a series of control volumes and flow paths such that the behavior of a pressure wave caused by a pipe break can be predicted. Pressure time histories can be obtained at changes in area or changes in flow direction. The NRC has approved CRAFT2 for use in simulating the effect of pipe ruptures on the RCS (Reference 4). CRAFT2 is certified, by comparing results obtained from analyses of test configurations to actual test data and to hand calculations. As additional options were added to the code, test cases were run to confirm that results did not change from the previous version. CRAFT2 is a certified computer code that is maintained in a controlled location (users can only access an executable file, not the source code).
- EBDynamics: This code performs dynamic analysis of general structures and fluids subjected to dynamic loading and is typically used to find the time domain solution

of coupled fluid-structure problems. EBDynamics is a personal computer based program that is verified, by comparing the results from analysis of a sample problem to the classical solution of the same problem, each time it is executed.

- PCRandom: This code performs flow induced vibration analysis for random turbulence of structural shapes exposed to either parallel or cross flow thermal hydraulic conditions. The program finds the response of a structure to a pressure power spectral density function, based on finite element implementation of the acceptance integral method, and then integrates the response PSD with respect to the frequency to obtain the root mean square response at the selected finite element nodal locations. PCRandom is a personal computer based code that is verified, by comparing the results from analysis of a sample problem with the classical solution of the same problem, each time it is executed.
- PCStab2: This code performs flow induced vibration analysis for fluid-elastic instability of steam generator tube bundles or an array of cylindrical shapes. This program determines the fluid-elastic stability margin, which is the ratio of the critical velocity to the mode shaped weighted pitch velocity, at finite element node locations. PCStab2 is a personal computer based code that is verified, by comparing the results from analysis of a sample problem with the classical solution of the same problem, each time it is executed.
- P91232: This code calculates through-wall gradient temperatures and stresses given pipe or nozzle geometry and thermal characteristics (i.e., time dependant fluid temperature and film coefficients or flow rates). P91232 is a personal computer based code that is verified, by comparing results from analysis of sample problems to hand calculated results, each time it is executed.
- RESPECT: This code generates ARS given the frequency and mode characteristics of the system in question (from BWSPAN) and the acceleration time history applicable to the base of the structure. RESPECT is used to generate seismic ARS at the branch nozzle locations in a model of a piping system. Earlier versions of RESPECT were certified by comparing the output obtained from analysis of sample problems to results obtained from hand calculations for the same sample problems. As additional options were added to the code, test cases were run to confirm that results did not change from the previous version. RESPECT is a certified computer code that is maintained in a controlled location (users can only access an executable file, not the source code).

AREVA computer codes are certified (or verified), controlled and maintained per administrative procedure. Files are maintained that provide the software author, source code, dated version, program description, extent and limitation of the program application, and the solutions to the test problems described above.

### 3C.7

#### References

1. Deleted.
2. B. Brenneman, M.K. Au-Yang, "Fluid-Structure Dynamics with a Modal Hybrid Method," *Journal of Pressure Vessel Technology*, Vol. 114, pp. 133-138.

3. ANSI/ANS-58.2-1988, "Design Basis for Protection of Light Water Nuclear Power Plants Against the Effects of Postulated Pipe Rupture," American Nuclear Society, LaGrange Park, IL, 1988.
4. BAW-10132-A, "Analytical Methods Description - Reactor Coolant System Hydrodynamic Loadings During a Loss-of-Coolant Accident," Babcock & Wilcox, May 1979.
5. Numerical Methods in Finite Element Analysis, Bathe, K. J. and Wilson, E.L., Prentice Hall, Inc., Englewood Cliffs, New Jersey, 1976.
6. Design of Structures, Theory and Applications to Earthquake Engineering, Chopra, A.K., Prentice Hall, Inc., Englewood Cliffs, New Jersey, 1996.
7. Structural Dynamics, An Introduction to Computer Methods, Craig, R.R., John Wiley & Sons, New York, 1981.
8. ASME Boiler and Pressure Vessel Code, Section III, "Rules for Construction of Nuclear Facility Components," The American Society of Mechanical Engineers, 2004.

Figure 3C-1—RCS Primary Side Hydraulic Model

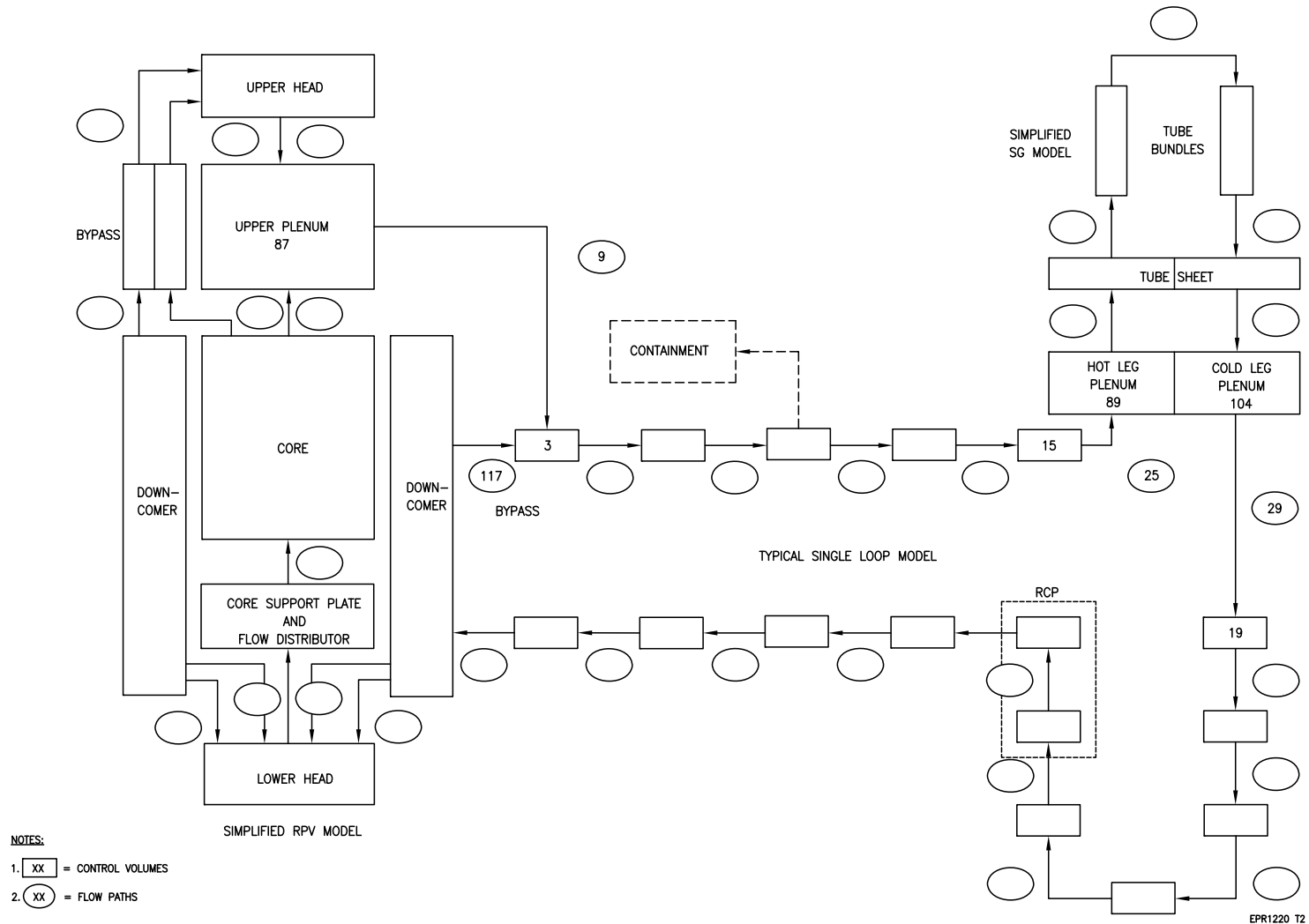
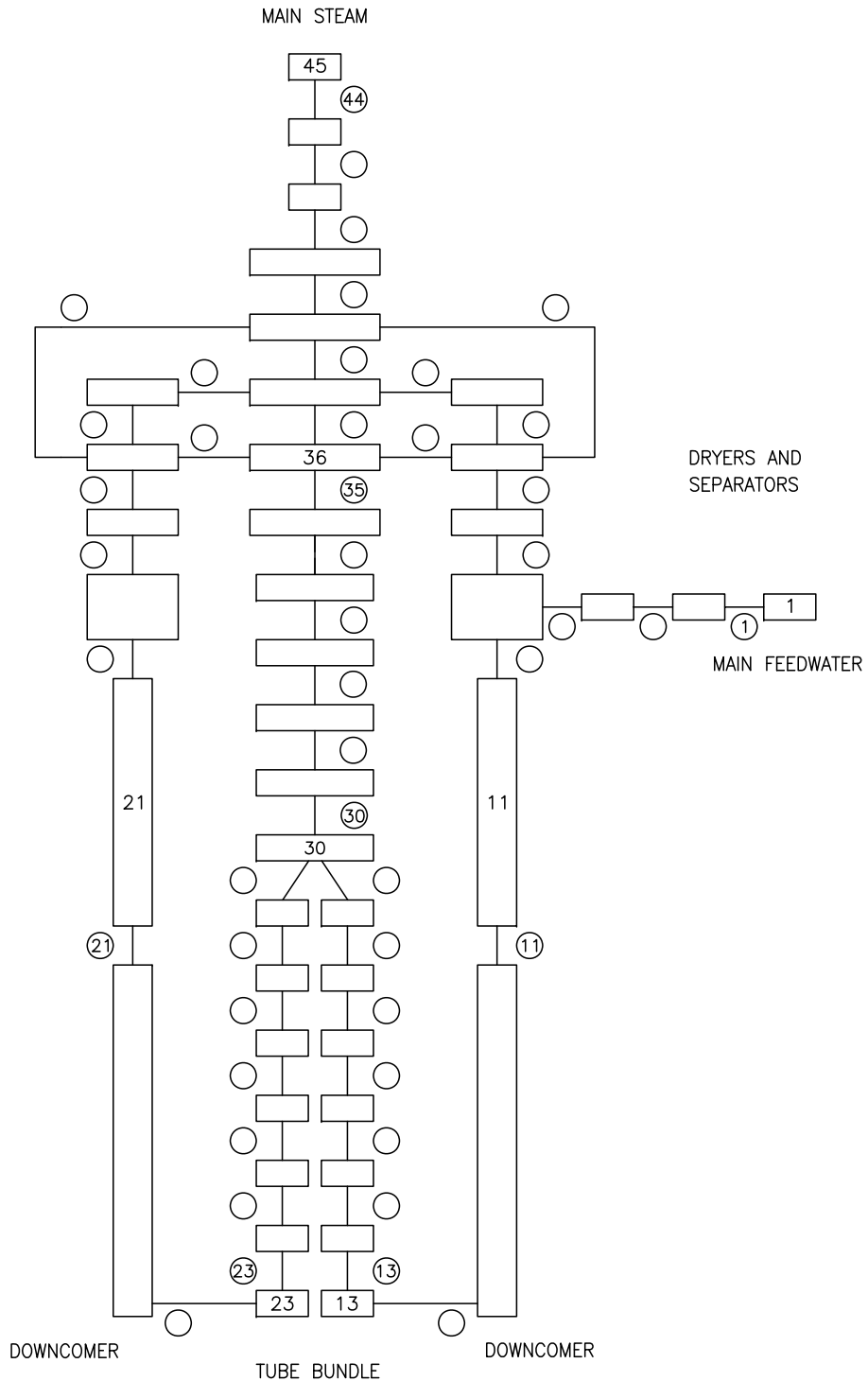

Figure 3C-2—SG Secondary Side Hydraulic Model



NOTES:

- 1. XX = CONTROL VOLUME
- 2. XX = FLOW PATH

EPR1225 T2



Figure 3C-3—RPV Isolated Hydraulic Model

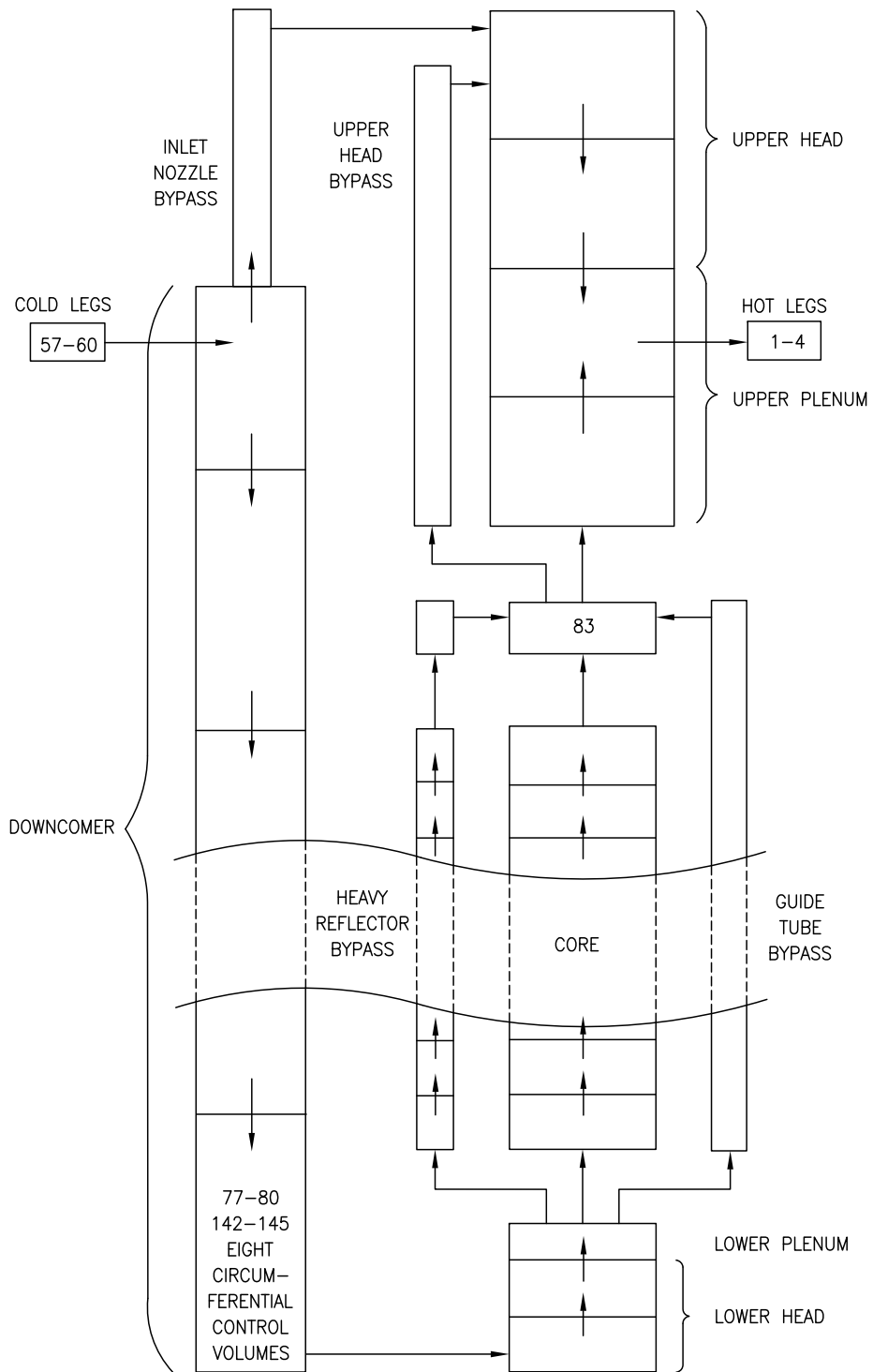

NOTES:

1. [ XX ] = CONTROL VOLUMES
2. —> = FLOW PATHS

EPR1230 T2

Figure 3C-4—ACP Hydraulic Model

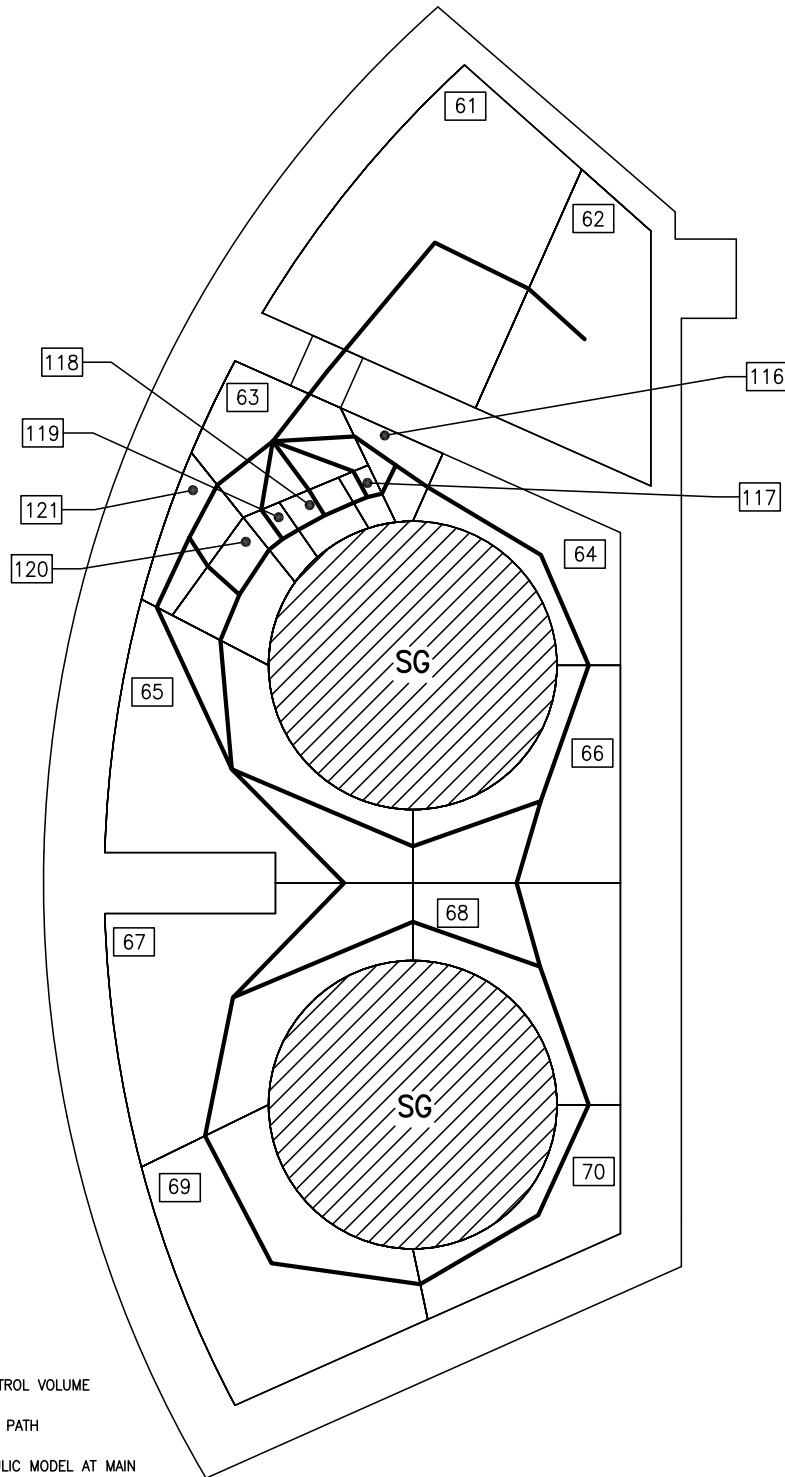

NOTES:

1. [XXX] = CONTROL VOLUME
2. — = FLOW PATH
3. CAVITY HYDRAULIC MODEL AT MAIN FEEDWATER NOZZLE ELEVATION
4. MAIN FEEDWATER NOZZLE IS IN CONTROL VOLUME 118

EPR1235 T2

[Next File](#)