

CHAPTER 5[†]: SHIELDING EVALUATION

5.0 INTRODUCTION

The shielding analysis of the HI-STORM 100 System, including the HI-STORM 100 overpack, HI-STORM 100S overpack, HI-STORM 100S Version B overpack^{††}, and the 100-ton (including the 100D) and 125-ton (including the 125D) HI-TRAC transfer casks, is presented in this chapter. The HI-STORM 100 System is designed to accommodate different MPCs within HI-STORM overpacks (the HI-STORM 100S overpack is a shorter version of the HI-STORM 100 overpack and the HI-STORM 100S Version B is shorter than both the HI-STORM 100 and 100S overpacks). The MPCs are designated as MPC-24, MPC-24E and MPC-24EF (24 PWR fuel assemblies), MPC-32 and MPC-32F (32 PWR fuel assemblies), and MPC-68, MPC-68F, and MPC-68FF (68 BWR fuel assemblies). The MPC-24E and MPC-24EF are essentially identical to the MPC-24 from a shielding perspective. Therefore only the MPC-24 is analyzed in this chapter. Likewise, the MPC-68, MPC-68F and MPC-68FF are identical from a shielding perspective as are the MPC-32 and MPC-32F and therefore only the MPC-68 and MPC-32 are analyzed. Throughout this chapter, unless stated otherwise, MPC-24 refers to either the MPC-24, MPC-24E, or MPC-24EF and MPC-32 refers to either the MPC-32 or MPC-32F and MPC-68 refers to the MPC-68, MPC-68F, and MPC-68FF.

In addition to storing intact PWR and BWR fuel assemblies, the HI-STORM 100 System is designed to store BWR and PWR damaged fuel assemblies and fuel debris. Damaged fuel assemblies and fuel debris are defined in Sections 2.1.3 and 2.1.9. Both damaged fuel assemblies and fuel debris are required to be loaded into Damaged Fuel Containers (DFCs).

The MPC-68, MPC-68F, and MPC-68FF are also capable of storing Dresden Unit 1 antimony-beryllium neutron sources and the single Thoria rod canister which contains 18 thoria rods that were irradiated in two separate fuel assemblies.

[†] This chapter has been prepared in the format and section organization set forth in Regulatory Guide 3.61. However, the material content of this chapter also fulfills the requirements of NUREG-1536. Pagination and numbering of sections, figures, and tables are consistent with the convention set down in *Chapter 1*, Section 1.0, herein. Finally, all terms-of-art used in this chapter are consistent with the terminology of the glossary (Table 1.0.1) and component nomenclature of the Bill-of-Materials (Section 1.5).

^{††} The HI-STORM 100S Version B was implemented in the HI-STORM FSAR (between Revisions 2 and 3) through the 10 CFR 72.48 process. The discussion of the HI-STORM 100S Version B and associated results were added to LAR 1014-2 at the end of the review cycle to support the NRC review of the radiation protection program proposed in the Certificate of Compliance in LAR 1014-2. The NRC did not review and approve any aspect of the design of the HI-STORM 100S Version B since it has been implemented under the provisions of 10 CFR 72.48.

HOLTEC INTERNATIONAL COPYRIGHTED MATERIAL

HI-STORM FSAR
REPORT HI-2002444

5.0-1

Rev. 11

PWR fuel assemblies may contain burnable poison rod assemblies (BPRAs) with any number of full-length rods and thimble plug rodlets in the locations without a full-length rod, thimble plug devices (TPDs), control rod assemblies (CRAs) or axial power shaping rod assemblies (APSRs), neutron source assemblies (NSAs) or similarly named devices. These non-fuel hardware devices are an integral part of PWR fuel assemblies and therefore the HI-STORM 100 System has been designed to store PWR fuel assemblies with or without these devices. Since each device occupies the same location within a fuel assembly, a single PWR fuel assembly will not contain multiple devices, with the exception of instrument tube tie rods (ITTRs), which may be stored in the assembly along with other types of non-fuel hardware.

In order to offer the user more flexibility in fuel storage, the HI-STORM 100 System offers two different loading patterns in the MPC-24, MPC-24E, MPC-24EF, MPC-32, MPC-32F, MPC-68, and the MPC-68FF. These patterns are uniform and regionalized loading as described in Section 2.0.1 and 2.1.6. Since the different loading patterns have different allowable burnup and cooling times combinations, both loading patterns are discussed in this chapter.

The sections that follow will demonstrate that the design of the HI-STORM 100 dry cask storage system fulfills the following acceptance criteria outlined in the Standard Review Plan, NUREG-1536 [5.2.1]:

Acceptance Criteria

1. The minimum distance from each spent fuel handling and storage facility to the controlled area boundary must be at least 100 meters. The “controlled area” is defined in 10CFR72.3 as the area immediately surrounding an ISFSI or monitored retrievable storage (MRS) facility, for which the licensee exercises authority regarding its use and within which ISFSI operations are performed.
2. The cask vendor must show that, during both normal operations and anticipated occurrences, the radiation shielding features of the proposed dry cask storage system are sufficient to meet the radiation dose requirements in Sections 72.104(a). Specifically, the vendor must demonstrate this capability for a typical array of casks in the most bounding site configuration. For example, the most bounding configuration might be located at the minimum distance (100 meters) to the controlled area boundary, without any shielding from other structures or topography.
3. Dose rates from the cask must be consistent with a well established “as low as reasonably achievable” (ALARA) program for activities in and around the storage site.
4. After a design-basis accident, an individual at the boundary or outside the controlled area shall not receive a dose greater than the limits specified in 10CFR 72.106.

HOLTEC INTERNATIONAL COPYRIGHTED MATERIAL

5. The proposed shielding features must ensure that the dry cask storage system meets the regulatory requirements for occupational and radiation dose limits for individual members of the public, as prescribed in 10 CFR Part 20, Subparts C and D.

This chapter contains the following information which demonstrates full compliance with the Standard Review Plan, NUREG-1536:

- A description of the shielding features of the HI-STORM 100 System, including the HI-TRAC transfer cask.
- A description of the bounding source terms.
- A general description of the shielding analysis methodology.
- A description of the analysis assumptions and results for the HI-STORM 100 System, including the HI-TRAC transfer cask.
- Analyses are presented for each MPC showing that the radiation dose rates follow As-Low-As-Reasonably-Achievable (ALARA) practices.
- The HI-STORM 100 System has been analyzed to show that the 10CFR72.104 and 10CFR72.106 controlled area boundary radiation dose limits are met during normal, off-normal, and accident conditions of storage for non-effluent radiation from illustrative ISFSI configurations at a minimum distance of 100 meters.
- Analyses are also presented which demonstrate that the storage of damaged fuel and fuel debris in the HI-STORM 100 System is acceptable during normal, off-normal, and accident conditions.

Chapter 2 contains a detailed description of structures, systems, and components important to safety.

Chapter 7 contains a discussion on the release of radioactive materials from the HI-STORM 100 System. Therefore, this chapter only calculates the dose from direct neutron and gamma radiation emanating from the HI-STORM 100 System.

Chapter 10, Radiation Protection, contains the following information:

- A discussion of the estimated occupational exposures for the HI-STORM 100 System, including the HI-TRAC transfer cask.
- A summary of the estimated radiation exposure to the public.

HOLTEC INTERNATIONAL COPYRIGHTED MATERIAL

HI-STORM FSAR
REPORT HI-2002444

5.0-3

Rev. 11

5.1 DISCUSSION AND RESULTS

The principal sources of radiation in the HI-STORM 100 System are:

- Gamma radiation originating from the following sources
 1. Decay of radioactive fission products
 2. Secondary photons from neutron capture in fissile and non-fissile nuclides
 3. Hardware activation products generated during core operations

- Neutron radiation originating from the following sources
 1. Spontaneous fission
 2. α,n reactions in fuel materials
 3. Secondary neutrons produced by fission from subcritical multiplication
 4. γ,n reactions (this source is negligible)
 5. Dresden Unit 1 antimony-beryllium neutron sources

During loading, unloading, and transfer operations, shielding from gamma radiation is provided by the steel structure of the MPC and the steel, lead, and water of the HI-TRAC transfer cask. For storage, the gamma shielding is provided by the MPC, and the steel and concrete of the overpack. Shielding from neutron radiation is provided by the concrete of the overpack during storage and by the water of the HI-TRAC transfer cask during loading, unloading, and transfer operations. Additionally, in the HI-TRAC 125 and 125D top lid and the transfer lid of the HI-TRAC 125, a solid neutron shielding material, Holtite-A is used to thermalize the neutrons. Boron carbide, dispersed in the solid neutron shield material utilizes the high neutron absorption cross section of ^{10}B to absorb the thermalized neutrons.

The shielding analyses were performed with MCNP-4A [5.1.1] developed by Los Alamos National Laboratory (LANL). The source terms for the design basis fuels were calculated with the SAS2H and ORIGEN-S sequences from the SCALE 4.3 system [5.1.2, 5.1.3]. A detailed description of the MCNP models and the source term calculations are presented in Sections 5.3 and 5.2, respectively.

The design basis zircaloy clad fuel assemblies used for calculating the dose rates presented in this chapter are B&W 15x15 and the GE 7x7, for PWR and BWR fuel types, respectively. The design basis intact 6x6 and mixed oxide (MOX) fuel assemblies are the GE 6x6. The GE 6x6 is also the design basis damaged fuel assembly for the Dresden Unit 1 and Humboldt Bay array classes. Section 2.1.9 specifies the acceptable intact zircaloy clad fuel characteristics and the acceptable damaged fuel characteristics.

HOLTEC INTERNATIONAL COPYRIGHTED MATERIAL

HI-STORM FSAR
REPORT HI-2002444

Rev. 12

5.1-1

The design basis stainless steel clad fuels are the WE 15x15 and the A/C 10x10, for PWR and BWR fuel types, respectively. Section 2.1.9 specifies the acceptable fuel characteristics of stainless steel clad fuel for storage.

The MPC-24, MPC-24E, MPC-24EF, MPC-32, MPC-32F, MPC-68, and MPC-68FF are qualified for storage of SNF with different combinations of maximum burnup levels and minimum cooling times. Section 2.1.9 specifies the acceptable maximum burnup levels and minimum cooling times for storage of zircaloy clad fuel in these MPCs. Section 2.1.9 also specifies the acceptable maximum burnup levels and minimum cooling times for storage of stainless steel clad fuel. The burnup and cooling time values in Section 2.1.9, which differ by array class, were chosen based on an analysis of the maximum decay heat load that could be accommodated within each MPC. Section 5.2 of this chapter describes the choice of the design basis fuel assembly based on a comparison of source terms and also provides a description of how the allowable burnup and cooling times were derived. Since for a given cooling time, different array classes have different allowable burnups in Section 2.1.9, burnup and cooling times that bound array classes 14x14A and 9x9G were used for the analysis in this chapter since these array class burnup and cooling time combinations bound the combinations from the other PWR and BWR array classes. Section 5.2.5 describes how this results in a conservative estimate of the maximum dose rates.

Section 2.1.9 specifies that the maximum assembly average burnup for PWR and BWR fuel is 68,200 and 65,000 MWD/MTU, respectively. The analysis in this chapter conservatively considers burnups up to 75,000 and 70,000 MWD/MTU for PWR and BWR fuel, respectively.

The burnup and cooling time combinations listed below bound all acceptable uniform and regionalized loading burnup levels and cooling times from Section 2.1.9. All combinations were analyzed in the HI-STORM overpack and HI-TRAC transfer casks.

Zircaloy Clad Fuel		
MPC-24	MPC-32	MPC-68
60,000 MWD/MTU 3 year cooling	45,000 MWD/MTU 3 year cooling	50,000 MWD/MTU 3 year cooling
69,000 MWD/MTU 4 year cooling	60,000 MWD/MTU 4 year cooling	62,000 MWD/MTU 4 year cooling
75,000 MWD/MTU 5 year cooling	69,000 MWD/MTU 5 year cooling	65,000 MWD/MTU 5 year cooling
		70,000 MWD/MTU 6 year cooling

HOLTEC INTERNATIONAL COPYRIGHTED MATERIAL

Stainless Steel Clad Fuel		
MPC-24	MPC-32	MPC-68
40,000 MWD/MTU 8 year cooling	40,000 MWD/MTU 9 year cooling	22,500 MWD/MTU 10 year cooling

Results are presented in this chapter for the single burnup and cooling time combination for zircaloy clad fuel from the above table which produces the highest dose rate at 1 meter from the midplane of the HI-STORM overpack and HI-TRAC transfer casks. The burnup and cooling time combination may be different for normal and accident conditions and for the different overpacks. As mentioned earlier, there are different versions of the HI-STORM overpack: the HI-STORM 100, the HI-STORM 100S, and the HI-STORM 100S Version B. Section 5.3 describes all three overpacks. However, since the HI-STORM 100S Version B overpack has higher dose rates at the inlet vents and slightly higher offsite dose rates than the other overpacks, results are only presented for the HI-STORM 100S Version B overpack.

The 100-ton HI-TRAC with the MPC-24 has higher normal condition dose rates at the mid-plane than the 100-ton HI-TRAC with the MPC-32 or the MPC-68. Therefore, the MPC-24 results are presented in this section and the MPC-24 was used for the dose exposure estimates in Chapter 10. The MPC-32 results, MPC-68 results, and additional MPC-24 results are provided in Section 5.4 for comparison. The 100-ton HI-TRAC with the MPC-24 also has higher accident condition dose rates at the mid-plane than the 100-ton HI-TRAC with the MPC-32 or the MPC-68. Therefore, the MPC-24 results for accident condition are presented in the section. Accident condition results for the MPC-32 and MPC-68 in the 100-ton HI-TRAC are not provided in this chapter. The HI-TRAC 100D is a variation on the 100-ton HI-TRAC with fewer radial ribs and a slightly different lower water jacket. Section 5.4 presents results for the HI-TRAC 100D with the MPC-32.

The HI-TRAC 100 and 100D dose rates bound the HI-TRAC 125 and 125D dose rates for the same burnup and cooling time combinations. Therefore, for illustrative purposes, the MPC-24 was the only MPC analyzed in the HI-TRAC 125 and 125D. Since the HI-TRAC 125D has fewer radial ribs, the dose rate at the midplane of the HI-TRAC 125D is higher than the dose rate at the midplane of the HI-TRAC 125. Therefore, the results on the radial surface are only presented for the HI-TRAC 125D in this chapter.

As a general statement, the dose rates for uniform loading presented in this chapter bound the dose rates for regionalized loading therefore, dose rates for specific burnup and cooling time combinations in a regionalized loading pattern are not presented in this chapter. For regionalized loading where higher burned or shorter cooled assemblies are placed in the center of the cask, the dose rates would be substantially lower than the bounding dose rates presented here. For regionalized loading where the higher burned or shorter cooled assemblies are placed on the

periphery, the dose rates could be closer to the bounding dose rates presented here. Section 5.4.9 provides an additional brief discussion on regionalized loading.

Unless otherwise stated all tables containing dose rates for design basis fuel refer to design basis intact zircaloy clad fuel.

5.1.1 Normal and Off-Normal Operations

Chapter 11 discusses the potential off-normal conditions and their effect on the HI-STORM 100 System. None of the off-normal conditions have any impact on the shielding analysis. Therefore, off-normal and normal conditions are identical for the purpose of the shielding evaluation.

The 10CFR72.104 criteria for radioactive materials in effluents and direct radiation during normal operations are:

1. During normal operations and anticipated occurrences, the annual dose equivalent to any real individual who is located beyond the controlled area, must not exceed 25 mrem to the whole body, 75 mrem to the thyroid and 25 mrem to any other critical organ.
2. Operational restrictions must be established to meet as low as reasonably achievable (ALARA) objectives for radioactive materials in effluents and direct radiation.

10CFR20 Subparts C and D specify additional requirements for occupational dose limits and radiation dose limits for individual members of the public. Chapter 10 specifically addresses these regulations.

In accordance with ALARA practices, design objective dose rates are established for the HI-STORM 100 System in Section 2.3.5.2 as: 300 mrem/hour on the radial surface of the overpack, 175 mrem/hour at the openings of the air vents, and 60 mrem/hour on the top of the overpack.

The HI-STORM overpack dose rates presented in this section are conservatively evaluated for the MPC-32, the MPC-68, and the MPC-24. All burnup and cooling time combinations analyzed bound the allowable burnup and cooling times specified in Section 2.1.9.

Figure 5.1.13 identifies the locations of the dose points referenced in the dose rate summary tables for the HI-STORM 100S Version B overpack. Dose Points #1 and #3 are the locations of the inlet and outlet air ducts, respectively. The dose values reported for these locations (adjacent and 1 meter) were averaged over the duct opening. Dose Point #4 is the peak dose location above the overpack shield block. For the adjacent top dose, this dose point is located over the air annulus between the MPC and the overpack. The dose values reported at the locations shown on Figure 5.1.13 are averaged over a region that is approximately 1 foot in width.

The total dose rates presented in this chapter for the MPC-24 and MPC-32 are presented for two cases: with and without BPRAs. The dose from the BPRAs was conservatively assumed to be the maximum calculated in Section 5.2.4.1. This is conservative because it is not expected that the cooling times for both the BPRAs and fuel assemblies would be such that they are both at the maximum design basis values.

Tables 5.1.11, 5.1.12, and 5.1.13 provide the maximum dose rates adjacent to the HI-STORM 100S Version B overpack during normal conditions for the MPC-32, MPC-24, and MPC-68. Tables 5.1.14 through 5.1.16 provide the maximum dose rates at one meter from the HI-STORM 100S Version B overpack.

The HI-STORM 100S Version B overpack was analyzed for the dose rate at the controlled area boundary. Although the dose rates for the MPC-32 in HI-STORM 100S Version B are greater than those for the MPC-24 in HI-STORM 100S Version B at the ventilation ducts, as shown in Tables 5.1.11 and 5.1.12, the MPC-24 was used in the calculations for the dose rates at the controlled area boundary for the HI-STORM 100S Version B overpack. This is acceptable because the vents are a small fraction of the radial surface area and the MPC-24 has higher dose rates at the radial midplane than the MPC-32 in the HI-STORM 100S Version B overpack. The MPC-24 was also chosen because, for a given cooling time, the MPC-24 has a higher allowable burnup than the MPC-32 or the MPC-68 (see Section 2.1.9). Consequently, for the allowable burnup and cooling times, the MPC-24 will have dose rates that are greater than or equivalent to those from the MPC-68 and MPC-32. The controlled area boundary dose rates were also calculated including the BPRA non-fuel hardware source. In the site specific dose analysis, users should perform an analysis which properly bounds the fuel to be stored including BPRAs if present. For guidance on fuel parameters for site-specific analyses see Subsection 5.2.5.4.

Table 5.1.7 provides dose rates adjacent to and one meter from the 100-ton HI-TRAC. Table 5.1.8 provides dose rates adjacent to and one meter from the 125-ton HI-TRACs. Figures 5.1.2 and 5.1.4 identify the locations of the dose points referenced in Tables 5.1.7 and 5.1.8 for the HI-TRAC 125 and 100 transfer casks, respectively. The dose rates listed in Tables 5.1.7 and 5.1.8 correspond to the normal condition in which the MPC is dry and the HI-TRAC water jacket is filled with water. The dose rates below the HI-TRAC (Dose Point #5) are provided for two conditions. The first condition is when the pool lid is in use and the second condition is when the transfer lid is in use. The HI-TRAC 125D does not utilize the transfer lid, rather it utilizes the pool lid in conjunction with the mating device. Therefore the dose rates reported for the pool lid are applicable to both the HI-TRAC 125 and 125D while the dose rates reported for the transfer lid are applicable only to the HI-TRAC 125. The calculational model of the 100-ton HI-TRAC included a concrete floor positioned 6 inches (the typical carry height) below the pool lid to account for ground scatter. As a result of the modeling, the dose rate at 1 meter from the pool lid for the 100-ton HI-TRAC was not calculated. The dose rates provided in Tables 5.1.7 and 5.1.8 are for the MPC-24 with design basis fuel at burnups and cooling times, based on the allowed burnup and cooling times specified in Section 2.1.9, that result in dose rates that are generally higher in each of the two HI-TRAC designs. The burnup and cooling time combination used for

both the 100-ton and 125-ton HI-TRAC was chosen to bound the allowable burnup and cooling times in Section 2.1.9. Results for other burnup and cooling times and for the MPC-68 and MPC-32 are provided in Section 5.4.

Because the dose rates for the 100-ton HI-TRAC transfer cask are significantly higher than the dose rates for the 125-ton HI-TRACs or the HI-STORM overpack, it is important to understand the behavior of the dose rates surrounding the external surface. To assist in this understanding, several figures, showing the dose rate profiles on the top, bottom and sides of the 100-ton HI-TRAC transfer cask, are presented below. The figures discussed below were all calculated without the gamma source from BPRAs and were calculated for an earlier design of the HI-TRAC which utilized 30 steel fins 0.375 inches thick compared to 10 steel fins 1.25 inches thick. The change in rib design only affects the magnitude of the dose rates presented for the radial surface but does not affect the conclusions discussed below.

Figure 5.1.5 shows the dose rate profile at 1 foot from the side of the 100-ton HI-TRAC transfer cask with the MPC-24 for 35,000 MWD/MTU and 5 year cooling. This figure clearly shows the behavior of the total dose rate and each of the dose components as a function of the cask height. To capture the effect of scattering off the concrete floor, the calculational model simulates the 100-ton HI-TRAC at a height of 6 inches (the typical cask carry height) above the concrete floor. As expected, the total dose rate on the side near the top and bottom is dominated by the Co-60 gamma dose component, while the center dose rate is dominated by the fuel gamma dose component.

The total dose rate and individual dose rate components on the surface of the pool lid on the HI-TRAC-100 when uniformly loaded are provided in Figure 5.1.6, illustrating the significant reduction in dose rate with increasing distance from the center of the pool lid. Specifically, the total dose rate is shown to drop by a factor of more than 20 from the center of the pool lid to the outer edge of the HI-TRAC. Therefore, even though the dose rate in Table 5.1.7 at the center of the pool lid is substantial, the dose rate contribution, from the pool lid, to the personnel exposure is minimal.

The behavior of the dose rate 1-foot from the transfer lid is shown in Figure 5.1.7. Similarly, the total dose rate and the individual dose rate components 1-foot from the top lid, as a function of distance from the axis of the 100-ton HI-TRAC, are shown in Figure 5.1.8. For both lids (transfer and top), the reduction in dose rate with increased distance from the cask axial centerline is substantial.

Note that regionalized loading can have a significant effect on the variation of the dose rate on the top and bottom as a function of the distance from the cask centerline. For a regionalized loading with higher burnup fuel in the center region, the dose rate profiles would be even more pronounced, i.e. the difference between the dose rate in the center and the dose rate near the edge of the cask would be larger than shown in Figures 5.1.7 and 5.1.8. However, if a regionalized loading plan is selected where the higher burnup fuel is located in the outer region, then the

difference would be less. In extreme cases, it would even be possible that the dose rate near the edge of the MPC is higher than the one at the center of the cask. This should be considered during loading operations in order to minimize occupational doses.

To reduce the dose rate above the water jacket, a localized temporary shield ring, described in Chapter 8, may be employed on the 125-ton HI-TRACs and on the 100-ton HI-TRAC. This temporary shielding, which is water, essentially extends the water jacket to the top of the HI-TRAC. The effect of the temporary shielding on the side dose rate above the water jacket (in the area around the lifting trunnions and the upper flange) is shown on Figure 5.1.9, which shows the dose profile on the side of the 100-ton HI-TRAC with the temporary shielding installed. For comparison, the total dose rate without temporary shielding installed is also shown on Figure 5.1.9. The results indicate that the temporary shielding reduces the dose rate by approximately a factor of 2 in the area above the water jacket.

To illustrate the reduction in dose rate with distance from the side of the 100-ton HI-TRAC, Figure 5.1.10 shows the total dose rate on the surface and at distances of 1-foot and 1-meter.

Figure 5.1.11 plots the total dose rate at various distances from the bottom of the transfer lid, including distances of 1, 5, 10, and 15 feet. Near the transfer lid, the total dose rate is shown to decrease significantly as a function of distance from the 100-ton HI-TRAC axial centerline. Near the axis of the HI-TRAC, the reduction in dose rate from the 1-foot distance to the 15-foot distance is approximately a factor of 15. The dose rate beyond the radial edge of the HI-TRAC is also shown to be relatively low at all distances from the HI-TRAC transfer lid. Thus, prudent transfer operating procedures will employ the use of distance to reduce personnel exposure. In addition, when the HI-TRAC is in the horizontal position and is being transported on site, a missile shield may be positioned in front of the HI-TRAC transfer lid or pool lid. If present, this shield would also serve as temporary gamma shielding which would greatly reduce the dose rate in the vicinity of the transfer lid or pool lid. For example, if the missile shield was a 2 inch thick steel plate, the gamma dose rate would be reduced by approximately 90%.

The dose to any real individual at or beyond the controlled area boundary is required to be below 25 mrem per year. The minimum distance to the controlled area boundary is 100 meters from the ISFSI. As mentioned, only the MPC-24 was used in the calculation of the dose rates at the controlled area boundary. Table 5.1.9 presents the annual dose to an individual from a single HI-STORM 100S Version B cask and various storage cask arrays, assuming an 8760 hour annual occupancy at the dose point location. The minimum distance required for the corresponding dose is also listed. These values were conservatively calculated for a burnup of 60,000 MWD/MTU and a 3-year cooling time. In addition, the annual dose was calculated for a burnup of 45,000 MWD/MTU with a corresponding cooling time of 9 years. BPRAs were included in these dose estimates. It is noted that these data are provided for illustrative purposes only. A detailed site-specific evaluation of dose at the controlled area boundary must be performed for each ISFSI in accordance with 10CFR72.212. The site-specific evaluation will consider dose from other portions of the facility and will consider the actual conditions of the fuel being stored (burnup

and cooling time). For guidance on fuel parameters for site-specific analyses see Subsection 5.2.5.4.

Figure 5.1.3 is an annual dose versus distance graph for the HI-STORM 100 cask array configurations provided in Table 5.1.9. This curve, which is based on an 8760 hour occupancy, is provided for illustrative purposes only and will be re-evaluated on a site-specific basis.

Section 5.2 lists the gamma and neutron sources for the design basis fuels. Since the source strengths of the GE 6x6 intact and damaged fuel and the GE 6x6 MOX fuel are significantly smaller in all energy groups than the intact design basis fuel source strengths, the dose rates from the GE 6x6 fuels for normal conditions are bounded by the MPC-68 analysis with the design basis intact fuel. Therefore, no explicit analysis of the MPC-68 with either GE 6x6 intact or damaged or GE 6x6 MOX fuel for normal conditions is required to demonstrate that the MPC-68 with GE 6x6 fuels will meet the normal condition regulatory requirements. Section 5.4.2 evaluates the effect of generic damaged fuel in the MPC-24E, MPC-32 and the MPC-68.

Section 5.2.6 lists the gamma and neutron sources from the Dresden Unit 1 Thoria rod canister and demonstrates that the Thoria rod canister is bounded by the design basis Dresden Unit 1 6x6 intact fuel.

Section 5.2.4 presents the Co-60 sources from the BPRAs, TPDs, CRAs and APSRs that are permitted for storage in the HI-STORM 100 System. Section 5.4.6 discusses the increase in dose rate as a result of adding non-fuel hardware in the MPCs.

Section 5.4.7 demonstrates that the Dresden Unit 1 fuel assemblies containing antimony-beryllium neutron sources are bounded by the shielding analysis presented in this section.

Section 5.2.3 lists the gamma and neutron sources for the design basis stainless steel clad fuel. The dose rates from this fuel are provided in Section 5.4.4.

The analyses summarized in this section demonstrate that the HI-STORM 100 System, including the HI-TRAC transfer cask, are in compliance with the 10CFR72.104 limits and ALARA practices.

5.1.2 Accident Conditions

The 10CFR72.106 radiation dose limits at the controlled area boundary for design basis accidents are:

Any individual located on or beyond the nearest boundary of the controlled area may not receive from any design basis accident the more limiting of a total effective dose equivalent of 5 Rem, or the sum of the deep-dose equivalent and the committed dose equivalent to any individual organ or tissue (other than the lens of the eye) of 50 Rem.

HOLTEC INTERNATIONAL COPYRIGHTED MATERIAL

The lens dose equivalent shall not exceed 15 Rem and the shallow dose equivalent to skin or to any extremity shall not exceed 50 Rem. The minimum distance from the spent fuel or high-level radioactive waste handling and storage facilities to the nearest boundary of the controlled area shall be at least 100 meters.

Design basis accidents which may affect the HI-STORM overpack can result in limited and localized damage to the outer shell and radial concrete shield. As the damage is localized and the vast majority of the shielding material remains intact, the effect on the dose at the site boundary is negligible. Therefore, the site boundary, adjacent, and one meter doses for the loaded HI-STORM overpack for accident conditions are equivalent to the normal condition doses, which meet the 10CFR72.106 radiation dose limits.

The design basis accidents analyzed in Chapter 11 have one bounding consequence that affects the shielding materials of the HI-TRAC transfer cask. It is the potential for damage to the water jacket shell and the loss of the neutron shield (water). In the accident consequence analysis, it is conservatively assumed that the neutron shield (water) is completely lost and replaced by a void.

Throughout all design basis accident conditions the axial location of the fuel will remain fixed within the MPC because of the fuel spacers. The HI-STAR 100 System (Docket Number 72-1008) documentation provides analysis to demonstrate that the fuel spacers will not fail under any normal, off-normal, or accident condition of storage. Chapter 3 also shows that the HI-TRAC inner shell, lead, and outer shell remain intact throughout all design basis accident conditions. Localized damage of the HI-TRAC outer shell could be experienced. However, the localized deformations will have only a negligible impact on the dose rate at the boundary of the controlled area.

The complete loss of the HI-TRAC neutron shield significantly affects the dose at mid-height (Dose Point #2) adjacent to the HI-TRAC. Loss of the neutron shield has a small effect on the dose at the other dose points. To illustrate the impact of the design basis accident, the dose rates at Dose Point #2 (see Figures 5.1.2 and 5.1.4) are provided in Table 5.1.10 for the 100-ton and 125-ton HI-TRACs at a distance of 1 meter and for the 100-ton HI-TRAC at a distance of 100 meters. The normal condition dose rates are provided for reference. Table 5.1.10 provides a comparison of the normal and accident condition dose rates at one meter from the HI-TRAC. The burnup and cooling time combinations used in Table 5.1.10 were the combinations that resulted in the highest post-accident condition dose rates. These burnup and cooling time combinations do not necessarily correspond to the burnup and cooling time combinations that result in the highest dose rate during normal conditions. Based on the dose rate at 100 meters in Table 5.1.10, it would take 1608 hours (~67 days) for the dose at the controlled area boundary to reach 5 Rem. Assuming an accident duration of 30 days, the accumulated dose at the controlled area boundary would be 2.2Rem. Based on this dose rate and the short duration of use for the loaded HI-TRAC transfer cask, it is evident that the dose as a result of the design basis accident cannot exceed 5 Rem at the controlled area boundary for the short duration of the accident.

The consequences of the design basis accident conditions for the MPC-68 and MPC-24E storing damaged fuel and/or fuel debris differ slightly from those with intact fuel. It is conservatively assumed that during a drop accident (vertical, horizontal, or tip-over) the damaged fuel collapses and the pellets rest in the bottom of the damaged fuel container. Analyses in Section 5.4.2 demonstrates that the damaged fuel in the post-accident condition does not significantly affect the dose rates around the cask. Therefore, the damaged fuel post-accident dose rates are bounded by the intact fuel post-accident dose rates.

Analyses summarized in this section demonstrate that the HI-STORM 100 System, including the HI-TRAC transfer cask, are in compliance with the 10CFR72.106 limits.

Table 5.1.1

[INTENTIONALLY DELETED]

HOLTEC INTERNATIONAL COPYRIGHTED MATERIAL

HI-STORM FSAR
REPORT HI-2002444

Rev. 12

5.1-11

HI-STORM 100 FSAR, NON-PROPRIETARY
REVISION 12
MARCH 12, 2014

Table 5.1.2

[INTENTIONALLY DELETED]

Table 5.1.3

[INTENTIONALLY DELETED]

Table 5.1.4

[INTENTIONALLY DELETED]

HOLTEC INTERNATIONAL COPYRIGHTED MATERIAL

HI-STORM FSAR
REPORT HI-2002444

Rev. 12

Table 5.1.5

[INTENTIONALLY DELETED]

HOLTEC INTERNATIONAL COPYRIGHTED MATERIAL

HI-STORM FSAR
REPORT HI-2002444

Rev. 12

5.1-15

Table 5.1.6

[INTENTIONALLY DELETED]

HOLTEC INTERNATIONAL COPYRIGHTED MATERIAL

HI-STORM FSAR
REPORT HI-2002444

Rev. 12

5.1-16

HI-STORM 100 FSAR, NON-PROPRIETARY
REVISION 12
MARCH 12, 2014

Table 5.1.7

DOSE RATES FROM THE 100-TON HI-TRAC FOR NORMAL CONDITIONS
MPC-24 DESIGN BASIS ZIRCALOY CLAD FUEL
60,000 MWD/MTU AND 3-YEAR COOLING

Dose Point Location	Fuel Gammas (mrem/hr)	(n, γ) Gammas (mrem/hr)	⁶⁰ Co Gammas (mrem/hr)	Neutrons (mrem/hr)	Totals (mrem/hr)	Totals with BPRAs (mrem/hr)
ADJACENT TO THE 100-TON HI-TRAC						
1	124.94	33.16	958.00	469.38	1585.48	1594.02
2	3196.67 [†]	134.95	0.96	249.02	3581.60	3828.84
3	36.47	6.50	528.22	392.74	963.94	1112.46
3 (temp)	16.31	11.57	244.83	6.31	279.02	347.16
4	80.38	2.57	425.12	483.50	991.57	1116.07
4 (outer)	23.94	1.63	105.85	326.35	457.77	489.10
5 (pool lid)	623.98	47.34	4826.78	3152.66	8650.76	8715.53
5 (transfer)	1243.30	2.59	7192.64	1805.36	10243.89	10340.73
5(t-outer)	318.58	0.89	696.19	713.29	1728.95	1750.42
ONE METER FROM THE 100-TON HI-TRAC						
1	422.99	17.82	142.41	76.30	659.52	692.00
2	1400.26 [†]	41.25	11.27	93.37	1546.14	1655.62
3	177.50	9.93	118.30	36.64	342.37	391.80
3 (temp)	176.53	10.66	100.76	13.85	301.80	346.37
4	27.82	0.45	131.25	120.44	279.96	318.53
5 (transfer)	552.69	0.48	2938.22	503.83	3995.21	4034.34
5(t-outer)	76.44	1.54	264.85	144.64	487.47	491.37

Notes:

- Refer to Figures 5.1.2 and 5.1.4 for dose locations.
- Dose location 3(temp) represents dose location 3 with temporary shielding installed.
- Dose location 4(outer) is the radial segment at dose location 4 which is 18-30 inches from the center of the overpack.
- Dose location 5(t-outer) is the radial segment at dose location 5 (transfer lid) which is 30-42 and 54-66 inches from the center of the lid for the adjacent and one meter locations, respectively. The inner radius of the HI-TRAC is 34.375 in. and the outer radius of the water jacket is 44.375 in.
- Dose rate based on no water within the MPC. For the majority of the duration that the HI-TRAC pool lid is installed, the MPC cavity will be flooded with water. The water within the MPC greatly reduces the dose rate.

[†] The cobalt activation of incore grid spacers accounts for approximately 6% of the surface and one-meter dose rates.

HOLTEC INTERNATIONAL COPYRIGHTED MATERIAL

HI-STORM FSAR
REPORT HI-2002444

Rev. 12

5.1-17

Table 5.1.8

DOSE RATES FROM THE 125-TON HI-TRACS FOR NORMAL CONDITIONS
MPC-24 DESIGN BASIS ZIRCALOY CLAD FUEL
75,000 MWD/MTU AND 5-YEAR COOLING

Dose Point Location	Fuel Gammas (mrem/hr)	(n, γ) Gammas (mrem/hr)	⁶⁰ Co Gammas (mrem/hr)	Neutrons (mrem/hr)	Totals (mrem/hr)	Totals with BPRAs (mrem/hr)
ADJACENT TO THE 125-TON HI-TRACS						
1	6.32	61.85	100.63	415.90	584.70	585.42
2	113.33 [†]	183.20	0.01	287.94	584.49	600.36
3	1.41	6.55	62.26	663.65	733.88	753.59
4	41.57	8.40	340.67	767.94	1158.58	1274.01
4 (outer)	4.84	6.00	42.31	16.11	69.26	83.45
5 (pool)	54.77	3.67	454.56	2883.53	3396.53	3404.24
5 (transfer)	65.81	4.78	601.40	440.29	1112.28	1117.76
ONE METER FROM THE 125-TON HI-TRACS						
1	14.93	24.68	12.90	68.44	120.95	122.99
2	50.47 [†]	59.39	0.52	98.23	208.61	215.68
3	5.66	13.95	12.58	61.07	93.26	98.17
4	11.54	2.03	82.02	79.09	174.68	202.33
5 (transfer)	25.98	0.92	290.76	76.26	393.92	396.85

Notes:

- Refer to Figures 5.1.2 and 5.1.4 for dose locations.
- Dose location 4(outer) is the radial segment at dose location 4 which is 18-24 inches from the center of the overpack.
- Dose rate based on no water within the MPC. For the majority of the duration that the HI-TRAC pool lid is installed, the MPC cavity will be flooded with water. The water within the MPC greatly reduces the dose rate.

[†] The cobalt activation of incore grid spacers accounts for 9.4% of the surface and one-meter dose rates.

HOLTEC INTERNATIONAL COPYRIGHTED MATERIAL

HI-STORM FSAR
REPORT HI-2002444

Rev. 12

5.1-18

Table 5.1.9

DOSE RATES FOR ARRAYS OF MPC-24
WITH DESIGN BASIS ZIRCALOY CLAD FUEL
AT VARYING BURNUP AND COOLING TIMES

Array Configuration	1 cask	2x2	2x3	2x4	2x5
HI-STORM 100S Version B Overpack					
60,000 MWD/MTU AND 3-YEAR COOLING					
Annual Dose (mrem/year) [†]	19.26	16.41	24.62	20.36	16.34
Distance to Controlled Area Boundary (meters) ^{††,†††}	350	450	450	500	550
45,000 MWD/MTU AND 9-YEAR COOLING					
Annual Dose (mrem/year) [†]	23.56	14.30	21.46	15.89	19.86
Distance to Controlled Area Boundary (meters) ^{††}	200	300	300	350	350

† 8760 hr. annual occupancy is assumed.

†† Dose location is at the center of the long side of the array.

††† Actual controlled area boundary dose rates will be lower because the maximum permissible burnup for 3-year cooling, as specified in the Section 2.1.9, is lower than the burnup used for this analysis.

HOLTEC INTERNATIONAL COPYRIGHTED MATERIAL

HI-STORM FSAR
REPORT HI-2002444

Rev. 12

5.1-19

Table 5.1.10

DOSE RATES FROM HI-TRAC
FOR ACCIDENT CONDITIONS
MPC-24 DESIGN BASIS ZIRCALOY CLAD FUEL
AT BOUNDING BURNUP AND COOLING TIMES

Dose Point [†] Location	Fuel Gammas ^{††} (mrem/hr)	⁶⁰ Co Gammas (mrem/hr)	Neutrons (mrem/hr)	Totals (mrem/hr)	Totals with BPRAs (mrem/hr)
ONE METER FROM HI-TRAC					
125-TON HI-TRACs					
75,000 MWD/MTU AND 5-YEAR COOLING					
2 (Accident Condition)	92.26	1.02	3476.98	3570.26	3583.16
2 (Normal Condition)	109.86	0.52	98.23	208.61	215.68
100-TON HI-TRAC					
75,000 MWD/MTU AND 5-YEAR COOLING					
2 (Accident Condition)	1354.67	17.88	4359.16	5731.72	5927.95
2 (Normal Condition)	829.09	9.90	168.82	1007.81	1117.29
100 METERS FROM HI-TRAC					
100-TON HI-TRAC					
75,000 MWD/MTU AND 5-YEAR COOLING					
2 (Accident Condition)	0.68	0.10	2.22	3.00	3.11

[†] Refer to Figures 5.1.2 and 5.1.4.

^{††} Gammas generated by neutron capture are included with fuel gammas.

HOLTEC INTERNATIONAL COPYRIGHTED MATERIAL

HI-STORM FSAR
REPORT HI-2002444

Rev. 12

Table 5.1.11

DOSE RATES ADJACENT TO HI-STORM 100S VERSION B OVERPACK
 FOR NORMAL CONDITIONS
 MPC-32 DESIGN BASIS ZIRCALOY CLAD FUEL AT BOUNDING
 BURNUP AND COOLING TIME
 45,000 MWD/MTU AND 3-YEAR COOLING

Dose Point [†] Location	Fuel Gammas ^{††} (mrem/hr)	⁶⁰ Co Gammas (mrem/hr)	Neutrons (mrem/hr)	Totals (mrem/hr)	Totals with BPRAs (mrem/hr)
1	41.37	70.98	14.80	127.15	130.10
2	239.51	0.32	4.24	244.08	261.07
3	11.22	17.82	5.51	34.54	40.95
4	12.02	4.29	4.11	20.43	22.78

[†] Refer to Figure 5.1.13.

^{††} Gammas generated by neutron capture are included with fuel gammas.

Table 5.1.12

DOSE RATES ADJACENT TO HI-STORM 100S VERSION B OVERPACK
 FOR NORMAL CONDITIONS
 MPC-24 DESIGN BASIS ZIRCALOY CLAD FUEL AT BOUNDING
 BURNUP AND COOLING TIME
 60,000 MWD/MTU AND 3-YEAR COOLING

Dose Point [†] Location	Fuel Gammas ^{††} (mrem/hr)	⁶⁰ Co Gammas (mrem/hr)	Neutrons (mrem/hr)	Totals (mrem/hr)	Totals with BPRAs (mrem/hr)
1	34.25	57.09	29.86	121.20	122.67
2	252.16	0.10	7.16	259.41	273.60
3	13.56	15.57	9.82	38.94	43.90
4	13.42	4.65	7.22	25.29	27.30

[†] Refer to Figure 5.1.13.

^{††} Gammas generated by neutron capture are included with fuel gammas.

Table 5.1.13

DOSE RATES ADJACENT TO HI-STORM 100S VERSION B OVERPACK
 FOR NORMAL CONDITIONS
 MPC-68 DESIGN BASIS ZIRCALOY CLAD FUEL AT BOUNDING
 BURNUP AND COOLING TIME
 50,000 MWD/MTU AND 3-YEAR COOLING

Dose Point [†] Location	Fuel Gammas ^{††} (mrem/hr)	⁶⁰ Co Gammas (mrem/hr)	Neutrons (mrem/hr)	Totals (mrem/hr)
1	20.15	56.22	18.80	95.17
2	211.31	0.12	6.38	217.81
3	4.39	18.15	3.73	26.27
4	7.76	5.05	3.40	16.20

† Refer to Figure 5.1.13.

†† Gammas generated by neutron capture are included with fuel gammas.

HOLTEC INTERNATIONAL COPYRIGHTED MATERIAL

HI-STORM FSAR
 REPORT HI-2002444

Rev. 12

Table 5.1.14

DOSE RATES AT ONE METER FROM HI-STORM 100S VERSION B OVERPACK
 FOR NORMAL CONDITIONS
 MPC-32 DESIGN BASIS ZIRCALOY CLAD FUEL AT BOUNDING
 BURNUP AND COOLING TIME
 45,000 MWD/MTU AND 3-YEAR COOLING

Dose Point [†] Location	Fuel Gammas ^{††} (mrem/hr)	⁶⁰ Co Gammas (mrem/hr)	Neutrons (mrem/hr)	Totals (mrem/hr)	Totals with BPRAs (mrem/hr)
1	32.51	18.19	2.41	53.10	55.78
2	124.98	1.42	1.75	128.15	136.88
3	14.74	8.67	0.75	24.16	28.13
4	2.79	1.31	1.16	5.26	5.89

† Refer to Figure 5.1.13.

†† Gammas generated by neutron capture are included with fuel gammas.

Table 5.1.15

DOSE RATES AT ONE METER FROM HI-STORM 100S VERSION B OVERPACK
 FOR NORMAL CONDITIONS
 MPC-24 DESIGN BASIS ZIRCALOY CLAD FUEL AT BOUNDING
 BURNUP AND COOLING TIME
 60,000 MWD/MTU AND 3-YEAR COOLING

Dose Point [†] Location	Fuel Gammas ^{††} (mrem/hr)	⁶⁰ Co Gammas (mrem/hr)	Neutrons (mrem/hr)	Totals (mrem/hr)	Totals with BPRAs (mrem/hr)
1	33.12	16.07	4.80	54.00	55.76
2	129.84	1.15	2.84	133.83	141.21
3	15.89	7.23	1.30	24.42	27.44
4	3.22	1.41	2.36	6.99	7.54

[†] Refer to Figure 5.1.13.

^{††} Gammas generated by neutron capture are included with fuel gammas.

HOLTEC INTERNATIONAL COPYRIGHTED MATERIAL

Table 5.1.16

DOSE RATES AT ONE METER FROM HI-STORM 100S VERSION B OVERPACK
 FOR NORMAL CONDITIONS
 MPC-68 DESIGN BASIS ZIRCALOY CLAD FUEL AT BOUNDING
 BURNUP AND COOLING TIME
 50,000 MWD/MTU AND 3-YEAR COOLING

Dose Point [†] Location	Fuel Gammas ^{††} (mrem/hr)	⁶⁰ Co Gammas (mrem/hr)	Neutrons (mrem/hr)	Totals (mrem/hr)
1	25.76	15.91	3.21	44.88
2	107.43	0.95	2.46	110.84
3	7.78	8.96	0.73	17.47
4	1.78	1.65	0.84	4.27

[†] Refer to Figure 5.1.13.

^{††} Gammas generated by neutron capture are included with fuel gammas.

HOLTEC INTERNATIONAL COPYRIGHTED MATERIAL

HI-STORM FSAR
 REPORT HI-2002444

Rev. 12

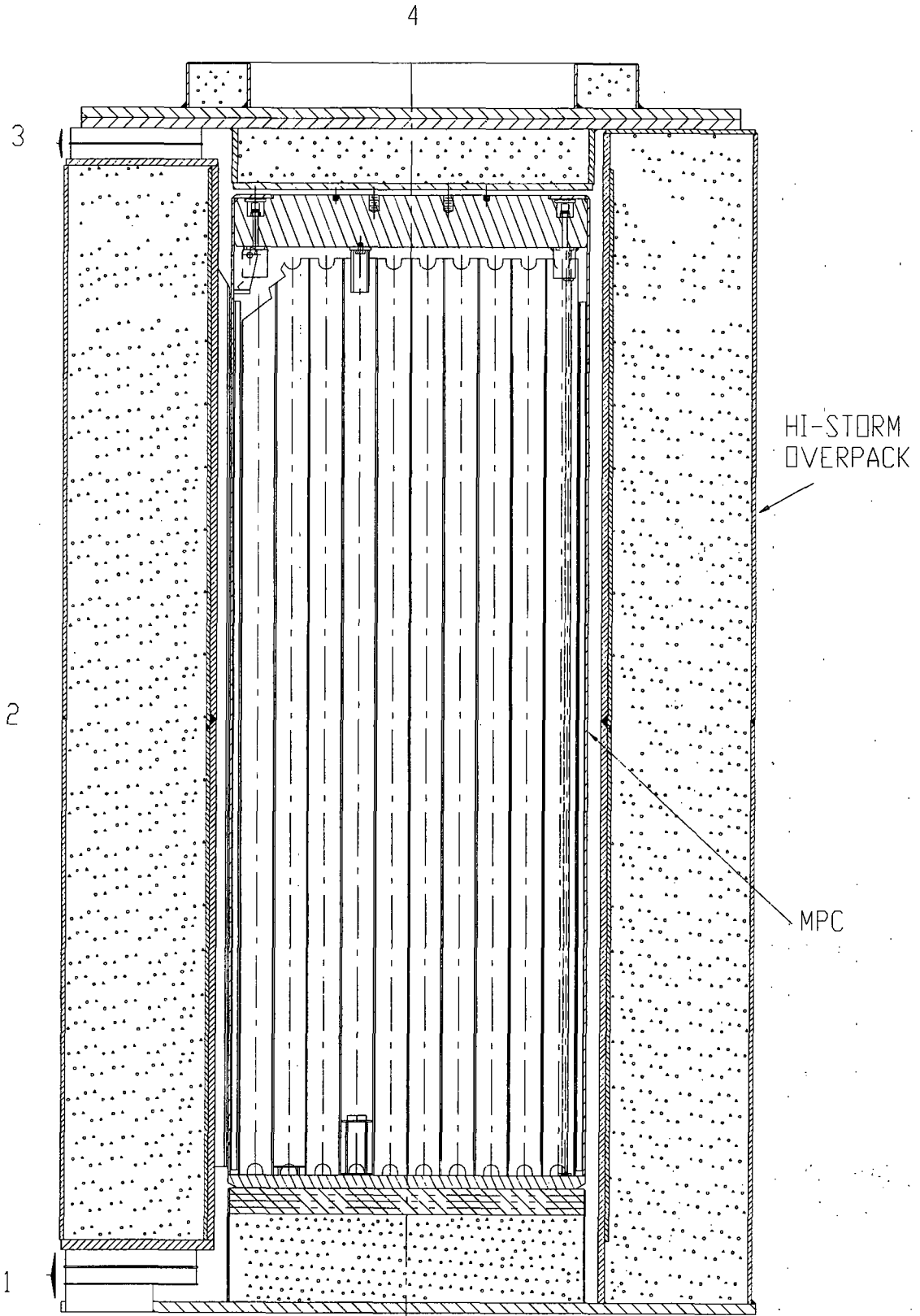


FIGURE 5.1.1; CROSS SECTION ELEVATION VIEW OF HI-STORM 100 OVERPACK WITH DOSE POINT LOCATION

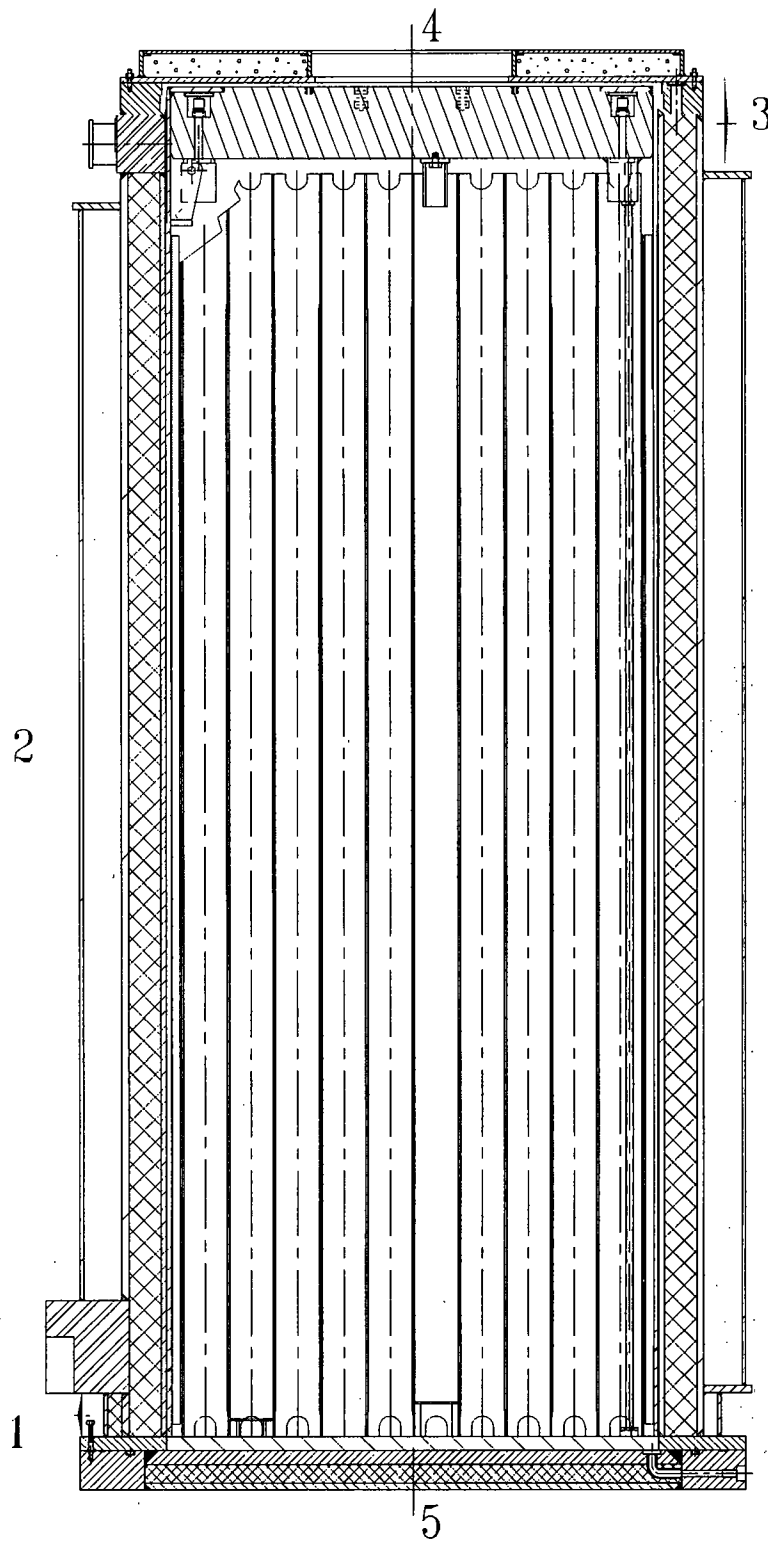


FIGURE 5.1.2; CROSS SECTION ELEVATION VIEW OF 125 TON HI-TRAC TRANSFER CASK WITH DOSE POINT LOCATIONS

REPORT HI-2002444

REVISION 0

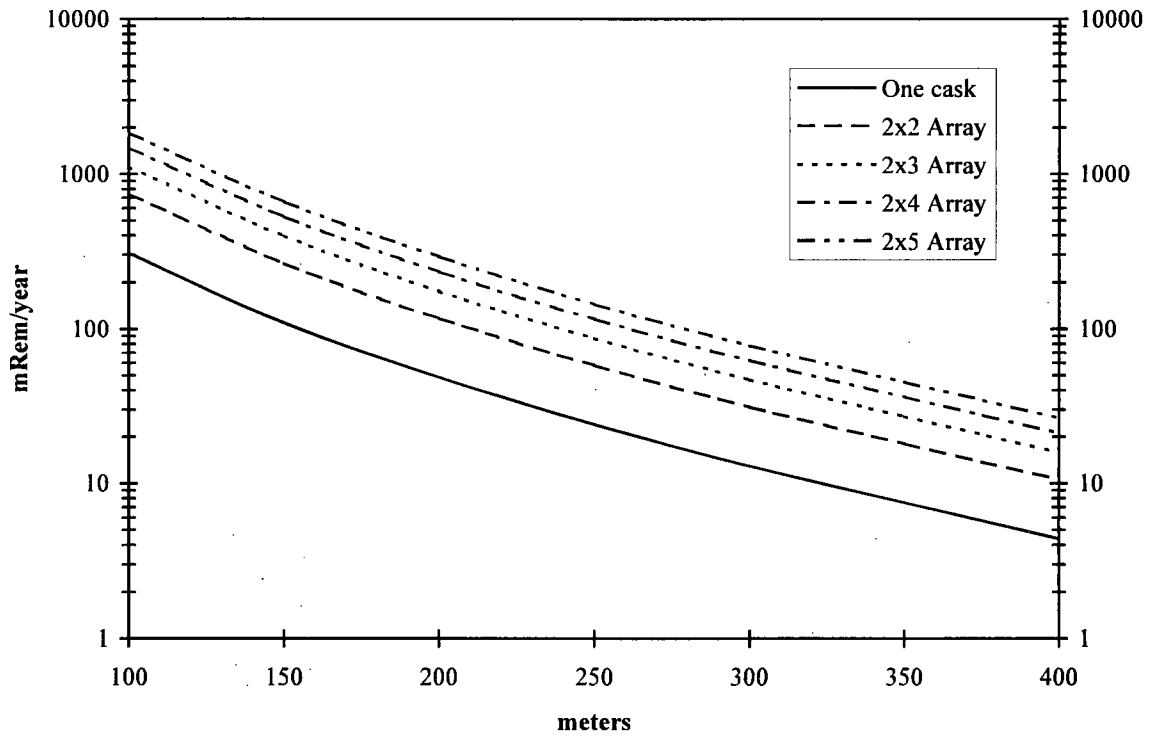


FIGURE 5.1.3; ANNUAL DOSE VERSUS DISTANCE FOR VARIOUS CONFIGURATIONS OF THE MPC-24 FOR 47,500 MWD/MTU AND 3-YEAR COOLING (8760 HOUR OCCUPANCY ASSUMED)

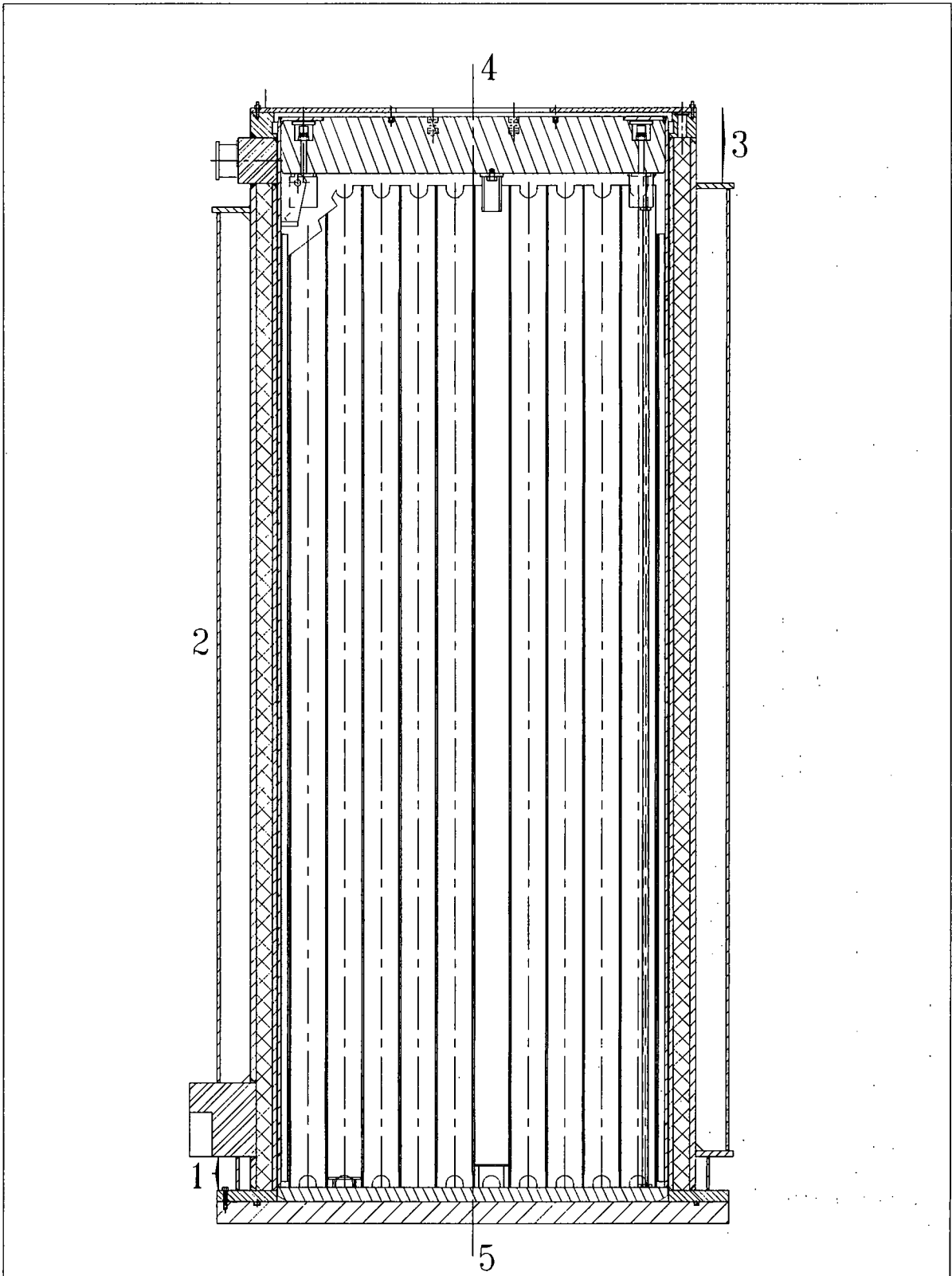


FIGURE 5.1.4; CROSS SECTION ELEVATION VIEW OF 100 TON HI-TRAC TRANSFER CASK (WITH POOL LID) WITH DOSE POINT LOCATIONS

REPORT HI-2002444

REVISION 0

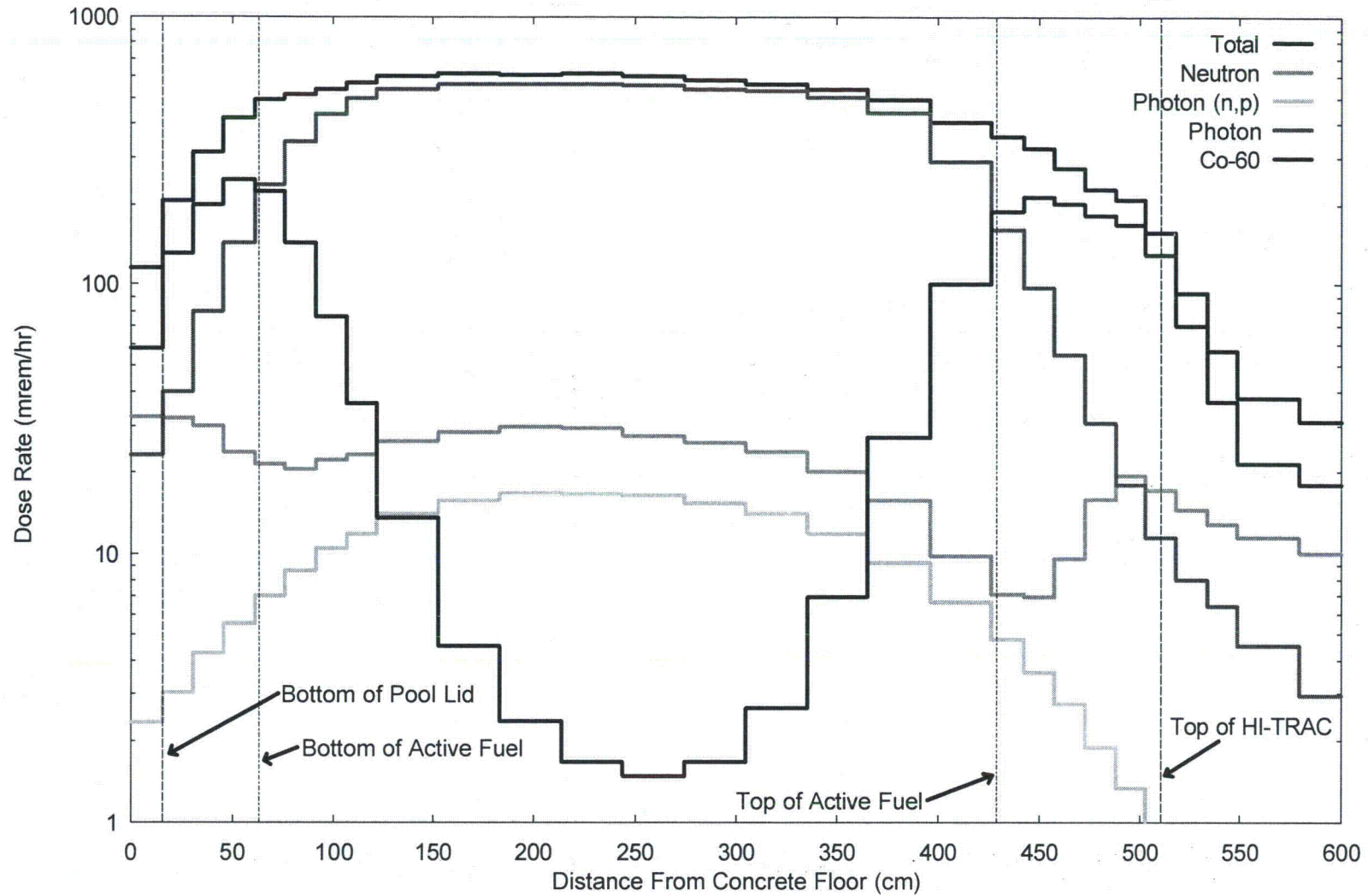


FIGURE 5.1.5; DOSE RATE 1-FOOT FROM THE SIDE OF THE 100-TON HI-TRAC TRANSFER CASK WITH THE MPC-24 FOR 35,000 MWD/MTU AND 5-YEAR COOLING

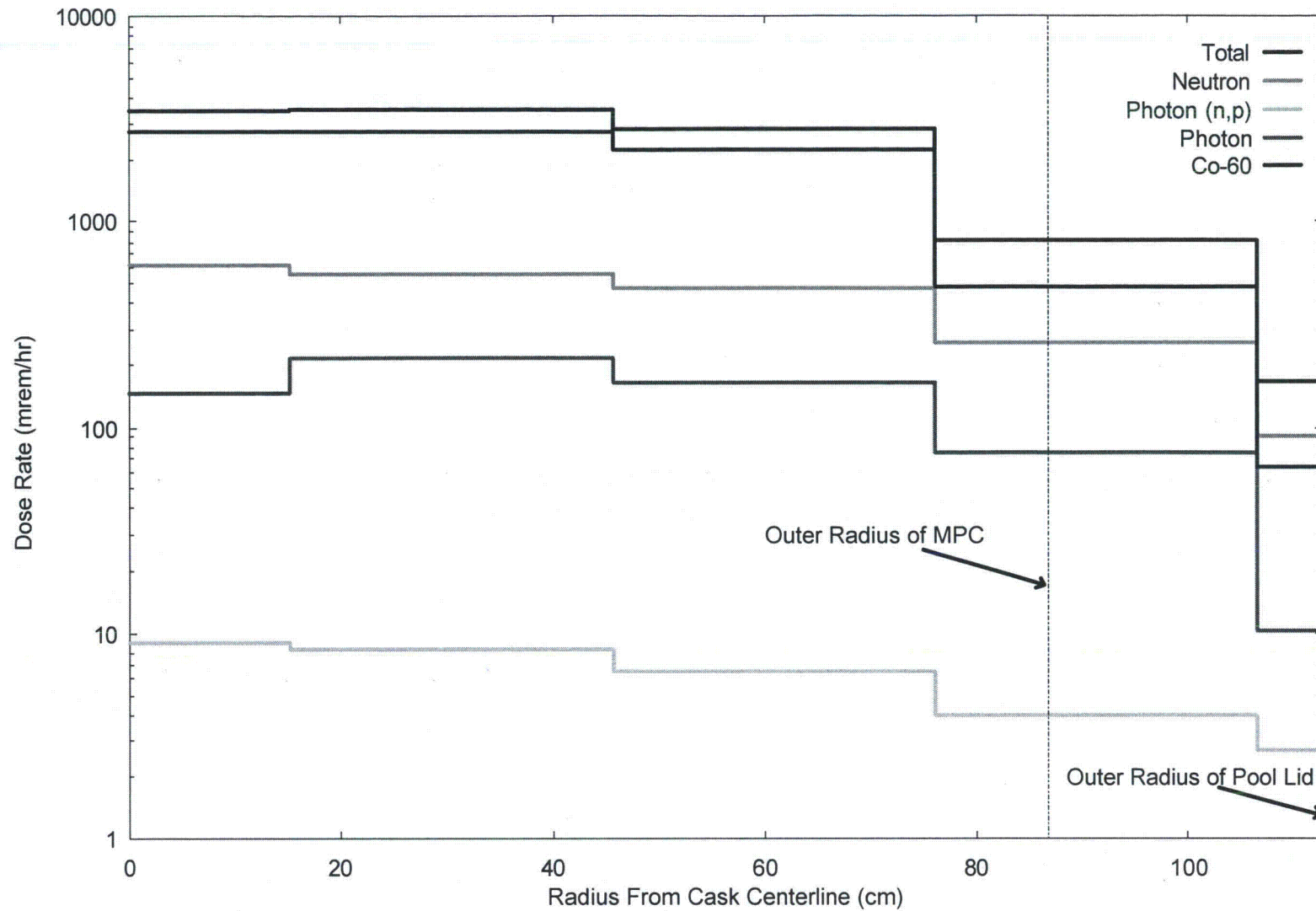


FIGURE 5.1.6; DOSE RATE ON THE SURFACE OF THE POOL LID ON THE 100-TON HI-TRAC TRANSFER CASK WITH THE MPC-24 FOR 35,000 MWD/MTU AND 5-YEAR COOLING

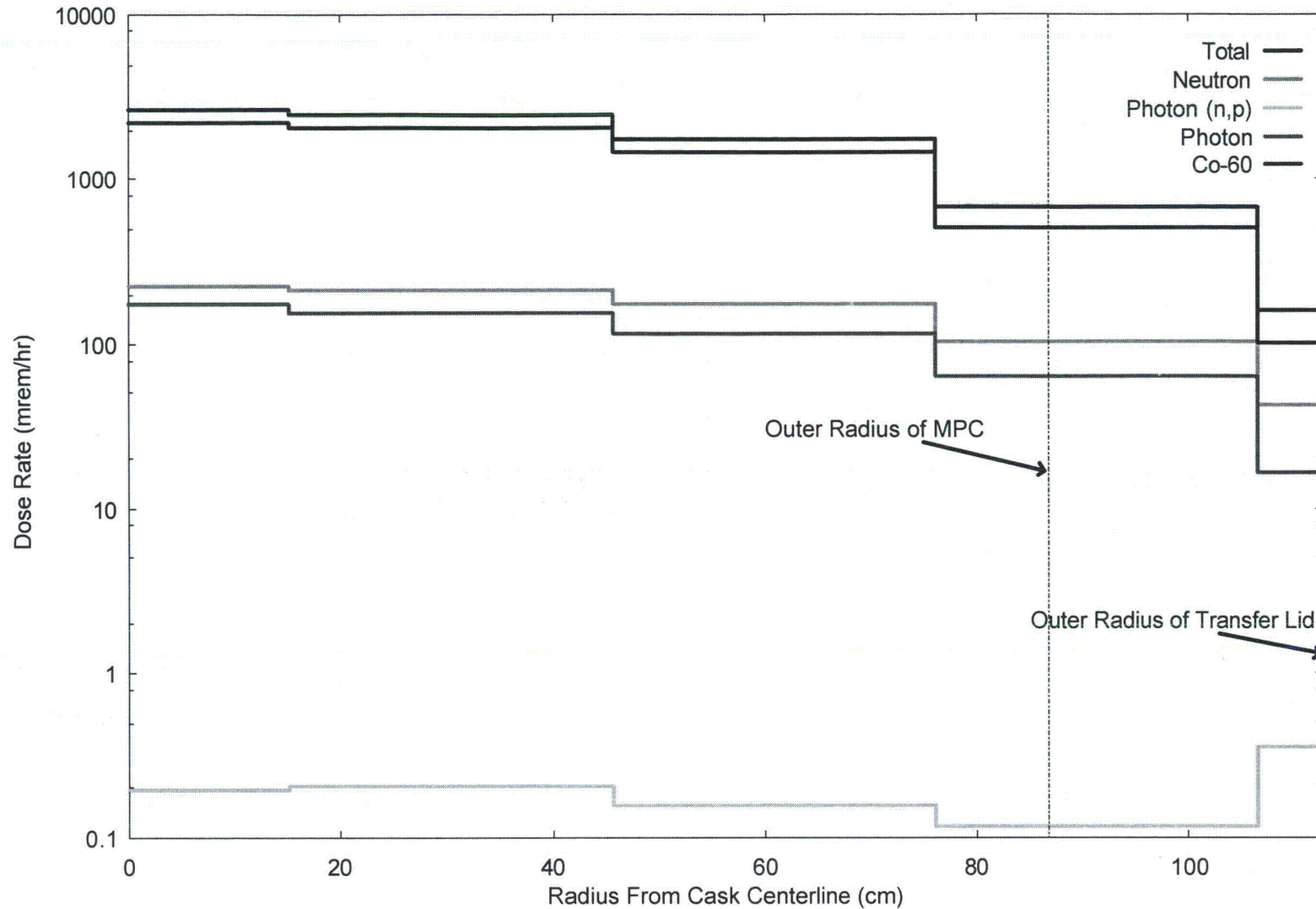


FIGURE 5.1.7; DOSE RATE 1-FOOT FROM THE BOTTOM OF TRANSFER LID ON THE 100-TON HI-TRAC TRANSFER CASK WITH THE MPC-24 FOR 35,000 MWD/MTU AND 5-YEAR COOLING

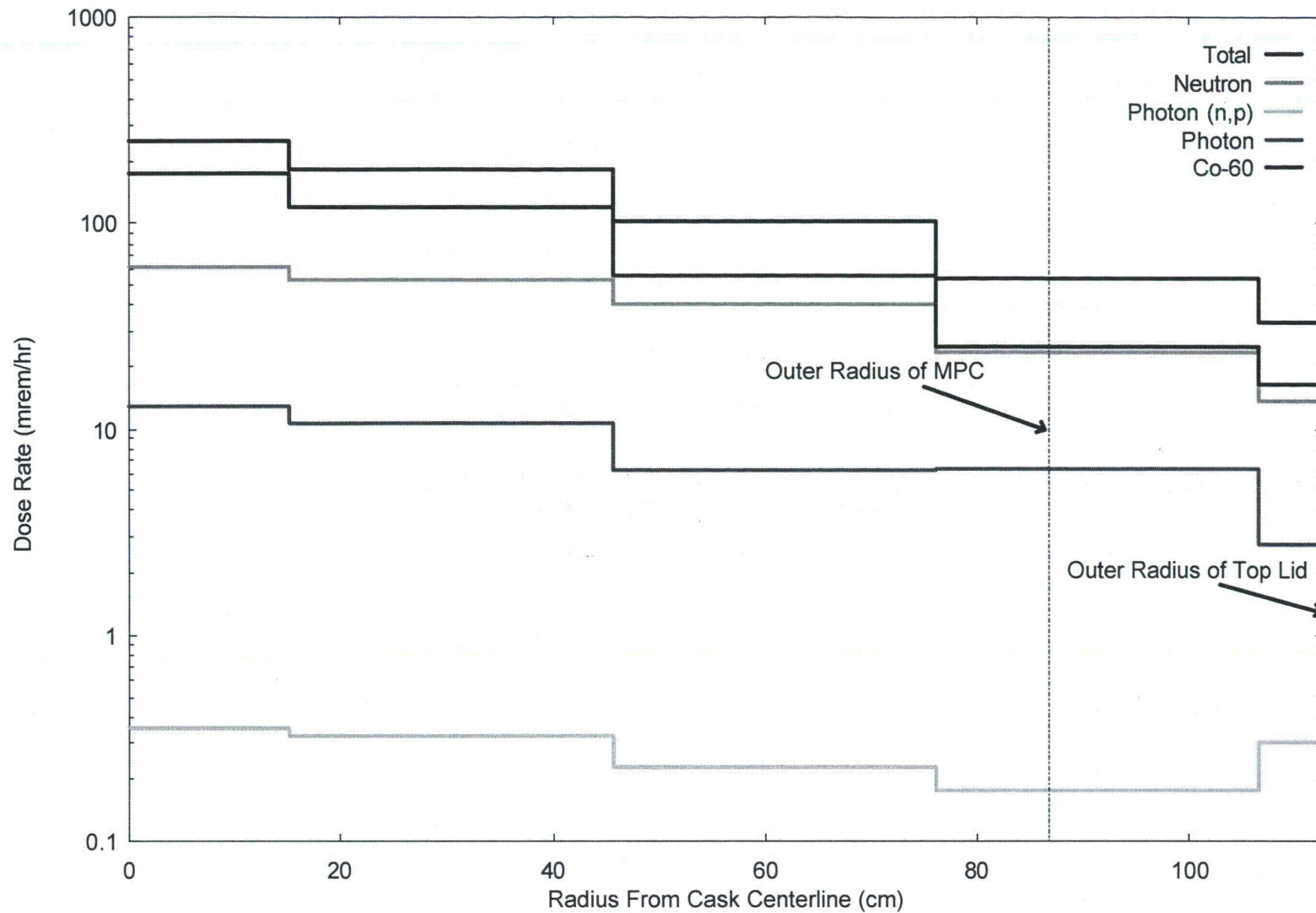


FIGURE 5.1.8; DOSE RATE 1-FOOT FROM THE TOP OF TOP LID ON THE 100-TON HI-TRAC TRANSFER CASK WITH THE MPC-24 FOR 35,000 MWD/MTU AND 5-YEAR COOLING

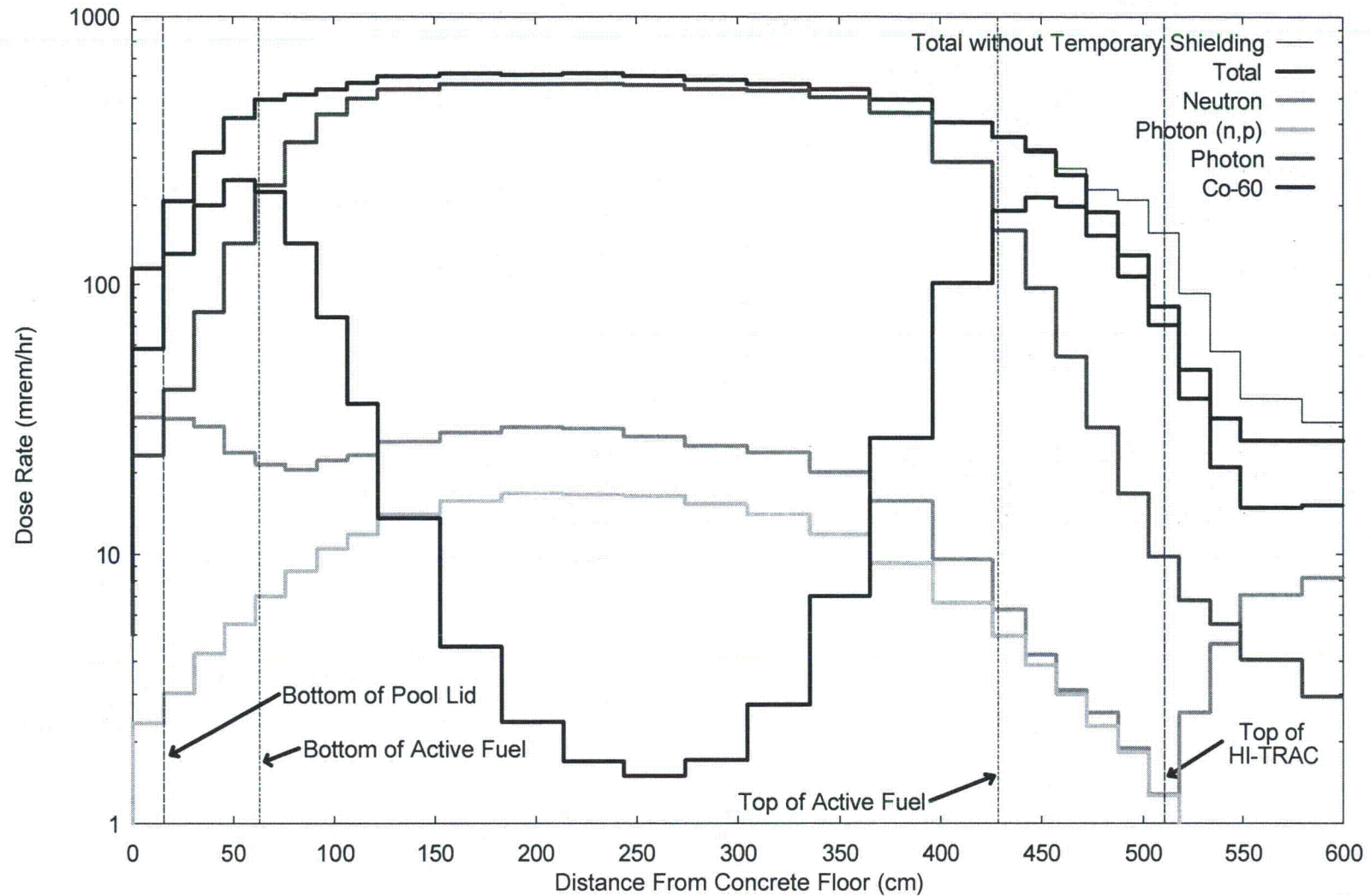


FIGURE 5.1.9; DOSE RATE 1-FOOT FROM THE SIDE OF THE 100-TON HI-TRAC TRANSFER CASK WITH TEMPORARY SHIELDING INSTALLED, WITH THE MPC-24 FOR 35,000 MWD/MTU AND 5-YEAR COOLING (TOTAL DOSE WITHOUT TEMPORARY SHIELDING SHOWN FOR COMPARISON)

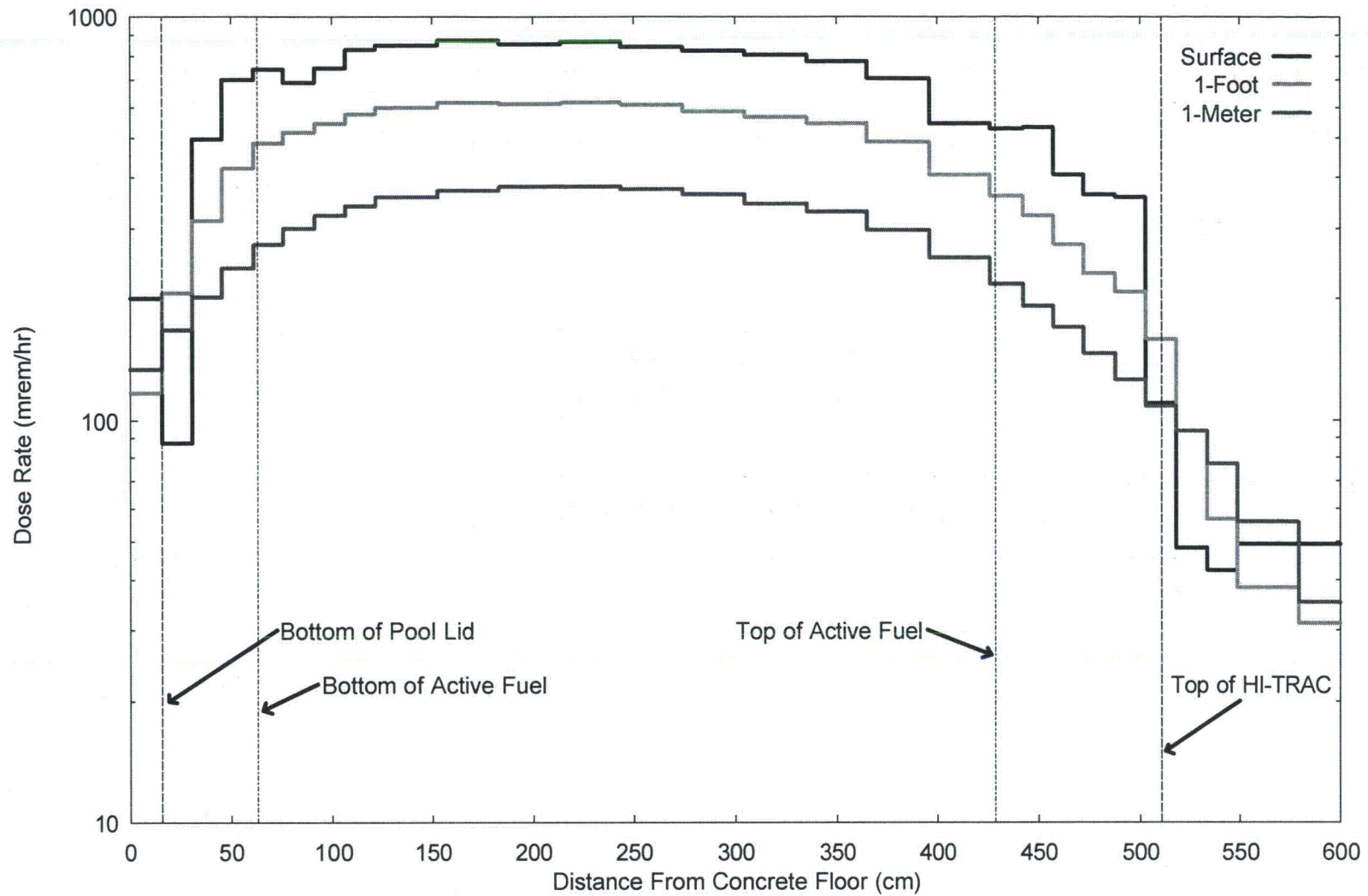


FIGURE 5.1.10; DOSE RATE AT VARIOUS DISTANCES FROM THE SIDE OF THE 100-TON HI-TRAC TRANSFER CASK WITH THE MPC-24 FOR 35,000 MWD/MTU AND 5-YEAR COOLING

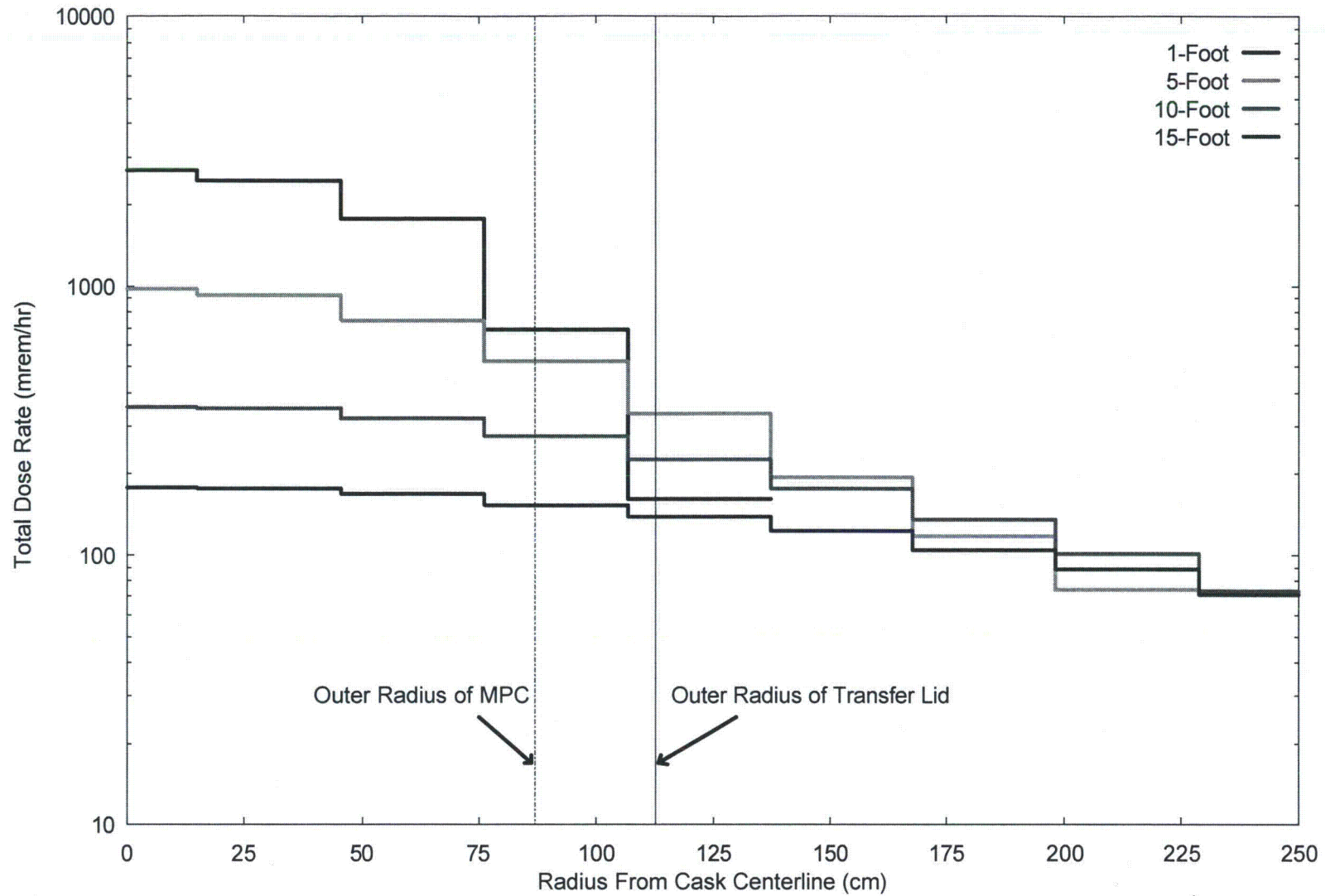


FIGURE 5.1.11; DOSE RATE AT VARIOUS DISTANCES FROM THE BOTTOM OF TRANSFER LID ON THE 100-TON HI-TRAC TRANSFER CASK WITH THE MPC-24 FOR 35,000 MWD/MTU AND 5-YEAR COOLING

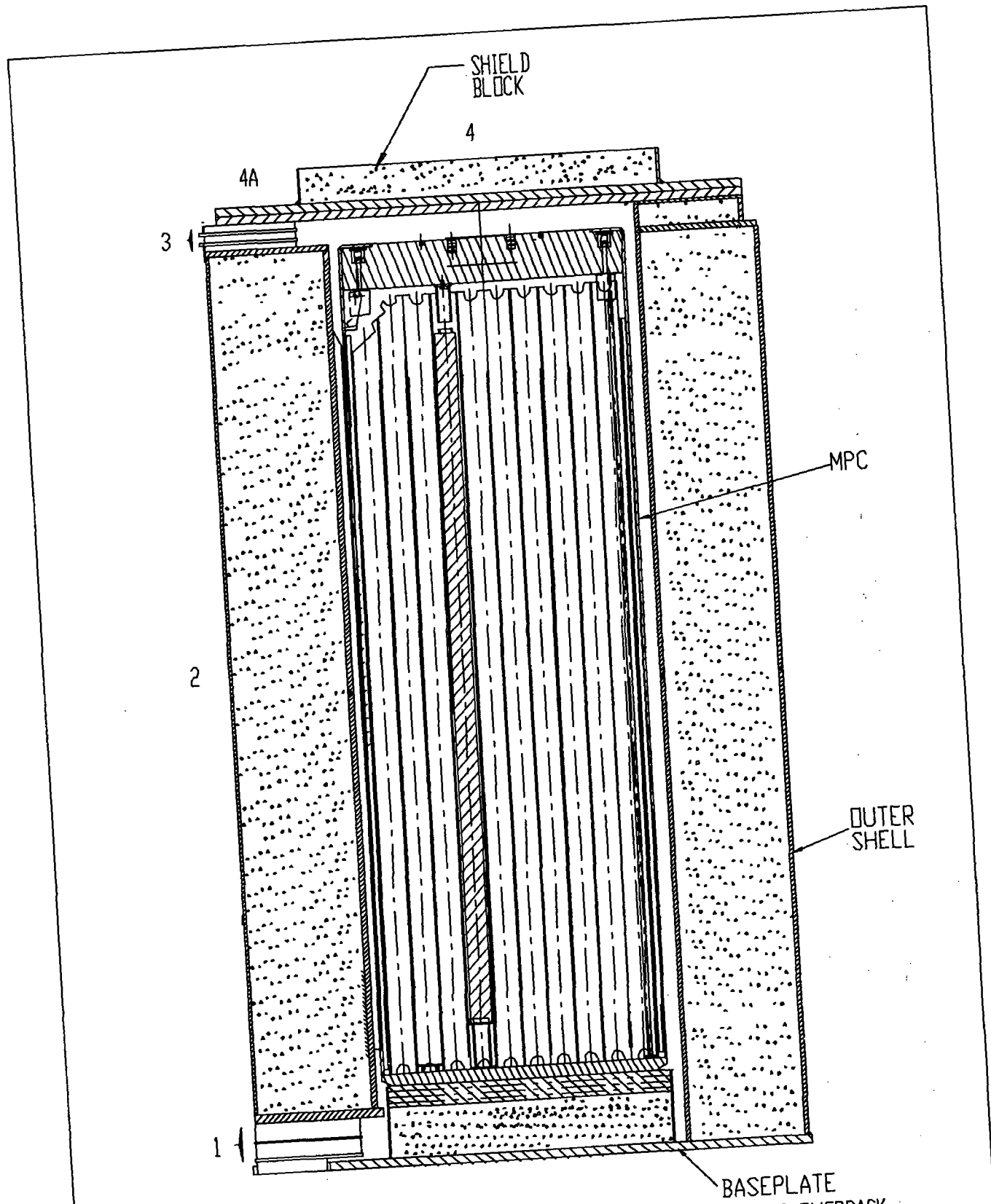


FIGURE 5.1.12; CROSS SECTION ELEVATION VIEW OF THE HI-STORM 100S OVERPACK WITH DOSE POINT LOCATION

REVISION 1

REPORT HI-2002444

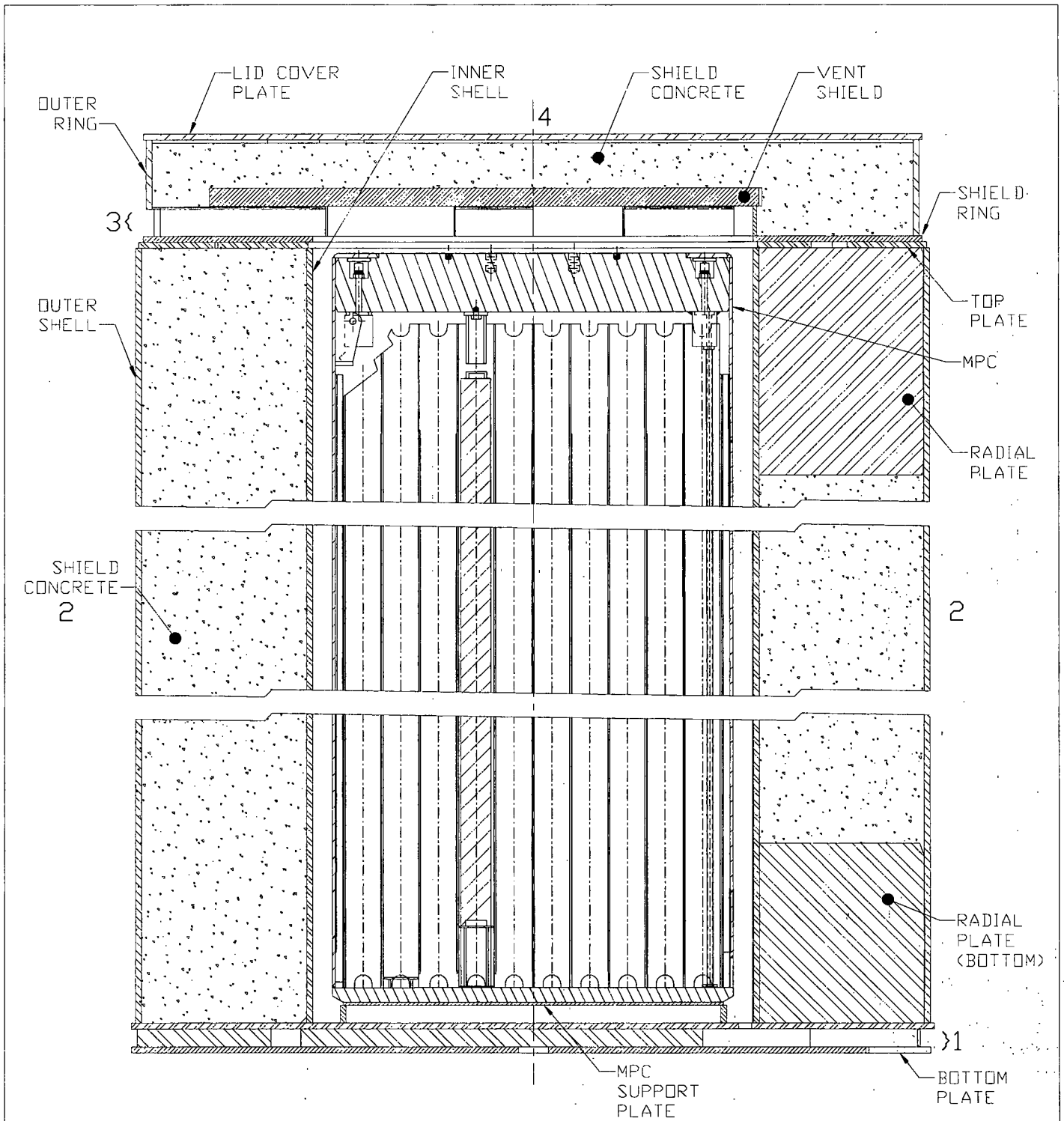


FIGURE 5.1.13; HI-STORM 100S VERSION B OVERPACK CROSS SECTIONAL ELEVATION VIEW WITH DOSE POINT LOCATION

5.2 SOURCE SPECIFICATION

The neutron and gamma source terms, decay heat values, and quantities of radionuclides available for release were calculated with the SAS2H and ORIGEN-S modules of the SCALE 4.3 system [5.1.2, 5.1.3]. SAS2H has been extensively compared to experimental isotopic validations and decay heat measurements. References [5.2.8] through [5.2.12] and [5.2.15] present isotopic comparisons for PWR and BWR fuels for burnups ranging to 47 GWD/MTU and reference [5.2.13] presents results for BWR measurements to a burnup of 57 GWD/MTU. A comparison of calculated and measured decay heats is presented in reference [5.2.14]. All of these studies indicate good agreement between SAS2H and measured data. Additional comparisons of calculated values and measured data are being performed by various institutions for high burnup PWR and BWR fuel. These new results, when published, are expected to further confirm the validity of SAS2H for the analysis of PWR and BWR fuel.

Sample input files for SAS2H and ORIGEN-S are provided in Appendices 5.A and 5.B, respectively. The gamma source term is actually comprised of three distinct sources. The first is a gamma source term from the active fuel region due to decay of fission products. The second source term is from ^{60}Co activity of the steel structural material in the fuel element above and below the active fuel region. The third source is from (n, γ) reactions described below.

A description of the design basis zircaloy clad fuel for the source term calculations is provided in Table 5.2.1. The PWR fuel assembly described is the assembly that produces the highest neutron and gamma sources and the highest decay heat load for a given burnup and cooling time from the following fuel assembly classes listed in Table 2.1.1: B&W 15x15, B&W 17x17, CE 14x14, CE 16x16, WE 14x14, WE 15x15, WE 17x17, St. Lucie, and Ft. Calhoun. The BWR fuel assembly described is the assembly that produces the highest neutron and gamma sources and the highest decay heat load for a given burnup and cooling time from the following fuel assembly classes listed in Table 2.1.2: GE BWR/2-3, GE BWR/4-6, Humboldt Bay 7x7, and Dresden 1 8x8. Multiple SAS2H and ORIGEN-S calculations were performed to confirm that the B&W 15x15 and the GE 7x7, which have the highest UO_2 mass, bound all other PWR and BWR fuel assemblies, respectively. Section 5.2.5 discusses, in detail, the determination of the design basis fuel assemblies.

The design basis Humboldt Bay and Dresden 1 6x6 fuel assembly is described in Table 5.2.2. The fuel assembly type listed produces the highest total neutron and gamma sources from the fuel assemblies at Dresden 1 and Humboldt Bay. Table 5.2.21 provides a description of the design basis Dresden 1 MOX fuel assembly used in this analysis. The design basis 6x6 and MOX fuel assemblies which are smaller than the GE 7x7, are assumed to have the same hardware characteristics as the GE 7x7. This is conservative because the larger hardware mass of the GE 7x7 results in a larger ^{60}Co activity.

HOLTEC INTERNATIONAL COPYRIGHTED MATERIAL

HI-STORM FSAR
REPORT HI-2002444

Rev. 12

5.2-1

The design basis stainless steel clad fuel assembly for the Indian Point 1, Haddam Neck, and San Onofre 1 assembly classes is described in Table 5.2.3. This table also describes the design basis stainless steel clad LaCrosse fuel assembly.

The design basis assemblies mentioned above are the design basis assemblies for both intact and damaged fuel and fuel debris for their respective array classes. Analyses of damaged fuel are presented in Section 5.4.2.

In performing the SAS2H and ORIGEN-S calculations, a single full power cycle was used to achieve the desired burnup. This assumption, in conjunction with the above-average specific powers listed in Tables 5.2.1, 5.2.2, 5.2.3, and 5.2.21 resulted in conservative source term calculations.

Sections 5.2.1 and 5.2.2 describe the calculation of gamma and neutron source terms for zircaloy clad fuel while Section 5.2.3 discusses the calculation of the gamma and neutron source terms for the stainless steel clad fuel.

5.2.1 Gamma Source

Tables 5.2.4 through 5.2.6 provide the gamma source in MeV/s and photons/s as calculated with SAS2H and ORIGEN-S for the design basis zircaloy clad fuels at varying burnups and cooling times. Tables 5.2.7 and 5.2.22 provides the gamma source in MeV/s and photons/s for the design basis 6x6 and MOX fuel, respectively.

Specific analysis for the HI-STORM 100 System, which includes the HI-STORM storage overpacks and the HI-TRAC transfer casks, was performed to determine the dose contribution from gammas as a function of energy. This analysis considered dose locations external to the 100-ton HI-TRAC transfer cask and the HI-STORM 100 overpack and vents. The results of this analysis have revealed that, due to the magnitude of the gamma source at lower energies, gammas with energies as low as 0.45 MeV must be included in the shielding analysis. The effect of gammas with energies above 3.0 MeV, on the other hand, was found to be insignificant (less than 1% of the total gamma dose at all high dose locations). This is due to the fact that the source of gammas in this range (i.e., above 3.0 MeV) is extremely low (less than 1% of the total source). Therefore, all gammas with energies in the range of 0.45 to 3.0 MeV are included in the shielding calculations. Dose rate contributions from above and below this range were evaluated and found to be negligible. Photons with energies below 0.45 MeV are too weak to penetrate the HI-STORM overpack or HI-TRAC, and photons with energies above 3.0 MeV are too few to contribute significantly to the external dose.

The primary source of activity in the non-fuel regions of an assembly arises from the activation of ^{59}Co to ^{60}Co . The primary source of ^{59}Co in a fuel assembly is impurities in the steel structural material above and below the fuel. The zircaloy in these regions is neglected since it does not have a significant ^{59}Co impurity level. Reference [5.2.2] indicates that the impurity level in steel is 800 ppm or 0.8 gm/kg. Conservatively, the impurity level of ^{59}Co was assumed to be 1000

HOLTEC INTERNATIONAL COPYRIGHTED MATERIAL

ppm or 1.0 gm/kg. Therefore, Inconel and stainless steel in the non-fuel regions are both conservatively assumed to have the same 1.0 gm/kg impurity level.

Holtec International has gathered information from utilities and vendors which shows that the 1.0 gm/kg impurity level is very conservative for fuel which has been manufactured since the mid-to-late 1980s after the implementation of an industry wide cobalt reduction program. The typical Cobalt-59 impurity level for fuel since the late 1980s is less than 0.5 gm/kg. Based on this, fuel with a short cooling time, 5 to 9 years, would have a Cobalt-59 impurity level less than 0.5 gm/kg. Therefore, the use of a bounding Cobalt-59 impurity level of 1.0 gm/kg is very conservative, particularly for recently manufactured assemblies. Analysis in Reference [5.2.3] indicates that the cobalt impurity in steel and inconel for fuel manufactured in the 1970s ranged from approximately 0.2 gm/kg to 2.2 gm/kg. However, older fuel manufactured with higher cobalt impurity levels will also have a corresponding longer cooling time and therefore will be bounded by the analysis presented in this chapter. As confirmation of this statement, Appendix D presents a comparison of the dose rates around the 100-ton HI-TRAC and the HI-STORM with the MPC-24 for a short cooling time (5 years) using the 1.0 gm/kg mentioned above and for a long cooling time (9 years) using a higher cobalt impurity level of 4.7 gm/kg for inconel. These results confirm that the dose rates for the longer cooling time with the higher impurity level are essentially equivalent to (within 11%) or bounded by the dose rates for the shorter cooling time with the lower impurity level. Therefore, the analysis in this chapter is conservative.

Some of the PWR fuel assembly designs (B&W and WE 15x15) utilized inconel in-core grid spacers while other PWR fuel designs use zircaloy in-core grid spacers. In the mid 1980s, the fuel assembly designs using inconel in-core grid spacers were altered to use zircaloy in-core grid spacers. Since both designs may be loaded into the HI-STORM 100 system, the gamma source for the PWR zircaloy clad fuel assembly includes the activation of the in-core grid spacers. Although BWR assembly grid spacers are zircaloy, some assembly designs have inconel springs in conjunction with the grid spacers. The gamma source for the BWR zircaloy clad fuel assembly includes the activation of these springs associated with the grid spacers.

The non-fuel data listed in Table 5.2.1 were taken from References [5.2.2], [5.2.4], and [5.2.5]. As stated above, a Cobalt-59 impurity level of 1 gm/kg (0.1 wt%) was used for both inconel and stainless steel. Therefore, there is little distinction between stainless steel and inconel in the source term generation and since the shielding characteristics are similar, stainless steel was used in the MCNP calculations instead of inconel. The BWR masses are for an 8x8 fuel assembly. These masses are also appropriate for the 7x7 assembly since the masses of the non-fuel hardware from a 7x7 and an 8x8 are approximately the same. The masses listed are those of the steel components. The zircaloy in these regions was not included because zircaloy does not produce significant activation. The masses are larger than most other fuel assemblies from other manufacturers. This, in combination with the conservative ⁵⁹Co impurity level and the use of conservative flux weighting fractions (discussed below) results in an over-prediction of the non-fuel hardware source that bounds all fuel for which storage is requested.

The masses in Table 5.2.1 were used to calculate a ^{59}Co impurity level in the fuel assembly material. The grams of impurity were then used in ORIGEN-S to calculate a ^{60}Co activity level for the desired burnup and decay time. The methodology used to determine the activation level was developed from Reference [5.2.3] and is described here.

1. The activity of the ^{60}Co is calculated using ORIGEN-S. The flux used in the calculation was the in-core fuel region flux at full power.
2. The activity calculated in Step 1 for the region of interest was modified by the appropriate scaling factors listed in Table 5.2.10. These scaling factors were taken from Reference [5.2.3].

Tables 5.2.11 through 5.2.13 provide the ^{60}Co activity utilized in the shielding calculations for the non-fuel regions of the assemblies in the MPC-32, MPC-24, and the MPC-68 for varying burnup and cooling times. The design basis 6x6 and MOX fuel assemblies are conservatively assumed to have the same ^{60}Co source strength as the BWR design basis fuel. This is a conservative assumption as the design basis 6x6 fuel and MOX fuel assemblies are limited to a significantly lower burnup and longer cooling time than the design basis fuel.

In addition to the two sources already mentioned, a third source arises from (n,γ) reactions in the material of the MPC and the overpack. This source of photons is properly accounted for in MCNP when a neutron calculation is performed in a coupled neutron-gamma mode.

There is some uncertainty associated with the ORIGEN-S calculations due to uncertainty in the physics data (e.g. cross sections, decay constants, etc.) and the modeling techniques. References [5.2.9], [5.2.10], and [5.2.15] perform comparisons between calculations and experimental isotopic measurement data. These comparisons indicate that calculated to measured ratios for Cs-134 and Eu-154, two of the major contributors to the gamma source, range from 0.79 to 1.009 and 0.79 to 0.98, respectively. These values provide representative insight into the entire range of possible error in the source term calculations. However, any non-conservatism associated with the uncertainty in the source term calculations is offset by the conservative nature of the source term and shielding calculations performed in this chapter, and therefore no adjustments were made to the calculated values.

5.2.2 Neutron Source

It is well known that the neutron source strength increases as enrichment decreases, for a constant burnup and decay time. This is due to the increase in Pu content in the fuel, which increases the inventory of other transuranium nuclides such as Cm. The gamma source also varies with enrichment, although only slightly. Because of this effect and in order to obtain conservative source terms, low initial fuel enrichments were chosen for the BWR and PWR design basis fuel assemblies. The enrichments are appropriately varied as a function of burnup. Table 5.2.24 presents the ^{235}U initial enrichments for various burnup ranges from 20,000 - 75,000

MWD/MTU for PWR and 20,000 - 70,000 MWD/MTU for BWR zircaloy clad fuel. These enrichments are based on References [5.2.6] and [5.2.7]. Table 8 of reference [5.2.6] presents average enrichments for burnup ranges. The initial enrichments chosen in Table 5.2.24, for burnups up to 50,000 MWD/MTU, are approximately the average enrichments from Table 8 of reference [5.2.6] for the burnup range that is 5,000 MWD/MTU less than the ranges listed in Table 5.2.24. These enrichments are below the enrichments typically required to achieve the burnups that were analyzed. For burnups greater than 50,000 MWD/MTU, the data on historical and projected burnups available in the LWR Quantities Database in reference [5.2.7] and some additional data from nuclear plants was reviewed and conservatively low enrichments were chosen for each burnup range above 50,000 MWD/MTU.

Inherent to this approach of selecting minimum enrichments that bound the vast majority of discharged fuel is the fact that a small number of atypical assemblies will not be bounded. However, these atypical assemblies are very few in number (as evidenced by the referenced discharge data), and thus, it is unlikely that a single cask would contain several of these outlying assemblies. Further, because the approach is based on using minimum enrichments for given burnup ranges, any atypical assemblies that may exist are expected to have enrichments that are very near to the minimum enrichments used in the analysis. Therefore, the result is an insignificant effect on the calculated dose rates. Consequently, the minimum enrichment values used in the shielding analysis are adequate to bound the fuel authorized by the limits in Section 2.1.9 for loading in the HI-STORM system. Since the enrichment does affect the source term evaluation, it is recommended that the site-specific dose evaluation consider the enrichment for the fuel being stored.

The neutron source calculated for the design basis fuel assemblies for the MPC-24, MPC-32, and MPC-68 and the design basis 6x6 fuel are listed in Tables 5.2.15 through 5.2.18 in neutrons/s for varying burnup and cooling times. Table 5.2.23 provides the neutron source in neutrons/sec for the design basis MOX fuel assembly. ^{244}Cm accounts for approximately 92-97% of the total number of neutrons produced. Alpha,n reactions in isotopes other than ^{244}Cm account for approximately 0.3-2% of the neutrons produced while spontaneous fission in isotopes other than ^{244}Cm account for approximately 2-8% of the neutrons produced within the UO_2 fuel. In addition, any neutrons generated from subcritical multiplication, (n,2n) or similar reactions are properly accounted for in the MCNP calculation.

There is some uncertainty associated with the ORIGEN-S calculations due to uncertainty in the physics data (e.g. cross sections, decay constants, etc.) and the modeling techniques. References [5.2.9], [5.2.10], and [5.2.15] perform comparisons between calculations and experimental isotopic measurement data. These comparisons indicate that calculated to measured ratios for Cm-244 ranges from 0.81 to 0.95. These values provide representative insight into the entire range of possible error in the source term calculations. However, any non-conservatism associated with the uncertainty in the source term calculations is offset by the conservative nature of the source term and shielding calculations performed in this chapter, and therefore no adjustments were made to the calculated values.

5.2.3 Stainless Steel Clad Fuel Source

Table 5.2.3 lists the characteristics of the design basis stainless steel clad fuel. The fuel characteristics listed in this table are the input parameters that were used in the shielding calculations described in this chapter. The active fuel length listed in Table 5.2.3 is actually longer than the true active fuel length of 122 inches for the WE 15x15 and 83 inches for the LaCrosse 10x10. Since the true active fuel length is shorter than the design basis zircaloy clad active fuel length, it would be incorrect to calculate source terms for the stainless steel fuel using the correct fuel length and compare them directly to the zircaloy clad fuel source terms because this does not reflect the potential change in dose rates. As an example, if it is assumed that the source strength for both the stainless steel and zircaloy fuel is 144 neutrons/s and that the active fuel lengths of the stainless steel fuel and zircaloy fuel are 83 inches and 144 inches, respectively; the source strengths per inch of active fuel would be different for the two fuel types, 1.73 neutrons/s/inch and 1 neutron/s/inch for the stainless steel and zircaloy fuel, respectively. The result would be a higher neutron dose rate at the center of the cask with the stainless steel fuel than with the zircaloy clad fuel; a conclusion that would be overlooked by just comparing the source terms. This is an important consideration because the stainless steel clad fuel differs from the zircaloy clad in one important aspect: the stainless steel cladding will contain a significant photon source from Cobalt-60 which will be absent from the zircaloy clad fuel.

In order to eliminate the potential confusion when comparing source terms, the stainless steel clad fuel source terms were calculated with the same active fuel length as the design basis zircaloy clad fuel. Reference [5.2.2] indicates that the Cobalt-59 impurity level in steel is 800 ppm or 0.8 gm/kg. This impurity level was used for the stainless steel cladding in the source term calculations. It is assumed that the end fitting masses of the stainless steel clad fuel are the same as the end fitting masses of the zircaloy clad fuel. Therefore, separate source terms are not provided for the end fittings of the stainless steel fuel.

Tables 5.2.8, 5.2.9, 5.2.19, and 5.2.20 list the gamma and neutron source strengths for the design basis stainless steel clad fuel. It is obvious from these source terms that the neutron source strength for the stainless steel fuel is lower than for the zircaloy fuel. However, this is not true for all photon energy groups. The peak energy group is from 1.0 to 1.5 MeV, which results from the large Cobalt activation in the cladding. Since some of the source strengths are higher for the stainless steel fuel, Section 5.4.4 presents the dose rates at the center of the overpack for the stainless steel fuel. The center dose location is the only location of concern since the end fittings are assumed to be the same mass as the end fittings for the zircaloy clad fuel. In addition, the burnup is lower and the cooling time is longer for the stainless steel fuel compared to the zircaloy clad fuel.

5.2.4 Non-fuel Hardware

Burnable poison rod assemblies (BPRAs), thimble plug devices (TPDs), control rod assemblies (CRAs), and axial power shaping rods (APSRs) are permitted for storage in the HI-STORM 100

HOLTEC INTERNATIONAL COPYRIGHTED MATERIAL

System as an integral part of a PWR fuel assembly. BPRAs and TPDs may be stored in any fuel location while CRAs and APSRs are restricted as specified in Section 2.1.9.

5.2.4.1 BPRAs and TPDs

Burnable poison rod assemblies (BPRAs) (including wet annular burnable absorbers) and thimble plug devices (TPD) (including orifice rod assemblies, guide tube plugs, and water displacement guide tube plugs) are an integral, yet removable, part of a large portion of PWR fuel. The TPDs are not used in all assemblies in a reactor core but are reused from cycle to cycle. Therefore, these devices can achieve very high burnups. In contrast, BPRAs are burned with a fuel assembly in core and are not reused. In fact, many BPRAs are removed after one or two cycles before the fuel assembly is discharged. Therefore, the achieved burnup for BPRAs is not significantly different than fuel assemblies. Vibration suppressor inserts are considered to be in the same category as BPRAs for the purposes of the analysis in this chapter since these devices have the same configuration (long non-absorbing thimbles which extend into the active fuel region) as a BPRAs without the burnable poison.

TPDs are made of stainless steel and contain a small amount of inconel. These devices extend down into the plenum region of the fuel assembly but do not extend into the active fuel region with the exception of the W 14x14 water displacement guide tube plugs. Since these devices are made of stainless steel, there is a significant amount of cobalt-60 produced during irradiation. This is the only significant radiation source from the activation of steel and inconel.

BPRAs are made of stainless steel in the region above the active fuel zone and may contain a small amount of inconel in this region. Within the active fuel zone the BPRAs may contain 2-24 rodlets which are burnable absorbers clad in either zircaloy or stainless steel. The stainless steel clad BPRAs create a significant radiation source (Co-60) while the zircaloy clad BPRAs create a negligible radiation source. Therefore the stainless steel clad BPRAs are bounding.

SAS2H and ORIGEN-S were used to calculate a radiation source term for the TPDs and BPRAs. In the ORIGEN-S calculations the cobalt-59 impurity level was conservatively assumed to be 0.8 gm/kg for stainless steel and 4.7 gm/kg for inconel. These calculations were performed by irradiating the appropriate mass of steel and inconel using the flux calculated for the design basis B&W 15x15 fuel assembly. The mass of material in the regions above the active fuel zone was scaled by the appropriate scaling factors listed in Table 5.2.10 in order to account for the reduced flux levels above the fuel assembly. The total curies of cobalt were calculated for the TPDs and BPRAs as a function of burnup and cooling time. For burnups beyond 45,000 MWD/MTU, it was assumed, for the purpose of the calculation, that the burned fuel assembly was replaced with a fresh fuel assembly every 45,000 MWD/MTU. This was achieved in ORIGEN-S by resetting the flux levels and cross sections to the 0 MWD/MTU condition after every 45,000 MWD/MTU.

Since the HI-STORM 100 cask system is designed to store many varieties of PWR fuel, a bounding TPD and BPRAs had to be determined for the purposes of the analysis. This was accomplished by analyzing all of the BPRAs and TPDs (Westinghouse and B&W 14x14 through

HOLTEC INTERNATIONAL COPYRIGHTED MATERIAL

17x17) found in references [5.2.5] and [5.2.7] to determine the TPD and BPRA which produced the highest Cobalt-60 source term and decay heat for a specific burnup and cooling time. The bounding TPD was determined to be the Westinghouse 17x17 guide tube plug and the bounding BPRA was actually determined by combining the higher masses of the Westinghouse 17x17 and 15x15 BPRAs into a singly hypothetical BPRA. The masses of this TPD and BPRA are listed in Table 5.2.30. As mentioned above, reference [5.2.5] describes the Westinghouse 14x14 water displacement guide tube plug as having a steel portion which extends into the active fuel zone. This particular water displacement guide tube plug was analyzed and determined to be bounded by the design basis TPD and BPRA.

Once the bounding BPRA and TPD were determined, the allowable Co-60 source and decay heat from the BPRA and TPD were specified as: 50 curies Co-60 and 0.77 watts for each TPD and 895 curies Co-60 and 14.4 watts for each BPRA. Table 5.2.31 shows the curies of Co-60 that were calculated for BPRAs and TPDs in each region of the fuel assembly (e.g. incore, plenum, top). An allowable burnup and cooling time, separate from the fuel assemblies, is used for BPRAs and TPDs. These burnup and cooling times assure that the Cobalt-60 activity remains below the allowable levels specified above. It should be noted that at very high burnups, greater than 200,000 MWD/MTU the TPD Co-60 source actually decreases as the burnup continues to increase. This is due to a decrease in the Cobalt-60 production rate as the initial Cobalt-59 impurity is being depleted. Conservatively, a constant cooling time has been specified for burnups from 180,000 to 630,000 MWD/MTU for the TPDs.

Section 5.4.6 discusses the increase in the cask dose rates due to the insertion of BPRAs or TPDs into fuel assemblies.

5.2.4.2 CRAs and APSRs

Control rod assemblies (CRAs) (including control element assemblies and rod cluster control assemblies) and axial power shaping rod assemblies (APSRs) are an integral portion of a PWR fuel assembly. These devices are utilized for many years (upwards of 20 years) prior to discharge into the spent fuel pool. The manner in which the CRAs are utilized vary from plant to plant. Some utilities maintain the CRAs fully withdrawn during normal operation while others may operate with a bank of rods partially inserted (approximately 10%) during normal operation. Even when fully withdrawn, the ends of the CRAs are present in the upper portion of the fuel assembly since they are never fully removed from the fuel assembly during operation. The result of the different operating styles is a variation in the source term for the CRAs. In all cases, however, only the lower portion of the CRAs will be significantly activated. Therefore, when the CRAs are stored with the PWR fuel assembly, the activated portion of the CRAs will be in the lower portion of the cask. CRAs are fabricated of various materials. The cladding is typically stainless steel, although inconel has been used. The absorber can be a single material or a combination of materials. AgInCd is possibly the most common absorber although B₄C in aluminum is used, and hafnium has also been used. AgInCd produces a noticeable source term in the 0.3-1.0 MeV range due to the activation of Ag. The source term from the other absorbers is negligible, therefore the AgInCd CRAs are the bounding CRAs.

HOLTEC INTERNATIONAL COPYRIGHTED MATERIAL

APSRs are used to flatten the power distribution during normal operation and as a result these devices achieve a considerably higher activation than CRAs. There are two types of B&W stainless steel clad APSRs: gray and black. According to reference [5.2.5], the black APSRs have 36 inches of AgInCd as the absorber while the gray ones use 63 inches of inconel as the absorber. Because of the cobalt-60 source from the activation of inconel, the gray APSRs produce a higher source term than the black APSRs and therefore are the bounding APSR.

Since the level of activation of CRAs and APSRs can vary, the quantity that can be stored in an MPC is being limited. These devices are required to be stored in the locations as outlined in Section 2.1.9.

In order to determine the impact on the dose rates around the HI-STORM 100 System, source terms for the CRAs and APSRs were calculated using SAS2H and ORIGEN-S. In the ORIGEN-S calculations the cobalt-59 impurity level was conservatively assumed to be 0.8 gm/kg for stainless steel and 4.7 gm/kg for inconel. These calculations were performed by irradiating 1 kg of steel, inconel, and AgInCd using the flux calculated for the design basis B&W 15x15 fuel assembly. The total curies of cobalt for the steel and inconel and the 0.3-1.0 MeV source for the AgInCd were calculated as a function of burnup and cooling time to a maximum burnup of 630,000 MWD/MTU. For burnups beyond 45,000 MWD/MTU, it was assumed, for the purpose of the calculation, that the burned fuel assembly was replaced with a fresh fuel assembly every 45,000 MWD/MTU. This was achieved in ORIGEN-S by resetting the flux levels and cross sections to the 0 MWD/MTU condition after every 45,000 MWD/MTU. The sources were then scaled by the appropriate mass using the flux weighting factors for the different regions of the assembly to determine the final source term. Two different configurations were analyzed for both the CRAs and APSRs with an additional third configuration analyzed for the APSRs. The configurations, which are summarized below, are described in Tables 5.2.32 for the CRAs and Table 5.2.33 for the APSR. The masses of the materials listed in these tables were determined from a review of [5.2.5] with bounding values chosen. The masses listed in Tables 5.2.32 and 5.2.33 do not match exact values from [5.2.5] because the values in the reference were adjusted to the lengths shown in the tables.

Configuration 1: CRA and APSR

This configuration had the lower 15 inches of the CRA and APSR activated at full flux with two regions above the 15 inches activated at a reduced power level. This simulates a CRA or APSR which was operated at 10% insertion. The regions above the 15 inches reflect the upper portion of the fuel assembly.

Configuration 2: CRA and APSR

This configuration represents a fully removed CRA or APSR during normal core operations. The activated portion corresponds to the upper portion of a fuel assembly above the active fuel length with the appropriate flux weighting factors used.

Configuration 3: APSR

This configuration represents a fully inserted gray APSR during normal core operations. The region in full flux was assumed to be the 63 inches of the absorber.

Tables 5.2.34 and 5.2.35 present the source terms, including decay heat, that were calculated for the CRAs and APSRs respectively. The only significant source from the activation of in-conel or steel is Co-60 and the only significant source from the activation of AgInCd is from 0.3-1.0 MeV. The source terms for CRAs, Table 5.2.34, were calculated for a maximum burnup of 630,000 MWD/MTU and a minimum cooling time of 5 years. Because of the significant source term in APSRs that have seen extensive in-core operations, the source term in Table 5.2.35 was calculated to be a bounding source term for a variable burnup and cooling time as outlined in Section 2.1.9. The very larger Cobalt-60 activity in configuration 3 in Table 5.2.35 is due to the assumed Cobalt-59 impurity level of 4.7 gm/kg. If this impurity level were similar to the assumed value for steel, 0.8 gm/kg, this source would decrease by approximately a factor of 5.8.

Section 5.4.6 discusses the effect on dose rate of the insertion of APSRs into the inner four fuel assemblies in the MPC-24 and inner twelve fuel assemblies in the MPC-32, as well as the insertion of CRAs into the inner twelve fuel assemblies of the MPC-24 and MPC-32.

5.2.5 Choice of Design Basis Assembly

The analysis presented in this chapter was performed to bound the fuel assembly classes listed in Tables 2.1.1 and 2.1.2. In order to perform a bounding analysis, a design basis fuel assembly must be chosen. Therefore, a fuel assembly from each fuel class was analyzed and a comparison of the neutrons/sec, photons/sec, and thermal power (watts) was performed. The fuel assembly that produced the highest source for a specified burnup, cooling time, and enrichment was chosen as the design basis fuel assembly. A separate design basis assembly was chosen for the PWR MPCs (MPC-24 and MPC-32) and the BWR MPCs (MPC-68).

5.2.5.1 PWR Design Basis Assembly

Table 2.1.1 lists the PWR fuel assembly classes that were evaluated to determine the design basis PWR fuel assembly. Within each class, the fuel assembly with the highest UO₂ mass was analyzed. Since the variations of fuel assemblies within a class are very minor (pellet diameter, clad thickness, etc.), it is conservative to choose the assembly with the highest UO₂ mass. For a given class of assemblies, the one with the highest UO₂ mass will produce the highest radiation source because, for a given burnup (MWD/MTU) and enrichment, the highest UO₂ mass will have produced the most energy and therefore the most fission products.

Table 5.2.25 presents the characteristics of the fuel assemblies analyzed to determine the design basis zircaloy clad PWR fuel assembly. The corresponding fuel assembly array class from Section 2.1.9 is also listed in the table. The fuel assembly listed for each class is the assembly with the highest UO₂ mass. The St. Lucie and Ft. Calhoun classes are not present in Table 5.2.25. These assemblies are shorter versions of the CE 16x16 and CE 14x14 assembly classes,

HOLTEC INTERNATIONAL COPYRIGHTED MATERIAL

respectively. Therefore, these assemblies are bounded by the CE 16x16 and CE 14x14 classes and were not explicitly analyzed. Since the Indian Point 1, Haddam Neck, and San Onofre 1 classes are stainless steel clad fuel, these classes were analyzed separately and are discussed below. All fuel assemblies in Table 5.2.25 were analyzed at the same burnup and cooling time. The initial enrichment used in the analysis is consistent with Table 5.2.24. The results of the comparison are provided in Table 5.2.27. These results indicate that the B&W 15x15 fuel assembly has the highest radiation source term of the zircaloy clad fuel assembly classes considered in Table 2.1.1. This fuel assembly also has the highest UO_2 mass (see Table 5.2.25) which confirms that, for a given initial enrichment, burnup, and cooling time, the assembly with the highest UO_2 mass produces the highest radiation source term. The power/assembly values used in Table 5.2.25 were calculated by dividing 110% of the thermal power for commercial PWR reactors using that array class by the number of assemblies in the core. The higher thermal power, 110%, was used to account for potential power uprates. The power level used for the B&W15 is an additional 17% higher for consistency with previous revisions of the FSAR which also used this assembly as the design basis assembly.

The Haddam Neck and San Onofre 1 classes are shorter stainless steel clad versions of the WE 15x15 and WE 14x14 classes, respectively. Since these assemblies have stainless steel clad, they were analyzed separately as discussed in Section 5.2.3. Based on the results in Table 5.2.27, which show that the WE 15x15 assembly class has a higher source term than the WE 14x14 assembly class, the Haddam Neck, WE 15x15, fuel assembly was analyzed as the bounding PWR stainless steel clad fuel assembly. The Indian Point 1 fuel assembly is a unique 14x14 design with a smaller mass of fuel and clad than the WE14x14. Therefore, it is also bounded by the WE 15x15 stainless steel fuel assembly.

As discussed below in Section 5.2.5.3, the allowable burnup limits in Section 2.1.9 were calculated for different array classes rather than using the design basis assembly to calculate the allowable burnups for all array classes. As mentioned above, the design basis assembly has the highest neutron and gamma source term of the various array classes for the same burnup and cooling time. In order to account for the fact that different array classes have different allowable burnups for the same cooling time, burnups which bound the 14x14A array class were used with the design basis assembly for the analysis in this chapter because those burnups bound the burnups from all other PWR array classes. This approach assures that the calculated source terms and dose rates will be conservative.

5.2.5.2 BWR Design Basis Assembly

Table 2.1.2 lists the BWR fuel assembly classes that were evaluated to determine the design basis BWR fuel assembly. Since there are minor differences between the array types in the GE BWR/2-3 and GE BWR/4-6 assembly classes, these assembly classes were not considered individually but rather as a single class. Within that class, the array types, 7x7, 8x8, 9x9, and 10x10 were analyzed to determine the bounding BWR fuel assembly. Since the Humboldt Bay 7x7 and Dresden 1 8x8 are smaller versions of the 7x7 and 8x8 assemblies they are bounded by the 7x7 and 8x8 assemblies in the GE BWR/2-3 and GE BWR/4-6 classes. Within each array

HOLTEC INTERNATIONAL COPYRIGHTED MATERIAL

type, the fuel assembly with the highest UO_2 mass was analyzed. Since the variations of fuel assemblies within an array type are very minor, it is conservative to choose the assembly with the highest UO_2 mass. For a given array type of assemblies, the one with the highest UO_2 mass will produce the highest radiation source because, for a given burnup (MWD/MTU) and enrichment, it will have produced the most energy and therefore the most fission products. The Humboldt Bay 6x6, Dresden 1 6x6, and LaCrosse assembly classes were not considered in the determination of the bounding fuel assembly. However, these assemblies were analyzed explicitly as discussed below.

Table 5.2.26 presents the characteristics of the fuel assemblies analyzed to determine the design basis zircaloy clad BWR fuel assembly. The corresponding fuel assembly array class from Section 2.1.9 is also listed in the table. The fuel assembly listed for each array type is the assembly that has the highest UO_2 mass. All fuel assemblies in Table 5.2.26 were analyzed at the same burnup and cooling time. The initial enrichment used in these analyses is consistent with Table 5.2.24. The results of the comparison are provided in Table 5.2.28. These results indicate that the 7x7 fuel assembly has the highest radiation source term of the zircaloy clad fuel assembly classes considered in Table 2.1.2. This fuel assembly also has the highest UO_2 mass which confirms that, for a given initial enrichment, burnup, and cooling time, the assembly with the highest UO_2 mass produces the highest radiation source term. According to Reference [5.2.6], the last discharge of a 7x7 assembly was in 1985 and the maximum average burnup for a 7x7 during their operation was 29,000 MWD/MTU. This clearly indicates that the existing 7x7 assemblies have an average burnup and minimum cooling time that is well within the burnup and cooling time limits in Section 2.1.9. Therefore, the 7x7 assembly has never reached the burnup level analyzed in this chapter. However, in the interest of conservatism the 7x7 was chosen as the bounding fuel assembly array type. The power/assembly values used in Table 5.2.26 were calculated by dividing 120% of the thermal power for commercial BWR reactors by the number of assemblies in the core. The higher thermal power, 120%, was used to account for potential power uprates. The power level used for the 7x7 is an additional 4% higher for consistency with previous revisions of the FSAR which also used this assembly as the design basis assembly.

Since the LaCrosse fuel assembly type is a stainless steel clad 10x10 assembly it was analyzed separately. The maximum burnup and minimum cooling time for this assembly are limited to 22,500 MWD/MTU and 10-year cooling as specified in Section 2.1.9. This assembly type is discussed further in Section 5.2.3.

The Humboldt Bay 6x6 and Dresden 1 6x6 fuel are older and shorter fuel than the other array types analyzed and therefore are considered separately. The Dresden 1 6x6 was chosen as the design basis fuel assembly for the Humboldt Bay 6x6 and Dresden 1 6x6 fuel assembly classes because it has the higher UO_2 mass. Dresden 1 also contains a few 6x6 MOX fuel assemblies, which were explicitly analyzed as well.

Reference [5.2.6] indicates that the Dresden 1 6x6 fuel assembly has a higher UO_2 mass than the Dresden 1 8x8 or the Humboldt Bay fuel (6x6 and 7x7). Therefore, the Dresden 1 6x6 fuel assembly was also chosen as the bounding assembly for damaged fuel and fuel debris for the

HOLTEC INTERNATIONAL COPYRIGHTED MATERIAL

Humboldt Bay and Dresden 1 fuel assembly classes.

Since the design basis 6x6 fuel assembly can be intact or damaged, the analysis presented in Section 5.4.2 for the damaged 6x6 fuel assembly also demonstrates the acceptability of storing intact 6x6 fuel assemblies from the Dresden 1 and Humboldt Bay fuel assembly classes.

As discussed below in Section 5.2.5.3, the allowable burnup limits in Section 2.1.9 were calculated for different array classes rather than using the design basis assembly to calculate the allowable burnups for all array classes. As mentioned above, the design basis assembly has the highest neutron and gamma source term of the various array classes for the same burnup and cooling time. In order to account for the fact that different array classes have different allowable burnups for the same cooling time, burnups which bound the 9x9G array class were used with the design basis assembly for the analysis in this chapter because those burnups bound the burnups from all other BWR array classes. This approach assures that the calculated source terms and dose rates will be conservative.

5.2.5.3 Decay Heat Loads and Allowable Burnup and Cooling Times

Section 2.1.6 describes the calculation of the MPC maximum decay heat limits per assembly. These limits, which differ for uniform and regionalized loading, are presented in Section 2.1.9. The allowable burnup and cooling time limits are derived based on the allowable decay heat limits. Since the decay heat of an assembly will vary slightly with enrichment for a fixed burnup and cooling time, an equation is used to represent burnup as a function of decay heat and enrichment. This equation is of the form:

$$B_u = A * q + B * q^2 + C * q^3 + D * E_{235}^2 + E * E_{235} * q + F * E_{235} * q^2 + G$$

where:

B_u = Burnup in MWD/MTU
 q = assembly decay heat (kW)
 E_{235} = wt.% ^{235}U

The coefficients for this equation were developed by fitting ORIGEN-S calculated data for a specific cooling time using GNUPLOT [5.2.16]. ORIGEN-S calculations were performed for enrichments ranging from 0.7 to 5.0 wt.% ^{235}U and burnups from 10,000 to 65,000 MWD/MTU for BWRs and 10,000 to 70,000 MWD/MTU for PWRs. The burnups were increased in 2,500 MWD/MTU increments. Using the ORIGEN-S data, the coefficients A through G were determined and then the constant, G, was adjusted so that all data points were bounded (i.e. calculated burnup less than or equal to ORIGEN-S value) by the fit. The coefficients were calculated using ORIGEN-S data for cooling times from 3 years to 20 years. As a result, Section 2.1.9 provides different equation coefficients for each cooling time from 3 to 20 years. Additional discussion on the determination of the equation coefficients is provided in Appendix 5.F. Since the decay heat increases as the enrichment decreases, the allowable burnup will

HOLTEC INTERNATIONAL COPYRIGHTED MATERIAL

HI-STORM FSAR
REPORT HI-2002444

Rev. 12

decrease as the enrichment decreases. Therefore, the enrichment used to calculate the allowable burnups becomes a minimum enrichment value and assemblies with an enrichment higher than the value used in the equation are acceptable for storage assuming they also meet the corresponding burnup and decay heat requirements. Even though the lower limit of 0.7 wt.% ^{235}U was used in developing the coefficients, these equations are valid for the few assemblies that might exist with enrichments below 0.7 wt.% ^{235}U . This is because the curve fit is very well behaved in the enrichment range from 0.7 to 5.0 wt.% ^{235}U and, therefore, it is expected that the curve fit will remain accurate for enrichments below 0.7 wt.% ^{235}U .

Different array classes or combinations of classes were analyzed separately to determine the allowable burnup as a function of cooling time for the specified allowable decay heat limits. Calculating allowable burnups for individual array classes is appropriate because even two assemblies with the same MTU may have a different allowable burnup for the same allowable cooling time and permissible decay heat. The heavy metal mass specified in Table 5.2.25 and 5.2.26 and Section 2.1.9 for the various array classes is the value that was used in the determination of the coefficients as a function of cooling time and is the maximum for the respective assembly class. Equation coefficients for each array class listed in Tables 5.2.25 and 5.2.26 were developed. In the end, the equation for the 17x17B and 17x17C array classes resulted in almost identical burnups. Therefore, in Section 2.1.9 these array classes were combined and the coefficients for the 17x17C array class were used since these coefficients produce slightly lower allowable burnups.

There is some uncertainty associated with the ORIGEN-S calculations due to uncertainty in the physics data (e.g. cross sections, decay constants, etc.) and the modeling techniques. To estimate this uncertainty, an approach similar to the one in Reference [5.2.14] was used. As a result, the potential error in the ORIGEN-S decay heat calculations was estimated to be in the range of 3.5 to 5.5% at 3 year cooling time and 1.5 to 3.5% at 20 year cooling. The difference is due to the change in isotopes important to decay heat as a function of cooling time. In order to be conservative in the derivation of the coefficients for the burnup equation, a 5% decay heat penalty was applied for both the PWR and BWR array classes.

As a demonstration that the decay heat values used to determine the allowable burnups are conservative, a comparison between these calculated decay heats and the decay heats reported in Reference [5.2.7] are presented in Table 5.2.29. This comparison is made for a burnup of 30,000 MWD/MTU and a cooling time of 5 years. The burnup was chosen based on the limited burnup data available in Reference [5.2.7].

As mentioned above, the fuel assembly burnup and cooling times in Section 2.1.9 were calculated using the decay heat limits which are also stipulated in Section 2.1.9. The burnup and cooling times for the non-fuel hardware, in Section 2.1.9, were chosen based on the radiation source term calculations discussed previously. The fuel assembly burnup, decay heat, and enrichment equations were derived without consideration for the decay heat from BPRAs, TPDs, CRAs, or APSRs. This is acceptable since the user of the HI-STORM 100 system is required to demonstrate compliance with the assembly decay heat limits in Section 2.1.9 regardless of the

HOLTEC INTERNATIONAL COPYRIGHTED MATERIAL

heat source (assembly or non-fuel hardware) and the actual decay heat from the non-fuel hardware is expected to be minimal. In addition, the shielding analysis presented in this chapter conservatively calculates the dose rates using both the burnup and cooling times for the fuel assemblies and non-fuel hardware. Therefore, the safety of the HI-STORM 100 system is guaranteed through the bounding analysis in this chapter, represented by the burnup and cooling time limits in the CoC, and the bounding thermal analysis in Chapter 4, represented by the decay heat limits in the CoC.

5.2.5.4 Burnup, Enrichment and Cooling time values for Site Specific Dose Analyses

As discussed earlier in this Chapter, site-specific dose evaluations are required to show compliance with the regulatory requirements, and those need to consider the types, burnups, enrichments and cooling times of the fuel to be stored. Since it is impractical to evaluate every fuel assembly individually, a bounding approach is typically used where assemblies are grouped and bounding characteristics are selected and evaluated for each group. Recommendations and guidance for those selections are as follows:

For the fuel assembly type, the one approach would be to use the design basis assembly type, since this has been shown to bound all other assembly types (see Subsections 5.2.5.1 and 5.2.5.2). However, if this approach is considered too conservative, it is also acceptable to utilize a site-specific fuel assembly type. In this case, that fuel assembly type needs to be considered in both the radiation transport analyses and the source term evaluations.

For burnups, enrichments and cooling times, selecting an appropriate burnup and enrichment combination or combinations (for given lower bound cooling times) could be difficult, since the more conservative values are a higher burnup but a lower enrichment (see Subsection 5.2.2). One approach would be to have a single group, i.e. select bounding values for all those parameters: upper bound burnup, lower bound enrichment, and lower bound cooling time. However, this could be excessively conservative, since combinations of high burnup and low enrichment are typically not found in spent fuel. A more practical approach would be to establish several groups, each with an upper bound burnup and lower bound enrichment. A separate evaluation may be required for each group in that case. However, with the help of the information shown in Table 5.2.24 it may be possible to avoid multiple analyses and demonstrate compliance with a single set of burnup, enrichment and cooling time. To support this approach, the results of source term calculation for all burnup and enrichment combinations listed in the table were compared, for the entire neutron and photon energy spectrum used in the dose analyses. The comparison shows, that in all cases, the source terms for the higher burnup, with the correspondingly listed enrichment, bound those with any lower burnup in the same burnup column, again with the correspondingly listed enrichment. The burnup column refers to either the column of the upper bound or lower bound burnups of the burnup ranges. For example, BWR fuel with 45,000 MWD/MTU and 3.0 wt% enrichment bounds BWR fuel with 40,000 MWD/MTU and 2.9 wt% enrichment, or PWR fuel with 50,000 MWD/MTU and 3.9 wt% bounds PWR fuel with 45,000 MWD/MTU and 3.6 wt% enrichment. Also, the maximum burnup for PWR and BWR, together with the correspondingly listed enrichment, bounds all other burnup and enrichment combination

for PWR and BWR fuel, respectively. Using this comparison, it may be possible to bound the entire inventory with a single burnup and enrichment value (in combination with a lower bound cooling time). Additional considerations for this approach are as follows:

- The comparison was performed for design basis fuel. It is expected that the same conclusions would be valid for other fuel types, but that has not been demonstrated.
- Small deviations from the combinations listed in Table 5.2.24 for a limited number of assemblies would have an insignificant effect on doses (see Section 5.2.2) and may therefore be accepted without further evaluation.
- Assemblies with an enrichment below that listed in Table 5.2.24 for a given burnup may still be bounded by the assemblies with a higher burnup listed in that table, since the comparison shows margin in most cases. Therefore, a site-specific expansion of the table using source term comparisons may still allow a single bounding burnup and enrichment combination to be used in the dose analysis.

5.2.6 Thoria Rod Canister

Dresden Unit 1 has a single DFC containing 18 thoria rods which have obtained a relatively low burnup, 16,000 MWD/MTU. These rods were removed from two 8x8 fuel assemblies which contained 9 rods each. The irradiation of thorium produces an isotope which is not commonly found in depleted uranium fuel. Th-232 when irradiated produces U-233. The U-233 can undergo an (n,2n) reaction which produces U-232. The U-232 decays to produce Tl-208 which produces a 2.6 MeV gamma during Beta decay. This results in a significant source in the 2.5-3.0 MeV range which is not commonly present in depleted uranium fuel. Therefore, this single DFC container was analyzed to determine if it was bounded by the current shielding analysis.

A radiation source term was calculated for the 18 thoria rods using SAS2H and ORIGEN-S for a burnup of 16,000 MWD/MTU and a cooling time of 18 years. Table 5.2.36 describes the 8x8 fuel assembly that contains the thoria rods. Table 5.2.37 and 5.2.38 show the gamma and neutron source terms, respectively, that were calculated for the 18 thoria rods in the thoria rod canister. Comparing these source terms to the design basis 6x6 source terms for Dresden Unit 1 fuel in Tables 5.2.7 and 5.2.18 clearly indicates that the design basis source terms bound the thoria rods source terms in all neutron groups and in all gamma groups except the 2.5-3.0 MeV group. As mentioned above, the thoria rods have a significant source in this energy range due to the decay of Tl-208.

Section 5.4.8 provides a further discussion of the thoria rod canister and its acceptability for storage in the HI-STORM 100 System.

5.2.7 Fuel Assembly Neutron Sources

Neutron source assemblies (NSAs) are used in reactors for startup. There are different types of neutron sources (e.g. californium, americium-beryllium, plutonium-beryllium, polonium-beryllium, antimony-beryllium). These neutron sources are typically inserted into the water rod

HOLTEC INTERNATIONAL COPYRIGHTED MATERIAL

of a fuel assembly and are usually removable.

5.2.7.1 PWR Neutron Source Assemblies

During in-core operations, the stainless steel and inconel portions of the NSAs become activated, producing a significant amount of Co-60. Reference [5.2.5] provides the masses of steel and inconel for the NSAs. Using these masses it was determined that the total activation of a primary or secondary source is bound by the total activation of a BPRA (see Table 5.2.31). Therefore, storage of NSAs is acceptable and a detailed dose rate analysis using the gamma source from activated NSAs is not performed. Conservatively, the burnup and cooling time limits for TPDs, as listed in Section 2.1.9, are being applied to NSAs since they cover a larger range of burnups.

Antimony-beryllium sources are used as secondary (regenerative) neutron sources in reactor cores. The Sb-Be source produces neutrons from a gamma-n reaction in the beryllium, where the gamma originates from the decay of neutron-activated antimony. The very short half-life of ^{124}Sb , 60.2 days, however results in a complete decay of the initial amount generated in the reactor within a few years after removal from the reactor. The production of neutrons by the Sb-Be source through regeneration in the MPC is orders of magnitude lower than the design-basis fuel assemblies. Therefore Sb-Be sources do not contribute to the total neutron source in the MPC.

Primary neutron sources (californium, americium-beryllium, plutonium-beryllium and polonium-beryllium) are usually placed in the reactor with a source-strength on the order of $5\text{E}+08$ n/s. This source strength is similar to, but not greater than, the maximum design-basis fuel assembly source strength listed in Tables 5.2.15 and 5.2.16.

By the time NSAs are stored in the MPC, the primary neutron sources will have been decaying for many years since they were first inserted into the reactor (typically greater than 10 years). For the ^{252}Cf source, with a half-life of 2.64 years, this means a significant reduction in the source intensity; while the ^{210}Po -Be source, with a half-life of 138 days, is virtually eliminated. The ^{238}Pu -Be and ^{241}Am -Be sources, however, have a significantly longer half-life, 87.4 years and 433 years, respectively. As a result, their source intensity does not decrease significantly before storage in the MPC. Since the ^{238}Pu -Be and ^{241}Am -Be sources may have a source intensity similar to a design-basis fuel assembly when they are stored in the MPC, only a single NSA is permitted for storage in the MPC. Since storage of a single NSA would not significantly increase the total neutron source in an MPC, storage of NSAs is acceptable and detailed dose rate analysis of the neutron source from NSAs is not performed.

For ease of implementation in the CoC, the restriction concerning the number of NSAs is being applied to all types of NSAs. In addition, conservatively NSAs are required to be stored in the inner region of the MPC basket as specified in Section 2.1.9.

5.2.7.2 BWR Neutron Source Assemblies

Dresden Unit 1 has a few antimony-beryllium neutron sources. These sources have been analyzed

HOLTEC INTERNATIONAL COPYRIGHTED MATERIAL

in Section 5.4.7 to demonstrate that they are acceptable for storage in the HI-STORM 100 System.

5.2.8 Stainless Steel Channels

The LaCrosse nuclear plant used two types of channels for their BWR assemblies: stainless steel and zircaloy. Since the irradiation of zircaloy does not produce significant activation, there are no restrictions on the storage of these channels and they are not explicitly analyzed in this chapter. The stainless steel channels, however, can produce a significant amount of activation, predominantly from Co-60. LaCrosse has thirty-two stainless steel channels, a few of which have been in the reactor core for, approximately, the lifetime of the plant. Therefore, the activation of the stainless steel channels was conservatively calculated to demonstrate that they are acceptable for storage in the HI-STORM 100 system. For conservatism, the number of stainless steel channels in an MPC-68 is being limited to sixteen and Section 2.1.9 requires that these channels be stored in the inner sixteen locations.

The activation of a single stainless steel channel was calculated by simulating the irradiation of the channels with ORIGEN-S using the flux calculated from the LaCrosse fuel assembly. The mass of the steel channel in the active fuel zone (83 inches) was used in the analysis. For burnups beyond 22,500 MWD/MTU, it was assumed, for the purpose of the calculation, that the burned fuel assembly was replaced with a fresh fuel assembly every 22,500 MWD/MTU. This was achieved in ORIGEN-S by resetting the flux levels and cross sections to the 0 MWD/MTU condition after every 22,500 MWD/MTU.

LaCrosse was commercially operated from November 1969 until it was shutdown in April 1987. Therefore, the shortest cooling time for the assemblies and the channels is 13 years. Assuming the plant operated continually from 11/69 until 4/87, approximately 17.5 years or 6388 days, the accumulated burnup for the channels would be 186,000 MWD/MTU (6388 days times 29.17 MW/MTU from Table 5.2.3). Therefore, the cobalt activity calculated for a single stainless steel channel irradiated for 180,000 MWD/MTU was calculated to be 667 curies of Co-60 for 13 years cooling. This is equivalent to a source of $4.94\text{E}+13$ photons/sec in the energy range of 1.0-1.5 MeV.

In order to demonstrate that sixteen stainless steel channels are acceptable for storage in an MPC-68, a comparison of source terms is performed. Table 5.2.8 indicates that the source term for the LaCrosse design basis fuel assembly in the 1.0-1.5 MeV range is $6.34\text{E}+13$ photons/sec for 10 years cooling, assuming a 144 inch active fuel length. This is equivalent to $4.31\text{E}+15$ photons/sec/cask. At 13 years cooling, the fuel source term in that energy range decreases to $4.31\text{E}+13$ photons/sec which is equivalent to $2.93\text{E}+15$ photons/sec/cask. If the source term from the stainless steel channels is scaled to 144 inches and added to the 13 year fuel source term the result is $4.30\text{E}+15$ photons/sec/cask ($2.93\text{E}+15$ photons/sec/cask + $4.94\text{E}+13$ photons/sec/channel x 144 inch/83 inch x 16 channels/cask). This number is equivalent to the 10 year $4.31\text{E}+15$ photons/sec/cask source calculated from Table 5.2.8 and used in the shielding

analysis in this chapter. Therefore, it is concluded that the storage of 16 stainless steel channels in an MPC-68 is acceptable.

Table 5.2.1

DESCRIPTION OF DESIGN BASIS ZIRCALOY CLAD FUEL

	PWR	BWR
Assembly type/class	B&W 15x15	GE 7x7
Active fuel length (in.)	144	144
No. of fuel rods	208	49
Rod pitch (in.)	0.568	0.738
Cladding material	Zircaloy-4	Zircaloy-2
Rod diameter (in.)	0.428	0.570
Cladding thickness (in.)	0.0230	0.0355
Pellet diameter (in.)	0.3742	0.488
Pellet material	UO ₂	UO ₂
Pellet density (gm/cc)	10.412 (95% of theoretical)	10.412 (95% of theoretical)
Enrichment (w/o ²³⁵ U)	3.6	3.2
Specific power (MW/MTU)	40	30
Weight of UO ₂ (kg) ^{††}	562.029	225.177
Weight of U (kg) ^{††}	495.485	198.516

Notes:

1. The B&W 15x15 is the design basis assembly for the following fuel assembly classes listed in Table 2.1.1: B&W 15x15, B&W 17x17, CE 14x14, CE 16x16, WE 14x14, WE 15x15, CE 15x15, WE 17x17, St. Lucie, and Ft. Calhoun.
2. The GE 7x7 is the design basis assembly for the following fuel assembly classes listed in Table 2.1.2: GE BWR/2-3, GE BWR/4-6, Humboldt Bay 7x7, and Dresden 1 8x8.

^{††} Derived from parameters in this table.

HOLTEC INTERNATIONAL COPYRIGHTED MATERIAL

HI-STORM FSAR
REPORT HI-2002444

Rev. 12

5.2-20

Table 5.2.1 (continued)

DESCRIPTION OF DESIGN BASIS FUEL

	PWR	BWR
No. of Water Rods	17	0
Water Rod O.D. (in.)	0.53	N/A
Water Rod Thickness (in.)	0.016	N/A
Lower End Fitting (kg)	8.16 (steel) 1.3 (inconel)	4.8 (steel)
Gas Plenum Springs (kg)	0.48428 (inconel) 0.23748 (steel)	1.1 (steel)
Gas Plenum Spacer (kg)	0.82824	N/A
Expansion Springs (kg)	N/A	0.4 (steel)
Upper End Fitting (kg)	9.28 (steel)	2.0 (steel)
Handle (kg)	N/A	0.5 (steel)
Incore Grid Spacers (kg)	4.9 (inconel)	0.33 (inconel springs)

HOLTEC INTERNATIONAL COPYRIGHTED MATERIAL

HI-STORM FSAR
REPORT HI-2002444

Rev. 12

5.2-21

Table 5.2.2

DESCRIPTION OF DESIGN BASIS GE 6x6 ZIRCALOY CLAD FUEL

	BWR
Fuel type	GE 6x6
Active fuel length (in.)	110
No. of fuel rods	36
Rod pitch (in.)	0.694
Cladding material	Zircaloy-2
Rod diameter (in.)	0.5645
Cladding thickness (in.)	0.035
Pellet diameter (in.)	0.494
Pellet material	UO ₂
Pellet density (gm/cc)	10.412 (95% of theoretical)
Enrichment (w/o ²³⁵ U)	2.24
Burnup (MWD/MTU)	30,000
Cooling Time (years)	18
Specific power (MW/MTU)	16.5
Weight of UO ₂ (kg) [†]	129.5
Weight of U (kg) [†]	114.2

Notes:

1. The 6x6 is the design basis damaged fuel assembly for the Humboldt Bay (all array types) and the Dresden 1 (all array types) damaged fuel assembly classes. It is also the design basis fuel assembly for the intact Humboldt Bay 6x6 and Dresden 1 6x6 fuel assembly classes.
2. This design basis damaged fuel assembly is also the design basis fuel assembly for fuel debris.

[†] Derived from parameters in this table.

HOLTEC INTERNATIONAL COPYRIGHTED MATERIAL

HI-STORM FSAR
REPORT HI-2002444

Rev. 12

5.2-22

Table 5.2.3

DESCRIPTION OF DESIGN BASIS STAINLESS STEEL CLAD FUEL

	PWR	BWR
Fuel type	WE 15x15	LaCrosse 10x10
Active fuel length (in.)	144	144
No. of fuel rods	204	100
Rod pitch (in.)	0.563	0.565
Cladding material	304 SS	348H SS
Rod diameter (in.)	0.422	0.396
Cladding thickness (in.)	0.0165	0.02
Pellet diameter (in.)	0.3825	0.35
Pellet material	UO ₂	UO ₂
Pellet density (gm/cc)	10.412 (95% of theoretical)	10.412 (95% of theoretical)
Enrichment (w/o ²³⁵ U)	3.5	3.5
Burnup (MWD/MTU) [†]	40,000 (MPC-24 and 32)	22,500 (MPC-68)
Cooling Time (years) [†]	8 (MPC-24), 9 (MPC-32)	10 (MPC-68)
Specific power (MW/MTU)	37.96	29.17
No. of Water Rods	21	0
Water Rod O.D. (in.)	0.546	N/A
Water Rod Thickness (in.)	0.017	N/A

Notes:

1. The WE 15x15 is the design basis assembly for the following fuel assembly classes listed in Table 2.1.1: Indian Point 1, Haddam Neck, and San Onofre 1.
2. The LaCrosse 10x10 is the design basis assembly for the following fuel assembly class listed in Table 2.1.2: LaCrosse.

[†] Burnup and cooling time combinations are equivalent to or conservatively bound the limits in Section 2.1.9.

HOLTEC INTERNATIONAL COPYRIGHTED MATERIAL

HI-STORM FSAR
REPORT HI-2002444

Rev. 12

5.2-23

Table 5.2.4

CALCULATED MPC-32 PWR FUEL GAMMA SOURCE PER ASSEMBLY
FOR DESIGN BASIS ZIRCALOY CLAD FUEL
FOR VARYING BURNUPS AND COOLING TIMES

Lower Energy (MeV)	Upper Energy (MeV)	45,000 MWD/MTU 3 Year Cooling		69,000 MWD/MTU 5 Year Cooling	
		(MeV/s)	(Photons/s)	(MeV/s)	(Photons/s)
0.45	0.7	3.05E+15	5.30E+15	3.26E+15	5.67E+15
0.7	1.0	1.37E+15	1.62E+15	1.23E+15	1.44E+15
1.0	1.5	2.96E+14	2.37E+14	2.69E+14	2.15E+14
1.5	2.0	2.91E+13	1.66E+13	1.41E+13	8.08E+12
2.0	2.5	3.79E+13	1.68E+13	7.56E+12	3.36E+12
2.5	3.0	1.14E+12	4.13E+11	3.56E+11	1.29E+11
Total		4.78E+15	7.18E+15	4.78E+15	7.34E+15

HOLTEC INTERNATIONAL COPYRIGHTED MATERIAL

HI-STORM FSAR
REPORT HI-2002444

Rev. 12

Table 5.2.5

CALCULATED MPC-24 PWR FUEL GAMMA SOURCE PER ASSEMBLY
 FOR DESIGN BASIS ZIRCALOY CLAD FUEL
 FOR VARYING BURNUPS AND COOLING TIMES

Lower Energy (MeV)	Upper Energy (MeV)	60,000 MWD/MTU 3 Year Cooling		75,000 MWD/MTU 5 Year Cooling	
		(MeV/s)	(Photons/s)	(MeV/s)	(Photons/s)
0.45	0.7	4.11E+15	7.14E+15	3.55E+15	6.17E+15
0.7	1.0	1.98E+15	2.33E+15	1.36E+15	1.60E+15
1.0	1.5	4.04E+14	3.23E+14	2.94E+14	2.35E+14
1.5	2.0	3.41E+13	1.95E+13	1.50E+13	8.59E+12
2.0	2.5	3.95E+13	1.76E+13	7.63E+12	3.39E+12
2.5	3.0	1.29E+12	4.70E+11	3.72E+11	1.35E+11
Total		6.57E+15	9.84E+15	5.23E+15	8.02E+15

HOLTEC INTERNATIONAL COPYRIGHTED MATERIAL

HI-STORM FSAR
 REPORT HI-2002444

Rev. 12

Table 5.2.6

CALCULATED MPC-68 BWR FUEL GAMMA SOURCE PER ASSEMBLY
 FOR DESIGN BASIS ZIRCALOY CLAD FUEL
 FOR VARYING BURNUPS AND COOLING TIMES

Lower Energy (MeV)	Upper Energy (MeV)	50,000 MWD/MTU 3 Year Cooling	
		(MeV/s)	(Photons/s)
0.45	0.7	1.28E+15	2.23E+15
0.7	1.0	5.76E+14	6.77E+14
1.0	1.5	1.18E+14	9.47E+13
1.5	2.0	1.04E+13	5.92E+12
2.0	2.5	1.20E+13	5.33E+12
2.5	3.0	4.04E+11	1.47E+11
Total		2.00E+15	3.01E+15

Table 5.2.7

CALCULATED MPC-68 BWR FUEL GAMMA SOURCE PER ASSEMBLY
FOR DESIGN BASIS ZIRCALOY CLAD GE 6x6 FUEL

Lower Energy (MeV)	Upper Energy (MeV)	30,000 MWD/MTU 18-Year Cooling	
		(MeV/s)	(Photons/s)
4.5e-01	7.0e-01	1.53e+14	2.65e+14
7.0e-01	1.0	3.97e+12	4.67e+12
1.0	1.5	3.67e+12	2.94e+12
1.5	2.0	2.20e+11	1.26e+11
2.0	2.5	1.35e+09	5.99e+08
2.5	3.0	7.30e+07	2.66e+07
Totals		1.61e+14	2.73e+14

HOLTEC INTERNATIONAL COPYRIGHTED MATERIAL

HI-STORM FSAR
REPORT HI-2002444

Rev. 12

5.2-27

Table 5.2.8

CALCULATED BWR FUEL GAMMA SOURCE PER ASSEMBLY
FOR STAINLESS STEEL CLAD FUEL

Lower Energy (MeV)	Upper Energy (MeV)	22,500 MWD/MTU 10-Year Cooling	
		(MeV/s)	(Photons/s)
4.5e-01	7.0e-01	2.72e+14	4.74e+14
7.0e-01	1.0	1.97e+13	2.31e+13
1.0	1.5	7.93e+13	6.34e+13
1.5	2.0	4.52e+11	2.58e+11
2.0	2.5	3.28e+10	1.46e+10
2.5	3.0	1.69e+9	6.14e+8
Totals		3.72e+14	5.61e+14

Note: These source terms were calculated for a 144-inch fuel length. The limits in Section 2.1.9 are based on the actual 83-inch active fuel length.

Table 5.2.9

CALCULATED PWR FUEL GAMMA SOURCE PER ASSEMBLY
FOR STAINLESS STEEL CLAD FUEL

Lower Energy (MeV)	Upper Energy (MeV)	40,000 MWD/MTU 8-Year Cooling		40,000 MWD/MTU 9-Year Cooling	
		(MeV/s)	(Photons/s)	(MeV/s)	(Photons/s)
4.5e-01	7.0e-01	1.37e+15	2.38e+15	1.28E+15	2.22E+15
7.0e-01	1.0	2.47e+14	2.91e+14	1.86E+14	2.19E+14
1.0	1.5	4.59e+14	3.67e+14	4.02E+14	3.21E+14
1.5	2.0	3.99e+12	2.28e+12	3.46E+12	1.98E+12
2.0	2.5	5.85e+11	2.60e+11	2.69E+11	1.20E+11
2.5	3.0	3.44e+10	1.25e+10	1.77E+10	6.44E+09
Totals		2.08e+15	3.04e+15	1.87E+15	2.76E+15

Note: These source terms were calculated for a 144-inch fuel length. The limits in Section 2.1.9 are based on the actual 122-inch active fuel length.

Table 5.2.10

SCALING FACTORS USED IN CALCULATING THE ⁶⁰Co SOURCE

Region	PWR	BWR
Handle	N/A	0.05
Upper End Fitting	0.1	0.1
Gas Plenum Spacer	0.1	N/A
Expansion Springs	N/A	0.1
Gas Plenum Springs	0.2	0.2
Incore Grid Spacer	1.0	1.0
Lower End Fitting	0.2	0.15

Table 5.2.11

CALCULATED MPC-32 ⁶⁰Co SOURCE PER ASSEMBLY FOR DESIGN BASIS
 ZIRCALOY CLAD FUEL
 AT DESIGN BASIS BURNUP AND COOLING TIME

Location	45,000 MWD/MTU and 3-Year Cooling (curies)	69,000 MWD/MTU and 5-Year Cooling (curies)
Lower End Fitting	217.58	208.12
Gas Plenum Springs	16.60	15.88
Gas Plenum Spacer	9.52	9.11
Expansion Springs	N/A	N/A
Incore Grid Spacers	563.50	539.00
Upper End Fitting	106.72	102.08
Handle	N/A	N/A

HOLTEC INTERNATIONAL COPYRIGHTED MATERIAL

HI-STORM FSAR
 REPORT HI-2002444

Rev. 12

Table 5.2.12

CALCULATED MPC-24 ⁶⁰Co SOURCE PER ASSEMBLY FOR DESIGN BASIS
 ZIRCALOY CLAD FUEL
 AT DESIGN BASIS BURNUP AND COOLING TIME

Location	60,000 MWD/MTU and 3-Year Cooling (curies)	75,000 MWD/MTU and - 5 Year Cooling (curies)
Lower End Fitting	249.74	219.47
Gas Plenum Springs	19.05	16.74
Gas Plenum Spacer	10.93	9.61
Expansion Springs	N/A	N/A
Incore Grid Spacers	646.80	568.40
Upper End Fitting	122.50	107.65
Handle	N/A	N/A

Table 5.2.13

CALCULATED MPC-68 ⁶⁰Co SOURCE PER ASSEMBLY FOR DESIGN BASIS
 ZIRCALOY CLAD FUEL
 AT DESIGN BASIS BURNUP AND COOLING TIME

Location	50,000 MWD/MTU and 3-Year Cooling (curies)
Lower End Fitting	90.55
Gas Plenum Springs	27.67
Gas Plenum Spacer	N/A
Expansion Springs	5.03
Grid Spacer Springs	41.50
Upper End Fitting	25.15
Handle	3.14

Table 5.2.14

THIS TABLE INTENTIONALLY DELETED

HOLTEC INTERNATIONAL COPYRIGHTED MATERIAL

HI-STORM FSAR
REPORT HI-2002444

Rev. 12

5.2-34

HI-STORM 100 FSAR, NON-PROPRIETARY
REVISION 12
MARCH 12, 2014

Table 5.2.15

CALCULATED MPC-32 PWR NEUTRON SOURCE PER ASSEMBLY
FOR DESIGN BASIS ZIRCALOY CLAD FUEL
FOR VARYING BURNUPS AND COOLING TIMES

Lower Energy (MeV)	Upper Energy (MeV)	45,000 MWD/MTU 3-Year Cooling (Neutrons/s)	69,000 MWD/MTU 5-Year Cooling (Neutrons/s)
1.0e-01	4.0e-01	1.77E+07	5.31E+07
4.0e-01	9.0e-01	9.03E+07	2.71E+08
9.0e-01	1.4	8.27E+07	2.48E+08
1.4	1.85	6.09E+07	1.82E+08
1.85	3.0	1.08E+08	3.21E+08
3.0	6.43	9.77E+07	2.92E+08
6.43	20.0	8.66E+06	2.60E+07
Totals		4.65E+08	1.39E+09

HOLTEC INTERNATIONAL COPYRIGHTED MATERIAL

HI-STORM FSAR
REPORT HI-2002444

Rev: 12

5.2-35

HI-STORM 100 FSAR, NON-PROPRIETARY
REVISION 12
MARCH 12, 2014

Table 5.2.16

CALCULATED MPC-24 PWR NEUTRON SOURCE PER ASSEMBLY
 FOR DESIGN BASIS ZIRCALOY CLAD FUEL
 FOR VARYING BURNUPS AND COOLING TIMES

Lower Energy (MeV)	Upper Energy (MeV)	60,000 MWD/MTU 3-Year Cooling (Neutrons/s)	75,000 MWD/MTU 5-Year Cooling (Neutrons/s)
1.0e-01	4.0e-01	3.76E+07	6.82E+07
4.0e-01	9.0e-01	1.92E+08	3.48E+08
9.0e-01	1.4	1.76E+08	3.18E+08
1.4	1.85	1.29E+08	2.34E+08
1.85	3.0	2.28E+08	4.11E+08
3.0	6.43	2.08E+08	3.75E+08
6.43	20.0	1.84E+07	3.34E+07
Totals		9.89E+08	1.79E+09

Table 5.2.17

CALCULATED MPC-68 BWR NEUTRON SOURCE PER ASSEMBLY
 FOR DESIGN BASIS ZIRCALOY CLAD FUEL
 FOR VARYING BURNUPS AND COOLING TIMES

Lower Energy (MeV)	Upper Energy (MeV)	50,000 MWD/MTU 3-Year Cooling (Neutrons/s)
1.0e-01	4.0e-01	9.79E+06
4.0e-01	9.0e-01	5.00E+07
9.0e-01	1.4	4.57E+07
1.4	1.85	3.37E+07
1.85	3.0	5.93E+07
3.0	6.43	5.40E+07
6.43	20.0	4.79E+06
Totals		2.57E+08

HOLTEC INTERNATIONAL COPYRIGHTED MATERIAL

HI-STORM FSAR
 REPORT HI-2002444

Rev. 12

5.2-37

Table 5.2.18

CALCULATED MPC-68 BWR NEUTRON SOURCE PER ASSEMBLY
FOR DESIGN BASIS ZIRCALOY CLAD GE 6x6 FUEL

Lower Energy (MeV)	Upper Energy (MeV)	30,000 MWD/MTU 18-Year Cooling (Neutrons/s)
1.0e-01	4.0e-01	8.22e+5
4.0e-01	9.0e-01	4.20e+6
9.0e-01	1.4	3.87e+6
1.4	1.85	2.88e+6
1.85	3.0	5.18e+6
3.0	6.43	4.61e+6
6.43	20.0	4.02e+5
Total		2.20e+7

HOLTEC INTERNATIONAL COPYRIGHTED MATERIAL

HI-STORM FSAR
REPORT HI-2002444

Rev. 12

5.2-38

Table 5.2.19

CALCULATED BWR NEUTRON SOURCE PER ASSEMBLY
FOR STAINLESS STEEL CLAD FUEL

Lower Energy (MeV)	Upper Energy (MeV)	22,500 MWD/MTU 10-Year Cooling (Neutrons/s)
1.0e-01	4.0e-01	2.23e+5
4.0e-01	9.0e-01	1.14e+6
9.0e-01	1.4	1.07e+6
1.4	1.85	8.20e+5
1.85	3.0	1.56e+6
3.0	6.43	1.30e+6
6.43	20.0	1.08e+5
Total		6.22e+6

Note: These source terms were calculated for a 144-inch fuel length. The limits in Section 2.1.9 are based on the actual 83-inch active fuel length.

Table 5.2.20

CALCULATED PWR NEUTRON SOURCE PER ASSEMBLY
FOR STAINLESS STEEL CLAD FUEL

Lower Energy (MeV)	Upper Energy (MeV)	40,000 MWD/MTU 8-Year Cooling (Neutrons/s)	40,000 MWD/MTU 9-Year Cooling (Neutrons/s)
1.0e-01	4.0e-01	1.04e+7	1.01E+07
4.0e-01	9.0e-01	5.33e+7	5.14E+07
9.0e-01	1.4	4.89e+7	4.71E+07
1.4	1.85	3.61e+7	3.48E+07
1.85	3.0	6.41e+7	6.18E+07
3.0	6.43	5.79e+7	5.58E+07
6.43	20.0	5.11e+6	4.92E+06
Totals		2.76e+8	2.66E+08

Note: These source terms were calculated for a 144-inch fuel length. The limits in Section 2.1.9 are based on the actual 122-inch active fuel length.

Table 5.2.21

DESCRIPTION OF DESIGN BASIS ZIRCALOY CLAD MIXED OXIDE FUEL

	BWR
Fuel type	GE 6x6
Active fuel length (in.)	110
No. of fuel rods	36
Rod pitch (in.)	0.696
Cladding material	Zircaloy-2
Rod diameter (in.)	0.5645
Cladding thickness (in.)	0.036
Pellet diameter (in.)	0.482
Pellet material	UO ₂ and PuUO ₂
No. of UO ₂ Rods	27
No. of PuUO ₂ rods	9
Pellet density (gm/cc)	10.412 (95% of theoretical)
Enrichment (w/o ²³⁵ U) [†]	2.24 (UO ₂ rods) 0.711 (PuUO ₂ rods)
Burnup (MWD/MTU)	30,000
Cooling Time (years)	18
Specific power (MW/MTU)	16.5
Weight of UO ₂ ,PuUO ₂ (kg) ^{††}	123.3
Weight of U,Pu (kg) ^{††}	108.7

[†] See Table 5.3.3 for detailed composition of PuUO₂ rods.

^{††} Derived from parameters in this table.

HOLTEC INTERNATIONAL COPYRIGHTED MATERIAL

HI-STORM FSAR
REPORT HI-2002444

Rev. 12

5.2-41

Table 5.2.22

CALCULATED MPC-68 BWR FUEL GAMMA SOURCE PER ASSEMBLY
FOR DESIGN BASIS ZIRCALOY CLAD MIXED OXIDE FUEL

Lower Energy (MeV)	Upper Energy (MeV)	30,000 MWD/MTU 18-Year Cooling	
		(MeV/s)	(Photons/s)
4.5e-01	7.0e-01	1.45e+14	2.52e+14
7.0e-01	1.0	3.87e+12	4.56e+12
1.0	1.5	3.72e+12	2.98e+12
1.5	2.0	2.18e+11	1.25e+11
2.0	2.5	1.17e+9	5.22e+8
2.5	3.0	9.25e+7	3.36e+7
Totals		1.53e+14	2.60e+14

Table 5.2.23

CALCULATED MPC-68 BWR NEUTRON SOURCE PER ASSEMBLY
FOR DESIGN BASIS ZIRCALOY CLAD MIXED OXIDE FUEL

Lower Energy (MeV)	Upper Energy (MeV)	30,000 MWD/MTU 18-Year Cooling (Neutrons/s)
1.0e-01	4.0e-01	1.24e+6
4.0e-01	9.0e-01	6.36e+6
9.0e-01	1.4	5.88e+6
1.4	1.85	4.43e+6
1.85	3.0	8.12e+6
3.0	6.43	7.06e+6
6.43	20.0	6.07e+5
Totals		3.37e+7

HOLTEC INTERNATIONAL COPYRIGHTED MATERIAL

HI-STORM FSAR
REPORT HI-2002444

Rev. 12

Table 5.2.24

INITIAL ENRICHMENTS USED IN THE SOURCE TERM CALCULATIONS

Burnup Range (MWD/MTU)	Initial Enrichment (wt.% ²³⁵ U)
BWR Fuel	
20,000-25,000	2.1
25,000-30,000	2.4
30,000-35,000	2.6
35,000-40,000	2.9
40,000-45,000	3.0
45,000-50,000	3.2
50,000-55,000	3.6
55,000-60,000	4.0
60,000-65,000	4.4
65,000-70,000	4.8
PWR Fuel	
20,000-25,000	2.3
25,000-30,000	2.6
30,000-35,000	2.9
35,000-40,000	3.2
40,000-45,000	3.4
45,000-50,000	3.6
50,000-55,000	3.9
55,000-60,000	4.2
60,000-65,000	4.5
65,000-70,000	4.8
70,000-75,000	5.0

Note: The burnup ranges do not overlap. Therefore, 20,000-25,000 MWD/MTU means 20,000-24,999.9 MWD/MTU, etc. This note does not apply to the maximum burnups of 70,000 and 75,000 MWD/MTU.

HOLTEC INTERNATIONAL COPYRIGHTED MATERIAL

Table 5.2.25 (page 1 of 2)

DESCRIPTION OF EVALUATED ZIRCALOY CLAD PWR FUEL

Assembly	WE 14x14	WE 14x14	WE 15x15	WE 17x17	WE 17x17
Fuel assembly array class	14x14B	14x14A	15x15AB C	17x17B	17x17A
Active fuel length (in.)	144	144	144	144	144
No. of fuel rods	179	179	204	264	264
Rod pitch (in.)	0.556	0.556	0.563	0.496	0.496
Cladding material	Zr-4	Zr-4	Zr-4	Zr-4	Zr-4
Rod diameter (in.)	0.422	0.4	0.422	0.374	0.36
Cladding thickness (in.)	0.0243	0.0243	0.0245	0.0225	0.0225
Pellet diameter (in.)	0.3659	0.3444	0.3671	0.3232	0.3088
Pellet material	UO ₂	UO ₂	UO ₂	UO ₂	UO ₂
Pellet density (gm/cc) (% of theoretical)	10.522 (96%)	10.522 (96%)	10.522 (96%)	10.522 (96%)	10.522 (96%)
Enrichment (wt.% ²³⁵ U)	3.4	3.4	3.4	3.4	3.4
Burnup (MWD/MTU)	40,000	40,000	40,000	40,000	40,000
Cooling time (years)	5	5	5	5	5
Power/assembly (MW)	15.0	15.0	18.6	20.4	20.4
Specific power (MW/MTU)	36.409	41.097	39.356	43.031	47.137
Weight of UO ₂ (kg) [†]	467.319	414.014	536.086	537.752	490.901
Weight of U (kg) [†]	411.988	364.994	472.613	474.082	432.778
No. of Guide Tubes	17	17	21	25	25
Guide Tube O.D. (in.)	0.539	0.539	0.546	0.474	0.474
Guide Tube Thickness (in.)	0.0170	0.0170	0.0170	0.0160	0.0160

[†] Derived from parameters in this table.

HOLTEC INTERNATIONAL COPYRIGHTED MATERIAL

HI-STORM FSAR
REPORT HI-2002444

Rev. 12

5.2-45

Table 5.2.25 (page 2 of 2)

DESCRIPTION OF EVALUATED ZIRCALOY CLAD PWR FUEL

Assembly	CE 14×14	CE 16×16	B&W 15×15	B&W 17×17
Fuel assembly array class	14x14C	16x16A	15x15DEF HI	17x17C
Active fuel length (in.)	144	150	144	144
No. of fuel rods	176	236	208	264
Rod pitch (in.)	0.580	0.5063	0.568	0.502
Cladding material	Zr-4	Zr-4	Zr-4	Zr-4
Rod diameter (in.)	0.440	0.382	0.428	0.377
Cladding thickness (in.)	0.0280	0.0250	0.0230	0.0220
Pellet diameter (in.)	0.3805	0.3255	0.3742	0.3252
Pellet material	UO ₂	UO ₂	UO ₂	UO ₂
Pellet density (gm/cc) (95% of theoretical)	10.522 (96%)	10.522 (96%)	10.412 (95%)	10.522 (96%)
Enrichment (wt.% ²³⁵ U)	3.4	3.4	3.4	3.4
Burnup (MWD/MTU)	40,000	40,000	40,000	40,000
Cooling time (years)	5	5	5	5
Power/assembly (MW)	13.7	17.5	19.819	20.4
Specific power (MW/MTU)	31.275	39.083	40	42.503
Weight of UO ₂ (kg) [†]	496.887	507.9	562.029	544.428
Weight of U (kg) [†]	438.055	447.764	495.485	479.968
No. of Guide Tubes	5	5	17	25
Guide Tube O.D. (in.)	1.115	0.98	0.53	0.564
Guide Tube Thickness (in.)	0.0400	0.0400	0.0160	0.0175

[†] Derived from parameters in this table.

HOLTEC INTERNATIONAL COPYRIGHTED MATERIAL

HI-STORM FSAR
REPORT HI-2002444

Rev. 12

5.2-46

Table 5.2.26 (page 1 of 2)

DESCRIPTION OF EVALUATED ZIRCALOY CLAD BWR FUEL

Array Type	7x7	8x8	8x8	9x9	9x9
Fuel assembly array class	7x7B	8x8B	8x8CDE	9x9A	9x9B
Active fuel length (in.)	144	144	150	144	150
No. of fuel rods	49	64	62	74	72
Rod pitch (in.)	0.738	0.642	0.64	0.566	0.572
Cladding material	Zr-2	Zr-2	Zr-2	Zr-2	Zr-2
Rod diameter (in.)	0.570	0.484	0.493	0.44	0.433
Cladding thickness (in.)	0.0355	0.02725	0.034	0.028	0.026
Pellet diameter (in.)	0.488	0.4195	0.416	0.376	0.374
Pellet material	UO ₂	UO ₂	UO ₂	UO ₂	UO ₂
Pellet density (gm/cc) (% of theoretical)	10.412 (95%)	10.412 (95%)	10.412 (95%)	10.522 (96%)	10.522 (96%)
Enrichment (wt.% ²³⁵ U)	3.0	3.0	3.0	3.0	3.0
Burnup (MWD/MTU)	40,000	40,000	40,000	40,000	40,000
Cooling time (years)	5	5	5	5	5
Power/assembly (MW)	5.96	5.75	5.75	5.75	5.75
Specific power (MW/MTU)	30	30	30.24	31.97	31.88
Weight of UO ₂ (kg) [†]	225.177	217.336	215.673	204.006	204.569
Weight of U (kg) [†]	198.516	191.603	190.137	179.852	180.348
No. of Water Rods	0	0	2	2	1
Water Rod O.D. (in.)	n/a	n/a	0.493	0.98	1.516
Water Rod Thickness (in.)	n/a	n/a	0.034	0.03	0.0285

[†] Derived from parameters in this table.

HOLTEC INTERNATIONAL COPYRIGHTED MATERIAL

HI-STORM FSAR
REPORT HI-2002444

Rev. 12

5.2-47

Table 5.2.26 (page 1 of 2)

DESCRIPTION OF EVALUATED ZIRCALOY CLAD BWR FUEL

Array Type	9x9	9x9	9x9	10x10	10x10
Fuel assembly array class	9x9CD	9x9EF	9x9G	10x10AB	10x10C
Active fuel length (in.)	150	144	150	144	150
No. of fuel rods	80	76	72	92	96
Rod pitch (in.)	0.572	0.572	0.572	0.510	0.488
Cladding material	Zr-2	Zr-2	Zr-2	Zr-2	Zr-2
Rod diameter (in.)	0.423	0.443	0.424	0.404	0.378
Cladding thickness (in.)	0.0295	0.0285	0.03	0.0260	0.0243
Pellet diameter (in.)	0.3565	0.3745	0.3565	0.345	0.3224
Pellet material	UO ₂	UO ₂	UO ₂	UO ₂	UO ₂
Pellet density (gm/cc) (% of theoretical)	10.522 (96%)	10.522 (96%)	10.522 (96%)	10.522 (96%)	10.522 (96%)
Enrichment (wt.% ²³⁵ U)	3.0	3.0	3.0	3.0	3.0
Burnup (MWD/MTU)	40,000	40,000	40,000	40,000	40,000
Cooling time (years)	5	5	5	5	5
Power/assembly (MW)	5.75	5.75	5.75	5.75	5.75
Specific power (MW/MTU)	31.58	31.38	35.09	30.54	32.18
Weight of UO ₂ (kg) [†]	206.525	207.851	185.873	213.531	202.687
Weight of U (kg) [†]	182.073	183.242	163.865	188.249	178.689
No. of Water Rods	1	5	1	2	1
Water Rod O.D. (in.)	0.512	0.546	1.668	0.980	Note 1
Water Rod Thickness (in.)	0.02	0.0120	0.032	0.0300	Note 1

Note 1: 10x10C has a diamond shaped water rod with 4 additional segments dividing the fuel rods into four quadrants.

[†] Derived from parameters in this table.

HOLTEC INTERNATIONAL COPYRIGHTED MATERIAL

HI-STORM FSAR
REPORT HI-2002444

Rev. 12

5.2-48

Table 5.2.27

COMPARISON OF SOURCE TERMS FOR ZIRCALOY CLAD PWR FUEL
 3.4 wt.% ²³⁵U - 40,000 MWD/MTU - 5 years cooling

Assembly	WE 14x14	WE 14x14	WE 15x15	WE 17x17	WE 17x17	CE 14x14	CE 16x16	B&W 15x15	B&W 17x17
Array class	14x14A	14x14B	15x15 ABC	17x17A	17x17B	14x14C	16x16A	15x15 DEFHI	17x17C
Neutrons/sec	1.76E+8 1.78E+8	2.32E+8 2.35E+8	2.70E+8 2.73E+8	2.18E+8	2.68E+8	2.32E+8	2.38E+8	2.94E+8	2.68E+8
Photons/sec (0.45-3.0 MeV)	2.88E+15 2.93E+15	3.28E+15 3.32E+15	3.80E+15 3.86E+15	3.49E+15	3.85E+15	3.37E+15	3.57E+15	4.01E+15	3.89E+15
Thermal power (watts)	809.5 820.7	923.5 933.7	1073 1086	985.6	1090	946.6	1005	1137	1098

Note:

The WE 14x14 and WE 15x15 have both zircaloy and stainless steel guide tubes. The first value presented is for the assembly with zircaloy guide tubes and the second value is for the assembly with stainless steel guide tubes.

Table 5.2.28

COMPARISON OF SOURCE TERMS FOR ZIRCALOY CLAD BWR FUEL
 3.0 wt.% ²³⁵U - 40,000 MWD/MTU - 5 years cooling

Assembly	7x7	8x8	8x8	9x9	9x9	9x9	9x9	9x9	10x10	10x10
Array Class	7x7B	8x8B	8x8CDE	9x9A	9x9B	9x9CD	9x9EF	9x9G	10x10AB	10x10C
Neutrons/sec	1.33E+8	1.22E+8	1.22E+8	1.13E+8	1.06E+8	1.09E+8	1.24E+8	9.15E+7	1.24E+8	1.07E+8
Photons/sec (0.45-3.0 MeV)	1.55E+15	1.49E+15	1.48E+15	1.41E+15	1.40E+15	1.42E+15	1.45E+15	1.28E+15	1.48E+15	1.40E+15
Thermal power (watts)	435.5	417.3	414.2	394.2	389.8	395	405.8	356.9	413.5	389.2

HOLTEC INTERNATIONAL COPYRIGHTED MATERIAL

HI-STORM FSAR
 REPORT HI-2002444

Rev. 12

5.2-50

HI-STORM 100 FSAR, NON-PROPRIETARY
 REVISION 12
 MARCH 12, 2014

Table 5.2.29

COMPARISON OF CALCULATED DECAY HEATS FOR DESIGN BASIS FUEL
AND VALUES REPORTED IN THE
DOE CHARACTERISTICS DATABASE[†] FOR
30,000 MWD/MTU AND 5-YEAR COOLING

Fuel Assembly Class	Decay Heat from the DOE Database (watts/assembly)	Decay Heat from Source Term Calculations (watts/assembly)
PWR Fuel		
B&W 15x15	752.0	827.5
B&W 17x17	732.9	802.7
CE 16x16	653.7	734.3
CE 14x14	601.3	694.9
WE 17x17	742.5	795.4
WE 15x15	762.2	796.2
WE 14x14	649.6	682.9
BWR Fuel		
7x7	310.9	315.7
8x8	296.6	302.8
9x9	275.0	286.8

Notes:

1. The decay heat from the source term calculations is the maximum value calculated for that fuel assembly class.
2. The decay heat values from the database include contributions from in-core material (e.g. spacer grids).
3. Information on the 10x10 was not available in the DOE database. However, based on the results in Table 5.2.28, the actual decay heat values from the 10x10 would be very similar to the values shown above for the 8x8.
4. The enrichments used for the column labeled "Decay Heat from Source Term Calculations" were consistent with Table 5.2.24.

[†] Reference [5.2.7].

HOLTEC INTERNATIONAL COPYRIGHTED MATERIAL

Table 5.2.30

DESCRIPTION OF DESIGN BASIS BURNABLE POISON ROD ASSEMBLY
AND THIMBLE PLUG DEVICE

Region	BPRA	TPD
Upper End Fitting (kg of steel)	2.62	2.3
Upper End Fitting (kg of inconel)	0.42	0.42
Gas Plenum Spacer (kg of steel)	0.77488	1.71008
Gas Plenum Springs (kg of steel)	0.67512	1.48992
In-core (kg of steel)	13.2	N/A

HOLTEC INTERNATIONAL COPYRIGHTED MATERIAL

HI-STORM FSAR
REPORT HI-2002444

Rev. 12

5.2-52

Table 5.2.31

DESIGN BASIS COBALT-60 ACTIVITIES FOR BURNABLE POISON ROD
ASSEMBLIES AND THIMBLE PLUG DEVICES

Region	BPRA	TPD
Upper End Fitting (curies Co-60)	32.7	25.21
Gas Plenum Spacer (curies Co-60)	5.0	9.04
Gas Plenum Springs (curies Co-60)	8.9	15.75
In-core (curies Co-60)	848.4	N/A

HOLTEC INTERNATIONAL COPYRIGHTED MATERIAL

HI-STORM FSAR
REPORT HI-2002444

Rev. 12

Table 5.2.32

DESCRIPTION OF DESIGN BASIS CONTROL ROD ASSEMBLY
CONFIGURATIONS FOR SOURCE TERM CALCULATIONS

Axial Dimensions Relative to Bottom of Active Fuel			Flux Weighting Factor	Mass of cladding (kg Inconel)	Mass of absorber (kg AgInCd)
Start (in)	Finish (in)	Length (in)			
Configuration 1 - 10% Inserted					
0.0	15.0	15.0	1.0	1.32	7.27
15.0	18.8125	3.8125	0.2	0.34	1.85
18.8125	28.25	9.4375	0.1	0.83	4.57
Configuration 2 - Fully Removed					
0.0	3.8125	3.8125	0.2	0.34	1.85
3.8125	13.25	9.4375	0.1	0.83	4.57

HOLTEC INTERNATIONAL COPYRIGHTED MATERIAL

HI-STORM FSAR
REPORT HI-2002444

Rev. 12

Table 5.2.33

DESCRIPTION OF DESIGN BASIS AXIAL POWER SHAPING ROD
CONFIGURATION S FOR SOURCE TERM CALCULATIONS

Axial Dimensions Relative to Bottom of Active Fuel			Flux Weighting Factor	Mass of cladding (kg Steel)	Mass of absorber (kg Inconel)
Start (in)	Finish (in)	Length (in)			
Configuration 1 - 10% Inserted					
0.0	15.0	15.0	1.0	1.26	5.93
15.0	18.8125	3.8125	0.2	0.32	1.51
18.8125	28.25	9.4375	0.1	0.79	3.73
Configuration 2 - Fully Removed					
0.0	3.8125	3.8125	0.2	0.32	1.51
3.8125	13.25	9.4375	0.1	0.79	3.73
Configuration 3 - Fully Inserted					
0.0	63.0	63.0	1.0	5.29	24.89
63.0	66.8125	3.8125	0.2	0.32	1.51
66.8125	76.25	9.4375	0.1	0.79	3.73

HOLTEC INTERNATIONAL COPYRIGHTED MATERIAL

HI-STORM FSAR
REPORT HI-2002444

Rev. 12

5.2-55

Table 5.2.34

DESIGN BASIS SOURCE TERMS FOR CONTROL ROD
ASSEMBLY CONFIGURATIONS

Axial Dimensions Relative to Bottom of Active Fuel			Photons/sec from AgInCd			Curies Co-60 from Inconel
Start (in)	Finish (in)	Length (in)	0.3-0.45 MeV	0.45-0.7 MeV	0.7-1.0 MeV	
Configuration 1 - 10% Inserted - 80.8 watts decay heat						
0.0	15.0	15.0	1.91e+14	1.78e+14	1.42e+14	1111.38
15.0	18.8125	3.8125	9.71e+12	9.05e+12	7.20e+12	56.50
18.8125	28.25	9.4375	1.20e+13	1.12e+13	8.92e+12	69.92
Configuration 2 - Fully Removed - 8.25 watts decay heat						
0.0	3.8125	3.8125	9.71e+12	9.05e+12	7.20e+12	56.50
3.8125	13.25	9.4375	1.20e+13	1.12e+13	8.92e+12	69.92

HOLTEC INTERNATIONAL COPYRIGHTED MATERIAL

HI-STORM FSAR
REPORT HI-2002444

Rev. 12

5.2-56

Table 5.2.35

DESIGN BASIS SOURCE TERMS FROM AXIAL POWER
SHAPING ROD CONFIGURATIONS

Axial Dimensions Relative to Bottom of Active Fuel			Curies of Co-60
Start (in)	Finish (in)	Length (in)	
Configuration 1 - 10% Inserted - 46.2 watts decay heat			
0.0	15.0	15.0	2682.57
15.0	18.8125	3.8125	136.36
18.8125	28.25	9.4375	168.78
Configuration 2 - Fully Removed - 4.72 watts decay heat			
0.0	3.8125	3.8125	136.36
3.8125	13.25	9.4375	168.78
Configuration 3 - Fully Inserted - 178.9 watts decay heat			
0.0	63.0	63.0	11266.80
63.0	66.8125	3.8125	136.36
66.8125	76.25	9.4375	168.78

HOLTEC INTERNATIONAL COPYRIGHTED MATERIAL

HI-STORM FSAR
REPORT HI-2002444

Rev. 12

Table 5.2.36

DESCRIPTION OF FUEL ASSEMBLY USED TO ANNALYZE THORIA RODS IN THE THORIA ROD CANISTER

	BWR
Fuel type	8x8
Active fuel length (in.)	110.5
No. of UO ₂ fuel rods	55
No. of UO ₂ /ThO ₂ fuel rods	9
Rod pitch (in.)	0.523
Cladding material	zircaloy
Rod diameter (in.)	0.412
Cladding thickness (in.)	0.025
Pellet diameter (in.)	0.358
Pellet material	98.2% ThO ₂ and 1.8% UO ₂ for UO ₂ /ThO ₂ rods
Pellet density (gm/cc)	10.412
Enrichment (w/o ²³⁵ U)	93.5 in UO ₂ for UO ₂ /ThO ₂ rods and 1.8 for UO ₂ rods
Burnup (MWD/MTIHM)	16,000
Cooling Time (years)	18
Specific power (MW/MTIHM)	16.5
Weight of ThO ₂ and UO ₂ (kg) [†]	121.46
Weight of U (kg) [†]	92.29
Weight of Th (kg) [†]	14.74

[†] Derived from parameters in this table.

HOLTEC INTERNATIONAL COPYRIGHTED MATERIAL

Table 5.2.37

CALCULATED FUEL GAMMA SOURCE FOR THORIA ROD
CANISTER CONTAINING EIGHTEEN THORIA RODS

Lower Energy (MeV)	Upper Energy (MeV)	16,000 MWD/MTIHM 18-Year Cooling	
		(MeV/s)	(Photons/s)
4.5e-01	7.0e-01	3.07e+13	5.34e+13
7.0e-01	1.0	5.79e+11	6.81e+11
1.0	1.5	3.79e+11	3.03e+11
1.5	2.0	4.25e+10	2.43e+10
2.0	2.5	4.16e+8	1.85e+8
2.5	3.0	2.31e+11	8.39e+10
Totals		1.23e+12	1.09e+12

Table 5.2.38

CALCULATED FUEL NEUTRON SOURCE FOR THORIA ROD
CANISTER CONTAINING EIGHTEEN THORIA RODS

Lower Energy (MeV)	Upper Energy (MeV)	16,000 MWD/MTIHM 18-Year Cooling (Neutrons/s)
1.0e-01	4.0e-01	5.65e+2
4.0e-01	9.0e-01	3.19e+3
9.0e-01	1.4	6.79e+3
1.4	1.85	1.05e+4
1.85	3.0	3.68e+4
3.0	6.43	1.41e+4
6.43	20.0	1.60e+2
Totals		7.21e+4

5.3 MODEL SPECIFICATIONS

The shielding analysis of the HI-STORM 100 System was performed with MCNP-4A [5.1.1]. MCNP is a Monte Carlo transport code that offers a full three-dimensional combinatorial geometry modeling capability including such complex surfaces as cones and tori. This means that no gross approximations were required to represent the HI-STORM 100 System, including the HI-TRAC transfer casks, in the shielding analysis. A sample input file for MCNP is provided in Appendix 5.C.

As discussed in Section 5.1.1, off-normal conditions do not have any implications for the shielding analysis. Therefore, the MCNP models and results developed for the normal conditions also represent the off-normal conditions. Section 5.1.2 discussed the accident conditions and stated that the only accident that would impact the shielding analysis would be a loss of the neutron shield (water) in the HI-TRAC. Therefore, the MCNP model of the normal HI-TRAC condition has the neutron shield in place while the accident condition replaces the neutron shield with void. Section 5.1.2 also mentioned that there is no credible accident scenario that would impact the HI-STORM shielding analysis. Therefore, models and results for the normal and accident conditions are identical for the HI-STORM overpack.

5.3.1 Description of the Radial and Axial Shielding Configuration

Chapter 1 provides the drawings that describe the HI-STORM 100 System, including the HI-TRAC transfer casks. These drawings, using nominal dimensions, were used to create the MCNP models used in the radiation transport calculations. Modeling deviations from these drawings are discussed below. Figures 5.3.1 through 5.3.6 show cross sectional views of the HI-STORM 100 overpack and MPC as it was modeled in MCNP for each of the MPCs. Figures 5.3.1 through 5.3.3 were created with the MCNP two-dimensional plotter and are drawn to scale. The inlet and outlet vents were modeled explicitly, therefore, streaming through these components is accounted for in the calculations of the dose adjacent to the overpack and at 1 meter. Figure 5.3.7 shows a cross sectional view of the 100-ton HI-TRAC with the MPC-24 inside as it was modeled in MCNP. Since the fins and pocket trunnions were modeled explicitly, neutron streaming through these components is accounted for in the calculations of the dose adjacent to the overpack and 1 meter dose. In Section 5.4.1, the dose effect of localized streaming through these compartments is analyzed.

Figure 5.3.10 shows a cross sectional view of the HI-STORM 100 overpack with the as-modeled thickness of the various materials. The dimensions for the HI-STORM 100S and HI-STORM 100S Version B overpacks are also shown on Figure 5.3.10. This figure notes two different dimensions for the inner and outer shells. These values apply only to the HI-STORM 100 and 100S. In these overpacks, the inner and outer shells can be manufactured from 1.25 and 0.75 inch thick steel, respectively, or both shells can be manufactured from 1 inch thick steel. The HI-STORM 100 and 100S were modeled as 1.25 and 0.75 inch thick shells.

HOLTEC INTERNATIONAL COPYRIGHTED MATERIAL

HI-STORM FSAR
REPORT HI-2002444

Rev: 7

5.3-1

Figures 5.3.11, 5.3.18, and 5.3.22 are axial representations of the HI-STORM 100, HI-STORM 100S, and HI-STORM 100S Version B overpacks, respectively, with the various as-modeled dimensions indicated.

Only the HI-STORM 100S Version B is analyzed in this chapter. This is reasonable because the HI-STORM 100S Version B overpack is shorter than the other overpacks, and the MPC is positioned closer to the inlet vent which results in higher dose rates at the inlet vent compared to the other overpacks. In addition, the HI-STORM 100S Version B has slightly higher offsite dose than the other overpacks.

Figures 5.3.12, 5.3.13, and 5.3.23 show axial cross-sectional views of the 100-, 125-ton, and 100D HI-TRAC transfer casks, respectively, with the as-modeled dimensions and materials specified. Figures 5.3.14, 5.3.15, and 5.3.20 show fully labeled radial cross-sectional views of the HI-TRAC 100, 125, and 125D transfer casks, respectively. Figure 5.3.14 also provides the information for the HI-TRAC 100D. Finally, Figures 5.3.16 and 5.3.17 show fully labeled diagrams of the transfer lids for the HI-TRAC 100 and 125 transfer casks. Since lead plate may be used instead of poured lead in the pool and transfer lids, there exists the possibility of a gap between the lead plate and the surrounding steel walls. This gap was accounted for in the analysis as depicted on Figures 5.3.16 and 5.3.17. The gap was not modeled in the pool lid since the gap will only exist on the outer edges of the pool lid and the highest dose rate is in the center. (All results presented in this chapter were calculated with the gap with the exception of the results presented in Figures 5.1.6, 5.1.7, and 5.1.11 which did not include the gap.) The HI-TRAC 100D and 125D do not utilize the transfer lid, rather they utilize the pool lid in conjunction with the mating device. Therefore the dose rates reported for the pool lid in this chapter are applicable to both the HI-TRAC 125 and 125D and the HI-TRAC 100 and 100D while the dose rates reported for the transfer lid are applicable only to the HI-TRAC 100 and 125. Consistent with the analysis of the transfer lid in which only the portion of the lid directly below the MPC was modeled, the structure of the mating device which surrounds the pool lid was not modeled.

Since the HI-TRAC 125D has fewer radial ribs, the dose rate at the midplane of the HI-TRAC 125D is higher than the dose rate at the midplane of the HI-TRAC 125. The HI-TRAC 125D has steel ribs in the lower water jacket while the HI-TRAC 125 does not. These additional ribs in the lower water jacket reduce the dose rate in the vicinity of the pool lid for the HI-TRAC 125D compared to the HI-TRAC 125. Since the dose rates at the midplane of the HI-TRAC 125D are higher than the HI-TRAC 125, the results on the radial surface are only presented for the HI-TRAC 125D in this chapter.

To reduce the gamma dose around the inlet and outlet vents, stainless steel cross plates, designated gamma shield cross plates[†] (see Figures 5.3.11 and 5.3.18), have been installed inside

[†] This design embodiment, formally referred to as "Duct Photon Attenuator," has been disclosed as an invention by Holtec International for consideration by the US Patent Office for issuance of a patent under U.S. law.

all vents in all overpacks. The steel in these plates effectively attenuates the fuel and ^{60}Co gammas that dominated the dose at these locations prior to their installation. Figure 5.3.19 shows three designs for the gamma shield cross plates to be used in the inlet and outlet vents. The designs in the top portion of the figure are mandatory for use in the HI-STORM 100 and 100S overpacks during normal storage operations and were assumed to be in place in the shielding analysis. The designs in the middle portion of the figure may be used instead of the mandatory designs in the HI-STORM 100S overpack to further reduce the radiation dose rates at the vents. These optional gamma shield cross plates could further reduce the dose rate at the vent openings by as much as a factor of two. The designs in the bottom portion of the figure are mandatory for use in the HI-STORM 100S Version B overpack during normal storage operations and were assumed to be in place in the shielding analysis.

Calculations were performed to determine the acceptability of homogenizing the fuel assembly versus explicit modeling. Based on these calculations it was concluded that it was acceptable to homogenize the fuel assembly without loss of accuracy. The width of the PWR and BWR homogenized fuel assembly is equal to 15 times the pitch and 7 times the pitch, respectively. Homogenization resulted in a noticeable decrease in run time.

Several conservative approximations were made in modeling the MPC. The conservative approximations are listed below.

1. The basket material in the top and bottom 0.9 inches where the MPC basket flow holes are located is not modeled. The length of the basket not modeled (0.9 inches) was determined by calculating the equivalent area removed by the flow holes. This method of approximation is conservative because no material for the basket shielding is provided in the 0.9-inch area at the top and bottom of the MPC basket.
2. The upper and lower fuel spacers are not modeled, as the fuel spacers are not needed on all fuel assembly types. However, most PWR fuel assemblies will have upper and lower fuel spacers. The fuel spacer length for the design basis fuel assembly type determines the positioning of the fuel assembly for the shielding analysis, but the fuel spacer materials are not modeled. This is conservative since it removes steel that would provide a small amount of additional shielding.
3. For the MPC-32, MPC-24, and MPC-68, the MPC basket supports are not modeled. This is conservative since it removes steel that would provide a small increase in shielding. The optional aluminum heat conduction elements are also conservatively not modeled.
4. The MPC-24 basket is fabricated from 5/16 inch thick cell plates. It is conservatively assumed for modeling purposes that the structural portion of the MPC-24 basket is uniformly fabricated from 9/32 inch thick steel. The Boral and

HOLTEC INTERNATIONAL COPYRIGHTED MATERIAL

HI-STORM FSAR
REPORT HI-2002444

Rev. 7

5.3-3

sheathing are modeled explicitly. This is conservative since it removes steel that would provide a small amount of additional shielding.

5. In the modeling of the BWR fuel assemblies, the zircaloy flow channels were not represented. This was done because it cannot be guaranteed that all BWR fuel assemblies will have an associated flow channel when placed in the MPC. The flow channel does not contribute to the source, but does provide some small amount of shielding. However, no credit is taken for this additional shielding.
6. In the MPC-24, conservatively, all Boral panels on the periphery were modeled with a reduced width of 5 inches compared to 6.25 inches or 7.5 inches.
7. The MPC-68 is designed for two lid thicknesses: 9.5 inches and 10 inches. Conservatively, all calculations reported in this chapter were performed with the 9.5 inch thick lid.

During this project several design changes occurred that affected the drawings, but did not significantly affect the MCNP models of the HI-STORM 100 and HI-TRAC. Therefore, the models do not exactly represent the drawings. The discrepancies between models and drawings are listed and discussed here.

MPC Modeling Discrepancies

1. In the MPCs, there is a sump in the baseplate to enhance draining of the MPC. This localized reduction in the thickness of the baseplate was not modeled. Since there is significant shielding and distance in both the HI-TRAC and the HI-STORM outside the MPC baseplate, this localized reduction in shielding will not affect the calculated dose rates outside the HI-TRAC or the HI-STORM.
2. The design configuration of the MPC-24 has been enhanced for criticality purposes. The general location of the 24 assemblies remains basically the same, therefore the shielding analysis continues to use the superseded configuration. Since the new MPC-24 configuration and the configuration of the MPC-24E are almost identical, the analysis of the earlier MPC-24 configuration is valid for the MPC-24E as well. Figure 5.3.21 shows the superseded and current configuration for the MPC-24 for comparison.
3. The sheathing thickness on the new MPC-24 configuration was reduced from 0.06 inches to 0.0235 inches. However, the model still uses 0.06 inches. This discrepancy is compensated for by the use of 9/32 inch cell walls and 5 inch boral on the periphery as described above. MCNP calculations were performed with the new MPC-24 configuration in the 100-ton HI-TRAC for comparison to the superseded configuration. These results indicate that on the side of the overpack, the dose rates decrease by approximately 12% on the surface for a burnup of

HOLTEC INTERNATIONAL COPYRIGHTED MATERIAL

HI-STORM FSAR
REPORT HI-2002444

Rev. 7

5.3-4

60,000 MWD/MTU and a cooling time of 3 years. These results demonstrate that using the superceded MPC-24 design is conservative.

4. The MPC lid can be made either entirely from stainless steel, or from a stainless steel / carbon steel combination. In MCNP, the lid is modeled entirely as stainless steel. The difference in material would have a negligible effect on dose rates.

HI-TRAC Modeling Discrepancies

1. The pocket trunnion on the HI-TRAC 125 was modeled as penetrating the lead. This is conservative for gamma dose rates as it reduces effective shielding thickness. The HI-TRAC 125D does not use pocket trunnions.
2. The lifting blocks in the top lid of the 125-ton HI-TRACs were not modeled. Holtite-A was modeled instead. This is a small, localized item and will not impact the dose rates.
3. The door side plates that are in the middle of the transfer lid of the HI-TRAC 125 are not modeled. This is acceptable because the dose location calculated on the bottom of the transfer lid is in the center.
4. The outside diameter of the Holtite-A portion of the top lid of the 125-ton HI-TRACs was modeled as 4 inches larger than it is due to a design enhancement. This is acceptable because the peak dose rates on the top lid occur on the inner portions of the lid.

HI-STORM Modeling Discrepancies

1. The steel channels in the cavity between the MPC and overpack were not modeled. This is conservative since it removes steel that would provide a small amount of additional shielding.
2. The bolt anchor blocks were not explicitly modeled. Concrete was used instead. These are small, localized items and will not impact the dose rates.
3. In the HI-STORM 100S model, the exit vents were modeled as being inline with the inlet vents. In practice, they are rotated 45 degrees and positioned above the short radial plates. Therefore, this modeling change has the exit vents positioned above the full length radial plates. This modeling change has minimal impact on the dose rates at the exit vents.
4. The short radial plates in the HI-STORM 100S overpack were modeled in MCNP even though they are optional.

HOLTEC INTERNATIONAL COPYRIGHTED MATERIAL

HI-STORM FSAR
REPORT HI-2002444

Rev. 7

5.3-5

5. The pedestal baseplate, which is steel with holes for pouring concrete, in the HI-STORM 100 and 100S overpacks was modeled as concrete rather than steel. This is acceptable because this piece of steel is positioned at the bottom of the pedestal below 5 inches of steel and a minimum of 11.5 inches of concrete and therefore will have no impact on the dose rates at the bottom vent.
6. Minor penetrations in the body of the overpack (e.g. holes for grounding straps) are not modeled as these are small localized effects which will not affect the off-site dose rates.
7. Deleted
8. The drawings in Section 1.5 indicate that the HI-STORM 100S has a variable height. This is achieved by adjusting the height of the body of the overpack. The pedestal height is not adjusted. Conservatively, all calculations in this chapter used the shorter height for the HI-STORM 100S.
9. In February 2002, the top plate on the HI-STORM 100 overpack was modified to be two pieces in a shear ring arrangement. The total thickness of the top plate was not changed. However, there is approximately a 0.5 inch gap between the two pieces of the top plate. This gap was not modeled in MCNP since it will result in a small increase in the dose rate on the overpack lid in an area where the dose rate is greatly reduced compared to other locations on the lid.
10. The MPC base support in the HI-STORM 100S Version B was conservatively modeled as a 1 inch thick plate resting on a two inch tall ring as shown in Figure 5.3.22. The design of the overpack utilizes a solid three inch plate.
11. The gussets in the inside lower corners of the HI-STORM 100S Version B overpack were not modeled. Concrete was modeled instead.

5.3.1.1 Fuel Configuration

As described earlier, the active fuel region is modeled as a homogenous zone. The end fittings and the plenum regions are also modeled as homogenous regions of steel. The masses of steel used in these regions are shown in Table 5.2.1. The axial description of the design basis fuel assemblies is provided in Table 5.3.1. Figures 5.3.8 and 5.3.9 graphically depict the location of the PWR and BWR fuel assemblies within the HI-STORM 100 System. The axial locations of the Boral, basket, inlet vents, and outlet vents are shown in these figures.

5.3.1.2 Streaming Considerations

The MCNP model of the HI-STORM overpack completely describes the inlet and outlet vents, thereby properly accounting for their streaming effect. The gamma shield cross plates located in the inlet and outlet vents, which effectively reduce the gamma dose in these locations, are modeled explicitly.

The MCNP model of the HI-TRAC transfer cask describes the lifting trunnions, pocket trunnions, and the opening in the HI-TRAC top lid. The fins through the HI-TRAC water jacket are also modeled. Streaming considerations through these trunnions and fins are discussed in Section 5.4.1.

The design of the HI-STORM 100 System, as described in the drawings in Chapter 1, has eliminated all other possible streaming paths. Therefore, the MCNP model does not represent any additional streaming paths. A brief justification of this assumption is provided for each penetration.

- The lifting trunnions will remain installed in the HI-TRAC transfer cask.
- The pocket trunnions of the HI-TRAC are modeled as solid blocks of steel. No credit is taken for any part of the pocket trunnion that extends beyond the water jacket.
- The threaded holes in the MPC lid are plugged with solid plugs during storage and, therefore, do not create a void in the MPC lid.
- The drain and vent ports in the MPC lid are designed to eliminate streaming paths. The holes in the vent and drain port cover plates are filled with a set screw and plug weld. The steel lost in the MPC lid at the port location is replaced with a block of steel approximately 6 inches thick located directly below the port opening and attached to the underside of the lid. This design feature is shown on the drawings in Chapter 1. The MCNP model did not explicitly represent this arrangement but, rather, modeled the MPC lid as a solid plate.

5.3.2 Regional Densities

Composition and densities of the various materials used in the HI-STORM 100 System and HI-TRAC shielding analyses are given in Tables 5.3.2 and 5.3.3. All of the materials and their actual geometries are represented in the MCNP model.

The concrete density shown in Table 5.3.2 is the minimum concrete density analyzed in this chapter. The HI-STORM 100 overpacks are designed in such a way that the concrete density in the body of the overpack can be increased to approximately 3.2 gm/cc (200 lb/cu-ft). It is generally recommended to use concrete with a density of 155 lb/cu-ft or more. Increasing the density beyond this value would result in a significant reduction in the dose rates. This may be

HOLTEC INTERNATIONAL COPYRIGHTED MATERIAL

beneficial based on on-site and off-site ALARA considerations. Lower densities may be necessary to address weight restrictions at certain sites.

The water density inside the MPC corresponds to the maximum allowable water temperature within the MPC. The water density in the water jacket corresponds to the maximum allowable temperature at the maximum allowable pressure. As mentioned, the HI-TRAC transfer cask is equipped with a water jacket providing radial neutron shielding. Demineralized water will be utilized in the water jacket. To ensure operability for low temperature conditions, ethylene glycol (25% in solution) may be added to reduce the freezing point for low temperature operations. Calculations were performed to determine the effect of the ethylene glycol on the shielding effectiveness of the radial neutron shield. Based on these calculations, it was concluded that the addition of ethylene glycol (25% in solution) does not reduce the shielding effectiveness of the radial neutron shield.

The MPCs in the HI-STORM 100 System can be manufactured with one of two possible neutron absorbing materials: Boral or Metamic. Both materials are made of aluminum and B₄C powder. The Boral contains an aluminum and B₄C powder mixture sandwiched between two aluminum plates while the Metamic is a single plate. The minimum ¹⁰B areal density is the same for Boral and Metamic while the thicknesses are essentially the same. Therefore, the mass of Aluminum and B₄C are essentially equivalent and there is no distinction between the two materials from a shielding perspective. As a result, Table 5.3.2 identifies the composition for Boral and no explicit calculations were performed with Metamic.

Sections 4.4 and 4.5 demonstrate that all materials used in the HI-STORM and HI-TRAC remain below their design temperatures as specified in Table 2.2.3 during all normal conditions. Therefore, the shielding analysis does not address changes in the material density or composition as a result of temperature changes.

Section 4.4 indicates that there are localized areas in the concrete in the lid of the overpack which approach 390°F. An increase in temperature from 300°F to 390°F results in an approximate 0.666% overall density reduction due to the loss of chemically unbound water. This density reduction results in a reduction in the mass fraction of hydrogen from 0.6% to 0.529% in the area affected by the temperature excursion. This is a localized effect with the maximum loss occurring at the bottom center of the lid where the temperature is the hottest and reduced loss occurring as the temperature decreases to 300°F.

Based on these considerations, the presence of localized temperatures up to 390°F in the lid concrete has a negligible effect on the shielding effectiveness of the HI-STORM 100 overpack lid.

Chapter 11 discusses the effect of the various accident conditions on the temperatures of the shielding materials and the resultant impact on their shielding effectiveness. As stated in Section 5.1.2, there is only one accident that has any significant impact on the shielding configuration. This accident is the loss of the neutron shield (water) in the HI-TRAC as a result of fire or other

damage. The change in the neutron shield was conservatively analyzed by assuming that the entire volume of the liquid neutron shield was replaced by void.

HOLTEC INTERNATIONAL COPYRIGHTED MATERIAL

HI-STORM FSAR
REPORT HI-2002444

Rev. 7

5.3-9

HI-STORM 100 FSAR, NON-PROPRIETARY
REVISION 12
MARCH 12, 2014

Table 5.3.1

DESCRIPTION OF THE AXIAL MCNP MODEL OF THE FUEL ASSEMBLIES[†]

Region	Start (in.)	Finish (in.)	Length (in.)	Actual Material	Modeled Material
PWR					
Lower End Fitting	0.0	7.375	7.375	SS304	SS304
Space	7.375	8.375	1.0	zircaloy	void
Fuel	8.375	152.375	144	fuel & zircaloy	fuel
Gas Plenum Springs	152.375	156.1875	3.8125	SS304 & zircaloy	SS304
Gas Plenum Spacer	156.1875	160.5625	4.375	SS304 & zircaloy	SS304
Upper End Fitting	160.5625	165.625	5.0625	SS304	SS304
BWR					
Lower End Fitting	0.0	7.385	7.385	SS304	SS304
Fuel	7.385	151.385	144	fuel & zircaloy	fuel
Space	151.385	157.385	6	zircaloy	void
Gas Plenum Springs	157.385	166.865	9.48	SS304 & zircaloy	SS304
Expansion Springs	166.865	168.215	1.35	SS304	SS304
Upper End Fitting	168.215	171.555	3.34	SS304	SS304
Handle	171.555	176	4.445	SS304	SS304

[†] All dimensions start at the bottom of the fuel assembly. The length of the lower fuel spacer must be added to the distances to determine the distance from the top of the MPC baseplate.

HOLTEC INTERNATIONAL COPYRIGHTED MATERIAL

HI-STORM FSAR
REPORT HI-2002444

Rev. 7

5.3-10

Table 5.3.2

COMPOSITION OF THE MATERIALS IN THE HI-STORM 100 SYSTEM

Component	Density (g/cm ³)	Elements	Mass Fraction (%)
Uranium Oxide	10.412	²³⁵ U	2.9971(BWR) 3.2615(PWR)
		²³⁸ U	85.1529(BWR) 84.8885(PWR)
		O	11.85
Boral [†]	2.644	¹⁰ B	4.4226 (MPC-68 and MPC-32 in HI-STORM & HI-TRAC; MPC-24 in HI-STORM)4.367 (MPC-24 in HI-TRAC)
		¹¹ B	20.1474 (MPC-68 and MPC-32 in HI-STORM & HI-TRAC; MPC-24 in HI-STORM) 19.893 (MPC-24 in HI-TRAC)
		Al	68.61 (MPC-68 and MPC-32 in HI-STORM & HI-TRAC; MPC-24 in HI-STORM) 69.01 (MPC-24 in HI-TRAC)
		C	6.82 (MPC-68 and MPC-32 in HI-STORM & HI-TRAC; MPC-24 in HI-STORM) 6.73 (MPC-24 in HI-TRAC)
SS304	7.92	Cr	19
		Mn	2
		Fe	69.5
		Ni	9.5
Carbon Steel	7.82	C	0.5
		Fe	99.5
Zircaloy	6.55	Zr	100

[†] All B-10 loadings in the Boral compositions are conservatively lower than the values defined in the Bill of Materials.

HOLTEC INTERNATIONAL COPYRIGHTED MATERIAL

HI-STORM FSAR
REPORT HI-2002444

Rev. 7

5.3-11

Table 5.3.2 (continued)

COMPOSITION OF THE MATERIALS IN THE HI-STORM 100 SYSTEM

Component	Density (g/cm ³)	Elements	Mass Fraction (%)
Neutron Shield Holtite-A	1.61	C	27.66039
		H	5.92
		Al	21.285
		N	1.98
		O	42.372
		¹⁰ B	0.14087
		¹¹ B	0.64174
BWR Fuel Region Mixture	4.29251	²³⁵ U	2.4966
		²³⁸ U	70.9315
		O	9.8709
		Zr	16.4046
		N	8.35E-05
		Cr	0.0167
		Fe	0.0209
		Sn	0.2505
PWR Fuel Region Mixture	3.869939	²³⁵ U	2.7652
		²³⁸ U	71.9715
		O	10.0469
		Zr	14.9015
		Cr	0.0198
		Fe	0.0365
		Sn	0.2587

HOLTEC INTERNATIONAL COPYRIGHTED MATERIAL

HI-STORM FSAR
REPORT HI-2002444

Rev. 7

5.3-12

Table 5.3.2 (continued)

COMPOSITION OF THE MATERIALS IN THE HI-STORM 100 SYSTEM

Component	Density (g/cm ³)	Elements	Mass Fraction (%)
Lower End Fitting (PWR)	1.0783	SS304	100
Gas Plenum Springs (PWR)	0.1591	SS304	100
Gas Plenum Spacer (PWR)	0.1591	SS304	100
Upper End Fitting (PWR)	1.5410	SS304	100
Lower End Fitting (BWR)	1.4862	SS304	100
Gas Plenum Springs (BWR)	0.2653	SS304	100
Expansion Springs (BWR)	0.6775	SS304	100
Upper End Fitting (BWR)	1.3692	SS304	100
Handle (BWR)	0.2572	SS304	100
Lead	11.3	Pb	99.9
		Cu	0.08
		Ag	0.02
Water	0.9140 (water jacket)	H	11.2
	0.9619 (inside MPC)	O	88.8

HOLTEC INTERNATIONAL COPYRIGHTED MATERIAL

HI-STORM FSAR
REPORT HI-2002444

Rev. 7

Table 5.3.2 (continued)

COMPOSITION OF THE MATERIALS IN THE HI-STORM 100 SYSTEM

Component	Density (g/cm ³)	Elements	Mass Fraction (%)
Concrete	2.24	H	0.6
		O	50.0
		Si	31.5
		Al	4.8
		Na	1.7
		Ca	8.3
		Fe	1.2
		K	1.9

Table 5.3.3

COMPOSITION OF THE FUEL PELLETS IN THE MIXED OXIDE FUEL ASSEMBLIES

Component	Density (g/cm ³)	Elements	Mass Fraction (%)
Mixed Oxide Pellets	10.412	²³⁸ U	85.498
		²³⁵ U	0.612
		²³⁸ Pu	0.421
		²³⁹ Pu	1.455
		²⁴⁰ Pu	0.034
		²⁴¹ Pu	0.123
		²⁴² Pu	0.007
		O	11.85
Uranium Oxide Pellets	10.412	²³⁸ U	86.175
		²³⁵ U	1.975
		O	11.85

HOLTEC INTERNATIONAL COPYRIGHTED MATERIAL

HI-STORM FSAR
REPORT HI-2002444

Rev. 7

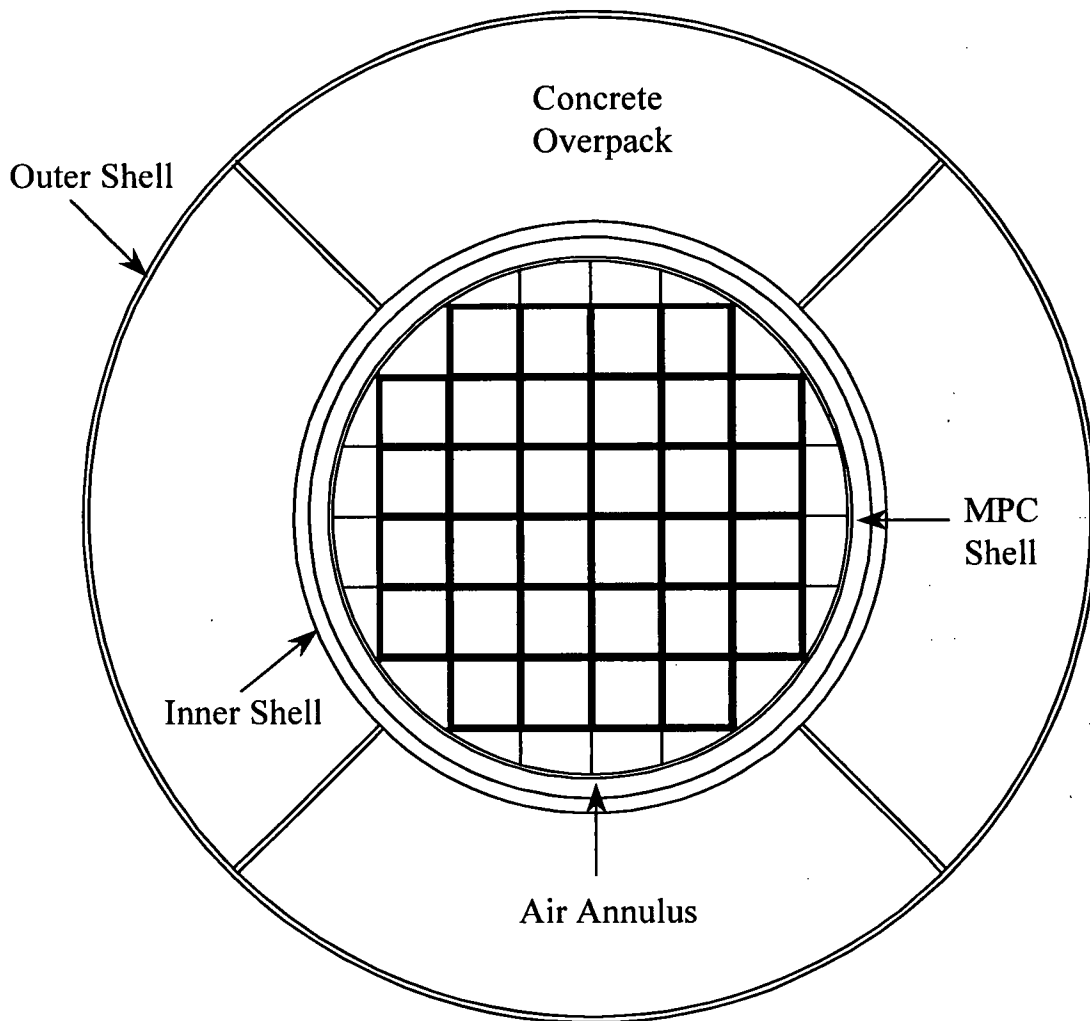


FIGURE 5.3.1; HI-STORM 100 OVERPACK WITH MPC-32 CROSS SECTIONAL VIEW AS MODELLED IN MCNP†

† This figure is drawn to scale using the MCNP plotter.

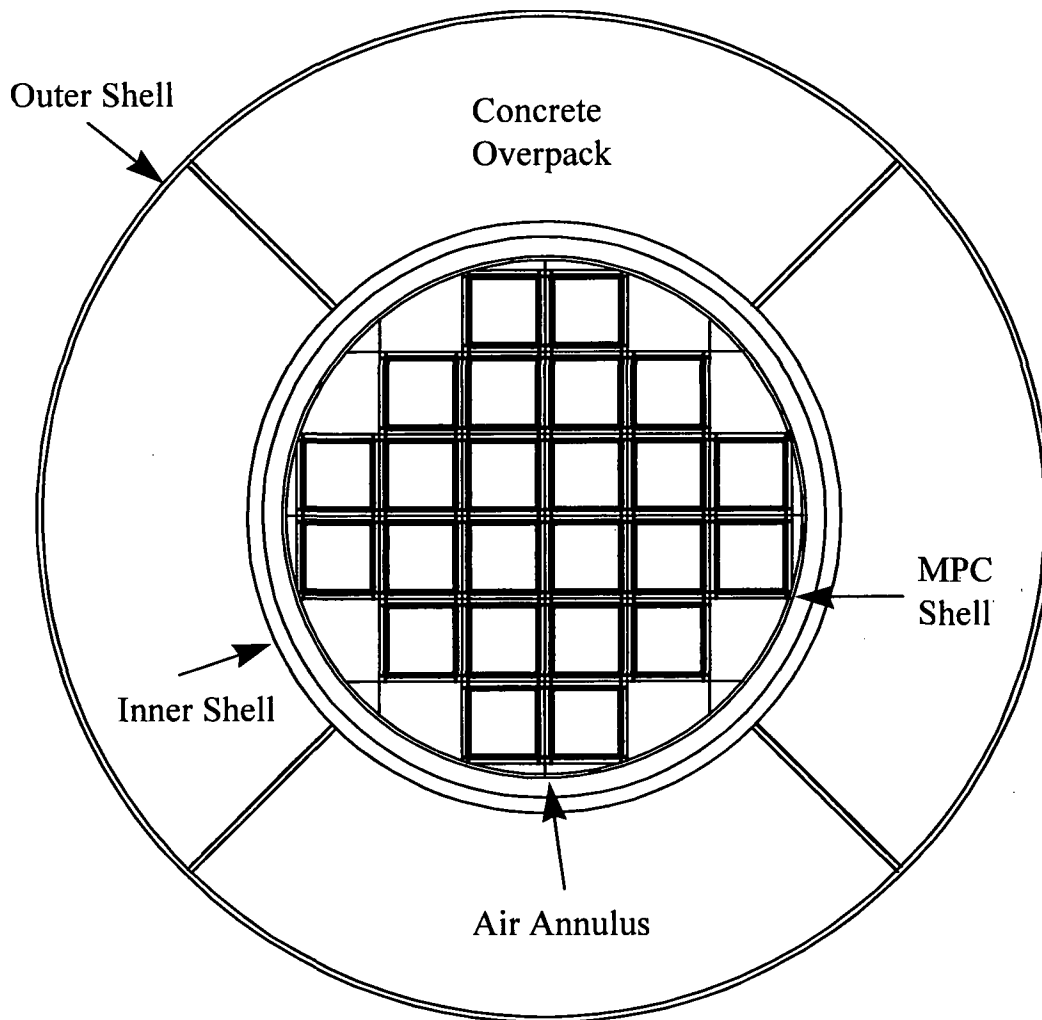


FIGURE 5.3.2; HI-STORM 100 OVERPACK WITH MPC-24 CROSS SECTIONAL VIEW AS MODELLED IN MCNP[†]

[†] This figure is drawn to scale using the MCNP plotter.

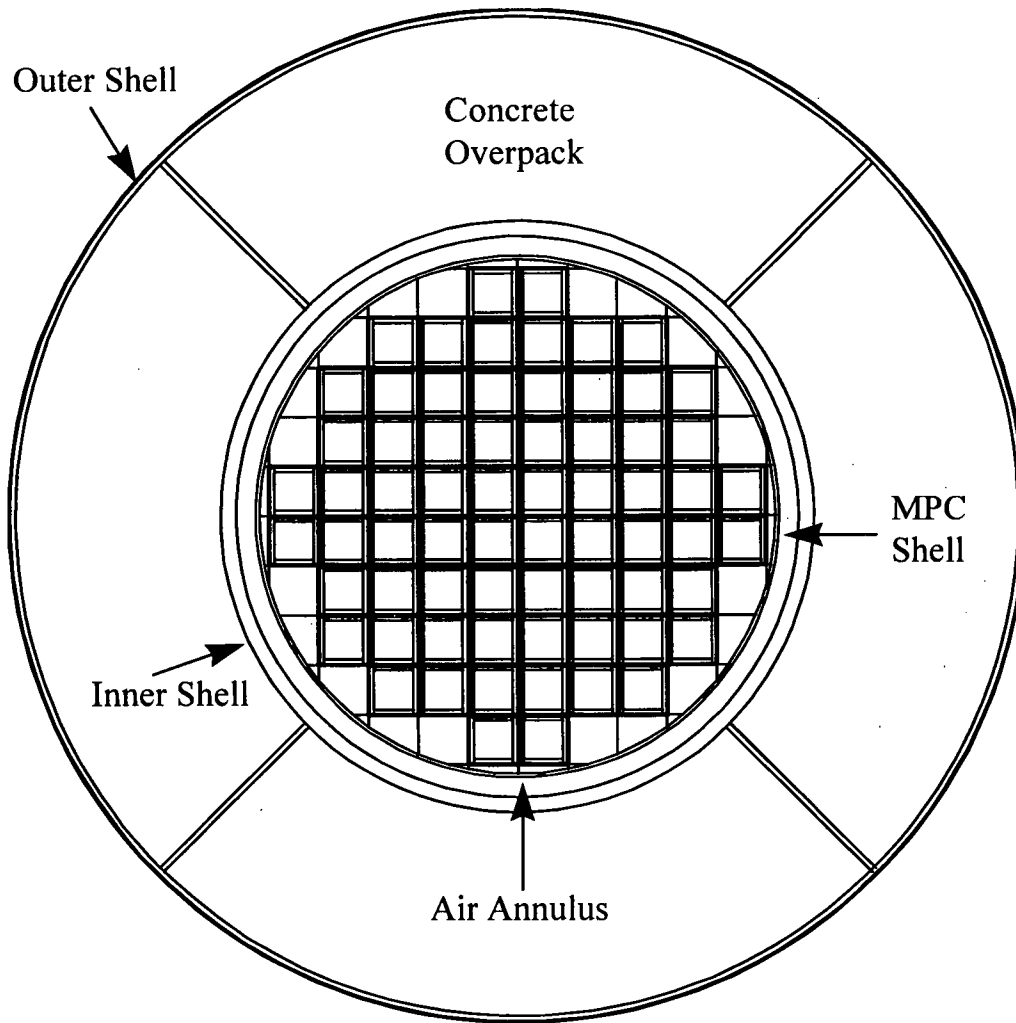


FIGURE 5.3.3; HI-STORM 100 OVERPACK WITH MPC-68 CROSS SECTIONAL VIEW AS MODELLED IN MCNP[†]

[†] This figure is drawn to scale using the MCNP plotter.

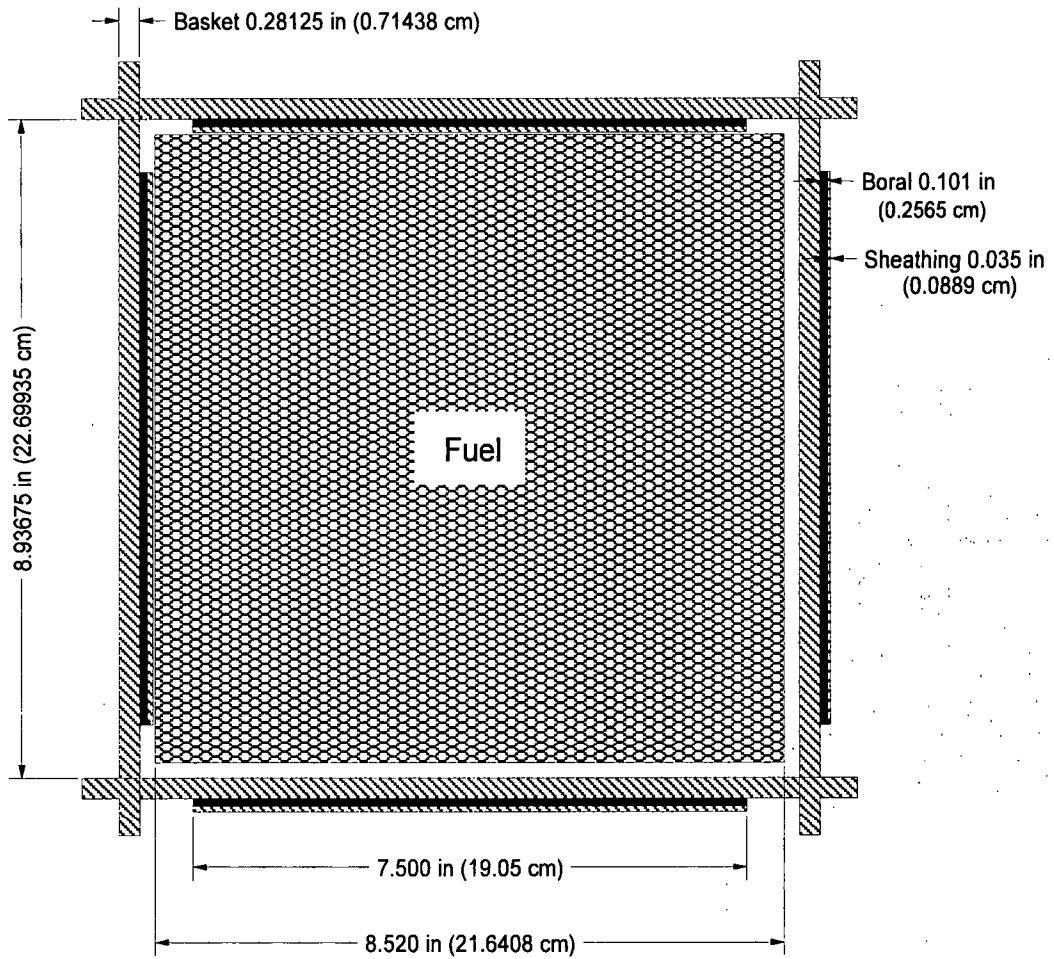


FIGURE 5.3.4; CROSS SECTIONAL VIEW OF AN MPC-32 BASKET CELL AS MODELED IN MCNP

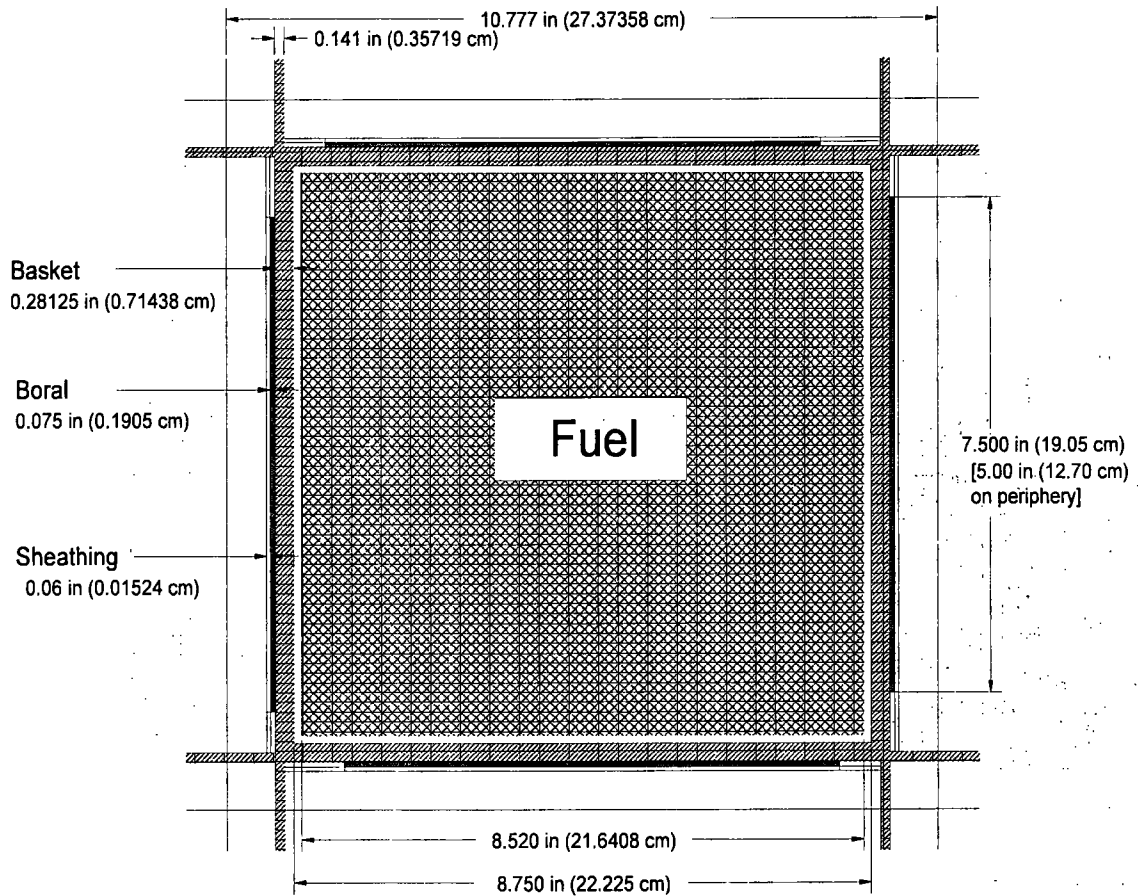


FIGURE 5.3.5; CROSS SECTIONAL VIEW OF AN MPC-24 BASKET CELL AS MODELED IN MCNP

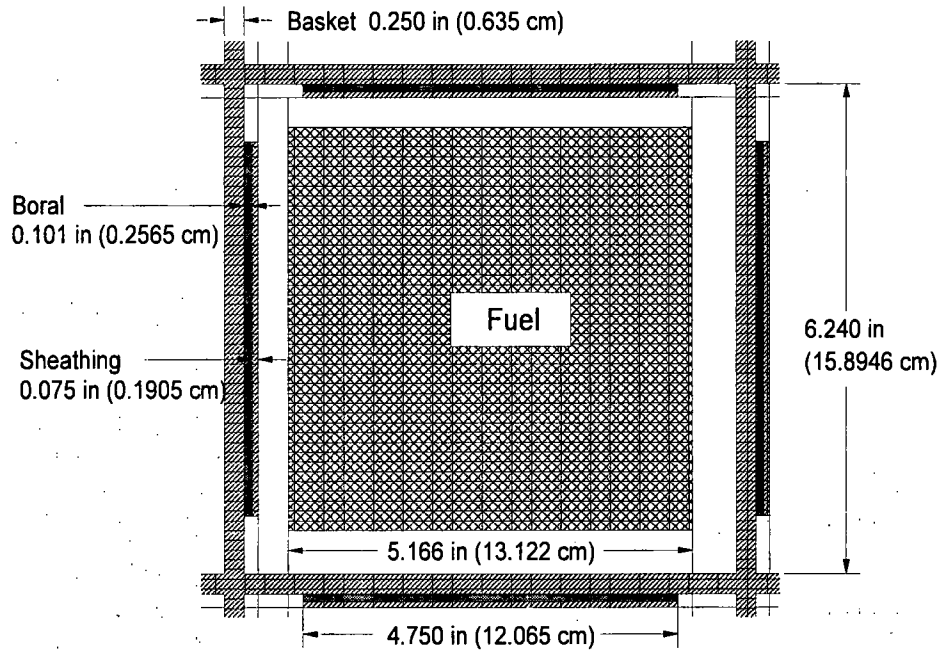


FIGURE 5.3.6; CROSS SECTIONAL VIEW OF AN MPC-68 BASKET CELL AS MODELED IN MCNP

100 TON HI-TRAC

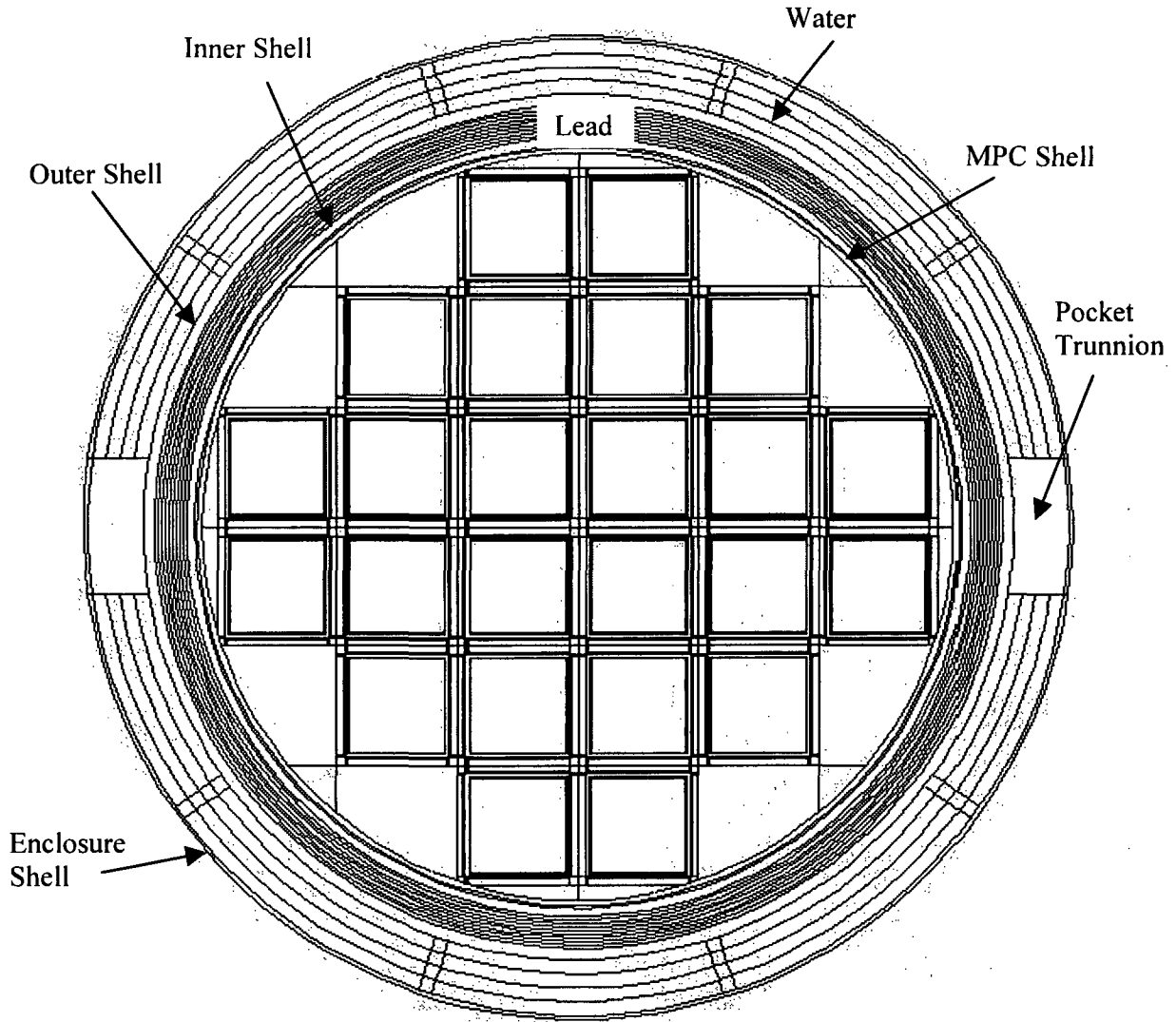


FIGURE 5.3.7; HI-TRAC OVERPACK WITH MPC-24 CROSS SECTIONAL VIEW AS MODELED IN MCNP[†]

[†] This figure is drawn to scale using the MCNP plotter.

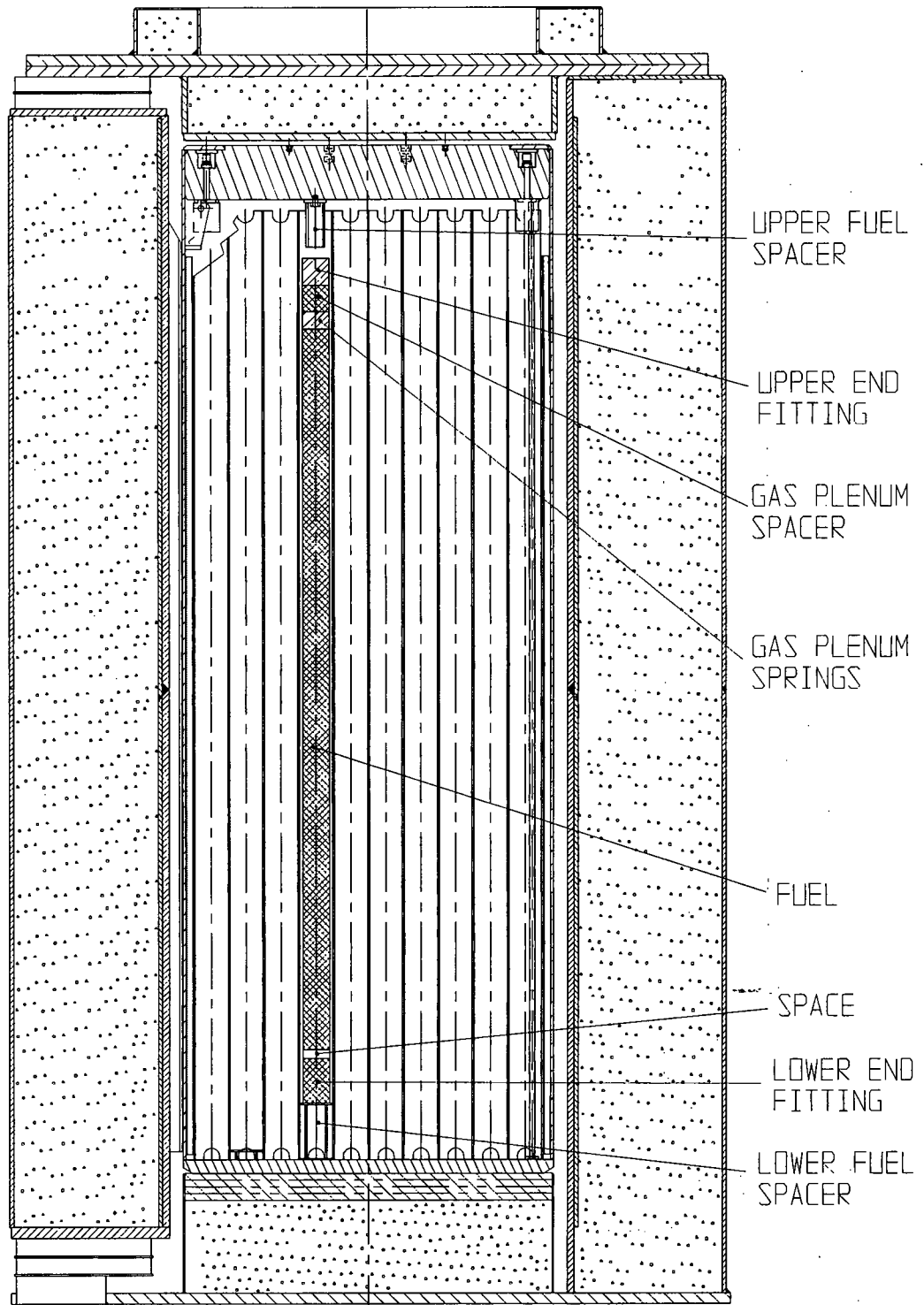


FIGURE 5.3.8; AXIAL LOCATION OF PWR DESIGN BASIS FUEL IN THE HI-STORM OVERPACK

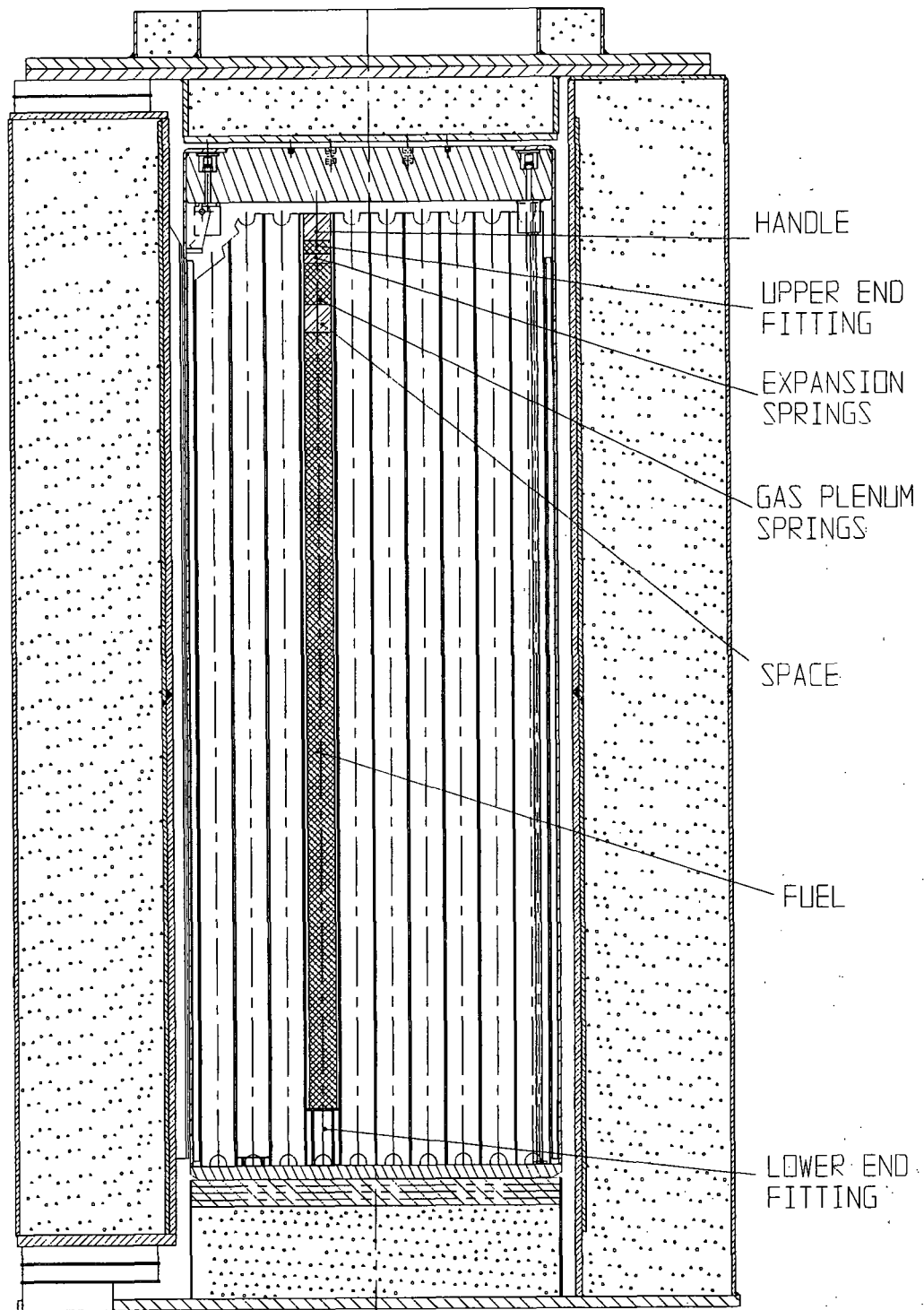


FIGURE 5.3.9; AXIAL LOCATION OF BWR DESIGN BASIS FUEL IN THE HI-STORM OVERPACK

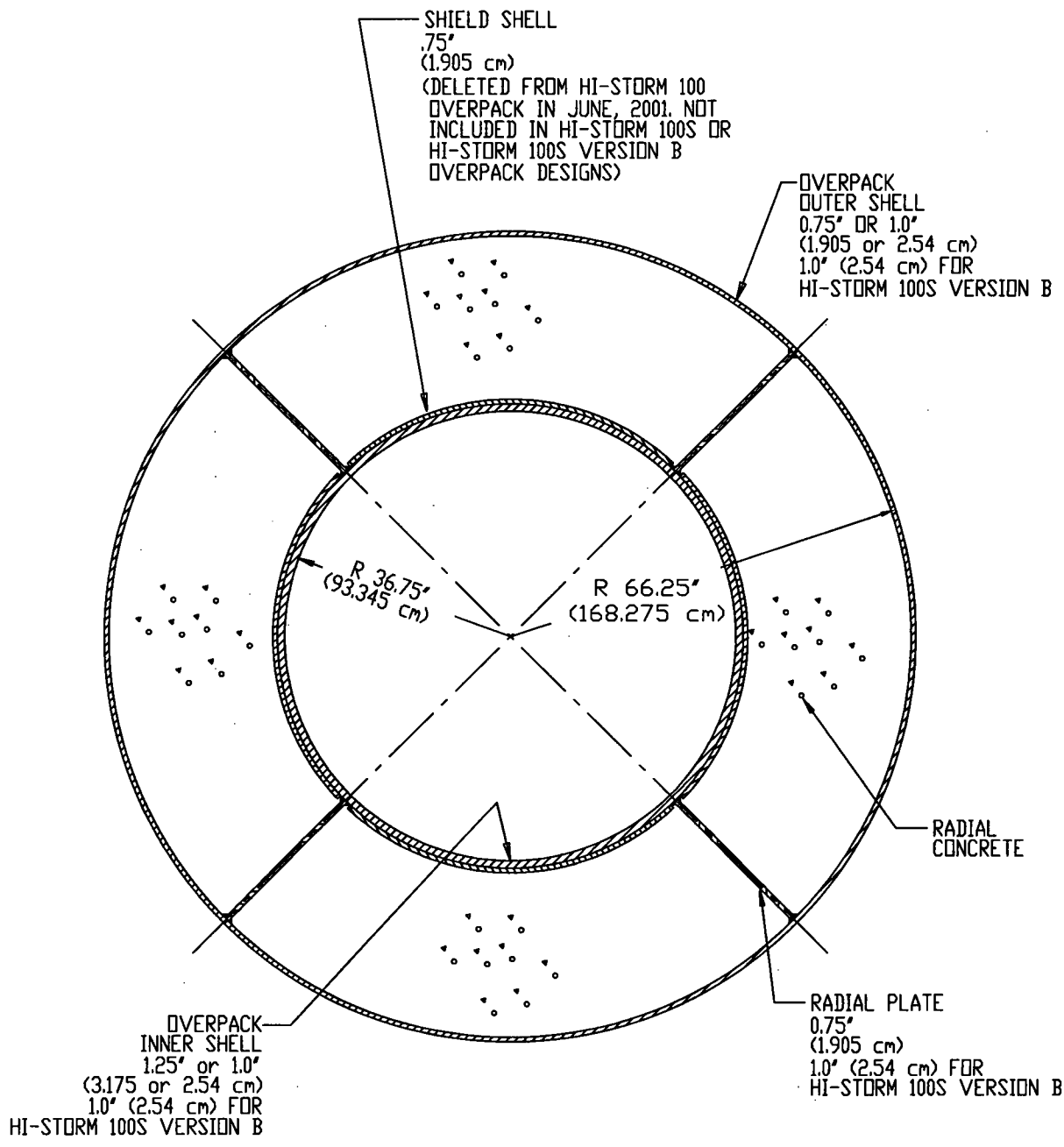


FIGURE 5.3.10; CROSS SECTION OF HI-STORM OVERPACK

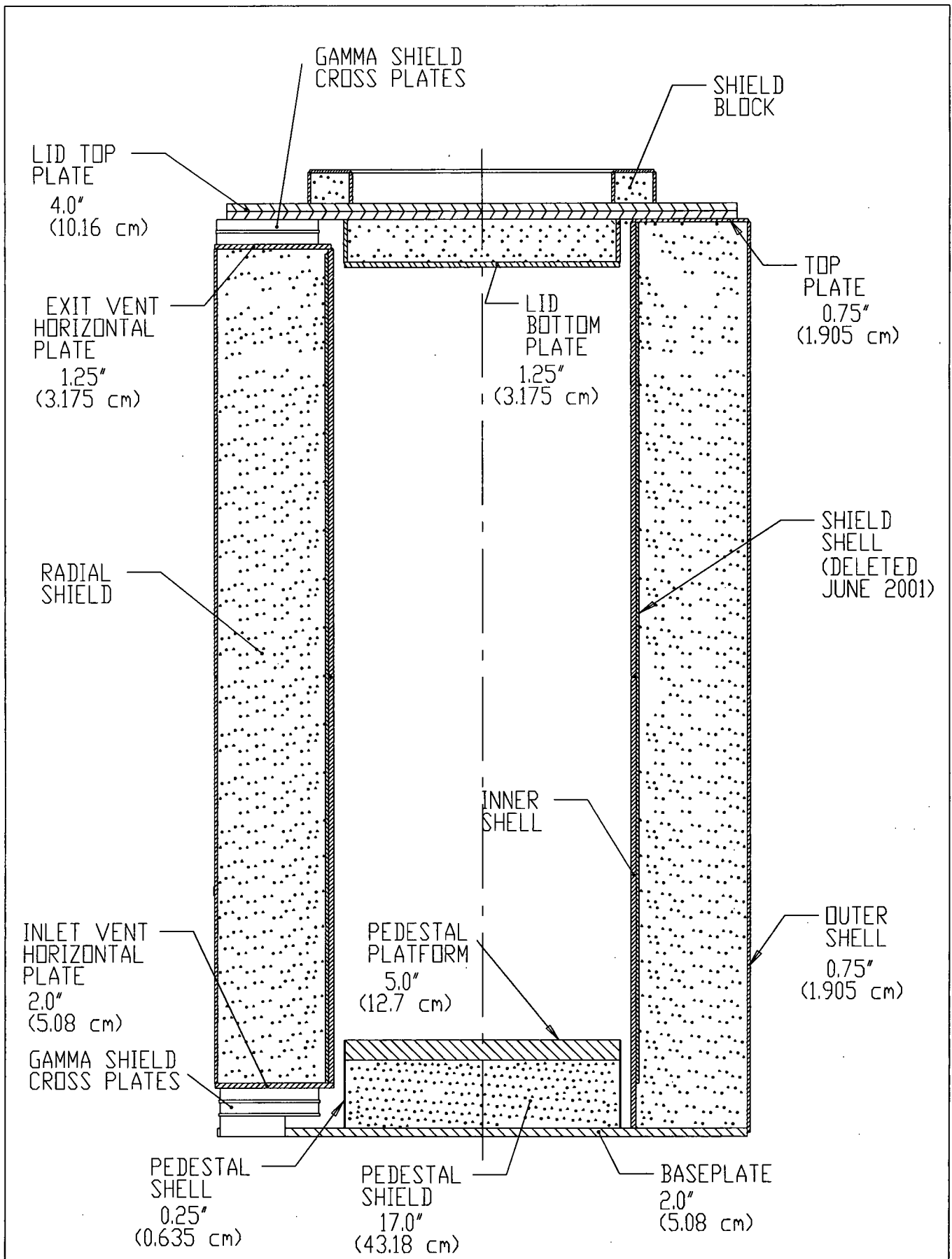


FIGURE 5.3.11; HI-STORM 100 OVERPACK CROSS SECTIONAL ELEVATION VIEW

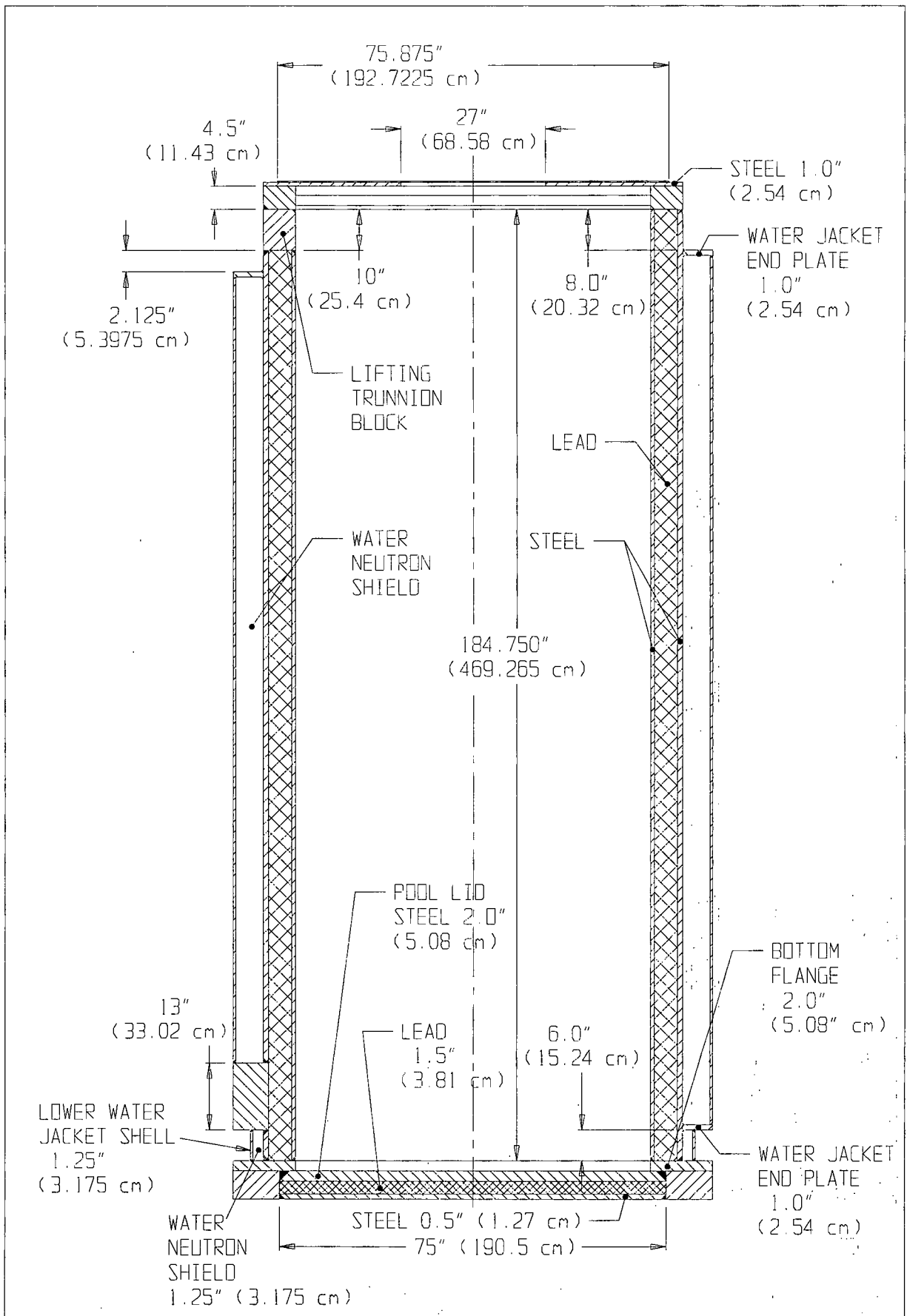


FIGURE 5.3.12; 100-TON HI-TRAC TRANSFER CASK WITH POOL LID CROSS SECTIONAL ELEVATION VIEW (AS MODELED)

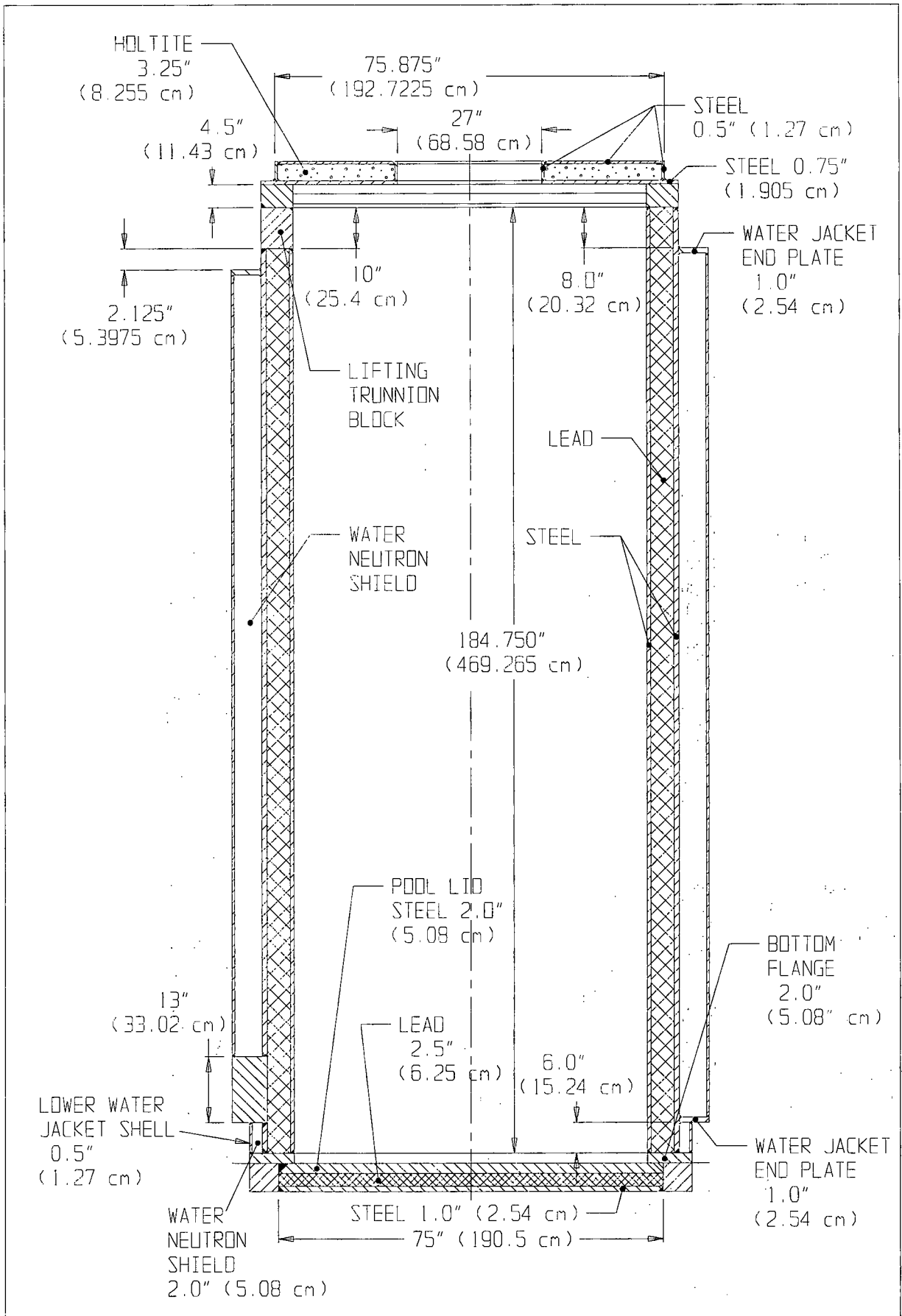
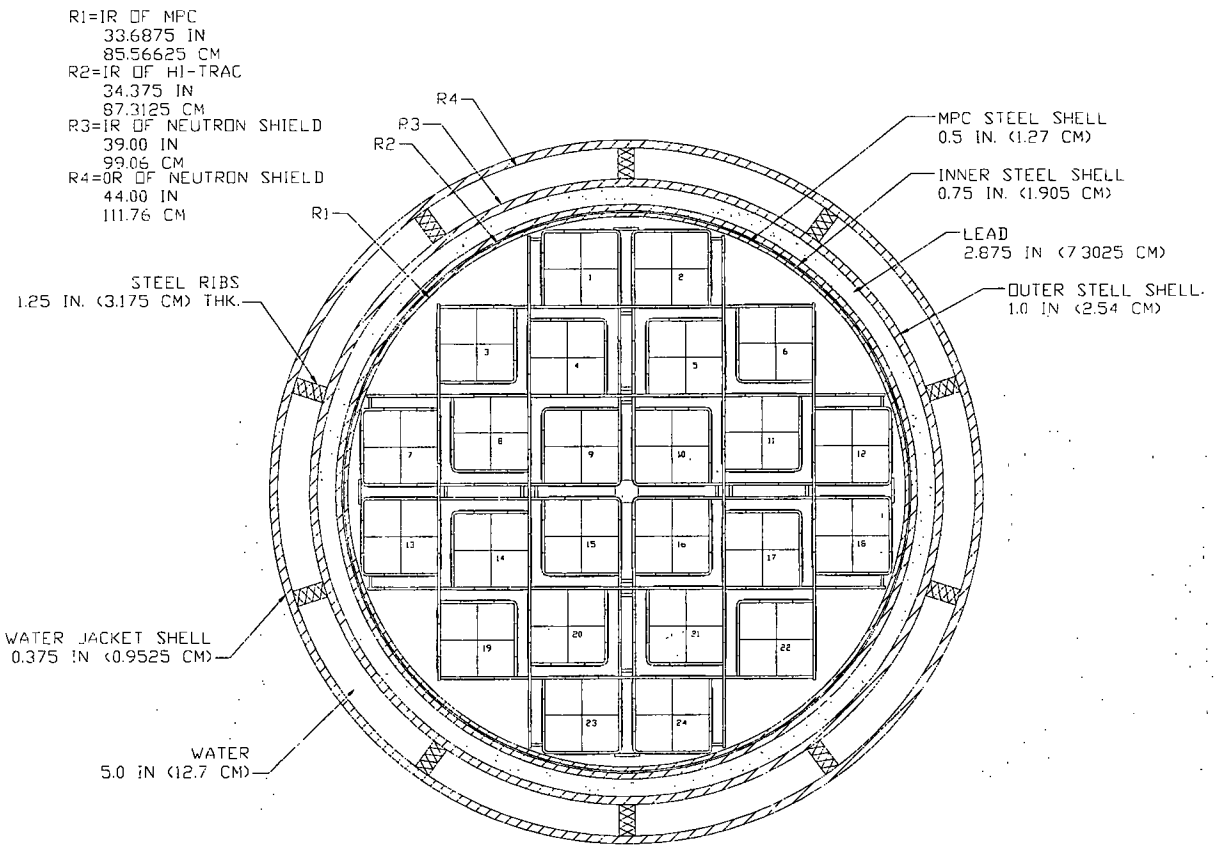


FIGURE 5.3.13; 125-TON HI-TRAC TRANSFER CASK WITH POOL LID CROSS SECTIONAL ELEVATION VIEW (AS MODELED)



Note: The HI-TRAC 100 has 10 steel ribs as shown. The HI-TRAC 100D has 8 steel ribs evenly spaced with thickness as shown.

FIGURE 5.3.14; HI-TRAC 100 AND 100D TRANSFER CASK CROSS SECTIONAL VIEW (AS MODELED)

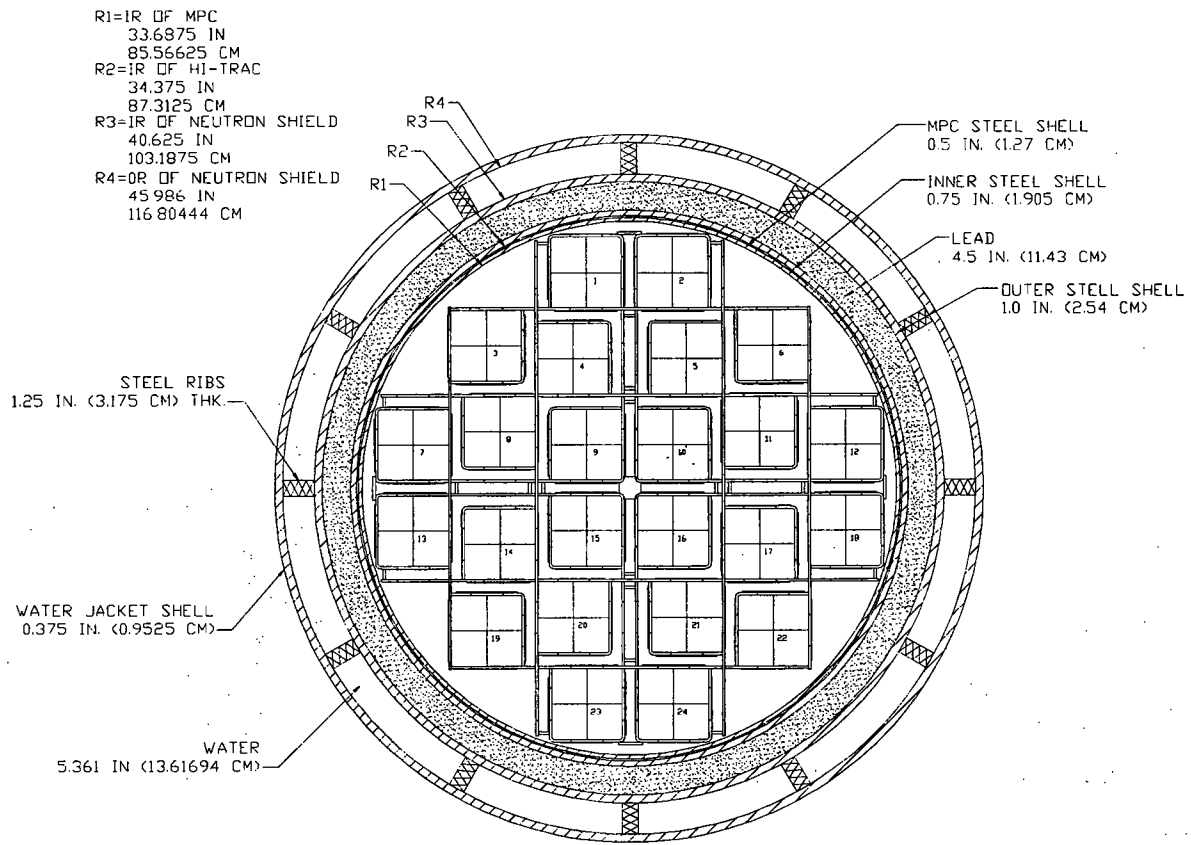
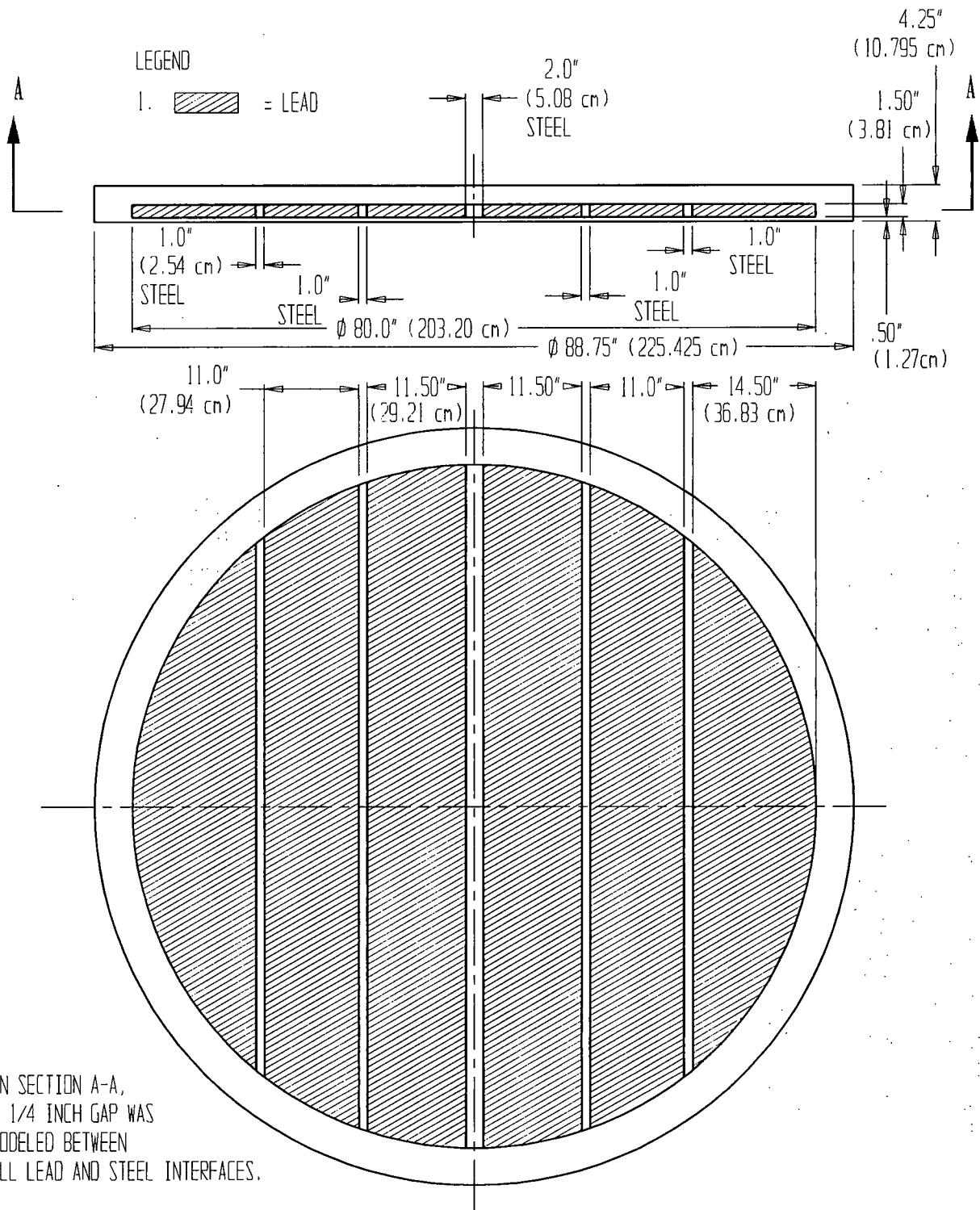


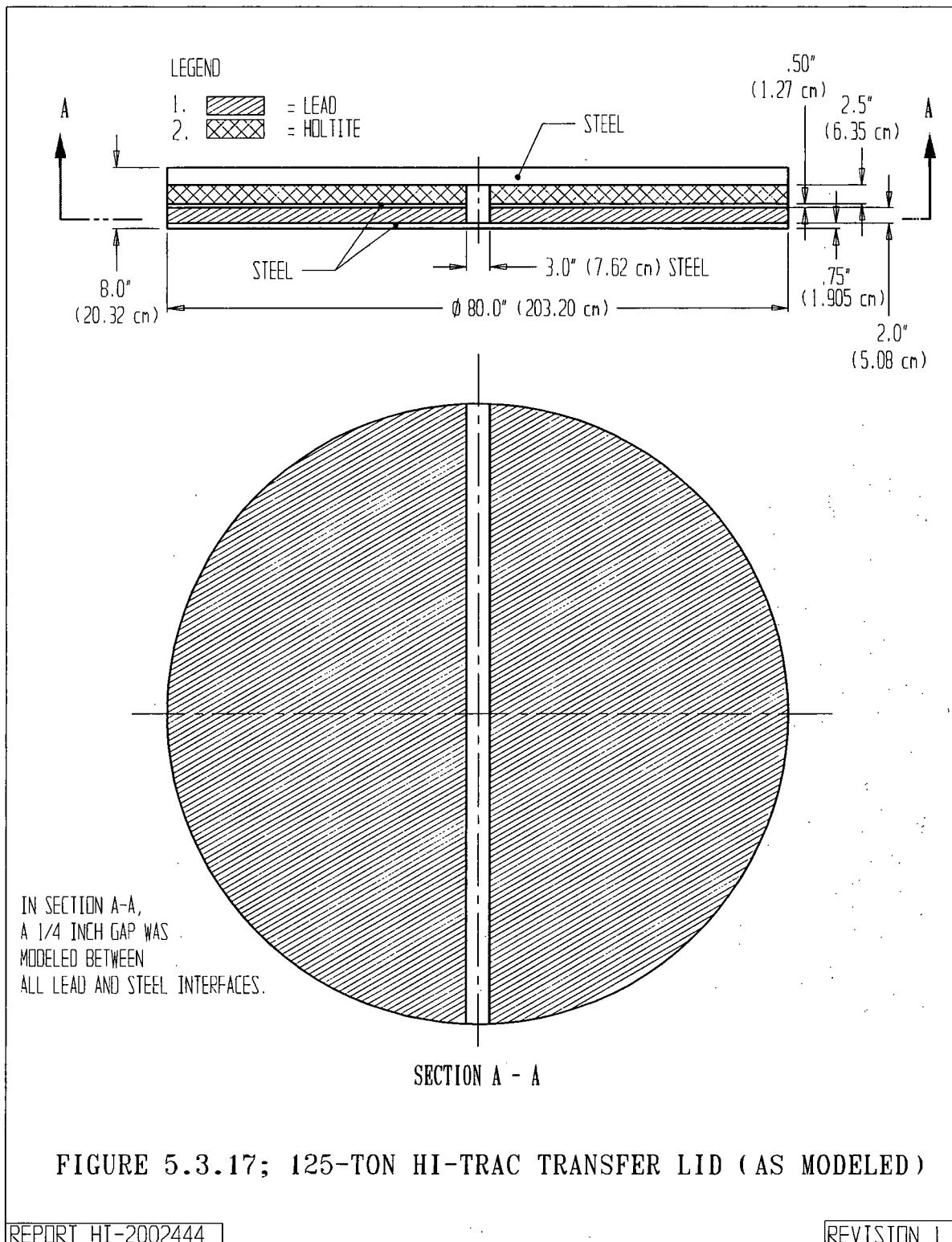
FIGURE 5.3.15; HI-TRAC 125 TRANSFER CASK CROSS SECTIONAL VIEW (AS MODELED)



IN SECTION A-A,
 A 1/4 INCH GAP WAS
 MODELED BETWEEN
 ALL LEAD AND STEEL INTERFACES.

SECTION A - A

FIGURE 5.3.16; 100-TON HI-TRAC TRANSFER LID (AS MODELED)



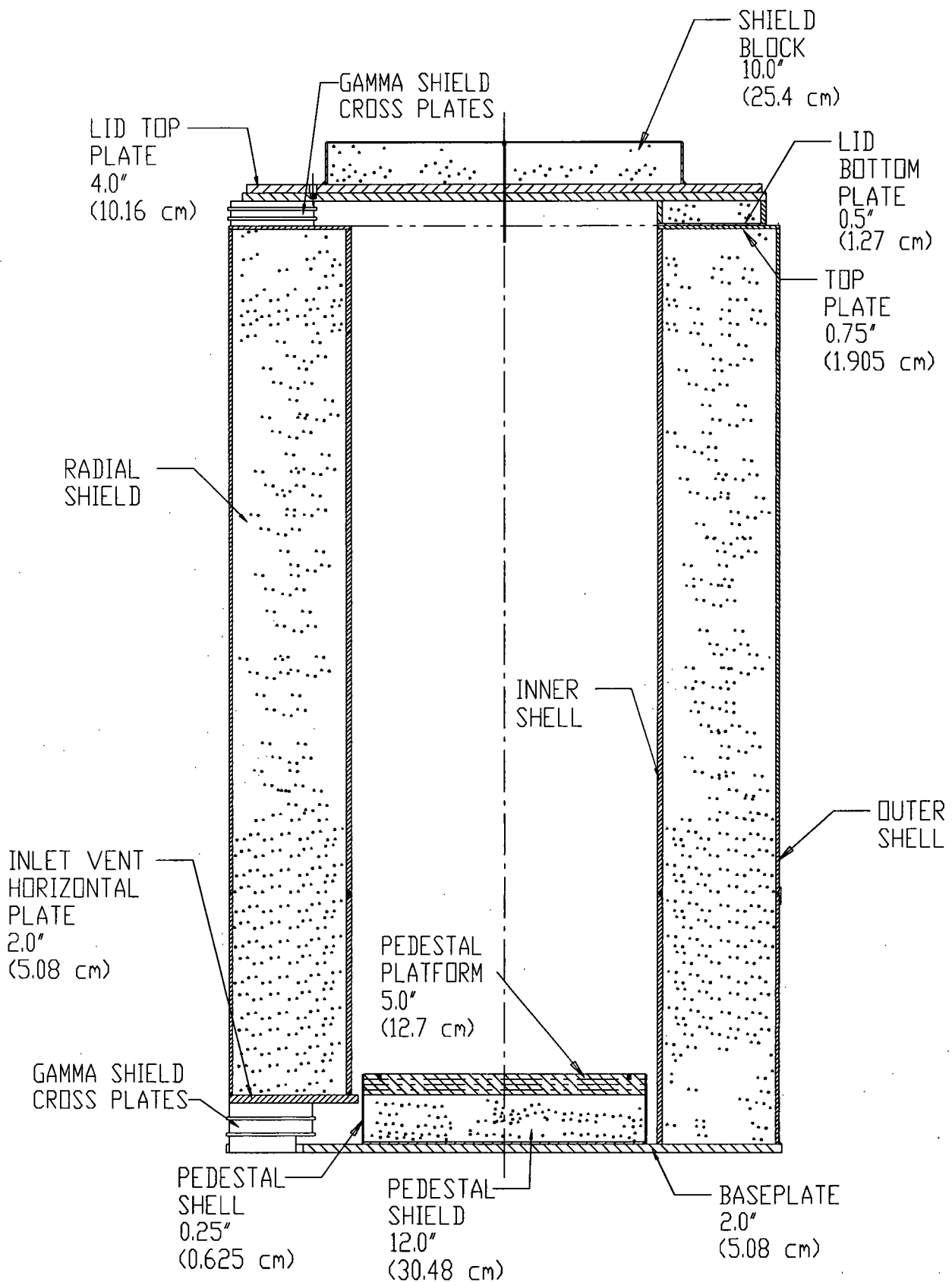
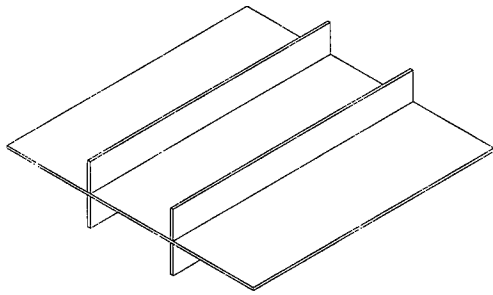
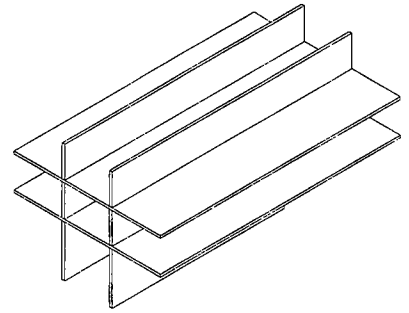


FIGURE 5.3.18; HI-STORM 100S OVERPACK CROSS SECTIONAL ELEVATION VIEW

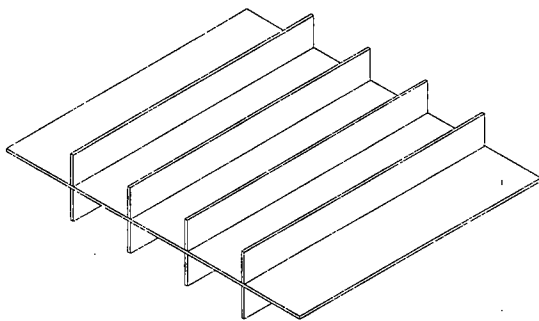


OUTLET VENT

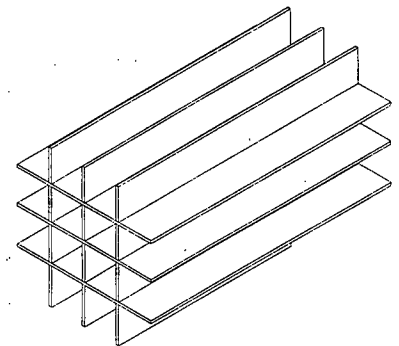


INLET VENT

MANDATORY GAMMA SHIELD CROSS PLATES FOR HI-STORM 100 AND HI-STORM 100S

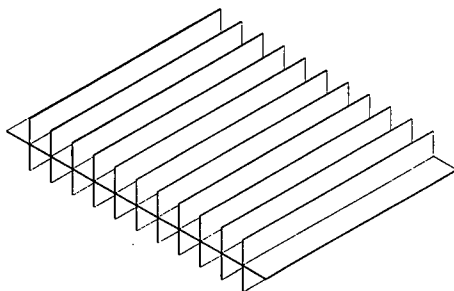


OUTLET VENT

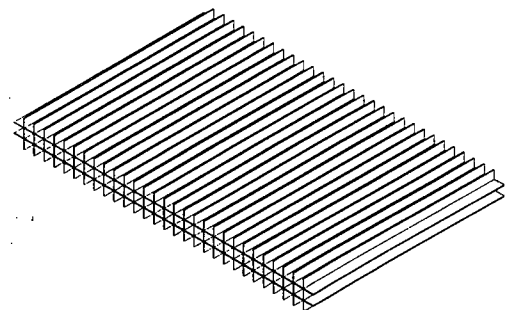


INLET VENT

OPTIONAL GAMMA SHIELD CROSS PLATES FOR HI-STORM 100S THAT MAY BE USED INSTEAD OF THE MANDATORY DEVICES.



OUTLET VENT



INLET VENT

MANDATORY GAMMA SHIELD CROSS PLATES FOR HI-STORM 100S VERSION B

FIGURE 5.3.19: GAMMA SHIELD CROSS PLATE CONFIGURATION OF HI-STORM 100, HI-STORM 100S, AND HI-STORM 100S VERSION B

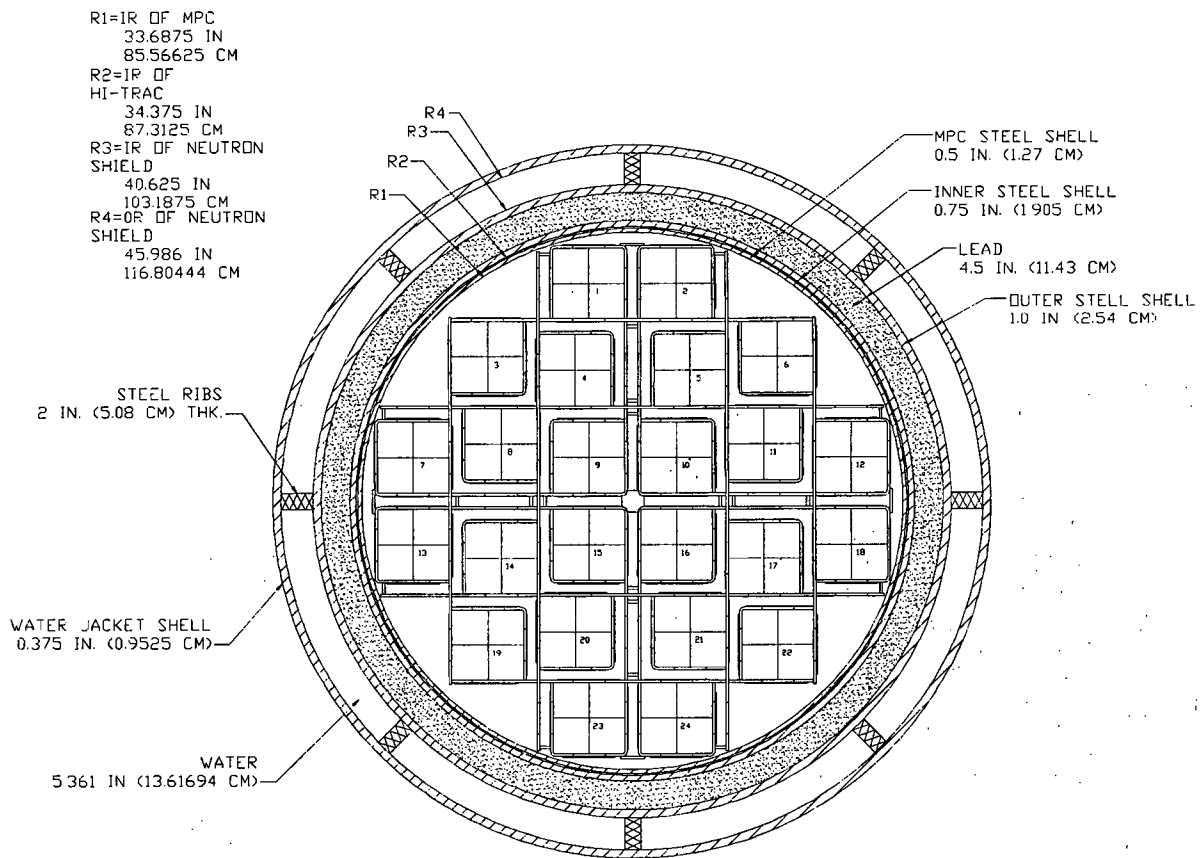


FIGURE 5.3.20; HI-TRAC 125D TRANSFER CASK CROSS SECTIONAL VIEW (AS MODELED)

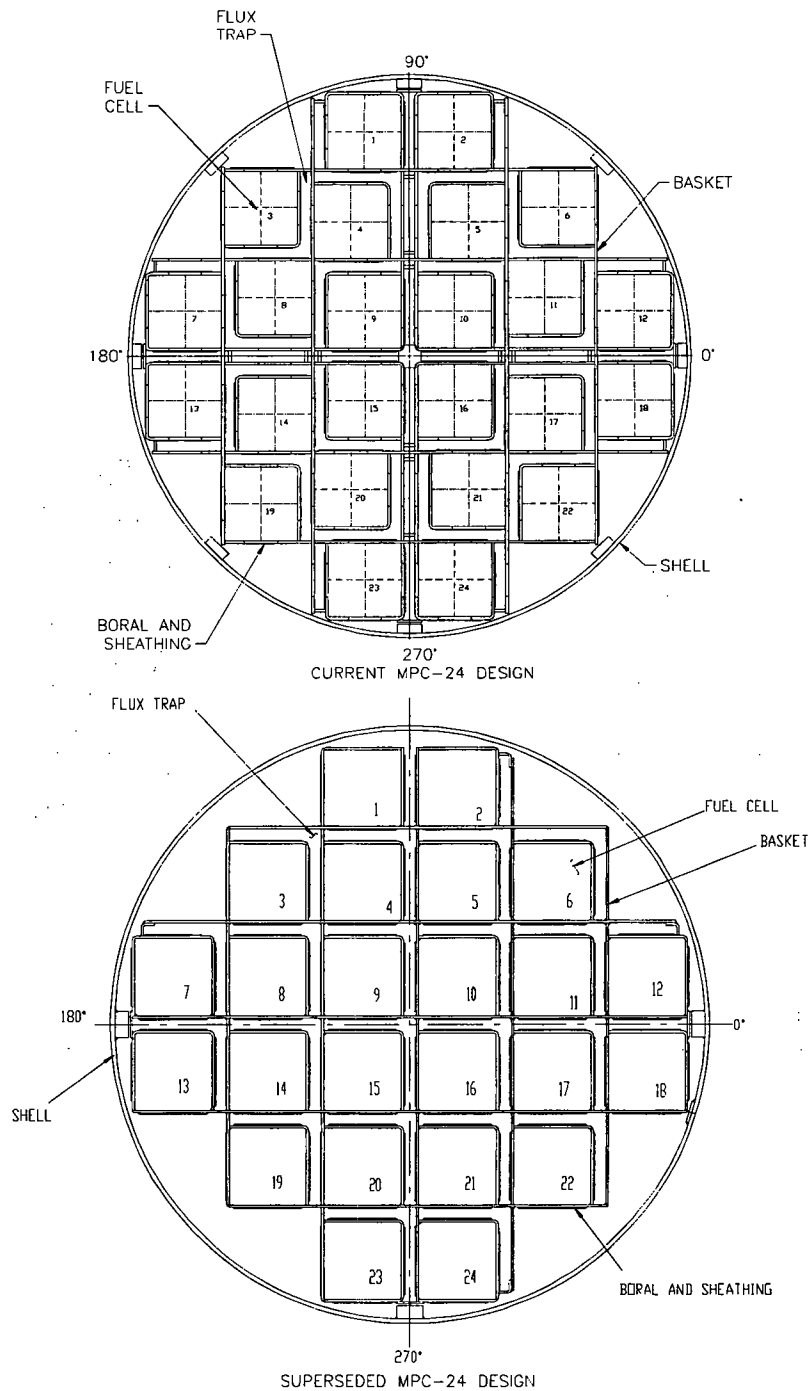


FIGURE 5.3.21; CROSS SECTIONAL VIEWS OF THE CURRENT MPC-24 DESIGN AND THE SUPERSEDED MPC-24 WHICH IS USED IN THE MCNP MODELS.

REPORT HI-2002444

REV. 1

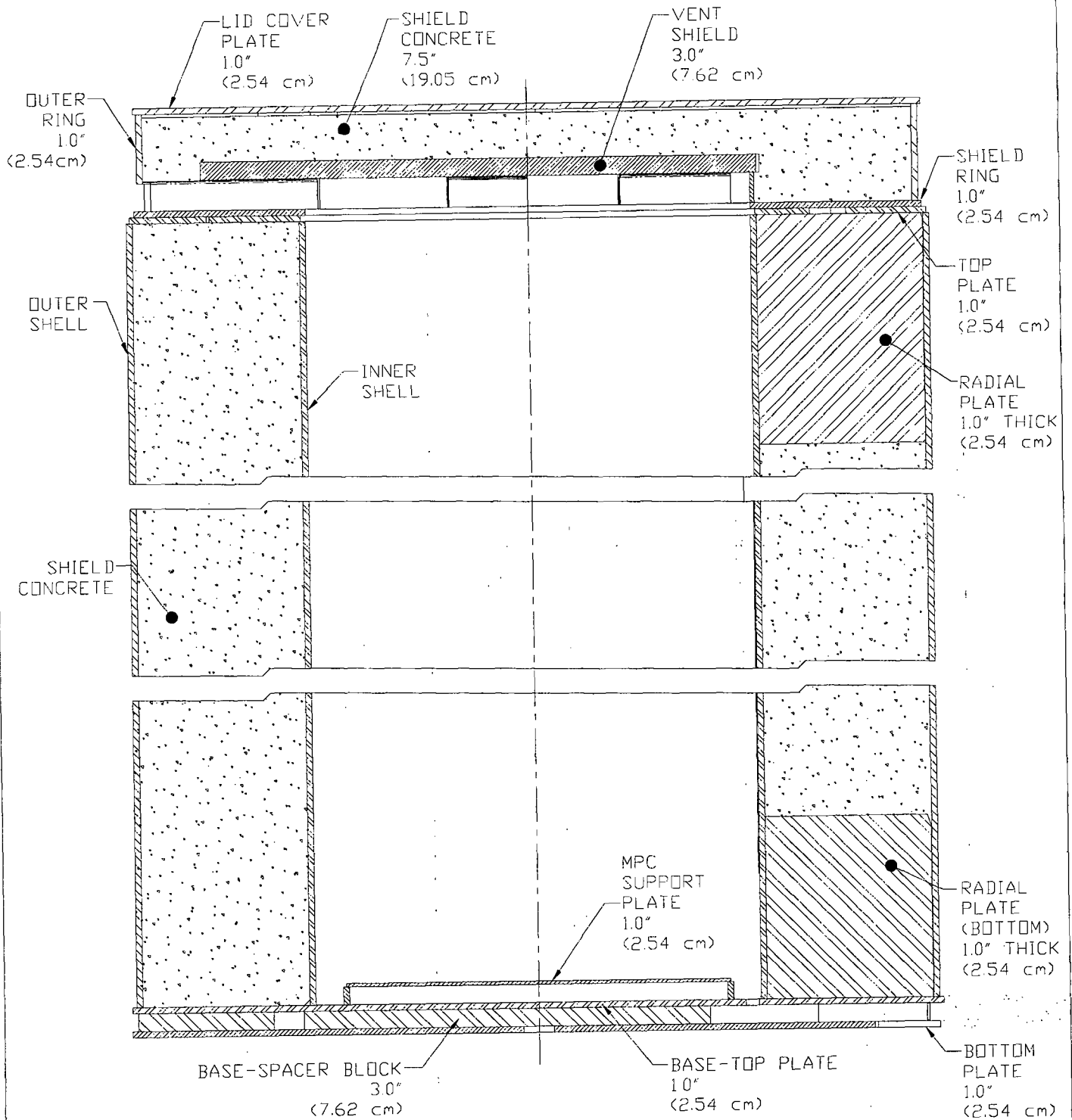


FIGURE 5.3.22; HI-STORM 100S VERSION B OVERPACK CROSS SECTIONAL ELEVATION VIEW

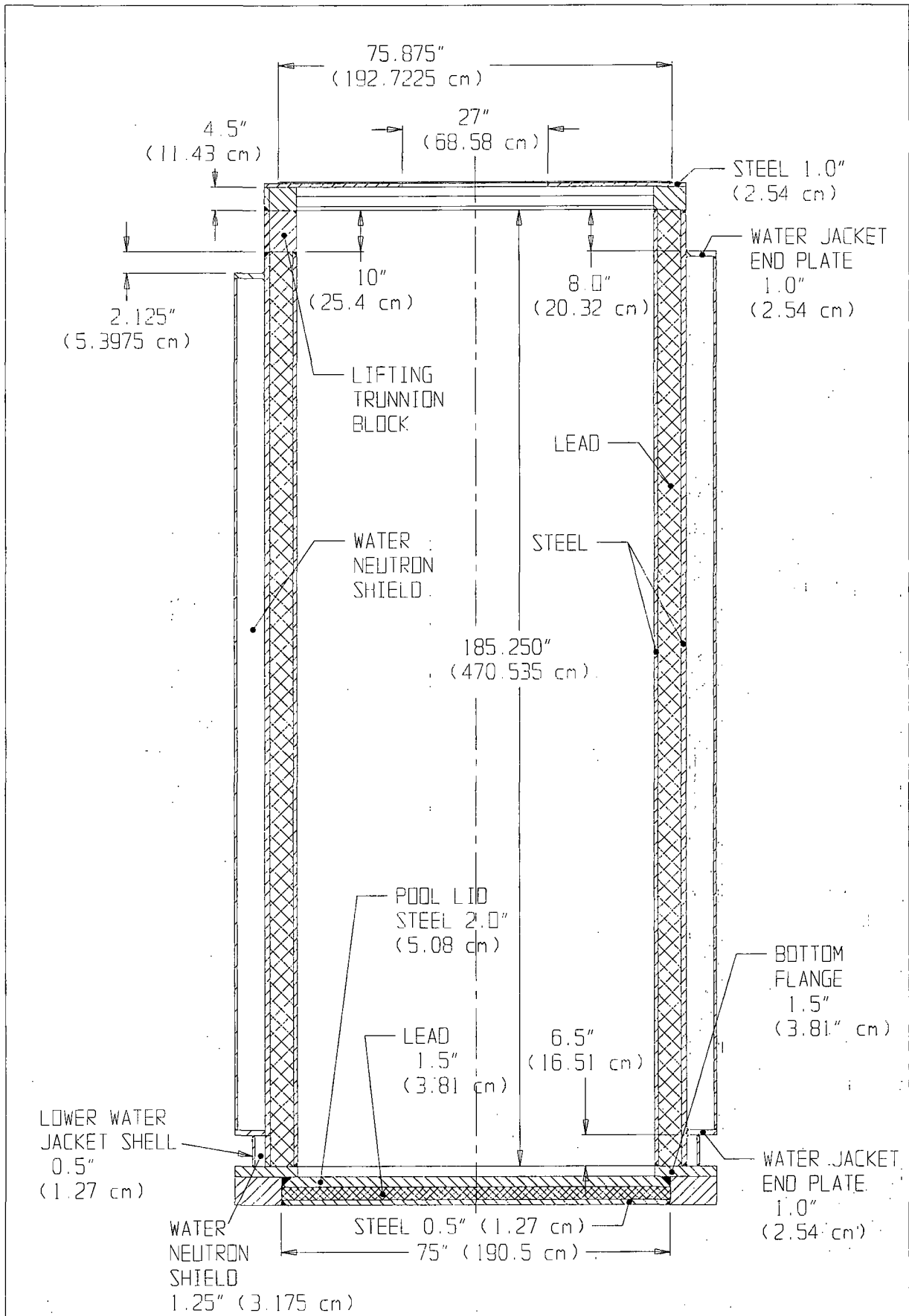


FIGURE 5.3.23; HI-TRAC 100D TRANSFER CASK WITH POOL LID CROSS SECTIONAL ELEVATION VIEW (AS MODELED)

5.4 SHIELDING EVALUATION

The MCNP-4A code was used for all of the shielding analyses [5.1.1]. MCNP is a continuous energy, three-dimensional, coupled neutron-photon-electron Monte Carlo transport code. Continuous energy cross section data are represented with sufficient energy points to permit linear-linear interpolation between points. The individual cross section libraries used for each nuclide are those recommended by the MCNP manual. All of these data are based on ENDF/B-V data. MCNP has been extensively benchmarked against experimental data by the large user community. References [5.4.2], [5.4.3], and [5.4.4] are three examples of the benchmarking that has been performed.

The energy distribution of the source term, as described earlier, is used explicitly in the MCNP model. A different MCNP calculation is performed for each of the three source terms (neutron, decay gamma, and ^{60}Co). The axial distribution of the fuel source term is described in Table 2.1.11 and Figures 2.1.3 and 2.1.4. The PWR and BWR axial burnup distributions were obtained from References [5.4.5] and [5.4.6], respectively. These axial distributions were obtained from operating plants and are representative of PWR and BWR fuel with burnups greater than 30,000 MWD/MTU. The ^{60}Co source in the hardware was assumed to be uniformly distributed over the appropriate regions.

It has been shown that the neutron source strength varies as the burnup level raised by the power of 4.2. Since this relationship is non-linear and since the burnup in the axial center of a fuel assembly is greater than the average burnup, the neutron source strength in the axial center of the assembly is greater than the relative burnup times the average neutron source strength. In order to account for this effect, the neutron source strength in each of the 10 axial nodes listed in Table 2.1.11 was determined by multiplying the average source strength by the relative burnup level raised to the power of 4.2. The peak relative burnups listed in Table 2.1.11 for the PWR and BWR fuels are 1.105 and 1.195 respectively. Using the power of 4.2 relationship results in a 37.6% ($1.105^{4.2}/1.105$) and 76.8% ($1.195^{4.2}/1.195$) increase in the neutron source strength in the peak nodes for the PWR and BWR fuel, respectively. The total neutron source strength increases by 15.6% for the PWR fuel assemblies and 36.9% for the BWR fuel assemblies.

MCNP was used to calculate doses at the various desired locations. MCNP calculates neutron or photon flux and these values can be converted into dose by the use of dose response functions. This is done internally in MCNP and the dose response functions are listed in the input file in Appendix 5.C. The response functions used in these calculations are listed in Table 5.4.1 and were taken from ANSI/ANS 6.1.1, 1977 [5.4.1].

The dose rates at the various locations were calculated with MCNP using a two step process. The first step was to calculate the dose rate for each dose location per starting particle for each neutron and gamma group in the fuel and each axial location in the end fittings. The second and last step was to multiply the dose rate per starting particle for each group or starting location by the source strength (i.e. particles/sec) in that group or location and sum the resulting dose rates

for all groups in each dose location. The standard deviations of the various results were statistically combined to determine the standard deviation of the total dose in each dose location.

The HI-STORM shielding analysis was performed for conservative burnup and cooling time combinations which bound the uniform and regionalized loading specifications for zircaloy clad fuel specified in Section 2.1.9. Therefore, the HI-STORM shielding analysis presented in this chapter is conservatively bounding for the MPC-24, MPC-32, and MPC-68.

Tables 5.1.11 through 5.1.13 provide the maximum dose rates adjacent to the HI-STORM overpack during normal conditions for each of the MPCs. Tables 5.1.14 through 5.1.16 provide the maximum dose rates at one meter from the overpack. A detailed discussion of the normal, off-normal, and accident condition dose rates is provided in Sections 5.1.1 and 5.1.2.

Tables 5.1.7 and 5.1.8 provide dose rates for the 100-ton and 125-ton HI-TRAC transfer casks, respectively, with the MPC-24 loaded with design basis fuel in the normal condition, in which the MPC is dry and the HI-TRAC water jacket is filled with water. Table 5.4.2 shows the corresponding dose rates adjacent to and one meter away from the 100-ton HI-TRAC for the fully flooded MPC condition with an empty water-jacket (condition in which the HI-TRAC is removed from the spent fuel pool). Table 5.4.3 shows the dose rates adjacent to and one meter away from the 100-ton HI-TRAC for the fully flooded MPC condition with the water jacket filled with water (condition in which welding operations are performed). Dose locations 4 and 5, which are on the top and bottom of the HI-TRAC were not calculated at the one-meter distance for these configurations. For the conditions involving a fully flooded MPC, the internal water level was 10 inches below the MPC lid. These dose rates represent the various conditions of the HI-TRAC during operations. Comparing these results to Table 5.1.7 indicates that the dose rates in the upper and lower portions of the HI-TRAC are reduced by about 50% with the water in the MPC. The dose at the center of the HI-TRAC is reduced by approximately 50% when there is also water in the water jacket and is essentially unchanged when there is no water in the water jacket as compared to the normal condition results shown in Table 5.1.7.

The burnup and cooling time combination of 60,000 MWD/MTU and 3 years was selected for the 100-ton MPC-24 HI-TRAC analysis because this combination of burnup and cooling time results in the highest dose rates, and therefore, bounds all other requested combinations in the 100-ton HI-TRAC. The dose rate at 1 meter from the pool lid was not calculated because a concrete floor was placed 6 inches below the pool lid to account for potential ground scattering. These results in Table 5.1.7 clearly indicate that gammas are the dominant portion of the total dose rate. Therefore, as the burnup and cooling time increase, the reduction in the gamma dose rate due to the increased cooling time results in a net decrease in the total dose rate.

In contrast, the dose rates surrounding the HI-TRAC 125 and 125D transfer casks have significantly higher neutron component. Therefore, the dose rates at 75,000 MWD/MTU burnup and 5 year cooling are higher than the dose rates at 60,000 MWD/MTU burnup and 3 year

cooling. The dose rates for the 125-ton HI-TRACs with the MPC-24 at 75,000 MWD/MTU and 5 year cooling are listed in Table 5.1.8 of Section 5.1.

Table 5.4.9 provides dose rates adjacent to and one meter away from the 100-ton HI-TRAC with the MPC-68 at a burnup and cooling time combination of 50,000 MWD/MTU and 3 years. The dose rate at 1 meter from the pool lid was not calculated because a concrete floor was placed 6 inches below the pool lid to account for potential ground scattering. These results demonstrate that the dose rates on contact at the top and bottom of the 100-ton HI-TRAC are somewhat higher in the MPC-68 case than in the MPC-24 case. However, the MPC-24 produces higher dose rates than the MPC-68 at the center of the HI-TRAC, on-contact, and at locations 1 meter away from the HI-TRAC. Therefore, the MPC-24 is still used for the exposure calculations in Chapter 10 of the FSAR.

Table 5.4.11 provides dose rates adjacent to and one meter away from the 100-ton HI-TRAC with the MPC-32 at burnup and cooling time combination of 45,000 MWD/MTU and 3 years. The dose rate at 1 meter from the pool lid was not calculated because a concrete floor was placed 6 inches below the pool lid to account for potential ground scattering. These results demonstrate that the dose rates on contact at the top of the 100-ton HI-TRAC are somewhat higher in the MPC-32 case than in the MPC-24 case. However, the MPC-24 produces higher dose rates than the MPC-32 at the center of the HI-TRAC, on-contact, and at locations 1 meter away from the HI-TRAC. Therefore, the MPC-24 is still used for the exposure calculations in Chapter 10 of the FSAR.

Table 5.4.19 provides dose rates adjacent to and one meter away from the radial surface of the HI-TRAC 100D with the MPC-32 at a burnup of 35,000 MWD/MTU and a cooling time of 3 years. Results are presented only for dose locations 1 through 3 since the differences between the HI-TRAC 100 and the 100D will only affect the dose rates on the side of the transfer cask. A comparison of these results to those provided in Table 5.4.11 indicates that the dose rates at 1 meter from the transfer cask are very similar to the dose rates for the 100-ton HI-TRAC.

As mentioned in Section 5.0, all MPCs offer a regionalized loading pattern as described in Section 2.1.9. This loading pattern authorizes fuel of higher decay heat than uniform loading (i.e. higher burnups and shorter cooling times) to be stored in either the center region, region 1, of the MPC or the outer region, region 2. From a shielding perspective, placing the older fuel on the outside provides shielding for the inner fuel in the radial direction. Note that for the MPC-24 there are some inner region assemblies that have a corner area with a direct line of sight to the MPC shell and therefore the outer region will not provide quite as much additional shielding over the whole surface area of the cask as it does for the MPC-32 and MPC-68. Based on analysis for the MPC-32 and MPC-68 using the same burnup and cooling times in region 1 and 2 the following percentages were calculated for dose location 2 on the 100-ton HI-TRAC.

- Approximately 21% and 27% of the neutron dose at the edge of the water jacket comes from region 1 fuel assemblies in the MPC-32 and MPC-68, respectively.

Region 1 contains 12 (38% of total) and 32 (47% of total) assemblies in the MPC-32 and MPC-68, respectively. For the MPC-24, where region 1 contains 12 (50% of total) assemblies, the contribution would be similar.

- Approximately 1% and 2% of the photon dose at the edge of the water jacket comes from region 1 fuel assemblies in the MPC-32 and MPC-68, respectively. For the MPC-24, where some corners of the region 1 assemblies are not completely shielded by the outer assemblies, the contribution of the photon dose from region 1 would be slightly larger than for the MPC-32 and MPC-68, but the gamma dose rates would still be dominated by the outer assemblies.

These results clearly indicate that the outer fuel assemblies shield almost the entire gamma source from the inner assemblies in the radial direction and a significant percentage of the neutron source. The conclusion from this analysis is that the total dose rate on the external radial surfaces of the cask can be greatly reduced by placing longer cooled and lower burnup fuels on the outside of the basket. Note that for the MPC-24 there may be localized higher dose rates using regionalized loading, since the inner region is not totally surrounded by the outer region. However, the dose rates would always be bounded by the values presented in this chapter. In the axial direction, regionalized loading with higher burnup fuel on the inside results in higher dose rates in the center portion of the cask since the region 2 assemblies are not shielding the region 1 assemblies for axial dose locations.

Note that the regionalized loading scheme also allows placing higher burned or shorter cooled assemblies on the periphery of the basket. In this case, dose rate would be closer to the bounding values presented here. This configuration should only be used if it is not feasible to place such assemblies in the center of the cask.

Burnup and cooling time combinations which bound both regionalized loading and uniform loading patterns were analyzed. Therefore, dose rates for specific regionalized loading patterns are not presented in this chapter. Section 5.4.9 provides a brief additional discussion on regionalized loading dose rates.

Unless otherwise stated all tables containing dose rates for design basis fuel refer to design basis intact zircaloy clad fuel.

Since MCNP is a statistical code, there is an uncertainty associated with the calculated values. In MCNP the uncertainty is expressed as the relative error which is defined as the standard deviation of the mean divided by the mean. Therefore, the standard deviation is represented as a percentage of the mean. The relative error for the total dose rates presented in this chapter were typically less than 5% and the relative error for the individual dose components was typically less than 10%.

5.4.1 Streaming Through Radial Steel Fins and Pocket Trunnions and Azimuthal Variations

The HI-STORM 100 overpack and the HI-TRAC utilize radial steel fins for structural support and cooling. The attenuation of neutrons through steel is substantially less than the attenuation of neutrons through concrete and water. Therefore, it is possible to have neutron streaming through the fins that could result in a localized dose peak. The reverse is true for photons, which would result in a localized reduction in the photon dose. In addition to the fins, the pocket trunnions in the HI-TRAC 100 and 125 are essentially blocks of steel that are approximately 12 inches wide and 12 inches high. The effect of the pocket trunnion on neutron streaming and photon transmission will be more substantial than the effect of a single fin.

Analysis of the pocket trunnions in the HI-TRAC 100 and 125 and the steel fins in the HI-TRAC 100, 125, and 125D indicate that neutron streaming is noticeable at the surface of the transfer cask. The neutron dose rate on the surface of the pocket trunnion is approximately 5 times higher than the circumferential average dose rate at that location. The gamma dose rate is approximately 10 times lower than the circumferential average dose rate at that location. The streaming at the rib location is the largest in the HI-TRAC 125D because the ribs are thicker than in the HI-TRAC 100 or 125. The neutron dose rate on the surface of the rib in the 125D is approximately 3 times higher than the circumferential average dose rate at that location. The gamma dose rate on the surface of the rib in the 125D is approximately 3 times lower than the circumferential average dose rate at that location. At one meter from the cask surface there is little difference between the dose rates calculated over the fins and the pocket trunnions compared to the other areas of the water jackets.

These conclusions indicate that localized neutron streaming is noticeable on the surface of the transfer casks. However, at one meter from the surface the streaming has dissipated. Since most HI-TRAC operations will involve personnel moving around the transfer cask at some distance from the cask only surface average dose rates are reported in this chapter.

Below each lifting trunnion, there is a localized area where the water jacket has been reduced in height by 4.125 inches to accommodate the lift yoke (see Figures 5.3.12 and 5.3.13). This area experiences a significantly higher than average dose rate on contact of the HI-TRAC. The peak dose in this location is 2.9 Rem/hr for the MPC-32, 2.0 Rem/hr for the MPC-68 and 2.4 Rem/hr for the MPC-24 in the 100-ton HI-TRAC and 1.7 Rem/hr for the MPC-24 in the HI-TRAC 125D. At a distance of 1 to 2 feet from the edge of the HI-TRAC the localized effect is greatly reduced. This dose rate is acceptable because during lifting operations the lift yoke will be in place, which, due to the additional lift yoke steel (~3 inches), will greatly reduce the dose rate. However, more importantly, people will be prohibited from being in the vicinity of the lifting trunnions during lifting operations as a standard rigging practice. In addition the lift yoke is remote in its attachment and detachment, further minimizing personnel exposure. Immediately following the detachment of the lift yoke, in preparation for closure operations, temporary shielding may be placed in this area. Any temporary shielding (e.g., lead bricks, water tanks, lead blankets, steel plates, etc.) is sufficient to attenuate the localized hot spot. The operating procedure in Chapter 8

discusses the placement of temporary shielding in this area. For the 100-ton HI-TRAC, the optional temporary shield ring will replace the water that was lost from the axial reduction in the water jacket thereby eliminating the localized hot spot. When the HI-TRAC is in the horizontal position, during transport operations, it will (at a minimum) be positioned a few feet off the ground by the transport vehicle and therefore this location below the lifting trunnions will be positioned above people which will minimize the effect on personnel exposure. In addition, good operating practice will dictate that personnel remain at least a few feet away from the transport vehicle. During vertical transport of a loaded HI-TRAC, the localized hot spot will be even further from the operating personnel. Based on these considerations, the conclusion is that this localized hot spot does not significantly impact the personnel exposure.

5.4.2 Damaged Fuel Post-Accident Shielding Evaluation

5.4.2.1 Dresden 1 and Humboldt Bay Damaged Fuel

As discussed in Section 5.2.5.2, the analysis presented below, even though it is for damaged fuel, demonstrates the acceptability of storing intact Humboldt Bay 6x6 and intact Dresden 1 6x6 fuel assemblies.

For the damaged fuel and fuel debris accident condition, it is conservatively assumed that the damaged fuel cladding ruptures and all the fuel pellets fall and collect at the bottom of the damaged fuel container. The inner dimension of the damaged fuel container, specified in the Design Drawings of Chapter 1, and the design basis damaged fuel and fuel debris assembly dimensions in Table 5.2.2 are used to calculate the axial height of the rubble in the damaged fuel container assuming 50% compaction. Neglecting the fuel pellet to cladding inner diameter gap, the volume of cladding and fuel pellets available for deposit is calculated assuming the fuel rods are solid. Using the volume in conjunction with the damaged fuel container, the axial height of rubble is calculated to be 80 inches.

Dividing the total fuel gamma source for a 6x6 fuel assembly in Table 5.2.7 by the 80 inch rubble height provides a gamma source per inch of $3.41\text{E}+12$ photon/s. Dividing the total neutron source for a 6x6 fuel assembly in Table 5.2.18 by 80 inches provides a neutron source per inch of $2.75\text{E}+05$ neutron/s. These values are both bounded by the BWR design basis fuel gamma source per inch and neutron source per inch values of $1.08\text{E}+13$ photon/s and $9.17\text{E}+05$ neutron/s, respectively, for a burnup and cooling time of 40,000 MWD/MTU and 5 years. These BWR design basis values were calculated by dividing the total source strengths for 40,000 MWD/MTU and 5 year cooling by the active fuel length of 144 inches. Therefore, damaged Dresden 1 and Humboldt Bay fuel assemblies are bounded by the design basis intact BWR fuel assembly for accident conditions. No explicit analysis of the damaged fuel dose rates from Dresden 1 or Humboldt Bay fuel assemblies are provided as they are bounded by the intact fuel analysis.

5.4.2.2 Generic PWR and BWR Damaged Fuel

HOLTEC INTERNATIONAL COPYRIGHTED MATERIAL

HI-STORM FSAR
REPORT HI-2002444

5.4-6

Rev. 11

The Holtec Generic PWR and BWR DFCs are designed to accommodate any PWR or BWR fuel assembly that can physically fit inside the DFC. Damaged fuel assemblies under normal conditions, for the most part, resemble intact fuel assemblies from a shielding perspective. Under accident conditions, it can not be guaranteed that the damaged fuel assembly will remain intact. As a result, the damaged fuel assembly may begin to resemble fuel debris in its possible configuration after an accident.

Since damaged fuel is identical to intact fuel from a shielding perspective no specific analysis is required for damaged fuel under normal conditions. However, a generic shielding evaluation was performed to demonstrate that fuel debris under normal or accident conditions, or damaged fuel in a post-accident configuration, will not result in a significant increase in the dose rates around the 100-ton HI-TRAC. Only the 100-ton HI-TRAC was analyzed because it can be concluded that if the dose rate change is not significant for the 100-ton HI-TRAC then the change will not be significant for the 125-ton HI-TRACs or the HI-STORM overpacks.

Fuel debris or a damaged fuel assembly which has collapsed can have an average fuel density which is higher than the fuel density for an intact fuel assembly. If the damaged fuel assembly was to fully or partially collapse, the fuel density in one portion of the assembly would increase and the density in the other portion of the assembly would decrease. This scenario was analyzed with MCNP-4A in a conservative bounding fashion to determine the potential change in dose rate as a result of fuel debris or a damaged fuel assembly collapse. The analysis consisted of modeling the fuel assemblies in the damaged fuel locations in the MPC-24 (4 peripheral locations in the MPC-24E or MPC-24EF) and the MPC-68 (16 peripheral locations) with a fuel density that was twice the normal fuel density and correspondingly increasing the source rate for these locations by a factor of two. A flat axial power distribution was used which is approximately representative of the source distribution if the top half of an assembly collapsed into the bottom half of the assembly. Increasing the fuel density over the entire fuel length, rather than in the top half or bottom half of the fuel assembly, is conservative and provides the dose rate change in both the top and bottom portion of the cask.

Tables 5.4.13 and 5.4.14 provide the results for the MPC-24 and MPC-68, respectively. Only the radial dose rates are provided since the axial dose rates will not be significantly affected because the damaged fuel assemblies are located on the periphery of the baskets. A comparison of these results to the results in Tables 5.1.7 and 5.4.9 indicate that the dose rates in the top and bottom portion of the 100-ton HI-TRAC increase by less than 27% while the dose rate in the center of the HI-TRAC actually decreases a little bit. The increase in the bottom and top is due to the assumed flat power distribution. The dose rates shown in Tables 5.4.13 and 5.4.14 were averaged over the circumference of the cask. Since almost all of the peripheral cells in the MPC-68 are filled with DFCs, an azimuthal variation would not be expected for the MPC-68. However, since there are only 4 DFCs in the MPC-24E, an azimuthal variation in dose due to the damaged fuel/fuel debris might be expected. Therefore, the dose rates were evaluated in four smaller regions, one outside each DFC, that encompass about 44% of the circumference. There was no significant change in the dose rate as a result of the localized dose calculation. These results

indicate that the potential effect on the dose rate is not very significant for the storage of damaged fuel and/or fuel debris. This conclusion is further reinforced by the fact that the majority of the significantly damaged fuel assemblies in the spent fuel inventories are older assemblies from the earlier days of nuclear plant operations. Therefore, these assemblies will have a considerably lower burnup and longer cooling times than the assemblies analyzed in this chapter.

The MPC-32 was not explicitly analyzed for damaged fuel or fuel debris in this chapter. However, based on the analysis described above for the MPC-24 and the MPC-68, it can be concluded that the shielding performance of the MPC-32 will not be significantly affected by the storage of damaged fuel.

5.4.3 Site Boundary Evaluation

NUREG-1536 [5.2.1] states that detailed calculations need not be presented since SAR Chapter 12 assigns ultimate compliance responsibilities to the site licensee. Therefore, this subsection describes, by example, the general methodology for performing site boundary dose calculations. The site-specific fuel characteristics, burnup, cooling time, and the site characteristics would be factored into the evaluation performed by the licensee.

As an example of the methodology, the dose from a single HI-STORM overpack loaded with an MPC-24 and various arrays of loaded HI-STORMs at distances equal to and greater than 100 meters were evaluated with MCNP. In the model, the casks were placed on an infinite slab of dirt to account for earth-shine effects. The atmosphere was represented by dry air at a uniform density corresponding to 20 degrees C. The height of air modeled was 700 meters. This is more than sufficient to properly account for skyshine effects. The models included either 500 or 1050 meters of air around the cask. Based on the behavior of the dose rate as a function of distance, 50 meters of air, beyond the detector locations, is sufficient to account for back-scattering. Therefore, the HI-STORM MCNP off-site dose models account for back scattering by including more than 50 meters of air beyond the detector locations for all cited dose rates. Since gamma back-scattering has an effect on the off-site dose, it is recommended that the site-specific evaluation under 10CFR72.212 include at least 50 to 100 meters of air, beyond the detector locations, in the calculational models.

The MCNP calculations of the off-site dose used a two-stage process. In the first stage a binary surface source file (MCNP terminology) containing particle track information was written for particles crossing the outer radial and top surfaces of the HI-STORM overpack. In the second stage of the calculation, this surface source file was used with the particle tracks originating on the outer edge of the overpack and the dose rate was calculated at the desired location (hundreds of meters away from the overpack). The results from this two-stage process are statistically the same as the results from a single calculation. However, the advantage of the two-stage process is that each stage can be optimized independently.

The annual dose, assuming 100% occupancy (8760 hours), at 350 meters from a single HI-STORM 100S Version B cask is presented in Table 5.4.6 for the design basis burnup and cooling time analyzed. This table indicates that the dose due to neutrons is 2.8 % of the total dose. This is an important observation because it implies that simplistic analytical methods such as point kernel techniques may not properly account for the neutron transmissions and could lead to low estimates of the site boundary dose.

The annual dose, assuming 8760 hour occupancy, at distance from an array of casks was calculated in three steps.

1. The annual dose from the radiation leaving the side of the HI-STORM 100S Version B overpack was calculated at the distance desired. Dose value = A.
2. The annual dose from the radiation leaving the top of the HI-STORM 100S Version B overpack was calculated at the distance desired. Dose value = B.
3. The annual dose from the radiation leaving the side of a HI-STORM 100S Version B overpack, when it is behind another cask, was calculated at the distance desired. The casks have an assumed 15-foot pitch. Dose value = C.

The doses calculated in the steps above are listed in Table 5.4.7 for the bounding burnup and cooling time of 60,000 MWD/MTU and 3-year cooling. Using these values, the annual dose (at the center of the long side) from an arbitrary 2 by Z array of HI-STORM 100S Version B overpacks can easily be calculated. The following formula describes the method.

Z = number of casks along long side

$$\text{Dose} = ZA + 2ZB + ZC$$

As an example, the dose from a 2x3 array at 450 meters is presented.

1. The annual dose from the side of a single cask: Dose A = 6.81
2. The annual dose from the top of a single cask: Dose B = 1.78E-2
3. The annual dose from the side of a cask positioned behind another cask:
Dose C = 1.36

Using the formula shown above (Z=3), the total dose at 450 meters from a 2x3 array of HI-STORM overpacks is 24.62 mrem/year, assuming a 8760 hour occupancy.

An important point to notice here is that the dose from the side of the back row of casks is approximately 16 % of the total dose. This is a significant contribution and one that would probably not be accounted for properly by simpler methods of analysis.

The results for various typical arrays of HI-STORM overpacks can be found in Section 5.1. While the off-site dose analyses were performed for typical arrays of casks containing design basis fuel, compliance with the requirements of 10CFR72.104(a) can only be demonstrated on a site-specific basis. Therefore, a site-specific evaluation of dose at the controlled area boundary must be performed for each ISFSI in accordance with 10CFR72.212. The site-specific evaluation will consider the site-specific characteristics (such as exposure duration and the number of casks deployed), dose from other portions of the facility and the specifics of the fuel being stored (burnup and cooling time).

5.4.4 Stainless Steel Clad Fuel Evaluation

Table 5.4.8 presents the dose rates at the center of the HI-STORM 100 overpack, adjacent and at one meter distance, from the stainless steel clad fuel. These dose rates, when compared to Tables 5.1.1 through 5.1.6, are similar to the dose rates from the design basis zircaloy clad fuel, indicating that these fuel assemblies are acceptable for storage.

As described in Section 5.2.3, it would be incorrect to compare the total source strength from the stainless steel clad fuel assemblies to the source strength from the design basis zircaloy clad fuel assemblies since these assemblies do not have the same active fuel length and since there is a significant gamma source from Cobalt-60 activation in the stainless steel. Therefore it is necessary to calculate the dose rates from the stainless steel clad fuel and compare them to the dose rates from the zircaloy clad fuel. In calculating the dose rates, the source term for the stainless steel fuel was calculated with an artificial active fuel length of 144 inches to permit a simple comparison of dose rates from stainless steel clad fuel and zircaloy clad fuel at the center of the HI-STORM 100 overpack. Since the true active fuel length is shorter than 144 inches and since the end fitting masses of the stainless steel clad fuel are assumed to be identical to the end fitting masses of the zircaloy clad fuel, the dose rates at the other locations on the overpack are bounded by the dose rates from the design basis zircaloy clad fuel, and therefore, no additional dose rates are presented.

5.4.5 Mixed Oxide Fuel Evaluation

The source terms calculated for the Dresden 1 GE 6x6 MOX fuel assemblies can be compared to the source terms for the BWR design basis zircaloy clad fuel assembly (GE 7x7) which demonstrates that the MOX fuel source terms are bounded by the design basis source terms and no additional shielding analysis is needed.

Since the active fuel length of the MOX fuel assemblies is shorter than the active fuel length of the design basis fuel, the source terms must be compared on a per inch basis. Dividing the total fuel gamma source for the MOX fuel in Table 5.2.22 by the 110 inch active fuel height provides a gamma source per inch of $2.36\text{E}+12$ photons/s. Dividing the total neutron source for the MOX fuel assemblies in Table 5.2.23 by 110 inches provides a neutron source strength per inch of $3.06\text{E}+5$ neutrons/s. These values are both bounded by the BWR design basis fuel gamma source

per inch and neutron source per inch values of $1.08\text{E}+13$ photons/s and $9.17\text{E}+5$ neutrons/s for 40,000 MWD/MTU and 5 year cooling. These BWR design basis values were calculated by dividing the total source strengths for 40,000 MWD/MTU and 5 year cooling by the active fuel length of 144 inches. This comparison shows that the MOX fuel source terms are bound by the design basis source terms. Therefore, no explicit analysis of dose rates is provided for MOX fuel.

Since the MOX fuel assemblies are Dresden Unit 1 6x6 assemblies, they can also be considered as damaged fuel. Using the same methodology as described in Section 5.4.2.1, the source term for the MOX fuel is calculated on a per inch basis assuming a post accident rubble height of 80 inches. The resulting gamma and neutron source strengths are $3.25\text{E}+12$ photons/s and $4.21\text{E}+5$ neutrons/s. These values are also bounded by the design basis fuel gamma source per inch and neutron source per inch. Therefore, no explicit analysis of dose rates is provided for MOX fuel in a post accident configuration.

5.4.6 Non-Fuel Hardware

As discussed in Section 5.2.4, non-fuel hardware in the form of BPRAs, TPDs, CRAs, and APSRs are permitted for storage, integral with a PWR fuel assembly, in the HI-STORM 100 System. Since each of these devices occupy the same location within an assembly (i.e., the guide tubes), only one of these devices will be present in a given assembly. ITTRs, which are installed after core discharge and do not contain radioactive material, may also be stored in the assembly. BPRAs, TPDs, and ITTRs are authorized for unrestricted storage in an MPC. The CRAs are restricted to the center twelve locations in an MPC while the APSRs are restricted to the center four locations in the MPC-24, MPC-24E, MPC-24EF and the center twelve locations in the MPC-32. The calculation of the source term and a description of the bounding fuel devices was provided in Section 5.2.4. The dose rate due to BPRAs and TPDs being stored in a fuel assembly was explicitly calculated. Table 5.4.15 provides the dose rates at various locations on the surface and one meter from the 100-ton HI-TRAC due to the BPRAs and TPDs for the MPC-24 and MPC-32. These results were added to the totals in the other table to provide the total dose rate with BPRAs. Table 5.4.15 indicates that the dose rates from BPRAs bound the dose rates from TPDs.

The analyses in this chapter that consider presence of BPRAs assume that a full-length rod with burnable poison is present in all principal locations. In reality, many BPRAs contain full-length poison rods in some locations, and thimble rodlets in others. The burnup and cooling time combinations listed in Table 2.1.25 for BPRAs and TPDs were selected to ensure the Co-60 activity of those devices is below the value of 895 Ci (BPRAs) and 50 Ci (TPDs). These activities are used in the dose evaluations presented in this chapter. Apart from the total activity, the axial distribution of the material in those devices is important for the dose rates. This axial distribution is shown in Table 5.2.30 (masses) and 5.2.31 (activities). It can be observed from Table 5.2.31, while TPDs have a lower overall activity, their activity in the gas plenum region of the assembly is higher compared to that of the BPRAs. These activities were used to calculate the dose rates in Table 5.4.15. The results in this table show that the maximum dose effect for BPRAs is at the

HOLTEC INTERNATIONAL COPYRIGHTED MATERIAL

HI-STORM FSAR
REPORT HI-2002444

5.4-11

Rev. 11

side of the cask, while the maximum dose effect of TPDs is near and on the top of the cask. Nevertheless, Table 5.4.15 demonstrates that even near and on the top of the cask, the TPD doses are bounded by the BPRAs doses. It is to be noted that BPRAs with several thimble plugs may result higher dose rate near and on the top of the cask than that reported in Table 5.4.15. However, the potential local increase in dose near and on the top of the cask due the presence of several thimble plug rodlets instead of full length BPRAs rods would be more than compensated by the reduction of the dose from the side of the cask at larger distances. Therefore, using BPRAs with all burnable poison rods in the analyses that demonstrate compliance with the site boundary dose limits would be bounding, and hence the burnup and cooling time combinations for BPRAs in Table 2.1.25 are conservative.

As discussed in Section 5.2.4, two different configurations were analyzed for CRAs and three different configurations were analyzed for APSRs. The dose rate due to CRAs and APSRs was explicitly calculated for dose locations around the 100-ton HI-TRAC. Tables 5.4.16 and 5.4.17 provide the results for the different configurations of CRAs and APSRs, respectively, in the MPC-24 and MPC-32. These results indicate the dose rate on the radial surfaces of the overpack due to the storage of these devices is less than the dose rate from BPRAs (except for the surface dose rate at the bottom, where the value for the CRA is comparable to or higher than the value from the BPRAs, depending on the CRA configuration) and the dose rate out the top of the overpack is essentially 0. The latter is due to the fact that CRAs and APSRs do not achieve significant activation in the upper portion of the devices due to the manner in which they are utilized during normal reactor operations. In contrast, the dose rate out the bottom of the overpack is substantial due to these devices. However, these dose rates occur in an area (below the pool lid and transfer doors) which is not normally occupied. Therefore, even though the dose rates calculated (using a very conservative source term evaluation) are very high, they do not pose a risk from an operations perspective because they are localized in nature. Section 5.1.1 provides additional discussion on the acceptability of the relatively high localized doses on the bottom of the HI-TRACs.

It has to be noted that when twelve CRAs or APSRs are placed in a basket, not all of them are shielded equally well: the components placed in the center four locations have a better shielding than the eight components placed around them. The dose contribution per component will therefore be lower for components placed in the center four locations. It is therefore recommended from an ALARA perspective to minimize the number of CRAs and APSRs per basket if possible, and place the components close to the center of the basket.

5.4.7 Dresden Unit 1 Antimony-Beryllium Neutron Sources

Dresden Unit 1 has antimony-beryllium neutron sources which are placed in the water rod location of their fuel assemblies. These sources are steel rods which contain a cylindrical antimony-beryllium source which is 77.25 inches in length. The steel rod is approximately 95 inches in length. Information obtained from Dresden Unit 1 characterizes these sources in the following manner: "About one-quarter pound of beryllium will be employed as a special neutron

source material. The beryllium produces neutrons upon gamma irradiation. The gamma rays for the source at initial start-up will be provided by neutron-activated antimony (about 865 curies). The source strength is approximately $1E+8$ neutrons/second.”

As stated above, beryllium produces neutrons through gamma irradiation and in this particular case antimony is used as the gamma source. The threshold gamma energy for producing neutrons from beryllium is 1.666 MeV. The outgoing neutron energy increases as the incident gamma energy increases. Sb-124, which decays by Beta decay with a half life of 60.2 days, produces a gamma of energy 1.69 MeV which is just energetic enough to produce a neutron from beryllium. Approximately 54% of the Beta decays for Sb-124 produce gammas with energies greater than or equal to 1.69 MeV. Therefore, the neutron production rate in the neutron source can be specified as $5.8E-6$ neutrons per gamma ($1E+8/865/3.7E+10/0.54$) with energy greater than 1.666 MeV or $1.16E+5$ neutrons/curie ($1E+8/865$) of Sb-124.

With the short half life of 60.2 days all of the initial Sb-124 is decayed and any Sb-124 that was produced while the neutron source was in the reactor is also decayed since these neutron sources are assumed to have the same minimum cooling time as the Dresden 1 fuel assemblies (array classes 6x6A, 6x6B, 6x6C, and 8x8A) of 18 years. Therefore, there are only two possible gamma sources which can produce neutrons from this antimony-beryllium source. The first is the gammas from the decay of fission products in the fuel assemblies in the MPC. The second gamma source is from Sb-124 which is being produced in the MPC from neutron activation from neutrons from the decay of fission products.

MCNP calculations were performed to determine the gamma source as a result of decay gammas from fuel assemblies and Sb-124 activation. The calculations explicitly modeled the 6x6 fuel assembly described in Table 5.2.2. A single fuel rod was removed and replaced by a guide tube. In order to determine the amount of Sb-124 that is being activated from neutrons in the MPC it was necessary to estimate the amount of antimony in the neutron source. The O.D. of the source was assumed to be the I.D. of the steel rod encasing the source (0.345 in.). The length of the source is 77.25 inches. The beryllium is assumed to be annular in shape encompassing the antimony. Using the assumed O.D. of the beryllium and the mass and length, the I.D. of the beryllium was calculated to be 0.24 inches. The antimony is assumed to be a solid cylinder with an O.D. equal to the I.D. of the beryllium. These assumptions are conservative since the antimony and beryllium are probably encased in another material which would reduce the mass of antimony. A larger mass of antimony is conservative since the calculated activity of Sb-124 is directly proportional to the initial mass of antimony.

The number of gammas from fuel assemblies with energies greater than 1.666 MeV entering the 77.25 inch long neutron source was calculated to be $1.04E+8$ gammas/sec which would produce a neutron source of 603.2 neutrons/sec ($1.04E+8 * 5.8E-6$). The steady state amount of Sb-124 activated in the antimony was calculated to be 39.9 curies. This activity level would produce a neutron source of $4.63E+6$ neutrons/sec ($39.9 * 1.16E+5$) or $6.0E+4$ neutrons/sec/inch ($4.63E+6/77.25$). These calculations conservatively neglect the reduction in antimony and

beryllium which would have occurred while the neutron sources were in the core and being irradiated at full reactor power.

Since this is a localized source (77.25 inches in length) it is appropriate to compare the neutron source per inch from the design basis Dresden Unit 1 fuel assembly, 6x6, containing an Sb-Be neutron source to the design basis fuel neutron source per inch. This comparison, presented in Table 5.4.18, demonstrates that a Dresden Unit 1 fuel assembly containing an Sb-Be neutron source is bounded by the design basis fuel.

As stated above, the Sb-Be source is encased in a steel rod. Therefore, the gamma source from the activation of the steel was considered assuming a burnup of 120,000 MWD/MTU which is the maximum burnup assuming the Sb-Be source was in the reactor for the entire 18 year life of Dresden Unit 1. The cooling time assumed was 18 years which is the minimum cooling time for Dresden Unit 1 fuel. The source from the steel was bounded by the design basis fuel assembly. In conclusion, storage of a Dresden Unit 1 Sb-Be neutron source in a Dresden Unit 1 fuel assembly is acceptable and bounded by the current analysis.

5.4.8 Thoria Rod Canister

Based on a comparison of the gamma spectra from Tables 5.2.37 and 5.2.7 for the thoria rod canister and design basis 6x6 fuel assembly, respectively, it is difficult to determine if the thoria rods will be bounded by the 6x6 fuel assemblies. However, it is obvious that the neutron spectra from the 6x6, Table 5.2.18, bounds the thoria rod neutron spectra, Table 5.2.38, with a significant margin. In order to demonstrate that the gamma spectrum from the single thoria rod canister is bounded by the gamma spectrum from the design basis 6x6 fuel assembly, the gamma dose rate on the outer radial surface of the 100-ton HI-TRAC and the HI-STORM overpack was estimated conservatively assuming an MPC full of thoria rod canisters. This gamma dose rate was compared to an estimate of the dose rate from an MPC full of design basis 6x6 fuel assemblies. The gamma dose rate from the 6x6 fuel was higher for the 100-ton HI-TRAC and only 15% lower for the HI-STORM overpack than the dose rate from an MPC full of thoria rod canisters. This in conjunction with the significant margin in neutron spectrum and the fact that there is only one thoria rod canister clearly demonstrates that the thoria rod canister is acceptable for storage in the MPC-68 or the MPC-68F.

5.4.9 Regionalized Loading Dose Rate Evaluation

Section 2.1.9 describes the regionalized loading scheme available in the HI-STORM 100 system. Depending on the choice of X (the ratio of inner region assembly heat load to outer region assembly heat load), higher heat load fuel (higher burnup and shorter cooling time) may be placed in either region 1 or region 2. If X is greater than 1, the higher heat load fuel is placed in region 1 and shielded by lower heat load fuel in region 2. This configuration produces the lowest dose rates since the older colder fuel is being used as shielding for the younger hotter fuel. If X is less than 1, then the younger hotter fuel is placed on the periphery of the basket and the older

colder fuel is placed on the interior of the basket. This configuration will result in higher radial dose rates than for configurations with X greater than or equal to 1. In order to perform a bounding shielding analysis, the burnup and cooling time combinations listed in Section 5.1 were chosen to bound all values of X. All fuel assemblies in an MPC were assumed to have the same burnup and cooling time in the shielding analysis. This approach results in dose rates calculated in this chapter that bound all allowable regionalized and uniform loading burnup and cooling time combinations.

HOLTEC INTERNATIONAL COPYRIGHTED MATERIAL

HI-STORM FSAR
REPORT HI-2002444

5.4-15

Rev. 11

Table 5.4.1

FLUX-TO-DOSE CONVERSION FACTORS
(FROM [5.4.1])

Gamma Energy (MeV)	(rem/hr)/ (photon/cm ² -s)
0.01	3.96E-06
0.03	5.82E-07
0.05	2.90E-07
0.07	2.58E-07
0.1	2.83E-07
0.15	3.79E-07
0.2	5.01E-07
0.25	6.31E-07
0.3	7.59E-07
0.35	8.78E-07
0.4	9.85E-07
0.45	1.08E-06
0.5	1.17E-06
0.55	1.27E-06
0.6	1.36E-06
0.65	1.44E-06
0.7	1.52E-06
0.8	1.68E-06
1.0	1.98E-06
1.4	2.51E-06
1.8	2.99E-06
2.2	3.42E-06

Table 5.4.1 (continued)

FLUX-TO-DOSE CONVERSION FACTORS
(FROM [5.4.1])

Gamma Energy (MeV)	(rem/hr)/ (photon/cm ² -s)
2.6	3.82E-06
2.8	4.01E-06
3.25	4.41E-06
3.75	4.83E-06
4.25	5.23E-06
4.75	5.60E-06
5.0	5.80E-06
5.25	6.01E-06
5.75	6.37E-06
6.25	6.74E-06
6.75	7.11E-06
7.5	7.66E-06
9.0	8.77E-06
11.0	1.03E-05
13.0	1.18E-05
15.0	1.33E-05

Table 5.4.1 (continued)

FLUX-TO-DOSE CONVERSION FACTORS
(FROM [5.4.1])

Neutron Energy (MeV)	Quality Factor	(rem/hr) [†] /(n/cm ² -s)
2.5E-8	2.0	3.67E-6
1.0E-7	2.0	3.67E-6
1.0E-6	2.0	4.46E-6
1.0E-5	2.0	4.54E-6
1.0E-4	2.0	4.18E-6
1.0E-3	2.0	3.76E-6
1.0E-2	2.5	3.56E-6
0.1	7.5	2.17E-5
0.5	11.0	9.26E-5
1.0	11.0	1.32E-4
2.5	9.0	1.25E-4
5.0	8.0	1.56E-4
7.0	7.0	1.47E-4
10.0	6.5	1.47E-4
14.0	7.5	2.08E-4
20.0	8.0	2.27E-4

† Includes the Quality Factor.

HOLTEC INTERNATIONAL COPYRIGHTED MATERIAL

HI-STORM FSAR
REPORT HI-2002444

5.4-18

Rev. 11

Table 5.4.2

DOSE RATES FOR THE 100-TON HI-TRAC FOR THE FULLY FLOODED MPC
CONDITION WITH AN EMPTY NEUTRON SHIELD
MPC-24 DESIGN BASIS ZIRCALOY CLAD FUEL AT
60,000 MWD/MTU AND 3-YEAR COOLING

Dose Point [†] Location	Fuel Gammas ^{††} (mrem/hr)	⁶⁰ Co Gammas (mrem/hr)	Neutrons (mrem/hr)	Totals (mrem/hr)	Totals with BPRAs (mrem/hr)
ADJACENT TO THE 100-TON HI-TRAC					
1	44.75	370.31	55.57	470.63	473.46
2	2649.74	0.79	810.25	3460.78	3664.65
3	9.98	484.21	11.35	505.54	637.13
4	39.13	367.92	2.10	409.15	511.41
5 (pool lid)	126.99	2071.23	5.62	2203.84 ^{†††}	2214.03
ONE METER FROM THE 100-TON HI-TRAC					
1	351.97	74.73	115.53	542.22	568.65
2	1171.07	7.08	265.57	1443.73	1533.97
3	140.14	117.78	47.64	305.55	349.87

Note: MPC internal water level is 10 inches below the MPC lid.

[†] Refer to Figures 5.1.2 and 5.1.4.

^{††} Gammas generated by neutron capture are included with fuel gammas.

^{†††} Cited dose rates correspond to the cask center. Figures 5.1.6, 5.1.7, and 5.1.11 illustrate the substantial reduction in dose rates moving radially outward from the axial center of the HI-TRAC.

Table 5.4.3

DOSE RATES FOR THE 100-TON HI-TRAC FOR THE FULLY FLOODED MPC
CONDITION WITH A FULL NEUTRON SHIELD
MPC-24 DESIGN BASIS ZIRCALOY CLAD FUEL AT
60,000 MWD/MTU AND 3-YEAR COOLING

Dose Point [†] Location	Fuel Gammas ^{††} (mrem/hr)	⁶⁰ Co Gammas (mrem/hr)	Neutrons (mrem/hr)	Totals (mrem/hr)	Totals with BPRAs (mrem/hr)
ADJACENT TO THE 100-TON HI-TRAC					
1	34.56	318.37	6.08	359.01	361.11
2	1565.21	0.50	53.06	1618.77	1734.33
3	6.38	483.03	1.07	490.48	621.41
4	39.09	367.91	1.93	408.92	511.18
5 (pool lid)	126.63	2071.47	5.41	2203.51 ^{†††}	2213.68
ONE METER FROM THE 100-TON HI-TRAC					
1	202.31	49.47	7.09	258.86	273.65
2	681.82	3.93	19.97	705.72	756.28
3	80.54	81.26	2.41	164.21	193.09

Note: MPC internal water level is 10 inches below the MPC lid.

[†] Refer to Figures 5.1.2 and 5.1.4.

^{††} Gammas generated by neutron capture are included with fuel gammas.

^{†††} Cited dose rates correspond to the cask center. Figures 5.1.6, 5.1.7, and 5.1.11 illustrate the substantial reduction in dose rates moving radially outward from the axial center of the HI-TRAC.

Table 5.4.4

[INTENTIONALLY DELETED]

Table 5.4.5

[INTENTIONALLY DELETED]

HOLTEC INTERNATIONAL COPYRIGHTED MATERIAL

HI-STORM FSAR
REPORT HI-2002444

5.4-21

Rev. 11

Table 5.4.6

ANNUAL DOSE AT 350 METERS FROM A SINGLE
HI-STORM 100S VERSION B OVERPACK WITH AN MPC-24 WITH DESIGN BASIS
ZIRCALOY CLAD FUEL[†]

Dose Component	60,000 MWD/MTU 3-Year Cooling (mrem/yr)
Fuel gammas ^{††}	17.54
⁶⁰ Co Gammas	1.18
Neutrons	0.54
Total	19.26

† 8760 hour annual occupancy is assumed.

†† Gammas generated by neutron capture are included with fuel gammas.

Table 5.4.7

DOSE VALUES USED IN CALCULATING ANNUAL DOSE FROM
 VARIOUS HI-STORM 100S VERSION B ISFSI CONFIGURATIONS
 60,000 MWD/MTU AND 3-YEAR COOLING ZIRCALOY CLAD FUEL[†]

Distance	A Side of Overpack (mrem/yr)	B Top of Overpack (mrem/yr)	C Side of Shielded Overpack (mrem/yr)
100 meters	880.47	2.79	176.09
150 meters	299.26	1.04	59.85
200 meters	129.22	0.48	25.84
250 meters	64.50	0.22	12.90
300 meters	34.11	0.12	6.82
350 meters	19.20	6.06E-02	3.84
400 meters	11.26	3.25E-02	2.25
450 meters	6.81	1.78E-02	1.36
500 meters	4.22	1.07E-02	0.84
550 meters	2.71	6.94E-03	0.54
600 meters	1.74	4.13E-03	0.35

[†] 8760 hour annual occupancy is assumed.

Table 5.4.8

DOSE RATES AT THE CENTERLINE OF THE OVERPACK FOR
DESIGN BASIS STAINLESS STEEL CLAD FUEL
WITHOUT BPRAs

Dose Point [†] Location	Fuel Gammas ^{††} (mrem/hr)	⁶⁰ Co Gammas (mrem/hr)	Neutrons (mrem/hr)	Totals (mrem/hr)
MPC-24 (40,000 MWD/MTU AND 8-YEAR COOLING)				
2 (Adjacent)	36.97	0.02	1.11	38.10
2 (One Meter)	18.76	0.17	0.50	19.43
MPC-32 (40,000 MWD/MTU AND 9-YEAR COOLING)				
2 (Adjacent)	37.58	0.00	1.49	39.08
2 (One Meter)	18.74	0.25	0.58	19.57
MPC-68 (22,500 MWD/MTU AND 10-YEAR COOLING)				
2 (Adjacent)	17.79	0.01	0.10	17.90
2 (One Meter)	8.98	0.13	0.04	9.15

† Refer to Figure 5.1.1.

†† Gammas generated by neutron capture are included with fuel gammas.

HOLTEC INTERNATIONAL COPYRIGHTED MATERIAL

HI-STORM FSAR
REPORT HI-2002444

5.4-24

Rev. 11

Table 5.4.9

DOSE RATES FROM THE 100-TON HI-TRAC FOR NORMAL CONDITIONS
MPC-68 DESIGN BASIS ZIRCALOY CLAD FUEL AT
50,000 MWD/MTU AND 3-YEAR COOLING

Dose Point Location	Fuel Gammas (mrem/hr)	(n, γ) Gammas (mrem/hr)	⁶⁰ Co Gammas (mrem/hr)	Neutrons (mrem/hr)	Totals (mrem/hr)
ADJACENT TO THE 100-TON HI-TRAC					
1	118.31	25.51	1260.91	340.66	1745.39
2	2638.99	125.79	0.80	227.40	2992.98
3	7.38	2.57	833.34	147.88	991.17
3 (temp)	4.33	4.53	408.34	2.70	419.89
4	25.26	0.90	494.35	195.30	715.82
4 (outer)	7.49	0.70	132.37	124.46	265.02
5 (pool lid)	351.88	31.12	5646.34	2040.15	8069.50
5 (transfer lid)	509.02	1.43	8507.35	1288.83	10306.63
5 (t-outer)	187.09	0.61	750.08	479.11	1416.90
ONE METER FROM THE 100-TON HI-TRAC					
1	359.24	15.46	117.76	60.21	552.67
2	1134.59	35.59	8.69	78.41	1257.27
3	88.49	6.19	178.43	16.85	289.97
3 (temp)	88.38	6.52	142.94	8.14	245.97
4	7.94	0.52	151.01	47.61	207.07
5 (transfer lid)	260.67	0.62	3774.45	344.08	4379.82
5 (t-outer)	32.63	1.12	318.78	97.39	449.92

Notes:

- Refer to Figures 5.1.2 and 5.1.4 for dose locations.
- Dose location 3(temp) represents dose location 3 with temporary shielding installed.
- Dose location 4(outer) is the radial segment at dose location 4 which is 18-30 inches from the center of the overpack.
- Dose location 5 (t-outer) is the radial segment at dose location 5 (transfer lid) which is 30-42 and 54-66 inches from the center of the lid for the adjacent and one meter locations, respectively. The inner radius of the HI-TRAC is 34.375 in. and the outer radius of the water jacket is 44.375 in.
- Dose rate based on no water within the MPC. For the majority of the duration that the HI-TRAC pool lid is installed, the MPC cavity will be flooded with water. The water within the MPC greatly reduces the dose rate.

HOLTEC INTERNATIONAL COPYRIGHTED MATERIAL

HI-STORM FSAR
REPORT HI-2002444

5.4-25

Rev. 11

Table 5.4.10

[INTENTIONALLY DELETED]

HOLTEC INTERNATIONAL COPYRIGHTED MATERIAL

HI-STORM FSAR
REPORT HI-2002444

5.4-26

Rev. 11

Table 5.4.11

DOSE RATES FROM THE 100-TON HI-TRAC FOR NORMAL CONDITIONS
MPC-32 DESIGN BASIS ZIRCALOY CLAD FUEL
45,000 MWD/MTU AND 3-YEAR COOLING

Dose Point Location	Fuel Gammas (mrem/hr)	(n, γ) Gammas (mrem/hr)	⁶⁰ Co Gammas (mrem/hr)	Neutrons (mrem/hr)	Totals (mrem/hr)	Totals with BPRAs (mrem/hr)
ADJACENT TO THE 100-TON HI-TRAC						
1	123.09	17.99	1134.82	253.68	1529.57	1539.91
2	3059.28	77.64	1.63	145.58	3284.12	3576.87
3	42.51	3.43	703.72	203.47	953.12	1178.63
4	102.68	1.55	527.34	253.44	885.02	1064.21
4 (outer)	28.17	0.91	132.30	174.27	335.65	380.68
5 (pool)	745.11	26.66	6237.41	1665.29	8674.47	8757.27
5 (transfer)	1366.50	1.04	9401.97	966.70	11736.20	11837.01
5 (t-outer)	246.52	0.48	787.00	363.83	1397.82	1418.02
ONE METER FROM THE 100-TON HI-TRAC						
1	407.43	10.23	168.91	42.45	629.02	667.20
2	1350.21	24.30	12.79	54.21	1441.51	1571.36
3	176.77	5.64	144.81	19.97	347.18	414.23
4	31.95	0.40	157.25	63.15	252.75	305.95
5 (transfer)	567.40	0.23	3723.34	260.88	4551.86	4598.19
5 (t-outer)	58.97	0.96	330.25	76.48	466.67	471.29

Notes:

- Refer to Figures 5.1.2 and 5.1.4 for dose locations.
- Dose location 4(outer) is the radial segment at dose location 4 which is 18-30 inches from the center of the overpack.
- Dose location 5 (t-outer) is the radial segment at dose location 5 (transfer lid) which is 30-42 and 54-66 inches from the center of the lid for the adjacent and one meter locations, respectively. The inner radius of the HI-TRAC is 34.375 in. and the outer radius of the water jacket is 44.375 in.
- Dose rate based on no water within the MPC. For the majority of the duration that the HI-TRAC pool lid is installed, the MPC cavity will be flooded with water. The water within the MPC greatly reduces the dose rate.

HOLTEC INTERNATIONAL COPYRIGHTED MATERIAL

HI-STORM FSAR
REPORT HI-2002444

5.4-27

Rev. 11

Table 5.4.12

[INTENTIONALLY DELETED]

HOLTEC INTERNATIONAL COPYRIGHTED MATERIAL

HI-STORM FSAR
REPORT HI-2002444

5.4-28

Rev. 11

Table 5.4.13

DOSE RATES FROM THE 100-TON HI-TRAC FOR ACCIDENT CONDITIONS
 WITH FOUR DAMAGED FUEL CONTAINERS
 MPC-24 DESIGN BASIS ZIRCALOY CLAD FUEL
 60,000 MWD/MTU AND 3-YEAR COOLING
 WITHOUT BPRAs

Dose Point [†] Location	Fuel Gammas (mrem/hr)	(n, γ) Gammas (mrem/hr)	⁶⁰ Co Gammas (mrem/hr)	Neutrons (mrem/hr)	Totals (mrem/hr)
ADJACENT TO THE 100-TON HI-TRAC					
1	162.53	40.07	958.00	607.90	1768.50
2	3154.37	145.11	1.14	264.13	3564.75
3	47.06	9.00	528.22	583.57	1167.85
ONE METER FROM THE 100-TON HI-TRAC					
1	449.03	20.58	142.41	92.37	704.39
2	1404.60	44.91	11.27	99.48	1560.26
3	202.22	11.75	118.30	54.30	386.56

[†] Refer to Figures 5.1.2 and 5.1.4.

Table 5.4.14

DOSE RATES FROM THE 100-TON HI-TRAC FOR ACCIDENT CONDITIONS
 WITH SIXTEEN DAMAGED FUEL CONTAINERS
 MPC-68 DESIGN BASIS ZIRCALOY CLAD FUEL
 50,000 MWD/MTU AND 3-YEAR COOLING

Dose Point [†] Location	Fuel Gammas (mrem/hr)	(n, γ) Gammas (mrem/hr)	⁶⁰ Co Gammas (mrem/hr)	Neutrons (mrem/hr)	Totals (mrem/hr)
ADJACENT TO THE 100-TON HI-TRAC					
1	276.49	36.57	1260.91	629.42	2203.39
2	2488.31	126.39	0.80	213.81	2829.31
3	9.10	5.48	833.34	324.77	1172.69
ONE METER FROM THE 100-TON HI-TRAC					
1	417.32	19.09	117.76	90.45	644.62
2	1091.56	38.82	8.69	85.73	1224.79
3	121.49	8.49	178.43	33.62	342.02

[†] Refer to Figures 5.1.2 and 5.1.4.

Table 5.4.15

DOSE RATES DUE TO BPRAs AND TPDs FROM THE 100-TON HI-TRAC
FOR NORMAL CONDITIONS

Dose Point Location	MPC-24		MPC-32	
	BPRAs (mrem/hr)	TPDs (mrem/hr)	BPRAs (mrem/hr)	TPDs (mrem/hr)
ADJACENT TO THE 100-TON HI-TRAC				
1	8.54	0.00	10.34	0.01
2	247.24	0.03	292.75	0.04
3	148.53	125.75	225.50	188.14
3 (temp)	68.15	56.21	93.63	77.00
4	124.50	106.71	179.19	156.14
4 (outer)	31.33	27.12	45.02	39.33
5 (pool lid)	64.77	0.00	82.79	0.01
5 (transfer lid)	96.84	0.00	100.81	0.00
5 (t-outer)	21.47	0.00	20.20	0.00
ONE METER FROM THE 100-TON HI-TRAC				
1	32.48	0.18	38.18	0.24
2	109.47	1.20	129.85	1.63
3	49.43	38.93	67.05	55.11
3 (temp)	44.57	35.01	59.32	48.95
4	38.57	33.37	53.20	47.19
5 (transfer lid)	39.13	0.00	46.33	0.00
5 (t-outer)	3.90	0.00	4.63	0.00

Notes:

- Refer to Figures 5.1.2 and 5.1.4 for dose locations.
- Dose location 3(temp) represents dose location 3 with temporary shielding installed.
- Dose location 4(outer) is the radial segment at dose location 4 which is 18-30 inches from the center of the overpack.
- Dose location 5 (t-outer) is the radial segment at dose location 5 (transfer lid) which is 30-42 and 54-66 inches from the center of the lid for the adjacent and one meter locations, respectively. The inner radius of the HI-TRAC is 34.375 in. and the outer radius of the water jacket is 44.375 in.
- Dose rate based on no water within the MPC. For the majority of the duration that the HI-TRAC pool lid is installed, the MPC cavity will be flooded with water. The water within the MPC greatly reduces the dose rate.

HOLTEC INTERNATIONAL COPYRIGHTED MATERIAL

Table 5.4.16

DOSE RATES DUE TO CRAs FROM THE 100-TON HI-TRAC
FOR NORMAL CONDITIONS

Dose Point Location	MPC-24		MPC-32	
	Config. 1 (mrem/hr)	Config. 2 (mrem/hr)	Config. 1 (mrem/hr)	Config. 2 (mrem/hr)
ADJACENT TO THE 100-TON HI-TRAC				
1	49.65	8.99	25.25	5.12
2	3.15	0.08	0.12	0.01
3	0.00	0.00	0.00	0.00
4	0.00	0.00	0.00	0.00
5 (pool lid)	1061.33	213.34	1504.83	300.86
5 (transfer lid)	1846.04	349.09	2785.92	521.49
5 (t-outer)	36.32	5.82	15.21	2.76
ONE METER FROM THE 100-TON HI-TRAC				
1	28.42	3.59	5.11	0.97
2	13.64	1.19	0.67	0.09
3	0.20	0.02	0.02	0.00
4	0.00	0.00	0.00	0.00
5 (transfer lid)	545.93	100.60	638.62	119.05
5 (t-outer)	29.81	5.51	30.89	5.88

Notes:

- Refer to Figures 5.1.2 and 5.1.4 for dose locations.
- Dose location 5 (t-outer) is the radial segment at dose location 5 (transfer lid) which is 30-42 and 54-66 inches from the center of the lid for the adjacent and one meter locations, respectively. The inner radius of the HI-TRAC is 34.375 in. and the outer radius of the water jacket is 44.375 in.
- Dose rate based on no water within the MPC. For the majority of the duration that the HI-TRAC pool lid is installed, the MPC cavity will be flooded with water. The water within the MPC greatly reduces the dose rate.

HOLTEC INTERNATIONAL COPYRIGHTED MATERIAL

HI-STORM FSAR
REPORT HI-2002444

5.4-32

Rev. 11

Table 5.4.17

DOSE RATES DUE TO APSRs FROM THE 100-TON HI-TRAC
FOR NORMAL CONDITIONS

Dose Point Location	MPC-24			MPC-32		
	Config. 1 (mrem/hr)	Config. 2 (mrem/hr)	Config. 3 (mrem/hr)	Config. 1 (mrem/hr)	Config. 2 (mrem/hr)	Config. 3 (mrem/hr)
ADJACENT TO THE 100-TON HI-TRAC						
1	12.42	2.35	12.25	57.80	11.73	56.80
2	0.21	0.01	9.12	0.29	0.02	17.70
3	0.00	0.00	0.00	0.00	0.00	0.00
4	0.00	0.00	0.00	0.00	0.00	0.09
5 (pool lid)	1996.57	371.98	1941.51	3243.57	645.11	3698.77
5 (transfer)	3021.08	572.85	2994.54	5522.01	1035.17	5664.10
5 (t-outer)	3.41	0.54	3.57	33.25	5.97	31.46
ONE METER FROM THE 100-TON HI-TRAC						
1	2.73	0.46	3.49	11.69	2.22	11.36
2	0.61	0.07	3.31	1.55	0.20	6.53
3	0.02	0.00	0.04	0.05	0.01	0.08
4	0.00	0.00	0.00	0.00	0.00	0.09
5 (transfer)	458.06	84.81	444.44	1288.04	240.05	1211.44
5 (t-outer)	17.11	3.19	17.36	64.18	12.16	62.83

Notes:

- Refer to Figures 5.1.2 and 5.1.4 for dose locations.
- Dose location 5 (t-outer) is the radial segment at dose location 5 (transfer lid) which is 30-42 and 54-66 inches from the center of the lid for the adjacent and one meter locations, respectively. The inner radius of the HI-TRAC is 34.375 in. and the outer radius of the water jacket is 44.375 in.
- Dose rate based on no water within the MPC. For the majority of the duration that the HI-TRAC pool lid is installed, the MPC cavity will be flooded with water. The water within the MPC greatly reduces the dose rate.

HOLTEC INTERNATIONAL COPYRIGHTED MATERIAL

HI-STORM FSAR
REPORT HI-2002444

5.4-33

Rev. 11

Table 5.4.18

COMPARISON OF NEUTRON SOURCE PER INCH PER SECOND FOR
DESIGN BASIS 7X7 FUEL AND DESIGN BASIS DRESDEN UNIT 1 FUEL

Assembly	Active fuel length (inch)	Neutrons per sec per inch	Neutrons per sec per inch with Sb-Be source	Reference for neutrons per sec per inch
7x7 design basis	144	9.17E+5	N/A	40 GWD/MTU and 5 year cooling
6x6 design basis	110	2.0E+5	2.6E+5	Table 5.2.18
6x6 design basis MOX	110	3.06E+5	3.66E+5	Table 5.2.23

Table 5.4.19

DOSE RATES FROM THE HI-TRAC 100D FOR NORMAL CONDITIONS
MPC-32 DESIGN BASIS ZIRCALOY CLAD FUEL
35,000 MWD/MTU AND 3-YEAR COOLING

Dose Point Location	Fuel Gammas (mrem/hr)	(n, γ) Gammas (mrem/hr)	⁶⁰ Co Gammas (mrem/hr)	Neutrons (mrem/hr)	Totals (mrem/hr)	Totals with BPRAs (mrem/hr)
ADJACENT TO THE 100-TON HI-TRAC						
1	156.55	10.12	1558.18	77.72	1802.56	1818.78
2	2575.94	34.87	1.88	63.16	2675.84	2972.05
3	36.72	1.51	596.76	89.80	724.78	950.60
ONE METER FROM THE 100-TON HI-TRAC						
1	349.37	4.72	192.55	16.34	562.97	602.58
2	1120.77	10.83	12.08	22.98	1166.66	1297.14
3	146.00	2.46	124.89	8.66	282.02	350.18

Notes:

- Refer to Figure 5.1.4 for dose locations.
- Dose rate based on no water within the MPC. For the majority of the duration that the HI-TRAC pool lid is installed, the MPC cavity will be flooded with water. The water within the MPC greatly reduces the dose rate.

5.5 REGULATORY COMPLIANCE

Chapters 1 and 2 and this chapter of this FSAR describe in detail the shielding structures, systems, and components (SSCs) important to safety.

This chapter has evaluated these shielding SSCs important to safety and has assessed the impact on health and safety resulting from operation of an independent spent fuel storage installation (ISFSI) utilizing the HI-STORM 100 System.

It has been shown that the design of the shielding system of the HI-STORM 100 System is in compliance with 10CFR72 and that the applicable design and acceptance criteria including 10CFR20 have been satisfied. Thus, this shielding evaluation provides reasonable assurance that the HI-STORM 100 System will allow safe storage of spent fuel.

5.6 REFERENCES

- [5.1.1] J.F. Briesmeister, Ed., "MCNP - A General Monte Carlo N-Particle Transport Code, Version 4A." Los Alamos National Laboratory, LA-12625-M (1993).
- [5.1.2] O.W. Hermann, C.V. Parks, "SAS2H: A Coupled One-Dimensional Depletion and Shielding Analysis Module," NUREG/CR-0200, Revision 5, (ORNL/NUREG/CSD-2/V2/R5), Oak Ridge National Laboratory, September 1995.
- [5.1.3] O.W. Hermann, R.M. Westfall, "ORIGEN-S: SCALE System Module to Calculate Fuel Depletion, Actinide Transmutation, Fission Product Buildup and Decay, and Associated Radiation Source Terms," NUREG/CR-0200, Revision 5, (ORNL/NUREG/CSD-2/V2/R5), Oak Ridge National Laboratory, September 1995.
- [5.2.1] NUREG-1536, SRP for Dry Cask Storage Systems, USNRC, Washington, DC, January 1997.
- [5.2.2] A.G. Croff, M.A. Bjerke, G.W. Morrison, L.M. Petrie, "Revised Uranium-Plutonium Cycle PWR and BWR Models for the ORIGEN Computer Code," ORNL/TM-6051, Oak Ridge National Laboratory, September 1978.
- [5.2.3] A. Luksic, "Spent Fuel Assembly Hardware: Characterization and 10CFR 61 Classification for Waste Disposal," PNL-6906-vol. 1, Pacific Northwest Laboratory, June 1989.
- [5.2.4] J.W. Roddy et al., "Physical and Decay Characteristics of Commercial LWR Spent Fuel," ORNL/TM-9591/V1&R1, Oak Ridge National Laboratory, January 1996.
- [5.2.5] "Characteristics of Spent Fuel, High Level Waste, and Other Radioactive Wastes Which May Require Long-Term Isolation," DOE/RW-0184, U.S. Department of Energy, December 1987.
- [5.2.6] "Spent Nuclear Fuel Discharges from U.S. Reactors 1994," SR/CNEAF/96-01, Energy Information Administration, U.S. Department of Energy, February 1996.
- [5.2.7] "Characteristics Database System LWR Assemblies Database," DOE/RW-0184-R1, U.S. Department of Energy, July 1992.

HOLTEC INTERNATIONAL COPYRIGHTED MATERIAL

HI-STORM FSAR
REPORT HI-2002444

Rev. 3

5.6-1

HI-STORM 100 FSAR, NON-PROPRIETARY
REVISION 12
MARCH 12, 2014.

- [5.2.8] O. W. Hermann, et al., "Validation of the Scale System for PWR Spent Fuel Isotopic Composition Analyses," ORNL/TM-12667, Oak Ridge National Laboratory, March 1995.
- [5.2.9] M. D. DeHart and O. W. Hermann, "An Extension of the Validation of SCALE (SAS2H) Isotopic Predictions for PWR Spent Fuel," ORNL/TM-13317, Oak Ridge National Laboratory, September 1996.
- [5.2.10] O. W. Hermann and M. D. DeHart, "Validation of SCALE (SAS2H) Isotopic Predictions for BWR Spent Fuel," ORNL/TM-13315, Oak Ridge National Laboratory, September 1998.
- [5.2.11] "Summary Report of SNF Isotopic Comparisons for the Disposal Criticality Analysis Methodology," B00000000-01717-5705-00077 REV 00, CRWMS M&O, September 1997.
- [5.2.12] "Isotopic and Criticality Validation of PWR Actinide-Only Burnup Credit," DOE/RW-0497, U.S. Department of Energy, May 1997.
- [5.2.13] B. D. Murphy, "Prediction of the Isotopic Composition of UO₂ Fuel from a BWR: Analysis of the DUI Sample from the Dodewaard Reactor," ORNL/TM-13687, Oak Ridge National Laboratory, October 1998.
- [5.2.14] O. W. Hermann, et al., "Technical Support for a Proposed Decay Heat Guide Using SAS2H/ORIGEN-S Data," NUREG/CR-5625, ORNL-6698, Oak Ridge National Laboratory, September 1994.
- [5.2.15] C. E. Sanders, I. C. Gauld, "Isotopic Analysis of High-Burnup PWR Spent Fuel Samples from the Takahama-3 Reactor," NUREG/CR-6798, ORNL/TM-2001/259, Oak Ridge National Laboratory, January 2003.
- [5.2.16] T. Williams and C. Kelley, "gnuplot An Interactive Plotting Program", Version 3.7, December 1998.
- [5.4.1] "American National Standard Neutron and Gamma-Ray Flux-to-Dose Rate Factors", ANSI/ANS-6.1.1-1977.
- [5.4.2] D. J. Whalen, et al., "MCNP: Photon Benchmark Problems," LA-12196, Los Alamos National Laboratory, September 1991.
- [5.4.3] D. J. Whalen, et al., "MCNP: Neutron Benchmark Problems," LA-12212, Los Alamos National Laboratory, November 1991.

HOLTEC INTERNATIONAL COPYRIGHTED MATERIAL

HI-STORM FSAR
REPORT HI-2002444

Rev. 3

5.6-2

- [5.4.4] J. C. Wagner, et al., "MCNP: Criticality Safety Benchmark Problems," LA-12415, Los Alamos National Laboratory, October 1992.
- [5.4.5] S. E. Turner, "Uncertainty Analysis - Axial Burnup Distribution Effects," presented in "Proceedings of a Workshop on the Use of Burnup Credit in Spent Fuel Transport Casks," SAND-89-0018, Sandia National Laboratory, Oct. 1989.
- [5.4.6] Commonwealth Edison Company, Letter No. NFS-BND-95-083, Chicago, Illinois.

HOLTEC INTERNATIONAL COPYRIGHTED MATERIAL

HI-STORM FSAR
REPORT HI-2002444

Rev. 3

5.6-3

HI-STORM 100 FSAR, NON-PROPRIETARY
REVISION 12
MARCH 12, 2014

APPENDIX 5.A

SAMPLE INPUT FILE FOR SAS2H

HOLTEC INTERNATIONAL COPYRIGHTED MATERIAL

HI-STORM FSAR
REPORT HI-2002444

Appendix 5.A-1

Rev. 0

```

=SAS2H      PARM='halt05,skipshipdata'
bw 15x15 PWR assembly
' fuel temp 923
44groupndf5      LATTICECELL
UO2 1 0.95 923 92234 0.03204 92235 3.6 92236 0.01656
      92238 96.3514 END
,
' Zirc 4 composition
ARBM-ZIRC4 6.55 4 1 0 0 50000 1.7 26000 0.24 24000 0.13 40000 97.93
      2 1.0 595 END
,
' water with 652.5 ppm boron
H2O      3 DEN=0.7135 1 579 END
ARBM-BORMOD 0.7135 1 1 0 0 5000 100 3 652.5E-6 579 END
,
co-59 3 0 1-20 579 end
kr-83 1 0 1-20 923 end
kr-84 1 0 1-20 923 end
kr-85 1 0 1-20 923 end
kr-86 1 0 1-20 923 end
sr-90 1 0 1-20 923 end
y-89 1 0 1-20 923 end
zr-94 1 0 1-20 923 end
zr-95 1 0 1-20 923 end
mo-94 1 0 1-20 923 end
mo-95 1 0 1-20 923 end
nb-94 1 0 1-20 923 end
nb-95 1 0 1-20 923 end
tc-99 1 0 1-20 923 end
ru-106 1 0 1-20 923 end
rh-103 1 0 1-20 923 end
rh-105 1 0 1-20 923 end
sb-124 1 0 1-20 923 end
sn-126 1 0 1-20 923 end
xe-131 1 0 1-20 923 end
xe-132 1 0 1-20 923 end
xe-134 1 0 1-20 923 end
,
xe-135 1 0 1-09 923 end
,
xe-136 1 0 1-20 923 end
cs-133 1 0 1-20 923 end
cs-134 1 0 1-20 923 end
cs-135 1 0 1-20 923 end
cs-137 1 0 1-20 923 end
ba-136 1 0 1-20 923 end
la-139 1 0 1-20 923 end
ce-144 1 0 1-20 923 end
pr-143 1 0 1-20 923 end
nd-143 1 0 1-20 923 end
nd-144 1 0 1-20 923 end
nd-145 1 0 1-20 923 end
nd-146 1 0 1-20 923 end
nd-147 1 0 1-20 923 end
nd-148 1 0 1-20 923 end
nd-150 1 0 1-20 923 end
pm-147 1 0 1-20 923 end
pm-148 1 0 1-20 923 end

```

HOLTEC INTERNATIONAL COPYRIGHTED MATERIAL

HI-STORM FSAR
REPORT HI-2002444

Appendix 5.A-2

Rev. 0

pm-149 1 0 1-20 923 end
sm-147 1 0 1-20 923 end
sm-148 1 0 1-20 923 end
sm-149 1 0 1-20 923 end
sm-150 1 0 1-20 923 end
sm-151 1 0 1-20 923 end
sm-152 1 0 1-20 923 end
eu-151 1 0 1-20 923 end
eu-153 1 0 1-20 923 end
eu-154 1 0 1-20 923 end
eu-155 1 0 1-20 923 end
gd-154 1 0 1-20 923 end
gd-155 1 0 1-20 923 end
gd-157 1 0 1-20 923 end
gd-158 1 0 1-20 923 end
gd-160 1 0 1-20 923 end

END COMP

FUEL-PIN-CELL GEOMETRY:

SQUAREPITCH 1.44272 0.950468 1 3 1.08712 2 0.97028 0 END

MTU in this model is 0.495485 based on fuel dimensions provided

1 power cycle will be used and a library will be generated every
2500 MWD/MTU power level is 40 MW/MTU
therefore 62.5 days per 2500 MWD/MTU
Below
BURN=62.5*NLIB/CYC
POWER=MTU*40

Number of libraries is 20 which is 50,000 MWD/MTU burnup (20*2500)

ASSEMBLY AND CYCLE PARAMETERS:

NPIN/ASSM=208 FUELNGTH=365.76 NCYCLES=1 NLIB/CYC=20
PRINTLEVEL=1
LIGHTEL=5 INPLEVEL=1 NUMHOLES=17
NUMINStr= 0 ORTUBE= 0.6731 SRTUBE=0.63246 END
POWER=19.81938 BURN=1250.0 END

O 66.54421
FE 0.24240868
ZR 98.78151 CR 0.1311304 SN 1.714782

END

=SAS2H PARM='restarts, halt10, skipshipdata'
bw 15x15 PWR assembly

END

=SAS2H PARM='restarts, halt15, skipshipdata'
bw 15x15 PWR assembly

END

=SAS2H PARM='restarts, halt20, skipshipdata'

HOLTEC INTERNATIONAL COPYRIGHTED MATERIAL

HI-STORM FSAR
REPORT HI-2002444

Appendix 5.A-3

Rev. 0

bw 15x15 PWR assembly
END

HOLTEC INTERNATIONAL COPYRIGHTED MATERIAL

HI-STORM FSAR
REPORT HI-2002444

Appendix 5.A-4

Rev. 0

APPENDIX 5.B

SAMPLE INPUT FILE FOR ORIGEN-S

HOLTEC INTERNATIONAL COPYRIGHTED MATERIAL

HI-STORM FSAR
REPORT HI-2002444

Appendix 5.B-1

Rev. 0


```

#ORIGENS
O$$ A4 33 A8 26 A11 71 E
1$$ 1 T
bw 15x15 FUEL -- FT33F001 -
,
' SUBCASE 1 LIBRARY POSITION 1
,
' lib pos grms photon group
3$$ 33 A3 1 0 A16 2 E T
35$$ 0 T
56$$ 5 5 A6 3 A10 0 A13 9 A15 3 A19 1 E
57** 0.0 A3 1.E-5 0.05556 E T
FUEL 3.6
BW 15x15 0.495485 MTU
58** 19.81938 19.81938 19.81938 19.81938 19.81938
60** 1.0000 3.0000 15.0000 30.0000 62.5
66$$ A1 2 A5 2 A9 2 E
73$$ 922350 922340 922360 922380 80000 500000
260000 240000 400000
74** 17837.45 158.7533 82.05225 477406.4 66544.21 1714.782
242.0868 131.1304 98781.51
75$$ 2 2 2 2 4 4 4 4 4 T
,
' SUBCASE 2 LIBRARY POSITION 2
,
3$$ 33 A3 2 0 A16 2 A33 0 E T
35$$ 0 T
56$$ 3 3 A6 3 A10 5 A15 3 A19 1 E
57** 0.0 A3 1.E-5 0.05556 E T
fuel
BW 15X15
58** 19.81938 19.81938 19.81938
60** 18.5 37.0 62.5
66$$ A1 2 A5 2 A9 2 E T
,
' SUBCASE 3 LIBRARY POSITION 3
,
3$$ 33 A3 3 0 A16 2 A33 0 E T
35$$ 0 T
56$$ 3 3 A6 3 A10 3 A15 3 A19 1 E
57** 0.0 A3 1.E-5 0.05556 E T
fuel
BW 15X15
58** 19.81938 19.81938 19.81938
60** 18.5 37.0 62.5
66$$ A1 2 A5 2 A9 2 E T
,
' SUBCASE 4 LIBRARY POSITION 4
,
3$$ 33 A3 4 0 A16 2 A33 0 E T
35$$ 0 T
56$$ 3 3 A6 3 A10 3 A15 3 A19 1 E
57** 0.0 A3 1.E-5 0.05556 E T
fuel
BW 15X15
58** 19.81938 19.81938 19.81938
60** 18.5 37.0 62.5
66$$ A1 2 A5 2 A9 2 E T

```

HOLTEC INTERNATIONAL COPYRIGHTED MATERIAL

HI-STORM FSAR
REPORT HI-2002444

Appendix 5.B-2

Rev. 0

'
' SUBCASE 5 LIBRARY POSITION 5
'
3\$\$ 33 A3 5 0 A16 2 A33 0 E T
35\$\$ 0 T
56\$\$ 3 3 A6 3 A10 3 A15 3 A19 1 E
57** 0.0 A3 1.E-5 0.05556 E T
fuel
BW 15X15
58** 19.81938 19.81938 19.81938
60** 18.5 37.0 62.5
66\$\$ A1 2 A5 2 A9 2 E T

' SUBCASE 6 LIBRARY POSITION 6
'
3\$\$ 33 A3 6 0 A16 2 A33 0 E T
35\$\$ 0 T
56\$\$ 3 3 A6 3 A10 3 A15 3 A19 1 E
57** 0.0 A3 1.E-5 0.05556 E T
fuel
BW 15X15
58** 19.81938 19.81938 19.81938
60** 18.5 37.0 62.5
66\$\$ A1 2 A5 2 A9 2 E T

' SUBCASE 7 LIBRARY POSITION 7
'
3\$\$ 33 A3 7 0 A16 2 A33 0 E T
35\$\$ 0 T
56\$\$ 3 3 A6 3 A10 3 A15 3 A19 1 E
57** 0.0 A3 1.E-5 0.05556 E T
fuel
BW 15X15
58** 19.81938 19.81938 19.81938
60** 18.5 37.0 62.5
66\$\$ A1 2 A5 2 A9 2 E T

' SUBCASE 8 LIBRARY POSITION 8
'
3\$\$ 33 A3 8 0 A16 2 A33 0 E T
35\$\$ 0 T
56\$\$ 3 3 A6 3 A10 3 A15 3 A19 1 E
57** 0.0 A3 1.E-5 0.05556 E T
fuel
BW 15X15
58** 19.81938 19.81938 19.81938
60** 18.5 37.0 62.5
66\$\$ A1 2 A5 2 A9 2 E T

' SUBCASE 9 LIBRARY POSITION 9
'
3\$\$ 33 A3 9 0 A16 2 A33 0 E T
35\$\$ 0 T
56\$\$ 3 3 A6 3 A10 3 A15 3 A19 1 E
57** 0.0 A3 1.E-5 0.05556 E T
fuel
BW 15X15
58** 19.81938 19.81938 19.81938

HOLTEC INTERNATIONAL COPYRIGHTED MATERIAL

HI-STORM FSAR
REPORT HI-2002444

Appendix 5.B-3

Rev. 0

```

60** 18.5 37.0 62.5
66$$ A1 2 A5 2 A9 2 E T
,
' SUBCASE 10 LIBRARY POSITION 10
,
3$$ 33 A3 10 0 A16 2 A33 0 E T
35$$ 0 T
56$$ 3 3 A6 3 A10 3 A15 3 A19 1 E
57** 0.0 A3 1.E-5 0.05556 E T
fuel
BW 15X15
58** 19.81938 19.81938 19.81938
60** 18.5 37.0 62.5
66$$ A1 2 A5 2 A9 2 E T
,
' SUBCASE 11 LIBRARY POSITION 11
,
3$$ 33 A3 11 0 A16 2 A33 0 E T
35$$ 0 T
56$$ 3 3 A6 3 A10 3 A15 3 A19 1 E
57** 0.0 A3 1.E-5 0.05556 E T
fuel
BW 15X15
58** 19.81938 19.81938 19.81938
60** 18.5 37.0 62.5
66$$ A1 2 A5 2 A9 2 E T
,
' SUBCASE 12 LIBRARY POSITION 12
,
3$$ 33 A3 12 0 A16 2 A33 0 E T
35$$ 0 T
56$$ 3 3 A6 3 A10 3 A15 3 A19 1 E
57** 0.0 A3 1.E-5 0.05556 E T
fuel
BW 15X15
58** 19.81938 19.81938 19.81938
60** 18.5 37.0 62.5
66$$ A1 2 A5 2 A9 2 E T
,
' SUBCASE 13 LIBRARY POSITION 13
,
3$$ 33 A3 13 0 A16 2 A33 0 E T
35$$ 0 T
56$$ 3 3 A6 3 A10 3 A15 3 A19 1 E
57** 0.0 A3 1.E-5 0.05556 E T
fuel
BW 15X15
58** 19.81938 19.81938 19.81938
60** 18.5 37.0 62.5
66$$ A1 2 A5 2 A9 2 E T
,
' SUBCASE 14 LIBRARY POSITION 14
,
3$$ 33 A3 14 0 A16 2 A33 0 E T
35$$ 0 T
56$$ 3 3 A6 3 A10 3 A15 3 A19 1 E
57** 0.0 A3 1.E-5 0.05556 E T
fuel

```

HOLTEC INTERNATIONAL COPYRIGHTED MATERIAL

HI-STORM FSAR
REPORT HI-2002444

Appendix 5.B-4

Rev. 0

```

BW 15X15
58** 19.81938 19.81938 19.81938
60** 18.5 37.0 62.5
66$$ A1 2 A5 2 A9 2 E T
'
' SUBCASE 15 LIBRARY POSITION 15
'
3$$ 33 A3 15 0 A16 2 A33 0 E T
35$$ 0 T
56$$ 3 3 A6 3 A10 3 A15 3 A19 1 E
57** 0.0 A3 1.E-5 0.05556 E T
fuel
BW 15X15
58** 19.81938 19.81938 19.81938
60** 18.5 37.0 62.5
66$$ A1 2 A5 2 A9 2 E T
'
' SUBCASE 16 LIBRARY POSITION 16
'
3$$ 33 A3 16 0 A16 2 A33 0 E T
35$$ 0 T
56$$ 3 3 A6 3 A10 3 A15 3 A19 1 E
57** 0.0 A3 1.E-5 0.05556 E T
fuel
BW 15X15
58** 19.81938 19.81938 19.81938
60** 18.5 37.0 62.5
66$$ A1 2 A5 2 A9 2 E T
'
' SUBCASE 17 LIBRARY POSITION 17
'
3$$ 33 A3 17 0 A16 2 A33 0 E T
35$$ 0 T
56$$ 3 3 A6 3 A10 3 A15 3 A19 1 E
57** 0.0 A3 1.E-5 0.05556 E T
fuel
BW 15X15
58** 19.81938 19.81938 19.81938
60** 18.5 37.0 62.5
66$$ A1 2 A5 2 A9 2 E T
'
' SUBCASE 18 LIBRARY POSITION 18
'
3$$ 33 A3 18 A4 7 0 A16 2 A33 18 E T
35$$ 0 T
56$$ 3 3 A6 1 A10 3 A15 3 A19 1 E
57** 0.0 A3 1.E-5 0.05556 E T
fuel
BW 15X15
58** 19.81938 19.81938 19.81938
60** 18.5 37.0 62.5
66$$ A1 2 A5 2 A9 2 E T
'
' SUBCASE - decay
'
54$$ A8 1 E
56$$ 0 9 A6 1 A10 3 A14 3 A15 1 A19 1 E
57** 0.0 0 1.E-5 E T

```

HOLTEC INTERNATIONAL COPYRIGHTED MATERIAL

HI-STORM FSAR
REPORT HI-2002444

Appendix 5.B-5

Rev. 0

fuel enrichment above
 60** 0.5 0.75 1.0 4.0 8.0 12.0 24.0 48.0 96.0
 61** F0.1

65\$\$

'GRAM-ATOMS	GRAMS	CURIES	WATTS-ALL	WATTS-GAMMA		
3Z	0 1 0	0 0 0	1 0 0	3Z	6Z	
3Z	0 1 0	0 0 0	1 0 0	3Z	6Z	
3Z	0 1 0	0 0 0	1 0 0	3Z	6Z	T

' SUBCASE - decay

54\$\$ A8 1 E
 56\$\$ 0 9 A6 1 A10 9 A14 4 A15 1 A19 1 E
 57** 4.0 0 1.E-5 E T
 fuel enrichment above
 60** 10.0 20.0 30.0 60.0 90.0 120.0 180.0 240.0 365.0
 61** F0.1

65\$\$

'GRAM-ATOMS	GRAMS	CURIES	WATTS-ALL	WATTS-GAMMA		
3Z	0 1 0	0 0 0	1 0 0	3Z	6Z	
3Z	0 1 0	0 0 0	1 0 0	3Z	6Z	
3Z	0 1 0	0 0 0	1 0 0	3Z	6Z	T

' SUBCASE - decay

54\$\$ A8 0 E
 56\$\$ 0 9 A6 1 A10 9 A14 5 A15 1 A19 1 E
 57** 1.0 0 1.E-5 E T
 fuel enrichment above
 60** 1.5 3.0 4.0 5.0 6.0 7.0 8.0 9.0 10.0
 61** F1.0e-5

65\$\$

'GRAM-ATOMS	GRAMS	CURIES	WATTS-ALL	WATTS-GAMMA		
3Z	0 1 0	1 0 0	1 0 0	3Z	6Z	
3Z	0 1 0	1 0 0	1 0 0	3Z	6Z	
3Z	0 1 0	1 0 0	1 0 0	3Z	6Z	

81\$\$ 2 0 26 1 E
 82\$\$ 0 2 2 2 2 2 2 2
 83** 1.1E+7 8.0E+6 6.0E+6 4.0E+6 3.0E+6 2.5E+6 2.0E+6 1.5E+6
 1.0E+6 7.0E+5 4.5E+5 3.0E+5 1.5E+5 1.0E+5 7.0E+4 4.5E+4
 3.0E+4 2.0E+4 1.0E+4
 84** 20.0E+6 6.43E+6 3.0E+6 1.85E+6 1.40E+6 9.00E+5 4.00E+5 1.0E+5 T

' SUBCASE - decay

54\$\$ A8 0 E
 56\$\$ 0 10 A6 1 A10 9 A14 5 A15 1 A19 1 E
 57** 10.0 0 1.E-5 E T
 fuel enrichment above
 60** 11.0 12.0 13.0 14.0 15.0 16.0 17.0 18.0 19.0 20.0
 61** F1.0e-5

HOLTEC INTERNATIONAL COPYRIGHTED MATERIAL

HI-STORM FSAR
 REPORT HI-2002444

Appendix 5.B-6

Rev. 0

APPENDIX 5.C

SAMPLE INPUT FILE FOR MCNP

HOLTEC INTERNATIONAL COPYRIGHTED MATERIAL

HI-STORM FSAR
REPORT HI-2002444

Appendix 5.C-1

Rev. 0

message: outp=hs24c1lo srctp=hs24c1ls runtpe=hs24c1lr
mctal=hs24c1lm wssa=hs24c1lw rssa=pt001w

hs24c11

c
c origin is 6 inches below mpc
c
c only cells that contain material are split axially
c importance splitting is not done in cells with 0 material
c
c axial segmentation is at the following boundaries
c 615, 620, 420, 430, 445, 455, 675, 651, 652 ,653
c 654, 655, 656, 657, 680
c

c universe 1

c
301 0 (-40:41:-42:43) -400 u=1
302 0 37 -38 -12 400 -410 u=1
303 0 37 -38 15 400 -410 u=1
304 0 35 -36 -20 400 -410 u=1
305 0 35 -36 23 400 -410 u=1
306 0 37 -38 -12 435 -460 u=1
307 0 37 -38 15 435 -460 u=1
308 0 35 -36 -20 435 -460 u=1
309 0 35 -36 23 435 -460 u=1
310 0 37 -38 -10 410 -435 u=1
311 0 37 -38 17 410 -435 u=1
312 0 35 -36 -18 410 -435 u=1
313 0 35 -36 25 410 -435 u=1
314 5 -7.92 10 -11 26 -27 410 -420 u=-1 \$ left
315 6 -2.644 11 -12 26 -27 410 -420 u=-1 \$ left
316 6 -2.644 15 -16 26 -27 410 -420 u=-1 \$ right
317 5 -7.92 16 -17 26 -27 410 -420 u=-1 \$ right
318 5 -7.92 28 -29 18 -19 410 -420 u=-1 \$ bot
319 6 -2.644 28 -29 19 -20 410 -420 u=-1 \$ bot
320 6 -2.644 28 -29 23 -24 410 -420 u=-1 \$ top
321 5 -7.92 28 -29 24 -25 410 -420 u=-1 \$ top
322 5 -7.92 10 -11 26 -27 420 -430 u=-1 \$ left
323 6 -2.644 11 -12 26 -27 420 -430 u=-1 \$ left
324 6 -2.644 15 -16 26 -27 420 -430 u=-1 \$ right
325 5 -7.92 16 -17 26 -27 420 -430 u=-1 \$ right
326 5 -7.92 28 -29 18 -19 420 -430 u=-1 \$ bot
327 6 -2.644 28 -29 19 -20 420 -430 u=-1 \$ bot
328 6 -2.644 28 -29 23 -24 420 -430 u=-1 \$ top
329 5 -7.92 28 -29 24 -25 420 -430 u=-1 \$ top
330 5 -7.92 10 -11 26 -27 430 -435 u=-1 \$ left
331 6 -2.644 11 -12 26 -27 430 -435 u=-1 \$ left
332 6 -2.644 15 -16 26 -27 430 -435 u=-1 \$ right
333 5 -7.92 16 -17 26 -27 430 -435 u=-1 \$ right
334 5 -7.92 28 -29 18 -19 430 -435 u=-1 \$ bot
335 6 -2.644 28 -29 19 -20 430 -435 u=-1 \$ bot
336 6 -2.644 28 -29 23 -24 430 -435 u=-1 \$ top
337 5 -7.92 28 -29 24 -25 430 -435 u=-1 \$ top
338 0 10 -12 27 -38 410 -435 u=-1 \$ left
339 0 10 -12 37 -26 410 -435 u=-1 \$ left
340 0 15 -17 27 -38 410 -435 u=-1 \$ right
341 0 15 -17 37 -26 410 -435 u=-1 \$ right
342 0 35 -28 18 -20 410 -435 u=-1 \$ bot
343 0 29 -36 18 -20 410 -435 u=-1 \$ bot
344 0 35 -28 23 -25 410 -435 u=-1 \$ top
345 0 29 -36 23 -25 410 -435 u=-1 \$ top
346 5 -7.92 12 -15 20 -23 (-13:-21:22:14) 400 -420 u=-1
347 5 -7.92 12 -15 20 -23 (-13:-21:22:14) 420 -430 u=-1
348 5 -7.92 12 -15 20 -23 (-13:-21:22:14) 430 -445 u=-1
349 5 -7.92 12 -15 20 -23 (-13:-21:22:14) 445 -460 u=-1

HOLTEC INTERNATIONAL COPYRIGHTED MATERIAL

HI-STORM FSAR
REPORT HI-2002444

Appendix 5.C-2

Rev. 0


```

350 0 13 -14 21 -22 (-40:41:-42:43) 400 -455 u=-1
351 9 -1.17e-3 460 u=1
c fuel element
352 0 40 -41 42 -43 -415 u=1
353 5 -1.0783 40 -41 42 -43 415 -420 u=-1 $ lower nozzle
354 0 40 -41 42 -43 420 -425 u=-1 $ space
355 2 -3.8699 40 -41 42 -43 425 -430 u=-1 $ active fuel
356 5 -0.1591 40 -41 42 -43 430 -440 u=-1 $ space
357 5 -0.1591 40 -41 42 -43 440 -445 u=-1 $ plenum spacer
358 5 -1.5410 40 -41 42 -43 445 -455 u=-1 $ top nozzle
359 0 13 -14 21 -22 455 -460 u=-1
c
360 5 -7.92 38 -23 -12 400 -420 u=1
361 5 -7.92 20 -37 -12 400 -420 u=1
362 5 -7.92 12 -35 23 400 -420 u=1
363 5 -7.92 12 -35 -20 400 -420 u=1
364 5 -7.92 36 -15 23 400 -420 u=1
365 5 -7.92 36 -15 -20 400 -420 u=1
366 5 -7.92 38 -23 15 400 -420 u=1
367 5 -7.92 20 -37 15 400 -420 u=1
368 5 -7.92 38 -23 -12 420 -430 u=1
369 5 -7.92 20 -37 -12 420 -430 u=1
370 5 -7.92 12 -35 23 420 -430 u=1
371 5 -7.92 12 -35 -20 420 -430 u=1
372 5 -7.92 36 -15 23 420 -430 u=1
373 5 -7.92 36 -15 -20 420 -430 u=1
374 5 -7.92 38 -23 15 420 -430 u=1
375 5 -7.92 20 -37 15 420 -430 u=1
376 5 -7.92 38 -23 -12 430 -445 u=1
377 5 -7.92 20 -37 -12 430 -445 u=1
378 5 -7.92 12 -35 23 430 -445 u=1
379 5 -7.92 12 -35 -20 430 -445 u=1
380 5 -7.92 36 -15 23 430 -445 u=1
381 5 -7.92 36 -15 -20 430 -445 u=1
382 5 -7.92 38 -23 15 430 -445 u=1
383 5 -7.92 20 -37 15 430 -445 u=1
384 5 -7.92 38 -23 -12 445 -460 u=1
385 5 -7.92 20 -37 -12 445 -460 u=1
386 5 -7.92 12 -35 23 445 -460 u=1
387 5 -7.92 12 -35 -20 445 -460 u=1
388 5 -7.92 36 -15 23 445 -460 u=1
389 5 -7.92 36 -15 -20 445 -460 u=1
390 5 -7.92 38 -23 15 445 -460 u=1
391 5 -7.92 20 -37 15 445 -460 u=1
392 0 23 -12 400 -460 u=1
393 0 23 15 400 -460 u=1
394 0 15 -20 400 -460 u=1
395 0 -12 -20 400 -460 u=1
c
c universe 2
c
401 0 (-40:41:-42:43) -400 u=2
402 0 37 -38 -12 400 -410 u=2
403 0 37 -38 15 400 -410 u=2
404 0 35 -36 -20 400 -410 u=2
405 0 35 -36 23 400 -410 u=2
406 0 37 -38 -12 435 -460 u=2
407 0 37 -38 15 435 -460 u=2
408 0 35 -36 -20 435 -460 u=2
409 0 35 -36 23 435 -460 u=2
410 0 37 -38 -10 410 -435 u=2
411 0 37 -38 17 410 -435 u=2
412 0 35 -36 -18 410 -435 u=2
413 0 35 -36 25 410 -435 u=2
414 5 -7.92 10 -11 26 -27 410 -420 u=-2 $ left

```

HOLTEC INTERNATIONAL COPYRIGHTED MATERIAL

HI-STORM FSAR
REPORT HI-2002444

Appendix 5.C-3

Rev. 0

415	6	-2.644	11	-12	26	-27	410	-420	u=-2	\$ left
416	6	-2.644	15	-16	30	-31	410	-420	u=-2	\$ right
417	5	-7.92	16	-17	30	-31	410	-420	u=-2	\$ right
418	5	-7.92	28	-29	18	-19	410	-420	u=-2	\$ bot
419	6	-2.644	28	-29	19	-20	410	-420	u=-2	\$ bot
420	6	-2.644	32	-33	23	-24	410	-420	u=-2	\$ top
421	5	-7.92	32	-33	24	-25	410	-420	u=-2	\$ top
422	5	-7.92	10	-11	26	-27	420	-430	u=-2	\$ left
423	6	-2.644	11	-12	26	-27	420	-430	u=-2	\$ left
424	6	-2.644	15	-16	30	-31	420	-430	u=-2	\$ right
425	5	-7.92	16	-17	30	-31	420	-430	u=-2	\$ right
426	5	-7.92	28	-29	18	-19	420	-430	u=-2	\$ bot
427	6	-2.644	28	-29	19	-20	420	-430	u=-2	\$ bot
428	6	-2.644	32	-33	23	-24	420	-430	u=-2	\$ top
429	5	-7.92	32	-33	24	-25	420	-430	u=-2	\$ top
430	5	-7.92	10	-11	26	-27	430	-435	u=-2	\$ left
431	6	-2.644	11	-12	26	-27	430	-435	u=-2	\$ left
432	6	-2.644	15	-16	30	-31	430	-435	u=-2	\$ right
433	5	-7.92	16	-17	30	-31	430	-435	u=-2	\$ right
434	5	-7.92	28	-29	18	-19	430	-435	u=-2	\$ bot
435	6	-2.644	28	-29	19	-20	430	-435	u=-2	\$ bot
436	6	-2.644	32	-33	23	-24	430	-435	u=-2	\$ top
437	5	-7.92	32	-33	24	-25	430	-435	u=-2	\$ top
438	0		10	-12	27	-38	410	-435	u=-2	\$ left
439	0		10	-12	37	-26	410	-435	u=-2	\$ left
440	0		15	-17	31	-38	410	-435	u=-2	\$ right
441	0		15	-17	37	-30	410	-435	u=-2	\$ right
442	0		35	-28	18	-20	410	-435	u=-2	\$ bot
443	0		29	-36	18	-20	410	-435	u=-2	\$ bot
444	0		35	-32	23	-25	410	-435	u=-2	\$ top
445	0		33	-36	23	-25	410	-435	u=-2	\$ top
446	5	-7.92	12	-15	20	-23	(-13:-21:22:14)	400	-420	u=-2
447	5	-7.92	12	-15	20	-23	(-13:-21:22:14)	420	-430	u=-2
448	5	-7.92	12	-15	20	-23	(-13:-21:22:14)	430	-445	u=-2
449	5	-7.92	12	-15	20	-23	(-13:-21:22:14)	445	-460	u=-2
450	0		13	-14	21	-22	(-40:41:-42:43)	400	-455	u=-2
451	9	-1.17e-3					460		u=2	
c		fuel element								
452	0		40	-41	42	-43		-415	u=2	
453	5	-1.0783	40	-41	42	-43	415	-420	u=-2	\$ lower nozzle
454	0		40	-41	42	-43	420	-425	u=-2	\$ space
455	2	-3.8699	40	-41	42	-43	425	-430	u=-2	\$ active fuel
456	5	-0.1591	40	-41	42	-43	430	-440	u=-2	\$ space
457	5	-0.1591	40	-41	42	-43	440	-445	u=-2	\$ plenum spacer
458	5	-1.5410	40	-41	42	-43	445	-455	u=-2	\$ top nozzle
459	0		13	-14	21	-22	455	-460	u=-2	
c										
460	5	-7.92	38	-23	-12		400	-420	u=2	
461	5	-7.92	20	-37	-12		400	-420	u=2	
462	0		12	-35	23		400	-420	u=2	
463	5	-7.92	12	-35	-20		400	-420	u=2	
464	0		36	-15	23		400	-420	u=2	
465	5	-7.92	36	-15	-20		400	-420	u=2	
466	0		38	-23	15		400	-420	u=2	
467	0		20	-37	15		400	-420	u=2	
468	5	-7.92	38	-23	-12		420	-430	u=2	
469	5	-7.92	20	-37	-12		420	-430	u=2	
470	0		12	-35	23		420	-430	u=2	
471	5	-7.92	12	-35	-20		420	-430	u=2	
472	0		36	-15	23		420	-430	u=2	
473	5	-7.92	36	-15	-20		420	-430	u=2	
474	0		38	-23	15		420	-430	u=2	
475	0		20	-37	15		420	-430	u=2	
476	5	-7.92	38	-23	-12		430	-445	u=2	
477	5	-7.92	20	-37	-12		430	-445	u=2	

HOLTEC INTERNATIONAL COPYRIGHTED MATERIAL

HI-STORM FSAR
REPORT HI-2002444

Appendix 5.C-4

Rev. 0

478	0		12 -35 23	430 -445	u=2	
479	5 -7.92		12 -35 -20	430 -445	u=2	
480	0		36 -15 23	430 -445	u=2	
481	5 -7.92		36 -15 -20	430 -445	u=2	
482	0		38 -23 15	430 -445	u=2	
483	0		20 -37 15	430 -445	u=2	
484	5 -7.92		38 -23 -12	445 -460	u=2	
485	5 -7.92		20 -37 -12	445 -460	u=2	
486	0		12 -35 23	445 -460	u=2	
487	5 -7.92		12 -35 -20	445 -460	u=2	
488	0		36 -15 23	445 -460	u=2	
489	5 -7.92		36 -15 -20	445 -460	u=2	
490	0		38 -23 15	445 -460	u=2	
491	0		20 -37 15	445 -460	u=2	
492	0		23 -12	400 -460	u=2	
493	0		23 15	400 -460	u=2	
494	0		15 -20	400 -460	u=2	
495	0		-12 -20	400 -460	u=2	
c						
c	universe 3					
c						
501	0		(-40:41:-42:43)	-400	u=3	
502	0	37 -38	-12	400 -410	u=3	
503	0	37 -38	15	400 -410	u=3	
504	0	35 -36		-20 400 -410	u=3	
505	0	35 -36		23 400 -410	u=3	
506	0	37 -38	-12	435 -460	u=3	
507	0	37 -38	15	435 -460	u=3	
508	0	35 -36		-20 435 -460	u=3	
509	0	35 -36		23 435 -460	u=3	
510	0	37 -38	-10	410 -435	u=3	
511	0	37 -38	17	410 -435	u=3	
512	0	35 -36		-18 410 -435	u=3	
513	0	35 -36		25 410 -435	u=3	
514	5 -7.92		10 -11 30 -31	410 -420	u=-3 \$ left	
515	6 -2.644		11 -12 30 -31	410 -420	u=-3 \$ left	
516	6 -2.644		15 -16 26 -27	410 -420	u=-3 \$ right	
517	5 -7.92		16 -17 26 -27	410 -420	u=-3 \$ right	
518	5 -7.92		28 -29 18 -19	410 -420	u=-3 \$ bot	
519	6 -2.644		28 -29 19 -20	410 -420	u=-3 \$ bot	
520	6 -2.644		32 -33 23 -24	410 -420	u=-3 \$ top	
521	5 -7.92		32 -33 24 -25	410 -420	u=-3 \$ top	
522	5 -7.92		10 -11 30 -31	420 -430	u=-3 \$ left	
523	6 -2.644		11 -12 30 -31	420 -430	u=-3 \$ left	
524	6 -2.644		15 -16 26 -27	420 -430	u=-3 \$ right	
525	5 -7.92		16 -17 26 -27	420 -430	u=-3 \$ right	
526	5 -7.92		28 -29 18 -19	420 -430	u=-3 \$ bot	
527	6 -2.644		28 -29 19 -20	420 -430	u=-3 \$ bot	
528	6 -2.644		32 -33 23 -24	420 -430	u=-3 \$ top	
529	5 -7.92		32 -33 24 -25	420 -430	u=-3 \$ top	
530	5 -7.92		10 -11 30 -31	430 -435	u=-3 \$ left	
531	6 -2.644		11 -12 30 -31	430 -435	u=-3 \$ left	
532	6 -2.644		15 -16 26 -27	430 -435	u=-3 \$ right	
533	5 -7.92		16 -17 26 -27	430 -435	u=-3 \$ right	
534	5 -7.92		28 -29 18 -19	430 -435	u=-3 \$ bot	
535	6 -2.644		28 -29 19 -20	430 -435	u=-3 \$ bot	
536	6 -2.644		32 -33 23 -24	430 -435	u=-3 \$ top	
537	5 -7.92		32 -33 24 -25	430 -435	u=-3 \$ top	
538	0		10 -12 31 -38	410 -435	u=-3 \$ left	
539	0		10 -12 37 -30	410 -435	u=-3 \$ left	
540	0		15 -17 27 -38	410 -435	u=-3 \$ right	
541	0		15 -17 37 -26	410 -435	u=-3 \$ right	
542	0		35 -28 18 -20	410 -435	u=-3 \$ bot	
543	0		29 -36 18 -20	410 -435	u=-3 \$ bot	
544	0		35 -32 23 -25	410 -435	u=-3 \$ top	

HOLTEC INTERNATIONAL COPYRIGHTED MATERIAL

HI-STORM FSAR
REPORT HI-2002444

Appendix 5.C-5

Rev. 0

```

545 0 33 -36 23 -25 410 -435 u=-3 $ top
546 5 -7.92 12 -15 20 -23 (-13:-21:22:14) 400 -420 u=-3
547 5 -7.92 12 -15 20 -23 (-13:-21:22:14) 420 -430 u=-3
548 5 -7.92 12 -15 20 -23 (-13:-21:22:14) 430 -445 u=-3
549 5 -7.92 12 -15 20 -23 (-13:-21:22:14) 445 -460 u=-3
550 0 13 -14 21 -22 (-40:41:-42:43) 400 -455 u=-3
551 9 -1.17e-3 460 u=3
c fuel element
552 0 40 -41 42 -43 -415 u=3
553 5 -1.0783 40 -41 42 -43 415 -420 u=-3 $ lower nozzle
554 0 40 -41 42 -43 420 -425 u=-3 $ space
555 2 -3.8699 40 -41 42 -43 425 -430 u=-3 $ active fuel
556 5 -0.1591 40 -41 42 -43 430 -440 u=-3 $ space
557 5 -0.1591 40 -41 42 -43 440 -445 u=-3 $ plenum spacer
558 5 -1.5410 40 -41 42 -43 445 -455 u=-3 $ top nozzle
559 0 13 -14 21 -22 455 -460 u=-3
c
560 0 38 -23 -12 400 -420 u=3
561 0 20 -37 -12 400 -420 u=3
562 0 12 -35 23 400 -420 u=3
563 5 -7.92 12 -35 -20 400 -420 u=3
564 0 36 -15 23 400 -420 u=3
565 5 -7.92 36 -15 -20 400 -420 u=3
566 5 -7.92 38 -23 15 400 -420 u=3
567 5 -7.92 20 -37 15 400 -420 u=3
568 5 -7.92 38 -23 -12 420 -430 u=3
569 5 -7.92 20 -37 -12 420 -430 u=3
570 0 12 -35 23 420 -430 u=3
571 0 12 -35 -20 420 -430 u=3
572 5 -7.92 36 -15 23 420 -430 u=3
573 0 36 -15 -20 420 -430 u=3
574 5 -7.92 38 -23 15 420 -430 u=3
575 5 -7.92 20 -37 15 420 -430 u=3
576 5 -7.92 38 -23 -12 430 -445 u=3
577 5 -7.92 20 -37 -12 430 -445 u=3
578 0 12 -35 23 430 -445 u=3
579 0 12 -35 -20 430 -445 u=3
580 5 -7.92 36 -15 23 430 -445 u=3
581 0 36 -15 -20 430 -445 u=3
582 5 -7.92 38 -23 15 430 -445 u=3
583 5 -7.92 20 -37 15 430 -445 u=3
584 5 -7.92 38 -23 -12 445 -460 u=3
585 5 -7.92 20 -37 -12 445 -460 u=3
586 0 12 -35 23 445 -460 u=3
587 0 12 -35 -20 445 -460 u=3
588 5 -7.92 36 -15 23 445 -460 u=3
589 0 36 -15 -20 445 -460 u=3
590 5 -7.92 38 -23 15 445 -460 u=3
591 5 -7.92 20 -37 15 445 -460 u=3
592 0 23 -12 400 -460 u=3
593 0 23 15 400 -460 u=3
594 0 15 -20 400 -460 u=3
595 0 -12 -20 400 -460 u=3
c
c universe 4
c
601 0 (-40:41:-42:43) -400 u=4
602 0 37 -38 -12 400 -410 u=4
603 0 37 -38 15 400 -410 u=4
604 0 35 -36 -20 400 -410 u=4
605 0 35 -36 23 400 -410 u=4
606 0 37 -38 -12 435 -460 u=4
607 0 37 -38 15 435 -460 u=4
608 0 35 -36 -20 435 -460 u=4
609 0 35 -36 23 435 -460 u=4

```

HOLTEC INTERNATIONAL COPYRIGHTED MATERIAL

HI-STORM FSAR
REPORT HI-2002444

Appendix 5.C-6

Rev. 0

610	0	37 -38	-10		410 -435 u=4	
611	0	37 -38	17		410 -435 u=4	
612	0	35 -36		-18	410 -435 u=4	
613	0	35 -36		25	410 -435 u=4	
614	5	-7.92	10 -11 30	-31 410	-420 u=-4 \$ left	
615	6	-2.644	11 -12 30	-31 410	-420 u=-4 \$ left	
616	6	-2.644	15 -16 26	-27 410	-420 u=-4 \$ right	
617	5	-7.92	16 -17 26	-27 410	-420 u=-4 \$ right	
618	5	-7.92	32 -33 18	-19 410	-420 u=-4 \$ bot	
619	6	-2.644	32 -33 19	-20 410	-420 u=-4 \$ bot	
620	6	-2.644	28 -29 23	-24 410	-420 u=-4 \$ top	
621	5	-7.92	28 -29 24	-25 410	-420 u=-4 \$ top	
622	5	-7.92	10 -11 30	-31 420	-430 u=-4 \$ left	
623	6	-2.644	11 -12 30	-31 420	-430 u=-4 \$ left	
624	6	-2.644	15 -16 26	-27 420	-430 u=-4 \$ right	
625	5	-7.92	16 -17 26	-27 420	-430 u=-4 \$ right	
626	5	-7.92	32 -33 18	-19 420	-430 u=-4 \$ bot	
627	6	-2.644	32 -33 19	-20 420	-430 u=-4 \$ bot	
628	6	-2.644	28 -29 23	-24 420	-430 u=-4 \$ top	
629	5	-7.92	28 -29 24	-25 420	-430 u=-4 \$ top	
630	5	-7.92	10 -11 30	-31 430	-435 u=-4 \$ left	
631	6	-2.644	11 -12 30	-31 430	-435 u=-4 \$ left	
632	6	-2.644	15 -16 26	-27 430	-435 u=-4 \$ right	
633	5	-7.92	16 -17 26	-27 430	-435 u=-4 \$ right	
634	5	-7.92	32 -33 18	-19 430	-435 u=-4 \$ bot	
635	6	-2.644	32 -33 19	-20 430	-435 u=-4 \$ bot	
636	6	-2.644	28 -29 23	-24 430	-435 u=-4 \$ top	
637	5	-7.92	28 -29 24	-25 430	-435 u=-4 \$ top	
638	0		10 -12 31	-38 410	-435 u=-4 \$ left	
639	0		10 -12 37	-30 410	-435 u=-4 \$ left	
640	0		15 -17 27	-38 410	-435 u=-4 \$ right	
641	0		15 -17 37	-26 410	-435 u=-4 \$ right	
642	0		35 -32 18	-20 410	-435 u=-4 \$ bot	
643	0		33 -36 18	-20 410	-435 u=-4 \$ bot	
644	0		35 -28 23	-25 410	-435 u=-4 \$ top	
645	0		29 -36 23	-25 410	-435 u=-4 \$ top	
646	5	-7.92	12 -15 20	-23 (-13:-21:22:14)	400 -420 u=-4	
647	5	-7.92	12 -15 20	-23 (-13:-21:22:14)	420 -430 u=-4	
648	5	-7.92	12 -15 20	-23 (-13:-21:22:14)	430 -445 u=-4	
649	5	-7.92	12 -15 20	-23 (-13:-21:22:14)	445 -460 u=-4	
650	0		13 -14 21	-22 (-40:41:-42:43)	400 -455 u=-4	
651	9	-1.17e-3			460 u=4	
c		fuel element				
652	0		40 -41 42	-43 -415	u=4	
653	5	-1.0783	40 -41 42	-43 415	-420 u=-4 \$ lower nozzle	
654	0		40 -41 42	-43 420	-425 u=-4 \$ space	
655	2	-3.8699	40 -41 42	-43 425	-430 u=-4 \$ active fuel	
656	5	-0.1591	40 -41 42	-43 430	-440 u=-4 \$ space	
657	5	-0.1591	40 -41 42	-43 440	-445 u=-4 \$ plenum spacer	
658	5	-1.5410	40 -41 42	-43 445	-455 u=-4 \$ top nozzle	
659	0		13 -14 21	-22 455	-460 u=-4	
c						
660	0		38 -23	-12 400	-420 u=4	
661	0		20 -37	-12 400	-420 u=4	
662	5	-7.92	12 -35	23 400	-420 u=4	
663	0		12 -35	-20 400	-420 u=4	
664	5	-7.92	36 -15	23 400	-420 u=4	
665	0		36 -15	-20 400	-420 u=4	
666	5	-7.92	38 -23	15 400	-420 u=4	
667	5	-7.92	20 -37	15 400	-420 u=4	
668	0		38 -23	-12 420	-430 u=4	
669	0		20 -37	-12 420	-430 u=4	
670	5	-7.92	12 -35	23 420	-430 u=4	
671	0		12 -35	-20 420	-430 u=4	
672	5	-7.92	36 -15	23 420	-430 u=4	

HOLTEC INTERNATIONAL COPYRIGHTED MATERIAL

HI-STORM FSAR
REPORT HI-2002444

Appendix 5.C-7

Rev: 0

673	0		36	-15	-20	420	-430	u=4
674	5	-7.92	38	-23	15	420	-430	u=4
675	5	-7.92	20	-37	15	420	-430	u=4
676	0		38	-23	-12	430	-445	u=4
677	0		20	-37	-12	430	-445	u=4
678	5	-7.92	12	-35	23	430	-445	u=4
679	0		12	-35	-20	430	-445	u=4
680	5	-7.92	36	-15	23	430	-445	u=4
681	0		36	-15	-20	430	-445	u=4
682	5	-7.92	38	-23	15	430	-445	u=4
683	5	-7.92	20	-37	15	430	-445	u=4
684	0		38	-23	-12	445	-460	u=4
685	0		20	-37	-12	445	-460	u=4
686	5	-7.92	12	-35	23	445	-460	u=4
687	0		12	-35	-20	445	-460	u=4
688	5	-7.92	36	-15	23	445	-460	u=4
689	0		36	-15	-20	445	-460	u=4
690	5	-7.92	38	-23	15	445	-460	u=4
691	5	-7.92	20	-37	15	445	-460	u=4
692	0		23	-12		400	-460	u=4
693	0		23	15		400	-460	u=4
694	0		15	-20		400	-460	u=4
695	0		-12	-20		400	-460	u=4
c								
c								
c								
c								
701	0							
702	0	37	-38					
703	0	37	-38	15				
704	0	35	-36					
705	0	35	-36		23			
706	0	37	-38		-12			
707	0	37	-38	15				
708	0	35	-36		-20			
709	0	35	-36		23			
710	0	37	-38		-10			
711	0	37	-38	17				
712	0	35	-36		-18			
713	0	35	-36		25			
714	5	-7.92		10	-11	26	-27	410 -420 u=-5 \$ left
715	6	-2.644		11	-12	26	-27	410 -420 u=-5 \$ left
716	6	-2.644		15	-16	30	-31	410 -420 u=-5 \$ right
717	5	-7.92		16	-17	30	-31	410 -420 u=-5 \$ right
718	5	-7.92		32	-33	18	-19	410 -420 u=-5 \$ bot
719	6	-2.644		32	-33	19	-20	410 -420 u=-5 \$ bot
720	6	-2.644		28	-29	23	-24	410 -420 u=-5 \$ top
721	5	-7.92		28	-29	24	-25	410 -420 u=-5 \$ top
722	5	-7.92		10	-11	26	-27	420 -430 u=-5 \$ left
723	6	-2.644		11	-12	26	-27	420 -430 u=-5 \$ left
724	6	-2.644		15	-16	30	-31	420 -430 u=-5 \$ right
725	5	-7.92		16	-17	30	-31	420 -430 u=-5 \$ right
726	5	-7.92		32	-33	18	-19	420 -430 u=-5 \$ bot
727	6	-2.644		32	-33	19	-20	420 -430 u=-5 \$ bot
728	6	-2.644		28	-29	23	-24	420 -430 u=-5 \$ top
729	5	-7.92		28	-29	24	-25	420 -430 u=-5 \$ top
730	5	-7.92		10	-11	26	-27	430 -435 u=-5 \$ left
731	6	-2.644		11	-12	26	-27	430 -435 u=-5 \$ left
732	6	-2.644		15	-16	30	-31	430 -435 u=-5 \$ right
733	5	-7.92		16	-17	30	-31	430 -435 u=-5 \$ right
734	5	-7.92		32	-33	18	-19	430 -435 u=-5 \$ bot
735	6	-2.644		32	-33	19	-20	430 -435 u=-5 \$ bot
736	6	-2.644		28	-29	23	-24	430 -435 u=-5 \$ top
737	5	-7.92		28	-29	24	-25	430 -435 u=-5 \$ top
738	0			10	-12	27	-38	410 -435 u=-5 \$ left
739	0			10	-12	37	-26	410 -435 u=-5 \$ left

HOLTEC INTERNATIONAL COPYRIGHTED MATERIAL

HI-STORM FSAR
REPORT HI-2002444

Appendix 5.C-8

Rev. 0

```

740 0 15 -17 31 -38 410 -435 u=-5 $ right
741 0 15 -17 37 -30 410 -435 u=-5 $ right
742 0 35 -32 18 -20 410 -435 u=-5 $ bot
743 0 33 -36 18 -20 410 -435 u=-5 $ bot
744 0 35 -28 23 -25 410 -435 u=-5 $ top
745 0 29 -36 23 -25 410 -435 u=-5 $ top
746 5 -7.92 12 -15 20 -23 (-13:-21:22:14) 400 -420 u=-5
747 5 -7.92 12 -15 20 -23 (-13:-21:22:14) 420 -430 u=-5
748 5 -7.92 12 -15 20 -23 (-13:-21:22:14) 430 -445 u=-5
749 5 -7.92 12 -15 20 -23 (-13:-21:22:14) 445 -460 u=-5
750 0 13 -14 21 -22 (-40:41:-42:43) 400 -455 u=-5
751 9 -1.17e-3 460 u=5
c fuel element
752 0 40 -41 42 -43 -415 u=5
753 5 -1.0783 40 -41 42 -43 415 -420 u=-5 $ lower nozzle
754 0 40 -41 42 -43 420 -425 u=-5 $ space
755 2 -3.8699 40 -41 42 -43 425 -430 u=-5 $ active fuel
756 5 -0.1591 40 -41 42 -43 430 -440 u=-5 $ space
757 5 -0.1591 40 -41 42 -43 440 -445 u=-5 $ plenum spacer
758 5 -1.5410 40 -41 42 -43 445 -455 u=-5 $ top nozzle
759 0 13 -14 21 -22 455 -460 u=-5
c
760 5 -7.92 38 -23 -12 400 -420 u=5
761 5 -7.92 20 -37 -12 400 -420 u=5
762 5 -7.92 12 -35 23 400 -420 u=5
763 0 12 -35 -20 400 -420 u=5
764 5 -7.92 36 -15 23 400 -420 u=5
765 0 36 -15 -20 400 -420 u=5
766 0 38 -23 15 400 -420 u=5
767 0 20 -37 15 400 -420 u=5
768 5 -7.92 38 -23 -12 420 -430 u=5
769 5 -7.92 20 -37 -12 420 -430 u=5
770 5 -7.92 12 -35 23 420 -430 u=5
771 0 12 -35 -20 420 -430 u=5
772 5 -7.92 36 -15 23 420 -430 u=5
773 0 36 -15 -20 420 -430 u=5
774 0 38 -23 15 420 -430 u=5
775 0 20 -37 15 420 -430 u=5
776 5 -7.92 38 -23 -12 430 -445 u=5
777 5 -7.92 20 -37 -12 430 -445 u=5
778 5 -7.92 12 -35 23 430 -445 u=5
779 0 12 -35 -20 430 -445 u=5
780 5 -7.92 36 -15 23 430 -445 u=5
781 0 36 -15 -20 430 -445 u=5
782 0 38 -23 15 430 -445 u=5
783 0 20 -37 15 430 -445 u=5
784 5 -7.92 38 -23 -12 445 -460 u=5
785 5 -7.92 20 -37 -12 445 -460 u=5
786 5 -7.92 12 -35 23 445 -460 u=5
787 0 12 -35 -20 445 -460 u=5
788 5 -7.92 36 -15 23 445 -460 u=5
789 0 36 -15 -20 445 -460 u=5
790 0 38 -23 15 445 -460 u=5
791 0 20 -37 15 445 -460 u=5
792 0 23 -12 400 -460 u=5
793 0 23 15 400 -460 u=5
794 0 15 -20 400 -460 u=5
795 0 -12 -20 400 -460 u=5
c
c egg crate
c
c storage locations
c
c 201 0 -301 -112 101 620 -675
202 0 -301 112 -113 101 620 -675

```

HOLTEC INTERNATIONAL COPYRIGHTED MATERIAL

HI-STORM FSAR
REPORT HI-2002444

Appendix 5.C-9

Rev. 0

```

203 0 -301 113 -114 101      620 -675
c   204 0 -301 114      101      620 -675
c
205 0 -301      -111 102      620 -675
206 0 -301 111 -112 102 -101 620 -675
101 0 -301 112 -113 102 -101 620 -675
fill=3 (-13.68679 68.43395 0.0)
102 0 -301 113 -114 102 -101 620 -675
fill=2 ( 13.68679 68.43395 0.0)
207 0 -301 114 -115 102 -101 620 -675
208 0 -301 115      102      620 -675
c
c   209 0 -301      -110 103      620 -675
210 0 -301 110 -111 103 -102 620 -675
103 0      111 -112 103 -102 620 -675
fill=3 (-41.06037 41.06037 0.0)
104 0      112 -113 103 -102 620 -675
fill=1 (-13.68679 41.06037 0.0)
105 0      113 -114 103 -102 620 -675
fill=1 ( 13.68679 41.06037 0.0)
106 0      114 -115 103 -102 620 -675
fill=2 ( 41.06037 41.06037 0.0)
211 0 -301 115 -116 103 -102 620 -675
c   212 0 -301 116      103      620 -675
c
c   213 0 -301      -110 104 -103 620 -675
107 0 -301 110 -111 104 -103 620 -675
fill=3 (-68.43395 13.68679 0.0)
108 0      111 -112 104 -103 620 -675
fill=1 (-41.06037 13.68679 0.0)
109 0      112 -113 104 -103 620 -675
fill=1 (-13.68679 13.68679 0.0)
110 0      113 -114 104 -103 620 -675
fill=1 ( 13.68679 13.68679 0.0)
111 0      114 -115 104 -103 620 -675
fill=1 ( 41.06037 13.68679 0.0)
112 0 -301 115 -116 104 -103 620 -675
fill=2 ( 68.43395 13.68679 0.0)
214 0 -301 116      104 -103 620 -675
c
c   215 0 -301      -110 105 -104 620 -675
113 0 -301 110 -111 105 -104 620 -675
fill=4 (-68.43395 -13.68679 0.0)
114 0      111 -112 105 -104 620 -675
fill=1 (-41.06037 -13.68679 0.0)
115 0      112 -113 105 -104 620 -675
fill=1 (-13.68679 -13.68679 0.0)
116 0      113 -114 105 -104 620 -675
fill=1 ( 13.68679 -13.68679 0.0)
117 0      114 -115 105 -104 620 -675
fill=1 ( 41.06037 -13.68679 0.0)
118 0 -301 115 -116 105 -104 620 -675
fill=5 ( 68.43395 -13.68679 0.0)
216 0 -301 116      105 -104 620 -675
c
c   217 0 -301      -110      -105 620 -675
218 0 -301 110 -111 106 -105 620 -675
119 0      111 -112 106 -105 620 -675
fill=4 (-41.06037 -41.06037 0.0)
120 0      112 -113 106 -105 620 -675
fill=1 (-13.68679 -41.06037 0.0)
121 0      113 -114 106 -105 620 -675
fill=1 ( 13.68679 -41.06037 0.0)
122 0      114 -115 106 -105 620 -675
fill=5 ( 41.06037 -41.06037 0.0)

```

HOLTEC INTERNATIONAL COPYRIGHTED MATERIAL

HI-STORM FSAR
REPORT HI-2002444

Appendix 5.C-10

Rev. 0


```

219 0 -301 115 -116 106 -105 620 -675
c 220 0 -301 116 -105 620 -675
c
221 0 -301 -111 -106 620 -675
222 0 -301 111 -112 107 -106 620 -675
123 0 -301 112 -113 107 -106 620 -675
fill=4 (-13.68679 -68.43395 0.0)
124 0 -301 113 -114 107 -106 620 -675
fill=5 ( 13.68679 -68.43395 0.0)
223 0 -301 114 -115 107 -106 620 -675
224 0 -301 115 -106 620 -675
c
c 225 0 -301 -112 -107 620 -675
226 0 -301 112 -113 -107 620 -675
227 0 -301 113 -114 -107 620 -675
c 228 0 -301 114 -107 620 -675
c
1001 5 -7.92 301 -302 610 -615 $ MPC shell
1003 5 -7.92 301 -302 615 -616 $ MPC shell
1005 5 -7.92 301 -302 616 -620 $ MPC shell
1007 5 -7.92 301 -302 620 -420 $ MPC shell
1009 5 -7.92 301 -302 420 -430 $ MPC shell
1011 5 -7.92 301 -302 430 -445 $ MPC shell
1013 5 -7.92 301 -302 445 -460 $ MPC shell
1014 5 -7.92 301 -302 460 -675 $ MPC shell
1015 5 -7.92 301 -302 675 -651 $ MPC shell
1017 5 -7.92 301 -302 651 -652 $ MPC shell
1019 5 -7.92 301 -302 652 -653 $ MPC shell
1021 5 -7.92 301 -302 653 -654 $ MPC shell
1023 5 -7.92 301 -302 654 -655 $ MPC shell
1025 5 -7.92 301 -302 655 -656 $ MPC shell
1027 5 -7.92 301 -302 656 -657 $ MPC shell
1028 5 -7.92 301 -302 657 -658 $ MPC shell
1029 5 -7.92 301 -302 658 -659 $ MPC shell
1031 5 -7.92 301 -302 659 -680 $ MPC shell
c
1051 5 -7.92 -301 610 -615 $ MPC baseplate
1052 5 -7.92 -301 615 -616 $ MPC baseplate
1053 5 -7.92 -301 616 -620 $ MPC baseplate
1060 5 -7.92 -301 675 -651 $ MPC lid
1061 5 -7.92 -301 651 -652 $ MPC lid
1062 5 -7.92 -301 652 -653 $ MPC lid
1063 5 -7.92 -301 653 -654 $ MPC lid
1064 5 -7.92 -301 654 -655 $ MPC lid
1065 5 -7.92 -301 655 -656 $ MPC lid
1066 5 -7.92 -301 656 -657 $ MPC lid
1067 5 -7.92 -301 657 -658 $ MPC lid
1068 5 -7.92 -301 658 -659 $ MPC lid
1069 5 -7.92 -301 659 -680 $ MPC lid
c
c overpack universes
c
c pedestal
c
2001 8 -7.82 -302 801 -610
2002 8 -7.82 -302 802 -801
2003 8 -7.82 -302 803 -802
2004 8 -7.82 -302 804 -803
2005 8 -7.82 -302 805 -804
c
2006 7 -2.35 -306 806 -805
2007 7 -2.35 -306 807 -806
2008 7 -2.35 -306 808 -807
2009 7 -2.35 -306 809 -808
2010 7 -2.35 -306 810 -809

```

HOLTEC INTERNATIONAL COPYRIGHTED MATERIAL

HI-STORM FSAR
REPORT HI-2002444

Appendix 5.C-11

Rev. 0

2011	7	-2.35		-306	811	-810
2012	7	-2.35		-306	812	-811
2013	7	-2.35		-306	813	-812
2014	7	-2.35		-306	814	-813
c						
2016	8	-7.82	306	-302	806	-805
2017	8	-7.82	306	-302	807	-806
2028	8	-7.82	306	-302	808	-807
2019	8	-7.82	306	-302	809	-808
2020	8	-7.82	306	-302	810	-809
2021	8	-7.82	306	-302	811	-810
2022	8	-7.82	306	-302	812	-811
2023	8	-7.82	306	-302	813	-812
2024	8	-7.82	306	-302	814	-813
c						
				overpack	baseplate	
2031	8	-7.82		-302	815	-814
2032	8	-7.82		-302	816	-815
2033	7	-2.35		-302	817	-816
c						
				gap between overpack and lid		
3001	9	-1.17e-3		-302	680	-901
c						
c				lid		
c						
3002	8	-7.82		-307	901	-902
3003	8	-7.82		-307	902	-903
c						
3004	7	-2.35		-305	903	-904
3005	7	-2.35		-305	904	-905
3006	7	-2.35		-305	905	-906
3007	7	-2.35		-305	906	-907
3008	7	-2.35		-305	907	-908
3009	7	-2.35		-305	908	-909
c						
3010	8	-7.82	305	-307	903	-904
3011	8	-7.82	305	-307	904	-905
3012	8	-7.82	305	-307	905	-906
3013	8	-7.82	305	-307	906	-907
3014	8	-7.82	305	-307	907	-908
3015	8	-7.82	305	-307	908	-909
c						
3021	8	-7.82		-307	909	-910
3022	8	-7.82		-307	910	-911
3023	8	-7.82		-307	911	-912
3024	8	-7.82		-307	912	-913
c						
3030	0			-303	913	-914
3031	0			-303	914	-915
3032	0			-303	915	-916
3033	0			-303	916	-917
3034	0			-303	917	-918
c						
3035	8	-7.82	303	-304	913	-914
3036	8	-7.82	303	-304	914	-915
3037	8	-7.82	303	-304	915	-916
3038	8	-7.82	303	-304	916	-917
3039	0		303	-304	917	-918
c						
3040	7	-2.35	304	-307	913	-914
3041	7	-2.35	304	-307	914	-915
3042	7	-2.35	304	-307	915	-916
3043	7	-2.35	304	-307	916	-917
3044	0		304	-307	917	-918
c						
c						
c						
c						
				steel, concrete and air in gap between mpc and overpack		

HOLTEC INTERNATIONAL COPYRIGHTED MATERIAL

HI-STORM FSAR
REPORT HI-2002444

Appendix 5.C-12

Rev. 0

c

4000	7	-2.35	302	-700	817	-816
4001	8	-7.82	302	-700	816	-815
4002	8	-7.82	302	-700	815	-814
4003	9	-1.17e-3	302	-700	814	-813
4004	9	-1.17e-3	302	-700	813	-812
4005	9	-1.17e-3	302	-700	812	-811
4006	9	-1.17e-3	302	-700	811	-810
4007	9	-1.17e-3	302	-700	810	-809
4008	9	-1.17e-3	302	-700	809	-808
4009	9	-1.17e-3	302	-700	808	-807
4010	9	-1.17e-3	302	-700	807	-806
4011	9	-1.17e-3	302	-700	806	-805
4012	9	-1.17e-3	302	-700	805	-804
4013	9	-1.17e-3	302	-700	804	-803
4014	9	-1.17e-3	302	-700	803	-802
4015	9	-1.17e-3	302	-700	802	-801
4016	9	-1.17e-3	302	-700	801	-610
4017	9	-1.17e-3	302	-700	610	-615
4018	9	-1.17e-3	302	-700	615	-620
4019	9	-1.17e-3	302	-700	620	-420
4020	9	-1.17e-3	302	-700	420	-430
4021	9	-1.17e-3	302	-700	430	-445
4022	9	-1.17e-3	302	-700	445	-460
4023	9	-1.17e-3	302	-700	460	-675
4024	9	-1.17e-3	302	-700	675	-651
4025	9	-1.17e-3	302	-700	651	-652
4026	9	-1.17e-3	302	-700	652	-653
4027	9	-1.17e-3	302	-700	653	-654
4028	9	-1.17e-3	302	-700	654	-655
4029	9	-1.17e-3	302	-700	655	-656
4030	9	-1.17e-3	302	-700	656	-657
4031	9	-1.17e-3	302	-700	657	-658
4032	9	-1.17e-3	302	-700	658	-659
4033	9	-1.17e-3	302	-700	659	-680
4034	9	-1.17e-3	302	-700	680	-901
4035	9	-1.17e-3	307	-700	901	-902
4036	9	-1.17e-3	307	-700	902	-903
4037	9	-1.17e-3	307	-700	903	-904
4038	9	-1.17e-3	307	-700	904	-905
4039	9	-1.17e-3	307	-700	905	-906
4040	9	-1.17e-3	307	-700	906	-907
4041	9	-1.17e-3	307	-700	907	-908
4042	9	-1.17e-3	307	-700	908	-909
4043	8	-7.82	307	-700	909	-910
4044	8	-7.82	307	-700	910	-911
4045	8	-7.82	307	-700	911	-912
4046	8	-7.82	307	-700	912	-913
4047	7	-2.35	307	-700	913	-914
4048	7	-2.35	307	-700	914	-915
4049	7	-2.35	307	-700	915	-916
4050	7	-2.35	307	-700	916	-917
4051	0		307	-700	917	-918

c
c importance splitting regions in overpack

5000	7	-2.35	700	-701	817	-816
5001	0		700	-701	816	-815 fill=10
5002	0		700	-701	815	-814 fill=10
5003	0		700	-701	814	-813 fill=11
5004	0		700	-701	813	-812 fill=11
5005	0		700	-701	812	-811 fill=11
5006	0		700	-701	811	-810 fill=11
5007	0		700	-701	810	-809 fill=11
5008	0		700	-701	809	-808 fill=11

HOLTEC INTERNATIONAL COPYRIGHTED MATERIAL

HI-STORM FSAR
REPORT HI-2002444

Appendix 5.C-13

Rev. 0

5009 0 700 -701 808 -807 fill=11
5010 8 -7.82 700 -701 807 -806
5011 8 -7.82 700 -701 806 -805
5012 8 -7.82 700 -701 805 -804
5013 8 -7.82 700 -701 804 -803
5014 8 -7.82 700 -701 803 -802
5015 8 -7.82 700 -701 802 -801
5016 8 -7.82 700 -701 801 -610
5017 8 -7.82 700 -701 610 -615
5018 8 -7.82 700 -701 615 -620
5019 8 -7.82 700 -701 620 -420
5020 8 -7.82 700 -701 420 -430
5021 8 -7.82 700 -701 430 -445
5022 8 -7.82 700 -701 445 -460
5023 8 -7.82 700 -701 460 -675
5024 8 -7.82 700 -701 675 -651
5025 8 -7.82 700 -701 651 -652
5026 8 -7.82 700 -701 652 -653
5027 8 -7.82 700 -701 653 -654
5028 8 -7.82 700 -701 654 -655
5029 8 -7.82 700 -701 655 -656
5030 8 -7.82 700 -701 656 -657
5031 8 -7.82 700 -701 657 -658
5032 8 -7.82 700 -701 658 -659
5033 8 -7.82 700 -701 659 -680
5034 8 -7.82 700 -701 680 -901
5035 8 -7.82 700 -701 901 -902
5036 8 -7.82 700 -701 902 -903
5037 8 -7.82 700 -701 903 -904
5038 0 700 -701 904 -905 fill=13
5039 0 700 -701 905 -906 fill=13
5040 0 700 -701 906 -907 fill=13
5041 0 700 -701 907 -908 fill=13
5042 0 700 -701 908 -909 fill=13
5043 8 -7.82 700 -701 909 -910
5044 8 -7.82 700 -701 910 -911
5045 8 -7.82 700 -701 911 -912
5046 8 -7.82 700 -701 912 -913
5047 7 -2.35 700 -701 913 -914
5048 7 -2.35 700 -701 914 -915
5049 7 -2.35 700 -701 915 -916
5050 7 -2.35 700 -701 916 -917
5051 0 700 -701 917 -918
c
5100 7 -2.35 701 -702 817 -816
5101 0 701 -702 816 -815 fill=10
5102 0 701 -702 815 -814 fill=10
5103 0 701 -702 814 -813 fill=11
5104 0 701 -702 813 -812 fill=11
5105 0 701 -702 812 -811 fill=11
5106 0 701 -702 811 -810 fill=11
5107 0 701 -702 810 -809 fill=11
5108 0 701 -702 809 -808 fill=11
5109 0 701 -702 808 -807 fill=11
5110 8 -7.82 701 -311 807 -806
5111 8 -7.82 701 -311 806 -805
5112 8 -7.82 701 -311 805 -804
5113 8 -7.82 701 -311 804 -803
5114 8 -7.82 701 -311 803 -802
5115 8 -7.82 701 -311 802 -801
5116 8 -7.82 701 -311 801 -610
5117 8 -7.82 701 -311 610 -615
5118 8 -7.82 701 -311 615 -620
5119 8 -7.82 701 -311 620 -420
5120 8 -7.82 701 -311 420 -430

HOLTEC INTERNATIONAL COPYRIGHTED MATERIAL

HI-STORM FSAR
REPORT HI-2002444

Appendix 5.C-14

Rev. 0

5121	8	-7.82	701	-311	430	-445
5122	8	-7.82	701	-311	445	-460
5123	8	-7.82	701	-311	460	-675
5124	8	-7.82	701	-311	675	-651
5125	8	-7.82	701	-311	651	-652
5126	8	-7.82	701	-311	652	-653
5127	8	-7.82	701	-311	653	-654
5128	8	-7.82	701	-311	654	-655
5129	8	-7.82	701	-311	655	-656
5130	8	-7.82	701	-311	656	-657
5131	8	-7.82	701	-311	657	-658
5132	8	-7.82	701	-311	658	-659
5133	8	-7.82	701	-311	659	-680
5134	8	-7.82	701	-311	680	-901
5135	8	-7.82	701	-311	901	-902
5136	8	-7.82	701	-311	902	-903
5137	8	-7.82	701	-311	903	-904
5138	0		701	-702	904	-905 fill=13
5139	0		701	-702	905	-906 fill=13
5140	0		701	-702	906	-907 fill=13
5141	0		701	-702	907	-908 fill=13
5142	0		701	-702	908	-909 fill=13
5143	8	-7.82	701	-702	909	-910
5144	8	-7.82	701	-702	910	-911
5145	8	-7.82	701	-702	911	-912
5146	8	-7.82	701	-702	912	-913
5147	7	-2.35	701	-702	913	-914
5148	7	-2.35	701	-702	914	-915
5149	7	-2.35	701	-702	915	-916
5150	7	-2.35	701	-702	916	-917
5151	0		701	-702	917	-918
c						
5200	7	-2.35	702	-703	817	-816
5201	0		702	-703	816	-815 fill=10
5202	0		702	-703	815	-814 fill=10
5203	0		702	-703	814	-813 fill=11
5204	0		702	-703	813	-812 fill=11
5205	0		702	-703	812	-811 fill=11
5206	0		702	-703	811	-810 fill=11
5207	0		702	-703	810	-809 fill=11
5208	0		702	-703	809	-808 fill=11
5209	0		702	-703	808	-807 fill=11
5210	0		311	-703	807	-806 fill=112
5211	0		311	-703	806	-805 fill=112
5212	0		311	-703	805	-804 fill=112
5213	0		311	-703	804	-803 fill=112
5214	0		311	-703	803	-802 fill=112
5215	0		311	-703	802	-801 fill=112
5216	0		311	-703	801	-610 fill=112
5217	0		311	-703	610	-615 fill=112
5218	0		311	-703	615	-620 fill=112
5219	0		311	-703	620	-420 fill=112
5220	0		311	-703	420	-430 fill=112
5221	0		311	-703	430	-445 fill=112
5222	0		311	-703	445	-460 fill=112
5223	0		311	-703	460	-675 fill=112
5224	0		311	-703	675	-651 fill=112
5225	0		311	-703	651	-652 fill=112
5226	0		311	-703	652	-653 fill=112
5227	0		311	-703	653	-654 fill=112
5228	0		311	-703	654	-655 fill=112
5229	0		311	-703	655	-656 fill=112
5230	0		311	-703	656	-657 fill=112
5231	0		311	-703	657	-658 fill=112
5232	0		311	-703	658	-659 fill=112

HOLTEC INTERNATIONAL COPYRIGHTED MATERIAL

HI-STORM FSAR
REPORT HI-2002444

Appendix 5.C-15

Rev. 0

5233 0 311 -703 659 -680 fill=112
 5234 0 311 -703 680 -901 fill=112
 5235 0 311 -703 901 -902 fill=112
 5236 0 311 -703 902 -903 fill=112
 5237 0 311 -703 903 -904 fill=112
 5238 0 702 -703 904 -905 fill=13
 5239 0 702 -703 905 -906 fill=13
 5240 0 702 -703 906 -907 fill=13
 5241 0 702 -703 907 -908 fill=13
 5242 0 702 -703 908 -909 fill=13
 5243 8 -7.82 702 -703 909 -910
 5244 8 -7.82 702 -703 910 -911
 5245 8 -7.82 702 -703 911 -912
 5246 8 -7.82 702 -703 912 -913
 5247 7 -2.35 702 -703 913 -914
 5248 7 -2.35 702 -703 914 -915
 5249 7 -2.35 702 -703 915 -916
 5250 7 -2.35 702 -703 916 -917
 5251 0 702 -703 917 -918

c

5300 7 -2.35 703 -705 817 -816
 5301 0 703 -705 816 -815 fill=10
 5302 0 703 -705 815 -814 fill=10
 5303 0 703 -705 814 -813 fill=11
 5304 0 703 -705 813 -812 fill=11
 5305 0 703 -705 812 -811 fill=11
 5306 0 703 -705 811 -810 fill=11
 5307 0 703 -705 810 -809 fill=11
 5308 0 703 -705 809 -808 fill=11
 5309 0 703 -705 808 -807 fill=11
 5310 0 703 -705 807 -806 fill=112
 5311 0 703 -705 806 -805 fill=112
 5312 0 703 -705 805 -804 fill=112
 5313 0 703 -705 804 -803 fill=112
 5314 0 703 -705 803 -802 fill=112
 5315 0 703 -705 802 -801 fill=112
 5316 0 703 -705 801 -610 fill=112
 5317 0 703 -705 610 -615 fill=112
 5318 0 703 -705 615 -620 fill=112
 5319 0 703 -705 620 -420 fill=112
 5320 0 703 -705 420 -430 fill=112
 5321 0 703 -705 430 -445 fill=112
 5322 0 703 -705 445 -460 fill=112
 5323 0 703 -705 460 -675 fill=112
 5324 0 703 -705 675 -651 fill=112
 5325 0 703 -705 651 -652 fill=112
 5326 0 703 -705 652 -653 fill=112
 5327 0 703 -705 653 -654 fill=112
 5328 0 703 -705 654 -655 fill=112
 5329 0 703 -705 655 -656 fill=112
 5330 0 703 -705 656 -657 fill=112
 5331 0 703 -705 657 -658 fill=112
 5332 0 703 -705 658 -659 fill=112
 5333 0 703 -705 659 -680 fill=112
 5334 0 703 -705 680 -901 fill=112
 5335 0 703 -705 901 -902 fill=112
 5336 0 703 -705 902 -903 fill=112
 5337 0 703 -705 903 -904 fill=112
 5338 0 703 -705 904 -905 fill=13
 5339 0 703 -705 905 -906 fill=13
 5340 0 703 -705 906 -907 fill=13
 5341 0 703 -705 907 -908 fill=13
 5342 0 703 -705 908 -909 fill=13
 5343 8 -7.82 703 -705 909 -910
 5344 8 -7.82 703 -705 910 -911

HOLTEC INTERNATIONAL COPYRIGHTED MATERIAL

HI-STORM FSAR
 REPORT HI-2002444

Appendix 5.C-16

Rev. 0

5345	8	-7.82	703	-705	911	-912
5346	8	-7.82	703	-705	912	-913
5347	0		703	-705	913	-914 fill=14
5348	0		703	-705	914	-915 fill=14
5349	0		703	-705	915	-916 fill=14
5350	0		703	-705	916	-917 fill=14
5351	0		703	-705	917	-918
c						
c	5401	0	704	-705	816	-815 fill=10
c	5402	0	704	-705	815	-814 fill=10
c	5403	0	704	-705	814	-813 fill=11
c	5404	0	704	-705	813	-812 fill=11
c	5405	0	704	-705	812	-811 fill=11
c	5406	0	704	-705	811	-810 fill=11
c	5407	0	704	-705	810	-809 fill=11
c	5408	0	704	-705	809	-808 fill=11
c	5409	0	704	-705	808	-807 fill=11
c	5410	0	704	-705	807	-806 fill=112
c	5411	0	704	-705	806	-805 fill=112
c	5412	0	704	-705	805	-804 fill=112
c	5413	0	704	-705	804	-803 fill=112
c	5414	0	704	-705	803	-802 fill=112
c	5415	0	704	-705	802	-801 fill=112
c	5416	0	704	-705	801	-610 fill=112
c	5417	0	704	-705	610	-615 fill=112
c	5418	0	704	-705	615	-620 fill=112
c	5419	0	704	-705	620	-420 fill=112
c	5420	0	704	-705	420	-430 fill=112
c	5421	0	704	-705	430	-445 fill=112
c	5422	0	704	-705	445	-460 fill=112
c	5423	0	704	-705	460	-675 fill=112
c	5424	0	704	-705	675	-651 fill=112
c	5425	0	704	-705	651	-652 fill=112
c	5426	0	704	-705	652	-653 fill=112
c	5427	0	704	-705	653	-654 fill=112
c	5428	0	704	-705	654	-655 fill=112
c	5429	0	704	-705	655	-656 fill=112
c	5430	0	704	-705	656	-657 fill=112
c	5431	0	704	-705	657	-658 fill=112
c	5432	0	704	-705	658	-659 fill=112
c	5433	0	704	-705	659	-680 fill=112
c	5434	0	704	-705	680	-901 fill=112
c	5435	0	704	-705	901	-902 fill=112
c	5436	0	704	-705	902	-903 fill=112
c	5437	0	704	-705	903	-904 fill=112
c	5438	0	704	-705	904	-905 fill=13
c	5439	0	704	-705	905	-906 fill=13
c	5440	0	704	-705	906	-907 fill=13
c	5441	0	704	-705	907	-908 fill=13
c	5442	0	704	-705	908	-909 fill=13
c	5443	8	-7.82	704	-705	909 -910
c	5444	8	-7.82	704	-705	910 -911
c	5445	8	-7.82	704	-705	911 -912
c	5446	8	-7.82	704	-705	912 -913
c	5447	0	704	-705	913	-914 fill=14
c	5448	0	704	-705	914	-915 fill=14
c	5449	0	704	-705	915	-916 fill=14
c	5450	0	704	-705	916	-917 fill=14
c	5451	0	704	-705	917	-918
c						
5500	7	-2.35	705	-707	817	-816
5501	0		705	-707	816	-815 fill=10
5502	0		705	-707	815	-814 fill=10
5503	0		705	-707	814	-813 fill=11
5504	0		705	-707	813	-812 fill=11

HOLTEC INTERNATIONAL COPYRIGHTED MATERIAL

HI-STORM FSAR
REPORT HI-2002444

Appendix 5.C-17

Rev. 0

5505	0	705	-707	812	-811	fill=11
5506	0	705	-707	811	-810	fill=11
5507	0	705	-707	810	-809	fill=11
5508	0	705	-707	809	-808	fill=11
5509	0	705	-707	808	-807	fill=11
5510	0	705	-707	807	-806	fill=112
5511	0	705	-707	806	-805	fill=112
5512	0	705	-707	805	-804	fill=112
5513	0	705	-707	804	-803	fill=112
5514	0	705	-707	803	-802	fill=112
5515	0	705	-707	802	-801	fill=112
5516	0	705	-707	801	-610	fill=112
5517	0	705	-707	610	-615	fill=112
5518	0	705	-707	615	-620	fill=112
5519	0	705	-707	620	-420	fill=112
5520	0	705	-707	420	-430	fill=112
5521	0	705	-707	430	-445	fill=112
5522	0	705	-707	445	-460	fill=112
5523	0	705	-707	460	-675	fill=112
5524	0	705	-707	675	-651	fill=112
5525	0	705	-707	651	-652	fill=112
5526	0	705	-707	652	-653	fill=112
5527	0	705	-707	653	-654	fill=112
5528	0	705	-707	654	-655	fill=112
5529	0	705	-707	655	-656	fill=112
5530	0	705	-707	656	-657	fill=112
5531	0	705	-707	657	-658	fill=112
5532	0	705	-707	658	-659	fill=112
5533	0	705	-707	659	-680	fill=112
5534	0	705	-707	680	-901	fill=112
5535	0	705	-707	901	-902	fill=112
5536	0	705	-707	902	-903	fill=112
5537	0	705	-707	903	-904	fill=112
5538	0	705	-707	904	-905	fill=13
5539	0	705	-707	905	-906	fill=13
5540	0	705	-707	906	-907	fill=13
5541	0	705	-707	907	-908	fill=13
5542	0	705	-707	908	-909	fill=13
5543	8	-7.82	705	-707	909	-910
5544	8	-7.82	705	-707	910	-911
5545	8	-7.82	705	-707	911	-912
5546	8	-7.82	705	-707	912	-913
5547	0	705	-716	913	-914	
5548	0	705	-716	914	-915	
5549	0	705	-716	915	-916	
5550	0	705	-716	916	-917	
5551	0	705	-716	917	-918	
c						
c	5601	0	706	-707	816	-815 fill=10
c	5602	0	706	-707	815	-814 fill=10
c	5603	0	706	-707	814	-813 fill=11
c	5604	0	706	-707	813	-812 fill=11
c	5605	0	706	-707	812	-811 fill=11
c	5606	0	706	-707	811	-810 fill=11
c	5607	0	706	-707	810	-809 fill=11
c	5608	0	706	-707	809	-808 fill=11
c	5609	0	706	-707	808	-807 fill=11
c	5610	0	706	-707	807	-806 fill=112
c	5611	0	706	-707	806	-805 fill=112
c	5612	0	706	-707	805	-804 fill=112
c	5613	0	706	-707	804	-803 fill=112
c	5614	0	706	-707	803	-802 fill=112
c	5615	0	706	-707	802	-801 fill=112
c	5616	0	706	-707	801	-610 fill=112
c	5617	0	706	-707	610	-615 fill=112

HOLTEC INTERNATIONAL COPYRIGHTED MATERIAL

HI-STORM FSAR
REPORT HI-2002444

Appendix 5.C-18

Rev. 0

c	5618	0	706	-707	615	-620	fill=112
c	5619	0	706	-707	620	-420	fill=112
c	5620	0	706	-707	420	-430	fill=112
c	5621	0	706	-707	430	-445	fill=112
c	5622	0	706	-707	445	-460	fill=112
c	5623	0	706	-707	460	-675	fill=112
c	5624	0	706	-707	675	-651	fill=112
c	5625	0	706	-707	651	-652	fill=112
c	5626	0	706	-707	652	-653	fill=112
c	5627	0	706	-707	653	-654	fill=112
c	5628	0	706	-707	654	-655	fill=112
c	5629	0	706	-707	655	-656	fill=112
c	5630	0	706	-707	656	-657	fill=112
c	5631	0	706	-707	657	-658	fill=112
c	5632	0	706	-707	658	-659	fill=112
c	5633	0	706	-707	659	-680	fill=112
c	5634	0	706	-707	680	-901	fill=112
c	5635	0	706	-707	901	-902	fill=112
c	5636	0	706	-707	902	-903	fill=112
c	5637	0	706	-707	903	-904	fill=112
c	5638	0	706	-707	904	-905	fill=13
c	5639	0	706	-707	905	-906	fill=13
c	5640	0	706	-707	906	-907	fill=13
c	5641	0	706	-707	907	-908	fill=13
c	5642	0	706	-707	908	-909	fill=13
c	5643	8	-7.82	706	-707	909	-910
c	5644	8	-7.82	706	-707	910	-911
c	5645	8	-7.82	706	-707	911	-912
c	5646	8	-7.82	706	-707	912	-913
c	5647	0	706	-707	913	-914	
c	5648	0	706	-707	914	-915	
c	5649	0	706	-707	915	-916	
c	5650	0	706	-707	916	-917	
c	5651	0	706	-707	917	-918	
c							
5700	7	-2.35	707	-709	817	-816	
5701	0		707	-709	816	-815	fill=10
5702	0		707	-709	815	-814	fill=10
5703	0		707	-709	814	-813	fill=11
5704	0		707	-709	813	-812	fill=11
5705	0		707	-709	812	-811	fill=11
5706	0		707	-709	811	-810	fill=11
5707	0		707	-709	810	-809	fill=11
5708	0		707	-709	809	-808	fill=11
5709	0		707	-709	808	-807	fill=11
5710	0		707	-709	807	-806	fill=112
5711	0		707	-709	806	-805	fill=112
5712	0		707	-709	805	-804	fill=112
5713	0		707	-709	804	-803	fill=112
5714	0		707	-709	803	-802	fill=112
5715	0		707	-709	802	-801	fill=112
5716	0		707	-709	801	-610	fill=112
5717	0		707	-709	610	-615	fill=112
5718	0		707	-709	615	-620	fill=112
5719	0		707	-709	620	-420	fill=112
5720	0		707	-709	420	-430	fill=112
5721	0		707	-709	430	-445	fill=112
5722	0		707	-709	445	-460	fill=112
5723	0		707	-709	460	-675	fill=112
5724	0		707	-709	675	-651	fill=112
5725	0		707	-709	651	-652	fill=112
5726	0		707	-709	652	-653	fill=112
5727	0		707	-709	653	-654	fill=112
5728	0		707	-709	654	-655	fill=112
5729	0		707	-709	655	-656	fill=112

HOLTEC INTERNATIONAL COPYRIGHTED MATERIAL

HI-STORM FSAR
REPORT HI-2002444

Appendix 5.C-19

Rev. 0

5730	0	707	-709	656	-657	fill=112
5731	0	707	-709	657	-658	fill=112
5732	0	707	-709	658	-659	fill=112
5733	0	707	-709	659	-680	fill=112
5734	0	707	-709	680	-901	fill=112
5735	0	707	-709	901	-902	fill=112
5736	0	707	-709	902	-903	fill=112
5737	0	707	-709	903	-904	fill=112
5738	0	707	-709	904	-905	fill=13
5739	0	707	-709	905	-906	fill=13
5740	0	707	-709	906	-907	fill=13
5741	0	707	-709	907	-908	fill=13
5742	0	707	-709	908	-909	fill=13
5743	8	-7.82	707	-709	909	-910
5744	8	-7.82	707	-709	910	-911
5745	8	-7.82	707	-709	911	-912
5746	8	-7.82	707	-709	912	-913
c	5747	0	707	-709	913	-914
c	5748	0	707	-709	914	-915
c	5749	0	707	-709	915	-916
c	5750	0	707	-709	916	-917
c	5751	0	707	-709	917	-918
c						
c	5801	0	708	-709	816	-815 fill=10
c	5802	0	708	-709	815	-814 fill=10
c	5803	0	708	-709	814	-813 fill=11
c	5804	0	708	-709	813	-812 fill=11
c	5805	0	708	-709	812	-811 fill=11
c	5806	0	708	-709	811	-810 fill=11
c	5807	0	708	-709	810	-809 fill=11
c	5808	0	708	-709	809	-808 fill=11
c	5809	0	708	-709	808	-807 fill=11
c	5810	0	708	-709	807	-806 fill=112
c	5811	0	708	-709	806	-805 fill=112
c	5812	0	708	-709	805	-804 fill=112
c	5813	0	708	-709	804	-803 fill=112
c	5814	0	708	-709	803	-802 fill=112
c	5815	0	708	-709	802	-801 fill=112
c	5816	0	708	-709	801	-610 fill=112
c	5817	0	708	-709	610	-615 fill=112
c	5818	0	708	-709	615	-620 fill=112
c	5819	0	708	-709	620	-420 fill=112
c	5820	0	708	-709	420	-430 fill=112
c	5821	0	708	-709	430	-445 fill=112
c	5822	0	708	-709	445	-460 fill=112
c	5823	0	708	-709	460	-675 fill=112
c	5824	0	708	-709	675	-651 fill=112
c	5825	0	708	-709	651	-652 fill=112
c	5826	0	708	-709	652	-653 fill=112
c	5827	0	708	-709	653	-654 fill=112
c	5828	0	708	-709	654	-655 fill=112
c	5829	0	708	-709	655	-656 fill=112
c	5830	0	708	-709	656	-657 fill=112
c	5831	0	708	-709	657	-658 fill=112
c	5832	0	708	-709	658	-659 fill=112
c	5833	0	708	-709	659	-680 fill=112
c	5834	0	708	-709	680	-901 fill=112
c	5835	0	708	-709	901	-902 fill=112
c	5836	0	708	-709	902	-903 fill=112
c	5837	0	708	-709	903	-904 fill=112
c	5838	0	708	-709	904	-905 fill=13
c	5839	0	708	-709	905	-906 fill=13
c	5840	0	708	-709	906	-907 fill=13
c	5841	0	708	-709	907	-908 fill=13
c	5842	0	708	-709	908	-909 fill=13

HOLTEC INTERNATIONAL COPYRIGHTED MATERIAL

HI-STORM FSAR
REPORT HI-2002444

Appendix 5.C-20

Rev. 0

c	5843	8	-7.82	708	-709	909	-910
c	5844	8	-7.82	708	-709	910	-911
c	5845	8	-7.82	708	-709	911	-912
c	5846	8	-7.82	708	-709	912	-913
c	5847	0		708	-709	913	-914
c	5848	0		708	-709	914	-915
c	5849	0		708	-709	915	-916
c	5850	0		708	-709	916	-917
c	5851	0		708	-709	917	-918
c							
5900	7	-2.35		709	-711	817	-816
5901	0			709	-711	816	-815 fill=10
5902	0			709	-711	815	-814 fill=10
5903	0			709	-711	814	-813 fill=11
5904	0			709	-711	813	-812 fill=11
5905	0			709	-711	812	-811 fill=11
5906	0			709	-711	811	-810 fill=11
5907	0			709	-711	810	-809 fill=11
5908	0			709	-711	809	-808 fill=11
5909	0			709	-711	808	-807 fill=11
5910	0			709	-711	807	-806 fill=112
5911	0			709	-711	806	-805 fill=112
5912	0			709	-711	805	-804 fill=112
5913	0			709	-711	804	-803 fill=112
5914	0			709	-711	803	-802 fill=112
5915	0			709	-711	802	-801 fill=112
5916	0			709	-711	801	-610 fill=112
5917	0			709	-711	610	-615 fill=112
5918	0			709	-711	615	-620 fill=112
5919	0			709	-711	620	-420 fill=112
5920	0			709	-711	420	-430 fill=112
5921	0			709	-711	430	-445 fill=112
5922	0			709	-711	445	-460 fill=112
5923	0			709	-711	460	-675 fill=112
5924	0			709	-711	675	-651 fill=112
5925	0			709	-711	651	-652 fill=112
5926	0			709	-711	652	-653 fill=112
5927	0			709	-711	653	-654 fill=112
5928	0			709	-711	654	-655 fill=112
5929	0			709	-711	655	-656 fill=112
5930	0			709	-711	656	-657 fill=112
5931	0			709	-711	657	-658 fill=112
5932	0			709	-711	658	-659 fill=112
5933	0			709	-711	659	-680 fill=112
5934	0			709	-711	680	-901 fill=112
5935	0			709	-711	901	-902 fill=112
5936	0			709	-711	902	-903 fill=112
5937	0			709	-711	903	-904 fill=112
5938	0			709	-711	904	-905 fill=13
5939	0			709	-711	905	-906 fill=13
5940	0			709	-711	906	-907 fill=13
5941	0			709	-711	907	-908 fill=13
5942	0			709	-711	908	-909 fill=13
5943	8	-7.82		709	-711	909	-910
5944	8	-7.82		709	-711	910	-911
5945	8	-7.82		709	-711	911	-912
5946	8	-7.82		709	-711	912	-913
c	5947	0		709	-711	913	-914
c	5948	0		709	-711	914	-915
c	5949	0		709	-711	915	-916
c	5950	0		709	-711	916	-917
c	5951	0		709	-711	917	-918
c							
c	6001	0		710	-711	816	-815 fill=10
c	6002	0		710	-711	815	-814 fill=10

HOLTEC INTERNATIONAL COPYRIGHTED MATERIAL

HI-STORM FSAR
REPORT HI-2002444

Appendix 5.C-21

Rev. 0

c	6003	0	710	-711	814	-813	fill=11
c	6004	0	710	-711	813	-812	fill=11
c	6005	0	710	-711	812	-811	fill=11
c	6006	0	710	-711	811	-810	fill=11
c	6007	0	710	-711	810	-809	fill=11
c	6008	0	710	-711	809	-808	fill=11
c	6009	0	710	-711	808	-807	fill=11
c	6010	0	710	-711	807	-806	fill=112
c	6011	0	710	-711	806	-805	fill=112
c	6012	0	710	-711	805	-804	fill=112
c	6013	0	710	-711	804	-803	fill=112
c	6014	0	710	-711	803	-802	fill=112
c	6015	0	710	-711	802	-801	fill=112
c	6016	0	710	-711	801	-610	fill=112
c	6017	0	710	-711	610	-615	fill=112
c	6018	0	710	-711	615	-620	fill=112
c	6019	0	710	-711	620	-420	fill=112
c	6020	0	710	-711	420	-430	fill=112
c	6021	0	710	-711	430	-445	fill=112
c	6022	0	710	-711	445	-460	fill=112
c	6023	0	710	-711	460	-675	fill=112
c	6024	0	710	-711	675	-651	fill=112
c	6025	0	710	-711	651	-652	fill=112
c	6026	0	710	-711	652	-653	fill=112
c	6027	0	710	-711	653	-654	fill=112
c	6028	0	710	-711	654	-655	fill=112
c	6029	0	710	-711	655	-656	fill=112
c	6030	0	710	-711	656	-657	fill=112
c	6031	0	710	-711	657	-658	fill=112
c	6032	0	710	-711	658	-659	fill=112
c	6033	0	710	-711	659	-680	fill=112
c	6034	0	710	-711	680	-901	fill=112
c	6035	0	710	-711	901	-902	fill=112
c	6036	0	710	-711	902	-903	fill=112
c	6037	0	710	-711	903	-904	fill=112
c	6038	0	710	-711	904	-905	fill=13
c	6039	0	710	-711	905	-906	fill=13
c	6040	0	710	-711	906	-907	fill=13
c	6041	0	710	-711	907	-908	fill=13
c	6042	0	710	-711	908	-909	fill=13
c	6043	8	-7.82	710	-711	909	-910
c	6044	8	-7.82	710	-711	910	-911
c	6045	8	-7.82	710	-711	911	-912
c	6046	8	-7.82	710	-711	912	-913
c	6047	0	710	-711	913	-914	
c	6048	0	710	-711	914	-915	
c	6049	0	710	-711	915	-916	
c	6050	0	710	-711	916	-917	
c	6051	0	710	-711	917	-918	
c	6100	7	-2.35	711	-713	817	-816
c	6101	0	711	-713	816	-815	fill=10
c	6102	0	711	-713	815	-814	fill=10
c	6103	0	711	-713	814	-813	fill=11
c	6104	0	711	-713	813	-812	fill=11
c	6105	0	711	-713	812	-811	fill=11
c	6106	0	711	-713	811	-810	fill=11
c	6107	0	711	-713	810	-809	fill=11
c	6108	0	711	-713	809	-808	fill=11
c	6109	0	711	-713	808	-807	fill=11
c	6110	0	711	-713	807	-806	fill=112
c	6111	0	711	-713	806	-805	fill=112
c	6112	0	711	-713	805	-804	fill=112
c	6113	0	711	-713	804	-803	fill=112
c	6114	0	711	-713	803	-802	fill=112

HOLTEC INTERNATIONAL COPYRIGHTED MATERIAL

HI-STORM FSAR
REPORT HI-2002444

Appendix 5.C-22

Rev. 0

6115	0	711	-713	802	-801	fill=112	
6116	0	711	-713	801	-610	fill=112	
6117	0	711	-713	610	-615	fill=112	
6118	0	711	-713	615	-620	fill=112	
6119	0	711	-713	620	-420	fill=112	
6120	0	711	-713	420	-430	fill=112	
6121	0	711	-713	430	-445	fill=112	
6122	0	711	-713	445	-460	fill=112	
6123	0	711	-713	460	-675	fill=112	
6124	0	711	-713	675	-651	fill=112	
6125	0	711	-713	651	-652	fill=112	
6126	0	711	-713	652	-653	fill=112	
6127	0	711	-713	653	-654	fill=112	
6128	0	711	-713	654	-655	fill=112	
6129	0	711	-713	655	-656	fill=112	
6130	0	711	-713	656	-657	fill=112	
6131	0	711	-713	657	-658	fill=112	
6132	0	711	-713	658	-659	fill=112	
6133	0	711	-713	659	-680	fill=112	
6134	0	711	-713	680	-901	fill=112	
6135	0	711	-713	901	-902	fill=112	
6136	0	711	-713	902	-903	fill=112	
6137	0	711	-713	903	-904	fill=112	
6138	0	711	-713	904	-905	fill=113	
6139	0	711	-713	905	-906	fill=113	
6140	0	711	-713	906	-907	fill=113	
6141	0	711	-713	907	-908	fill=113	
6142	0	711	-713	908	-909	fill=113	
6143	8	-7.82	711	-713	909	-910	
6144	8	-7.82	711	-713	910	-911	
6145	8	-7.82	711	-713	911	-912	
6146	8	-7.82	711	-713	912	-913	
c	6147	0	711	-713	913	-914	
c	6148	0	711	-713	914	-915	
c	6149	0	711	-713	915	-916	
c	6150	0	711	-713	916	-917	
c	6151	0	711	-713	917	-918	
c							
c	6201	0	712	-713	816	-815	fill=10
c	6202	0	712	-713	815	-814	fill=10
c	6203	0	712	-713	814	-813	fill=11
c	6204	0	712	-713	813	-812	fill=11
c	6205	0	712	-713	812	-811	fill=11
c	6206	0	712	-713	811	-810	fill=11
c	6207	0	712	-713	810	-809	fill=11
c	6208	0	712	-713	809	-808	fill=11
c	6209	0	712	-713	808	-807	fill=11
c	6210	0	712	-713	807	-806	fill=112
c	6211	0	712	-713	806	-805	fill=112
c	6212	0	712	-713	805	-804	fill=112
c	6213	0	712	-713	804	-803	fill=112
c	6214	0	712	-713	803	-802	fill=112
c	6215	0	712	-713	802	-801	fill=112
c	6216	0	712	-713	801	-610	fill=112
c	6217	0	712	-713	610	-615	fill=112
c	6218	0	712	-713	615	-620	fill=112
c	6219	0	712	-713	620	-420	fill=112
c	6220	0	712	-713	420	-430	fill=112
c	6221	0	712	-713	430	-445	fill=112
c	6222	0	712	-713	445	-460	fill=112
c	6223	0	712	-713	460	-675	fill=112
c	6224	0	712	-713	675	-651	fill=112
c	6225	0	712	-713	651	-652	fill=112
c	6226	0	712	-713	652	-653	fill=112
c	6227	0	712	-713	653	-654	fill=112

HOLTEC INTERNATIONAL COPYRIGHTED MATERIAL

HI-STORM FSAR
REPORT HI-2002444

Appendix 5.C-23

Rev. 0

c	6228	0	712	-713	654	-655	fill=112
c	6229	0	712	-713	655	-656	fill=112
c	6230	0	712	-713	656	-657	fill=112
c	6231	0	712	-713	657	-658	fill=112
c	6232	0	712	-713	658	-659	fill=112
c	6233	0	712	-713	659	-680	fill=112
c	6234	0	712	-713	680	-901	fill=112
c	6235	0	712	-713	901	-902	fill=112
c	6236	0	712	-713	902	-903	fill=112
c	6237	0	712	-713	903	-904	fill=112
c	6238	0	712	-713	904	-905	fill=13
c	6239	0	712	-713	905	-906	fill=13
c	6240	0	712	-713	906	-907	fill=13
c	6241	0	712	-713	907	-908	fill=13
c	6242	0	712	-713	908	-909	fill=13
c	6243	8	-7.82	712	-713	909	-910
c	6244	8	-7.82	712	-713	910	-911
c	6245	8	-7.82	712	-713	911	-912
c	6246	8	-7.82	712	-713	912	-913
c	6247	0	712	-713	913	-914	
c	6248	0	712	-713	914	-915	
c	6249	0	712	-713	915	-916	
c	6250	0	712	-713	916	-917	
c	6251	0	712	-713	917	-918	
c							
6300	7	-2.35	713	-714	817	-816	
6301	0		713	-714	816	-815	fill=10
6302	0		713	-714	815	-814	fill=10
6303	0		713	-714	814	-813	fill=11
6304	0		713	-714	813	-812	fill=11
6305	0		713	-714	812	-811	fill=11
6306	0		713	-714	811	-810	fill=11
6307	0		713	-714	810	-809	fill=11
6308	0		713	-714	809	-808	fill=11
6309	0		713	-714	808	-807	fill=11
6310	0		713	-714	807	-806	fill=112
6311	0		713	-714	806	-805	fill=112
6312	0		713	-714	805	-804	fill=112
6313	0		713	-714	804	-803	fill=112
6314	0		713	-714	803	-802	fill=112
6315	0		713	-714	802	-801	fill=112
6316	0		713	-714	801	-610	fill=112
6317	0		713	-714	610	-615	fill=112
6318	0		713	-714	615	-620	fill=112
6319	0		713	-714	620	-420	fill=112
6320	0		713	-714	420	-430	fill=112
6321	0		713	-714	430	-445	fill=112
6322	0		713	-714	445	-460	fill=112
6323	0		713	-714	460	-675	fill=112
6324	0		713	-714	675	-651	fill=112
6325	0		713	-714	651	-652	fill=112
6326	0		713	-714	652	-653	fill=112
6327	0		713	-714	653	-654	fill=112
6328	0		713	-714	654	-655	fill=112
6329	0		713	-714	655	-656	fill=112
6330	0		713	-714	656	-657	fill=112
6331	0		713	-714	657	-658	fill=112
6332	0		713	-714	658	-659	fill=112
6333	0		713	-714	659	-680	fill=112
6334	0		713	-714	680	-901	fill=112
6335	0		713	-714	901	-902	fill=112
6336	0		713	-714	902	-903	fill=112
6337	0		713	-714	903	-904	fill=112
6338	0		713	-714	904	-905	fill=13
6339	0		713	-714	905	-906	fill=13

HOLTEC INTERNATIONAL COPYRIGHTED MATERIAL

HI-STORM FSAR
REPORT HI-2002444

Appendix 5.C-24

Rev. 0

6340	0	713	-714	906	-907	fill=13
6341	0	713	-714	907	-908	fill=13
6342	0	713	-714	908	-909	fill=13
6343	8	-7.82	713	-714	909	-910
6344	8	-7.82	713	-714	910	-911
6345	8	-7.82	713	-714	911	-912
6346	8	-7.82	713	-714	912	-913
c	6347	0	713	-714	913	-914
c	6348	0	713	-714	914	-915
c	6349	0	713	-714	915	-916
c	6350	0	713	-714	916	-917
c	6351	0	713	-714	917	-918
c						
6400	7	-2.35	714	-715	817	-816
6401	0		714	-715	816	-815 fill=10
6402	0		714	-715	815	-814 fill=10
6403	0		714	-715	814	-813 fill=11
6404	0		714	-715	813	-812 fill=11
6405	0		714	-715	812	-811 fill=11
6406	0		714	-715	811	-810 fill=11
6407	0		714	-715	810	-809 fill=11
6408	0		714	-715	809	-808 fill=11
6409	0		714	-715	808	-807 fill=11
6410	0		714	-715	807	-806 fill=112
6411	0		714	-715	806	-805 fill=112
6412	0		714	-715	805	-804 fill=112
6413	0		714	-715	804	-803 fill=112
6414	0		714	-715	803	-802 fill=112
6415	0		714	-715	802	-801 fill=112
6416	0		714	-715	801	-610 fill=112
6417	0		714	-715	610	-615 fill=112
6418	0		714	-715	615	-620 fill=112
6419	0		714	-715	620	-420 fill=112
6420	0		714	-715	420	-430 fill=112
6421	0		714	-715	430	-445 fill=112
6422	0		714	-715	445	-460 fill=112
6423	0		714	-715	460	-675 fill=112
6424	0		714	-715	675	-651 fill=112
6425	0		714	-715	651	-652 fill=112
6426	0		714	-715	652	-653 fill=112
6427	0		714	-715	653	-654 fill=112
6428	0		714	-715	654	-655 fill=112
6429	0		714	-715	655	-656 fill=112
6430	0		714	-715	656	-657 fill=112
6431	0		714	-715	657	-658 fill=112
6432	0		714	-715	658	-659 fill=112
6433	0		714	-715	659	-680 fill=112
6434	0		714	-715	680	-901 fill=112
6435	0		714	-715	901	-902 fill=112
6436	0		714	-715	902	-903 fill=112
6437	0		714	-715	903	-904 fill=112
6438	0		714	-715	904	-905 fill=13
6439	0		714	-715	905	-906 fill=13
6440	0		714	-715	906	-907 fill=13
6441	0		714	-715	907	-908 fill=13
6442	0		714	-715	908	-909 fill=13
6443	0		714	-715	909	-910 fill=15
6444	0		714	-715	910	-911 fill=15
6445	0		714	-715	911	-912 fill=15
6446	0		714	-715	912	-913 fill=15
c	6447	0	714	-715	913	-914
c	6448	0	714	-715	914	-915
c	6449	0	714	-715	915	-916
c	6450	0	714	-715	916	-917
c	6451	0	714	-715	917	-918

HOLTEC INTERNATIONAL COPYRIGHTED MATERIAL

HI-STORM FSAR
REPORT HI-2002444

Appendix 5.C-25

Rev. 0

c
6500 7 -2.35 715 -716 817 -816
6501 0 715 -716 816 -815 fill=10
6502 0 715 -716 815 -814 fill=10
6503 0 715 -716 814 -813 fill=11
6504 0 715 -716 813 -812 fill=11
6505 0 715 -716 812 -811 fill=11
6506 0 715 -716 811 -810 fill=11
6507 0 715 -716 810 -809 fill=11
6508 0 715 -716 809 -808 fill=11
6509 0 715 -716 808 -807 fill=11
6510 0 715 -716 807 -806 fill=12
6511 0 715 -716 806 -805 fill=12
6512 0 715 -716 805 -804 fill=12
6513 0 715 -716 804 -803 fill=12
6514 0 715 -716 803 -802 fill=12
6515 0 715 -716 802 -801 fill=12
6516 0 715 -716 801 -610 fill=12
6517 0 715 -716 610 -615 fill=12
6518 0 715 -716 615 -620 fill=12
6519 0 715 -716 620 -420 fill=12
6520 0 715 -716 420 -430 fill=12
6521 0 715 -716 430 -445 fill=12
6522 0 715 -716 445 -460 fill=12
6523 0 715 -716 460 -675 fill=12
6524 0 715 -716 675 -651 fill=12
6525 0 715 -716 651 -652 fill=12
6526 0 715 -716 652 -653 fill=12
6527 0 715 -716 653 -654 fill=12
6528 0 715 -716 654 -655 fill=12
6529 0 715 -716 655 -656 fill=12
6530 0 715 -716 656 -657 fill=12
6531 0 715 -716 657 -658 fill=12
6532 0 715 -716 658 -659 fill=12
6533 0 715 -716 659 -680 fill=12
6534 0 715 -716 680 -901 fill=12
6535 0 715 -716 901 -902 fill=12
6536 0 715 -716 902 -903 fill=12
6537 0 715 -716 903 -904 fill=12
6538 0 715 -716 904 -905 fill=13
6539 0 715 -716 905 -906 fill=13
6540 0 715 -716 906 -907 fill=13
6541 0 715 -716 907 -908 fill=13
6542 0 715 -716 908 -909 fill=13
6543 0 715 -716 909 -910
6544 0 715 -716 910 -911
6545 0 715 -716 911 -912
6546 0 715 -716 912 -913
c 6547 0 715 -716 913 -914
c 6548 0 715 -716 914 -915
c 6549 0 715 -716 915 -916
c 6550 0 715 -716 916 -917
c 6551 0 715 -716 917 -918
c
6601 0 716 -717 816 -815
6602 0 716 -717 815 -814
6603 0 716 -717 814 -813
6604 0 716 -717 813 -812
6605 0 716 -717 812 -811
6606 0 716 -717 811 -810
6607 0 716 -717 810 -809
6608 0 716 -717 809 -808
6609 0 716 -717 808 -807
6610 0 716 -717 807 -806
6611 0 716 -717 806 -805

HOLTEC INTERNATIONAL COPYRIGHTED MATERIAL

HI-STORM FSAR
REPORT HI-2002444

Appendix 5.C-26

Rev. 0

6612	0	716	-717	805	-804
6613	0	716	-717	804	-803
6614	0	716	-717	803	-802
6615	0	716	-717	802	-801
6616	0	716	-717	801	-610
6617	0	716	-717	610	-615
6618	0	716	-717	615	-620
6619	0	716	-717	620	-420
6620	0	716	-717	420	-430
6621	0	716	-717	430	-445
6622	0	716	-717	445	-460
6623	0	716	-717	460	-675
6624	0	716	-717	675	-651
6625	0	716	-717	651	-652
6626	0	716	-717	652	-653
6627	0	716	-717	653	-654
6628	0	716	-717	654	-655
6629	0	716	-717	655	-656
6630	0	716	-717	656	-657
6631	0	716	-717	657	-658
6632	0	716	-717	658	-659
6633	0	716	-717	659	-680
6634	0	716	-717	680	-901
6635	0	716	-717	901	-902
6636	0	716	-717	902	-903
6637	0	716	-717	903	-904
6638	0	716	-717	904	-905
6639	0	716	-717	905	-906
6640	0	716	-717	906	-907
6641	0	716	-717	907	-908
6642	0	716	-717	908	-909
6643	0	716	-717	909	-910
6644	0	716	-717	910	-911
6645	0	716	-717	911	-912
6646	0	716	-717	912	-913
6647	0	716	-717	913	-914
6648	0	716	-717	914	-915
6649	0	716	-717	915	-916
6650	0	716	-717	916	-917
6651	0	716	-717	917	-918

c

c overpack universes

c overpack baseplate

10001	8	-7.82	371	-372	373	-374	u=10
10002	8	-7.82	374	-362			u=10
10003	8	-7.82	374	363			u=10
10004	9	-1.17e-3	374	362	-363		u=10
10005	8	-7.82	-371	367	-374		u=10
10006	8	-7.82	-371	373	-366		u=10
10007	9	-1.17e-3	-371	366	-367		u=10
10008	8	-7.82	-373	-362			u=10
10009	8	-7.82	-373	363			u=10
10010	9	-1.17e-3	-373	362	-363		u=10
10011	8	-7.82	372	373	-366		u=10
10012	8	-7.82	372	367	-374		u=10
10013	9	-1.17e-3	372	366	-367		u=10

c

c walls and top of bottom duct

10101	8	-7.82	361	-362	-932		u=11
10102	8	-7.82	363	-364	-932		u=11
10103	8	-7.82	362	-363	931	-932	u=11

c

10104	8	-7.82	365	-366	-932		u=11
10105	8	-7.82	367	-368	-932		u=11
10106	8	-7.82	366	-367	931	-932	u=11

HOLTEC INTERNATIONAL COPYRIGHTED MATERIAL

HI-STORM FSAR
REPORT HI-2002444

Appendix 5.C-27

Rev. 0

```

c      inner and outer shell between bottom ducts
10107 8 -7.82      368 364 -932 315      u=11
10108 8 -7.82      368 -361 -932 315      u=11
10109 8 -7.82      -365 364 -932 315      u=11
10110 8 -7.82      -365 -361 -932 315      u=11
c
10111 8 -7.82      368 364 -932 -310      u=11
10112 8 -7.82      368 -361 -932 -310      u=11
10113 8 -7.82      -365 364 -932 -310      u=11
10114 8 -7.82      -365 -361 -932 -310      u=11
c      concrete and radial plates between bottom ducts
10121 8 -7.82      310 -315 391 -392      -932 u=11
10122 8 -7.82      310 -315 393 -394      -932 u=11
c
10131 7 -2.35      310 -315 394 -365      -932 u=11
10132 7 -2.35      310 -315 368 -391      -932 u=11
10133 7 -2.35      310 -315 392 364      -932 u=11
10134 7 -2.35      310 -315 -361 394      -932 u=11
10135 7 -2.35      310 -315 368 -393      -932 u=11
10136 7 -2.35      310 -315 392 -365      -932 u=11
10137 7 -2.35      310 -315 -391 -361      -932 u=11
10138 7 -2.35      310 -315 364 -393      -932 u=11
c      air and grid spacers in bottom ducts
10141 9 -1.17e-3    362 -363 -931 263 -264      u=11
10142 9 -1.17e-3    366 -367 -931 261 -262      u=11
c
10143 9 -1.17e-3    362 -201 -931 (-263:264) u=11
10144 9 -1.17e-3    206 -363 -931 (-263:264) u=11
10145 9 -1.17e-3    201 -202 -221 (-263:264) u=11
10146 5 -7.92      202 -203 -221 (-273:274) u=11
11146 9 -1.17e-3    202 -203 -221 273 -274 (-263:264) u=11
10147 9 -1.17e-3    203 -204 -221 (-263:264) u=11
10148 5 -7.92      204 -205 -221 (-273:274) u=11
11148 9 -1.17e-3    204 -205 -221 273 -274 (-263:264) u=11
10149 9 -1.17e-3    205 -206 -221 (-263:264) u=11
10150 5 -7.92      201 -202 221 -222 (-263:264) u=11
10151 5 -7.92      202 -203 221 -222 (-263:264) u=11
10152 5 -7.92      203 -204 221 -222 (-263:264) u=11
10153 5 -7.92      204 -205 221 -222 (-263:264) u=11
10154 5 -7.92      205 -206 221 -222 (-263:264) u=11
10155 9 -1.17e-3    201 -202 222 -223 (-263:264) u=11
10156 5 -7.92      202 -203 222 -223 (-263:264) u=11
10157 9 -1.17e-3    203 -204 222 -223 (-263:264) u=11
10158 5 -7.92      204 -205 222 -223 (-263:264) u=11
10159 9 -1.17e-3    205 -206 222 -223 (-263:264) u=11
10160 5 -7.92      201 -202 223 -224 (-263:264) u=11
10161 5 -7.92      202 -203 223 -224 (-263:264) u=11
10162 5 -7.92      203 -204 223 -224 (-263:264) u=11
10163 5 -7.92      204 -205 223 -224 (-263:264) u=11
10164 5 -7.92      205 -206 223 -224 (-263:264) u=11
10165 9 -1.17e-3    201 -202 224 -225 (-263:264) u=11
10166 5 -7.92      202 -203 224 -225 (-263:264) u=11
10167 9 -1.17e-3    203 -204 224 -225 (-263:264) u=11
10168 5 -7.92      204 -205 224 -225 (-263:264) u=11
10169 9 -1.17e-3    205 -206 224 -225 (-263:264) u=11
10170 9 -1.17e-3    201 -206 225 -931 (-263:264) u=11
c
10243 9 -1.17e-3    366 -211 -931 (-261:262) u=11
10244 9 -1.17e-3    216 -367 -931 (-261:262) u=11
10245 9 -1.17e-3    211 -212 -221 (-261:262) u=11
10246 5 -7.92      212 -213 -221 (-261:262) u=11
10247 9 -1.17e-3    213 -214 -221 (-261:262) u=11
10248 5 -7.92      214 -215 -221 (-261:262) u=11
10249 9 -1.17e-3    215 -216 -221 (-261:262) u=11
10250 5 -7.92      211 -212 221 -222 (-261:262) u=11

```

HOLTEC INTERNATIONAL COPYRIGHTED MATERIAL

HI-STORM FSAR
REPORT HI-2002444

Appendix 5.C-28

Rev. 0

10251 5 -7.92 212 -213 221 -222 (-261:262) u=11
 10252 5 -7.92 213 -214 221 -222 (-261:262) u=11
 10253 5 -7.92 214 -215 221 -222 (-261:262) u=11
 10254 5 -7.92 215 -216 221 -222 (-261:262) u=11
 10255 9 -1.17e-3 211 -212 222 -223 (-261:262) u=11
 10256 5 -7.92 212 -213 222 -223 (-261:262) u=11
 10257 9 -1.17e-3 213 -214 222 -223 (-261:262) u=11
 10258 5 -7.92 214 -215 222 -223 (-261:262) u=11
 10259 9 -1.17e-3 215 -216 222 -223 (-261:262) u=11
 10260 5 -7.92 211 -212 223 -224 (-261:262) u=11
 10261 5 -7.92 212 -213 223 -224 (-261:262) u=11
 10262 5 -7.92 213 -214 223 -224 (-261:262) u=11
 10263 5 -7.92 214 -215 223 -224 (-261:262) u=11
 10264 5 -7.92 215 -216 223 -224 (-261:262) u=11
 10265 9 -1.17e-3 211 -212 224 -225 (-261:262) u=11
 10266 5 -7.92 212 -213 224 -225 (-261:262) u=11
 10267 9 -1.17e-3 213 -214 224 -225 (-261:262) u=11
 10268 5 -7.92 214 -215 224 -225 (-261:262) u=11
 10269 9 -1.17e-3 215 -216 224 -225 (-261:262) u=11
 10270 9 -1.17e-3 211 -216 225 -931 (-261:262) u=11

c

c inner, outer shells and concrete between top and bot ducts

c

10301 8 -7.82 932 -311 u=11
 10302 8 -7.82 932 315 u=11
 10303 8 -7.82 932 311 -315 391 -392 u=11
 10304 8 -7.82 932 311 -315 393 -394 u=11
 10305 7 -2.35 932 311 -315 394 -391 u=11
 10306 7 -2.35 932 311 -315 392 394 u=11
 10307 7 -2.35 932 311 -315 392 -393 u=11
 10308 7 -2.35 932 311 -315 -391 -393 u=11

c

11302 8 -7.82 315 u=12
 11303 8 -7.82 -315 391 -392 u=12
 11304 8 -7.82 -315 393 -394 u=12
 11305 7 -2.35 -315 394 -391 u=12
 11306 7 -2.35 -315 392 394 u=12
 11307 7 -2.35 -315 392 -393 u=12
 11308 7 -2.35 -315 -391 -393 u=12

c

13303 8 -7.82 391 -392 u=112
 13304 8 -7.82 393 -394 u=112
 13305 7 -2.35 394 -391 u=112
 13306 7 -2.35 392 394 u=112
 13307 7 -2.35 392 -393 u=112
 13308 7 -2.35 -391 -393 u=112

c

12301 8 -7.82 -933 -311 u=13
 12302 8 -7.82 -933 315 u=13
 12303 8 -7.82 -933 311 -315 391 -392 u=13
 12304 8 -7.82 -933 311 -315 393 -394 u=13
 12305 7 -2.35 -933 311 -315 394 -391 u=13
 12306 7 -2.35 -933 311 -315 392 394 u=13
 12307 7 -2.35 -933 311 -315 392 -393 u=13
 12308 7 -2.35 -933 311 -315 -391 -393 u=13

c

top duct bottom plates
 10309 8 -7.82 933 -934 351 -354 u=13
 10310 8 -7.82 933 -934 355 -358 u=13

c

top duct walls
 10311 8 -7.82 934 351 -352 u=13
 10312 8 -7.82 934 353 -354 u=13
 10313 8 -7.82 934 355 -356 u=13
 10314 8 -7.82 934 357 -358 u=13

c

inner and outer shell between top ducts
 10407 8 -7.82 358 354 933 315 u=13

HOLTEC INTERNATIONAL COPYRIGHTED MATERIAL

HI-STORM FSAR
 REPORT HI-2002444

Appendix 5.C-29

Rev. 0

10408	8	-7.82	358	-351	933	315	u=13
10409	8	-7.82	-355	354	933	315	u=13
10410	8	-7.82	-355	-351	933	315	u=13
c							
10411	8	-7.82	358	354	933	-310	u=13
10412	8	-7.82	358	-351	933	-310	u=13
10413	8	-7.82	-355	354	933	-310	u=13
10414	8	-7.82	-355	-351	933	-310	u=13
c							concrete and radial plates next to top ducts
10421	8	-7.82	310	-315	391	-392	933 -935 u=13
10422	8	-7.82	310	-315	393	-394	933 -935 u=13
c							
10431	7	-2.35	310	-315	394	-355	933 -935 u=13
10432	7	-2.35	310	-315	358	-391	933 -935 u=13
10433	7	-2.35	310	-315	392	354	933 -935 u=13
10434	7	-2.35	310	-315	-351	394	933 -935 u=13
10435	7	-2.35	310	-315	358	-393	933 -935 u=13
10436	7	-2.35	310	-315	392	-355	933 -935 u=13
10437	7	-2.35	310	-315	-391	-351	933 -935 u=13
10438	7	-2.35	310	-315	354	-393	933 -935 u=13
c							
c							air and grid spacers in top ducts
10441	9	-1.17e-3	352	-353	934	263	-264 u=13
10442	9	-1.17e-3	356	-357	934	261	-262 u=13
c							
10443	9	-1.17e-3	352	-231	934	(-263:264)	u=13
10444	9	-1.17e-3	236	-353	934	(-263:264)	u=13
c							
10445	9	-1.17e-3	231	-232	934	-251	(-263:264) u=13
10446	5	-7.92	232	-233	934	-251	(-263:264) u=13
10447	9	-1.17e-3	233	-234	934	-251	(-263:264) u=13
10448	5	-7.92	234	-235	934	-251	(-263:264) u=13
10449	9	-1.17e-3	235	-236	934	-251	(-263:264) u=13
10450	5	-7.92	231	-232	251	-252	(-263:264) u=13
10451	5	-7.92	232	-233	251	-252	(-263:264) u=13
10452	5	-7.92	233	-234	251	-252	(-263:264) u=13
10453	5	-7.92	234	-235	251	-252	(-263:264) u=13
10454	5	-7.92	235	-236	251	-252	(-263:264) u=13
10455	9	-1.17e-3	231	-232	252	-253	(-263:264) u=13
10456	5	-7.92	232	-233	252	-253	(-263:264) u=13
10457	9	-1.17e-3	233	-234	252	-253	(-263:264) u=13
10458	5	-7.92	234	-235	252	-253	(-263:264) u=13
10459	9	-1.17e-3	235	-236	252	-253	(-263:264) u=13
10470	9	-1.17e-3	231	-236	253		(-263:264) u=13
c							
10543	9	-1.17e-3	356	-241	934	(-261:262)	u=13
10544	9	-1.17e-3	246	-357	934	(-261:262)	u=13
c							
10545	9	-1.17e-3	241	-242	934	-251	(-261:262) u=13
10546	5	-7.92	242	-243	934	-251	(-261:262) u=13
10547	9	-1.17e-3	243	-244	934	-251	(-261:262) u=13
10548	5	-7.92	244	-245	934	-251	(-261:262) u=13
10549	9	-1.17e-3	245	-246	934	-251	(-261:262) u=13
10550	5	-7.92	241	-242	251	-252	(-261:262) u=13
10551	5	-7.92	242	-243	251	-252	(-261:262) u=13
10552	5	-7.92	243	-244	251	-252	(-261:262) u=13
10553	5	-7.92	244	-245	251	-252	(-261:262) u=13
10554	5	-7.92	245	-246	251	-252	(-261:262) u=13
10555	9	-1.17e-3	241	-242	252	-253	(-261:262) u=13
10556	5	-7.92	242	-243	252	-253	(-261:262) u=13
10557	9	-1.17e-3	243	-244	252	-253	(-261:262) u=13
10558	5	-7.92	244	-245	252	-253	(-261:262) u=13
10559	9	-1.17e-3	245	-246	252	-253	(-261:262) u=13
10570	9	-1.17e-3	241	-246	253		(-261:262) u=13
c							top plate

HOLTEC INTERNATIONAL COPYRIGHTED MATERIAL

HI-STORM FSAR
REPORT HI-2002444

Appendix 5.C-30

Rev. 0

```

10641 8 -7.82      358 354 935 310 -315 u=13
10642 8 -7.82      358 -351 935 310 -315 u=13
10643 8 -7.82     -355 354 935 310 -315 u=13
10644 8 -7.82     -355 -351 935 310 -315 u=13
c
10701 8 -7.82     -314 u=15
10702 0          314 u=15
c
10711 7 -2.35     -312      u=14
10712 8 -7.82      312 -313 u=14
10713 0          313      u=14
c
99999 0 -817:918:717:(716 -816)
c
c      BLANK LINE

c      BLANK LINE
c
c      MPC surfaces\ / \ / \ / \ / \ /
c
10      px      -12.169775
11      px      -12.017375
12      px      -11.826875
13      px      -11.1125
14      px      11.1125
15      px      11.826875
16      px      12.017375
17      px      12.169775
18      py      -12.169775
19      py      -12.017375
20      py      -11.826875
21      py      -11.1125
22      py      11.1125
23      py      11.826875
24      py      12.017375
25      py      12.169775
c
26      py      -9.525
27      py      9.525
28      px      -9.525
29      px      9.525
30      py      -6.35
31      py      6.35
32      px      -6.35
33      px      6.35
c
35      px      -11.46969
36      px      11.46969
37      py      -11.46969
38      py      11.46969
c
40      px      -10.8204
41      px      10.8204
42      py      -10.8204
43      py      10.8204
c
101     py      82.12074
102     py      54.74716
103     py      27.37358
104     py      0.0
105     py      -27.37358
106     py      -54.74716
107     py      -82.12074
c
116     px      82.12074

```

HOLTEC INTERNATIONAL COPYRIGHTED MATERIAL

HI-STORM FSAR
REPORT HI-2002444

Appendix 5.C-31

Rev. 0

115	px	54.74716		
114	px	27.37358		
113	px	0.0		
112	px	-27.37358		
111	px	-54.74716		
110	px	-82.12074		
c				
301	cz	85.56625		
302	cz	86.83625		
c				
c	620	pz	21.59	\$ MPC baseplate - 2.5 inches
400	pz	23.876		\$ start of egg crate
410	pz	28.8925		\$ start of boral
415	pz	32.004		\$ begin fuel element
420	pz	50.7365		\$ end of lower nozzle
425	pz	53.2765		\$ end of space/ start of active fuel
430	pz	419.0365		\$ end of active fuel
435	pz	425.1325		\$ boral ends
440	pz	428.72025		\$ space above fuel
445	pz	439.83275		\$ plenum spacer ends
455	pz	452.6915		\$ top of top nozzle
460	pz	467.614		\$ top of basket
c				
610	pz	15.24		\$ overpack baseplate
615	pz	17.78		
616	pz	20.32		
620	pz	21.59		\$ MPC baseplate - 2.5 inches
675	pz	474.98		\$ bottom of MPC in lid - 178.5 inches from 620
651	pz	476.25		\$ 0.25 inch first segment
652	pz	478.79		
653	pz	481.33		
654	pz	483.87		
655	pz	486.41		
656	pz	488.95		
657	pz	491.49		
658	pz	494.03		
659	pz	496.57		
680	pz	499.11		\$ top of MPC outer lid
c				
c	MPC surfaces/\ / \ / \ / \ /			
c				
c	overpack surfaces			
c				
303	cz	80.01		\$ ID of item 27
304	cz	81.28		\$ OD of item 27
305	cz	85.09		\$ ID of item 7
306	cz	86.20125		\$ ID of item 5
307	cz	87.63		\$ OD of item 7
c				
310	cz	96.52		\$ outer rad of item 3 overpack inner shell
311	cz	98.425		\$ outer rad of item 28
312	cz	107.95		\$ ID of item 26
313	cz	109.22		\$ OD of item 26
314	cz	160.02		\$ OD of item 10
315	cz	166.37		\$ ID of item 2
c				
top duct planes				
351	px	-33.02		\$ start of item 12
352	px	-31.75		\$ end of item 12
353	px	31.75		\$ start of item 12
354	px	33.02		\$ end of item 12
c				
355	py	-33.02		\$ start of item 12
356	py	-31.75		\$ end of item 12
357	py	31.75		\$ start of item 12
358	py	33.02		\$ end of item 12

HOLTEC INTERNATIONAL COPYRIGHTED MATERIAL

HI-STORM FSAR
REPORT HI-2002444

Appendix 5.C-32

Rev. 0

```

c    bottom duct planes
361  px    -20.955  $ start of item 13
362  px    -19.05   $ end of item 13
363  px     19.05   $ start of item 13
364  px     20.955  $ end of item 13
c
365  py    -20.955  $ start of item 13
366  py    -19.05   $ end of item 13
367  py     19.05   $ start of item 13
368  py     20.955  $ end of item 13
c    cutouts in item 1
371  px    -123.19
372  px     123.19
373  py    -123.19
374  py     123.19
c    item 14
391  1 py    -0.9525  $ steel plate in concrete at 45/225 degrees
392  1 py     0.9525  $ steel plate in concrete at 45/225 degrees
393  1 px    -0.9525  $ steel plate in concrete at 135/315 degrees
394  1 px     0.9525  $ steel plate in concrete at 135/315 degrees
c
c    bottom shielding cross plates
c
201  px    -18.57375
202  px     -6.35
203  px    -5.715
204  px     5.715
205  px     6.35
206  px    18.57375
c
211  py    -18.57375
212  py     -6.35
213  py    -5.715
214  py     5.715
215  py     6.35
216  py    18.57375
c
221  pz    -32.8168
222  pz    -32.1818
223  pz    -24.3586
224  pz    -23.7236
225  pz    -15.9004
c
c    top shielding cross plates
c
231  px    -31.27375
232  px    -10.795
233  px    -10.16
234  px     10.16
235  px     10.795
236  px    31.27375
c
241  py    -31.27375
242  py    -10.795
243  py    -10.16
244  py     10.16
245  py     10.795
246  py    31.27375
c
251  pz     523.24
252  pz     523.875
253  pz     530.86
c    end of cross plates in openings
261  px    -107.315
262  px     107.315

```

HOLTEC INTERNATIONAL COPYRIGHTED MATERIAL

HI-STORM FSAR
REPORT HI-2002444

Appendix 5.C-33

Rev. 0

263 py -107.315
 264 py 107.315
 c end of part of bottom cross plates
 271 px -124.46
 272 px 124.46
 273 py -124.46
 274 py 124.46
 c
 c radial planes in overpack
 700 cz 93.345 \$ ID of overpack
 701 cz 95.885
 702 cz 98.5 \$ slightly diff from 311
 703 cz 103.505
 704 cz 108.585
 705 cz 113.665
 706 cz 118.745
 707 cz 123.825
 708 cz 128.905
 709 cz 133.985
 710 cz 139.065
 711 cz 144.145
 712 cz 149.225
 713 cz 154.305
 714 cz 159.385
 715 cz 164.465
 716 cz 168.275
 717 cz 169.275
 c
 c planes in pedestal
 c
 801 pz 12.7
 802 pz 10.16
 803 pz 7.62
 804 pz 5.08
 805 pz 2.54 \$ bottom of item 24
 806 pz -2.54
 807 pz -7.62
 808 pz -12.7
 809 pz -17.78
 810 pz -22.86
 811 pz -27.94
 812 pz -33.02
 813 pz -38.1
 814 pz -40.64 \$ start of item 1
 815 pz -43.18 \$
 816 pz -45.72 \$ ground
 817 pz -76.20
 c
 c planes in lid
 c
 901 pz 501.65 \$ start of item 6
 902 pz 502.285 \$ 0.25 inch segment from start
 903 pz 504.825 \$ end of item 6
 904 pz 509.905
 905 pz 513.715
 906 pz 516.3 \$ end of item 8 plus a little
 907 pz 521.335
 908 pz 526.415
 909 pz 531.495 \$ end of concrete start of item 10
 910 pz 534.035
 911 pz 536.575
 912 pz 539.115
 913 pz 541.655 \$ end of item 10
 914 pz 546.735
 915 pz 551.815

HOLTEC INTERNATIONAL COPYRIGHTED MATERIAL

HI-STORM FSAR
 REPORT HI-2002444

Appendix 5.C-34

Rev. 0

916	pz	556.895	
917	pz	561.975	
918	pz	562.975	
c			
c	planes in overpack		
c			
931	pz	-15.24	\$ bottom of item 11
932	pz	-10.16	\$ top of item 11
933	pz	513.08	\$ bottom of item 8 and top of item 28
934	pz	516.255	\$ top of item 8
935	pz	529.59	\$ start of item 9
c			
c	for tallying		
c			
501	pz	-45.72	
502	pz	-30.48	
503	pz	-15.24	
504	pz	0.00	
505	pz	15.24	
506	pz	30.48	
507	pz	45.72	
508	pz	60.96	
509	pz	76.20	
510	pz	91.44	
511	pz	106.68	
512	pz	121.92	
513	pz	137.16	
514	pz	152.40	
515	pz	167.64	
516	pz	182.88	
517	pz	198.12	
518	pz	213.36	
519	pz	228.60	
520	pz	243.84	
521	pz	259.08	
522	pz	274.32	
523	pz	289.56	
524	pz	304.80	
525	pz	320.04	
526	pz	335.28	
527	pz	350.52	
528	pz	365.76	
529	pz	381.00	
530	pz	396.24	
531	pz	411.48	
532	pz	426.72	
533	pz	441.96	
534	pz	457.20	
535	pz	472.44	
536	pz	487.68	
537	pz	502.92	
538	pz	518.16	
539	pz	533.40	
c			
550	cz	15.24	
551	cz	30.48	
552	cz	45.72	
553	cz	60.96	
554	cz	76.20	
555	cz	91.44	
556	cz	106.68	
557	cz	121.92	
558	cz	137.16	
559	cz	152.40	
560	cz	167.64	

HOLTEC INTERNATIONAL COPYRIGHTED MATERIAL

HI-STORM FSAR
REPORT HI-2002444

Appendix 5.C-35

Rev. 0

```

c
c BLANK LINE

c BLANK LINE
c
*tr1 0 0 0 45 315 90 135 45 90 90 90 0
c
c PHOTON MATERIALS
c
c fuel 3.4 w/o U235 10.412 gm/cc
m1 92235.01p -0.029971
92238.01p -0.851529
8016.01p -0.1185
c homogenized fuel density 3.8699 gm/cc
m2 92235.01p -0.027652
92238.01p -0.719715
8016.01p -0.100469
40000.01p -0.149015
50000.01p -0.002587
26000.01p -0.000365
24000.01p -0.000198
c zirconium 6.55 gm/cc
m3 40000.01p 1. $ Zr Clad
c stainless steel 7.92 gm/cc
m5 24000.01p -0.19
25055.01p -0.02
26000.01p -0.695
28000.01p -0.095
c boral 2.644 gm/cc
m6 5010.01p -0.044226
5011.01p -0.201474
13027.01p -0.6861
6000.01p -0.0682
c Concrete (NBS Ordinary) @ 2.35 g/cc (Ref: LA-12827-M)
m7 14000.01p -0.315
13027.01p -0.048
8016.01p -0.500
1001.01p -0.006
11023.01p -0.017
20000.01p -0.083
26000.01p -0.012
19000.01p -0.019
c carbon steel 7.82 gm/cc
m8 6000.01p -0.005 26000.01p -0.995
c air density 1.17e-3 gm/cc
m9 7014.01p 0.78 8016.01p 0.22
c
c NEUTRON MATERIALS
c
c fuel 3.4 w/o U235 10.412 gm/cc
c m1 92235.50c -0.029971
92238.50c -0.851529
8016.50c -0.1185
c homogenized fuel density 3.8699 gm/cc
c m2 92235.50c -0.027652
92238.50c -0.719715
8016.50c -0.100469
40000.35c -0.149015
50000.35c -0.002587
26000.55c -0.000365
24000.50c -0.000198
c helium 1e-4 gm/cc
c m3 2004.50c 1.0
c stainless steel 7.92 gm/cc
c m5 24000.50c -0.19

```

HOLTEC INTERNATIONAL COPYRIGHTED MATERIAL

HI-STORM FSAR
REPORT HI-2002444

Appendix 5.C-36

Rev. 0

```

c          25055.50c  -0.02
c          26000.55c  -0.695
c          28000.50c  -0.095
c    c      boral  2.644 gm/cc
c    m6      5010.50c  -0.044226
c          5011.56c  -0.201474
c          13027.50c  -0.6861
c          6000.50c   -0.0682
c    c      Concrete (NBS Ordinary) @ 2.35 g/cc (Ref: LA-12827-M)
c    m7      14000.50c  -0.315
c          13027.50c  -0.048
c          8016.50c   -0.500
c          1001.50c   -0.006
c          11023.50c  -0.017
c          20000.50c  -0.083
c          26000.55c  -0.012
c          19000.50c  -0.019
c    mt7     lwtr.01t
c    c      carbon steel 7.82 gm/cc
c    m8      6000.50c  -0.005 26000.55c -0.995
c    c      air density 1.17e-3 gm/cc
c    m9      7014.50c  0.78 8016.50c 0.22
c
phys:n  20 0.0
phys:p  100 0
c    imp:n  1 228r 0
c    imp:p  1 228r 0
nps    13500000
prtmp  j  -60  1  2
c    print  10 110 160 161 20 170
print
mode p
ssw    716 917
c
sdef  par=2  erg=d1  axs=0 0 1  x=d4  y=fx  d5  z=d3
c
c    energy dist for gammas in the fuel
c
c    sil  h  0.7 1.0 1.5 2.0 2.5 3.0
c    spl  0  0.43 0.27 0.22 0.04 0.04
c
c    energy dist for neutrons in the fuel
c
c    sil  h  0.1 0.4 0.9 1.4 1.85 3.0 6.43 20.0
c    spl  0  0.03787 0.1935 0.1773 0.1310 0.2320 0.2098 0.01853
c
c    energy dist for Co60 gammas
c
sil  1 1.3325 1.1732
spl  0.5  0.5
c
c    axial dist for phot in fuel
c
c    si3  h  53.2765 68.5165 83.7565 114.2365 175.1965 236.1565
c          297.1165 358.0765 388.5565 403.7965 419.0365
c    sp3  0  0.022854 0.035321 0.08975 0.184167 0.183 0.179833
c          0.175017 0.080033 0.030575 0.019458
c    sb3  0  1 1 1 1 1 1 1 1 1 1
c
c    axial dist for Co60 - a zero prob is in the fuel
c
si3  h  32.004 50.7365 419.0365 428.72025 439.83275 452.6915
sp3  0  0.44  0.0  0.05  0.05  0.46
sb3  0  0.50  0.0  0.05  0.10  0.35
c

```

HOLTEC INTERNATIONAL COPYRIGHTED MATERIAL

HI-STORM FSAR
REPORT HI-2002444

Appendix 5.C-37

Rev. 0

```

si4 s      13 14
           12 13 14 15
           11 12 13 14 15 16
           11 12 13 14 15 16
           12 13 14 15
           13 14

sp4 1 23r
c
ds5 s      26 26
           25 25 25 25
           24 24 24 24 24 24
           23 23 23 23 23 23
           22 22 22 22
           21 21

```

```

c
si11 -79.25435 -57.61355
si12 -51.88077 -30.23997
si13 -24.50719 -2.86639
si14  2.86639  24.50719
si15 30.23997 51.88077
si16 57.61355 79.25435

```

```

c
si21 -79.25435 -57.61355
si22 -51.88077 -30.23997
si23 -24.50719 -2.86639
si24  2.86639  24.50719
si25 30.23997 51.88077
si26 57.61355 79.25435

```

```

c
sp11 0 1
sp12 0 1
sp13 0 1
sp14 0 1
sp15 0 1
sp16 0 1
sp21 0 1
sp22 0 1
sp23 0 1
sp24 0 1
sp25 0 1
sp26 0 1

```

```

c
# imp:p
314 2
315 2
316 2
317 2
318 2
319 2
320 2
321 2
346 2
353 2
360 2
361 2
362 2
363 2
364 2
365 2
366 2
367 2
414 2
415 2
416 2
417 2

```

HOLTEC INTERNATIONAL COPYRIGHTED MATERIAL

HI-STORM FSAR
REPORT HI-2002444

Appendix 5.C-38

Rev: 0

418 2
419 2
420 2
421 2
446 2
453 2
460 2
461 2
462 2
463 2
464 2
465 2
466 2
467 2
514 2
515 2
516 2
517 2
518 2
519 2
520 2
521 2
546 2
553 2
560 2
561 2
562 2
563 2
564 2
565 2
566 2
567 2
614 2
615 2
616 2
617 2
618 2
619 2
620 2
621 2
646 2
653 2
660 2
661 2
662 2
663 2
664 2
665 2
666 2
667 2
714 2
715 2
716 2
717 2
718 2
719 2
720 2
721 2
746 2
753 2
760 2
761 2
762 2
763 2
764 2

HOLTEC INTERNATIONAL COPYRIGHTED MATERIAL

HI-STORM FSAR
REPORT HI-2002444

Appendix 5.C-39

Rev. 0

765 2
766 2
767 2
322 1
323 1
324 1
325 1
326 1
327 1
328 1
329 1
347 1
355 1
368 1
369 1
370 1
371 1
372 1
373 1
374 1
375 1
422 1
423 1
424 1
425 1
426 1
427 1
428 1
429 1
447 1
455 1
468 1
469 1
470 1
471 1
472 1
473 1
474 1
475 1
522 1
523 1
524 1
525 1
526 1
527 1
528 1
529 1
547 1
555 1
568 1
569 1
570 1
571 1
572 1
573 1
574 1
575 1
622 1
623 1
624 1
625 1
626 1
627 1
628 1
629 1

HOLTEC INTERNATIONAL COPYRIGHTED MATERIAL

HI-STORM FSAR
REPORT HI-2002444

Appendix 5.C-40

Rev.0

647 1
655 1
668 1
669 1
670 1
671 1
672 1
673 1
674 1
675 1
722 1
723 1
724 1
725 1
726 1
727 1
728 1
729 1
747 1
755 1
768 1
769 1
770 1
771 1
772 1
773 1
774 1
775 1
330 2
331 2
332 2
333 2
334 2
335 2
336 2
337 2
348 2
356 2
357 2
376 2
377 2
378 2
379 2
380 2
381 2
382 2
383 2
430 2
431 2
432 2
433 2
434 2
435 2
436 2
437 2
448 2
456 2
457 2
476 2
477 2
478 2
479 2
480 2
481 2
482 2

HOLTEC INTERNATIONAL COPYRIGHTED MATERIAL

HI-STORM FSAR
REPORT HI-2002444

Appendix 5.C-41

Rev. 0

483 2
530 2
531 2
532 2
533 2
534 2
535 2
536 2
537 2
548 2
556 2
557 2
576 2
577 2
578 2
579 2
580 2
581 2
582 2
583 2
630 2
631 2
632 2
633 2
634 2
635 2
636 2
637 2
648 2
656 2
657 2
676 2
677 2
678 2
679 2
680 2
681 2
682 2
683 2
730 2
731 2
732 2
733 2
734 2
735 2
736 2
737 2
748 2
756 2
757 2
776 2
777 2
778 2
779 2
780 2
781 2
782 2
783 2
349 4
358 4
384 4
385 4
386 4
387 4
388 4

HOLTEC INTERNATIONAL COPYRIGHTED MATERIAL

HI-STORM FSAR
REPORT HI-2002444

Appendix 5.C-42

Rev.0

389	4
390	4
391	4
449	4
458	4
484	4
485	4
486	4
487	4
488	4
489	4
490	4
491	4
549	4
558	4
584	4
585	4
586	4
587	4
588	4
589	4
590	4
591	4
649	4
658	4
684	4
685	4
686	4
687	4
688	4
689	4
690	4
691	4
749	4
758	4
784	4
785	4
786	4
787	4
788	4
789	4
790	4
791	4
351	8
451	8
551	8
651	8
751	8
1051	16
1052	8
1053	4
1060	24
1061	24
1062	72
1063	72
1064	216
1065	216
1066	648
1067	648
1068	1944
1069	1944
1001	16
1003	8
1005	8
1007	4

HOLTEC INTERNATIONAL COPYRIGHTED MATERIAL

HI-STORM FSAR
REPORT HI-2002444

Appendix 5.C-43

Rev. 0

1009	2
1011	4
1013	8
1014	16
1015	48
1017	24
1019	72
1021	72
1023	216
1025	216
1027	648
1028	648
1029	1944
1031	1944
c	
2001	32
2002	64
2003	128
2004	256
2005	512
2006	1024
2007	1024
2008	2048
2009	2048
2010	4096
2011	4096
2012	8192
2013	8192
2014	16384
c	
2016	1024
2017	1024
2028	2048
2019	2048
2020	4096
2021	4096
2022	8192
2023	8192
2024	16384
c	
2031	16384
2032	16384
2033	16384
c	
3001	3888
3002	3888
3003	3888
c	
3004	7776
3005	7776
3006	7776
3007	7776
3008	15552
3009	15552
c	
3010	7776
3011	7776
3012	7776
3013	7776
3014	15552
3015	15552
c	
3021	46656
3022	46656
3023	139968

HOLTEC INTERNATIONAL COPYRIGHTED MATERIAL

HI-STORM FSAR
REPORT HI-2002444

Appendix 5.C-44

Rev. 0

3024	139968
c	
3030	1
3031	1
3032	1
3033	1
3034	1
c	
3035	279936
3036	279936
3037	559872
3038	559872
3039	1
c	
3040	279936
3041	279936
3042	559872
3043	559872
3044	1
c	
4000	32768
4001	32768
4002	32768
4003	32768
4004	16384
4005	16384
4006	8192
4007	8192
4008	4096
4009	4096
4010	2048
4011	2048
4012	1024
4013	512
4014	256
4015	128
4016	64
4017	32
4018	16
4019	8
4020	4
4021	8
4022	16
4023	32
4024	96
4025	48
4026	144
4027	144
4028	432
4029	432
4030	1296
4031	1296
4032	3888
4033	3888
4034	7776
4035	7776
4036	7776
4037	15552
4038	15552
4039	15552
4040	15552
4041	31104
4042	31104
4043	93312
4044	93312

HOLTEC INTERNATIONAL COPYRIGHTED MATERIAL

HI-STORM FSAR
REPORT HI-2002444

Appendix 5.C-45

Rev: 0

4045	279936
4046	279936
4047	559872
4048	559872
4049	1119744
4050	1119744
4051	1

c

5000	32768
5001	32768
5002	32768
5003	32768
5004	16384
5005	16384
5006	8192
5007	8192
5008	4096
5009	4096
5010	2048
5011	2048
5012	1024
5013	512
5014	256
5015	128
5016	64
5017	32
5018	16
5019	8
5020	4
5021	8
5022	16
5023	32
5024	96
5025	48
5026	144
5027	144
5028	432
5029	432
5030	1296
5031	1296
5032	3888
5033	3888
5034	7776
5035	7776
5036	7776
5037	15552
5038	15552
5039	15552
5040	15552
5041	31104
5042	31104
5043	93312
5044	93312
5045	279936
5046	279936
5047	559872
5048	559872
5049	1119744
5050	1119744
5051	1

c

5100	65536
5101	65536
5102	65536
5103	65536

HOLTEC INTERNATIONAL COPYRIGHTED MATERIAL

HI-STORM FSAR
REPORT HI-2002444

Appendix 5.C-46

Rev. 0

5104	32768
5105	32768
5106	16384
5107	16384
5108	8192
5109	8192
5110	4096
5111	4096
5112	2048
5113	1024
5114	512
5115	256
5116	128
5117	64
5118	32
5119	16
5120	8
5121	16
5122	32
5123	64
5124	192
5125	96
5126	288
5127	288
5128	864
5129	864
5130	2592
5131	2592
5132	7776
5133	7776
5134	15552
5135	15552
5136	15552
5137	31104
5138	31104
5139	31104
5140	31104
5141	62208
5142	62208
5143	186624
5144	186624
5145	559872
5146	559872
5147	1119744
5148	1119744
5149	2239488
5150	2239488
5151	1
c	
5200	131072
5201	131072
5202	131072
5203	131072
5204	65536
5205	65536
5206	32768
5207	32768
5208	16384
5209	16384
5210	8192
5211	8192
5212	4096
5213	2048
5214	1024
5215	512

HOLTEC INTERNATIONAL COPYRIGHTED MATERIAL

HI-STORM FSAR
REPORT HI-2002444

Appendix 5.C-47

Rev. 0

5216	256
5217	128
5218	64
5219	32
5220	16
5221	32
5222	64
5223	128
5224	384
5225	192
5226	576
5227	576
5228	1728
5229	1728
5230	5184
5231	5184
5232	15552
5233	15552
5234	31104
5235	31104
5236	31104
5237	62208
5238	62208
5239	62208
5240	62208
5241	124416
5242	124416
5243	373248
5244	373248
5245	1119744
5246	1119744
5247	2239488
5248	2239488
5249	4478976
5250	4478976
5251	1
c	
5300	262144
5301	262144
5302	262144
5303	262144
5304	131072
5305	131072
5306	65536
5307	65536
5308	32768
5309	32768
5310	16384
5311	16384
5312	8192
5313	4096
5314	2048
5315	1024
5316	512
5317	256
5318	128
5319	64
5320	32
5321	64
5322	128
5323	256
5324	768
5325	384
5326	1152
5327	1152

HOLTEC INTERNATIONAL COPYRIGHTED MATERIAL

HI-STORM FSAR
REPORT HI-2002444

Appendix 5.C-48

Rev. 0

5328	3456
5329	3456
5330	10368
5331	10368
5332	31104
5333	31104
5334	62208
5335	62208
5336	62208
5337	124416
5338	124416
5339	124416
5340	124416
5341	248832
5342	248832
5343	746496
5344	746496
5345	2239488
5346	2239488
5347	4478976
5348	4478976
5349	8957952
5350	8957952
5351	1

c

5500	524288
5501	524288
5502	524288
5503	524288
5504	262144
5505	262144
5506	131072
5507	131072
5508	65536
5509	65536
5510	32768
5511	32768
5512	16384
5513	8192
5514	4096
5515	2048
5516	1024
5517	512
5518	256
5519	128
5520	64
5521	128
5522	256
5523	512
5524	1536
5525	768
5526	2304
5527	2304
5528	6912
5529	6912
5530	20736
5531	20736
5532	62208
5533	62208
5534	124416
5535	124416
5536	124416
5537	248832
5538	248832
5539	248832

HOLTEC INTERNATIONAL COPYRIGHTED MATERIAL

HI-STORM FSAR
REPORT HI-2002444

Appendix 5.C-49

Rev. 0

5540	248832
5541	497664
5542	497664
5543	1492992
5544	1492992
5545	4478976
5546	4478976
5547	1
5548	1
5549	1
5550	1
5551	1
c	
5700	1048576
5701	1048576
5702	1048576
5703	1048576
5704	524288
5705	524288
5706	262144
5707	262144
5708	131072
5709	131072
5710	65536
5711	65536
5712	32768
5713	16384
5714	8192
5715	4096
5716	2048
5717	1024
5718	512
5719	256
5720	128
5721	256
5722	512
5723	1024
5724	3072
5725	1536
5726	4608
5727	4608
5728	13824
5729	13824
5730	41472
5731	41472
5732	124416
5733	124416
5734	248832
5735	248832
5736	248832
5737	497664
5738	497664
5739	497664
5740	497664
5741	995328
5742	995328
5743	2985984
5744	2985984
5745	8957952
5746	8957952
c	
5900	2097152
5901	2097152
5902	2097152
5903	2097152

HOLTEC INTERNATIONAL COPYRIGHTED MATERIAL

HI-STORM FSAR
REPORT HI-2002444

Appendix 5.C-50

Rev: 0

5904	1048576
5905	1048576
5906	524288
5907	524288
5908	262144
5909	262144
5910	131072
5911	131072
5912	65536
5913	32768
5914	16384
5915	8192
5916	4096
5917	2048
5918	1024
5919	512
5920	256
5921	512
5922	1024
5923	2048
5924	6144
5925	3072
5926	9216
5927	9216
5928	27648
5929	27648
5930	82944
5931	82944
5932	248832
5933	248832
5934	497664
5935	497664
5936	497664
5937	995328
5938	995328
5939	995328
5940	995328
5941	1990656
5942	1990656
5943	5971968
5944	5971968
5945	17915904
5946	17915904
c	
6100	4194304
6101	4194304
6102	4194304
6103	4194304
6104	2097152
6105	2097152
6106	1048576
6107	1048576
6108	524288
6109	524288
6110	262144
6111	262144
6112	131072
6113	65536
6114	32768
6115	16384
6116	8192
6117	4096
6118	2048
6119	1024
6120	512

HOLTEC INTERNATIONAL COPYRIGHTED MATERIAL

HI-STORM FSAR
REPORT HI-2002444

Appendix 5.C-51

Rev. 0

6121	1024
6122	2048
6123	4096
6124	12288
6125	6144
6126	18432
6127	18432
6128	55296
6129	55296
6130	165888
6131	165888
6132	497664
6133	497664
6134	995328
6135	995328
6136	995328
6137	1990656
6138	1990656
6139	1990656
6140	1990656
6141	3981312
6142	3981312
6143	11943936
6144	11943936
6145	35831808
6146	35831808
c	
6300	8388608
6301	8388608
6302	8388608
6303	8388608
6304	4194304
6305	4194304
6306	2097152
6307	2097152
6308	1048576
6309	1048576
6310	524288
6311	524288
6312	262144
6313	131072
6314	65536
6315	32768
6316	16384
6317	8192
6318	4096
6319	2048
6320	1024
6321	2048
6322	4096
6323	8192
6324	24576
6325	12288
6326	36864
6327	36864
6328	110592
6329	110592
6330	331776
6331	331776
6332	995328
6333	995328
6334	1990656
6335	1990656
6336	1990656
6337	3981312

HOLTEC INTERNATIONAL COPYRIGHTED MATERIAL

HI-STORM FSAR
REPORT HI-2002444

Appendix 5.C-52

Rev. 0

6338	3981312
6339	3981312
6340	3981312
6341	7962624
6342	7962624
6343	23887872
6344	23887872
6345	71663616
6346	71663616
c	
6400	8388608
6401	8388608
6402	8388608
6403	8388608
6404	4194304
6405	4194304
6406	2097152
6407	2097152
6408	1048576
6409	1048576
6410	524288
6411	524288
6412	262144
6413	131072
6414	65536
6415	32768
6416	16384
6417	8192
6418	4096
6419	2048
6420	1024
6421	2048
6422	4096
6423	8192
6424	24576
6425	12288
6426	36864
6427	36864
6428	110592
6429	110592
6430	331776
6431	331776
6432	995328
6433	995328
6434	1990656
6435	1990656
6436	1990656
6437	3981312
6438	3981312
6439	3981312
6440	3981312
6441	7962624
6442	7962624
6443	23887872
6444	23887872
6445	71663616
6446	71663616
c	
6500	16777216
6501	16777216
6502	16777216
6503	16777216
6504	8388608
6505	8388608
6506	4194304

HOLTEC INTERNATIONAL COPYRIGHTED MATERIAL

HI-STORM FSAR
REPORT HI-2002444

Appendix 5.C-53

Rev. 0

6507	4194304
6508	2097152
6509	2097152
6510	1048576
6511	1048576
6512	524288
6513	262144
6514	131072
6515	65536
6516	32768
6517	16384
6518	8192
6519	4096
6520	2048
6521	4096
6522	8192
6523	16384
6524	49152
6525	24576
6526	73728
6527	73728
6528	221184
6529	221184
6530	663552
6531	663552
6532	1990656
6533	1990656
6534	3981312
6535	3981312
6536	3981312
6537	7962624
6538	7962624
6539	7962624
6540	7962624
6541	15925248
6542	15925248
6543	47775744
6544	47775744
6545	143327232
6546	143327232

c

6601	1
6602	1
6603	1
6604	1
6605	1
6606	1
6607	1
6608	1
6609	1
6610	1
6611	1
6612	1
6613	1
6614	1
6615	1
6616	1
6617	1
6618	1
6619	1
6620	1
6621	1
6622	1
6623	1
6624	1

HOLTEC INTERNATIONAL COPYRIGHTED MATERIAL

HI-STORM FSAR
REPORT HI-2002444

Appendix 5.C-54

Rev. 0

6625 1
6626 1
6627 1
6628 1
6629 1
6630 1
6631 1
6632 1
6633 1
6634 1
6635 1
6636 1
6637 1
6638 1
6639 1
6640 1
6641 1
6642 1
6643 1
6644 1
6645 1
6646 1
6647 1
6648 1
6649 1
6650 1
6651 1

c

c

301 1
302 1
303 1
304 1
305 1
306 1
307 1
308 1
309 1
310 1
311 1
312 1
313 1
338 1
339 1
340 1
341 1
342 1
343 1
344 1
345 1
350 1
352 1
354 1
359 1
392 1
393 1
394 1
395 1
401 1
402 1
403 1
404 1
405 1
406 1
407 1

HOLTEC INTERNATIONAL COPYRIGHTED MATERIAL

HI-STORM FSAR
REPORT HI-2002444

Appendix 5.C-55

Rev. 0

408 1
409 1
410 1
411 1
412 1
413 1
438 1
439 1
440 1
441 1
442 1
443 1
444 1
445 1
450 1
452 1
454 1
459 1
492 1
493 1
494 1
495 1
501 1
502 1
503 1
504 1
505 1
506 1
507 1
508 1
509 1
510 1
511 1
512 1
513 1
538 1
539 1
540 1
541 1
542 1
543 1
544 1
545 1
550 1
552 1
554 1
559 1
592 1
593 1
594 1
595 1
601 1
602 1
603 1
604 1
605 1
606 1
607 1
608 1
609 1
610 1
611 1
612 1
613 1
638 1

HOLTEC INTERNATIONAL COPYRIGHTED MATERIAL

HI-STORM FSAR
REPORT HI-2002444

Appendix 5.C-56

Rev. 0

639 1
640 1
641 1
642 1
643 1
644 1
645 1
650 1
652 1
654 1
659 1
692 1
693 1
694 1
695 1
701 1
702 1
703 1
704 1
705 1
706 1
707 1
708 1
709 1
710 1
711 1
712 1
713 1
738 1
739 1
740 1
741 1
742 1
743 1
744 1
745 1
750 1
752 1
754 1
759 1
792 1
793 1
794 1
795 1
202 1
203 1
205 1
206 1
101 1
102 1
207 1
208 1
210 1
103 1
104 1
105 1
106 1
211 1
213 1
107 1
108 1
109 1
110 1
111 1
112 1

HOLTEC INTERNATIONAL COPYRIGHTED MATERIAL

HI-STORM FSAR
REPORT HI-2002444

Appendix 5.C-57

Rev. 0

214 1
215 1
113 1
114 1
115 1
116 1
117 1
118 1
216 1
218 1
119 1
120 1
121 1
122 1
219 1
221 1
222 1
123 1
124 1
223 1
224 1
226 1
227 1
10001 1
10002 1
10003 1
10004 1
10005 1
10006 1
10007 1
10008 1
10009 1
10010 1
10011 1
10012 1
10013 1
10101 1
10102 1
10103 1
10104 1
10105 1
10106 1
10107 1
10108 1
10109 1
10110 1
10111 1
10112 1
10113 1
10114 1
10121 1
10122 1
10131 1
10132 1
10133 1
10134 1
10135 1
10136 1
10137 1
10138 1
10141 1
10142 1
10143 1
10144 1
10145 1

HOLTEC INTERNATIONAL COPYRIGHTED MATERIAL

HI-STORM FSAR
REPORT HI-2002444

Appendix 5.C-58

Rev. 0

10146 1
11146 1
10147 1
10148 1
11148 1
10149 1
10150 1
10151 1
10152 1
10153 1
10154 1
10155 1
10156 1
10157 1
10158 1
10159 1
10160 1
10161 1
10162 1
10163 1
10164 1
10165 1
10166 1
10167 1
10168 1
10169 1
10170 1
10243 1
10244 1
10245 1
10246 1
10247 1
10248 1
10249 1
10250 1
10251 1
10252 1
10253 1
10254 1
10255 1
10256 1
10257 1
10258 1
10259 1
10260 1
10261 1
10262 1
10263 1
10264 1
10265 1
10266 1
10267 1
10268 1
10269 1
10270 1
10301 1
10302 1
10303 1
10304 1
10305 1
10306 1
10307 1
10308 1
11302 1
11303 1

HOLTEC INTERNATIONAL COPYRIGHTED MATERIAL

HI-STORM FSAR
REPORT HI-2002444

Appendix 5:C-59

Rev. 0

11304 1
11305 1
11306 1
11307 1
11308 1
13303 1
13304 1
13305 1
13306 1
13307 1
13308 1
12301 1
12302 1
12303 1
12304 1
12305 1
12306 1
12307 1
12308 1
10309 1
10310 1
10311 1
10312 1
10313 1
10314 1
10407 1
10408 1
10409 1
10410 1
10411 1
10412 1
10413 1
10414 1
10421 1
10422 1
10431 1
10432 1
10433 1
10434 1
10435 1
10436 1
10437 1
10438 1
10441 1
10442 1
10443 1
10444 1
10445 1
10446 1
10447 1
10448 1
10449 1
10450 1
10451 1
10452 1
10453 1
10454 1
10455 1
10456 1
10457 1
10458 1
10459 1
10470 1
10543 1
10544 1

HOLTEC INTERNATIONAL COPYRIGHTED MATERIAL

HI-STORM FSAR
REPORT HI-2002444

Appendix 5.C-60

Rev. 0

APPENDIX 5.D

DOSE RATE COMPARISON FOR DIFFERENT COBALT IMPURITY LEVELS

HOLTEC INTERNATIONAL COPYRIGHTED MATERIAL

HI-STORM FSAR
REPORT HI-2002444

Appendix 5.D-1

Rev. 1

HI-STORM-100 FSAR, NON-PROPRIETARY
REVISION 12
MARCH 12, 2014

The dose rate adjacent to and one meter from the 100-ton HI-TRAC and the HI-STORM overpack are presented on Tables 5.D.1 through 5.D.4 for the MPC-24 with different burnup and cooling times and different assumed Cobalt-59 impurity levels for inconel. The HI-TRAC results were calculated for an earlier design which utilized 30 steel fins 0.375 inches thick compared to 10 steel fins 1.25 inches thick. The change in rib design only affects the magnitude of the dose rates presented for the radial surface but does not affect the conclusions discussed below. The following burnup and cooling time combinations are presented.

100-ton HI-TRAC

- 35,000 MWD/MTU and 5 year cooling
1000 ppm (1.0 gm/kg) Cobalt-59 impurity in inconel
- 45,000 MWD/MTU and 9 year cooling
4700 ppm (4.7 gm/kg) Cobalt-59 impurity in inconel

HI-STORM

- 45,000 MWD/MTU and 5 year cooling
1000 ppm (1.0 gm/kg) Cobalt-59 impurity in inconel
- 45,000 MWD/MTU and 9 year cooling
4700 ppm (4.7 gm/kg) Cobalt-59 impurity in inconel

On Tables 5.D.1 through 5.D.4, the contribution to the dose rate from activation in incore grid spacers is explicitly shown.

These results demonstrate that the dose rates at the longer cooling time are essentially equivalent to (within 11%) or bounded by the dose rates at the shorter cooling times even though a very conservative Cobalt-59 impurity level of 4700 ppm was assumed for the longer cooling times.

Table 5.2.1 shows the masses of inconel and steel that are used in the modeling of the PWR fuel assembly. When 4700 ppm was used for the impurity level in the inconel, an effective Cobalt-59 impurity level was used for the regions containing both steel and inconel. The following table summarizes the impurity levels that were used.

Region	Regional Co-59 impurity when 1000 ppm in inconel assumed	Regional Co-59 impurity when 4700 ppm in inconel assumed
Lower end fitting	1000 ppm	1340 ppm
Incore grid spacers	1000 ppm	4700 ppm
Gas plenum springs	1000 ppm	3417 ppm
Gas plenum spacer	1000 ppm	3417 ppm
Upper end fitting	1000 ppm	1000 ppm

Table 5.D.1

DOSE RATES ADJACENT TO 100-TON HI-TRAC FOR NORMAL CONDITIONS
MPC-24 DESIGN BASIS ZIRCALOY CLAD FUEL

Dose Point † Location	Incore Grid Spacer ⁶⁰ Co Gammas (mrem/hr)	Fuel Gammas (mrem/hr)	(n,γ) Gammas (mrem/hr)	⁶⁰ Co Gammas (mrem/hr)	Neutrons (mrem/hr)	Totals (mrem/hr)
4700 ppm Co-59 in inconel						
45,000 MWD/MTU AND 9-YEAR COOLING						
1	12.20	11.89	12.65	507.16	171.98	715.87
2	345.15	332.90	52.81	0.75	88.26	819.87
3	4.72	5.19	1.98	369.24	214.70	595.83
4	7.13	8.11	0.97	197.76	180.55	394.52
5 (pool lid)	48.63	54.68	17.52	2557.68	1194.17	3872.68
5 (transfer lid)	137.52	155.17	0.97	3811.45	674.42	4779.53
1000 ppm Co-59 in inconel						
35,000 MWD/MTU AND 5-YEAR COOLING						
1	3.73	27.05	6.51	543.06	88.57	668.92
2	105.37	696.56	27.19	0.80	45.46	875.38
3	1.44	11.44	1.02	473.51	110.57	597.98
4	2.18	17.87	0.50	241.22	92.97	354.74
5 (pool lid)	28.09	186.49	8.27	2751.19	554.51	3528.55
5 (transfer lid)	41.98	293.57	0.50	4081.28	347.33	4764.66

† Refer to Figure 5.1.4.

Table 5.D.2

DOSE RATES AT 1 METER FROM 100-TON HI-TRAC FOR NORMAL CONDITIONS
MPC-24 DESIGN BASIS ZIRCALOY CLAD FUEL

Dose Point † Location	Incore Grid Spacer ⁶⁰ Co Gammas (mrem/hr)	Fuel Gammas (mrem/hr)	(n,γ) Gammas (mrem/hr)	⁶⁰ Co Gammas (mrem/hr)	Neutrons (mrem/hr)	Totals (mrem/hr)
4700 ppm Co-59 in inconel						
45,000 MWD/MTU AND 9-YEAR COOLING						
1	44.32	43.03	7.14	73.99	27.98	196.46
2	148.49	143.94	16.40	6.18	32.38	347.39
3	18.76	18.25	3.88	72.75	13.83	127.47
4	2.19	2.80	0.17	61.70	44.87	111.73
5(transfer lid)	55.57	64.25	0.18	1556.99	188.18	1865.16
1000 ppm Co-59 in inconel						
35,000 MWD/MTU AND 5-YEAR COOLING						
1	13.53	91.20	3.68	79.16	14.41	201.97
2	45.33	302.99	8.44	6.13	16.68	379.57
3	5.73	38.74	2.00	71.95	7.12	125.54
4	0.67	6.21	0.09	74.47	23.11	104.55
5(transfer lid)	16.96	128.14	0.09	1667.22	96.91	1909.32

† Refer to Figure 5.1.4.

Table 5.D.3

DOSE RATES ADJACENT TO HI-STORM OVERPACK FOR NORMAL CONDITIONS
MPC-24 DESIGN BASIS ZIRCALOY CLAD FUEL

Dose Point † Location	Incore Grid Spacer ⁶⁰ Co Gammas (mrem/hr)	Fuel Gammas †† (mrem/hr)	⁶⁰ Co Gammas (mrem/hr)	Neutrons (mrem/hr)	Totals (mrem/hr)
4700 ppm Co-59 in inonel					
45,000 MWD/MTU AND 9-YEAR COOLING					
1	0.54	2.95	3.86	2.37	9.72
2	7.73	10.40	0.03	1.48	19.63
3	0.36	1.97	2.59	1.18	6.11
4	0.10	0.53	0.33	3.10	4.06
1000 ppm Co-59 in inonel					
45,000 MWD/MTU AND 5-YEAR COOLING					
1	0.20	5.68	4.87	2.76	13.51
2	2.73	28.93	0.03	1.88	33.58
3	3.87	0.13	3.21	1.38	8.59
4	0.04	0.91	0.36	3.60	4.91

† Refer to Figures 5.1.1.

†† Gammas generated by neutron capture are included with fuel gammas.

Table 5.D.4

DOSE RATES ONE METER FROM HI-STORM OVERPACK FOR NORMAL CONDITIONS
MPC-24 DESIGN BASIS ZIRCALOY CLAD FUEL

Dose Point † Location	Incore Grid Spacer ⁶⁰ Co Gammas (mrem/hr)	Fuel Gammas †† (mrem/hr)	⁶⁰ Co Gammas (mrem/hr)	Neutrons (mrem/hr)	Totals (mrem/hr)
4700 ppm Co-59 in inconel					
45,000 MWD/MTU AND 9-YEAR COOLING					
1	0.77	2.01	2.30	0.46	5.54
2	3.90	5.14	0.39	0.64	10.08
3	0.44	1.09	1.72	0.18	3.42
4	0.05	0.23	0.14	0.94	1.37
1000 ppm Co-59 in inconel					
45,000 MWD/MTU AND 5-YEAR COOLING					
1	0.28	4.49	2.90	0.54	8.21
2	1.41	14.98	0.25	0.78	17.42
3	0.16	2.57	2.09	0.21	5.03
4	0.02	0.42	0.16	1.10	1.70

† Refer to Figures 5.1.1.

†† Gammas generated by neutron capture are included with fuel gammas.

APPENDIX 5.E

DELETED

HOLTEC INTERNATIONAL COPYRIGHTED MATERIAL

HI-STORM FSAR
REPORT HI-2002444

Appendix 5.E-1

Rev. 7

HI-STORM 100 FSAR, NON-PROPRIETARY
REVISION 12
MARCH 12, 2014

APPENDIX 5.F

Additional Information on the Burnup Versus Decay Heat and Enrichment Equation

HOLTEC INTERNATIONAL COPYRIGHTED MATERIAL

HI-STORM FSAR
REPORT HI-2002444

Appendix 5.F-1

Rev. 3

HI-STORM 100 FSAR, NON-PROPRIETARY
REVISION 12
MARCH 12, 2014

The equation in Section 5.2.5.3 was determined to be the best equation capable of reproducing the burnup versus enrichment and decay heat data calculated with ORIGEN-S. As an example, Figure 5.F.1 graphically presents ORIGEN-S burnup versus decay heat data for various enrichments for the 9x9C/D fuel assembly array/classes with a 20- year cooling time. This data could also be represented graphically as a surface on a three dimensional plot. However, the 2D plot is easier to visualize. Additional enrichments were used in the ORIGEN-S calculations and have been omitted for clarity.

Figures 5.F.2 through 5.F.4 show ORIGEN-S burnup versus decay heat data for specific enrichments. In addition to the ORIGEN-S data, these figures present the results of the original curve fit and the adjusted curve fit. Table 5.F.1 below shows the equation coefficients used for both curve fits. As these figures indicate, the curve fit faithfully reproduces the ORIGEN-S data.

Figure 5.F.5 provides a different representation of the curve fit versus ORIGEN-S comparison. This figure was generated by taking the ORIGEN-S enrichment and decay heat data from Figure 5.F.1 for a constant burnup of 30,000 MWD/MTU and calculating the burnup using the fitted equation with coefficients from Table 5.F.1. The resulting burnup versus enrichment is plotted. Table 5.F.2 presents the ORIGEN-S and curve fit data in tabular form used to generate Figure 5.F.5. Since the ORIGEN-S calculations were performed for a specific burnup of 30,000 MWD/MTU, the ORIGEN-S data is represented as a straight line. Figures 5.F.6 and 5.F.7 provide the same representation for burnups of 45,000 and 65,000 MWD/MTU. These results also indicate that the non-adjusted curve fit provides a very good representation of the ORIGEN-S data. It is also clear that the adjusted curve fit always bounds the ORIGEN-S data by predicting a lower burnup which results in a more restrictive and conservative limit for the user.

Table 5.F.1

COEFFICIENTS FOR EQUATION IN SECTION 5.2.5.3 FOR THE 9X9C/D FUEL ASSEMBLY ARRAY/CLASSES WITH A COOLING TIME OF 20 YEARS

Coefficient	Original Curve Fit	Adjusted Curve Fit
A	249944	249944
B	-382059	-382059
C	308281	308281
D	-205.495	-205.495
E	9362.63	9362.63
F	1389.71	1389.71
G	-1995.54	-2350.49

HOLTEC INTERNATIONAL COPYRIGHTED MATERIAL

HI-STORM FSAR
REPORT HI-2002444

Appendix 5.F-3

Rev. 3

Table 5.F.2

ORIGEN-S AND CURVE FIT DATA FOR THE 9X9C/D FUEL ASSEMBLY
 ARRAY/CLASSES
 WITH A COOLING TIME OF 20 YEARS

Specified Enrichment	ORIGEN-S calculated decay heat per assembly (kw)	ORIGEN-S calculated burnup (MWD/MTU)	Burnup calculated with original curve fit (MWD/MTU)	Burnup calculated with adjusted curve fit (MWD/MTU)
0.7	1.55E-01	30000	29700.69	29345.74
1	1.53E-01	30000	29715.24	29360.29
1.35	1.52E-01	30000	29759.8	29404.85
1.7	1.50E-01	30000	29849.09	29494.14
2	1.50E-01	30000	29997.43	29642.48
2.3	1.49E-01	30000	30050.56	29695.61
2.6	1.49E-01	30000	30120.16	29765.21
2.9	1.49E-01	30000	30228.56	29873.61
3.2	1.50E-01	30000	30340.01	29985.06
3.4	1.50E-01	30000	30354.95	30000
3.6	1.49E-01	30000	30172.21	29817.26
3.9	1.48E-01	30000	30095.41	29740.46
4.2	1.48E-01	30000	30001.17	29646.22
4.5	1.48E-01	30000	29890.42	29535.47
4.8	1.48E-01	30000	29764.09	29409.14
5	1.49E-01	30000	29731.66	29376.71

HOLTEC INTERNATIONAL COPYRIGHTED MATERIAL

HI-STORM FSAR
 REPORT HI-2002444

Appendix 5.F-4

Rev. 3

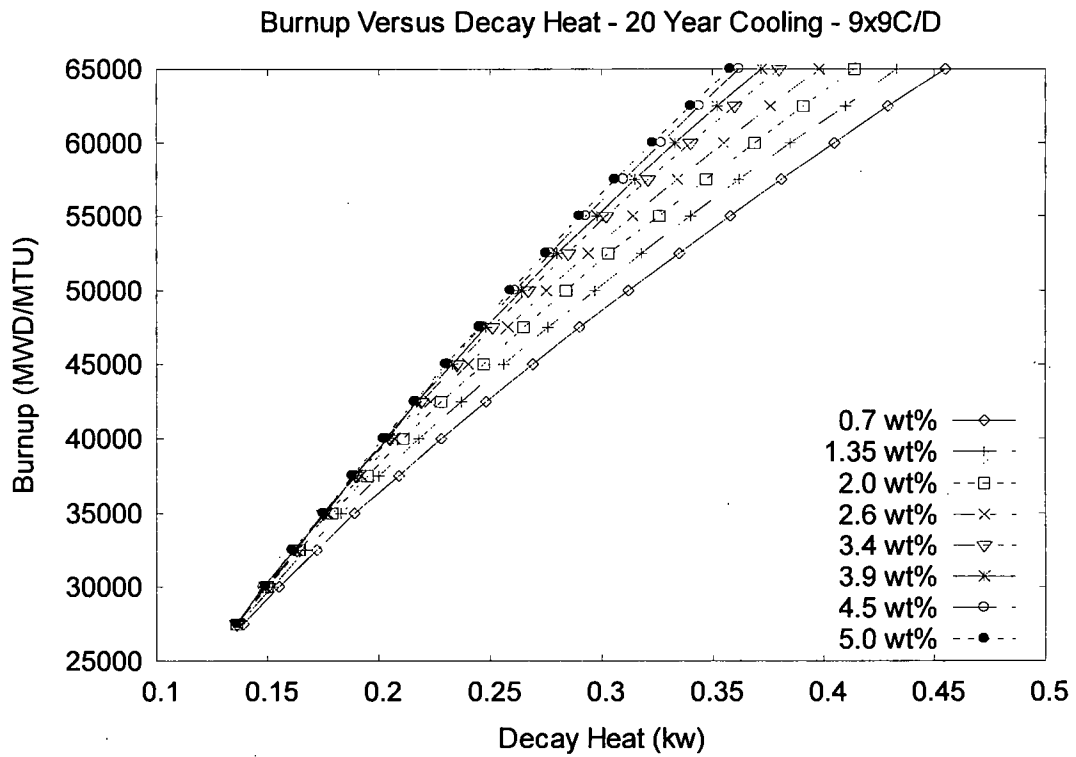


FIGURE 5.F.1; ORIGEN-S CALCULATED BURNUP VERSUS DECAY HEAT FOR VARIOUS ENRICHMENTS

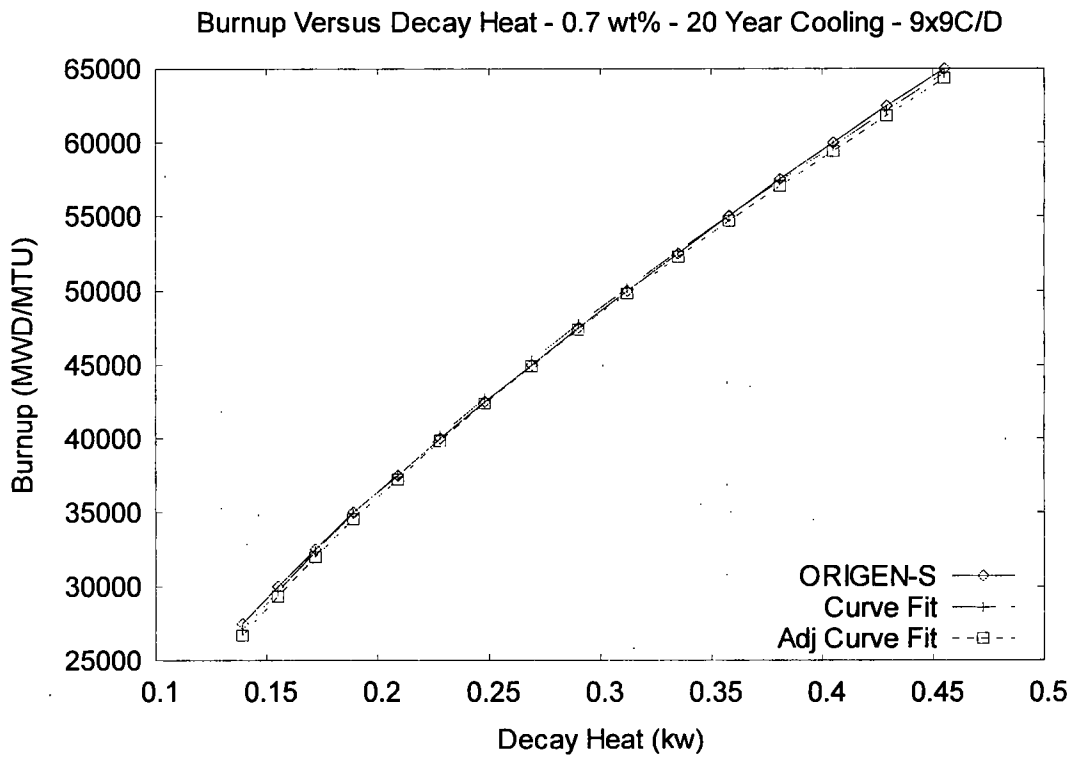


FIGURE 5.F.2; A COMPARISON OF THE BURNUP VERSUS DECAY HEAT CALCULATIONS FROM ORIGIN-S, THE ORIGINAL CURVE FIT, AND THE ADJUSTED CURVE FIT FOR AN ENRICHMENT OF 0.7 WT.% ²³⁵U.

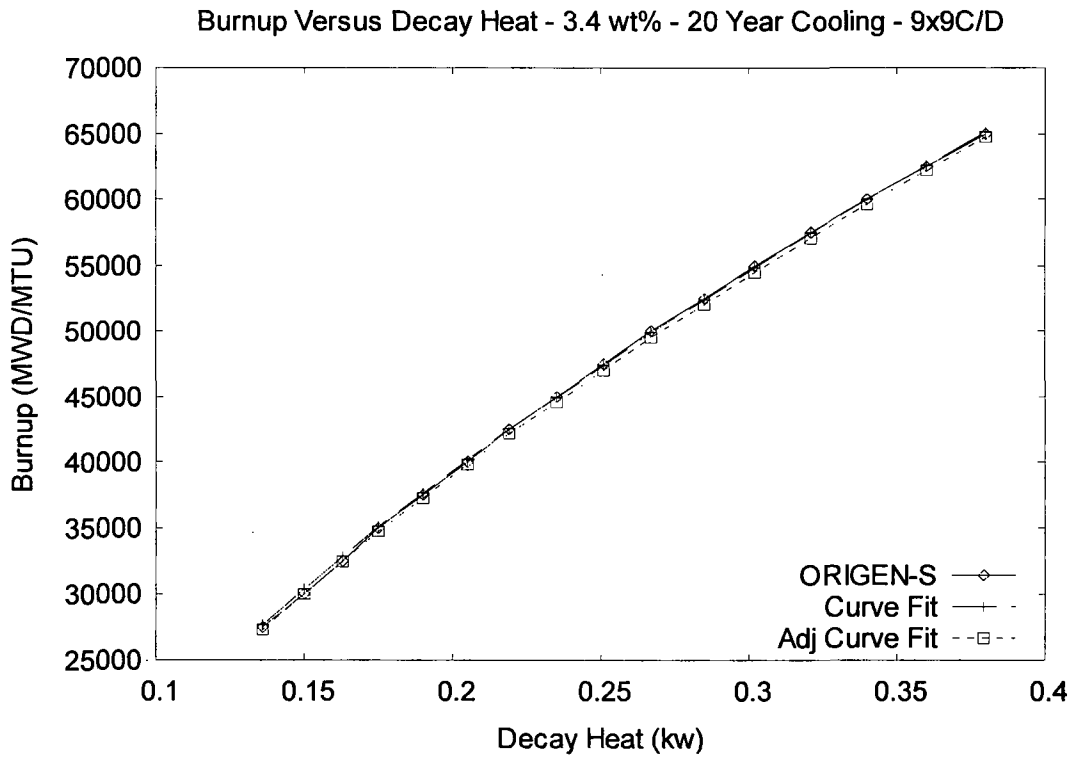


FIGURE 5.F.3; A COMPARISON OF THE BURNUP VERSUS DECAY HEAT CALCULATIONS FROM ORIGEN-S, THE ORIGINAL CURVE FIT, AND THE ADJUSTED CURVE FIT FOR AN ENRICHMENT OF 3.4 WT.% ²³⁵U.

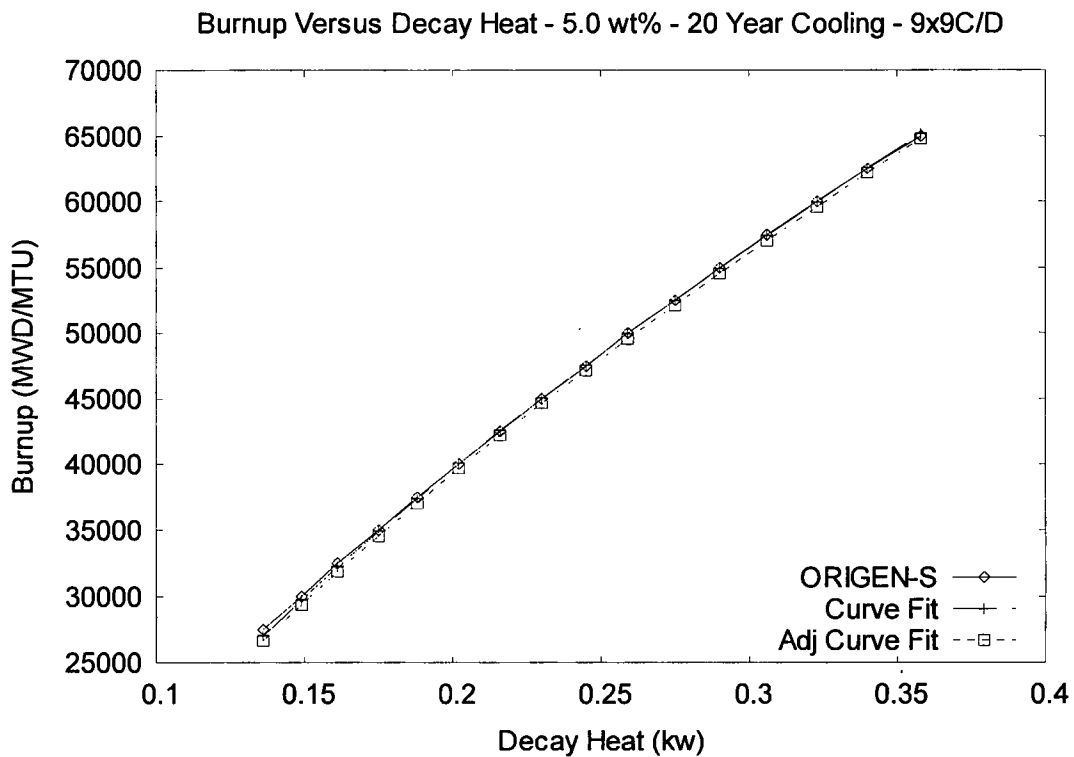


FIGURE 5.F.4; A COMPARISON OF THE BURNUP VERSUS DECAY HEAT CALCULATIONS FROM ORIGEN-S, THE ORIGINAL CURVE FIT, AND THE ADJUSTED CURVE FIT FOR AN ENRICHMENT OF 5.0 WT.% ²³⁵U.

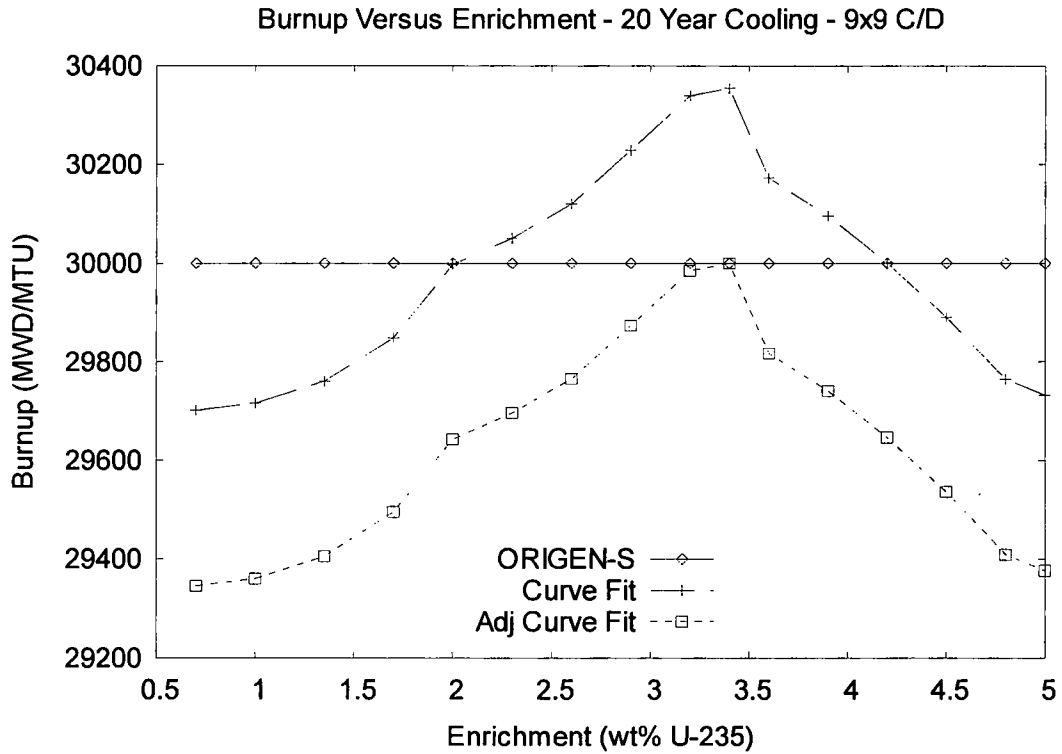


FIGURE 5.F.5; A COMPARISON OF THE CALCULATED BURNUPS USING THE CURVE FIT AND THE ADJUSTED CURVE FIT FOR VARIOUS ENRICHMENTS. ALL ORIGEN-S CALCULATIONS YIELDED A BURNUP OF 30,000 MWD/MTU.

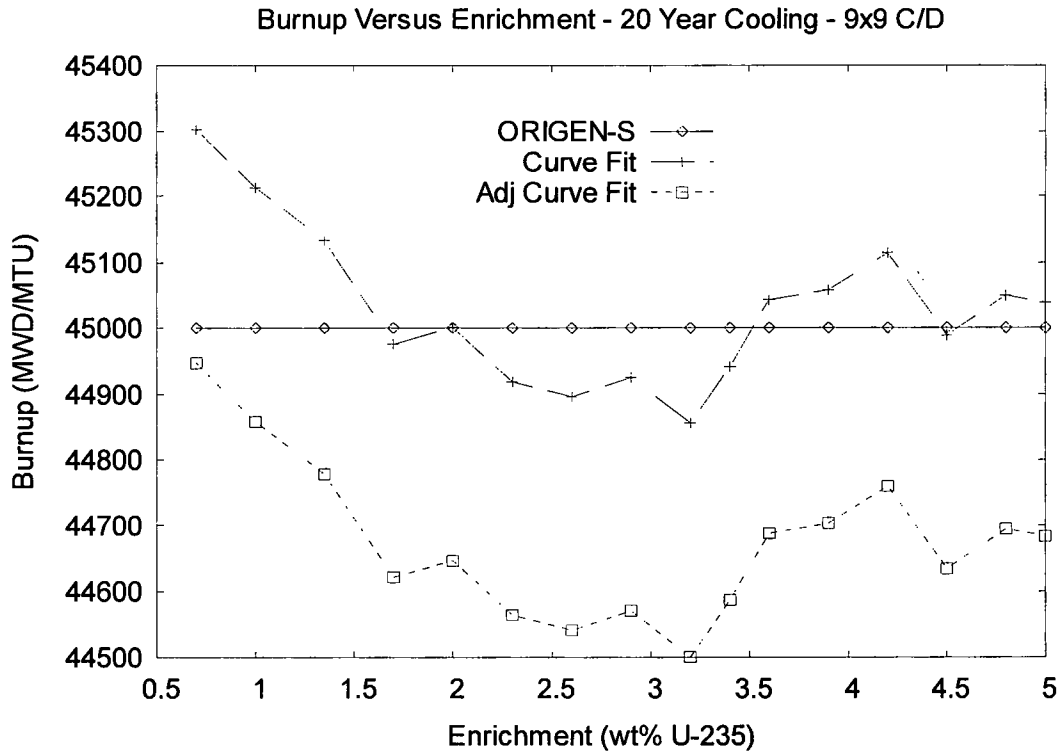


FIGURE 5.F.6; A COMPARISON OF THE CALCULATED BURNUPS USING THE CURVE FIT AND THE ADJUSTED CURVE FIT FOR VARIOUS ENRICHMENTS. ALL ORIGEN-S CALCULATIONS YIELDED A BURNUP OF 45,000 MWD/MTU.

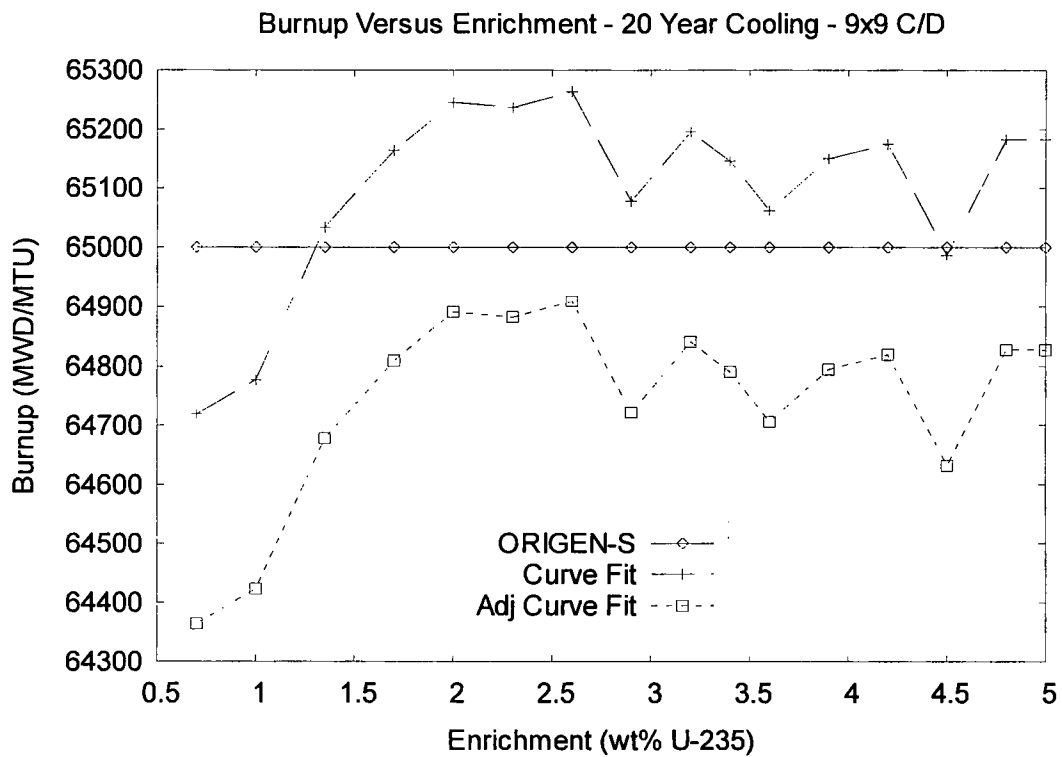


FIGURE 5.F.7; A COMPARISON OF THE CALCULATED BURNUPS USING THE CURVE FIT AND THE ADJUSTED CURVE FIT FOR VARIOUS ENRICHMENTS. ALL ORIGEN-S CALCULATIONS YIELDED A BURNUP OF 65,000 MWD/MTU.

SUPPLEMENT 5.I

SHIELDING EVALUATION OF THE HI-STORM 100U SYSTEM

5.1.0 INTRODUCTION

This supplement is focused on providing a shielding evaluation of the HI-STORM 100U system pursuant to the guidelines in NUREG-1536. The evaluation presented herein supplements those evaluations of the HI-STORM overpacks contained in the main body of Chapter 5 of this FSAR, and information in the main body of Chapter 5 that remains applicable to the HI-STORM 100U is not repeated in this supplement. To aid the reader, the sections in this supplement are numbered in the same fashion as the corresponding sections in the main body of this chapter, i.e., Sections 5.1.1 through 5.1.6 correspond to Sections 5.1 through 5.6. Tables and figures in this supplement are labeled sequentially.

5.1.1 DISCUSSION AND RESULTS

The HI-STORM 100U system differs from the HI-STORM system evaluated in the main body of this chapter only in the use of a different storage overpack, the HI-STORM 100U vertical ventilated module (VVM). All MPCs and HI-TRAC transfer casks are identical between the systems. All calculations, results and conclusions regarding the HI-TRAC transfer cask presented in the main body of Chapter 5 are therefore directly applicable to the HI-STORM 100U system, and no further calculations for the HI-TRAC transfer cask are presented in this supplement.

The shielding design of the HI-STORM 100U VVM is similar to the overpack designs evaluated in the main body of this chapter, with gamma shielding provided by the concrete and the steel of the module, and neutron shielding provided by the module concrete. However, the VVM is mostly located below the surface of the surrounding soil. This results in additional shielding, and a significant reduction in the directly accessible surface for the VVM compared to the other overpacks. Dose rates from a HI-STORM 100U VVM at the site boundary are therefore significantly lower than, and bounded by, dose rates from the above ground HI-STORM systems evaluated in the main body of this chapter.

Shielding analyses were performed for the HI-STORM 100U with an MPC-32 loaded with intact design basis zircaloy clad fuel assemblies. As discussed in Section 5.1, three burnup and cooling time combinations are analyzed for the MPC-32, namely 45,000 MWD/MTU and 3 years, 60,000 MWD/MTU and 4 years, and 69,000 MWD/MTU and 5 years cooling time. These burnup and cooling time combinations bound all assemblies permitted to be loaded in any of the uniform or regionalized loading configurations in the MPC-32. All calculations for the HI-STORM 100 are performed for all three combinations, and the results corresponding to the highest total dose rate at each dose location are reported. Dose rates at some locations are more dominated by the contribution from the neutron source. In this case, the highest burnup will result in the highest dose rates. At other locations, dose rates are more dominated by the

HOLTEC INTERNATIONAL COPYRIGHTED MATERIAL

contribution from the photon source terms. In this case, the shortest cooling time will result in the highest dose rates. In the result table, the burnup and cooling time combination that leads to the highest dose rate is indicated for each dose location. It should further be noted that while the number and location of assemblies with such burnup and cooling time combinations would be restricted for any actually loaded cask, it was assumed in the shielding evaluations presented here that all assemblies have the same characteristics. To indicate the level of conservatism in this approach, note that the burnup and cooling time combinations evaluated here correspond to a heat load of about 2.2 kW per assembly, or about 70 kW for the entire MPC-32. This is an important fact in respect to the choice to perform analyses for the MPC-32, and not for the other MPCs. While **calculated** dose rates for the other baskets could potentially be slightly higher than those for the MPC-32, based on the differences in the MPC design, fuel type, and burnup and cooling times, it is not expected that actual dose rates for any MPC would exceed those calculated here for the MPC-32. This justifies restricting the analyses here to the MPC-32. Table 5.I.1 presents the results for those burnup and cooling time combinations out of those listed above that resulted in the maximum dose rates at each location. Figure 5.I.1 identifies the locations of the dose points referenced in the table. Dose Points #1 and #2 are the locations of the inlet and outlet vents, respectively. The dose values reported adjacent to these dose points were averaged over the vent opening while the dose values reported at 1 meter from these dose locations were taken at the mid-plane of the vent. Dose Point #3, which is positioned approximately over the air flow annulus, is the location of the highest dose rate on the lid in the final storage configuration. Dose Point # 4 is averaged over the vertical air flow passage shown in Figure 5.I.1. Dose Point #4, adjacent to the overpack, is not accessible in the final storage configuration as depicted in Figure 5.I.1. Dose Point #5 is located over a tube that would be required for the ICCPS test station. Dose Point #6 is located over an empty VVM located adjacent to a loaded VVM. Except for conditions during construction discussed further below, calculations were only performed for normal conditions, since Subsections 5.1.1 and 5.1.2 concluded that off-normal and accident conditions for the HI-STORM overpack are identical or equivalent to normal conditions for the purpose of the shielding evaluation.

The tube for the ICCPS test station is modeled as a cylindrical hole that extends from the VIP down to the base plate of the MPC. The tube is modeled with a diameter of 4 inches, located about 5.5 feet from the center of the VVM. If the actual tube has characteristics that could result in higher dose rates, i.e. is larger or closer to the VVM than modeled here, the actual tube characteristics should be considered in the site specific dose calculations. Depending on the results of those calculations, additional measures, such as added shielding at the top of the tube, may be required.

A comparison between the dose rates in Table 5.I.1 and dose rates presented in Tables 5.1.11 and 5.1.14 of the main body of this chapter show that the maximum dose rate for the HI-STORM 100U module with an MPC-32 is well below the maximum dose rate for the HI-STORM 100S Version B with an MPC-32. Furthermore, the area associated with the maximum dose rate for the HI-STORM 100U module is the inlet vent. This area is much smaller than the area associated with the maximum dose rate for the overpack analyzed in the main part of this chapter, which is the outer radial surface of the overpack. It can therefore be concluded that the HI-STORM 100U

HOLTEC INTERNATIONAL COPYRIGHTED MATERIAL

is bounded by the HI-STORM 100 systems analyzed in the main body of this chapter, since the HI-STORM 100U has a smaller directly accessible surface, lower maximum dose rates and smaller areas associated with these maximum dose rates. Nevertheless, calculations were performed to determine the dose rate from the HI-STORM 100U at a distance of 100 meters from the inlet vent. These results, which are presented in Table 5.I.2, indicate that the HI-STORM 100U easily meets the requirements of 10CFR72.104 at 100 meters. Comparing these results to the results in Table 5.4.7 demonstrates that the off-site dose from the HI-STORM 100U is a very small fraction of the off-site dose from an above ground overpack.

ISFSIs with HI-STORM 100U VVMs might be built in one stage or in several stages. If the ISFSI is built in several stages, then excavation work will be necessary in the vicinity of the section of the ISFSI that is already in operation and contains loaded modules. To protect workers from radiation from the loaded modules, a radiation protection space (RPS) boundary is defined around the ISFSI in the drawing in Section 1.I.5. The RPS boundary is placed so that in a radial direction, a minimum of 10.5 ft of engineered fill remains between the construction site and the closest loaded module. For a loaded module on the periphery of the ISFSI, this places the boundary 14 ft from the center of the module (10.5 ft + radius of the VVM of 3.5 ft). For a loaded module not on the periphery of the ISFSI, this places the boundary 21 feet from the center of the module (10.5 ft + diameter of the outer empty VVM of 7 ft + radius of the loaded VVM of 3.5 ft). Calculations during excavations were performed for both normal and accident conditions. Under normal conditions, calculations were conservatively performed with the 6.5 ft remaining fill around a loaded VVM instead of the 10.5 ft required by the RPS. The calculations result in a maximum dose rate of only about 0.2 mrem/hr at the surface of the excavation. This dose rate is very low, specifically lower than the dose rates at 1 m from the inlet vents of the modules. The dose rates at a construction site might therefore be dominated by the direct dose rates from the inlet vents, and depending on the loading condition of the operating part of the ISFSI, temporary shielding might be used to reduce dose rates to the construction site. Note that the dose rate of 0.2 mrem/hr is calculated using soil with a density of 1.7 g/cm³ for the 6.5 ft layer. This is conservative since the material in and around the VVM modules would be engineered fill which has a typical density of more than 1.7 g/cm³. The bounding accident condition is identified in Supplement 3.I, Section 3.I.4.8.2 to be the impact of a tornado missile with a diameter of 8 inches. This missile would penetrate the soil about 10 ft, and this case was used as the basis for selecting the size of the RPS. This is the bounding condition since smaller missiles have less energy, and larger missiles (automotive) have a much larger impact area thus resulting in a much smaller indentation of the soil. Under the bounding condition, the maximum dose over a period of 30 days at a distance of 100 m from the VVM would be 1.4 rem. This is less than the limit in 10CFR72, and also less than the dose for the bounding accident condition discussed in the main body of Chapter 5.

Finally, as observed in Section 1.I.2, the HI-STORM 100U VVM is deliberately engineered to permit the MPC cavity to be deepened such that the MPC is located deeper inside the module. The elevation of the MPC shown in the drawings in Section 1.5 and analyzed in this supplement is the highest permitted elevation. Of course, lowering the MPC in the VVM would further reduce the radiation dose rates below those computed herein.

HOLTEC INTERNATIONAL COPYRIGHTED MATERIAL

5.1.2 SOURCE SPECIFICATION

The analyses in this supplement are performed for intact design basis zircaloy clad fuel assemblies as described in Section 5.2.

5.1.3 MODEL SPECIFICATIONS

The shielding analyses of the HI-STORM 100U module are performed with MCNP-4A, which is the same code used for the analyses presented in the main body of this chapter.

Section 1.1.5 provides the drawings that describe the HI-STORM 100U System. These drawings, using nominal dimensions, were used to create the MCNP models used in the radiation transport calculations. Modeling deviations from these drawings are discussed below. Figure 5.1.2 shows cross sectional views of the HI-STORM 100U module as it was modeled in MCNP for normal conditions. Note that the inlet and outlet vents were modeled explicitly, therefore, streaming through these components is accounted for in the dose calculations. Note again that the MPC is assumed to be positioned at its highest permissible elevation in relation to the inlet ducts (i.e., in the configuration shown in the drawings in Section 1.5) to maximize the calculated dose rates.

For the assumed accident condition during the construction phase, the model contains a VVM surrounded by 6.5 feet of soil (i.e. a thinner soil layer than the one required by the RPS of 10.5 ft), with a horizontal cylindrical hole (8 inch diameter) extending from the metal surface of the VVM to the outer surface of the soil. This condition is the result of the impact of a tornado missile with a diameter of 8 inches. Note that in the model the displaced soil and the missile itself are conservatively assumed to be lost. Also, the cylinder is conservatively assumed to be on the mid-height of the fuel. The dose location is on the axis of the cylindrical hole, 100 m from the VVM.

Since the HI-STORM 100U model uses principally the same MPC model as the calculations in the main body of this chapter, all figures, conservative modeling approximations, and modeling differences for the MPC shown in Section 5.3 are applicable to the calculations in this supplement. The differences between models and drawings for the module are listed and discussed here.

1. Minor penetrations in the body of the module (e.g. lift locations) are not modeled as these are small localized effects which will not affect the off-site dose rates.
2. The MPC supports and guides were conservatively neglected.
3. The closure lid cover plate was modeled as flat. This conservatively reduces the amount of concrete in the lid near the outlet vent.

HOLTEC INTERNATIONAL COPYRIGHTED MATERIAL

HI-STORM FSAR
REPORT HI-2002444

5.I-4

Rev. 9

4. The insulation installed on the divider shell was conservatively modeled as a void.
5. The cavities representing the ICCPS tube and the empty VVM are modeled as empty volumes surrounded by soil, i.e. any steel liner or other material in these areas, or any covers that would be located on top of those cavities, are conservatively neglected
6. The lid design contains a buttress rod at the center. This rod is not explicitly modeled, i.e. the steel of the rod is replaced with concrete in the model. This has a negligible effect on the dose rates.

Composition and densities of the various materials in Table 5.3.2 were used in the analyses, except for the soil composition. The soil composition and density is shown in Table 5.I.3, and represent typical soil conditions [5.I.1]. This is conservative, since the areas between and around the modules would contain engineered fill with a typical density higher than soil. Furthermore, the dose rates around the VVM are dominated by the streaming through the inlet and outlet vents, and not by direct radiation through the soil and concrete. This is evident by the fact that the dose rate calculated for the excavation site through 6.5 ft of radial soil (see Section 5.I.1) is much less than the dose rates around the inlet and outlet vents. To further substantiate this, a complete dose rate profile across the lid and the VIP was determined. For the VIP, two conditions were evaluated, the normal condition and a condition where the streaming from the inlets and outlets were artificially blocked. For this second condition, dose rates were also calculated at a distance of 100 m from the VVM. This would indicate what portion of the dose rate results from direct radiation through the concrete and soil of the VIP as opposed to radiation from the streaming from the air inlet and outlet. The dose locations for the profile are shown in Figure 5.I.3, and are labeled alphabetically (A through X). The calculated dose rates are listed in Table 5.I.4. For the VIP, dose rates are shown with the open inlets and outlets, and with the artificially closed inlets and outlets. The following conclusions can be drawn from the results:

- The profile did not reveal any locations with dose rates higher than those shown in Figure 5.I.1 and Table 5.I.1.
- On the VIP, the dose rates are fairly low compared to other areas.
- Comparison of the results on the VIP surface with open and artificially closed inlets and outlets show that closer to the VVM, the dose rate on the surface is dominated by the direct radiation through the concrete and soil, while at larger distances, the relative contribution of the direct radiation through the soil and concrete reduces. At a distance of 100 m, the dose rate from the VIP surface contributes about one third of the total dose rate.

Note that the dose location 1 m from the inlet vents (see Figure 5.I.1) is approximately above dose locations W and X shown in Figure 5.I.3. The 1 m dose will therefore include contributions from the inlet vent as well as the VIP surface, and does therefore represent both the contribution

from streaming through the inlet vent and from direct radiation through the soil and concrete of the VIP.

In summary, soil properties are conservative and its effect is included in the dose rate at 1 m from the inlet vent. The use of typical soil properties is therefore appropriate. Nevertheless, site specific analyses to demonstrate compliance with regulatory requirements should use appropriate site specific soil properties if these are substantially different from the properties used in this Supplement.

5.1.4 SHIELDING EVALUATION

Table 5.1.1 provides dose rates adjacent to and at 1 meter distance from the HI-STORM 100U module during normal conditions for the MPC-32. The table also includes dose rates at the top of the ICCPS tube and at the top of an empty cavity next to a loaded VVM. These results demonstrate that the dose rates around the HI-STORM 100U are exceptionally low for the very conservative burnup and cooling time combination analyzed. These results also show that the higher dose rate at the inlet vent is reduced by more than an order of magnitude at a distance of 1 meter from the vent.

Table 5.1.2 provides the annual dose at 100 meters from a HI-STORM 100U module for the MPC-32 including the contribution from BPRAs. These results clearly demonstrate that the off-site contribution from a HI-STORM 100U is a small fraction of the off-site dose from the above ground HI-STORM overpacks.

The bounding accident condition is the impact of a tornado missile during the expansion of an array of 100U modules. The dose calculated for this condition at a distance of 100 m is 1.4 rem, which is below the limit specified in 10CFR72, and also below the dose for the bounding accident condition determined in the main section of Chapter 5.

5.1.5 REGULATORY COMPLIANCE

In summary it can be concluded that dose rates from the HI-STORM 100U module are bounded by the dose rates for the overpacks analyzed in the main body of the report. The shielding system of the HI-STORM 100U System is therefore in compliance with 10CFR72 and satisfies the applicable design and acceptance criteria including 10CFR20. Thus, the shielding evaluation presented in this supplement provides reasonable assurance that the HI-STORM 100U System will allow safe storage of spent fuel.

5.1.6 REFERENCES

[5.1.1] ANSI/ANS-6.6.1-1987, "Calculation and Measurement of Direct and Scattered Gamma Radiation from LWR Nuclear Power Plants"

HOLTEC INTERNATIONAL COPYRIGHTED MATERIAL

HI-STORM FSAR
REPORT HI-2002444

5.1-6

Rev. 9

Table 5.I.1

DOSE RATES ADJACENT TO AND 1 METER FROM THE HI-STORM 100U MODULE FOR NORMAL CONDITIONS
MPC-32 DESIGN BASIS ZIRCALOY CLAD FUEL AT BOUNDING BURNUP AND COOLING TIME

Dose Point [†] Location	Burnup and Cooling Time (MWD/MTU / Years)	Fuel Gammas ^{††} (mrem/hr)	⁶⁰ Co Gammas (mrem/hr)	Neutrons (mrem/hr)	Totals (mrem/hr)	Totals with BPRAs (mrem/hr)
Surface						
1	69,000 / 5	41.70	8.24	15.08	65.02	69.43
2	69,000 / 5	3.03	1.07	4.84	8.94	9.39
3	69,000 / 5	16.83	3.59	5.08	25.50	27.91
4	69,000 / 5	11.62	10.23	25.69	47.54	51.73
5	45,000 / 3	3.38	2.83	7.60E-02	6.29	7.49
6 [‡]	45,000 / 3	0.40	6.6E-02	1.85E-02	0.48	0.52
One Meter						
1	69,000 / 5	3.44	0.70	1.41	5.56	5.92
2	69,000 / 5	0.93	0.44	0.92	2.30	2.49
3	69,000 / 5	5.10	1.07	1.50	7.67	8.49
4	69,000 / 5	2.97	0.68	1.96	5.61	6.03

[†] Refer to Figure 5.I.1.

^{††} Gammas generated by neutron capture are included with fuel gammas.

[‡] Calculated for an empty VVM surrounded by four loaded VVMs.

HOLTEC INTERNATIONAL COPYRIGHTED MATERIAL

Table 5.I.2

ANNUAL DOSE AT 100 METERS FROM A SINGLE
HI-STORM 100U OVERPACK WITH AN MPC-32 WITH DESIGN BASIS
ZIRCALOY CLAD FUEL[†]

Dose Component	69,000 MWD/MTU 5-Year Cooling (mrem/yr)
Fuel gammas ^{††}	4.01
⁶⁰ Co Gammas	1.22
Neutrons	3.27
Total	8.50

[†] 8760 hour annual occupancy is assumed.

^{††} Gammas generated by neutron capture are included with fuel gammas.

HOLTEC INTERNATIONAL COPYRIGHTED MATERIAL

Table 5.I.3

COMPOSITION OF THE MATERIALS IN THE HI-STORM 100U SYSTEM

Component	Density (g/cm ³)	Elements	Mass Fraction (%)
Soil	1.7	H	0.962
		O	54.361
		Al	12.859
		Si	31.818

HOLTEC INTERNATIONAL COPYRIGHTED MATERIAL

HI-STORM FSAR
REPORT HI-2002444

5.I-9

Rev. 9

Table 5.I.1

DOSE RATES ADJACENT TO THE HI-STORM 100U MODULE FOR NORMAL CONDITIONS AT DOSE LOCATIONS SHOWN IN FIGURE 5.I.3.

Note: All Values Are For 69,000 MWD/MTU And 5 Years Cooling, Except For Dose Location I Which Is For 60,000 MWD/MTU And 4 Years Cooling

Dose Location ^{††}	Dose Rate (mrem/hr unless noted)		Dose Location	Dose Rate (mrem/hr unless noted)	
	Inlet/Outlet Open	Inlet/Outlet Artificially Closed		Inlet/Outlet Open	Inlet/Outlet Artificially Closed
A	33.1	N/C [†]	N	2.0	N/C
B	16.7	N/C	O	3.5	N/C
C	15.7	N/C	P	9.3	N/C
D	9.3	N/C	Q	6.8	6.5
E	6.5	N/C	R	4.1	3.5
F	7.0	N/C	S	3.0	2.0
G	4.8	N/C	T	2.5	2.0
H	6.6	N/C	U	2.2	1.5
I	33.2	N/C	V	2.0	1.5
J	27.8	N/C	W	1.7	1.0
K	3.7	N/C	X	1.6	1.0
L	1.1	N/C	Y	8.5	2.8
M	1.3	N/C		mrem/year	mrem/year

^{††} See Figure 5.I.3

[†] N/C = Not Calculated

HOLTEC INTERNATIONAL COPYRIGHTED MATERIAL

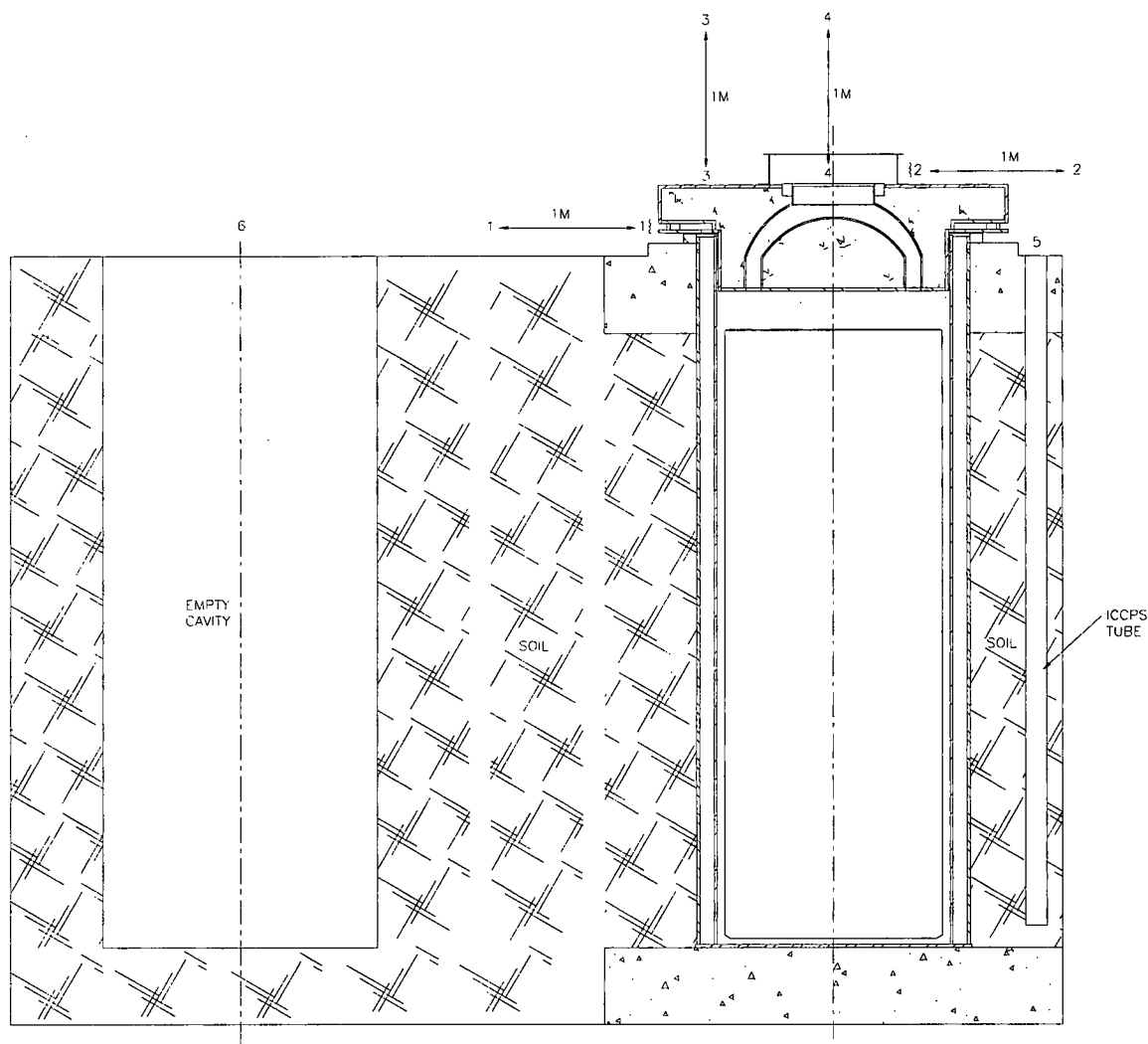


FIGURE 5.1.1; HI-STORM 100U MODULE CROSS SECTIONAL ELEVATION VIEW WITH DOSE POINT LOCATION

HOLTEC INTERNATIONAL COPYRIGHTED MATERIAL

HI-STORM FSAR
REPORT HI-2002444

5.1-11

Rev. 9

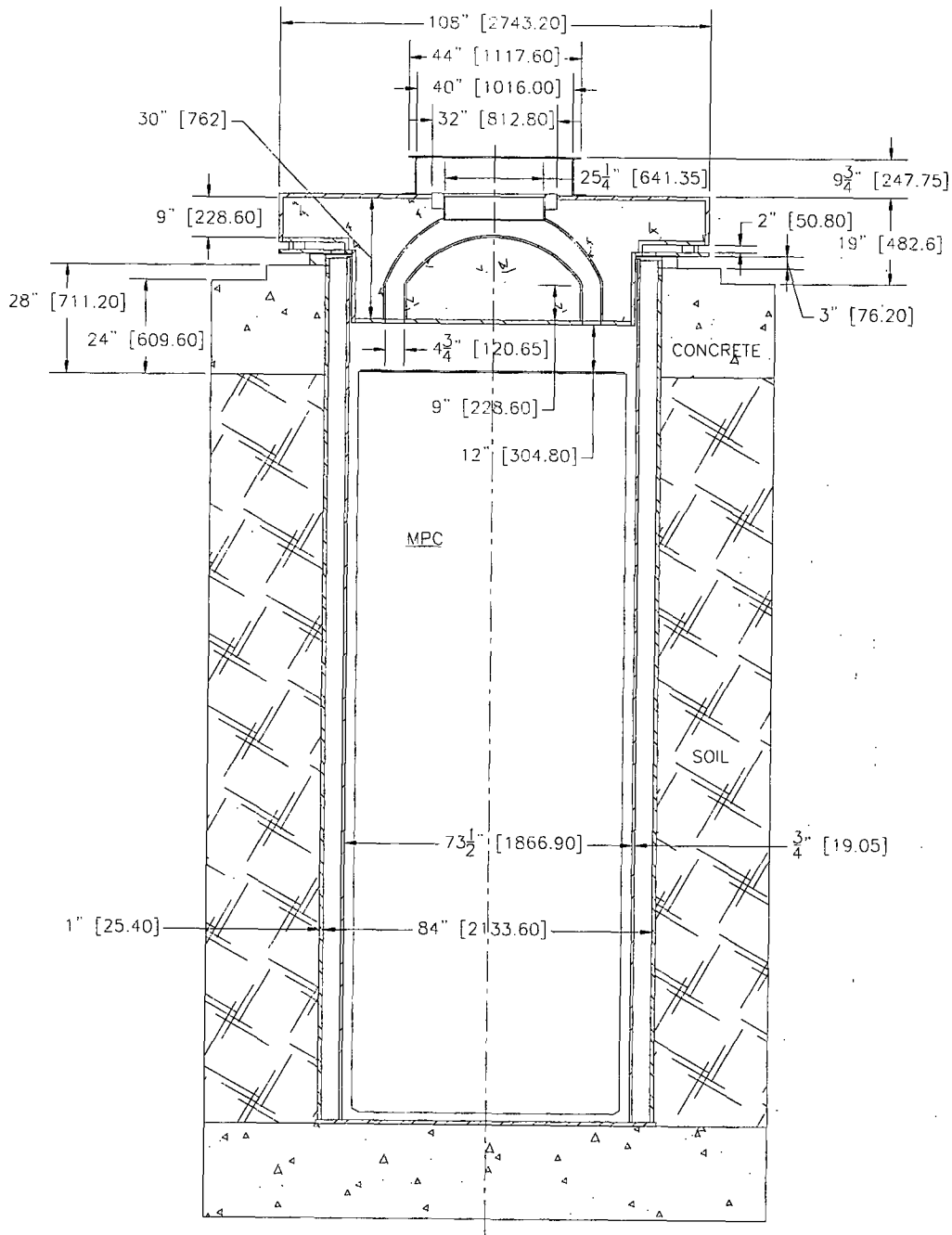


FIGURE 5.I.2; HI-STORM 100U MODULE CROSS SECTIONAL ELEVATION VIEW. VALUES IN BRACKETS ARE IN MILLIMETERS.

HOLTEC INTERNATIONAL COPYRIGHTED MATERIAL

HI-STORM FSAR
REPORT HI-2002444

5.I-12

Rev. 9

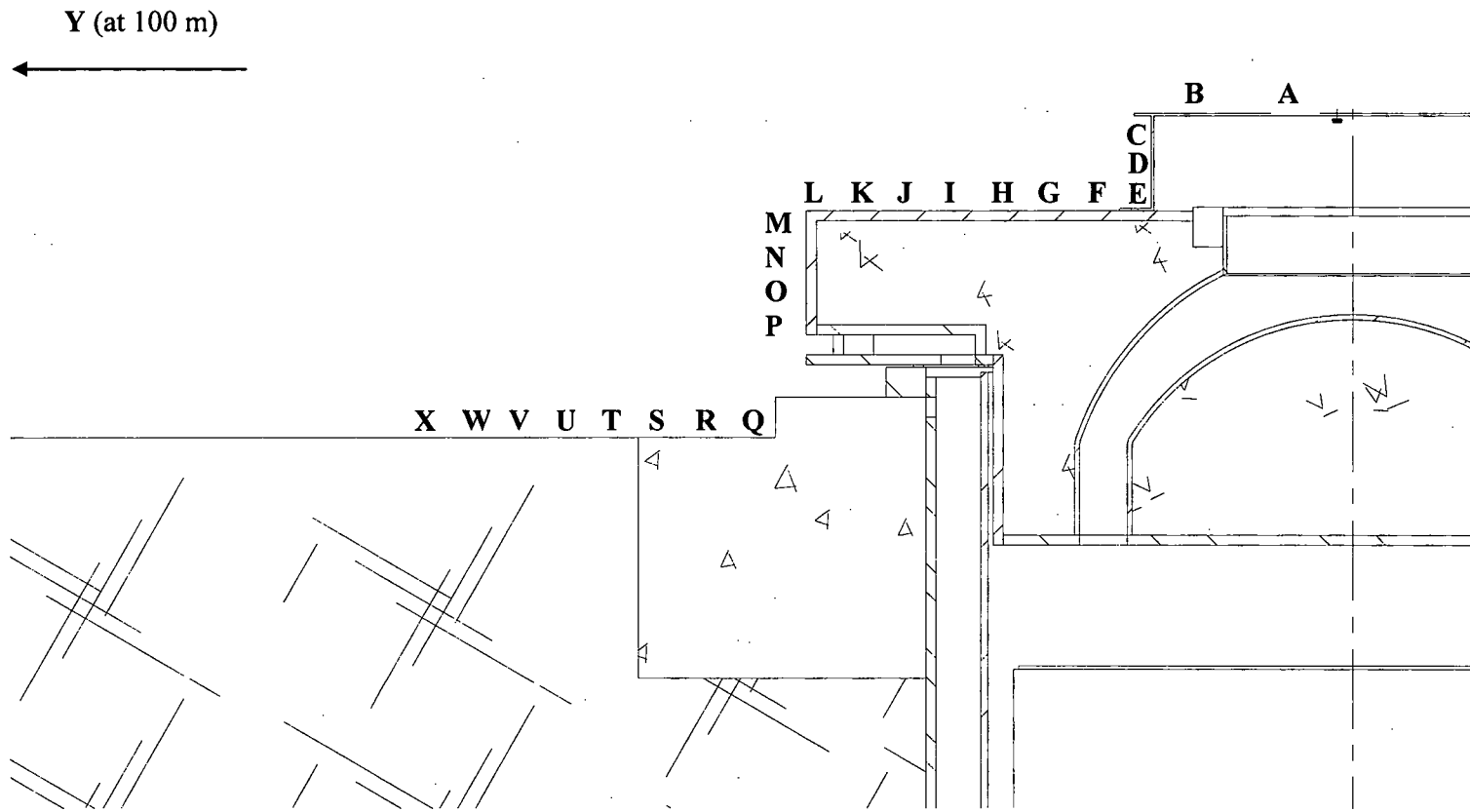


FIGURE 5.I.3; HI-STORM 100U MODULE CROSS SECTIONAL ELEVATION VIEW WITH DOSE POINT LOCATIONS

HOLTEC INTERNATIONAL COPYRIGHTED MATERIAL

HI-STORM FSAR
REPORT HI-2002444

5.I-13

Rev. 9

HI-STORM 100 FSAR, NON-PROPRIETARY
REVISION 12
MARCH 12, 2014

SUPPLEMENT 5.III

EVALUATION OF THE MPC-68M BASKET, AND THE 10x10F AND 10x10G ASSEMBLY CLASSES

5.III.0 DISCUSSION

The MPC-68M is a variation of the 68 cell BWR canister MPC-68 evaluated in the main part of this chapter, but with a basket design consisting of aluminum oxide and finely ground boron carbide dispersed in a metal matrix of pure aluminum. The boron carbide content is 10% (minimum) by weight. This results in a B-10 areal density that is slightly above that in the MPC-68. To show that the baskets are essentially identical from a shielding perspective, the relevant differences between the baskets are listed below, and then discussed in respect to its effect on the photon and neutron dose rates.

Differences between the MPC-68M compared to the MPC-68, in respect to the characteristics important for the dose calculations, are as follows:

- The MPC-68M has a slightly higher B-10 content
- The MPC-68M is lighter, since it consists of aluminum and boron carbide, but no steel
- In the enclosure shell, the MPC-68M is surrounded by aluminum basket shims

To evaluate the effect of these differences, studies in the main part of Chapter 5 regarding dose contributions from a regionalized loading scheme are utilized. These studies, described in Section 5.4, show that the inner region on an MPC-68 (32 assemblies = 47 % of the content) contributes about 27% of the neutron dose rate, but only about 2 % of the photon dose rate. This means that the self shielding of the fuel and basket for neutron radiation is low, while for photon radiation it is very high. The low neutron self shielding means that the neutron doses are not significantly affected by the reduced basket weight, since the majority of the neutron shielding function is provided by the overpack around the MPC. Also, for MPCs filled with water, there is a further reduction in neutron dose due to the increased absorption of thermal neutrons from the increased B-10 loading. The high self shielding for photons means that only the outer basket panels are effective for gamma shielding. For the MPC-68M, the shielding in this area is enhanced due to the presence of the basket shims, and therefore comparable to the absorption in the steel basket walls. In summary, the effect of the design differences between MPC-68 and MPC-68M on dose rates is small. Therefore, no specific dose calculations are performed for the MPC-68M, and all results and conclusions from the MPC-68 are directly applicable here.

Additionally, two BWR array classes designated 10x10F and 10x10G have been added as approved contents in the MPC-68M only. From a radiological perspective, the additional array classes are bounded by the design basis GE 7x7 source term calculations, since those design basis assemblies have higher initial uranium masses. In terms of grouping assemblies for the polynomial factors presented in Section 2.1.9, the new array classes are added to groups which represent assemblies of a higher mass. This is conservative since a heavier assembly results in a

higher decay heat, which reduces the allowable assembly burnup. In summary, no new analyses are necessary to qualify those additional array classes.

Therefore, the main body of this chapter remains fully applicable for the HI-STORM 100 System using an MPC-68M and the new assembly classes.

CHAPTER 6[†]: CRITICALITY EVALUATION

This chapter documents the criticality evaluation of the HI-STORM 100 System for the storage of spent nuclear fuel in accordance with 10CFR72.124. The results of this evaluation demonstrate that the HI-STORM 100 System is consistent with the Standard Review Plan for Dry Cask Storage Systems, NUREG-1536, and thus, fulfills the following acceptance criteria:

1. The multiplication factor (k_{eff}), including all biases and uncertainties at a 95-percent confidence level, should not exceed 0.95 under all credible normal, off-normal, and accident conditions.
2. At least two unlikely, independent, and concurrent or sequential changes to the conditions essential to criticality safety, under normal, off-normal, and accident conditions, should occur before an accidental criticality is deemed to be possible.
3. When practicable, criticality safety of the design should be established on the basis of favorable geometry, permanent fixed neutron-absorbing materials (poisons), or both.
4. Criticality safety of the cask system should not rely on use of the following credits:
 - a. burnup of the fuel
 - b. fuel-related burnable neutron absorbers
 - c. more than 75 percent for fixed neutron absorbers when subject to standard acceptance test^{††}.

In addition to demonstrating that the criticality safety acceptance criteria are satisfied, this chapter describes the HI-STORM 100 System design structures and components important to criticality safety and defines the limiting fuel characteristics in sufficient detail to identify the package accurately and provide a sufficient basis for the evaluation of the package. Analyses for the HI-STAR 100 System, which are applicable to the HI-STORM 100 System, have been previously submitted to the USNRC under Docket Numbers 72-1008 and 71-9261.

[†] This chapter has been prepared in the format and section organization set forth in Regulatory Guide 3.61. However, the material content of this chapter also fulfills the requirements of NUREG-1536. Pagination and numbering of sections, figures, and tables are consistent with the convention set down in *Chapter 1*, Section 1.0, herein. Finally, all terms-of-art used in this chapter are consistent with the terminology of the glossary (Table 1.0.1) and component nomenclature of the Bill-of-Materials (Section 1.5).

^{††} For greater credit allowance, fabrication tests capable of verifying the presence and uniformity of the neutron absorber are needed.

HOLTEC INTERNATIONAL COPYRIGHTED MATERIAL

REPORT HI-2002444

6.1-1

Rev. 11

In conformance with the principles established in NUREG-1536 [6.1.1], 10CFR72.124 [6.1.2], and NUREG-0800 Section 9.1.2 [6.1.3], the results in this chapter demonstrate that the effective multiplication factor (k_{eff}) of the HI-STORM 100 System, including all biases and uncertainties evaluated with a 95% probability at the 95% confidence level, does not exceed 0.95 under all credible normal, off-normal, and accident conditions. Moreover, these results demonstrate that the HI-STORM 100 System is designed and maintained such that at least two unlikely, independent, and concurrent or sequential changes must occur to the conditions essential to criticality safety before a nuclear criticality accident is possible. These criteria provide a large subcritical margin, sufficient to assure the criticality safety of the HI-STORM 100 System when fully loaded with fuel of the highest permissible reactivity.

Criticality safety of the HI-STORM 100 System depends on the following four principal design parameters:

1. The inherent geometry of the fuel basket designs within the MPC (and the flux-trap water gaps in the MPC-24 and MPC-24E);
2. The incorporation of permanent fixed neutron-absorbing panels in the fuel basket structure;
3. An administrative limit on the maximum enrichment for PWR fuel and maximum planar-average enrichment for BWR fuel; and
4. An administrative limit on the minimum soluble boron concentration in the water for loading/unloading fuel with higher enrichments in the MPC-24 and MPC-24E, and for loading/unloading fuel in the MPC-32.

The off-normal and accident conditions defined in Chapter 2 and considered in Chapter 11 have no adverse effect on the design parameters important to criticality safety, and thus, the off-normal and accident conditions are identical to those for normal conditions.

The HI-STORM 100 System is designed such that the fixed neutron absorber will remain effective for a storage period greater than 20 years, and there are no credible means to lose it. Therefore, in accordance with 10CFR72.124(b), there is no need to provide a surveillance or monitoring program to verify the continued efficacy of the neutron absorber.

Criticality safety of the HI-STORM 100 System does not rely on the use of any of the following credits:

- burnup of fuel
- fuel-related burnable neutron absorbers
- more than 75 percent of the B-10 content for the Boral fixed neutron absorber
- more than 90 percent of the B-10 content for the Metamic fixed neutron absorber, with comprehensive fabrication tests as described in Section 9.1.5.3.2.

The following four interchangeable basket designs are available for use in the HI-STORM 100 System:

- a 24-cell basket (MPC-24), designed for intact PWR fuel assemblies with a specified maximum enrichment and, for higher enrichments, a minimum soluble boron concentration in the pool water for loading/unloading operations,
- a 24-cell basket (MPC-24E) for intact and damaged PWR fuel assemblies. This is a variation of the MPC-24, with an optimized cell arrangement, increased ^{10}B content in the fixed neutron absorber and with four cells capable of accommodating either intact fuel or a damaged fuel container (DFC) containing damaged PWR fuel assemblies or PWR fuel debris. The MPC-24E is designed for fuel assemblies with a specified maximum enrichment and, for higher enrichments, a minimum soluble boron concentration in the pool water for loading/unloading operations,
- a 32-cell basket (MPC-32), designed for intact, damaged PWR fuel assemblies, and PWR fuel debris of a specified maximum enrichment and minimum soluble boron concentration for loading/unloading. And
- a 68-cell basket (MPC-68), designed for intact and damaged BWR fuel assemblies, and BWR fuel debris with a specified maximum planar-average enrichment. Additionally, a variation in the MPC-68, designated MPC-68F, is designed for specific intact and damaged BWR fuel assemblies and BWR fuel debris with a specified maximum planar-average enrichment.

Two interchangeable neutron absorber materials are used in these baskets, Boral and Metamic. For Boral, 75 percent of the minimum B-10 content is credited in the criticality analysis, while for Metamic, 90 percent of the minimum B-10 content is credited, based on the neutron absorber tests specified in Section 9.1.5.3. However, the B-10 content in Metamic is chosen to be lower

HOLTEC INTERNATIONAL COPYRIGHTED MATERIAL

REPORT HI-2002444

6.1-3

Rev. 11

than the B-10 content in Boral, and is chosen so that the absolute B-10 content credited in the criticality analysis is the same for the two materials. This makes the two materials identical from a criticality perspective. This is confirmed by comparing results for a selected number of cases that were performed with both materials (see Section 6.4.11). Calculations in this chapter are therefore only performed for the Boral neutron absorber, with results directly applicable to Metamic.

The HI-STORM 100 System includes the HI-TRAC transfer cask and the HI-STORM storage cask. The HI-TRAC transfer cask is required for loading and unloading fuel into the MPC and for transfer of the MPC into the HI-STORM storage cask. HI-TRAC uses a lead shield for gamma radiation and a water-filled jacket for neutron shielding. The HI-STORM storage cask uses concrete as a shield for both gamma and neutron radiation. Both the HI-TRAC transfer cask and the HI-STORM storage cask, as well as the HI-STAR System[†], accommodate the interchangeable MPC designs. The three cask designs (HI-STAR, HI-STORM, and HI-TRAC) differ only in the overpack reflector materials (steel for HI-STAR, concrete for HI-STORM, and lead for HI-TRAC), which do not significantly affect the reactivity. Consequently, analyses for the HI-STAR System are directly applicable to the HI-STORM 100 system and vice versa. Therefore, the majority of criticality calculations to support both the HI-STAR and the HI-STORM System have been performed for only one of the two systems, namely the HI-STAR System. Only a selected number of analyses has been performed for both systems to demonstrate that this approach is valid. Therefore, unless specifically noted otherwise, all analyses documented throughout this chapter have been performed for the HI-STAR System. For the cases where analyses were performed for both the HI-STORM and HI-STAR System, this is clearly indicated.

The HI-STORM 100 System for storage (concrete overpack) is dry (no moderator), and thus, the reactivity is very low ($k_{\text{eff}} < 0.52$). However, the HI-STORM 100 System for cask transfer (HI-TRAC, lead overpack) is flooded for loading and unloading operations, and thus, represents the limiting case in terms of reactivity.

The MPC-24EF, MPC-32F and MPC-68FF contain the same basket as the MPC-24E, MPC-32 and MPC-68, respectively. More specifically, all dimensions relevant to the criticality analyses are identical between the MPC-24E and MPC-24EF, the MPC-32 and MPC-32F, and the MPC-68 and MPC-68FF. Therefore, all criticality results obtained for the MPC-24E, MPC-32 and MPC-68 are valid for the MPC-24EF, MPC-32F and MPC-68FF, respectively, and no separate analyses for the MPC-24EF, MPC-32F and MPC-68FF are necessary. Therefore, throughout this chapter and unless otherwise noted, 'MPC-68' refers to 'MPC-68 and/or MPC-68FF', 'MPC-24E' or 'MPC-24E/EF' refers to 'MPC-24E and/or MPC-24EF', and 'MPC-32' or 'MPC-32/32F' refers to 'MPC-32 and/or MPC-32F'.

[†] Analyses for the HI-STAR System have previously been submitted to the USNRC under Docket Numbers 72-1008 and 71-9261.

HOLTEC INTERNATIONAL COPYRIGHTED MATERIAL

Confirmation of the criticality safety of the HI-STORM 100 System was accomplished with the three-dimensional Monte Carlo code MCNP4a [6.1.4]. Independent confirmatory calculations were made with NITAWL-KENO5a from the SCALE-4.3 package [6.4.1]. KENO5a [6.1.5] calculations used the 238-group SCALE cross-section library in association with the NITAWL-II program [6.1.6], which adjusts the uranium-238 cross sections to compensate for resonance self-shielding effects. The Dancoff factors required by NITAWL-II were calculated with the CELLDAN code [6.1.13], which includes the SUPERDAN code [6.1.7] as a subroutine. K-factors for one-sided statistical tolerance limits with 95% probability at the 95% confidence level were obtained from the National Bureau of Standards (now NIST) Handbook 91 [6.1.8].

To assess the incremental reactivity effects due to manufacturing tolerances, CASMO-3, a two-dimensional transport theory code [6.1.9-6.1.12] for fuel assemblies, and MCNP4a [6.1.4] were used. The CASMO-3 and MCNP4a calculations identify those tolerances that cause a positive reactivity effect, enabling the subsequent Monte Carlo code input to define the worst case (most conservative) conditions. CASMO-3 was not used for quantitative information, but only to qualitatively indicate the direction and approximate magnitude of the reactivity effects of the manufacturing tolerances.

Benchmark calculations were made to compare the primary code packages (MCNP4a and KENO5a) with experimental data, using critical experiments selected to encompass, insofar as practical, the design parameters of the HI-STORM 100 System. The most important parameters are (1) the enrichment, (2) the water-gap size (MPC-24 and MPC-24E) or cell spacing (MPC-32, MPC-68, and MPC-68F), (3) the ^{10}B loading of the neutron absorber panels, and (4) the soluble boron concentration in the water. The critical experiment benchmarking is presented in Appendix 6.A.

Applicable codes, standards, and regulations, or pertinent sections thereof, include the following:

- NUREG-1536, Standard Review Plan for Dry Cask Storage Systems, USNRC, Washington D.C., January 1997.
- 10CFR72.124, Criteria For Nuclear Criticality Safety.
- Code of Federal Regulations, Title 10, Part 50, Appendix A, General Design Criterion 62, Prevention of Criticality in Fuel Storage and Handling.
- USNRC Standard Review Plan, NUREG-0800, Section 9.1.2, Spent Fuel Storage, Rev. 3, July 1981.

To assure the true reactivity will always be less than the calculated reactivity, the following conservative design criteria and assumptions were made:

- The MPCs are assumed to contain the most reactive fresh fuel authorized to be loaded into a

HOLTEC INTERNATIONAL COPYRIGHTED MATERIAL

specific basket design.

- Consistent with NUREG-1536, no credit for fuel burnup is assumed, either in depleting the quantity of fissile nuclides or in producing fission product poisons.
- Consistent with NUREG-1536, the criticality analyses assume 75% of the manufacturer's minimum Boron-10 content for the Boral neutron absorber and 90% of the manufacturer's minimum Boron-10 content for the Metamic neutron absorber.
- The fuel stack density is conservatively assumed to be at least 96% of theoretical (10.522 g/cm³) for all criticality analyses. Fuel stack density is approximately equal to 98% of the pellet density. Therefore, while the pellet density of some fuels may be slightly greater than 96% of theoretical, the actual stack density will be less.
- No credit is taken for the ²³⁴U and ²³⁶U in the fuel.
- When flooded, the moderator is assumed to be water, with or without soluble boron, at a temperature and density corresponding to the highest reactivity within the expected operating range.
- When credit is taken for soluble boron, a ¹⁰B content of 18.0 wt% in boron is assumed.
- Neutron absorption in minor structural members and optional heat conduction elements is neglected, i.e., spacer grids, basket supports, and optional aluminum heat conduction elements are replaced by water.
- Consistent with NUREG-1536, the worst hypothetical combination of tolerances (most conservative values within the range of acceptable values), as identified in Section 6.3, is assumed.
- When flooded, the fuel rod pellet-to-clad gap regions are assumed to be flooded with pure unborated water.
- Planar-averaged enrichments are assumed for BWR fuel. (Consistent with NUREG-1536, analysis is presented in Appendix 6.B to demonstrate that the use of planar-average enrichments produces conservative results.)
- Consistent with NUREG-1536, fuel-related burnable neutron absorbers, such as the Gadolinia normally used in BWR fuel and IFBA normally used in PWR fuel, are neglected.
- For evaluation of the bias, all benchmark calculations that result in a k_{eff} greater than 1.0 are conservatively truncated to 1.0000, consistent with NUREG-1536.

HOLTEC INTERNATIONAL COPYRIGHTED MATERIAL

REPORT HI-2002444

6.1-6

Rev. 11

- The water reflector above and below the fuel is assumed to be unborated water, even if borated water is used in the fuel region.
- For fuel assemblies that contain low-enriched axial blankets, the governing enrichment is that of the highest planar average, and the blankets are not included in determining the average enrichment.
- Regarding the position of assemblies in the basket, configurations with centered and eccentric positioning of assemblies in the fuel storage locations are considered. For further discussions see Section 6.3.3.
- For intact fuel assemblies, as defined in Table 1.0.1, missing fuel rods must be replaced with dummy rods that displace a volume of water that is equal to, or larger than, that displaced by the original rods.

Results of the design basis criticality safety calculations for single internally flooded HI-TRAC transfer casks with full water reflection on all sides (limiting cases for the HI-STORM 100 System), and for single unreflected, internally flooded HI-STAR casks (limiting cases for the HI-STAR 100 System), loaded with intact fuel assemblies are listed in Tables 6.1.1 through 6.1.8, conservatively evaluated for the worst combination of manufacturing tolerances (as identified in Section 6.3), and including the calculational bias, uncertainties, and calculational statistics. Comparing corresponding results for the HI-TRAC and HI-STAR demonstrates that the overpack material does not significantly affect the reactivity. Consequently, analyses for the HI-STAR System are directly applicable to the HI-STORM 100 System and vice versa. In addition, a few results for single internally dry (no moderator) HI-STORM storage casks with full water reflection on all external surfaces of the overpack, including the annulus region between the MPC and overpack, are listed to confirm the low reactivity of the HI-STORM 100 System in storage.

For each of the MPC designs, minimum soluble boron concentration (if applicable) and fuel assembly classes^{††}, Tables 6.1.1 through 6.1.8 list the bounding maximum k_{eff} value, and the associated maximum allowable enrichment. The maximum allowed enrichments and the minimum soluble boron concentrations are also listed in Section 2.1.9. The candidate fuel assemblies, that are bounded by those listed in Tables 6.1.1 through 6.1.8, are given in Section 6.2.

^{††} For each array size (e.g., 6x6, 7x7, 14x14, etc.), the fuel assemblies have been subdivided into a number of assembly classes, where an assembly class is defined in terms of the (1) number of fuel rods; (2) pitch; (3) number and location of guide tubes (PWR) or water rods (BWR); and (4) cladding material. The assembly classes for BWR and PWR fuel are defined in Section 6.2.

Results of the design basis criticality safety calculations for single unreflected, internally flooded casks (limiting cases) loaded with damaged fuel assemblies or a combination of intact and damaged fuel assemblies are listed in Tables 6.1.9 through 6.1.12. The results include the calculational bias, uncertainties, and calculational statistics. For each of the MPC designs qualified for damaged fuel and/or fuel debris (MPC-24E, MPC-68, MPC-68F, MPC-32), Tables 6.1.9 through 6.1.12 indicate the maximum number of DFCs and list the fuel assembly classes, the bounding maximum k_{eff} value, the associated maximum allowable enrichment, and if applicable the minimum soluble boron concentration. For the permissible location of DFCs see Subsection 6.4.4.2. The maximum allowed enrichments are also listed in Section 2.1.9.

A table listing the maximum k_{eff} (including bias, uncertainties, and calculational statistics), calculated k_{eff} , standard deviation, and energy of the average lethargy causing fission (EALF) for each of the candidate fuel assemblies and basket configurations is provided in Appendix 6.C. These results confirm that the maximum k_{eff} values for the HI-STORM 100 System are below the limiting design criteria ($k_{eff} < 0.95$) when fully flooded and loaded with any of the candidate fuel assemblies and basket configurations. Analyses for the various conditions of flooding that support the conclusion that the fully flooded condition corresponds to the highest reactivity, and thus is most limiting, are presented in Section 6.4. The capability of the HI-STORM 100 System to safely accommodate damaged fuel and fuel debris is demonstrated in Subsection 6.4.4.

Accident conditions have also been considered and no credible accident has been identified that would result in exceeding the design criteria limit on reactivity. After the MPC is loaded with spent fuel, it is seal-welded and cannot be internally flooded. The HI-STORM 100 System for storage is dry (no moderator) and the reactivity is very low. For arrays of HI-STORM storage casks, the radiation shielding and the physical separation between overpacks due to the large diameter and cask pitch preclude any significant neutronic coupling between the casks.

HOLTEC INTERNATIONAL COPYRIGHTED MATERIAL

REPORT HI-2002444

6.1-8

Rev. 11

Table 6.1.1

BOUNDING MAXIMUM k_{eff} VALUES FOR EACH ASSEMBLY CLASS IN THE MPC-24
(no soluble boron)

Fuel Assembly Class	Maximum Allowable Enrichment (wt% ^{235}U)	Maximum k_{eff}		
		HI-STORM	HI-TRAC	HI-STAR
14x14A	4.6	0.3080	0.9283	0.9296
14x14B	4.6	---	0.9237	0.9228
14x14C	4.6	---	0.9274	0.9287
14x14D	4.0	---	0.8531	0.8507
14x14E	5.0 [†]	---	0.7627	0.7627
15x15A	4.1	---	0.9205	0.9204
15x15B	4.1	---	0.9387	0.9388
15x15C	4.1	---	0.9362	0.9361
15x15D	4.1	---	0.9354	0.9367
15x15E	4.1	---	0.9392	0.9368
15x15F	4.1	0.3648	0.9393 ^{††}	0.9395 ^{†††}
15x15G	4.0	---	0.8878	0.8876
15x15H	3.8	---	0.9333	0.9337
16x16A	4.6	0.3588	0.9322	0.9327
17x17A	4.0	0.3243	0.9378	0.9368
17x17B	4.0	---	0.9318	0.9324
17x17C	4.0	---	0.9319	0.9336

Note: The HI-STORM results are for internally dry (no moderator) HI-STORM storage casks with full water reflection on all sides, the HI-TRAC results are for internally fully flooded HI-TRAC transfer casks (which are part of the HI-STORM 100 System) with full water reflection on all sides, and the HI-STAR results are for unreflected, internally fully flooded HI-STAR casks.

[†] The term "maximum k_{eff} " as used here, and elsewhere in this document, means the highest possible k_{eff} , including bias, uncertainties, and calculational statistics, evaluated for the worst case combination of manufacturing tolerances.

[‡] (Footnote deleted)

^{††} KENO5a verification calculation resulted in a maximum k_{eff} of 0.9383.

^{†††} KENO5a verification calculation resulted in a maximum k_{eff} of 0.9378.

HOLTEC INTERNATIONAL COPYRIGHTED MATERIAL

REPORT HI-2002444

6.1-9

Rev. 11

Table 6.1.2

BOUNDING MAXIMUM k_{eff} VALUES FOR EACH ASSEMBLY CLASS IN THE MPC-24
WITH 400 PPM SOLUBLE BORON

Fuel Assembly Class	Maximum Allowable Enrichment (wt% ^{235}U)	Maximum [†] k_{eff}		
		HI-STORM	HI-TRAC	HI-STAR
14x14A	5.0	---	---	0.8884
14x14B	5.0	---	---	0.8900
14x14C	5.0	---	---	0.8950
14x14D	5.0	---	---	0.8518
14x14E	5.0 [‡]	---	---	0.7132
15x15A	5.0	---	---	0.9119
15x15B	5.0	---	---	0.9284
15x15C	5.0	---	---	0.9236
15x15D	5.0	---	---	0.9261
15x15E	5.0	---	---	0.9265
15x15F	5.0	0.4013	0.9301	0.9314
15x15G	5.0	---	---	0.8939
15x15H	5.0	---	0.9345	0.9366
16x16A	5.0	---	---	0.8993
17x17A	5.0	---	---	0.9264
17x17B	5.0	---	---	0.9284
17x17C	5.0	---	0.9296	0.9294

Note: The HI-STORM results are for internally dry (no moderator) HI-STORM storage casks with full water reflection on all sides, the HI-TRAC results are for internally fully flooded HI-TRAC transfer casks (which are part of the HI-STORM 100 System) with full water reflection on all sides, and the HI-STAR results are for unreflected, internally fully flooded HI-STAR casks.

† The term "maximum k_{eff} " as used here, and elsewhere in this document, means the highest possible k -effective, including bias, uncertainties, and calculational statistics, evaluated for the worst case combination of manufacturing tolerances.

‡ (Footnote deleted)

HOLTEC INTERNATIONAL COPYRIGHTED MATERIAL

REPORT HI-2002444

6.1-10

Rev. 11

Table 6.1.3

BOUNDING MAXIMUM k_{eff} VALUES FOR EACH ASSEMBLY CLASS IN THE MPC-24E
(no soluble boron)

Fuel Assembly Class	Maximum Allowable Enrichment (wt% ^{235}U)	Maximum [†] k_{eff}		
		HI-STORM	HI-TRAC	HI-STAR
14x14A	5.0	---	---	0.9380
14x14B	5.0	---	---	0.9312
14x14C	5.0	---	---	0.9356
14x14D	5.0	---	---	0.8875
14x14E	5.0 [‡]	---	---	0.7651
15x15A	4.5	---	---	0.9336
15x15B	4.5	---	---	0.9465
15x15C	4.5	---	---	0.9462
15x15D	4.5	---	---	0.9440
15x15E	4.5	---	---	0.9455
15x15F	4.5	0.3699	0.9465	0.9468
15x15G	4.5	---	---	0.9054
15x15H	4.2	---	---	0.9423
16x16A	5.0	---	---	0.9394
17x17A	4.4	---	0.9467	0.9447
17x17B	4.4	---	---	0.9421
17x17C	4.4	---	---	0.9433

Note: The HI-STORM results are for internally dry (no moderator) HI-STORM storage casks with full water reflection on all sides, the HI-TRAC results are for internally fully flooded HI-TRAC transfer casks (which are part of the HI-STORM 100 System) with full water reflection on all sides, and the HI-STAR results are for unreflected, internally fully flooded HI-STAR casks.

[†] The term "maximum k_{eff} " as used here, and elsewhere in this document, means the highest possible k-effective, including bias, uncertainties, and calculational statistics, evaluated for the worst case combination of manufacturing tolerances.

[‡] (Footnote deleted)

HOLTEC INTERNATIONAL COPYRIGHTED MATERIAL

REPORT HI-2002444

6.1-11

Rev. 11.

Table 6.1.4

BOUNDING MAXIMUM k_{eff} VALUES FOR EACH ASSEMBLY CLASS IN THE MPC-24E
WITH 300 PPM SOLUBLE BORON

Fuel Assembly Class	Maximum Allowable Enrichment (wt% ^{235}U)	Maximum [†] k_{eff}		
		HI-STORM	HI-TRAC	HI-STAR
14x14A	5.0	---	---	0.8963
14x14B	5.0	---	---	0.8974
14x14C	5.0	---	---	0.9031
14x14D	5.0	---	---	0.8588
14x14E	5.0 [‡]	---	---	0.7249
15x15A	5.0	---	---	0.9161
15x15B	5.0	---	---	0.9321
15x15C	5.0	---	---	0.9271
15x15D	5.0	---	---	0.9290
15x15E	5.0	---	---	0.9309
15x15F	5.0	0.3897	0.9333	0.9332
15x15G	5.0	---	---	0.8972
15x15H	5.0	---	0.9399	0.9399
16x16A	5.0	---	---	0.9060
17x17A	5.0	---	0.9320	0.9332
17x17B	5.0	---	---	0.9316
17x17C	5.0	---	---	0.9312

Note: The HI-STORM results are for internally dry (no moderator) HI-STORM storage casks with full water reflection on all sides, the HI-TRAC results are for internally fully flooded HI-TRAC transfer casks (which are part of the HI-STORM 100 System) with full water reflection on all sides, and the HI-STAR results are for unreflected, internally fully flooded HI-STAR casks.

[†] The term "maximum k_{eff} " as used here, and elsewhere in this document, means the highest possible k-effective, including bias, uncertainties, and calculational statistics, evaluated for the worst case combination of manufacturing tolerances.

[‡] (Footnote deleted)

HOLTEC INTERNATIONAL COPYRIGHTED MATERIAL

Table 6.1.5

BOUNDING MAXIMUM k_{eff} VALUES FOR EACH ASSEMBLY CLASS IN THE MPC-32
FOR 4.1% ENRICHMENT

Fuel Assembly Class	Maximum Allowable Enrichment (wt% ^{235}U)	Minimum Soluble Boron Concentration (ppm) *	Maximum † k_{eff}		
			HI-STORM	HI-TRAC	HI-STAR
14x14A	4.1	1300	---	---	0.9041
14x14B	4.1	1300	---	---	0.9257
14x14C	4.1	1300	---	---	0.9423
14x14D	4.1	1300	---	---	0.8970
14x14E	4.1	1300	---	---	0.7340
15x15A	4.1	1800	---	---	0.9206
15x15B	4.1	1800	---	---	0.9397
15x15C	4.1	1800	---	---	0.9266
15x15D	4.1	1900	---	---	0.9384
15x15E	4.1	1900	---	---	0.9365
15x15F	4.1	1900	0.4691	0.9403	0.9411
15x15G	4.1	1800	---	---	0.9147
15x15H	4.1	1900	---	---	0.9276
15x15I	4.1	1800	---	---	0.9340
16x16A	4.1	1400	---	---	0.9375
17x17A	4.1	1900	---	---	0.9111
17x17B	4.1	1900	---	---	0.9309
17x17C	4.1	1900	---	0.9365	0.9355

Note: The HI-STORM results are for internally dry (no moderator) HI-STORM storage casks with full water reflection on all sides, the HI-TRAC results are for internally fully flooded HI-TRAC transfer casks (which are part of the HI-STORM 100 System) with full water reflection on all sides, and the HI-STAR results are for unreflected, internally fully flooded HI-STAR casks.

* For maximum allowable enrichments between 4.1 wt% ^{235}U and 5.0 wt% ^{235}U , the minimum soluble boron concentration may be calculated by linear interpolation between the minimum soluble boron concentrations specified in Table 6.1.5 and Table 6.1.6 for each assembly class.

† The term "maximum k_{eff} " as used here, and elsewhere in this document, means the highest possible k -effective, including bias, uncertainties, and calculational statistics, evaluated for the worst case combination of manufacturing tolerances.

HOLTEC INTERNATIONAL COPYRIGHTED MATERIAL

Table 6.1.6
 BOUNDING MAXIMUM k_{eff} VALUES FOR EACH ASSEMBLY CLASS IN THE MPC-32
 FOR 5.0% ENRICHMENT

Fuel Assembly Class	Maximum Allowable Enrichment (wt% ^{235}U)	Minimum Soluble Boron Concentration (ppm) [*]	Maximum [†] k_{eff}		
			HI-STORM	HI-TRAC	HI-STAR
14x14A	5.0	1900	---	---	0.9000
14x14B	5.0	1900	---	---	0.9214
14x14C	5.0	1900	---	---	0.9480
14x14D	5.0	1900	---	---	0.9050
14x14E	5.0	1900	---	---	0.7415
15x15A	5.0	2500	---	---	0.9230
15x15B	5.0	2500	---	---	0.9429
15x15C	5.0	2500	---	---	0.9307
15x15D	5.0	2600	---	---	0.9466
15x15E	5.0	2600	---	---	0.9434
15x15F	5.0	2600	0.5142	0.9470	0.9483
15x15G	5.0	2500	---	---	0.9251
15x15H	5.0	2600	---	---	0.9333
15x15I	5.0	2500	---	---	0.9402
16x16A	5.0	2000	---	---	0.9429
17x17A	5.0	2600	---	---	0.9161
17x17B	5.0	2600	---	---	0.9371
17x17C	5.0	2600	---	0.9436	0.9437

Note: The HI-STORM results are for internally dry (no moderator) HI-STORM storage casks with full water reflection on all sides, the HI-TRAC results are for internally fully flooded HI-TRAC transfer casks (which are part of the HI-STORM 100 System) with full water reflection on all sides, and the HI-STAR results are for unreflected, internally fully flooded HI-STAR casks.

* For maximum allowable enrichments between 4.1 wt% ^{235}U and 5.0 wt% ^{235}U , the minimum soluble boron concentration may be calculated by linear interpolation between the minimum soluble boron concentrations specified in Table 6.1.5 and Table 6.1.6 for each assembly class.

† The term "maximum k_{eff} " as used here, and elsewhere in this document, means the highest possible k-effective, including bias, uncertainties, and calculational statistics, evaluated for the worst case combination of manufacturing tolerances.

Table 6.1.7

BOUNDED MAXIMUM k_{eff} VALUES FOR EACH ASSEMBLY CLASS IN THE MPC-68

Fuel Assembly Class	Maximum Allowable Planar-Average Enrichment (wt% ^{235}U)	Maximum [†] k_{eff}		
		HI-STORM	HI-TRAC	HI-STAR
6x6A	2.7 ^{††}	---	0.7886	0.7888 ^{†††}
6x6B [‡]	2.7 ^{††}	---	0.7833	0.7824 ^{†††}
6x6C	2.7 ^{††}	0.2759	0.8024	0.8021 ^{†††}
7x7A	2.7 ^{††}	---	0.7963	0.7974 ^{†††}
7x7B	4.2	0.4061	0.9385	0.9386
8x8A	2.7 ^{††}	---	0.7690	0.7697 ^{†††}
8x8B	4.2	0.3934	0.9427	0.9416
8x8C	4.2	0.3714	0.9429	0.9425
8x8D	4.2	---	0.9408	0.9403
8x8E	4.2	---	0.9309	0.9312
8x8F	4.0	---	0.9396	0.9411

Note: The HI-STORM results are for internally dry (no moderator) HI-STORM storage casks with full water reflection on all sides, the HI-TRAC results are for internally fully flooded HI-TRAC transfer casks (which are part of the HI-STORM 100 System) with full water reflection on all sides, and the HI-STAR results are for unreflected, internally fully flooded HI-STAR casks.

[†] The term "maximum k_{eff} " as used here, and elsewhere in this document, means the highest possible k-effective, including bias, uncertainties, and calculational statistics, evaluated for the worst case combination of manufacturing tolerances.

^{††} This calculation was performed for 3.0% planar-average enrichment, however, the authorized contents are limited to a maximum planar-average enrichment of 2.7%. Therefore, the listed maximum k_{eff} value is conservative.

^{†††} This calculation was performed for a ^{10}B loading of 0.0067 g/cm², which is 75% of a minimum ^{10}B loading of 0.0089 g/cm². The minimum ^{10}B loading in the MPC-68 is at least 0.0310 g/cm². Therefore, the listed maximum k_{eff} value is conservative.

[‡] Assemblies in this class contain both MOX and UO₂ pins. The composition of the MOX fuel pins is given in Table 6.3.4. The maximum allowable planar-average enrichment for the MOX pins is given in the specification of authorized contents in Section 2.1.9.

HOLTEC INTERNATIONAL COPYRIGHTED MATERIAL

REPORT HI-2002444

6.1-15

Rev. 11

Table 6.1.7 (continued)

BOUNDING MAXIMUM k_{eff} VALUES FOR EACH ASSEMBLY CLASS IN THE MPC-68

Fuel Assembly Class	Maximum Allowable Planar-Average Enrichment (wt% ^{235}U)	Maximum [†] k_{eff}		
		HI-STORM	HI-TRAC	HI-STAR
9x9A	4.2	0.3365	0.9434	0.9417
9x9B	4.2	---	0.9417	0.9436
9x9C	4.2	---	0.9377	0.9395
9x9D	4.2	---	0.9387	0.9394
9x9E	4.0		0.9402	0.9401
9x9F	4.0	---	0.9402	0.9401
9x9G	4.2	---	0.9307	0.9309
10x10A	4.2	0.3379	0.9448 ^{††}	0.9457*
10x10B	4.2	---	0.9443	0.9436
10x10C	4.2	---	0.9430	0.9433
10x10D	4.0	---	0.9383	0.9376
10x10E	4.0	---	0.9157	0.9185

Note: The HI-STORM results are for internally dry (no moderator) HI-STORM storage casks with full water reflection on all sides, the HI-TRAC results are for internally fully flooded HI-TRAC transfer casks (which are part of the HI-STORM 100 System) with full water reflection on all sides, and the HI-STAR results are for unreflected, internally fully flooded HI-STAR casks.

[†] The term "maximum k_{eff} " as used here, and elsewhere in this document, means the highest possible k-effective, including bias, uncertainties, and calculational statistics, evaluated for the worst case combination of manufacturing tolerances.

^{††} KENO5a verification calculation resulted in a maximum k_{eff} of 0.9451.

* KENO5a verification calculation resulted in a maximum k_{eff} of 0.9453.

HOLTEC INTERNATIONAL COPYRIGHTED MATERIAL

REPORT HI-2002444

6.1-16

Rev. 11

HI-STORM 100-FSAR, NON-PROPRIETARY
REVISION 12
MARCH 12, 2014

Table 6.1.8

BOUNDING MAXIMUM k_{eff} VALUES FOR EACH ASSEMBLY CLASS IN THE MPC-68F

Fuel Assembly Class	Maximum Allowable Planar-Average Enrichment (wt% ^{235}U)	Maximum [†] k_{eff}		
		HI-STORM	HI-TRAC	HI-STAR
6x6A	2.7 ^{††}	---	0.7886	0.7888
6x6B ^{†††}	2.7	---	0.7833	0.7824
6x6C	2.7	0.2759	0.8024	0.8021
7x7A	2.7	---	0.7963	0.7974
8x8A	2.7	---	0.7690	0.7697

Notes:

1. The HI-STORM results are for internally dry (no moderator) HI-STORM storage casks with full water reflection on all sides, the HI-TRAC results are for internally fully flooded HI-TRAC transfer casks (which are part of the HI-STORM 100 System) with full water reflection on all sides, and the HI-STAR results are for unreflected, internally fully flooded HI-STAR casks.
2. These calculations were performed for a ^{10}B loading of 0.0067 g/cm^2 , which is 75% of a minimum ^{10}B loading of 0.0089 g/cm^2 . The minimum ^{10}B loading in the MPC-68F is 0.010 g/cm^2 . Therefore, the listed maximum k_{eff} values are conservative.

[†] The term "maximum k_{eff} " as used here, and elsewhere in this document, means the highest possible k-effective, including bias, uncertainties, and calculational statistics, evaluated for the worst case combination of manufacturing tolerances.

^{††} These calculations were performed for 3.0% planar-average enrichment, however, the authorized contents are limited to a maximum planar-average enrichment of 2.7%. Therefore, the listed maximum k_{eff} values are conservative.

^{†††} Assemblies in this class contain both MOX and UO_2 pins. The composition of the MOX fuel pins is given in Table 6.3.4. The maximum allowable planar-average enrichment for the MOX pins is specified in the specification of authorized contents in Section 2.1.9.

HOLTEC INTERNATIONAL COPYRIGHTED MATERIAL

Table 6.1.9

BOUNDING MAXIMUM k_{eff} VALUES FOR THE MPC-24E
WITH UP TO 4 DFCs

Fuel Assembly Class	Maximum Allowable Enrichment (wt% ^{235}U)		Minimum Soluble Boron Concentration (ppm)	Maximum k_{eff}	
	Intact Fuel	Damaged Fuel and Fuel Debris		HI-TRAC	HI-STAR
All PWR Classes	4.0	4.0	0	0.9486	0.9480
All PWR Classes [†]	5.0	5.0	600	0.9177	0.9185

Table 6.1.10

BOUNDING MAXIMUM k_{eff} VALUES FOR THE MPC-68 AND MPC-68F
WITH UP TO 68 DFCs

Fuel Assembly Class	Maximum Allowable Planar-Average Enrichment (wt% ^{235}U)		Maximum k_{eff}	
	Intact Fuel	Damaged Fuel and Fuel Debris	HI-TRAC	HI-STAR
6x6A, 6x6B, 6x6C, 7x7A, 8x8A	2.7	2.7	0.8024	0.8021

Table 6.1.11

BOUNDING MAXIMUM k_{eff} VALUES FOR THE MPC-68
WITH UP TO 16 DFCs

Fuel Assembly Class	Maximum Allowable Planar-Average Enrichment (wt% ^{235}U)		Maximum k_{eff}	
	Intact Fuel	Damaged Fuel and Fuel Debris	HI-TRAC	HI-STAR
All BWR Classes	3.7	4.0	0.9328	0.9328

[†] (Footnote deleted)

Table 6.1.12

BOUNDING MAXIMUM k_{eff} VALUES FOR THE MPC-32
WITH UP TO 8 DFCs

Fuel Assembly Class of Intact Fuel	Maximum Allowable Enrichment for Intact Fuel and Damaged Fuel/Fuel Debris (wt% ^{235}U)	Minimum Soluble Boron Content (ppm) [†]	Maximum k_{eff}	
			HI-TRAC	HI-STAR
14x14A, B, C, D, E	4.1	1500	---	0.9336
	5.0	2300	---	0.9269
15x15A, B, C, G, I	4.1	1900	0.9349	0.9350
	5.0	2700	---	0.9365
15x15D, E, F, H	4.1	2100	---	0.9340
	5.0	2900	0.9382	0.9397
16x16A	4.1	1500	---	0.9348
	5.0	2300	---	0.9299
17x17A, B, C	4.1	2100	---	0.9294
	5.0	2900	---	0.9367

[†] For maximum allowable enrichments between 4.1 wt% ^{235}U and 5.0 wt% ^{235}U , the minimum soluble boron concentration may be calculated by linear interpolation between the minimum soluble boron concentrations specified for each assembly class.

HOLTEC INTERNATIONAL COPYRIGHTED MATERIAL

REPORT HI-2002444

6.1-19

Rev. 11

6.2 SPENT FUEL LOADING

Specifications for the BWR and PWR fuel assemblies that were analyzed are given in Tables 6.2.1 and 6.2.2, respectively. For the BWR fuel characteristics, the number and dimensions for the water rods are the actual number and dimensions. For the PWR fuel characteristics, the actual number and dimensions of the control rod guide tubes and thimbles are used. Table 6.2.1 lists 72 unique BWR assemblies while Table 6.2.2 lists 47 unique PWR assemblies, all of which were explicitly analyzed for this evaluation. Examination of Tables 6.2.1 and 6.2.2 reveals that there are a large number of minor variations in fuel assembly dimensions.

Due to the large number of minor variations in the fuel assembly dimensions, the use of explicit dimensions in defining the authorized contents could limit the applicability of the HI-STORM 100 System. To resolve this limitation, bounding criticality analyses are presented in this section for a number of defined fuel assembly classes for both fuel types (PWR and BWR). The results of the bounding criticality analyses justify using bounding fuel dimensions for defining the authorized contents.

6.2.1 Definition of Assembly Classes

For each array size (e.g., 6x6, 7x7, 15x15, etc.), the fuel assemblies have been subdivided into a number of defined classes, where a class is defined in terms of (1) the number of fuel rods; (2) pitch; (3) number and locations of guide tubes (PWR) or water rods (BWR); and (4) cladding material. The assembly classes for BWR and PWR fuel are defined in Tables 6.2.1 and 6.2.2, respectively. It should be noted that these assembly classes are unique to this evaluation and are not known to be consistent with any class designations in the open literature.

For each assembly class, calculations have been performed for all of the dimensional variations for which data is available (i.e., all data in Tables 6.2.1 and 6.2.2). These calculations demonstrate that the maximum reactivity corresponds to:

- maximum active fuel length,
- maximum fuel pellet diameter,
- minimum cladding outside diameter (OD),
- maximum cladding inside diameter (ID),
- minimum guide tube/water rod thickness, and
- maximum channel thickness (for BWR assemblies only).

Therefore, for each assembly class, a bounding assembly was defined based on the above characteristics and a calculation for the bounding assembly was performed to demonstrate compliance with the regulatory requirement of $k_{\text{eff}} < 0.95$. In some assembly classes this bounding assembly corresponds directly to one of the actual (real) assemblies; while in most

HOLTEC INTERNATIONAL COPYRIGHTED MATERIAL

assembly classes, the bounding assembly is artificial (i.e., based on bounding dimensions from more than one of the actual assemblies). In classes where the bounding assembly is artificial, the reactivity of the actual (real) assemblies is typically much less than that of the bounding assembly; thereby providing additional conservatism. As a result of these analyses, the authorized contents in Section 2.1.9 are defined in terms of the bounding assembly parameters for each class.

To demonstrate that the aforementioned characteristics are bounding, a parametric study was performed for a reference BWR assembly, designated herein as 8x8C04 (identified generally as GE8x8R). Additionally, parametric studies were performed for a PWR assembly (the 15x15F assembly class) in the MPC-24 and MPC-32 with soluble boron in the water flooding the MPC. The results of these studies are shown in Table 6.2.3 through 6.2.5, and verify the positive reactivity effect associated with (1) increasing the pellet diameter, (2) maximizing the cladding ID (while maintaining a constant cladding OD), (3) minimizing the cladding OD (while maintaining a constant cladding ID), (4) decreasing the water rod/guide tube thickness, (5) artificially replacing the Zircaloy water rod tubes/guide tubes with water, (6) maximizing the channel thickness (for BWR Assemblies), and (7) increasing the active length. These results, and the many that follow, justify the approach for using bounding dimensions for defining the authorized contents. Where margins permit, the Zircaloy water rod tubes (BWR assemblies) are artificially replaced by water in the bounding cases to remove the requirement for water rod thickness from the specification of the authorized contents. As these studies were performed with and without soluble boron, they also demonstrate that the bounding dimensions are valid independent of the soluble boron concentration.

As mentioned, the bounding approach used in these analyses often results in a maximum k_{eff} value for a given class of assemblies that is much greater than the reactivity of any of the actual (real) assemblies within the class, and yet, is still below the 0.95 regulatory limit.

6.2.2 Intact PWR Fuel Assemblies

6.2.2.1 Intact PWR Fuel Assemblies in the MPC-24 without Soluble Boron

For PWR fuel assemblies (specifications listed in Table 6.2.2) the 15x15F01 fuel assembly at 4.1% enrichment has the highest reactivity (maximum k_{eff} of 0.9395). The 17x17A01 assembly (otherwise known as a Westinghouse 17x17 OFA) has a similar reactivity (see Table 6.2.20) and was used throughout this criticality evaluation as a reference PWR assembly. The 17x17A01 assembly is a representative PWR fuel assembly in terms of design and reactivity and is useful for the reactivity studies presented in Sections 6.3 and 6.4. Calculations for the various PWR fuel assemblies in the MPC-24 are summarized in Tables 6.2.6 through 6.2.22 for the fully flooded condition without soluble boron in the water.

HOLTEC INTERNATIONAL COPYRIGHTED MATERIAL

Tables 6.2.6 through 6.2.22 show the maximum k_{eff} values for the assembly classes that are acceptable for storage in the MPC-24. All maximum k_{eff} values include the bias, uncertainties, and calculational statistics, evaluated for the worst combination of manufacturing tolerances. All calculations for the MPC-24 were performed for a ^{10}B loading of 0.020 g/cm^2 , which is 75% of the minimum loading of 0.0267 g/cm^2 for Boral, or 90% of the minimum loading of 0.0223 g/cm^2 for Metamic. The maximum allowable enrichment in the MPC-24 varies from 3.8 to 5.0 wt% ^{235}U , depending on the assembly class, and is defined in Tables 6.2.6 through 6.2.22. It should be noted that the maximum allowable enrichment does not vary within an assembly class. Table 6.1.1 summarizes the maximum allowable enrichments for each of the assembly classes that are acceptable for storage in the MPC-24.

Tables 6.2.6 through 6.2.22 are formatted with the assembly class information in the top row, the unique assembly designations, dimensions, and k_{eff} values in the following rows above the bold double lines, and the bounding dimensions selected to define the authorized contents and corresponding bounding k_{eff} values in the final rows. Where the bounding assembly corresponds directly to one of the actual assemblies, the fuel assembly designation is listed in the bottom row in parentheses (e.g., Table 6.2.6). Otherwise, the bounding assembly is given a unique designation. For an assembly class that contains only a single assembly (e.g., 14x14D, see Table 6.2.9), the authorized contents dimensions are based on the assembly dimensions from that single assembly. All of the maximum k_{eff} values corresponding to the selected bounding dimensions are greater than or equal to those for the actual assembly dimensions and are below the 0.95 regulatory limit.

The results of the analyses for the MPC-24, which were performed for all assemblies in each class (see Tables 6.2.6 through 6.2.22), further confirm the validity of the bounding dimensions established in Section 6.2.1. Thus, for all following calculations, namely analyses of the MPC-24E, MPC-32, and MPC-24 with soluble boron present in the water, only the bounding assembly in each class is analyzed.

6.2.2.2 Intact PWR Fuel Assemblies in the MPC-24 with Soluble Boron

Additionally, the HI-STAR 100 system is designed to allow credit for the soluble boron typically present in the water of PWR spent fuel pools. For a minimum soluble boron concentration of 400ppm, the maximum allowable fuel enrichment is 5.0 wt% ^{235}U for all assembly classes identified in Tables 6.2.6 through 6.2.22. Table 6.1.2 shows the maximum k_{eff} for the bounding assembly in each assembly class. All maximum k_{eff} values are below the 0.95 regulatory limit. The 15x15H assembly class has the highest reactivity (maximum k_{eff} of 0.9366). The calculated k_{eff} and calculational uncertainty for each class is listed in Appendix 6.C.

6.2.2.3 Intact PWR Assemblies in the MPC-24E with and without Soluble Boron

The MPC-24E is a variation of the MPC-24, which provides for storage of higher enriched fuel than the MPC-24 through optimization of the storage cell layout. The MPC-24E also allows for the loading of up to 4 PWR Damaged Fuel Containers (DFC) with damaged PWR fuel and PWR fuel debris. The requirements for damaged fuel and fuel debris in the MPC-24E is discussed in Section 6.2.4.3.

Without credit for soluble boron, the maximum allowable fuel enrichment varies between 4.2 and 5.0 wt% ^{235}U , depending on the assembly classes as identified in Tables 6.2.6 through 6.2.22. The maximum allowable enrichment for each assembly class is listed in Table 6.1.3, together with the maximum k_{eff} for the bounding assembly in the assembly class. All maximum k_{eff} values are below the 0.95 regulatory limit. The 15x15F assembly class at 4.5% enrichment has the highest reactivity (maximum k_{eff} of 0.9468). The calculated k_{eff} and calculational uncertainty for each class is listed in Appendix 6.C.

For a minimum soluble boron concentration of 300ppm, the maximum allowable fuel enrichment is 5.0 wt% ^{235}U for all assembly classes identified in Tables 6.2.6 through 6.2.22. Table 6.1.4 shows the maximum k_{eff} for the bounding assembly in each assembly class. All maximum k_{eff} values are below the 0.95 regulatory limit. The 15x15H assembly class has the highest reactivity (maximum k_{eff} of 0.9399). The calculated k_{eff} and calculational uncertainty for each class is listed in Appendix 6.C.

6.2.2.4 Intact PWR Assemblies in the MPC-32

When loading any PWR fuel assembly in the MPC-32, a minimum soluble boron concentration is required.

For a maximum allowable fuel enrichment of 4.1 wt% ^{235}U for all assembly classes identified in Tables 6.2.6 through 6.2.22, a minimum soluble boron concentration between 1300ppm and 1900ppm is required, depending on the assembly class. Table 6.1.5 shows the maximum k_{eff} for the bounding assembly in each assembly class. All maximum k_{eff} values are below the 0.95 regulatory limit. The 16x16A assembly class has the highest reactivity (maximum k_{eff} of 0.9468). The calculated k_{eff} and calculational uncertainty for each class is listed in Appendix 6.C.

For a maximum allowable fuel enrichment of 5.0 wt% ^{235}U for all assembly classes identified in Tables 6.2.6 through 6.2.22, a minimum soluble boron concentration between 1900ppm and 2600ppm is required, depending on the assembly class. Table 6.1.6 shows the maximum k_{eff} for the bounding assembly in each assembly class. All maximum k_{eff} values are below the 0.95 regulatory limit. The 15x15F assembly class has the highest reactivity (maximum k_{eff} of 0.9483). The calculated k_{eff} and calculational uncertainty for each class is listed in Appendix 6.C.

HOLTEC INTERNATIONAL COPYRIGHTED MATERIAL

It is desirable to limit the soluble boron concentration to a level appropriate for the maximum enrichment in a basket, since this prevents adding soluble boron unnecessarily to the spent fuel pool during loading and unloading operations. This approach requires a minimum soluble boron level as a function of the maximum allowable enrichment, which can be directly derived by linear interpolation from the calculations at 4.1 wt% ^{235}U and 5.0 wt% ^{235}U shown in Tables 6.1.5 and 6.1.6. Since the maximum k_{eff} is a near linear function of both enrichment and soluble boron concentration, linear interpolation is both appropriate and sufficient. Further, studies have shown that this approach results in maximum k_{eff} values for enrichments between 4.1 wt% ^{235}U and 5.0 wt% ^{235}U that are lower than those maximum k_{eff} values calculated at 4.1 wt% and 5.0 wt% ^{235}U in Tables 6.1.5 and 6.1.6.

6.2.3 Intact BWR Fuel Assemblies in the MPC-68

For BWR fuel assemblies (specifications listed in Table 6.2.1) the artificial bounding assembly for the 10x10A assembly class at 4.2% enrichment has the highest reactivity (maximum k_{eff} of 0.9457). Calculations for the various BWR fuel assemblies in the MPC-68 are summarized in Tables 6.2.23 through 6.2.40 for the fully flooded condition. In all cases, the gadolinia (Gd_2O_3) normally incorporated in BWR fuel was conservatively neglected.

For calculations involving BWR assemblies, the use of a uniform (planar-average) enrichment, as opposed to the distributed enrichments normally used in BWR fuel, produces conservative results. Calculations confirming this statement are presented in Appendix 6.B for several representative BWR fuel assembly designs. These calculations justify the specification of planar-average enrichments to define acceptability of BWR fuel for loading into the MPC-68.

Tables 6.2.23 through 6.2.40 show the maximum k_{eff} values for assembly classes that are acceptable for storage in the MPC-68. All maximum k_{eff} values include the bias, uncertainties, and calculational statistics, evaluated for the worst combination of manufacturing tolerances. With the exception of assembly classes 6x6A, 6x6B, 6x6C, 7x7A, and 8x8A, which will be discussed in Section 6.2.4, all calculations for the MPC-68 were performed with a ^{10}B loading of 0.0279 g/cm^2 , which is 75% of the minimum loading of 0.0372 g/cm^2 for Boral, or 90% of the minimum loading of 0.031 g/cm^2 for Metamic. Calculations for assembly classes 6x6A, 6x6B, 6x6C, 7x7A, and 8x8A were conservatively performed with a ^{10}B loading of 0.0067 g/cm^2 . The maximum allowable enrichment in the MPC-68 varies from 2.7 to 4.2 wt% ^{235}U , depending on the assembly class. It should be noted that the maximum allowable enrichment does not vary within an assembly class. Table 6.1.7 summarizes the maximum allowable enrichments for all assembly classes that are acceptable for storage in the MPC-68.

Tables 6.2.23 through 6.2.40 are formatted with the assembly class information in the top row, the unique assembly designations, dimensions, and k_{eff} values in the following rows above the

HOLTEC INTERNATIONAL COPYRIGHTED MATERIAL

bold double lines, and the bounding dimensions selected to define the authorized contents and corresponding bounding k_{eff} values in the final rows. Where an assembly class contains only a single assembly (e.g., 8x8E, see Table 6.2.27), the authorized contents dimensions are based on the assembly dimensions from that single assembly. For assembly classes that are suspected to contain assemblies with thicker channels (e.g., 120 mils), bounding calculations are also performed to qualify the thicker channels (e.g. 7x7B, see Table 6.2.23). All of the maximum k_{eff} values corresponding to the selected bounding dimensions are shown to be greater than or equal to those for the actual assembly dimensions and are below the 0.95 regulatory limit.

For assembly classes that contain partial length rods (i.e., 9x9A, 10x10A, and 10x10B), calculations were performed for the actual (real) assembly configuration and for the axial segments (assumed to be full length) with and without the partial length rods. In all cases, the axial segment with only the full length rods present (where the partial length rods are absent) is bounding. Therefore, the bounding maximum k_{eff} values reported for assembly classes that contain partial length rods bound the reactivity regardless of the active fuel length of the partial length rods. As a result, the specification of the authorized contents has no minimum requirement for the active fuel length of the partial length rods.

For BWR fuel assembly classes where margins permit, the Zircaloy water rod tubes are artificially replaced by water in the bounding cases to remove the requirement for water rod thickness from the specification of the authorized contents. For these cases, the bounding water rod thickness is listed as zero.

As mentioned, the highest observed maximum k_{eff} value is 0.9457, corresponding to the artificial bounding assembly in the 10x10A assembly class. This assembly has the following bounding characteristics: (1) the partial length rods are assumed to be zero length (most reactive configuration); (2) the channel is assumed to be 120 mils thick; and (3) the active fuel length of the full length rods is 155 inches. Therefore, the maximum reactivity value is bounding compared to any of the real BWR assemblies listed.

6.2.4 BWR and PWR Damaged Fuel Assemblies and Fuel Debris

In addition to storing intact PWR and BWR fuel assemblies, the HI-STORM 100 System is designed to store BWR and PWR damaged fuel assemblies and fuel debris. Damaged fuel assemblies and fuel debris are defined in Table 1.0.1. Both damaged fuel assemblies and fuel debris are required to be loaded into Damaged Fuel Containers (DFCs)^[11]. Five different DFC types with different cross sections are considered; three types for BWR fuel and two for PWR fuel. DFCs containing BWR damaged fuel assemblies or fuel debris may be stored in the MPC-68 or MPC-68F. DFCs containing PWR damaged fuel or fuel debris may be stored in the MPC-24E or MPC-32. The criticality evaluation of various possible damaged conditions of the fuel is presented in Subsection 6.4.4.

HOLTEC INTERNATIONAL COPYRIGHTED MATERIAL

HI-STORM FSAR

Rev. 11

REPORT HI-2002444

6.2-6

6.2.4.1 Damaged BWR Fuel Assemblies and BWR Fuel Debris in Assembly Classes 6x6A, 6x6B, 6x6C, 7x7A and 8x8A

Tables 6.2.41 through 6.2.45 show the maximum k_{eff} values for the five assembly classes 6x6A, 6x6B, 6x6C, 7x7A and 8x8A. All maximum k_{eff} values include the bias, uncertainties, and calculational statistics, evaluated for the worst combination of manufacturing tolerances. All calculations were performed for a ^{10}B loading of 0.0067 g/cm^2 , which is 75% of a minimum loading, 0.0089 g/cm^2 . However, because the practical manufacturing lower limit for minimum ^{10}B loading is 0.01 g/cm^2 , the minimum ^{10}B loading of 0.01 g/cm^2 is specified on the drawing in Section 1.5, for the MPC-68F. As an additional level of conservatism in the analyses, the calculations were performed for an enrichment of 3.0 wt% ^{235}U , while the maximum allowable enrichment for these assembly classes is limited to 2.7 wt% ^{235}U in the specification of the authorized contents. Therefore, the maximum k_{eff} values for damaged BWR fuel assemblies and fuel debris are conservative. Calculations for the various BWR fuel assemblies in the MPC-68F are summarized in Tables 6.2.41 through 6.2.45 for the fully flooded condition.

For the assemblies that may be stored as damaged fuel or fuel debris, the 6x6C01 assembly at 3.0 wt% ^{235}U enrichment has the highest reactivity (maximum k_{eff} of 0.8021). Considering all of the conservatism built into this analysis (e.g., higher than allowed enrichment and lower than actual ^{10}B loading), the actual reactivity will be lower.

Because the analysis for the damaged BWR fuel assemblies and fuel debris was performed for a ^{10}B loading of 0.0089 g/cm^2 , which conservatively bounds the analysis of damaged BWR fuel assemblies in an MPC-68 with a minimum ^{10}B loading of 0.0372 g/cm^2 , damaged BWR fuel assemblies or fuel debris may be stored in the MPC-68 or MPC-68F.

Tables 6.2.41 through 6.2.45 are formatted with the assembly class information in the top row, the unique assembly designations, dimensions, and k_{eff} values in the following rows above the bold double lines, and the bounding dimensions selected to define the authorized contents and corresponding bounding k_{eff} values in the final rows. Where an assembly class contains only a single assembly (e.g., 6x6C, see Table 6.2.43), the authorized contents dimensions are based on the assembly dimensions from that single assembly. All of the maximum k_{eff} values corresponding to the selected bounding dimensions are greater than or equal to those for the actual assembly dimensions and are well below the 0.95 regulatory limit.

6.2.4.2 Damaged BWR Fuel Assemblies and Fuel Debris in the MPC-68

Damaged BWR fuel assemblies and fuel debris from all BWR classes may be loaded into the MPC-68 by restricting the locations of the DFCs to 16 specific cells on the periphery of the fuel basket. The MPC-68 may be loaded with up to 16 DFCs containing damaged fuel assemblies, with up to 8 DFCs containing fuel debris.

HOLTEC INTERNATIONAL COPYRIGHTED MATERIAL

HI-STORM FSAR

Rev. 11

REPORT HI-2002444

6.2-7

For all assembly classes, the enrichment of the damaged fuel or fuel debris is limited to a maximum of 4.0 wt% ^{235}U , while the enrichment of the intact assemblies stored together with the damaged fuel is limited to a maximum of 3.7 wt% ^{235}U . The maximum k_{eff} is 0.9328. The criticality evaluation of the damaged fuel assemblies and fuel debris in the MPC-68 is presented in Section 6.4.4.2.

6.2.4.3 Damaged PWR Fuel Assemblies and Fuel Debris

In addition to storing intact PWR fuel assemblies, the HI-STORM 100 System is designed to store damaged PWR fuel assemblies and fuel debris (MPC-24E and MPC-32). Damaged fuel assemblies and fuel debris are defined in Table 1.0.1. Damaged PWR fuel assemblies and fuel debris are required to be loaded into PWR Damaged Fuel Containers (DFCs).

6.2.4.3.1 Damaged PWR Fuel Assemblies and Fuel Debris in the MPC-24E

Up to four DFCs may be stored in the MPC-24E. When loaded with damaged fuel and/or fuel debris, the maximum enrichment for intact and damaged fuel is 4.0 wt% ^{235}U for all assembly classes listed in Table 6.2.6 through 6.2.22 without credit for soluble boron. The maximum k_{eff} for these classes is 0.9486. For a minimum soluble boron concentration of 600ppm, the maximum enrichment for intact and damaged fuel is 5.0 wt% ^{235}U for all assembly classes listed in Table 6.2.6 through 6.2.22. The criticality evaluation of the damaged fuel is presented in Subsection 6.4.4.2.

6.2.4.3.2 Damaged PWR Fuel Assemblies and Fuel Debris in the MPC-32

Up to eight DFCs may be stored in the MPC-32. For a maximum allowable fuel enrichment of 4.1 wt% ^{235}U for intact fuel, damaged fuel and fuel debris for all assembly classes identified in Tables 6.2.6 through 6.2.22, a minimum soluble boron concentration between 1500ppm and 2100ppm is required, depending on the assembly class of the intact assembly. For a maximum allowable fuel enrichment of 5.0 wt% ^{235}U for intact fuel, damaged fuel and fuel debris, a minimum soluble boron concentration between 2300ppm and 2900ppm is required, depending on the assembly class of the intact assembly. Table 6.1.12 shows the maximum k_{eff} by assembly class. All maximum k_{eff} values are below the 0.95 regulatory limit.

As discussed in Section 6.2.2.4, it is desirable to limit the soluble boron concentration to a level appropriate for the maximum enrichment in a basket. The discussion presented in Section 6.2.2.4 is also applicable for the MPC-32 with damaged fuel or fuel debris. Further, studies with damaged fuel have shown that this approach also results in maximum k_{eff} values that are lower than those k_{eff} values calculated for 4.1 wt% and 5.0 wt% ^{235}U in Table 6.1.12.

6.2.5 Thoria Rod Canister

Additionally, the HI-STORM 100 System is designed to store a Thoria Rod Canister in the MPC-68 or MPC-68F. The canister is similar to a DFC and contains 18 intact Thoria Rods placed in a separator assembly. The reactivity of the canister in the MPC is very low compared to the approved fuel assemblies (The ^{235}U content of these rods correspond to UO_2 rods with an initial enrichment of approximately 1.7 wt% ^{235}U). It is therefore permissible to the Thoria Rod Canister together with any approved content in a MPC-68 or MPC-68F. Specifications of the canister and the Thoria Rods that are used in the criticality evaluation are given in Table 6.2.46. The criticality evaluations are presented in Subsection 6.4.6.

HOLTEC INTERNATIONAL COPYRIGHTED MATERIAL

HI-STORM FSAR

Rev. 11

REPORT HI-2002444

6.2-9

HI-STORM 100 FSAR, NON-PROPRIETARY
REVISION 12
MARCH 12, 2014

Table 6.2.1 (page 1 of 7)
 BWR FUEL CHARACTERISTICS AND ASSEMBLY CLASS DEFINITIONS
 (all dimensions are in inches)

Fuel Assembly Designation	Clad Material	Pitch	Number of Fuel Rods	Cladding OD	Cladding Thickness	Pellet Diameter	Active Fuel Length	Number of Water Rods	Water Rod OD	Water Rod ID	Channel Thickness	Channel ID
6x6A Assembly Class												
6x6A01	Zr	0.694	36	0.5645	0.0350	0.4940	110.0	0	n/a	n/a	0.060	4.290
6x6A02	Zr	0.694	36	0.5645	0.0360	0.4820	110.0	0	n/a	n/a	0.060	4.290
6x6A03	Zr	0.694	36	0.5645	0.0350	0.4820	110.0	0	n/a	n/a	0.060	4.290
6x6A04	Zr	0.694	36	0.5550	0.0350	0.4820	110.0	0	n/a	n/a	0.060	4.290
6x6A05	Zr	0.696	36	0.5625	0.0350	0.4820	110.0	0	n/a	n/a	0.060	4.290
6x6A06	Zr	0.696	35	0.5625	0.0350	0.4820	110.0	1	0.0	0.0	0.060	4.290
6x6A07	Zr	0.700	36	0.5555	0.03525	0.4780	110.0	0	n/a	n/a	0.060	4.290
6x6A08	Zr	0.710	36	0.5625	0.0260	0.4980	110.0	0	n/a	n/a	0.060	4.290
6x6B (MOX) Assembly Class												
6x6B01	Zr	0.694	36	0.5645	0.0350	0.4820	110.0	0	n/a	n/a	0.060	4.290
6x6B02	Zr	0.694	36	0.5625	0.0350	0.4820	110.0	0	n/a	n/a	0.060	4.290
6x6B03	Zr	0.696	36	0.5625	0.0350	0.4820	110.0	0	n/a	n/a	0.060	4.290
6x6B04	Zr	0.696	35	0.5625	0.0350	0.4820	110.0	1	0.0	0.0	0.060	4.290
6x6B05	Zr	0.710	35	0.5625	0.0350	0.4820	110.0	1	0.0	0.0	0.060	4.290
6x6C Assembly Class												
6x6C01	Zr	0.740	36	0.5630	0.0320	0.4880	77.5	0	n/a	n/a	0.060	4.542
7x7A Assembly Class												
7x7A01	Zr	0.631	49	0.4860	0.0328	0.4110	80	0	n/a	n/a	0.060	4.542

HOLTEC INTERNATIONAL COPYRIGHTED MATERIAL

Table 6.2.1 (page 2 of 7)
 BWR FUEL CHARACTERISTICS AND ASSEMBLY CLASS DEFINITIONS
 (all dimensions are in inches)

Fuel Assembly Designation	Clad Material	Pitch	Number of Fuel Rods	Cladding OD	Cladding Thickness	Pellet Diameter	Active Fuel Length	Number of Water Rods	Water Rod OD	Water Rod ID	Channel Thickness	Channel ID
7x7B Assembly Class												
7x7B01	Zr	0.738	49	0.5630	0.0320	0.4870	150	0	n/a	n/a	0.080	5.278
7x7B02	Zr	0.738	49	0.5630	0.0370	0.4770	150	0	n/a	n/a	0.102	5.291
7x7B03	Zr	0.738	49	0.5630	0.0370	0.4770	150	0	n/a	n/a	0.080	5.278
7x7B04	Zr	0.738	49	0.5700	0.0355	0.4880	150	0	n/a	n/a	0.080	5.278
7x7B05	Zr	0.738	49	0.5630	0.0340	0.4775	150	0	n/a	n/a	0.080	5.278
7x7B06	Zr	0.738	49	0.5700	0.0355	0.4910	150	0	n/a	n/a	0.080	5.278
8x8A Assembly Class												
8x8A01	Zr	0.523	64	0.4120	0.0250	0.3580	110	0	n/a	n/a	0.100	4.290
8x8A02	Zr	0.523	63	0.4120	0.0250	0.3580	120	0	n/a	n/a	0.100	4.290

HOLTEC INTERNATIONAL COPYRIGHTED MATERIAL

Table 6.2.1 (page 3 of 7)
 BWR FUEL CHARACTERISTICS AND ASSEMBLY CLASS DEFINITIONS
 (all dimensions are in inches)

Fuel Assembly Designation	Clad Material	Pitch	Number of Fuel Rods	Cladding OD	Cladding Thickness	Pellet Diameter	Active Fuel Length	Number of Water Rods	Water Rod OD	Water Rod ID	Channel Thickness	Channel ID
8x8B Assembly Class												
8x8B01	Zr	0.641	63	0.4840	0.0350	0.4050	150	1	0.484	0.414	0.100	5.278
8x8B02	Zr	0.636	63	0.4840	0.0350	0.4050	150	1	0.484	0.414	0.100	5.278
8x8B03	Zr	0.640	63	0.4930	0.0340	0.4160	150	1	0.493	0.425	0.100	5.278
8x8B04	Zr	0.642	64	0.5015	0.0360	0.4195	150	0	n/a	n/a	0.100	5.278
8x8C Assembly Class												
8x8C01	Zr	0.641	62	0.4840	0.0350	0.4050	150	2	0.484	0.414	0.100	5.278
8x8C02	Zr	0.640	62	0.4830	0.0320	0.4100	150	2	0.591	0.531	0.000	no channel
8x8C03	Zr	0.640	62	0.4830	0.0320	0.4100	150	2	0.591	0.531	0.080	5.278
8x8C04	Zr	0.640	62	0.4830	0.0320	0.4100	150	2	0.591	0.531	0.100	5.278
8x8C05	Zr	0.640	62	0.4830	0.0320	0.4100	150	2	0.591	0.531	0.120	5.278
8x8C06	Zr	0.640	62	0.4830	0.0320	0.4110	150	2	0.591	0.531	0.100	5.278
8x8C07	Zr	0.640	62	0.4830	0.0340	0.4100	150	2	0.591	0.531	0.100	5.278
8x8C08	Zr	0.640	62	0.4830	0.0320	0.4100	150	2	0.493	0.425	0.100	5.278
8x8C09	Zr	0.640	62	0.4930	0.0340	0.4160	150	2	0.493	0.425	0.100	5.278
8x8C10	Zr	0.640	62	0.4830	0.0340	0.4100	150	2	0.591	0.531	0.120	5.278
8x8C11	Zr	0.640	62	0.4830	0.0340	0.4100	150	2	0.591	0.531	0.120	5.215
8x8C12	Zr	0.636	62	0.4830	0.0320	0.4110	150	2	0.591	0.531	0.120	5.215

HOLTEC INTERNATIONAL COPYRIGHTED MATERIAL

Table 6.2.1 (page 4 of 7)
 BWR FUEL CHARACTERISTICS AND ASSEMBLY CLASS DEFINITIONS
 (all dimensions are in inches)

Fuel Assembly Designation	Clad Material	Pitch	Number of Fuel Rods	Cladding OD	Cladding Thickness	Pellet Diameter	Active Fuel Length	Number of Water Rods	Water Rod OD	Water Rod ID	Channel Thickness	Channel ID
8x8D Assembly Class												
8x8D01	Zr	0.640	60	0.4830	0.0320	0.4110	150	2 large/ 2 small	0.591/0.483	0.531/0.433	0.100	5.278
8x8D02	Zr	0.640	60	0.4830	0.0320	0.4110	150	4	0.591	0.531	0.100	5.278
8x8D03	Zr	0.640	60	0.4830	0.0320	0.4110	150	4	0.483	0.433	0.100	5.278
8x8D04	Zr	0.640	60	0.4830	0.0320	0.4110	150	1	1.34	1.26	0.100	5.278
8x8D05	Zr	0.640	60	0.4830	0.0320	0.4100	150	1	1.34	1.26	0.100	5.278
8x8D06	Zr	0.640	60	0.4830	0.0320	0.4110	150	1	1.34	1.26	0.120	5.278
8x8D07	Zr	0.640	60	0.4830	0.0320	0.4110	150	1	1.34	1.26	0.080	5.278
8x8D08	Zr	0.640	61	0.4830	0.0300	0.4140	150	3	0.591	0.531	0.080	5.278
8x8E Assembly Class												
8x8E01	Zr	0.640	59	0.4930	0.0340	0.4160	150	5	0.493	0.425	0.100	5.278
8x8F Assembly Class												
8x8F01	Zr	0.609	64	0.4576	0.0290	0.3913	150	4 [†]	0.291 [†]	0.228 [†]	0.055	5.390
9x9A Assembly Class												
9x9A01	Zr	0.566	74	0.4400	0.0280	0.3760	150	2	0.98	0.92	0.100	5.278
9x9A02	Zr	0.566	66	0.4400	0.0280	0.3760	150	2	0.98	0.92	0.100	5.278
9x9A03	Zr	0.566	74/66	0.4400	0.0280	0.3760	150/90	2	0.98	0.92	0.100	5.278
9x9A04	Zr	0.566	66	0.4400	0.0280	0.3760	150	2	0.98	0.92	0.120	5.278

[†] Four rectangular water cross segments dividing the assembly into four quadrants

HOLTEC INTERNATIONAL COPYRIGHTED MATERIAL

HI-STORM FSAR
 REPORT HI-2002444

6.2-13

Rev. 11

Table 6.2.1 (page 5 of 7)
BWR FUEL CHARACTERISTICS AND ASSEMBLY CLASS DEFINITIONS
(all dimensions are in inches)

Fuel Assembly Designation	Clad Material	Pitch	Number of Fuel Rods	Cladding OD	Cladding Thickness	Pellet Diameter	Active Fuel Length	Number of Water Rods	Water Rod OD	Water Rod ID	Channel Thickness	Channel ID
9x9B Assembly Class												
9x9B01	Zr	0.569	72	0.4330	0.0262	0.3737	150	1	1.516	1.459	0.100	5.278
9x9B02	Zr	0.569	72	0.4330	0.0260	0.3737	150	1	1.516	1.459	0.100	5.278
9x9B03	Zr	0.572	72	0.4330	0.0260	0.3737	150	1	1.516	1.459	0.100	5.278
9x9C Assembly Class												
9x9C01	Zr	0.572	80	0.4230	0.0295	0.3565	150	1	0.512	0.472	0.100	5.278
9x9D Assembly Class												
9x9D01	Zr	0.572	79	0.4240	0.0300	0.3565	150	2	0.424	0.364	0.100	5.278
9x9E Assembly Class [†]												
9x9E01	Zr	0.572	76	0.4170	0.0265	0.3530	150	5	0.546	0.522	0.120	5.215
9x9E02	Zr	0.572	48 28	0.4170 0.4430	0.0265 0.0285	0.3530 0.3745	150	5	0.546	0.522	0.120	5.215

[†] The 9x9E and 9x9F fuel assembly classes represent a single fuel type containing fuel rods with different dimensions (SPC 9x9-5). In addition to the actual configuration (9x9E02 and 9x9F02), the 9x9E class contains a hypothetical assembly with only small fuel rods (9x9E01), and the 9x9F class contains a hypothetical assembly with only large rods (9x9F01). This was done in order to simplify the specification of this assembly in Section 2.1.9.

HOLTEC INTERNATIONAL COPYRIGHTED MATERIAL

Table 6.2.1 (page 6 of 7)
 BWR FUEL CHARACTERISTICS AND ASSEMBLY CLASS DEFINITIONS
 (all dimensions are in inches)

Fuel Assembly Designation	Clad Material	Pitch	Number of Fuel Rods	Cladding OD	Cladding Thickness	Pellet Diameter	Active Fuel Length	Number of Water Rods	Water Rod OD	Water Rod ID	Channel Thickness	Channel ID
9x9F Assembly Class *												
9x9F01	Zr	0.572	76	0.4430	0.0285	0.3745	150	5	0.546	0.522	0.120	5.215
9x9F02	Zr	0.572	48 28	0.4170 0.4430	0.0265 0.0285	0.3530 0.3745	150	5	0.546	0.522	0.120	5.215
9x9G Assembly Class												
9x9G01	Zr	0.572	72	0.4240	0.0300	0.3565	150	1	1.668	1.604	0.120	5.278
10x10A Assembly Class												
10x10A01	Zr	0.510	92	0.4040	0.0260	0.3450	155	2	0.980	0.920	0.100	5.278
10x10A02	Zr	0.510	78	0.4040	0.0260	0.3450	155	2	0.980	0.920	0.100	5.278
10x10A03	Zr	0.510	92/78	0.4040	0.0260	0.3450	155/90	2	0.980	0.920	0.100	5.278
10x10B Assembly Class												
10x10B01	Zr	0.510	91	0.3957	0.0239	0.3413	155	1	1.378	1.321	0.100	5.278
10x10B02	Zr	0.510	83	0.3957	0.0239	0.3413	155	1	1.378	1.321	0.100	5.278
10x10B03	Zr	0.510	91/83	0.3957	0.0239	0.3413	155/90	1	1.378	1.321	0.100	5.278

* The 9x9E and 9x9F fuel assembly classes represent a single fuel type containing fuel rods with different dimensions (SPC 9x9-5). In addition to the actual configuration (9x9E02 and 9x9F02), the 9x9E class contains a hypothetical assembly with only small fuel rods (9x9E01), and the 9x9F class contains a hypothetical assembly with only large rods (9x9F01). This was done in order to simplify the specification of this assembly in Section 2.1.9.

Table 6.2.1 (page 7 of 7)
 BWR FUEL CHARACTERISTICS AND ASSEMBLY CLASS DEFINITIONS
 (all dimensions are in inches)

Fuel Assembly Designation	Clad Material	Pitch	Number of Fuel Rods	Cladding OD	Cladding Thickness	Pellet Diameter	Active Fuel Length	Number of Water Rods	Water Rod OD	Water Rod ID	Channel Thickness	Channel ID
10x10C Assembly Class												
10x10C01	Zr	0.488	96	0.3780	0.0243	0.3224	150	5	1.227	1.165	0.055	5.347
10x10D Assembly Class												
10x10D01	SS	0.565	100	0.3960	0.0200	0.3500	83	0	n/a	n/a	0.08	5.663
10x10E Assembly Class												
10x10E01	SS	0.557	96	0.3940	0.0220	0.3430	83	4	0.3940	0.3500	0.08	5.663

HOLTEC INTERNATIONAL COPYRIGHTED MATERIAL

Table 6.2.2 (page 1 of 5)
PWR FUEL CHARACTERISTICS AND ASSEMBLY CLASS DEFINITIONS
(all dimensions are in inches)

Fuel Assembly Designation	Clad Material	Pitch	Number of Fuel Rods	Cladding OD	Cladding Thickness	Pellet Diameter	Active Fuel Length	Number of Guide Tubes	Guide Tube OD	Guide Tube ID	Guide Tube Thickness
14x14A Assembly Class											
14x14A01	Zr	0.556	179	0.400	0.0243	0.3444	150	17	0.527	0.493	0.0170
14x14A02	Zr	0.556	179	0.400	0.0243	0.3444	150	17	0.528	0.490	0.0190
14x14A03	Zr	0.556	179	0.400	0.0243	0.3444	150	17	0.526	0.492	0.0170
14x14B Assembly Class											
14x14B01	Zr	0.556	179	0.422	0.0243	0.3659	150	17	0.539	0.505	0.0170
14x14B02	Zr	0.556	179	0.417	0.0295	0.3505	150	17	0.541	0.507	0.0170
14x14B03	Zr	0.556	179	0.424	0.0300	0.3565	150	17	0.541	0.507	0.0170
14x14B04	Zr	0.556	179	0.426	0.0310	0.3565	150	17	0.541	0.507	0.0170
14x14C Assembly Class											
14x14C01	Zr	0.580	176	0.440	0.0280	0.3765	150	5	1.115	1.035	0.0400
14x14C02	Zr	0.580	176	0.440	0.0280	0.3770	150	5	1.115	1.035	0.0400
14x14C03	Zr	0.580	176	0.440	0.0260	0.3805	150	5	1.111	1.035	0.0380
14x14D Assembly Class											
14x14D01	SS	0.556	180	0.422	0.0165	0.3835	144	16	0.543	0.514	0.0145

HOLTEC INTERNATIONAL COPYRIGHTED MATERIAL

HI-STORM FSAR
REPORT HI-2002444

6.2-17

Rev. 11

Table 6.2.2 (page 2 of 5)
PWR FUEL CHARACTERISTICS AND ASSEMBLY CLASS DEFINITIONS
(all dimensions are in inches)

Fuel Assembly Designation	Clad Material	Pitch	Number of Fuel Rods	Cladding OD	Cladding Thickness	Pellet Diameter	Active Fuel Length	Number of Guide Tubes	Guide Tube OD	Guide Tube ID	Guide Tube Thickness
14x14E Assembly Class											
14x14E01 [†]	SS	0.453 and 0.441	162 3 8	0.3415 0.3415 0.3415	0.0120 0.0285 0.0200	0.313 0.280 0.297	102	0	n/a	n/a	n/a
14x14E02 [†]	SS	0.453 and 0.441	173	0.3415	0.0120	0.313	102	0	n/a	n/a	n/a
14x14E03 [†]	SS	0.453 and 0.441	173	0.3415	0.0285	0.0280	102	0	n/a	n/a	n/a
15x15A Assembly Class											
15x15A01	Zr	0.550	204	0.418	0.0260	0.3580	150	21	0.533	0.500	0.0165

[†] This is the fuel assembly used at Indian Point 1 (IP-1). This assembly is a 14x14 assembly with 23 fuel rods omitted to allow passage of control rods between assemblies. It has a different pitch in different sections of the assembly, and different fuel rod dimensions in some rods.

HOLTEC INTERNATIONAL COPYRIGHTED MATERIAL

Table 6.2.2 (page 3 of 5)
PWR FUEL CHARACTERISTICS AND ASSEMBLY CLASS DEFINITIONS
(all dimensions are in inches)

Fuel Assembly Designation	Clad Material	Pitch	Number of Fuel Rods	Cladding OD	Cladding Thickness	Pellet Diameter	Active Fuel Length	Number of Guide Tubes	Guide Tube OD	Guide Tube ID	Guide Tube Thickness
15x15B Assembly Class											
15x15B01	Zr	0.563	204	0.422	0.0245	0.3660	150	21	0.533	0.499	0.0170
15x15B02	Zr	0.563	204	0.422	0.0245	0.3660	150	21	0.546	0.512	0.0170
15x15B03	Zr	0.563	204	0.422	0.0243	0.3660	150	21	0.533	0.499	0.0170
15x15B04	Zr	0.563	204	0.422	0.0243	0.3659	150	21	0.545	0.515	0.0150
15x15B05	Zr	0.563	204	0.422	0.0242	0.3659	150	21	0.545	0.515	0.0150
15x15B06	Zr	0.563	204	0.420	0.0240	0.3671	150	21	0.544	0.514	0.0150
15x15C Assembly Class											
15x15C01	Zr	0.563	204	0.424	0.0300	0.3570	150	21	0.544	0.493	0.0255
15x15C02	Zr	0.563	204	0.424	0.0300	0.3570	150	21	0.544	0.511	0.0165
15x15C03	Zr	0.563	204	0.424	0.0300	0.3565	150	21	0.544	0.511	0.0165
15x15C04	Zr	0.563	204	0.417	0.0300	0.3565	150	21	0.544	0.511	0.0165
15x15D Assembly Class											
15x15D01	Zr	0.568	208	0.430	0.0265	0.3690	150	17	0.530	0.498	0.0160
15x15D02	Zr	0.568	208	0.430	0.0265	0.3686	150	17	0.530	0.498	0.0160
15x15D03	Zr	0.568	208	0.430	0.0265	0.3700	150	17	0.530	0.499	0.0155
15x15D04	Zr	0.568	208	0.430	0.0250	0.3735	150	17	0.530	0.500	0.0150
15x15E Assembly Class											
15x15E01	Zr	0.568	208	0.428	0.0245	0.3707	150	17	0.528	0.500	0.0140
15x15F Assembly Class											
15x15F01	Zr	0.568	208	0.428	0.0230	0.3742	150	17	0.528	0.500	0.0140

HOLTEC INTERNATIONAL COPYRIGHTED MATERIAL

Table 6.2.2 (page 4 of 5)
PWR FUEL CHARACTERISTICS AND ASSEMBLY CLASS DEFINITIONS
(all dimensions are in inches)

Fuel Assembly Designation	Clad Material	Pitch	Number of Fuel Rods	Cladding OD	Cladding Thickness	Pellet Diameter	Active Fuel Length	Number of Guide Tubes	Guide Tube OD	Guide Tube ID	Guide Tube Thickness
15x15G Assembly Class											
15x15G01	SS	0.563	204	0.422	0.0165	0.3825	144	21	0.543	0.514	0.0145
15x15H Assembly Class											
15x15H01	Zr	0.568	208	0.414	0.0220	0.3622	150	17	0.528	0.500	0.0140
15x15I Assembly Class											
15x15I01 [†]	Zr	0.550	216	0.413	0.0230	0.3600	150	9	n/a	n/a	0.0140
16x16A Assembly Class											
16x16A01	Zr	0.506	236	0.382	0.0250	0.3255	150	5	0.980	0.900	0.0400
16x16A02	Zr	0.506	236	0.382	0.0250	0.3250	150	5	0.980	0.900	0.0400
16x16A03	Zr	0.506	236	0.382	0.0235	0.3255	150	5	0.970	0.900	0.0350
17x17A Assembly Class											
17x17A01	Zr	0.496	264	0.360	0.0225	0.3088	150	25	0.474	0.442	0.0160
17x17A02	Zr	0.496	264	0.360	0.0250	0.3030	150	25	0.480	0.448	0.0160
17x17B Assembly Class											
17x17B01	Zr	0.496	264	0.374	0.0225	0.3225	150	25	0.482	0.450	0.0160
17x17B02	Zr	0.496	264	0.374	0.0225	0.3225	150	25	0.474	0.442	0.0160
17x17B03	Zr	0.496	264	0.376	0.0240	0.3215	150	25	0.480	0.448	0.0160
17x17B04	Zr	0.496	264	0.372	0.0205	0.3232	150	25	0.427	0.399	0.0140
17x17B05	Zr	0.496	264	0.374	0.0240	0.3195	150	25	0.482	0.450	0.0160
17x17B06	Zr	0.496	264	0.372	0.0205	0.3232	150	25	0.480	0.452	0.0140

[†] This assembly is a 15x15 assembly with 1 instrument tube and 8 guide bars (solid Zr) with outer diameter of 0.413 inches.

Table 6.2.2 (page 5 of 5)
PWR FUEL CHARACTERISTICS AND ASSEMBLY CLASS DEFINITIONS
(all dimensions are in inches)

Fuel Assembly Designation	Clad Material	Pitch	Number of Fuel Rods	Cladding OD	Cladding Thickness	Pellet Diameter	Active Fuel Length	Number of Guide Tubes	Guide Tube OD	Guide Tube ID	Guide Tube Thickness
17x17C Assembly Class											
17x17C01	Zr	0.502	264	0.379	0.0240	0.3232	150	25	0.472	0.432	0.0200
17x17C02	Zr	0.502	264	0.377	0.0220	0.3252	150	25	0.472	0.432	0.0200

HOLTEC INTERNATIONAL COPYRIGHTED MATERIAL

Table 6.2.3
 REACTIVITY EFFECT OF ASSEMBLY PARAMETER VARIATIONS for BWR Fuel in the MPC-68
 (all dimensions are in inches)

Fuel Assembly/ Parameter Variation	reactivity effect	calculated k_{eff}	standard deviation	cladding OD	cladding ID	cladding thickness	pellet OD	water rod thickness	channel thickness
8x8C04 (GE8x8R)	reference	0.9307	0.0007	0.483	0.419	0.032	0.410	0.030	0.100
increase pellet OD (+0.001)	+0.0005	0.9312	0.0007	0.483	0.419	0.032	0.411	0.030	0.100
decrease pellet OD (-0.001)	-0.0008	0.9299	0.0009	0.483	0.419	0.032	0.409	0.030	0.100
increase clad ID (+0.004)	+0.0027	0.9334	0.0007	0.483	0.423	0.030	0.410	0.030	0.100
decrease clad ID (-0.004)	-0.0034	0.9273	0.0007	0.483	0.415	0.034	0.410	0.030	0.100
increase clad OD (+0.004)	-0.0041	0.9266	0.0008	0.487	0.419	0.034	0.410	0.030	0.100
decrease clad OD (-0.004)	+0.0023	0.9330	0.0007	0.479	0.419	0.030	0.410	0.030	0.100
increase water rod thickness (+0.015)	-0.0019	0.9288	0.0008	0.483	0.419	0.032	0.410	0.045	0.100
decrease water rod thickness (-0.015)	+0.0001	0.9308	0.0008	0.483	0.419	0.032	0.410	0.015	0.100
remove water rods (i.e., replace the water rod tubes with water)	+0.0021	0.9328	0.0008	0.483	0.419	0.032	0.410	0.000	0.100
remove channel	-0.0039	0.9268	0.0009	0.483	0.419	0.032	0.410	0.030	0.000
increase channel thickness (+0.020)	+0.0005	0.9312	0.0007	0.483	0.419	0.032	0.410	0.030	0.120
reduced active length (120 Inches)	-0.0007	0.9300	0.0007	0.483	0.419	0.032	0.410	0.030	0.100
reduced active length (90 Inches)	-0.0043	0.9264	0.0007	0.483	0.419	0.032	0.410	0.030	0.100

HOLTEC INTERNATIONAL COPYRIGHTED MATERIAL

Table 6.2.4
 REACTIVITY EFFECT OF ASSEMBLY PARAMETER VARIATIONS in PWR Fuel in the MPC 24 with 400ppm soluble boron concentration
 (all dimensions are in inches)

Fuel Assembly/ Parameter Variation	reactivity effect	calculated k_{eff}	standard deviation	cladding OD	Cladding ID	cladding thickness	pellet OD	guide tube thickness
15x15F (15x15 B&W, 5.0% E)	reference	0.9271	0.0005	0.4280	0.3820	0.0230	0.3742	0.0140
increase pellet OD (+0.001)	-0.0008	0.9263	0.0004	0.4280	0.3820	0.0230	0.3752	0.0140
decrease pellet OD (-0.001)	-0.0002	0.9269	0.0005	0.4280	0.3820	0.0230	0.3732	0.0140
increase clad ID (+0.004)	+0.0040	0.9311	0.0005	0.4280	0.3860	0.0210	0.3742	0.0140
decrease clad ID (-0.004)	-0.0033	0.9238	0.0004	0.4280	0.3780	0.0250	0.3742	0.0140
increase clad OD (+0.004)	-0.0042	0.9229	0.0004	0.4320	0.3820	0.0250	0.3742	0.0140
decrease clad OD (-0.004)	+0.0035	0.9306	0.0005	0.4240	0.3820	0.0210	0.3742	0.0140
increase guide tube thickness (+0.004)	-0.0008	0.9263	0.0005	0.4280	0.3820	0.0230	0.3742	0.0180
decrease guide tube thickness (-0.004)	+0.0006	0.9277	0.0004	0.4280	0.3820	0.0230	0.3742	0.0100
remove guide tubes (i.e., replace the guide tubes with water)	+0.0028	0.9299	0.0004	0.4280	0.3820	0.0230	0.3742	0.000
voided guide tubes	-0.0318	0.8953	0.0005	0.4280	0.3820	0.0230	0.3742	0.0140

HOLTEC INTERNATIONAL COPYRIGHTED MATERIAL

Table 6.2.5
 REACTIVITY EFFECT OF ASSEMBLY PARAMETER VARIATIONS in PWR Fuel in the MPC-32 with 2600ppm soluble boron concentration
 (all dimensions are in inches)

Fuel Assembly/ Parameter Variation	reactivity effect	calculated k_{eff}	standard deviation	cladding OD	cladding ID	cladding thickness	pellet OD	guide tube thickness
15x15F (15x15 B&W, 5.0% E)	reference	0.9389	0.0004	0.4280	0.3820	0.0230	0.3742	0.0140
increase pellet OD (+0.001)	+0.0019	0.9408	0.0004	0.4280	0.3820	0.0230	0.3752	0.0140
decrease pellet OD (-0.001)	0.0000	0.9389	0.0004	0.4280	0.3820	0.0230	0.3732	0.0140
increase clad ID (+0.004)	+0.0015	0.9404	0.0004	0.4280	0.3860	0.0210	0.3742	0.0140
decrease clad ID (-0.004)	-0.0015	0.9374	0.0004	0.4280	0.3780	0.0250	0.3742	0.0140
increase clad OD (+0.004)	-0.0002	0.9387	0.0004	0.4320	0.3820	0.0250	0.3742	0.0140
decrease clad OD (-0.004)	+0.0007	0.9397	0.0004	0.4240	0.3820	0.0210	0.3742	0.0140
increase guide tube thickness (+0.004)	-0.0003	0.9387	0.0004	0.4280	0.3820	0.0230	0.3742	0.0180
decrease guide tube thickness (-0.004)	-0.0005	0.9384	0.0004	0.4280	0.3820	0.0230	0.3742	0.0100
remove guide tubes (i.e., replace the guide tubes with water)	-0.0005	0.9385	0.0004	0.4280	0.3820	0.0230	0.3742	0.000
voided guide tubes	+0.0039	0.9428	0.0004	0.4280	0.3820	0.0230	0.3742	0.0140

HOLTEC INTERNATIONAL COPYRIGHTED MATERIAL

Table 6.2. 6
 MAXIMUM K_{EFF} VALUES FOR THE 14X14A ASSEMBLY CLASS IN THE MPC-24
 (all dimensions are in inches)

14x14A (4.6% Enrichment, fixed neutron absorber ^{10}B minimum loading of 0.02 g/cm ²) 179 fuel rods, 17 guide tubes, pitch=0.556, Zr clad									
Fuel Assembly Designation	maximum k_{eff}	calculated k_{eff}	standard deviation	cladding OD	cladding ID	cladding thickness	pellet OD	fuel length	guide tube thickness
14x14A01	0.9295	0.9252	0.0008	0.400	0.3514	0.0243	0.3444	150	0.017
14x14A02	0.9286	0.9242	0.0008	0.400	0.3514	0.0243	0.3444	150	0.019
14x14A03	0.9296	0.9253	0.0008	0.400	0.3514	0.0243	0.3444	150	0.017
Dimensions Listed for Authorized Contents				0.400 (min.)	0.3514 (max.)		0.3444 (max.)	150 (max.)	0.017 (min.)
bounding dimensions (14x14A03)	0.9296	0.9253	0.0008	0.400	0.3514	0.0243	0.3444	150	0.017

HOLTEC INTERNATIONAL COPYRIGHTED MATERIAL

Table 6.2.7
 MAXIMUM K_{EFF} VALUES FOR THE 14X14B ASSEMBLY CLASS IN THE MPC-24
 (all dimensions are in inches)

14x14B (4.6% Enrichment, fixed neutron absorber ^{10}B minimum loading of 0.02 g/cm ²) 179 fuel rods, 17 guide tubes, pitch=0.556, Zr clad									
Fuel Assembly Designation	maximum k_{eff}	calculated k_{eff}	standard deviation	cladding OD	cladding ID	cladding thickness	pellet OD	fuel length	guide tube thickness
14x14B01	0.9159	0.9117	0.0007	0.422	0.3734	0.0243	0.3659	150	0.017
14x14B02	0.9169	0.9126	0.0008	0.417	0.3580	0.0295	0.3505	150	0.017
14x14B03	0.9110	0.9065	0.0009	0.424	0.3640	0.0300	0.3565	150	0.017
14x14B04	0.9084	0.9039	0.0009	0.426	0.3640	0.0310	0.3565	150	0.017
Dimensions Listed for Authorized Contents				0.417 (min.)	0.3734 (max.)		0.3659 (max.)	150 (max.)	0.017 (min.)
bounding dimensions (B14x14B01)	0.9228	0.9185	0.0008	0.417	0.3734	0.0218	0.3659	150	0.017

HOLTEC INTERNATIONAL COPYRIGHTED MATERIAL

Table 6.2.8
 MAXIMUM K_{EFF} VALUES FOR THE 14X14C ASSEMBLY CLASS IN THE MPC-24
 (all dimensions are in inches)

14x14C (4.6% Enrichment, fixed neutron absorber ^{10}B minimum loading of 0.02 g/cm ²) 176 fuel rods, 5 guide tubes, pitch=0.580, Zr clad									
Fuel Assembly Designation	maximum k_{eff}	calculated k_{eff}	standard deviation	cladding OD	Cladding ID	cladding thickness	pellet OD	fuel length	guide tube thickness
14x14C01	0.9258	0.9215	0.0008	0.440	0.3840	0.0280	0.3765	150	0.040
14x14C02	0.9265	0.9222	0.0008	0.440	0.3840	0.0280	0.3770	150	0.040
14x14C03	0.9287	0.9242	0.0009	0.440	0.3880	0.0260	0.3805	150	0.038
Dimensions Listed for Authorized Contents				0.440 (min.)	0.3880 (max.)		0.3805 (max.)	150 (max.)	0.038 (min.)
bounding dimensions (14x14C03)	0.9287	0.9242	0.0009	0.440	0.3880	0.0260	0.3805	150	0.038

HOLTEC INTERNATIONAL COPYRIGHTED MATERIAL

Table 6.2.9
 MAXIMUM K_{EFF} VALUES FOR THE 14X14D ASSEMBLY CLASS IN THE MPC-24
 (all dimensions are in inches)

14x14D (4.0% Enrichment, fixed neutron absorber ^{10}B minimum loading of 0.02 g/cm^2) 180 fuel rods, 16 guide tubes, pitch=0.556, SS clad									
Fuel Assembly Designation	maximum k_{eff}	calculated k_{eff}	standard deviation	cladding OD	Cladding ID	cladding thickness	pellet OD	fuel length	guide tube thickness
14x14D01	0.8507	0.8464	0.0008	0.422	0.3890	0.0165	0.3835	144	0.0145
Dimensions Listed for Authorized Contents				0.422 (min.)	0.3890 (max.)		0.3835 (max.)	144 (max.)	0.0145 (min.)

HOLTEC INTERNATIONAL COPYRIGHTED MATERIAL

Table 6.2.10
 MAXIMUM K_{EFF} VALUES FOR THE 14X14E ASSEMBLY CLASS IN THE MPC-24
 (all dimensions are in inches)

14x14E (5.0% Enrichment, fixed neutron absorber ^{10}B minimum loading of 0.02 g/cm ²) 173 fuel rods, 0 guide tubes, pitch=0.453 and 0.441, SS clad [†]									
Fuel Assembly Designation	maximum k_{eff}	calculated k_{eff}	standard deviation	cladding OD	cladding ID	cladding thickness	pellet OD	fuel length ^{††}	guide tube thickness
14x14E01	0.7598	0.7555	0.0008	0.3415	0.3175 0.2845 0.3015	0.0120 0.0285 0.0200	0.3130 0.2800 0.2970	102	0.0000
14x14E02	0.7627	0.7586	0.0007	0.3415	0.3175	0.0120	0.3130	102	0.0000
14x14E03	0.6952	0.6909	0.0008	0.3415	0.2845	0.0285	0.2800	102	0.0000
Dimensions Listed for Authorized Contents				0.3415 (min.)	0.3175 (max.)		0.3130 (max.)	102 (max.)	0.0000 (min.)
Bounding dimensions (14x14E02)	0.7627	0.7586	0.0007	0.3415	0.3175	0.0120	0.3130	102	0.0000

[†] This is the IP-1 fuel assembly at Indian Point. This assembly is a 14x14 assembly with 23 fuel rods omitted to allow passage of control rods between assemblies. Fuel rod dimensions are bounding for each of the three types of rods found in the IP-1 fuel assembly.

^{††} Calculations were conservatively performed for a fuel length of 150 inches.

HOLTEC INTERNATIONAL COPYRIGHTED MATERIAL

Table 6.2.11
 MAXIMUM K_{EFF} VALUES FOR THE 15X15A ASSEMBLY CLASS IN THE MPC-24
 (all dimensions are in inches)

15x15A (4.1% Enrichment, fixed neutron absorber ^{10}B minimum loading of 0.02 g/cm^2) 204 fuel rods, 21 guide tubes, pitch=0.550, Zr clad									
Fuel Assembly Designation	maximum k_{eff}	calculated k_{eff}	standard deviation	cladding OD	cladding ID	cladding thickness	pellet OD	fuel length	guide tube thickness
15x15A01	0.9204	0.9159	0.0009	0.418	0.3660	0.0260	0.3580	150	0.0165
Dimensions Listed for Authorized Contents				0.418 (min.)	0.3660 (max.)		0.3580 (max.)	150 (max.)	0.0165 (min.)

HOLTEC INTERNATIONAL COPYRIGHTED MATERIAL

Table 6.2.12
 MAXIMUM K_{EFF} VALUES FOR THE 15X15B ASSEMBLY CLASS IN THE MPC-24
 (all dimensions are in inches)

15x15B (4.1% Enrichment, fixed neutron absorber ^{10}B minimum loading of 0.02 g/cm ²) 204 fuel rods, 21 guide tubes, pitch=0.563, Zr clad									
Fuel Assembly Designation	maximum k_{eff}	calculated k_{eff}	standard deviation	cladding OD	cladding ID	cladding thickness	pellet OD	fuel length	guide tube thickness
15x15B01	0.9369	0.9326	0.0008	0.422	0.3730	0.0245	0.3660	150	0.017
15x15B02	0.9338	0.9295	0.0008	0.422	0.3730	0.0245	0.3660	150	0.017
15x15B03	0.9362	0.9318	0.0008	0.422	0.3734	0.0243	0.3660	150	0.017
15x15B04	0.9370	0.9327	0.0008	0.422	0.3734	0.0243	0.3659	150	0.015
15x15B05	0.9356	0.9313	0.0008	0.422	0.3736	0.0242	0.3659	150	0.015
15x15B06	0.9366	0.9324	0.0007	0.420	0.3720	0.0240	0.3671	150	0.015
Dimensions Listed for Authorized Contents				0.420 (min.)	0.3736 (max.)		0.3671 (max.)	150 (max.)	0.015 (min.)
bounding dimensions (B15x15B01)	0.9388	0.9343	0.0009	0.420	0.3736	0.0232	0.3671	150	0.015

HOLTEC INTERNATIONAL COPYRIGHTED MATERIAL

Table 6.2.13
 MAXIMUM K_{EFF} VALUES FOR THE 15X15C ASSEMBLY CLASS IN THE MPC-24
 (all dimensions are in inches)

15x15C (4.1% Enrichment, fixed neutron absorber ^{10}B minimum loading of 0.02 g/cm ²) 204 fuel rods, 21 guide tubes, pitch=0.563, Zr clad									
Fuel Assembly Designation	maximum k_{eff}	calculated k_{eff}	standard deviation	cladding OD	cladding ID	cladding thickness	pellet OD	fuel length	guide tube thickness
15x15C01	0.9255	0.9213	0.0007	0.424	0.3640	0.0300	0.3570	150	0.0255
15x15C02	0.9297	0.9255	0.0007	0.424	0.3640	0.0300	0.3570	150	0.0165
15x15C03	0.9297	0.9255	0.0007	0.424	0.3640	0.0300	0.3565	150	0.0165
15x15C04	0.9311	0.9268	0.0008	0.417	0.3570	0.0300	0.3565	150	0.0165
Dimensions Listed for Authorized Contents				0.417 (min.)	0.3640 (max.)		0.3570 (max.)	150 (max.)	0.0165 (min.)
bounding dimensions (B15x15C01)	0.9361	0.9316	0.0009	0.417	0.3640	0.0265	0.3570	150	0.0165

HOLTEC INTERNATIONAL COPYRIGHTED MATERIAL

Table 6.2.14
 MAXIMUM K_{EFF} VALUES FOR THE 15X15D ASSEMBLY CLASS IN THE MPC-24
 (all dimensions are in inches)

15x15D (4.1% Enrichment, fixed neutron absorber ^{10}B minimum loading of 0.02 g/cm ²) 208 fuel rods, 17 guide tubes, pitch=0.568, Zr clad									
Fuel Assembly Designation	maximum k_{eff}	calculated k_{eff}	standard deviation	cladding OD	cladding ID	cladding thickness	pellet OD	fuel length	guide tube thickness
15x15D01	0.9341	0.9298	0.0008	0.430	0.3770	0.0265	0.3690	150	0.0160
15x15D02	0.9367	0.9324	0.0008	0.430	0.3770	0.0265	0.3686	150	0.0160
15x15D03	0.9354	0.9311	0.0008	0.430	0.3770	0.0265	0.3700	150	0.0155
15x15D04	0.9339	0.9292	0.0010	0.430	0.3800	0.0250	0.3735	150	0.0150
Dimensions Listed for Authorized Contents				0.430 (min.)	0.3800 (max.)		0.3735 (max.)	150 (max.)	0.0150 (min.)
bounding dimensions (15x15D04)	0.9339 [†]	0.9292	0.0010	0.430	0.3800	0.0250	0.3735	150	0.0150

[†] The k_{eff} value listed for the 15x15D02 case is higher than that for the case with the bounding dimensions. Therefore, the 0.9367 (15x15D02) value is listed in Table 6.1.1 as the maximum.

Table 6.2.15
 MAXIMUM K_{EFF} VALUES FOR THE 15X15E ASSEMBLY CLASS IN THE MPC-24
 (all dimensions are in inches)

15x15E (4.1% Enrichment, fixed neutron absorber ^{10}B minimum loading of 0.02 g/cm ²) 208 fuel rods, 17 guide tubes, pitch=0.568, Zr clad									
Fuel Assembly Designation	maximum k_{eff}	calculated k_{eff}	standard deviation	cladding OD	cladding ID	cladding thickness	pellet OD	fuel length	guide tube thickness
15x15E01	0.9368	0.9325	0.0008	0.428	0.3790	0.0245	0.3707	150	0.0140
Dimensions Listed for Authorized Contents				0.428 (min.)	0.3790 (max.)		0.3707 (max.)	150 (max.)	0.0140 (min.)

HOLTEC INTERNATIONAL COPYRIGHTED MATERIAL

Table 6.2.16
 MAXIMUM K_{EFF} VALUES FOR THE 15X15F ASSEMBLY CLASS IN THE MPC-24
 (all dimensions are in inches)

15x15F (4.1% Enrichment, fixed neutron absorber ^{10}B minimum loading of 0.02 g/cm ²) 208 fuel rods, 17 guide tubes, pitch=0.568, Zr clad									
Fuel Assembly Designation	maximum k_{eff}	calculated k_{eff}	standard deviation	cladding OD	cladding ID	cladding thickness	pellet OD	fuel length	guide tube thickness
15x15F01	0.9395 [†]	0.9350	0.0009	0.428	0.3820	0.0230	0.3742	150	0.0140
Dimensions Listed for Authorized Contents				0.428 (min.)	0.3820 (max.)		0.3742 (max.)	150 (max.)	0.0140 (min.)

[†] KENO5a verification calculation resulted in a maximum k_{eff} of 0.9383.

Table 6.2.17
 MAXIMUM K_{EFF} VALUES FOR THE 15X15G ASSEMBLY CLASS IN THE MPC-24
 (all dimensions are in inches)

15x15G (4.0% Enrichment, fixed neutron absorber ^{10}B minimum loading of 0.02 g/cm ²) 204 fuel rods, 21 guide tubes, pitch=0.563, SS clad									
Fuel Assembly Designation	maximum k_{eff}	calculated k_{eff}	standard deviation	cladding OD	cladding ID	cladding thickness	pellet OD	fuel length	guide tube thickness
15x15G01	0.8876	0.8833	0.0008	0.422	0.3890	0.0165	0.3825	144	0.0145
Dimensions Listed for Authorized Contents				0.422 (min.)	0.3890 (max.)		0.3825 (max.)	144 (max.)	0.0145 (min.)

HOLTEC INTERNATIONAL COPYRIGHTED MATERIAL

Table 6.2.18
 MAXIMUM K_{EFF} VALUES FOR THE 15X15H ASSEMBLY CLASS IN THE MPC-24
 (all dimensions are in inches)

15x15H (3.8% Enrichment, fixed neutron absorber ^{10}B minimum loading of 0.02 g/cm ²) 208 fuel rods, 17 guide tubes, pitch=0.568, Zr clad									
Fuel Assembly Designation	maximum k_{eff}	calculated k_{eff}	standard deviation	cladding OD	cladding ID	cladding thickness	pellet OD	fuel length	guide tube thickness
15x15H01	0.9337	0.9292	0.0009	0.414	0.3700	0.0220	0.3622	150	0.0140
Dimensions Listed for Authorized Contents				0.414 (min.)	0.3700 (max.)		0.3622 (max.)	150 (max.)	0.0140 (min.)

HOLTEC INTERNATIONAL COPYRIGHTED MATERIAL

Table 6.2.19
 MAXIMUM K_{EFF} VALUES FOR THE 16X16A ASSEMBLY CLASS IN THE MPC-24
 (all dimensions are in inches)

16x16A (4.6% Enrichment, fixed neutron absorber ^{10}B minimum loading of 0.02 g/cm ²) 236 fuel rods, 5 guide tubes, pitch=0.506, Zr clad									
Fuel Assembly Designation	maximum k_{eff}	calculated k_{eff}	standard deviation	cladding OD	cladding ID	cladding thickness	pellet OD	fuel length	guide tube thickness
16x16A01	0.9287	0.9244	0.0008	0.382	0.3320	0.0250	0.3255	150	0.0400
16x16A02	0.9263	0.9221	0.0007	0.382	0.3320	0.0250	0.3250	150	0.0400
16x16A03	0.9327	0.9282	0.0009	0.382	0.3350	0.0235	0.3255	150	0.0350
Dimensions Listed for Authorized Contents				0.382 (min.)	0.3350 (max.)		0.3255 (max.)	150 (max.)	0.0350 (min.)
bounding dimensions (16x16A03)	0.9327	0.9282	0.0009	0.382	0.3350	0.0235	0.3255	150	0.0350

HOLTEC INTERNATIONAL COPYRIGHTED MATERIAL

Table 6.2.20
 MAXIMUM K_{EFF} VALUES FOR THE 17X17A ASSEMBLY CLASS IN THE MPC-24
 (all dimensions are in inches)

17x17A (4.0% Enrichment, fixed neutron absorber ^{10}B minimum loading of 0.02 g/cm ²) 264 fuel rods, 25 guide tubes, pitch=0.496, Zr clad									
Fuel Assembly Designation	maximum k_{eff}	calculated k_{eff}	standard deviation	cladding OD	cladding ID	cladding thickness	pellet OD	fuel length	guide tube thickness
17x17A01	0.9368	0.9325	0.0008	0.360	0.3150	0.0225	0.3088	150	0.016
17x17A02	0.9329	0.9286	0.0008	0.360	0.3100	0.0250	0.3030	150	0.016
Dimensions Listed for Authorized Contents				0.360 (min.)	0.3150 (max.)		0.3088 (max.)	150 (max.)	0.016 (min.)
bounding dimensions (17x17A01)	0.9368	0.9325	0.0008	0.360	0.3150	0.0225	0.3088	150	0.016

HOLTEC INTERNATIONAL COPYRIGHTED MATERIAL

Table 6.2.21
 MAXIMUM k_{EFF} VALUES FOR THE 17X17B ASSEMBLY CLASS IN THE MPC-24
 (all dimensions are in inches)

17x17B (4.0% Enrichment, fixed neutron absorber ^{10}B minimum loading of 0.02 g/cm ²) 264 fuel rods, 25 guide tubes, pitch=0.496, Zr clad									
Fuel Assembly Designation	maximum k_{eff}	calculated k_{eff}	standard deviation	Cladding OD	cladding ID	cladding thickness	pellet OD	fuel length	guide tube thickness
17x17B01	0.9288	0.9243	0.0009	0.374	0.3290	0.0225	0.3225	150	0.016
17x17B02	0.9290	0.9247	0.0008	0.374	0.3290	0.0225	0.3225	150	0.016
17x17B03	0.9243	0.9199	0.0008	0.376	0.3280	0.0240	0.3215	150	0.016
17x17B04	0.9324	0.9279	0.0009	0.372	0.3310	0.0205	0.3232	150	0.014
17x17B05	0.9266	0.9222	0.0008	0.374	0.3260	0.0240	0.3195	150	0.016
17x17B06	0.9311	0.9268	0.0008	0.372	0.3310	0.0205	0.3232	150	0.014
Dimensions Listed for Authorized Contents				0.372 (min.)	0.3310 (max.)		0.3232 (max.)	150 (max.)	0.014 (min.)
bounding dimensions (17x17B06)	0.9311 [†]	0.9268	0.0008	0.372	0.3310	0.0205	0.3232	150	0.014

[†] The k_{eff} value listed for the 17x17B04 case is higher than that for the case with the bounding dimensions. Therefore, the 0.9324 (17x17B04) value is listed in Table 6.1.1 as the maximum.

Table 6.2.22
 MAXIMUM K_{EFF} VALUES FOR THE 17X17C ASSEMBLY CLASS IN THE MPC-24
 (all dimensions are in inches)

17x17C (4.0% Enrichment, fixed neutron absorber ^{10}B minimum loading of 0.02 g/cm ²) 264 fuel rods, 25 guide tubes, pitch=0.502, Zr clad									
Fuel Assembly Designation	maximum k_{eff}	calculated k_{eff}	standard deviation	cladding OD	cladding ID	cladding thickness	pellet OD	fuel length	guide tube thickness
17x17C01	0.9293	0.9250	0.0008	0.379	0.3310	0.0240	0.3232	150	0.020
17x17C02	0.9336	0.9293	0.0008	0.377	0.3330	0.0220	0.3252	150	0.020
Dimensions Listed for Authorized Contents				0.377 (min.)	0.3330 (max.)		0.3252 (max.)	150 (max.)	0.020 (min.)
bounding dimensions (17x17C02)	0.9336	0.9293	0.0008	0.377	0.3330	0.0220	0.3252	150	0.020

HOLTEC INTERNATIONAL COPYRIGHTED MATERIAL

Table 6.2.23
 MAXIMUM K_{EFF} VALUES FOR THE 7X7B ASSEMBLY CLASS IN THE MPC-68
 (all dimensions are in inches)

7x7B (4.2% Enrichment, fixed neutron absorber ^{10}B minimum loading of 0.0279 g/cm ²) 49 fuel rods, 0 water rods, pitch=0.738, Zr clad										
Fuel Assembly Designation	maximum k_{eff}	calculated k_{eff}	standard deviation	cladding OD	cladding ID	cladding thickness	pellet OD	fuel length	water rod thickness	channel thickness
7x7B01	0.9372	0.9330	0.0007	0.5630	0.4990	0.0320	0.4870	150	n/a	0.080
7x7B02	0.9301	0.9260	0.0007	0.5630	0.4890	0.0370	0.4770	150	n/a	0.102
7x7B03	0.9313	0.9271	0.0008	0.5630	0.4890	0.0370	0.4770	150	n/a	0.080
7x7B04	0.9311	0.9270	0.0007	0.5700	0.4990	0.0355	0.4880	150	n/a	0.080
7x7B05	0.9350	0.9306	0.0008	0.5630	0.4950	0.0340	0.4775	150	n/a	0.080
7x7B06	0.9298	0.9260	0.0006	0.5700	0.4990	0.0355	0.4910	150	n/a	0.080
Dimensions Listed for Authorized Contents				0.5630 (min.)	0.4990 (max.)		0.4910 (max.)	150 (max.)	n/a	0.120 (max.)
bounding dimensions (B7x7B01)	0.9375	0.9332	0.0008	0.5630	0.4990	0.0320	0.4910	150	n/a	0.102
bounding dimensions with 120 mil channel (B7x7B02)	0.9386	0.9344	0.0007	0.5630	0.4990	0.0320	0.4910	150	n/a	0.120

HOLTEC INTERNATIONAL COPYRIGHTED MATERIAL

Table 6.2.24
 MAXIMUM K_{EFF} VALUES FOR THE 8X8B ASSEMBLY CLASS IN THE MPC-68
 (all dimensions are in inches)

8x8B (4.2% Enrichment, fixed neutron absorber ^{10}B minimum loading of 0.0279 g/cm ²) 63 or 64 fuel rods [†] , 1 or 0 water rods [†] , pitch [†] = 0.636-0.642, Zr clad												
Fuel Assembly Designation	maximum k_{eff}	calculated k_{eff}	standard deviation	Fuel rods	Pitch	cladding OD	cladding ID	cladding thickness	pellet OD	fuel length	water rod thickness	channel thickness
8x8B01	0.9310	0.9265	0.0009	63	0.641	0.4840	0.4140	0.0350	0.4050	150	0.035	0.100
8x8B02	0.9227	0.9185	0.0007	63	0.636	0.4840	0.4140	0.0350	0.4050	150	0.035	0.100
8x8B03	0.9299	0.9257	0.0008	63	0.640	0.4930	0.4250	0.0340	0.4160	150	0.034	0.100
8x8B04	0.9236	0.9194	0.0008	64	0.642	0.5015	0.4295	0.0360	0.4195	150	n/a	0.100
Dimensions Listed for Authorized Contents				63 or 64	0.636-0.642	0.4840 (min.)	0.4295 (max.)		0.4195 (max.)	150 (max.)	0.034	0.120 (max.)
bounding (pitch=0.636) (B8x8B01)	0.9346	0.9301	0.0009	63	0.636	0.4840	0.4295	0.02725	0.4195	150	0.034	0.120
bounding (pitch=0.640) (B8x8B02)	0.9385	0.9343	0.0008	63	0.640	0.4840	0.4295	0.02725	0.4195	150	0.034	0.120
bounding (pitch=0.642) (B8x8B03)	0.9416	0.9375	0.0007	63	0.642	0.4840	0.4295	0.02725	0.4195	150	0.034	0.120

[†] This assembly class was analyzed and qualified for a small variation in the pitch and a variation in the number of fuel and water rods.

Table 6.2.25
 MAXIMUM k_{EFF} VALUES FOR THE 8X8C ASSEMBLY CLASS IN THE MPC-68
 (all dimensions are in inches)

8x8C (4.2% Enrichment, fixed neutron absorber ^{10}B minimum loading of 0.0279 g/cm ²)											
62 fuel rods, 2 water rods, pitch [†] = 0.636-0.641, Zr clad											
Fuel Assembly Designation	maximum k_{eff}	calculated k_{eff}	standard deviation	pitch	cladding OD	cladding ID	cladding thickness	pellet OD	fuel length	water rod thickness	channel thickness
8x8C01	0.9315	0.9273	0.0007	0.641	0.4840	0.4140	0.0350	0.4050	150	0.035	0.100
8x8C02	0.9313	0.9268	0.0009	0.640	0.4830	0.4190	0.0320	0.4100	150	0.030	0.000
8x8C03	0.9329	0.9286	0.0008	0.640	0.4830	0.4190	0.0320	0.4100	150	0.030	0.800
8x8C04	0.9348 ^{††}	0.9307	0.0007	0.640	0.4830	0.4190	0.0320	0.4100	150	0.030	0.100
8x8C05	0.9353	0.9312	0.0007	0.640	0.4830	0.4190	0.0320	0.4100	150	0.030	0.120
8x8C06	0.9353	0.9312	0.0007	0.640	0.4830	0.4190	0.0320	0.4110	150	0.030	0.100
8x8C07	0.9314	0.9273	0.0007	0.640	0.4830	0.4150	0.0340	0.4100	150	0.030	0.100
8x8C08	0.9339	0.9298	0.0007	0.640	0.4830	0.4190	0.0320	0.4100	150	0.034	0.100
8x8C09	0.9301	0.9260	0.0007	0.640	0.4930	0.4250	0.0340	0.4160	150	0.034	0.100
8x8C10	0.9317	0.9275	0.0008	0.640	0.4830	0.4150	0.0340	0.4100	150	0.030	0.120
8x8C11	0.9328	0.9287	0.0007	0.640	0.4830	0.4150	0.0340	0.4100	150	0.030	0.120
8x8C12	0.9285	0.9242	0.0008	0.636	0.4830	0.4190	0.0320	0.4110	150	0.030	0.120
Dimensions Listed for Authorized Contents				0.636-0.641	0.4830 (min.)	0.4250 (max.)		0.4160 (max.)	150 (max.)	0.000 (min.)	0.120 (max.)
bounding (pitch=0.636) (B8x8C01)	0.9357	0.9313	0.0009	0.636	0.4830	0.4250	0.0290	0.4160	150	0.000	0.120
bounding (pitch=0.640) (B8x8C02)	0.9425	0.9384	0.0007	0.640	0.4830	0.4250	0.0290	0.4160	150	0.000	0.120
Bounding (pitch=0.641) (B8x8C03)	0.9418	0.9375	0.0008	0.641	0.4830	0.4250	0.0290	0.4160	150	0.000	0.120

[†] This assembly class was analyzed and qualified for a small variation in the pitch.

^{††} KENO5a verification calculation resulted in a maximum k_{eff} of 0.9343.

Table 6.2.26
 MAXIMUM K_{EFF} VALUES FOR THE 8X8D ASSEMBLY CLASS IN THE MPC-68
 (all dimensions are in inches)

8x8D (4.2% Enrichment, fixed neutron absorber ^{10}B minimum loading of 0.0279 g/cm ²) 60-61 fuel rods, 1-4 water rods [†] , pitch=0.640, Zr clad										
Fuel Assembly Designation	maximum k_{eff}	calculated k_{eff}	standard deviation	Cladding OD	cladding ID	cladding thickness	pellet OD	fuel length	water rod thickness	channel thickness
8x8D01	0.9342	0.9302	0.0006	0.4830	0.4190	0.0320	0.4110	150	0.03/0.025	0.100
8x8D02	0.9325	0.9284	0.0007	0.4830	0.4190	0.0320	0.4110	150	0.030	0.100
8x8D03	0.9351	0.9309	0.0008	0.4830	0.4190	0.0320	0.4110	150	0.025	0.100
8x8D04	0.9338	0.9296	0.0007	0.4830	0.4190	0.0320	0.4110	150	0.040	0.100
8x8D05	0.9339	0.9294	0.0009	0.4830	0.4190	0.0320	0.4100	150	0.040	0.100
8x8D06	0.9365	0.9324	0.0007	0.4830	0.4190	0.0320	0.4110	150	0.040	0.120
8x8D07	0.9341	0.9297	0.0009	0.4830	0.4190	0.0320	0.4110	150	0.040	0.080
8x8D08	0.9376	0.9332	0.0009	0.4830	0.4230	0.0300	0.4140	150	0.030	0.080
Dimensions Listed for Authorized Contents				0.4830 (min.)	0.4230 (max.)		0.4140 (max.)	150 (max.)	0.000 (min.)	0.120 (max.)
bounding dimensions (B8x8D01)	0.9403	0.9363	0.0007	0.4830	0.4230	0.0300	0.4140	150	0.000	0.120

[†] Fuel assemblies 8x8D01 through 8x8D03 have 4 water rods that are similar in size to the fuel rods, while assemblies 8x8D04 through 8x8D07 have 1 large water rod that takes the place of the 4 water rods. Fuel assembly 8x8D08 contains 3 water rods that are similar in size to the fuel rods.

HOLTEC INTERNATIONAL COPYRIGHTED MATERIAL

Table 6.2.27
 MAXIMUM K_{EFF} VALUES FOR THE 8X8E ASSEMBLY CLASS IN THE MPC-68
 (all dimensions are in inches)

8x8E (4.2% Enrichment, fixed neutron absorber ^{10}B minimum loading of 0.0279 g/cm ²) 59 fuel rods, 5 water rods, pitch=0.640, Zr clad										
Fuel Assembly Designation	maximum k_{eff}	calculated k_{eff}	standard deviation	cladding OD	cladding ID	cladding thickness	pellet OD	fuel length	water rod thickness	channel thickness
8x8E01	0.9312	0.9270	0.0008	0.4930	0.4250	0.0340	0.4160	150	0.034	0.100
Dimensions Listed for Authorized Contents				0.4930 (min.)	0.4250 (max.)		0.4160 (max.)	150 (max.)	0.034 (min.)	0.100 (max.)

HOLTEC INTERNATIONAL COPYRIGHTED MATERIAL

Table 6.2.28
 MAXIMUM K_{EFF} VALUES FOR THE 8X8F ASSEMBLY CLASS IN THE MPC-68
 (all dimensions are in inches)

8x8F (4.0% Enrichment, fixed neutron absorber ^{10}B minimum loading of 0.0279 g/cm ²) 64 fuel rods, 4 rectangular water cross segments dividing the assembly into four quadrants, pitch=0.609, Zr clad										
Fuel Assembly Designation	maximum k_{eff}	calculated k_{eff}	standard deviation	cladding OD	cladding ID	cladding thickness	pellet OD	fuel length	water rod thickness	channel thickness
8x8F01	0.9411	0.9366	0.0009	0.4576	0.3996	0.0290	0.3913	150	0.0315	0.055
Dimensions Listed for Authorized Contents				0.4576 (min.)	0.3996 (max.)		0.3913 (max.)	150 (max.)	0.0315 (min.)	0.055 (max.)

HOLTEC INTERNATIONAL COPYRIGHTED MATERIAL

Table 6.2.29
 MAXIMUM K_{EFF} VALUES FOR THE 9X9A ASSEMBLY CLASS IN THE MPC-68
 (all dimensions are in inches)

9x9A (4.2% Enrichment, fixed neutron absorber ^{10}B minimum loading of 0.0279 g/cm^2) 74/66 fuel rods [†] , 2 water rods, pitch=0.566, Zr clad										
Fuel Assembly Designation	maximum k_{eff}	calculated k_{eff}	standard deviation	cladding OD	cladding ID	cladding thickness	pellet OD	fuel length	water rod thickness	channel thickness
9x9A01 (axial segment with all rods)	0.9353	0.9310	0.0008	0.4400	0.3840	0.0280	0.3760	150	0.030	0.100
9x9A02 (axial segment with only the full length rods)	0.9388	0.9345	0.0008	0.4400	0.3840	0.0280	0.3760	150	0.030	0.100
9x9A03 (actual three-dimensional representation of all rods)	0.9351	0.9310	0.0007	0.4400	0.3840	0.0280	0.3760	150/90	0.030	0.100
9x9A04 (axial segment with only the full length rods)	0.9396	0.9355	0.0007	0.4400	0.3840	0.0280	0.3760	150	0.030	0.120
Dimensions Listed for Authorized Contents				0.4400 (min.)	0.3840 (max.)		0.3760 (max.)	150 (max.)	0.000 (min.)	0.120 (max.)
bounding dimensions (axial segment with only the full length rods) (B9x9A01)	0.9417	0.9374	0.0008	0.4400	0.3840	0.0280	0.3760	150	0.000	0.120

[†] This assembly class contains 66 full length rods and 8 partial length rods. In order to eliminate a requirement on the length of the partial length rods, separate calculations were performed for the axial segments with and without the partial length rods.

Table 6.2.30
 MAXIMUM K_{EFF} VALUES FOR THE 9X9B ASSEMBLY CLASS IN THE MPC-68
 (all dimensions are in inches)

9x9B (4.2% Enrichment, fixed neutron absorber ^{10}B minimum loading of 0.0279 g/cm ²) 72 fuel rods, 1 water rod (square, replacing 9 fuel rods), pitch=0.569 to 0.572 [†] , Zr clad											
Fuel Assembly Designation	maximum k_{eff}	calculated k_{eff}	standard deviation	pitch	cladding OD	cladding ID	cladding thickness	pellet OD	fuel length	water rod thickness	channel thickness
9x9B01	0.9380	0.9336	0.0008	0.569	0.4330	0.3807	0.0262	0.3737	150	0.0285	0.100
9x9B02	0.9373	0.9329	0.0009	0.569	0.4330	0.3810	0.0260	0.3737	150	0.0285	0.100
9x9B03	0.9417	0.9374	0.0008	0.572	0.4330	0.3810	0.0260	0.3737	150	0.0285	0.100
Dimensions Listed for Authorized Contents				0.572	0.4330 (min.)	0.3810 (max.)		0.3740 (max.)	150 (max.)	0.000 (min.)	0.120 (max.)
bounding dimensions (B9x9B01)	0.9436	0.9394	0.0008	0.572	0.4330	0.3810	0.0260	0.3740 ^{††}	150	0.000	0.120

[†] This assembly class was analyzed and qualified for a small variation in the pitch.

^{††} This value was conservatively defined to be larger than any of the actual pellet diameters.

Table 6.2.31
 MAXIMUM K_{EFF} VALUES FOR THE 9X9C ASSEMBLY CLASS IN THE MPC-68
 (all dimensions are in inches)

9x9C (4.2% Enrichment, fixed neutron absorber ^{10}B minimum loading of 0.0279 g/cm^2) 80 fuel rods, 1 water rods, pitch=0.572, Zr clad										
Fuel Assembly Designation	maximum k_{eff}	calculated k_{eff}	standard deviation	cladding OD	cladding ID	cladding thickness	pellet OD	fuel length	water rod thickness	channel thickness
9x9C01	0.9395	0.9352	0.0008	0.4230	0.3640	0.0295	0.3565	150	0.020	0.100
Dimensions Listed for Authorized Contents				0.4230 (min.)	0.3640 (max.)		0.3565 (max.)	150 (max.)	0.020 (min.)	0.100 (max.)

HOLTEC INTERNATIONAL COPYRIGHTED MATERIAL

Table 6.2.32
 MAXIMUM K_{EFF} VALUES FOR THE 9X9D ASSEMBLY CLASS IN THE MPC-68
 (all dimensions are in inches)

9x9D (4.2% Enrichment, fixed neutron absorber ^{10}B minimum loading of 0.0279 g/cm ²) 79 fuel rods, 2 water rods, pitch=0.572, Zr clad										
Fuel Assembly Designation	maximum k_{eff}	calculated k_{eff}	standard deviation	cladding OD	cladding ID	cladding thickness	pellet OD	fuel length	water rod thickness	channel thickness
9x9D01	0.9394	0.9350	0.0009	0.4240	0.3640	0.0300	0.3565	150	0.0300	0.100
Dimensions Listed for Authorized Contents				0.4240 (min.)	0.3640 (max.)		0.3565 (max.)	150 (max.)	0.0300 (min.)	0.100 (max.)

HOLTEC INTERNATIONAL COPYRIGHTED MATERIAL

Table 6.2.33
 MAXIMUM K_{EFF} VALUES FOR THE 9X9E ASSEMBLY CLASS IN THE MPC-68

(all dimensions are in inches)

9x9E (4.0% Enrichment, fixed neutron absorber ^{10}B minimum loading of 0.0279 g/cm^2)										
76 fuel rods, 5 water rods, pitch=0.572, Zr clad										
Fuel Assembly Designation	maximum k_{eff}	calculated k_{eff}	standard deviation	cladding OD	cladding ID	cladding thickness	pellet OD	fuel length	water rod thickness	channel thickness
9x9E01	0.9334	0.9293	0.0007	0.4170	0.3640	0.0265	0.3530	150	0.0120	0.120
9x9E02	0.9401	0.9359	0.0008	0.4170 0.4430	0.3640 0.3860	0.0265 0.0285	0.3530 0.3745	150	0.0120	0.120
Dimensions Listed for Authorized Contents [†]				0.4170 (min.)	0.3640 (max.)		0.3530 (max.)	150 (max.)	0.0120 (min.)	0.120 (max.)
bounding dimensions (9x9E02)	0.9401	0.9359	0.0008	0.4170 0.4430	0.3640 0.3860	0.0265 0.0285	0.3530 0.3745	150	0.0120	0.120

[†] This fuel assembly, also known as SPC 9x9-5, contains fuel rods with different cladding and pellet diameters which do not bound each other. To be consistent in the way fuel assemblies are listed for the authorized contents, two assembly classes (9x9E and 9x9F) are required to specify this assembly. Each class contains the actual geometry (9x9E02 and 9x9F02), as well as a hypothetical geometry with either all small rods (9x9E01) or all large rods (9x9F01). The Authorized Contents lists the small rod dimensions for class 9x9E and the large rod dimensions for class 9x9F, and a note that both classes are used to qualify the assembly. The analyses demonstrate that all configurations, including the actual geometry, are acceptable.

Table 6.2.34
 MAXIMUM K_{EFF} VALUES FOR THE 9X9F ASSEMBLY CLASS IN THE MPC-68

(all dimensions are in inches)

9x9F (4.0% Enrichment, fixed neutron absorber ^{10}B minimum loading of 0.0279 g/cm ²)										
76 fuel rods, 5 water rods, pitch=0.572, Zr clad										
Fuel Assembly Designation	maximum k_{eff}	calculated k_{eff}	standard deviation	cladding OD	cladding ID	cladding thickness	pellet OD	fuel length	water rod thickness	channel thickness
9x9F01	0.9307	0.9265	0.0007	0.4430	0.3860	0.0285	0.3745	150	0.0120	0.120
9x9F02	0.9401	0.9359	0.0008	0.4170	0.3640	0.0265	0.3530	150	0.0120	0.120
				0.4430	0.3860	0.0285	0.3745			
Dimensions Listed for Authorized Contents [†]				0.4430 (min.)	0.3860 (max.)		0.3745 (max.)	150 (max.)	0.0120 (min.)	0.120 (max.)
bounding dimensions (9x9F02)	0.9401	0.9359	0.0008	0.4170	0.3640	0.0265	0.3530	150	0.0120	0.120
				0.4430	0.3860	0.0285	0.3745			

[†] This fuel assembly, also known as SPC 9x9-5, contains fuel rods with different cladding and pellet diameters which do not bound each other. To be consistent in the way fuel assemblies are listed for the authorized contents, two assembly classes (9x9E and 9x9F) are required to specify this assembly. Each class contains the actual geometry (9x9E02 and 9x9F02), as well as a hypothetical geometry with either all small rods (9x9E01) or all large rods (9x9F01). The Authorized Contents lists the small rod dimensions for class 9x9E and the large rod dimensions for class 9x9F, and a note that both classes are used to qualify the assembly. The analyses demonstrate that all configurations, including the actual geometry, are acceptable.

HOLTEC INTERNATIONAL COPYRIGHTED MATERIAL

Table 6.2.35
 MAXIMUM K_{EFF} VALUES FOR THE 9X9G ASSEMBLY CLASS IN THE MPC-68
 (all dimensions are in inches)

9x9G (4.2% Enrichment, fixed neutron absorber ^{10}B minimum loading of 0.0279 g/cm^2) 72 fuel rods, 1 water rod (square, replacing 9 fuel rods), pitch=0.572, Zr clad										
Fuel Assembly Designation	maximum k_{eff}	calculated k_{eff}	standard deviation	cladding OD	cladding ID	cladding thickness	pellet OD	fuel length	water rod thickness	channel thickness
9x9G01	0.9309	0.9265	0.0008	0.4240	0.3640	0.0300	0.3565	150	0.0320	0.120
Dimensions Listed for Authorized Contents				0.4240 (min.)	0.3640 (max.)		0.3565 (max.)	150 (max.)	0.0320 (min.)	0.120 (max.)

HOLTEC INTERNATIONAL COPYRIGHTED MATERIAL

Table 6.2.36
 MAXIMUM K_{EFF} VALUES FOR THE 10X10A ASSEMBLY CLASS IN THE MPC-68

(all dimensions are in inches)

10x10A (4.2% Enrichment, fixed neutron absorber ^{10}B minimum loading of 0.0279 g/cm ²)										
92/78 fuel rods [†] , 2 water rods, pitch=0.510, Zr clad										
Fuel Assembly Designation	maximum k_{eff}	calculated k_{eff}	standard deviation	cladding OD	cladding ID	cladding thickness	pellet OD	fuel length	water rod thickness	channel thickness
10x10A01 (axial segment with all rods)	0.9377	0.9335	0.0008	0.4040	0.3520	0.0260	0.3450	155	0.030	0.100
10x10A02 (axial segment with only the full length rods)	0.9426	0.9386	0.0007	0.4040	0.3520	0.0260	0.3450	155	0.030	0.100
10x10A03 (actual three-dimensional representation of all rods)	0.9396	0.9356	0.0007	0.4040	0.3520	0.0260	0.3450	155/90	0.030	0.100
Dimensions Listed for Authorized Contents				0.4040 (min.)	0.3520 (max.)		0.3455 (max.)	150 ^{††} (max.)	0.030 (min.)	0.120 (max.)
bounding dimensions (axial segment with only the full length rods) (B10x10A01)	0.9457 ^{†††}	0.9414	0.0008	0.4040	0.3520	0.0260	0.3455 [‡]	155	0.030	0.120

[†] This assembly class contains 78 full-length rods and 14 partial-length rods. In order to eliminate the requirement on the length of the partial length rods, separate calculations were performed for axial segments with and without the partial length rods.

^{††} Although the analysis qualifies this assembly for a maximum active fuel length of 155 inches, the specification for the authorized contents limits the active fuel length to 150 inches. This is due to the fact that the fixed neutron absorber panels are 156 inches in length.

^{†††} KENO5a verification calculation resulted in a maximum k_{eff} of 0.9453.

[‡] This value was conservatively defined to be larger than any of the actual pellet diameters.

HOLTEC INTERNATIONAL COPYRIGHTED MATERIAL

Table 6.2.37
 MAXIMUM K_{EFF} VALUES FOR THE 10X10B ASSEMBLY CLASS IN THE MPC-68
 (all dimensions are in inches)

10x10B (4.2% Enrichment, fixed neutron absorber ^{10}B minimum loading of 0.0279 g/cm ²) 91/83 fuel rods [†] , 1 water rods (square, replacing 9 fuel rods), pitch=0.510, Zr clad										
Fuel Assembly Designation	maximum k_{eff}	calculated k_{eff}	standard deviation	cladding OD	cladding ID	cladding thickness	pellet OD	fuel length	water rod thickness	channel thickness
10x10B01 (axial segment with all rods)	0.9384	0.9341	0.0008	0.3957	0.3480	0.0239	0.3413	155	0.0285	0.100
10x10B02 (axial segment with only the full length rods)	0.9416	0.9373	0.0008	0.3957	0.3480	0.0239	0.3413	155	0.0285	0.100
10x10B03 (actual three-dimensional representation of all rods)	0.9375	0.9334	0.0007	0.3957	0.3480	0.0239	0.3413	155/90	0.0285	0.100
Dimensions Listed for Authorized Contents				0.3957 (min.)	0.3480 (max.)		0.3420 (max.)	150 ^{††} (max.)	0.000 (min.)	0.120 (max.)
bounding dimensions (axial segment with only the full length rods) (B10x10B01)	0.9436	0.9395	0.0007	0.3957	0.3480	0.0239	0.3420 ^{†††}	155	0.000	0.120

[†] This assembly class contains 83 full length rods and 8 partial length rods. In order to eliminate a requirement on the length of the partial length rods, separate calculations were performed for the axial segments with and without the partial length rods.

^{††} Although the analysis qualifies this assembly for a maximum active fuel length of 155 inches, the specification for the authorized contents limits the active fuel length to 150 inches. This is due to the fact that the fixed neutron absorber panels are 156 inches in length.

^{†††} This value was conservatively defined to be larger than any of the actual pellet diameters.

HOLTEC INTERNATIONAL COPYRIGHTED MATERIAL

Table 6.2.38
 MAXIMUM K_{EFF} VALUES FOR THE 10X10C ASSEMBLY CLASS IN THE MPC-68

(all dimensions are in inches)

10x10C (4.2% Enrichment, fixed neutron absorber ^{10}B minimum loading of 0.0279 g/cm ²) 96 fuel rods, 5 water rods (1 center diamond and 4 rectangular), pitch=0.488, Zr clad										
Fuel Assembly Designation	maximum k_{eff}	calculated k_{eff}	standard deviation	cladding OD	cladding ID	cladding thickness	pellet OD	fuel length	water rod thickness	channel thickness
10x10C01	0.9433	0.9392	0.0007	0.3780	0.3294	0.0243	0.3224	150	0.031	0.055
Dimensions Listed for Authorized Contents				0.3780 (min.)	0.3294 (max.)		0.3224 (max.)	150 (max.)	0.031 (min.)	0.055 (max.)

HOLTEC INTERNATIONAL COPYRIGHTED MATERIAL

Table 6.2.39
 MAXIMUM K_{EFF} VALUES FOR THE 10X10D ASSEMBLY CLASS IN THE MPC-68

(all dimensions are in inches)

10x10D (4.0% Enrichment, fixed neutron absorber ^{10}B minimum loading of 0.0279 g/cm ²)										
100 fuel rods, 0 water rods, pitch=0.565, SS clad										
Fuel Assembly Designation	maximum k_{eff}	calculated k_{eff}	standard deviation	cladding OD	cladding ID	cladding thickness	pellet OD	fuel length	water rod thickness	channel thickness
10x10D01	0.9376	0.9333	0.0008	0.3960	0.3560	0.0200	0.350	83	n/a	0.080
Dimensions Listed for Authorized Contents				0.3960 (min.)	0.3560 (max.)		0.350 (max.)	83 (max.)	n/a	0.080 (max.)

HOLTEC INTERNATIONAL COPYRIGHTED MATERIAL

Table 6.2.40
 MAXIMUM K_{EFF} VALUES FOR THE 10X10E ASSEMBLY CLASS IN THE MPC-68

(all dimensions are in inches)

10x10E (4.0% Enrichment, fixed neutron absorber ^{10}B minimum loading of 0.0279 g/cm ²) 96 fuel rods, 4 water rods, pitch=0.557, SS clad										
Fuel Assembly Designation	maximum k_{eff}	calculated k_{eff}	standard deviation	cladding OD	cladding ID	cladding thickness	pellet OD	fuel length	water rod thickness	channel thickness
10x10E01	0.9185	0.9144	0.0007	0.3940	0.3500	0.0220	0.3430	83	0.022	0.080
Dimensions Listed for Authorized Contents				0.3940 (min.)	0.3500 (max.)		0.3430 (max.)	83 (max.)	0.022 (min.)	0.080 (max.)

HOLTEC INTERNATIONAL COPYRIGHTED MATERIAL

Table 6.2.41
 MAXIMUM K_{EFF} VALUES FOR THE 6X6A ASSEMBLY CLASS IN THE MPC-68F and MPC-68
 (all dimensions are in inches)

6x6A (3.0% Enrichment [†] , fixed neutron absorber ¹⁰ B minimum loading of 0.0067 g/cm ²) 35 or 36 fuel rods ^{††} , 1 or 0 water rods ^{††} , pitch ^{††} =0.694 to 0.710, Zr clad												
Fuel Assembly Designation	maximum k_{eff}	calculated k_{eff}	standard deviation	pitch	fuel rods	cladding OD	cladding ID	cladding thickness	pellet OD	fuel length	water rod thickness	channel thickness
6x6A01	0.7539	0.7498	0.0007	0.694	36	0.5645	0.4945	0.0350	0.4940	110	n/a	0.060
6x6A02	0.7517	0.7476	0.0007	0.694	36	0.5645	0.4925	0.0360	0.4820	110	n/a	0.060
6x6A03	0.7545	0.7501	0.0008	0.694	36	0.5645	0.4945	0.0350	0.4820	110	n/a	0.060
6x6A04	0.7537	0.7494	0.0008	0.694	36	0.5550	0.4850	0.0350	0.4820	110	n/a	0.060
6x6A05	0.7555	0.7512	0.0008	0.696	36	0.5625	0.4925	0.0350	0.4820	110	n/a	0.060
6x6A06	0.7618	0.7576	0.0008	0.696	35	0.5625	0.4925	0.0350	0.4820	110	0.0	0.060
6x6A07	0.7588	0.7550	0.0005	0.700	36	0.5555	0.4850	0.03525	0.4780	110	n/a	0.060
6x6A08	0.7808	0.7766	0.0007	0.710	36	0.5625	0.5105	0.0260	0.4980	110	n/a	0.060
Dimensions Listed for Authorized Contents				0.710 (max.)	35 or 36	0.5550 (min.)	0.5105 (max.)	0.02225	0.4980 (max.)	120 (max.)	0.0	0.060 (max.)
bounding dimensions (B6x6A01)	0.7727	0.7685	0.0007	0.694	35	0.5550	0.5105	0.02225	0.4980	120	0.0	0.060
bounding dimensions (B6x6A02)	0.7782	0.7738	0.0008	0.700	35	0.5550	0.5105	0.02225	0.4980	120	0.0	0.060
bounding dimensions (B6x6A03)	0.7888	0.7846	0.0007	0.710	35	0.5550	0.5105	0.02225	0.4980	120	0.0	0.060

[†] Although the calculations were performed for 3.0%, the enrichment is limited in the specification for the authorized contents to 2.7%.
^{††} This assembly class was analyzed and qualified for a small variation in the pitch and a variation in the number of fuel and water rods.

HOLTEC INTERNATIONAL COPYRIGHTED MATERIAL

Table 6.2.42
 MAXIMUM K_{EFF} VALUES FOR THE 6X6B ASSEMBLY CLASS IN THE MPC-68F and MPC-68
 (all dimensions are in inches)

6x6B (3.0% Enrichment [†] , fixed neutron absorber ¹⁰ B minimum loading of 0.0067 g/cm ²) 35 or 36 fuel rods ^{††} (up to 9 MOX rods), 1 or 0 water rods ^{††} , pitch ^{††} =0.694 to 0.710, Zr clad												
Fuel Assembly Designation	maximum k_{eff}	calculated k_{eff}	standard deviation	pitch	fuel rods	cladding OD	cladding ID	cladding thickness	pellet OD	fuel length	water rod thickness	channel thickness
6x6B01	0.7604	0.7563	0.0007	0.694	36	0.5645	0.4945	0.0350	0.4820	110	n/a	0.060
6x6B02	0.7618	0.7577	0.0007	0.694	36	0.5625	0.4925	0.0350	0.4820	110	n/a	0.060
6x6B03	0.7619	0.7578	0.0007	0.696	36	0.5625	0.4925	0.0350	0.4820	110	n/a	0.060
6x6B04	0.7686	0.7644	0.0008	0.696	35	0.5625	0.4925	0.0350	0.4820	110	0.0	0.060
6x6B05	0.7824	0.7785	0.0006	0.710	35	0.5625	0.4925	0.0350	0.4820	110	0.0	0.060
Dimensions Listed for Authorized Contents				0.710 (max.)	35 or 36	0.5625 (min.)	0.4945 (max.)		0.4820 (max.)	120 (max.)	0.0	0.060 (max.)
bounding dimensions (B6x6B01)	0.7822 ^{†††}	0.7783	0.0006	0.710	35	0.5625	0.4945	0.0340	0.4820	120	0.0	0.060

Note:

1. These assemblies contain up to 9 MOX pins. The composition of the MOX fuel pins is given in Table 6.3.4.

[†] The ²³⁵U enrichment of the MOX and UO₂ pins is assumed to be 0.711% and 3.0%, respectively.

^{††} This assembly class was analyzed and qualified for a small variation in the pitch and a variation in the number of fuel and water rods.

^{†††} The k_{eff} value listed for the 6x6B05 case is slightly higher than that for the case with the bounding dimensions. However, the difference (0.0002) is well within the statistical uncertainties, and thus, the two values are statistically equivalent (within 1 σ). Therefore, the 0.7824 value is listed in Tables 6.1.7 and 6.1.8 as the maximum.

HOLTEC INTERNATIONAL COPYRIGHTED MATERIAL

HI-STORM FSAR

Rev. 11

REPORT HI-2002444

6.2-61

Table 6.2.43
 MAXIMUM K_{EFF} VALUES FOR THE 6X6C ASSEMBLY CLASS IN THE MPC-68F and MPC-68

(all dimensions are in inches)

6x6C (3.0% Enrichment [†] , fixed neutron absorber ¹⁰ B minimum loading of 0.0067 g/cm ²)										
36 fuel rods, 0 water rods, pitch=0.740, Zr clad										
Fuel Assembly Designation	maximum k_{eff}	calculated k_{eff}	standard deviation	cladding OD	cladding ID	cladding thickness	pellet OD	fuel length	water rod thickness	channel thickness
6x6C01	0.8021	0.7980	0.0007	0.5630	0.4990	0.0320	0.4880	77.5	n/a	0.060
Dimensions Listed for Authorized Contents				0.5630 (min.)	0.4990 (max.)		0.4880 (max.)	77.5 (max.)	n/a	0.060 (max.)

[†] Although the calculations were performed for 3.0%, the enrichment is limited in the specification for the authorized contents to 2.7%.

Table 6.2.44
 MAXIMUM K_{EFF} VALUES FOR THE 7X7A ASSEMBLY CLASS IN THE MPC-68F and MPC-68

(all dimensions are in inches)

7x7A (3.0% Enrichment [†] , fixed neutron absorber ¹⁰ B minimum loading of 0.0067 g/cm ²) 49 fuel rods, 0 water rods, pitch=0.631, Zr clad										
Fuel Assembly Designation	maximum k_{eff}	calculated k_{eff}	standard deviation	cladding OD	cladding ID	cladding thickness	pellet OD	fuel length	water rod thickness	channel thickness
7x7A01	0.7974	0.7932	0.0008	0.4860	0.4204	0.0328	0.4110	80	n/a	0.060
Dimensions Listed for Authorized Contents				0.4860 (min.)	0.4204 (max.)		0.4110 (max.)	80 (max.)	n/a	0.060 (max.)

[†] Although the calculations were performed for 3.0%, the enrichment is limited in the specification for the authorized contents to 2.7%.

Table 6.2.45
 MAXIMUM K_{EFF} VALUES FOR THE 8X8A ASSEMBLY CLASS IN THE MPC-68F and MPC-68

(all dimensions are in inches)

8x8A (3.0% Enrichment [†] , fixed neutron absorber ¹⁰ B minimum loading of 0.0067 g/cm ²)											
63 or 64 fuel rods ^{††} , 0 water rods, pitch=0.523, Zr clad											
Fuel Assembly Designation	maximum k_{eff}	calculated k_{eff}	standard deviation	fuel rods	cladding OD	cladding ID	cladding thickness	pellet OD	fuel length	water rod thickness	channel thickness
8x8A01	0.7685	0.7644	0.0007	64	0.4120	0.3620	0.0250	0.3580	110	n/a	0.100
8x8A02	0.7697	0.7656	0.0007	63	0.4120	0.3620	0.0250	0.3580	120	n/a	0.100
Dimensions Listed for Authorized Contents				63	0.4120 (min.)	0.3620 (max.)		0.3580 (max.)	120 (max.)	n/a	0.100 (max.)
bounding dimensions (8x8A02)	0.7697	0.7656	0.0007	63	0.4120	0.3620	0.0250	0.3580	120	n/a	0.100

[†] Although the calculations were performed for 3.0%, the enrichment is limited in the specification for the authorized contents to 2.7%.

^{††} This assembly class was analyzed and qualified for a variation in the number of fuel rods.

HOLTEC INTERNATIONAL COPYRIGHTED MATERIAL

Table 6.2.46

SPECIFICATION OF THE THORIA ROD CANISTER AND THE THORIA RODS

Canister ID	4.81"
Canister Wall Thickness	0.11"
Separator Assembly Plates Thickness	0.11"
Cladding OD	0.412"
Cladding ID	0.362"
Pellet OD	0.358"
Active Length	110.5"
Fuel Composition	1.8% UO ₂ and 98.2% ThO ₂
Initial Enrichment	93.5 wt% ²³⁵ U for 1.8% of the fuel
Maximum k _{eff}	0.1813
Calculated k _{eff}	0.1779
Standard Deviation	0.0004

HOLTEC INTERNATIONAL COPYRIGHTED MATERIAL

HI-STORM FSAR

Rev. 11

REPORT HI-2002444

6.2-65

6.3 MODEL SPECIFICATION

6.3.1 Description of Calculational Model

Figures 6.3.1, 6.3.1.a, 6.3.2 and 6.3.3 show representative horizontal cross sections of the four types of cells used in the calculations, and Figures 6.3.4 through 6.3.6 illustrate the basket configurations used. Four different MPC fuel basket designs were evaluated as follows:

- a 24 PWR assembly basket
- an optimized 24 PWR assembly basket (24E)
- a 32 PWR assembly basket
- a 68 BWR assembly basket.

For all four basket designs, the same techniques and the same level of detail are used in the calculational models.

Full three-dimensional calculations were used, assuming the axial configuration shown in Figure 6.3.7. Although the fixed neutron absorber panels are 156 inches in length, which is much longer than the active fuel length (maximum of 150 inches), they are assumed equal to or less than the active fuel length in the calculations. As shown on the Drawings in Section 1.5, 16 of the 24 periphery fixed neutron absorber panels on the MPC-24 and MPC-24E have reduced width (i.e., 6.25 inches wide as opposed to 7.5 inches). However, the calculational models for these baskets conservatively assume all of the periphery fixed neutron absorber panels are 6.25 inches in width. Note that Figures 6.3.1 through 6.3.3 show Boral as the fixed neutron absorber. The effect of using Metamic as fixed neutron absorber is discussed in Subsection 6.4.11.

The off-normal and accident conditions defined in Chapter 2 and considered in Chapter 11 have no adverse effect on the design conditions important to criticality safety (see Subsection 6.4.2.5), and thus from a criticality standpoint, the normal, off-normal, and accident conditions are identical and do not require individual models.

The calculational model explicitly defines the fuel rods and cladding, the guide tubes (or water rods for BWR assemblies), the water-gaps and fixed neutron absorber panels on the stainless steel walls of the storage cells. Under the conditions of storage, when the MPC is dry, the resultant reactivity with the design basis fuel is very low ($k_{\text{eff}} < 0.52$). For the flooded condition (loading and unloading), pure, unborated water was assumed to be present in the fuel rod pellet-to-clad gaps. Appendix 6.D provides sample input files for two of the MPC basket designs (MPC-68 and MPC-24) in the HI-STORM 100 System.

HOLTEC INTERNATIONAL COPYRIGHTED MATERIAL

The water thickness above and below the fuel is intentionally maintained less than or equal to the actual water thickness. This assures that any positive reactivity effect of the steel in the MPC is conservatively included. Furthermore, the water above and below the fuel is modeled as unborated water, even when borated water is present in the fuel region.

As indicated in Figures 6.3.1 through 6.3.3 and in Tables 6.3.1 and 6.3.2, calculations were made with dimensions assumed to be at their most conservative value with respect to criticality. CASMO-3 and MCNP4a were used to determine the direction of the manufacturing tolerances, which produced the most adverse effect on criticality. After the directional effect (positive effect with an increase in reactivity; or negative effect with a decrease in reactivity) of the manufacturing tolerances was determined, the criticality analyses were performed using the worst case tolerances in the direction which would increase reactivity.

CASMO-3 was used for one of each of the two principal basket designs, i.e. for the flux trap design MPC-24 and for the non-fluxtrap design MPC-68. The effects are shown in Table 6.3.1 which also identifies the approximate magnitude of the tolerances on reactivity. Generally, the conclusions in Table 6.3.1 are directly applicable to the MPC-24E and the MPC-32. Exceptions are the conclusions for the water temperature and void percentage, which are not directly applicable to the MPC-32 due to the presence of high soluble boron concentrations in this canister. This condition is addressed in Section 6.4.2.1 where the optimum moderation is determined for the MPC-32.

Additionally, MCNP4a calculations are performed to evaluate the tolerances of the various basket dimensions of the MPC-68, MPC-24 and MPC-32 in further detail. The various basket dimensions are inter-dependent, and therefore cannot be individually varied (i.e., reduction in one parameter requires a corresponding reduction or increase in another parameter). Thus, it is not possible to determine the reactivity effect of each individual dimensional tolerance separately. However, it is possible to determine the reactivity effect of the dimensional tolerances by evaluating the various possible dimensional combinations. To this end, an evaluation of the various possible dimensional combinations was performed using MCNP4a. Calculated k_{eff} results (which do not include the bias, uncertainties, or calculational statistics), along with the actual dimensions, for a number of dimensional combinations are shown in Table 6.3.2 for the reference PWR and BWR assemblies. Each of the basket dimensions are evaluated for their minimum, nominal and maximum values from the Drawings of section 1.5. For PWR MPC designs, the reactivity effect of tolerances with soluble boron present in the water is additionally determined. Due to the close similarity between the MPC-24 and MPC-24E, the basket dimensions are only evaluated for the MPC-24, and the same dimensional assumptions are applied to both MPC designs.

Based on the MCNP4a and CASMO-3 calculations, the conservative dimensional assumptions

HOLTEC INTERNATIONAL COPYRIGHTED MATERIAL

listed in Table 6.3.3 were determined. Because the reactivity effect (positive or negative) of the manufacturing tolerances are not assembly dependent, these dimensional assumptions were employed for the criticality analyses.

As demonstrated in this section, design parameters important to criticality safety are: fuel enrichment, the inherent geometry of the fuel basket structure, the fixed neutron absorbing panels and the soluble boron concentration in the water during loading/unloading operations. As shown in Chapter 11, none of these parameters are affected during any of the design basis off-normal or accident conditions involving handling, packaging, transfer or storage.

The MPC-32 criticality model uses a sheathing thickness of 0.075 inches, whereas the actual MPC-32 design uses a sheathing thickness of 0.035 inches. For the minimum cell pitch of 9.158 inches, the thicker sheathing results in a slightly smaller cell ID of 8.69 inches (minimum), compared to 8.73 inches (minimum) for the thinner sheathing. To demonstrate that the dimensions used in the criticality model are acceptable and conservative, calculations were performed for both sheathing thicknesses and the results are compared in Table 6.3.5. To bound various soluble boron levels, two comparisons were performed. The first comparison uses the bounding case for the MPC-32 (see Table 6.1.6), which is for assembly class 15x15F at 5 wt% ^{235}U and a soluble boron level of 2600 ppm. To bound lower soluble boron levels, the second comparison uses the same assembly class (15x15F), 0 ppm soluble boron (i.e. pure water), and an arbitrary enrichment of 1.7 wt% ^{235}U . In both comparisons, the results of the 0.075 inch sheathing are slightly higher, i.e. more conservative, than the results for 0.035 inch sheathing, although the differences are within the statistical uncertainties. Using a sheathing thickness of 0.075 inches in the criticality models of the MPC-32 is therefore acceptable, and potentially more conservative, than using the actual value of 0.035 inches. This validates the choice of the dimensional assumptions for the MPC-32 shown in Table 6.3.3, which are used for all further MPC-32 criticality calculations, unless otherwise noted.

6.3.2 Cask Regional Densities

Composition of the various components of the principal designs of the HI-STORM 100 System are listed in Table 6.3.4.

The HI-STORM 100 System is designed such that the fixed neutron absorber will remain effective for a storage period greater than 20 years, and there are no credible means to lose it. A detailed physical description, historical applications, unique characteristics, service experience, and manufacturing quality assurance of fixed neutron absorber are provided in Section 1.2.1.3.1.

The continued efficacy of the fixed neutron absorber is assured by acceptance testing, documented in Section 9.1.5.3, to validate the ^{10}B (poison) concentration in the fixed neutron absorber. To demonstrate that the neutron flux from the irradiated fuel results in a negligible

HOLTEC INTERNATIONAL COPYRIGHTED MATERIAL

depletion of the poison material over the storage period, an MCNP4a calculation of the number of neutrons absorbed in the ^{10}B was performed. The calculation conservatively assumed a constant neutron source for 50 years equal to the initial source for the design basis fuel, as determined in Section 5.2, and shows that the fraction of ^{10}B atoms destroyed is only $2.6\text{E}-09$ in 50 years. Thus, the reduction in ^{10}B concentration in the fixed neutron absorber by neutron absorption is negligible. In addition, the results presented in Subsection 3.4.4.3.1.8 demonstrate that the sheathing, which affixes the fixed neutron absorber panel, remains in place during all credible accident conditions, and thus, the fixed neutron absorber panel remains permanently fixed. Therefore, in accordance with 10CFR72.124(b), there is no need to provide a surveillance or monitoring program to verify the continued efficacy of the neutron absorber.

6.3.3 Eccentric Positioning of Assemblies in Fuel Storage Cells

Up to and including Revision 1 of this FSAR, all criticality calculations were performed with fuel assemblies centered in the fuel storage locations since the effect of credible eccentric fuel positioning was judged to be not significant. Starting in Revision 2 of this FSAR, the potential reactivity effect of eccentric positioning of assemblies in the fuel storage locations is accounted for in a conservatively bounding fashion, as described further in this subsection, for all new or changed conditions. The calculations in this subsection serve to determine for which of these conditions the eccentric positioning of assemblies in the fuel storage locations results in a higher maximum k_{eff} value than the centered positioning. For the cases where the eccentric positioning results in a higher maximum k_{eff} value, the eccentric positioning is used for all corresponding cases reported in the summary tables in Section 6.1 and the results tables in Section 6.4. All other calculations throughout this chapter, such as studies to determine bounding fuel dimensions, bounding basket dimensions, or bounding moderation conditions, are performed with assemblies centered in the fuel storage locations.

To conservatively account for eccentric fuel positioning in the fuel storage cells, three different configurations are analyzed, and the results are compared to determine the bounding configuration:

- Cell Center Configuration: All assemblies centered in their fuel storage cell; same configuration that is used in Section 6.2 and Section 6.3.1;
- Basket Center Configuration: All assemblies in the basket are moved as close to the center of the basket as permitted by the basket geometry; and
- Basket Periphery Configuration: All assemblies in the basket are moved furthest away from the basket center, and as close to the periphery of the basket as possible.

It should be noted that the two eccentric configurations are hypothetical, since there is no known physical effect that could move all assemblies within a basket consistently to the center or periphery. Instead, the most likely configuration would be that all assemblies are moved in the

HOLTEC INTERNATIONAL COPYRIGHTED MATERIAL

same direction when the cask is in a horizontal position, and that assemblies are positioned randomly when the cask is in a vertical position. Further, it is not credible to assume that any such configuration could exist by chance. Even if the probability for a single assembly placed in the corner towards the basket center would be 1/5 (i.e. assuming only the center and four corner positions in each cell, all with equal probability), then the probability that all assemblies would be located towards the center would be $(1/5)^{24}$ or approximately 10^{-17} for the MPC-24, $(1/5)^{32}$ or approximately 10^{-23} for the MPC-32, and $(1/5)^{68}$ or approximately 10^{-48} for the MPC-68. However, since the configurations listed above bound all credible configurations, they are conservatively used in the analyses.

In Table 6.3.6, results are presented for all conditions that were introduced in Revision 2 of this FSAR, namely results for the MPC-24E with intact and damaged fuel at 5 wt% ^{235}U , for the MPC-32 with soluble boron levels lower than 2600 ppm for 5 wt% ^{235}U and lower than 1900 ppm for 4.1 wt% ^{235}U , and for the MPC-32 with intact and damaged fuel. The table shows the maximum k_{eff} value for centered and the two eccentric configurations for each condition, and the difference in k_{eff} between the centered and eccentric positioning. The results and conclusions are summarized as follows:

- In all cases, moving the assemblies to the periphery of the basket results in a reduction in reactivity, compared to the cell centered position.
- For the MPC-24E, moving the assemblies and DFCs towards the center of the basket also results in a minor reduction. The cell centered configuration is therefore bounding for this condition and is used in the design basis calculations reported in Section 6.1 and Section 6.4.
- For the MPC-32 cases listed in Table 6.3.6, the maximum reactivity is shown for the basket center configuration. However, for some of the cases with intact and damaged fuel in the MPC-32, the cell centered configuration results in a higher maximum reactivity. Therefore, both the cell centered and basket centered configuration are analyzed for the MPC-32 design basis calculation, and the higher results are listed in the tables in Section 6.1. and 6.4. This applies to the cases with intact and damaged fuel, and to cases with intact fuel only and soluble boron levels lower than 2600 ppm for 5 wt% ^{235}U and lower than 1900 ppm for 4.1 wt% ^{235}U .

HOLTEC INTERNATIONAL COPYRIGHTED MATERIAL

HI-STORM FSAR
REPORT HI-2002444

6.3-5

Rev. 7

Table 6.3.1

CASMO-3 CALCULATIONS FOR EFFECT OF TOLERANCES AND TEMPERATURE

Change in Nominal Parameter [†]	Δk for Maximum Tolerance		Action/Modeling Assumption
	MPC-24 [‡]	MPC-68	
Reduce Fixed Neutron Absorber Width to Minimum	N/A ^{†††} min. = nom. = 7.5" and 6.25"	N/A ^{†††} min. = nom. = 4.75"	Assume minimum fixed neutron absorber width
Increase UO ₂ Density to Maximum	+0.0017 max. = 10.522 g/cc nom. = 10.412 g/cc	+0.0014 max. = 10.522 g/cc nom. = 10.412 g/cc	Assume maximum UO ₂ density
Reduce Box Inside Dimension (I.D.) to Minimum	-0.0005 min. = 8.86" nom. = 8.92"	See Table 6.3.2	Assume maximum box I.D. for the MPC-24
Increase Box Inside Dimension (I.D.) to Maximum	+0.0007 max. = 8.98" nom. = 8.92"	-0.0030 max. = 6.113" nom. = 6.053"	Assume minimum box I.D. for the MPC-68
Decrease Water Gap to Minimum	+0.0069 min. = 1.09" nom. = 1.15"	N/A	Assume minimum water gap in the MPC-24

[†] Reduction (or increase) in a parameter indicates that the parameter is changed to its minimum (or maximum) value.

[‡] Calculations for the MPC-24 were performed with CASMO-4 [6.3.1-6.3.3].

^{†††} The fixed neutron absorber width for the MPC-68 is 4.75" +0.125", -0", the fixed neutron absorber widths for the MPC-24 are 7.5" +0.125", -0" and 6.25" +0.125" -0" (i.e., the nominal and minimum values are the same).

HOLTEC INTERNATIONAL COPYRIGHTED MATERIAL

Table 6.3.1 (continued)

CASMO-3 CALCULATIONS FOR EFFECT OF TOLERANCES AND TEMPERATURE

Change in Nominal Parameter	Δk Maximum Tolerance		Action/Modeling Assumption
	MPC-24 [‡]	MPC-68	
Increase in Temperature			Assume 20°C
20°C	Ref.	Ref.	
40°C	-0.0030	-0.0039	
70°C	-0.0089	-0.0136	
100°C	-0.0162	-0.0193	
10% Void in Moderator			Assume no void
20°C with no void	Ref.	Ref.	
20°C	-0.0251	-0.0241	
100°C	-0.0412	-0.0432	
Removal of Flow Channel (BWR)	N/A	-0.0073	Assume flow channel present for MPC-68

[‡] Calculations for the MPC-24 were performed with CASMO-4 [6.3.1-6.3.3].

HOLTEC INTERNATIONAL COPYRIGHTED MATERIAL

Table 6.3.2

MCNP4a EVALUATION OF BASKET MANUFACTURING TOLERANCES[†]

Pitch		Box I.D.		Box Wall Thickness		MCNP4a Calculated k_{eff}
MPC-24 ^{††} (17x17A01 @ 4.0% Enrichment)						
nominal	(10.906")	maximum	(8.98")	nominal	(5/16")	0.9325±0.0008 ^{†††}
minimum	(10.846")	nominal	(8.92")	nominal	(5/16")	0.9300±0.0008
nominal	(10.906")	nom. - 0.04"	(8.88")	nom. + 0.05"	(0.3625")	0.9305±0.0007
MPC-68 (8x8C04 @ 4.2% Enrichment)						
minimum	(6.43")	minimum	(5.993")	nominal	(1/4")	0.9307±0.0007
nominal	(6.49")	nominal	(6.053")	nominal	(1/4")	0.9274±0.0007
maximum	(6.55")	maximum	(6.113")	nominal	(1/4")	0.9272±0.0008
nom. + 0.05"	(6.54")	nominal	(6.053")	nom. + 0.05"	(0.30")	0.9267±0.0007

Notes:

1. Values in parentheses are the actual value used.

[†] Tolerance for pitch and box I.D. are ± 0.06".
Tolerance for box wall thickness is +0.05", -0.00".

^{††} All calculations for the MPC-24 assume minimum water gap thickness (1.09").

^{†††} Numbers are 1 σ statistical uncertainties.

HOLTEC INTERNATIONAL COPYRIGHTED MATERIAL

HI-STORM FSAR
REPORT HI-2002444

6.3-8

Rev. 7

Table 6.3.2 (cont.)

MCNP4a EVALUATION OF BASKET MANUFACTURING TOLERANCES[†]

Pitch		Box I.D.		Box Wall Thickness		MCNP4a Calculated k_{eff}
MPC-24 (17x17A @ 5.0% Enrichment) 400ppm soluble boron						
nominal	(10.906")	maximum	(8.98")	nominal	(5/16")	0.9236±0.0007 ^{††}
maximum	(10.966")	maximum	(8.98")	nominal	(5/16")	0.9176±0.0008
minimum	(10.846")	nominal	(8.92")	nominal	(5/16")	0.9227±0.0010
minimum	(10.846")	minimum	(8.86")	nominal	(5/16")	0.9159±0.0008
nominal	(10.906")	nominal-0.04"	(8.88")	nom.+0.05"	(0.3625")	0.9232±0.0009
nominal	(10.906")	nominal	(8.92")	nominal	(5/16")	0.9158±0.0007
MPC-32 (17x17A @ 5.0% Enrichment) 2600 ppm soluble boron ^{†††}						
minimum	(9.158")	minimum	(8.69")	nominal	(9/32")	0.9085±0.0007
nominal	(9.218")	nominal	(8.75")	nominal	(9/32")	0.9028±0.0007
maximum	(9.278")	maximum	(8.81")	nominal	(9/32")	0.8996±0.0008
nominal+0.05"	(9.268")	nominal	(8.75")	nominal+0.05"	(0.331")	0.9023±0.0008
minimum+0.05"	(9.208")	minimum	(8.69")	nominal+0.05"	(0.331")	0.9065±0.0007
maximum	(9.278")	Maximum-0.05"	(8.76")	nominal+0.05"	(0.331")	0.9030±0.0008

Notes:

- Values in parentheses are the actual value used.

† Tolerance for pitch and box I.D. are ± 0.06".
Tolerance for box wall thickness is +0.05", -0.00".

†† Numbers are 1σ statistical uncertainties.

††† for 0.075" sheathing thickness. See Section 6.3.1 and Table 6.3.5 for reactivity effect of sheathing thickness.

HOLTEC INTERNATIONAL COPYRIGHTED MATERIAL

Table 6.3.3

BASKET DIMENSIONAL ASSUMPTIONS

Basket Type	Pitch	Box I.D.	Box Wall Thickness	Water-Gap Flux Trap
MPC-24	nominal (10.906")	maximum (8.98")	nominal (5/16")	minimum (1.09")
MPC-24E	nominal (10.847")	maximum (8.81", 9.11" for DFC Positions)	nominal (5/16")	minimum (1.076", 0.776" for DFC Positions)
MPC-32	Minimum (9.158")	Minimum [†] (8.69")	Nominal (9/32")	N/A
MPC-68	minimum (6.43")	Minimum (5.993")	nominal (1/4")	N/A

[†] for 0.075" sheathing thickness. See Section 6.3.1 and Table 6.3.5 for reactivity effect of sheathing thickness.

HOLTEC INTERNATIONAL COPYRIGHTED MATERIAL

Table 6.3.4

COMPOSITION OF THE MAJOR COMPONENTS OF THE HI-STORM 100 SYSTEM

MPC-24, MPC-24E and MPC-32		
UO₂ 5.0% ENRICHMENT, DENSITY (g/cc) = 10.522		
Nuclide	Atom-Density	Wgt. Fraction
8016	4.696E-02	1.185E-01
92235	1.188E-03	4.408E-02
92238	2.229E-02	8.374E-01
UO₂ 4.0% ENRICHMENT, DENSITY (g/cc) = 10.522		
Nuclide	Atom-Density	Wgt. Fraction
8016	4.693E-02	1.185E-01
92235	9.505E-04	3.526E-02
92238	2.252E-02	8.462E-01
BORAL (0.02 g ¹⁰B/cm sq), DENSITY (g/cc) = 2.660 (MPC-24)		
Nuclide	Atom-Density	Wgt. Fraction
5010	8.707E-03	5.443E-02
5011	3.512E-02	2.414E-01
6012	1.095E-02	8.210E-02
13027	3.694E-02	6.222E-01
BORAL (0.0279 g ¹⁰B/cm sq), DENSITY (g/cc) = 2.660 (MPC-24E and MPC-32)		
Nuclide	Atom-Density	Wgt. Fraction
5010	8.071E-03	5.089E-02
5011	3.255E-02	2.257E-01
6012	1.015E-02	7.675E-02
13027	3.805E-02	6.467E-01

HOLTEC INTERNATIONAL COPYRIGHTED MATERIAL

HI-STORM FSAR
REPORT HI-2002444

6.3-11

Rev. 7

Table 6.3.4 (continued)

COMPOSITION OF THE MAJOR COMPONENTS OF THE HI-STORM 100 SYSTEM

METAMIC (0.02 g ¹⁰B/cm sq), DENSITY (g/cc) = 2.648 (MPC-24)		
Nuclide	Atom-Density	Wgt. Fraction
5010	6.314E-03	3.965E-02
5011	2.542E-02	1.755E-01
6012	7.932E-02	5.975E-02
13027	4.286E-02	7.251E-01
METAMIC (0.0279 g ¹⁰B/cm sq), DENSITY (g/cc) = 2.646 (MPC-24E and MPC-32)		
Nuclide	Atom-Density	Wgt. Fraction
5010	6.541E-03	4.110E-02
5011	2.633E-02	1.819E-01
6012	8.217E-03	6.193E-02
13027	4.223E-02	7.151E-01

HOLTEC INTERNATIONAL COPYRIGHTED MATERIAL

HI-STORM FSAR
REPORT HI-2002444

6.3-12

Rev. 7

Table 6.3.4 (continued)

COMPOSITION OF THE MAJOR COMPONENTS OF THE HI-STORM 100 SYSTEM

BORATED WATER, 300 PPM, DENSITY (g/cc)=1.00		
Nuclide	Atom-Density	Wt. Fraction
5010	3.248E-06	5.400E-05
5011	1.346E-05	2.460E-04
1001	6.684E-02	1.1186E-01
8016	3.342E-02	8.8784E-01
BORATED WATER, 400PPM, DENSITY (g/cc)=1.00		
Nuclide	Atom-Density	Wgt. Fraction
5010	4.330E-06	7.200E-05
5011	1.794E-05	3.280E-04
1001	6.683E-02	1.1185E-01
8016	3.341E-02	8.8775E-01
BORATED WATER, 1900PPM, DENSITY (g/cc)=1.00		
Nuclide	Atom-Density	Wgt. Fraction
5010	2.057E-05	3.420E-04
5011	8.522E-05	1.558E-03
1001	6.673E-02	1.1169E-01
8016	3.336E-02	8.8641E-01
BORATED WATER, 2600PPM, DENSITY (g/cc)=0.93		
Nuclide	Atom-Density	Wgt. Fraction
5010	2.618e-05	4.680E-04
5011	1.085e-04	2.132E-03
1001	6.201e-02	1.1161E-01
8016	3.101e-02	8.8579E-01

HOLTEC INTERNATIONAL COPYRIGHTED MATERIAL

Table 6.3.4 (continued)

COMPOSITION OF THE MAJOR COMPONENTS OF THE HI-STORM 100 SYSTEM

MPC-68		
UO₂ 4.2% ENRICHMENT, DENSITY (g/cc) = 10.522		
Nuclide	Atom-Density	Wgt. Fraction
8016	4.697E-02	1.185E-01
92235	9.983E-04	3.702E-02
92238	2.248E-02	8.445E-01
UO₂ 3.0% ENRICHMENT, DENSITY (g/cc) = 10.522		
Nuclide	Atom-Density	Wgt. Fraction
8016	4.695E-02	1.185E-01
92235	7.127E-04	2.644E-02
92238	2.276E-02	8.550E-01
MOX FUEL[†], DENSITY (g/cc) = 10.522		
Nuclide	Atom-Density	Wgt. Fraction
8016	4.714E-02	1.190E-01
92235	1.719E-04	6.380E-03
92238	2.285E-02	8.584E-01
94239	3.876E-04	1.461E-02
94240	9.177E-06	3.400E-04
94241	3.247E-05	1.240E-03
94242	2.118E-06	7.000E-05

[†] The Pu-238, which is an absorber, was conservatively neglected in the MOX description for analysis purposes.

HOLTEC INTERNATIONAL COPYRIGHTED MATERIAL

Table 6.3.4 (continued)

COMPOSITION OF THE MAJOR COMPONENTS OF THE HI-STORM 100 SYSTEM

BORAL (0.0279 g ¹⁰B/cm sq), DENSITY (g/cc) = 2.660		
Nuclide	Atom-Density	Wgt. Fraction
5010	8.071E-03	5.089E-02
5011	3.255E-02	2.257E-01
6012	1.015E-02	7.675E-02
13027	3.805E-02	6.467E-01
METAMIC (0.0279 g ¹⁰B/cm sq), DENSITY (g/cc) = 2.646		
Nuclide	Atom-Density	Wgt. Fraction
5010	6.541E-03	4.110E-02
5011	2.633E-02	1.819E-01
6012	8.217E-03	6.193E-02
13027	4.223E-02	7.151E-01
FUEL IN THORIA RODS, DENSITY (g/cc) = 10.522		
Nuclide	Atom-Density	Wgt. Fraction
8016	4.798E-02	1.212E-01
92235	4.001E-04	1.484E-02
92238	2.742E-05	1.030E-03
90232	2.357E-02	8.630E-01
COMMON MATERIALS		
ZR CLAD, DENSITY (g/cc) = 6.550		
Nuclide	Atom-Density	Wgt. Fraction
40000	4.323E-02	1.000E+00
MODERATOR (H₂O), DENSITY (g/cc) = 1.000		
Nuclide	Atom-Density	Wgt. Fraction
1001	6.688E-02	1.119E-01
8016	3.344E-02	8.881E-01

HOLTEC INTERNATIONAL COPYRIGHTED MATERIAL

HI-STORM FSAR
REPORT HI-2002444

6.3-15

Rev. 7

Table 6.3.4 (continued)

COMPOSITION OF THE MAJOR COMPONENTS OF THE HI-STORM 100 SYSTEM

STAINLESS STEEL, DENSITY (g/cc) = 7.840		
Nuclide	Atom-Density	Wgt. Fraction
24000	1.761E-02	1.894E-01
25055	1.761E-03	2.001E-02
26000	5.977E-02	6.905E-01
28000	8.239E-03	1.000E-01
ALUMINUM, DENSITY (g/cc) = 2.700		
Nuclide	Atom-Density	Wgt. Fraction
13027	6.026E-02	1.000E+00

HOLTEC INTERNATIONAL COPYRIGHTED MATERIAL

HI-STORM FSAR
 REPORT HI-2002444

6.3-16

Rev. 7

Table 6.3.4 (continued)

COMPOSITION OF THE MAJOR COMPONENTS OF THE HI-STORM 100 SYSTEM

CONCRETE, DENSITY (g/cc) = 2.35		
Nuclide	Atom-Density	Wgt. Fraction
1001	8.806E-03	6.000E-03
8016	4.623E-02	5.000E-01
11000	1.094E-03	1.700E-02
13027	2.629E-04	4.800E-03
14000	1.659E-02	3.150E-01
19000	7.184E-04	1.900E-02
20000	3.063E-03	8.300E-02
26000	3.176E-04	1.200E-02
LEAD, DENSITY (g/cc) = 11.34		
Nuclide	Atom-Density	Wgt. Fraction
82000	3.296E-02	1.0
HOLTITE-A, DENSITY (g/cc) = 1.61		
1001	5.695E-02	5.920E-02
5010	1.365E-04	1.410E-03
5011	5.654E-04	6.420E-03
6012	2.233E-02	2.766E-01
7014	1.370E-03	1.980E-02
8016	2.568E-02	4.237E-01
13027	7.648E-03	2.129E-01

HOLTEC INTERNATIONAL COPYRIGHTED MATERIAL

HI-STORM FSAR
REPORT HI-2002444

6.3-17

Rev. 7

Table 6.3.5

REACTIVITY EFFECT OF SHEATHING THICKNESS FOR THE MPC-32

Assembly Class	Enrichment (wt% ²³⁵ U)	Soluble Boron (ppm)	Maximum k _{eff}		Difference in Maximum k _{eff}
			Sheathing 0.075" Min. Cell ID 8.69"	Sheathing 0.035" Min. Cell ID 8.73"	
15x15F	5.0	2600	0.9483	0.9476	-0.0008
15x15F	1.7	0	0.8914	0.8909	-0.0005

HOLTEC INTERNATIONAL COPYRIGHTED MATERIAL

HI-STORM FSAR
REPORT HI-2002444

6.3-18

Rev. 7

Table 6.3.6

REACTIVITY EFFECTS OF ECCENTRIC POSITIONING OF CONTENT
(FUEL ASSEMBLIES AND DFCs) IN BASKET CELLS

CASE	Contents centered (Reference)	Content moved towards center of basket		Content moved towards basket periphery	
	Maximum k_{eff}	Maximum k_{eff}	k_{eff} Difference to Reference	Maximum k_{eff}	k_{eff} Difference to Reference
MPC-24E, Intact Fuel and Damaged Fuel/Fuel Debris, 5% Enrichment, 600ppm Soluble Boron	0.9185	0.9178	-0.0007	0.9132	-0.0053
MPC-32, Intact Fuel, Assembly Class 16x16A, 4.1% Enrichment, 1400ppm Soluble Boron	0.9332	0.9367	0.0035	0.8992	-0.0340
MPC-32, Intact Fuel, Assembly Class 15x15B, 5.0% Enrichment, 2400ppm Soluble Boron	0.9473	0.9493	0.0020	0.9306	-0.0167
MPC-32, Intact Fuel and Damaged Fuel/Fuel Debris, Assembly Class 15x15F (Intact), 5% Enrichment, 2900ppm Soluble Boron	0.9378	0.9397	0.0019	0.9277	-0.0101

HOLTEC INTERNATIONAL COPYRIGHTED MATERIAL

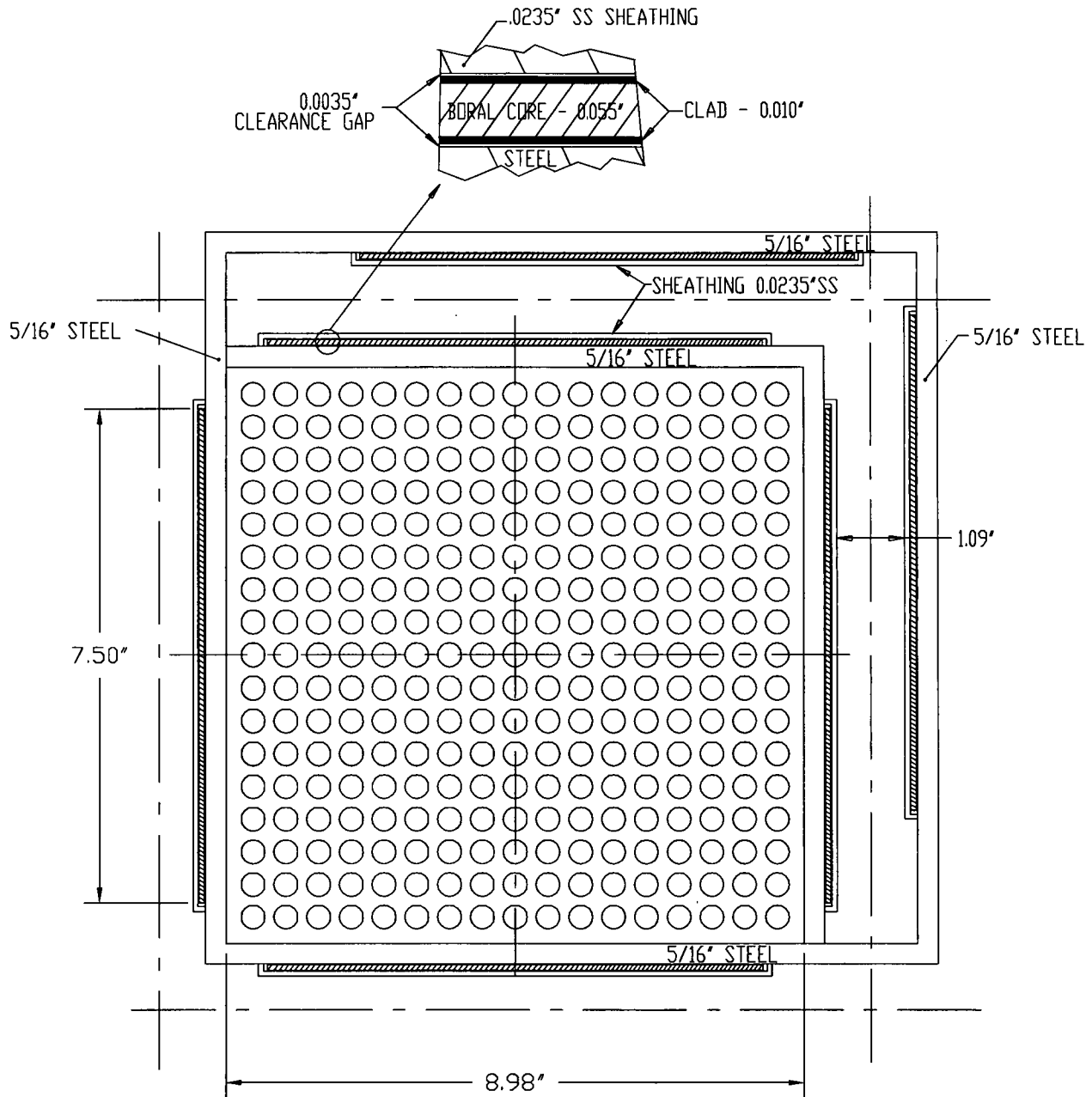


FIGURE 6.3.1; TYPICAL CELL IN THE CALCULATION MODEL (PLANAR CROSS-SECTION) WITH REPRESENTATIVE FUEL IN THE MPC-24 BASKET

(SEE CHAPTER 1 FOR TRUE BASKET DIMENSIONS)

NOTE: THESE DIMENSIONS WERE CONSERVATIVELY USED FOR CRITICALITY ANALYSES.

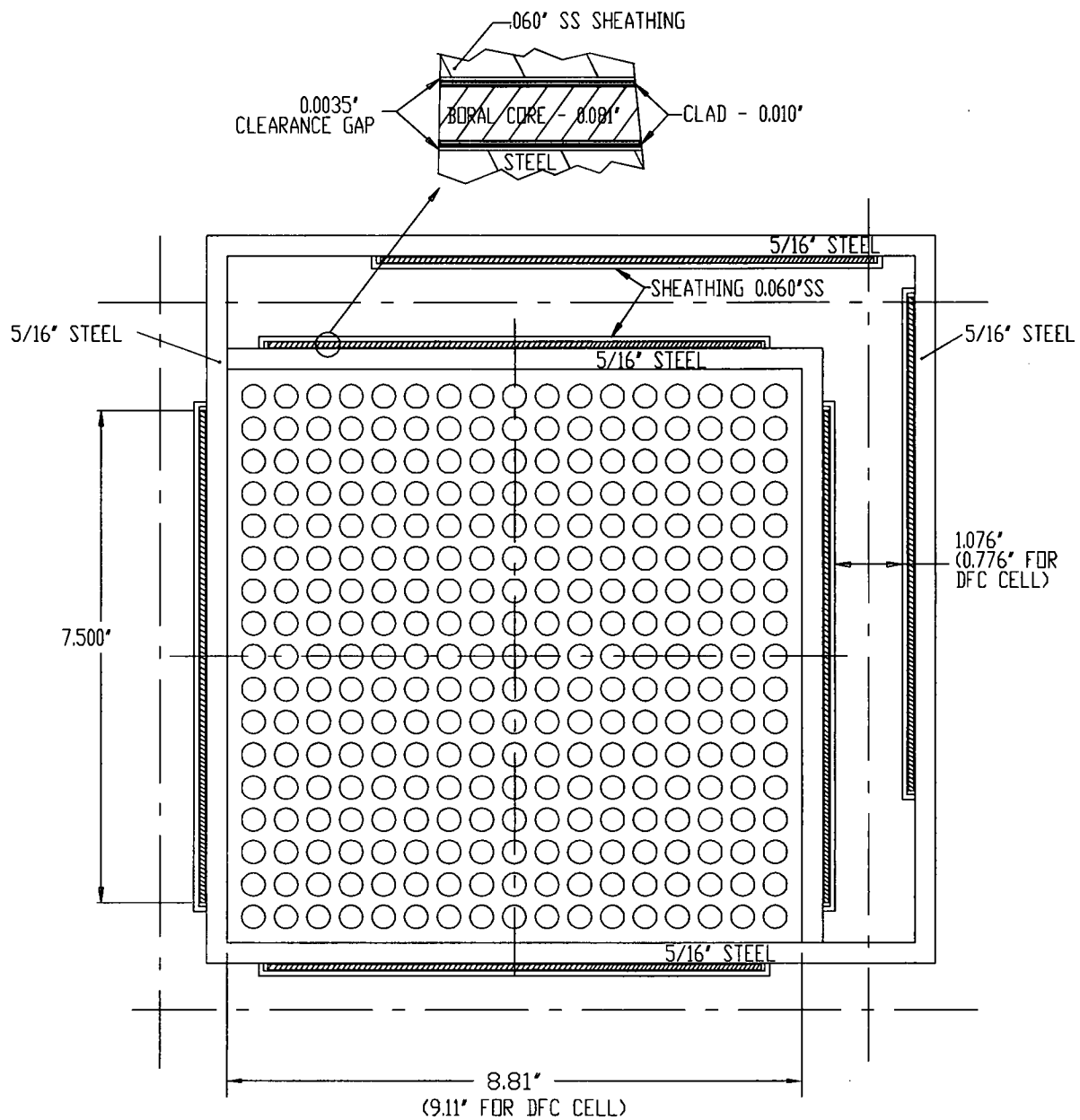


FIGURE 6.3.1A; TYPICAL CELL IN THE CALCULATION MODEL (PLANAR CROSS-SECTION) WITH REPRESENTATIVE FUEL IN THE MPC-24E BASKET
 (SEE CHAPTER 1 FOR TRUE BASKET DIMENSIONS)

NOTE: THESE DIMENSIONS WERE CONSERVATIVELY USED FOR CRITICALITY ANALYSES.

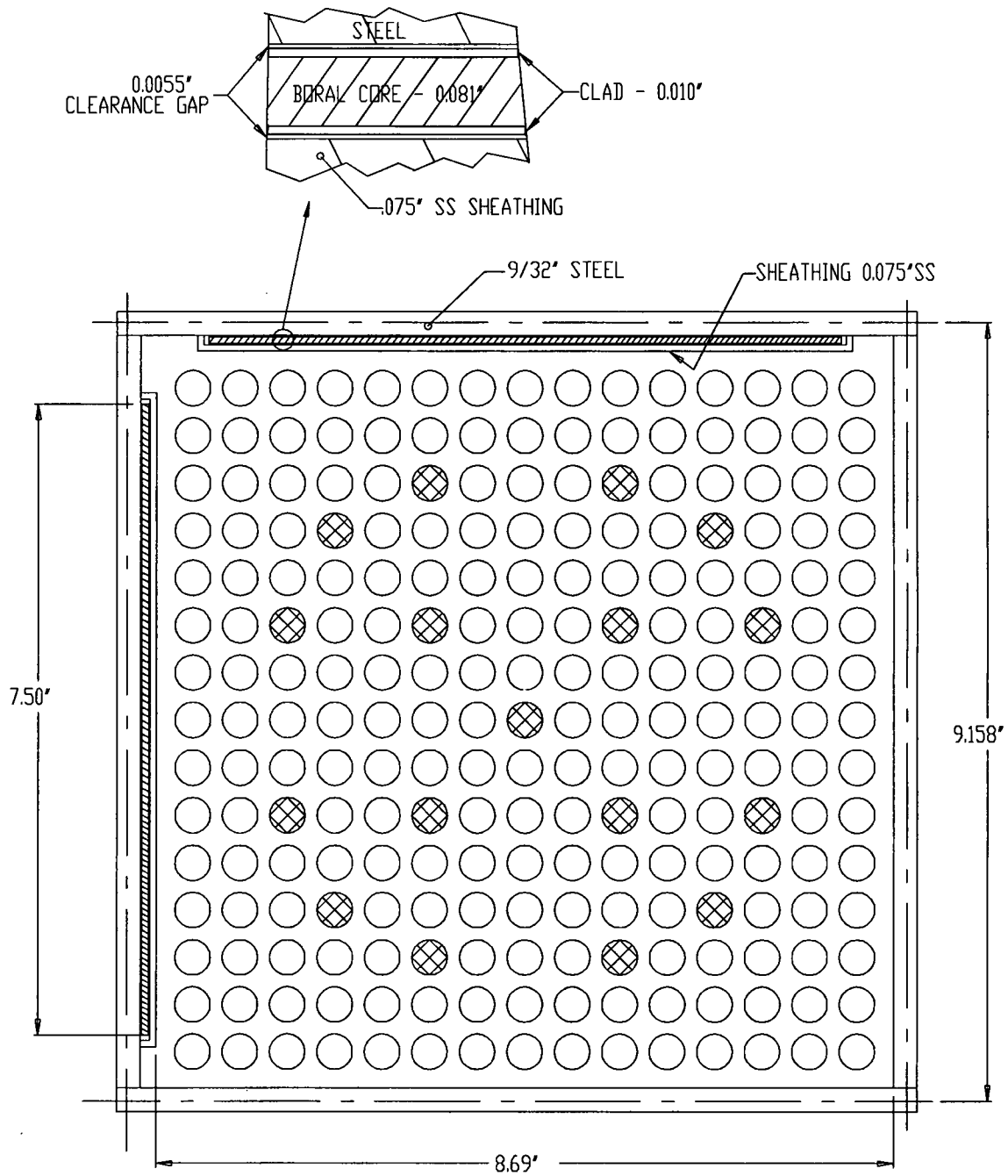


FIGURE 6.3.2; TYPICAL CELL IN THE CALCULATION MODEL (PLANAR CROSS-SECTION) WITH REPRESENTATIVE FUEL IN THE MPC-32 BASKET (SEE CHAPTER 1 FOR TRUE BASKET DIMENSIONS)

NOTE: THESE DIMENSIONS WERE CONSERVATIVELY USED FOR CRITICALITY ANALYSES.

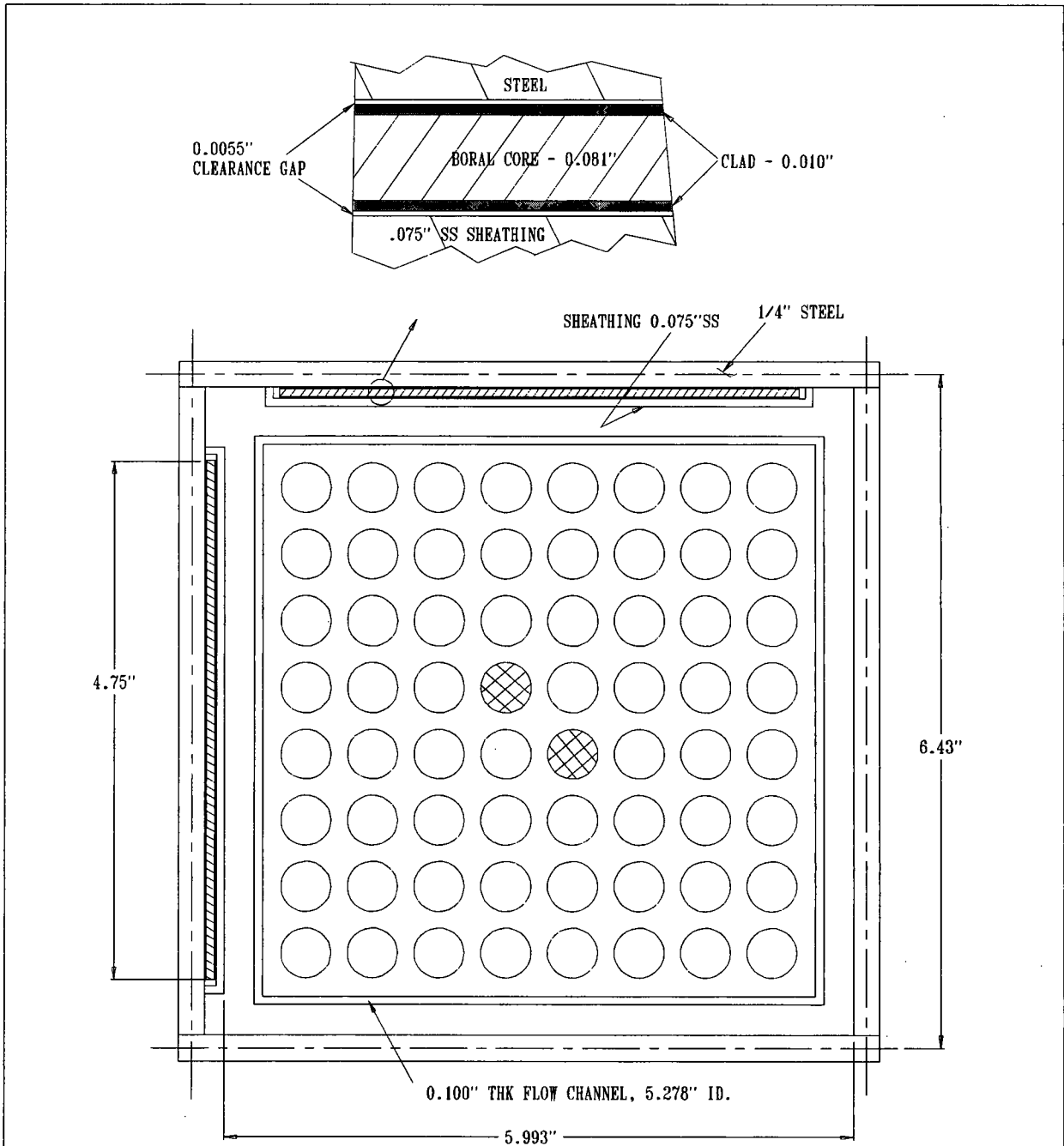


FIGURE 6.3.3; TYPICAL CELL IN THE CALCULATION MODEL (PLANAR CROSS-SECTION) WITH REPRESENTATIVE FUEL IN THE MPC-68 BASKET (SEE CHAPTER 1 FOR TRUE BASKET DIMENSIONS)

NOTE: THESE DIMENSIONS WERE CONSERVATIVELY USED FOR CRITICALITY ANALYSES.

REPORT HI-2002444

REVISION 0

F:\PROJECTS\5014\HI2002444\6_3_3

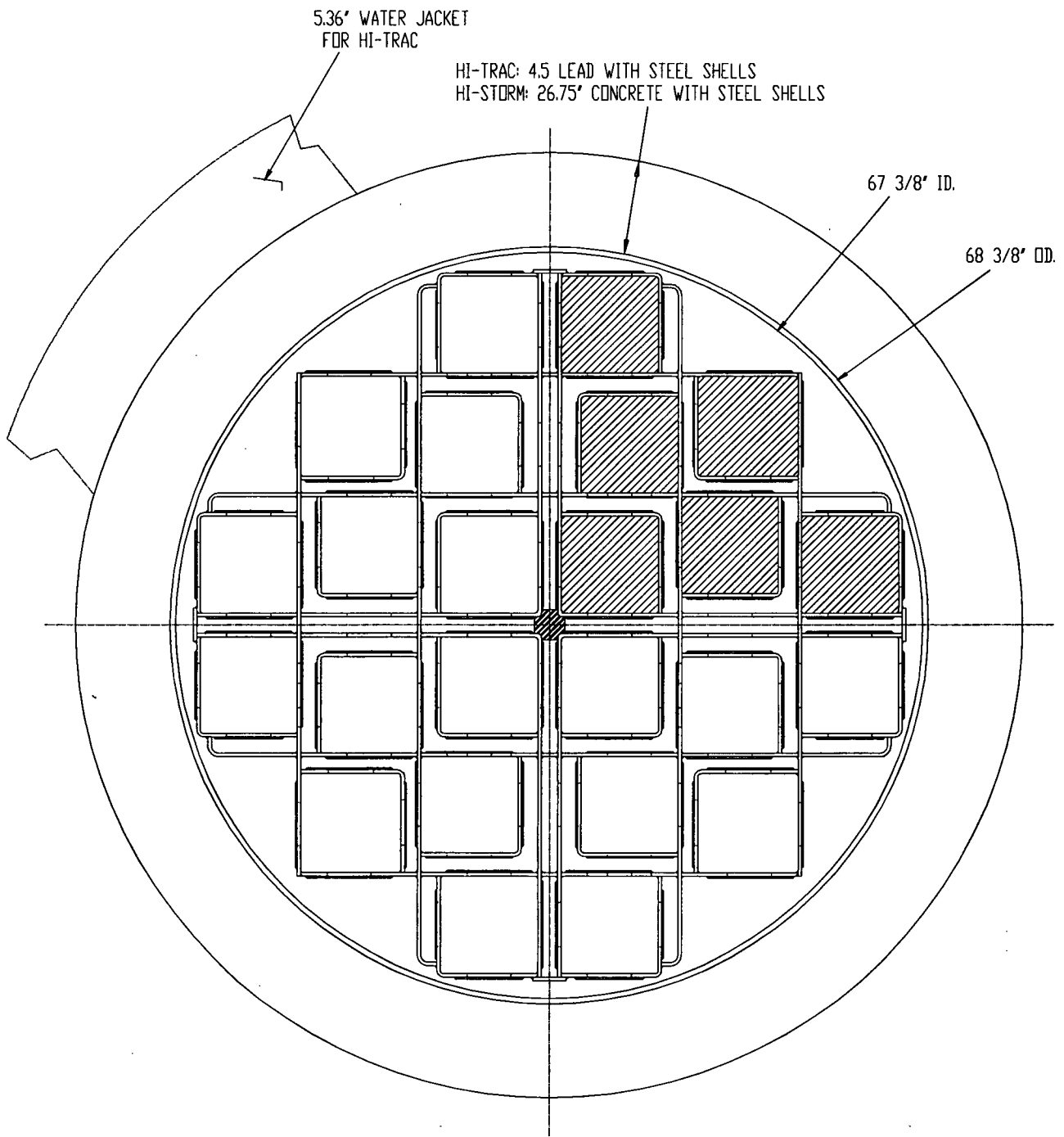


FIGURE 6.3.4; CALCULATION MODEL (PLANAR CROSS-SECTION)
WITH FUEL ILLUSTRATED IN ONE QUADRANT OF
THE MPC -24 AND THE MPC-24E.

(SEE CHAPTER 1 FOR TRUE BASKET DIMENSIONS)

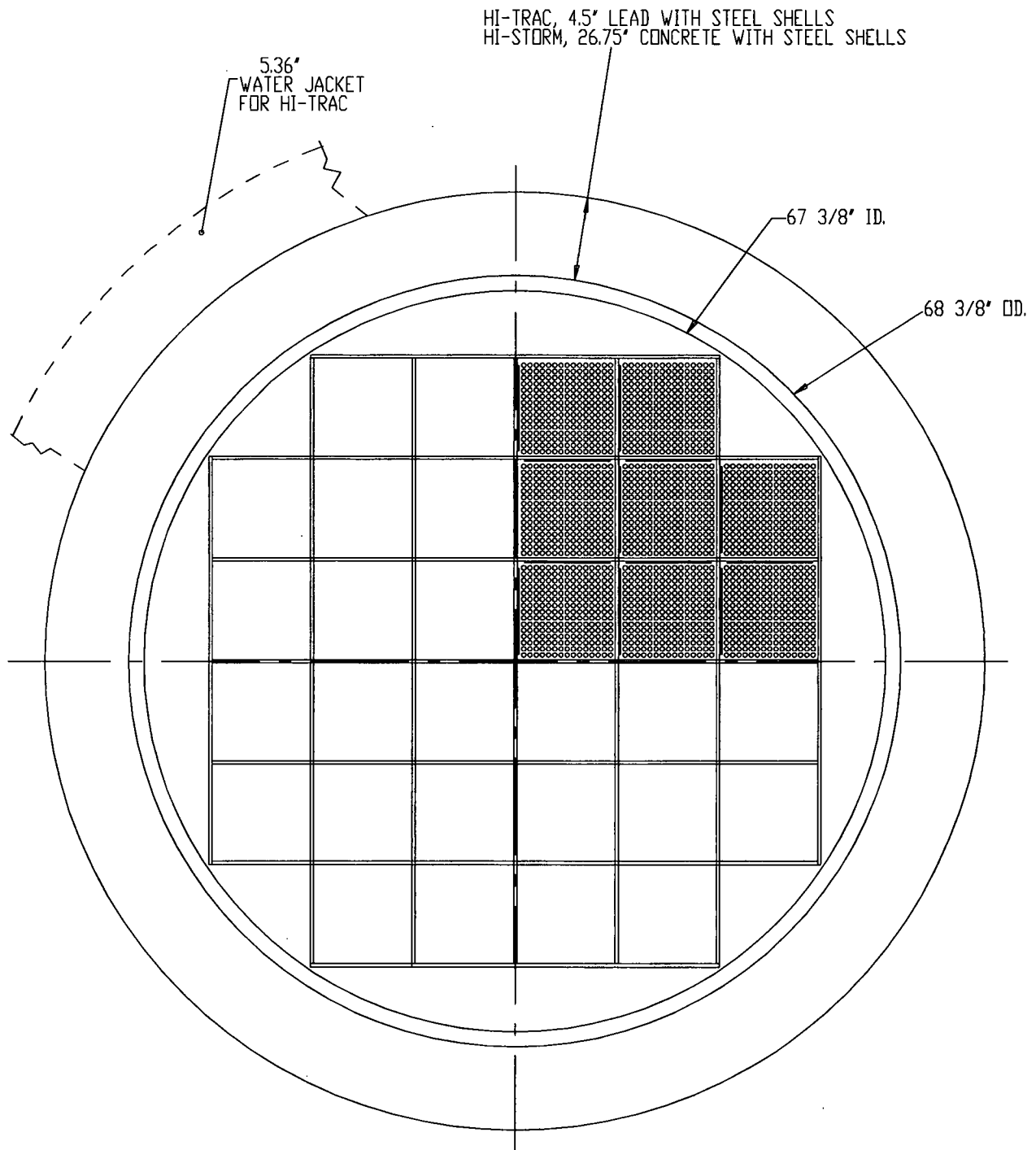


FIGURE 6.3.5; CALCULATION MODEL (PLANAR CROSS-SECTION)
WITH FUEL ILLUSTRATED IN ONE QUADRANT OF
THE MPC-32.

(SEE CHAPTER 1 FOR TRUE BASKET DIMENSIONS)

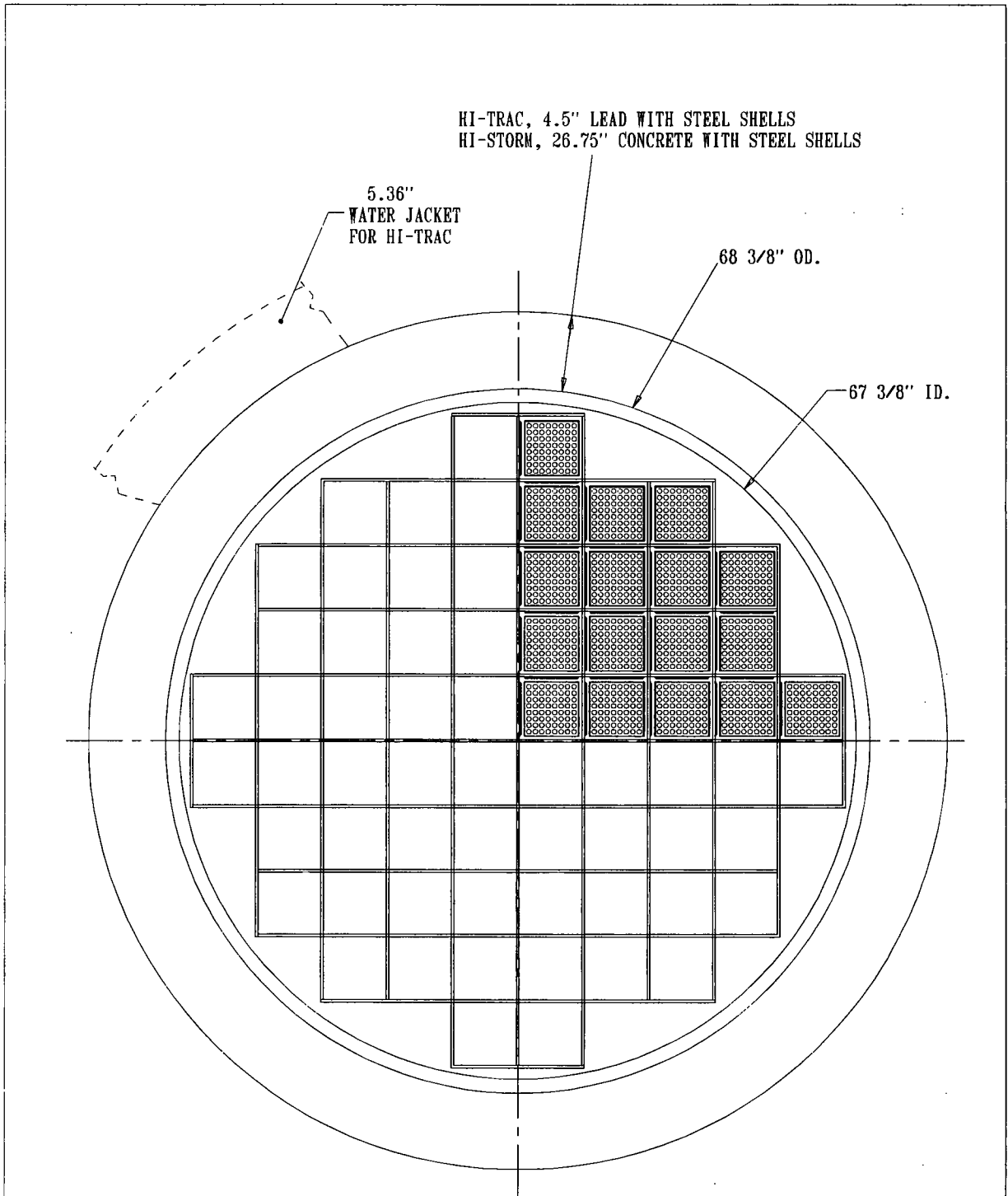


FIGURE 6.3.6; CALCULATION MODEL (PLANAR CROSS-SECTION)
 WITH FUEL ILLUSTRATED IN ONE QUADRANT OF
 THE MPC-68
 (SEE CHAPTER 1 FOR TRUE BASKET DIMENSIONS)

REPORT HI-2002444

REVISION 0

F:\PROJECTS\5014\HI2002444\6_3_6

	ACTIVE FUEL LENGTH	LOWER WATER THICKNESS	UPPER WATER THICKNESS
MPC-68	SEE TABLE 6.2.1	7.30 IN.	8.46 IN.
MPC-24,-24E & -32	SEE TABLE 6.2.2	4.0 IN.	6.0 IN.

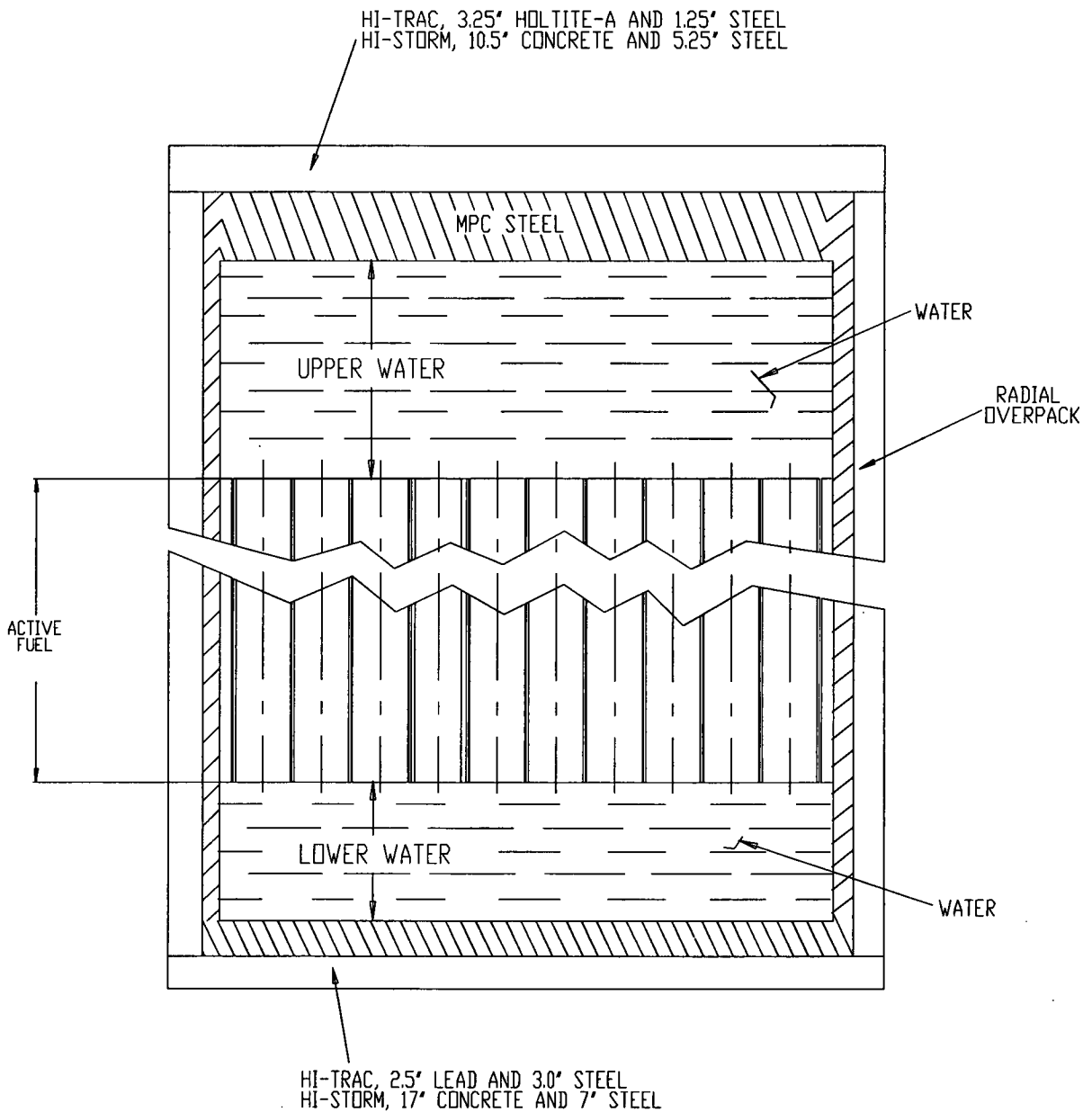


FIGURE 6.3.7; SKETCH OF THE CALCULATIONAL MODEL IN THE AXIAL DIRECTION

6.4 CRITICALITY CALCULATIONS

6.4.1 Calculational or Experimental Method

6.4.1.1 Basic Criticality Safety Calculations

The principal method for the criticality analysis is the general three-dimensional continuous energy Monte Carlo N-Particle code MCNP4a [6.1.4] developed at the Los Alamos National Laboratory. MCNP4a was selected because it has been extensively used and verified and has all of the necessary features for this analysis. MCNP4a calculations used continuous energy cross-section data based on ENDF/B-V, as distributed with the code [6.1.4]. Independent verification calculations were performed with NITAWL-KENO5a [6.1.5], which is a three-dimensional multigroup Monte Carlo code developed at the Oak Ridge National Laboratory. The KENO5a calculations used the 238-group cross-section library, which is based on ENDF/B-V data and is distributed as part of the SCALE-4.3 package [6.4.1], in association with the NITAWL-II program [6.1.6], which adjusts the uranium-238 cross sections to compensate for resonance self-shielding effects. The Dancoff factors required by NITAWL-II were calculated with the CELLDAN code [6.1.13], which includes the SUPERDAN code [6.1.7] as a subroutine.

The convergence of a Monte Carlo criticality problem is sensitive to the following parameters: (1) number of histories per cycle, (2) the number of cycles skipped before averaging, (3) the total number of cycles and (4) the initial source distribution. The MCNP4a criticality output contains a great deal of useful information that may be used to determine the acceptability of the problem convergence. This information was used in parametric studies to develop appropriate values for the aforementioned criticality parameters to be used in the criticality calculations for this submittal. Based on these studies, a minimum of 5,000 histories were simulated per cycle, a minimum of 20 cycles were skipped before averaging, a minimum of 100 cycles were accumulated, and the initial source was specified as uniform over the fueled regions (assemblies). Further, the output was examined to ensure that each calculation achieved acceptable convergence. These parameters represent an acceptable compromise between calculational precision and computational time. Appendix 6.D provides sample input files for the MPC-24 and MPC-68 basket in the HI-STORM 100 System.

CASMO-3 [6.1.9] was used for determining the small incremental reactivity effects of manufacturing tolerances. Although CASMO-3 has been extensively benchmarked, these calculations are used only to establish direction of reactivity uncertainties due to manufacturing tolerances (and their magnitude). This allows the MCNP4a calculational model to use the worst combination of manufacturing tolerances. Table 6.3.1 shows results of the CASMO-3 calculations.

HOLTEC INTERNATIONAL COPYRIGHTED MATERIAL

HI-STORM FSAR
REPORT HI-2002444

6.4-1

Rev. 11

6.4.2 Fuel Loading or Other Contents Loading Optimization

The basket designs are intended to safely accommodate fuel with enrichments indicated in Tables 6.1.1 through 6.1.8 . These calculations were based on the assumption that the HI-STORM 100 System (HI-TRAC transfer cask) was fully flooded with clean unborated water or water containing specific minimum soluble boron concentrations. In all cases, the calculations include bias and calculational uncertainties, as well as the reactivity effects of manufacturing tolerances, determined by assuming the worst case geometry.

6.4.2.1 Internal and External Moderation

As required by NUREG-1536, calculations in this section demonstrate that the HI-STORM 100 System remains subcritical for all credible conditions of moderation.

6.4.2.1.1 Unborated Water

With a neutron absorber present (i.e., the fixed neutron absorber sheets or the steel walls of the storage compartments), the phenomenon of a peak in reactivity at a hypothetical low moderator density (sometimes called "optimum" moderation) does not occur to any significant extent. In a definitive study, Cano, et al. [6.4.2] has demonstrated that the phenomenon of a peak in reactivity at low moderator densities does not occur in the presence of strong neutron absorbing material or in the absence of large water spaces between fuel assemblies in storage. Nevertheless, calculations for a single reflected cask were made to confirm that the phenomenon does not occur with low density water inside or outside the casks.

Calculations for the MPC designs with internal and external moderators of various densities are shown in Table 6.4.1. For comparison purposes, a calculation for a single unreflected cask (Case 1) is also included in Table 6.4.1. At 100% external moderator density, Case 2 corresponds to a single fully-flooded cask, fully reflected by water. Figure 6.4.10 plots calculated k_{eff} values ($\pm 2\sigma$) as a function of internal moderator density for both MPC designs with 100% external moderator density (i.e., full water reflection). Results listed in Table 6.4.1 support the following conclusions:

- For each type of MPC, the calculated k_{eff} for a fully-flooded cask is independent of the external moderator (the small variations in the listed values are due to statistical uncertainties which are inherent to the calculational method (Monte Carlo)), and
- For each type of MPC, reducing the internal moderation results in a monotonic reduction in reactivity, with no evidence of any optimum moderation. Thus, the fully flooded condition corresponds to the highest reactivity, and the phenomenon of optimum low-density moderation does not occur and is not applicable to the HI-STORM 100 System.

For each of the MPC designs, the maximum k_{eff} values are shown to be less than or statistically

HOLTEC INTERNATIONAL COPYRIGHTED MATERIAL

equal to that of a single internally flooded unreflected cask and are below the regulatory limit of 0.95.

6.4.2.1.2 Borated Water

With the presence of a soluble neutron absorber in the water, the discussion in the previous section is not always applicable. Calculations were made to determine the optimum moderator density for the MPC designs that require a minimum soluble boron concentration.

Calculations for the MPC designs with various internal moderator densities are shown in Table 6.4.6. As shown in the previous section, the external moderator density has a negligible effect on the reactivity, and is therefore not varied. Water containing soluble boron has a slightly higher density than pure water. Therefore, water densities up to 1.005 g/cm^3 were analyzed for the higher soluble boron concentrations. Additionally, for the higher soluble boron concentrations, analyses have been performed with empty (voided) guide tubes. This variation is discussed in detail in Section 6.4.8. Results listed in the Table 6.4.6 support the following conclusions:

- For all cases with a soluble boron concentration of up to 1900ppm, and for a soluble boron concentration of 2600ppm assuming voided guide tubes, the conclusion of the Section 6.4.2.1.1 applies, i.e. the maximum reactivity is corresponds to 100% moderator density.
- For 2600ppm soluble boron concentration with filled guide tubes, the results presented in Table 6.4.6 indicate that there is a maximum of the reactivity somewhere between 0.90 g/cm^3 and 1.00 g/cm^3 moderator density. However, a distinct maximum can not be identified, as the reactivities in this range are very close. For the purpose of the calculations with 2600ppm soluble boron concentration, a moderator density of 0.93 g/cm^3 was chosen, which corresponds to the highest calculated reactivity listed in Table 6.4.6.

The calculations documented in this chapter also use soluble boron concentrations other than 1900 ppm and 2600 ppm in the MPC-32. For the MPC-32 loaded with intact fuel only, soluble boron concentrations between 1300 ppm and 2600 ppm are used. For the MPC-32 loaded with intact fuel, damaged fuel and fuel debris, soluble boron concentrations between 1500 ppm and 2900 ppm are used. In order to determine the optimum moderation condition for each assembly class at the corresponding soluble boron level, evaluations are performed with filled and voided guide tubes, and for water densities of 1.0 g/cm^3 and 0.93 g/cm^3 for each class and enrichment level. Results for the MPC-32 loaded with intact fuel only are listed in Table 6.4.10 for an initial enrichment of 5.0 wt% ^{235}U and in Table 6.4.11 for an initial enrichment of 4.1 wt% ^{235}U . Corresponding results for the MPC-32 loaded with intact fuel, damaged fuel and fuel debris are listed in Table 6.4.14. The highest value listed in these tables for each assembly class is listed as the bounding value in Section 6.1.

HOLTEC INTERNATIONAL COPYRIGHTED MATERIAL

6.4.2.2 Partial Flooding

As required by NUREG-1536, calculations in this section address partial flooding in the HI-STORM 100 System and demonstrate that the fully flooded condition is the most reactive.

The reactivity changes during the flooding process were evaluated in both the vertical and horizontal positions for all MPC designs. For these calculations, the cask is partially filled (at various levels) with full density (1.0 g/cc) water and the remainder of the cask is filled with steam consisting of ordinary water at partial density (0.002 g/cc), as suggested in NUREG-1536. Results of these calculations are shown in Table 6.4.2. In all cases, the reactivity increases monotonically as the water level rises, confirming that the most reactive condition is fully flooded.

6.4.2.3 Clad Gap Flooding

As required by NUREG-1536, the reactivity effect of flooding the fuel rod pellet-to-clad gap regions, in the fully flooded condition, has been investigated. Table 6.4.3 presents maximum k_{eff} values that demonstrate the positive reactivity effect associated with flooding the pellet-to-clad gap regions. These results confirm that it is conservative to assume that the pellet-to-clad gap regions are flooded. For all cases that involve flooding, the pellet-to-clad gap regions are assumed to be flooded with clean, unborated water.

6.4.2.4 Preferential Flooding

Two different potential conditions of preferential flooding are considered: preferential flooding of the MPC basket itself (i.e. different water levels in different basket cells), and preferential flooding involving Damaged Fuel Containers.

Preferential flooding of the MPC basket itself for any of the MPC fuel basket designs is not possible because flow holes are present on all four walls of each basket cell and on the two flux trap walls at both the top and bottom of the MPC basket. The flow holes are sized to ensure that they cannot be blocked by crud deposits (see Chapter 11). The fuel cladding satisfies the "acceptance criteria to limit spent fuel reconfiguration in storage casks" (ISG-11, Rev. 3), since temperatures remain below their design limits (as demonstrated in Chapter 4). For damaged fuel assemblies and fuel debris, the assemblies or debris are loaded into stainless steel Damaged Fuel Containers fitted with mesh screens which prevent damaged fuel assemblies or fuel debris from blocking the basket flow holes. Therefore, the flow holes cannot be blocked.

However, when DFCs are present in the MPC, a condition could exist during the draining of the MPC, where the DFCs are still partly filled with water while the remainder of the MPC is dry.

HOLTEC INTERNATIONAL COPYRIGHTED MATERIAL

This condition would be the result of the water tension across the mesh screens. The maximum water level inside the DFCs for this condition is calculated from the dimensions of the mesh screen and the surface tension of water. The wetted perimeter of the screen openings is no more than 50 ft per square inch of screen. With a surface tension of water of 0.005 lbf/ft, this results in a maximum pressure across the screen of 0.25 psi, corresponding to a maximum water height in the DFC of 7 inches. For added conservatism, a value of 12 inches is used. Assuming this condition, calculations are performed for all three possible DFC configurations:

- MPC-68 or MPC-68F with 68 DFCs (Assembly Classes 6x6A/B/C, 7x7A and 8x8A)
- MPC-68 with 16 DFCs (All BWR Assembly Classes)
- MPC-24E with 4 DFCs (All PWR Assembly Classes)
- MPC-32 with 8 DFCs (All PWR Assembly Classes)

For each configuration, the case resulting in the highest maximum k_{eff} for the fully flooded condition (see Section 6.4.4) is re-analyzed assuming the preferential flooding condition. For these analyses, the lower 12 inches of the active fuel in the DFCs and the water region below the active fuel (see Figure 6.3.7) are filled with full density water (1.0 g/cc). The remainder of the cask is filled with steam consisting of ordinary water at partial density (0.002 g/cc). Table 6.4.4 lists the maximum k_{eff} for the four configurations in comparison with the maximum k_{eff} for the fully flooded condition. For all configurations, the preferential flooding condition results in a lower maximum k_{eff} than the fully flooded condition. Thus, the preferential flooding condition is bounded by the fully flooded condition.

Once established, the integrity of the MPC confinement boundary is maintained during all credible off-normal and accident conditions, and thus, the MPC cannot be flooded. In summary, it is concluded that the MPC fuel baskets cannot be preferentially flooded, and that the potential preferential flooding conditions involving DFCs are bounded by the result for the fully flooded condition listed in Section 6.4.4.

6.4.2.5 Design Basis Accidents

The analyses presented in Chapters 3 and 11 demonstrate that the damage resulting from the design basis accidents is limited to a loss of the water jacket for the HI-TRAC transfer cask and minor damage to the concrete radiation shield for the HI-STORM storage cask, which have no adverse effect on the design parameters important to criticality safety.

As reported in Chapter 3, Table 3.4.4, the minimum factor of safety for either MPC as a result of the hypothetical cask drop or tip-over accident is 1.1 against the Level D allowables for Subsection NG, Section III of the ASME Code. Therefore, because the maximum box wall stresses are well within the ASME Level D allowables, the flux-trap gap change will be insignificant compared to the characteristic dimension of the flux trap.

HOLTEC INTERNATIONAL COPYRIGHTED MATERIAL

HI-STORM FSAR
REPORT HI-2002444

6.4-5

Rev. 11

In summary, the design basis accidents have no adverse effect on the design parameters important to criticality safety, and therefore, there is no increase in reactivity as a result of any of the credible off-normal or accident conditions involving handling, packaging, transfer or storage. Consequently, the HI-STORM 100 System is in full compliance with the requirement of 10CRF72.124, which states that “before a nuclear criticality accident is possible, at least two unlikely, independent, and concurrent or sequential changes have occurred in the conditions essential to nuclear criticality safety.”

6.4.3 Criticality Results

Results of the design basis criticality safety calculations for the condition of full flooding with water (limiting cases) are presented in section 6.2 and summarized in Section 6.1. To demonstrate the applicability of the HI-STAR analyses, results of the design basis criticality safety calculations for the HI-STAR cask (limiting cases) are also summarized in Section 6.1 for comparison. These data confirm that for each of the candidate fuel types and basket configurations the effective multiplication factor (k_{eff}), including all biases and uncertainties at a 95-percent confidence level, do not exceed 0.95 under all credible normal, off-normal, and accident conditions.

Additional calculations (CASMO-3) at elevated temperatures confirm that the temperature coefficients of reactivity are negative as shown in Table 6.3.1. This confirms that the calculations for the storage baskets are conservative.

In calculating the maximum reactivity, the analysis used the following equation:

$$k_{eff}^{max} = k_c + K_c \sigma_c + Bias + \sigma_B$$

where:

- ⇒ k_c is the calculated k_{eff} under the worst combination of tolerances;
- ⇒ K_c is the K multiplier for a one-sided statistical tolerance limit with 95% probability at the 95% confidence level [6.1.8]. Each final k_{eff} value calculated by MCNP4a (or KENO5a) is the result of averaging 100 (or more) cycle k_{eff} values, and thus, is based on a sample size of 100. The K multiplier corresponding to a sample size of 100 is 1.93. However, for this analysis a value of 2.00 was assumed for the K multiplier, which is larger (more conservative) than the value corresponding to a sample size of 100;
- ⇒ σ_c is the standard deviation of the calculated k_{eff} , as determined by the computer code (MCNP4a or KENO5a);
- ⇒ *Bias* is the systematic error in the calculations (code dependent) determined by comparison with critical experiments in Appendix 6.A; and
- ⇒ σ_B is the standard error of the bias (which includes the K multiplier for 95% probability at the 95% confidence level; see Appendix 6.A).

HOLTEC INTERNATIONAL COPYRIGHTED MATERIAL

The critical experiment benchmarking and the derivation of the bias and standard error of the bias (95% probability at the 95% confidence level) are presented in Appendix 6.A.

6.4.4 Damaged Fuel and Fuel Debris

Damaged fuel assemblies and fuel debris are required to be loaded into Damaged Fuel Containers (DFCs). Five (5) different DFC types with different cross sections are analyzed. Three (3) of these DFCs are designed for BWR fuel assemblies, two (2) are designed for PWR fuel assemblies. Two of the DFCs for BWR fuel are specifically designed for fuel assembly classes 6x6A, 6x6B, 6x6C, 7x7A and 8x8A. These assemblies have a smaller cross section, a shorter active length and a low initial enrichment of 2.7 wt% ²³⁵U, and therefore a low reactivity. The analysis for these assembly classes is presented in the following Section 6.4.4.1. The remaining three DFCs are generic DFCs designed for all BWR and PWR assembly classes. The criticality analysis for these generic DFCs is presented in Section 6.4.4.2.

6.4.4.1 MPC-68 or MPC-68F loaded with Assembly Classes 6x6A, 6x6B, 6x6C, 7x7A and 8x8A

This section only addresses criticality calculations and results for assembly classes 6x6A, 6x6B, 6x6C, 7x7A and 8x8A, loaded into the MPC-68 or MPC-68F. Up to 68 DFCs with these assembly classes are permissible to be loaded into the MPC. Two different DFC types with slightly different cross-sections are analyzed. Evaluation of the capability of storing damaged fuel and fuel debris (loaded in DFCs) is limited to very low reactivity fuel in the MPC-68F. Because the MPC-68 has a higher specified ¹⁰B loading, the evaluation of the MPC-68F conservatively bounds the storage of damaged BWR fuel assemblies in a standard MPC-68. Although the maximum planar-average enrichment of the damaged fuel is limited to 2.7% ²³⁵U as specified in Section 2.1.9, analyses have been made for three possible scenarios, conservatively assuming fuel^{††} of 3.0% enrichment. The scenarios considered included the following:

1. Lost or missing fuel rods, calculated for various numbers of missing rods in order to determine the maximum reactivity. The configurations assumed for analysis are illustrated in Figures 6.4.2 through 6.4.8.
2. Broken fuel assembly with the upper segments falling into the lower segment creating a close-packed array (described as a 8x8 array). For conservatism, the array analytically retained the same length as the original fuel assemblies in this

†† 6x6A01 and 7x7A01 fuel assemblies were used as representative assemblies.

- analysis. This configuration is illustrated in Figure 6.4.9.
3. Fuel pellets lost from the assembly and forming powdered fuel dispersed through a volume equivalent to the height of the original fuel. (Flow channel and clad material assumed to disappear).

Results of the analyses, shown in Table 6.4.5, confirm that, in all cases, the maximum reactivity is well below the regulatory limit. There is no significant difference in reactivity between the two DFC types. Collapsed fuel reactivity (simulating fuel debris) is low because of the reduced moderation. Dispersed powdered fuel results in low reactivity because of the increase in ^{238}U neutron capture (higher effective resonance integral for ^{238}U absorption).

The loss of fuel rods results in a small increase in reactivity (i.e., rods assumed to collapse, leaving a smaller number of rods still intact). The peak reactivity occurs for 8 missing rods, and a smaller (or larger) number of intact rods will have a lower reactivity, as indicated in Table 6.4.5.

The analyses performed and summarized in Table 6.4.5 provide the relative magnitude of the effects on the reactivity. This information coupled with the maximum k_{eff} values listed in Table 6.1.3 and the conservatism in the analyses, demonstrates that the maximum k_{eff} of the damaged fuel in the most adverse post-accident condition will remain well below the regulatory requirement of $k_{\text{eff}} < 0.95$.

6.4.4.2 Generic BWR and PWR Damaged Fuel and Fuel Debris

The MPC-24E, MPC-32, and MPC-68 are designed to contain PWR and BWR damaged fuel and fuel debris, loaded into generic DFCs. The number of generic DFCs is limited to 16 for the MPC-68, to 4 for the MPC-24E, and to 8 for the MPC-32. The permissible locations of the DFCs are shown in Figure 6.4.11 for the MPC-68, in Figure 6.4.12 for the MPC-24E and in Figure 6.4.16 for the MPC-32.

Damaged fuel assemblies are assemblies with known or suspected cladding defects greater than pinholes or hairlines, or with missing rods, but excluding fuel assemblies with gross defects (for a full definition see Table 1.0.1). Therefore, apart from possible missing fuel rods, damaged fuel assemblies have the same geometric configuration as intact fuel assemblies and consequently the same reactivity. Missing fuel rods can result in a slight increase of reactivity. After a drop accident, however, it can not be assumed that the initial geometric integrity is still maintained. For a drop on either the top or bottom of the cask, the damaged fuel assemblies could collapse. This would result in a configuration with a reduced length, but increased amount of fuel per unit length. For a side drop, fuel rods could be compacted to one side of the DFC. In either case, a significant relocation of fuel within the DFC is possible, which creates a greater amount of fuel in some areas of the DFC, whereas the amount of fuel in other areas is reduced. Fuel debris can include a large variety of configurations ranging from whole fuel assemblies with severe damage down to individual fuel pellets.

HOLTEC INTERNATIONAL COPYRIGHTED MATERIAL

In the cases of fuel debris or relocated damaged fuel, there is the potential that fuel could be present in axial sections of the DFCs that are outside the basket height covered with the fixed neutron absorber. However, in these sections, the DFCs are not surrounded by any intact fuel, only by basket cell walls, non-fuel hardware, and water and for the MPC-68 by a maximum of one other DFC. Studies have shown that this condition does not result in any significant effect on reactivity, compared to a condition where the damaged fuel and fuel debris is restricted to the axial section of the basket covered by the fixed neutron absorber. All calculations for generic BWR and PWR damaged fuel and fuel debris are therefore performed assuming that fuel is present only in the axial sections covered by the fixed neutron absorber, and the results are directly applicable to any situation where damaged fuel and fuel debris is located outside these sections in the DFCs.

To address all the situations listed above and identify the configuration or configurations leading to the highest reactivity, it is impractical to analyze a large number of different geometrical configurations for each of the fuel classes. Instead, a bounding approach is taken which is based on the analysis of regular arrays of bare fuel rods without cladding. Details and results of the analyses are discussed in the following sections.

All calculations for generic damaged fuel and fuel debris are performed using a full cask model with the maximum permissible number of Damaged Fuel Containers. For the MPC-68, the model therefore contains 52 intact assemblies, and 16 DFCs in the locations shown in Figure 6.4.11. For the MPC-24E, the model consists of 20 intact assemblies, and 4 DFCs in the locations shown in Figure 6.4.12. For the MPC-32, the model consists of 24 intact assemblies, and 8 DFCs in the locations shown in Figure 6.4.16. The bounding assumptions regarding the intact assemblies and the modeling of the damaged fuel and fuel debris in the DFCs are discussed in the following sections.

Note that since a modeling approach is used that bounds both damaged fuel and fuel debris without distinguishing between these two conditions, the term 'damaged fuel' as used throughout this chapter designates both damaged fuel and fuel debris.

6.4.4.2.1 Bounding Intact Assemblies

Intact BWR assemblies stored together with DFCs are limited to a maximum planar average enrichment of 3.7 wt% ^{235}U , regardless of the fuel class. The results presented in Table 6.1.7 are for different enrichments for each class, ranging between 2.7 and 4.2 wt% ^{235}U , making it difficult to identify the bounding assembly. Therefore, additional calculations were performed for the bounding assembly in each assembly class with a planar average enrichment of 3.7 wt%. The results are summarized in Table 6.4.7 and demonstrate that the assembly classes 9x9E and 9x9F have the highest reactivity. These two classes share the same bounding assembly (see footnotes for Tables 6.2.33 and 6.2.34 for further details). This bounding assembly is used as the intact BWR assembly for all calculations with DFCs.

Intact PWR assemblies stored together with DFCs in the MPC-24E are limited to a maximum enrichment of 4.0 wt% ^{235}U without credit for soluble boron and to a maximum enrichment of 5.0 wt% with credit for soluble boron, regardless of the fuel class. The results presented in Table 6.1.3 are for different enrichments for each class, ranging between 4.2 and 5.0 wt% ^{235}U , making it difficult to directly identify the bounding assembly. However, Table 6.1.4 shows results for an enrichment of 5.0 wt% for all fuel classes, with a soluble boron concentration of 300 ppm. The assembly class 15x15H has the highest reactivity. This is consistent with the results in Table 6.1.3, where the assembly class 15x15H is among the classes with the highest reactivity, but has the lowest initial enrichment. Therefore, in the MPC-24E, the 15x15H assembly is used as the intact PWR assembly for all calculations with DFCs.

Intact PWR assemblies stored together with DFCs in the MPC-32 are limited to a maximum enrichment of 5.0 wt%, regardless of the fuel class. Table 6.1.5 and Table 6.1.6 show results for enrichments of 4.1 wt% and 5.0 wt%, respectively, for all fuel classes. Since different minimum soluble boron concentrations are used for different groups of assembly classes, the assembly class with the highest reactivity in each group is used as the intact assembly for the calculations with DFCs in the MPC-32. These assembly classes are

- 14x14C for all 14x14 assembly classes;
- 15x15B for assembly classes 15x15A, B, C, G and I;
- 15x15F for assembly classes 15x15D, E, F and H;
- 16x16A; and
- 17x17C for all 17x17 assembly classes.

6.4.4.2.2 Bare Fuel Rod Arrays

A conservative approach is used to model both damaged fuel and fuel debris in the DFCs, using arrays of bare fuel rods:

- Fuel in the DFCs is arranged in regular, rectangular arrays of bare fuel rods, i.e. all cladding and other structural material in the DFC is replaced by water.
- For cases with soluble boron, additional calculations are performed with reduced water density in the DFC. This is to demonstrate that replacing all cladding and other structural material with borated water is conservative.
- The active length of these rods is chosen to be the maximum active fuel length of all fuel assemblies listed in Section 6.2, which is 155 inch for BWR fuel and 150 inch for PWR fuel.
- To ensure the configuration with optimum moderation and highest reactivity is analyzed, the amount of fuel per unit length of the DFC is varied over a large range. This is achieved by changing the number of rods in the array and the rod pitch. The number of rods are varied

HOLTEC INTERNATIONAL COPYRIGHTED MATERIAL

between 9 (3x3) and 189 (17x17) for BWR fuel, and between 64 (8x8) and 729 (27x27) for PWR fuel.

- Analyses are performed for the minimum, maximum and typical pellet diameter of PWR and BWR fuel.

This is a very conservative approach to model damaged fuel, and to model fuel debris configurations such as severely damaged assemblies and bundles of individual fuel rods, as the absorption in the cladding and structural material is neglected.

This is also a conservative approach to model fuel debris configurations such as bare fuel pellets due to the assumption of an active length of 155 inch (BWR) or 150 inch (PWR). The actual height of bare fuel pellets in a DFC would be significantly below these values due to the limitation of the fuel mass for each basket position.

To demonstrate the level of conservatism, additional analyses are performed with the DFC containing various realistic assembly configurations such as intact assemblies, assemblies with missing fuel rods and collapsed assemblies, i.e. assemblies with increased number of rods and decreased rod pitch.

As discussed in Section 6.4.4.2, all calculations are performed for full cask models, containing the maximum permissible number of DFCs together with intact assemblies.

As an example of the damaged fuel model used in the analyses, Figure 6.4.17 shows the basket cell of an MPC-32 with a DFC containing a 17x17 array of bare fuel rods.

Graphical presentations of the calculated maximum k_{eff} for typical cases as a function of the fuel mass per unit length of the DFC are shown in Figures 6.4.13 (BWR) and 6.4.14 (PWR, MPC-24E with pure water). The results for the bare fuel rods show a distinct peak in the maximum k_{eff} at about 2 kg UO₂/inch for BWR fuel, and at about 3.5 kgUO₂/inch for PWR fuel.

The realistic assembly configurations are typically about 0.01 (delta-k) or more below the peak results for the bare fuel rods, demonstrating the conservatism of this approach to model damaged fuel and fuel debris configurations such as severely damaged assemblies and bundles of fuel rods.

For fuel debris configurations consisting of bare fuel pellets only, the fuel mass per unit length would be beyond the value corresponding to the peak reactivity. For example, for DFCs filled with a mixture of 60 vol% fuel and 40 vol% water the fuel mass per unit length is 3.36 kgUO₂/inch for the BWR DFC and 7.92 kgUO₂/inch for the PWR DFC. The corresponding reactivities are significantly below the peak reactivity. The difference is about 0.005 (delta-k) for BWR fuel and 0.01 (delta-k) or more for PWR fuel. Furthermore, the filling height of the DFC

HOLTEC INTERNATIONAL COPYRIGHTED MATERIAL

would be less than 70 inches in these examples due to the limitation of the fuel mass per basket position, whereas the calculation is conservatively performed for a height of 155 inch (BWR) or 150 inch (PWR). These results demonstrate that even for the fuel debris configuration of bare fuel pellets, the model using bare fuel rods is a conservative approach.

6.4.4.2.3 Distributed Enrichment in BWR Fuel

BWR fuel usually has an enrichment distribution in each planar cross section, and is characterized by the maximum planar average enrichment. For intact fuel it has been shown that using the average enrichment for each fuel rod in a cross section is conservative, i.e. the reactivity is higher than calculated for the actual enrichment distribution (See Appendix 6.B). For damaged fuel assemblies, additional configurations are analyzed to demonstrate that the distributed enrichment does not have a significant impact on the reactivity of the damaged assembly under accident conditions. Specifically, the following two scenarios were analyzed:

- As a result of an accident, fuel rods with lower enrichment relocate from the top part to the bottom part of the assembly. This results in an increase of the average enrichment in the top part, but at the same time the amount of fuel in that area is reduced compared to the intact assembly.
- As a result of an accident, fuel rods with higher enrichment relocate from the top part to the bottom part of the assembly. This results in an increase of the average enrichment in the bottom part, and at the same time the amount of fuel in that area is increased compared to the intact assembly, leading to a reduction of the water content.

In both scenarios, a compensation of effects on reactivity is possible, as the increase of reactivity due to the increased planar average enrichment might be offset by the possible reduction of reactivity due to the change in the fuel to water ratio. A selected number of calculations have been performed for these scenarios and the results show that there is only a minor change in reactivity. These calculations are shown in Figure 6.4.13 in the group of the explicit assemblies. Consequently, it is appropriate to qualify damaged BWR fuel assemblies and fuel debris based on the maximum planar average enrichment. For assemblies with missing fuel rods, this maximum planar average enrichment has to be determined based on the enrichment and number of rods still present in the assembly when loaded into the DFC.

6.4.4.2.4 Results for the MPC-68

The MPC-68 allows the storage of up to sixteen DFCs in the shaded cells on the periphery of the basket shown in Figure 6.4.11. Additionally, up to 8 of these cells may contain DFCs with fuel debris. The various configurations outlined in Sections 6.4.4.2.2 and 6.4.4.2.3 are analyzed with an enrichment of the intact fuel of 3.7% ²³⁵U and an enrichment of damaged fuel or fuel debris of 4.0% ²³⁵U. For the intact assembly, the bounding assembly of the 9x9E and 9x9F fuel classes was chosen. This assembly has the highest reactivity of all BWR assembly classes for the initial

HOLTEC INTERNATIONAL COPYRIGHTED MATERIAL

enrichment of 3.7 wt% ^{235}U , as demonstrated in Table 6.4.7. The results for the various configurations are summarized in Figure 6.4.13 and in Table 6.4.8. Figure 6.4.13 shows the maximum k_{eff} , including bias and calculational uncertainties, for various actual and hypothetical damaged fuel or fuel debris configurations as a function of the fuel mass per unit length of the DFC. Table 6.4.8 lists the highest maximum k_{eff} for the various configurations. All maximum k_{eff} values are below the 0.95 regulatory limit.

6.4.4.2.5 Results for the MPC-24E

The MPC-24E allows the storage of up to four DFCs with damaged fuel or fuel debris in the four outer fuel baskets cells shaded in Figure 6.4.12. These locations are designed with a larger box ID to accommodate the DFCs. For an enrichment of 4.0 wt% ^{235}U for the intact fuel, damaged fuel and fuel debris, and assuming no soluble boron, the results for the various configurations outlined in Section 6.4.4.2.2 are summarized in Figure 6.4.14 and in Table 6.4.9. Figure 6.4.14 shows the maximum k_{eff} , including bias and calculational uncertainties, for various actual and hypothetical damaged fuel and fuel debris configurations as a function of the fuel mass per unit length of the DFC. For the intact assemblies, the 15x15H assembly class was chosen. This assembly class has the highest reactivity of all PWR assembly classes for a given initial enrichment. This is demonstrated in Table 6.1.4. Table 6.4.9 lists the highest maximum k_{eff} for the various configurations. All maximum k_{eff} values are below the 0.95 regulatory limit.

For an enrichment of 5.0 wt% ^{235}U for the intact fuel, damaged fuel and fuel debris, a minimum soluble boron concentration of 600 ppm is required. For this condition, calculations are performed for various hypothetical fuel debris configurations (i.e. bare fuel rods) as a function of the fuel mass per unit length of the DFC. Additionally, calculations are performed with reduced water densities in the DFC. The various conditions of damaged fuel, such as assemblies with missing rods or collapsed assemblies, were not analyzed, since the results in Figure 6.4.14 clearly demonstrate that these conditions are bounded by the hypothetical model for fuel debris based on regular arrays of bare fuel rods. Again, the 15x15H assembly class was chosen as the intact assembly since this assembly class has the highest reactivity of all PWR assembly classes as demonstrated in Table 6.1.4. The results are summarized in Table 6.4.12. Similar to the calculations with pure water (see Figure 6.4.14), the results for borated water show a distinct peak of the maximum k_{eff} as a function of the fuel mass per unit length. Therefore, for each condition, the table lists only the highest maximum k_{eff} , including bias and calculational uncertainties, i.e. the point of optimum moderation. The results show that the reactivity decreases with decreasing water density. This demonstrates that replacing all cladding and other structural material with water is conservative even in the presence of soluble boron in the water. All maximum k_{eff} values are below the 0.95 regulatory limit.

6.4.4.2.6 Results for the MPC-32

The MPC-32 allows the storage of up to eight DFCs with damaged fuel or fuel debris in the outer

HOLTEC INTERNATIONAL COPYRIGHTED MATERIAL

fuel basket cells shaded in Figure 6.4.16. For the MPC-32, additional cases are analyzed due to the high soluble boron level required for this basket:

- The assembly classes of the intact assemblies are grouped, and minimum required soluble boron levels are determined separately for each group. The analyses are performed for the bounding assembly class in each group. The bounding assembly classes are listed in Section 6.4.4.2.1.
- Evaluations of conditions with voided and filled guide tubes and various water densities in the MPC and DFC are performed to identify the most reactive condition.

In general, all calculations performed for the MPC-32 show the same principal behavior as for the MPC-24 (see Figure 6.4.14), i.e. the reactivity as a function of the fuel mass per unit length for the bare fuel rod array shows a distinct peak. Therefore, for each condition analyzed, only the highest maximum k_{eff} , i.e. the calculated peak reactivity, is listed in the tables. Evaluations of different diameters of the bare fuel pellets and the reduced water density in the DFC have been performed for a representative case using the 15x15F assembly class as the intact assembly, with voided guide tubes, a water density of 1.0 g/cc in the DFC and MPC, 2900 ppm soluble boron, and an enrichment of 5.0 wt% ^{235}U for the intact and damaged fuel and fuel debris. For this case, results are summarized in Table 6.4.13. For each condition, the table lists the highest maximum k_{eff} , including bias and calculational uncertainties, i.e. the point of optimum moderation. The results show that the fuel pellet diameter in the DFC has an insignificant effect on reactivity, and that reactivity decreases with decreasing water density. The latter demonstrates that replacing all cladding and other structural material with water is conservative even in the presence of soluble boron in the water. Therefore, a typical fuel pellet diameter and a water density of 1.0 in the DFCs are used for all further analyses. Two enrichment levels are analyzed, 4.1 wt% ^{235}U and 5.0 wt% ^{235}U , consistent with the analyses for intact fuel only. In any calculation, the same enrichment is used for the intact fuel and the damaged fuel and fuel debris. For both enrichment levels, analyses are performed with voided and filled guide tubes, each with water densities of 0.93 and 1.0 g/cm³ in the MPC. In all cases, the water density inside the DFCs is assumed to be 1.0 g/cm³, since this is the most reactive condition as shown in Table 6.4.13. Results are summarized in Table 6.4.14. For each group of assembly classes, the table shows the soluble boron level and the highest maximum k_{eff} for the various moderation conditions of the intact assembly. The highest maximum k_{eff} is the highest value of any of the hypothetical fuel debris configurations, i.e. various arrays of bare fuel rods. All maximum k_{eff} values are below the 0.95 regulatory limit. Conditions of damaged fuel such as assemblies with missing rods or collapsed assemblies were not analyzed in the MPC-32, since the results in Figure 6.4.14 clearly demonstrate that these conditions are bounded by the hypothetical model for fuel debris based on regular arrays of bare fuel rods.

HOLTEC INTERNATIONAL COPYRIGHTED MATERIAL

HI-STORM FSAR
REPORT HI-2002444

6.4-14

Rev. 11

6.4.5 Fuel Assemblies with Missing Rods

For fuel assemblies that are qualified for damaged fuel storage, missing and/or damaged fuel rods are acceptable. However, for fuel assemblies to meet the limitations of intact fuel assembly storage, missing fuel rods must be replaced with dummy rods that displace a volume of water that is equal to, or larger than, that displaced by the original rods.

6.4.6 Thoria Rod Canister

The Thoria Rod Canister is similar to a DFC with an internal separator assembly containing 18 intact fuel rods. The configuration is illustrated in Figure 6.4.15. The k_{eff} value for an MPC-68F filled with Thoria Rod Canisters is calculated to be 0.1813. This low reactivity is attributed to the relatively low content in ^{235}U (equivalent to UO_2 fuel with an enrichment of approximately 1.7 wt% ^{235}U), the large spacing between the rods (the pitch is approximately 1", the cladding OD is 0.412") and the absorption in the separator assembly. Together with the maximum k_{eff} values listed in Tables 6.1.7 and 6.1.8 this result demonstrates, that the k_{eff} for a Thoria Rod Canister loaded into the MPC-68 or the MPC-68F together with other approved fuel assemblies or DFCs will remain well below the regulatory requirement of $k_{eff} < 0.95$.

6.4.7 Sealed Rods replacing BWR Water Rods

Some BWR fuel assemblies contain sealed rods filled with a non-fissile material instead of water rods. Compared to the configuration with water rods, the configuration with sealed rods has a reduced amount of moderator, while the amount of fissile material is maintained. Thus, the reactivity of the configuration with sealed rods will be lower compared to the configuration with water rods. Any configuration containing sealed rods instead of water rods is therefore bounded by the analysis for the configuration with water rods and no further analysis is required to demonstrate the acceptability. Therefore, for all BWR fuel assemblies analyzed, it is permissible that water rods are replaced by sealed rods filled with a non-fissile material.

6.4.8 Non-fuel Hardware in PWR Fuel Assemblies

Non-fuel hardware such as Thimble Plugs (TPs), Burnable Poison Rod Assemblies (BPRAs), Control Rod Assemblies (CRAs), Axial Power Shaping Rods (APSRs) and similar devices are permitted for storage with all PWR fuel types. Non-fuel hardware is inserted in the guide tubes of the assemblies. For pure water, the reactivity of any PWR assembly with inserts is bounded by (i.e. lower than) the reactivity of the same assembly without the insert. This is due to the fact that the insert reduces the amount of moderator in the assembly, while the amount of fissile material remains unchanged. This conclusion is supported by the calculation listed in Table 6.2.4, which

HOLTEC INTERNATIONAL COPYRIGHTED MATERIAL

shows a significant reduction in reactivity as a result of voided guide tubes, i.e. the removal of the water from the guide tubes.

With the presence of soluble boron in the water, non-fuel hardware not only displaces water, but also the neutron absorber in the water. It is therefore possible that the insertion results in an increase of reactivity, specifically for higher soluble boron concentrations. As a bounding approach for the presence of non-fuel hardware, analyses were performed with empty (voided) guide tubes, i.e. any absorption of the hardware is neglected. If assemblies contain an instrument tube, this tube remains filled with borated water. Table 6.4.6 shows results for the variation in water density for cases with filled and voided guide tubes. These results show that the optimum moderator density depends on the soluble boron concentration, and on whether the guide tubes are filled or assumed empty. For the MPC-24 with 400 ppm and the MPC-32 with 1900 ppm, voiding the guide tubes results in a reduction of reactivity. All calculations for the MPC-24 and MPC-24E are therefore performed with water in the guide tubes. For the MPC-32 with 2600 ppm, the reactivity for voided guide tubes slightly exceeds the reactivity for filled guide tubes. However, this effect is not consistent across all assembly classes. Table 6.4.10, Table 6.4.11 and Table 6.4.14 show results with filled and voided guide tubes for all assembly classes in the MPC-32 at 4.1 wt% ^{235}U and 5.0 wt% ^{235}U . Some classes show an increase, other classes show a decrease as a result of voiding the guide tubes. Therefore, for the results presented in the Section 6.1, Table 6.1.5, Table 6.1.6 and Table 6.1.12, the maximum value for each class is chosen for each enrichment level.

An Instrument Tube Tie Rod (ITTR) is inserted into the instrument tube and is permitted for storage with all PWR assemblies. Studies for representative PWR assemblies, including the assembly with the lowest margin (15x15F in the MPC-32), with voided instrument tubes confirm that this condition is equivalent to or bounded by the condition with flooded instrument tubes. An ITTR in the assembly instrument tube is therefore acceptable in all PWR assembly types, and all results and conclusions for PWR fuel assemblies without an ITTR are directly applicable to PWR assemblies with an ITTR.

In summary, from a criticality safety perspective, non-fuel hardware inserted into PWR assemblies are acceptable for all allowable PWR types, and, depending on the assembly class, can increase the safety margin.

6.4.9 Neutron Sources in Fuel Assemblies

Fuel assemblies containing start-up neutron sources are permitted for storage in the HI-STORM 100 System. The reactivity of a fuel assembly is not affected by the presence of a neutron source (other than by the presence of the material of the source, which is discussed later). This is true because in a system with a keff less than 1.0, any given neutron population at any time, regardless of its origin or size, will decrease over time. Therefore, a neutron source of any strength will not increase reactivity, but only the neutron flux in a system, and no additional

HOLTEC INTERNATIONAL COPYRIGHTED MATERIAL

criticality analyses are required. Sources are inserted as rods into fuel assemblies, i.e. they replace either a fuel rod or water rod (moderator). Therefore, the insertion of the material of the source into a fuel assembly will not lead to an increase of reactivity either.

6.4.10 Applicability of HI-STAR Analyses to HI-STORM 100 System

Calculations previously supplied to the NRC in applications for the HI-STAR 100 System (Docket Numbers 71-9261 and 72-1008) are directly applicable to the HI-STORM storage and HI-TRAC transfer casks. The MPC designs are identical. The cask systems differ only in the overpack shield material. The limiting condition for the HI-STORM 100 System is the fully flooded HI-TRAC transfer cask. As demonstrated by the comparative calculations presented in Tables 6.1.1 through 6.1.8, the shield material in the overpack (steel and lead for HI-TRAC, steel for HI-STAR) has a negligible impact on the eigenvalue of the cask systems. As a result, this analysis for the 125-ton HI-TRAC transfer cask is applicable to the 100-ton HI-TRAC transfer cask. In all cases, for the reference fuel assemblies, the maximum k_{eff} values are in good agreement and are conservatively less than the limiting k_{eff} value (0.95).

6.4.11 Fixed Neutron Absorber Material

The MPCs in the HI-STORM 100 System can be manufactured with one of two possible neutron absorber materials: Boral or Metamic. Both materials are made of aluminum and B_4C powder. Boral has an inner core consisting of B_4C and aluminum between two outer layers consisting of aluminum only. This configuration is explicitly modeled in the criticality evaluation and shown in Figures 6.3.1 through 6.3.3 for each basket. Metamic is a single layer material with a slightly higher overall thickness and the same credited ^{10}B loading (in g/cm^2) for each basket. The majority of the criticality evaluations documented in this chapter are performed using Boral as the fixed neutron absorber. For a selected number of bounding cases, analyses are also performed using Metamic instead of Boral. (Note that the Metamic cases use the same absorber thickness as the corresponding Boral case, instead of the slightly increased thickness for Metamic. This is acceptable since analyses of slight thickness increases for a fixed ^{10}B loading (in g/cm^2) indicate that such increases have a negligible effect on reactivity.) The results for these cases are listed in Table 6.4.15, together with the corresponding result using Boral and the difference between the two materials for each case. Individual cases show small differences for the two materials. However, the differences are mostly below two times the standard deviation (the standard deviation is about 0.0008 for all cases in Table 6.4.15), indicating that the results are statistically equivalent. Furthermore, the average difference is well below one standard deviation, and all cases are below the regulatory limit of 0.95. In some cases listed in Table 6.4.15, the reactivity difference between Metamic and Boral might be larger than expected for two equivalent materials. Also, for four out of the five cases with MPC-24 type baskets, Metamic shows the higher reactivity, which could potentially indicate a trend rather than a statistical variation. Therefore, in order to confirm that the materials are equivalent, a second set of calculations was

HOLTEC INTERNATIONAL COPYRIGHTED MATERIAL

performed for Metamic, which was statistically independent from the set shown in Table 6.4.15. This was achieved by selecting a different starting value for the random number generator in the Monte Carlo calculations. The second set also shows some individual variations of the differences, and a low average difference. However, there is no apparent trend regarding the MPC-24 type baskets compared to the MPC-32 and MPC-68, and the maximum positive reactivity difference for Metamic in an MPC-24 type basket is only 0.0005. Overall, the calculations demonstrate that the two fixed neutron absorber materials are identical from a criticality perspective. All results obtained for Boral are therefore directly applicable to Metamic and no further evaluations using Metamic are required.

6.4.12 Annular Fuel Pellets

Typically, PWR fuel assemblies are designed with solid fuel pellets throughout the entire active fuel length. However, some PWR assemblies contain annular fuel pellets in the top and bottom 6 to 8 inches of the active fuel length. This changes the fuel to water ratio in these areas, which could have an effect on reactivity. However, the top and bottom of the active length are areas with high neutron leakage, and changes in these areas typically have no significant effect on reactivity. Studies with up to 12 inches of annular pellets at the top and bottom, with various pellet IDs confirm this, i.e., shown no significant reactivity effects, even if the annular region of the pellet is flooded with pure water. All calculations for PWR fuel assemblies are therefore performed with solid fuel pellets along the entire length of the active fuel region, and the results are directly applicable to those PWR assemblies with annular fuel pellets.

HOLTEC INTERNATIONAL COPYRIGHTED MATERIAL

HI-STORM FSAR
REPORT HI-2002444

6.4-18

Rev. 11

Table 6.4.1

MAXIMUM REACTIVITIES WITH REDUCED WATER DENSITIES FOR CASK ARRAYS[†]

Case Number	Water Density		MCNP4a Maximum k_{eff} ^{††}	
	Internal	External	MPC-24 (17x17A01 @ 4.0%)	MPC-68 (8x8C04 @ 4.2%)
1	100%	single cask	0.9368	0.9348
2	100%	100%	0.9354	0.9339
3	100%	70%	0.9362	0.9339
4	100%	50%	0.9352	0.9347
5	100%	20%	0.9372	0.9338
6	100%	10%	0.9380	0.9336
7	100%	5%	0.9351	0.9333
8	100%	0%	0.9342	0.9338
9	70%	0%	0.8337	0.8488
10	50%	0%	0.7426	0.7631
11	20%	0%	0.5606	0.5797
12	10%	0%	0.4834	0.5139
13	5%	0%	0.4432	0.4763
14	10%	100%	0.4793	0.4946

[†] For an infinite square array of casks with 60cm spacing between cask surfaces.

^{††} Maximum k_{eff} includes the bias, uncertainties, and calculational statistics, evaluated for the worst case combination of manufacturing tolerances.

HOLTEC INTERNATIONAL COPYRIGHTED MATERIAL

HI-STORM FSAR
REPORT HI-2002444

6.4-19

Rev. 11

Table 6.4.2

REACTIVITY EFFECTS OF PARTIAL CASK FLOODING

MPC-24 (17x17A01 @ 4.0% ENRICHMENT) (no soluble boron)			
Flooded Condition (% Full)	Vertical Orientation	Flooded Condition (% Full)	Horizontal Orientation
25	0.9157	25	0.8766
50	0.9305	50	0.9240
75	0.9330	75	0.9329
100	0.9368	100	0.9368
MPC-68 (8x8C04 @ 4.2% ENRICHMENT)			
Flooded Condition (% Full)	Vertical Orientation	Flooded Condition (% Full)	Horizontal Orientation
25	0.9132	23.5	0.8586
50	0.9307	50	0.9088
75	0.9312	76.5	0.9275
100	0.9348	100	0.9348
MPC-32 (15x15F @ 5.0 % ENRICHMENT) 2600ppm Soluble Boron			
Flooded Condition (% Full)	Vertical Orientation	Flooded Condition (% Full)	Horizontal Orientation
25	0.8927	31.25	0.9213
50	0.9215	50	0.9388
75	0.9350	68.75	0.9401
100	0.9445	100	0.9445

Notes:

1. All values are maximum k_{eff} which include bias, uncertainties, and calculational statistics, evaluated for the worst case combination of manufacturing tolerances.

HOLTEC INTERNATIONAL COPYRIGHTED MATERIAL

HI-STORM FSAR
REPORT HI-2002444

6.4-20

Rev. 11

Table 6.4.3

REACTIVITY EFFECT OF FLOODING THE PELLETT-TO-CLAD GAP

Pellet-to-Clad Condition	MPC-24 17x17A01 4.0% Enrichment	MPC-68 8x8C04 4.2% Enrichment
dry	0.9295	0.9279
flooded with unborated water	0.9368	0.9348

Notes:

1. All values are maximum k_{eff} which includes bias, uncertainties, and calculational statistics, evaluated for the worst case combination of manufacturing tolerances.

HOLTEC INTERNATIONAL COPYRIGHTED MATERIAL

HI-STORM FSAR
REPORT HI-2002444

6.4-21

Rev. 11

Table 6.4.4

REACTIVITY EFFECT OF PREFERENTIAL FLOODING OF THE DFCs

DFC Configuration	Preferential Flooding	Fully Flooded
MPC-68 or MPC-68F with 68 DFCs (Assembly Classes 6x6A/B/C, 7x7A and 8x8A)	0.6560	0.7857
MPC-68 with 16 DFCs (All BWR Assembly Classes)	0.6646	0.9328
MPC-24E with 4 DFCs (All PWR Assembly Classes)	0.7895	0.9480
MPC-32 with 8 DFCs (All PWR Assembly Classes)	0.7213	0.9378

Notes:

1. All values are maximum k_{eff} which includes bias, uncertainties, and calculational statistics, evaluated for the worst case combination of manufacturing tolerances.

HOLTEC INTERNATIONAL COPYRIGHTED MATERIAL

HI-STORM FSAR
REPORT HI-2002444

6.4-22

Rev. 11

Table 6.4.5

MAXIMUM k_{eff} VALUES[†] IN THE DAMAGED FUEL CONTAINER

Condition	MCNP4a Maximum ^{††} k_{eff}	
	DFC Dimensions: ID 4.93" THK. 0.12"	DFC Dimensions: ID 4.81" THK. 0.11"
<u>6x6 Fuel Assembly</u>		
6x6 Intact Fuel	0.7086	0.7016
w/32 Rods Standing	0.7183	0.7117
w/28 Rods Standing	0.7315	0.7241
w/24 Rods Standing	0.7086	0.7010
w/18 Rods Standing	0.6524	0.6453
Collapsed to 8x8 array	0.7845	0.7857
Dispersed Powder	0.7628	0.7440
<u>7x7 Fuel Assembly</u>		
7x7 Intact Fuel	0.7463	0.7393
w/41 Rods Standing	0.7529	0.7481
w/36 Rods Standing	0.7487	0.7444
w/25 Rods Standing	0.6718	0.6644

[†] These calculations were performed with a planar-average enrichment of 3.0% and a ¹⁰B loading of 0.0067 g/cm², which is 75% of a minimum ¹⁰B loading of 0.0089 g/cm². The minimum ¹⁰B loading in the MPC-68F is 0.010 g/cm². Therefore, the listed maximum k_{eff} values are conservative

^{††} Maximum k_{eff} includes bias, uncertainties, and calculational statistics, evaluated for the worst case combination of manufacturing tolerances.

HOLTEC INTERNATIONAL COPYRIGHTED MATERIAL

HI-STORM FSAR
REPORT HI-2002444

6.4-23

Rev. 11

Table 6.4.6

MAXIMUM k_{eff} VALUES WITH REDUCED BORATED WATER DENSITIES

Internal Water Density [†] in g/cm ³	Maximum k_{eff}				
	MPC-24 (400ppm) @ 5.0 %	MPC-32 (1900ppm) @ 4.1 %		MPC-32 (2600ppm) @ 5.0 %	
Guide Tubes	filled	filled	void	filled	void
1.005	NC ^{††}	0.9403	0.9395	NC	0.9481
1.00	0.9314	0.9411	0.9400	0.9445	0.9483
0.99	NC	0.9393	0.9396	0.9438	0.9462
0.98	0.9245	0.9403	0.9376	0.9447	0.9465
0.97	NC	0.9397	0.9391	0.9453	0.9476
0.96	NC	NC	NC	0.9446	0.9466
0.95	0.9186	0.9380	0.9384	0.9451	0.9468
0.94	NC	NC	NC	0.9445	0.9467
0.93	0.9130	0.9392	0.9352	0.9465	0.9460
0.92	NC	NC	NC	0.9458	0.9450
0.91	NC	NC	NC	0.9447	0.9452
0.90	0.9061	0.9384	NC	0.9449	0.9454
0.80	0.8774	0.9322	NC	0.9431	0.9390
0.70	0.8457	0.9190	NC	0.9339	0.9259
0.60	0.8095	0.8990	NC	0.9194	0.9058
0.40	0.7225	0.8280	NC	0.8575	0.8410
0.20	0.6131	0.7002	NC	0.7421	0.7271
0.10	0.5486	0.6178	NC	0.6662	0.6584

[†] External moderator is modeled at 0%. This is consistent with the results demonstrated in Table 6.4.1.

^{††} NC: Not Calculated

HOLTEC INTERNATIONAL COPYRIGHTED MATERIAL

Table 6.4.7

MAXIMUM k_{eff} VALUES FOR INTACT BWR FUEL ASSEMBLIES WITH A MAXIMUM PLANAR AVERAGE ENRICHMENT OF 3.7 wt% ^{235}U

Fuel Assembly Class	Maximum k_{eff}
6x6A	0.8287
6x6C	0.8436
7x7A	0.8399
7x7B	0.9109
8x8A	0.8102
8x8B	0.9131
8x8C	0.9115
8x8D	0.9125
8x8E	0.9049
8x8F	0.9233
9x9A	0.9111
9x9B	0.9134
9x9C	0.9103
9x9D	0.9096
9x9E	0.9237
9x9F	0.9237
9x9G	0.9005
10x10A	0.9158
10x10B	0.9156
10x10C	0.9152
10x10D	0.9182
10x10E	0.8970

HOLTEC INTERNATIONAL COPYRIGHTED MATERIAL

Table 6.4.8

MAXIMUM k_{eff} VALUES IN THE GENERIC BWR DAMAGED FUEL CONTAINER FOR A
 MAXIMUM INITIAL ENRICHMENT OF 4.0 wt% ^{235}U FOR DAMAGED FUEL AND 3.7
 wt% ^{235}U FOR INTACT FUEL

Model Configuration inside the DFC	Maximum k_{eff}
Intact Assemblies (4 assemblies analyzed)	0.9241
Assemblies with missing rods (7 configurations analyzed)	0.9240
Assemblies with distributed enrichment (4 configurations analyzed)	0.9245
Collapsed Assemblies (6 configurations analyzed)	0.9258
Regular Arrays of Bare Fuel Rods (31 configurations analyzed)	0.9328

HOLTEC INTERNATIONAL COPYRIGHTED MATERIAL

HI-STORM FSAR
 REPORT HI-2002444

6.4-26

Rev. 11

Table 6.4.9

MAXIMUM k_{eff} VALUES IN THE MPC-24E WITH THE GENERIC PWR DAMAGED FUEL CONTAINER FOR A MAXIMUM INITIAL ENRICHMENT OF 4.0 wt% ^{235}U AND NO SOLUBLE BORON.

Model Configuration inside the DFC	Maximum k_{eff}
Intact Assemblies (2 assemblies analyzed)	0.9340
Assemblies with missing rods (4 configurations analyzed)	0.9350
Collapsed Assemblies (6 configurations analyzed)	0.9360
Regular Arrays of Bare Fuel Rods (36 configurations analyzed)	0.9480

HOLTEC INTERNATIONAL COPYRIGHTED MATERIAL

HI-STORM FSAR
REPORT HI-2002444

6.4-27

Rev. 11

Table 6.4.10

MAXIMUM k_{eff} VALUES WITH FILLED AND VOIDED GUIDE TUBES
FOR THE MPC-32 AT 5.0 wt% ENRICHMENT

Fuel Class	Minimum Soluble Boron Content (ppm)	MPC-32 @ 5.0 %			
		Guide Tubes Filled,		Guide Tubes Voided,	
		1.0 g/cm ³	0.93 g/cm ³	1.0 g/cm ³	0.93 g/cm ³
14x14A	1900	0.8984	0.9000	0.8953	0.8943
14x14B	1900	0.9210	0.9214	0.9164	0.9118
14x14C	1900	0.9371	0.9376	0.9480	0.9421
14x14D	1900	0.9050	0.9027	0.8947	0.8904
14x14E	1900	0.7415	0.7301	n/a	n/a
15x15A	2500	0.9210	0.9223	0.9230	0.9210
15x15B	2500	0.9402	0.9420	0.9429	0.9421
15x15C	2500	0.9258	0.9292	0.9307	0.9293
15x15D	2600	0.9426	0.9419	0.9466	0.9440
15x15E	2600	0.9394	0.9415	0.9434	0.9442
15x15F	2600	0.9445	0.9465	0.9483	0.9460
15x15G	2500	0.9228	0.9244	0.9251	0.9243
15X15H	2600	0.9271	0.9301	0.9317	0.9333
15x15I [†]	2500	0.9402	0.9363	-	-
16X16A	2000	0.9377	0.9375	0.9429	0.9389
17x17A	2600	0.9105	0.9145	0.9160	0.9161
17x17B	2600	0.9345	0.9358	0.9371	0.9356
17X17C	2600	0.9417	0.9431	0.9437	0.9430

[†] This array/class has solid guide rods that cannot be filled or voided.

HOLTEC INTERNATIONAL COPYRIGHTED MATERIAL

HI-STORM FSAR
REPORT HI-2002444

6.4-28

Rev. 11

Table 6.4.11

MAXIMUM k_{eff} VALUES WITH FILLED AND VOIDED GUIDE TUBES
FOR THE MPC-32 AT 4.1 wt% ENRICHMENT

Fuel Class	Minimum Soluble Boron Content (ppm)	MPC-32 @ 4.1 %			
		Guide Tubes Filled		Guide Tubes Voided	
		1.0 g/cm ³	0.93 g/cm ³	1.0 g/cm ³	0.93 g/cm ³
14x14A	1300	0.9041	0.9029	0.8954	0.8939
14x14B	1300	0.9257	0.9205	0.9128	0.9074
14x14C	1300	0.9402	0.9384	0.9423	0.9365
14x14D	1300	0.8970	0.8943	0.8836	0.8788
14x14E	1300	0.7340	0.7204	n/a	n/a
15x15A	1800	0.9199	0.9206	0.9193	0.9134
15x15B	1800	0.9397	0.9387	0.9385	0.9347
15x15C	1800	0.9266	0.9250	0.9264	0.9236
15x15D	1900	0.9375	0.9384	0.9380	0.9329
15x15E	1900	0.9348	0.9340	0.9365	0.9336
15x15F	1900	0.9411	0.9392	0.9400	0.9352
15x15G	1800	0.9147	0.9128	0.9125	0.9062
15X15H	1900	0.9267	0.9274	0.9276	0.9268
15x15I [‡]	1800	0.9340	0.9316	-	-
16X16A	1400	0.9367	0.9347	0.9375	0.9308
17x17A	1900	0.9105	0.9111	0.9106	0.9091
17x17B	1900	0.9309	0.9307	0.9297	0.9243
17X17C	1900	0.9355	0.9347	0.9350	0.9308

[‡] This array/class has solid guide rods that cannot be filled or voided.

HOLTEC INTERNATIONAL COPYRIGHTED MATERIAL

HI-STORM FSAR
REPORT HI-2002444

6.4-29

Rev. 11

Table 6.4.12

MAXIMUM k_{eff} VALUES IN THE MPC-24E WITH THE GENERIC PWR DAMAGED FUEL CONTAINER FOR A MAXIMUM INITIAL ENRICHMENT OF 5.0 wt% ^{235}U AND 600 PPM SOLUBLE BORON.

Water Density inside the DFC	Bare Fuel Pellet Diameter	Maximum k_{eff}
1.00	minimum	0.9185
1.00	typical	0.9181
1.00	maximum	0.9171
0.95	typical	0.9145
0.90	typical	0.9125
0.60	typical	0.9063
0.10	typical	0.9025
0.02	typical	0.9025

HOLTEC INTERNATIONAL COPYRIGHTED MATERIAL

HI-STORM FSAR
REPORT HI-2002444

6.4-30

Rev. 11

Table 6.4.13

MAXIMUM k_{eff} VALUES IN THE MPC-32 WITH THE GENERIC PWR DAMAGED FUEL CONTAINER FOR A MAXIMUM INITIAL ENRICHMENT OF 5.0 wt% ^{235}U , 2900 PPM SOLUBLE BORON AND THE 15x15F ASSEMBLY CLASS AS INTACT ASSEMBLY.

Water Density inside the DFC	Bare Fuel Pellet Diameter	Maximum k_{eff}
1.00	minimum	0.9374
1.00	typical	0.9372
1.00	maximum	0.9373
0.95	typical	0.9369
0.90	typical	0.9365
0.60	typical	0.9308
0.10	typical	0.9295
0.02	typical	0.9283

HOLTEC INTERNATIONAL COPYRIGHTED MATERIAL

HI-STORM FSAR
REPORT HI-2002444

6.4-31

Rev. 11

Table 6.4.14

BOUNDING MAXIMUM k_{eff} VALUES FOR THE MPC-32
WITH UP TO 8 DFCs UNDER VARIOUS MODERATION CONDITIONS.

Fuel Assembly Class of Intact Fuel	Initial Enrichment (wt% ^{235}U)	Minimum Soluble Boron Content (ppm)	Maximum k_{eff}			
			Filled Guide Tubes		Voided Guide Tubes	
			1.0 g/cm ³	0.93 g/cm ³	1.0 g/cm ³	0.93 g/cm ³
14x14A through 14x14E	4.1	1500	0.9277	0.9283	0.9336	0.9298
	5.0	2300	0.9139	0.9180	0.9269	0.9262
15x15A, B, C, G, I	4.1	1900	0.9345	0.9350	0.9350	0.9326
	5.0	2700	0.9307	0.9346	0.9347	0.9365
15x15D, E, F, H	4.1	2100	0.9322	0.9336	0.9340	0.9329
	5.0	2900	0.9342	0.9375	0.9385	0.9397
16x16A	4.1	1500	0.9330	0.9332	0.9348	0.9333
	5.0	2300	0.9212	0.9246	0.9283	0.9299
17x17A, B, C	4.1	2100	0.9284	0.9290	0.9294	0.9285
	5.0	2900	0.9308	0.9338	0.9355	0.9367

HOLTEC INTERNATIONAL COPYRIGHTED MATERIAL

Table 6.4.15

COMPARISON OF MAXIMUM k_{eff} VALUES FOR DIFFERENT FIXED NEUTRON ABSORBER MATERIALS

Case	Maximum k_{eff}		Reactivity Difference
	BORAL	METAMIC	
MPC-68, Intact Assemblies	0.9457	0.9452	-0.0005
MPC-68, with 16 DFCs	0.9328	0.9315	-0.0013
MPC-68F with 68 DFCs	0.8021	0.8019	-0.0002
MPC-24, 0ppm	0.9478	0.9491	+0.0013
MPC-24, 400ppm	0.9447	0.9457	+0.0010
MPC-24E, Intact Assemblies, 0ppm	0.9468	0.9494	+0.0026
MPC-24E, Intact Assemblies, 300ppm	0.9399	0.9410	+0.0011
MPC-24E, with 4 DFCs, 0ppm	0.9480	0.9471	-0.0009
MPC-32, Intact Assemblies, 1900ppm	0.9411	0.9397	-0.0014
MPC-32, Intact Assemblies, 2600ppm	0.9483	0.9471	-0.0012
Average Difference			+0.0001

HOLTEC INTERNATIONAL COPYRIGHTED MATERIAL

HI-STORM FSAR
REPORT HI-2002444

6.4-33

Rev. 11

DELETED

FIGURE 6.4.1

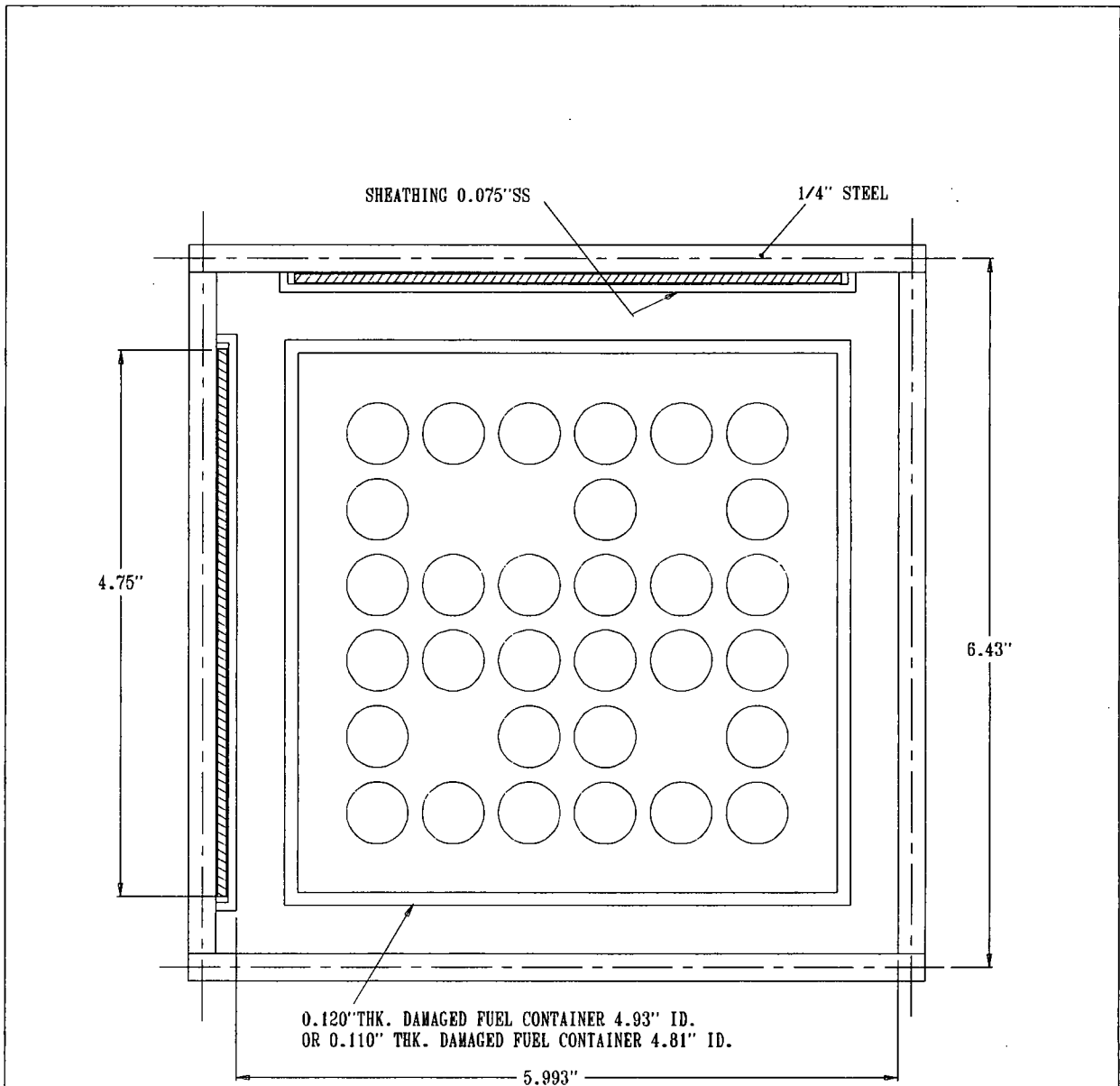


FIGURE 6.4.2; FAILED FUEL CALCULATION MODEL (PLANAR CROSS-SECTION)
 WITH 6X6 ARRAY WITH 4 MISSING RODS IN THE MPC-68 BASKET
 (SEE CHAPTER 1 FOR TRUE BASKET DIMENSIONS)

NOTE: THESE DIMENSIONS WERE CONSERVATIVELY USED FOR CRITICALITY ANALYSES.

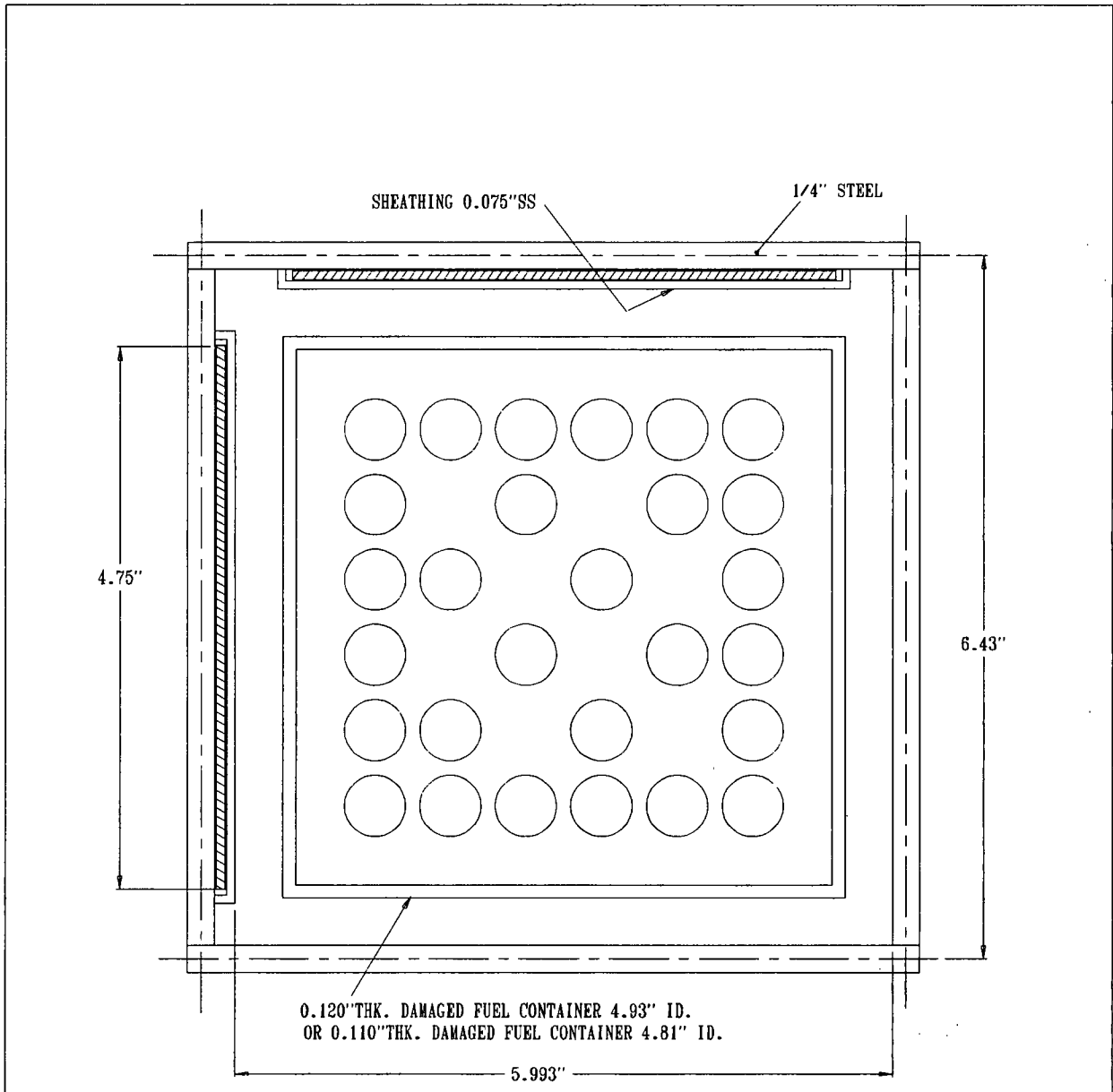


FIGURE 6.4.3; FAILED FUEL CALCULATION MODEL (PLANAR CROSS-SECTION) WITH 6X6 ARRAY WITH 8 MISSING RODS IN THE MPC-68 BASKET (SEE CHAPTER 1 FOR TRUE BASKET DIMENSIONS)

NOTE: THESE DIMENSIONS WERE CONSERVATIVELY USED FOR CRITICALITY ANALYSES.

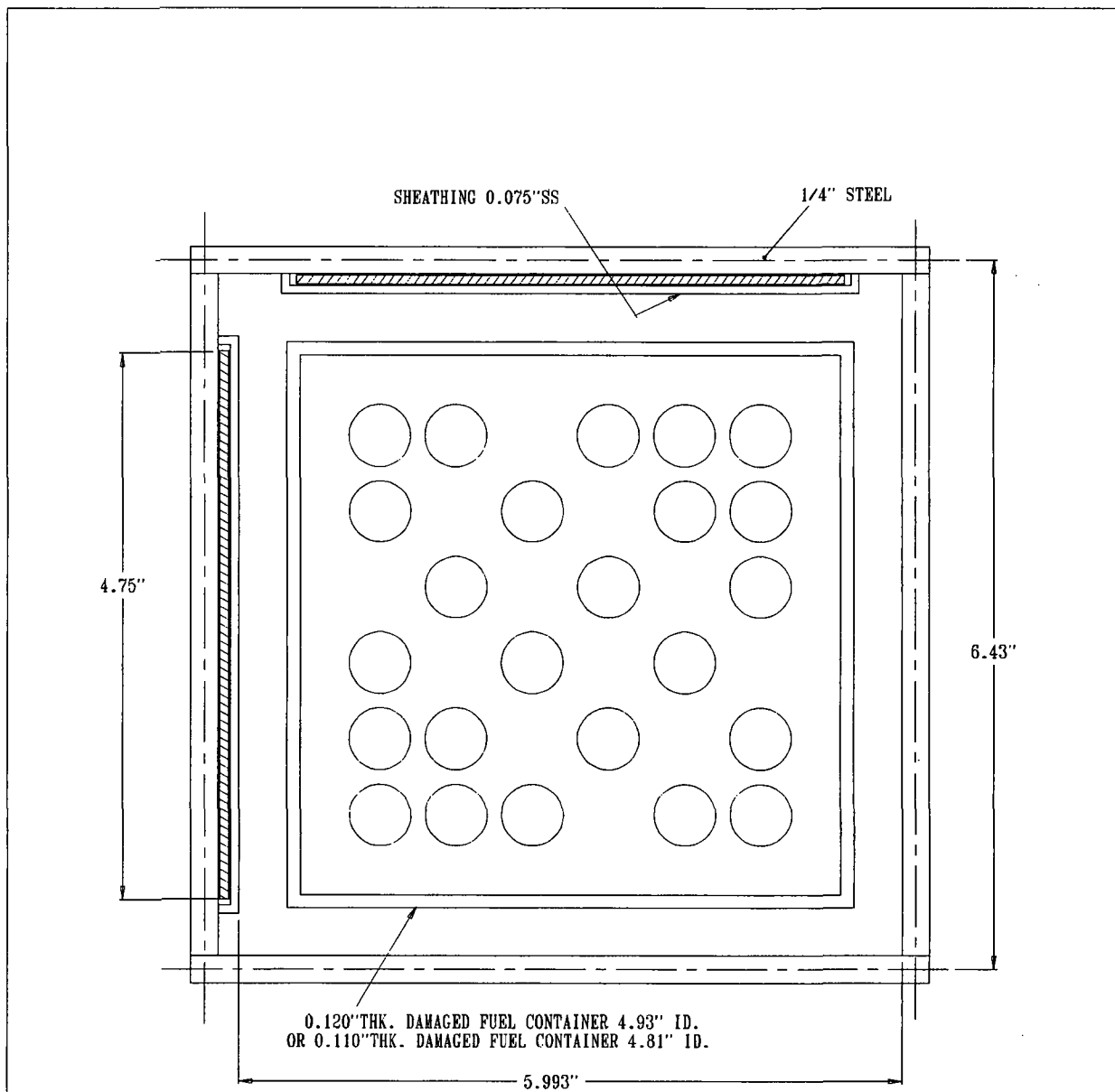
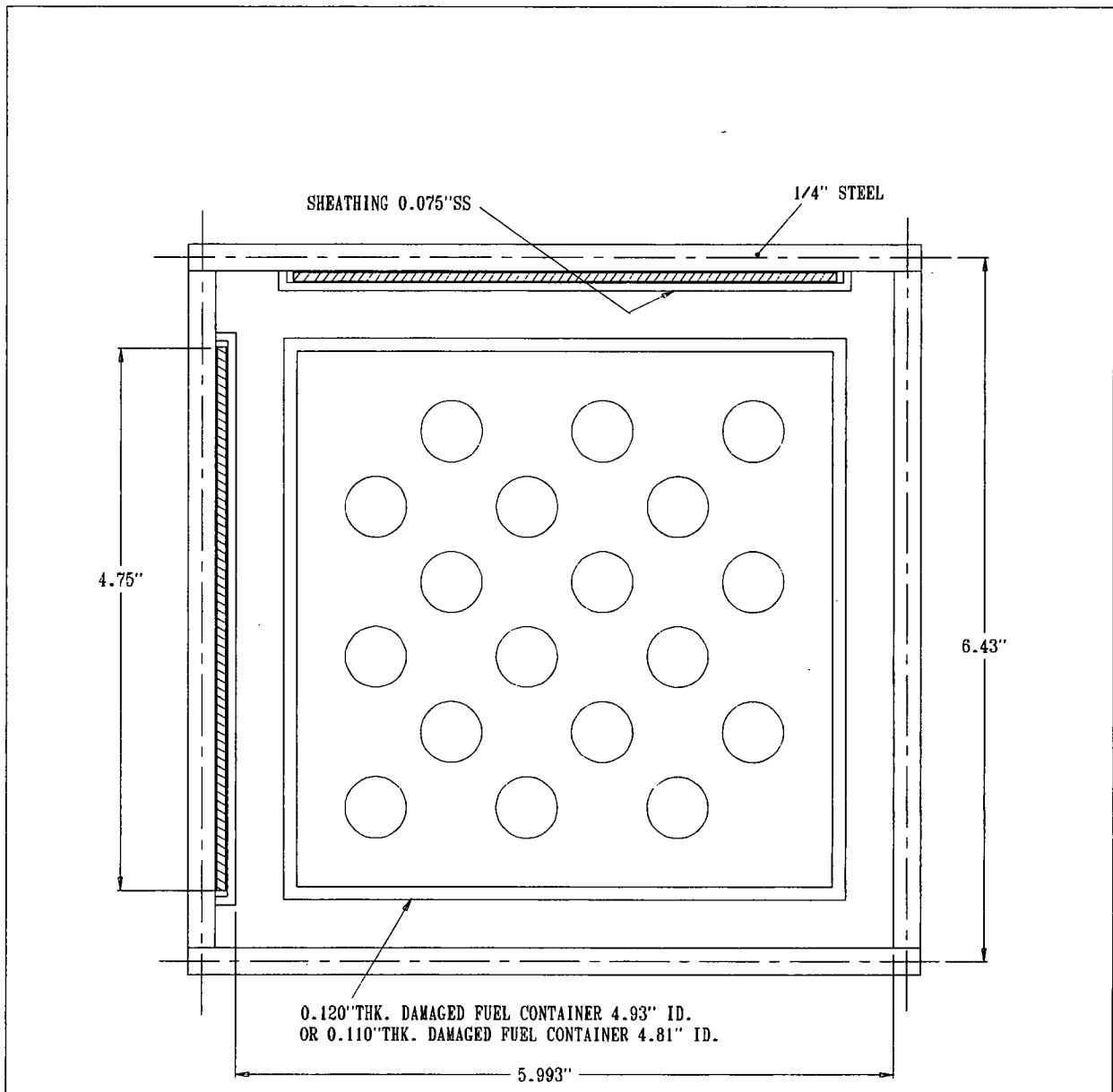


FIGURE 6.4.4; FAILED FUEL CALCULATION MODEL (PLANAR CROSS-SECTION)
WITH 6X6 ARRAY WITH 12 MISSING RODS IN THE MPC-68 BASKET
(SEE CHAPTER 1 FOR TRUE BASKET DIMENSIONS)

NOTE: THESE DIMENSIONS WERE CONSERVATIVELY USED FOR CRITICALITY ANALYSES.



**FIGURE 6.4.5; FAILED FUEL CALCULATION MODEL (PLANAR CROSS-SECTION)
WITH 6X6 ARRAY WITH 18 MISSING RODS IN THE MPC-68 BASKET
(SEE CHAPTER 1 FOR TRUE BASKET DIMENSIONS)**

NOTE: THESE DIMENSIONS WERE CONSERVATIVELY USED FOR CRITICALITY ANALYSES.

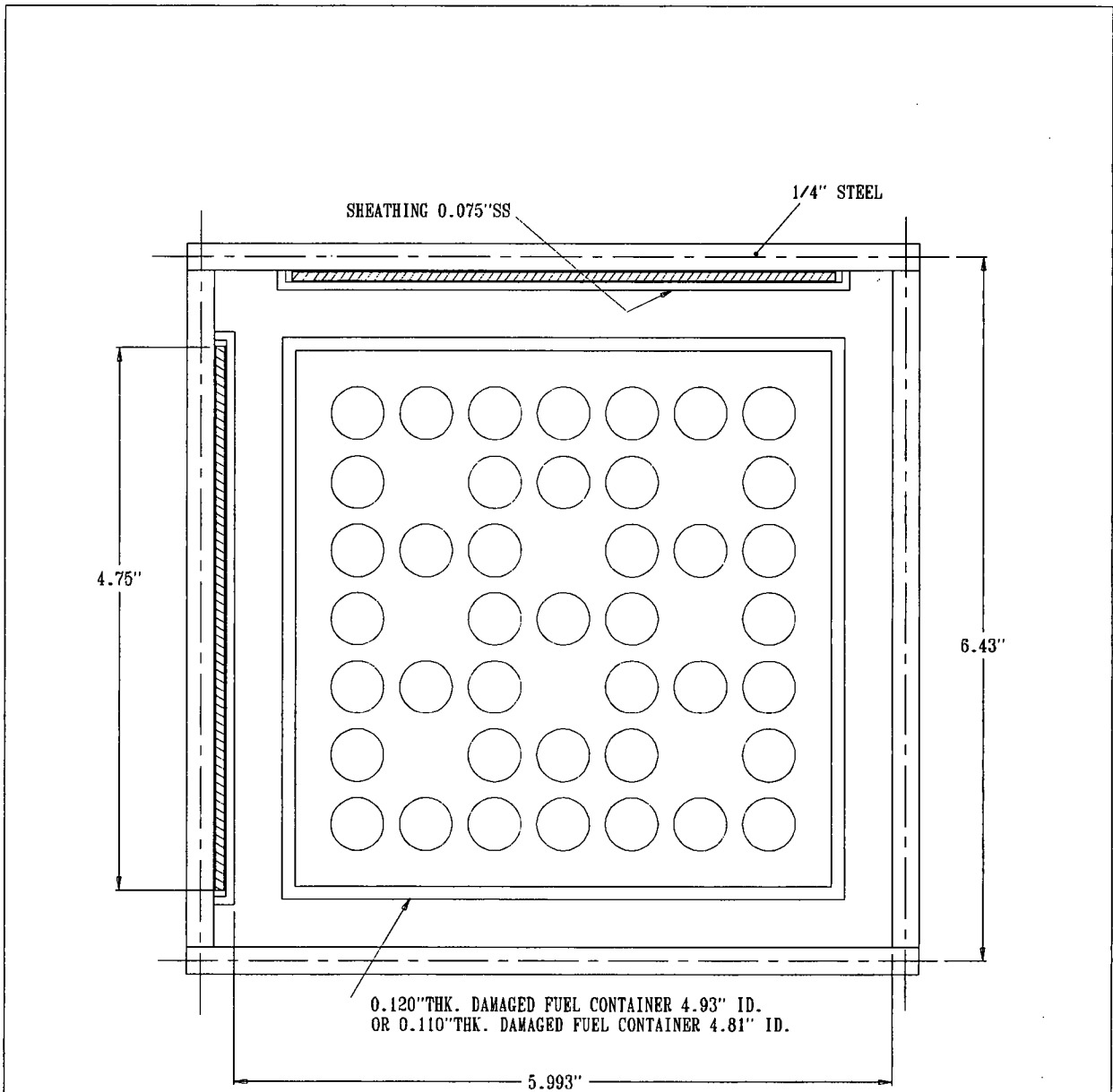


FIGURE 6.4.6; FAILED FUEL CALCULATION MODEL (PLANAR CROSS-SECTION) WITH 7X7 ARRAY WITH 8 MISSING RODS IN THE MPC-68 BASKET (SEE CHAPTER 1 FOR TRUE BASKET DIMENSIONS)

NOTE: THESE DIMENSIONS WERE CONSERVATIVELY USED FOR CRITICALITY ANALYSES.

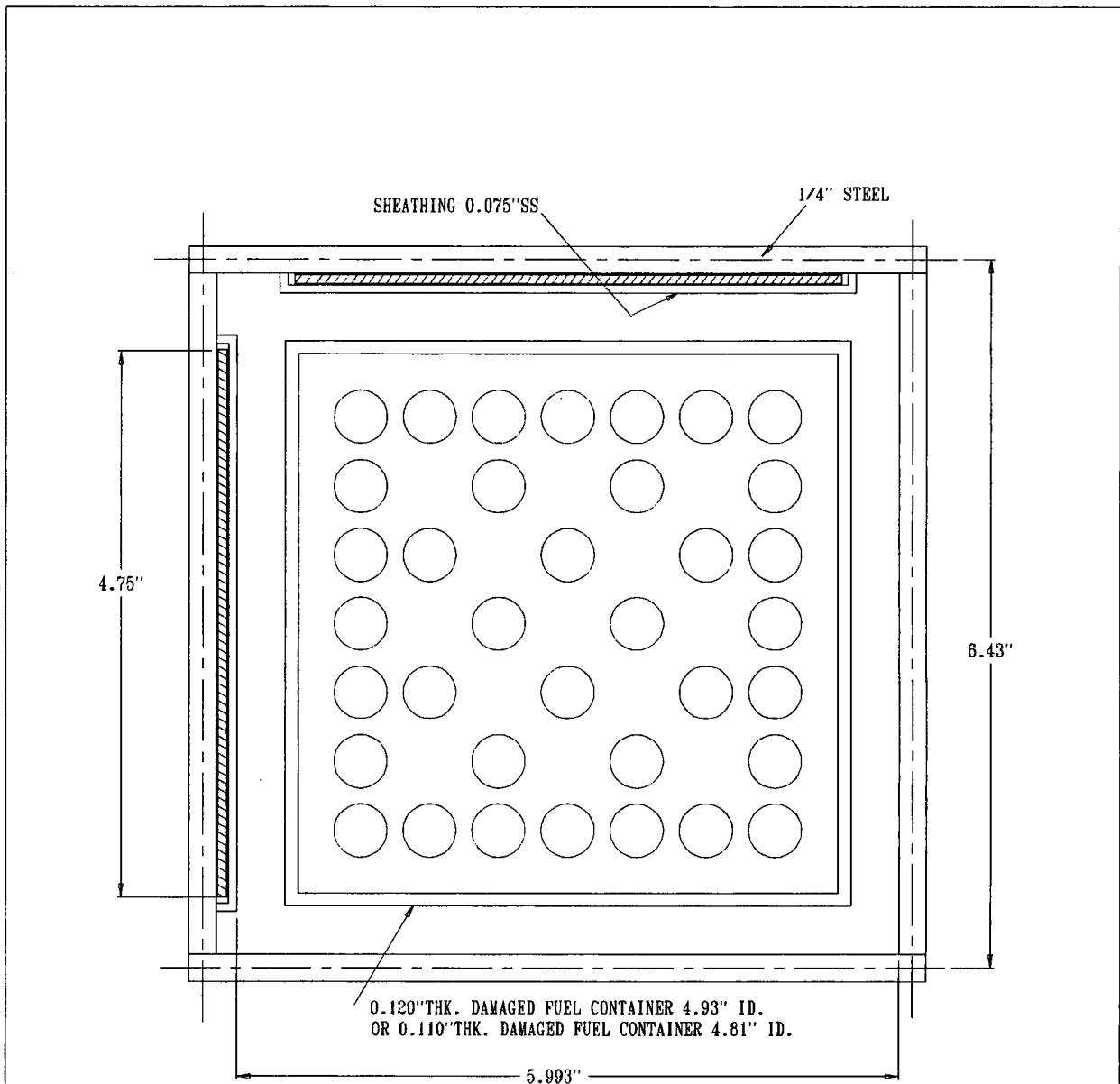


FIGURE 6.4.7; FAILED FUEL CALCULATION MODEL (PLANAR CROSS-SECTION)
WITH 7X7 ARRAY WITH 13 MISSING RODS IN THE MPC-68 BASKET
(SEE CHAPTER 1 FOR TRUE BASKET DIMENSIONS)

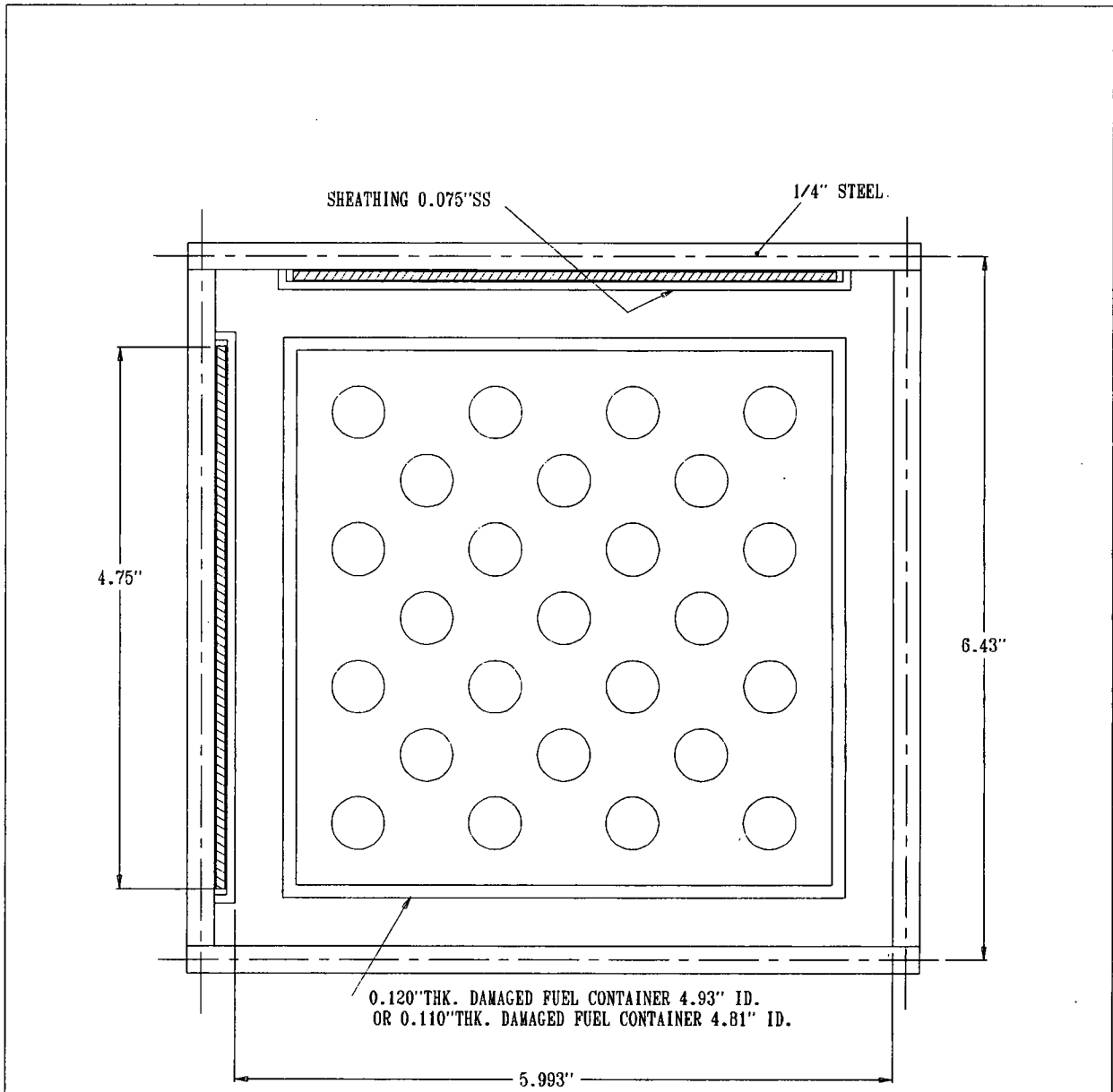


FIGURE 6.4.8; FAILED FUEL CALCULATION MODEL (PLANAR CROSS-SECTION)
 WITH 7X7 ARRAY WITH 24 MISSING RODS IN THE MPC-68 BASKET
 (SEE CHAPTER 1 FOR TRUE BASKET DIMENSIONS)

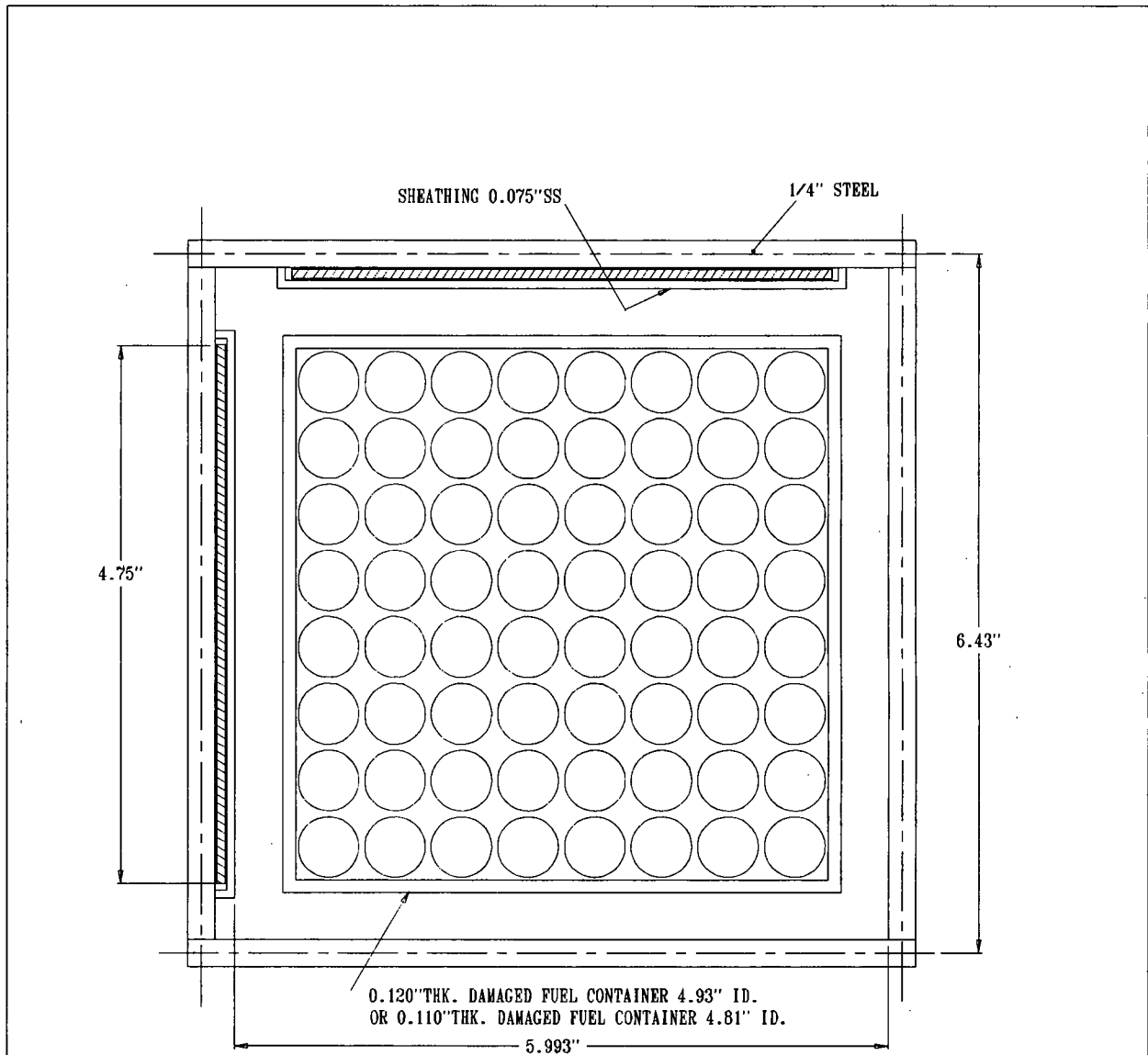


FIGURE 6.4.9; FAILED FUEL CALCULATION MODEL (PLANAR CROSS-SECTION) WITH DAMAGED FUEL COLLAPSED INTO 8X8 ARRAY IN THE MPC-68 BASKET (SEE CHAPTER 1 FOR TRUE BASKET DIMENSIONS)

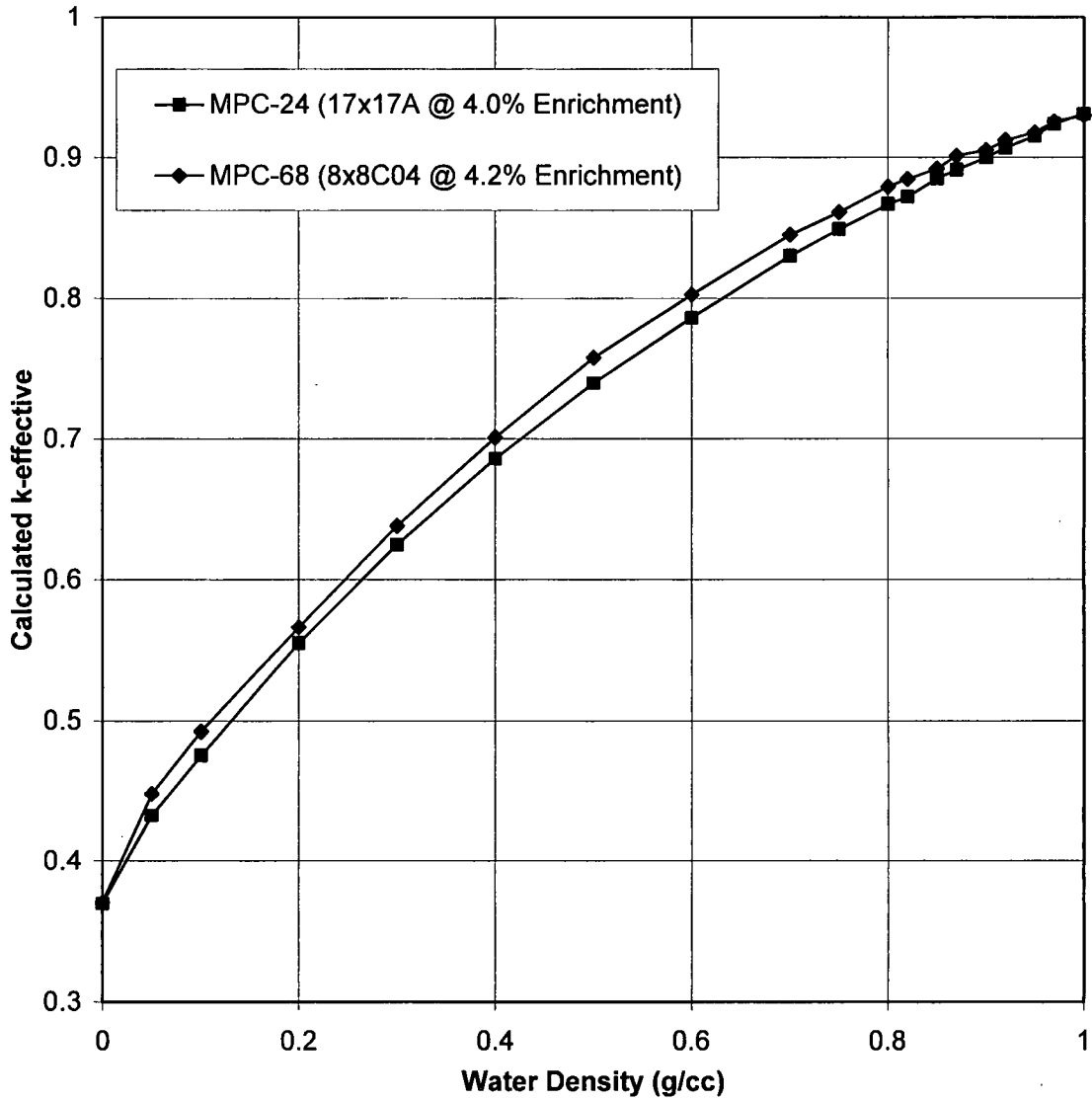


FIGURE 6.4.10; CALCULATED K-EFFECTIVE AS A FUNCTION OF INTERNAL MODERATOR DENSITY

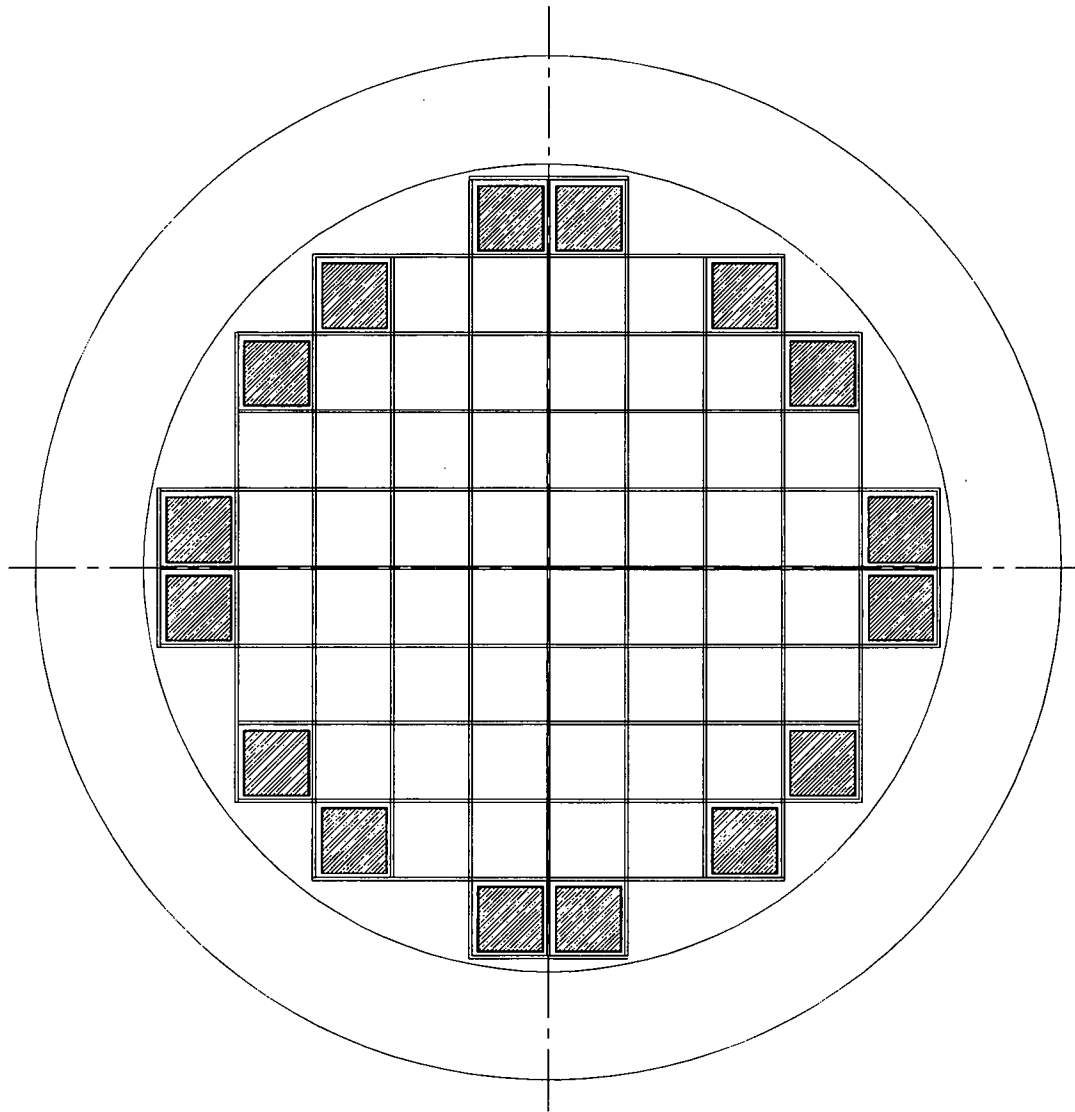


FIGURE 6.4.11; LOCATIONS OF THE DAMAGED FUEL CONTAINER
IN THE MPC-68 AND MPC-68FF

REPORT HI-2002444

REVISION. 1

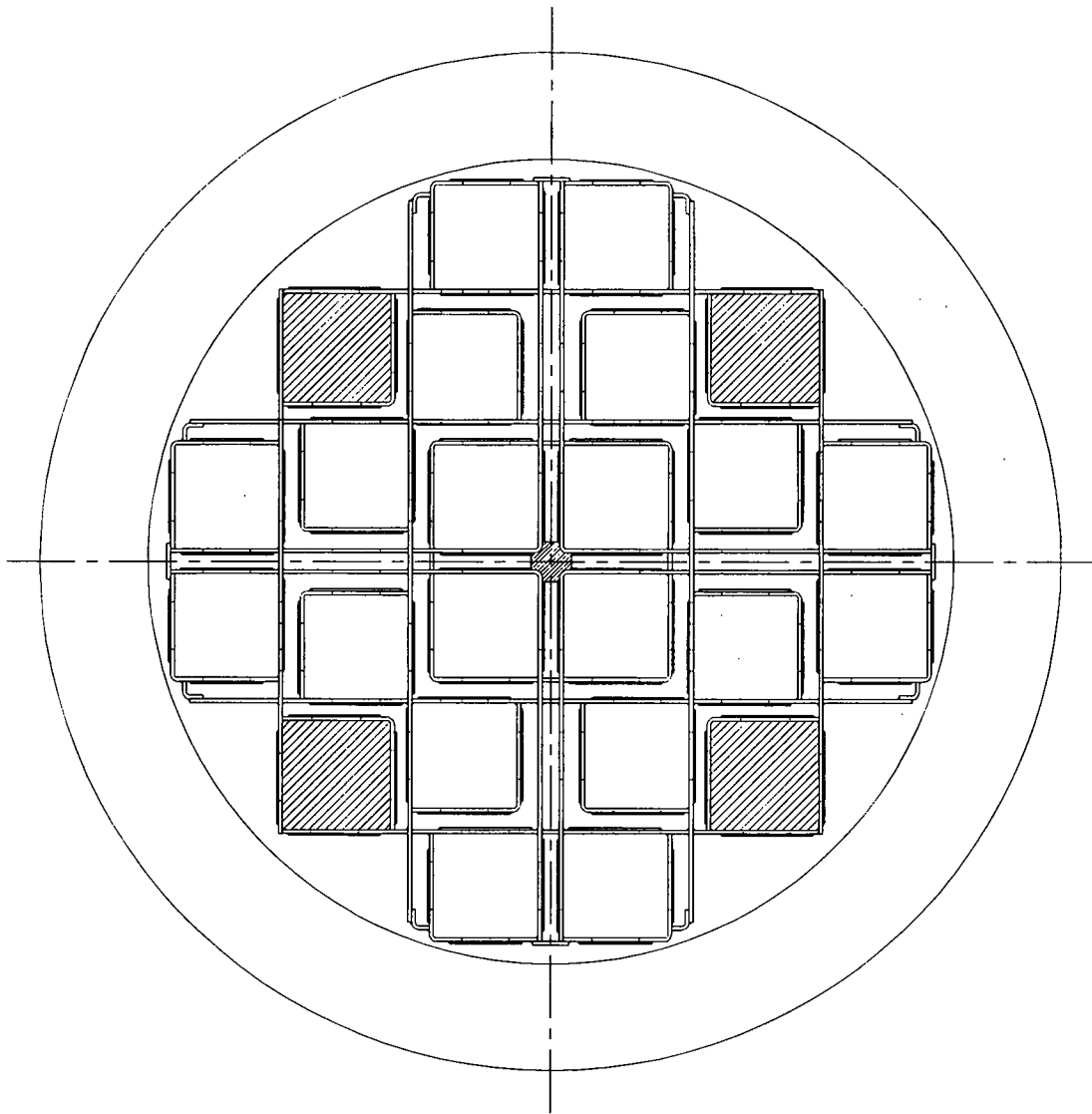


FIGURE 6.4.12; LOCATIONS OF THE DAMAGED FUEL CONTAINERS
IN THE MPC 24E

REPORT HI-2002444

REVISION. 1

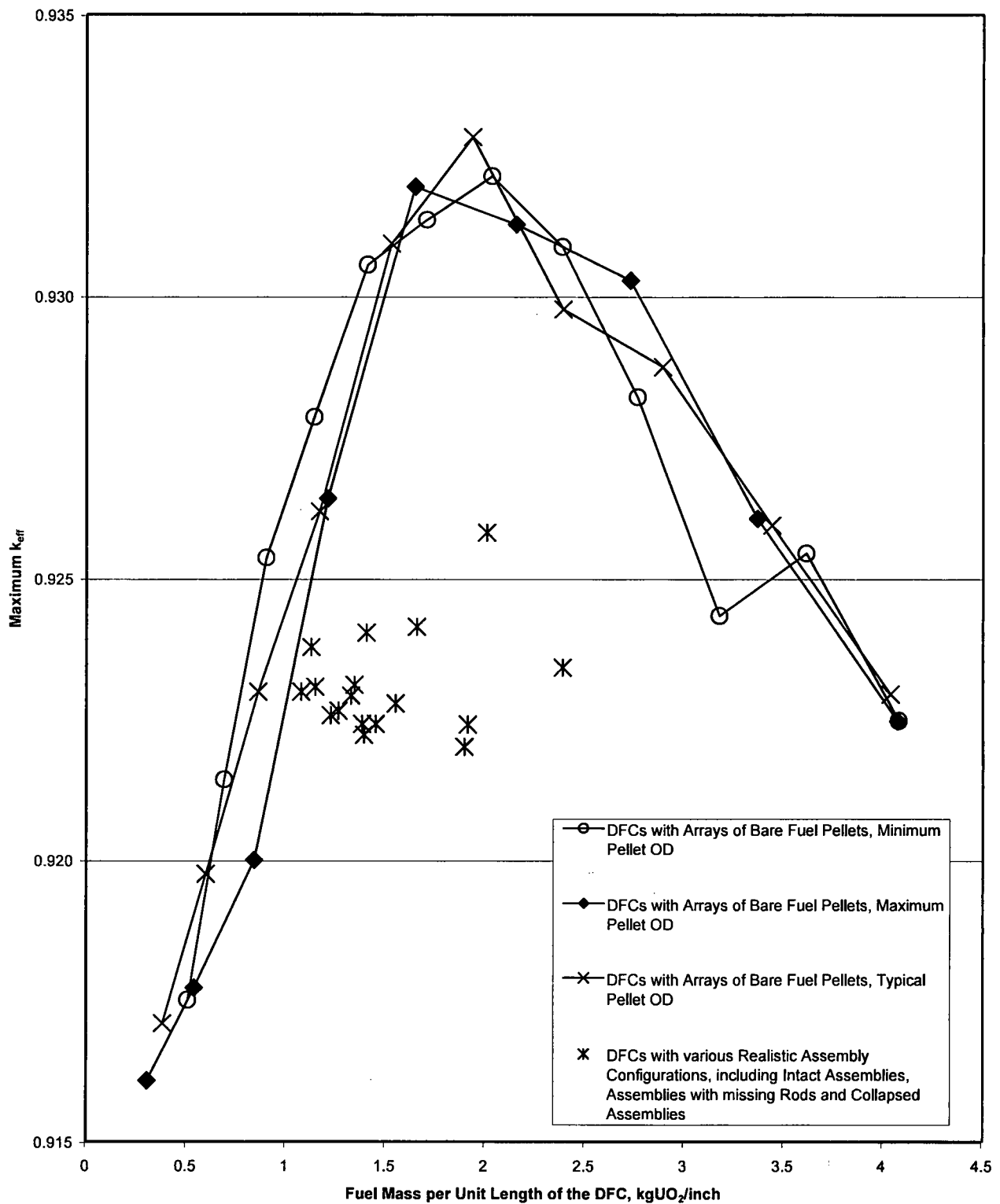


Figure 6.4.13: Maximum k_{eff} for the MPC-68 with Generic BWR Damaged Fuel Container, Initial Enrichment of 4.0 wt% for Damaged and 3.7 wt% for Intact Fuel.

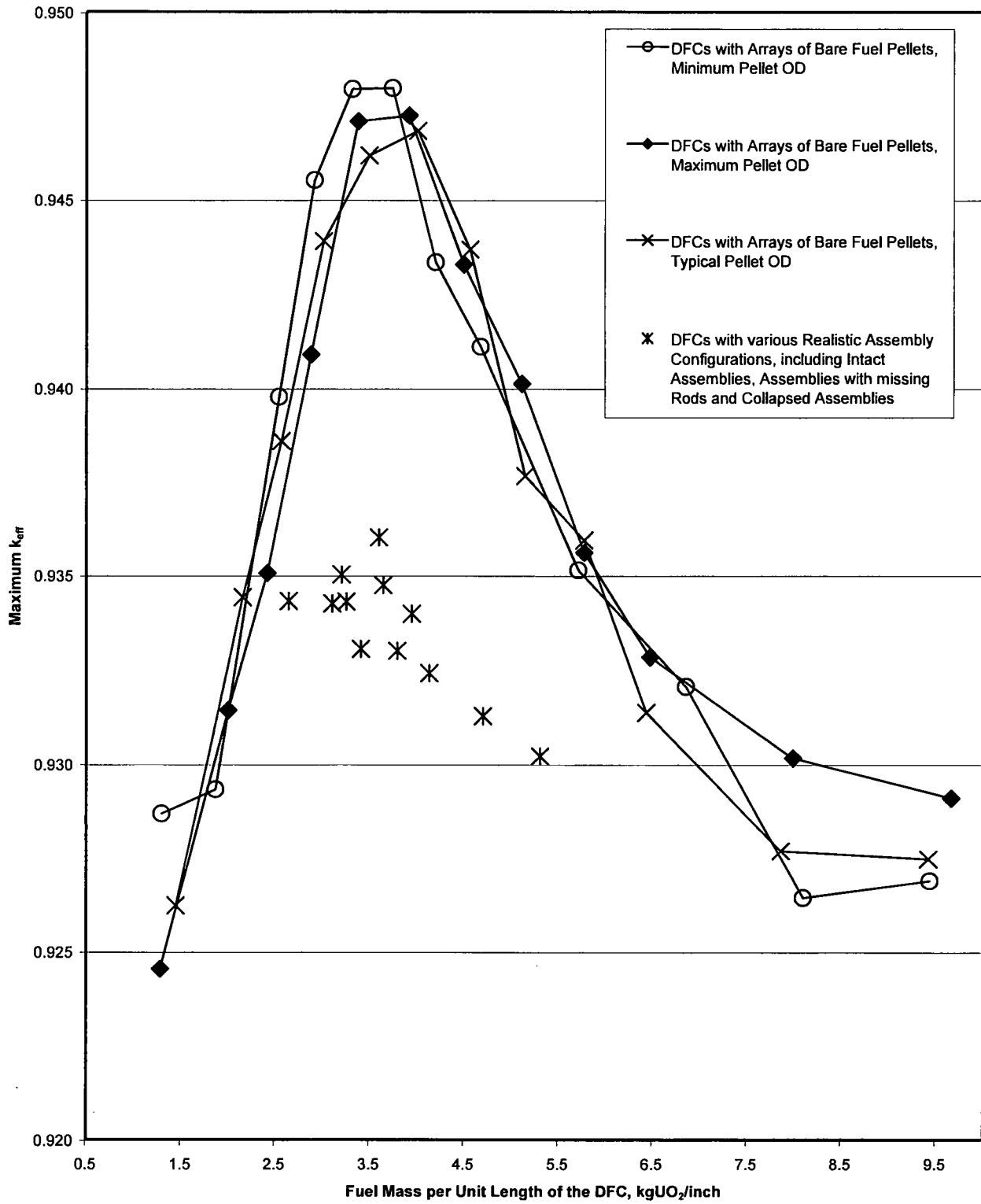


Figure 6.4.14: Maximum keff for the MPC-24E with Generic PWR Damaged Fuel Container; Initial Enrichment of 4.0 wt% for Damaged and Intact Fuel.

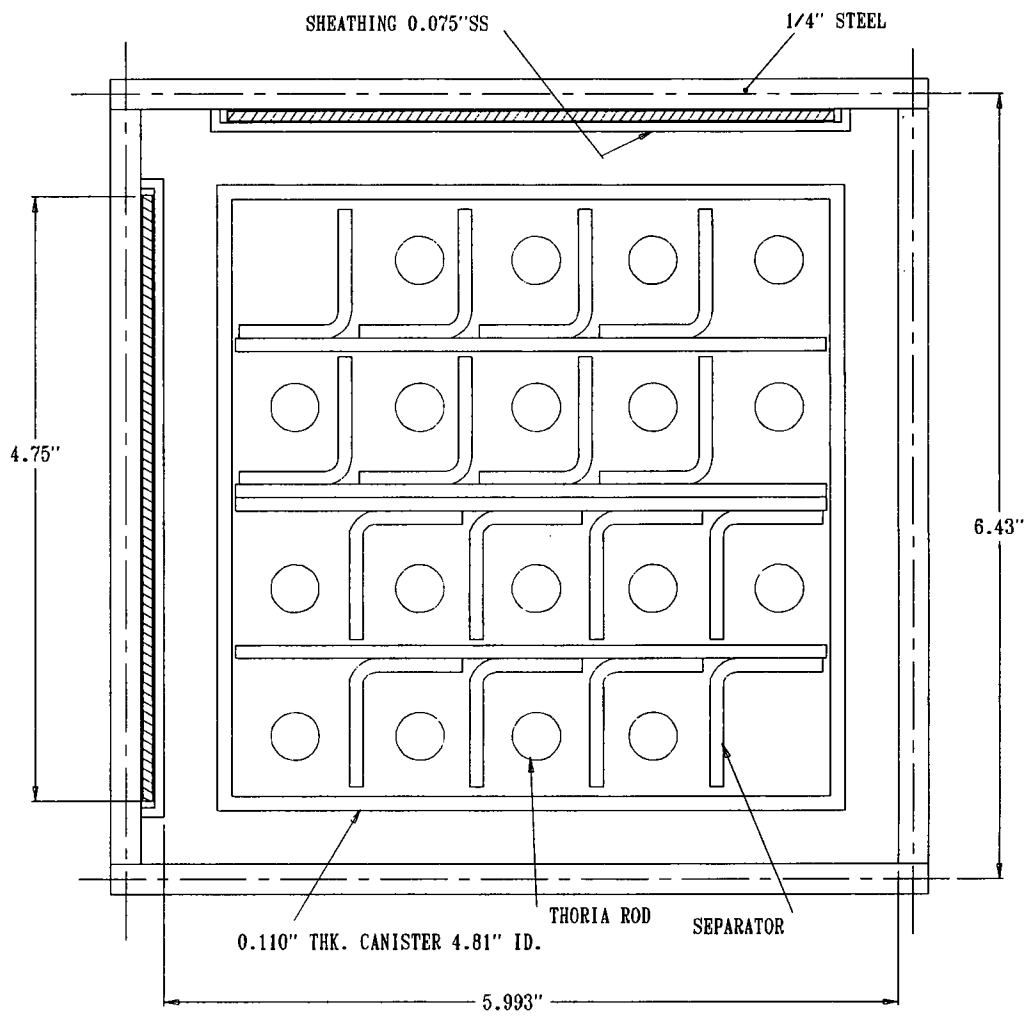
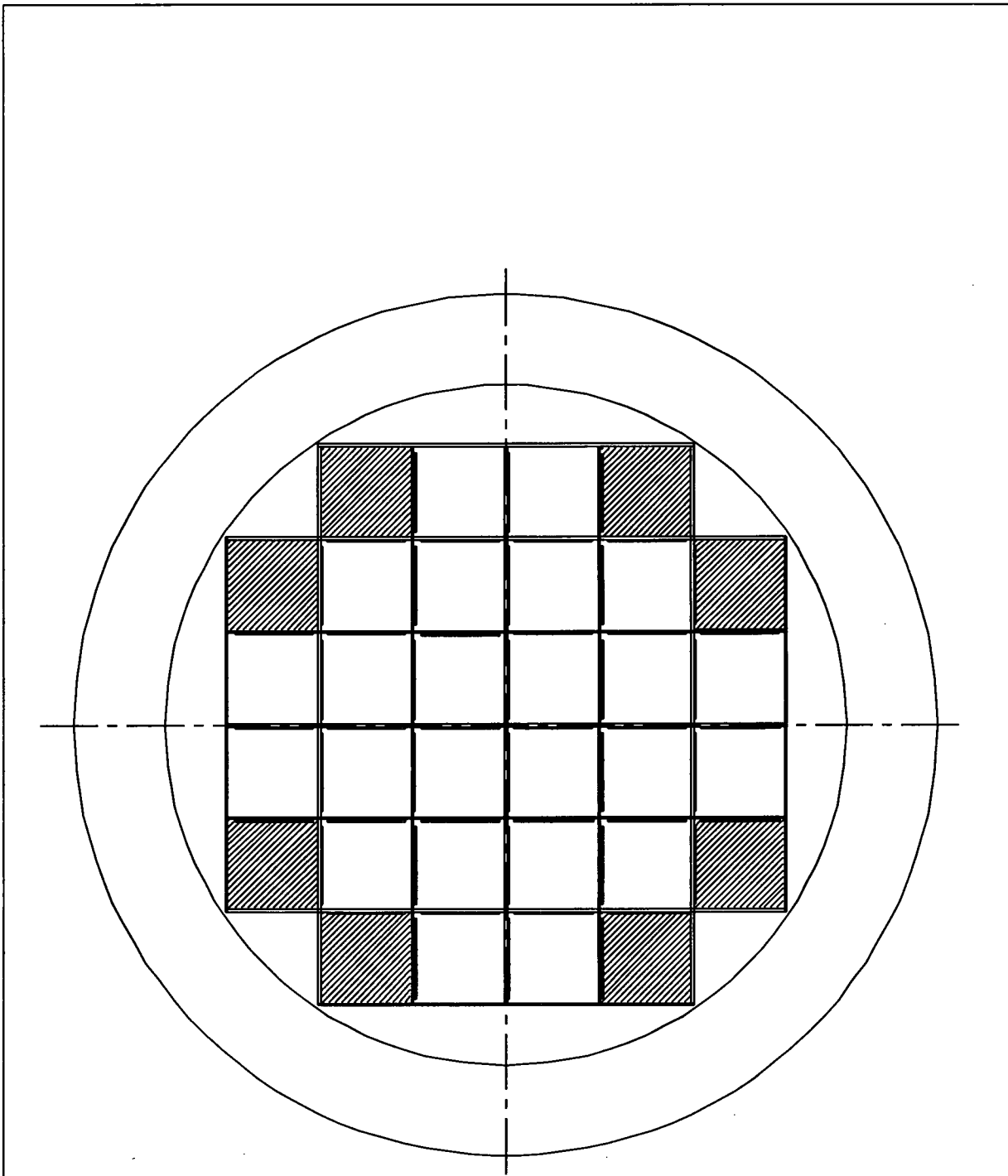


FIGURE 6.4.15; THORIA ROD CANISTER (PLANAR CROSS-SECTION) WITH 18 THORIA RODS IN THE MPC-68 BASKET (SEE CHAPTER 1 FOR TRUE BASKET DIMENSIONS)



**FIGURE 6.4.16; LOCATIONS OF THE DAMAGED FUEL CONTAINERS
IN THE MPC-32.**

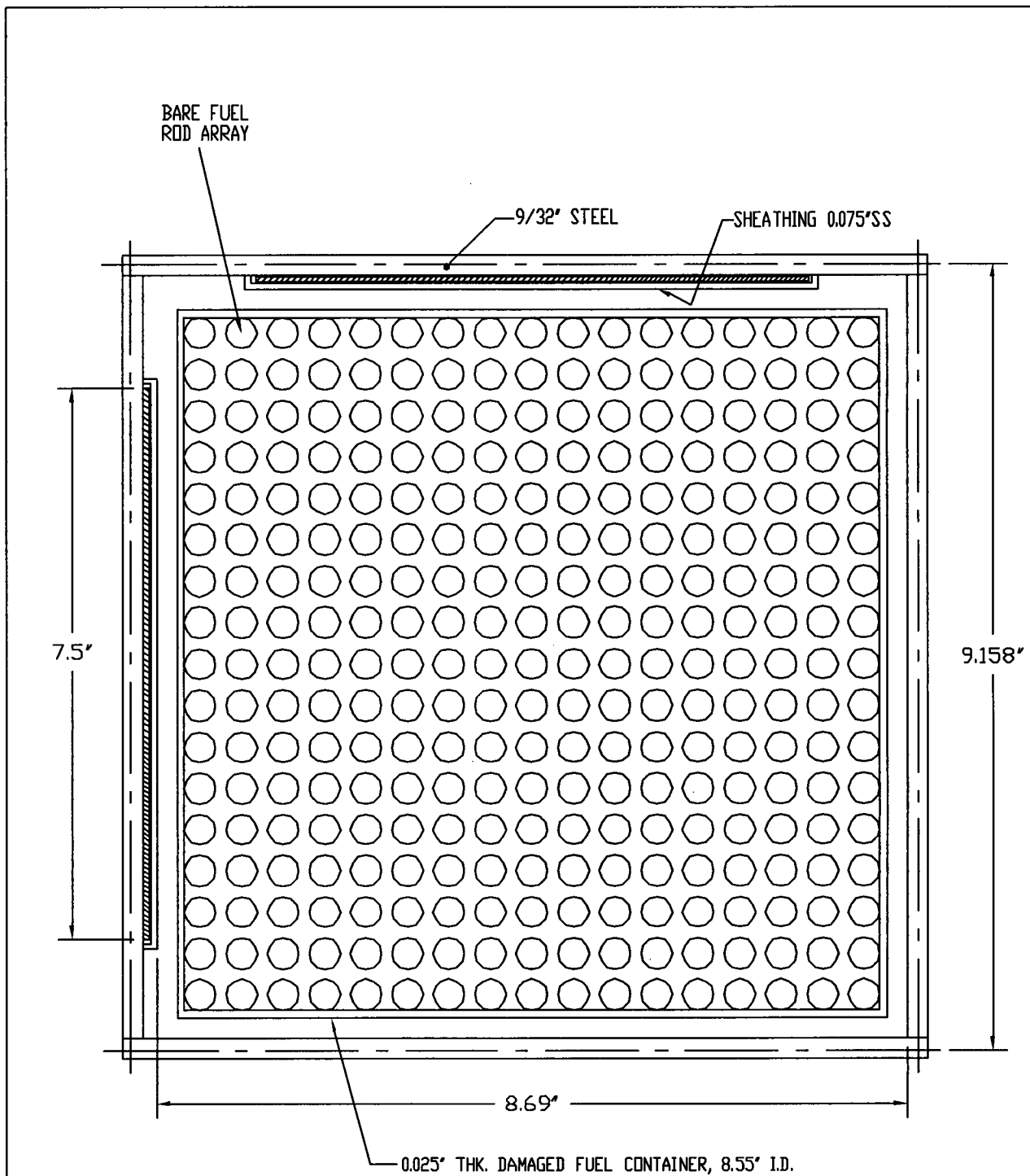


FIGURE 6.4.17; DAMAGED FUEL/FUEL DERIS CALCULATION MODEL (PLANAR CROSS-SECTION) WITH BARE FUEL RODS IN THE MPC-32 BASKET
 (SEE CHAPTER 1 FOR TRUE BASKET DIMENSIONS)

Benchmark calculations have been made on selected critical experiments, chosen, insofar as possible, to bound the range of variables in the cask designs. The most important parameters are (1) the enrichment, (2) the water-gap size (MPC-24) or cell spacing (MPC-68), and (3) the ^{10}B loading of the neutron absorber panels. Other parameters, within the normal range of cask and fuel designs, have a smaller effect, but are also included. No significant trends were evident in the benchmark calculations or the derived bias. Detailed benchmark calculations are presented in Appendix 6.A.

The benchmark calculations were performed with the same computer codes and cross-section data, described in Section 6.4, that were used to calculate the k_{eff} values for the cask. Further, all calculations were performed on the same computer hardware, specifically, personal computers using the pentium processor.

HOLTEC INTERNATIONAL COPYRIGHTED MATERIAL

HI-STORM FSAR
REPORT HI-2002444

6.5-1

Rev. 0

This chapter documents the criticality evaluation of the HI-STORM 100 System for the storage of spent nuclear fuel. This evaluation demonstrates that the HI-STORM 100 System is in full compliance with the criticality requirements of 10CFR72 and NUREG-1536.

Structures, systems, and components important to criticality safety, as well as the limiting fuel characteristics, are described in sufficient detail in this chapter to enable an evaluation of their effectiveness.

The HI-STORM 100 System is designed to be subcritical under all credible conditions. The criticality design is based on favorable geometry and fixed neutron poisons (Boral). An appraisal of the fixed neutron poisons has shown that they will remain effective for a storage period greater than 20 years, and there is no credible way to lose it, therefore there is no need to provide a positive means to verify their continued efficacy as required by 10CFR72.124(b).

The criticality evaluation has demonstrated that the cask will enable the storage of spent fuel for a minimum of 20 years with an adequate margin of safety. Further, the evaluation has demonstrated that the design basis accidents have no adverse effect on the design parameters important to criticality safety, and therefore, the HI-STORM 100 System is in full compliance with the double contingency requirements of 10CFR72.124. Therefore, it is concluded that the criticality design features for the HI-STORM 100 System are in compliance with 10 CFR Part 72 and that the applicable design and acceptance criteria have been satisfied. The criticality evaluation provides reasonable assurance that the HI-STORM 100 System will allow safe storage of spent fuel.

HOLTEC INTERNATIONAL COPYRIGHTED MATERIAL

REFERENCES

- [6.1.1] NUREG-1536, Standard Review Plan for Dry Cask Storage Systems, USNRC, Washington, D.C., January 1997.
- [6.1.2] 10CFR72.124, "Criteria For Nuclear Criticality Safety."
- [6.1.3] USNRC Standard Review Plan, NUREG-0800, Section 9.1.2, Spent Fuel Storage, Rev. 2 - July 1981.
- [6.1.4] J.F. Briesmeister, Ed., "MCNP - A General Monte Carlo N-Particle Transport Code, Version 4A," Los Alamos National Laboratory, LA-12625-M (1993).
- [6.1.5] L.M. Petrie and N.F. Landers, "KENOVa - An Improved Monte Carlo Criticality Program with Supergrouping," Volume 2, Section F11 from "SCALE: A Modular System for Performing Standardized Computer Analysis for Licensing Evaluation," NUREG/CR-0200, Rev. 4, January 1990.
- [6.1.6] N.M. Greene, L.M. Petrie and R.M. Westfall, "NITAWL-II: Scale System Module For Performing Resonance Shielding and Working Library Production," Volume 1, Section F1 from "SCALE: A Modular System for Performing Standardized Computer Analysis for Licensing Evaluation," NUREG/CR-0200, Rev. 4, January 1990.
- [6.1.7] J.R. Knight, "SUPERDAN: Computer Programs for Calculating the Dancoff Factor of Spheres, Cylinders, and Slabs," Oak Ridge National Laboratory, ORNL/NUREG/CSD/TM-2, March 1978, with correction published in "Proceedings of Seminar on SCALE-4," Saclay, France, 1991.
- [6.1.8] M.G. Natrella, Experimental Statistics, National Bureau of Standards, Handbook 91, August 1963.
- [6.1.9] A. Ahlin, M. Edenius, and H. Haggblom, "CASMO - A Fuel Assembly Burnup Program," AE-RF-76-4158, Studsvik report.

HOLTEC INTERNATIONAL COPYRIGHTED MATERIAL

HI-STORM FSAR
REPORT HI-2002444

6.7-1

Rev. 1

- [6.1.10] A. Ahlin and M. Edenius, "CASMO - A Fast Transport Theory Depletion Code for LWR Analysis," *Trans. Am. Nucl. Soc.*, **26**, 604 (1977).
- [6.1.11] "CASMO-3 A Fuel Assembly Burnup Program, Users Manual," Studsvik/NFA-87/7, Studsvik Energitechnik AB, November 1986.
- [6.1.12] M. Edenius and A. Ahlin, "CASMO-3: New Features, Benchmarking, and Advanced Applications," *Nucl. Sci. Eng.*, **100**, 342-351, (1988).
- [6.1.13] "QA Validation Manual for Computer Code CELLDAN," Holtec International Report HI-90577.
- [6.3.1] "CASMO-4 Methodology", Studsvik/SOA-95/2, Rev. 0, 1995.
- [6.3.2] "CASMO-4 A Fuel Assembly Burnup Program, Users Manual," SSP-01/400, Rev. 1, Studsvik Scandpower, Inc., 2001.
- [6.3.3] "CASMO-4 Benchmark Against Critical Experiments", Studsvik/SOA-94/13, Studsvik of America, 1995.
- [6.4.1] "SCALE 4.3: A Modular System for Performing Standardized Computer Analysis for Licensing Evaluations," NUREG-CR-0200, Rev. 5, Oak Ridge National Laboratory (1995).
- [6.4.2] J.M. Cano, R. Caro, and J.M Martinez-Val, "Supercriticality Through Optimum Moderation in Nuclear Fuel Storage," *Nucl. Technol.*, **48**, 251-260, (1980).

HOLTEC INTERNATIONAL COPYRIGHTED MATERIAL

HI-STORM FSAR
REPORT HI-2002444

6.7-2

Rev. 1

APPENDIX 6.A: BENCHMARK CALCULATIONS

6.A.1 INTRODUCTION AND SUMMARY

Benchmark calculations have been made on selected critical experiments, chosen, in so far as possible, to bound the range of variables in the cask designs. Two independent methods of analysis were used, differing in cross section libraries and in the treatment of the cross sections. MCNP4a [6.A.1] is a continuous energy Monte Carlo code and KENO5a [6.A.2] uses group-dependent cross sections. For the KENO5a analyses reported here, the 238-group library was chosen, processed through the NITAWL-II [6.A.2] program to create a working library and to account for resonance self-shielding in uranium-238 (Nordheim integral treatment). The 238 group library was chosen to avoid or minimize the errors[†] (trends) that have been reported (e.g., [6.A.3 through 6.A.5]) for calculations with collapsed cross section sets.

In cask designs, the three most significant parameters affecting criticality are (1) the fuel enrichment, (2) the ¹⁰B loading in the neutron absorber, and (3) the lattice spacing (or water-gap thickness if a flux-trap design is used). Other parameters, within the normal range of cask and fuel designs, have a smaller effect, but are also included in the analyses.

Table 6.A.1 summarizes results of the benchmark calculations for all cases selected and analyzed, as referenced in the table. The effect of the major variables are discussed in subsequent sections below. It is important to note that there is obviously considerable overlap in parameters since it is not possible to vary a single parameter and maintain criticality; some other parameter or parameters must be concurrently varied to maintain criticality.

One possible way of representing the data is through a spectrum index that incorporates all of the variations in parameters. KENO5a computes and prints the "energy of the average lethargy causing fission". In MCNP4a, by utilizing the tally option with the identical 238-group energy structure as in KENO5a, the number of fissions in each group may be collected and the energy of the average lethargy causing fission determined (post-processing).

Figures 6.A.1 and 6.A.2 show the calculated k_{eff} for the benchmark critical experiments as a function of the "energy of the average lethargy causing fission" for MCNP4a and KENO5a, respectively (UO₂ fuel only). The scatter in the data (even for comparatively minor variation in

[†] Small but observable trends (errors) have been reported for calculations with the 27-group and 44-group collapsed libraries. These errors are probably due to the use of a single collapsing spectrum when the spectrum should be different for the various cases analyzed, as evidenced by the spectrum indices.

HOLTEC INTERNATIONAL COPYRIGHTED MATERIAL

HI-STORM FSAR
REPORT HI-2002444

Appendix 6.A-1

Rev. 2

critical parameters) represents experimental error[†] in performing the critical experiments within each laboratory, as well as between the various testing laboratories. The B&W critical experiments show a larger experimental error than the PNL criticals. This would be expected since the B&W criticals encompass a greater range of critical parameters than the PNL criticals.

Linear regression analysis of the data in Figures 6.A.1 and 6.A.2 show that there are no trends, as evidenced by very low values of the correlation coefficient (0.13 for MCNP4a and 0.21 for KENO5a). The total bias (systematic error, or mean of the deviation from a k_{eff} of exactly 1.000) for the two methods of analysis are shown in the table below.

Calculational Bias of MCNP4a and KENO5a		
	Total	Truncated
MCNP4a	0.0009 ± 0.0011	0.0021 ± 0.0006
KENO5a	0.0030 ± 0.0012	0.0036 ± 0.0009

The values of bias shown in this table include both the bias derived directly from the calculated k_{eff} values in Table 6.A.1, and a more conservative value derived by arbitrarily truncating to 1.000 any calculated value that exceeds 1.000. The bias and standard error of the bias were calculated by the following equations^{††}, with the standard error multiplied by the one-sided K-factor for 95% probability at the 95% confidence level from NBS Handbook 91 [6.A.18] (for the number of cases analyzed, the K-factor is ~2.05 or slightly more than 2).

$$\bar{k} = \frac{1}{n} \sum_{i=1}^n k_i \quad (6.A.1)$$

† A classical example of experimental error is the corrected enrichment in the PNL experiments, first as an addendum to the initial report and, secondly, by revised values in subsequent reports for the same fuel rods.

†† These equations may be found in any standard text on statistics, for example, reference [6.A.6] (or the MCNP4a manual) and is the same methodology used in MCNP4a and in KENO5a.

HOLTEC INTERNATIONAL COPYRIGHTED MATERIAL

$$\sigma_{\bar{k}}^2 = \frac{\sum_{i=1}^n k_i^2 - (\sum_{i=1}^n k_i)^2 / n}{n(n-1)} \quad (6.A.2)$$

$$\text{Bias} = (1 - \bar{k}) \pm K\sigma_{\bar{k}} \quad (6.A.3)$$

where k_i are the calculated reactivities for n critical experiments; $\sigma_{\bar{k}}$ is the unbiased estimator of the standard deviation of the mean (also called the standard error of the bias (mean)); and K is the one-sided multiplier for 95% probability at the 95% confidence level (NBS Handbook 91 [6.A.18]).

Formula 6.A.3 is based on the methodology of the National Bureau of Standards (now NIST) and is used to calculate the values presented on page 6.A-2. The first portion of the equation, $(1 - \bar{k})$, is the actual bias which is added to the MCNP4a and KENO5a results. The second term, $K\sigma_{\bar{k}}$, which corresponds to σ_B in Section 6.4.3, is the uncertainty or standard error associated with the bias. The K values used were obtained from the National Bureau of Standards Handbook 91 and are for one-sided statistical tolerance limits for 95% probability at the 95% confidence level. The actual K values for the 56 critical experiments evaluated with MCNP4a and the 53 critical experiments evaluated with KENO5a are 2.04 and 2.05, respectively.

The larger of the calculational biases (truncated bias) was used to evaluate the maximum k_{eff} values for the cask designs.

6.A.2 Effect of Enrichment

The benchmark critical experiments include those with enrichments ranging from 2.46% to 5.74% and therefore span the enrichment range for the MPC designs. Figures 6.A.3 and 6.A.4 show the calculated k_{eff} values (Table 6.A.1) as a function of the fuel enrichment reported for the critical experiments. Linear regression analyses for these data confirms that there are no trends, as indicated by low values of the correlation coefficients (0.03 for MCNP4a and 0.38 for KENO5a). Thus, there are no corrections to the bias for the various enrichments.

As further confirmation of the absence of any trends with enrichment, the MPC-68 configuration was calculated with both MCNP4a and KENO5a for various enrichments. The cross-comparison of calculations with codes of comparable sophistication is suggested in Reg. Guide 3.41. Results of this comparison, shown in Table 6.A.2 and Figure 6.A.5, confirm no significant difference in the calculated values of k_{eff} for the two independent codes as evidenced by the 45° slope of the curve. Since it is very unlikely that two independent methods of analysis would be subject to the

HOLTEC INTERNATIONAL COPYRIGHTED MATERIAL

same error, this comparison is considered confirmation of the absence of an enrichment effect (trend) in the bias.

6.A.3 Effect of ^{10}B Loading

Several laboratories have performed critical experiments with a variety of thin absorber panels similar to the Boral panels in the cask designs. Of these critical experiments, those performed by B&W are the most representative of the cask designs. PNL has also made some measurements with absorber plates, but, with one exception (a flux-trap experiment), the reactivity worth of the absorbers in the PNL tests is very low and any significant errors that might exist in the treatment of strong thin absorbers could not be revealed.

Table 6.A.3 lists the subset of experiments using thin neutron absorbers (from Table 6.A.1) and shows the reactivity worth (Δk) of the absorber.[†]

No trends with reactivity worth of the absorber are evident, although based on the calculations shown in Table 6.A.3, some of the B&W critical experiments seem to have unusually large experimental errors. B&W made an effort to report some of their experimental errors. Other laboratories did not evaluate their experimental errors.

To further confirm the absence of a significant trend with ^{10}B concentration in the absorber, a cross-comparison was made with MCNP4a and KENO5a (as suggested in Reg. Guide 3.41). Results are shown in Figure 6.A.6 and Table 6.A.4 for the MPC-68 cask^{††} geometry. These data substantiate the absence of any error (trend) in either of the two codes for the conditions analyzed (data points fall on a 45° line, within an expected 95% probability limit).

† The reactivity worth of the absorber panels was determined by repeating the calculation with the absorber analytically removed and calculating the incremental (Δk) change in reactivity due to the absorber.

†† The MPC-68 geometry was chosen for this comparison since it contains the greater number of Boral panels and would therefore be expected to be the most sensitive to trends (errors) in calculations.

6.A.4 Miscellaneous and Minor Parameters

6.A.4.1 Reflector Material and Spacings

PNL has performed a number of critical experiments with thick steel and lead reflectors.[†] Analysis of these critical experiments are listed in Table 6.A.5 (subset of data in Table 6.A.1). There appears to be a small tendency toward overprediction of k_{eff} at the lower spacing, although there are an insufficient number of data points in each series to allow a quantitative determination of any trends. The tendency toward overprediction at close spacing means that the cask calculations may be slightly more conservative than otherwise.

6.A.4.2 Fuel Pellet Diameter and Lattice Pitch

The critical experiments selected for analysis cover a range of fuel pellet diameters from 0.311 to 0.444 inches, and lattice spacings from 0.476 to 1.00 inches. In the cask designs, the fuel pellet diameters range from 0.303 to 0.3835 inches O.D. (0.496 to 0.580 inch lattice spacing) for PWR fuel and from 0.3224 to 0.498 inches O.D. (0.488 to 0.740 inch lattice spacing) for BWR fuel. Thus, the critical experiments analyzed provide a reasonable representation of the fuel in the MPC designs. Based on the data in Table 6.A.1, there does not appear to be any observable trend with either fuel pellet diameter or lattice pitch, at least over the range of the critical experiments or the cask designs.

6.A.4.3 Soluble Boron Concentration Effects

Various soluble boron concentrations were used in the B&W series of critical experiments and in one PNL experiment, with boron concentrations ranging up to 2550 ppm. Results of MCNP4a (and one KENO5a) calculations are shown in Table 6.A.6. Analyses of the very high boron concentration experiments (>1300 ppm) show a tendency to slightly overpredict reactivity for the three experiments exceeding 1300 ppm. In turn, this would suggest that the evaluation of the MPC-32 with various soluble boron concentration could be slightly conservative for the high soluble boron concentration.

6.A.5 MOX Fuel

[†]Parallel experiments with a depleted uranium reflector were also performed but not included in the present analysis since they are not pertinent to the Holtec cask design. A lead reflector is also not directly pertinent, but might be used in future designs.

The number of critical experiments with PuO₂ bearing fuel (MOX) is more limited than for UO₂ fuel. However, a number of MOX critical experiments have been analyzed and the results are shown in Table 6.A.7. Results of these analyses are generally above a k_{eff} of 1.00, indicating that when Pu is present, MCNP4a and KENO5a overpredict the reactivity.

This may indicate that calculation for MOX fuel will be expected to be conservative, especially with MCNP4a. It may be noted that for the larger lattice spacings, the KENO5a calculated reactivities are below 1.00, suggested that a small trend may exist with KENO5a. It is also possible that the overprediction in k_{eff} in both codes may be due to a small inadequacy in the determination of the Pu-241 decay and Am-241 growth. This possibility is supported by the consistency in calculated k_{eff} over a wide range of the spectral index (energy of the average lethargy causing fission).

6.A.6 References

- [6.A.1] J.F. Briesmeister, Ed., "MCNP - A General Monte Carlo N-Particle Transport Code, Version 4A; Los Alamos National Laboratory, LA-12625-M (1993).
- [6.A.2] SCALE 4.3, "A Modular Code System for Performing Standardized Computer Analyses for Licensing Evaluation", NUREG-0200 (ORNL-NUREG-CSD-2/U2/R5, Revision 5, Oak Ridge National Laboratory, September 1995).
- [6.A.3] M.D. DeHart and S.M. Bowman, "Validation of the SCALE Broad Structure 44-Group ENDF/B-V Cross-Section Library for Use in Criticality Safety Analyses", NUREG/CR-6102 (ORNL/TM-12460) Oak Ridge National Laboratory, September 1994.
- [6.A.4] W.C. Jordan et al., "Validation of KENO5.a", CSD/TM-238, Martin Marietta Energy Systems, Inc., Oak Ridge National Laboratory, December 1986.
- [6.A.5] O.W. Hermann et al., "Validation of the Scale System for PWR Spent Fuel Isotopic Composition Analysis", ORNL-TM-12667, Oak Ridge National Laboratory, undated.
- [6.A.6] R.J. Larsen and M.L. Marx, An Introduction to Mathematical Statistics and its Applications, Prentice-Hall, 1986.

HOLTEC INTERNATIONAL COPYRIGHTED MATERIAL

- [6.A.7] M.N. Baldwin et al., Critical Experiments Supporting Close Proximity Water Storage of Power Reactor Fuel, BAW-1484-7, Babcock and Wilcox Company, July 1979.
- [6.A.8] G.S. Hoovier et al., Critical Experiments Supporting Underwater Storage of Tightly Packed Configurations of Spent Fuel Pins, BAW-1645-4, Babcock & Wilcox Company, November 1991.
- [6.A.9] L.W. Newman et al., Urania Gadolinia: Nuclear Model Development and Critical Experiment Benchmark, BAW-1810, Babcock and Wilcox Company, April 1984.
- [6.A.10] J.C. Manaranche et al., "Dissolution and Storage Experimental Program with 4.75% Enriched Uranium-Oxide Rods," Trans. Am. Nucl. Soc. 33: 362-364 (1979).
- [6.A.11] S.R. Bierman and E.D. Clayton, Criticality Experiments with Subcritical Clusters of 2.35 wt % and 4.31 wt % ²³⁵U Enriched UO₂ Rods in Water with Steel Reflecting Walls, PNL-3602, Battelle Pacific Northwest Laboratory, April 1981.
- [6.A.12] S.R. Bierman et al., Criticality Experiments with Subcritical Clusters of 2.35 Wt% and 4.31 Wt% ²³⁵U Enriched UO₂ Rods in Water with Uranium or Lead Reflecting Walls, PNL-3926, Battelle Pacific Northwest Laboratory, December, 1981.
- [6.A.13] S.R. Bierman et al., Critical Separation Between Subcritical Clusters of 4.31 Wt % ²³⁵U Enriched UO₂ Rods in Water with Fixed Neutron Poisons, PNL-2615, Battelle Pacific Northwest Laboratory, October 1977.
- [6.A.14] S.R. Bierman, Criticality Experiments with Neutron Flux Traps Containing Voids, PNL-7167, Battelle Pacific Northwest Laboratory, April 1990.
- [6.A.15] B.M. Durst et al., Critical Experiments with 4.31 wt % ²³⁵U Enriched UO₂ Rods in Highly Borated Water Lattices, PNL-4267, Battelle Pacific Northwest Laboratory, August 1982.

HOLTEC INTERNATIONAL COPYRIGHTED MATERIAL

HI-STORM FSAR
REPORT HI-2002444

Appendix 6.A-7.

Rev. 2

- [6.A.16] S.R. Bierman, Criticality Experiments with Fast Test Reactor Fuel Pins in Organic Moderator, PNL-5803, Battelle Pacific Northwest Laboratory, December 1986.
- [6.A.17] E.G. Taylor et al., Saxton Plutonium Program Critical Experiments for the Saxton Partial Plutonium core, WCAP-3385-54, Westinghouse Electric Corp., Atomic Power Division, December 1965.
- [6.A.18] M.G. Natrella, Experimental Statistics, National Bureau of Standards, Handbook 91, August 1963.

HOLTEC INTERNATIONAL COPYRIGHTED MATERIAL

HI-STORM FSAR
REPORT HI-2002444

Appendix 6.A-8

Rev. 2

HI-STORM 100 FSAR, NON-PROPRIETARY
REVISION 12
MARCH 12, 2014

Table 6.A.1
Summary of Criticality Benchmark Calculations

Reference	Identification	Enrich.	Calculated k_{eff}		EALF (eV)		
			MCNP4a	KENO5a	MCNP4a	KENO5a	
1	B&W-1484 (6.A.7)	Core I	2.46	0.9964 ± 0.0010	0.9898 ± 0.0006	0.1759	0.1753
2	B&W-1484 (6.A.7)	Core II	2.46	1.0008 ± 0.0011	1.0015 ± 0.0005	0.2553	0.2446
3	B&W-1484 (6.A.7)	Core III	2.46	1.0010 ± 0.0012	1.0005 ± 0.0005	0.1999	0.1939
4	B&W-1484 (6.A.7)	Core IX	2.46	0.9956 ± 0.0012	0.9901 ± 0.0006	0.1422	0.1426
5	B&W-1484 (6.A.7)	Core X	2.46	0.9980 ± 0.0014	0.9922 ± 0.0006	0.1513	0.1499
6	B&W-1484 (6.A.7)	Core XI	2.46	0.9978 ± 0.0012	1.0005 ± 0.0005	0.2031	0.1947
7	B&W-1484 (6.A.7)	Core XII	2.46	0.9988 ± 0.0011	0.9978 ± 0.0006	0.1718	0.1662
8	B&W-1484 (6.A.7)	Core XIII	2.46	1.0020 ± 0.0010	0.9952 ± 0.0006	0.1988	0.1965
9	B&W-1484 (6.A.7)	Core XIV	2.46	0.9953 ± 0.0011	0.9928 ± 0.0006	0.2022	0.1986
10	B&W-1484 (6.A.7)	Core XV ^{††}	2.46	0.9910 ± 0.0011	0.9909 ± 0.0006	0.2092	0.2014
11	B&W-1484 (6.A.7)	Core XVI ^{††}	2.46	0.9935 ± 0.0010	0.9889 ± 0.0006	0.1757	0.1713
12	B&W-1484 (6.A.7)	Core XVII	2.46	0.9962 ± 0.0012	0.9942 ± 0.0005	0.2083	0.2021

HOLTEC INTERNATIONAL COPYRIGHTED MATERIAL

Table 6.A.1
Summary of Criticality Benchmark Calculations

Reference	Identification	Enrich.	Calculated k_{eff}		EALF (eV)		
			MCNP4a	KENO5a	MCNP4a	KENO5a	
13	B&W-1484 (6.A.7)	Core XVIII	2.46	1.0036 ± 0.0012	0.9931 ± 0.0006	0.1705	0.1708
14	B&W-1484 (6.A.7)	Core XIX	2.46	0.9961 ± 0.0012	0.9971 ± 0.0005	0.2103	0.2011
15	B&W-1484 (6.A.7)	Core XX	2.46	1.0008 ± 0.0011	0.9932 ± 0.0006	0.1724	0.1701
16	B&W-1484 (6.A.7)	Core XXI	2.46	0.9994 ± 0.0010	0.9918 ± 0.0006	0.1544	0.1536
17	B&W-1645 (6.A.8)	S-type Fuel, w/886 ppm B	2.46	0.9970 ± 0.0010	0.9924 ± 0.0006	1.4475	1.4680
18	B&W-1645 (6.A.8)	S-type Fuel, w/746 ppm B	2.46	0.9990 ± 0.0010	0.9913 ± 0.0006	1.5463	1.5660
19	B&W-1645 (6.A.8)	SO-type Fuel, w/1156 ppm B	2.46	0.9972 ± 0.0009	0.9949 ± 0.0005	0.4241	0.4331
20	B&W-1810 (6.A.9)	Case 1 1337 ppm B	2.46	1.0023 ± 0.0010	NC	0.1531	NC
21	B&W-1810 (6.A.9)	Case 12 1899 ppm B	2.46/4.02	1.0060 ± 0.0009	NC	0.4493	NC
22	French (6.A.10)	Water Moderator 0 gap	4.75	0.9966 ± 0.0013	NC	0.2172	NC
23	French (6.A.10)	Water Moderator 2.5 cm gap	4.75	0.9952 ± 0.0012	NC	0.1778	NC
24	French (6.A.10)	Water Moderator 5 cm gap	4.75	0.9943 ± 0.0010	NC	0.1677	NC

HOLTEC INTERNATIONAL COPYRIGHTED MATERIAL

Table 6.A.1
Summary of Criticality Benchmark Calculations

Reference	Identification	Enrich.	Calculated k_{eff}		EALF (eV)		
			MCNP4a	KENO5a	MCNP4a	KENO5a	
25	French (6.A.10)	Water Moderator 10 cm gap	4.75	0.9979 ± 0.0010	NC	0.1736	NC
26	PNL-3602 (6.A.11)	Steel Reflector, 0 cm separation	2.35	NC	1.0004 ± 0.0006	NC	0.1018
27	PNL-3602 (6.A.11)	Steel Reflector, 1.321 cm separation	2.35	0.9980 ± 0.0009	0.9992 ± 0.0006	0.1000	0.0909
28	PNL-3602 (6.A.11)	Steel Reflector, 2.616 cm separation	2.35	0.9968 ± 0.0009	0.9964 ± 0.0006	0.0981	0.0975
29	PNL-3602 (6.A.11)	Steel Reflector, 3.912 cm separation	2.35	0.9974 ± 0.0010	0.9980 ± 0.0006	0.0976	0.0970
30	PNL-3602 (6.A.11)	Steel Reflector, Infinite separation	2.35	0.9962 ± 0.0008	0.9939 ± 0.0006	0.0973	0.0968
31	PNL-3602 (6.A.11)	Steel Reflector, 0 cm separation	4.306	NC	1.0003 ± 0.0007	NC	0.3282
32	PNL-3602 (6.A.11)	Steel Reflector, 1.321 cm separation	4.306	0.9997 ± 0.0010	1.0012 ± 0.0007	0.3016	0.3039
33	PNL-3602 (6.A.11)	Steel Reflector, 2.616 cm separation	4.306	0.9994 ± 0.0012	0.9974 ± 0.0007	0.2911	0.2927
34	PNL-3602 (6.A.11)	Steel Reflector, 5.405 cm separation	4.306	0.9969 ± 0.0011	0.9951 ± 0.0007	0.2828	0.2860
35	PNL-3602 (6.A.11)	Steel Reflector, Infinite separation	4.306	0.9910 ± 0.0020	0.9947 ± 0.0007	0.2851	0.2864
36	PNL-3602 (6.A.11)	Steel Reflector, with Boral Sheets	4.306	0.9941 ± 0.0011	0.9970 ± 0.0007	0.3135	0.3150

HOLTEC INTERNATIONAL COPYRIGHTED MATERIAL

Table 6.A.1
Summary of Criticality Benchmark Calculations

Reference	Identification	Enrich.	Calculated k_{eff}		EALF (eV)		
			MCNP4a	KENO5a	MCNP4a	KENO5a	
37	PNL-3626 (6.A.12)	Lead Reflector, 0 cm sepn.	4.306	NC	1.0003 ± 0.0007	NC	0.3159
38	PNL-3626 (6.A.12)	Lead Reflector, 0.55 cm sepn.	4.306	1.0025 ± 0.0011	0.9997 ± 0.0007	0.3030	0.3044
39	PNL-3626 (6.A.12)	Lead Reflector, 1.956 cm sepn.	4.306	1.0000 ± 0.0012	0.9985 ± 0.0007	0.2883	0.2930
40	PNL-3626 (6.A.12)	Lead Reflector, 5.405 cm sepn.	4.306	0.9971 ± 0.0012	0.9946 ± 0.0007	0.2831	0.2854
41	PNL-2615 (6.A.13)	Experiment 004/032 – no absorber	4.306	0.9925 ± 0.0012	0.9950 ± 0.0007	0.1155	0.1159
42	PNL-2615 (6.A.13)	Experiment 030 – Zr plates	4.306	NC	0.9971 ± 0.0007	NC	0.1154
43	PNL-2615 (6.A.13)	Experiment 013 – Steel plates	4.306	NC	0.9965 ± 0.0007	NC	0.1164
44	PNL-2615 (6.A.13)	Experiment 014 – Steel plates	4.306	NC	0.9972 ± 0.0007	NC	0.1164
45	PNL-2615 (6.A.13)	Exp. 009 1.05% Boron Steel plates	4.306	0.9982 ± 0.0010	0.9981 ± 0.0007	0.1172	0.1162
46	PNL-2615 (6.A.13)	Exp. 009 1.62% Boron Steel plates	4.306	0.9996 ± 0.0012	0.9982 ± 0.0007	0.1161	0.1173
47	PNL-2615 (6.A.13)	Exp. 031 – Boral plates	4.306	0.9994 ± 0.0012	0.9969 ± 0.0007	0.1165	0.1171
48	PNL-7167 (6.A.14)	Experiment 214R – with flux traps	4.306	0.9991 ± 0.0011	0.9956 ± 0.0007	0.3722	0.3812

HOLTEC INTERNATIONAL COPYRIGHTED MATERIAL

Table 6.A.1
Summary of Criticality Benchmark Calculations

Reference	Identification	Enrich.	Calculated k_{eff}		EALF (eV)		
			MCNP4a	KENO5a	MCNP4a	KENO5a	
49	PNL-7167 (6.A.14)	Experiment 214V3 –with flux trap	4.306	0.9969 ± 0.0011	0.9963 ± 0.0007	0.3742	0.3826
50	PNL-4267 (6.A.15)	Case 173 – 0 ppm B	4.306	0.9974 ± 0.0012	NC	0.2893	NC
51	PNL-4267 (6.A.15)	Case 177 – 2550 ppm B	4.306	1.0057 ± 0.0010	NC	0.5509	NC
52	PNL-5803 (6.A.16)	MOX Fuel – Type 3.2 Exp. 21	20% Pu	1.0041 ± 0.0011	1.0046 ± 0.0006	0.9171	0.8868
53	PNL-5803 (6.A.16)	MOX Fuel – Type 3.2 Exp. 43	20% Pu	1.0058 ± 0.0012	1.0036 ± 0.0006	0.2968	0.2944
54	PNL-5803 (6.A.16)	MOX Fuel – Type 3.2 Exp. 13	20% Pu	1.0083 ± 0.0011	0.9989 ± 0.0006	0.1665	0.1706
55	PNL-5803 (6.A.16)	MOX Fuel – Type 3.2 Exp. 32	20% Pu	1.0079 ± 0.0011	0.9966 ± 0.0006	0.1339	0.1165
56	WCAP-3385 (6.A.17)	Saxton Case 52 PuO ₂ 0.52” pitch	6.6% Pu	0.9996 ± 0.0011	1.0005 ± 0.0006	0.8665	0.8417
57	WCAP-3385 (6.A.17)	Saxton Case 52 U 0.52” pitch	5.74	1.0000 ± 0.0010	0.9956 ± 0.0007	0.4476	0.4580
58	WCAP-3385 (6.A.17)	Saxton Case 56 PuO ₂ 0.56” pitch	6.6% Pu	1.0036 ± 0.0011	1.0047 ± 0.0006	0.5289	0.5197
59	WCAP-3385 (6.A.17)	Saxton Case 56 borated PuO ₂	6.6% Pu	1.0008 ± 0.0010	NC	0.6389	NC
60	WCAP-3385 (6.A.17)	Saxton Case 56 U 0.56” pitch	5.74	0.9994 ± 0.0011	0.9967 ± 0.0007	0.2923	0.2954

HOLTEC INTERNATIONAL COPYRIGHTED MATERIAL

Table 6.A.1
Summary of Criticality Benchmark Calculations

Reference	Identification	Enrich.	Calculated k_{eff}		EALF (eV)		
			MCNP4a	KENO5a	MCNP4a	KENO5a	
61	WCAP-3385 (6.A.17)	Saxton Case 79 PuO ₂ 0.79" pitch	6.6% Pu	1.0063 ± 0.0011	1.0133 ± 0.0006	0.1520	0.1555
62	WCAP-3385 (6.A.17)	Saxton Case 79 U 0.79" pitch	5.74	1.0039 ± 0.0011	1.0008 ± 0.0006	0.1036	0.1047

Notes: NC stands for not calculated.

† EALF is the energy of the average lethargy causing fission

†† The experimental results appear to be statistical outliers ($>3\sigma$) suggesting the possibility of unusually large experimental error. Although they could be justifiably excluded, for conservatism, they were retained in determining the calculational basis.

HOLTEC INTERNATIONAL COPYRIGHTED MATERIAL

Table 6.A.2

COMPARISON OF MCNP4a AND KENO5a CALCULATED REACTIVITIES[†]
FOR VARIOUS ENRICHMENTS (UO₂)

Enrichment	Calculated $k_{eff} \pm 1\sigma$	
	MCNP4a	KENO5a
3.0	0.8465 ± 0.0011	0.8478 ± 0.0004
3.5	0.8820 ± 0.0011	0.8841 ± 0.0004
3.75	0.9019 ± 0.0011	0.8987 ± 0.0004
4.0	0.9132 ± 0.0010	0.9140 ± 0.0004
4.2	0.9276 ± 0.0011	0.9237 ± 0.0004
4.5	0.9400 ± 0.0011	0.9388 ± 0.0004

[†] Based on the MPC-68 with the GE 8x8R

HOLTEC INTERNATIONAL COPYRIGHTED MATERIAL

Table 6.A.3

MCNP4a CALCULATED REACTIVITIES FOR
CRITICAL EXPERIMENTS WITH NEUTRON ABSORBERS (UO₂)

Ref.	Experiment		Δk Worth of Absorber	MCNP4a Calculated k_{eff}	EALF [†] (eV)
6.A.13	PNL-2615	Boral Sheet	0.0139	0.9994 ± 0.0012	0.1165
6.A.7	BAW-1484	Core XX	0.0165	1.0008 ± 0.0011	0.1724
6.A.13	PNL-2615	1.62% Boron-steel	0.0165	0.9996 ± 0.0012	0.1161
6.A.7	BAW-1484	Core XIX	0.0202	0.9961 ± 0.0012	0.2103
6.A.7	BAW-1484	Core XXI	0.0243	0.9994 ± 0.0010	0.1544
6.A.7	BAW-1484	Core XVII	0.0519	0.9962 ± 0.0012	0.2083
6.A.11	PNL-3602	Boral Sheet	0.0708	0.9941 ± 0.0011	0.3135
6.A.7	BAW-1484	Core XV	0.0786	0.9910 ± 0.0011	0.2092
6.A.7	BAW-1484	Core XVI	0.0845	0.9935 ± 0.0010	0.1757
6.A.7	BAW-1484	Core XIV	0.1575	0.9953 ± 0.0011	0.2022
6.A.7	BAW-1484	Core XIII	0.1738	1.0020 ± 0.0011	0.1988
6.A.14	PNL-7167	Expt 214R flux trap	0.1931	0.9991 ± 0.0011	0.3722

[†] EALF is the energy of the average lethargy causing fission

HOLTEC INTERNATIONAL COPYRIGHTED MATERIAL

Table 6.A.4
 COMPARISON OF MCNP4a AND KENO5a
 CALCULATED REACTIVITIES[†] FOR VARIOUS BORON LOADINGS (UO₂)

¹⁰ B, g/cm ²	Calculated $k_{eff} \pm 1\sigma$	
	MCNP4a	KENO5a
0.005	1.0381 ± 0.0012	1.0340 ± 0.0004
0.010	0.9960 ± 0.0010	0.9941 ± 0.0004
0.015	0.9727 ± 0.0009	0.9713 ± 0.0004
0.020	0.9541 ± 0.0012	0.9560 ± 0.0004
0.025	0.9433 ± 0.0011	0.9428 ± 0.0004
0.03	0.9325 ± 0.0011	0.9338 ± 0.0004
0.035	0.9234 ± 0.0011	0.9251 ± 0.0004
0.04	0.9173 ± 0.0011	0.9179 ± 0.0004

[†] based on 4.5% enrichment GE 8x8R in the MPC-68 cask.

HOLTEC INTERNATIONAL COPYRIGHTED MATERIAL

Table 6.A.5

CALCULATIONS FOR CRITICAL EXPERIMENTS WITH
THICK LEAD AND STEEL REFLECTORS[†] (UO₂)

Ref.	Case	Enrichment, wt%	Separation, cm	MCNP4a k_{eff}	KENO5a k_{eff}
6.A.11	Steel Reflector	2.35	1.321	0.9980 ± 0.0009	0.9992 ± 0.0006
		2.35	2.616	0.9968 ± 0.0009	0.9964 ± 0.0006
		2.35	3.912	0.9974 ± 0.0010	0.9980 ± 0.0006
		2.35	∞	0.9962 ± 0.0008	0.9939 ± 0.0006
6.A.11	Steel Reflector	4.306	1.321	0.9997 ± 0.0010	1.0012 ± 0.0007
		4.306	2.616	0.9994 ± 0.0012	0.9974 ± 0.0007
		4.306	3.405	0.9969 ± 0.0011	0.9951 ± 0.0007
		4.306	∞	0.9910 ± 0.0020	0.9947 ± 0.0007
6.A.11	Lead Reflector	4.306	0.55	1.0025 ± 0.0011	0.9997 ± 0.0007
		4.306	1.956	1.0000 ± 0.0012	0.9985 ± 0.0007
		4.306	5.405	0.9971 ± 0.0012	0.9946 ± 0.0007

[†] Arranged in order of increasing reflector fuel spacing.

HOLTEC INTERNATIONAL COPYRIGHTED MATERIAL

HI-STORM FSAR
REPORT HI-2002444

Appendix 6.A-18

Rev. 2

Table 6.A.6

CALCULATIONS FOR CRITICAL EXPERIMENTS WITH VARIOUS SOLUBLE
BORON CONCENTRATIONS (UO₂)

Reference	Experiment	Boron Concentration ppm	Calculated k _{eff}	
			MCNP4a	KENO5a
6.A.15	PNL-4267	0	0.9974 ± 0.0012	-
6.A.8	BAW-1645-4	886	0.9970 ± 0.0010	0.9924 ± 0.0006
6.A.9	BAW-1810	1337	1.0023 ± 0.0010	-
6.A.9	BAW-1810	1899	1.0060 ± 0.0009	-
6.A.15	PNL-4267	2550	1.0057 ± 0.0010	-

HOLTEC INTERNATIONAL COPYRIGHTED MATERIAL

HI-STORM FSAR
REPORT HI-2002444

Appendix 6.A-19

Rev. 2

Table 6.A.7

CALCULATIONS FOR CRITICAL EXPERIMENTS WITH MOX FUEL

Reference	Case [†]	MCNP4a		KENO 5a	
		k_{eff}	EALF ^{††} (eV)	k_{eff}	EALF ^{††} (eV)
PNL-5803 [6.A.16]	MOX Fuel – Exp No 21	1.0041±0.0011	0.9171	1.0046±0.0006	0.8868
	MOX Fuel – Exp No 43	1.0058±0.0012	0.2968	1.0036±0.0006	0.2944
	MOX Fuel – Exp No 13	1.0083±0.0011	0.1665	0.9989±0.0006	0.1706
	MOX Fuel – Exp No 32	1.0079±0.0011	0.1139	0.9966±0.0006	0.1165
WCAP- 3385- 54 [6.A.17]	Saxton @ 0.52" pitch	0.9996±0.0011	0.8665	1.0005±0.0006	0.8417
	Saxton @ 0.56" pitch	1.0036±0.0011	0.5289	1.0047±0.0006	0.5197
	Saxton @ 0.56" pitch borated	1.0008±0.0010	0.6389	NC	NC
	Saxton @ 0.79" pitch	1.0063±0.0011	0.1520	1.0133±0.0006	0.1555

[†] Arranged in order of increasing lattice spacing.

^{††} EALF is the energy of the average lethargy causing fission.

HOLTEC INTERNATIONAL COPYRIGHTED MATERIAL

HI-STORM FSAR
REPORT HI-2002444

Appendix 6.A-20

Rev. 2

HI-STORM 100 FSAR, NON-PROPRIETARY
REVISION 12
MARCH 12, 2014

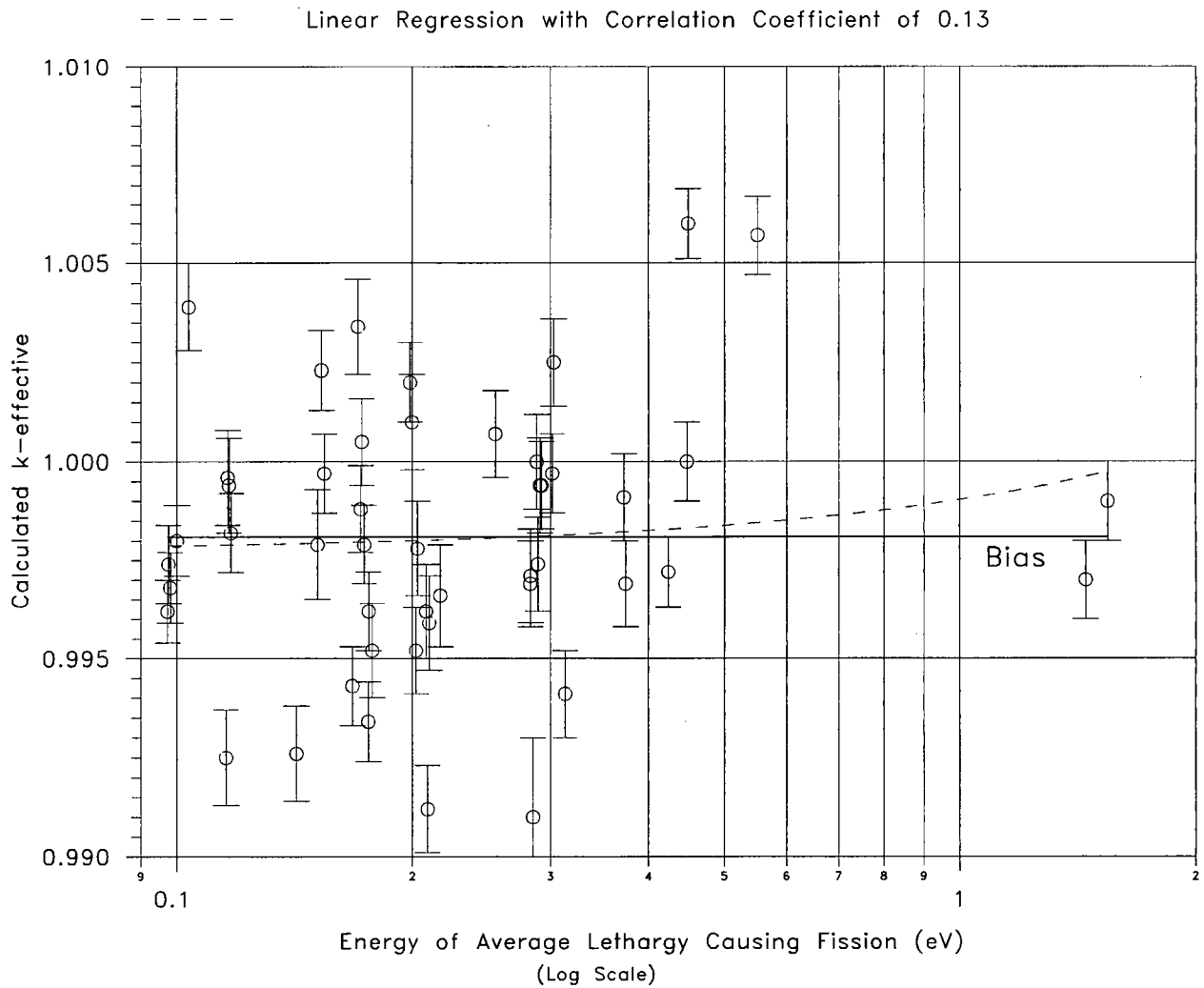


FIGURE 6.A.1 MCNP4a CALCULATED k-eff VALUES FOR VARIOUS VALUES OF THE SPECTRAL INDEX

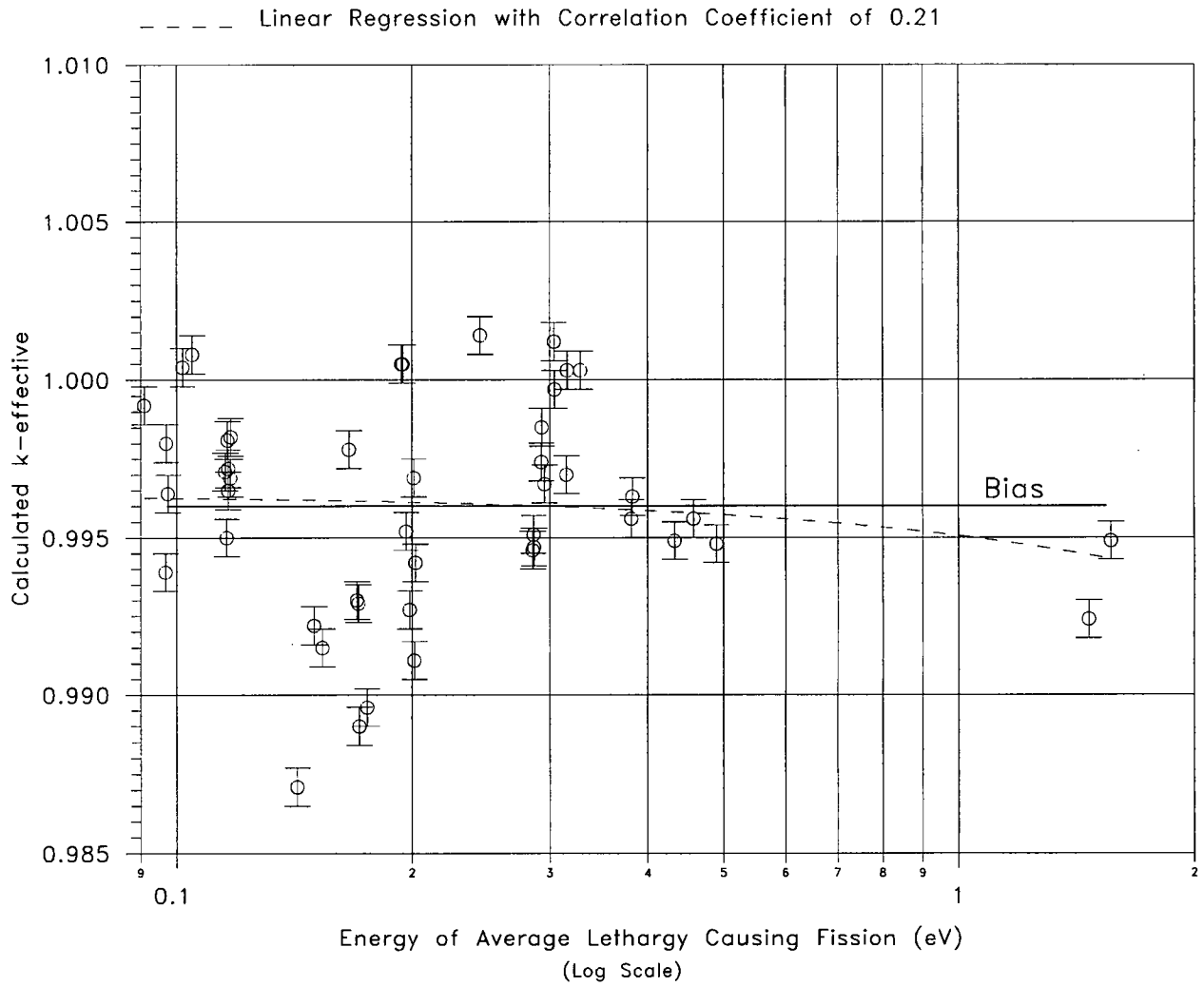


FIGURE 6.A.2 KENO5a CALCULATED k -eff VALUES FOR VARIOUS VALUES OF THE SPECTRAL INDEX

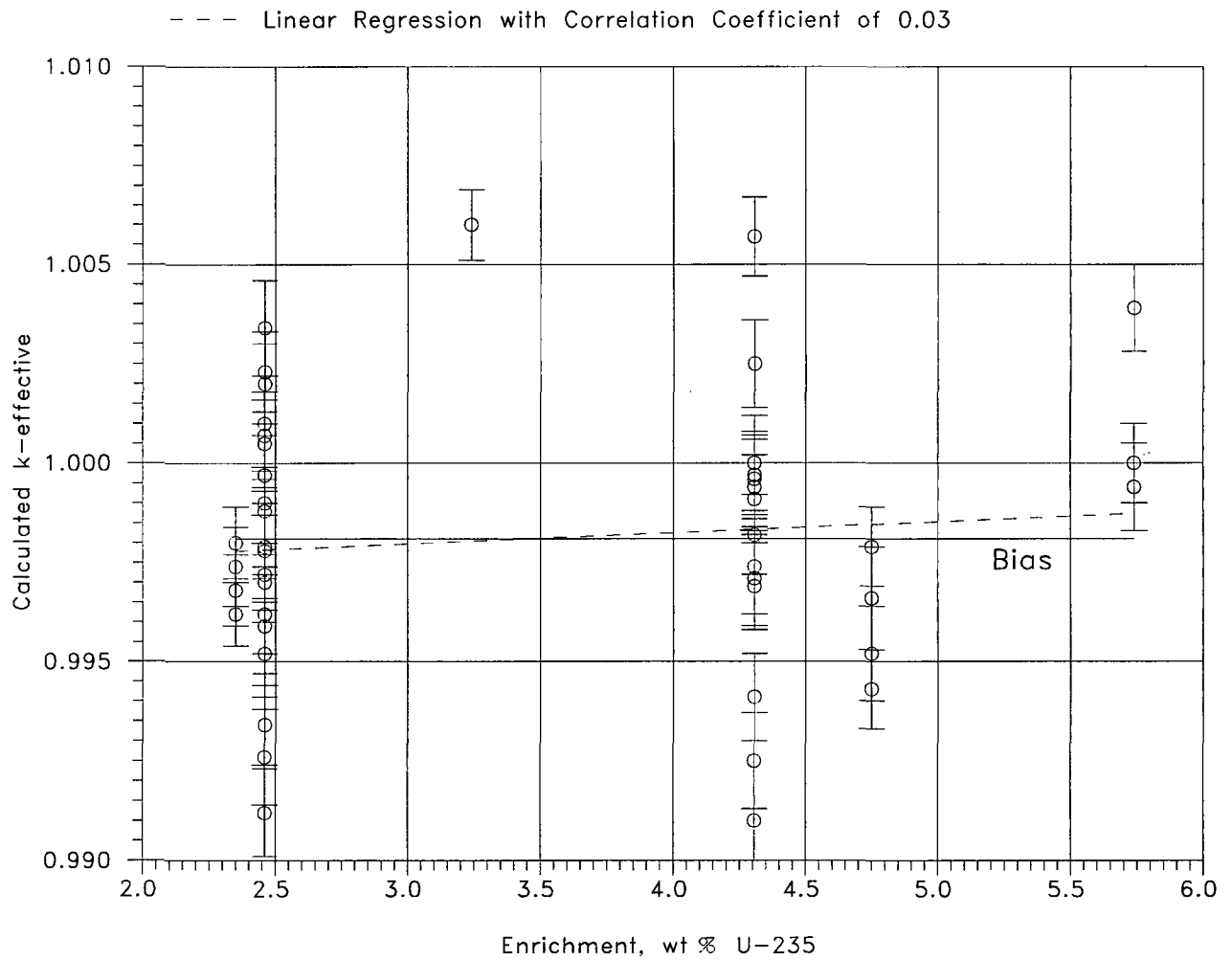


FIGURE 6.A.3 MCNP4a CALCULATED k-eff VALUES AT VARIOUS U-235 ENRICHMENTS

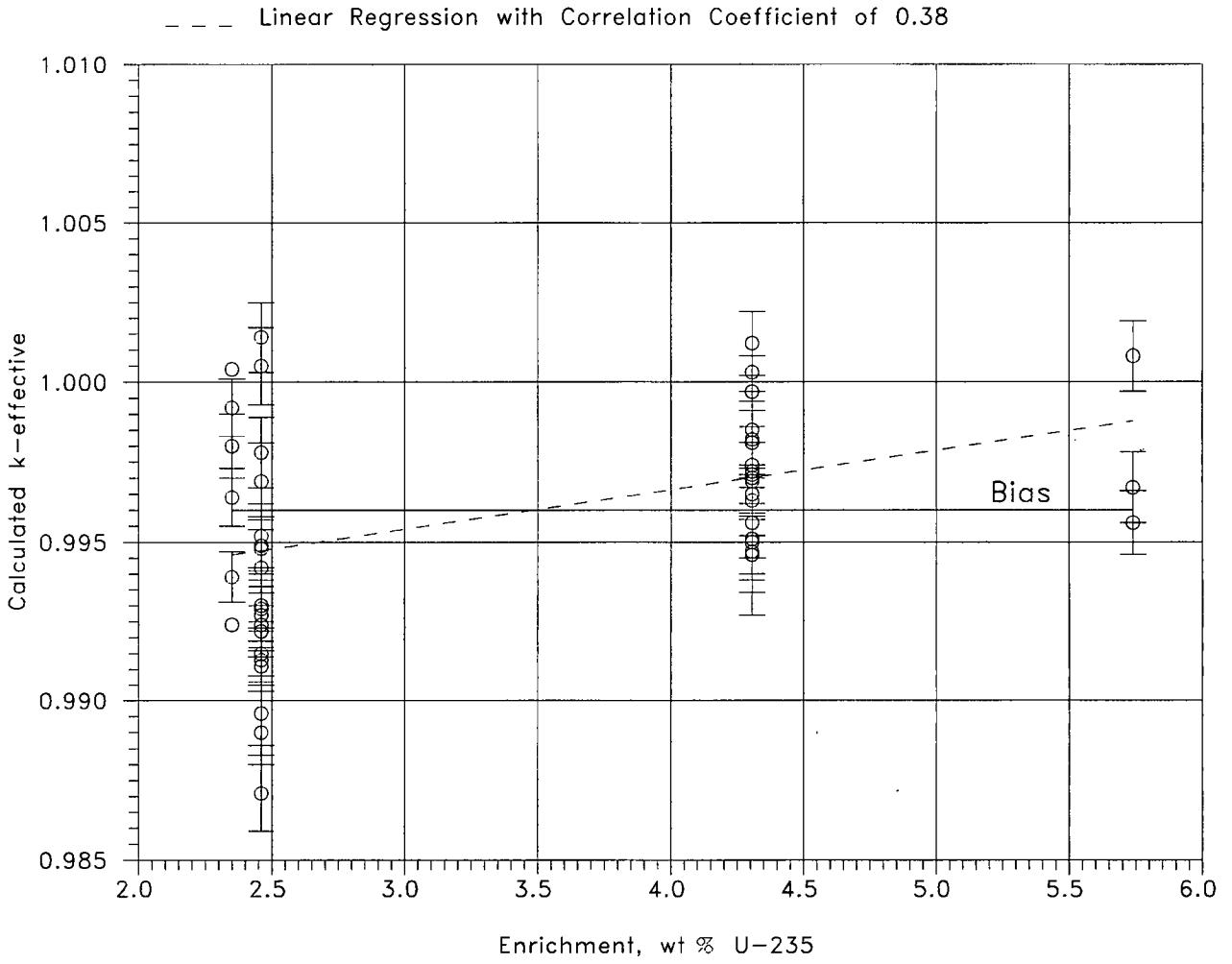


FIGURE 6.A.4 KENO5a CALCULATED k-eff VALUES AT VARIOUS U-235 ENRICHMENTS

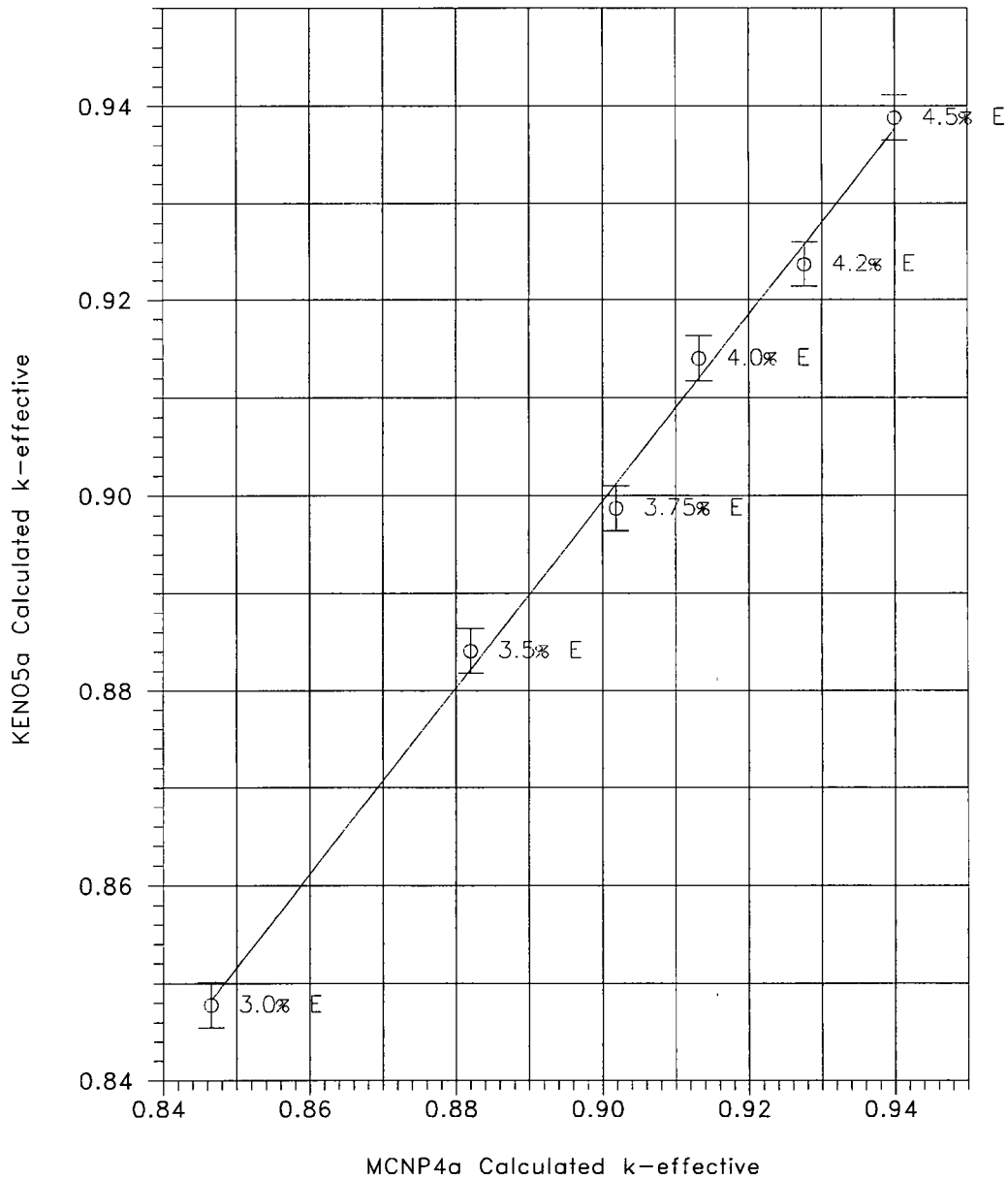


FIGURE 6.A.5 COMPARISON OF MCNP4a AND KENO5a CALCULATIONS FOR VARIOUS FUEL ENRICHMENTS

HI-STORM FSAR

Rev. 0

REPORT HI-2002444

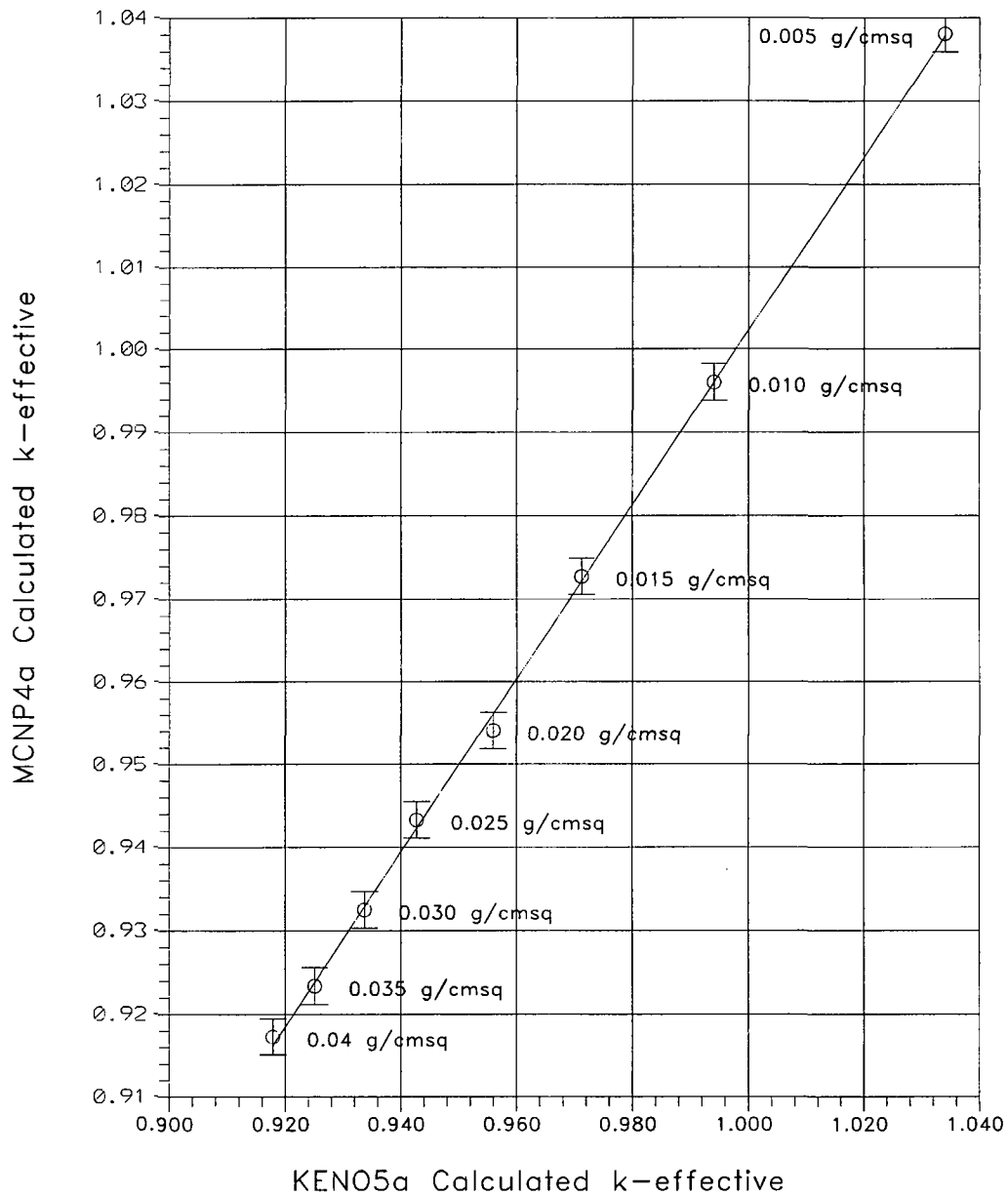


FIGURE 6.A.6 COMPARISON OF MCNP4a AND KENO5a CALCULATIONS FOR VARIOUS BORON-10 AREAL DENSITIES

APPENDIX 6.B: DISTRIBUTED ENRICHMENTS IN BWR FUEL

Fuel assemblies used in BWRs utilize fuel rods of varying enrichments as a means of controlling power peaking during in-core operation. For calculations involving BWR assemblies, the use of a uniform (planar-average) enrichment, as opposed to the distributed enrichments normally used in BWR fuel, produces conservative results. Calculations have been performed to confirm that this statement remains valid in the geometry of the MPC-68. These calculations are based on fuel assembly designs currently in use and two hypothetical distributions, all intended to illustrate that calculations with uniform average enrichments are conservative.

The average enrichment is calculated as the linear average of the various fuel rod enrichments, i.e.,

$$\bar{E} = \frac{1}{n} \sum_{i=1}^n E_i,$$

where E_i is the enrichment in each of the n rods, and \bar{E} is the assembly average enrichment. This parameter conservatively characterizes the fuel assembly and is readily available for specific fuel assemblies in determining the acceptability of the assembly for placement in the MPC-68 cask.

The criticality calculations for average and distributed enrichment cases are compared in Table 6.B.1 to illustrate and confirm the conservatism inherent in using average enrichments. With two exceptions, the cases analyzed represent realistic designs currently in use and encompass fuel with different ratios of maximum pin enrichment to average assembly enrichment. The two exceptions are hypothetical cases intended to extend the models to higher enrichments and to demonstrate that using the average enrichment remains conservative.

Table 6.B.1 shows that, in all cases, the averaged enrichment yields conservative values of reactivity relative to distributed enrichments for both the actual fuel designs and the hypothetical higher enrichment cases. Thus, it is concluded that uniform average enrichments will always yield higher (more conservative) values for reactivity than the corresponding distributed enrichments.[†]

[†] This conclusion implicitly assumes the higher enrichment fuel rods are located internal to the assembly (as in BWR fuel), and the lower enriched rods are on the outside.

HOLTEC INTERNATIONAL COPYRIGHTED MATERIAL

HI-STORM FSAR

Rev. 0

REPORT HI-2002444

Appendix 6:B-1

Table 6.B.1

COMPARISON CALCULATIONS FOR BWR FUEL WITH AVERAGE AND
DISTRIBUTED ENRICHMENTS

Case	Average %E	Peak Rod E%	Calculated k_{eff}	
			Average E	Distributed E
8x8C04	3.01	3.80	0.8549	0.8429
8x8C04	3.934	4.9	0.9128	0.9029
8x8D05	3.42	3.95	0.8790	0.8708
8x8D05	3.78	4.40	0.9030	0.8974
8x8D05	3.90	4.90	0.9062	0.9042
9x9B01	4.34	4.71	0.9347	0.9285
9x9D01	3.35	4.34	0.8793	0.8583
Hypothetical #1 (48 outer rods of 3.967%E, 14 inner rods of 5.0%)	4.20	5.00	0.9289	0.9151
Hypothetical #2 (48 outer rods of 4.354%E, 14 inner rods of 5.0%)	4.50	5.00	0.9422	0.9384

HOLTEC INTERNATIONAL COPYRIGHTED MATERIAL

HI-STORM FSAR
REPORT HI-2002444

Appendix 6.B-2

Rev. 0

APPENDIX 6.C: CALCULATIONAL SUMMARY

The following table lists the maximum k_{eff} (including bias, uncertainties, and calculational statistics), MCNP calculated k_{eff} , standard deviation, and energy of average lethargy causing fission (EALF) for each of the candidate fuel types and basket configurations.

Table 6.C.1
CALCULATIONAL SUMMARY FOR ALL CANDIDATE FUEL TYPES
AND BASKET CONFIGURATIONS

MPC-24					
Fuel Assembly Designation	Cask	Maximum k_{eff}	Calculated k_{eff}	Std. Dev. (1-sigma)	EALF (eV)
14x14A01	HI-STAR	0.9295	0.9252	0.0008	0.2084
14x14A02	HI-STAR	0.9286	0.9242	0.0008	0.2096
14x14A03	HI-STORM	0.3080	0.3047	0.0003	3.37E+04
14x14A03	HI-TRAC	0.9283	0.9239	0.0008	0.2096
14x14A03	HI-STAR	0.9296	0.9253	0.0008	0.2093
14x14B01	HI-STAR	0.9159	0.9117	0.0007	0.2727
14x14B02	HI-STAR	0.9169	0.9126	0.0008	0.2345
14x14B03	HI-STAR	0.9110	0.9065	0.0009	0.2545
14x14B04	HI-STAR	0.9084	0.9039	0.0009	0.2563
B14x14B01	HI-TRAC	0.9237	0.9193	0.0008	0.2669
B14x14B01	HI-STAR	0.9228	0.9185	0.0008	0.2675
14x14C01	HI-TRAC	0.9273	0.9230	0.0008	0.2758
14x14C01	HI-STAR	0.9258	0.9215	0.0008	0.2729
14x14C02	HI-STAR	0.9265	0.9222	0.0008	0.2765
14x14C03	HI-TRAC	0.9274	0.9231	0.0008	0.2839
14x14C03	HI-STAR	0.9287	0.9242	0.0009	0.2825

HOLTEC INTERNATIONAL COPYRIGHTED MATERIAL

HI-STORM FSAR
REPORT HI-2002444

Appendix 6.C-1

Rev. 11

Table 6.C.1 (continued)
 CALCULATIONAL SUMMARY FOR ALL CANDIDATE FUEL TYPES
 AND BASKET CONFIGURATIONS

MPC-24					
Fuel Assembly Designation	Cask	Maximum k_{eff}	Calculated k_{eff}	Std. Dev. (1-sigma)	EALF (eV)
14x14D01	HI-TRAC	0.8531	0.8488	0.0008	0.3316
14x14D01	HI-STAR	0.8507	0.8464	0.0008	0.3308
14x14E01	HI-STAR	0.7598	0.7555	0.0008	0.3890
14x14E02	HI-TRAC	0.7627	0.7586	0.0007	0.3591
14x14E02	HI-STAR	0.7627	0.7586	0.0007	0.3607
14x14E03	HI-STAR	0.6952	0.6909	0.0008	0.2905
15x15A01	HI-TRAC	0.9205	0.9162	0.0008	0.2595
15x15A01	HI-STAR	0.9204	0.9159	0.0009	0.2608
15x15B01	HI-STAR	0.9369	0.9326	0.0008	0.2632
15C15B02	HI-STAR	0.9338	0.9295	0.0008	0.2640
15x15B03	HI-STAR	0.9362	0.9318	0.0008	0.2632
15x15B04	HI-STAR	0.9370	0.9327	0.0008	0.2612
15x15B05	HI-STAR	0.9356	0.9313	0.0008	0.2606
15x15B06	HI-STAR	0.9366	0.9324	0.0007	0.2638
B15x15B01	HI-TRAC	0.9387	0.9344	0.0008	0.2616
B15x15B01	HI-STAR	0.9388	0.9343	0.0009	0.2626
15x15C01	HI-STAR	0.9255	0.9213	0.0007	0.2493
15x15C02	HI-STAR	0.9297	0.9255	0.0007	0.2457
15x15C03	HI-STAR	0.9297	0.9255	0.0007	0.2440
15x15C04	HI-STAR	0.9311	0.9268	0.0008	0.2435
B15x15C01	HI-TRAC	0.9362	0.9319	0.0008	0.2374
B15x15C01	HI-STAR	0.9361	0.9316	0.0009	0.2385

HOLTEC INTERNATIONAL COPYRIGHTED MATERIAL

HI-STORM FSAR
 REPORT HI-2002444

Appendix 6:C-2

Rev. 11

Table 6.C.1 (continued)
 CALCULATIONAL SUMMARY FOR ALL CANDIDATE FUEL TYPES
 AND BASKET CONFIGURATIONS

MPC-24					
Fuel Assembly Designation	Cask	Maximum k_{eff}	Calculated k_{eff}	Std. Dev. (1-sigma)	EALF (eV)
15x15D01	HI-STAR	0.9341	0.9298	0.0008	0.2822
15x15D02	HI-STAR	0.9367	0.9324	0.0008	0.2802
15x15D03	HI-STAR	0.9354	0.9311	0.0008	0.2844
15x15D04	HI-TRAC	0.9354	0.9309	0.0009	0.2963
15x15D04	HI-STAR	0.9339	0.9292	0.0010	0.2958
15x15E01	HI-TRAC	0.9392	0.9349	0.0008	0.2827
15x15E01	HI-STAR	0.9368	0.9325	0.0008	0.2826
15x15F01	HI-STORM	0.3648	0.3614	0.0003	3.03E+04
15x15F01	HI-TRAC	0.9393	0.9347	0.0009	0.2925
15x15F01	HI-STAR	0.9395	0.9350	0.0009	0.2903
15x15G01	HI-TRAC	0.8878	0.8836	0.0007	0.3347
15x15G01	HI-STAR	0.8876	0.8833	0.0008	0.3357
15x15H01	HI-TRAC	0.9333	0.9288	0.0009	0.2353
15x15H01	HI-STAR	0.9337	0.9292	0.0009	0.2349
16x16A01	HI-STAR	0.9287	0.9244	0.0008	0.2704
16x16A02	HI-STAR	0.9263	0.9221	0.0007	0.2702
16x16A03	HI-STORM	0.3588	0.3555	0.0003	2.11E+04
16x16A03	HI-TRAC	0.9322	0.9278	0.0008	0.2673
16x16A03	HI-STAR	0.9327	0.9282	0.0009	0.2661
17x17A01	HI-STORM	0.3243	0.3210	0.0003	3.23E+04

HOLTEC INTERNATIONAL COPYRIGHTED MATERIAL

HI-STORM FSAR
 REPORT HI-2002444

Appendix 6.C-3

Rev. 11

Table 6.C.1 (continued)
 CALCULATIONAL SUMMARY FOR ALL CANDIDATE FUEL TYPES
 AND BASKET CONFIGURATIONS

MPC-24					
Fuel Assembly Designation	Cask	Maximum k_{eff}	Calculated k_{eff}	Std. Dev. (1-sigma)	EALF (eV)
17x17A01	HI-TRAC	0.9378	0.9335	0.0008	0.2133
17x17A01	HI-STAR	0.9368	0.9325	0.0008	0.2131
17x17A02	HI-STAR	0.9329	0.9286	0.0008	0.2018
17x17B01	HI-STAR	0.9288	0.9243	0.0009	0.2607
17x17B02	HI-STAR	0.9290	0.9247	0.0008	0.2596
17x17B03	HI-STAR	0.9243	0.9199	0.0008	0.2625
17x17B04	HI-STAR	0.9324	0.9279	0.0009	0.2576
17x17B05	HI-STAR	0.9266	0.9222	0.0008	0.2539
17x17B06	HI-TRAC	0.9318	0.9275	0.0008	0.2570
17x17B06	HI-STAR	0.9311	0.9268	0.0008	0.2593
17x17C01	HI-STAR	0.9293	0.9250	0.0008	0.2595
17x17C02	HI-TRAC	0.9319	0.9274	0.0009	0.2610
17x17C02	HI-STAR	0.9336	0.9293	0.0008	0.2624

HOLTEC INTERNATIONAL COPYRIGHTED MATERIAL

HI-STORM FSAR
 REPORT HI-2002444

Appendix 6.C-4

Rev. 11

Table 6.C.1 (continued)
 CALCULATIONAL SUMMARY FOR ALL CANDIDATE FUEL TYPES
 AND BASKET CONFIGURATIONS

MPC-68					
Fuel Assembly Designation	Cask	Maximum k_{eff}	Calculated k_{eff}	Std. Dev. (1-sigma)	EALF (eV)
6x6A01	HI-STAR	0.7539	0.7498	0.0007	0.2754
6x6A02	HI-STAR	0.7517	0.7476	0.0007	0.2510
6x6A03	HI-STAR	0.7545	0.7501	0.0008	0.2494
6x6A04	HI-STAR	0.7537	0.7494	0.0008	0.2494
6x6A05	HI-STAR	0.7555	0.7512	0.0008	0.2470
6x6A06	HI-STAR	0.7618	0.7576	0.0008	0.2298
6x6A07	HI-STAR	0.7588	0.7550	0.0005	0.2360
6x6A08	HI-STAR	0.7808	0.7766	0.0007	0.2527
B6x6A01	HI-TRAC	0.7732	0.7691	0.0007	0.2458
B6x6A01	HI-STAR	0.7727	0.7685	0.0007	0.2460
B6x6A02	HI-TRAC	0.7785	0.7741	0.0008	0.2411
B6x6A02	HI-STAR	0.7782	0.7738	0.0008	0.2408
B6x6A03	HI-TRAC	0.7886	0.7846	0.0007	0.2311
B6x6A03	HI-STAR	0.7888	0.7846	0.0007	0.2310
6x6B01	HI-STAR	0.7604	0.7563	0.0007	0.2461
6x6B02	HI-STAR	0.7618	0.7577	0.0007	0.2450
6x6B03	HI-STAR	0.7619	0.7578	0.0007	0.2439
6x6B04	HI-STAR	0.7686	0.7644	0.0008	0.2286
6x6B05	HI-STAR	0.7824	0.7785	0.0006	0.2184
B6x6B01	HI-TRAC	0.7833	0.7794	0.0006	0.2181
B6x6B01	HI-STAR	0.7822	0.7783	0.0006	0.2190
6x6C01	HI-STORM	0.2759	0.2726	0.0003	1.59E+04

HOLTEC INTERNATIONAL COPYRIGHTED MATERIAL

HI-STORM FSAR
 REPORT HI-2002444

Appendix 6.C-5

Rev. 11

Table 6.C.1 (continued)
 CALCULATIONAL SUMMARY FOR ALL CANDIDATE FUEL TYPES
 AND BASKET CONFIGURATIONS

MPC-68					
Fuel Assembly Designation	Cask	Maximum k_{eff}	Calculated k_{eff}	Std. Dev. (1-sigma)	EALF (eV)
6x6C01	HI-TRAC	0.8024	0.7982	0.0008	0.2135
6x6C01	HI-STAR	0.8021	0.7980	0.0007	0.2139
7x7A01	HI-TRAC	0.7963	0.7922	0.0007	0.2016
7x7A01	HI-STAR	0.7974	0.7932	0.0008	0.2015
7x7B01	HI-STAR	0.9372	0.9330	0.0007	0.3658
7x7B02	HI-STAR	0.9301	0.9260	0.0007	0.3524
7x7B03	HI-STAR	0.9313	0.9271	0.0008	0.3438
7x7B04	HI-STAR	0.9311	0.9270	0.0007	0.3816
7x7B05	HI-STAR	0.9350	0.9306	0.0008	0.3382
7x7B06	HI-STAR	0.9298	0.9260	0.0006	0.3957
B7x7B01	HI-TRAC	0.9367	0.9324	0.0008	0.3899
B7x7B01	HI-STAR	0.9375	0.9332	0.0008	0.3887
B7x7B02	HI-STORM	0.4061	0.4027	0.0003	2.069E+04
B7x7B02	HI-TRAC	0.9385	0.9342	0.0008	0.3952
B7x7B02	HI-STAR	0.9386	0.9344	0.0007	0.3983
8x8A01	HI-TRAC	0.7662	0.7620	0.0008	0.2250
8x8A01	HI-STAR	0.7685	0.7644	0.0007	0.2227
8x8A02	HI-TRAC	0.7690	0.7650	0.0007	0.2163
8x8A02	HI-STAR	0.7697	0.7656	0.0007	0.2158
8x8B01	HI-STAR	0.9310	0.9265	0.0009	0.2935
8x8B02	HI-STAR	0.9227	0.9185	0.0007	0.2993
8x8B03	HI-STAR	0.9299	0.9257	0.0008	0.3319

HOLTEC INTERNATIONAL COPYRIGHTED MATERIAL

HI-STORM FSAR
 REPORT HI-2002444

Appendix 6.C-6

Rev. 11

Table 6.C.1 (continued)
 CALCULATIONAL SUMMARY FOR ALL CANDIDATE FUEL TYPES
 AND BASKET CONFIGURATIONS

MPC-68					
Fuel Assembly Designation	Cask	Maximum k_{eff}	Calculated k_{eff}	Std. Dev. (1-sigma)	EALF (eV)
8x8B04	HI-STAR	0.9236	0.9194	0.0008	0.3700
B8x8B01	HI-TRAC	0.9352	0.9310	0.0008	0.3393
B8x8B01	HI-STAR	0.9346	0.9301	0.0009	0.3389
B8x8B02	HI-TRAC	0.9401	0.9359	0.0007	0.3331
B8x8B02	HI-STAR	0.9385	0.9343	0.0008	0.3329
B8x8B03	HI-STORM	0.3934	0.3900	0.0004	1.815E+04
B8x8B03	HI-TRAC	0.9427	0.9385	0.0008	0.3278
B8x8B03	HI-STAR	0.9416	0.9375	0.0007	0.3293
8x8C01	HI-STAR	0.9315	0.9273	0.0007	0.2822
8x8C02	HI-STAR	0.9313	0.9268	0.0009	0.2716
8x8C03	HI-STAR	0.9329	0.9286	0.0008	0.2877
8x8C04	HI-STAR	0.9348	0.9307	0.0007	0.2915
8x8C05	HI-STAR	0.9353	0.9312	0.0007	0.2971
8x8C06	HI-STAR	0.9353	0.9312	0.0007	0.2944
8x8C07	HI-STAR	0.9314	0.9273	0.0007	0.2972
8x8C08	HI-STAR	0.9339	0.9298	0.0007	0.2915
8x8C09	HI-STAR	0.9301	0.9260	0.0007	0.3183
8x8C10	HI-STAR	0.9317	0.9275	0.0008	0.3018
8x8C11	HI-STAR	0.9328	0.9287	0.0007	0.3001
8x8C12	HI-STAR	0.9285	0.9242	0.0008	0.3062
B8x8C01	HI-TRAC	0.9348	0.9305	0.0008	0.3114
B8x8C01	HI-STAR	0.9357	0.9313	0.0009	0.3141

HOLTEC INTERNATIONAL COPYRIGHTED MATERIAL

HI-STORM FSAR
 REPORT HI-2002444

Appendix 6.C-7

Rev. 11

Table 6.C.1 (continued)
 CALCULATIONAL SUMMARY FOR ALL CANDIDATE FUEL TYPES
 AND BASKET CONFIGURATIONS

MPC-68					
Fuel Assembly Designation	Cask	Maximum k_{eff}	Calculated k_{eff}	Std. Dev. (1-sigma)	EALF (eV)
B8x8C02	HI-STORM	0.3714	0.3679	0.0004	2.30E+04
B8x8C02	HI-TRAC	0.9402	0.9360	0.0008	0.3072
B8x8C02	HI-STAR	0.9425	0.9384	0.0007	0.3081
B8x8C03	HI-TRAC	0.9429	0.9386	0.0008	0.3045
B8x8C03	HI-STAR	0.9418	0.9375	0.0008	0.3056
8x8D01	HI-STAR	0.9342	0.9302	0.0006	0.2733
8x8D02	HI-STAR	0.9325	0.9284	0.0007	0.2750
8x8D03	HI-STAR	0.9351	0.9309	0.0008	0.2731
8x8D04	HI-STAR	0.9338	0.9296	0.0007	0.2727
8x8D05	HI-STAR	0.9339	0.9294	0.0009	0.2700
8x8D06	HI-STAR	0.9365	0.9324	0.0007	0.2777
8x8D07	HI-STAR	0.9341	0.9297	0.0009	0.2694
8x8D08	HI-STAR	0.9376	0.9332	0.0009	0.2841
B8x8D01	HI-TRAC	0.9408	0.9368	0.0006	0.2773
B8x8D01	HI-STAR	0.9403	0.9363	0.0007	0.2778
8x8E01	HI-TRAC	0.9309	0.9266	0.0008	0.2834
8x8E01	HI-STAR	0.9312	0.9270	0.0008	0.2831
8x8F01	HI-TRAC	0.9396	0.9356	0.0006	0.2255
8x8F01	HI-STAR	0.9411	0.9366	0.0009	0.2264
9x9A01	HI-STAR	0.9353	0.9310	0.0008	0.2875
9x9A02	HI-STAR	0.9388	0.9345	0.0008	0.2228
9x9A03	HI-STAR	0.9351	0.9310	0.0007	0.2837

HOLTEC INTERNATIONAL COPYRIGHTED MATERIAL

HI-STORM FSAR
 REPORT HI-2002444

Appendix 6.C-8

Rev. 11

Table 6.C.1 (continued)
 CALCULATIONAL SUMMARY FOR ALL CANDIDATE FUEL TYPES
 AND BASKET CONFIGURATIONS

MPC-68					
Fuel Assembly Designation	Cask	Maximum k_{eff}	Calculated k_{eff}	Std. Dev. (1-sigma)	EALF (eV)
9x9A04	HI-STAR	0.9396	0.9355	0.0007	0.2262
B9x9A01	HI-STORM	0.3365	0.3331	0.0003	1.78E+04
B9x9A01	HI-TRAC	0.9434	0.9392	0.0007	0.2232
B9x9A01	HI-STAR	0.9417	0.9374	0.0008	0.2236
9x9B01	HI-STAR	0.9380	0.9336	0.0008	0.2576
9x9B02	HI-STAR	0.9373	0.9329	0.0009	0.2578
9x9B03	HI-STAR	0.9417	0.9374	0.0008	0.2545
B9x9B01	HI-TRAC	0.9417	0.9376	0.0007	0.2504
B9x9B01	HI-STAR	0.9436	0.9394	0.0008	0.2506
9x9C01	HI-TRAC	0.9377	0.9335	0.0008	0.2697
9x9C01	HI-STAR	0.9395	0.9352	0.0008	0.2698
9x9D01	HI-TRAC	0.9387	0.9343	0.0008	0.2635
9x9D01	HI-STAR	0.9394	0.9350	0.0009	0.2625
9x9E01	HI-STAR	0.9334	0.9293	0.0007	0.2227
9x9E02	HI-STORM	0.3676	0.3642	0.0003	2.409E+04
9x9E02	HI-TRAC	0.9402	0.9360	0.0008	0.2075
9x9E02	HI-STAR	0.9401	0.9359	0.0008	0.2065
9x9F01	HI-STAR	0.9307	0.9265	0.0007	0.2899
9x9F02	HI-STORM	0.3676	0.3642	0.0003	2.409E+04
9x9F02	HI-TRAC	0.9402	0.9360	0.0008	0.2075
9x9F02	HI-STAR	0.9401	0.9359	0.0008	0.2065
9x9G01	HI-TRAC	0.9307	0.9265	0.0007	0.2193

HOLTEC INTERNATIONAL COPYRIGHTED MATERIAL

HI-STORM FSAR
 REPORT HI-2002444

Appendix 6.C-9

Rev. 11

Table 6.C.1 (continued)
 CALCULATIONAL SUMMARY FOR ALL CANDIDATE FUEL TYPES
 AND BASKET CONFIGURATIONS

MPC-68					
Fuel Assembly Designation	Cask	Maximum k_{eff}	Calculated k_{eff}	Std. Dev. (1-sigma)	EALF (eV)
9x9G01	HI-STAR	0.9309	0.9265	0.0008	0.2191
10x10A01	HI-STAR	0.9377	0.9335	0.0008	0.3170
10x10A02	HI-STAR	0.9426	0.9386	0.0007	0.2159
10x10A03	HI-STAR	0.9396	0.9356	0.0007	0.3169
B10x10A01	HI-STORM	0.3379	0.3345	0.0003	1.74E+04
B10x10A01	HI-TRAC	0.9448	0.9405	0.0008	0.2214
B10x10A01	HI-STAR	0.9457	0.9414	0.0008	0.2212
10x10B01	HI-STAR	0.9384	0.9341	0.0008	0.2881
10x10B02	HI-STAR	0.9416	0.9373	0.0008	0.2333
10x10B03	HI-STAR	0.9375	0.9334	0.0007	0.2856
B10x10B01	HI-TRAC	0.9443	0.9401	0.0007	0.2380
B10x10B01	HI-STAR	0.9436	0.9395	0.0007	0.2366
10x10C01	HI-TRAC	0.9430	0.9387	0.0008	0.2424
10x10C01	HI-STAR	0.9433	0.9392	0.0007	0.2416
10x10D01	HI-TRAC	0.9383	0.9343	0.0007	0.3359
10x10D01	HI-STAR	0.9376	0.9333	0.0008	0.3355
10x10E01	HI-TRAC	0.9157	0.9116	0.0007	0.3301
10x10E01	HI-STAR	0.9185	0.9144	0.0007	0.2936

HOLTEC INTERNATIONAL COPYRIGHTED MATERIAL

HI-STORM FSAR
 REPORT HI-2002444

Appendix 6.C-10

Rev. 11

Table 6.C.1 (continued)
 CALCULATIONAL SUMMARY FOR ALL CANDIDATE FUEL TYPES
 AND BASKET CONFIGURATIONS

MPC-24 400PPM SOLUBLE BORON					
Fuel Assembly Designation	Cask	Maximum k_{eff}	Calculated k_{eff}	Std. Dev. (1-sigma)	EALF (eV)
14x14A03	HI-STAR	0.8884	0.8841	0.0008	0.2501
B14x14B01	HI-STAR	0.8900	0.8855	0.0009	0.3173
14x14C03	HI-STAR	0.8950	0.8907	0.0008	0.3410
14x14D01	HI-STAR	0.8518	0.8475	0.0008	0.4395
14x14E02	HI-STAR	0.7132	0.7090	0.0007	0.4377
15x15A01	HI-STAR	0.9119	0.9076	0.0008	0.3363
B15x15B01	HI-STAR	0.9284	0.9241	0.0008	0.3398
B15x15C01	HI-STAR	0.9236	0.9193	0.0008	0.3074
15x15D04	HI-STAR	0.9261	0.9218	0.0008	0.3841
15x15E01	HI-STAR	0.9265	0.9221	0.0008	0.3656
15x15F01	HI-STORM (DRY)	0.4013	0.3978	0.0004	28685
15x15F01	HI-TRAC	0.9301	0.9256	0.0009	0.3790
15x15F01	HI-STAR	0.9314	0.9271	0.0008	0.3791
15x15G01	HI-STAR	0.8939	0.8897	0.0007	0.4392
15x15H01	HI-TRAC	0.9345	0.9301	0.0008	0.3183
15x15H01	HI-STAR	0.9366	0.9320	0.0009	0.3175
16x16A03	HI-STAR	0.8993	0.8948	0.0009	0.3164
17x17A01	HI-STAR	0.9264	0.9221	0.0008	0.2801
17x17B06	HI-STAR	0.9284	0.9241	0.0008	0.3383
17x17C02	HI-TRAC	0.9296	0.9250	0.0009	0.3447
17x17C02	HI-STAR	0.9294	0.9249	0.0009	0.3433

HOLTEC INTERNATIONAL COPYRIGHTED MATERIAL

HI-STORM FSAR
 REPORT HI-2002444

Appendix 6.C-11

Rev. 11

Table 6.C.1 (continued)
 CALCULATIONAL SUMMARY FOR ALL CANDIDATE FUEL TYPES
 AND BASKET CONFIGURATIONS

MPC-24E, UNBORATED WATER					
Fuel Assembly Designation	Cask	Maximum k_{eff}	Calculated k_{eff}	Std. Dev. (1-sigma)	EALF (eV)
14x14A03	HI-STAR	0.9380	0.9337	0.0008	0.2277
B14x14B01	HI-STAR	0.9312	0.9269	0.0008	0.2927
14x14C01	HI-STAR	0.9356	0.9311	0.0009	0.3161
14x14D01	HI-STAR	0.8875	0.8830	0.0009	0.4026
14x14E02	HI-STAR	0.7651	0.7610	0.0007	0.3645
15x15A01	HI-STAR	0.9336	0.9292	0.0008	0.2879
B15x15B01	HI-STAR	0.9465	0.9421	0.0008	0.2924
B15x15C01	HI-STAR	0.9462	0.9419	0.0008	0.2631
15x15D04	HI-STAR	0.9440	0.9395	0.0009	0.3316
15x15E01	HI-STAR	0.9455	0.9411	0.0009	0.3178
15x15F01	HI-STORM (DRY)	0.3699	0.3665	0.0004	3.280e+04
15x15F01	HI-TRAC	0.9465	0.9421	0.0009	0.3297
15x15F01	HI-STAR	0.9468	0.9424	0.0008	0.3270
15x15G01	HI-STAR	0.9054	0.9012	0.0007	0.3781
15x15H01	HI-STAR	0.9423	0.9381	0.0008	0.2628
16x16A03	HI-STAR	0.9394	0.9351	0.0008	NC
17x17A01	HI-TRAC	0.9467	0.9425	0.0008	0.2372
17x17A01	HI-STAR	0.9447	0.9406	0.0007	0.2374
17x17B06	HI-STAR	0.9421	0.9377	0.0008	0.2888
17x17C02	HI-STAR	0.9433	0.9390	0.0008	0.2932

HOLTEC INTERNATIONAL COPYRIGHTED MATERIAL

HI-STORM FSAR
 REPORT HI-2002444

Appendix 6.C-12

Rev. 11

Table 6.C.1 (continued)
 CALCULATIONAL SUMMARY FOR ALL CANDIDATE FUEL TYPES
 AND BASKET CONFIGURATIONS

MPC-24E, 300PPM BORATED WATER					
Fuel Assembly Designation	Cask	Maximum k_{eff}	Calculated k_{eff}	Std. Dev. (1-sigma)	EALF (eV)
14x14A03	HI-STAR	0.8963	0.8921	0.0008	0.2231
B14x14B01	HI-STAR	0.8974	0.8931	0.0008	0.3214
14x14C01	HI-STAR	0.9031	0.8988	0.0008	0.3445
14x14D01	HI-STAR	0.8588	0.8546	0.0007	0.4407
14x14E02	HI-STAR	0.7249	0.7205	0.0008	0.4186
15x15A01	HI-STAR	0.9161	0.9118	0.0008	0.3408
B15x15B01	HI-STAR	0.9321	0.9278	0.0008	0.3447
B15x15C01	HI-STAR	0.9271	0.9227	0.0008	0.3121
15x15D04	HI-STAR	0.9290	0.9246	0.0009	0.3950
15x15E01	HI-STAR	0.9309	0.9265	0.0009	0.3754
15x15F01	HI-STORM (DRY)	0.3897	0.3863	0.0003	3.192E+04
15x15F01	HI-TRAC	0.9333	0.9290	0.0008	0.3900
15x15F01	HI-STAR	0.9332	0.9289	0.0008	0.3861
15x15G01	HI-STAR	0.8972	0.8930	0.0007	0.4473
15x15H01	HI-TRAC	0.9399	0.9356	0.0008	0.3235
15x15H01	HI-STAR	0.9399	0.9357	0.0008	0.3248
16x16A03	HI-STAR	0.9060	0.9017	0.0008	NC
17x17A01	HI-STAR	0.9332	0.9287	0.0009	0.2821
17x17B06	HI-STAR	0.9316	0.9273	0.0008	0.3455
17x17C02	HI-TRAC	0.9320	0.9277	0.0008	0.2819
17x17C02	HI-STAR	0.9312	0.9270	0.0007	0.3530

HOLTEC INTERNATIONAL COPYRIGHTED MATERIAL

HI-STORM FSAR
 REPORT HI-2002444

Appendix 6.C-13

Rev. 11

Table 6.C.1 (continued)
 CALCULATIONAL SUMMARY FOR ALL CANDIDATE FUEL TYPES
 AND BASKET CONFIGURATIONS

MPC-32, 4.1% Enrichment, Bounding Cases					
Fuel Assembly Designation	Cask	Maximum k_{eff}	Calculated k_{eff}	Std. Dev. (1-sigma)	EALF (eV)
14x14A03	HI-STAR	0.9041	0.9001	0.0006	0.3185
B14x14B01	HI-STAR	0.9257	0.9216	0.0007	0.4049
14x14C01	HI-STAR	0.9423	0.9382	0.0007	0.4862
14x14D01	HI-STAR	0.8970	0.8931	0.0006	0.5474
14x14E02	HI-STAR	0.7340	0.7300	0.0006	0.6817
15x15A01	HI-STAR	0.9206	0.9167	0.0006	0.5072
B15x15B01	HI-STAR	0.9397	0.9358	0.0006	0.4566
B15x15C01	HI-STAR	0.9266	0.9227	0.0006	0.4167
15x15D04	HI-STAR	0.9384	0.9345	0.0006	0.5594
15x15E01	HI-STAR	0.9365	0.9326	0.0006	0.5403
15x15F01	HI-STORM (DRY)	0.4691	0.4658	0.0003	1.207E+04
15x15F01	HI-TRAC	0.9403	0.9364	0.0006	0.4938
15x15F01	HI-STAR	0.9411	0.9371	0.0006	0.4923
15x15G01	HI-STAR	0.9147	0.9108	0.0006	0.5880
15x15H01	HI-STAR	0.9276	0.9237	0.0006	0.4710
15x15I01	HI-STAR	0.9340	0.9301	0.0006	0.5488
16x16A03	HI-STAR	0.9375	0.9333	0.0007	0.4488
17x17A01	HI-STAR	0.9111	0.9072	0.0006	0.4055
17x17B06	HI-STAR	0.9309	0.9269	0.0006	0.4365
17x17C02	HI-TRAC	0.9365	0.9327	0.0006	0.4468
17x17C02	HI-STAR	0.9355	0.9317	0.0006	0.4469

HOLTEC INTERNATIONAL COPYRIGHTED MATERIAL

HI-STORM FSAR
 REPORT HI-2002444

Appendix 6.C-14

Rev. 11

Table 6.C.1 (continued)
 CALCULATIONAL SUMMARY FOR ALL CANDIDATE FUEL TYPES
 AND BASKET CONFIGURATIONS

MPC-32, 5.0% Enrichment, Bounding Cases					
Fuel Assembly Designation	Cask	Maximum k_{eff}	Calculated k_{eff}	Std. Dev. (1-sigma)	EALF (eV)
14x14A03	HI-STAR	0.9000	0.8959	0.0007	0.4651
B14x14B01	HI-STAR	0.9214	0.9175	0.0006	0.6009
14x14C01	HI-STAR	0.9480	0.9440	0.0006	0.6431
14x14D01	HI-STAR	0.9050	0.9009	0.0007	0.7276
14x14E02	HI-STAR	0.7415	0.7375	0.0006	0.9226
15x15A01	HI-STAR	0.9230	0.9189	0.0007	0.7143
B15x15B01	HI-STAR	0.9429	0.9390	0.0006	0.7234
B15x15C01	HI-STAR	0.9307	0.9268	0.0006	0.6439
15x15D04	HI-STAR	0.9466	0.9425	0.0007	0.7525
15x15E01	HI-STAR	0.9434	0.9394	0.0007	0.7215
15x15F01	HI-STORM (DRY)	0.5142	0.5108	0.0004	1.228E+04
15x15F01	HI-TRAC	0.9470	0.9431	0.0006	0.7456
15x15F01	HI-STAR	0.9483	0.9443	0.0007	0.7426
15x15G01	HI-STAR	0.9251	0.9212	0.0006	0.9303
15x15H01	HI-STAR	0.9333	0.9292	0.0007	0.7015
15x15I01	HI-STAR	0.9402	0.9359	0.0008	0.7318
16x16A03	HI-STAR	0.9429	0.9388	0.0007	0.5920
17x17A01	HI-STAR	0.9161	0.9122	0.0006	0.6141
17x17B06	HI-STAR	0.9371	0.9331	0.0006	0.6705
17x17C02	HI-TRAC	0.9436	0.9396	0.0006	0.6773
17x17C02	HI-STAR	0.9437	0.9399	0.0006	0.6780

HOLTEC INTERNATIONAL COPYRIGHTED MATERIAL

HI-STORM FSAR
 REPORT HI-2002444

Appendix 6.C-15

Rev. 11

Table 6.C.1 (continued)
CALCULATIONAL SUMMARY FOR ALL CANDIDATE FUEL TYPES
AND BASKET CONFIGURATIONS

Note: Maximum $k_{\text{eff}} = \text{Calculated } k_{\text{eff}} + K_c \times \sigma_c + \text{Bias} + \sigma_B$

where:

$$K_c = 2.0$$

$$\sigma_c = \text{Std. Dev. (1-sigma)}$$

$$\text{Bias} = 0.0021$$

$$\sigma_B = 0.0006$$

See Subsection 6.4.3 for further explanation.

HOLTEC INTERNATIONAL COPYRIGHTED MATERIAL

HI-STORM FSAR
REPORT HI-2002444

Appendix 6.C-16

Rev. 11

APPENDIX 6.D: SAMPLE INPUT FILES

(Total number of pages in this appendix : 35)

File Description	Starting Page
MCNP4a input file for MPC-24 in HI-TRAC	Appendix 6.D-2
MCNP4a input file for MPC-68 in HI-TRAC	Appendix 6.D-13
MCNP4a input file for MPC-24 in HI-STORM	Appendix 6.D-19
MCNP4a input file for MPC-68 in HI-STORM	Appendix 6.D-30

HOLTEC INTERNATIONAL COPYRIGHTED MATERIAL

HI-STORM FSAR
REPORT HI-2002444

Appendix 6.D-1

Rev. 1

```

HI-TRAC Transfer Cask containing MPC24, 17x17 assembly @ 4.0 wt% Enrich.
c
c
c
c MPC-24/24E cell configuration
c
c HI-TRAC with active length 150 inch
c
c Cask Input Preprocessor
c cskinp 17a 17a mpc24n mpc24n hitrac tracr150 4.0 4tf7a45 pure
c ----- cpp\17a.bat
c   added 17a.ce
c   added 17a.su
c   added 17a.sp
c ----- cpp\mpc24n.bat
c   added mpc24n.co
c   added mpc24n.ce
c   added mpc24n.su
c   added mpc24n.sp
c ----- cpp\hitrac.bat
c   added tracr150.co
c   added hitrac.ce
c   added tracr150.su
c   added tracr150.sp
c end of comments
c
c start of cells
c
c 17x17a
c
c number of cells: 6
c cell numbers:      1 to 7
c univers numbers:  1 to 3
c surface numbers:  1 to 9
c
c number of cells: 1
1   1 -10.522   -1 u=2      $ fuel
2   4 -1.0     1 -2 u=2      $ gap
3   3 -6.55    2 -3 u=2      $ Zr Clad
4   4 -1.0     3 u=2        $ water in fuel region
5   4 -1.0   -4:5   u=3      $ water in guide tubes
6   3 -6.55    4 -5   u=3      $ guide tubes
7   4 -1.0   -6   +7   -8   +9   u=1 lat=1
fill= -9:9   -9:9   0:0
1 1 1 1 1 1 1 1 1 1 1 1 1 1 1 1 1 1 1 1 1 1 1 1 1 1 1 1 1 1 1 1
1 2 2 2 2 2 2 2 2 2 2 2 2 2 2 2 2 2 2 2 2 2 2 2 2 2 2 2 2 2 2 2 1
1 2 2 2 2 2 2 2 2 2 2 2 2 2 2 2 2 2 2 2 2 2 2 2 2 2 2 2 2 2 2 2 1
1 2 2 2 2 2 3 2 2 3 2 2 3 2 2 3 2 2 3 2 2 3 2 2 3 2 2 3 2 2 3 2 2 1
1 2 2 2 3 2 2 2 2 2 2 2 2 2 2 2 2 2 2 2 2 2 2 2 2 2 3 2 2 2 2 1
1 2 2 2 2 2 2 2 2 2 2 2 2 2 2 2 2 2 2 2 2 2 2 2 2 2 2 2 2 2 2 2 1
1 2 2 3 2 2 3 2 2 3 2 2 3 2 2 3 2 2 3 2 2 3 2 2 3 2 2 3 2 2 3 2 2 1
1 2 2 2 2 2 2 2 2 2 2 2 2 2 2 2 2 2 2 2 2 2 2 2 2 2 2 2 2 2 2 2 1
1 2 2 3 2 2 3 2 2 3 2 2 3 2 2 3 2 2 3 2 2 3 2 2 3 2 2 3 2 2 3 2 2 1
1 2 2 2 2 2 2 2 2 2 2 2 2 2 2 2 2 2 2 2 2 2 2 2 2 2 2 2 2 2 2 2 1
1 2 2 2 2 2 3 2 2 3 2 2 3 2 2 3 2 2 3 2 2 3 2 2 3 2 2 3 2 2 3 2 2 1
1 2 2 2 2 2 2 2 2 2 2 2 2 2 2 2 2 2 2 2 2 2 2 2 2 2 2 2 2 2 2 2 1
1 2 2 2 2 2 2 2 2 2 2 2 2 2 2 2 2 2 2 2 2 2 2 2 2 2 2 2 2 2 2 2 1
1 2 2 2 2 2 2 2 2 2 2 2 2 2 2 2 2 2 2 2 2 2 2 2 2 2 2 2 2 2 2 2 1

```

HOLTEC INTERNATIONAL COPYRIGHTED MATERIAL

HI-STORM FSAR

Rev. 1

REPORT HI-2002444

Appendix 6.D-2

```

1 1 1 1 1 1 1 1 1 1 1 1 1 1 1 1 1
c
c MPC-24
c
c number of cells: 102
c cell numbers : 400 to 699
c universe numbers : 4 to 9
c surface numbers : 400 to 699
c
c Right Side
c
408 0 -410 411 -412 413 u=4 fill=1 (1)
409 5 -7.84 410 -424 413 -426 u=4
410 4 -1.0 424 -428 448 -445 u=4
411 7 -2.7 428 -528 448 -445 u=4
412 6 -2.66 528 -532 448 -445 u=4
413 7 -2.7 532 -432 448 -445 u=4
414 4 -1.0 432 -436 448 -445 u=4
415 5 -7.84 436 -440 448 -445 u=4
416 4 -1.0 440 413 u=4
417 4 -1.0 424 -440 413 -447 u=4
418 4 -1.0 424 -440 446 u=4
419 5 -7.84 424 -440 447 -448 u=4
420 5 -7.84 424 -440 445 -446 u=4
c
c Left Side
c
421 5 -7.84 425 -411 413 u=4
422 4 -1.0 429 -425 448 -445 u=4
423 7 -2.7 529 -429 448 -445 u=4
424 6 -2.66 533 -529 448 -445 u=4
425 7 -2.7 433 -533 448 -445 u=4
426 4 -1.0 437 -433 448 -445 u=4
427 5 -7.84 441 -437 448 -445 u=4
428 4 -1.0 -441 413 u=4
429 4 -1.0 441 -425 413 -447 u=4
430 4 -1.0 441 -425 446 u=4
431 5 -7.84 441 -425 447 -448 u=4
432 5 -7.84 441 -425 445 -446 u=4
c
c Top
c
433 5 -7.84 411 -410 412 -426 u=4
434 4 -1.0 451 -452 426 -430 u=4
435 7 -2.7 451 -452 430 -530 u=4
436 6 -2.66 451 -452 530 -534 u=4
437 7 -2.7 451 -452 534 -434 u=4
438 4 -1.0 451 -452 434 -438 u=4
439 5 -7.84 451 -452 438 -442 u=4
440 4 -1.0 411 -424 442 u=4
441 4 -1.0 411 -450 426 -442 u=4
442 4 -1.0 453 -424 426 -442 u=4
443 5 -7.84 450 -451 426 -442 u=4
444 5 -7.84 452 -453 426 -442 u=4
c
c Bottom
c
445 5 -7.84 427 -413 u=4
446 4 -1.0 451 -452 431 -427 u=4
447 7 -2.7 451 -452 531 -431 u=4
448 6 -2.66 451 -452 535 -531 u=4
449 7 -2.7 451 -452 435 -535 u=4

```

HOLTEC INTERNATIONAL COPYRIGHTED MATERIAL

HI-STORM FSAR

Rev. 1

REPORT HI-2002444

Appendix 6.D-3


```

450  4 -1.0      451 -452    439 -435    u=4
451  5 -7.84    451 -452    443 -439    u=4
452  4 -1.0      411          -443    u=4
453  4 -1.0      411 -450    443 -427    u=4
454  4 -1.0      453          443 -427    u=4
455  5 -7.84    450 -451    443 -427    u=4
456  5 -7.84    452 -453    443 -427    u=4
457  5 -7.84    425 -411          -427    u=4
458  4 -1.0          -425        -427    u=4
c
c   TYPE B CELL - Short Boral on top and right
c
c   Right Side
c
459  0          -410  411 -412  413    u=5 fill=1 (1)
460  5 -7.84    410 -424    413 -426    u=5
470  4 -1.0      424 -428    548 -545    u=5
471  7 -2.7      428 -528    548 -545    u=5
472  6 -2.66    528 -532    548 -545    u=5
473  7 -2.7      532 -432    548 -545    u=5
474  4 -1.0      432 -436    548 -545    u=5
475  5 -7.84    436 -440    548 -545    u=5
476  4 -1.0      440          413    u=5
477  4 -1.0      424 -440    413 -547    u=5
478  4 -1.0      424 -440    546    u=5
479  5 -7.84    424 -440    547 -548    u=5
480  5 -7.84    424 -440    545 -546    u=5
c
c   Left Side
c
481  5 -7.84    425 -411    413    u=5
482  4 -1.0      429 -425    448 -445    u=5
483  7 -2.7      529 -429    448 -445    u=5
484  6 -2.66    533 -529    448 -445    u=5
485  7 -2.7      433 -533    448 -445    u=5
486  4 -1.0      437 -433    448 -445    u=5
487  5 -7.84    441 -437    448 -445    u=5
488  4 -1.0          -441    413    u=5
489  4 -1.0      441 -425    413 -447    u=5
490  4 -1.0      441 -425    446    u=5
491  5 -7.84    441 -425    447 -448    u=5
492  5 -7.84    441 -425    445 -446    u=5
c
c   Top
c
493  5 -7.84    411 -410    412 -426    u=5
494  4 -1.0      551 -552    426 -430    u=5
495  7 -2.7      551 -552    430 -530    u=5
496  6 -2.66    551 -552    530 -534    u=5
497  7 -2.7      551 -552    534 -434    u=5
498  4 -1.0      551 -552    434 -438    u=5
499  5 -7.84    551 -552    438 -442    u=5
500  4 -1.0      411 -424    442    u=5
501  4 -1.0      411 -550    426 -442    u=5
502  4 -1.0      553 -424    426 -442    u=5
503  5 -7.84    550 -551    426 -442    u=5
504  5 -7.84    552 -553    426 -442    u=5
c
c   Bottom
c
505  5 -7.84    427          -413    u=5
506  4 -1.0      451 -452    431 -427    u=5

```

HOLTEC INTERNATIONAL COPYRIGHTED MATERIAL

HI-STORM FSAR

Rev. 1

REPORT HI-2002444

Appendix 6.D-4

507	7	-2.7	451	-452	531	-431	u=5
508	6	-2.66	451	-452	535	-531	u=5
509	7	-2.7	451	-452	435	-535	u=5
510	4	-1.0	451	-452	439	-435	u=5
511	5	-7.84	451	-452	443	-439	u=5
512	4	-1.0	411		-443		u=5
513	4	-1.0	411	-450	443	-427	u=5
514	4	-1.0	453		443	-427	u=5
515	5	-7.84	450	-451	443	-427	u=5
516	5	-7.84	452	-453	443	-427	u=5
517	5	-7.84	425	-411		-427	u=5
518	4	-1.0		-425		-427	u=5

c
c
c

TYPE D CELL - Short Boral on left and bottom, different cell ID

c
c number of cells: 51

c
c Right Side

1570	0		-1410	1411	-1412	1413	u=17 fill=1 (1)
1571	5	-7.84	1410	-1424	1413	-1426	u=17
1572	4	-1.0	1424	-1428	1448	-1445	u=17
1573	7	-2.7	1428	-1528	1448	-1445	u=17
1574	6	-2.66	1528	-1532	1448	-1445	u=17
1575	7	-2.7	1532	-1432	1448	-1445	u=17
1576	4	-1.0	1432	-1436	1448	-1445	u=17
1577	5	-7.84	1436	-1440	1448	-1445	u=17
1578	4	-1.0	1440		1413		u=17
1579	4	-1.0	1424	-1440	1413	-1447	u=17
1580	4	-1.0	1424	-1440	1446		u=17
1581	5	-7.84	1424	-1440	1447	-1448	u=17
1582	5	-7.84	1424	-1440	1445	-1446	u=17

c
c Left Side

1583	5	-7.84	1425	-1411	1413		u=17
1584	4	-1.0	1429	-1425	1548	-1545	u=17
1585	7	-2.7	1529	-1429	1548	-1545	u=17
1586	6	-2.66	1533	-1529	1548	-1545	u=17
1587	7	-2.7	1433	-1533	1548	-1545	u=17
1588	4	-1.0	1437	-1433	1548	-1545	u=17
1589	5	-7.84	1441	-1437	1548	-1545	u=17
1590	4	-1.0		-1441	1413		u=17
1591	4	-1.0	1441	-1425	1413	-1547	u=17
1592	4	-1.0	1441	-1425	1546		u=17
1593	5	-7.84	1441	-1425	1547	-1548	u=17
1594	5	-7.84	1441	-1425	1545	-1546	u=17

c
c Top

1595	5	-7.84	1411	-1410	1412	-1426	u=17
1596	4	-1.0	1451	-1452	1426	-1430	u=17
1597	7	-2.7	1451	-1452	1430	-1530	u=17
1598	6	-2.66	1451	-1452	1530	-1534	u=17
1599	7	-2.7	1451	-1452	1534	-1434	u=17
1600	4	-1.0	1451	-1452	1434	-1438	u=17
1601	5	-7.84	1451	-1452	1438	-1442	u=17
1602	4	-1.0	1411	-1424	1442		u=17
1603	4	-1.0	1411	-1450	1426	-1442	u=17
1604	4	-1.0	1453	-1424	1426	-1442	u=17

HOLTEC INTERNATIONAL COPYRIGHTED MATERIAL

HI-STORM FSAR

Rev. 1

REPORT HI-2002444

Appendix 6.D-5

```

1605 5 -7.84 1450 -1451 1426 -1442 u=17
1606 5 -7.84 1452 -1453 1426 -1442 u=17
c
c Bottom
c
1607 5 -7.84 1427 -1413 u=17
1608 4 -1.0 1551 -1552 1431 -1427 u=17
1609 7 -2.7 1551 -1552 1531 -1431 u=17
1610 6 -2.66 1551 -1552 1535 -1531 u=17
1611 7 -2.7 1551 -1552 1435 -1535 u=17
1612 4 -1.0 1551 -1552 1439 -1435 u=17
1613 5 -7.84 1551 -1552 1443 -1439 u=17
1614 4 -1.0 1411 -1443 u=17
1615 4 -1.0 1411 -1550 1443 -1427 u=17
1616 4 -1.0 1553 1443 -1427 u=17
1617 5 -7.84 1550 -1551 1443 -1427 u=17
1618 5 -7.84 1552 -1553 1443 -1427 u=17
1619 5 -7.84 1425 -1411 -1427 u=17
1620 4 -1.0 -1425 -1427 u=17
c
c number of cells: 29
c
c empty cell no boron, no top
c
c
751 4 -1.0 -410 411 -412 413 u=14
752 5 -7.84 410 -424 413 -426 u=14
753 5 -7.84 425 -411 413 u=14
754 4 -1.0 411 -410 412 -426 u=14
755 5 -7.84 427 -413 u=14
756 5 -7.84 425 -411 -427 u=14
757 4 -1.0 411 426 u=14
758 4 -1.0 411 -427 u=14
759 4 -1.0 -425 413 u=14
760 4 -1.0 424 413 -426 u=14
761 4 -1.0 -425 -427 u=14
c
c
701 5 -7.84 701 -702 711 -713 u=9 $ steel post
702 5 -7.84 702 -703 711 -712 u=9 $ steel post
c
711 0 701 -705 711 -715 (702:713) (703:712)
fill=4 (13.8506 13.8506 0) u=9
712 0 704 (-706:-716) (705:715) -717 -710
fill=4 (17.9489 41.5518 0 0 1 0 -1 0 0 0 0 1) u=9
713 0 (705:715) -707 714 (-706:-716) 710
fill=4 (41.5518 17.9489 0 0 -1 0 1 0 0 0 0 1) u=9
714 0 701 -705 717 -719
fill=5 (13.8506 69.253 0) u=9
715 0 707 -709 711 -715
fill=5 (69.253 13.8506 0) u=9
716 0 706 -708 716 -718
fill=17 (45.6501 45.6501 0 -1 0 0 0 -1 0 0 0 1) u=9
717 0 705 -706 717 -719
fill=14 (41.5518 69.253 0) u=9
718 0 707 -709 715 -716
fill=14 (69.253 41.5518 0 0 1 0 1 0 0 0 0 1) u=9
719 0 701 -704 715 -717
fill=14 (-9.75233 41.5518 0 -1 0 0 0 1 0 0 0 1) u=9
720 0 705 -707 711 -714
fill=14 (41.5518 -9.75233 0 0 -1 0 1 0 0 0 0 1) u=9
721 4 -1.0 (706:719) (708:718) (709:716) u=9

```

HOLTEC INTERNATIONAL COPYRIGHTED MATERIAL

HI-STORM FSAR
REPORT HI-2002444

Appendix 6.D-6

Rev. 1

```

c
c
c
731  4 -1.0      720  721  fill=9 (0 0 0) u=19
732  4 -1.0     -720  721  fill=9 (0 0 0
                        -1 0 0 0 1 0 0 0 1) u=19
733  4 -1.0      720 -721  fill=9 (0 0 0
                        1 0 0 0 -1 0 0 0 1) u=19
734  4 -1.0     -720 -721  fill=9 (0 0 0
                        -1 0 0 0 -1 0 0 0 1) u=19
c
673  0           -41           39 -40  fill=19
c
c number of cells: 20
374  4 -1.0      -41           300  -39  $ Water below Fuel (4 in.)
375  5 -7.84     -309           302  -300  $ MPC Steel below Fuel (2.5 in.)
376  5 -7.84     -315           320  -302  $ Transfer Cask Steel (2.0 in.)
377  30 -11.34   -315           321  -320  $ Transfer Cask Lead (2.5 in.)
378  5 -7.84     -315           322  -321  $ Transfer Cask Steel (1.0 in.)
c
379  4 -1.0      -41           40  -301  $ Water above Fuel (6 in.)
380  5 -7.84     -309           301  -303  $ MPC Steel above Fuel (9.5 - 0.06 in)
381  4 -1.0      -309           303  -330  $ Water (1.5 in.)
382  5 -7.84     -315           330  -331  $ Transfer Cask Steel (0.75 in.)
383  31 -1.61    -315           331  -332  $ Transfer Cask Neutron Shield (3.25 in.)
384  5 -7.84     -315           332  -333  $ Transfer Cask Steel (0.5 in.)
c
390  5 -7.84      41 -309  300  -301  $ Radial Steel - MPC shell
391  4 -1.00      309 -310  302  -330  $ Radial Water
392  5 -7.84      310 -311  302  -330  $ Radial Steel - inner shell of Trnsfr Cask
393  30 -11.34    311 -312  302  -330  $ Radial Lead - Transfer Cask lead
394  5 -7.84      312 -313  302  -330  $ Radial Steel - outer shell of Trnsfr Cask
395  4 -1.00      313 -314  302  -330  $ Radial Water - Water Jacket
396  5 -7.84      314 -315  302  -330  $ Radial Steel - outer shell of Water Jacket
c
300  4 -1.00      340 -341 -345  (315 :-322: 333)  $ outer water reflector
301  0           345 :-340: 341  $ outside world
c end of cells
c --- empty line

c --- empty line
c start of surfaces
1    cz          0.3922  $ fuel
2    cz          0.4001  $ clad ID
3    cz          0.4572  $ clad OD
4    cz          0.5613  $ guide ID
5    cz          0.6020  $ guide OD
6    px          0.6299  $ pin pitch
7    px         -0.6299
8    py          0.6299
9    py         -0.6299
c
c
c cell-id        8.98
c cell-pitch     10.906
c wall-thkns     5/16
c angle-thkns    5/16
c boral-gap      0.0035
c boral-gap-o    0.0035
c boral-thkns    0.075
c boral-clad     0.01
c sheathing      0.0235

```

HOLTEC INTERNATIONAL COPYRIGHTED MATERIAL

HI-STORM FSAR
REPORT HI-2002444

Appendix 6.D-7

Rev. 1

c boral-wide 7.5
 c boral-narrow 6.25
 c
 c gap size 1.09
 c basket-od 67.335
 c

410	px	11.40460	\$x 8.98/2	
411	px	-11.40460	\$x {410} *-1	
412	py	11.40460	\$x {410}	
413	py	-11.40460	\$x {411}	
416	px	13.85062	\$x (10.906 + 5/16 - 5/16) /2	
417	px	-13.85062	\$x -10.906 + {416}	
418	py	13.85062	\$x {416}	
419	py	-13.85062	\$x {417}	
424	px	12.19835	\$x {410} + 5/16	\$ angle
425	px	-12.19835	\$x {411} - 5/16	\$ box wall
426	py	12.19835	\$x {412} + 5/16	
427	py	-12.19835	\$x {413} - 5/16	
428	px	12.20724	\$x {424} + 0.0035	\$ wall to boral gap
429	px	-12.20724	\$x {425} - 0.0035	
430	py	12.20724	\$x {426} + 0.0035	
431	py	-12.20724	\$x {427} - 0.0035	
432	px	12.39774	\$x {428} + 0.075	\$ boral
433	px	-12.39774	\$x {429} - 0.075	
434	py	12.39774	\$x {430} + 0.075	
435	py	-12.39774	\$x {431} - 0.075	
436	px	12.40663	\$x {432} + 0.0035	\$ boral to sheathing gap
437	px	-12.40663	\$x {433} - 0.0035	
438	py	12.40663	\$x {434} + 0.0035	
439	py	-12.40663	\$x {435} - 0.0035	
440	px	12.46632	\$x {436} + 0.0235	\$ sheathing
441	px	-12.46632	\$x {437} - 0.0235	
442	py	12.46632	\$x {438} + 0.0235	
443	py	-12.46632	\$x {439} - 0.0235	
445	py	9.52500	\$x 7.5/2	
446	py	9.58469	\$x {445} + 0.0235	\$ sheathing
447	py	-9.58469	\$x {446} *-1	
448	py	-9.52500	\$x {445} *-1	
450	px	-9.58469	\$x {447}	
451	px	-9.52500	\$x {448}	
452	px	9.52500	\$x {445}	
453	px	9.58469	\$x {446}	
528	px	12.23264	\$x {428} + 0.01	\$ Aluminum on the outside of boral
529	px	-12.23264	\$x {429} - 0.01	
530	py	12.23264	\$x {430} + 0.01	
531	py	-12.23264	\$x {431} - 0.01	
532	px	12.37234	\$x {432} - 0.01	
533	px	-12.37234	\$x {433} + 0.01	
534	py	12.37234	\$x {434} - 0.01	
535	py	-12.37234	\$x {435} + 0.01	
545	py	7.93750	\$x 6.25/2	
546	py	7.99719	\$x {545} + 0.0235	\$ sheathing
547	py	-7.99719	\$x {546} *-1	
548	py	-7.93750	\$x {545} *-1	
550	px	-7.99719	\$x {547}	
551	px	-7.93750	\$x {548}	
552	px	7.93750	\$x {545}	
553	px	7.99719	\$x {546}	

c
 c cell-id-2 8.98
 c gap-o 1.09
 c

HOLTEC INTERNATIONAL COPYRIGHTED MATERIAL

HI-STORM FSAR
 REPORT HI-2002444

Appendix 6.D-8

Rev. 1

```

701 px -5.0
702 px 1.90627 $x (10.906 - 8.98)/2 - 5/16 + 0.1
703 px 3.45694 $x 2.722/2
704 px 4.09829 $x 10.906 - 8.98 - 5/16
705 px 27.70124 $x 10.906
706 px 31.79953 $x 2 * 10.906 - (8.98+8.98)/2 - 5/16
707 px 55.40248 $x 2 * 10.906
708 px 59.50077 $x {707} + {704}
709 px 83.10372 $x 3 * 10.906
710 p 1 -1 0 0.1 $ diagonal x=y, offset by 0.1 to avoid intersecting corners
711 py -4.99999 $x {701}
712 py 1.90627 $x {702}
713 py 3.45694 $x {703}
714 py 4.09829 $x {704}
715 py 27.70124 $x {705}
716 py 31.79953 $x {706}
717 py 55.40248 $x {707}
718 py 59.50077 $x {708}
719 py 83.10372 $x {709}
720 px 0.0
721 py 0.0
1410 px 11.40460 $x 8.98/2
1411 px -11.40460 $x {1410} *-1
1412 py 11.40460 $x {1410}
1413 py -11.40460 $x {1411}
1424 px 12.19835 $x {1410} + 5/16 $ angle
1425 px -12.19835 $x {1411} - 5/16 $ box wall
1426 py 12.19835 $x {1412} + 5/16
1427 py -12.19835 $x {1413} - 5/16
1428 px 12.20724 $x {1424} + 0.0035 $ wall to boral gap
1429 px -12.20724 $x {1425} - 0.0035
1430 py 12.20724 $x {1426} + 0.0035
1431 py -12.20724 $x {1427} - 0.0035
1432 px 12.39774 $x {1428} + 0.075 $ boral
1433 px -12.39774 $x {1429} - 0.075
1434 py 12.39774 $x {1430} + 0.075
1435 py -12.39774 $x {1431} - 0.075
1436 px 12.40663 $x {1432} + 0.0035 $ boral to sheathing gap
1437 px -12.40663 $x {1433} - 0.0035
1438 py 12.40663 $x {1434} + 0.0035
1439 py -12.40663 $x {1435} - 0.0035
1440 px 12.46632 $x {1436} + 0.0235 $ sheathing
1441 px -12.46632 $x {1437} - 0.0235
1442 py 12.46632 $x {1438} + 0.0235
1443 py -12.46632 $x {1439} - 0.0235
1445 py 9.52500 $x 7.5/2
1446 py 9.58469 $x {1445} + 0.0235 $ sheathing
1447 py -9.58469 $x {1446} *-1
1448 py -9.52500 $x {1445} *-1
1450 px -9.58469 $x {1447}
1451 px -9.52500 $x {1448}
1452 px 9.52500 $x {1445}
1453 px 9.58469 $x {1446}
1528 px 12.23264 $x {1428} + 0.01 $ Aluminum on the outside of boral
1529 px -12.23264 $x {1429} - 0.01
1530 py 12.23264 $x {1430} + 0.01
1531 py -12.23264 $x {1431} - 0.01
1532 px 12.37234 $x {1432} - 0.01
1533 px -12.37234 $x {1433} + 0.01
1534 py 12.37234 $x {1434} - 0.01
1535 py -12.37234 $x {1435} + 0.01
1545 py 7.93750 $x 6.25/2

```

HOLTEC INTERNATIONAL COPYRIGHTED MATERIAL

HI-STORM FSAR

Rev. 1

REPORT HI-2002444

Appendix 6.D-9

```

1546 py 7.99719 $x {1545} + 0.0235 $ sheathing
1547 py -7.99719 $x {1546} *-1
1548 py -7.93750 $x {1545} *-1
1550 px -7.99719 $x {1547}
1551 px -7.93750 $x {1548}
1552 px 7.93750 $x {1545}
1553 px 7.99719 $x {1546}
39 pz 0.0 $ bottom of active fuel assembly
40 pz 381.0 $ top of active fuel assembly
41 cz 85.57 $ MPC
300 pz -10.16 $ lower water thkness = 4 in.
301 pz 396.24 $ upper water thkness = 6 in.
302 pz -16.51 $ thkness of MPC baseplate = 2.5 in.
303 pz 420.22 $ thkness of MPC lid = 9.5 -0.06 in.
309 cz 86.84 $ I.D. = 68.375 in.
310 cz 87.31 $ I.D. = 68.75 in.
311 cz 89.22 $ I.D. = 70.25 in.
312 cz 100.65 $ I.D. = 79.25 in.
313 cz 103.19 $ I.D. = 81.25 in.
314 cz 116.80 $ I.D. = 91.97 in.
315 cz 118.07 $ I.D. = 92.972 in.
320 pz -21.59 $ thkness steel - 2.0 in.
321 pz -27.94 $ thkness lead - 2.5 in.
322 pz -30.48 $ thkness steel - 1.0 in.
330 pz 424.03 $ thkness water - 1.5 in.
331 pz 425.93 $ thkness steel - 0.75 in.
332 pz 434.19 $ thkness neutron shield - 3.25 in.
333 pz 435.46 $ thkness steel - 0.5 in.
c
*340 pz -60.48 $ lower boundary
*341 pz 465.46 $ upper boundary
*345 cz 148.07 $ outer radial boundary
c end of surfaces
c --- empty line

c --- empty line
tr1 0 0 0
kcode 10000 .94 20 120
dbcn 7j 1e7
sdef par=1 erg=d1 axs=0 0 1 x=d4 y=fx d5 z=d3
c
sp1 -2 1.2895
c
sp3 0 1
c
si4 s 13 14
12 13 14 15
11 12 13 14 15 16
11 12 13 14 15 16
12 13 14 15
13 14

sp4 1 23r
c
ds5 s 26 26
25 25 25 25
24 24 24 24 24 24
23 23 23 23 23 23
22 22 22 22
21 21

c
si11 -79.25435 -57.61355
si12 -51.88077 -30.23997

```

HOLTEC INTERNATIONAL COPYRIGHTED MATERIAL

HI-STORM FSAR
REPORT HI-2002444

Appendix 6.D-10

Rev. 1

```

si13 -24.50719 -2.86639
si14  2.86639  24.50719
si15  30.23997  51.88077
si16  57.61355  79.25435
c
si21 -79.25435 -57.61355
si22 -51.88077 -30.23997
si23 -24.50719 -2.86639
si24  2.86639  24.50719
si25  30.23997  51.88077
si26  57.61355  79.25435
c
sp11  0 1
sp12  0 1
sp13  0 1
sp14  0 1
sp15  0 1
sp16  0 1
sp21  0 1
sp22  0 1
sp23  0 1
sp24  0 1
sp25  0 1
sp26  0 1
c
m3      40000.56c  1.          $ Zr Clad
m4      1001.50c  0.6667         $ Water
        8016.50c  0.3333
m5      24000.50c  0.01761        $ Steel
        25055.50c  0.001761
        26000.55c  0.05977
        28000.50c  0.008239
m6      5010.50c  -0.054427      $ Boral Central Section @ 0.02 g/cmsq
        5011.50c  -0.241373
        13027.50c -0.6222
        6000.50c  -0.0821
m7      13027.50c  1.0
mt4     lwtr.01t
prtmp   j  -120  j  2
fm4     1000  1  -6
f4:n    1
sd4     1000
e4      1.000E-11  1.000E-10  5.000E-10  7.500E-10  1.000E-09  1.200E-09
        1.500E-09  2.000E-09  2.500E-09  3.000E-09
        4.700E-09  5.000E-09  7.500E-09  1.000E-08  2.530E-08
        3.000E-08  4.000E-08  5.000E-08  6.000E-08  7.000E-08
        8.000E-08  9.000E-08  1.000E-07  1.250E-07  1.500E-07
        1.750E-07  2.000E-07  2.250E-07  2.500E-07  2.750E-07
        3.000E-07  3.250E-07  3.500E-07  3.750E-07  4.000E-07
        4.500E-07  5.000E-07  5.500E-07  6.000E-07  6.250E-07
        6.500E-07  7.000E-07  7.500E-07  8.000E-07  8.500E-07
        9.000E-07  9.250E-07  9.500E-07  9.750E-07  1.000E-06
        1.010E-06  1.020E-06  1.030E-06  1.040E-06  1.050E-06
        1.060E-06  1.070E-06  1.080E-06  1.090E-06  1.100E-06
        1.110E-06  1.120E-06  1.130E-06  1.140E-06  1.150E-06
        1.175E-06  1.200E-06  1.225E-06  1.250E-06  1.300E-06
        1.350E-06  1.400E-06  1.450E-06  1.500E-06  1.590E-06
        1.680E-06  1.770E-06  1.860E-06  1.940E-06  2.000E-06
        2.120E-06  2.210E-06  2.300E-06  2.380E-06  2.470E-06
        2.570E-06  2.670E-06  2.770E-06  2.870E-06  2.970E-06
        3.000E-06  3.050E-06  3.150E-06  3.500E-06  3.730E-06
        4.000E-06  4.750E-06  5.000E-06  5.400E-06  6.000E-06

```

HOLTEC INTERNATIONAL COPYRIGHTED MATERIAL

HI-STORM FSAR

Rev. 1

REPORT HI-2002444

Appendix 6.D-11

6.250E-06	6.500E-06	6.750E-06	7.000E-06	7.150E-06
8.100E-06	9.100E-06	1.000E-05	1.150E-05	1.190E-05
1.290E-05	1.375E-05	1.440E-05	1.510E-05	1.600E-05
1.700E-05	1.850E-05	1.900E-05	2.000E-05	2.100E-05
2.250E-05	2.500E-05	2.750E-05	3.000E-05	3.125E-05
3.175E-05	3.325E-05	3.375E-05	3.460E-05	3.550E-05
3.700E-05	3.800E-05	3.910E-05	3.960E-05	4.100E-05
4.240E-05	4.400E-05	4.520E-05	4.700E-05	4.830E-05
4.920E-05	5.060E-05	5.200E-05	5.340E-05	5.900E-05
6.100E-05	6.500E-05	6.750E-05	7.200E-05	7.600E-05
8.000E-05	8.200E-05	9.000E-05	1.000E-04	1.080E-04
1.150E-04	1.190E-04	1.220E-04	1.860E-04	1.925E-04
2.075E-04	2.100E-04	2.400E-04	2.850E-04	3.050E-04
5.500E-04	6.700E-04	6.830E-04	9.500E-04	1.150E-03
1.500E-03	1.550E-03	1.800E-03	2.200E-03	2.290E-03
2.580E-03	3.000E-03	3.740E-03	3.900E-03	6.000E-03
8.030E-03	9.500E-03	1.300E-02	1.700E-02	2.500E-02
3.000E-02	4.500E-02	5.000E-02	5.200E-02	6.000E-02
7.300E-02	7.500E-02	8.200E-02	8.500E-02	1.000E-01
1.283E-01	1.500E-01	2.000E-01	2.700E-01	3.300E-01
4.000E-01	4.200E-01	4.400E-01	4.700E-01	4.995E-01
5.500E-01	5.730E-01	6.000E-01	6.700E-01	6.790E-01
7.500E-01	8.200E-01	8.611E-01	8.750E-01	9.000E-01
9.200E-01	1.010E+00	1.100E+00	1.200E+00	1.250E+00
1.317E+00	1.356E+00	1.400E+00	1.500E+00	1.850E+00
2.354E+00	2.479E+00	3.000E+00	4.304E+00	4.800E+00
6.434E+00	8.187E+00	1.000E+01	1.284E+01	1.384E+01
1.455E+01	1.568E+01	1.733E+01	2.000E+01	

si3 h 0 381.00
m30 82000.50c 1.0 \$ Lead
m31 6000.50c -27.660 \$ Neutron Shield Holtite-A (NS-4-FR)
1001.50c -5.920
13027.50c -21.285
7014.50c -1.98
8016.50c -42.372
5010.50c -0.141
5011.50c -0.642

imp:n l 207r 0
c fuel enrichment 4.0 %
m1 92235.50c -0.03526
92238.50c -0.84624
8016.50c -0.11850
c end of file
c

HOLTEC INTERNATIONAL COPYRIGHTED MATERIAL

HI-STORM FSAR
REPORT HI-2002444

Rev. 1

Appendix 6.D-12

HI-TRAC Transfer Cask containing MPC68, 08x08 assembly @ 4.2 wt% Enrich.
 c reflected w/60cm of water, 0.0279 g/cmsq B-10 in Boral

c
 c
 1 1 -10.522 -1 u=2 \$ fuel
 2 4 -1.0 1 -2 u=2 \$ gap
 3 3 -6.55 2 -3 u=2 \$ Zr Clad
 4 4 -1.0 3 u=2 \$ water in fuel region
 5 4 -1.0 -4:5 u=3 \$ water in guide tubes
 6 4 -1.00 4 -5 u=3 \$ guide tubes
 7 4 -1.0 -6 +7 -8 +9 u=1 lat=1
 fill= -5:4 -5:4 0:0
 1 1 1 1 1 1 1 1 1
 1 2 2 2 2 2 2 2 1
 1 2 2 2 2 2 2 2 1
 1 2 2 2 2 2 2 2 1
 1 2 2 2 3 2 2 2 1
 1 2 2 2 2 3 2 2 1
 1 2 2 2 2 2 2 2 1
 1 2 2 2 2 2 2 2 1
 1 2 2 2 2 2 2 2 1
 1 2 2 2 2 2 2 2 1
 1 1 1 1 1 1 1 1 1

c
 C BOX TYPE R
 c

8 0 -10 11 -12 13 u=4 fill=1 (0.8128 0.8128 0)
 9 3 -6.55 60 -61 62 -63 #8 u=4 \$ Zr flow channel
 10 4 -1. 64 -65 66 -67 #8 #9 u=4 \$ water
 11 5 -7.84 20 -23 67 -14 u=4 \$ 0.075" STEEL
 12 4 -1. 20 -23 14 -15 u=4 \$ WATER POCKET
 13 7 -2.7 20 -23 15 -16 u=4 \$ Al CLAD
 14 6 -2.66 20 -23 16 -17 u=4 \$ BORAL Absorber
 15 7 -2.7 20 -23 17 -18 u=4 \$ Al Clad
 16 4 -1. 20 -23 18 -118 u=4 \$ Water
 17 5 -7.84 118:-129:65:-66 u=4 \$ Steel
 18 4 -1. 64 -21 67 -118 u=4 \$ Water
 19 4 -1. 24 -65 67 -118 u=4 \$ water
 20 5 -7.84 21 -20 67 -118 u=4 \$ Steel
 21 5 -7.84 23 -24 67 -118 u=4 \$ Steel
 22 4 -1. 129 -64 33 -118 u=4 \$ Water
 c
 23 5 -7.84 25 -64 30 -31 u=4 \$ Steel
 24 4 -1. 26 -25 30 -31 u=4 \$ Water
 25 7 -2.7 27 -26 30 -31 u=4 \$ Al clad
 26 6 -2.66 28 -27 30 -31 u=4 \$ Boral
 27 7 -2.7 29 -28 30 -31 u=4 \$ Al clad
 28 4 -1. 129 -29 30 -31 u=4 \$ water
 29 5 -7.84 129 -64 32 -30 u=4 \$ Steel ends
 30 5 -7.84 129 -64 31 -33 u=4 \$ Steel ends
 31 4 -1. 129 -64 66 -32 u=4 \$ Water

c
 c Type A box - Boral only on left side
 c

32 0 -10 11 -12 13 u=6 fill=1 (0.8128 0.8128 0)
 33 3 -6.55 60 -61 62 -63 #8 u=6 \$ Zr flow channel
 34 4 -1. 64 -65 66 -118 #8 #9 u=6 \$ water
 35 5 -7.84 118:-129:65:-66 u=6 \$ Steel
 36 4 -1. 129 -64 67 -118 u=6 \$ Water
 c
 37 5 -7.84 25 -64 30 -31 u=6 \$ Steel
 38 4 -1. 26 -25 30 -31 u=6 \$ Water
 39 7 -2.7 27 -26 30 -31 u=6 \$ Al clad

HOLTEC INTERNATIONAL COPYRIGHTED MATERIAL

HI-STORM FSAR
 REPORT HI-2002444

Appendix 6.D-13

Rev. 1

40	6	-2.66	28	-27	30	-31		u=6	\$ Boral
41	7	-2.7	29	-28	30	-31		u=6	\$ Al clad
42	4	-1.	129	-29	30	-31		u=6	\$ water
43	4	-1.	129	-64	33	-67		u=6	\$ Water
44	5	-7.84	129	-64	32	-30		u=6	\$ Steel ends
45	5	-7.84	129	-64	31	-33		u=6	\$ Steel ends
46	4	-1.	129	-64	66	-32		u=6	\$ Water
c									
c Type B box - Boral on Top only									
c									
47	0	-10	11	-12	13			u=7 fill=1	(0.8128 0.8128 0)
48	3	-6.55	60	-61	62	-63	#8	u=7	\$ Zr flow channel
49	4	-1.	64	-65	66	-67	#8 #9	u=7	\$ water
50	5	-7.84	20	-23	67	-14		u=7	\$ 0.075" STEEL
51	4	-1.	20	-23	14	-15		u=7	\$ WATER POCKET
52	7	-2.7	20	-23	15	-16		u=7	\$ Al CLAD
53	6	-2.66	20	-23	16	-17		u=7	\$ BORAL Absorber
54	7	-2.7	20	-23	17	-18		u=7	\$ water
55	4	-1.	20	-23	18	-118		u=7	\$ Water
56	5	-7.84	118:-129:65:-66					u=7	\$ Steel
57	4	-1.	64	-21	67	-118		u=7	\$ Water
58	4	-1.	24	-65	67	-118		u=7	\$ water
59	5	-7.84	21	-20	67	-118		u=7	\$ Steel
60	5	-7.84	23	-24	67	-118		u=7	\$ Steel
61	4	-1.	129	-64	66	-118		u=7	\$ Water
c									
c Type E box - No Boral Panels									
c									
62	0	-10	11	-12	13			u=8 fill=1	(0.8128 0.8128 0)
63	3	-6.55	60	-61	62	-63	#8	u=8	\$ Zr flow channel
64	4	-1.	129	-65	66	-118	#8 #9	u=8	\$ water
65	5	-7.84	118:-129:65:-66					u=8	\$ Steel
c									
c Type F box - No Boral Panels or fuel									
c									
66	4	-1.	129	-65	66	-118		u=9	\$ water
67	5	-7.84	118:-129:65:-66					u=9	\$ Steel
c									
68	4	-1.0	-34	35	-36	37		u=5 lat=1	fill=-7:6 -7:6 0:0
			5	5	5	5	5	5	5
			5	9	9	9	9	9	9
			5	9	9	9	7	4	9
			5	9	9	7	4	4	4
			5	9	9	7	4	4	4
			5	9	9	7	4	4	4
			5	9	9	7	4	4	4
			5	9	9	8	4	4	4
			5	9	9	8	4	4	4
			5	9	9	9	8	6	9
			5	9	9	9	9	9	9
			5	9	9	9	9	9	9
			5	5	5	5	5	5	5
69	0		-41					50	-49 fill=5 (8.1661 8.1661 0)
c									
274	4	-1.0	-41		360	-50			\$ Water below Fuel (7.3 in.)
275	5	-7.84	-42		362	-360			\$ MPC Steel below Fuel (2.5 in.)
276	5	-7.84	-205		300	-362			\$ Transfer Cask Steel (2.0 in.)
277	8	-11.34	-205		301	-300			\$ Transfer Cask Lead (2.5 in.)
278	5	-7.84	-205		302	-301			\$ Transfer Cask Steel (1.0 in.)
c									
279	4	-1.0	-41		49	-361			\$ Water above Fuel (8.46 in.)

HOLTEC INTERNATIONAL COPYRIGHTED MATERIAL

HI-STORM FSAR

Rev. 1

REPORT HI-2002444

Appendix 6.D-14

280	5	-7.84	-42	361	-363	\$ MPC Steel above Fuel (10.0 in)
281	4	-1.0	-42	363	-400	\$ Water (1.5 in.)
282	5	-7.84	-205	400	-401	\$ Transfer Cask Steel (0.75 in.)
283	9	-1.61	-205	401	-402	\$ Transfer Cask Neutron Shield (3.25 in.)
284	5	-7.84	-205	402	-403	\$ Transfer Cask Steel (0.5 in.)
c						
290	5	-7.84	41 -42	360	-361	\$ Radial Steel - MPC shell
291	4	-1.00	42 -200	362	-400	\$ Radial Water
292	5	-7.84	200 -201	362	-400	\$ Radial Steel - inner shell of Trnsfr Cask
293	8	-11.34	201 -202	362	-400	\$ Radial Lead - Transfer Cask lead
294	5	-7.84	202 -203	362	-400	\$ Radial Steel - outer shell of Trnsfr Cask
295	4	-1.00	203 -204	362	-400	\$ Radial Water - Water Jacket
296	5	-7.84	204 -205	362	-400	\$ Radial Steel - outer shell of Water Jacket
c						
500	4	-1.00	500 -501 -505	(205 :-302: 403)		\$ outer water reflector
501	0		505 :-500: 501			\$ outside world
1	cz	0.5283				\$ Fuel OD
2	cz	0.5398				\$ Clad ID
3	cz	0.6134				\$ Clad OD
4	cz	0.6744				\$ Thimble ID
5	cz	0.7506				\$ Thimble OD
6	px	0.8128				\$ Pin Pitch
7	px	-0.8128				
8	py	0.8128				
9	py	-0.8128				
10	px	6.6231				\$ Channel ID
11	px	-6.6231				
12	py	6.6231				
13	py	-6.6231				
14	py	7.8016				
15	py	7.8155				
16	py	7.8410				
17	py	8.0467				
18	py	8.0721				
118	py	8.0861				
20	px	-6.0325				
21	px	-6.2230				
23	px	6.0325				
24	px	6.2230				
25	px	-7.8016				
26	px	-7.8155				
27	px	-7.8410				
28	px	-8.0467				
29	px	-8.0721				
129	px	-8.0861				
30	py	-6.0325				
31	py	6.0325				
32	py	-6.2230				
33	py	6.2230				
34	px	7.6111				
35	px	-8.7211				
36	py	8.7211				
37	py	-7.6111				
49	pz	381.				\$ Top of Active Fuel
50	pz	0				\$ Start of Active Fuel
60	px	-6.9279				\$ Channel OD
61	px	6.9279				
62	py	-6.9279				
63	py	6.9279				
64	px	-7.6111				\$ Cell Box ID
65	px	7.6111				

HOLTEC INTERNATIONAL COPYRIGHTED MATERIAL

HI-STORM FSAR

Rev. 1

REPORT HI-2002444

Appendix 6.D-15

```

66 py -7.6111
67 py 7.6111
360 pz -18.54 $ lower water thkness = 7.30 in.
361 pz 402.49 $ upper water thkness = 8.46 in.
362 pz -24.892 $ thkness of MPC baseplate = 2.5 in.
363 pz 427.89 $ thkness of MPC lid = 10. in.
41 cz 85.57 $ I.D. = 67.375 in.
42 cz 86.84 $ I.D. = 68.375 in.
200 cz 87.31 $ I.D. = 68.75 in.
201 cz 89.22 $ I.D. = 70.25 in.
202 cz 100.65 $ I.D. = 79.25 in.
203 cz 103.19 $ I.D. = 81.25 in.
204 cz 116.80 $ I.D. = 91.97 in.
205 cz 118.07 $ I.D. = 92.972 in.
300 pz -29.97 $ thkness steel - 2.0 in.
301 pz -36.32 $ thkness lead - 2.5 in.
302 pz -38.86 $ thkness steel - 1.0 in.
400 pz 431.70 $ thkness water - 1.5 in.
401 pz 433.61 $ thkness steel - 0.75 in.
402 pz 441.87 $ thkness neutron shield - 3.25 in.
403 pz 443.14 $ thkness steel - 0.5 in.

```

```

c
*500 pz -68.86 $ lower boundary
*501 pz 473.14 $ upper boundary
*505 cz 148.07 $ outer radial boundary

```

```

imp:n 1 87r 0
kcode 10000 0.94 20 120
c
sdef par=1 erg=d1 axs=0 0 1 x=d4 y=fx d5 z=d3
c

```

```

sp1 -2 1.2895
c

```

```

si3 h 0 381.
sp3 0 1
c

```

```

c
si4 s 15 16
13 14 15 16 17 18
12 13 14 15 16 17 18 19
12 13 14 15 16 17 18 19
11 12 13 14 15 16 17 18 19 20
11 12 13 14 15 16 17 18 19 20
12 13 14 15 16 17 18 19
12 13 14 15 16 17 18 19
13 14 15 16 17 18
15 16

```

```

sp4 1 67r
c

```

```

ds5 s 30 30
29 29 29 29 29 29
28 28 28 28 28 28 28 28
27 27 27 27 27 27 27 27
26 26 26 26 26 26 26 26 26
25 25 25 25 25 25 25 25 25
24 24 24 24 24 24 24 24
23 23 23 23 23 23 23 23
22 22 22 22 22 22
21 21

```

```

c
si11 -80.6831 -67.6783
si12 -64.1985 -51.1937

```

HOLTEC INTERNATIONAL COPYRIGHTED MATERIAL

HI-STORM FSAR

Rev. 1

REPORT HI-2002444

Appendix 6.D-16

si13	-47.7139	-34.7091
si14	-31.2293	-18.2245
si15	-14.7447	-1.7399
si16	1.7399	14.7447
si17	18.2245	31.2293
si18	34.7091	47.7139
si19	51.1937	64.1985
si20	67.6783	80.6831
c		
si21	-80.6831	-67.6783
si22	-64.1985	-51.1937
si23	-47.7139	-34.7091
si24	-31.2293	-18.2245
si25	-14.7447	-1.7399
si26	1.7399	14.7447
si27	18.2245	31.2293
si28	34.7091	47.7139
si29	51.1937	64.1985
si30	67.6783	80.6831
sp11	0 1	
sp12	0 1	
sp13	0 1	
sp14	0 1	
sp15	0 1	
sp16	0 1	
sp17	0 1	
sp18	0 1	
sp19	0 1	
sp20	0 1	
sp21	0 1	
sp22	0 1	
sp23	0 1	
sp24	0 1	
sp25	0 1	
sp26	0 1	
sp27	0 1	
sp28	0 1	
sp29	0 1	
sp30	0 1	
c		

m1	92235.50c	-0.03702	\$ 4.20% E Fuel
	92238.50c	-0.84448	
	8016.50c	-0.1185	
m3	40000.56c	1.	\$ Zr Clad
m4	1001.50c	0.6667	\$ Water
	8016.50c	0.3333	
m5	24000.50c	0.01761	\$ Steel
	25055.50c	0.001761	
	26000.55c	0.05977	
	28000.50c	0.008239	
m6	5010.50c	8.0707E-03	\$ Boral
	5011.50c	3.2553E-02	
	6000.50c	1.0146E-02	
	13027.50c	3.8054E-02	
m7	13027.50c	1.	\$ Al Clad
m8	82000.50c	1.0	\$ Lead
m9	6000.50c	-27.660	\$ Neutron Shield Holtite-A (NS-4-FR)
	1001.50c	-5.920	
	13027.50c	-21.285	
	7014.50c	-1.98	
	8016.50c	-42.372	
	5010.50c	-0.141	

HOLTEC INTERNATIONAL COPYRIGHTED MATERIAL

HI-STORM FSAR
REPORT HI-2002444

Appendix 6.D-17

Rev. 1

```

                    5011.50c  -0.642
mt4                lwtr.01t
prdmp              j  -120  j  2
fm4                1000  1  -6
f4:n               1
sd4                1000
e4  1.000E-11  1.000E-10  5.000E-10  7.500E-10  1.000E-09  1.200E-09
     1.500E-09  2.000E-09  2.500E-09  3.000E-09
     4.700E-09  5.000E-09  7.500E-09  1.000E-08  2.530E-08
     3.000E-08  4.000E-08  5.000E-08  6.000E-08  7.000E-08
     8.000E-08  9.000E-08  1.000E-07  1.250E-07  1.500E-07
     1.750E-07  2.000E-07  2.250E-07  2.500E-07  2.750E-07
     3.000E-07  3.250E-07  3.500E-07  3.750E-07  4.000E-07
     4.500E-07  5.000E-07  5.500E-07  6.000E-07  6.250E-07
     6.500E-07  7.000E-07  7.500E-07  8.000E-07  8.500E-07
     9.000E-07  9.250E-07  9.500E-07  9.750E-07  1.000E-06
     1.010E-06  1.020E-06  1.030E-06  1.040E-06  1.050E-06
     1.060E-06  1.070E-06  1.080E-06  1.090E-06  1.100E-06
     1.110E-06  1.120E-06  1.130E-06  1.140E-06  1.150E-06
     1.175E-06  1.200E-06  1.225E-06  1.250E-06  1.300E-06
     1.350E-06  1.400E-06  1.450E-06  1.500E-06  1.590E-06
     1.680E-06  1.770E-06  1.860E-06  1.940E-06  2.000E-06
     2.120E-06  2.210E-06  2.300E-06  2.380E-06  2.470E-06
     2.570E-06  2.670E-06  2.770E-06  2.870E-06  2.970E-06
     3.000E-06  3.050E-06  3.150E-06  3.500E-06  3.730E-06
     4.000E-06  4.750E-06  5.000E-06  5.400E-06  6.000E-06
     6.250E-06  6.500E-06  6.750E-06  7.000E-06  7.150E-06
     8.100E-06  9.100E-06  1.000E-05  1.150E-05  1.190E-05
     1.290E-05  1.375E-05  1.440E-05  1.510E-05  1.600E-05
     1.700E-05  1.850E-05  1.900E-05  2.000E-05  2.100E-05
     2.250E-05  2.500E-05  2.750E-05  3.000E-05  3.125E-05
     3.175E-05  3.325E-05  3.375E-05  3.460E-05  3.550E-05
     3.700E-05  3.800E-05  3.910E-05  3.960E-05  4.100E-05
     4.240E-05  4.400E-05  4.520E-05  4.700E-05  4.830E-05
     4.920E-05  5.060E-05  5.200E-05  5.340E-05  5.900E-05
     6.100E-05  6.500E-05  6.750E-05  7.200E-05  7.600E-05
     8.000E-05  8.200E-05  9.000E-05  1.000E-04  1.080E-04
     1.150E-04  1.190E-04  1.220E-04  1.860E-04  1.925E-04
     2.075E-04  2.100E-04  2.400E-04  2.850E-04  3.050E-04
     5.500E-04  6.700E-04  6.830E-04  9.500E-04  1.150E-03
     1.500E-03  1.550E-03  1.800E-03  2.200E-03  2.290E-03
     2.580E-03  3.000E-03  3.740E-03  3.900E-03  6.000E-03
     8.030E-03  9.500E-03  1.300E-02  1.700E-02  2.500E-02
     3.000E-02  4.500E-02  5.000E-02  5.200E-02  6.000E-02
     7.300E-02  7.500E-02  8.200E-02  8.500E-02  1.000E-01
     1.283E-01  1.500E-01  2.000E-01  2.700E-01  3.300E-01
     4.000E-01  4.200E-01  4.400E-01  4.700E-01  4.995E-01
     5.500E-01  5.730E-01  6.000E-01  6.700E-01  6.790E-01
     7.500E-01  8.200E-01  8.611E-01  8.750E-01  9.000E-01
     9.200E-01  1.010E+00  1.100E+00  1.200E+00  1.250E+00
     1.317E+00  1.356E+00  1.400E+00  1.500E+00  1.850E+00
     2.354E+00  2.479E+00  3.000E+00  4.304E+00  4.800E+00
     6.434E+00  8.187E+00  1.000E+01  1.284E+01  1.384E+01
     1.455E+01  1.568E+01  1.733E+01  2.000E+01

```

HOLTEC INTERNATIONAL COPYRIGHTED MATERIAL

HI-STORM FSAR

Rev. 1

REPORT HI-2002444

Appendix 6.D-18

HI-STORM Storage Cask containing MPC24, 17x17 assembly @ 4.0 wt% Enrich.

c
c
c
c MPC-24/24E cell configuration
c
c HI-STORM with active length 150 inch
c
c
c Cask Input Preprocessor
c cskipn 17a 17a mpc24n mpc24n historm historm 4.0 4sf7a45 empty
c ----- cpp\17a.bat
c added 17a.ce
c added 17a.su
c added 17a.sp
c ----- cpp\mpc24n.bat
c added mpc24n.co
c added mpc24n.ce
c added mpc24n.su
c added mpc24n.sp
c ----- cpp\historm.bat
c added historm.co
c added historm.ce
c added historm.su
c added historm.sp
c end of comments

c
c start of cells
c
c 17x17a
c
c number of cells: 6
c cell numbers: 1 to 7
c univers numbers: 1 to 3
c surface numbers: 1 to 9
c

c number of cells: 1
1 1 -10.522 -1 u=2 \$ fuel
2 4 -1.0 1 -2 u=2 \$ gap
3 3 -6.55 2 -3 u=2 \$ Zr Clad
4 2 -0.0002 3 u=2 \$ water in fuel region
5 2 -0.0002 -4:5 u=3 \$ water in guide tubes
6 3 -6.55 4 -5 u=3 \$ guide tubes
7 2 -0.0002 -6 +7 -8 +9 u=1 lat=1
fill= -9:9 -9:9 0:0
1 1 1 1 1 1 1 1 1 1 1 1 1 1 1 1 1 1
1 2 2 2 2 2 2 2 2 2 2 2 2 2 2 2 2 1
1 2 2 2 2 2 2 2 2 2 2 2 2 2 2 2 2 1
1 2 2 2 2 2 3 2 2 3 2 2 3 2 2 2 2 1
1 2 2 2 3 2 2 2 2 2 2 2 2 3 2 2 2 1
1 2 2 2 2 2 2 2 2 2 2 2 2 2 2 2 2 1
1 2 2 3 2 2 3 2 2 3 2 2 3 2 2 3 2 2 1
1 2 2 2 2 2 2 2 2 2 2 2 2 2 2 2 2 1
1 2 2 2 2 2 2 2 2 2 2 2 2 2 2 2 2 1
1 2 2 2 2 2 2 2 2 2 2 2 2 2 2 2 2 1
1 2 2 2 2 2 2 2 2 2 2 2 2 2 2 2 2 1
1 2 2 2 2 2 2 2 2 2 2 2 2 2 2 2 2 1
1 2 2 2 2 2 2 2 2 2 2 2 2 2 2 2 2 1
1 2 2 2 2 2 2 2 2 2 2 2 2 2 2 2 2 1
1 2 2 2 2 2 2 2 2 2 2 2 2 2 2 2 2 1
1 2 2 2 2 2 2 2 2 2 2 2 2 2 2 2 2 1
1 2 2 2 2 2 2 2 2 2 2 2 2 2 2 2 2 1
1 2 2 2 2 2 2 2 2 2 2 2 2 2 2 2 2 1
1 2 2 2 2 2 2 2 2 2 2 2 2 2 2 2 2 1

HOLTEC INTERNATIONAL COPYRIGHTED MATERIAL

HI-STORM FSAR
REPORT HI-2002444

Appendix 6.D-19

Rev. 1

1 2 2 2 2 2 2 2 2 2 2 2 2 2 2 2 1
 1 1 1 1 1 1 1 1 1 1 1 1 1 1 1 1 1

c

MPC-24

c

c number of cells: 102

c cell numbers : 400 to 699

c universe numbers : 4 to 9

c surface numbers : 400 to 699

c

Right Side

c

408	0	-410	411	-412	413	u=4 fill=1 (1)
409	5 -7.84	410	-424	413	-426	u=4
410	2 -0.0002	424	-428	448	-445	u=4
411	7 -2.7	428	-528	448	-445	u=4
412	6 -2.66	528	-532	448	-445	u=4
413	7 -2.7	532	-432	448	-445	u=4
414	2 -0.0002	432	-436	448	-445	u=4
415	5 -7.84	436	-440	448	-445	u=4
416	2 -0.0002	440		413		u=4
417	2 -0.0002	424	-440	413	-447	u=4
418	2 -0.0002	424	-440	446		u=4
419	5 -7.84	424	-440	447	-448	u=4
420	5 -7.84	424	-440	445	-446	u=4

c

Left Side

c

421	5 -7.84	425	-411	413		u=4
422	2 -0.0002	429	-425	448	-445	u=4
423	7 -2.7	529	-429	448	-445	u=4
424	6 -2.66	533	-529	448	-445	u=4
425	7 -2.7	433	-533	448	-445	u=4
426	2 -0.0002	437	-433	448	-445	u=4
427	5 -7.84	441	-437	448	-445	u=4
428	2 -0.0002		-441	413		u=4
429	2 -0.0002	441	-425	413	-447	u=4
430	2 -0.0002	441	-425	446		u=4
431	5 -7.84	441	-425	447	-448	u=4
432	5 -7.84	441	-425	445	-446	u=4

c

Top

c

433	5 -7.84	411	-410	412	-426	u=4
434	2 -0.0002	451	-452	426	-430	u=4
435	7 -2.7	451	-452	430	-530	u=4
436	6 -2.66	451	-452	530	-534	u=4
437	7 -2.7	451	-452	534	-434	u=4
438	2 -0.0002	451	-452	434	-438	u=4
439	5 -7.84	451	-452	438	-442	u=4
440	2 -0.0002	411	-424	442		u=4
441	2 -0.0002	411	-450	426	-442	u=4
442	2 -0.0002	453	-424	426	-442	u=4
443	5 -7.84	450	-451	426	-442	u=4
444	5 -7.84	452	-453	426	-442	u=4

c

Bottom

c

445	5 -7.84	427		-413		u=4
446	2 -0.0002	451	-452	431	-427	u=4
447	7 -2.7	451	-452	531	-431	u=4
448	6 -2.66	451	-452	535	-531	u=4

HOLTEC INTERNATIONAL COPYRIGHTED MATERIAL

HI-STORM FSAR

Rev. 1

REPORT HI-2002444

Appendix 6.D-20

```

449 7 -2.7 451 -452 435 -535 u=4
450 2 -0.0002 451 -452 439 -435 u=4
451 5 -7.84 451 -452 443 -439 u=4
452 2 -0.0002 411 -443 u=4
453 2 -0.0002 411 -450 443 -427 u=4
454 2 -0.0002 453 443 -427 u=4
455 5 -7.84 450 -451 443 -427 u=4
456 5 -7.84 452 -453 443 -427 u=4
457 5 -7.84 425 -411 -427 u=4
458 2 -0.0002 -425 -427 u=4
c
c TYPE B CELL - Short Boral on top and right
c
c Right Side
c
459 0 -410 411 -412 413 u=5 fill=1 (1)
460 5 -7.84 410 -424 413 -426 u=5
470 2 -0.0002 424 -428 548 -545 u=5
471 7 -2.7 428 -528 548 -545 u=5
472 6 -2.66 528 -532 548 -545 u=5
473 7 -2.7 532 -432 548 -545 u=5
474 2 -0.0002 432 -436 548 -545 u=5
475 5 -7.84 436 -440 548 -545 u=5
476 2 -0.0002 440 413 u=5
477 2 -0.0002 424 -440 413 -547 u=5
478 2 -0.0002 424 -440 546 u=5
479 5 -7.84 424 -440 547 -548 u=5
480 5 -7.84 424 -440 545 -546 u=5
c
c Left Side
c
481 5 -7.84 425 -411 413 u=5
482 2 -0.0002 429 -425 448 -445 u=5
483 7 -2.7 529 -429 448 -445 u=5
484 6 -2.66 533 -529 448 -445 u=5
485 7 -2.7 433 -533 448 -445 u=5
486 2 -0.0002 437 -433 448 -445 u=5
487 5 -7.84 441 -437 448 -445 u=5
488 2 -0.0002 -441 413 u=5
489 2 -0.0002 441 -425 413 -447 u=5
490 2 -0.0002 441 -425 446 u=5
491 5 -7.84 441 -425 447 -448 u=5
492 5 -7.84 441 -425 445 -446 u=5
c
c Top
c
493 5 -7.84 411 -410 412 -426 u=5
494 2 -0.0002 551 -552 426 -430 u=5
495 7 -2.7 551 -552 430 -530 u=5
496 6 -2.66 551 -552 530 -534 u=5
497 7 -2.7 551 -552 534 -434 u=5
498 2 -0.0002 551 -552 434 -438 u=5
499 5 -7.84 551 -552 438 -442 u=5
500 2 -0.0002 411 -424 442 u=5
501 2 -0.0002 411 -550 426 -442 u=5
502 2 -0.0002 553 -424 426 -442 u=5
503 5 -7.84 550 -551 426 -442 u=5
504 5 -7.84 552 -553 426 -442 u=5
c
c Bottom
c
505 5 -7.84 427 -413 u=5

```

HOLTEC INTERNATIONAL COPYRIGHTED MATERIAL

HI-STORM FSAR
REPORT HI-2002444

Appendix 6.D-21

Rev. 1

506	2	-0.0002	451	-452	431	-427	u=5
507	7	-2.7	451	-452	531	-431	u=5
508	6	-2.66	451	-452	535	-531	u=5
509	7	-2.7	451	-452	435	-535	u=5
510	2	-0.0002	451	-452	439	-435	u=5
511	5	-7.84	451	-452	443	-439	u=5
512	2	-0.0002	411			-443	u=5
513	2	-0.0002	411	-450	443	-427	u=5
514	2	-0.0002	453		443	-427	u=5
515	5	-7.84	450	-451	443	-427	u=5
516	5	-7.84	452	-453	443	-427	u=5
517	5	-7.84	425	-411		-427	u=5
518	2	-0.0002		-425		-427	u=5

c
c
c

TYPE D CELL - Short Boral on left and bottom, different cell ID

c
c number of cells: 51

c
c Right Side

1570	0		-1410	1411	-1412	1413	u=17 fill=1 (1)
1571	5	-7.84	1410	-1424	1413	-1426	u=17
1572	2	-0.0002	1424	-1428	1448	-1445	u=17
1573	7	-2.7	1428	-1528	1448	-1445	u=17
1574	6	-2.66	1528	-1532	1448	-1445	u=17
1575	7	-2.7	1532	-1432	1448	-1445	u=17
1576	2	-0.0002	1432	-1436	1448	-1445	u=17
1577	5	-7.84	1436	-1440	1448	-1445	u=17
1578	2	-0.0002	1440		1413		u=17
1579	2	-0.0002	1424	-1440	1413	-1447	u=17
1580	2	-0.0002	1424	-1440	1446		u=17
1581	5	-7.84	1424	-1440	1447	-1448	u=17
1582	5	-7.84	1424	-1440	1445	-1446	u=17

c
c Left Side

1583	5	-7.84	1425	-1411	1413		u=17
1584	2	-0.0002	1429	-1425	1548	-1545	u=17
1585	7	-2.7	1529	-1429	1548	-1545	u=17
1586	6	-2.66	1533	-1529	1548	-1545	u=17
1587	7	-2.7	1433	-1533	1548	-1545	u=17
1588	2	-0.0002	1437	-1433	1548	-1545	u=17
1589	5	-7.84	1441	-1437	1548	-1545	u=17
1590	2	-0.0002		-1441	1413		u=17
1591	2	-0.0002	1441	-1425	1413	-1547	u=17
1592	2	-0.0002	1441	-1425	1546		u=17
1593	5	-7.84	1441	-1425	1547	-1548	u=17
1594	5	-7.84	1441	-1425	1545	-1546	u=17

c
c Top

1595	5	-7.84	1411	-1410	1412	-1426	u=17
1596	2	-0.0002	1451	-1452	1426	-1430	u=17
1597	7	-2.7	1451	-1452	1430	-1530	u=17
1598	6	-2.66	1451	-1452	1530	-1534	u=17
1599	7	-2.7	1451	-1452	1534	-1434	u=17
1600	2	-0.0002	1451	-1452	1434	-1438	u=17
1601	5	-7.84	1451	-1452	1438	-1442	u=17
1602	2	-0.0002	1411	-1424	1442		u=17
1603	2	-0.0002	1411	-1450	1426	-1442	u=17

HOLTEC INTERNATIONAL COPYRIGHTED MATERIAL

HI-STORM FSAR
REPORT HI-2002444

Appendix 6.D-22

Rev. 1

1604 2 -0.0002 1453 -1424 1426 -1442 u=17
 1605 5 -7.84 1450 -1451 1426 -1442 u=17
 1606 5 -7.84 1452 -1453 1426 -1442 u=17

c

c Bottom

c

1607 5 -7.84 1427 -1413 u=17
 1608 2 -0.0002 1551 -1552 1431 -1427 u=17
 1609 7 -2.7 1551 -1552 1531 -1431 u=17
 1610 6 -2.66 1551 -1552 1535 -1531 u=17
 1611 7 -2.7 1551 -1552 1435 -1535 u=17
 1612 2 -0.0002 1551 -1552 1439 -1435 u=17
 1613 5 -7.84 1551 -1552 1443 -1439 u=17
 1614 2 -0.0002 1411 -1443 u=17
 1615 2 -0.0002 1411 -1550 1443 -1427 u=17
 1616 2 -0.0002 1553 1443 -1427 u=17
 1617 5 -7.84 1550 -1551 1443 -1427 u=17
 1618 5 -7.84 1552 -1553 1443 -1427 u=17
 1619 5 -7.84 1425 -1411 -1427 u=17
 1620 2 -0.0002 -1425 -1427 u=17

c

c number of cells: 29

c

c empty cell no boron, no top

c

c

751 2 -0.0002 -410 411 -412 413 u=14
 752 5 -7.84 410 -424 413 -426 u=14
 753 5 -7.84 425 -411 413 u=14
 754 2 -0.0002 411 -410 412 -426 u=14
 755 5 -7.84 427 -413 u=14
 756 5 -7.84 425 -411 -427 u=14
 757 2 -0.0002 411 426 u=14
 758 2 -0.0002 411 -427 u=14
 759 2 -0.0002 -425 413 u=14
 760 2 -0.0002 424 413 -426 u=14
 761 2 -0.0002 -425 -427 u=14

c

c

701 5 -7.84 701 -702 711 -713 u=9 \$ steel post
 702 5 -7.84 702 -703 711 -712 u=9 \$ steel post

c

711 0 701 -705 711 -715 (702:713) (703:712)
 fill=4 (13.8506 13.8506 0) u=9
 712 0 704 (-706:-716) (705:715) -717 -710
 fill=4 (17.9489 41.5518 0 0 1 0 -1 0 0 0 0 1) u=9
 713 0 (705:715) -707 714 (-706:-716) 710
 fill=4 (41.5518 17.9489 0 0 -1 0 1 0 0 0 0 1) u=9
 714 0 701 -705 717 -719
 fill=5 (13.8506 69.253 0) u=9
 715 0 707 -709 711 -715
 fill=5 (69.253 13.8506 0) u=9
 716 0 706 -708 716 -718
 fill=17 (45.6501 45.6501 0 -1 0 0 0 -1 0 0 0 1) u=9
 717 0 705 -706 717 -719
 fill=14 (41.5518 69.253 0) u=9
 718 0 707 -709 715 -716
 fill=14 (69.253 41.5518 0 0 1 0 1 0 0 0 0 1) u=9
 719 0 701 -704 715 -717
 fill=14 (-9.75233 41.5518 0 -1 0 0 0 1 0 0 0 1) u=9
 720 0 705 -707 711 -714
 fill=14 (41.5518 -9.75233 0 0 -1 0 1 0 0 0 0 1) u=9

HOLTEC INTERNATIONAL COPYRIGHTED MATERIAL

HI-STORM FSAR

Rev. 1

REPORT HI-2002444

Appendix 6.D-23

```

721  2 -0.0002      (706:719) (708:718) (709:716) u=9
c
c
c
731  2 -0.0002      720 721  fill=9 (0 0 0) u=19
732  2 -0.0002     -720 721  fill=9 (0 0 0
-1 0 0 0 1 0 0 0 1) u=19
733  2 -0.0002      720 -721 fill=9 (0 0 0
1 0 0 0 -1 0 0 0 1) u=19
734  2 -0.0002     -720 -721 fill=9 (0 0 0
-1 0 0 0 -1 0 0 0 1) u=19
c
673  0              -41          39 -40 fill=19
c
c number of cells: 19
374  2 -0.0002 -41          330 -39          $ Void below Fuel (4 in.)
375  5 -7.84 -309          332 -330         $ MPC Steel below Fuel (2.5 in.)
376  5 -7.84 -304          310 -332         $ Cask Steel (5.0 in.)
377  8 -2.35 -304          311 -310         $ Cask Concrete (17.0 in.)
378  5 -7.84 -304          312 -311         $ Cask Steel (2.0 in.)
c
379  2 -0.0002 -41          40 -331         $ Void above Fuel (6 in.)
380  5 -7.84 -309          331 -333         $ MPC Steel above Fuel (9.5 - 0.06 in)
381  4 -1.0 -309          333 -320         $ Water (1.0 in.)
382  5 -7.84 -304          320 -321         $ Cask Steel (1.25 in.)
383  8 -2.35 -304          321 -322         $ Cask Concrete (10.5 in.)
384  5 -7.84 -304          322 -323         $ Cask Steel (4.0 in.)
c
390  5 -7.84 41 -309 330 -331         $ Radial Steel - MPC shell
391  4 -1.00 309 -300 332 -320         $ Radial Water
392  5 -7.84 300 -301 332 -320         $ Radial Steel - overpack inner shell
394  5 -7.84 301 -302 332 -320         $ Radial Steel -
395  8 -2.35 302 -303 332 -320         $ Radial Shield - Concrete Overpack
396  5 -7.84 303 -304 332 -320         $ Radial Steel - overpack outer shell
c
300  4 -1.00 340 -341 -345          (304 :-312: 323) $ outer water reflector
301  0          345 :-340: 341          $ outside world
c end of cells
c --- empty line

c --- empty line
c start of surfaces
1    cz          0.3922  $ fuel
2    cz          0.4001  $ clad ID
3    cz          0.4572  $ clad OD
4    cz          0.5613  $ guide ID
5    cz          0.6020  $ guide OD
6    px          0.6299  $ pin pitch
7    px          -0.6299
8    py          0.6299
9    py          -0.6299
c
c
c cell-id      8.98
c cell-pitch   10.906
c wall-thkns   5/16
c angle-thkns  5/16
c boral-gap    0.0035
c boral-gap-o  0.0035
c boral-thkns  0.075
c boral-clad   0.01
c sheathing    0.0235

```

HOLTEC INTERNATIONAL COPYRIGHTED MATERIAL

HI-STORM FSAR

Rev. 1

REPORT HI-2002444

Appendix 6.D-24

HI-STORM 100 FSAR, NON-PROPRIETARY

REVISION 12

MARCH 12, 2014

c boral-wide 7.5
 c boral-narrow 6.25
 c
 c gap size 1.09
 c basket-od 67.335
 c

410	px	11.40460	\$x	8.98/2	
411	px	-11.40460	\$x	{410} *-1	
412	py	11.40460	\$x	{410}	
413	py	-11.40460	\$x	{411}	
416	px	13.85062	\$x	(10.906 + 5/16 - 5/16) /2	
417	px	-13.85062	\$x	-10.906 + {416}	
418	py	13.85062	\$x	{416}	
419	py	-13.85062	\$x	{417}	
424	px	12.19835	\$x	{410} + 5/16	\$ angle
425	px	-12.19835	\$x	{411} - 5/16	\$ box wall
426	py	12.19835	\$x	{412} + 5/16	
427	py	-12.19835	\$x	{413} - 5/16	
428	px	12.20724	\$x	{424} + 0.0035	\$ wall to boral gap
429	px	-12.20724	\$x	{425} - 0.0035	
430	py	12.20724	\$x	{426} + 0.0035	
431	py	-12.20724	\$x	{427} - 0.0035	
432	px	12.39774	\$x	{428} + 0.075	\$ boral
433	px	-12.39774	\$x	{429} - 0.075	
434	py	12.39774	\$x	{430} + 0.075	
435	py	-12.39774	\$x	{431} - 0.075	
436	px	12.40663	\$x	{432} + 0.0035	\$ boral to sheathing gap
437	px	-12.40663	\$x	{433} - 0.0035	
438	py	12.40663	\$x	{434} + 0.0035	
439	py	-12.40663	\$x	{435} - 0.0035	
440	px	12.46632	\$x	{436} + 0.0235	\$ sheathing
441	px	-12.46632	\$x	{437} - 0.0235	
442	py	12.46632	\$x	{438} + 0.0235	
443	py	-12.46632	\$x	{439} - 0.0235	
445	py	9.52500	\$x	7.5/2	
446	py	9.58469	\$x	{445} + 0.0235	\$ sheathing
447	py	-9.58469	\$x	{446} *-1	
448	py	-9.52500	\$x	{445} *-1	
450	px	-9.58469	\$x	{447}	
451	px	-9.52500	\$x	{448}	
452	px	9.52500	\$x	{445}	
453	px	9.58469	\$x	{446}	
528	px	12.23264	\$x	{428} + 0.01	\$ Aluminum on the outside of boral
529	px	-12.23264	\$x	{429} - 0.01	
530	py	12.23264	\$x	{430} + 0.01	
531	py	-12.23264	\$x	{431} - 0.01	
532	px	12.37234	\$x	{432} - 0.01	
533	px	-12.37234	\$x	{433} + 0.01	
534	py	12.37234	\$x	{434} - 0.01	
535	py	-12.37234	\$x	{435} + 0.01	
545	py	7.93750	\$x	6.25/2	
546	py	7.99719	\$x	{545} + 0.0235	\$ sheathing
547	py	-7.99719	\$x	{546} *-1	
548	py	-7.93750	\$x	{545} *-1	
550	px	-7.99719	\$x	{547}	
551	px	-7.93750	\$x	{548}	
552	px	7.93750	\$x	{545}	
553	px	7.99719	\$x	{546}	

c
 c cell-id-2 8.98
 c gap-o 1.09
 c

HOLTEC INTERNATIONAL COPYRIGHTED MATERIAL

HI-STORM FSAR

Rev. 1

REPORT HI-2002444

Appendix 6.D-25

```

701 px -5.0
702 px 1.90627 $x (10.906 - 8.98)/2 - 5/16 + 0.1
703 px 3.45694 $x 2.722/2
704 px 4.09829 $x 10.906 - 8.98 - 5/16
705 px 27.70124 $x 10.906
706 px 31.79953 $x 2 * 10.906 - (8.98+8.98)/2 - 5/16
707 px 55.40248 $x 2 * 10.906
708 px 59.50077 $x {707} + {704}
709 px 83.10372 $x 3 * 10.906
710 p 1 -1 0 0.1 $ diagonal x=y, offset by 0.1 to avoid intersecting corners
711 py -4.99999 $x {701}
712 py 1.90627 $x {702}
713 py 3.45694 $x {703}
714 py 4.09829 $x {704}
715 py 27.70124 $x {705}
716 py 31.79953 $x {706}
717 py 55.40248 $x {707}
718 py 59.50077 $x {708}
719 py 83.10372 $x {709}
720 px 0.0
721 py 0.0
1410 px 11.40460 $x 8.98/2
1411 px -11.40460 $x {1410} *-1
1412 py 11.40460 $x {1410}
1413 py -11.40460 $x {1411}
1424 px 12.19835 $x {1410} + 5/16 $ angle
1425 px -12.19835 $x {1411} - 5/16 $ box wall
1426 py 12.19835 $x {1412} + 5/16
1427 py -12.19835 $x {1413} - 5/16
1428 px 12.20724 $x {1424} + 0.0035 $ wall to boral gap
1429 px -12.20724 $x {1425} - 0.0035
1430 py 12.20724 $x {1426} + 0.0035
1431 py -12.20724 $x {1427} - 0.0035
1432 px 12.39774 $x {1428} + 0.075 $ boral
1433 px -12.39774 $x {1429} - 0.075
1434 py 12.39774 $x {1430} + 0.075
1435 py -12.39774 $x {1431} - 0.075
1436 px 12.40663 $x {1432} + 0.0035 $ boral to sheathing gap
1437 px -12.40663 $x {1433} - 0.0035
1438 py 12.40663 $x {1434} + 0.0035
1439 py -12.40663 $x {1435} - 0.0035
1440 px 12.46632 $x {1436} + 0.0235 $ sheathing
1441 px -12.46632 $x {1437} - 0.0235
1442 py 12.46632 $x {1438} + 0.0235
1443 py -12.46632 $x {1439} - 0.0235
1445 py 9.52500 $x 7.5/2
1446 py 9.58469 $x {1445} + 0.0235 $ sheathing
1447 py -9.58469 $x {1446} *-1
1448 py -9.52500 $x {1445} *-1
1450 px -9.58469 $x {1447}
1451 px -9.52500 $x {1448}
1452 px 9.52500 $x {1445}
1453 px 9.58469 $x {1446}
1528 px 12.23264 $x {1428} + 0.01 $ Aluminum on the outside of boral
1529 px -12.23264 $x {1429} - 0.01
1530 py 12.23264 $x {1430} + 0.01
1531 py -12.23264 $x {1431} - 0.01
1532 px 12.37234 $x {1432} - 0.01
1533 px -12.37234 $x {1433} + 0.01
1534 py 12.37234 $x {1434} - 0.01
1535 py -12.37234 $x {1435} + 0.01
1545 py 7.93750 $x 6.25/2

```

HOLTEC INTERNATIONAL COPYRIGHTED MATERIAL

HI-STORM FSAR

Rev. 1

REPORT HI-2002444

Appendix 6.D-26

```

1546 py 7.99719 $x {1545} + 0.0235 $ sheathing
1547 py -7.99719 $x {1546} *-1
1548 py -7.93750 $x {1545} *-1
1550 px -7.99719 $x {1547}
1551 px -7.93750 $x {1548}
1552 px 7.93750 $x {1545}
1553 px 7.99719 $x {1546}
39 pz 0.
40 pz 381.0 $ 150 inch active fuel length
330 pz -10.16 $ lower water thkness = 4 in.
331 pz 396.24 $ upper water thkness = 6 in.
332 pz -16.51 $ thkness of MPC baseplate = 2.5 in.
333 pz 420.02 $ thkness of MPC lid = 9.5 -0.06 in.
41 cz 85.57 $ I.D. = 67.37 in
309 cz 86.84 $ I.D. = 68.375 in.
300 cz 93.35 $ I.D. = 73.50 in.
301 cz 96.52 $ I.D. = 76.00 in.
302 cz 98.43 $ I.D. = 77.50 in.
303 cz 166.37 $ I.D. = 131.00 in.
304 cz 168.28 $ I.D. = 132.50 in.
310 pz -29.21 $ thkness steel - 5.0 in.
311 pz -72.39 $ thkness concrete - 17.0 in.
312 pz -77.47 $ thkness steel - 2.0 in.
320 pz 422.76 $ thkness water - 1.0 in.
321 pz 425.94 $ thkness steel - 1.25 in.
322 pz 452.61 $ thkness concrete - 10.5 in.
323 pz 462.765 $ thkness steel - 4.0 in.
c
*340 pz -107.47 $ lower boundary
*341 pz 492.765 $ upper boundary
*345 cz 198.28 $ outer radial boundary
c end of surfaces
c --- empty line

c --- empty line
tr1 0 0 0
kcode 10000 .94 20 120
sdef par=1 erg=d1 axs=0 0 1 x=d4 y=fx d5 z=d3
c
sp1 -2 1.2895
c
sp3 0 1
c
si4 s 13 14
12 13 14 15
11 12 13 14 15 16
11 12 13 14 15 16
12 13 14 15
13 14

sp4 1 23r
c
ds5 s 26 26
25 25 25 25
24 24 24 24 24 24
23 23 23 23 23 23
22 22 22 22
21 21

c
si11 -79.25435 -57.61355
si12 -51.88077 -30.23997
si13 -24.50719 -2.86639
si14 2.86639 24.50719

```

HOLTEC INTERNATIONAL COPYRIGHTED MATERIAL

HI-STORM FSAR

Rev. 1

REPORT HI-2002444

Appendix 6.D-27


```

si15 30.23997 51.88077
si16 57.61355 79.25435
c
si21 -79.25435 -57.61355
si22 -51.88077 -30.23997
si23 -24.50719 -2.86639
si24 2.86639 24.50719
si25 30.23997 51.88077
si26 57.61355 79.25435
c
sp11 0 1
sp12 0 1
sp13 0 1
sp14 0 1
sp15 0 1
sp16 0 1
sp21 0 1
sp22 0 1
sp23 0 1
sp24 0 1
sp25 0 1
sp26 0 1
c
m3 40000.56c 1. $ Zr Clad
m4 1001.50c 0.6667 $ Water
8016.50c 0.3333
m5 24000.50c 0.01761 $ Steel
25055.50c 0.001761
26000.55c 0.05977
28000.50c 0.008239
m6 5010.50c -0.054427 $ Boral Central Section @ 0.02 g/cmsq
5011.50c -0.241373
13027.50c -0.6222
6000.50c -0.0821
m7 13027.50c 1.0
mt4 lwtr.01t
prdmp j -120 j 2
fm4 1000 1 -6
f4:n 1
sd4 1000
e4 1.000E-11 1.000E-10 5.000E-10 7.500E-10 1.000E-09 1.200E-09
1.500E-09 2.000E-09 2.500E-09 3.000E-09
4.700E-09 5.000E-09 7.500E-09 1.000E-08 2.530E-08
3.000E-08 4.000E-08 5.000E-08 6.000E-08 7.000E-08
8.000E-08 9.000E-08 1.000E-07 1.250E-07 1.500E-07
1.750E-07 2.000E-07 2.250E-07 2.500E-07 2.750E-07
3.000E-07 3.250E-07 3.500E-07 3.750E-07 4.000E-07
4.500E-07 5.000E-07 5.500E-07 6.000E-07 6.250E-07
6.500E-07 7.000E-07 7.500E-07 8.000E-07 8.500E-07
9.000E-07 9.250E-07 9.500E-07 9.750E-07 1.000E-06
1.010E-06 1.020E-06 1.030E-06 1.040E-06 1.050E-06
1.060E-06 1.070E-06 1.080E-06 1.090E-06 1.100E-06
1.110E-06 1.120E-06 1.130E-06 1.140E-06 1.150E-06
1.175E-06 1.200E-06 1.225E-06 1.250E-06 1.300E-06
1.350E-06 1.400E-06 1.450E-06 1.500E-06 1.590E-06
1.680E-06 1.770E-06 1.860E-06 1.940E-06 2.000E-06
2.120E-06 2.210E-06 2.300E-06 2.380E-06 2.470E-06
2.570E-06 2.670E-06 2.770E-06 2.870E-06 2.970E-06
3.000E-06 3.050E-06 3.150E-06 3.500E-06 3.730E-06
4.000E-06 4.750E-06 5.000E-06 5.400E-06 6.000E-06
6.250E-06 6.500E-06 6.750E-06 7.000E-06 7.150E-06
8.100E-06 9.100E-06 1.000E-05 1.150E-05 1.190E-05

```

HOLTEC INTERNATIONAL COPYRIGHTED MATERIAL

HI-STORM FSAR
REPORT HI-2002444

Appendix 6.D-28

Rev. 1

1.290E-05	1.375E-05	1.440E-05	1.510E-05	1.600E-05
1.700E-05	1.850E-05	1.900E-05	2.000E-05	2.100E-05
2.250E-05	2.500E-05	2.750E-05	3.000E-05	3.125E-05
3.175E-05	3.325E-05	3.375E-05	3.460E-05	3.550E-05
3.700E-05	3.800E-05	3.910E-05	3.960E-05	4.100E-05
4.240E-05	4.400E-05	4.520E-05	4.700E-05	4.830E-05
4.920E-05	5.060E-05	5.200E-05	5.340E-05	5.900E-05
6.100E-05	6.500E-05	6.750E-05	7.200E-05	7.600E-05
8.000E-05	8.200E-05	9.000E-05	1.000E-04	1.080E-04
1.150E-04	1.190E-04	1.220E-04	1.860E-04	1.925E-04
2.075E-04	2.100E-04	2.400E-04	2.850E-04	3.050E-04
5.500E-04	6.700E-04	6.830E-04	9.500E-04	1.150E-03
1.500E-03	1.550E-03	1.800E-03	2.200E-03	2.290E-03
2.580E-03	3.000E-03	3.740E-03	3.900E-03	6.000E-03
8.030E-03	9.500E-03	1.300E-02	1.700E-02	2.500E-02
3.000E-02	4.500E-02	5.000E-02	5.200E-02	6.000E-02
7.300E-02	7.500E-02	8.200E-02	8.500E-02	1.000E-01
1.283E-01	1.500E-01	2.000E-01	2.700E-01	3.300E-01
4.000E-01	4.200E-01	4.400E-01	4.700E-01	4.995E-01
5.500E-01	5.730E-01	6.000E-01	6.700E-01	6.790E-01
7.500E-01	8.200E-01	8.611E-01	8.750E-01	9.000E-01
9.200E-01	1.010E+00	1.100E+00	1.200E+00	1.250E+00
1.317E+00	1.356E+00	1.400E+00	1.500E+00	1.850E+00
2.354E+00	2.479E+00	3.000E+00	4.304E+00	4.800E+00
6.434E+00	8.187E+00	1.000E+01	1.284E+01	1.384E+01
1.455E+01	1.568E+01	1.733E+01	2.000E+01	
si3	h 0 381.00			
m2	8016.50c	-1.0		
m8	13027.50c	-0.048	\$ Concrete	
	14000.50c	-0.315		
	8016.50c	-0.500		
	1001.50c	-0.006		
	11023.50c	-0.017		
	20000.50c	-0.083		
	26000.55c	-0.012		
	19000.50c	-0.019		
mt8	lwtr.01t			
imp:n 1	206r 0			
c fuel enrichment	4.0 %			
m1	92235.50c	-0.03526		
	92238.50c	-0.84624		
	8016.50c	-0.11850		
c	end of file			
c				

HOLTEC INTERNATIONAL COPYRIGHTED MATERIAL

HI-STORM FSAR

Rev. 1

REPORT HI-2002444

Appendix 6.D-29

HI-STORM Storage Cask containing MPC68, 08x08 assembly @ 4.2 wt% Enrich.
 c MPC68 reflected w/60cm of water, 0.0279 g/cmsq B-10 in Boral

```

c
c
1 1 -10.522 -1 u=2 $ fuel
2 2 -0.0002 1 -2 u=2 $ gap
3 2 -0.0002 2 -3 u=2 $ Zr Clad
4 2 -0.0002 3 u=2 $ water in fuel region
5 2 -0.0002 -4:5 u=3 $ water in guide tubes
6 2 -0.0002 4 -5 u=3 $ guide tubes
7 2 -0.0002 -6 +7 -8 +9 u=1 lat=1
fill= -5:4 -5:4 0:0
1 1 1 1 1 1 1 1 1 1
1 2 2 2 2 2 2 2 2 1
1 2 2 2 2 2 2 2 2 1
1 2 2 2 2 2 2 2 2 1
1 2 2 2 3 2 2 2 2 1
1 2 2 2 2 3 2 2 2 1
1 2 2 2 2 2 2 2 2 1
1 2 2 2 2 2 2 2 2 1
1 2 2 2 2 2 2 2 2 1
1 1 1 1 1 1 1 1 1 1
  
```

C BOX TYPE R

```

c
8 0 -10 11 -12 13 u=4 fill=1 (0.8128 0.8128 0)
9 3 -6.55 60 -61 62 -63 #8 u=4 $ Zr flow channel
10 2 -0.0002 64 -65 66 -67 #8 #9 u=4 $ water
11 5 -7.84 20 -23 67 -14 u=4 $ 0.075" STEEL
12 2 -0.0002 20 -23 14 -15 u=4 $ WATER POCKET
13 7 -2.7 20 -23 15 -16 u=4 $ Al CLAD
14 6 -2.66 20 -23 16 -17 u=4 $ BORAL Absorber
15 7 -2.7 20 -23 17 -18 u=4 $ Al Clad
16 2 -0.0002 20 -23 18 -118 u=4 $ Water
17 5 -7.84 118:-129:65:-66 u=4 $ Steel
18 2 -0.0002 64 -21 67 -118 u=4 $ Water
19 2 -0.0002 24 -65 67 -118 u=4 $ water
20 5 -7.84 21 -20 67 -118 u=4 $ Steel
21 5 -7.84 23 -24 67 -118 u=4 $ Steel
22 2 -0.0002 129 -64 33 -118 u=4 $ Water
c
23 5 -7.84 25 -64 30 -31 u=4 $ Steel
24 2 -0.0002 26 -25 30 -31 u=4 $ Water
25 7 -2.7 27 -26 30 -31 u=4 $ Al clad
26 6 -2.66 28 -27 30 -31 u=4 $ Boral
27 7 -2.7 29 -28 30 -31 u=4 $ Al clad
28 2 -0.0002 129 -29 30 -31 u=4 $ water
29 5 -7.84 129 -64 32 -30 u=4 $ Steel ends
30 5 -7.84 129 -64 31 -33 u=4 $ Steel ends
31 2 -0.0002 129 -64 66 -32 u=4 $ Water
  
```

c Type A box - Boral only on left side

```

c
32 0 -10 11 -12 13 u=6 fill=1 (0.8128 0.8128 0)
33 3 -6.55 60 -61 62 -63 #8 u=6 $ Zr flow channel
34 2 -0.0002 64 -65 66 -118 #8 #9 u=6 $ water
35 5 -7.84 118:-129:65:-66 u=6 $ Steel
36 2 -0.0002 129 -64 67 -118 u=6 $ Water
c
37 5 -7.84 25 -64 30 -31 u=6 $ Steel
38 2 -0.0002 26 -25 30 -31 u=6 $ Water
39 7 -2.7 27 -26 30 -31 u=6 $ Al clad
  
```

HOLTEC INTERNATIONAL COPYRIGHTED MATERIAL

HI-STORM FSAR

Rev. 1

REPORT HI-2002444

Appendix 6.D-30

```

40 6 -2.66 28 -27 30 -31 u=6 $ Boral
41 7 -2.7 29 -28 30 -31 u=6 $ Al clad
42 2 -0.0002 129 -29 30 -31 u=6 $ water
43 2 -0.0002 129 -64 33 -67 u=6 $ Water
44 5 -7.84 129 -64 32 -30 u=6 $ Steel ends
45 5 -7.84 129 -64 31 -33 u=6 $ Steel ends
46 2 -0.0002 129 -64 66 -32 u=6 $ Water
c
c Type B box - Boral on Top only
c
47 0 -10 11 -12 13 u=7 fill=1 (0.8128 0.8128 0)
48 3 -6.55 60 -61 62 -63 #8 u=7 $ Zr flow channel
49 2 -0.0002 64 -65 66 -67 #8 #9 u=7 $ water
50 5 -7.84 20 -23 67 -14 u=7 $ 0.075" STEEL
51 2 -0.0002 20 -23 14 -15 u=7 $ WATER POCKET
52 7 -2.7 20 -23 15 -16 u=7 $ Al CLAD
53 6 -2.66 20 -23 16 -17 u=7 $ BORAL Absorber
54 7 -2.7 20 -23 17 -18 u=7 $ water
55 2 -0.0002 20 -23 18 -118 u=7 $ Water
56 5 -7.84 118:-129:65:-66 u=7 $ Steel
57 2 -0.0002 64 -21 67 -118 u=7 $ Water
58 2 -0.0002 24 -65 67 -118 u=7 $ water
59 5 -7.84 21 -20 67 -118 u=7 $ Steel
60 5 -7.84 23 -24 67 -118 u=7 $ Steel
61 2 -0.0002 129 -64 66 -118 u=7 $ Water
c
c Type E box - No Boral Panels
c
62 0 -10 11 -12 13 u=8 fill=1 (0.8128 0.8128 0)
63 3 -6.55 60 -61 62 -63 #8 u=8 $ Zr flow channel
64 2 -0.0002 129 -65 66 -118 #8 #9 u=8 $ water
65 5 -7.84 118:-129:65:-66 u=8 $ Steel
c
c Type F box - No Boral Panels or fuel
c
66 2 -0.0002 129 -65 66 -118 u=9 $ water
67 5 -7.84 118:-129:65:-66 u=9 $ Steel
c
68 2 -0.0002 -34 35 -36 37 u=5 lat=1 fill=-7:6 -7:6 0:0
5 5 5 5 5 5 5 5 5 5 5 5 5
5 9 9 9 9 9 9 9 9 9 9 9 9 5
5 9 9 9 9 9 7 4 9 9 9 9 9 5
5 9 9 9 7 4 4 4 4 4 9 9 9 5
5 9 9 7 4 4 4 4 4 4 4 9 9 5
5 9 9 7 4 4 4 4 4 4 4 4 9 9 5
5 9 7 4 4 4 4 4 4 4 4 4 9 5
5 9 8 4 4 4 4 4 4 4 4 4 6 9 5
5 9 9 7 4 4 4 4 4 4 4 4 9 9 5
5 9 9 8 4 4 4 4 4 4 4 6 9 9 5
5 9 9 9 8 4 4 4 6 6 9 9 9 5
5 9 9 9 9 9 8 6 9 9 9 9 9 5
5 9 9 9 9 9 9 9 9 9 9 9 9 5
5 5 5 5 5 5 5 5 5 5 5 5 5
69 0 -41 50 -49 fill=5 (8.1661 8.1661 0)
c
274 2 -0.0002 -41 360 -50 $ space below Fuel (7.3 in.)
275 5 -7.84 -42 362 -360 $ MPC Steel below Fuel (2.5 in.)
276 5 -7.84 -204 300 -362 $ Cask Steel (5.0 in.)
277 8 -2.35 -204 301 -300 $ Cask Concrete (17.0 in.)
278 5 -7.84 -204 302 -301 $ Cask Steel (2.0 in.)
c
279 2 -0.0002 -41 49 -361 $ space above Fuel (8.46 in.)

```

HOLTEC INTERNATIONAL COPYRIGHTED MATERIAL

HI-STORM FSAR
REPORT HI-2002444

Appendix 6.D-31

Rev. 1

280	5	-7.84	-42	361	-363	\$ MPC Steel above Fuel (10.0 in)
281	4	-1.00	-42	363	-400	\$ Water (1.0 in.)
282	5	-7.84	-204	400	-401	\$ Cask Steel (1.25 in.)
283	8	-2.35	-204	401	-402	\$ Cask Concrete (10.5 in.)
284	5	-7.84	-204	402	-403	\$ Cask Steel (4.0 in.)
c						
290	5	-7.84	41	-42	360	-361 \$ Radial Steel - MPC shell
291	4	-1.00	42	-200	362	-400 \$ Radial Water
292	5	-7.84	200	-201	362	-400 \$ Radial Steel - overpack inner shell
293	5	-7.84	201	-202	362	-400 \$ Radial Steel -
294	8	-2.35	202	-203	362	-400 \$ Radial Shield - Concrete Overpack
295	5	-7.84	203	-204	362	-400 \$ Radial Steel - overpack outer shell
c						
500	4	-1.00	500	-501	-505	(204 :-302: 403) \$ outer water reflector
501	0		505	:-500:	501	\$ outside world
1	cz	0.5283				\$ Fuel OD
2	cz	0.5398				\$ Clad ID
3	cz	0.6134				\$ Clad OD
4	cz	0.6744				\$ Thimble ID
5	cz	0.7506				\$ Thimble OD
6	px	0.8128				\$ Pin Pitch
7	px	-0.8128				
8	py	0.8128				
9	py	-0.8128				
10	px	6.6231				\$ Channel ID
11	px	-6.6231				
12	py	6.6231				
13	py	-6.6231				
14	py	7.8016				
15	py	7.8155				
16	py	7.8410				
17	py	8.0467				
18	py	8.0721				
118	py	8.0861				
20	px	-6.0325				
21	px	-6.2230				
23	px	6.0325				
24	px	6.2230				
25	px	-7.8016				
26	px	-7.8155				
27	px	-7.8410				
28	px	-8.0467				
29	px	-8.0721				
129	px	-8.0861				
30	py	-6.0325				
31	py	6.0325				
32	py	-6.2230				
33	py	6.2230				
34	px	7.6111				
35	px	-8.7211				
36	py	8.7211				
37	py	-7.6111				
49	pz	381.				\$ Top of Active Fuel
50	pz	0				\$ Start of Active Fuel
60	px	-6.9279				\$ Channel OD
61	px	6.9279				
62	py	-6.9279				
63	py	6.9279				
64	px	-7.6111				\$ Cell Box ID
65	px	7.6111				
66	py	-7.6111				

HOLTEC INTERNATIONAL COPYRIGHTED MATERIAL

HI-STORM FSAR

Rev. 1

REPORT HI-2002444

Appendix 6.D-32

```

67 py 7.6111
360 pz -18.54 $ lower thkness = 7.30 in.
361 pz 402.49 $ upper thkness = 8.46 in.
362 pz -24.892 $ thkness of MPC baseplate = 2.5 in.
363 pz 427.89 $ thkness of MPC lid = 10. in.
41 cz 85.57 $ I.D. = 67.375 in.
42 cz 86.84 $ I.D. = 68.375 in.
200 cz 93.35 $ I.D. = 73.50 in.
201 cz 96.52 $ I.D. = 76.00 in.
202 cz 98.43 $ I.D. = 77.50 in.
203 cz 166.37 $ I.D. = 131.00 in.
204 cz 168.28 $ I.D. = 132.50 in.
300 pz -37.59 $ thkness steel - 5.0 in.
301 pz -80.77 $ thkness concrete - 17.0 in.
302 pz -85.85 $ thkness steel - 2.0 in.
400 pz 430.43 $ thkness water - 1.0 in.
401 pz 433.605 $ thkness steel - 1.25 in.
402 pz 460.28 $ thkness concrete - 10.5 in.
403 pz 465.355 $ thkness steel - 4.0 in.

```

```

c
*500 pz -115.85 $ lower boundary
*501 pz 495.355 $ upper boundary
*505 cz 198.28 $ outer radial boundary

```

```

imp:n 1 86r 0
kcode 10000 0.94 20 120
c
sdef par=1 erg=d1 axs=0 0 1 x=d4 y=fx d5 z=d3
c

```

```

sp1 -2 1.2895
c
si3 h 0 381.
sp3 0 1
c
c
si4 s 15 16
13 14 15 16 17 18
12 13 14 15 16 17 18 19
12 13 14 15 16 17 18 19
11 12 13 14 15 16 17 18 19 20
11 12 13 14 15 16 17 18 19 20
12 13 14 15 16 17 18 19
12 13 14 15 16 17 18 19
13 14 15 16 17 18
15 16

```

```

sp4 1 67r
c
ds5 s 30 30
29 29 29 29 29 29 29
28 28 28 28 28 28 28 28
27 27 27 27 27 27 27 27
26 26 26 26 26 26 26 26 26
25 25 25 25 25 25 25 25 25
24 24 24 24 24 24 24 24
23 23 23 23 23 23 23 23
22 22 22 22 22 22
21 21

```

```

c
si11 -80.6831 -67.6783
si12 -64.1985 -51.1937
si13 -47.7139 -34.7091
si14 -31.2293 -18.2245

```

HOLTEC INTERNATIONAL COPYRIGHTED MATERIAL

HI-STORM FSAR

Rev. 1

REPORT HI-2002444

Appendix 6.D-33

si15	-14.7447	-1.7399	
si16	1.7399	14.7447	
si17	18.2245	31.2293	
si18	34.7091	47.7139	
si19	51.1937	64.1985	
si20	67.6783	80.6831	
c			
si21	-80.6831	-67.6783	
si22	-64.1985	-51.1937	
si23	-47.7139	-34.7091	
si24	-31.2293	-18.2245	
si25	-14.7447	-1.7399	
si26	1.7399	14.7447	
si27	18.2245	31.2293	
si28	34.7091	47.7139	
si29	51.1937	64.1985	
si30	67.6783	80.6831	
sp11	0	1	
sp12	0	1	
sp13	0	1	
sp14	0	1	
sp15	0	1	
sp16	0	1	
sp17	0	1	
sp18	0	1	
sp19	0	1	
sp20	0	1	
sp21	0	1	
sp22	0	1	
sp23	0	1	
sp24	0	1	
sp25	0	1	
sp26	0	1	
sp27	0	1	
sp28	0	1	
sp29	0	1	
sp30	0	1	
c			
m1	92235.50c	-0.03702	\$ 4.20% E Fuel
	92238.50c	-0.84448	
	8016.50c	-0.1185	
m2	8016.50c	1.	\$ Void
m3	40000.56c	1.	\$ Zr Clad
m4	1001.50c	0.6667	\$ Water
	8016.50c	0.3333	
m5	24000.50c	0.01761	\$ Steel
	25055.50c	0.001761	
	26000.55c	0.05977	
	28000.50c	0.008239	
m6	5010.50c	8.0707E-03	\$ Boral
	5011.50c	3.2553E-02	
	6000.50c	1.0146E-02	
	13027.50c	3.8054E-02	
m7	13027.50c	1.	\$ Al Clad
m8	13027.50c	-0.0048	\$ Concrete
	14000.50c	-0.315	
	8016.50c	-0.500	
	1001.50c	-0.006	
	11023.50c	-0.017	
	20000.50c	-0.083	
	26000.55c	-0.012	
	19000.50c	-0.019	

HOLTEC INTERNATIONAL COPYRIGHTED MATERIAL

HI-STORM FSAR

Rev. 1

REPORT HI-2002444

Appendix 6.D-34

```

mt4          lwtr.01t
mt8          lwtr.01t
prtmp       j    -60   j    2
fm4         1000   1    -6
f4:n        1
sd4         1000
e4          1.000E-11  1.000E-10  5.000E-10  7.500E-10  1.000E-09  1.200E-09
           1.500E-09  2.000E-09  2.500E-09  3.000E-09
           4.700E-09  5.000E-09  7.500E-09  1.000E-08  2.530E-08
           3.000E-08  4.000E-08  5.000E-08  6.000E-08  7.000E-08
           8.000E-08  9.000E-08  1.000E-07  1.250E-07  1.500E-07
           1.750E-07  2.000E-07  2.250E-07  2.500E-07  2.750E-07
           3.000E-07  3.250E-07  3.500E-07  3.750E-07  4.000E-07
           4.500E-07  5.000E-07  5.500E-07  6.000E-07  6.250E-07
           6.500E-07  7.000E-07  7.500E-07  8.000E-07  8.500E-07
           9.000E-07  9.250E-07  9.500E-07  9.750E-07  1.000E-06
           1.010E-06  1.020E-06  1.030E-06  1.040E-06  1.050E-06
           1.060E-06  1.070E-06  1.080E-06  1.090E-06  1.100E-06
           1.110E-06  1.120E-06  1.130E-06  1.140E-06  1.150E-06
           1.175E-06  1.200E-06  1.225E-06  1.250E-06  1.300E-06
           1.350E-06  1.400E-06  1.450E-06  1.500E-06  1.590E-06
           1.680E-06  1.770E-06  1.860E-06  1.940E-06  2.000E-06
           2.120E-06  2.210E-06  2.300E-06  2.380E-06  2.470E-06
           2.570E-06  2.670E-06  2.770E-06  2.870E-06  2.970E-06
           3.000E-06  3.050E-06  3.150E-06  3.500E-06  3.730E-06
           4.000E-06  4.750E-06  5.000E-06  5.400E-06  6.000E-06
           6.250E-06  6.500E-06  6.750E-06  7.000E-06  7.150E-06
           8.100E-06  9.100E-06  1.000E-05  1.150E-05  1.190E-05
           1.290E-05  1.375E-05  1.440E-05  1.510E-05  1.600E-05
           1.700E-05  1.850E-05  1.900E-05  2.000E-05  2.100E-05
           2.250E-05  2.500E-05  2.750E-05  3.000E-05  3.125E-05
           3.175E-05  3.325E-05  3.375E-05  3.460E-05  3.550E-05
           3.700E-05  3.800E-05  3.910E-05  3.960E-05  4.100E-05
           4.240E-05  4.400E-05  4.520E-05  4.700E-05  4.830E-05
           4.920E-05  5.060E-05  5.200E-05  5.340E-05  5.900E-05
           6.100E-05  6.500E-05  6.750E-05  7.200E-05  7.600E-05
           8.000E-05  8.200E-05  9.000E-05  1.000E-04  1.080E-04
           1.150E-04  1.190E-04  1.220E-04  1.860E-04  1.925E-04
           2.075E-04  2.100E-04  2.400E-04  2.850E-04  3.050E-04
           5.500E-04  6.700E-04  6.830E-04  9.500E-04  1.150E-03
           1.500E-03  1.550E-03  1.800E-03  2.200E-03  2.290E-03
           2.580E-03  3.000E-03  3.740E-03  3.900E-03  6.000E-03
           8.030E-03  9.500E-03  1.300E-02  1.700E-02  2.500E-02
           3.000E-02  4.500E-02  5.000E-02  5.200E-02  6.000E-02
           7.300E-02  7.500E-02  8.200E-02  8.500E-02  1.000E-01
           1.283E-01  1.500E-01  2.000E-01  2.700E-01  3.300E-01
           4.000E-01  4.200E-01  4.400E-01  4.700E-01  4.995E-01
           5.500E-01  5.730E-01  6.000E-01  6.700E-01  6.790E-01
           7.500E-01  8.200E-01  8.611E-01  8.750E-01  9.000E-01
           9.200E-01  1.010E+00  1.100E+00  1.200E+00  1.250E+00
           1.317E+00  1.356E+00  1.400E+00  1.500E+00  1.850E+00
           2.354E+00  2.479E+00  3.000E+00  4.304E+00  4.800E+00
           6.434E+00  8.187E+00  1.000E+01  1.284E+01  1.384E+01
           1.455E+01  1.568E+01  1.733E+01  2.000E+01

```

HOLTEC INTERNATIONAL COPYRIGHTED MATERIAL

HI-STORM FSAR
REPORT HI-2002444

Rev. 1

Appendix 6.D-35

SUPPLEMENT 6.I

CRITICALITY EVALUATION OF THE HI-STORM 100U SYSTEM

6.I.0 INTRODUCTION

This supplement is solely focused on providing an evaluation of criticality safety of the HI-STORM 100U system. The evaluation presented herein supplements those evaluations of the HI-STORM 100 overpack contained in the main body of Chapter 6 of this FSAR.

6.I.1 ACCEPTANCE CRITERIA

The acceptance criteria for criticality evaluations for the HI-STORM 100U system are identical to the criteria for the HI-STORM 100 system analyzed in the main body of Chapter 6.

6.I.2 EVALUATION

The HI-STORM 100U system differs from the HI-STORM 100 system only in the use of a different storage overpack, the HI-STORM 100U vertical ventilated module (VVM). All MPCs and HI-TRAC transfer casks are identical between the two systems.

The limiting condition in the main body of Chapter 6 of this FSAR is the fully flooded MPC in a HI-TRAC. This limiting condition is unaffected by the different storage overpacks. All results and conclusions for the fully flooded condition from the main body of Chapter 6 are therefore directly applicable to the HI-STORM 100U system.

During storage conditions, the maximum k_{eff} is significantly below the limiting maximum k_{eff} since the MPC is internally dry (see Section 6.1). Under this condition, the configuration is very similar between the HI-STORM 100U VVM and the HI-STORM 100 overpack analyzed in the main body of Chapter 6, consisting of the internally dry MPC, the gap between the MPC and the overpack, a steel shell or shells and concrete (above-ground) or soil (below-ground). Results for the VVM would therefore be practically identical to the results listed for storage conditions in the main body of Chapter 6. Any small differences in results would not affect the principal conclusions, since the maximum k_{eff} under storage conditions is so low.

In summary, the limiting condition for the HI-STORM 100U is identical to the limiting condition for the HI-STORM 100, and other conditions are very similar between the two systems from a criticality perspective. All results and conclusions for the HI-STORM 100 system presented in the main body of Chapter 6 are therefore directly applicable to the HI-STORM 100U system, and no additional calculations to demonstrate criticality safety are required for the HI-STORM 100U system.

HOLTEC INTERNATIONAL COPYRIGHTED MATERIAL

SUPPLEMENT 6.III¹: CRITICALITY EVALUATION OF THE MPC-68M

6.III.1 DISCUSSION AND RESULTS

In conformance with the principles established in NUREG-1536 [6.III.1.1], 10CFR72.124 [6.III.1.2], and NUREG-0800 Section 9.1.2 [6.III.1.3], the results in this supplement demonstrate that the effective multiplication factor (k_{eff}) of the HI-STORM 100 System with the MPC-68M, including all biases and uncertainties evaluated with a 95% probability at the 95% confidence level, does not exceed 0.95 under all credible normal, off-normal, and accident conditions.

Criticality safety of the HI-STORM 100 System with the MPC-68M depends on the following principal design parameters:

- The inherent geometry of the fuel basket design of the MPC-68M;
- The incorporation of spatially distributed B-10 isotope in the Metamic-HT fuel basket structure. Based on the tests for the neutron absorber content in Metamic-HT (see Appendix 1.III.A and Supplement 9.III), and consistent with the approach taken for Metamic (see Section 9.1.5.3.2), 90% of the minimum B-10 (B_4C) content is credited in the analysis. With a specified minimum B_4C content of 10 wt%, the concentration credited in the analysis is therefore 9 wt%.

The off-normal and accident conditions defined in Section 2.2 are applicable to the HI-STORM System using the MPC-68M. These accidents are considered in Supplement 11.III and have no adverse effect on the design parameters important to criticality safety, except for the non-mechanistic tip-over event, which could result in limited plastic deformation of the basket. However, a bounding basket deformation is already included in the criticality models for normal conditions, and thus, from the criticality safety standpoint, the off-normal and accident conditions are identical to those for normal conditions.

Results of the design basis criticality safety calculations for a single internally flooded HI-TRAC transfer cask with full water reflection on all sides (limiting cases for the HI-STORM 100 System), loaded with intact fuel assemblies are listed in Table 6.III.1.1, conservatively evaluated for the worst combination of manufacturing tolerances (as identified in Section 6.III.3), and including the calculational bias, uncertainties, and calculational statistics. In addition, a result for a single internally dry (no moderator) HI-STORM storage cask with full water reflection on all external surfaces of the overpack, including the annulus region between the MPC and overpack, is listed in Table 6.III.1.2 to confirm the low reactivity of the HI-STORM 100 System with an MPC-68M in storage. The maximum k_{eff} for an MPC-68M loaded with up to 16 DFCs is listed in Table 6.III.1.3.

¹ Evaluations and results presented in this chapter are supported by documented calculation package(s) [6.III.1.4].

TABLE 6.III.1.1

BOUNDING MAXIMUM k_{eff} VALUES FOR EACH ASSEMBLY CLASS IN THE MPC-68M
(HI-TRAC 100)

Fuel Assembly Class	Maximum Allowable Planar-Average Enrichment (wt% U-235)	Maximum k_{eff}
7x7B	4.8	0.9243
8x8B	4.8	0.9294
8x8C	4.8	0.9302
8x8D	4.8	0.9307
8x8E	4.8	0.9211
8x8F	4.5	0.9245
9x9A	4.8	0.9341
9x9B	4.8	0.9330
9x9C	4.8	0.9254
9x9D	4.8	0.9254
9x9E/F	4.5	0.9254
9x9G	4.8	0.9211
10x10A	4.8	0.9360
10x10B	4.8	0.9353
10x10C	4.8	0.9321
10x10F	4.7	0.9356
10x10G	4.6	0.9393

Note: The results presented in the table above have an additional bias of 0.0021 applied to the 10x10 fuel assembly classes to conservatively account for any potential distributed enrichment effects. See Section 6.III.2.

HOLTEC INTERNATIONAL COPYRIGHTED MATERIAL

HI-STORM 100 FSAR
REPORT HI-2002444

6.III-2

Rev. 11

TABLE 6.III.1.2

REPRESENTATIVE k_{eff} VALUES FOR MPC-68M IN THE HI-STORM 100 OVERPACK

Fuel Assembly Class	Maximum Allowable Planar-Average Enrichment (wt% ^{235}U)	Maximum k_{eff}
10x10A	4.8	0.3754

TABLE 6.III.1.3

BOUNDING MAXIMUM k_{eff} VALUES FOR THE MPC-68M WITH UP TO 16 DFCs

Fuel Assembly Class	Maximum Allowable Planar-Average Enrichment (wt% ^{235}U)	Maximum k_{eff}
All BWR Classes except 8x8F, 9x9E/F, 10x10F and 10x10G	4.8	0.9408
8x8F, 9x9E/F and 10x10G	4.0	0.9131
10x10F	4.6	0.9362

Note: The results presented in Tables 6.III.1.2 and 6.III.1.3 above have an additional bias of 0.0021 applied to the 10x10 fuel assembly classes to conservatively account for any potential distributed enrichment effects. See Section 6.III.2.

HOLTEC INTERNATIONAL COPYRIGHTED MATERIAL

6.III.2 SPENT FUEL LOADING

The BWR fuel assembly classes/arrays which are authorized for the MPC-68 are qualified for the MPC-68M, except for the 6x6A, 6x6B, 6x6C, 7x7A, 8x8A, 10x10D and 10x10E. Additionally, the MPC-68M is qualified for two new assembly classes, 10x10F and 10x10G. Information on those classes is provided in Supplement 2.III, Table 2.III.3. Table 2.1.4 in Chapter 2 provides the acceptable fuel characteristics for all other fuel array/class authorized for storage in the MPC-68M, however fuel with planar-average initial enrichments up to 4.8 wt% ^{235}U are authorized in the MPC-68M.

BWR assemblies are specified in the Table 2.1.4 and Table 2.III.3 with a maximum planar-average enrichment. The analyses presented in this chapter use a uniform enrichment, equal to the maximum planar-average. Analyses presented in Appendix 6.B for the MPC-68 show that this is a conservative approach, i.e. that a uniform enrichment bounds the planar-average enrichment in terms of the maximum k_{eff} . To confirm this for the higher enrichments analyzed here, additional calculations were performed for the assembly class 10x10A in the MPC-68M, and are presented in Table 6.III.2.1 in comparison with the results for the uniform enrichment. Since the maximum planar-average enrichment of 4.8 wt% ^{235}U is above the actual enrichments of those assemblies, actual (as-built) enrichment distributions are not available. Therefore, several bounding cases are analyzed. Note that since the maximum planar-average enrichment of 4.8 wt% ^{235}U is close to the maximum rod enrichment of 5.0 wt% ^{235}U , the potential enrichment variations within the cross section are somewhat limited. To maximize the differences in enrichment under these conditions, the analyzed cases assume that about 50% of the rods in the cross section are at an enrichment of 5.0 wt% ^{235}U , while the remainder of the rods are at an enrichment of about 4.6 wt%, resulting in an average of 4.8 wt%. Calculations are performed for cross sections where all full-length and part-length, or only all full-length rods are present. For each case, two conditions are analyzed that places the different enrichment in areas with different local fuel-to-water ratios. Specifically, one condition places the higher enriched rods in locations where they are more surrounded by other rods, whereas the other condition places them in locations where they are more surrounded by water, such as near the water-rods or the periphery of the assembly. The results in Table 6.III.2.1 indicate that there may be a potential positive reactivity effect (+0.0021) due to distributed enrichments. Therefore, additional studies with distributed enrichments were performed and are presented in Table 6.III.2.2. These include all cases from Appendix B (for 8x8 and 9x9 assembly types), now evaluated in the MPC-68M, and additional cases for the 10x10G which has the highest reactivity of all assembly classes. The cases from Appendix B show no statistically significant increase, and in most cases a decrease in reactivity as a result of the distributed enrichment. However, the assembly class 10x10G also shows a slight increase for one of the cases (+0.0012). Note that the small positive reactivity effect for the two 10x10 assembly classes is likely due to the very conservative selection of enriched rod locations used in the study (in the study they were placed close to the periphery and water rods, locations that are unlikely for actual fuel assemblies but were selected for the study to cover unknown rod patterns). Nevertheless, for conservatism an additional bias of 0.0021 is applied to the results for all 10x10 fuel assembly classes in Section 6.III.1, including the cases with damaged fuel. Note that for the studies presented in the remainder of this supplement this bias is not included since those studies focus on reactivity differences rather than absolute values of k_{eff} .

HOLTEC INTERNATIONAL COPYRIGHTED MATERIAL

HI-STORM 100 FSAR
REPORT HI-2002444

6.III-4

Rev. 11

TABLE 6.III.2.1

REACTIVITY EFFECT OF DISTRIBUTED ENRICHMENTS IN BWR FUEL IN THE MPC-68M

Fuel Assembly/ Parameter Variation	reactivity effect	Maximum k_{eff}	standard deviation
10x10A (Reference, full-length rods only)	Reference	0.9339	0.0004
distributed enrichment, Case 1	-0.0004	0.9335	0.0004
distributed enrichment, Case 2	+0.0021	0.9360	0.0004
distributed enrichment, Case 3	-0.0092	0.9247	0.0004
distributed enrichment, Case 4	-0.0118	0.9221	0.0004

HOLTEC INTERNATIONAL COPYRIGHTED MATERIAL

HI-STORM 100 FSAR
REPORT HI-2002444

6.III-5

Rev. 11

TABLE 6.III.2.2

ADDITIONAL CALCULATIONS OF THE REACTIVITY EFFECT OF DISTRIBUTED
ENRICHMENTS IN BWR FUEL IN THE MPC-68M

Assembly Class	Enrichment	Maximum k_{eff}	Description	Delta- k_{eff}
8x8C	4.8	0.8273	Average Enrichment	-0.0044
8x8C	4.8	0.8229	Distributed Enrichment	
8x8C	4.8	0.8876	Average Enrichment	-0.0040
8x8C	4.8	0.8836	Distributed Enrichment	
8x8D	4.8	0.8550	Average Enrichment	+0.0004
8x8D	4.8	0.8554	Distributed Enrichment	
8x8D	4.8	0.8774	Average Enrichment	-0.0017
8x8D	4.8	0.8757	Distributed Enrichment	
8x8D	4.8	0.8855	Average Enrichment	-0.0026
8x8D	4.8	0.8829	Distributed Enrichment	
9x9B	4.8	0.9103	Average Enrichment	-0.0023
9x9B	4.8	0.9080	Distributed Enrichment	
9x9D	4.8	0.8467	Average Enrichment	-0.0095
9x9D	4.8	0.8372	Distributed Enrichment	
8x8C	4.8	0.9023	Average Enrichment	-0.0025
8x8C	4.8	0.8998	Distributed Enrichment	
8x8C	4.8	0.9165	Average Enrichment	-0.0003
8x8C	4.8	0.9162	Distributed Enrichment	
10x10G	4.6	0.9372	Average Enrichment	-0.0233
10x10G	4.6	0.9139	Distributed Enrichment	
10x10G	4.6	0.9372	Average Enrichment	-0.0285
10x10G	4.6	0.9087	Distributed Enrichment	
10x10G	4.6	0.9372	Average Enrichment	+0.0012
10x10G	4.6	0.9384	Distributed Enrichment	
10x10G	4.6	0.9372	Average Enrichment	-0.0014
10x10G	4.6	0.9358	Distributed Enrichment	

HOLTEC INTERNATIONAL COPYRIGHTED MATERIAL

HI-STORM 100 FSAR
REPORT HI-2002444

6.III-6

Rev. 11

6.III.3 MODEL SPECIFICATION

Calculational models for the MPC-68M are generally the same as those described in Section 6.3 except for the different basket as noted below.

Figures 6.III.3.1 and 6.III.3.2 show representative cross sections of the criticality models for the MPC-68M basket. Figure 6.III.3.1 shows a single cell of the basket, while Figure 6.III.3.2 shows the entire MPC-68M basket. All calculations are performed with eccentric fuel positioning, where the fuel is placed closest to the center of the basket in each basket cell. The wall thickness of the basket shims is modeled as 1 inch, while some of them are only ½ inch thick. This is conservative, since the model replaces water with aluminum, which reduces absorption and moderation outside of the basket.

To account for the potentially higher fuel density of higher enriched fuel, a conservative fuel stack density of 97.5% of the theoretical density (i.e. $10.96 \text{ g/cm}^3 * 97.5\% = 10.686 \text{ g/cm}^3$) is used in all analyses for the MPC-68M.

The basket geometry can vary due to manufacturing tolerances and due to potential deflections of basket walls as the result of accident conditions. The basket tolerances are defined on the drawings in Section 1.5. The structural acceptance criterion for the basket during accident conditions is that the permanent deflection of the basket panels is limited to a fraction of 0.005 (0.5%) of the panel width (see Chapter 3). The analyses in Supplement 3.III demonstrate that permanent deformations of the basket walls during accident conditions are far below this limit. Nevertheless, it is conservatively assumed that 2 adjacent cell walls in each cell are deflected to the maximum extent possible over their entire length and width, i.e. that the cell ID is reduced by 0.5% of the cell width, or 0.03" for MPC-68M cells. Maximum k_{eff} results (including the bias, uncertainties, or calculational statistics), along with the selected dimensions, for a number of dimensional combinations are shown in Table 6.III.3.1 for various fuel types. The cell ID is evaluated for minimum (tolerance only), minimum with deformation, nominal and an increased value. The wall thickness is evaluated for nominal and minimum values.

Based on the calculations, the conservative dimensional assumptions listed in Table 6.III.3.2 were determined for the basket designs. Note that, as expected, the bounding basket condition correspond to the minimum wall thickness and minimum cell-id. Because the reactivity effect (positive or negative) of the manufacturing tolerances is not assembly dependent (see Table 6.III.3.1), these dimensional assumptions were employed for all criticality analyses.

The basket is manufactured from individual slotted panels. The panels are expected to be in direct contact with each other (see Drawing in Section 1.5). However, to show that small gaps between panels would have essentially no effect on criticality, calculations are performed with a postulated 0.06" gap between panels, repeated in the axial direction every 10" in all panels. The results are summarized in Tables 6.III.3.3 and show statistically equivalent results for calculations with and without the gap. This indicates that the effect of small gaps between the METAMIC panels is negligible. Therefore, all other calculations are performed without any gaps between panels.

HOLTEC INTERNATIONAL COPYRIGHTED MATERIAL

The MPC-68M uses the same principal neutron poison material as the MPC-68 (i.e. ^{10}B in the form of B_4C). The evaluation provided in Section 6.3.2, which concludes that ^{10}B depletion is negligible, is therefore directly applicable to the MPC-68M, and no additional evaluations are required in that respect.

Composition of the Metamic-HT is listed in Table 6.III.3.4.

HOLTEC INTERNATIONAL COPYRIGHTED MATERIAL

HI-STORM 100 FSAR
REPORT HI-2002444

6.III-8

Rev. 11

TABLE 6.III.3.1

EVALUATION OF BASKET MANUFACTURING TOLERANCES FOR MPC-68M

Box I.D.	Box Wall Thickness	Maximum keff
10x10A, 4.8% Enrichment		
nominal (6.05")	nominal (0.40")	0.9263
nominal (6.05")	minimum (0.38")	0.9307
increased (6.07")	minimum (0.38")	0.9288
minimum (5.99")	minimum (0.38")	0.9334
minimum, including deformation (5.96")	minimum (0.38")	0.9339
7x7B, 4.8% Enrichment		
nominal (6.05")	nominal (0.40")	0.9154
nominal (6.05")	minimum (0.38")	0.9196
minimum, including deformation (5.96")	minimum (0.38")	0.9243
8x8D, 4.8% Enrichment		
nominal (6.05")	nominal (0.40")	0.9230
nominal (6.05")	minimum (0.38")	0.9265
minimum, including deformation (5.96")	minimum (0.38")	0.9307
9x9A, 4.8% Enrichment		
nominal (6.05")	nominal (0.40")	0.9263
nominal (6.05")	minimum (0.38")	0.9301
minimum, including deformation (5.96")	minimum (0.38")	0.9341
10x10G, 4.6% Enrichment		
nominal (6.05")	nominal (0.40")	0.9314
nominal (6.05")	minimum (0.38")	0.9349
minimum, including deformation (5.96")	minimum (0.38")	0.9372
10x10A, 4.8% Enrichment, Damaged Fuel		
nominal (6.05")	nominal (0.40")	0.9316
nominal (6.05")	minimum (0.38")	0.9348
minimum, including deformation (5.96")	minimum (0.38")	0.9387

Note: The results for the 10x10 fuel assembly classes do not include the bias for distributed enrichments discussed in Section 6.III.2.

HOLTEC INTERNATIONAL COPYRIGHTED MATERIAL

HI-STORM 100 FSAR
REPORT HI-2002444

6.III-9

Rev. 11

TABLE 6.III.3.2

MPC-68M BASKET DIMENSIONAL ASSUMPTIONS

Box I.D.	Box Wall Thickness
minimum, including deformation (5.96")	minimum (0.38")

TABLE 6.III.3.3

REACTIVITY EFFECTS GAPS IN BASKET CELL PLATES

Gaps in Metamic-HT	MPC-68M (10x10A, 4.8% ENRICHMENT)	
	Max. k_{eff}	1 Sigma
None	0.9339	0.0004
0.06" every 10"	0.9346	0.0003

Note: The results do not include the bias for distributed enrichments discussed in Section 6.III.2.

TABLE 6.III.3.4

COMPOSITION OF THE METAMIC-HT

METAMIC HT, 9% B₄C, DENSITY 2.6 g/cm³	
Nuclide	Wgt. Fraction
13027	0.91
6000	0.01956
5010	0.01289
5011	0.05755

HOLTEC INTERNATIONAL COPYRIGHTED MATERIAL

HI-STORM 100 FSAR
 REPORT HI-2002444

6.III-12

Rev. 11

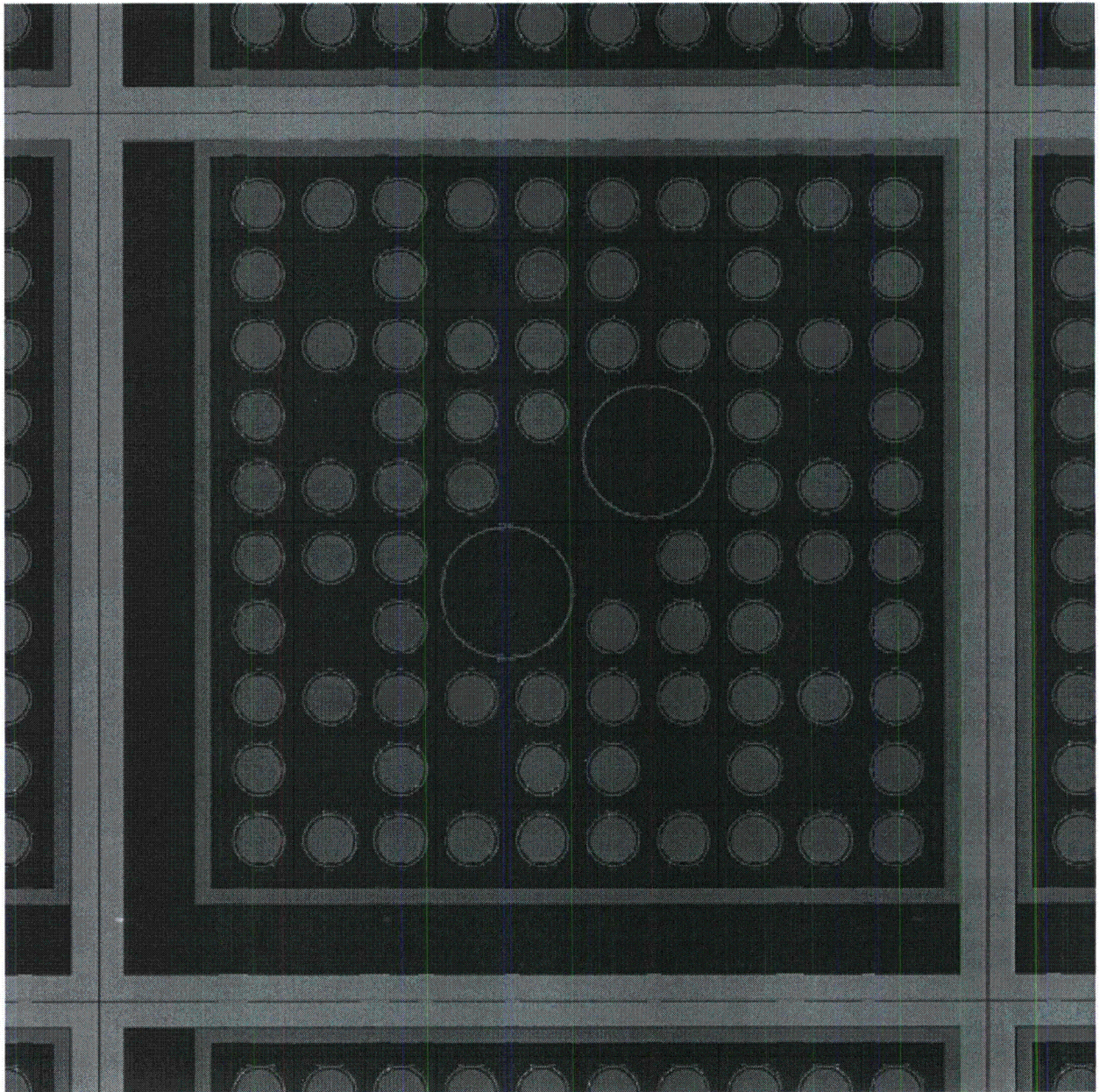


Figure generated directly from MCNP input file using the MCNP plot function. For Cell ID and Cell Wall Thickness see Table 6.III.3.2. For true dimensions see the drawing in Section 1.5. Note that the figure depicts an assembly with full and part length rods, showing the cross section where only full length rods are present.

Figure 6.III.3.1: Typical Cell of the Calculational Model (planar cross-section) with representative fuel in the MPC-68M

HOLTEC INTERNATIONAL COPYRIGHTED MATERIAL

HI-STORM 100 FSAR
REPORT HI-2002444

6.III-13

Rev. 11

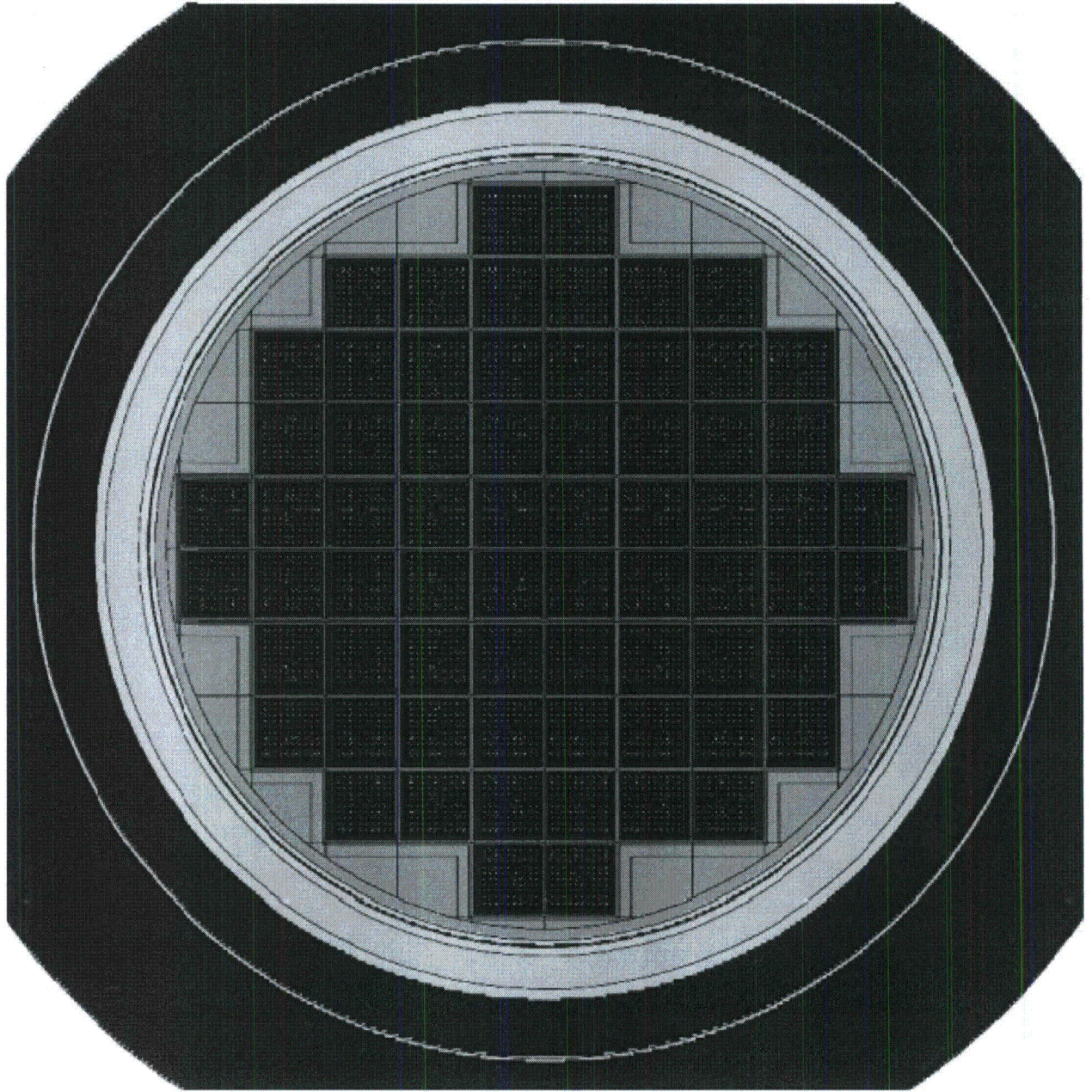


Figure generated directly from MCNP input file using the MCNP plot function. Radial dimensions of the HI-TRAC used in the analyses are unchanged from the analyses in the main part of this chapter. For true dimensions see the drawings in Section 1.5.

Figure 6.III.3.2: Calculational Model (planar cross-section) of the MPC-68M

6.III.4 CRITICALITY CALCULATIONS

The calculations in this supplement use the same computer codes and methodologies that are used in the main part of Chapter 6. Specifically, the conservative approach to model damaged fuel and fuel debris, using arrays of bare fuel rods, is the same (see discussion in Subsection 6.III.4.1 below).

The basket design of the MPC-68M is essentially identical to that of the MPC-68, in respect to the characteristics important to criticality safety. Specifically,

- The number and configuration of the cells for intact and damaged fuel/fuel debris are unchanged;
- The basket dimensions are essentially the same; and
- The same poison material (B_4C) is used, but a larger ^{10}B content in the basket walls.

The content is also the same, except for the following

- Higher enrichments are qualified, consistent with the higher ^{10}B content in the basket walls; and
- Two additional fuel assembly types are analyzed, that are variations of existing types with slightly different dimension.

To verify that the bounding fuel parameter variations analyzed in the MPC-68 are also applicable to the MPC-68M, additional studies are performed and discussed in Subsection 6.III.4.2 below.

Due to the strong similarity in the basket design, the conclusions of the various studies presented in the main part of this Chapter on the MPC-68 are directly applicable to the MPC-68M. Nevertheless, to confirm this is also applicable to the MPC-68M, numerous studies with various moderation conditions that conclude that the fully flooded basket is the bounding case are re-analyzed and discussed in subsection 6.III.4.3. All analyzes are therefore performed under the following condition:

- Basket, and DFCs as applicable, are fully flooded with pure water at the maximum density; and
- Pellet-to-clad gaps of intact assemblies are assumed flooded (see also discussion in Subsection 6.III.4.2 below)
- All assemblies and DFCs are located eccentrically in the basket, closest to the center of the basket.

Results for all design basis calculations are listed in Subsection 6.III.1. All maximum k_{eff} values are below the regulatory limit of 0.95.

6.III.4.1 Damaged Fuel and Fuel Debris

HOLTEC INTERNATIONAL COPYRIGHTED MATERIAL

HI-STORM 100 FSAR
REPORT HI-2002444

6.III-15

Rev. 11

For damaged fuel and fuel debris in the MPC-68M the same conservative approach is used as in the main part of this chapter, see discussion in Section 6.4.4, specifically 6.4.4.2. Important aspects of this approach that ensure its conservatism are as follows:

- All damaged fuel and fuel debris must be in damaged fuel containers (DFCs), and located in specifically designated cells on the periphery of the basket as specified in Table 2.1.22.
- A conservative model is used that bounds both damaged fuel and fuel debris. In other words, damaged fuel is always conservatively modeled as fuel debris.
- The model consists of regular arrays of fuel rods without cladding. The rods pitch (array size) is varied to determine the optimum moderation condition.
- Intact and damaged fuel/fuel debris in the same basket have the same enrichment limit, which may be different from the enrichment limit for intact fuel only.
- The results for loading with intact fuel only in Table 6.III.1.1 utilize different enrichment limits for different assembly classes, to ensure that the maximum k_{eff} is always below 0.95. It is therefore not possible to establish a single bounding assembly class/enrichment combination to be used in all analyses with damaged fuel/fuel debris. Therefore, and in order to optimize the enrichment for the loading of intact and damaged fuel/fuel debris for each assembly class, intact assemblies are grouped by enrichment limit, and the intact assembly with the highest maximum k_{eff} in each group is used for the calculations together with damaged fuel/fuel debris. These are:
 - Intact assemblies of 4.5 and 4.6 wt%: Assembly class 10x10G. For the calculations with intact and damaged fuel, an enrichment of 4.0 wt% is used.
 - Intact assembly of 4.7 wt%: Assembly class 10x10F. For the calculations with intact and damaged fuel, an enrichment of 4.6 wt% is used.
 - Intact assembly of 4.8 wt%: Assembly class 10x10A. For the calculations with intact and damaged fuel, an enrichment of 4.8 wt% is used.
- Consistent with the results in the main part of this chapter for the MPC-68, array sizes of 10x10 and 11x11 show the optimum moderation condition. This is confirmed for intact assembly classes 10x10A and 10x10G by evaluating all arrays from 3x3 to 17x17 rods. For assembly class 10x10F it is only confirmed that it is bounded by the cases with the 10x10A class (see Table 6.III.4.1).

6.III.4.2 Fuel Parameters and Parameter Variations

In the main part of the FSAR, extensive analyses of fuel dimensional variations have been performed. These calculations demonstrate that the maximum reactivity corresponds to:

- maximum active fuel length,
- maximum fuel pellet diameter,
- maximum fuel rod pitch,
- minimum cladding outside diameter (OD),
- maximum cladding inside diameter (ID),
- minimum guide tube/water rod thickness, and
- maximum channel thickness (for BWR assemblies only)

HOLTEC INTERNATIONAL COPYRIGHTED MATERIAL

- part length rods (if present) removed.

The reason that those are bounding dimensions, i.e. that they result in maximum reactivity is directly based on, and can be directly derived from the three main characteristics affecting reactivity, namely 1) characteristics of the fission process; 2) the characteristics of the fuel assemblies and 3) the characteristics of the neutron absorber in the basket. These affect the reactivity as follows:

- The neutrons generated by fission are fast neutrons while the neutrons that initiate the fission need to be thermal neutrons. A moderator (water) is therefore necessary for the nuclear chain reaction to continue.
- Fuel assemblies are predominantly characterized by the amount of fuel and the fuel-to-water (moderator) ratio. Increasing the amount of fuel, or the enrichment of the fuel, will increase the amount of fissile material, and therefore increase reactivity. Regarding the fuel-to-water ratio, it is important to note that commercial BWR assemblies are undermoderated, i.e. they do not contain enough water for a maximum possible reactivity.
- The neutron poison in the basket walls uses B-10, which is an absorber of thermal neutrons. This poison therefore also needs water (moderator) to be effective. This places a specific importance on the amount of water between the outer rows of the fuel assemblies and the basket cell walls. Note that this explains some of the differences in reactivity between the different assembly types in the same basket, even for the same enrichment, where assemblies with a smaller cross section, i.e. which have more water between the periphery of the assembly and the surrounding wall, generally have a lower reactivity.

Based on these characteristics, the following conclusions can be made:

- Since fuel assemblies are undermoderated, any changes in geometry inside the fuel assembly that increases the amount of water while maintaining the amount of fuel are expected to increase reactivity. This explains why reducing the cladding or guide tube/water rod thicknesses, or increasing the fuel rod pitch results in an increase in reactivity.
- Increasing the active length will increase the amount of fuel while maintaining the fuel-to-water ratio, and therefore increase reactivity.
- The channel of the BWR assembly is a structure located outside of the rod array. It therefore does not affect the water-to-fuel ratio within the assembly. However, it reduces the amount of water between the assembly and the neutron poison, therefore reducing the effective thermalization for the poison. Therefore, an increase of the channel wall thickness will increase reactivity.
- In respect to the effect of the fuel pellet diameter, several compensatory effects need to be considered. Increasing the diameter will tend to increase the reactivity due to the increase in the fuel amount. However, it will also change the fuel-to-water-ratio, and will therefore make the fuel more undermoderated, which in turn tends to reduce reactivity. The effect of this change in moderation may depend on the condition of the pellet-to-clad gap. Assuming an empty pellet-to clad gap, which would be consistent with undamaged fuel rods, the change in moderation is small, and the net effect is an increase in reactivity, since the effect of the increase in the fissionable material dominates. In this case, the maximum pellet diameter is more reactive. When the pellet-to-clad gap is conservatively flooded, as

HOLTEC INTERNATIONAL COPYRIGHTED MATERIAL

HI-STORM 100 FSAR
REPORT HI-2002444

6.III-17

Rev. 11

recommended by NUREG 1536, a reduction of the fuel pellet diameter will also result in an increase in the amount of water, i.e. have a double effect on the water-to-fuel ratio. In this case, it is possible that a slight reduction may result in no reduction or even an increase in reactivity. However, this is caused by a further amplification of the conservative assumption of the flooded pellet-to-clad gap, not by a positive increase in reactivity from the reduction in fuel (which would be counter-intuitive). Therefore, the maximum fuel pellet diameter is used for the fuel specification.

- Several assembly types contain part length rods (9x9A, 10x10A, B and G):
 - For 9x9A and 10x10A and B it was shown in the main part of the chapter (Tables 6.2.29, 36 and 37, respectively) that the condition with the part lengths rods completely removed is bounding. This condition is therefore used in the design basis calculations, so a specification of the lengths of the part length rods is not required. Applicability to the MPC-68M is confirmed by showing that all assemblies are undermoderated, which means the increase of water from completely removing the part length rods increases reactivity. All calculations for the MPC-68M for assembly classes 9x9A and 10x10A and B are therefore performed with models where the part length rods are replaced by water.
 - For assembly class 10x10G, the part length rods are located near the periphery and the water rod of the assembly, i.e. not surrounded by other rods on all sides. For this fuel assembly class, calculations with various part length rod lengths were performed and show that using full length rods in place of part length rods is more conservative. These calculations are listed in Table 6.III.4.4 (Note that the 75% case and the 100% case in the tables are statistically equivalent, i.e. they do not indicate that a reduced length would result in a higher reactivity). The case with all rods full length is therefore conservatively used in Table 6.III.1.1. This again removes the need to specify a length for the part lengths rods.

Since all assemblies have the same principal design, i.e. consist of bundles of clad fuel rods, most of them with embedded guide/instrument tubes or water rods or channels, the above conclusions apply to all of them, and the bounding dimensions are therefore also common to all fuel assemblies analyzed here. Nevertheless, to clearly demonstrate that the main assumption is true, i.e. that all assemblies are undermoderated, a study was performed for all assembly types where the pellet-to-clad gap is empty instead of being flooded (a conservative assumption for the design basis calculations) The results are listed in Table 6.III.4.2, in comparison with the results of the reference cases with the flooded gap. In all cases, the reactivity is reduced compared to the reference case. This verifies that all assembly types considered here are in fact undermoderated, and therefore validates the main assumption stated above. All assembly types are therefore behaving in a similar fashion, and the bounding dimensions are therefore applicable to all assembly types.

The discussion provided above regarding the principal characteristics of fuel poison is also important for the various studies presented in this section, and supports the fact that those studies only need to be performed for a single BWR assembly type, and that the results of those studies are then generally applicable to all assembly types. The studies and the relationship to the discussion above are listed below.

Basket Manufacturing Tolerance: The two aspects of the basket tolerance that are evaluated are the cell wall thickness and the cell ID. The reduced cell wall thickness results in a reduced amount of poison (since the material composition of the wall is fixed), and therefore in an increase in reactivity. The reduced cell ID reduces amount of water between the fuel the poison, and therefore the effectiveness of the poison material. Both effects are simply a function of the geometry, and are independent of the fuel type. However, calculations are performed for various fuel types and this study is presented in Table 6.III.3.1.

Panel Gaps: Similar to the basket manufacturing tolerance for the cell wall thickness, this tolerance has a small effect on the overall poison amount of the basket, which would affect the reactivity of the system independent of the fuel type. This study is presented in Table 6.III.4.5.

Eccentric positioning: When a fuel assembly is located in the center of a basket cell, it is surrounded by equal amounts of water on all sides, and hence the thermalization of the neutrons that occur between the assembly and the poison in the cell wall, and hence the effectiveness of the poison, is also equal on all sides. For an eccentric positioning, the effectiveness of the poison is now reduced on those sides where the assembly is located close to the cell walls, and increased on the opposite sides. This creates a compensatory situation for a single cell, where the net effect is not immediately clear. However, for the entire basket, and for the condition where all assemblies are located closest to the center of the basket, the four assemblies at the center of the basket are now located close to each other, separated by poison plates with a reduced effectiveness since they are not surrounded by water on any side. This now becomes the dominating condition in terms of reactivity increase. This effect is also applicable to all assembly types, since those assemblies are all located close to the center of the basket, i.e. the eccentric position with all assemblies moved towards the center will be bounding regardless of the assembly type. An additional study is presented in Table 6.III.4.6 to confirm this effect for the MPC-68M.

In addition, additional fuel assembly characteristics important to criticality control are the location of guide tubes, water rods, part length rods, and rods with differing dimensions (classes 9x9E/F only). These are identified in the assembly cross sections provided in Figure 6.III.4.1.

Various additional studies were performed to address conditions for specific assembly classes:

- Fuel assembly class 8x8B and 8x8D are specified with various fuel rod numbers and water rod locations (see Figure 6.III.4.1). Calculations are performed to show that the results listed in Table 6.III.1 are bounding. These calculations are listed in Table 6.III.4.3.
- Fuel assembly class 9x9E/F has two rod diameters, and two water rod patterns (see Figure 6.III.4.1). A study is performed and documented in Table 6.III.4.3 that shows that the result listed in Table 6.III.1 is bounding.

6.III.4.3 Moderation Conditions

Additional studies were performed to verify that the fully flooded condition is bounding for the MPC-68M, as it is for the MPC-68 basket analyzed in the main part of this chapter:

HOLTEC INTERNATIONAL COPYRIGHTED MATERIAL

HI-STORM 100 FSAR
REPORT HI-2002444

6.III-19

Rev. 11

- **Internal and External Moderation:** The studies presented in Table 6.III.4.2 show that all assemblies essentially behave identical in respect to water moderation, specifically, that all assemblies are undermoderated. The principal effect of changes to the internal and external moderation would therefore be independent of the fuel type. Calculations for the MPC-68M design with external moderators of various densities are shown in Table 6.III.4.7, all performed for the HI-TRAC and the MPC fully flooded. The results show that the maximum k_{eff} is essentially independent from the external water density. Nevertheless, all further evaluations are performed with full external water density. In a definitive study, Cano, et al. [6.4.2] have demonstrated that the phenomenon of a peak in reactivity at low moderator densities (sometimes called "optimum" moderation) does not occur in the presence of strong neutron absorbing material or in the absence of large water spaces between fuel assemblies in storage. All calculations are therefore performed with full water density inside the MPCs.
- **Partial Flooding:** The partial flooding of the basket, either in horizontal or vertical direction, reduces the amount of fuel that partakes effectively in the thermal fission process, while essentially maintaining the fuel-to-water ratio in the volume that is still flooded. This will therefore result in a reduction of the reactivity of the system (similar to that of the reduction of the active length), and due to the similarity of the fuel assemblies is not dependent on the specific fuel type. The reactivity changes during the flooding process were evaluated in both the vertical and horizontal positions for all MPC designs. For these calculations, the cask is partially filled (at various levels) with full density (1.0 g/cm^3) water and the remainder of the cask is filled with steam consisting of ordinary water at a low partial density (0.002 g/cm^3 or less), as suggested in NUREG-1536. Results of these calculations are shown in Table 6.III.4.8. In all cases, the reactivity increases monotonically as the water level rises, confirming that the most reactive condition is fully flooded. Note that the studies for partial flooding are performed with the design basis model for the assembly class 10x10A that has the partial length rods removed for added conservatism, while the calculations in the main part of the chapter for the MPC-68 were performed for an assembly class that did not include partial length rods. This shows that the conclusion from partial flooding, i.e. that the fully flooded condition is bounding, applies equally to assemblies with and without partial lengths rods.
- **Pellet-to-clad Gap Flooding:** As demonstrated by the studies shown in Table 6.III.4.2, all assemblies are undermoderated. Flooding the pellet-to-clad gap will therefore improve the moderation and therefore increase reactivity for all assembly types.
- **Preferential Flooding:** The only preferential flooding situation that may be credible is the flooding of the bottom section of the DFCs while the rest of the MPC internal cavity is already drained. In this condition, the undamaged assemblies have a negligible effect on the system reactivity since they are not flooded with water. The dominating effect is from the damaged fuel model in the DFCs. However, the damaged fuel model is conservatively based on an optimum moderated array of bare fuel rods in water, and therefore representative of all fuel types and therefore the fully flooded condition is bounding of the preferential flooding condition.

TABLE 6.III.4.1

MAXIMUM k_{eff} VALUES IN THE MPC-68M WITH INTACT (UNDAMAGED)
AND DAMAGED FUEL/FUEL DEBRIS

Bare Rod Array inside the DFC	Maximum k_{eff}		
	Assembly Classes 8x8F, 9x9E/F and 10x10G (4.0 wt%)	Assembly Class 10x10F (4.6 wt%)	All other assembly classes (4.8 wt%)
3x3	0.8985	n/c [†]	0.9267
6x6	0.9032	n/c	0.9295
8x8	0.9070	n/c	0.9344
9x9	0.9087	n/c	0.9371
10x10	0.9110	n/c	0.9387
11x11	0.9105	0.9341	0.9381
12x12	0.9099	n/c	0.9373
13x13	0.9084	n/c	0.9353
14x14	0.9075	n/c	0.9352
16x16	0.9064	n/c	0.9335
17x17	0.9042	n/c	0.9328

Note: The results do not include the bias for distributed enrichments discussed in Section 6.III.2.

[†] n/c = not calculated

Table 6.III.4.2

MAXIMUM k_{eff} VALUES IN THE MPC-68M FOR VARIOUS FUEL TYPES WITH VOIDED PELLET TO CLAD GAP

Assembly Classes	Enrichment	Maximum k_{eff} (Voided Gap)	Reference k_{eff} (Flooded Gap)	Delta k_{eff}
7X7B	4.8	0.9185	0.9243	-0.0058
8x8B	4.8	0.9210	0.9294	-0.0084
8x8C	4.8	0.9243	0.9302	-0.0059
8x8D	4.8	0.9245	0.9307	-0.0062
8x8E	4.8	0.9152	0.9211	-0.0059
8x8F	4.5	0.9191	0.9245	-0.0054
9x9A	4.8	0.9290	0.9341	-0.0051
9x9B	4.8	0.9202	0.9330	-0.0128
9x9C	4.8	0.9203	0.9254	-0.0051
9x9D	4.8	0.9210	0.9254	-0.0044
9x9E	4.5	0.9157	0.9254	-0.0097
9x9G	4.8	0.9160	0.9211	-0.0051
10x10A	4.8	0.9311	0.9339	-0.0028
10x10B	4.8	0.9242	0.9332	-0.0090
10x10C	4.8	0.9253	0.9300	-0.0047
10x10F	4.7	0.9301	0.9335	-0.0034
10x10G	4.6	0.9335	0.9372	-0.0037

Note: The results for the 10x10 fuel assembly classes do not include the bias for distributed enrichments discussed in Section 6.III.2.

Table 6.III.4.3

MAXIMUM k_{eff} VALUES IN THE MPC-68M FOR VARIOUS FUEL ROD NUMBERS, OTHER STUDIES

Assembly Class 8x8B (4.8% Enrichment), variable fuel rod number				
Assembly Class	Maximum k_{eff}	Description	Reference	
8x8B	0.9256	Variable Rod Numbers	0.9294	-0.0038
Assembly Class 8x8D (4.8% Enrichment), variable fuel rod number and water rod number				
8x8D	0.9271	Variable Rod Numbers - 2L/2S	0.9307	-0.0036
8x8D	0.9256	Variable Rod Numbers - 4L	0.9307	-0.0051
8x8D	0.9275	Variable Rod Numbers - 4S	0.9307	-0.0032
8x8D	0.9259	Variable Rod Numbers - GE-9	0.9307	-0.0048
8x8D	0.9277	Variable Rod Numbers - 3L	0.9307	-0.0030
Assembly Class 9x9E/F (4.5% enrichment) With Alternate (Closer) Location of the Water Rods				
9x9E/F	0.9231	Closer Water Rods	0.9271	-0.0040

HOLTEC INTERNATIONAL COPYRIGHTED MATERIAL

HI-STORM 100 FSAR
REPORT HI-2002444

6.III-23

Rev. 11

Table 6.III.4.4

MAXIMUM k_{eff} VALUES IN THE MPC-68M
FOR VARIOUS PART LENGTH ROD LENGTHS (10x10G, 4.6% Enrichment)

Maximum k_{eff}	Description
0.9117	Full Length Rods Only
0.9217	Part Length Rods 25% length
0.9312	Part Length Rods 50% length
0.9374	Part Length Rods 75% length
0.9372	All Rods

Note: The results do not include the bias for distributed enrichments discussed in Section 6.III.2.

Table 6.III.4.5

MAXIMUM k_{eff} VALUES IN THE MPC-68M
FOR METAMIC POISON GAP TOLERANCE CALCULATION
(10x10A, 4.8% Enrichment)

Description	Maximum k_{eff}
Reference	0.9339
Tolerance	0.9334

Note: The results do not include the bias for distributed enrichments discussed in Section 6.III.2.

HOLTEC INTERNATIONAL COPYRIGHTED MATERIAL

HI-STORM 100 FSAR
REPORT HI-2002444

6.III-25

Rev. 11

Table 6.III.4.6

MAXIMUM k_{eff} VALUES IN THE MPC-68M
FOR ECCENTRIC FUEL ASSEMBLY POSITION
(10x10A, 4.8% Enrichment)

Position	Maximum k_{eff}	Delta-k
In	0.9339	0.0074
Center	0.9265	reference
Out	0.9095	-0.0170

Note: The results do not include the bias for distributed enrichments discussed in Section 6.III.2.

Table 6.III.4.7

MAXIMUM k_{eff} VALUES IN THE MPC-68M
FOR EXTERNAL FLOODING

Internal Water Density (%)	External Water Density (%)	7x7B (4.8%)	8x8F (4.5%)	9x9C (4.8%)	10x10A (4.8%)	10x10G (4.6%)
100	100	0.9243	0.9245	0.9254	0.9351	0.9372
100	70	0.9238	0.9250	0.9259	0.9353	0.9388
100	50	0.9235	0.9239	0.9249	0.9336	0.9380
100	20	0.9234	0.9245	0.9259	0.9342	0.9383
100	10	0.9234	0.9245	0.9257	0.9351	0.9390
100	05	0.9238	0.9247	0.9258	0.9346	0.9387
100	01	0.9230	0.9256	0.9261	0.9341	0.9377

Note: The results do not include the bias for distributed enrichments discussed in Section 6.III.2.

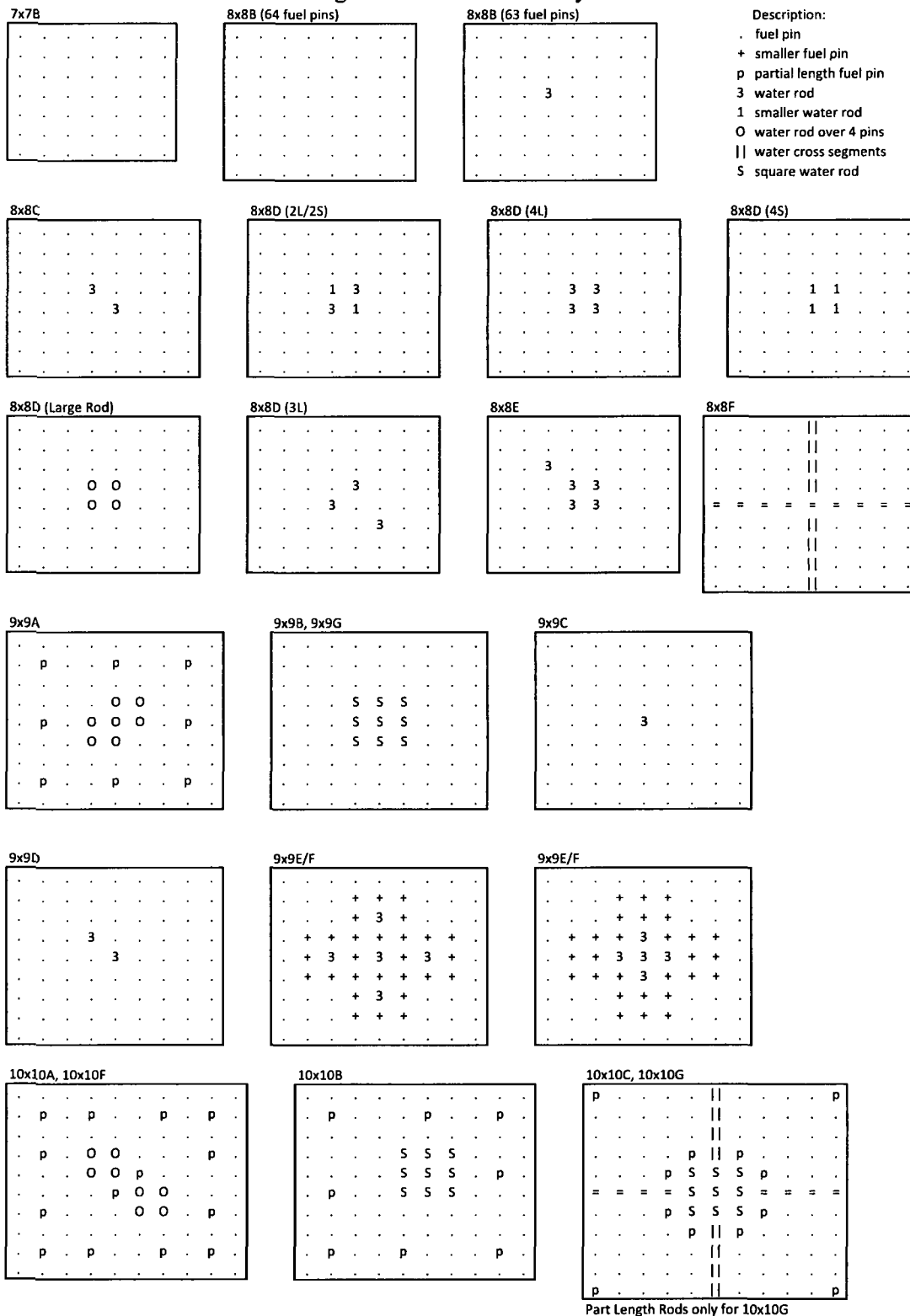
Table 6.III.4.8

MAXIMUM k_{eff} VALUES IN THE MPC-68M
FOR PARTIAL FLOODING

10x10A (4.8%)		
Flooded Condition (% Full)	Maximum k_{eff} , Horizontal Orientation	Maximum k_{eff} , Vertical Orientation
25	0.7897	0.9122
50	0.9044	0.9290
75	0.9297	0.9326
100	0.9337	0.9337

Note: The results do not include the bias for distributed enrichments discussed in Section 6.III.2.

Figure 6.III.4.1 Assembly Cross Sections



HOLTEC INTERNATIONAL COPYRIGHTED MATERIAL

6.III.5 CRITICALITY BENCHMARK EXPERIMENTS

Same as in Section 6.5

6.III.6 REGULATORY COMPLIANCE

Same as in Section 6.6

6.III.7 REFERENCES

- [6.III.1.1] NUREG-1536, Standard Review Plan for Dry Cask Storage Systems, USNRC, Washington, D.C., January 1997.
- [6.III.1.2] 10CFR72.124, "Criteria For Nuclear Criticality Safety."
- [6.III.1.3] USNRC Standard Review Plan, NUREG-0800, Section 9.1.2, Spent Fuel Storage, Rev. 2 - July 1981.
- [6.III.1.4] "HI-STAR 100 AND HI-STORM 100 ADDITIONAL CRITICALITY CALCULATIONS", Holtec Report HI-2012771 Rev.15 (proprietary)

HOLTEC INTERNATIONAL COPYRIGHTED MATERIAL

HI-STORM 100 FSAR
REPORT HI-2002444

6.III-30

Rev. 11

CHAPTER 7[†]: CONFINEMENT

7.0 INTRODUCTION

Confinement of all radioactive materials in the HI-STORM 100 System is provided by the MPC. The design of the HI-STORM 100 confinement boundary assures that there are no credible design basis events that would result in a radiological release to the environment. The HI-STORM 100 Overpack and HI-TRAC Transfer Cask are designed to provide physical protection for an MPC during normal, off-normal, and postulated accident conditions to assure that the integrity of the MPC confinement boundary is maintained. The inert atmosphere in the MPC and the passive heat removal capabilities of the HI-STORM 100 also assure that the SNF assemblies remain protected from degradation, which might otherwise lead to gross cladding ruptures during dry storage.

A detailed description of the confinement structures, systems, and components important to safety is provided in Chapter 2. The structural adequacy of the MPC is demonstrated by the analyses documented in Chapter 3. The physical protection of the MPC provided by the Overpack and the HI-TRAC Transfer Cask is demonstrated by the structural analyses documented in Chapter 3 and for off-normal and postulated accident conditions in Chapter 11. The heat removal capabilities of the HI-STORM 100 System are demonstrated by the thermal analyses documented in Chapter 4.

This chapter describes the HI-STORM 100 confinement boundary design and describes how the design satisfies the confinement requirements of 10CFR72 [7.0.1]. It also provides an evaluation of the MPC confinement boundary as it relates to the criteria contained in Interim Staff Guidance (ISG)-18 and ANSI N14.5-1997 [7.0.3] as justification for determining that leakage from the confinement boundary is not credible and, therefore, no confinement analysis is required.

This chapter is in compliance with NUREG-1536 except as noted in Table 1.0.3.

[†] This chapter has been prepared in the format and section organization set forth in Regulatory Guide 3.61. However, the material content of this chapter also fulfills the requirements of NUREG-1536. Pagination and numbering of sections, figures, and tables are consistent with the convention set down in *Chapter 1*, Section 1.0, herein. Finally, all terms-of-art used in this chapter are consistent with the terminology of the glossary (Table 1.0.1) and component nomenclature of the Bill-of-Materials (Section 1.5).

7.1 CONFINEMENT BOUNDARY

The primary confinement boundary against the release of radionuclides is the cladding of the individual fuel rods. The spent fuel rods are protected from degradation by maintaining an inert gas atmosphere (helium) inside the MPC and keeping the fuel cladding temperatures below the design basis values specified in Chapter 2.

The HI-STORM 100 confinement boundary consists of any one of the fully-welded MPC designs described in Chapter 1. Each MPC is identical from a confinement perspective so the following discussion applies to all MPCs. The confinement boundary of the MPC consists of:

- MPC shell
- bottom baseplate
- MPC lid (including the vent and drain port cover plates)
- MPC closure ring
- associated welds

The above items form a totally seal-welded vessel for the storage of design basis spent fuel assemblies.

The MPC requires no valves, gaskets or mechanical seals for confinement. Figure 7.1.1 shows an elevation cross-section of the MPC confinement boundary. All components of the confinement boundary are Important to Safety, Category A, as specified in Table 2.2.6. The MPC confinement boundary is designed and fabricated in accordance with the ASME Code, Section III, Subsection NB [7.1.1] to the maximum extent practicable. Chapter 2 provides design criteria for the confinement design. Section 2.2.4 provides applicable Code requirements. NRC-approved alternatives to specific Code requirements with complete justifications are presented in Table 2.2.15.

7.1.1 Confinement Vessel

The HI-STORM 100 System confinement vessel is the MPC. The MPC is designed to provide confinement of all radionuclides under normal, off-normal and accident conditions. The MPC is designed, fabricated, inspected, and tested in accordance with the applicable requirements of ASME, Section III, Subsection NB [7.1.1], including certain NRC-approved alternatives. The MPC shell and baseplate assembly and basket structure are delivered to the loading facility as one complete component. The MPC lid, vent and drain port cover plates, and closure ring are supplied separately and are installed following fuel loading. The MPC lid and closure ring are welded to the upper part of the MPC shell after fuel loading to provide redundant sealing of the confinement boundary. The vent and drain port cover plates are welded to the MPC lid after the lid is welded to the MPC. The welds forming the confinement boundary are described in detail in Section 7.1.3.

The MPC lid is made intentionally thick to minimize radiation exposure to workers during MPC closure operations, and is welded to the MPC shell. The vent and drain port cover plates are welded to the MPC lid following completion of MPC draining, moisture removal, and helium backfill activities to close the MPC vent and drain openings. The MPC lid has a stepped recess around the perimeter for accommodating the closure ring. The MPC closure ring is welded to the MPC lid on the inner diameter of the ring and to the MPC shell on the outer diameter. The combination of the welded MPC lid and closure ring form the redundant closure of the MPC.

Table 7.1.1 provides a summary of the design ratings for normal, off-normal and accident conditions for the MPC confinement vessel. Tables 1.2.2, 2.2.1, and 2.2.3 provide additional design basis information.

Helium leakage testing of the MPC base metals (shell, baseplate, and MPC lid) and MPC shell to baseplate and shell to shell welds is performed on the unloaded MPC.

Following fuel loading and MPC lid welding, the MPC lid-to-shell weld is examined by liquid penetrant method, volumetrically examined (or, if volumetric examination is not performed, multi-layer liquid penetrant examination must be performed), and pressure tested. If the MPC lid weld is acceptable, the vent and drain port cover plates are welded in place, examined by the liquid penetrant method and a leakage rate test is performed. Finally, the MPC closure ring is installed, welded and inspected by the liquid penetrant method. Chapters 8, 9, and 12 provide procedural guidance, acceptance criteria, and operating controls, respectively, for performance and acceptance of liquid penetrant examinations, volumetric examination, pressure testing and leakage rate testing of the field welds on the MPC.

After moisture removal, the MPC cavity is backfilled with helium. The helium backfill provides an inert atmosphere within the MPC cavity that precludes oxidation and hydride attack of the SNF cladding. Use of a helium atmosphere within the MPC contributes to the long-term integrity of the fuel cladding, reducing the potential for release of fission gas or other radioactive products to the MPC cavity. Helium also aids in heat transfer within the MPC and reduces the maximum fuel cladding temperatures. MPC inerting, in conjunction with the thermal design features of the MPC and storage cask, assures that the fuel assemblies are sufficiently protected against degradation, which might otherwise lead to gross cladding ruptures during long-term storage.

7.1.2 Confinement Penetrations

The MPC penetrations are designed to prevent the release of radionuclides under all normal, off-normal and accident conditions of storage. Two penetrations (the MPC vent and drain ports) are provided in the MPC lid for MPC draining, moisture removal and backfilling during MPC loading operations, and for fuel cool-down and MPC flooding during unloading operations. No other confinement penetrations exist in the MPC. The MPC vent and drain ports are equipped with metal-to-metal seals to minimize leakage and withstand the long-term effects of temperature and radiation. The vent and drain connectors allow the vent and drain ports to be operated like valves and prevent the need to hot tap into the penetrations during unloading operations. The MPC vent and drain ports are sealed by cover plates that are seal welded to the MPC lid. No credit is taken for the seal

provided by the vent and drain port caps. The MPC closure ring covers the vent and drain port cover plate welds and the MPC lid-to-shell weld, providing the redundant closure of the MPC vessel. The redundant closures of the MPC satisfy the requirements of 10CFR72.236(e) [7.0.1].

The MPC has no bolted closures or mechanical seals. The confinement boundary contains no external penetrations for pressure monitoring or overpressure protection.

7.1.3 Seals and Welds

The MPC is designed, fabricated, and tested in accordance with the applicable requirements of ASME, Section III, Subsection NB [7.1.1], with certain NRC-approved alternatives. The MPC has no bolted closures or mechanical seals. Section 7.1.1 describes the design of the confinement vessel welds. The welds forming the confinement boundary are summarized in Table 7.1.2.

Confinement boundary welds are performed, inspected, and tested in accordance with the applicable requirements of ASME Section III, Subsection NB [7.1.1] with certain NRC-approved alternatives. The use of multi-pass welds, root pass, for multiple pass welds, and final surface liquid penetrant inspection, and volumetric examination essentially eliminates the chance of a pinhole leak through the weld. If volumetric examination is not performed, multi-layer liquid penetrant examination must be performed. Helium leakage testing of the MPC base metals (shell, baseplate, and MPC lid) and MPC shell to baseplate and shell to shell welds is performed on the unloaded MPC. The vent and drain port cover plate welds are helium leak tested in the field, providing added assurance of weld integrity. Additionally, a Code pressure test is performed on the MPC lid-to-shell weld to confirm the weld's structural integrity after fuel loading. The ductile stainless steel material used for the MPC confinement boundary is not susceptible to delamination or hydrogen-induced weld degradation. The closure weld redundancy assures that failure of any single MPC confinement boundary closure weld does not result in release of radioactive material to the environment. Table 9.1.4 provides a summary of the closure weld examinations and tests.

7.1.4 Closure

The MPC is a totally seal-welded pressure vessel. The MPC has no bolted closure or mechanical seals. The MPC's redundant closures are designed to maintain confinement integrity during normal conditions of storage, and off-normal and postulated accident conditions. There are no unique or special closure devices. Primary closure welds (lid-to-shell and vent/drain port cover plate-to-lid) are examined using the liquid penetrant technique to ensure their integrity. Additionally, the vent and drain port cover plate-to-MPC lid welds are helium leakage tested to be leaktight in accordance with ANSI N14.5-1997 [7.0.3]. A description of the MPC weld examinations is provided in Chapter 9.

Since the MPC uses an entirely welded redundant closure system, no direct monitoring of the closure is required. Chapter 11 describes requirements for verifying the continued confinement capabilities of the MPC in the event of off-normal or accident conditions. As discussed in Section 2.3.3.2, no instrumentation is required or provided for HI-STORM 100 System storage operations, other than normal security service instruments and TLDs.

7.1.5 Damaged Fuel Container

The MPC is designed to allow for the storage of specified damaged fuel assemblies and fuel debris in a specially designed damaged fuel container (DFC). Fuel assemblies classified as damaged fuel or fuel debris as specified in Section 2.1.9 have been evaluated.

Damaged fuel assemblies and fuel debris will be loaded into stainless steel DFCs for storage in the HI-STORM 100 System. The DFCs that may be loaded into the MPCs are discussed in Section 2.1.3.

The DFC is designed to provide SNF loose component retention and handling capabilities. The DFC consists of a smooth-walled, welded stainless steel square container with a removable lid. The container lid provides the means of DFC closure and handling. The DFC is provided with stainless steel wire mesh screens in the top and bottom for draining, moisture removal and helium backfill operations. There are no other openings in the DFC. Section 2.1.9 specifies the fuel assembly characteristics for damaged fuel and fuel debris acceptable for loading in the MPC-24E, MPC-24EF, MPC-32, MPC-32F, MPC-68, MPC-68F or MPC-68FF.

Since the DFC has screens on the top and bottom, the DFC provides no pressure retention function. The confinement function of the DFC is limited to minimizing the release of loose particulates within the sealed MPC. The confinement function of the MPC is not altered by the presence of the DFCs. The radioactive material available for release from the specified fuel assemblies are bounded by the design basis fuel assemblies analyzed herein.

7.1.6 Design and Qualification of the MPC Lid-to-Shell Weld

The Holtec MPC lid-to-shell weld meets the criteria of NRC Interim Staff Guidance (ISG)-18 [7.1.2] such that leakage from the MPC lid-to-shell weld is not considered credible. Table 7.1.4 provides the matrix of ISG-18 criteria and how the Holtec MPC design and associated inspection, testing, and QA requirements meet each one. In addition, because proper execution of the MPC lid-to-shell weld is vital to ensuring no credible leakage from the field-welded MPC, Holtec shall review the closure welding procedures for conformance to Code and FSAR requirements.

Table 7.1.1

SUMMARY OF CONFINEMENT BOUNDARY DESIGN SPECIFICATIONS

Design Condition	Design Pressure (psig)	Design Temperature (°F)
Normal	100	MPC Lid: 550
		MPC Shell: 500
		MPC Baseplate: 400
Off-Normal	110	MPC Lid: 775
		MPC Shell: 775
		MPC Baseplate: 775
Accident	200	MPC Lid: 775
		MPC Shell: 775
		MPC Baseplate: 775

Table 7.1.2

MPC CONFINEMENT BOUNDARY WELDS

Confinement Boundary Welds		
MPC Weld Location	Weld Type†	ASME Code Category (Section III, Subsection NB)
Shell longitudinal seam	Full Penetration Groove (shop weld)	A
Shell circumferential seam	Full Penetration Groove (shop weld)	B
Baseplate to shell	Full Penetration Groove (shop weld)	C
MPC lid to shell	Partial Penetration Groove (field weld)	C
MPC closure ring to shell	Fillet (field weld)	††
Vent and drain port cover plates to MPC lid	Partial Penetration Groove (field weld)	D
MPC closure ring to closure ring radial	Partial Penetration Groove (field weld)	††
MPC closure ring to MPC lid	Partial Penetration Groove (field weld)	C

† The tests and inspections for the confinement boundary welds are listed in Section 9.1.1.

†† This joint is governed by NB-5271 (liquid penetrant examination).

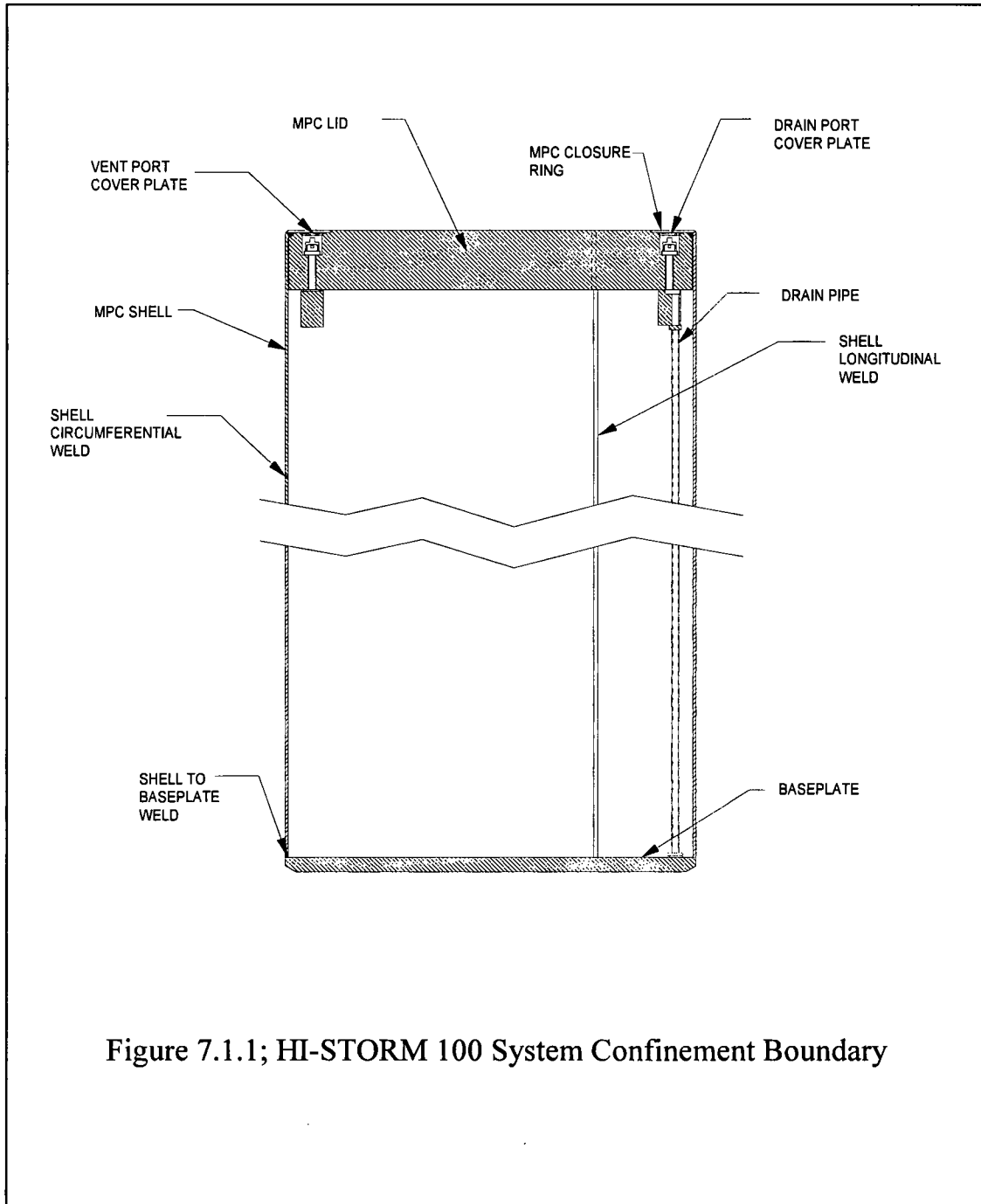
Table 7.1.3

TABLE DELETED

Table 7.1.4

COMPARISON OF HOLTEC MPC DESIGN WITH ISG-18 GUIDANCE FOR STORAGE

DESIGN/QUALIFICATION GUIDANCE	HOLTEC MPC DESIGN	FSAR REFERENCE
The canister is constructed from austenitic stainless steel	The MPC enclosure vessel is constructed entirely from austenitic stainless steel (Alloy X). Alloy X is defined as Type 304, 304LN, 316, or 316LN material	Section 1.2.1.1 and Appendix 1.A
The canister closure welds meet the guidance of ISG-15 (or approved alternative), Section X.5.2.3	The MPC lid-to-shell (LTS) closure weld meets ISG-15, Section X.5.2.3 for austenitic stainless steels. UT examination is permitted and NB-5332 acceptance criteria are required. An optional multi-layer PT examination is also permitted. The multi-layer PT is performed at each approximately 3/8" of weld depth, which corresponds to the critical flaw size. A weld quality factor of 0.45 (45% of actual weld capacity) has been used in the stress analysis.	Section 9.1.1.1 and Tables 2.2.15 and 9.1.4. HI-STAR FSAR Section 3.4.4.3.1.5 and Appendix 3.E (Docket 72-1008)
The canister maintains its confinement integrity during normal conditions, anticipated occurrences, and credible accidents, and natural phenomena	The MPC is shown by analysis to maintain confinement integrity for all normal, off-normal, and accident conditions, including natural phenomena. The MPC is design to withstand 45 g deceleration loadings and the cask system is analyzed to verify that decelerations due to credible drops and non-mechanistic tipovers will be less than 45 g's.	Section 3.4.4.3 and Appendix 3.A. HI-STAR FSAR Section 3.4.4.3
Records documenting the fabrication and closure welding of canisters shall comply with the provisions 10 CFR 72.174 and ISG-15. Record storage shall comply with ANSI N45.2.9.	Records documenting the fabrication and closure welding of MPCs meet the requirements of ISG-15 via controls required by the FSAR and HI-STORM CoC. Compliance with 10 CFR 72.174 and ANSI N.45.2.9 is achieved via Holtec QA program and implementing procedures.	Section 9.1.1.1 and Table 2.2.15 Section 13.0
Activities related to inspection, evaluation, documentation of fabrication, and closure welding of canisters shall be performed in accordance with an NRC-approved quality assurance program.	The NRC has approved the Holtec quality assurance program under 10 CFR 71. That QA program approval has been adopted for activities governed by 10 CFR 72 as permitted by 10 CFR 72.140(d)	Section 13.0



REQUIREMENTS FOR NORMAL AND OFF-NORMAL CONDITIONS OF STORAGE

The MPC uses multiple confinement barriers provided by the fuel cladding and the MPC enclosure vessel to assure that there is no release of radioactive material to the environment. Chapter 3 shows that all confinement boundary components are maintained within their Code-allowable stress limits during normal and off-normal storage conditions. Chapter 4 shows that the peak confinement boundary component temperatures and pressures are within the design basis limits for all normal and off-normal conditions of storage. Section 7.1 provides a discussion as to how the Holtec MPC design, welding, testing and inspection requirements meet the guidance of ISG-18 such that leakage from the confinement boundary may be considered non-credible. Since the MPC confinement vessel remains intact, and the design bases temperatures and pressure are not exceeded, leakage from the MPC confinement boundary is not credible during normal and off-normal conditions of storage.

CONFINEMENT REQUIREMENTS FOR HYPOTHETICAL ACCIDENT
CONDITIONS

The MPC uses redundant confinement closures to assure that there is no release of radioactive materials, including fission gases, volatiles, fuel fines or crud, for postulated storage accident conditions. The analyses presented in Chapters 3 and 11 demonstrate that the MPC remains intact during all postulated accident conditions, including the associated increased internal pressure due to decay heat generated by the stored fuel. The MPC is designed, fabricated, and tested in accordance with the applicable requirements of ASME, Section III, Subsection NB [7.1.1], with certain NRC-approved alternatives as listed in Table 2.2.15. Section 7.1 provides a discussion as to how the Holtec MPC design, welding, testing and inspection requirements meet the guidance of ISG-18 such that leakage from the confinement boundary may be considered non-credible. In summary, there is no mechanistic failure that results in a breach of and associated leakage of radioactive material from the MPC confinement boundary.

7.4 REFERENCES

- [7.0.1] 10CFR72, Licensing Requirements for the Independent Storage of Spent Nuclear Fuel and High-Level Radioactive Waste.
- [7.0.2] NUREG-1536, "Standard Review Plan for Dry Cask Storage Systems", January, 1997.
- [7.0.3] ANSI N14.5-1997, American National Standard for Radioactive Materials – Leakage Tests on Packages for Shipment”.
- [7.1.1] American Society of Mechanical Engineers (ASME), Boiler and Pressure Vessel Code, Section III, Division 1, Subsection NB, Class 1 Components, 1995 Edition.
- [7.1.2] Interim Staff Guidance 18, “The Design/Qualification of Final Closure Welds on Austenitic Stainless Steel Canisters as Confinement Boundary for Spent Fuel Storage and Containment Boundary for Spent Fuel Transportation,” May 2003.
- [7.2.1] Deleted
- [7.2.2] Deleted.
- [7.3.1] Deleted.
- [7.3.2] Deleted.
- [7.3.3] Deleted.
- [7.3.4] Deleted.
- [7.3.5] Deleted.
- [7.3.6] Deleted.
- [7.3.7] Deleted.
- [7.3.8] Deleted.
- [7.3.9] Deleted.
- [7.3.10] Deleted.

HOLTEC INTERNATIONAL COPYRIGHTED MATERIAL

HI-STORM FSAR
REPORT HI-2002444

Rev. 5

[7.3.11] Deleted.

HOLTEC INTERNATIONAL COPYRIGHTED MATERIAL

HI-STORM FSAR
REPORT HI-2002444

Rev. 5

7.4-2

HI-STORM 100 FSAR, NON-PROPRIETARY
REVISION 12
MARCH 12, 2014

SUPPLEMENT 7.I

CONFINEMENT EVALUATION OF THE HI-STORM 100U SYSTEM

7.I.1 INTRODUCTION

This supplement is solely focused on providing an evaluation of confinement safety of the HI-STORM 100U System. The evaluation presented herein supplements those evaluations of the HI-STORM 100 and HI-STORM 100S overpacks contained in the main body of Chapter 7 of this FSAR.

7.I.2 ACCEPTANCE CRITERIA

The acceptance criteria for confinement evaluations for the HI-STORM 100U system are identical to the criteria for the HI-STORM 100 System analyzed in the main body of Chapter 7.

7.I.3 EVALUATION

The HI-STORM 100U System differs from the HI-STORM 100 System only in the use of a different storage overpack, the HI-STORM 100U vertical ventilated module (VVM). All MPCs are identical between the two systems.

In summary, as the MPC design is unchanged by the addition of the HI-STORM 100U VVM, the material presented in Section 7.1.6 certifying that the MPC meets the criteria of ISG-18, is valid for the HI-STORM 100U System. Therefore, leakage from the MPC confinement boundary is not considered credible and no confinement analysis is required.

SUPPLEMENT 7.III

CONFINEMENT OF MPC-68M

7.III.0 The main body of this chapter remains fully applicable for the HI-STORM 100 System using an MPC-68M except as indicated below since the MPC-68M fuel basket is used with the MPC enclosure vessel which is the confinement boundary of the system.

7.III.1.5 Damaged Fuel Container

The MPC-68M is designed to allow for the storage of specified damaged fuel assemblies and fuel debris in a specially designed damaged fuel container (DFC). Section 2.III.1 specifies the fuel assembly characteristics for damaged fuel and fuel debris acceptable for loading in the MPC-68M.

CHAPTER 8: OPERATING PROCEDURES†

8.0 INTRODUCTION:

This chapter outlines the loading, unloading, and recovery procedures for the HI-STORM 100 System for storage operations. The procedures provided in this chapter are prescriptive to the extent that they provide the basis and general guidance for plant personnel in preparing detailed, written, site-specific, loading, handling, storage and unloading procedures. Users may add, modify the sequence of, perform in parallel, or delete steps as necessary provided that the intent of this guidance is met and the requirements of the CoC are met. The information provided in this chapter meets all requirements of NUREG-1536 [8.0.1].

Section 8.1 provides the guidance for loading the HI-STORM 100 System in the spent fuel pool. Section 8.2 provides the procedures for ISFSI operations and general guidance for performing maintenance and responding to abnormal events. Responses to abnormal events that may occur during normal loading operations are provided with the procedure steps. Section 8.3 provides the procedure for unloading the HI-STORM 100 System in the spent fuel pool. Section 8.4 provides the guidance for MPC transfer to the HI-STAR 100 Overpack for transport or storage. Section 8.4 can also be used for recovery of a breached MPC for transport or storage. Section 8.5 provides the guidance for transfer of the MPC into HI-STORM from the HI-STAR 100 transport overpack. Equipment specific operating details such as Vacuum Drying System, valve manipulation and Transporter operation are not within the scope of this FSAR and will be provided to users based on the specific equipment selected by the users and the configuration of the site.

The procedures contained herein describe acceptable methods for performing HI-STORM 100 loading and unloading operations. Unless otherwise stated, references to the HI-STORM 100 apply equally to the HI-STORM 100, 100S and 100S Version B. Users may alter these procedures to allow alternate methods and operations to be performed in parallel or out of sequence as long as the general intent of the procedure is met. In the figures following each section, acceptable configurations of rigging, piping, and instrumentation are shown. In some cases, the figures are artist's renditions. Users may select alternate configurations, equipment and methodology to accommodate their specific needs provided that the intent of this guidance is met and the requirements of the CoC are met. All rigging should be approved by the user's load handling authority prior to use. User-developed procedures and the design and operation of any alternate equipment must be reviewed by the Certificate holder prior to implementation.

Licensees (Users) will utilize the procedures provided in this chapter, equipment-specific operating instructions, and plant working procedures and apply them to develop the site specific written, loading and unloading procedures.

The loading and unloading procedures in Section 8.1 and 8.3 can also be appropriately revised

† This chapter has been prepared in the format and section organization set forth in Regulatory Guide 3.61. However, the material content of this chapter also fulfills the requirements of NUREG 1536. Pagination and numbering of sections, figures, and tables are consistent with the convention set down in Chapter 1, Section 1.0, herein. Finally, all terms-of-art used in this chapter are consistent with the terminology of the glossary (Table 1.0.1) and component nomenclature of the Bill-of-Materials (Section 1.5).

into written site-specific procedures to allow dry loading and unloading of the system in a hot cell or other remote handling facility. The Dry Transfer Facility (DTF) loading and unloading procedures are essentially the same with respect to loading removing moisture, and inerting, of the MPC. The dry transfer facility shall develop the appropriate site-specific procedures as part of the DTF facility license.

Tables 8.1.1 through 8.1.4 provide the handling weights for each of the HI-STORM 100 System major components and the loads to be lifted during various phases of the operation of the HI-STORM 100 System. Users shall take appropriate actions to ensure that the lift weights do not exceed user-supplied lifting equipment rated loads. Table 8.1.5 provides the HI-STORM 100 System bolt torque and sequencing requirements. Table 8.1.6 provides an operational description of the HI-STORM 100 System ancillary equipment along with its safety designation, where applicable. Fuel assembly selection and verification shall be performed by the licensee in accordance with written, approved procedures which ensure that only SNF assemblies authorized in the Certificate of Compliance and as defined in Section 2.1.9 are loaded into the HI-STORM 100 System.

In addition to the requirements set forth in the CoC, users will be required to develop or modify existing programs and procedures to account for the operation of an ISFSI. Written procedures will be required to be developed or modified to account for such things as nondestructive examination (NDE) of the MPC welds, handling and storage of items and components identified as Important to Safety, 10CFR72.48 [8.1.1] programs, specialized instrument calibration, special nuclear material accountability at the ISFSI, security modifications, fuel handling procedures, training and emergency response, equipment and process qualifications. Users are required to take necessary actions to prevent boiling of the water in the MPC. This may be accomplished by performing a site-specific analysis to identify a time limitation to ensure that water boiling will not occur in the MPC prior to the initiation of draining operations. Chapter 4 of the FSAR provides some sample time limits for the time to initiation of draining for various spent fuel pool water temperatures using design basis heat loads. Users are also required to take necessary actions to prevent the fuel cladding from exceeding temperature limits during drying operations and during handling of the MPC in the HI-TRAC transfer cask. Section 4.5 of the FSAR provides requirements on the necessary actions, if any, based on the heat load of the MPC.

Table 8.1.7 summarizes some of the instrumentation used to load and unload the HI-STORM 100 System. Tables 8.1.8, 8.1.9, and 8.1.10 provide sample receipt inspection checklists for the HI-STORM 100 overpack, the MPC, and the HI-TRAC Transfer Cask, respectively. Users may develop site-specific receipt inspection checklists, as required for their equipment. Fuel handling shall be performed in accordance with written site-specific procedures.

Technical and Safety Basis for Loading and Unloading Procedures

The procedures herein are developed for the loading, storage, unloading, and recovery of spent fuel in the HI-STORM 100 System. The activities involved in loading of spent fuel in a canister system, if not carefully performed, may present risks. The design of the HI-STORM 100 System, including these procedures, the ancillary equipment and the Technical Specifications, serve to minimize risks and mitigate consequences of potential events. To summarize, consideration is given in the loading and unloading systems and procedures to the potential events listed in Table 8.0.1.

The primary objective is to reduce the risk of occurrence and/or to mitigate the consequences of the event. The procedures contain Notes, Warnings, and Cautions to notify the operators to upcoming situations and provide additional information as needed. The Notes, Warnings and Cautions are purposely bolded and boxed and immediately precede the applicable steps.

In the event of an extreme abnormal condition (e.g., cask drop or tip-over event) the user shall have appropriate procedural guidance to respond to the situation. As a minimum, the procedures shall address establishing emergency action levels, implementation of emergency action program, establishment of personnel exclusions zones, monitoring of radiological conditions, actions to mitigate or prevent the release of radioactive materials, and recovery planning and execution and reporting to the appropriate regulatory agencies, as required.

HOLTEC INTERNATIONAL COPYRIGHTED MATERIAL

HI-STORM FSAR
REPORT HI-2002444

8.0-3

Rev. 10

HI-STORM 100 FSAR, NON-PROPRIETARY
REVISION 12
MARCH 12, 2014

Table 8.0.1
OPERATIONAL CONSIDERATIONS

POTENTIAL EVENTS	METHODS USED TO ADDRESS EVENT	COMMENTS/ REFERENCES
Cask Drop During Handling Operations	Cask lifting and handling equipment is designed to ANSI N14.6. Procedural guidance is given for cask handling, inspection of lifting equipment, and proper engagement to the trunnions.	See Section 8.1.2.
Cask Tip-Over Prior to welding of the MPC lid	The Lid Retention System is available to secure the MPC lid during movement between the spent fuel pool and the cask preparation area.	See Section 8.1.5. See Figure 8.1.15.
Contamination of the MPC external shell	The annulus seal, pool lid, and Annulus Overpressure System minimize the potential for the MPC external shell to become contaminated from contact with the spent fuel pool water.	See Figures 8.1.13 and 8.1.14.
Contamination spread from cask process system exhausts	Processing systems are equipped with exhausts that can be directed to the plant's processing systems.	See Figures 8.1.19-8.1.22.
Damage to fuel assembly cladding from oxidation	Fuel assemblies are never subjected to air or oxygen during loading and unloading operations.	See Section 8.1.5, and Section 8.3.3
Damage to Vacuum Drying System vacuum gauges from positive pressure	Vacuum Drying System is separate from pressurized gas and water systems.	See Figure 8.1.22 and 8.1.23.
Ignition of combustible mixtures of gas (e.g., hydrogen) during MPC lid welding or cutting	The area around MPC lid shall be appropriately monitored for combustible gases prior to, and during welding or cutting activities. The space below the MPC lid shall be purged prior to, and during these activities.	See Section 8.1.5 and Section 8.3.3.

HOLTEC INTERNATIONAL COPYRIGHTED MATERIAL

Table 8.0.1
OPERATIONAL CONSIDERATIONS
(CONTINUED)

POTENTIAL EVENTS	METHODS USED TO ADDRESS EVENT	COMMENTS/ REFERENCES
Excess dose from failed fuel assemblies	MPC gas sampling allows operators to determine the integrity of the fuel cladding prior to opening the MPC. This allows preparation and planning for failed fuel. The RVOAs allow the vent and drain ports to be operated like valves and prevent the need to hot tap into the penetrations during unloading operation.	See Figure 8.1.16 and Section 8.3.3.
Excess dose to operators	The procedures provide ALARA Notes and Warnings when radiological conditions may change.	See ALARA Notes and Warnings throughout the procedures.
Excess generation of radioactive waste	The HI-STORM system uses process systems that minimize the amount of radioactive waste generated. Such features include smooth surfaces for ease of decontamination efforts, prevention of avoidable contamination, and procedural guidance to reduce decontamination requirements. Where possible, items are installed by hand and require no tools.	Examples: HI-TRAC bottom protective cover, bolt plugs in empty holes, pre-wetting of components.
Fuel assembly misloading event	Procedural guidance is given to perform assembly selection verification and a post-loading visual verification of assembly identification prior to installation of the MPC lid.	See Section 8.1.4.
Incomplete moisture removal from MPC	The vacuum drying process reduces the MPC pressure in stages to prevent the formation of ice. Vacuum is held below 3 torr for 30 minutes with the vacuum pump isolated to assure dryness. If the forced helium dehydration process used, the temperature of the gas exiting the demister is held below 21 °F for a minimum of 30 minutes. The TS require the surveillance requirement for moisture removal to be met before entering transport operations	See Section 8.1.5

Table 8.0.1
OPERATIONAL CONSIDERATIONS
(CONTINUED)

POTENTIAL EVENTS	METHODS USED TO ADDRESS EVENT	COMMENTS/ REFERENCES
Incorrect MPC lid installation	Procedural guidance is given to visually verify correct MPC lid installation prior to HI-TRAC removal from the spent fuel pool.	See Section 8.1.5.
Load Drop	Rigging diagrams and procedural guidance are provided for all lifts. Component weights are provided in Tables 8.1.1 through 8.1.4.	See Figures 8.1.6, 8.1.7, 8.1.9, 8.1.25 and 8.1.27. See Tables 8.1.1 through 8.1.4.
Over-pressurization of MPC during loading and unloading	Pressure relief valves in the water and gas processing systems limit the MPC pressure to acceptable levels.	See Figures 8.1.20, 8.1.21, 8.1.23 and 8.3.3.
Overstressing MPC lift lugs from side loading	The MPC is upended using the upending frame.	See Figure 8.1.6 and Section 8.1.2.
Overweight cask lift	Procedural guidance is given to alert operators to potential overweight lifts.	See Section 8.1.7 for example. See Tables 8.1.1 through 8.1.4.
Personnel contamination by cutting/grinding activities	Procedural guidance is given to warn operators prior to cutting or grinding activities.	See Section 8.1.5 and Section 8.3.3.
Transfer cask carrying hot particles out of the spent fuel pool	Procedural guidance is given to scan the transfer cask prior to removal from the spent fuel pool.	See Section 8.1.3 and Section 8.1.5.
Unplanned or uncontrolled release of radioactive materials	The MPC vent and drain ports are equipped with metal-to-metal seals to minimize the leakage during moisture removal and helium backfill operations. Unlike elastomer seals, the metal seals resist degradation due to temperature and radiation and allow future access to the MPC ports without hot tapping. The RVOAs allow the port to be opened and closed like a valve so gas sampling may be performed.	See Figure 8.1.11 and 8.1.16. See Section 8.3.3.

HOLTEC INTERNATIONAL COPYRIGHTED MATERIAL

HI-STORM FSAR
REPORT HI-2002444

8.0-6

Rev. 10

HI-STORM 100 FSAR, NON-PROPRIETARY
REVISION 12
MARCH 12, 2014

8.1 PROCEDURE FOR LOADING THE HI-STORM 100 SYSTEM IN THE SPENT FUEL POOL

8.1.1 Overview of Loading Operations:

The HI-STORM 100 System is used to load, transfer and store spent fuel. Specific steps are performed to prepare the HI-STORM 100 System for fuel loading, to load the fuel, to prepare the system for storage and to place it in storage at an ISFSI. The MPC transfer may be performed in the cask receiving area, at the ISFSI, or any other location deemed appropriate by the user. HI-TRAC and/or HI-STORM may be transferred between the ISFSI and the fuel loading facility using a specially designed transporter, heavy haul transfer trailer, or any other load handling equipment designed for such applications as long as the lift height restrictions are met (lift height restrictions apply only to suspended forms of transport). Users shall develop detailed written procedures to control on-site transport operations. Section 8.1.2 provides the general procedures for rigging and handling of the HI-STORM overpack and HI-TRAC transfer cask. Figure 8.1.1 shows a general flow diagram of the HI-STORM loading operations. The operations described below are envisioned to occur in a continuous fashion within a reasonable time frame.

Refer to the boxes of Figure 8.1.2 for the following description. At the start of loading operations, an empty MPC is upended (Box 1). The empty MPC is raised and inserted into HI-TRAC (Box 2). The annulus is filled with plant demineralized water[†] and the MPC is filled with either spent fuel pool water or plant demineralized water (borated as required) (Box 3). An inflatable seal is installed in the upper end of the annulus between the MPC and HI-TRAC to prevent spent fuel pool water from contaminating the exterior surface of the MPC. HI-TRAC and the MPC are then raised and lowered into the spent fuel pool for fuel loading using the lift yoke (Box 4). Pre-selected assemblies are loaded into the MPC and a visual verification of the assembly identification is performed (Box 5).

While still underwater, a thick shielded lid (the MPC lid) is installed using either slings attached to the lift yoke or the optional Lid Retention System (Box 6). The lift yoke remotely engages to the HI-TRAC lifting trunnions to lift the HI-TRAC and loaded MPC close to the spent fuel pool surface (Box 7). When radiation dose rate measurements confirm that it is safe to remove the HI-TRAC from the spent fuel pool, the cask is removed from the spent fuel pool. If the Lid Retention System is being used, the HI-TRAC top lid bolts are installed to secure the MPC lid for the transfer to the cask preparation area. The lift yoke and HI-TRAC are sprayed with demineralized water to help remove contamination as they are removed from the spent fuel pool.

HI-TRAC is placed in the designated preparation area and the Lift Yoke and Lid Retention System (if utilized) are removed. The next phase of decontamination is then performed. The top surfaces of the MPC lid and the upper flange of HI-TRAC are decontaminated. The Temporary Shield Ring (if utilized) is installed and filled with water and the neutron shield jacket is filled with water[‡] (if drained). The inflatable annulus seal is removed, and the annulus shield (if

[†] Users may substitute domestic water in each step where demineralized water is specified.

[‡] Filled water jacket is relied in Section 4.5 thermal analysis of HI-TRAC in the dry and helium filled MPC condition.

utilized) is installed. The Temporary Shield Ring provides additional personnel shielding around the top of the HI-TRAC during MPC closure operations. The annulus shield provides additional personnel shielding at the top of the annulus and also prevents small items from being dropped into the annulus. Dose rates are measured at the MPC lid to ensure that the dose rates are within expected values.

The MPC water level is lowered slightly, the MPC is vented, and the MPC lid is seal welded using the automated welding system (Box 8). Visual examinations are performed on the tack welds. Liquid penetrant (PT) examinations are performed on the root and final passes. An ultrasonic or multi-layer PT examination is performed on the MPC Lid-to-Shell weld to ensure that the weld is satisfactory. As an alternative to volumetric examination of the MPC lid-to-shell weld, a multi-layer PT is performed including one intermediate examination after approximately every three-eighth inch of weld depth. The MPC Lid-to-Shell weld is then pressure tested followed by an additional liquid penetrant examination performed on the MPC Lid-to-Shell weld to verify structural integrity. To calculate the helium backfill requirements for the MPC (if the backfill is based upon helium mass or volume measurements), the free volume inside the MPC must first be determined. This free volume may be determined by measuring the volume of water displaced or any other suitable means.

Depending upon the burn-up or decay heat load of the fuel to be loaded in the MPC, moisture is removed from the MPC using either a vacuum drying system or forced helium dehydration system. For MPCs without high burn-up fuel and with sufficiently low decay heat, the vacuum drying system may be connected to the MPC and used to remove all liquid water from the MPC in a stepped evacuation process (Box 9). A stepped evacuation process is used to preclude the formation of ice in the MPC and vacuum drying system lines. The internal pressure is reduced to below 3 torr and held for 30 minutes to ensure that all liquid water is removed.

For high-burn-up fuel or MPCs with high decay heat, or as an alternative for MPCs without high burn-up fuel and with lower decay heat, a forced helium dehydration system is utilized to remove residual moisture from the MPC. Gas is circulated through the MPC to evaporate and remove moisture. The residual moisture is condensed until no additional moisture remains in the MPC. The temperature of the gas exiting the system demister is maintained below 21°F for a minimum of 30 minutes to ensure that all liquid water is removed.

Following MPC moisture removal, the MPC is backfilled with a predetermined amount of helium gas. If the MPC contains high burn-up fuel and MPC heat load greater than the threshold heat load setting in Table 4.5.4, then a Supplemental Cooling System (SCS) is connected to the HI-TRAC annulus prior to helium backfill and is used to circulate coolant to maintain fuel cladding temperatures below ISG-11 Rev. 3 limits (See Figure 2.C.1). The helium backfill ensures adequate heat transfer during storage, and provides an inert atmosphere for long-term fuel integrity. Cover plates are installed and seal welded over the MPC vent and drain ports with liquid penetrant examinations performed on the root and final passes (for multi-pass welds) (Box 10). The cover plate welds are then leak tested.

The MPC closure ring is then placed on the MPC and dose rates are measured at the MPC lid to ensure that the dose rates are within expected values. The closure ring is aligned, tacked in place and seal welded providing redundant closure of the MPC confinement boundary closure welds.

HOLTEC INTERNATIONAL COPYRIGHTED MATERIAL

Tack welds are visually examined, and the root and final welds are inspected using the liquid penetrant examination technique to ensure weld integrity.

The annulus shield (if utilized) is removed and the remaining water in the annulus is drained. The Temporary Shield Ring (if utilized) is drained and removed. The MPC lid and accessible areas of the top of the MPC shell are smeared for removable contamination. HI-TRAC top lid³ is installed and the bolts are torqued (Box 11). HI-TRAC surface dose rates are measured in accordance with the technical specifications. The MPC lift cleats are installed on the MPC lid. The MPC lift cleats are the primary lifting point on the MPC. MPC slings are installed between the MPC lift cleats and the lift yoke (Box 12).

If the HI-TRAC 125 is being used, the transfer lid is attached to the HI-TRAC as follows. The HI-TRAC is positioned above the transfer slide to prepare for bottom lid replacement. The transfer slide consists of an adjustable-height rolling carriage and a pair of channel tracks. The transfer slide supports the transfer step which is used to position the two lids at the same elevation and creates a tight seam between the two lids to eliminate radiation streaming. The overhead crane is shut down to prevent inadvertent operation. The transfer slide carriage is raised to support the pool lid while the bottom lid bolts are removed. The transfer slide then lowers the pool lid and replaces the pool lid with the transfer lid. The carriage is raised and the bottom lid bolts are replaced. The MPC lift cleats and slings support the MPC during the transfer operations. Following the transfer, the MPC slings are disconnected and HI-TRAC is positioned for MPC transfer into HI-STORM.

MPC transfer may be performed inside or outside the fuel building (Box 13). Similarly, HI-TRAC and HI-STORM may be transferred to the ISFSI in several different ways (Box 14 and 15). The empty HI-STORM overpack is inspected and positioned with the lid removed. Vent duct shield inserts² are installed in the HI-STORM exit vent ducts. The vent duct shield inserts prevent radiation streaming from the HI-STORM Overpack as the MPC is lowered past the exit vents. If the HI-TRAC 100D or 125D is used, the mating device is positioned on top of the HI-STORM. The HI-TRAC is placed on top of HI-STORM. An alignment device (or mating device in the case of HI-TRAC 100D and 125D) helps guide HI-TRAC during this operation³. The MPC may be lowered using the MPC downloader, the main crane hook or other similar devices. The MPC downloader (if used) may be attached to the HI-TRAC lid or mounted to the overhead lifting device. The MPC slings are attached to the MPC lift cleats.

If used, the Supplemental Cooling System (SCS) will be disconnected from the HI-TRAC and the HI-TRAC annulus drained, prior to transfer of the MPC from the HI-TRAC to the HI-STORM. If the transfer doors are used (i.e. not the HI-TRAC 100D or 125D), the MPC is raised slightly, the transfer lid door locking pins are removed and the doors are opened. If the HI-TRAC 100D or 125D is used, the pool lid is removed and the mating device drawer is opened.

² Vent duct shield inserts are only used on the HI-STORM 100.

³ The alignment guide may be configured in many different ways to accommodate the specific sites. See Table 8.1.6.

³ Users with the optional HI-TRAC Lid Spacer shall modify steps in their procedures to install and remove the spacer together with top lid

Optional trim plates may be installed on the top and bottom of both doors (or drawer for HI-TRAC 100D and 125D) and secured using hand clamps. The trim plates eliminate radiation streaming above and below the doors (drawer). The MPC is lowered into HI-STORM. Following verification that the MPC is fully lowered, the MPC slings are disconnected from the lifting device and lowered onto the MPC lid. The trim plates are removed, the doors (or drawer) are closed. The empty HI-TRAC must be removed with the doors open when the HI-STORM 100S is used to prevent interference with the lift cleats and slings. HI-TRAC is removed from on top of HI-STORM. The MPC slings and MPC lift cleats are removed. Hole plugs are installed in the empty MPC lifting holes to fill the voids left by the lift cleat bolts. The alignment device (or mating device with pool lid for HI-TRAC 100D and 125D) and vent duct shield inserts (if used) are removed, and the HI-STORM lid is installed. The exit vent gamma shield cross plates, temperature elements (if used) and vent screens are installed. The HI-STORM lid studs and nuts or lid closure bolts are installed. HI-STORM surface dose rates are measured in accordance with the technical specifications. The HI-STORM is secured to the transporter (as applicable) and moved to the ISFSI pad. The HI-STORM Overpack and HI-TRAC transfer cask may be moved using a number of methods as long as the lifting equipment requirements are met. For sites with high seismic conditions, the HI-STORM 100A is anchored to the ISFSI. Once located at the storage pad, the inlet vent gamma shield cross plates are installed. Finally, the temperature elements and their instrument connections are installed (if used), and the air temperature rise testing (if required) is performed to ensure that the system is functioning within its design parameters.

8.1.2 HI-TRAC and HI-STORM Receiving and Handling Operations

Note:

HI-TRAC may be received and handled in several different configurations and may be transported on-site in a horizontal or vertical orientation. This section provides general guidance for HI-TRAC and HI-STORM handling. Site-specific procedures shall specify the required operational sequences based on the handling configuration at the sites.

1. Vertical Handling of HI-TRAC:

- a. Verify that the lift yoke initial acceptance testing and any periodic re-certifications are current, in accordance with ANSI N14.6.
- b. Visually inspect the lifting device (lift yoke or lift links) and the lifting trunnions for gouges, cracks, deformation or other indications of damage. Replace or repair damaged components as necessary.
- c. Engage the lift yoke to the lifting trunnions. See Figure 8.1.3.
- d. Apply lifting tension to the lift yoke and verify proper engagement of the lift yoke.

Note:

Refer to the site's heavy load handling procedures for lift height, load path, floor loading and other applicable load handling requirements.

Warning:

When lifting the loaded HI-TRAC with only the pool lid, the HI-TRAC should be carried as low as practicable. This minimizes the dose rates due to radiation scattering from the floor. Personnel should remain clear of the area and the HI-TRAC should be placed in position as soon as practicable.

- e. Raise HI-TRAC and position it accordingly.
2. Upending of HI-TRAC in the Transfer Frame:
 - a. Position HI-TRAC under the lifting device. Refer to Step 1, above.
 - b. If necessary, remove the missile shield from the HI-TRAC Transfer Frame. See Figure 8.1.4.
 - c. Verify that the lift yoke initial acceptance testing and any periodic recertifications are current, in accordance with ANSI N14.6.
 - d. Visually inspect the lift yoke and the lifting trunnions for gouges, cracks, deformation or other indications of damage. Repair or replace damaged components as necessary.
 - e. Deleted.
 - f. Engage the lift yoke to the lifting trunnions. (The use of a ratchet strap or similar device to restrain the lift yoke arms is recommended during HI-TRAC Upending Operations.) See Figure 8.1.3.
 - g. Apply lifting tension to the lift yoke and verify proper engagement of the lift yoke.
 - h. Slowly rotate HI-TRAC to the vertical position keeping all rigging as close to vertical as practicable. See Figure 8.1.4.
 - i. If used, lift the pocket trunnions clear of the Transfer Frame rotation trunnions.
3. Downending of HI-TRAC in the Transfer Frame:

ALARA Warning:

Due to the higher dose rates under the pool and transfer lid, use of auxiliary shielding should be considered when downending a loaded HI-TRAC.

- a. Position the Transfer Frame under the lifting device.
- b. Verify that the lift yoke initial acceptance testing and any periodic recertifications are current, in accordance with ANSI N14.6.
- c. Visually inspect the lift yoke and the lifting trunnions for gouges, cracks, deformation or other indications of damage. Repair or replace damaged components as necessary.
- d. Deleted.
- e. Deleted.

- f. Engage the lift yoke to the lifting trunnions. (The use of a ratchet strap or similar device to restrain the lift yoke arms is recommended during HI-TRAC Downending Operations.) See Figure 8.1.3.
- g. Apply lifting tension to the lift yoke and verify proper lift yoke engagement.
- h. Position the pocket trunnions to receive the Transfer Frame rotation trunnions. See Figure 8.1.4 (Not used for HI-TRAC 100D and 125D).
- i. Slowly rotate HI-TRAC to the horizontal position keeping all rigging as close to vertical as practicable.
- j. Disengage the lift yoke.

4. Horizontal Handling of HI-TRAC in the Transfer Frame:

ALARA Warning:

Due to the higher dose rates under the pool and transfer lid, use of auxiliary shielding should be considered when handling a loaded HI-TRAC in horizontal orientation.

- a. Verify that the Transfer Frame is secured to the transport vehicle as necessary.
- b. Downend HI-TRAC on the Transfer Frame per Step 3, if necessary.
- c. If necessary, install the HI-TRAC missile Shield on the HI-STAR 100 Transfer Frame (See Figure 8.1.4).

5. Vertical Handling of HI-STORM:

Note:

The HI-STORM 100 Overpack may be lifted with a special lifting device that engages the overpack anchor blocks with threaded studs and connects to a cask transporter, crane, or similar equipment. The device is designed in accordance with ANSI N14.6.

- a. Visually inspect the HI-STORM lifting device for gouges, cracks, deformation or other indications of damage.
- b. Visually inspect the transporter lifting attachments for gouges, cracks, deformation or other indications of damage.
- c. If necessary, attach the transporter's lifting device to the transporter and HI-STORM.
- d. Raise and position HI-STORM accordingly. See Figure 8.1.5.

6. Empty MPC Installation in HI-TRAC:

Note:

To avoid side loading the MPC lift lugs, the MPC must be upended in the MPC Upending Frame (or equivalent). See Figure 8.1.6.

- a. If necessary, rinse off any road dirt with water. Remove any foreign objects from the MPC internals.

- b. If necessary, upend the MPC as follows:
1. Visually inspect the MPC Upending Frame for gouges, cracks, deformation or other indications of damage. Repair or replace damaged components as necessary.
 2. Install the MPC on the Upending Frame. Make sure that the banding straps are secure around the MPC shell. See Figure 8.1.6.
 3. Inspect the Upending Frame slings in accordance with the site's lifting equipment inspection procedures. Rig the slings around the bar in a choker configuration to the outside of the cleats. See Figure 8.1.6.
 4. Attach the MPC upper end slings of the Upending Frame to the main overhead lifting device. Attach the bottom-end slings to a secondary lifting device (or a chain fall attached to the primary lifting device) (See Figure 8.1.6).
 5. Raise the MPC in the Upending Frame.

Warning:

The Upending Frame corner should be kept close to the ground during the upending process.

6. Slowly lift the upper end of the Upending Frame while lowering the bottom end of the Upending Frame.
 7. When the MPC approaches the vertical orientation, tension on the lower slings may be released.
 8. Place the MPC in a vertical orientation.
 9. Disconnect the MPC straps and disconnect the rigging.
- c. Install the MPC in HI-TRAC as follows:
1. Install the four point lift sling to the lift lugs inside the MPC. See Figure 8.1.7.
 2. Raise and place the MPC inside HI-TRAC.

Note:

An alignment punch mark is provided on HI-TRAC and the top edge of the MPC. Similar marks are provided on the MPC lid and closure ring. See Figure 8.1.8.

3. Rotate the MPC so the alignment marks agree and seat the MPC inside HI-TRAC. Disconnect the MPC rigging or the MPC lift rig.

8.1.3 HI-TRAC and MPC Receipt Inspection and Loading Preparation

Note:

Receipt inspection, installation of the empty MPC in the HI-TRAC, and lower fuel spacer installation may occur at any location or be performed at any time prior to complete submersion in the spent fuel pool as long as appropriate steps are taken to prevent contaminating the exterior of the MPC or interior of the HI-TRAC.

ALARA Note:

A bottom protective cover may be attached to HI-TRAC pool lid bottom. This will help prevent imbedding contaminated particles in HI-TRAC bottom surface and ease the decontamination effort.

1. Place HI-TRAC in the cask receiving area. Perform appropriate contamination and security surveillances, as required.
2. If necessary, remove HI-TRAC Top Lid by removing the top lid bolts and using the lift sling. See Figure 8.1.9 for rigging.
 - a. Rinse off any road dirt with water. Inspect all cavity locations for foreign objects. Remove any foreign objects.
 - b. Perform a radiological survey of the inside of HI-TRAC to verify there is no residual contamination from previous uses of the cask.
3. Disconnect the rigging.
4. Store the Top Lid and bolts in a site-approved location.
5. If necessary, configure HI-TRAC with the pool lid as follows:

ALARA Warning:

The bottom lid replacement as described below may be performed only on an empty HI-TRAC.

- a. Inspect the seal on the pool lid for cuts, cracks, gaps and general condition. Replace the seal if necessary.
- b. Remove the bottom lid bolts and store them temporarily.
- c. Raise the empty HI-TRAC and position it on top of the pool lid.
- d. Inspect the pool lid bolts for general condition. Replace worn or damaged bolts with new bolts.
- e. Install the pool lid bolts. See Table 8.1.5 for torque requirements.
- f. If necessary, thread the drain connector pipe to the pool lid.
- g. Store the HI-TRAC Transfer Lid in a site-approved location.

HOLTEC INTERNATIONAL COPYRIGHTED MATERIAL

6. At the site's discretion, perform an MPC receipt inspection and cleanliness inspection in accordance with a site-specific inspection checklist.
7. Install the MPC inside HI-TRAC and place HI-TRAC in the designated preparation area. See Section 8.1.2.

Note:

Upper fuel spacers are fuel-type specific. Not all fuel types require fuel spacers. Upper fuel spacer installation may occur any time prior to MPC lid installation.

8. Install the upper fuel spacers in the MPC lid as follows:

Warning:

Never work under a suspended load.

- a. Position the MPC lid on supports to allow access to the underside of the MPC lid.
- b. Thread the fuel spacers into the holes provided on the underside of the MPC lid. See Figure 8.1.10 and Table 8.1.5 for torque requirements.
- c. Install threaded plugs in the MPC lid where and when spacers will not be installed, if necessary. See Table 8.1.5 for torque requirements.

9. At the user's discretion perform an MPC lid and closure ring fit test:

Note:

It may be necessary to perform the MPC installation and inspection in a location that has sufficient crane clearance to perform the operation.

- a. Visually inspect the MPC lid rigging (See Figure 8.1.9).
- b. At the user's discretion, raise the MPC lid such that the drain line can be installed. Install the drain line to the underside of the MPC lid. See Figure 8.1.11.

Note:

The MPC Shell is relatively flexible compared to the MPC Lid and may create areas of local contact that impede Lid insertion in the Shell. Grinding of the MPC Lid below the minimum diameter on the drawing is permitted to alleviate interference with the MPC Shell in areas of localized contact. If the amount of material removed from the surface exceeds 1/8", the surface shall be examined by a liquid penetrant method (NB-2546). The weld prep for the Lid-to-Shell weld shall be maintained after grinding.

- c. Align the MPC lid and lift yoke so the drain line will be positioned in the MPC drain location. See Figure 8.1.12. Install the MPC lid. Verify that the MPC lid fit and weld prep are in accordance with the design drawings.

ALARA Note:

The closure ring is installed by hand. Some grinding may be required on the closure ring to adjust the fit.

- d. Install, align and fit-up the closure ring.

HOLTEC INTERNATIONAL COPYRIGHTED MATERIAL

- e. Verify that closure ring fit and weld prep are in accordance with the fabrication drawings or the approved design drawings.
 - f. Remove the closure ring, vent and drain port cover plates and the MPC lid. Disconnect the drain line. Store these components in an approved plant storage location.
10. At the user's discretion, perform an MPC vent and drain port cover plate fit test and verify that the weld prep is in accordance with the approved fabrication drawings.

Note:

Fuel spacers are fuel-type specific. Not all fuel types require fuel spacers. Lower fuel spacers are set in the MPC cells manually. No restraining devices are used.

11. Install lower fuel spacers in the MPC (if necessary). See Figure 8.1.10.
12. Fill the MPC and annulus as follows:
- a. Fill the annulus with plant demineralized water to just below the inflatable seal seating surface.

Caution:

Do not use any sharp tools or instruments to install the inflatable seal. Some air in the inflatable seal helps in the installation.

- b. Manually insert the inflatable annulus seal around the MPC. See Figure 8.1.13.
- c. Ensure that the seal is uniformly positioned in the annulus area.
- d. Inflate the seal.
- e. Visually inspect the seal to ensure that it is properly seated in the annulus. Deflate, adjust and inflate the seal as necessary. Replace the seal as necessary.

ALARA Note:

Bolt plugs installed, and/or waterproof tape over empty bolt holes, reduce the time required for decontamination.

13. At the user's discretion, install HI-TRAC top lid bolt plugs and/or apply waterproof tape over any empty bolt holes.

ALARA Note:

Keeping the water level below the top of the MPC prevents splashing during handling.

14. Fill the MPC with either demineralized water or spent fuel pool water to approximately 12 inches below the top of the MPC shell. Refer to Tables 2.1.14 and 2.1.16 for boron concentration requirements.
15. If necessary for plant crane capacity limitations, drain the water from the neutron shield jacket. See Tables 8.1.1 through 8.1.4 as applicable.
16. Place HI-TRAC in the spent fuel pool as follows:

ALARA Note:

The term "Spent Fuel Pool" is used generically to refer to the users designated cask loading location. The optional Annulus Overpressure System is used to provide further protection against MPC external shell contamination during in-pool operations.

- a. If used, fill the Annulus Overpressure System lines and reservoir with demineralized water and close the reservoir valve. Attach the Annulus Overpressure System to the HI-TRAC. See Figure 8.1.14.
- b. Verify spent fuel pool for boron concentration requirements in accordance with Tables 2.1.14 and 2.1.16.
- c. Engage the lift yoke to HI-TRAC lifting trunnions and position HI-TRAC over the cask loading area with the basket aligned to the orientation of the spent fuel racks.

ALARA Note:

Wetting the components that enter the spent fuel pool may reduce the amount of decontamination work to be performed later.

- d. Wet the surfaces of HI-TRAC and lift yoke with plant demineralized water while slowly lowering HI-TRAC into the spent fuel pool.
- e. When the top of the HI-TRAC reaches the elevation of the reservoir, open the Annulus Overpressure System reservoir valve. Maintain the reservoir water level at approximately 3/4 full the entire time the cask is in the spent fuel pool.
- f. Place HI-TRAC on the floor of the cask loading area and disengage the lift yoke. Visually verify that the lift yoke is fully disengaged. Remove the lift yoke from the spent fuel pool while spraying the crane cables and yoke with plant demineralized water.
- g. Observe the annulus seal for signs of air leakage. If leakage is observed (by the steady flow of bubbles emanating from one or more discrete locations) then immediately remove the HI-TRAC from the spent fuel pool and repair or replace the seal.

8.1.4 MPC Fuel Loading

Note:

An underwater camera or other suitable viewing device may be used for monitoring underwater operations.

Note:

When loading MPCs requiring soluble boron, the boron concentration of the water shall be checked in accordance with Tables 2.1.14 and 2.1.16 before and during operations with fuel and water in the MPC.

1. Perform a fuel assembly selection verification using plant fuel records to ensure that only fuel assemblies that meet all the conditions for loading as specified in Section 2.1.9 have been selected for loading into the MPC.

HOLTEC INTERNATIONAL COPYRIGHTED MATERIAL

2. Load the pre-selected fuel assemblies into the MPC in accordance with the approved fuel loading pattern.
3. Perform a post-loading visual verification of the assembly identification to confirm that the serial numbers match the approved fuel loading pattern.

8.1.5 MPC Closure

Note:

The user may elect to use the Lid Retention System (See Figure 8.1.15) to assist in the installation of the MPC lid and lift yoke, and to provide the means to secure the MPC lid in the event of a drop accident during loaded cask handling operations outside of the spent fuel pool. The user is responsible for evaluating the additional weight imposed on the cask, lift yoke, crane and floor prior to use. See Tables 8.1.1 through 8.1.4 as applicable. The following guidance describes installation of the MPC lid using the lift yoke. The MPC lid may also be installed separately.

Depending on facility configuration, users may elect to perform MPC closure operations with the HI-TRAC partially submerged in the spent fuel pool. If opted, operations involving removal of the HI-TRAC from the spent fuel pool shall be sequenced accordingly.

1. Remove the HI-TRAC from the spent fuel pool as follows:
 - a. Visually inspect the MPC lid rigging or Lid Retention System in accordance with site-approved rigging procedures. Attach the MPC lid to the lift yoke so that MPC lid, drain line and trunnions will be in relative alignment. Raise the MPC lid and adjust the rigging so the MPC lid hangs level as necessary.
 - b. Install the drain line to the underside of the MPC lid. See Figure 8.1.17.
 - c. Align the MPC lid and lift yoke so the drain line will be positioned in the MPC drain location and the cask trunnions will also engage. See Figure 8.1.11 and 8.1.17.

ALARA Note:

Pre-wetting the components that enter the spent fuel pool may reduce the amount of decontamination work to be performed later.

- d. Slowly lower the MPC lid into the pool and insert the drain line into the drain access location and visually verify that the drain line is correctly oriented. See Figure 8.1.12.
- e. Lower the MPC lid while monitoring for any hang-up of the drain line. If the drain line becomes kinked or disfigured for any reason, remove the MPC lid and replace the drain line.

Note:

The outer diameter of the MPC lid will seat flush with the top edge of the MPC shell when properly installed. Once the MPC lid is installed, the HI-TRAC /MPC removal from the spent fuel pool should proceed in a continuous manner to minimize the rise in MPC water temperature.

- f. Seat the MPC lid in the MPC and visually verify that the lid is properly installed.
- g. Engage the lift yoke to HI-TRAC lifting trunnions.
- h. Apply a slight tension to the lift yoke and visually verify proper engagement of the lift yoke to the lifting trunnions.

ALARA Note:

Activated debris may have settled on the top face of HI-TRAC and MPC during fuel loading. The cask top surface should be kept under water until a preliminary dose rate scan clears the cask for removal. Users are responsible for any water dilution considerations.

- i. Raise HI-TRAC until the MPC lid is just below the surface of the spent fuel pool. Survey the area above the cask lid to check for hot particles. Remove any activated or highly radioactive particles from HI-TRAC or MPC.
- j. Visually verify that the MPC lid is properly seated. Lower HI-TRAC, reinstall the lid, and repeat as necessary.
- k. Install the Lid Retention System bolts if the lid retention system is used.
- l. Continue to raise the HI-TRAC under the direction of the plant's radiological control personnel. Continue rinsing the surfaces with demineralized water. When the top of the HI-TRAC reaches the same elevation as the reservoir, close the Annulus Overpressure System reservoir valve (if used). See Figure 8.1.14.

Caution:

Users are required to take necessary actions to prevent boiling of the water in the MPC. This may be accomplished by performing a site-specific analysis to identify a time limitation to ensure that water boiling will not occur in the MPC prior to the initiation of draining operations. Chapter 4 of the FSAR provides some sample time limits for the time to initiation of draining for various spent fuel pool water temperatures using design basis heat loads. These time limits may be adopted if the user chooses not to perform a site-specific analysis. If time limitations are imposed, users shall have appropriate procedures and equipment to take action. Users shall initiate a course of action which involves initiating and maintaining forced water circulation at a required flow rate through the MPC. Any site-specific analysis shall identify the methods to respond should it become likely that the imposed time limit could be exceeded. Refer to Tables 2.1.14 and 2.1.16 for boron concentration requirements whenever water is added to the loaded MPC.

- m. Remove HI-TRAC from the spent fuel pool while spraying the surfaces with plant demineralized water. Record the time.

ALARA Note:

Decontamination of HI-TRAC bottom should be performed using remote cleaning methods, covering or other methods to minimize personnel exposure. The bottom lid decontamination may be deferred to a convenient and practical time and location. Any initial decontamination should only be sufficient to preclude spread of contamination within the fuel building.

- n. Decontaminate HI-TRAC bottom and HI-TRAC exterior surfaces including the pool lid bottom. Remove the bottom protective cover, if used.
- o. If used, disconnect the Annulus Overpressure System from the HI-TRAC See Figure 8.1.14.
- p. Set HI-TRAC in the designated cask preparation area.

Note:

If the transfer cask is expected to be operated in an environment below 32 °F, the water jacket shall be filled with an ethylene glycol solution (25% ethylene glycol). Otherwise, the jacket shall be filled with demineralized water. Depending on weight limitations, the neutron shield jacket may remain filled (with pure water or 25% ethylene glycol solution, as required). Users shall evaluate the cask weights to ensure that cask trunnion, lifting devices and equipment load limitations are not exceeded.

- q. If previously drained, fill the neutron shield jacket with plant demineralized water or an ethylene glycol solution (25% ethylene glycol) as necessary.
- r. Disconnect the lifting slings or Lid Retention System (if used) from the MPC lid and disengage the lift yoke. Decontaminate and store these items in an approved storage location.

Warning:

MPC lid dose rates are measured to ensure that dose rates are within expected values. Dose rates exceeding the expected values could indicate that fuel assemblies not meeting the CoC may have been loaded.

- s. Measure the dose rates at the MPC lid and verify that the combined gamma and neutron dose is below expected values.
- t. Perform decontamination and a dose rate/contamination survey of HI-TRAC.
- u. Prepare the MPC annulus for MPC lid welding as follows:

ALARA Note:

If the Temporary Shield Ring is not used, some form of gamma shielding (e.g., lead bricks or blankets) should be placed in the trunnion recess areas of the HI-TRAC water jacket to eliminate the localized hot spot.

- v. Decontaminate the area around the HI-TRAC top flange and install the Temporary Shield Ring, (if used). See Figure 8.1.18.

ALARA Note:

The water in the HI-TRAC-to-MPC annulus provides personnel shielding. The level should be checked periodically and refilled accordingly.

- w. Attach the drain line to the HI-TRAC drain port and lower the annulus water level approximately 6 inches.

2. Prepare for MPC lid welding as follows:

Note:

The following steps use two identical Removable Valve Operating Assemblies (RVOAs) (See Figure 8.1.16) to engage the MPC vent and drain ports. The MPC vent and drain ports are equipped with metal-to-metal seals to minimize leakage during drying, and to withstand the long-term effects of temperature and radiation. The RVOAs allow the vent and drain ports to be operated like valves and prevent the need to hot tap into the penetrations during unloading operations. The RVOAs are purposely not installed until the cask is removed from the spent fuel pool to reduce the amount of decontamination.

Note:

The vent and drain ports are opened by pushing the RVOA operating rod down to engage the drive mechanism on the MPC port connection and turning the operating rod fully in the counter-clockwise direction. The operating rod will not turn once the port is fully open. Similarly, the vent and drain ports are closed by turning the operating rod fully in the clockwise direction. The ports are closed when the operating rod cannot be turned further.

Note:

Steps involving preparation for welding may occur in parallel as long as precautions are taken to prevent contamination of the annulus.

- a. Clean the vent and drain ports to remove any dirt. Install the RVOAs (See Figure 8.1.16) to the vent and drain ports leaving caps open.

ALARA Warning:

Personnel should remain clear of the drain hoses any time water is being pumped or purged from the MPC. Assembly crud, suspended in the water, may create a radiation hazard to workers. Controlling the amount of water pumped from the MPC prior to welding keeps the fuel assembly cladding covered with water yet still allows room for thermal expansion.

Caution:

Personnel shall ensure that the water level is not lowered below the top of the fuel cladding to avoid exposing the fuel to atmosphere to prevent oxidation and potential fuel damage.

- b. Attach the water pump to the drain port (See Figure 8.1.19) and lower the water level to keep moisture away from the weld region.
- c. Disconnect the water pump.

- d. Carefully decontaminate the MPC lid top surface and the shell area above the inflatable seal
- e. Deflate and remove the inflatable annulus seal.

ALARA Note:

The MPC exterior shell survey is performed to evaluate the performance of the inflatable annulus seal. Indications of contamination could require the MPC to be unloaded. In the event that the MPC shell is contaminated, users must decontaminate the annulus. If the contamination cannot be reduced to acceptable levels, the MPC must be returned to the spent fuel pool and unloaded. The MPC may then be removed and the external shell decontaminated.

- f. Survey the MPC lid top surfaces and the accessible areas of the top three inches of the MPC.

ALARA Note:

The annulus shield is used to prevent objects from being dropped into the annulus and helps reduce dose rates directly above the annulus region. The annulus shield is hand installed and requires no tools.

- g. Install the annulus shield. See Figure 8.1.13.

3. Weld the MPC lid as follows:

ALARA Warning:

Grinding of MPC welds may create the potential for contamination. All grinding activities shall be performed under the direction of radiation protection personnel.

ALARA Warning:

It may be necessary to rotate or reposition the MPC lid slightly to achieve uniform weld gap and lid alignment. A punch mark is located on the outer edge of the MPC lid and shell. These marks are aligned with the alignment mark on the top edge of the HI-TRAC Transfer Cask (See Figure 8.1.8). If necessary, the MPC lid lift should be performed using a hand operated chain fall to closely control the lift to allow rotation and repositioning by hand. If the chain fall is hung from the crane hook, the crane should be tagged out of service to prevent inadvertent use during this operation. Continuous radiation monitoring is recommended.

- a. If necessary center the lid in the MPC shell using a hand-operated chain fall.

Note:

The MPC is equipped with lid shims that serve to close the gap in the joint for MPC lid closure weld.

- b. As necessary, install the MPC lid shims around the MPC lid to make the weld gap uniform.

ALARA Note:

The AWS Baseplate shield is used to further reduce the dose rates to the operators working around the top cask surfaces.

- c. Install the Automated Welding System (AWS) baseplate shield. See Figure 8.1.9 for rigging.
- d. If used, install the Automated Welding System Robot.

Note:

It may be necessary to remove the RVOAs to allow access for the automated welding system. In this event, the vent and drain port caps should be opened to allow for thermal expansion of the MPC water.

Note:

Combustible gas monitoring as described in Step 3e and the associated Caution block are required by the HI-STORM 100 CoC (CoC Appendix B (and B-100U), Section 3.8) and may not be deleted without prior NRC approval via CoC amendment.

Caution:

Oxidation of neutron absorber panels contained in the MPC may create hydrogen gas while the MPC is filled with water. Additionally, radiolysis of the water may occur in high flux conditions creating additional combustible gases. Appropriate monitoring for combustible gas concentrations shall be performed prior to, and during MPC lid welding operations per CoC Appendix B (and B-100U), Section 3.8. The space below the MPC lid shall be purged with inert gas prior to, and during MPC lid welding operations to provide additional assurance that flammable gas concentrations will not develop in this space.

- e. Perform combustible gas monitoring and purge the space under the MPC lid with an inert gas to ensure that there is no combustible mixture present in the welding area.
 - f. Perform the MPC lid-to-shell weld and NDE with approved procedures (See 9.1 and Table 2.2.15).
 - g. Deleted.
 - h. Deleted.
 - i. Deleted.
 - j. Deleted.
4. Perform MPC Lid-to-Shell weld pressure testing as follows:

ALARA Note:

Testing is performed before the MPC is drained for ALARA reasons. A weld repair is a lower dose activity if water remains inside the MPC.

- a. If performing a hydrostatic test, attach the drain line to the vent port and route the drain line to the spent fuel pool or the plant liquid radwaste system and connect the pressurized water supply to the drain port. If performing a pneumatic test, attach the pressure supply and vent line to the vent port and route the vent line to a suitable radwaste connection. See Figure 8.1.20 for the pressure test arrangement.

ALARA Warning:
 Water flowing from the MPC may carry activated particles and fuel particles. Apply appropriate ALARA practices around the drain line.

- b. If performing a hydrostatic test, fill the MPC with either spent fuel pool water or plant demineralized water until water is observed flowing out of the vent port drain hose. Refer to Tables 2.1.14 and 2.1.16 for boron concentration requirements.
- c. Perform the pressure test of the MPC as follows:
 - 1. Close the drain/vent valve and pressurize the MPC to minimum test pressure listed in Table 2.0.1 +5/-0 psig.
 - 2. Close the supply valve and monitor the pressure for a minimum of 10 minutes. The pressure shall not drop below the minimum test pressure during the performance of the test.
 - 3. Following the 10-minute hold period, visually examine the MPC lid-to-shell weld for leakage of water (hydrostatic test) or helium using a bubble test solution (pneumatic test). The acceptance criterion is no observable leakage.
- d. Release the MPC internal pressure, disconnect the inlet line and drain line from the vent and drain port RVOAs leaving the vent and drain port caps open.
 - 1. Repeat the liquid penetrant examination on the MPC lid final pass.
- e. Repair any weld defects in accordance with the site's approved weld repair procedures. Re-perform the Ultrasonic (if necessary), PT, and pressure tests if weld repair is performed.

5. Drain the MPC as follows:

Caution:

This Caution block is required by the HI-STORM 100 CoC (CoC Appendix B, Section 3.4.10 and Appendix B-100U, Section 3.4.12) and may not be deleted without prior NRC approval via CoC amendment. To prevent the oxidation of the fuel the MPC interior shall be filled with helium or another suitable inert gas to avoid exposing the fuel to oxidizing agents while at elevated temperatures. Exposing fuel at elevated temperatures to oxidizing agents can lead to deleterious oxidation of the fuel.

Caution:

For MPCs above a threshold heat load (see Technical Specifications), vacuum drying is subject to a time limit starting at completion of this operational step and ending when helium backfill is initiated. Do not begin this step for such an MPC unless intending to proceed shortly thereafter to vacuum drying. In addition, users should ensure procedures for cycling are in place if time limits are applicable. The procedures should include the required backfilling pressure, hold times, and duration of subsequent vacuum drying cycles, understanding that the number of cycles is limited to ten per ISG-11 Rev. 3.

- a. Attach the drain line to the vent port and route the drain line to the spent fuel pool or the plant liquid radwaste system. See Figure 8.1.20.

ALARA Warning:

Water flowing from the MPC may carry activated particles and fuel particles. Apply appropriate ALARA practices around the drain line.

- b. Attach the water fill line to the drain port and fill the MPC with either spent fuel pool water or plant demineralized water until water is observed flowing out of the drain line.
- c. Disconnect the water fill and drain lines from the MPC leaving the vent port valve open to allow for thermal expansion of the MPC water.

ALARA Warning:

Dose rates will rise as water is drained from the MPC. Continuous dose rate monitoring is recommended.

- d. Attach a regulated helium or nitrogen supply to the vent port.
- e. Attach a drain line to the drain port shown on Figure 8.1.21.
- f. Deleted
- g. Verify the correct pressure on the gas supply.
- h. Open the gas supply valve and record the time at the start of MPC draining.

Note:

An optional warming pad may be placed under the HI-TRAC Transfer Cask to replace the heat lost during the evaporation process of MPC drying. This may be used at the user's discretion for older and colder fuel assemblies to reduce vacuum drying times.

- i. Start the warming pad, if used.

Note:

Users may continue to purge the MPC to remove as much water as possible.

- j. Drain the water out of the MPC until water ceases to flow out of the drain line. Shut the gas supply valve. See Figure 8.1.21.
- k. Deleted.

- l. Disconnect the gas supply line from the MPC.
- m. Disconnect the drain line from the MPC.

Note:

Vacuum drying or moisture removal using FHD (for high burn-up fuel or high decay heat) is performed to remove moisture and oxidizing gasses from the MPC. This ensures a suitable environment for long-term storage of spent fuel assemblies and ensures that the MPC pressure remains within design limits. The vacuum drying process described herein reduces the MPC internal pressure in stages. Dropping the internal pressure too quickly may cause the formation of ice in the fittings. Ice formation could result in incomplete removal of moisture from the MPC. The moisture removal process limits bulk MPC temperatures by continuously circulating gas through the MPC. Section 8.1.5 Steps 6a through q are used for the vacuum drying method of drying and backfill. Section 8.1.5 Steps 7a through i are used for the FHD method of drying and backfill.

6. Dry and Backfill the MPC as follows (Vacuum Drying Method):

Note:

During vacuum drying, the annulus between the MPC and the HI-TRAC must be maintained full of water. Water lost due to evaporation or boiling must be replaced to maintain the water level.

- a. Fill the annulus between the MPC and HI-TRAC with clean water. The water level must be within 6" of the top of the MPC.
- b. Attach the drying system (VDS) to the vent and drain port RVOAs. See Figure 8.1.22a. Other equipment configurations that achieve the same results may also be used.

Note:

The vacuum drying system may be configured with an optional fore-line condenser. Other equipment configurations that achieve the same results may be used.

Note:

To prevent freezing of water, the MPC internal pressure should be lowered in incremental steps. The vacuum drying system pressure will remain at about 30 torr until most of the liquid water has been removed from the MPC.

- c. Open the VDS suction valve and reduce the MPC pressure to below 3 torr.
- d. Shut the VDS valves and verify a stable MPC pressure on the vacuum gage.

Note:

The MPC pressure may rise due to the presence of water in the MPC. The dryness test may need to be repeated several times until all the water has been removed. Leaks in the vacuum drying system, damage to the vacuum pump, and improper vacuum gauge calibration may cause repeated failure of the dryness verification test. These conditions should be checked as part of the corrective actions if repeated failure of the dryness verification test is occurring.

- e. Perform the MPC drying pressure test in accordance with the technical specifications. If MPC vacuum drying acceptance criteria are not met during allowable time, backfill the MPC cavity with helium to a pressure of ≥ 0.5 atm and reset the vacuum drying time (see Technical Specifications).
- f. Close the vent and drain port valves.
- g. Disconnect the VDS from the MPC.
- h. Stop the warming pad, if used.
- i. Close the drain port RVOA cap and remove the drain port RVOA.

Note:

Helium backfill shall be in accordance with the Technical Specification using 99.995% (minimum) purity. Other equipment configurations that achieve the same results may be used.

- j. Set the helium bottle regulator pressure to the appropriate pressure.
- k. Purge the Helium Backfill System to remove oxygen from the lines.
- l. Attach the Helium Backfill System to the vent port as shown on Figure 8.1.23 and open the vent port.
- m. Slowly open the helium supply valve while monitoring the pressure rise in the MPC.

Note:

If helium bottles need to be replaced, the bottle valve needs to be closed and the entire regulator assembly transferred to the new bottle.

- n. Carefully backfill the MPC in accordance with the technical specifications
- o. If used, stop the water flow through the annulus between the MPC and HI-TRAC. Drain the water from the annulus
- p. Disconnect the helium backfill system from the MPC.
- q. Close the vent port RVOA and disconnect the vent port RVOA.

7. Dry and Backfill the MPC as follows (FHD Method):

Note:

Helium backfill shall be in accordance with the Technical Specification using 99.995% (minimum) purity. When using the FHD system to perform the MPC helium backfill, the FHD system shall be evacuated or purged and the system operated with 99.995% (minimum) purity helium.

Note:

MPC internal pressure during FHD operation must be ≤ 75 psia, to comply with Technical Specification.

Caution:

MPC internal pressure during FHD operation may be less than the Technical Specification minimum backfill requirement. In the event of an FHD System failure where the MPC internal pressure is below the Technical Specification limit, the MPC must be backfilled to the minimum helium pressure required by the Technical Specification to place the MPC in an acceptable condition.

- a. Attach the moisture removal system to the vent and drain port RVOAs. See Figure 8.1.22b. Other equipment configurations that achieve the same results may also be used.
 - b. Circulate the drying gas through the MPC while monitoring the circulating gas for moisture. Collect and remove the moisture from the system as necessary.
 - c. Continue the monitoring and moisture removal until LCO 3.1.1 is met for MPC dryness.
 - d. Continue operation of the FHD system with the demoinsturizer on.
 - e. While monitoring the temperatures into and out of the MPC, adjust the helium pressure in the MPC to provide a fill pressure as required by the technical specifications.
 - f. Open the FHD bypass line.
 - g. Close the vent and drain port RVOAs.
 - h. Shutdown the FHD system and disconnect it from the RVOAs.
 - i. Remove the vent and drain port RVOAs.
8. Weld the vent and drain port cover plates as follows:

Note:

The process provided herein may be modified to perform actions in parallel.

- a. Wipe the inside area of the vent and drain port recesses to dry and clean the surfaces.
- b. Place the cover plate over the vent port recess.
- c. Deleted.

Note:

ASME Boiler and Pressure Vessel Code [8.1.3], Section V, Article 6 provides the liquid penetrant inspection methods. The acceptance standards for liquid penetrant examination shall be in accordance with ASME Boiler and Pressure Vessel Code, Section III, Subsection NB, Article NB-5350 as specified on the Design Drawings. ASME Code, Section III, Subsection NB, Article NB-4450 provides acceptable requirements for weld repair. NDE personnel shall be qualified per the requirements of Section V of the Code or site-specific program.

- d. Weld cover plate and perform NDE on the cover plate with approved procedures (See 9.1 and Table 2.2.15)
 - e. Repair and weld defects in accordance with the site's approved code weld repair procedures.
 - f. Perform a helium leakage rate test on the cover plate welds. (See 9.1 and Table 2.2.15). Acceptance Criteria are defined in Technical Specification LCO 3.1.1.
 - g. Repair any weld defects in accordance with the site's approved code weld repair procedures.
 - h. Deleted.
 - i. Repeat for the drain port cover plate.
9. Perform a leakage test of the MPC vent and drain port cover plates as follows:

Note:

The leakage detector may detect residual helium in the atmosphere from the helium injection process. If the leakage tests detect a leak, the area should be blown clear with compressed air or nitrogen and the location should be retested.

Note:

The following process provides a high concentration of helium gas in the cavity. Other methods that ensure a high concentration of helium gas are also acceptable.

- a. If necessary, remove the cover plate set screws.
- b. Flush the cavity with helium to remove the air and immediately install the set screws recessed ¼ inch below the top of the cover plate.
- c. Plug weld the recess above each set screw to complete the penetration closure welding.

Note:

ASME Boiler and Pressure Vessel Code [8.1.3], Section V, Article 6 provides the liquid penetrant inspection methods. The acceptance standards for liquid penetrant examination shall be in accordance with ASME Boiler and Pressure Vessel Code, Section III, Subsection NB, Article NB-5350 as specified on the Design Drawings. ASME Code, Section III, Subsection NB, Article NB-4450 provides acceptable requirements for weld repair. NDE personnel shall be qualified per the requirements of Section V of the Code or site-specific program.

- d. Perform a liquid penetrant examination on the plug weld.
- e. Flush the area around the vent and drain cover plates with compressed air or nitrogen to remove any residual helium gas.
- f. Perform a helium leakage rate test of vent and drain cover plate welds in accordance with the Mass Spectrometer Leak Detector (MSLD) manufacturer's instructions and ANSI N14.5 [8.1.2]. The MPC Helium Leak Rate acceptance criteria is provided in the Technical Specification LCO 3.1.1.

- g. Repair any weld defects in accordance with the site's approved code weld repair procedures. Re-perform the leakage test as required.

10. Weld the MPC closure ring as follows:

ALARA Note:

The closure ring is installed by hand. No tools are required. Localized grinding to achieve the desired fit and weld prep are allowed.

- a. Install and align the closure ring. See Figure 8.1.8.
- b. Weld the closure ring to the MPC shell and the MPC lid, and perform NDE with approved procedures (See 9.1 and Table 2.2.15).
- c. Deleted.
- d. Deleted.
- e. Deleted.
- f. Deleted.
- g. Deleted.
- h. Deleted.
- i. Deleted.
- j. If necessary, remove the AWS. See Figure 8.1.7 for rigging.

8.1.6 Preparation for Storage

ALARA Warning:

Dose rates will rise around the top of the annulus as water is drained from the annulus. Apply appropriate ALARA practices.

Caution:

Limitations for the handling an MPC containing high burn-up fuel in a HI-TRAC are evaluated and established on a canister basis to ensure that acceptable cladding temperatures are not exceeded. Refer to FSAR Section 4.5 for guidance.

Note:

For an MPC containing high burn-up fuel assemblies and MPC heat load greater than the threshold heat load setting in Table 4.5.4, the Supplemental Cooling System is required to be operated within LCO 3.1.4 time limits following completion of backfill (see Section 4.5). In the event of a Supplemental Cooling System failure, a HI-TRAC in a horizontal orientation must be placed into a vertical orientation within 24 hours.

1. Remove the annulus shield (if used) and store it in an approved plant storage location
2. If use of the SCS is not required, attach a drain line to the HI-TRAC and drain the remaining water from the annulus to the spent fuel pool or the plant liquid radwaste system.
3. Install HI-TRAC top lid as follows:

Warning:

When traversing the MPC with the HI-TRAC top lid using non-single-failure proof (or equivalent safety factors), the lid shall be kept less than 2 feet above the top surface of the MPC. This is performed to protect the MPC lid from a potential lid drop.

- a. Install HI-TRAC top lid. Inspect the bolts for general condition. Replace worn or damaged bolts with new bolts.
 - b. Install and torque the top lid bolts. See Table 8.1.5 for torque requirements.
 - c. Inspect the lift cleat bolts for general condition. Replace worn or damaged bolts with new bolts.
 - d. Install the MPC lift cleats and MPC slings. See Figure 8.1.24 and 8.1.25. See Table 8.1.5 for torque requirements.
 - e. Drain and remove the Temporary Shield Ring, if used.
4. Replace the pool lid with the transfer lid as follows (Not required for HI-TRAC 100D and 125D):

ALARA Note:

The transfer slide is used to perform the bottom lid replacement and eliminate the possibility of directly exposing the bottom of the MPC. The transfer slide consists of the guide rails, rollers, transfer step and carriage. The transfer slide carriage and jacks are powered and operated by remote control. The carriage consists of short-stroke hydraulic jacks that raise the carriage to support the weight of the bottom lid. The transfer step produces a tight level seam between the transfer lid and the pool lid to minimize radiation streaming. The transfer slide jacks do not have sufficient lift capability to support the entire weight of the HI-TRAC. This was selected specifically to limit floor loads. Users should designate a specific area that has sufficient room and support for performing this operation.

Note:

The following steps are performed to pretension the MPC slings.

- a. Lower the lift yoke and attach the MPC slings to the lift yoke. See Figure 8.1.25.
- b. Raise the lift yoke and engage the lift yoke to the HI-TRAC lifting trunnions.
- c. If necessary, position the transfer step and transfer lid adjacent to one another on the transfer slide carriage. See Figure 8.1.26. See Figure 8.1.9 for transfer step rigging.
- d. Deleted.
- e. Position HI-TRAC with the pool lid centered over the transfer step approximately one inch above the transfer step.
- f. Raise the transfer slide carriage so the transfer step is supporting the pool lid bottom. Remove the bottom lid bolts and store them temporarily.

HOLTEC INTERNATIONAL COPYRIGHTED MATERIAL

ALARA Warning:

Clear all personnel away from the immediate operations area. The transfer slide carriage and jacks are remotely operated. The carriage has fine adjustment features to allow precise positioning of the lids.

- g. Lower the transfer carriage and position the transfer lid under HI-TRAC.
- h. Raise the transfer slide carriage to place the transfer lid against the HI-TRAC bottom lid bolting flange.
- i. Inspect the transfer lid bolts for general condition. Replace worn or damaged bolts with new bolts.
- j. Install the transfer lid bolts. See Table 8.1.5 for torque requirements.
- k. Raise and remove the HI-TRAC from the transfer slide.
- l. Disconnect the MPC slings and store them in an approved plant storage location.

Warning:

HI-TRAC dose rates are measured to ensure they are within expected values. Dose rates exceeding the expected values could indicate that fuel assemblies not meeting the CoC may have been loaded.

- 5. Perform the HI-TRAC surface dose rate measurements in accordance with the technical specifications. Measured dose rates must be compared with calculated dose rates that are consistent with the calculated doses that demonstrate compliance with the dose limits of 10 CFR 72.104(a).

Note:

HI-STORM receipt inspection and preparation may be performed independent of procedural sequence.

- 6. Perform a HI-STORM receipt inspection and cleanliness inspection in accordance with a site-approved inspection checklist, if required. See Figure 8.1.27 for HI-STORM lid rigging.

Note:

MPC transfer may be performed in the truck bay area, at the ISFSI, or any other location deemed appropriate by the licensee. The following steps describe the general transfer operations (See Figure 8.1.28). The HI-STORM may be positioned on an air pad, roller skid in the cask receiving area or at the ISFSI. The HI-STORM or HI-TRAC may be transferred to the ISFSI using a heavy haul transfer trailer, special transporter or other equipment specifically designed for such a function (See Figure 8.1.29) as long as the HI-TRAC and HI-STORM lifting requirements are not exceeded (See technical specifications). The licensee is responsible for assessing and controlling floor loading conditions during the MPC transfer operations. Installation of the lid, vent screen, and other components may vary according to the cask movement methods and location of MPC transfer.

8.1.7 Placement of HI-STORM into Storage

1. Position an empty HI-STORM module at the designated MPC transfer location. The HI-STORM may be positioned on the ground, on a de-energized air pad, on a roller skid, on a flatbed trailer or other special device designed for such purposes. If necessary, remove the exit vent screens and gamma shield cross plates, temperature elements and the HI-STORM lid. See Figure 8.1.28 for some of the various MPC transfer options.
 - a. Rinse off any road dirt with water. Inspect all cavity locations for foreign objects. Remove any foreign objects.
 - b. Transfer the HI-TRAC to the MPC transfer location.
2. De-energize the air pad or chock the vehicle wheels to prevent movement of the HI-STORM during MPC transfer and to maintain level, as required.

ALARA Note:

The HI-STORM vent duct shield inserts eliminate the streaming path created when the MPC is transferred past the exit vent ducts. Vent duct shield inserts are not used with the HI-STORM 100S.

3. Install the alignment device (or mating device for HI-TRAC 100D and 125D) and if necessary, install the HI-STORM vent duct shield inserts. See Figure 8.1.30.

Caution:

MPCs loaded with high burn-up fuel and MPC heat load greater than the threshold heat load defined in Table 4.5.4 require operation of the supplemental cooling system to prevent fuel cladding temperatures in excess of ISG-11 Rev. 3 limits. (See Section 4.5) All preparatory work related to the transfer should be completed prior to terminating the supplemental cooling operations.

4. If used, discontinue the supplemental cooling operations and disconnect the SCS. Drain water from the HI-TRAC annulus to an appropriate plant discharge point.
5. Position HI-TRAC above HI-STORM. See Figure 8.1.28.
6. Align HI-TRAC over HI-STORM (See Figure 8.1.31) and mate the overpacks.
7. If necessary, attach the MPC Downloader. See Figure 8.1.32.
8. Attach the MPC slings to the MPC lift cleats.
9. Raise the MPC slightly to remove the weight of the MPC from the transfer lid doors (or pool lid for HI-TRAC 100D and 125D and mating device)
10. If using the HI-TRAC 100D or 125D, unbolt the pool lid from the HI-TRAC.
11. Remove the transfer lid door (or mating device drawer) locking pins and open the doors (or drawer).

HOLTEC INTERNATIONAL COPYRIGHTED MATERIAL

ALARA Warning:

MPC trim plates are used to eliminate the streaming path above and below the doors (or drawer). If trim plates are not used, personnel should remain clear of the immediate door area during MPC downloading since there may be some radiation streaming during MPC raising and lowering operations.

12. At the user's discretion, install trim plates to cover the gap above and below the door/drawer. The trim plates may be secured using hand clamps or any other method deemed suitable by the user. See Figure 8.1.33.
13. Lower the MPC into HI-STORM.
14. Disconnect the slings from the MPC lifting device and lower them onto the MPC lid.
15. Remove the trim plates (if used), and close the doors (or mating device drawer)

ALARA Warning:

Personnel should remain clear (to the maximum extent practicable) of the HI-STORM annulus when HI-TRAC is removed due to radiation streaming.

Note:

It may be necessary, due to site-specific circumstances, to move HI-STORM from under the empty HI-TRAC to install the HI-STORM lid, while inside the Part 50 facility. In these cases, users shall evaluate the specifics of their movements within the requirements of their Part 50 license.

16. Remove HI-TRAC from on top of HI-STORM.
17. Remove the MPC lift cleats and MPC slings and install hole plugs in the empty MPC bolt holes. See Table 8.1.5 for torque requirements.
18. Place HI-STORM in storage as follows:
 - a. Remove the alignment device (mating device with HI-TRAC pool lid for HI-TRAC 100D and 125D) and vent duct shield inserts (if used). See Figure 8.1.30.
 - b. Inspect the HI-STORM lid studs and nuts or lid closure bolts for general condition. Replace worn or damaged components with new ones.
 - c. If used, inspect the HI-STORM 100A anchor components for general condition. Replace worn or damaged components with new ones.
 - d. Deleted.

Warning:

Unless the lift is single failure proof (or equivalent safety factor) for the HI-STORM Lid, the lid shall be kept less than 2 feet above the top surface of the overpack. This is performed to protect the MPC lid from a potential HI-STORM 100 lid drop.

Note:

Shims may be used on the HI-STORM 100 lid studs. If used, the shims shall be positioned to ensure a radial gap of less than 1/8 inch around each stud. The method of cask movement will determine the most effective sequence for vent screen, lid, temperature element, and vent gamma shield cross plate installation.

- e. Install the HI-STORM lid and the lid studs and nuts or lid closure bolts. See Table 8.1.5 for bolting requirements. Install the HI-STORM 100 lid stud shims if necessary. See Figure 8.1.27 for rigging.
- f. Install the HI-STORM exit vent gamma shield cross plates, temperature elements (if used) and vent screens. See Table 8.1.5 for torque requirements. See Figure 8.1.34a.
- g. Remove the HI-STORM lid lifting device and install the hole plugs in the empty holes. Store the lifting device in an approved plant storage location. See Table 8.1.5 for torque requirements.

Warning:

HI-STORM dose rates are measured to ensure they are within expected values. Dose rates exceeding the expected values could indicate that fuel assemblies not meeting the CoC may have been loaded.

- h. Perform the HI-STORM surface dose rate measurements in accordance with the technical specifications. Measured dose rates must be compared with calculated dose rates that are consistent with the calculated doses that demonstrate compliance with the dose limits of 10 CFR 72.104(a).
- i. Secure HI-STORM to the transporter device as necessary.

Note:

The site-specific transport route conditions must satisfy the requirements of the technical specification.

- 19. Perform a transport route walkdown to ensure that the cask transport conditions are met.
- 20. Transfer the HI-STORM to its designated storage location at the appropriate pitch. See Figure 8.1.35.

Note:

Any jacking system shall have the provisions to ensure uniform loading of all four jacks during the lifting operation.

- a. If air pads were used, insert the HI-STORM lifting jacks and raise HI-STORM. See Figure 8.1.36. Remove the air pad.
- b. Lower and remove the HI-STORM lifting jacks, if used.

- c. For HI-STORM 100A overpack (anchored), perform the following:
 1. Inspect the anchor stud receptacles and verify that they are clean and ready for receipt of the anchor hardware.
 2. Align the overpack over the anchor location.
 3. Lower the overpack to the ground while adjusting for alignment.
 4. Install the anchor connecting hardware (See Table 8.1.5 for torque requirements).
21. Install the HI-STORM inlet vent gamma shield cross plates and vent screens. See Table 8.1.5 for torque requirements. See Figure 8.1.34.
22. Perform an air temperature rise test as follows for the first HI-STORM 100 System placed in service:

Note:

The air temperature rise test shall be performed between 5 and 7 days after installation of the HI-STORM 100 lid to allow thermal conditions to stabilize. The purpose of this test is to confirm the initial performance of the HI-STORM 100 ventilation system.

- a. Measure the inlet air (or screen surface) temperature at the center of each of the four vent screens. Determine the average inlet air (or surface screen) temperature.
 - b. Measure the outlet air (or screen surface) temperature at the center of each of the four vent screens. Determine the average outlet air (or surface screen) temperature.
 - c. Determine the average air temperature rise by subtracting the results of the average inlet screen temperature from the average outlet screen temperature.
 - d. Report the results to the certificate holder.
23. Users who load to CoC Amendment 5 with a heat load greater than 20kW must perform the following annular air flow thermal test or cite a test report that was performed and prepared by another User. This test is required to be performed once per CoC Condition 9.
 - a. The annular air flow thermal test shall be conducted at least 7 days after the HI-STORM is loaded in order for the overpack to establish thermal equilibrium.
 - b. The User or other qualified engineer shall calculate and record the actual heat load of the fuel stored in the HI-STORM.
 - c. To minimize the effects on the annular air flow, the test shall be performed when the weather is relatively dry and calm.
 - d. The ambient air temperature at the cask shall be recorded
 - e. The test data shall be collected for the annular flow as follows:

1. The outlet vent screen and gamma shield shall be removed from one outlet vent.
 2. A hot wire anemometer or similar flow measuring instrument shall be inserted into the annular space between the MPC and HI-STORM inner shell.
 3. The flow measuring instrument shall be positioned at least 6" below the top of the MPC and shall not significantly block the air flow.
 4. The instrument shall not be placed too close to the MPC or HI-STORM shells to avoid edge effects on the flow.
 5. The outlet gamma shield and vent screen shall be re-installed.
 6. Measurements of the air flow shall be taken and recorded for a minimum of three places radially across the annular gap.
 7. The outlet vent screen and gamma shield shall be removed from the outlet vent and the flow measuring instrument removed.
 8. The outlet gamma shield and vent screen shall be re-installed.
- f. Air flow in each of the three remaining outlet vents shall be measured and recorded in accordance with step 23.e above.
- g. All test data shall be transmitted to the General Licensee for evaluation and validation of the thermal model.
- h. Users shall forward test and analysis results to the NRC in accordance with 10 CFR 72.4.

Table 8.1.1
ESTIMATED HANDLING WEIGHTS OF HI-STORM 100 SYSTEM COMPONENTS
125-TON HI-TRAC**

Component	MPC-24 (Lbs.)	MPC-32 (Lbs.)	MPC-68 (Lbs.)	Case† Applicability					
				1	2	3	4	5	6
Empty HI-STORM 100 overpack (without lid)††	245,040	245,040	245,040						1
HI-STORM 100 lid (without rigging)	23,963	23,963	23,963						1
Empty HI-STORM 100S (Short) overpack (without lid)††	275,000	275,000	275,000						1
Empty HI-STORM 100S (Tall) overpack (without lid)††	290,000	290,000	290,000						1
HI-STORM 100S lid (without rigging. Add 1,000 lbs for 100S Version B Lid)	28,000	28,000	28,000						1
Empty MPC (without lid or closure ring including drain line)	29,845	24,503	29,302	1	1	1	1	1	1
MPC lid (without fuel spacers or drain line)	9,677	9,677	10,194	1	1	1	1	1	1
MPC Closure Ring	145	145	145			1	1	1	1
Fuel (design basis)	41,280	55,040	49,640	1	1	1	1	1	1
Damaged Fuel Container (Dresden 1)	0	0	150						
Damaged Fuel Container (Humboldt Bay)	0	0	120						
MPC water (with fuel in MPC)	17,630	17,630	16,957	1	1				
Annulus Water	256	256	256	1	1				
HI-TRAC Lift Yoke (with slings)	4,200	4,200	4,200	1	1	1			
Annulus Seal	50	50	50	1	1				
Lid Retention System	2,300	2,300	2,300						
Transfer frame	6,700	6,700	6,700						1
Mating Device	15,000	15,000	15,000						
Empty HI-TRAC 125 (without Top Lid, neutron shield jacket water, or bottom lids)	117,803	117,803	117,803	1	1	1			1
Empty HI-TRAC 125D (without Top Lid, neutron shield jacket water, or bottom lids)	122,400	122,400	122,400	1	1	1			1
HI-TRAC 125 Top Lid	2,745	2,745	2,745			1			1
HI-TRAC 125D Top Lid	2,645	2,645	2,645			1			1
Optional HI-TRAC Lid Spacer (weight lbs/in thickness)	400	400	400						
HI-TRAC 125/125D Pool Lid(with bolts)	11,900	11,900	11,900	1	1				
HI-TRAC Transfer Lid (with bolts) (125 Only)	23,437	23,437	23,437			1			1
HI-TRAC 125 Neutron Shield Jacket Water	8,281	8,281	8,281		1	1			1
HI-TRAC 125 D Neutron Shield Jacket Water	9,000	9,000	9,000		1	1			1
MPC Stays (total of 2)	200	200	200						
MPC Lift Cleat	480	480	480			1	1		1

** Actual component weights are dependant upon as-built dimensions. The values provided herein are estimated. FSAR analyses use bounding values provided elsewhere. Users are responsible for ensuring lifted loads meet site capabilities and requirements.

† See Table 8.1.2 for a description of each load handling case.

†† Short refers to both 100S-232 and 100S Version B-219. Tall refers to both 100S-243 and 100S Version B-229. Weights are based on 200 lb/cf concrete. Add an additional 1955 lbs. for the HI-STORM 100A overpack.

HOLTEC INTERNATIONAL COPYRIGHTED MATERIAL

TABLE 8.1.2
ESTIMATED HANDLING WEIGHTS
125-TON HI-TRAC**

Caution:

The maximum weight supported by the 125-Ton HI-TRAC lifting trunnions cannot exceed 250,000 lbs. Users must take actions to ensure that this limit is not exceeded.

Note:

The weight of the fuel spacers and the damaged fuel container are less than the weight of the design basis fuel assembly for each MPC and are therefore not included in the maximum handling weight calculations. Fuel spacers are determined to be the maximum combination weight of fuel + spacer. Users should determine their specific handling weights based on the MPC contents and the expected handling modes.

Case No.	Load Handling Evolution	Weight (lbs)		
		MPC-24	MPC-32	MPC-68
1	Loaded HI-TRAC 125 removal from spent fuel pool (neutron tank empty)	232,641	241,059	240,302
2	Loaded HI-TRAC 125 removal from spent fuel pool (neutron tank full)	240,992	249,340	248,583
3	Loaded HI-TRAC 125 During Movement through Hatchway	237,893	246,311	246,227
1A	Loaded HI-TRAC 125D removal from spent fuel pool (neutron tank empty)	237,238	245,656	244,899
2A	Loaded HI-TRAC 125D removal from spent fuel pool (neutron tank full)	246,238	254,656	253,899
3A	Loaded HI-TRAC 125D During Movement through Hatchway	231,572	239,990	239,906
4	MPC during transfer operations	81,427	89,595	89,761
5A	Loaded HI-STORM 100 in storage (See Second Note to Table 8.1.1)	349,950	358,368	358,284
5B	Loaded HI-STORM 100S (Short) in storage (See Second Note to Table 8.1.1)	383,947	392,365	392,281
5C	Loaded HI-STORM 100S (Tall) in storage (See Second Note to Table 8.1.1)	398,947	407,365	407,281
6	Loaded HI-TRAC and transfer frame during on site handling	240,393	248,811	248,727

** Actual component weights are dependant upon as-built dimensions. The values provided herein are estimated. FSAR analyses use bounding values provided elsewhere. Users are responsible for ensuring lifted loads meet site capabilities and requirements.

Table 8.1.3
ESTIMATED HANDLING WEIGHTS OF HI-STORM 100 SYSTEM COMPONENTS
100-TON HI-TRAC**

Component	MPC-24 (Lbs.)	MPC-32 (Lbs.)	MPC-68 (Lbs.)	Case [†] Applicability					
				1	2	3	4	5	6
Empty HI-STORM 100 overpack (without lid) ^{††}	245,040	245,040	245,040						1
HI-STORM 100 lid (without rigging)	23,963	23,963	23,963						1
Empty HI-STORM 100S (Short) overpack (without lid) ^{††}	275,000	275,000	275,000						1
Empty HI-STORM 100S (Tall) overpack (without lid) ^{††}	290,000	290,000	290,000						1
HI-STORM 100S lid (without rigging, add 1,000 lbs for 100S Version B Lid)	28,000	28,000	28,000						
Empty MPC (without lid or closure ring including drain line)	29,845	24,503	29,302	1	1	1	1	1	1
MPC lid (without fuel spacers or drain line)	9,677	9,677	10,194	1	1	1	1	1	1
MPC Closure Ring	145	145	145			1	1	1	1
Fuel (design basis)	41,280	55,040	49,640	1	1	1	1	1	1
Damaged Fuel Container (Dresden 1)	0	0	150						
Damaged Fuel Container (Humboldt Bay)	0	0	120						
MPC water (with fuel in MPC)	17,630	17,630	16,957	1	1				
Annulus Water	256	256	256	1	1				
HI-TRAC Lift Yoke (with slings)	3,200	3,200	3,200	1	1	1			
Annulus Seal	50	50	50	1	1				
Lid Retention System	2,300	2,300	2,300						
Transfer frame	6,700	6,700	6,700						1
Empty HI-TRAC 100 (without Top Lid, neutron shield jacket water, or bottom lids)	84,003	84,003	84,003	1	1	1			1
HI-TRAC 100 Top Lid	1,189	1,189	1,189			1			1
HI-TRAC 100 Pool Lid	7,863	7,863	7,863	1	1				
HI-TRAC Transfer Lid (HI-TRAC 100 only)	16,686	16,686	16,686			1			1
Empty HI-TRAC 100D (without Top Lid, neutron shield jacket water, or pool lid)	84,204	84,204	84,204	1	1	1			1
HI-TRAC 100D Top Lid	1,239	1,239	1,239			1			1
HI-TRAC 100D Pool Lid	7,955	7,955	7,955	1	1	1			
Mating Device (HI-TRAC 100D only)	15,000	15,000	15,000						
HI-TRAC 100 Neutron Shield Jacket Water	7,583	7,583	7,583		1	1			1
HI-TRAC 100D Neutron Shield Jacket Water	7,800	7,800	7,800		1	1			1
MPC Stays (total of 2)	200	200	200						
MPC Lift Cleat	480	480	480				1		1

** Actual component weights are dependant upon as-built dimensions. The values provided herein are estimated. FSAR analyses use bounding values provided elsewhere. Users are responsible for ensuring lifted loads meet site capabilities and requirements.

† See Table 8.1.4 for a description of each load handling case.

†† Short refers to both 100S-232 and 100S Version B-219. Tall refers to both 100S-243 and 100S Version B-229. Weights are based on 200 lb/cf concrete. Add an additional 1955 lbs. for the HI-STORM 100A overpack.

HOLTEC INTERNATIONAL COPYRIGHTED MATERIAL

HI-STORM FSAR
REPORT HI-2002444

8.1-34

Rev. 12

HI-STORM 100 FSAR, NON-PROPRIETARY
REVISION 12
MARCH 12, 2014

Table 8.1.4
ESTIMATED HANDLING WEIGHTS
100-TON HI-TRAC**

Caution:

The maximum weight supported by the 100-Ton HI-TRAC lifting trunnions cannot exceed 200,000 lbs. Users must take actions to ensure that this limit is not exceeded.

Note:

The weight of the fuel spacers and the damaged fuel container are less than the weight of the design basis fuel assembly and therefore not included in the maximum handling weight calculations. Fuel spacers are determined to be the maximum combination weight of fuel + spacer. Users should determine the handling weights based on the contents to be loaded and the expected mode of operations.

Case No.	Load Handling Evolution	Weight (lbs)		
		MPC-24	MPC-32	MPC-68
1	Loaded HI-TRAC 100 removal from spent fuel pool (neutron tank empty)	193,804	202,222	201,465
2	Loaded HI-TRAC 100 removal from spent fuel pool (neutron tank full)	201,387	209,805	209,048
3	Loaded HI-TRAC 100 During Movement through Hatchway	193,608	202,026	201,942
1A	Loaded HI-TRAC 100D removal from spent fuel pool (neutron tank empty)	194,097	202,515	201,758
2A	Loaded HI-TRAC 100D removal from spent fuel pool (neutron tank full)	201,897	210,315	209,558
3A	Loaded HI-TRAC 100D During Movement through Hatchway	183,345	193,763	193,679
4	MPC during transfer operations	81,427	89,845	89,761
5A	Loaded HI-STORM 100 in storage (See Second Note to Table 8.1.1)	349,950	358,368	358,284
5B	Loaded HI-STORM 100S (Short) in storage (See Second Note to Table 8.1.1)	383,947	392,365	392,281
5C	Loaded HI-STORM 100S (Tall) in storage (See Second Note to Table 8.1.1)	398,947	407,365	407,281
6	Loaded HI-TRAC 100 and transfer frame during on site handling	197,588	206,006	205,922

** Actual component weights are dependant upon as-built dimensions. The values provided herein are estimated. FSAR analyses use bounding values provided elsewhere. Users are responsible for ensuring lifted loads meet site capabilities and requirements.

Table 8.1.5
HI-STORM 100 SYSTEM TORQUE REQUIREMENTS

Fastener[†]	Torque (ft-lbs)^{††}	Pattern^{†††}
HI-TRAC Top Lid Bolts [†]	Hand tight	None
HI-TRAC Pool Lid Bolts (36 Bolt Lid) [†]	Wrench tight	Figure 8.1.37
HI-TRAC Pool Lid Bolts (16 Bolt Lid) [†]	Wrench tight	Figure 8.1.37
100-Ton HI-TRAC Transfer Lid Bolts [†]	Wrench tight	Figure 8.1.37
125-Ton HI-TRAC Transfer Lid Bolts [†]	Wrench tight	Figure 8.1.37
MPC Lift Cleats Stud Nuts [†]	Wrench tight	None
MPC Lift Hole Plugs [†]	Hand tight	None
Threaded Fuel Spacers	Hand Tight	None
HI-STORM Lid Nuts [†]	Hand tight	None
HI-STORM 100S Lid Nuts and Lid Closure Bolts [†] (Temporary and Permanent Lids, Including Version B)	Hand Tight	None
Door Locking Pins	Hand Tight + 1/8 to 1/2 turn	None
HI-STORM 100 Vent Screen/Temperature Element Screws	Hand Tight	None
HI-STORM 100A Anchor Studs	55- 65 ksi tension applied by bolt tensioner (no initial torque)	None

[†] Studs and nuts shall be cleaned and inspected for damage or excessive thread wear (replace if necessary) and coated with a light layer of Fel-Pro Chemical Products, N-5000, Nuclear Grade Lubricant (or equivalent).

^{††} Unless specifically specified, torques have a +/- 5% tolerance.

^{†††} No detorquing pattern is needed.

HOLTEC INTERNATIONAL COPYRIGHTED MATERIAL

HI-STORM FSAR
REPORT HI-2002444

8.1-36

Rev. 12

HI-STORM 100 FSAR, NON-PROPRIETARY
REVISION 12
MARCH 12, 2014

Table 8.1.6
HI-STORM 100 SYSTEM ANCILLARY EQUIPMENT OPERATIONAL DESCRIPTION

Equipment	Important To Safety Classification	Reference Figure [†]	Description
Air Pads/Rollers	Not Important To Safety	8.1.29	Used for HI-STORM or HI-TRAC cask positioning. May be used in conjunction with the cask transporter or other HI-STORM 100 or HI-TRAC lifting device.
Annulus Overpressure System	Not Important To Safety	8.1.14	The Annulus Overpressure System is used for protection against spent fuel pool water contamination of the external MPC shell and baseplate surfaces by providing a slight annulus overpressure during in-pool operations.
Annulus Shield	Not Important To Safety	8.1.13	A shield that is placed at the top of the HI-TRAC annulus to provide supplemental shielding to the operators performing cask loading and closure operations.
Automated Welding System	Not Important To Safety	8.1.2b	Used for remote field welding of the MPC.
AWS Baseplate Shield	Not Important To Safety	8.1.2b	Provides supplemental shielding to the operators during the cask closure operations.
Bottom Lid Transfer Slide (Not used with HI-TRAC 100D and 125D)	Not Important To Safety	8.1.26	Used to simultaneously replace the pool lid with the transfer lid under the suspended HI-TRAC and MPC. Used in conjunction with the bottom lid transfer step.
Cask Transporter	Not Important to Safety unless used for MPC transfers	8.1.29a and 8.1.29b	Used for handling of the HI-STORM 100 Overpack and/or the HI-TRAC Transfer Cask around the site. The cask transporter may take the form of heavy haul transfer trailer, special transporter or other equipment specifically designed for such a function. May also be used for MPC transfers (examples are shown in Figure 8.1.28).

[†] Figures are representative and may not depict all configurations for all users.

Table 8.1.6
HI-STORM 100 SYSTEM ANCILLARY EQUIPMENT OPERATIONAL DESCRIPTION
(Continued)

Equipment	Important To Safety Classification	Reference Figure [†]	Description
Lid and empty component lifting rigging	Not Important To Safety, Rigging shall be provided in accordance with NUREG 0612	8.1.9	Used for rigging such components such as the HI-TRAC top lid, pool lid, MPC lid, transfer lid, AWS, HI-STORM Lid and auxiliary shielding and the empty MPC.
Helium Backfill System	Not Important To Safety	8.1.23	Used for controlled insertion of helium into the MPC for pressure testing, blowdown and placement into storage.
HI-STORM 100 Lifting Jacks	Not Important To Safety	8.1.36	Jack system used for lifting the HI-STORM overpack to provide clearance for inserting or removing a device for transportation.
Alignment Device	Not Important To Safety	8.1.31	Guides HI-TRAC into place on top of HI-STORM for MPC transfers. (Not used for HI-TRAC 100D and 125D)
HI-STORM Lifting Devices	Determined site-specifically based on type, location, and height of lift being performed. Lifting devices shall be provided in accordance with ANSI N14.6.	Not shown.	A special lifting device used for connecting the crane (or other primary lifting device) to the HI-STORM 100 for cask handling. Does not include the crane hook (or other primary lifting device) device.
HI-STORM Vent Duct Shield Inserts	Important to Safety Category C .	8.1.30	Used for prevention of radiation streaming from the HI-STORM 100 exit vents during MPC transfers to and from HI-STORM. Not used with the HI-STORM 100S.
HI-TRAC Lid Spacer	Spacer Ring is Not-Important-To-Safety, Studs or bolts are I Important to Safety Category B	Not Shown	Optional ancillary which is used during MPC transfer operations to increase the clearance between the top of the MPC and the underside of the HI-TRAC top lid. Longer threaded studs (or bolts), supplied with the lid spacer, replace the standard threaded studs (or bolts) supplied with the HI-TRAC. The HI-TRAC lid spacer may ONLY be used when the HI-TRAC is handled in the vertical orientation or if HI-TRAC transfer lid is NOT used. The height of the spacer shall be limited to ensure that the weights and C.G. heights in a loaded HI-TRAC with the spacer do not exceed the bounding values found in Section 3.2 of the FSAR.
HI-TRAC Lift Yoke/Lifting Links	Determined site-specifically based on type and location, and height of lift being performed. Lift yoke and lifting devices for loaded HI-TRAC handling shall be provided in accordance with ANSI N14.6.	8.1.3	Used for connecting the crane (or other primary lifting device) to the HI-TRAC for cask handling. Does not include the crane hook (or other primary lifting device).

[†] Figures are representative and may not depict all configurations for all users.

Table 8.1.6
HI-STORM 100 SYSTEM ANCILLARY EQUIPMENT OPERATIONAL DESCRIPTION (Continued)

Equipment	Important To Safety Classification	Reference Figure [†]	Description
HI-TRAC transfer frame	Not Important To Safety	8.1.4	A steel frame used to support HI-TRAC during delivery, on-site movement and upending/downending operations.
Cask Primary Lifting Device (Cask Transfer Facility)	Important to Safety. Quality classification of subcomponents determined site-specifically.	8.1.28 and 8.1.32	Optional auxiliary (Non-Part 50) cask lifting device(s) used for cask upending and downending and HI-TRAC raising for positioning on top of HI-STORM to allow MPC transfer. The device may consist of a crane, lifting platform, gantry system or any other suitable device used for such purpose.
Inflatable Annulus Seal	Not Important To Safety	8.1.13	Used to prevent spent fuel pool water from contaminating the external MPC shell and baseplate surfaces during in-pool operations.
Lid Retention System	Important to Safety Status determined by each licensee. MPC lid lifting portions of the Lid Retention System shall meet the requirements of ANSI N14.6.	8.1.15, 8.1.17	Optional. The Lid Retention System secures the MPC lid in place during cask handling operations between the pool and decontamination pad.
MPC Lift Cleats	Important To Safety – Category A. MPC Lift Cleats shall be provided in accordance with of ANSI N14.6.	8.1.24	MPC lift cleats consist of the cleats and attachment hardware. The cleats are supplied as solid steel components that contain no weds. The MPC lift cleats are used to secure the MPC inside HI-TRAC during bottom lid replacement and support the MPC during MPC transfer from HI-TRAC into HI-STORM and vice versa. The ITS classification of the lifting device attached to the cleats may be lower than the cleat itself, as determined site-specifically.
Pressure Test System	Not Important to Safety	8.1.20	Used to pressure test the MPC lid-to-shell weld.
MPC Downloader	Important To Safety status determined site-specifically. MPC Downloader Shall meet the requirements of CoC, Appendix B, Section 3.5 for aboveground systems and Appendix A-100U, Section 5.5 for underground systems.	8.1.28 and 8.1.32	A lifting device used to help raise and lower the MPC during MPC transfer operations to limit the lift force of the MPC against the top lid of HI-TRAC. The MPC downloader may take several forms depending on the location of MPC transfer and may be used in conjunction with other lifting devices.

[†] Figures are representative and may not depict all configurations for all users.

Table 8.1.6
HI-STORM 100 SYSTEM ANCILLARY EQUIPMENT OPERATIONAL DESCRIPTION (Continued)

Equipment	Important To Safety Classification	Reference Figure [†]	Description
Deleted			
Deleted			
Mating Device	Important-To-Safety – Category B	8.1.31	Used to mate HI-TRAC 100D and 125D to HI-STORM during transfer operations. Includes sliding drawer for use in removing HI-TRAC pool lid.
MPC Support Slings	Important To Safety – Category A – Rigging shall be provided in accordance with NUREG 0612.	8.1.25	Used to secure the MPC to the lift yoke during HI-TRAC bottom lid replacement operations. Attaches between the MPC lift cleats and the lift yoke. Can be configured for different crane hook configuration.
MPC Upending Frame	Not Important to Safety	8.1.6	A steel frame used to evenly support the MPC during upending operations, and control the upending process.
Supplemental Cooling System	Important to Safety – Category B	2.C.1	A system used to circulate water or other coolant through the HI-TRAC annulus in order to maintain fuel cladding temperatures below ISG-11 Rev. 3 limits during operations with the MPC in the HI-TRAC. Required only for MPC containing high burn-up fuel with a sufficiently high decay heat load as determined in accordance with Section 4.5. Calibration of the temperature instruments used to demonstrate heat removal from the HI-TRAC shall be performed in accordance with the requirements for Important to Safety Category B, the remaining components in the system are NITS.
MSLD (Helium Leakage Detector)	Not Important to Safety	Not shown	Used for helium leakage testing of the vent/drain port cover plate welds.
Deleted			
Temporary Shield Ring	Not Important To Safety	8.1.18	A water-filled tank that fits on the cask neutron shield around the upper forging and provides supplemental shielding to personnel performing cask loading and closure operations.
Vacuum Drying (Moisture Removal) System	Not Important To Safety	8.1.22a	Used for removal of residual moisture from the MPC following water draining.
Forced Helium Dehydration System	Important to Safety – Category B	8.1.22b	Used for removal of residual moisture from the MPC following water draining. Calibration of the instrumentation used to confirm Tech Spec compliance shall be performed in accordance with the requirements for Important to Safety Category B, the remaining components of the system are NITS.
Vent and Drain RVOAs	Not Important To Safety	8.1.16	Used to access the vent and drain ports. The vent and drain RVOAs allow the vent and drain ports to be operated like valves and prevent the need to hot tap into the penetrations during unloading operation.
Deleted			
Weld Removal System	Not Important To Safety	8.3.2b	Semi-automated weld removal system used for removal of the MPC field weld to support unloading operations.

[†] Figures are representative and may not depict all configurations for all users.

HOLTEC INTERNATIONAL COPYRIGHTED MATERIAL

Table 8.1.7
 HI-STORM 100 SYSTEM INSTRUMENTATION SUMMARY FOR LOADING AND
 UNLOADING OPERATIONS†

Instrument	Function
Contamination Survey Instruments	Monitors fixed and non-fixed contamination levels.
Dose Rate Monitors/Survey Equipment	Monitors dose rate and contamination levels and ensures proper function of shielding. Ensures assembly debris is not inadvertently removed from the spent fuel pool during overpack removal.
Flow Rate Monitor	Monitors fluid flow rate during various loading and unloading operations.
Helium Mass Spectrometer Leakage Detector (MSLD)	Ensures leakage rates of welds are within acceptable limits.
Deleted	
Deleted	
Volumetric Examination Testing Rig	Used to assess the integrity of the MPC lid-to-shell weld.
Pressure Gauges	Ensures correct pressure during loading and unloading operations.
Temperature Gauges	Monitors the state of gas and water temperatures during closure and unloading operations.
Deleted	
Temperature Surface Pyrometer	For HI-STORM vent operability testing.
Vacuum Gages	Used for vacuum drying operations and to prepare an MPC evacuated sample bottle for MPC gas sampling for unloading operations.
Deleted	
Deleted	
Moisture Monitoring Instruments	Used to monitor the MPC moisture levels as part of the moisture removal system.

† All instruments require calibration. See figures at the end of this section for additional instruments, controllers and piping diagrams.

Table 8.1.8
HI-STORM 100 SYSTEM OVERPACK INSPECTION CHECKLIST

Note:

This checklist provides the basis for establishing a site-specific inspection checklist for the HI-STORM 100 overpack. Specific findings shall be brought to the attention of the appropriate site organizations for assessment, evaluation and potential corrective action prior to use.

HI-STORM 100 Overpack Lid:

1. Lid studs and nuts or lid closure bolts shall be inspected for general condition.
2. The painted surfaces shall be inspected for corrosion and chipped, cracked or blistered paint.
3. All lid surfaces shall be relatively free of dents, scratches, gouges or other damage.
4. The lid shall be inspected for the presence or availability of studs and nuts and hole plugs.
5. Lid lifting device/ holes shall be inspected for dirt and debris and thread condition.
6. Lid bolt holes shall be inspected for general condition.

HI-STORM 100 Main Body:

1. Lid bolt holes shall be inspected for dirt, debris, and thread condition.
2. Vents shall be free from obstructions.
3. Vent screens shall be available, intact, and free of holes and tears in the fabric.
4. The interior cavity shall be free of debris, litter, tools, and equipment.
5. Painted surfaces shall be inspected for corrosion, and chipped, cracked or blistered paint.
6. The nameplate shall be inspected for presence, legibility, and general condition and conformance to Quality Assurance records package.
7. Anchor hardware, if used, shall be checked for general condition.

HOLTEC INTERNATIONAL COPYRIGHTED MATERIAL

HI-STORM FSAR
REPORT HI-2002444

8.1-42

Rev. 12

Table 8.1.9
MPC INSPECTION CHECKLIST

Note:

This checklist provides the basis for establishing a site-specific inspection checklist for MPC. Specific findings shall be brought to the attention of the appropriate site organizations for assessment, evaluation and potential corrective action prior to use.

MPC Lid and Closure Ring:

1. The MPC lid and closure ring surfaces shall be relatively free of dents, gouges or other shipping damage.
2. The drain line shall be inspected for straightness, thread condition, and blockage.
3. Vent and Drain attachments shall be inspected for availability, thread condition operability and general condition.
4. Upper fuel spacers (if used) shall be inspected for availability and general condition. Plugs shall be available for non-used spacer locations.
5. Lower fuel spacers (if used) shall be inspected for availability and general condition.
6. Drain and vent port cover plates shall be inspected for availability and general condition.
7. Serial numbers shall be inspected for readability.
8. The MPC lid lift holes shall be inspected for thread condition.

MPC Main Body:

1. All visible MPC body surfaces shall be inspected for dents, gouges or other shipping damage.
2. Fuel cell openings shall be inspected for debris, dents and general condition.
3. Lift lugs shall be inspected for general condition.
4. Verify proper MPC basket type for contents.

Table 8.1.10
HI-TRAC TRANSFER CASK INSPECTION CHECKLIST

Note:

This checklist provides the basis for establishing a site-specific inspection checklist for the HI-TRAC Transfer Cask. Specific findings shall be brought to the attention of the appropriate site organizations for assessment, evaluation and potential corrective action prior to use.

HI-TRAC Top Lid:

1. The painted surfaces shall be inspected for corrosion and chipped, cracked or blistered paint.
2. All Top Lid surfaces shall be relatively free of dents, scratches, gouges or other damage.

HI-TRAC Main Body:

1. The painted surfaces shall be inspected for corrosion, chipped, cracked or blistered paint.
2. The Top Lid bolt holes shall be inspected for dirt, debris and thread damage.
3. The Top Lid lift holes shall be inspected for thread condition.
4. Lifting trunnions shall be inspected for deformation, cracks, damage, corrosion, excessive galling, and, if applicable, damage to the locking plate and end plate, and presence or availability of locking plate and end plate retention bolts.
5. Pocket trunnion, if used, recesses shall be inspected for indications of overstressing (i.e., cracks, deformation, and excessive wear).
6. Annulus inflatable seal groove shall be inspected for cleanliness, scratches, dents, gouges, sharp corners, burrs or any other condition that may damage the inflatable seal.
7. The nameplate shall be inspected for presence and general condition.
8. The neutron shield jacket shall be inspected for leaks.
9. Neutron shield jacket pressure relief valve shall be inspected for presence, and general condition.
10. The neutron shield jacket fill and drain plugs shall be inspected for presence, leaks, and general condition.
11. Bottom lid flange surface shall be clean and free of large scratches and gouges.

HOLTEC INTERNATIONAL COPYRIGHTED MATERIAL

HI-STORM FSAR
REPORT HI-2002444

8.1-44

Rev. 12

HI-STORM 100 FSAR, NON-PROPRIETARY
REVISION 12
MARCH 12, 2014

Table 8.1.10 (Continued)
HI-TRAC OVERPACK INSPECTION CHECKLIST

HI-TRAC Transfer Lid (Not used with HI-TRAC 100D and 125D):

1. The doors shall be inspected for smooth actuation.
2. The threads shall be inspected for general condition.
3. The bolts shall be inspected for indications of overstressing (i.e., cracks, deformation, thread damage, excessive wear) and replaced as necessary.
4. Door locking pins shall be inspected for indications of overstressing (i.e., cracks, and deformation, thread damage, excessive wear) and replaced as necessary.
5. Painted surfaces shall be inspected for corrosion and chipped, cracked or blistered paint.
6. Lifting holes shall be inspected for thread damage.

HI-TRAC Pool Lid:

1. Seal shall be inspected for cracks, breaks, cuts, excessive wear, flattening, and general condition.
2. Drain line shall be inspected for blockage and thread condition.
3. The lifting holes shall be inspected for thread damage.
4. The bolts shall be inspected for indications of overstressing (i.e., cracks and deformation, thread damage, and excessive wear).
5. Painted surfaces shall be inspected for corrosion and chipped, cracked or blistered paint.
6. Threads shall be inspected for indications of damage.

LOCATION: CASK RECEIVING AREA
REMOVE HI-TRAC TOP LID
CONFIGURE HI-TRAC WITH POOL LID
INSTALL MPC IN HI-TRAC
INSTALL UPPER FUEL SPACERS
INSTALL LOWER FUEL SPACERS
FILL MPC AND ANNULUS
INSTALL ANNULUS SEAL
PLACE HI-TRAC IN SPENT FUEL POOL
LOCATION: SPENT FUEL POOL
LOAD FUEL ASSEMBLIES INTO MPC
PERFORM ASSEMBLY IDENTIFICATION VERIFICATION
INSTALL DRAIN LINE TO MPC LID
ALIGN MPC LID AND LIFT YOKE TO DRAIN LINE
INSTALL MPC LID
REMOVE HI-TRAC FROM SPENT FUEL POOL AND PLACE IN PREPARATION AREA
LOCATION: CASK PREPARATION AREA
DECONTAMINATE HI-TRAC BOTTOM
SET HI-TRAC IN CASK PREPARATION AREA
FILL NEUTRON WATER JACKET
MEASURE DOSE RATES AT MPC LID
DECONTAMINATE HI-TRAC AND LIFT YOKE
INSTALL TEMPORARY SHIELD RING
REMOVE INFLATABLE ANNULUS SEAL
LOWER ANNULUS WATER LEVEL SLIGHTLY
SMEAR MPC LID TOP SURFACES
INSTALL ANNULUS SHIELD
LOWER MPC WATER LEVEL
WELD MPC LID & PERFORM NDE
DELETED
RAISE MPC WATER LEVEL
PERFORM MPC LID-TO-SHELL WELD PRESSURE TEST
DELETED
DRAIN MPC
MEASURE VOLUME OF WATER DRAINED
DRY MPC
PERFORM MPC DRYNESS VERIFICATION TEST

BACKFILL MPC
WELD VENT AND DRAIN PORT COVER PLATES & PERFORM NDE
PERFORM LEAKAGE TEST ON CLOSURE PLATES
WELD MPC CLOSURE RING & PERFORM NDE
DRAIN ANNULUS
INSTALL HI-TRAC TOP LID
PERFORM SURVEYS ON HI-TRAC
REMOVE TEMPORARY SHIELD RING
REPLACE POOL LID WITH TRANSFER LID (Not Required for HI-TRAC 100D and 125D)
INSTALL MPC LIFT CLEAT
PERFORM SURVEYS OF POOL LID
PERFORM HI-TRAC SURFACE DOSE RATE MEASUREMENTS (PER TS)
LOCATION: CASK RECEIVING AREA
POSITION HI-STORM FOR MPC TRANSFER
INSTALL ALIGNMENT DEVICE (MATING DEVICE FOR HI-TRAC 100D and 125D) & VENT DUCT SHIELD INSERTS
MATE OVERPACK AND TRANSFER CASK
ATTACH MPC SLINGS
OPEN TRANSFER LID DOORS (Remove pool lid and open mating device drawer for HI-TRAC 100D and 125D)
LOWER MPC INTO HI-STORM
REMOVE HI-TRAC FROM ON TOP OF HI-STORM
REMOVE MPC LIFT CLEAT
REMOVE ALIGNMENT DEVICE (Mating device for HI-TRAC 100D and 125D) & VENT DUCT SHIELD INSERTS
INSTALL HI-STORM LID
PERFORM HI-STORM SURFACE DOSE RATE MEASUREMENTS (PER TS)
LOCATION: ISFSI
PLACE HI-STORM IN STORAGE
INSTALL GAMMA SHIELD CROSS PLATES AND THERMOCOUPLES IN HI-STORM 100 OVERPACK EXIT VENTS
INSTALL HI-STORM VENT SCREENS
PERFORM THERMAL TESTING

Figure 8.1.1; Loading Operations Flow Diagram

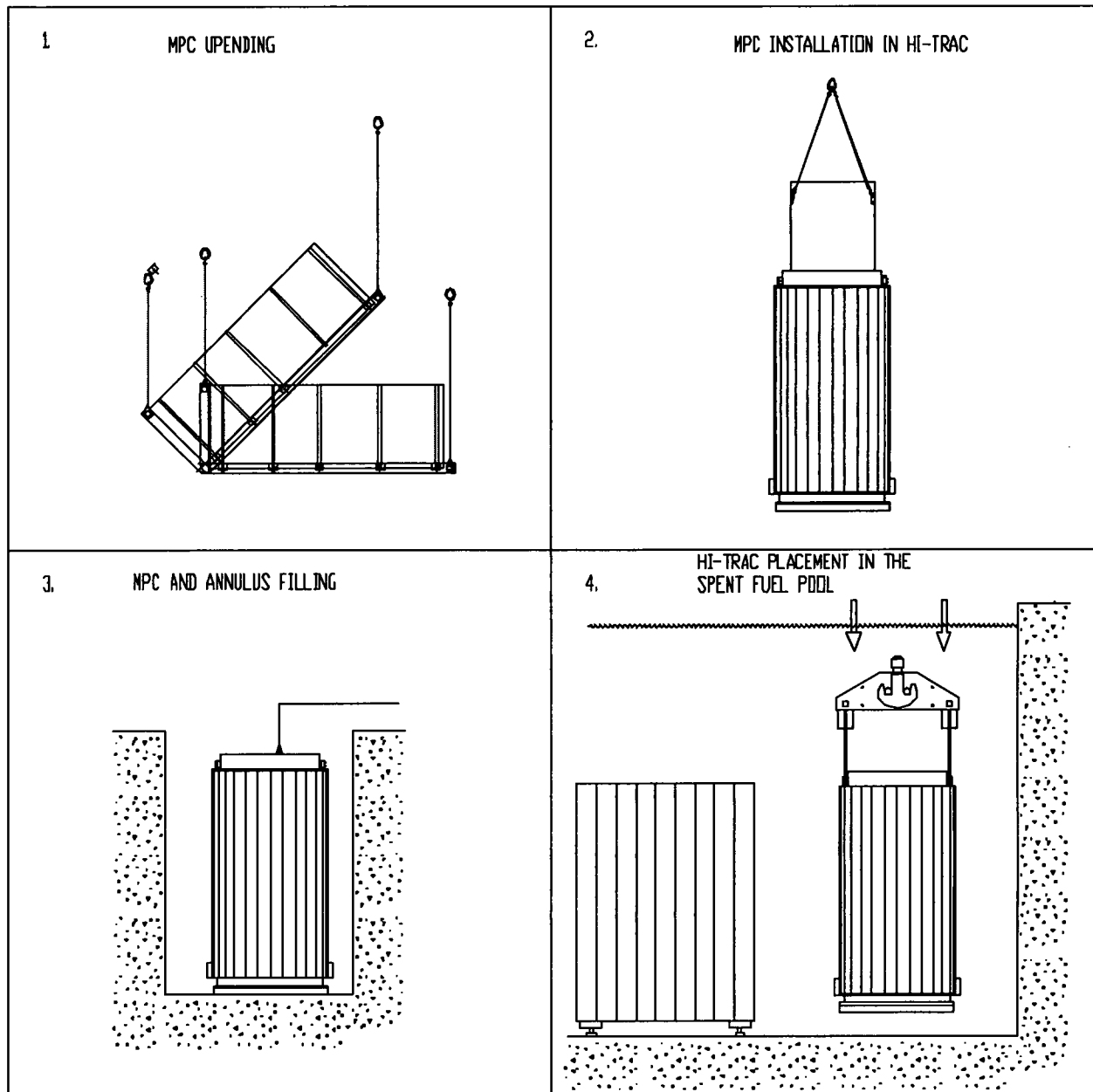


Figure 8.1.2a; Major HI-STORM 100 Loading Operations

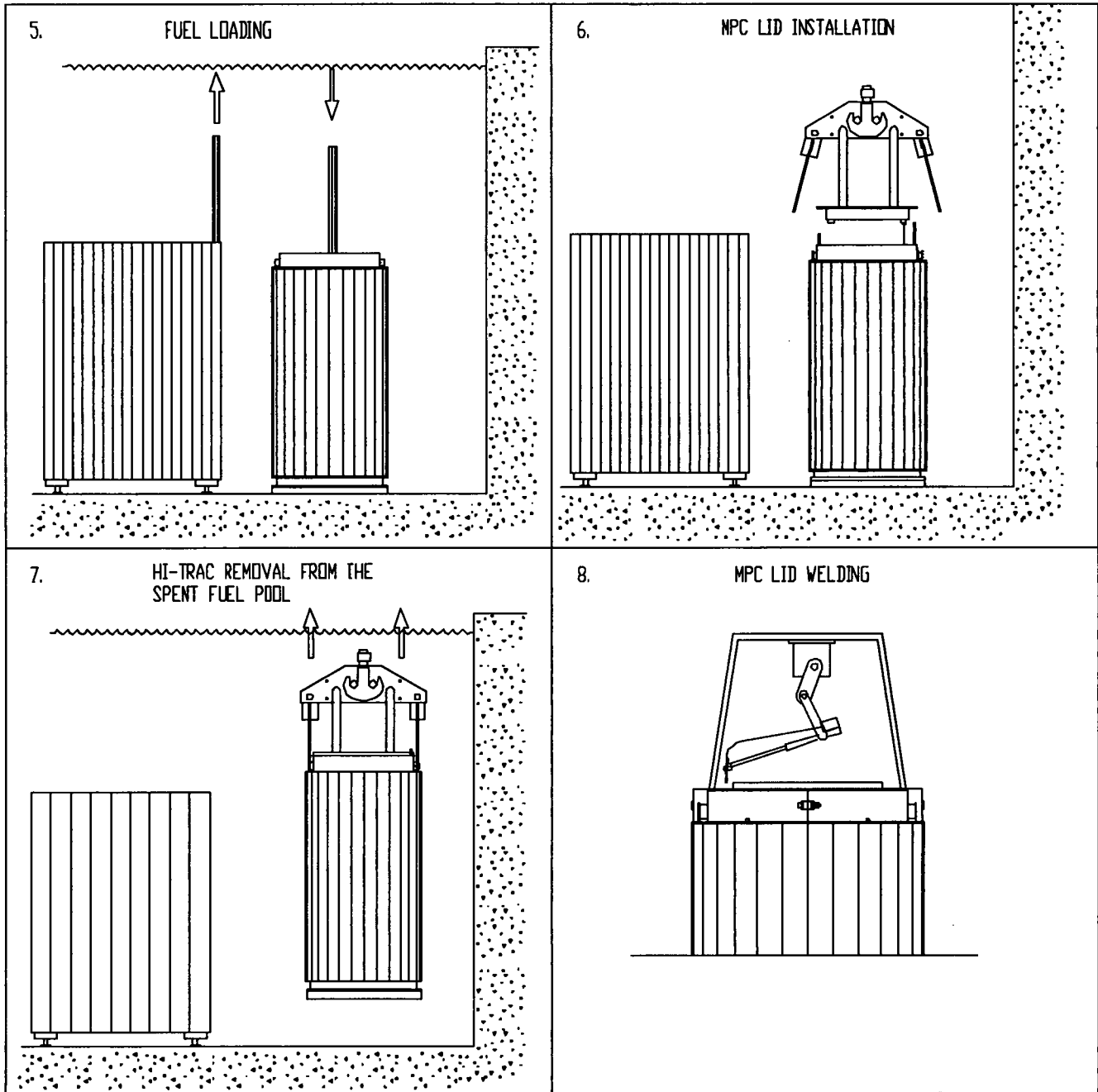
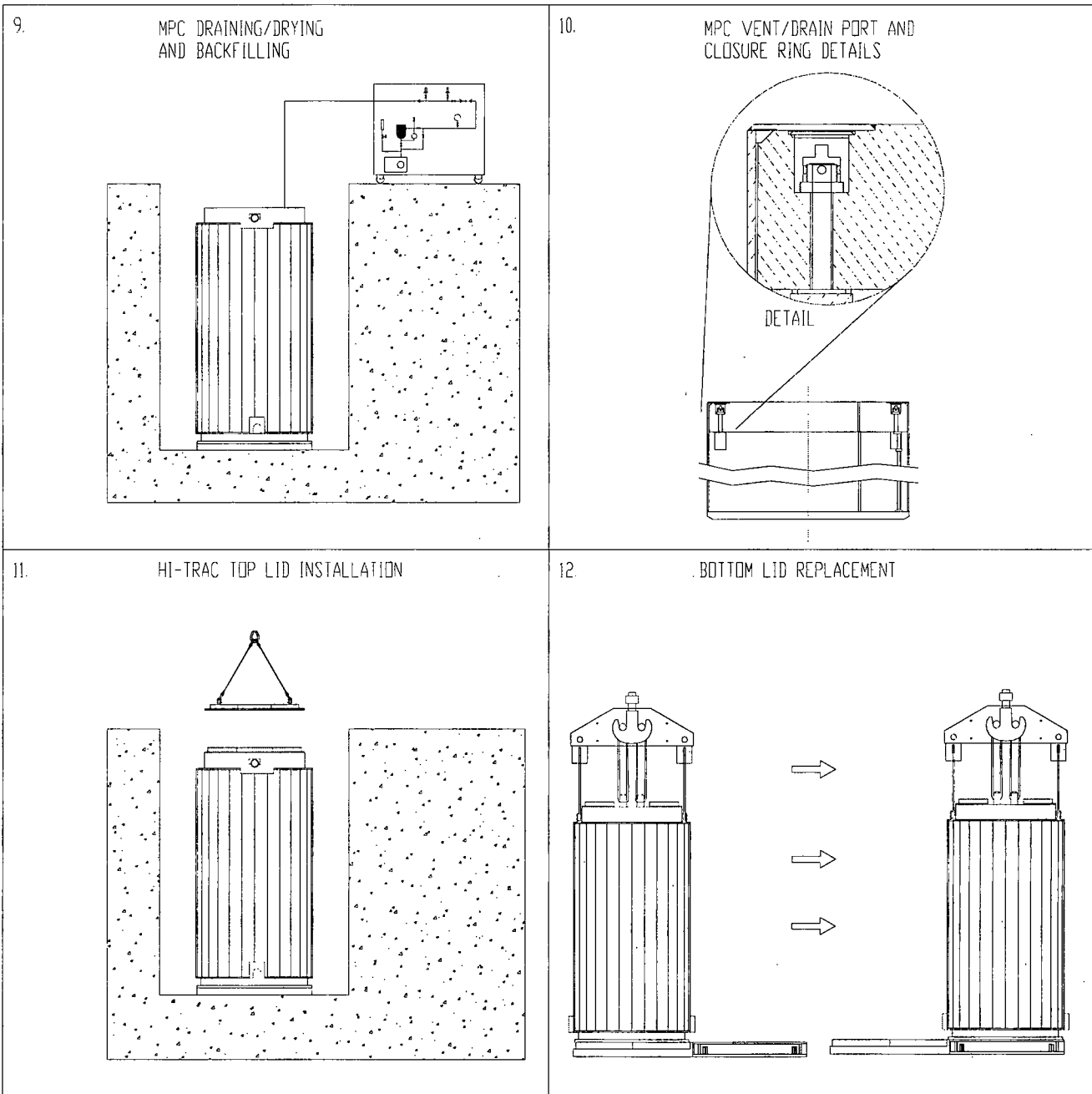


Figure 8.1.2b; Major HI-STORM 100 Loading Operations



Note: Bottom Lid Replacement is not required for HI-TRAC 100D and 125D

Figure 8.1.2c; Major HI-STORM 100 Loading Operations

13.

SAMPLE MPC TRANSFER MODES

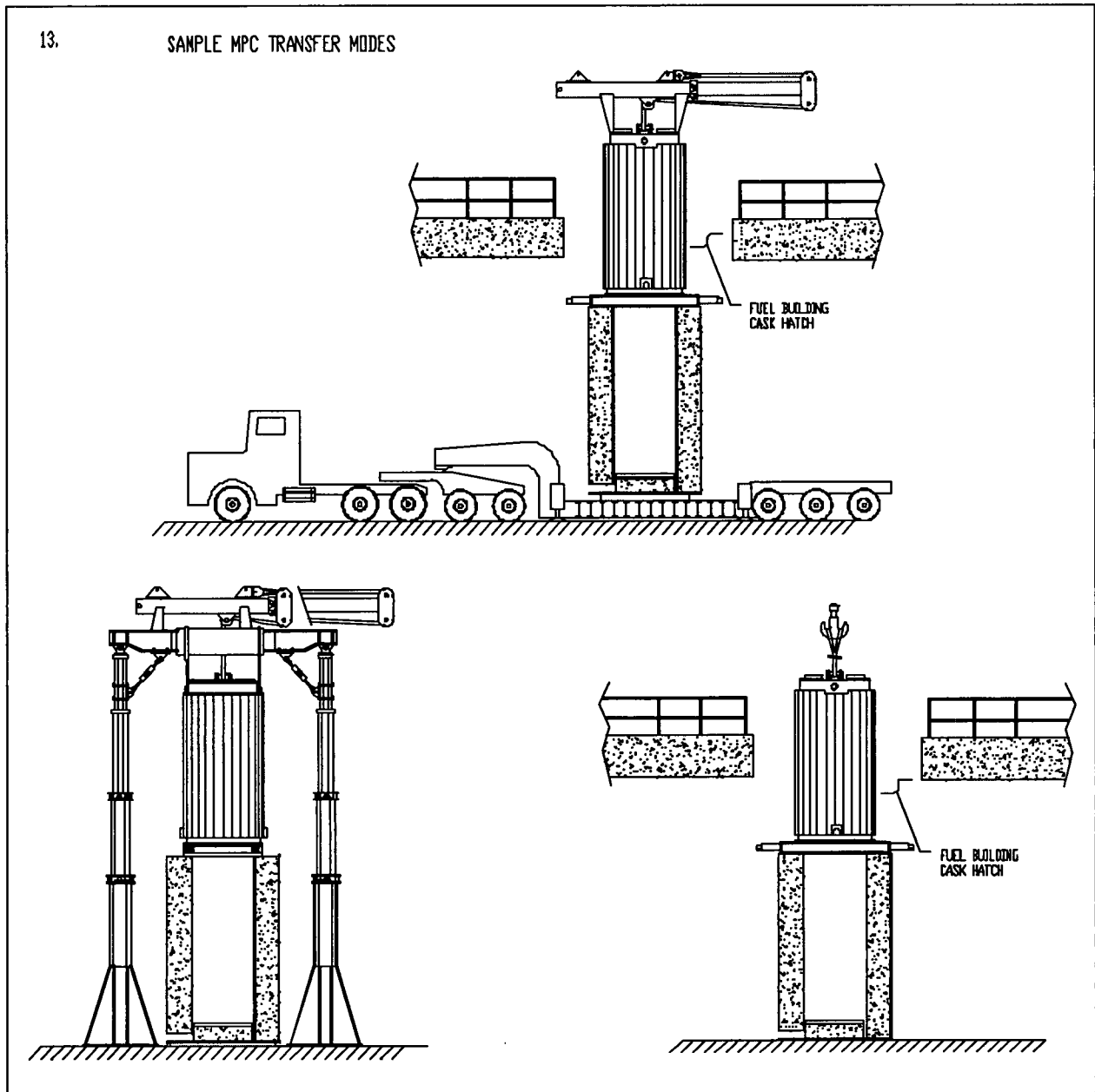
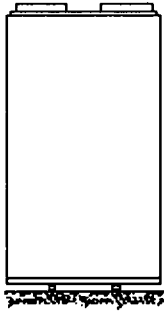


Figure 8.1.2d; Major HI-STORM 100 Loading Operations(HI-TRAC with Transfer Lid Shown)

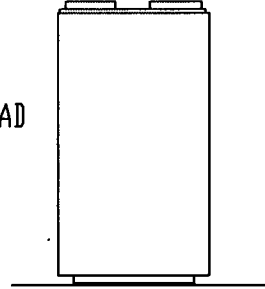
14.

SAMPLE HI-STORM HANDLING METHODS

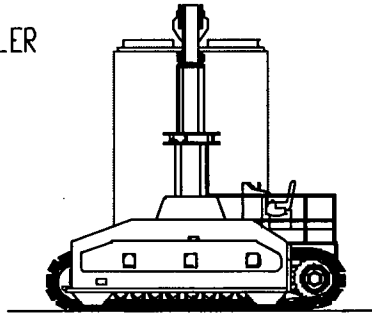
RAIL DOLLY



AIR PAD



CASK CRAWLER



HEAVY-HAUL TRAILER

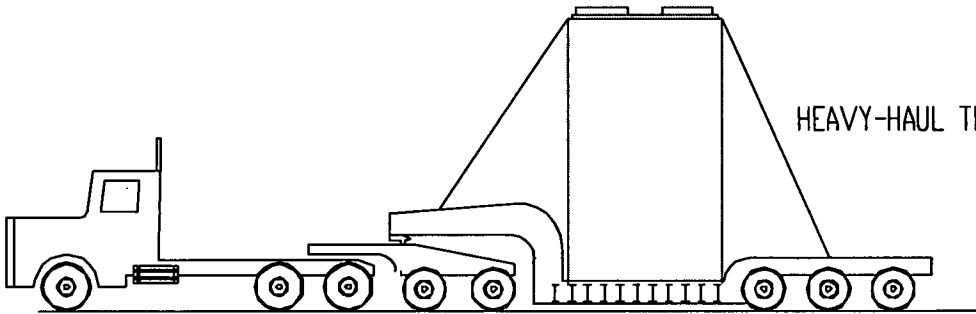


Figure 8.1.2e; Example of HI-STORM 100 Handling Options

15.

SAMPLE HI-TRAC HANDLING METHODS

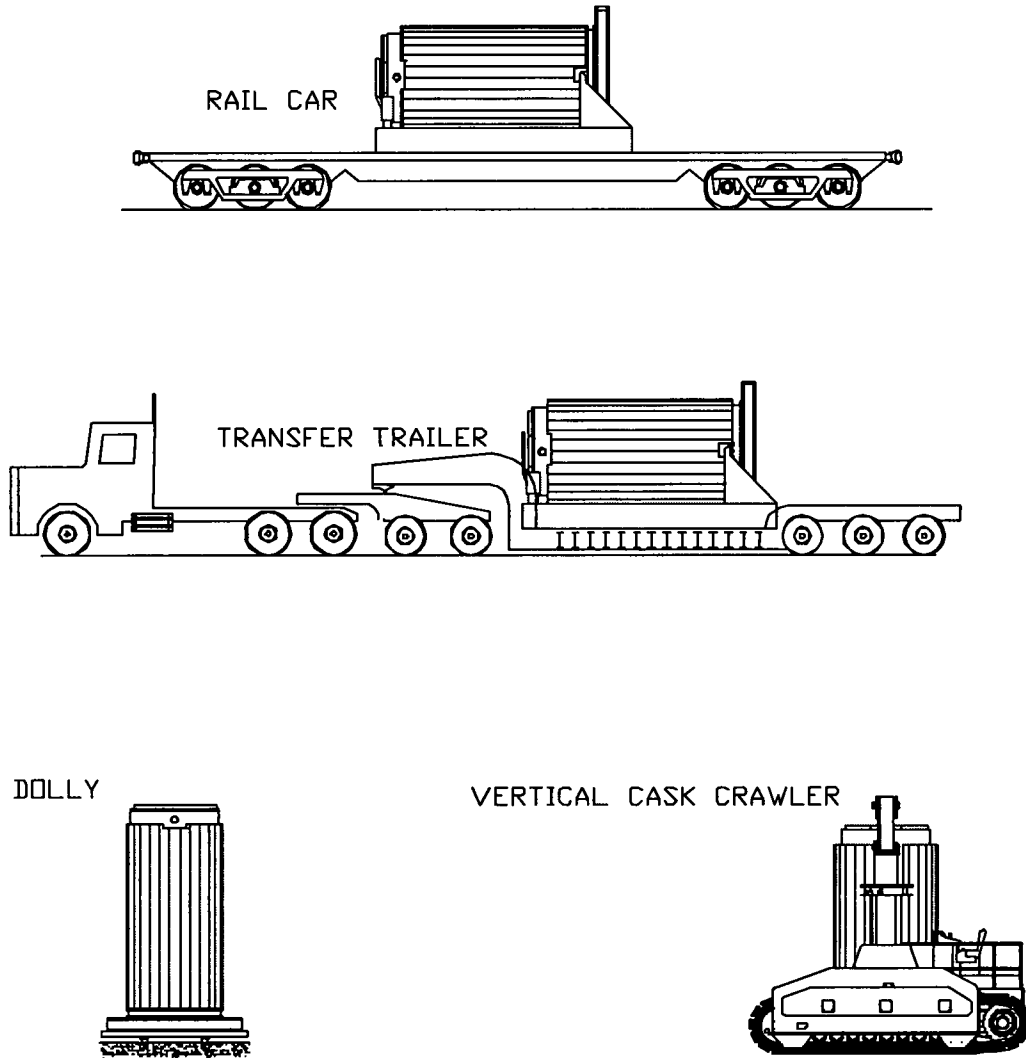
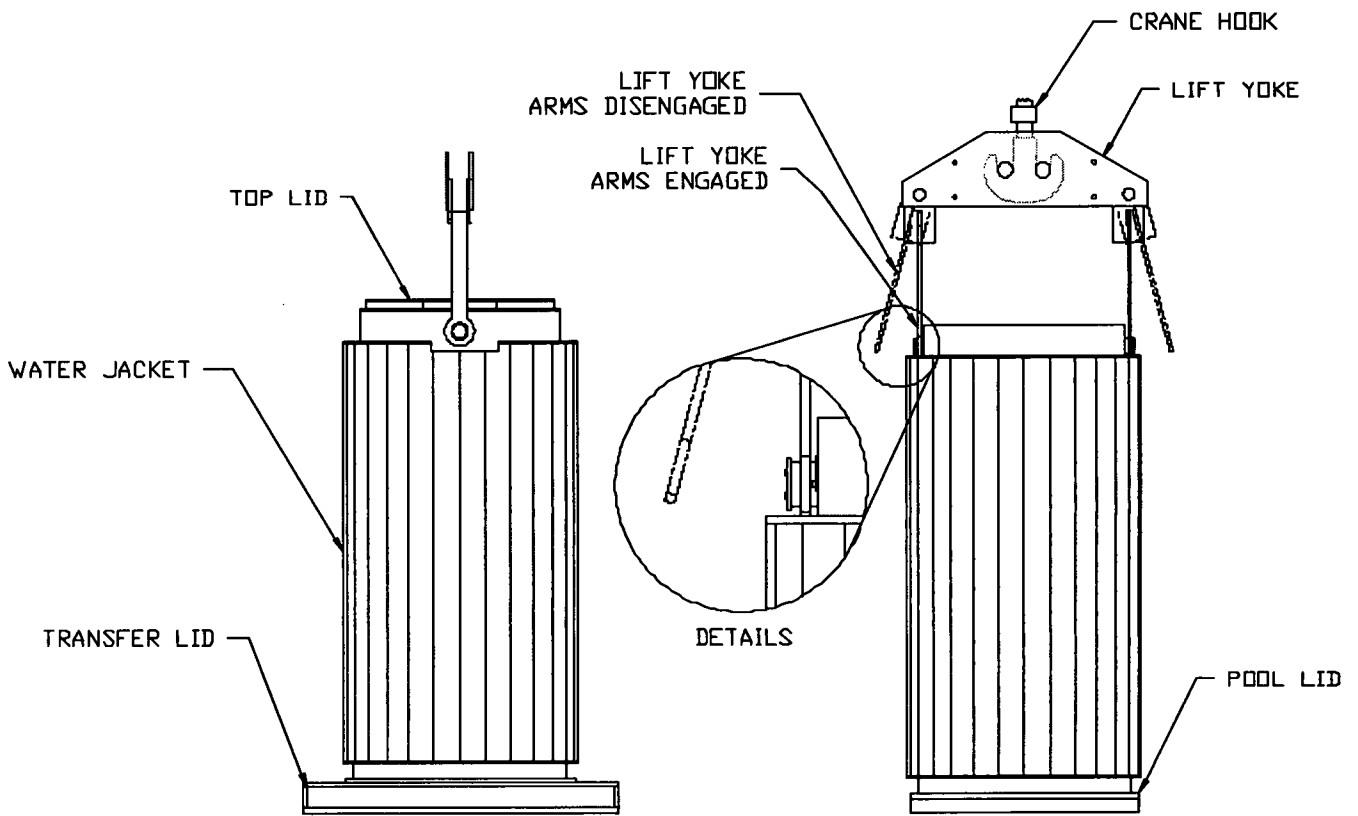
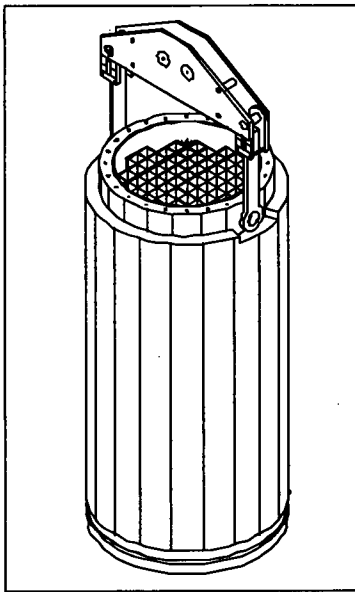


Figure 8.1.2f; Example of HI-TRAC Handling Options (Missile Shields Not Shown For Clarity)



**Figure 8.1.3; Lift Yoke Engagement and Vertical HI-TRAC Handling
(Shown with the Pool Lid and the Transfer Lid)**

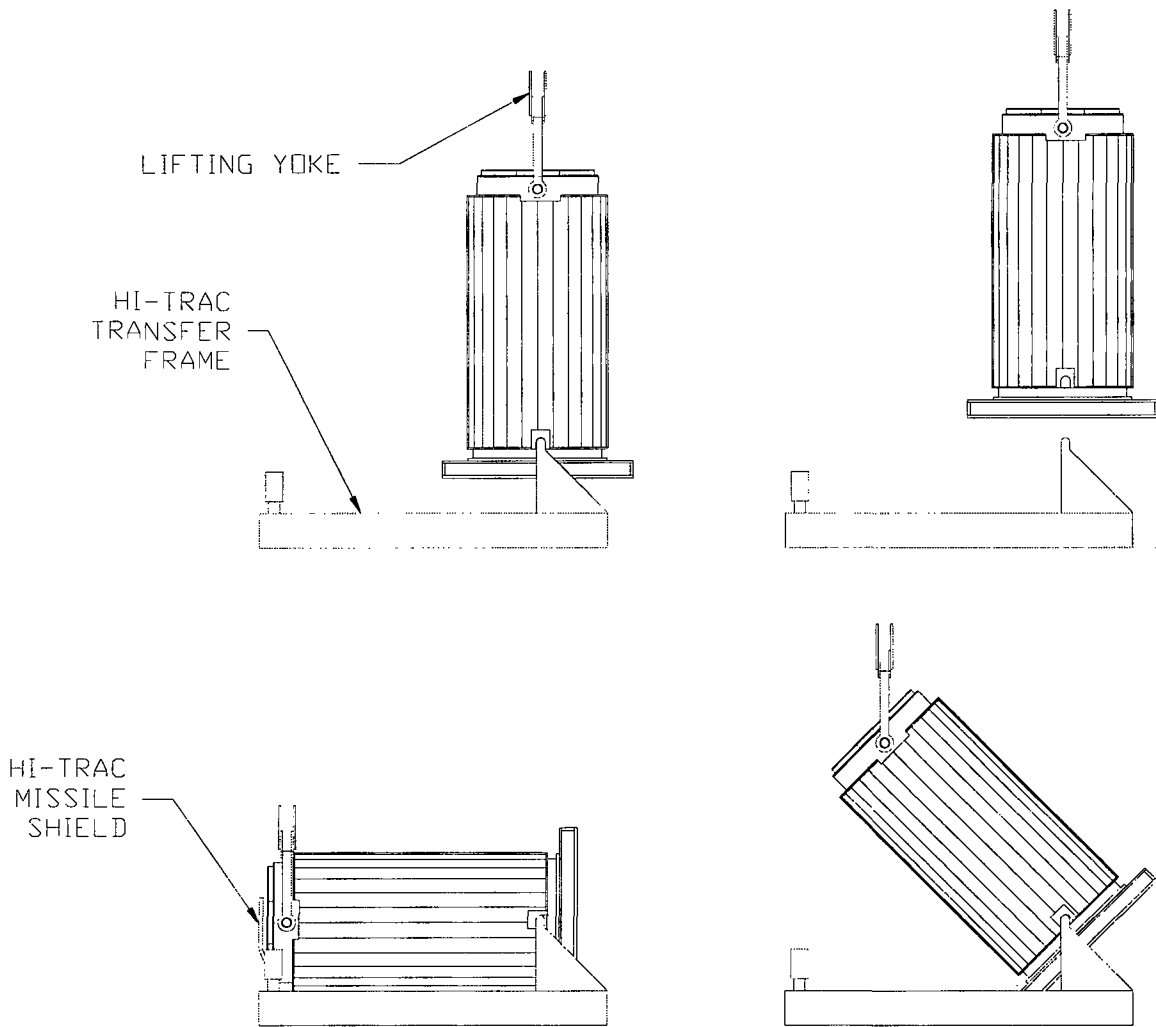
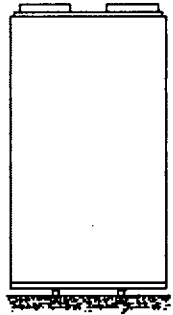


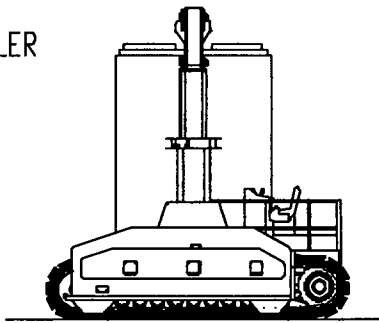
Figure 8.1.4; HI-TRAC Upending/Downending in the Transfer Frame

(HI-TRAC with pocket trunnions shown, HI-TRAC 100D and 125D utilize separate upending frame without pocket trunnions)

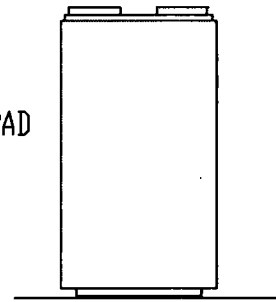
RAIL DOLLY



CASK CRAWLER



AIR PAD



HEAVY-HAUL TRAILER

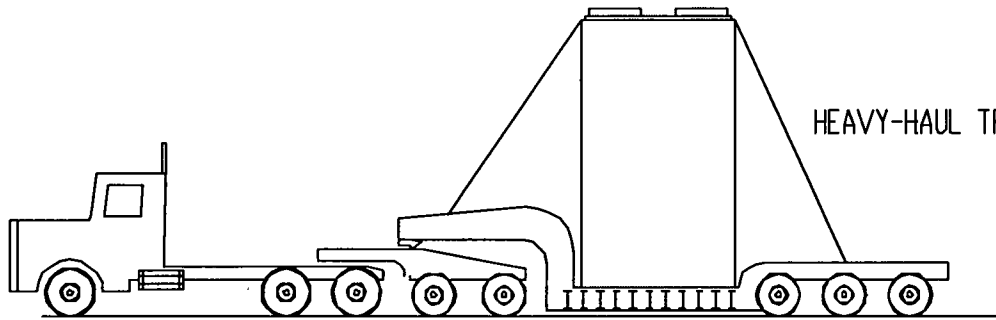


Figure 8.1.5; HI-STORM Vertical Handling

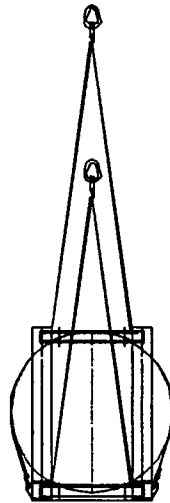
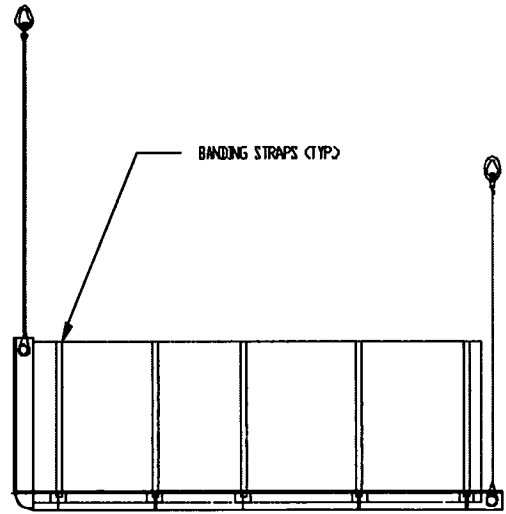
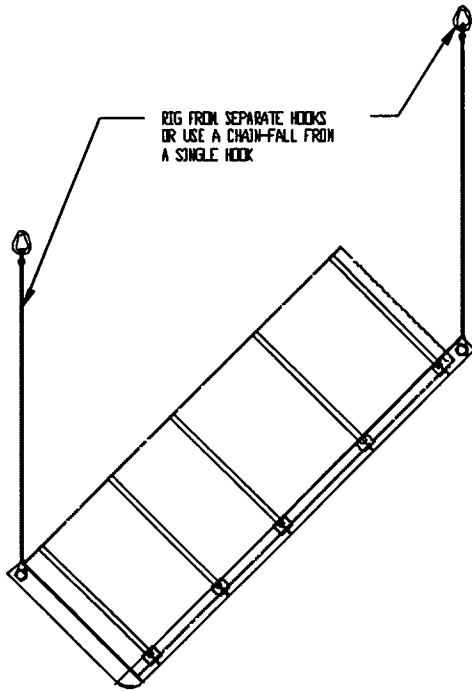
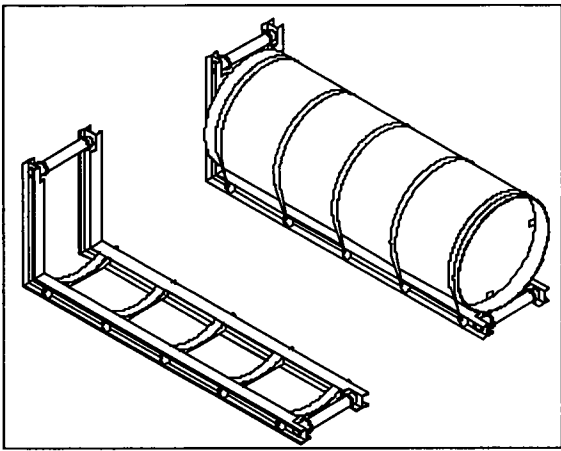


Figure 8.1.6; MPC Upending in the MPC Upending Frame

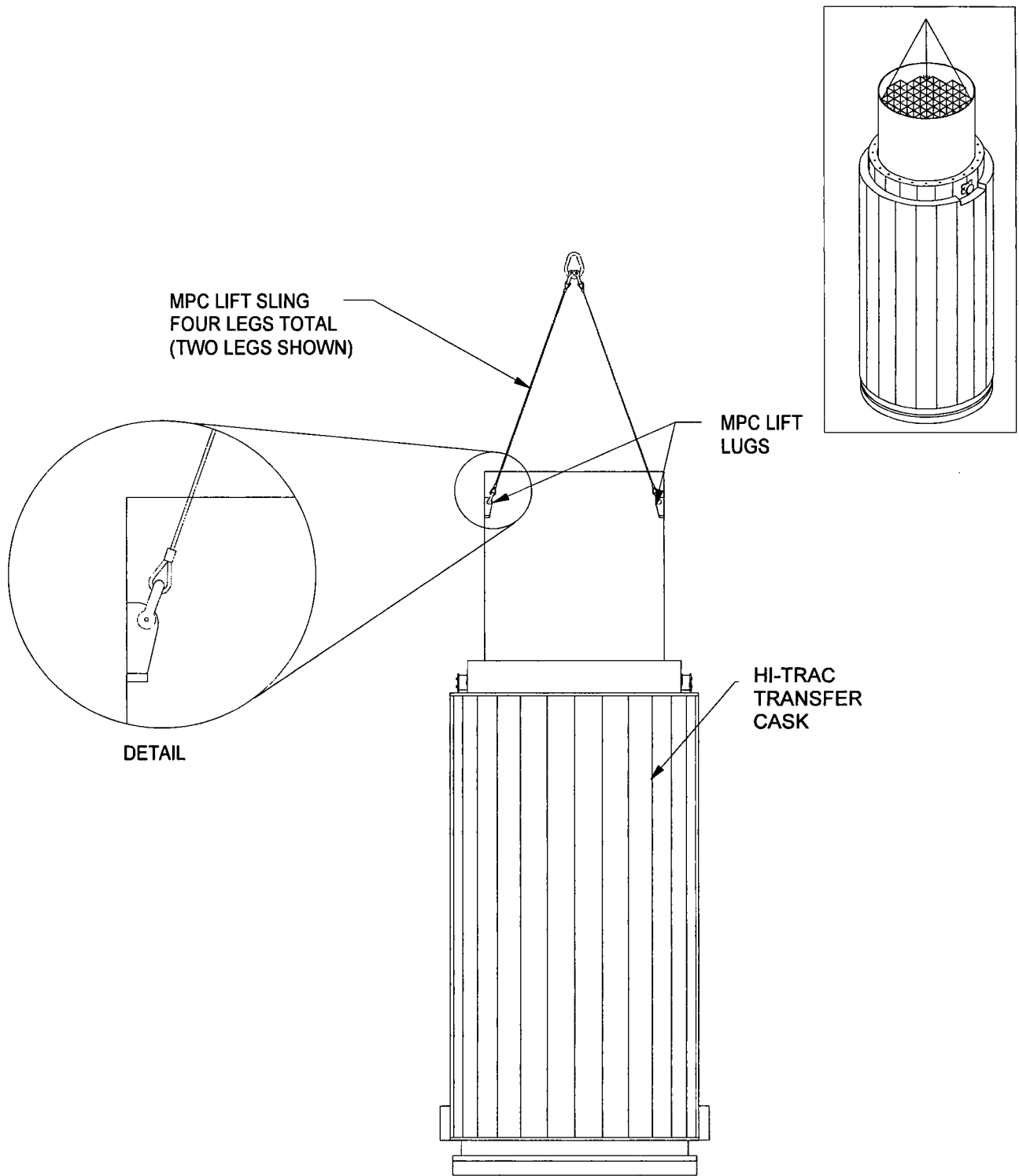


Figure 8.1.7; MPC Rigging for Vertical Lifts

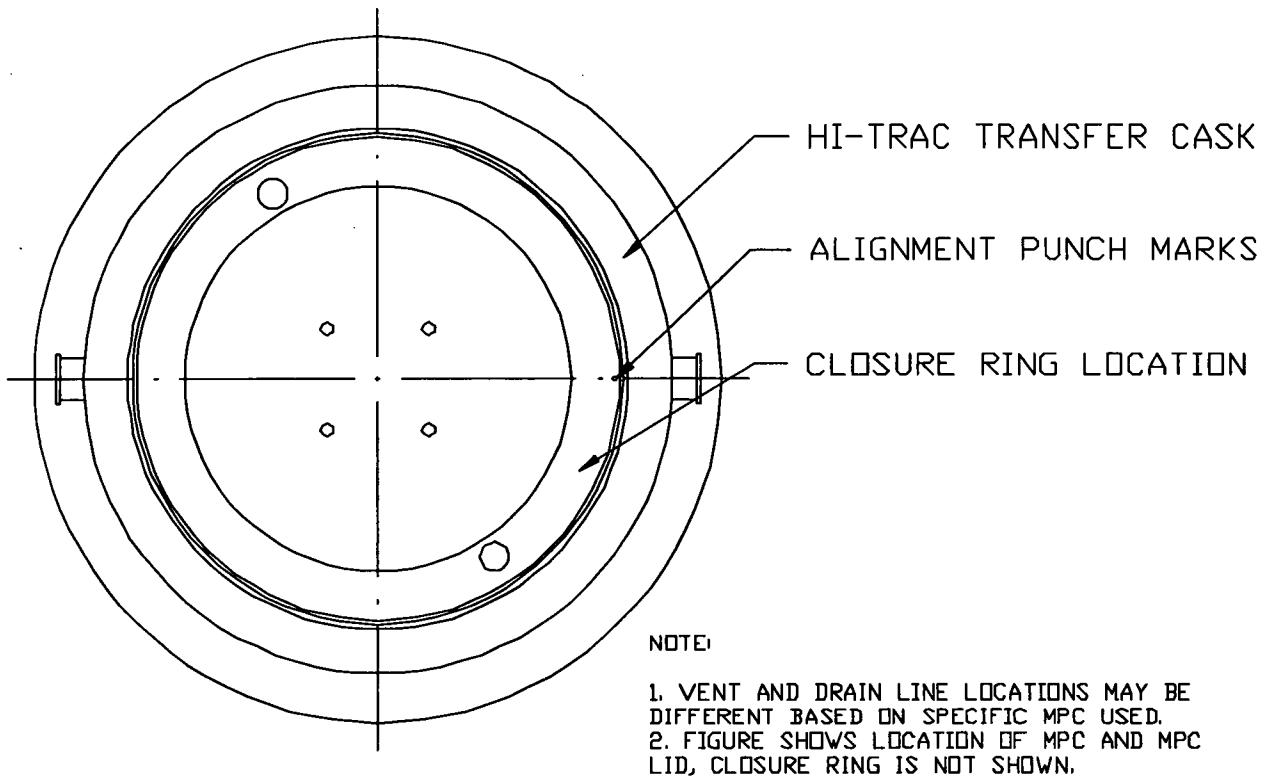


Figure 8.1.8; MPC Alignment in HI-TRAC

RIGGING FOR HI-TRAC TOP LID,
POOL LID, TRANSFER STEP AND
AWS BASEPLATE (SHOWN WITH
HI-TRAC TOP LID)

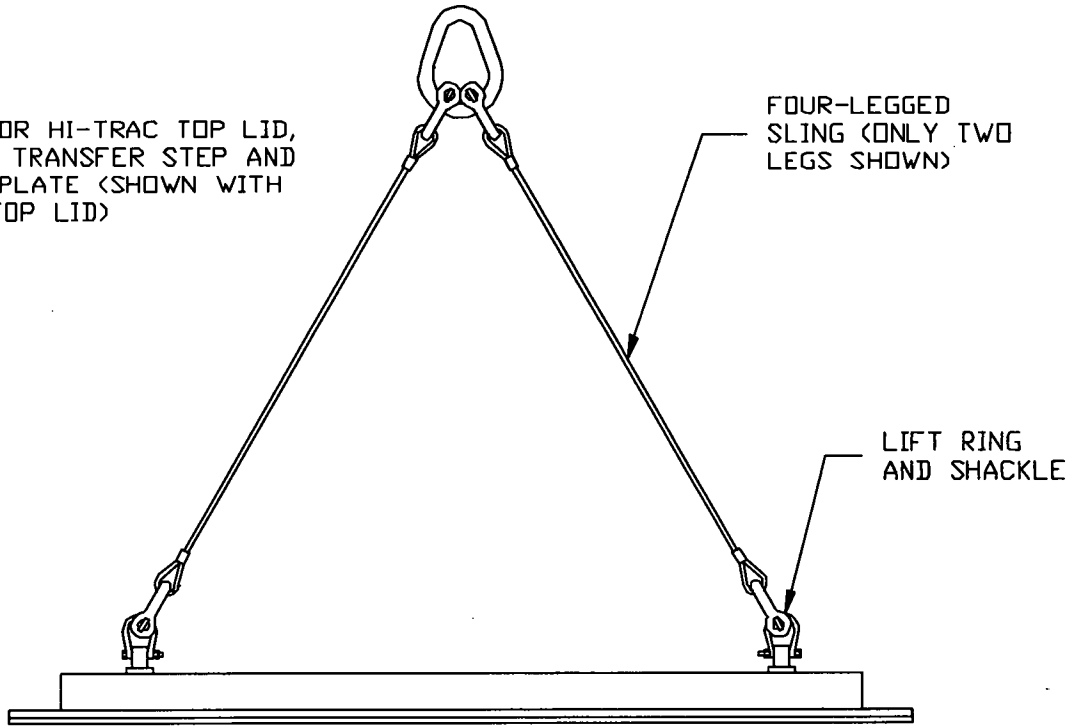
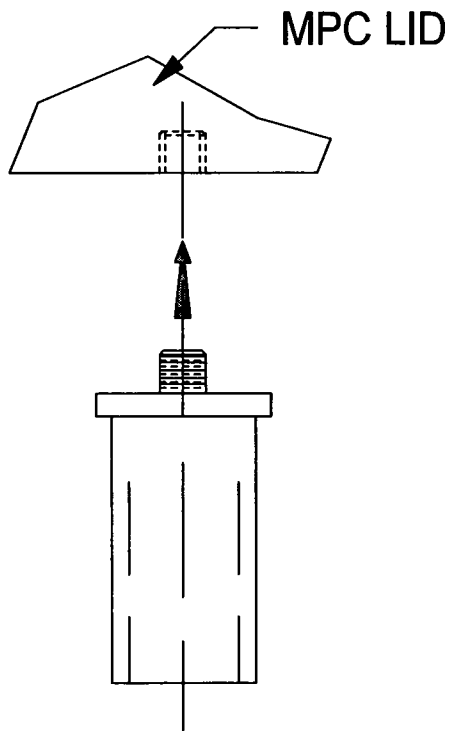
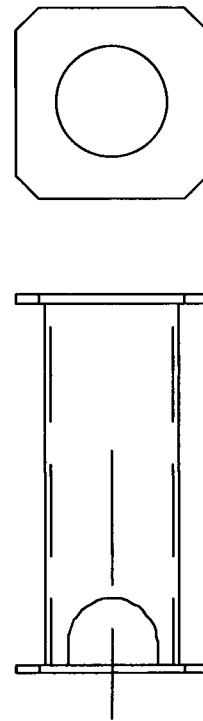


Figure 8.1.9; MPC Lid AND HI-TRAC Accessory Rigging



UPPER FUEL SPACER



LOWER FUEL SPACER

Note: Lengths are based on specific fuel assembly type to be stored.

Figure 8.1.10; Fuel Spacers

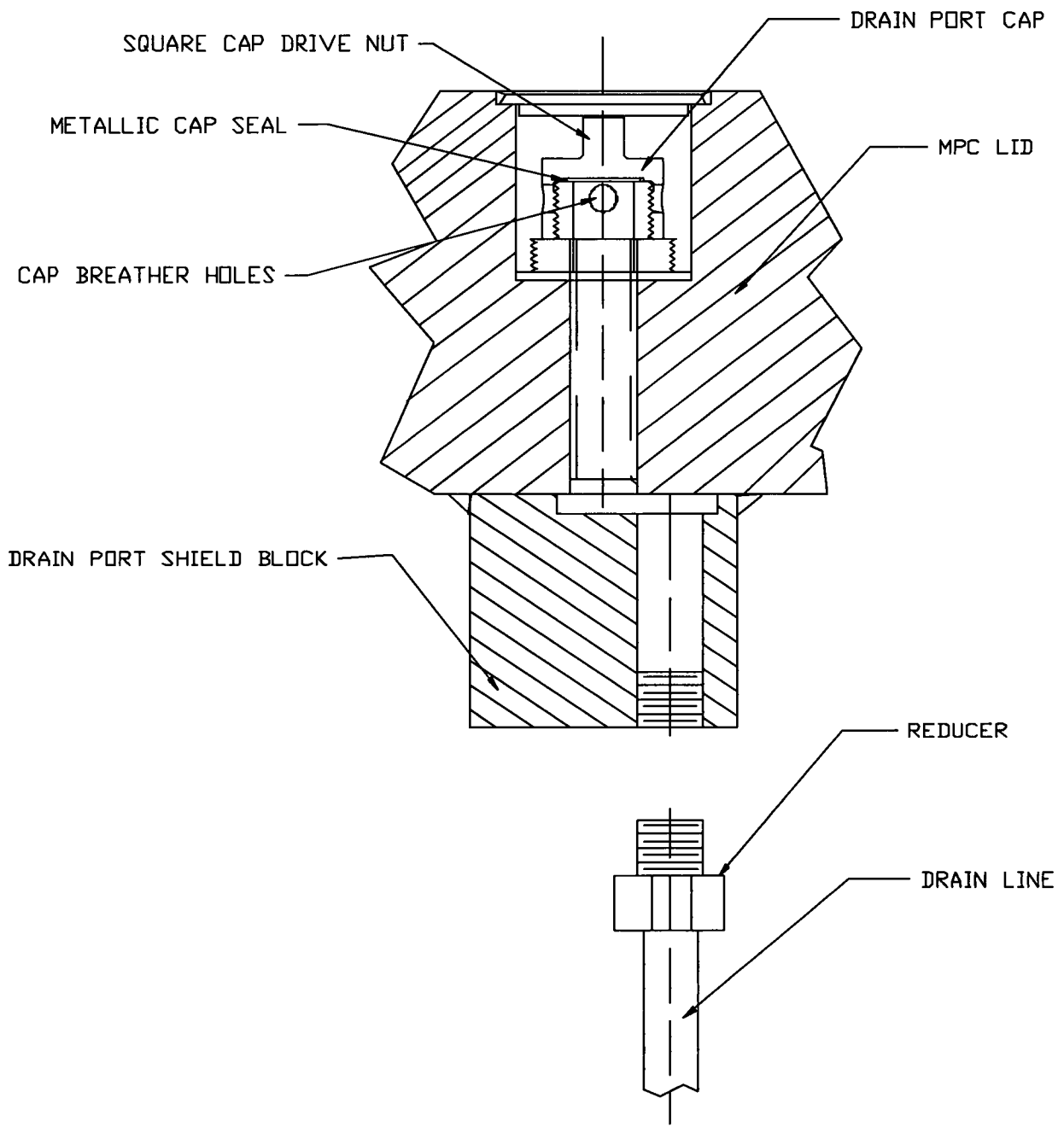


Figure 8.1.11; Drain Port Details

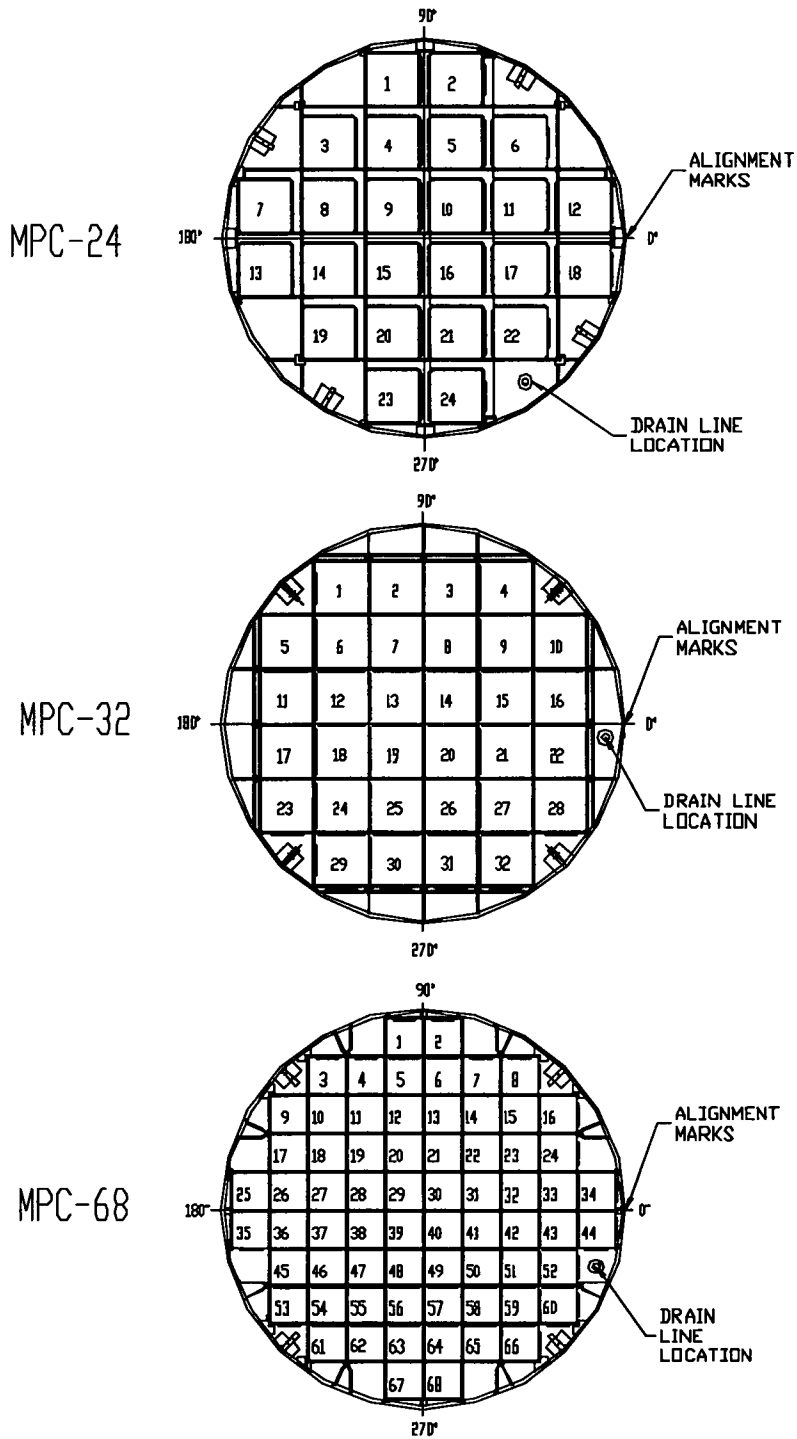


Figure 8.1.12; Drain Line Positioning

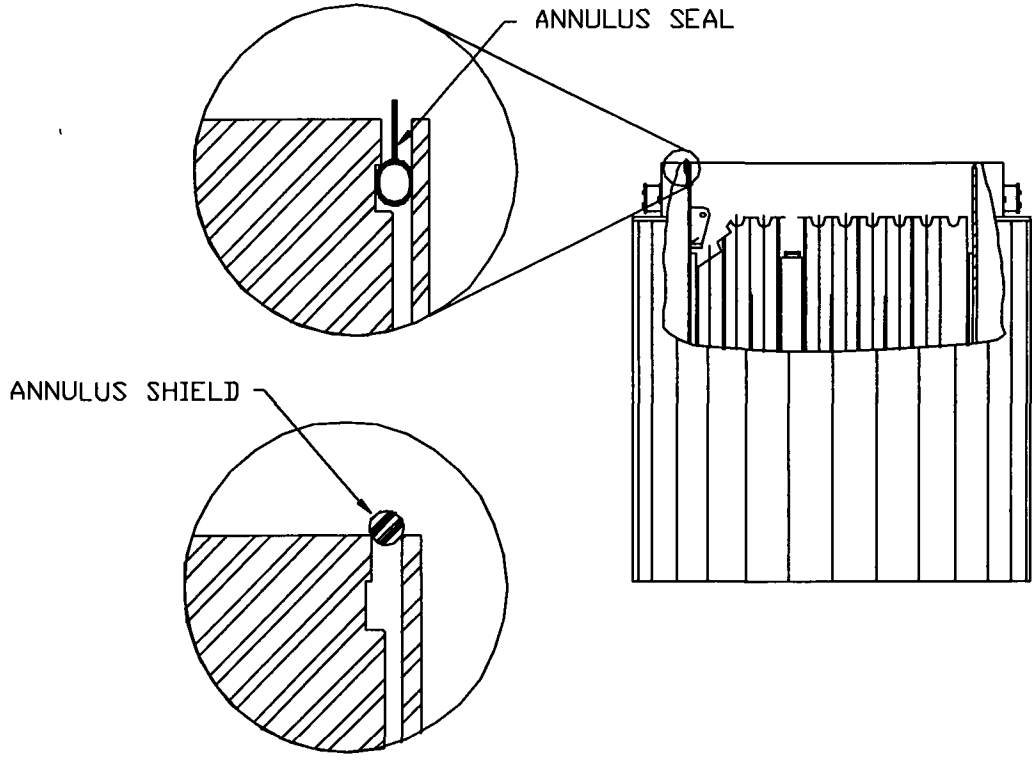


Figure 8.1.13; Annulus Shield/Annulus Seal

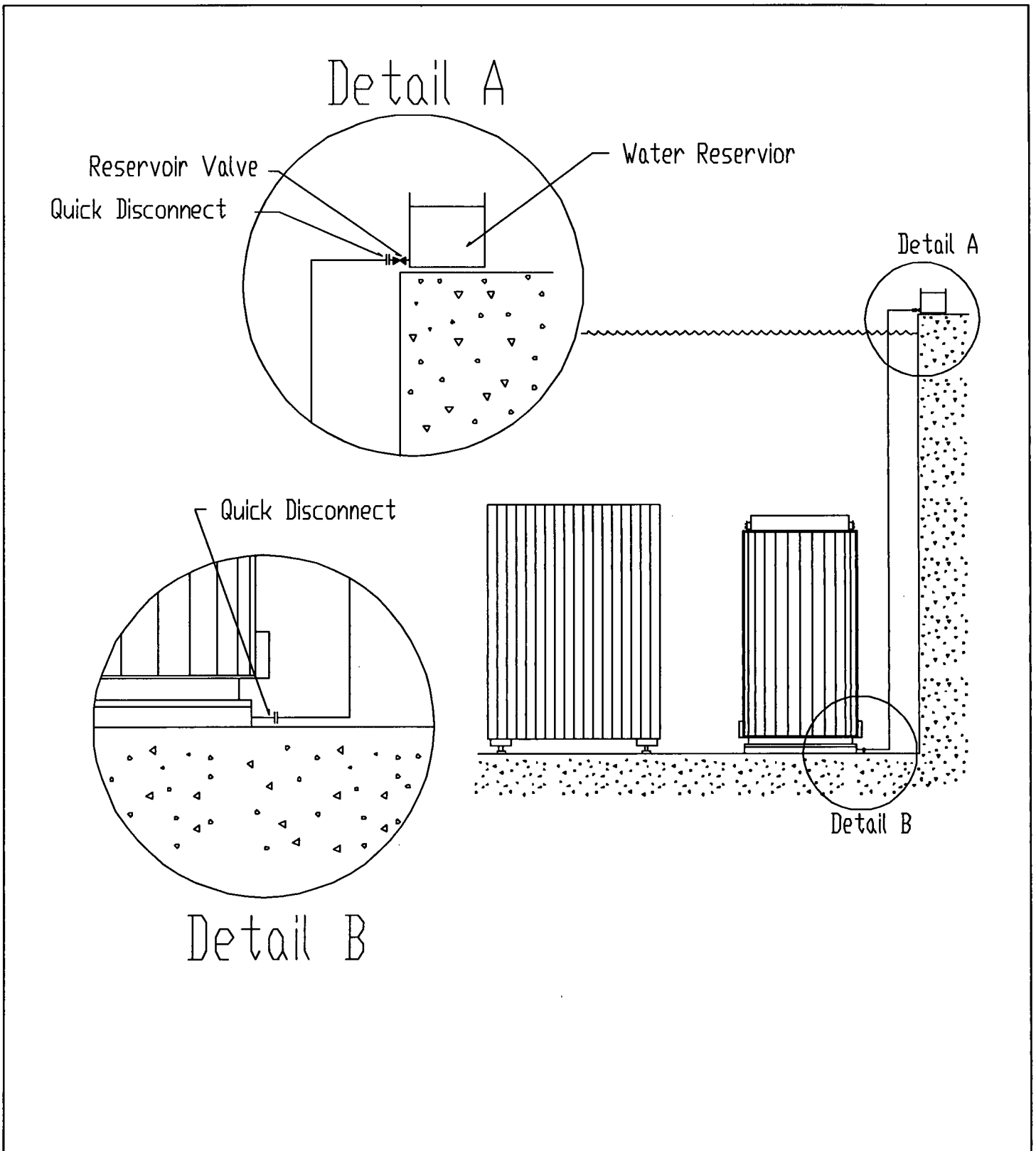


Figure 8.1.14; Annulus Overpressure System

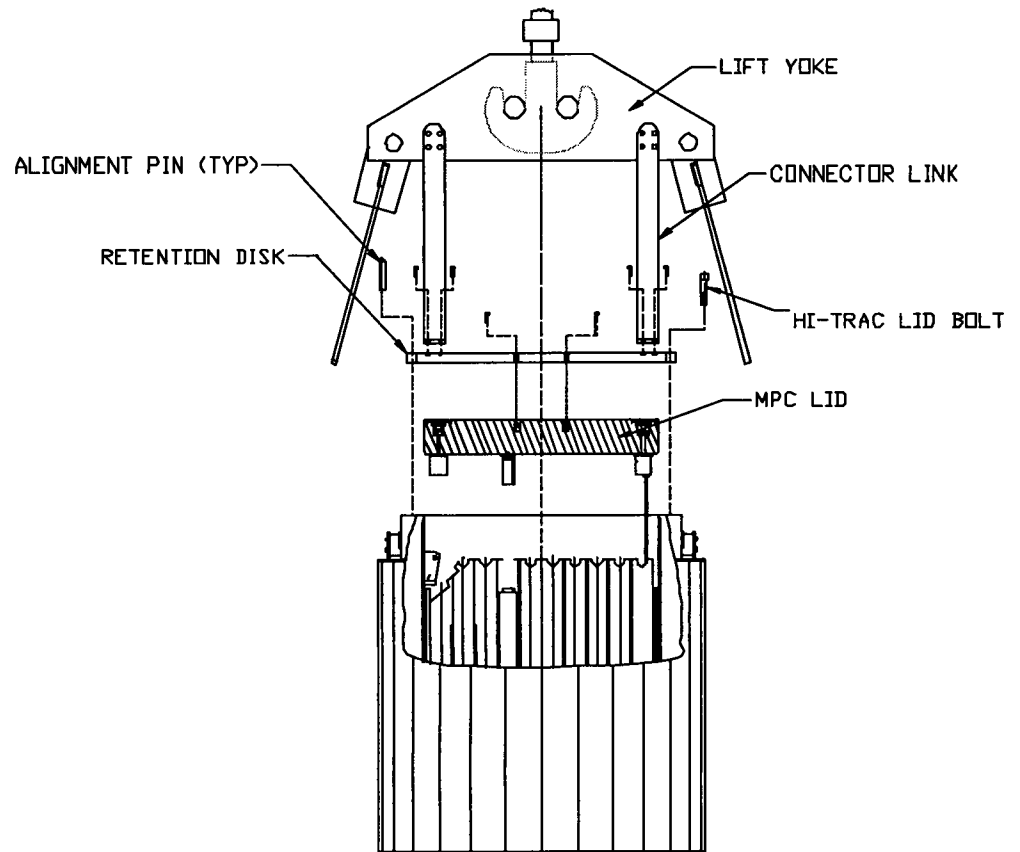
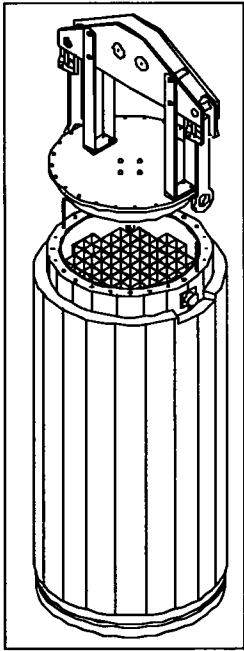


Figure 8.1.15; HI-TRAC Lid Retention System in Exploded View

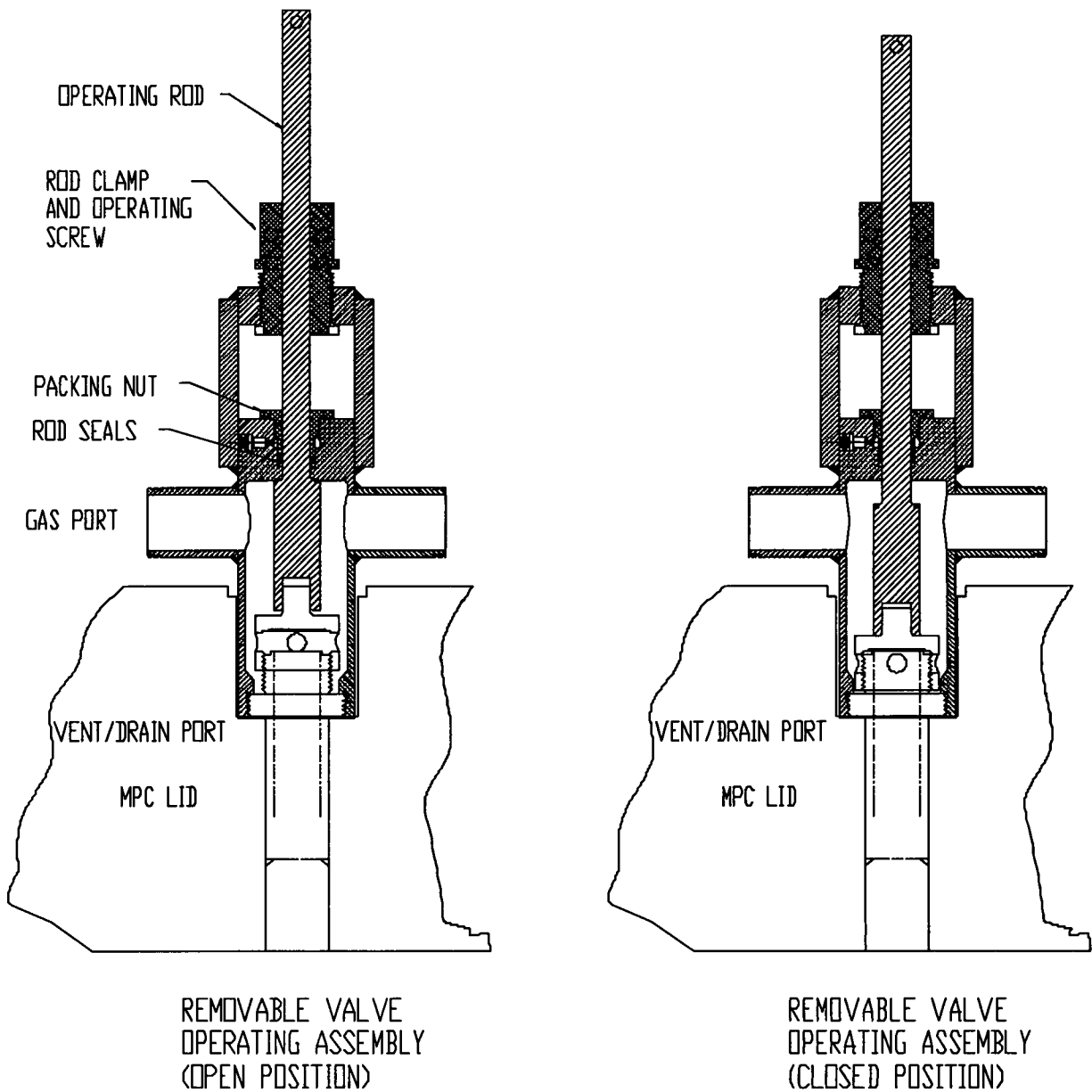


Figure 8.1.16; MPC Vent and Drain Port RVOA Connector

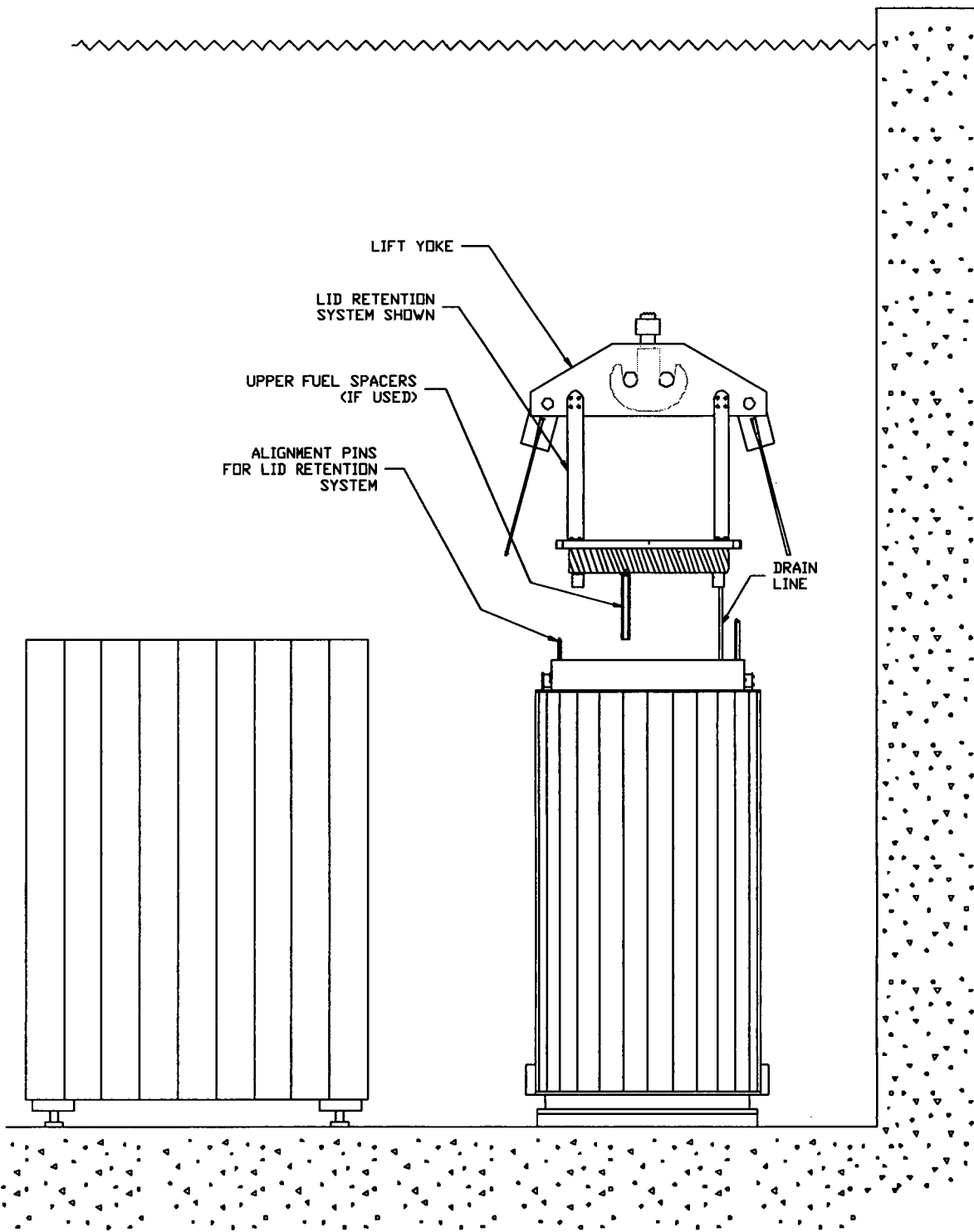


Figure 8.1.17; Drain Line Installation

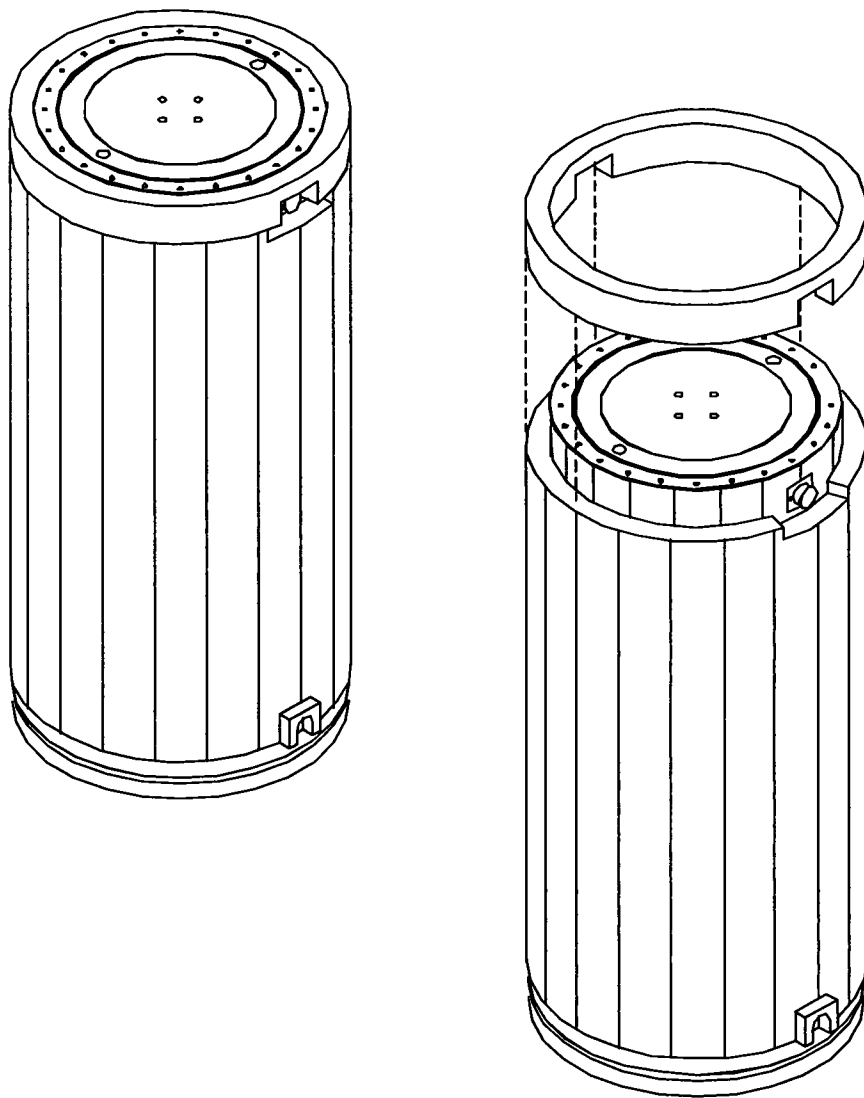


Figure 8.1.18; Temporary Shield Ring

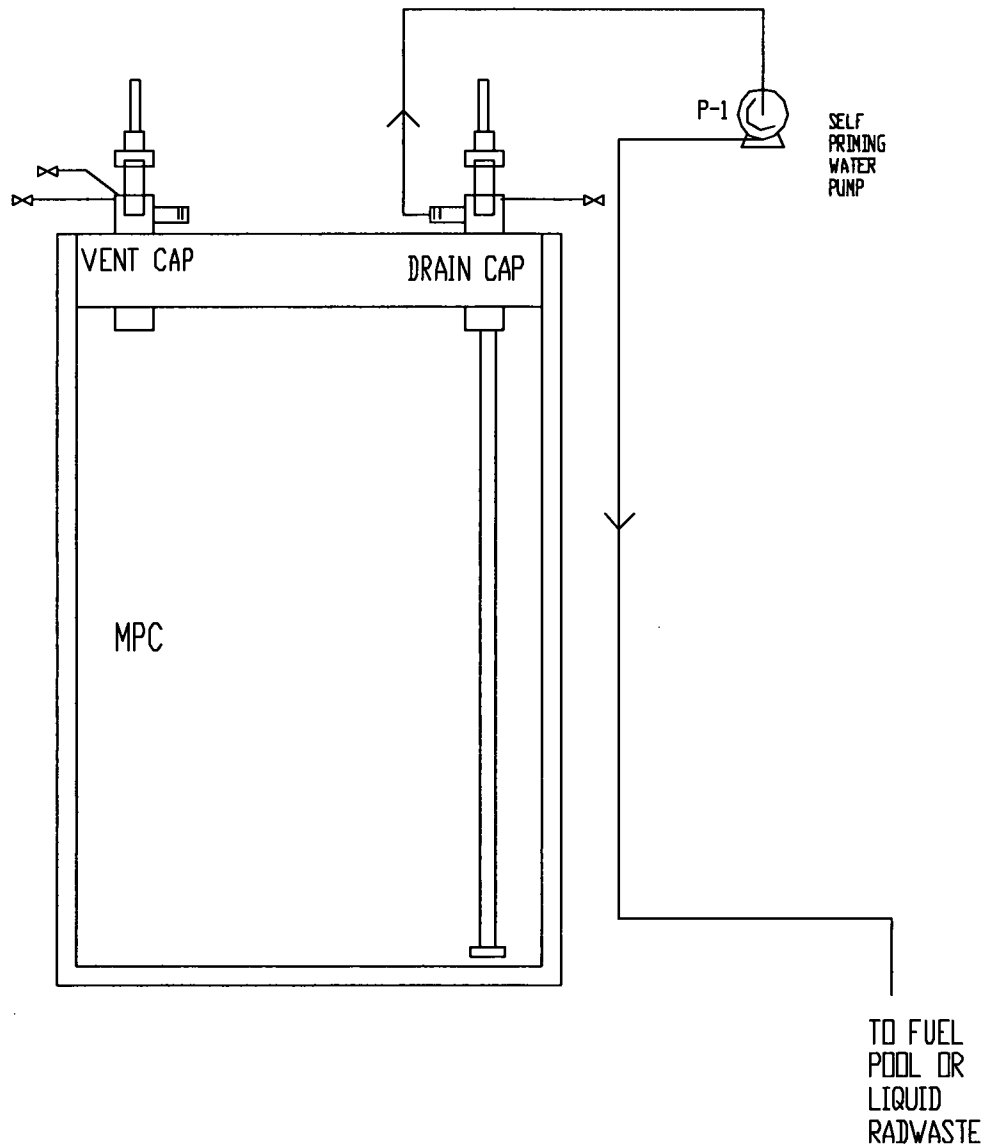


Figure 8.1.19; MPC Water Pump-Down for MPC Lid Welding Operations, Example P&I D

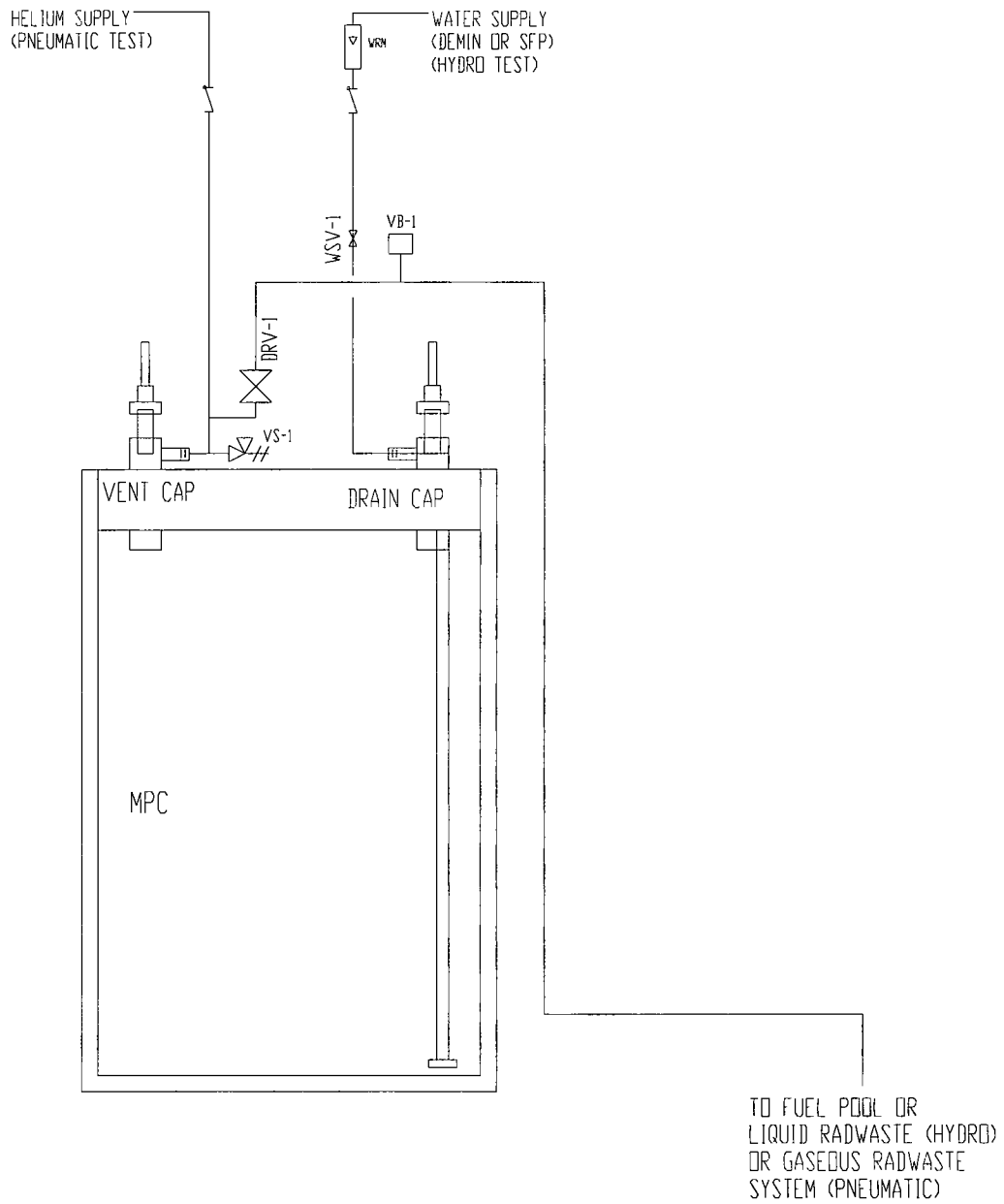


Figure 8.1.20; MPC Lid-to-Shell Pressure Testing, Example P&I D

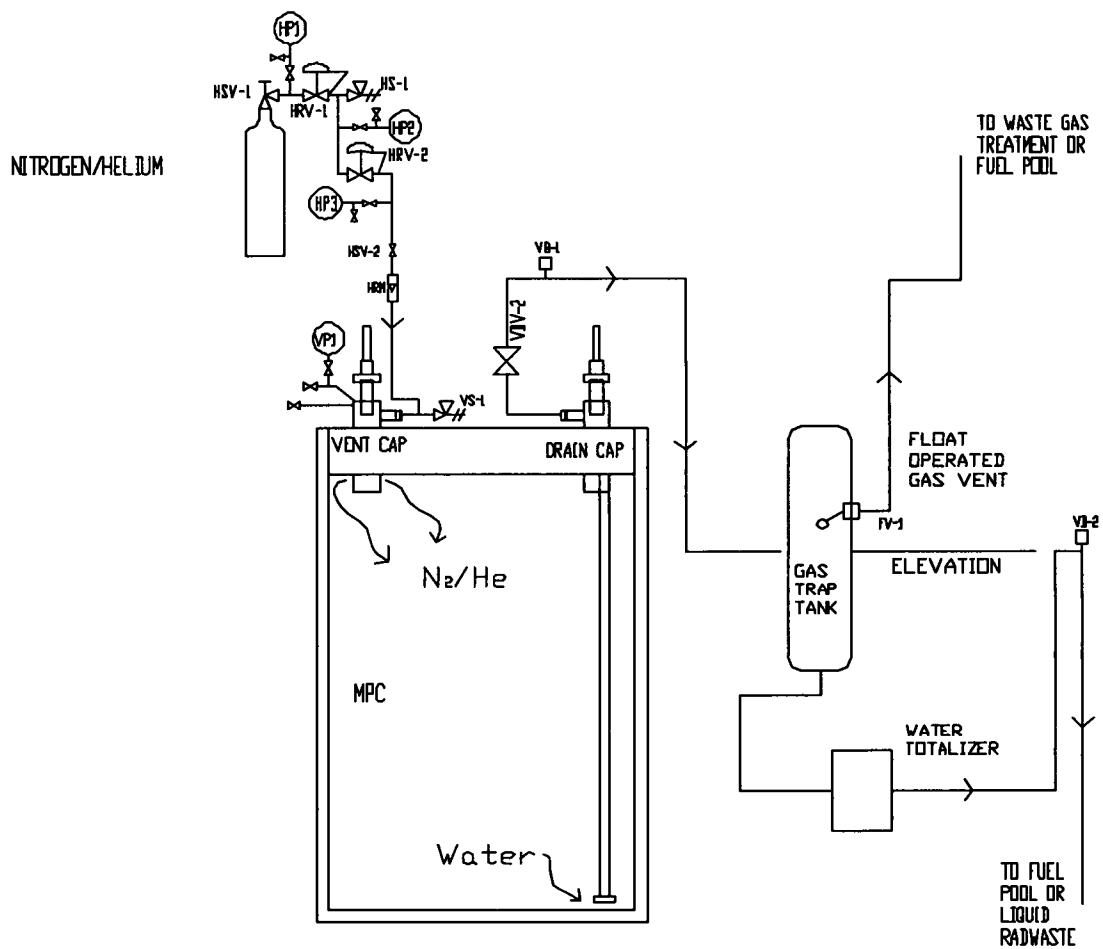


Figure 8.1.21; MPC Blowdown, Example P&I D

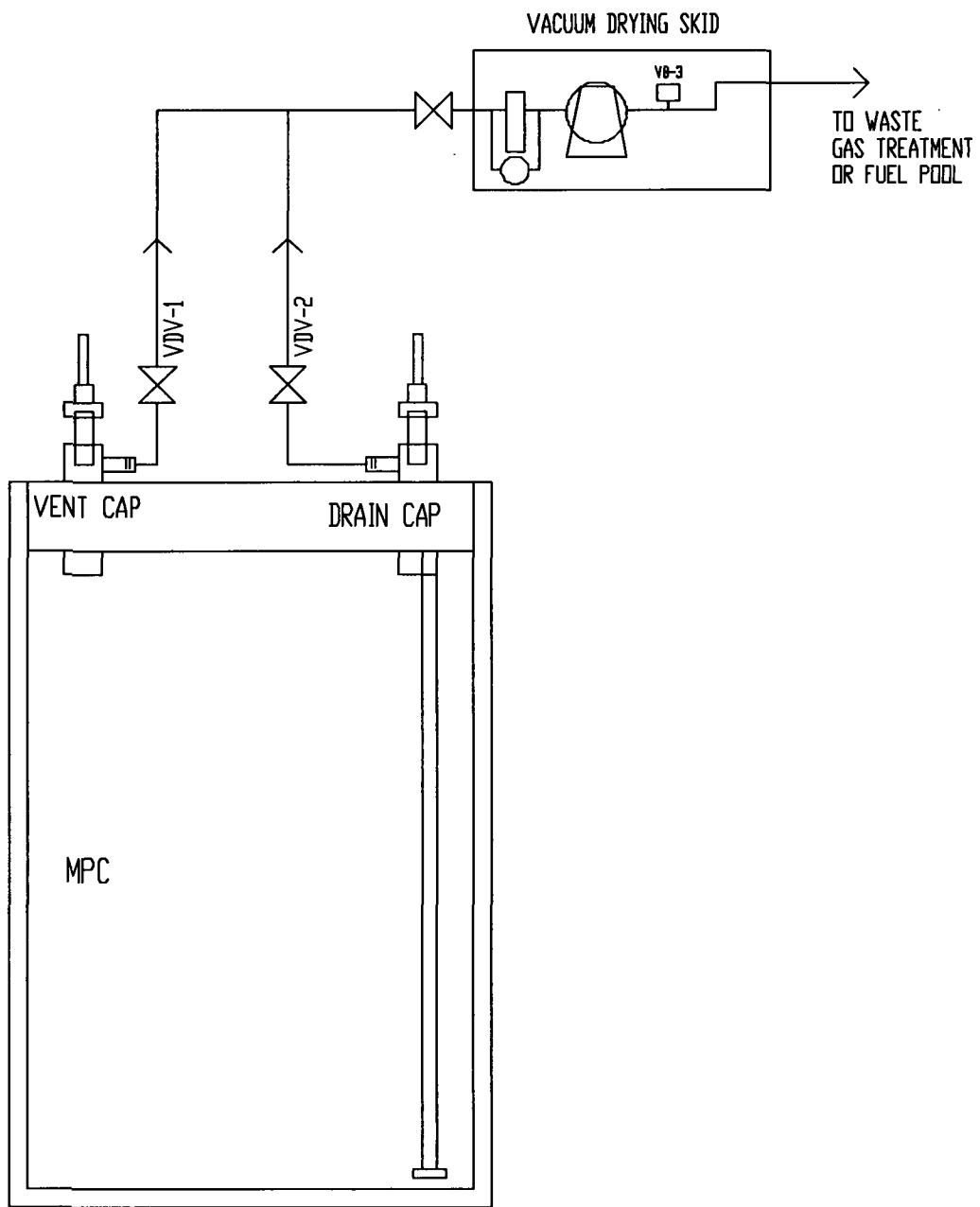


Figure 8.1.22a; Vacuum Drying System, Example P&I D

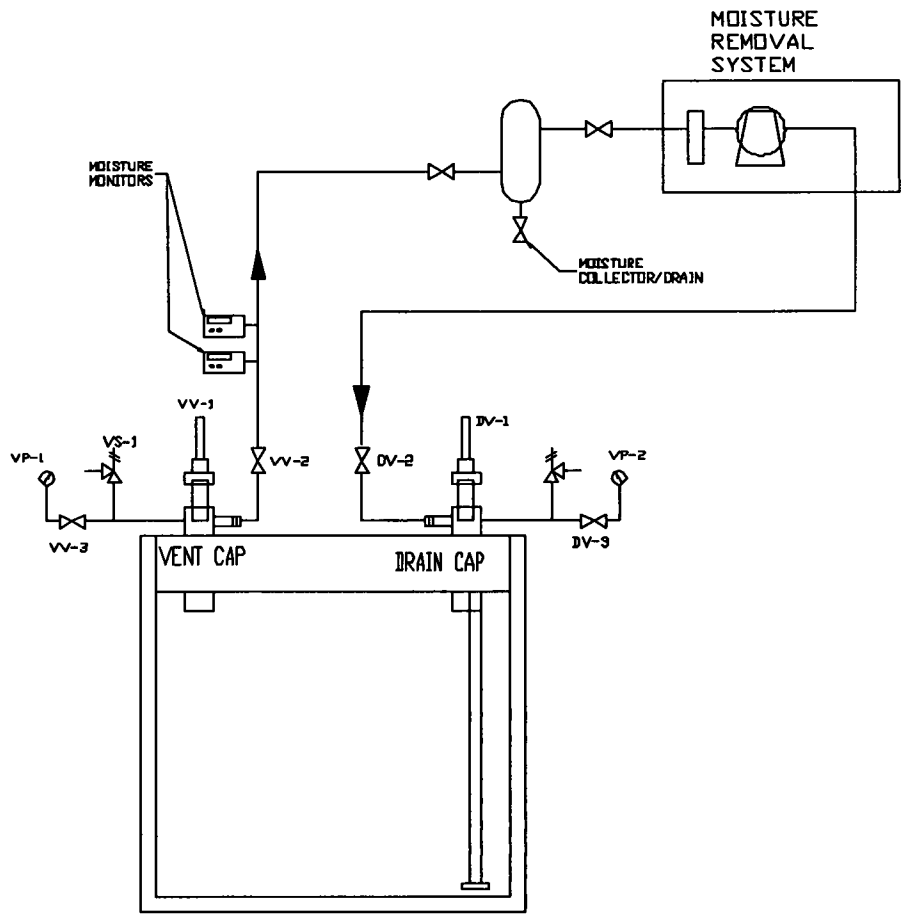


Figure 8.1.22b; forced Helium Dehydration System, Example P&I D

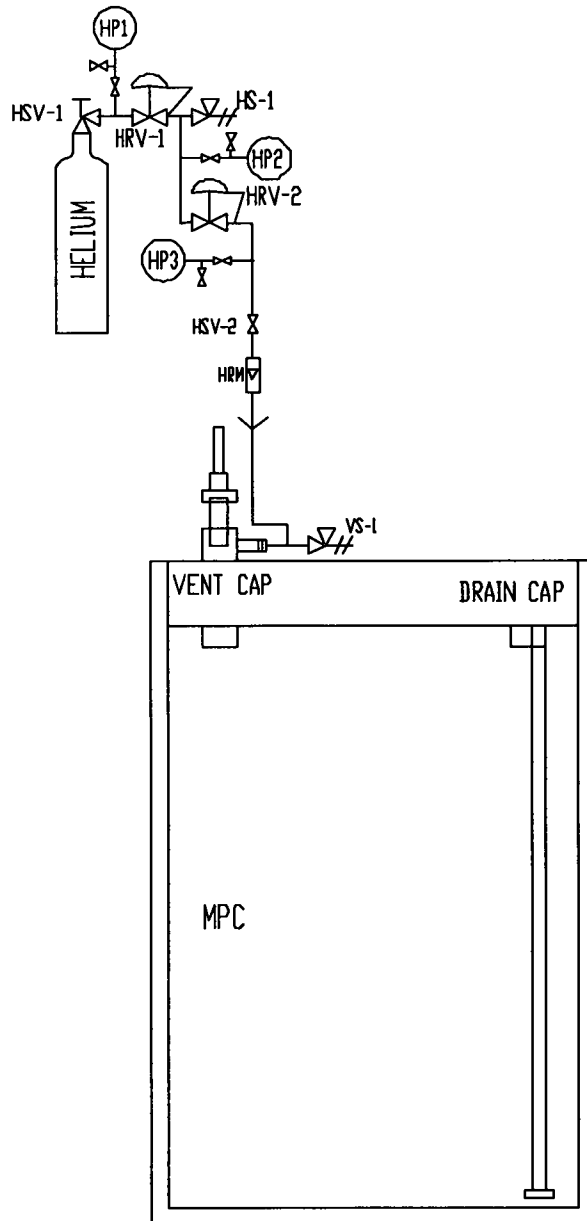


Figure 8.1.23; Helium Backfill System, Example P&I D

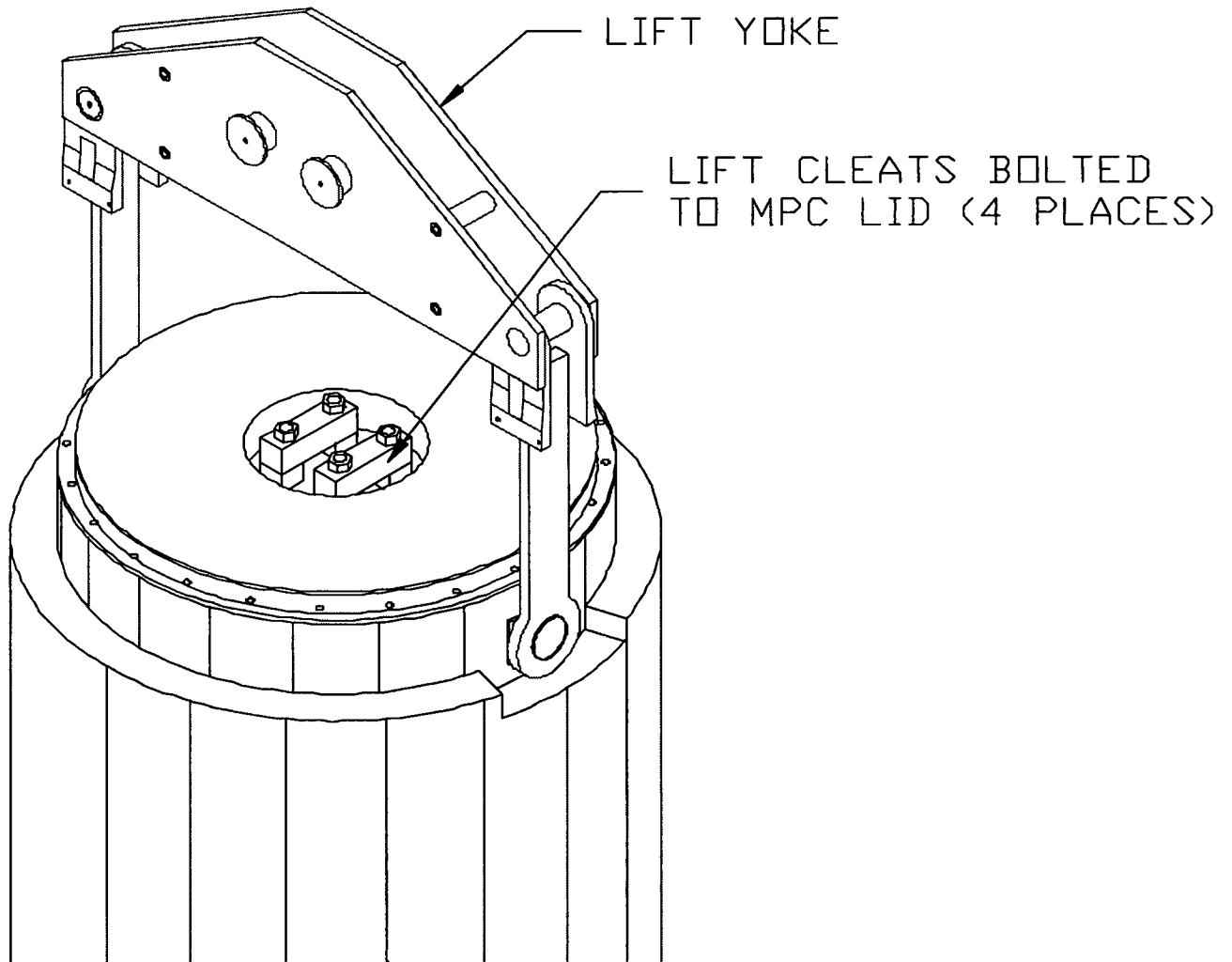
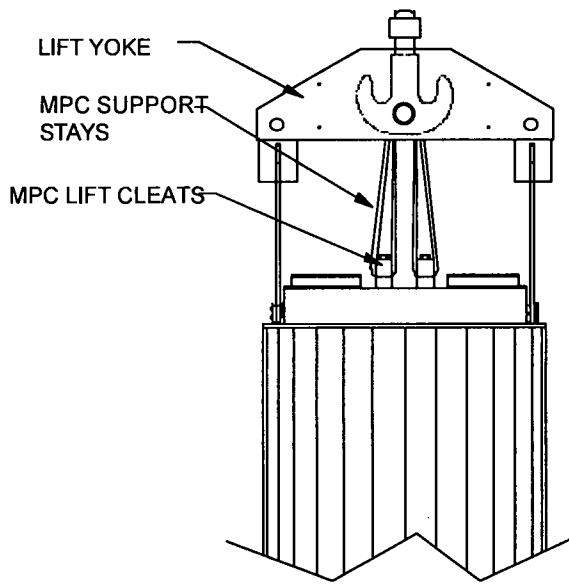
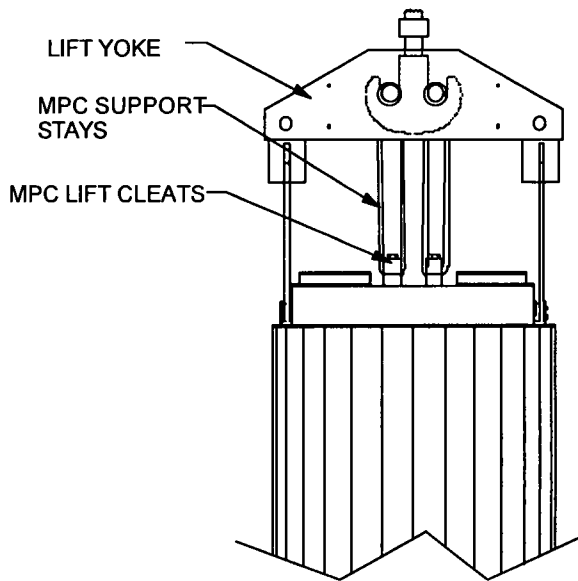


Figure 8.1.24; MPC Lift Cleats



SINGLE-PIN
ARRANGEMENT



DOUBLE-PIN
ARRANGEMENT

Figure 8.1.25; MPC Slings

NOTE:
CASK BODY REMAINS
STATIONARY (RIGGED FROM
CRANE HOOK) WHILE
BOTTOM LID IS MOVED
UNDERNEATH

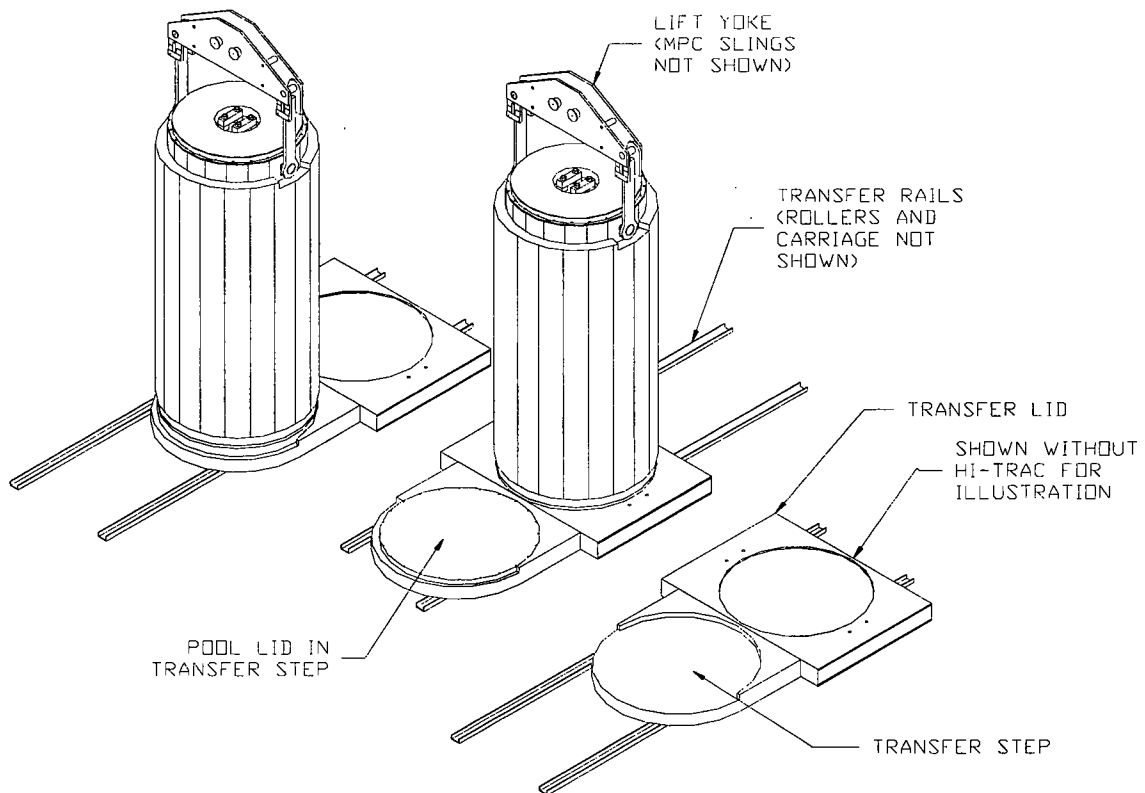


Figure 8.1.26; HI-TRAC Bottom Lid Replacement

(Not Required for HI-TRAC 100D and 125D)

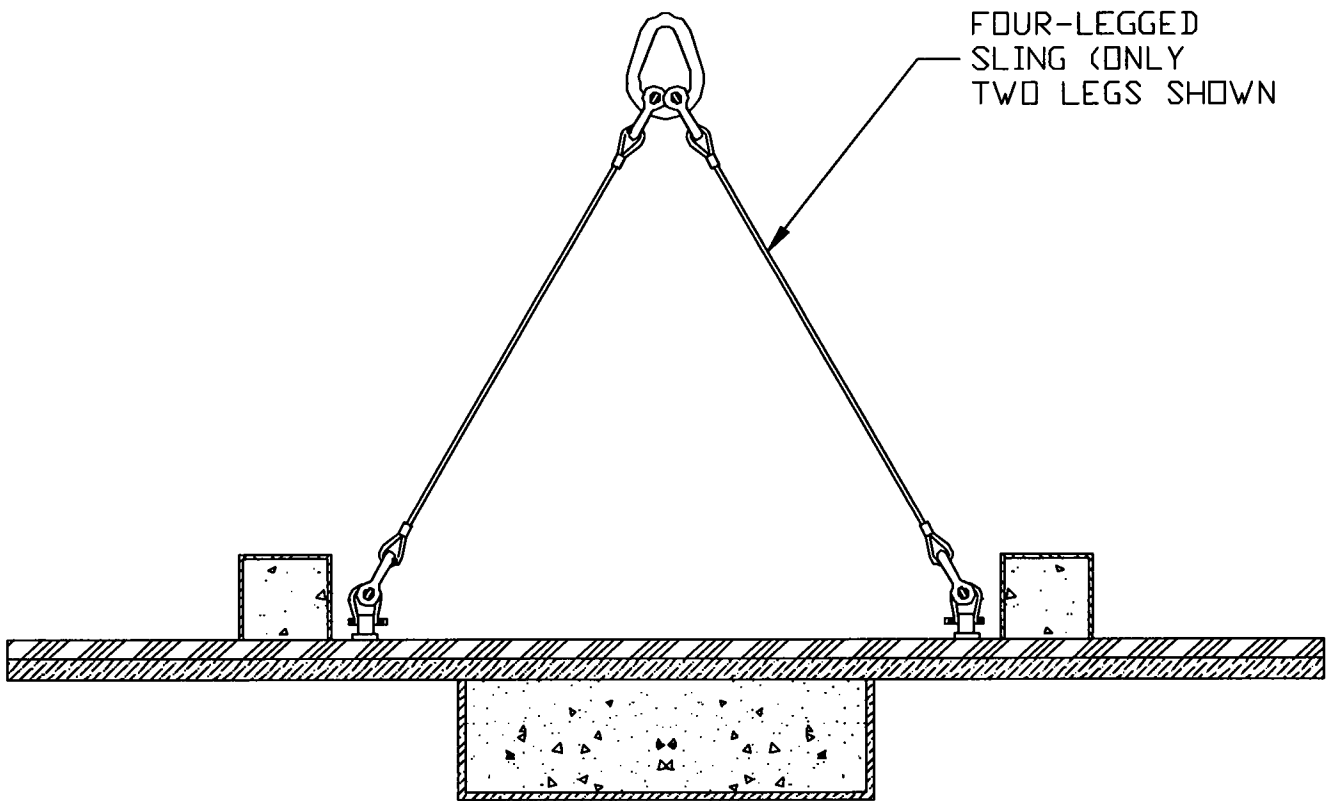
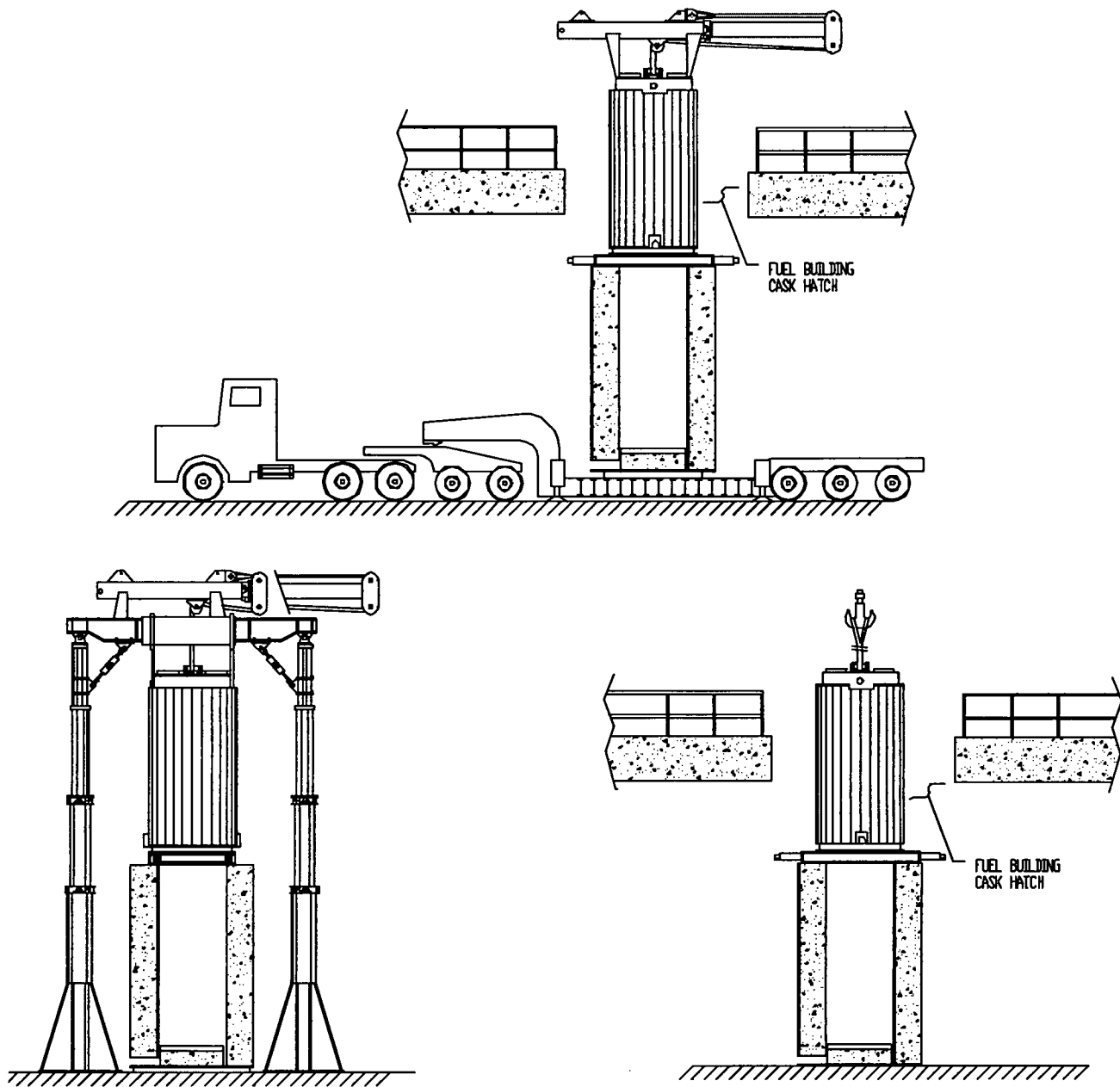


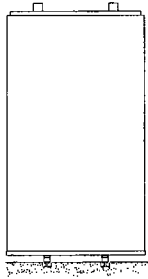
Figure 8.1.27; HI-STORM Lid Rigging

(HI-STORM 100 Lid Shown)

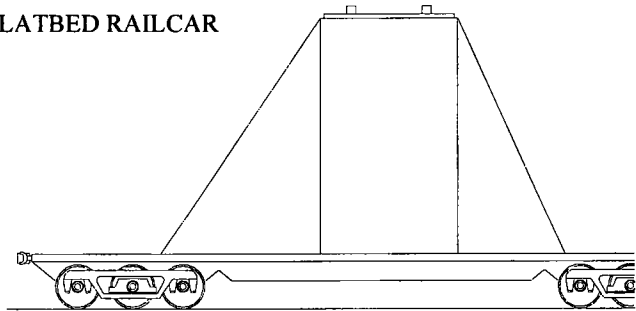


**Figure 8.1.28; Sample MPC Transfer Options
(HI-TRAC with Transfer Lid Shown)**

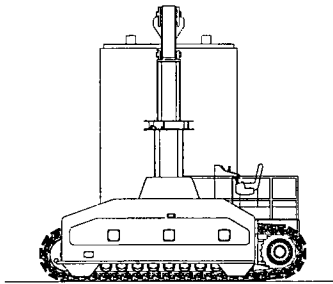
RAIL DOLLY



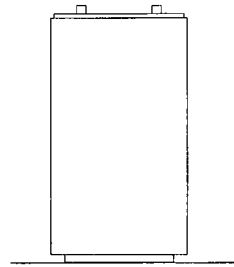
FLATBED RAILCAR



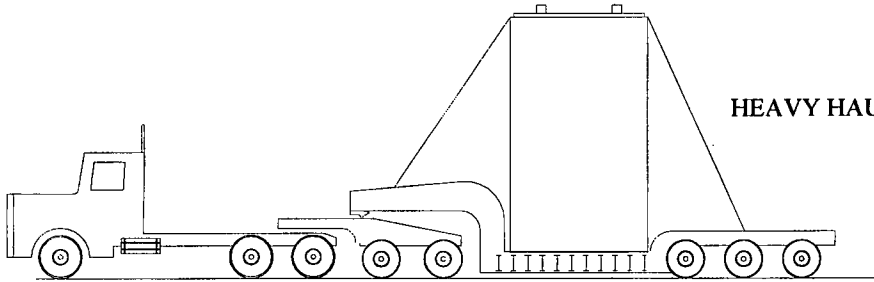
VERTICAL CASK
TRANSPORTER
("CRAWLER")



AIR PAD



HEAVY HAUL TRAILER



VERTICAL CASK
TRANSPORTER

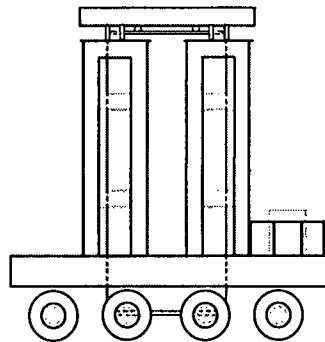
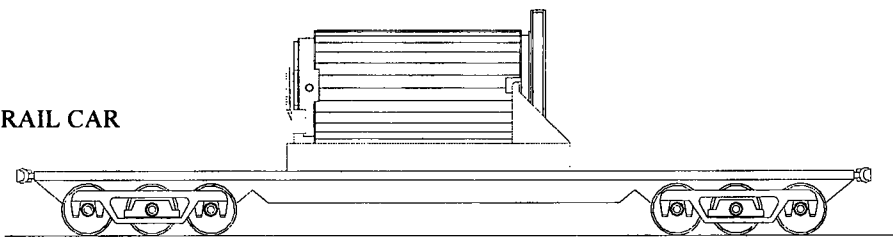
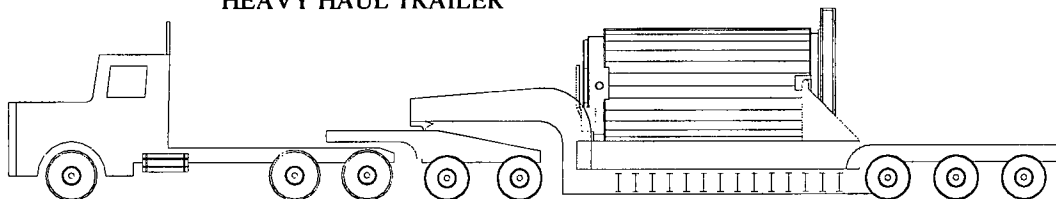


Figure 8.1.29a; Sample HI-STORM Transfer Options

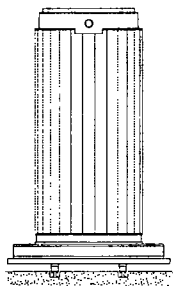
RAIL CAR



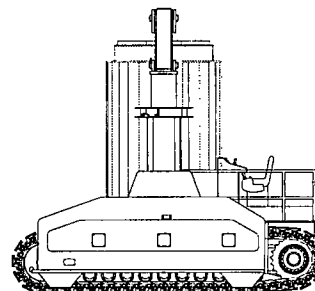
HEAVY HAUL TRAILER



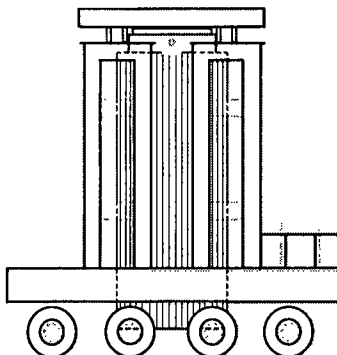
RAIL DOLLY



VERTICAL CASK TRANSPORTER
("CRAWLER")



VERTICAL CASK TRANSPORTER



**Figure 8.1.29b; Sample HI-TRAC Transfer Options
(HI-TRAC 100/125 Shown)**

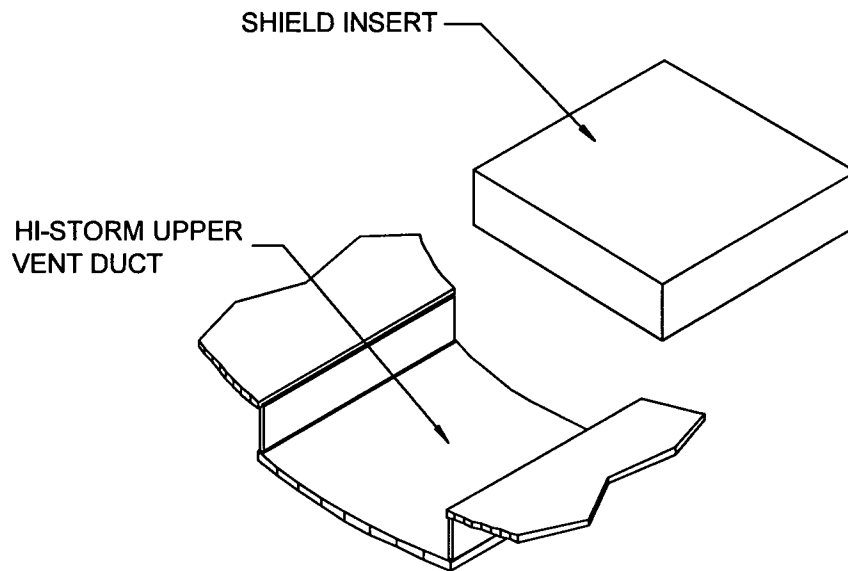
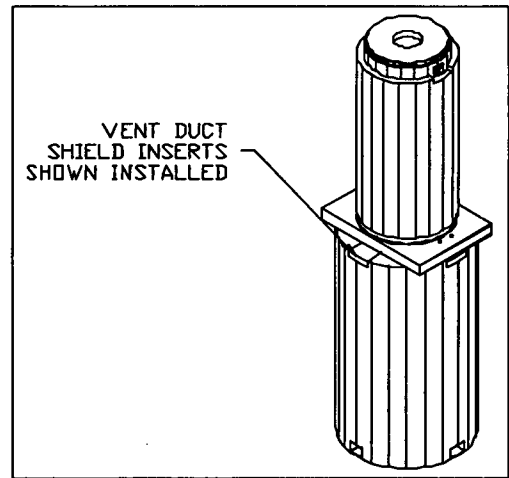
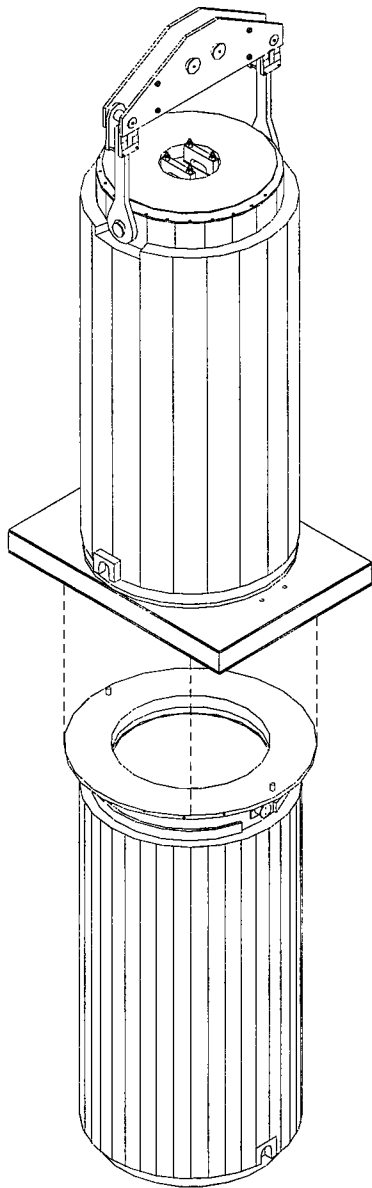
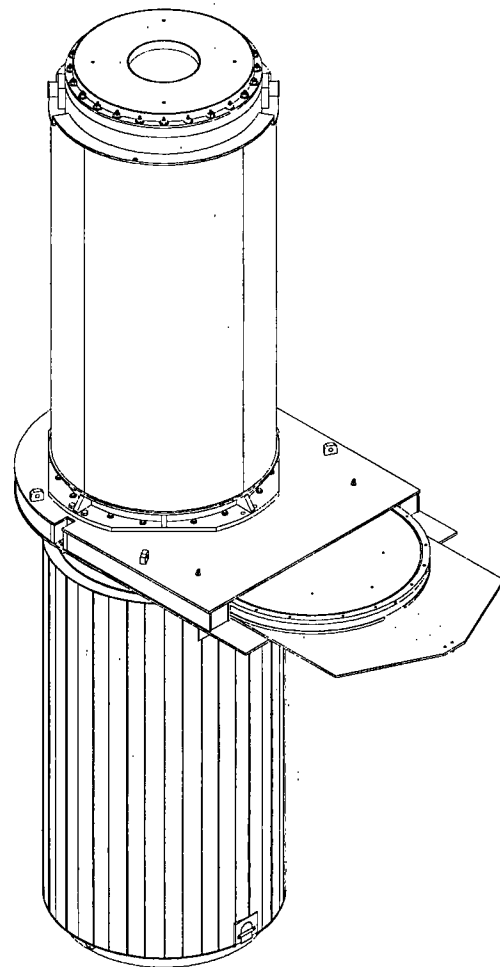


Figure 8.1.30; Sample HI-STORM Vent Duct Shield Inserts

(Not Required for HI-STORM 100S)

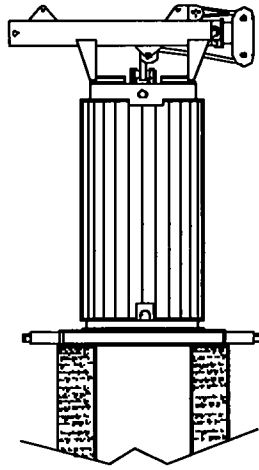


HI-TRAC 100 / 125

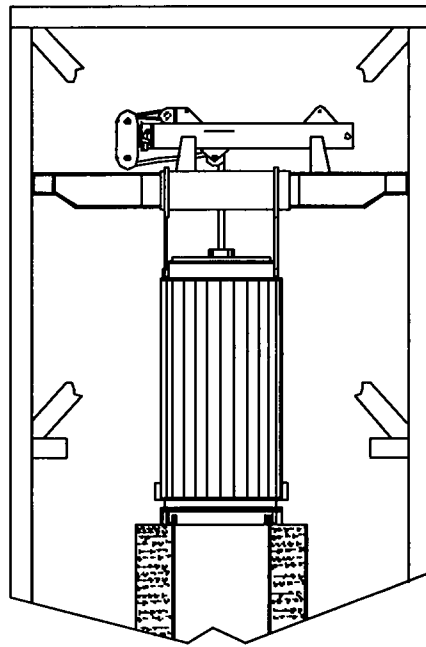


HI-TRAC 100D / 125D with Mating Device

Figure 8.1.31; HI-TRAC Alignment Over HI-STORM



MOUNTED TO THE HI-TRAC LID



MOUNTED TO A CASK TRANSFER GANTRY

Figure 8.1.32; Examples of an MPC Downloader

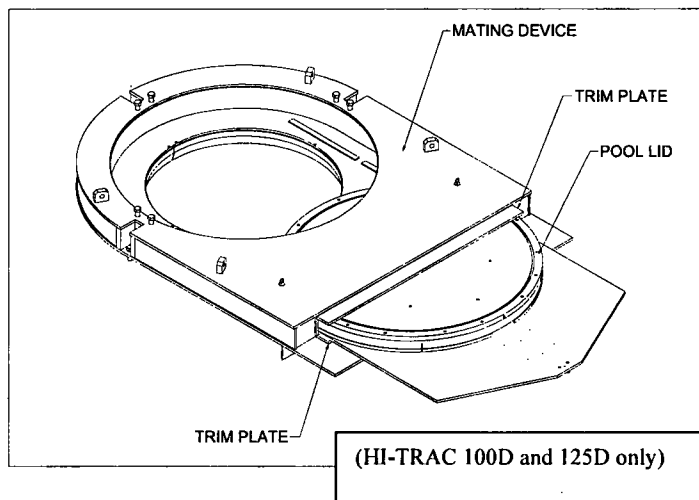
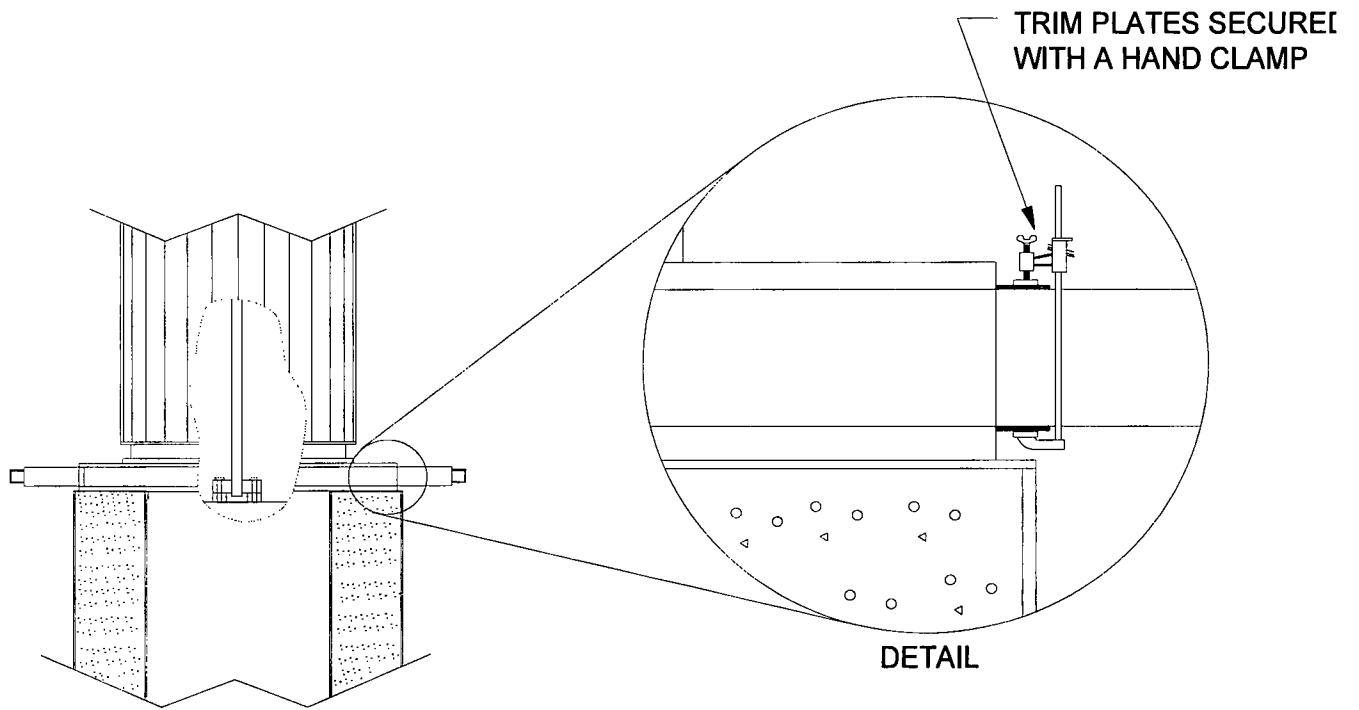


Figure 8.1.33; Trim Plate Locations

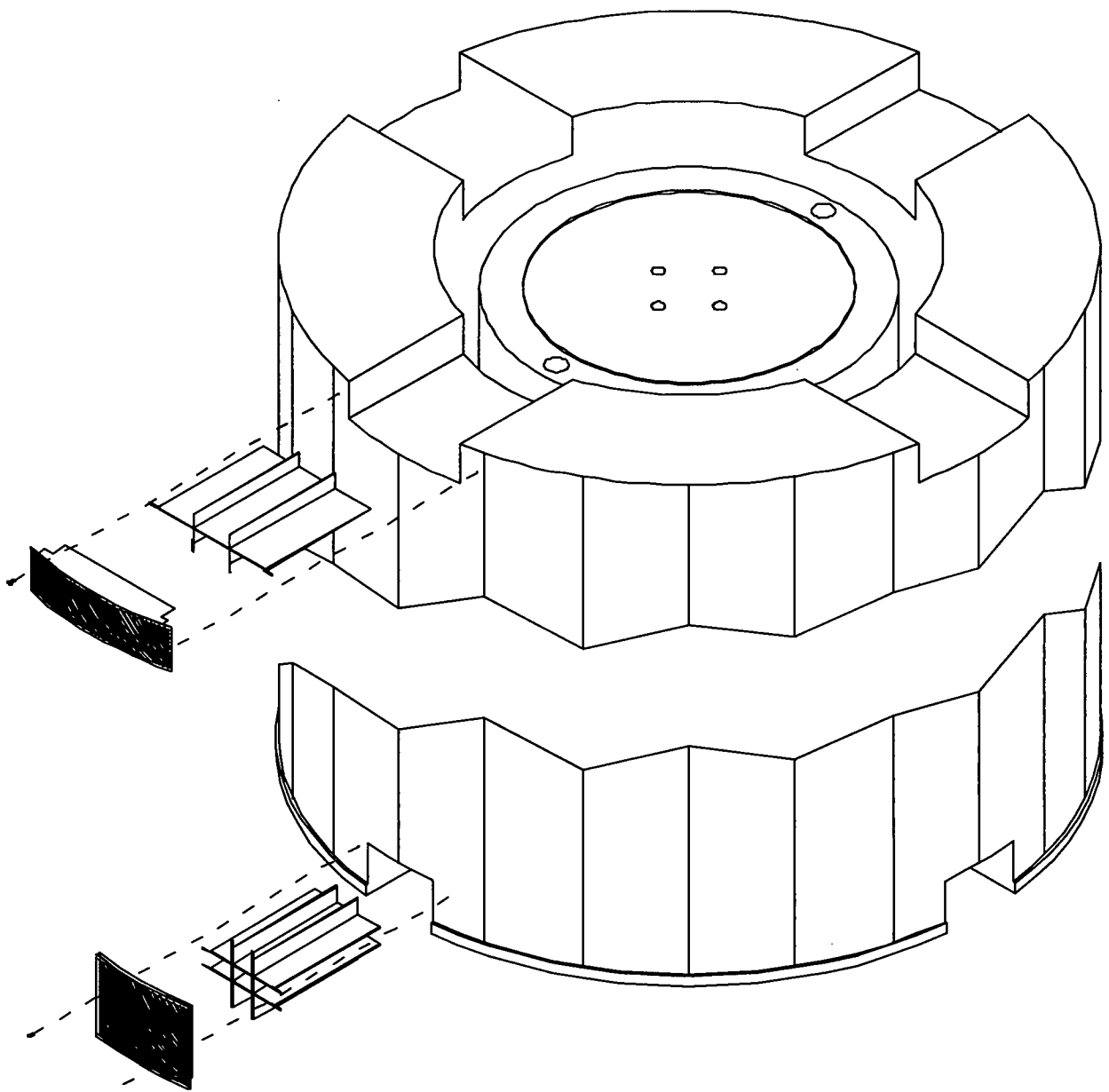


Figure 8.1.34a; Typical HI-STORM Vent Screen and Gamma Shield Cross Plate Installation

Figure 8.1.34b

Intentionally Deleted

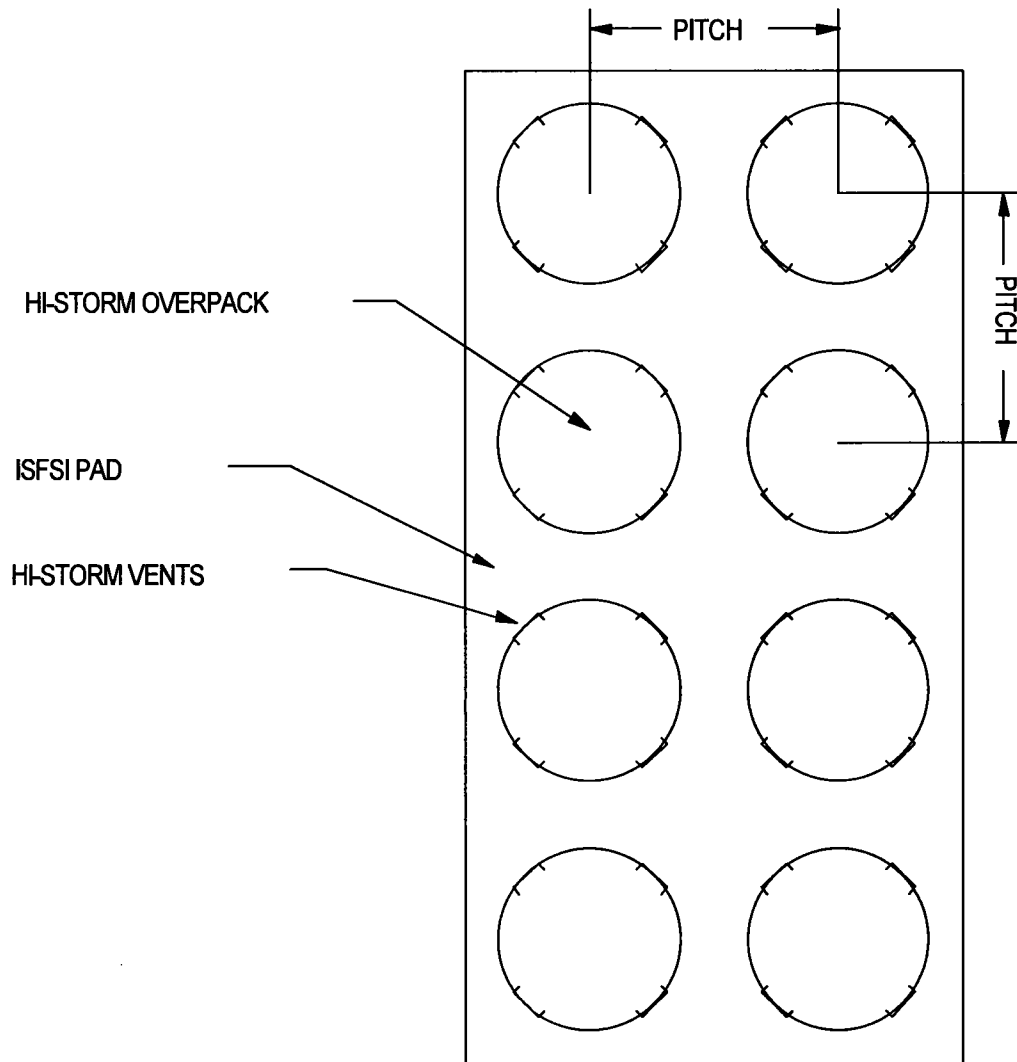


Figure 8.1.35; HI-STORM Placement of the ISFSI Pad

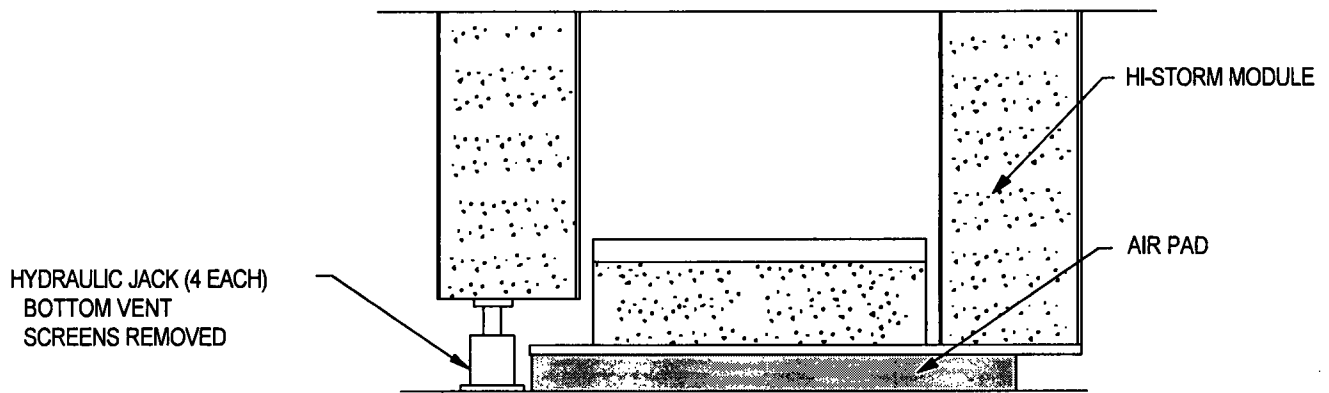
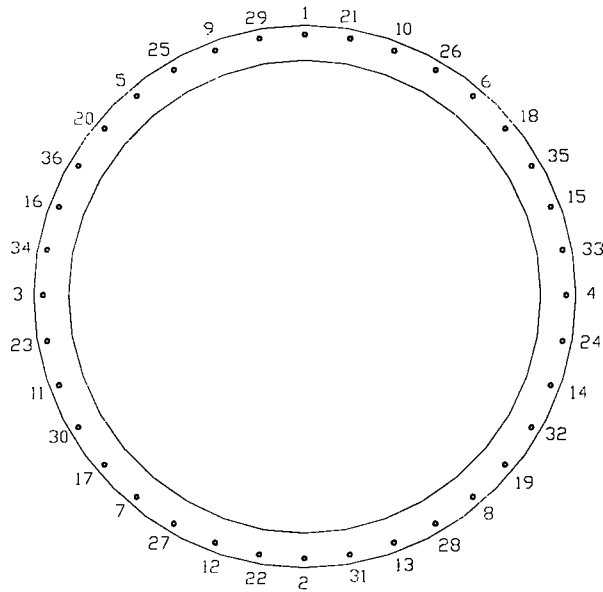
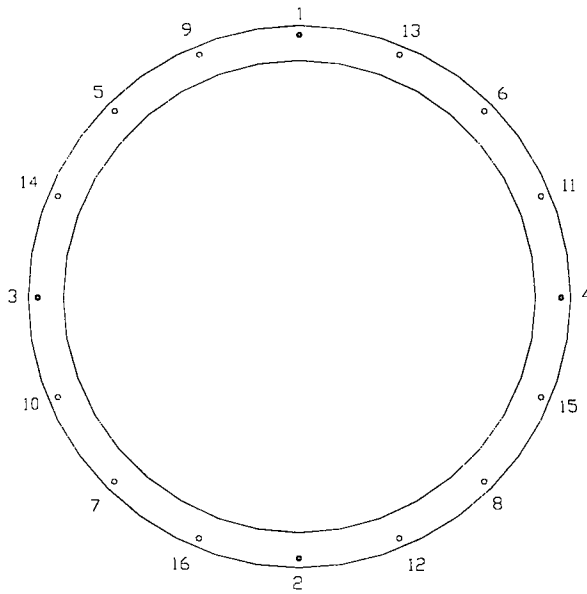


Figure 8.1.36; HI-STORM Jacking



HI-TRAC 100 / 125
 BOTTOM LID
 (POOL LID OR
 TRANSFER LID)



HI-TRAC
 100D / 125D
 POOL LID

Figure 8.1.37; HI-TRAC Lid Bolt Torquing Pattern

8.2 ISFSI OPERATIONS

The HI-STORM 100 System heat removal system is a totally passive system. Maintenance on the HI-STORM system is typically limited to cleaning and touch-up painting of the overpacks, repair and replacement of damaged vent screens, and removal of vent blockages (e.g., leaves, debris). The heat removal system operability surveillance should be performed after any event that may have an impact on the safe functioning of the HI-STORM system. These include, but are not limited to, wind storms, heavy snow storms, fires inside the ISFSI, seismic activity, flooding of the ISFSI, and/or observed animal or insect infestations. The responses to these conditions involve first assessing the dose impact to perform the corrective action (inspect the HI-STORM overpack, clear the debris, check the cask pitch, and/or replace damaged vent screens), perform the corrective action, verify that the system is operable (check ventilation flow paths and radiation). In the event of significant damage to the HI-STORM, the situation may warrant removal of the MPC, and repair or replacement of the damaged HI-STORM overpack. If necessary, the procedures in Section 8.1 may be used to reposition a HI-STORM overpack for minor repairs and maintenance. In extreme cases, Section 8.3 may be used as guidance for unloading the MPC from the HI-STORM.

Note:

The heat removal system operability surveillance involves performing a visual examination on the HI-STORM exit and inlet vent screens to ensure that the vents remain clear or verifying the temperature rise from ambient to outlet is within prescribed limits. The metallic vent screens if damaged may allow leaves, debris or animals to enter the duct and block the flow of air to the MPC.

ALARA Warning:

Operators should practice ALARA principals when inspecting the vent screens. In most cases, binoculars allow the operator to perform the surveillance from a low dose area.

- 8.2.1 Perform the heat removal operability surveillance.
- 8.2.2 ISFSI Security Operations shall be performed in accordance with the approved site security program plan.

8.3 PROCEDURE FOR UNLOADING THE HI-STORM 100 SYSTEM IN THE SPENT FUEL POOL

8.3.1 Overview of HI-STORM 100 System Unloading Operations

ALARA Note:

The procedure described below uses the weld removal system to remove the welds necessary to enable the MPC lid to be removed. Users may opt to remove some or all of the welds using hand operated equipment. The decision should be based on dose rates, accessibility, degree of weld removal, and available tooling and equipment.

The HI-STORM 100 System unloading procedures describe the general actions necessary to prepare the MPC for unloading, flood the MPC cavity, remove the lid welds, unload the spent fuel assemblies, and recover the HI-TRAC and empty MPC. Special precautions are outlined to ensure personnel safety during the unloading operations, and to prevent the risk of MPC over pressurization and thermal shock to the stored spent fuel assemblies. Figure 8.3.1 shows a flow diagram of the HI-STORM unloading operations. Figure 8.3.2 illustrates the major HI-STORM unloading operations.

Refer to the boxes of Figure 8.3.2 for the following description. The MPC is recovered from HI-STORM either at the ISFSI or the fuel building using the same methods as described in Section 8.1 (Box 1). The HI-STORM lid is removed, the vent duct shield inserts are installed, the alignment device (or mating device with pool lid for HI-TRAC 100D and 125D) is positioned, and the MPC lift cleats are attached to the MPC. The exit vent screens and gamma shield cross plates are removed as necessary. MPC slings are attached to the MPC lift cleat and positioned on the MPC lid. HI-TRAC is positioned on top of HI-STORM (Box 2) and the slings are brought through the HI-TRAC top lid. The MPC is raised into HI-TRAC, the HI-TRAC doors (or mating device drawer) are closed and the locking pins are installed. If the mating device and HI-TRAC 100D or 125D are used, the pool lid is bolted to the HI-TRAC. The HI-TRAC is removed from on top of HI-STORM. If the HI-TRAC 100D and 125D are not used, the HI-TRAC is positioned in the transfer slide and the transfer lid is replaced with the pool lid (Box 3) using the same method as with the loading operations.

If a Supplemental Cooling System (SCS) is required by the TS, it is connected to the HI-TRAC annulus following transfer from the HI-STORM to the HI-TRAC and used to circulate coolant to maintain fuel cladding temperatures below ISG-11 Rev. 3 limits. HI-TRAC and its enclosed MPC are returned to the designated preparation area and the MPC slings and MPC lift cleats are removed. The temporary shield ring is installed on the HI-TRAC upper section and filled with plant demineralized water. The HI-TRAC top lid is removed¹ (Box 4) and water is added to the annulus. If SCS is not being used, water is fed into the annulus through the drain port to cool the MPC shell. After filling the annulus with water the annulus and HI-TRAC top surfaces are covered to protect them from debris produced when removing the MPC lid. The weld removal system is installed (Box 7) and the MPC vent and drain ports are accessed (Box 5). The vent RVOA is attached to the vent port and an evacuated sample bottle is connected. The vent port is

¹ Users with the optional HI-TRAC Lid Spacer shall modify steps in their procedures to install and remove the spacer together with top lid.

slightly opened to allow the sample bottle to obtain a gas sample from inside the MPC. A gas sample is performed to assess the condition of the fuel assembly cladding. A vent line is attached to the vent port and the MPC is vented to the fuel building ventilation system or spent fuel pool as determined by the site's radiation protection personnel. The MPC is filled with water (borated as required) at a controlled rate to avoid over pressurizing the MPC (Box 6) and the supplemental cooling system, if used, is terminated. The weld removal system then removes the MPC lid-to-shell weld. The weld removal system is removed with the MPC lid left in place (Box 7).

The top surfaces of the HI-TRAC and MPC are cleared of metal shavings. The inflatable annulus seal is installed and pressurized. The MPC lid is rigged to the lift yoke or lid retention system and the lift yoke is engaged to HI-TRAC lifting trunnions. If weight limitations require, the neutron shield jacket is drained of water. HI-TRAC is placed in the spent fuel pool and the MPC lid is removed (Boxes 8 and 9). All fuel assemblies are returned to the spent fuel storage racks and the MPC fuel cells are vacuumed to remove any assembly debris and crud (Box 10). HI-TRAC and MPC are returned to the designated preparation area (Box 11) where the MPC water is pumped back into the spent fuel pool or liquid radwaste facility. The annulus water is drained and the MPC and overpack are decontaminated (Box 12 and 13).

8.3.2 HI-STORM Recovery from Storage

Note:
The MPC transfer may be performed using the MPC downloader or the overhead crane.
Note:
The site-specific transport route conditions must satisfy the requirements of the technical specification.

1. Recover the MPC from HI-STORM as follows:
 - a. If necessary, perform a transport route walkdown to ensure that the cask transport conditions are met.
 - b. Transfer HI-STORM to the fuel building or site designated location for the MPC transfer.
 - c. Position HI-STORM under the lifting device.
 - d. Remove the HI-STORM lid nuts, washers and studs or lid closure bolts.
 - e. Remove the HI-STORM lid lifting hole plugs and install the lid lifting sling. See Figure 8.1.27.

Note:
The specific sequence for vent screen, temperature element, and gamma shield cross plate removal may vary based on the mode(s) or transport.

- f. Remove the HI-STORM exit vent screens, temperature elements and gamma shield cross plates. See Figure 8.1.34a.

Warning:

Unless the lift is single-failure proof (or equivalent safety factor) for the HI-STORM lid, the lid shall be kept less than 2 feet above the top surface of the overpack. This is performed to protect the MPC lid from a potential HI-STORM 100 lid drop.

- g. Remove the HI-STORM lid. See Figure 8.1.27.
 - h. Install the alignment device (or mating device with pool lid for HI-TRAC 100D and 125D) and vent duct shield inserts (HI-STORM 100 only). See Figure 8.1.30.
 - i. Deleted.
 - j. Remove the MPC lift cleat hole plugs and install the MPC lift cleats and MPC slings to the MPC lid. See Table 8.1.5 for torque requirements.
 - k. If necessary, install the top lid on HI-TRAC. See Figure 8.1.9 for rigging. See Table 8.1.5 for torque requirements.
 - l. Deleted.
2. If necessary, configure HI-TRAC with the transfer lid (Not required for HI-TRAC 100D and 125D):

ALARA Warning:

The bottom lid replacement as described below may only be performed on an empty (i.e., no MPC) HI-TRAC.

- a. Position HI-TRAC vertically adjacent to the transfer lid. See Section 8.1.2.
 - b. Remove the bottom lid bolts and plates and store them temporarily.
 - c. Raise the empty HI-TRAC and position it on top of the transfer lid.
 - d. Inspect the pool lid bolts for general condition. Replace worn or damaged bolts with new bolts.
 - e. Install the transfer lid bolts. See Table 8.1.5 for torque requirements.
3. At the site's discretion, perform a HI-TRAC receipt inspection and cleanliness inspection in accordance with a site-specific inspection checklist.

Note:

If the HI-TRAC is expected to be operated in an environment below 32 °F, the water jacket shall be filled with an ethylene glycol solution (25% ethylene glycol). Otherwise, the jacket shall be filled with demineralized water.

4. If previously drained, fill the neutron shield jacket with plant demineralized water or an ethylene glycol solution (25% ethylene glycol) as necessary. Ensure that the fill and drain plugs are installed.

HOLTEC INTERNATIONAL COPYRIGHTED MATERIAL

HI-STORM FSAR
REPORT HI-2002444

8.3-3

Rev. 12

5. Engage the lift yoke to the HI-TRAC lifting trunnions.
6. Align HI-TRAC over HI-STORM and mate the overpacks. See Figure 8.1.31.
7. If necessary, install the MPC downloader.
8. Remove the transfer lid (or mating device) locking pins and open the doors (mating device drawer).

ALARA Warning:

If trim plates are not used, personnel should remain clear of the immediate door area during MPC downloading since there may be some radiation streaming during MPC raising and lowering operations.

9. At the user's discretion, install trim plates to cover the gap above and below the door (drawer for 100D and 125D). The trim plates may be secured using hand clamps or any other method deemed suitable by the user. See Figure 8.1.33.
10. Attach the ends of the MPC sling to the lifting device or MPC downloader. See Figure 8.1.32.

Caution:

Limitations for handling an MPC containing high burn-up fuel and total MPC heat load greater than the threshold heat load setting in Table 4.5.4 at the time of unloading in a HI-TRAC are evaluated and established on a canister basis to ensure that acceptable cladding temperatures are not exceeded. Refer to FSAR Section 4.5 for guidance. The Supplemental Cooling System (SCS) is used to prevent fuel cladding temperatures from exceeding ISG-11 Rev. 3 limits. Operation of the SCS is initiated in accordance with the TS and continues until MPC re-flooding operations have commenced. Staging and check-out of the SCS shall be completed prior to transferring the MPC to the HI-TRAC.

11. Raise the MPC into HI-TRAC.
12. Verify the MPC is in the full-up position.
13. Close the HI-TRAC doors (or mating device drawer) and install the door locking pins.
14. For the HI-TRAC 100D and 125D, bolt the pool lid to the HI-TRAC. See Table 8.1.5 for torque requirements.
15. Lower the MPC onto the transfer lid doors (or pool lid for 100D and 125D).
16. Disconnect the slings from the MPC lift cleats.
17. If necessary, remove the MPC downloader from the top of HI-TRAC.
18. Remove HI-TRAC from the top of HI-STORM.

Note:

For the HI-TRAC 100 and HI-TRAC 125, operation of the SCS may need to be postponed until the pool lid is in place on the HI-TRAC. In any event, the supplemental cooling system shall be initiated in accordance with the TS.

19. Replace the transfer lid with the pool lid as follows (Not required for HI-TRAC 100D and 125D):
 - a. Lower the lift yoke and attach the MPC slings between the lift cleats and the lift yoke. See Figure 8.1.25.
 - b. Engage the lift yoke to the HI-TRAC lifting trunnions.
 - c. Deleted.
 - d. Raise HI-TRAC and position the transfer lid approximately one inch above the transfer step. See Figure 8.1.26.
 - e. Raise the transfer slide carriage so the transfer carriage is supporting the transfer lid bottom. Remove the transfer lid bolts and store them temporarily.

ALARA Warning:

Clear all personnel away from the immediate operations area. The transfer slide carriage and jacks are remotely operated. The carriage has fine adjustment features to allow precise positioning of the lids.

- f. Lower the transfer carriage and position the pool lid under HI-TRAC.
- g. Raise the transfer slide carriage to place the pool lid against the HI-TRAC bottom lid bolting flange.
- h. Inspect the bottom lid bolts for general condition. Replace worn or damaged bolts with new bolts.
- i. Install the pool lid bolts. See Table 8.1.5 for torque requirements.
- j. If required, attach the SCS to the HI-TRAC annulus and begin circulating coolant. (See Figure 2.C.1) Continue operation of the SCS until MPC re-flooding operations have commenced.
- k. Raise and remove the HI-TRAC from the transfer slide.
- l. Disconnect the MPC slings and lift cleats.

Warning:

At the start of SCS operations, annulus fill water may flash to steam due to high MPC shell temperatures. Users may select the location and means of filling the annulus. Water addition should be performed in a slow and controlled manner until water steam generation has ceased.

20. If required, attach the SCS to the HI-TRAC annulus and begin circulating coolant. (See Figure 2.C.1). Continue operation of the SCS until MPC re-flooding operations have commenced.

8.3.3 Preparation for Unloading:

1. Place HI-TRAC in the designated preparation area.

Warning:

Unless the lift is single-failure proof (or equivalent safety factor) for the HI-TRAC top lid, the top lid shall be kept less than 2 feet above the top surface of the MPC. This is performed to protect the MPC lid from a potential lid drop.

2. Prepare for MPC cool-down.
3. Remove the top lid bolts and remove HI-TRAC top lid. See Figure 8.1.9 for rigging.

Warning:

At the start of annulus filling, the annulus fill water may flash to steam due to high MPC shell temperatures. Water addition should be performed in a slow and controlled manner until water steam generation has ceased.

4. Set the annulus water level to approximately 4 inches below the top of the MPC shell and install the annulus shield. Cover the annulus and HI-TRAC top surfaces to protect them from debris produced when removing the MPC lid.
5. Access the MPC as follows:

ALARA Note:

The following procedures describe weld removal using a machine tool head. Other methods may also be used. The metal shavings may need to be periodically vacuumed.

ALARA Warning:

Weld removal may create an airborne radiation condition. Weld removal must be performed under the direction of the user's Radiation Protection organization.

- a. Install bolt plugs and/or waterproof tape on the HI-TRAC top bolt holes.
 - b. Using the marked locations of the vent and drain ports, core drill the closure ring and vent and drain port cover plates.
6. Remove the closure ring section and the vent and drain port cover plates.

ALARA Note:

The MPC vent and drain ports are equipped with metal-to-metal seals to minimize leakage and withstand the long-term effects of temperature and radiation. The vent and drain port design prevents the need to hot tap into the penetrations during unloading operation and eliminate the risk of a pressurized release of gas from the MPC.

7. Take an MPC gas sample as follows:

Note:

Users may select alternate methods of obtaining a gas sample.

- a. Attach the RVOAs (See Figure 8.1.16).
- b. Attach a sample bottle to the vent port RVOA as shown on Figure 8.3.3.
- c. Evacuate the RVOA and Sample Bottle.
- d. Slowly open the vent port cap using the RVOA and gather a gas sample from the MPC internal atmosphere.
- e. Close the vent port cap and disconnect the sample bottle.

ALARA Note:

The gas sample analysis is performed to determine the condition of the fuel cladding in the MPC. The gas sample may indicate that fuel with damaged cladding is present in the MPC. The results of the gas sample test may affect personnel protection and how the gas is processed during MPC depressurization.

- f. Turn the sample bottle over to the site's Radiation Protection or Chemistry Department for analysis.
- g. Deleted.

8. Fill the MPC cavity with water as follows:

Caution:

This Caution block is required by the HI-STORM 100 CoC (CoC Appendix B, Section 3.4.10 and CoC Appendix B-100U, Section 3.4.12) and may not be deleted without prior NRC approval via CoC amendment. To prevent the oxidation of the fuel the MPC interior shall be filled with helium or another suitable inert gas to avoid exposing the fuel to oxidizing agents while at elevated temperatures. Exposing fuel at elevated temperatures to oxidizing agents can lead to deleterious oxidation of the fuel.

- a. Open the vent and drain port caps using the RVOAs.
- b. Deleted.
- c. Deleted.
- d. Deleted.
- e. Deleted.
- f. Deleted.
- g. Deleted.
- h. Deleted.

Caution:

The introduction of water into the MPC may create steam. Re-flooding operations shall be

HOLTEC INTERNATIONAL COPYRIGHTED MATERIAL

HI-STORM FSAR
REPORT HI-2002444

8.3-7

Rev. 12

closely controlled to insure that the internal pressure in the MPC does not exceed design limits. The water flow rate shall be adjusted to maintain the internal pressure below design limits.

- i. Prepare the MPC fill and vent lines as shown on Figure 8.1.20. Route the vent port line several feet below the spent fuel pool surface or to the radwaste gas facility. Attach the vent line to the MPC vent port and slowly open the vent line valve to depressurize the MPC.

Note:

When unloading MPCs requiring soluble boron, the boron concentration of the water shall be checked in accordance with Tables 2.1.14 and 2.1.16 before and during operations with fuel and water in the MPC.

- j. Attach the water fill line to the MPC drain port and slowly open the water supply valve and establish a pressure less than 90 psi. (Refer to Tables 2.1.14 and 2.1.16 for boron concentration requirements). Fill the MPC until bubbling from the vent line has terminated. Close the water supply valve on completion.
- k. If used, cease operation of the SCS and remove the system from the HI-TRAC.

Caution:

Combustible gas monitoring as described this Caution block is required by the HI-STORM 100 CoC (CoC Appendix B and B-100U, Section 3.8) and may not be deleted without prior NRC approval via CoC amendment. Oxidation of neutron absorber panels contained in the MPC may create hydrogen gas while the MPC is filled with water. Appropriate monitoring for combustible gas concentrations shall be performed prior to, and during MPC lid cutting operations. The space below the MPC lid shall be purged with inert gas prior to, and during MPC lid cutting operations to provide additional assurance that flammable gas concentrations will not develop in this space.

- l. Disconnect both lines from the drain and vent ports leaving the drain port cap open to allow for thermal expansion of the water during MPC lid weld removal.
- m. Connect a combustible gas monitor to the MPC vent port and check for combustible gas concentrations prior to and periodically during weld removal activities. Purge the gas space under the lid as necessary.
- n. Remove the MPC lid-to-shell weld using the weld removal system. See Figure 8.1.9 for rigging.
- o. Vacuum the top surfaces of the MPC and HI-TRAC to remove any metal shavings.

9. Install the inflatable annulus seal as follows:

HOLTEC INTERNATIONAL COPYRIGHTED MATERIAL

HI-STORM FSAR
REPORT HI-2002444

8.3-8

Rev. 12

Caution:

Do not use any sharp tools or instruments to install the inflatable seal.

- a. Remove the annulus shield.
 - b. Manually insert the inflatable seal around the MPC. See Figure 8.1.13.
 - c. Ensure that the seal is uniformly positioned in the annulus area.
 - d. Inflate the seal
 - e. Visually inspect the seal to ensure that it is properly seated in the annulus. Deflate, adjust and inflate the seal as necessary.
10. Place HI-TRAC in the spent fuel pool as follows:
- a. If necessary for plant weight limitations, drain the water from the neutron shield jacket.
 - b. Engage the lift yoke to HI-TRAC lifting trunnions, remove the MPC lid lifting hole plugs and attach the MPC lid slings or lid retention system to the MPC lid.
 - c. If the lid retention system is used, inspect the lid bolts for general condition. Replace worn or damaged bolts with new bolts.
 - d. Install the lid retention system bolts if the lid retention system is used.

ALARA Note:

The optional Annulus Overpressure System is used to provide further protection against MPC external shell contamination during in-pool operations.

- e. If used, fill the annulus overpressure system lines and reservoir with demineralized water and close the reservoir valve. Attach the annulus overpressure system to the HI-TRAC. See Figure 8.1.14.
- f. Position HI-TRAC over the cask loading area with the basket aligned to the orientation of the spent fuel racks.

ALARA Note:

Wetting the components that enter the spent fuel pool may reduce the amount of decontamination work to be performed later.

- g. Wet the surfaces of HI-TRAC and lift yoke with plant demineralized water while slowly lowering HI-TRAC into the spent fuel pool.
- h. When the top of the HI-TRAC reaches the elevation of the reservoir, open the annulus overpressure system reservoir valve. Maintain the reservoir water level at approximately 3/4 full the entire time the cask is in the spent fuel pool.
- i. If the lid retention system is used, remove the lid retention bolts when the top of HI-TRAC is accessible from the operating floor.

HOLTEC INTERNATIONAL COPYRIGHTED MATERIAL

- j. Place HI-TRAC on the floor of the cask loading area and disengage the lift yoke. Visually verify that the lift yoke is fully disengaged.
- k. Apply slight tension to the lift yoke and visually verify proper disengagement of the lift yoke from the trunnions.
- l. Remove the lift yoke, MPC lid and drain line from the pool in accordance with directions from the site's Radiation Protection personnel. Spray the equipment with demineralized water as they are removed from the pool.
- m. Disconnect the drain line from the MPC lid.
- n. Store the MPC lid components in an approved location. Disengage the lift yoke from MPC lid. Remove any upper fuel spacers using the same process as was used in the installation.
- o. Disconnect the lid retention system if used.

8.3.4 MPC Unloading

- 1. Remove the spent fuel assemblies from the MPC using applicable site procedures.
- 2. Vacuum the cells of the MPC to remove any debris or corrosion products.
- 3. Inspect the open cells for presence of any remaining items. Remove them as appropriate.

8.3.5 Post-Unloading Operations

- 1. Remove HI-TRAC and the unloaded MPC from the spent fuel pool as follows:
 - a. Engage the lift yoke to the top trunnions.
 - b. Apply slight tension to the lift yoke and visually verify proper engagement of the lift yoke to the trunnions.
 - c. Raise HI-TRAC until HI-TRAC flange is at the surface of the spent fuel pool.

ALARA Warning:
Activated debris may have settled on the top face of HI-TRAC during fuel unloading.

- d. Measure the dose rates at the top of HI-TRAC in accordance with plant radiological procedures and flush or wash the top surfaces to remove any highly-radioactive particles.
- e. Raise the top of HI-TRAC and MPC to the level of the spent fuel pool deck.
- f. Close the annulus overpressure system reservoir valve.
- g. Using a water pump, lower the water level in the MPC approximately 12 inches to prevent splashing during cask movement.

ALARA Note:

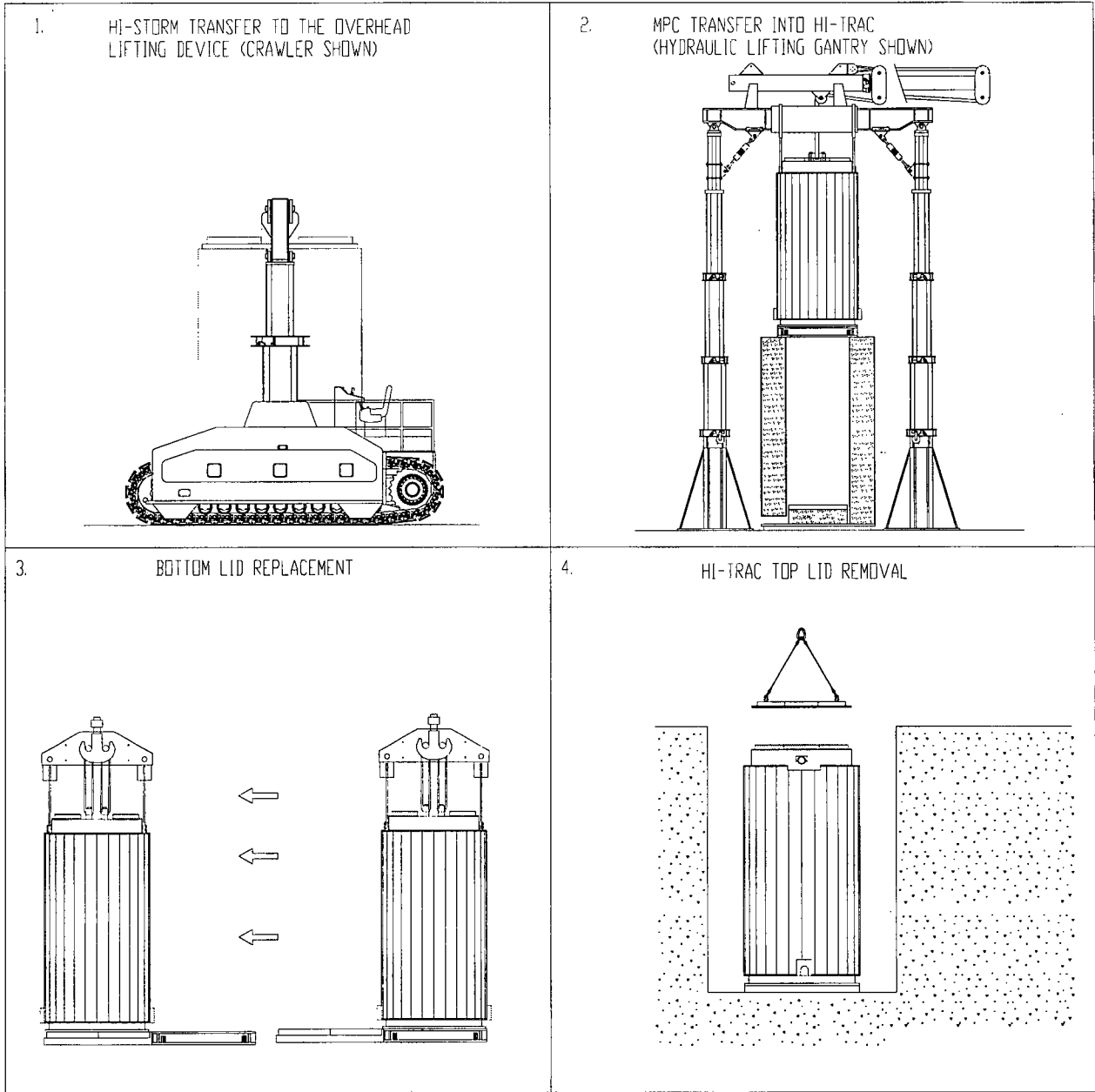
To reduce contamination of HI-TRAC, the surfaces of HI-TRAC and lift yoke should be kept wet until decontamination can begin.

- h. Remove HI-TRAC from the spent fuel pool while spraying the surfaces with plant demineralized water.
 - i. Disconnect the annulus overpressure system from the HI-TRAC via the quick disconnect.
 - j. Place HI-TRAC in the designated preparation area.
 - k. Disengage the lift yoke.
 - l. Perform decontamination on HI-TRAC and the lift yoke.
2. Carefully decontaminate the area above the inflatable seal. Deflate, remove, and store the seal in an approved plant storage location.
3. Using a water pump, pump the remaining water in the MPC to the spent fuel pool or liquid radwaste system.
4. Drain the water in the annulus area by connecting the drain line to the HI-TRAC drain connector.
5. Remove the MPC from HI-TRAC and decontaminate the MPC as necessary.
6. Decontaminate HI-TRAC.
7. Remove the bolt plugs and/or waterproof tape from HI-TRAC top bolt holes.
8. Return any HI-STORM 100 equipment to storage as necessary.

LOCATION: ISFSI
RECOVER HI-STORM FROM STORAGE
LOCATION: CASK RECEIVING AREA
REMOVE HI-STORM EXIT VENT SCREENS AND CROSS PLATES
REMOVE HI-STORM LID
INSTALL HI-STORM ALIGNMENT DEVICE (OR MATING DEVICE) AND VENT DUCT SHIELD INSERTS
INSTALL MPC LIFT CLEATS
ATTACH MPC SLINGS
INSTALL TOP LID ON HI-TRAC
INSTALL MPC LIFT SLINGS
RAISE HI-TRAC AND MATE OVERPACKS
OPEN SHIELD DOORS (OR MATING DEVICE DRAWER)
ATTACH SLINGS TO LIFT DEVICE AND CLEAT
RAISE MPC INTO HI-TRAC
CLOSE HI-TRAC TRANSFER LID DOORS (HI-TRAC 100D and 125D - BOLT UP POOL LID)
REMOVE HI-TRAC FROM TOP OF HI-STORM
DISCONNECT MPC LIFT SLINGS
REPLACE TRANSFER LID WITH POOL LID (NOT FOR HI-TRAC 100D and 125D)
DISCONNECT MPC LIFT CLEAT
PLACE HI-TRAC IN DESIGNATED PREPARATION AREA
LOCATION: CASK PREPARATION AREA

REMOVE HI-TRAC TOP LID
FILL ANNULUS
INSTALL ANNULUS SHIELD
REMOVE MPC CLOSURE RING
REMOVE VENT PORT COVERPLATE WELD AND SAMPLE MPC GAS
FILL MPC CAVITY WITH WATER
REMOVE MPC LID TO SHELL WELD
INSTALL INFLATABLE SEAL
PLACE HI-TRAC IN SPENT FUEL POOL
LOCATION: SPENT FUEL POOL
REMOVE MPC LID
DISCONNECT DRAIN LINE
REMOVE SPENT FUEL ASSEMBLIES WASTE FROM MPC
VACUUM CELLS OF MPC
REMOVE HI-TRAC FROM SPENT FUEL POOL
LOCATION: CASK PREPARATION AREA
LOWER WATER LEVEL IN MPC
PUMP REMAINING WATER IN MPC TO SPENT FUEL POOL
REMOVE MPC FROM HI-TRAC
DECONTAMINATE HI-TRAC

Figure 8.3.1; Unloading Operations Flow Diagram



Note: Bottom Lid Replacement Not Required for HI-TRAC 100D and 125D

Figure 8.3.2a; Major HI-STORM 100 Unloading Operations

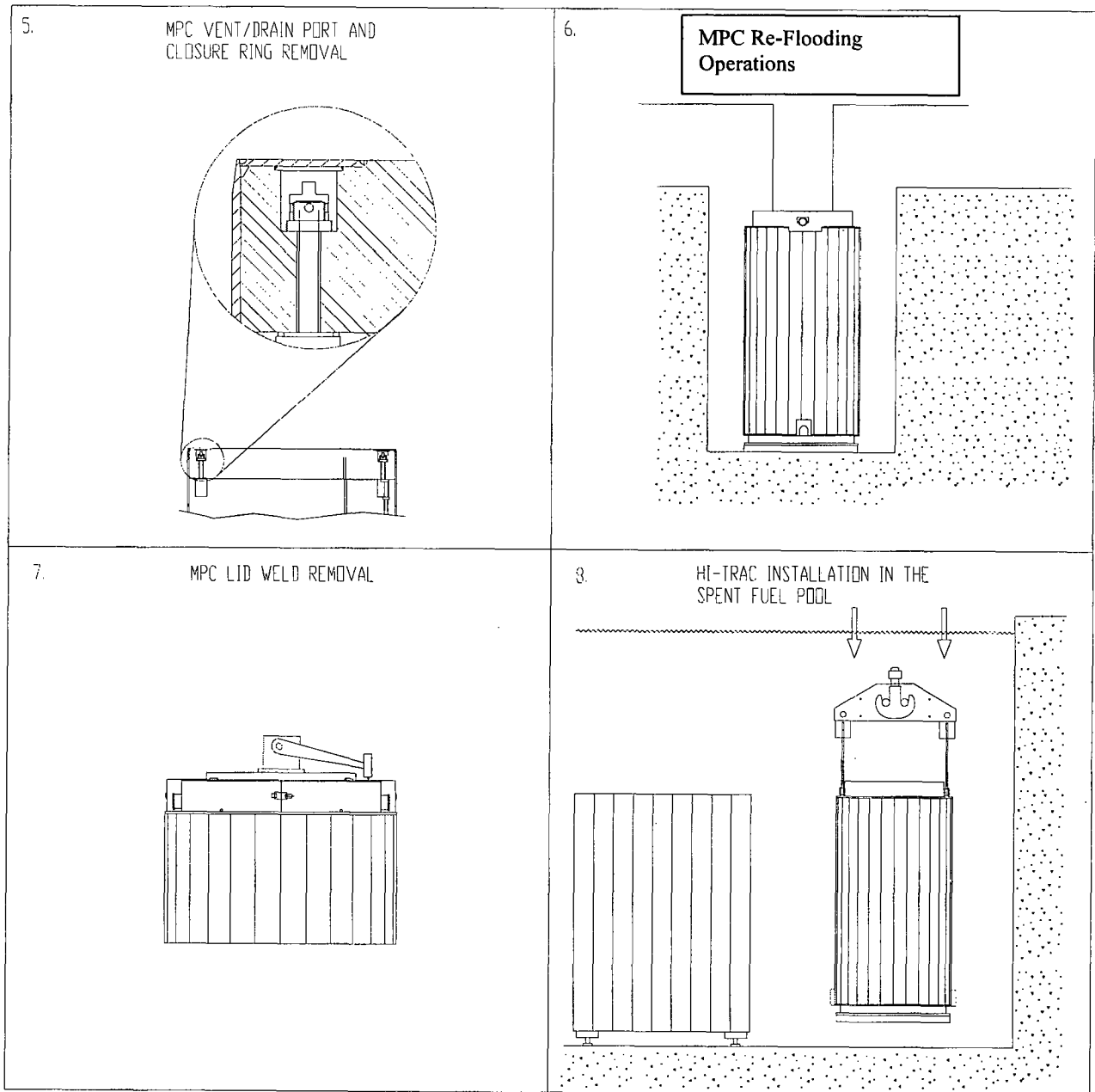


Figure 8.3.2b; Major HI-STORM 100 Unloading Operations

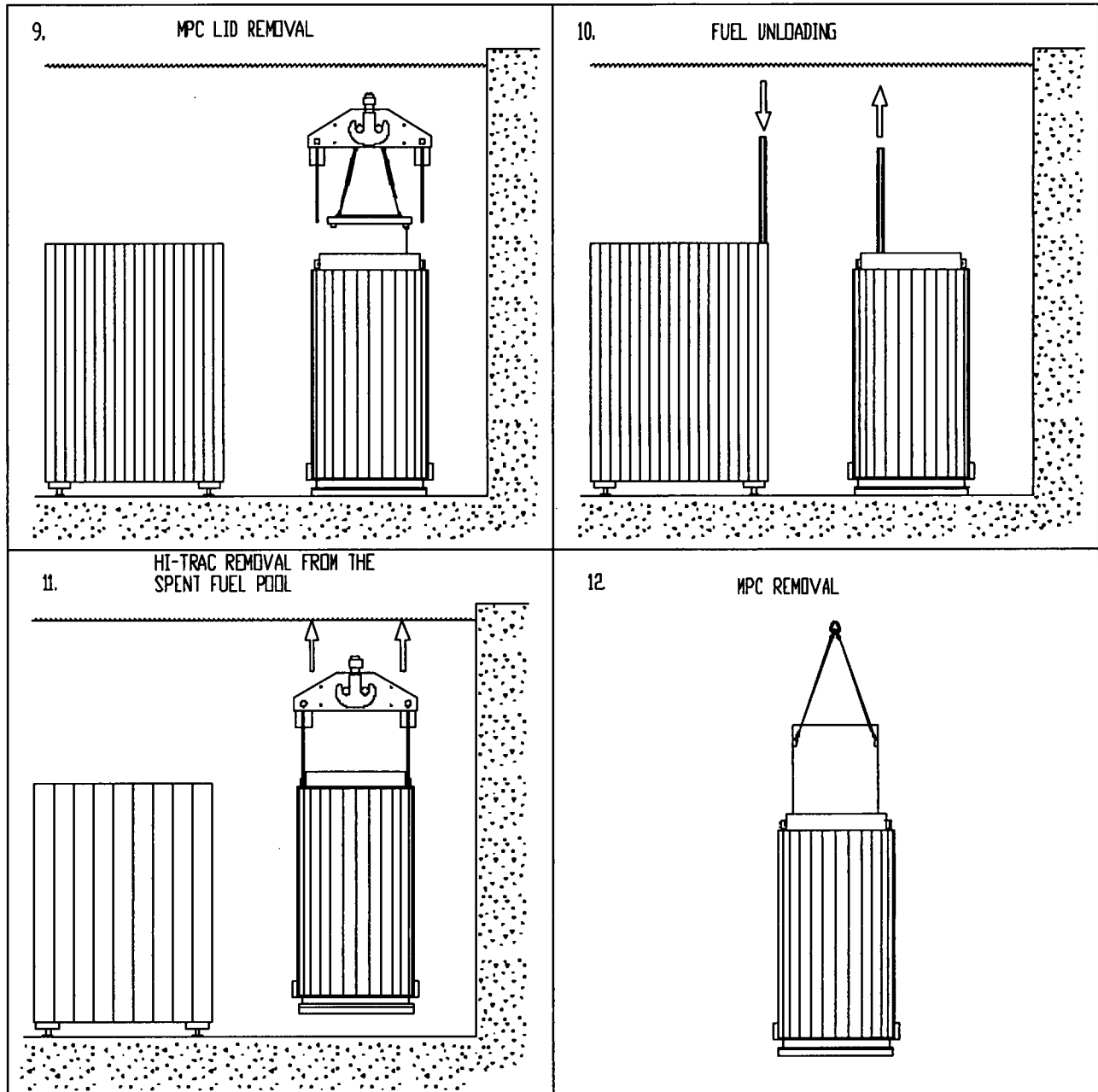


Figure 8.3.2c; Major HI-STORM 100 Unloading Operations

13. MPC AND HI-TRAC DECONTAMINATION

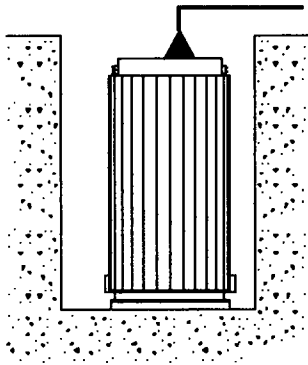


Figure 8.3.2d; Major HI-STORM 100 Unloading Operations

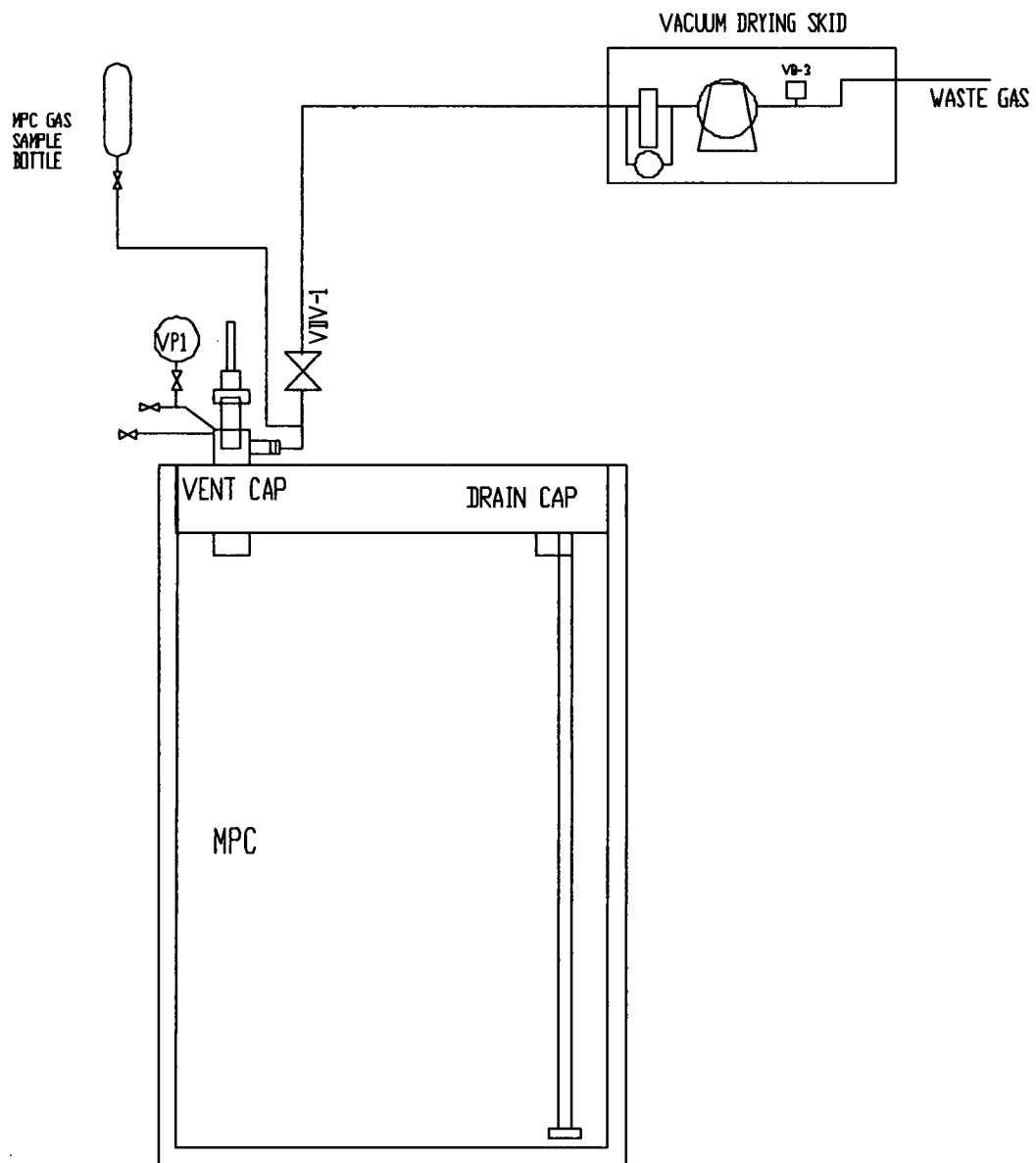


Figure 8.3.3; MPC Gas Sampling in Preparation for Unloading

Figure 8.3.4; Deleted

8.4 MPC TRANSFER TO A HI-STAR 100 OVERPACK FOR TRANSPORT OR STORAGE

8.4.1 Overview of Operations

The MPC is recovered from storage and transferred into HI-TRAC using the same or similar method as described in Section 8.3. Once the MPC is inside HI-TRAC, the HI-STAR 100 is brought to the transfer location and positioned for receiving of the MPC. If used, the Temporary Shield Ring is installed and filled with water and the Transfer Collar is installed on the HI-STAR 100 Overpack. The Temporary Shield Ring reduces operator dose rates during MPC transfer operations. The Transfer Collar or mating device adapts the top surface of the HI-STAR 100 Overpack to mate with the bottom of HI-TRAC. The MPC may be lowered using the MPC Downloader, the main crane hook or similar device. The MPC slings and MPC lift cleats are attached to the MPC. The MPC is raised slightly, the transfer lid door (or mating device drawer) locking pins are removed and the doors are (drawer is) opened. The MPC is lowered into the HI-STAR. Following verification that the MPC is fully lowered, the MPC slings are disconnected and lowered onto the MPC lid. HI-TRAC is removed from on top of the HI-STAR 100 Overpack. The MPC lift cleat, slings, and the transfer collar/mating device are removed. Hole plugs are installed in the empty MPC lid bolt holes. The HI-STAR 100 Overpack is prepared for storage or transport in accordance with the Certificate of Compliance for storage or transport, as applicable.

8.4.2 Recovery from Storage

Caution:

Limitations for the handling an MPC containing high burn-up fuel in a HI-TRAC are evaluated and established on a canister basis to ensure that acceptable cladding temperatures are not exceeded. Refer to FSAR Section 4.5 for guidance.

1. Recover the MPC from storage and position it inside of HI-TRAC in accordance with Section 8.3.2.
2. Deleted.

8.4.3 MPC Transfer into the HI-STAR 100 Overpack

Note:

The following steps outline the HI-STAR 100 operating steps. Refer to the HI-STAR 100 System Final Safety Analysis Report (Docket No. 72-1008) and the HI-STAR 100 System Safety Analysis Report (Docket No. 71-9261) for HI-STAR 100 Overpack specific operations.

HOLTEC INTERNATIONAL COPYRIGHTED MATERIAL

1. If necessary, remove the HI-STAR 100 closure plate and the removable shear ring segments. Perform a radiological survey of the inside of the HI-STAR 100 Overpack to verify there is no residual contamination from previous uses. If contamination levels are above specified limits, the HI-STAR 100 Overpack shall be decontaminated appropriately prior to use.
2. Discard any used metallic seals.
3. Perform a HI-STAR 100 receipt inspection in accordance with site-specific procedures.
4. Install the temporary shield ring on HI-STAR 100 and fill it with water, if used. See Figure 8.1.18.
5. Install the HI-STAR transfer collar (or mating device with the pool lid for HI-TRAC 100D and 125D). See Figure 8.4.1a (or Figure 8.4.1b).
6. Position HI-STAR adjacent to HI-TRAC.

Note:

Lifting of the loaded HI-TRAC shall be performed in accordance with the applicable lifting requirements.

7. Raise and align HI-TRAC over HI-STAR and mate the overpacks.

Note:

The MPC lift cleats and MPC slings are still installed from the previous operation.

8. Deleted.
9. Remove the transfer lid door (mating device drawer) locking pins and open the doors (drawer).

ALARA Warning:

If trim plates are not used, personnel should remain clear of the immediate door/drawer area during MPC downloading since there may be radiation streaming during MPC raising and lowering operations.

10. At the user's discretion, install trim plates to cover the gap above and below the door/drawer. The trim plates may be secured using hand clamps or any other method deemed suitable by the user. See Figure 8.1.33.
11. Lower the MPC into HI-STAR.
12. When the MPC is fully seated, disconnect the slings from the MPC lifting device and lower them on to the MPC lid.
13. Remove HI-TRAC from on top of HI-STAR 100 Overpack.
14. Remove the MPC lift cleat from the MPC and install hole plugs in the empty bolt holes. See Table 8.1.5 for torque requirements.
15. Remove the HI-STAR 100 transfer collar or mating device.

16. Drain and remove the temporary shield ring (if used) and store it in an approved plant storage location.
17. Complete HI-STAR preparation for transport in accordance with the HI-STAR 100 Safety Analysis Report (Docket 71-9261) and the Certificate of Compliance, or complete HI-STAR preparation for storage in accordance with the HI-STAR 100 Final Safety Analysis Report (Docket 72-1008) and the Certificate of Compliance, as applicable.

HOLTEC INTERNATIONAL COPYRIGHTED MATERIAL

HI-STORM FSAR
REPORT HI-2002444

8.4-3

Rev. 4

HI-STORM 100 FSAR; NON-PROPRIETARY
REVISION 12
MARCH 12, 2014

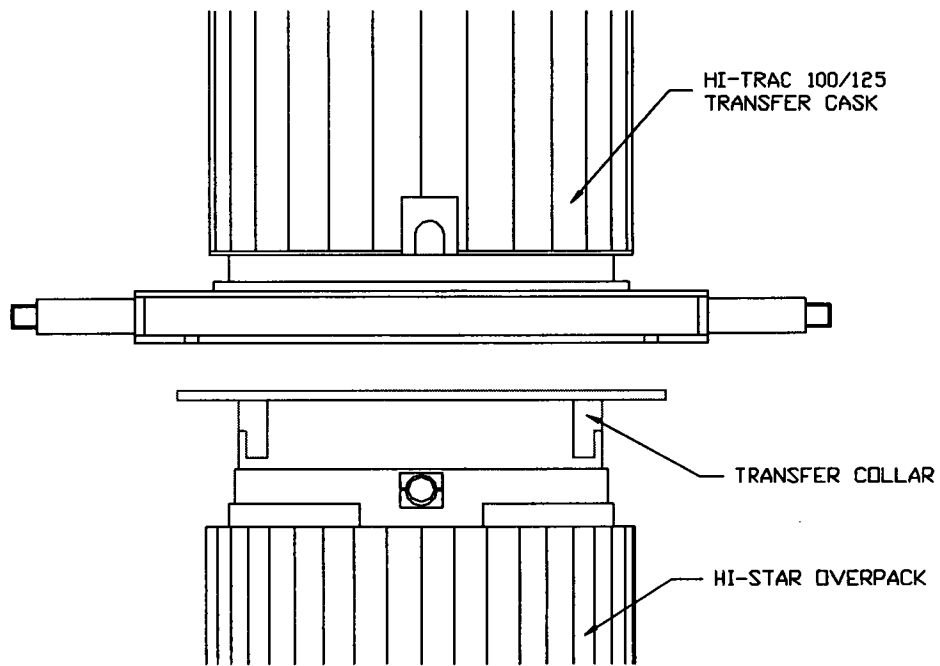


Figure 8.4.1a; HI-STAR and HI-TRAC Mating

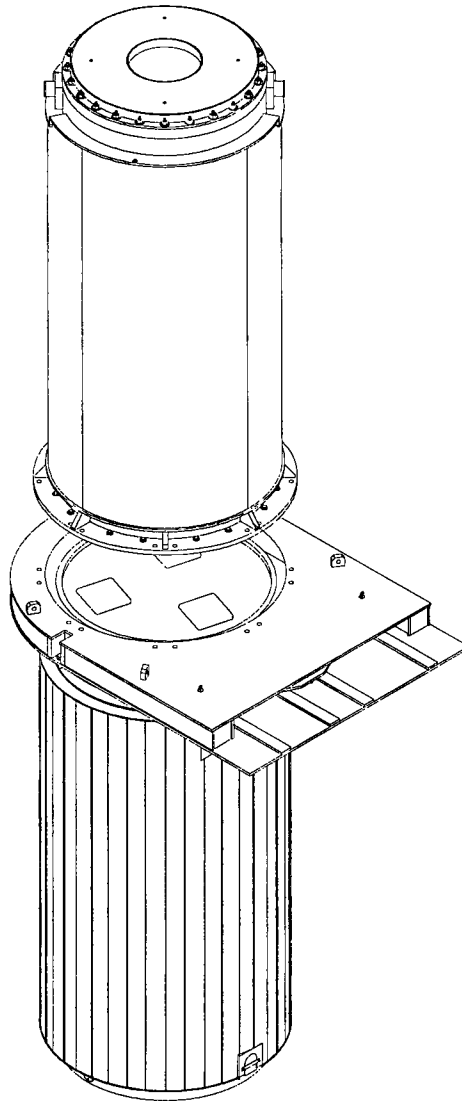


Figure 8.4.1b; HI-STAR and HI-TRAC 100D/125D Mating

8.5 MPC TRANSFER INTO THE HI-STORM 100 OVERPACK DIRECTLY FROM TRANSPORT

8.5.1 Overview of Operations

HI-STAR 100 Dual-Purpose Cask System arrives at the receiving location and is surveyed for dose rates and contamination levels. The receiver reviews the shipping paperwork to ensure that the HI-STAR 100 Overpack met the internal contamination limits prior to transportation. The personnel barrier is removed, the impact limiters are removed, the tie-down is removed, and the HI-STAR 100 Overpack is upended. The HI-STAR 100 Overpack is positioned at the designated transfer area and the temporary shield ring is installed. The temporary shield ring reduces operator dose rates during MPC transfer operations. A gas sample is drawn from the annulus and analyzed. The gas sample provides an indication of MPC closure performance. The annulus is depressurized and the closure plate is removed. The transfer collar (mating device with pool lid for HI-TRAC 100 D and 125D) is installed and the MPC lift cleats are attached to the MPC. The transfer collar (mating device) is used to provide the mating surface on top of the HI-STAR 100 Overpack. The MPC slings are attached to the MPC lift cleat.

If the HI-TRAC 100D and 125D are not used, the HI-TRAC is configured with the transfer lid. The top lid¹ is installed, if necessary. HI-TRAC is raised and positioned on top of HI-STAR. The MPC slings are attached to the lifting device. The MPC is raised into HI-TRAC. The HI-TRAC doors/(mating device drawer) are closed and the locking pins are installed. For the HI-TRAC 100D and 125D, the pool lid is bolted on. HI-TRAC is raised and the HI-STAR 100 Overpack is removed from under HI-TRAC. The HI-STAR 100 Overpack is repositioned at the user's discretion.

HI-STORM is positioned for MPC receipt with the lid removed, the *alignment device (or mating device) positioned*, and the vent duct shield inserts installed in the exit vent ducts. HI-TRAC is raised and positioned on top of HI-STORM. For HI-TRAC 100D and 125D, the pool lid is unbolted. The locking pins are removed and the doors are opened (or mating device drawer opened for HI-TRAC 100D and 125D). The MPC is lowered into HI-STORM. The MPC slings are disconnected and lowered onto the MPC lid. HI-TRAC is raised and positioned at the site's discretion. The MPC lift cleat, slings, vent duct shield inserts, and transfer collar (or mating device) are removed and hole plugs are installed in the empty bolt holes. HI-STORM is prepared for storage and transferred to the ISFSI pad in the same manner as described in Section 8.1.

¹ Users with the optional HI-TRAC Lid Spacer shall modify steps in their procedures to install and remove the spacer together with top lid.

8.5.2 HI-STAR 100 SYSTEM Receipt and Preparation for MPC Transfer

Note:

The following provides a general description of the HI-STAR 100 System operations. Refer to the HI-STAR 100 System Topical Safety Analysis Report (Docket 72-1008) and the Safety Analysis Report (Docket 71-9261) for HI-STAR-specific operations.

1. Review the shipping paperwork and verify that the HI-STAR 100 Overpack met the required internal contamination limits prior to transportation.
2. Measure the HI-STAR 100 dose rates in accordance with 10CFR20 [8.5.1].
3. Remove the personnel barrier.
4. Perform removable contamination surveys in accordance with 10CFR20 [8.5.1].
5. Remove the impact limiters.
6. Remove the tie-down.
7. Perform a visual inspection of the overpack for obvious signs of shipping damage.
8. Remove the removable shear ring segments from the overpack. (Approximate weight is 50 lbs each).
9. Transfer the HI-STAR 100 Overpack to the location for MPC transfer and position it vertically.
10. Install the temporary shield ring on the overpack top flange if used.

ALARA Warning:

Gas sampling is performed to assess the condition of the MPC confinement boundary. If a leak is discovered in the MPC boundary, the MPC may not be placed into HI-STORM. If no leak is detected, the annulus may be vented directly.

11. Perform gas sampling as follows:
 - a. Remove the overpack vent port cover plate and attach the backfill tool with a sample bottle attached. See Figure 8.5.1. Store the cover plate in a site-approved location.
 - b. Using a vacuum pump, evacuate the sample bottle and backfill tool.

HOLTEC INTERNATIONAL COPYRIGHTED MATERIAL

- c. Slowly open the vent port plug and gather a gas sample from the annulus. Reinstall the overpack vent port plug.
 - d. Evaluate the gas sample and determine the condition of the MPC confinement boundary.
12. If the confinement boundary is intact (i.e., no radioactive gas is measured) then vent the overpack annulus by removing the overpack vent port seal plug (using the backfill tool). Otherwise return the HI-STAR 100 to the spent fuel pool for MPC unloading in accordance with the HI-STAR 100 SAR.
 13. Remove the closure plate bolts and remove the overpack closure plate. Store the closure plate on cribbing to protect the seal seating surfaces. Store the closure plate bolts in a site-approved location.
 14. Install the HI-STAR 100 Seal Surface Protector.
 15. Install the transfer collar (or mating device with pool lid for HI-TRAC 100D and 125D) on HI-STAR. See Figure 8.4.1.

Note:

The location of MPC transfer may be selected at the user's discretion.

16. Remove the MPC lift cleat hole plugs and install the MPC lift cleats. See Figure 8.1.24. See Table 8.1.5 for torque requirements.
17. Attach the MPC slings to the MPC lift cleat and lay them on the MPC lid.

Warning:

Unless the lift is single-failure proof (or equivalent safety factor) for the HI-TRAC top lid, the lid shall be kept less than 2 feet above the top surface of the MPC. This is performed to protect the MPC lid from a potential lid drop.

18. If necessary, install the HI-TRAC top lid. See Figure 8.1.9. See Table 8.1.5 for torque requirements.
19. If necessary, configure HI-TRAC with the transfer lid as follows (Not applicable for HI-TRAC 100D and 125D):

ALARA Note:

The bottom lid replacement as described below may be performed only on an empty HI-TRAC.

- a. Position HI-TRAC vertically adjacent to the transfer lid.

HOLTEC INTERNATIONAL COPYRIGHTED MATERIAL

- b. Remove the pool lid bolts and plates and store them in an approved plant storage location.
 - c. Raise the empty HI-TRAC and position it on top of the transfer lid.
 - d. Install the bottom lid bolts. See Table 8.1.5 for torque requirements.
20. Position HI-TRAC adjacent to HI-STAR.
 21. Raise HI-TRAC above HI-STAR.
 22. Align HI-TRAC over HI-STAR 100 and mate the overpacks. See Figure 8.1.31.
 23. Remove the locking pins and open the doors or mating device drawer.

ALARA Warning:

If trim plates are not being used, personnel should remain clear of the door/drawer area during MPC downloading since there may be some radiation streaming during MPC raising and lowering operations.

24. At the users discretion, install trim plates to cover the gap above and below the door/drawer. The trim plates may be secured using clamps or any other method deemed suitable by the user. See Figure 8.1.33.

8.5.3 Perform MPC Transfer into HI-STORM 100

Caution:

Limitations for the handling an MPC containing high burn-up fuel in a HI-TRAC are evaluated and established on a canister basis to ensure that acceptable cladding temperatures are not exceeded. Refer to FSAR Section 4.5 for guidance.

1. Raise the MPC into HI-TRAC by extending the MPC downloader.
2. Verify the MPC is in the full-up position.
3. Remove the trim plates (if used).
4. Close the HI-TRAC doors/drawer and install the locking pins.
5. For the HI-TRAC 100D and 125D, raise the pool lid and bolt it onto the HI-TRAC.
6. Raise HI-TRAC and remove the HI-STAR 100 Overpack from the operations area.

HOLTEC INTERNATIONAL COPYRIGHTED MATERIAL

HI-STORM FSAR
REPORT HI-2002444

8.5-4

Rev. 7

7. Transfer the MPC into HI-STORM in accordance with the steps provided in Section 8.1.

Warning:

HI-STORM dose rates are measured to ensure they are within expected values. Dose rates exceeding the expected values could indicate that fuel assemblies not meeting the CoC may have been loaded.

8. Perform the HI-STORM surface dose rate measurements in accordance with the technical specifications. Measured dose rates must be compared with calculated dose rates that are consistent with the calculated doses that demonstrate compliance with the dose limits of 10 CFR 72.104(a).
9. Place HI-STORM in storage in accordance with the steps provided in Section 8.1.
10. Perform an air temperature rise test per Step 8.1.7.23 if required.

HOLTEC INTERNATIONAL COPYRIGHTED MATERIAL

HI-STORM FSAR
REPORT HI-2002444

8.5-5

Rev. 7

HI-STORM 100 FSAR, NON-PROPRIETARY
REVISION 12
MARCH 12, 2014

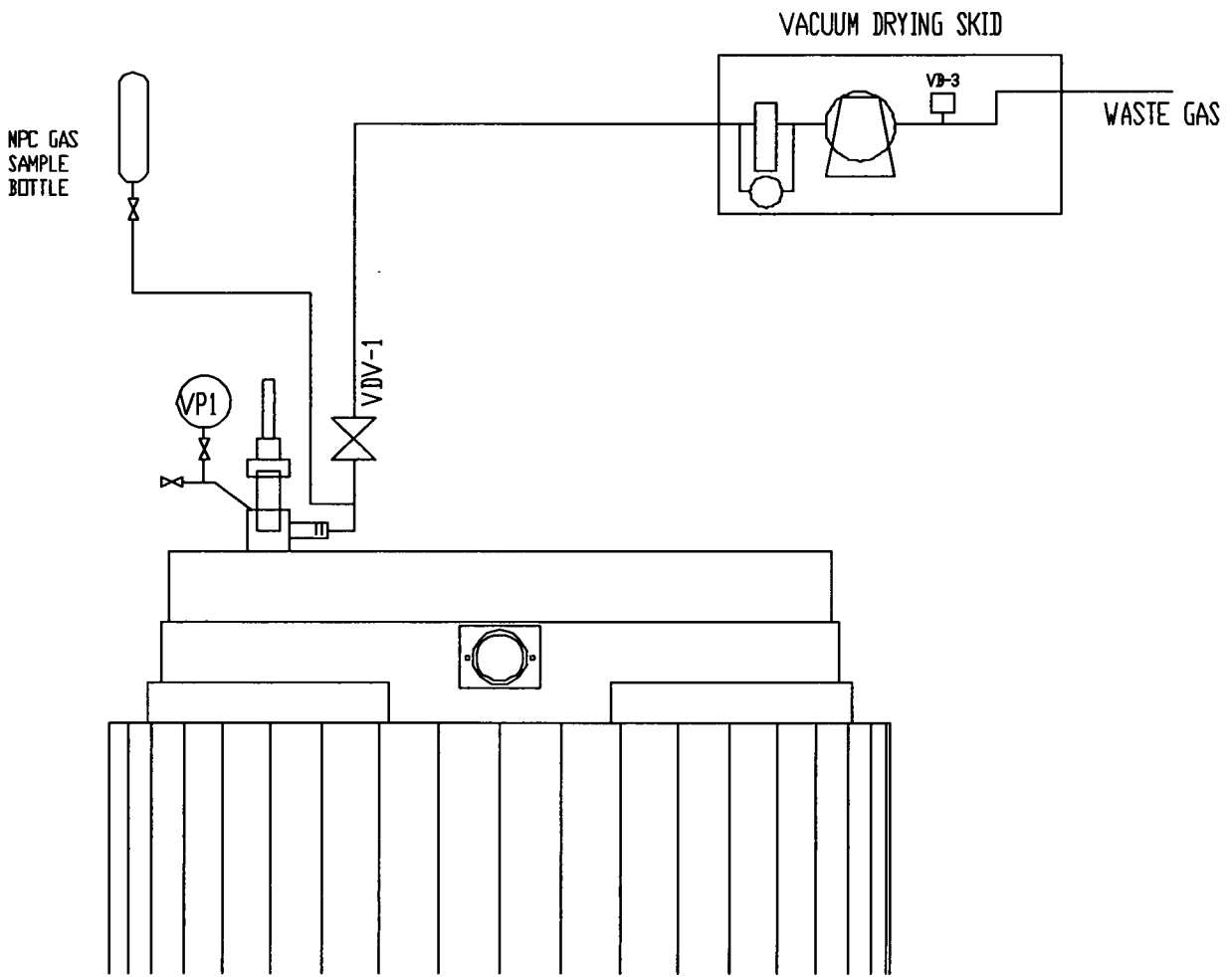


Figure 8.5.1; HI-STAR Annulus Gas Sampling

8.6 REFERENCES

- [8.0.1] U.S. Nuclear Regulatory Commission, "Standard Review Plan for Dry Cask Storage Systems", NUREG-1536, Final Report, January 1997.
- [8.1.1] U.S. Code of Federal Regulations, Title 10 "Energy", Part 72, "Licensing Requirements for Independent Storage of Spent Nuclear Fuel and High-Level Radioactive Waste,"
- [8.1.2] American National Standards Institute, Institute for Nuclear Materials Management, "American National Standard for Radioactive Materials – Leakage Tests on Packages for Shipment," ANSI N14.5-1997.
- [8.1.3] American Society of Mechanical Engineers "Boiler and Pressure Vessel Code".
- [8.5.1] U.S. Code of Federal Regulations, Title 10 " Energy", Part 20, "Standards for Protection Against Radiation,"

HOLTEC INTERNATIONAL COPYRIGHTED MATERIAL

HI-STORM FSAR
REPORT HI-2002444

8.6-1

Rev. 1

HI-STORM 100 FSAR, NON-PROPRIETARY
REVISION 12
MARCH 12, 2014

SUPPLEMENT 8.I

OPERATING PROCEDURES FOR THE HI-STORM 100U SYSTEM

8.I.0 INTRODUCTION

The operations associated with the use of the HI-STORM 100U System, described in Supplement I.I, are quite similar to the operations for all other variations of the HI-STORM 100 System. The following sections describe those operations that are, in any respect, unique to the HI-STORM 100U System and thus supplement the information presented in Chapter 8. Where practical, the section number used below directly references the corresponding section in Chapter 8. For example, Subsection 8.I.1.6 supplements or replaces the operations described in Subsection 8.1.6. The guidance provided in this supplement shall be used to develop the site-specific loading procedures for the HI-STORM 100U System, as described in the main body of Chapter 8.

8.I.1 PROCEDURE FOR LOADING THE HI-STORM 100U SYSTEM IN THE SPENT FUEL POOL

8.I.1.1 Overview of Loading Operations

The HI-STORM 100U System differs from the other variations of the HI-STORM 100 System in that the vertical ventilated module (VVM) is an integral part of the ISFSI and cannot be transported on site. The steps required to prepare and load the HI-STORM 100 System up to the point of MPC transfer to the HI-STORM VVM are described in Sections 8.1.2 to 8.1.5 of Chapter 8. For the HI-STORM 100U System, the MPC transfer is performed at the ISFSI after preparation of the MPC for storage operations within the HI-TRAC transfer cask. The loaded HI-TRAC transfer cask may be transported between the ISFSI and the fuel loading facility using a specially designed transporter, heavy haul transfer trailer, or other load handling equipment designed for such applications. The operational steps required to prepare, load the MPC, and transport it to the ISFSI using the HI-TRAC transfer cask are the same for both HI-STORM 100U and the aboveground HI-STORM for the case wherein the MPC transfer for long-term storage occurs at the ISFSI. The detailed operational steps presented in this supplement, therefore, start with the preparation and loading at the ISFSI.

Prior to MPC transfer at the ISFSI, the VVM lid is removed and the empty storage module is inspected. The mating device is positioned on top of the VVM. If used, the Supplemental Cooling System (SCS) is disconnected from the HI-TRAC, the HI-TRAC annulus is drained and the HI-TRAC transfer cask is placed on top of the mating device (Figure 8.I.1). The MPC may be downloaded using the vertical cask crawler, the MPC downloader attached to the transfer cask, or other suitable lifting device. The MPC lifting device is attached to the MPC. The pool lid is removed and the mating device drawer is opened. Optional temporary shielding may be installed, as guided by the licensee's radiation protection program, on or around the mating device. The MPC is lowered into the VVM (Figure 8.I.2). Following verification that the MPC is fully lowered, the MPC slings are disconnected from the lifting device and lowered onto or

HOLTEC INTERNATIONAL COPYRIGHTED MATERIAL

removed from the MPC lid. The temporary shielding is removed, if necessary. The HI-TRAC and pool lid may be reattached while on the VVM or may be removed and then reattached. HI-TRAC is removed from on top of the VVM. The MPC lift cleats are removed. Plugs are installed in the empty MPC lifting holes to fill the voids left by the removal of the lift cleat studs. The mating device is removed and the VVM lid is installed. Finally, the temperature monitoring elements and their instrument connections, if used at the ISFSI, are installed, and post-loading performance verification is performed, as required.

8.1.1.2 HI-STORM 100U Receiving Operations

Because the HI-STORM 100U VVM is cast as part of the ISFSI itself, there is no handling of the VVM. For an example of the rigging required to handle the HI-STORM 100U VVM Closure Lid, see Figure 8.I.3.

8.1.1.3 HI-TRAC and MPC Receipt Inspection and Loading Preparation

For the HI-STORM 100U System, these activities are identical to those described in Subsection 8.1.3.

8.1.1.4 MPC Fuel Loading

For the HI-STORM 100U System, these activities are identical to those described in Subsection 8.1.4.

8.1.1.5 MPC Closure

For the HI-STORM 100U System, these activities are identical to those described in Subsection 8.1.5.

8.1.1.6 Preparation for Storage

For the HI-STORM 100U System, these activities are essentially identical to those described in Subsection 8.1.6. However, for the HI-STORM 100U VVM, the receipt and cleanliness inspection should be carried out in accordance with a CoC Holder-approved inspection checklist and Table 8.I.1

8.1.1.7 Placement of MPC/HI-STORM 100U VVM into Storage

Note:

Because the HI-STORM 100U VVM is an integral part of the ISFSI, MPC transfer must take place at the ISFSI.

HOLTEC INTERNATIONAL COPYRIGHTED MATERIAL

1. Perform a transport route walkdown to ensure that the cask transport conditions are met.
2. Remove the outlet vent cover if necessary. Remove the VVM lid. See Figure 8.I.3 for a lid rigging example and Subsection 3.I.2 for the bounding weight of the lid.
3. Inspect all vent and cavity locations in the VVM cavity for foreign objects. Remove any foreign objects.
4. Install the mating device on the VVM.
5. Transport the HI-TRAC transfer cask to the ISFSI location using a vertical cask crawler or other suitable transportation device.

Caution:

For MPCs with heat loads requiring supplemental cooling, all preparatory work related to the transfer should be completed prior to terminating supplemental cooling operations to prevent fuel cladding temperatures from exceeding the limits set forth in Chapter 2 of this FSAR.

6. If used, discontinue the supplemental cooling operations and disconnect the SCS. Drain the water from the HI-TRAC annulus to an appropriate plant discharge point.
7. Position the HI-TRAC transfer cask above the VVM.
8. Align HI-TRAC over the VVM and mate the casks using the mating device. See Figure 8.I.1.
9. Attach the MPC slings to the MPC lift cleats and the cask transporter or other suitable downloading device. See Figure 8.I.2.
10. Raise the MPC slightly to remove the weight of the MPC from the HI-TRAC pool lid.
11. Unbolt the pool lid from the HI-TRAC and lower the lid into the mating device.
12. Open the mating device drawer.

ALARA Warning:

Temporary shielding may be used to reduce personnel dose during transfer operations. If ALARA considerations dictate that temporary shielding not be used, personnel must remain clear of the immediate area around the mating device drawer during MPC downloading.

13. At the user's discretion, install temporary shielding to cover the gap above and below the mating device drawer.
14. Lower the MPC into the VVM.
15. Verify that the MPC is fully seated in the VVM
16. Disconnect the MPC slings from the downloading device and lower them onto the MPC lid or remove them from the MPC.
17. Remove the temporary shielding and close the mating device drawer.

HOLTEC INTERNATIONAL COPYRIGHTED MATERIAL

Note:

The HI-TRAC pool lid may be reattached while positioned on the VVM or following HI-TRAC and mating device removal from the VVM.

18. Bolt the pool lid back onto the HI-TRAC.

ALARA Warning:

Personnel should remain clear (to the maximum extent practicable) of the HI-STORM annulus when HI-TRAC is removed to comply with ALARA requirements.

19. Remove the HI-TRAC transfer cask from on top of the VVM.

20. Open the mating device drawer and remove the MPC lift cleats and, if installed, the MPC slings.

21. Install hole plugs in the empty MPC bolt holes.

22. Close the mating device drawer and remove the mating device from on top of the VVM.

Warning:

Unless the lift is single failure proof (or equivalent safety factor) for the VVM lid, the lid shall be preferably kept less than 2 feet above the top surface of the VVM while over the MPC. This lift limit action is purely a defense-in-depth measure: the Closure Lid cannot fall and impact the MPC, as discussed in Supplement 1.I.

23. Install the VVM lid. See Figure 8.I.3 for lid rigging and Subsection 3.I.2 for the bounding lid weight.

24. Remove the VVM lid rigging equipment and re-install the outlet vent cover (if previously removed).

25. Install the HI-STORM temperature monitoring elements (if used).

26. Perform shielding effectiveness testing, as required.

8.I.2 ISFSI OPERATIONS

ISFSI operations for the HI-STORM 100U System are identical to the activities identified in Section 8.2. Additional operations related to the HI-STORM 100U System would include any periodic surveillance and maintenance activities required for the site specific cathodic protection system.

8.I.3 PROCEDURE FOR UNLOADING THE HI-STORM 100U SYSTEM IN THE SPENT FUEL POOL

8.I.3.1 Overview of HI-STORM 100U System Unloading Operations

The MPC is recovered from the HI-STORM 100U VVM at the ISFSI using the same methodologies as described in Subsection 8.I.1, except that the order is basically reversed. The VVM temperature monitoring elements (if used) and lid are removed. The mating device is

HOLTEC INTERNATIONAL COPYRIGHTED MATERIAL

installed and the mating device drawer is opened. The MPC lift cleats are attached to the MPC. The MPC slings are attached to the MPC lift cleats and positioned on the MPC lid. The mating device drawer is closed and the HI-TRAC is positioned on top of the mating device and VVM. The pool lid is unbolted from the HI-TRAC and the mating device drawer is opened. The MPC slings are brought through the HI-TRAC top lid and connected to the lift device. The MPC is raised into HI-TRAC and the mating device drawer is closed. The pool lid is bolted to the HI-TRAC. The HI-TRAC is removed from on top of the VVM and transported to the preparation area. The remainder of the unloading operation is carried out in accordance with the operations for the standard HI-STORM 100 System (See Subsection 8.3.3).

8.I.3.2 Preparing HI-STORM 100U System and HI-TRAC for Recovery from Storage

1. If necessary, perform a transport route walkdown to ensure that the cask transport conditions are met for transporting the loaded HI-TRAC transfer cask.
2. Perform a HI-TRAC receipt inspection and cleanliness inspection in accordance with a written inspection checklist. Transport the HI-TRAC to the ISFSI using the cask transporter or other suitable device.
3. Remove the VVM temperature monitoring equipment (if used).
4. Remove the outlet vent cover if necessary. Remove the VVM lid, preferably keeping its height above the top of the CEC Flange to under 2 feet. See Figure 8.I.3 for a rigging example and Subsection 3.I.2 for the bounding lid weight.
5. Install the mating device on the VVM.
6. Open the mating device drawer.
7. Remove the MPC lift cleat hole plugs and install the MPC lift cleats and MPC slings on the MPC lid. See Table 8.1.5 for torque requirements.
8. Close the mating device drawer.
9. If necessary, install the top lid on HI-TRAC. See Figure 8.1.9 for example rigging and Table 8.1.5 for torque requirements.
10. If previously drained, fill the neutron shield jacket with plant demineralized water or an approved antifreeze solution as necessary. Ensure that the fill and drain plugs are installed.
11. Align HI-TRAC over the mating device and VVM and mate the casks. See Figure 8.I.2.
12. Unbolt the pool lid from the HI-TRAC and lower into the mating device.
13. Open the mating device drawer.
14. At the user's discretion, install temporary shielding to cover the gap above and below the mating device drawer.

HOLTEC INTERNATIONAL COPYRIGHTED MATERIAL

15. Raise the MPC slings up through the HI-TRAC and attach them to the lifting device. See Figure 8.I.1.

ALARA Warning:

If temporary shielding is not used, personnel should remain clear of the immediate drawer area during MPC downloading.

Caution:

Limitations for the handling of the loaded MPC in HI-TRAC are evaluated and established on a canister basis to ensure that acceptable cladding temperatures are not exceeded. Refer to FSAR Chapter 4 for requirements on the use of the Supplemental Cooling System (SCS) to maintain fuel cladding temperatures below limits when MPCs with greater than threshold limits are transported in the HI-TRAC. Operation of the SCS normally continues until MPC cool-down and re-flooding operations have commenced. Staging and check-out of the SCS shall be completed prior to transferring the MPC to the HI-TRAC to minimize the time required to begin operations.

16. Raise the MPC into HI-TRAC.
17. Verify the MPC is in the full-up position.
18. Close the mating device drawer.
19. Bolt the pool lid to the HI-TRAC. See Table 8.1.5 for torque requirements.
20. Lower the MPC onto the pool lid.
21. Disconnect the slings from the lifting device and the MPC lift cleats.

Note:

Operation of the SCS will need to be postponed until the pool lid is in place on the HI-TRAC. Supplemental cooling shall begin, if required, by the provision in Chapter 4.

Warning:

At the start of SCS operations, the annulus fill water may flash to steam due to high MPC shell temperatures. Users may select the location and means of filling the annulus. Water addition should be performed in a slow and controlled manner until water steam generation has ceased.

22. If required, attach the SCS to the HI-TRAC annulus and begin circulating coolant. (See Figure 2.C.1). Continue operation of the SCS until MPC cool-down and re-flooding operations have commenced.
23. Remove HI-TRAC from the top of the VVM.
24. Transport the HI-TRAC to the designated preparation area using the cask transporter or other suitable device.
25. Install the VVM lid and outlet vent cover (if previously removed) to prevent entry of foreign objects into the VVM.

8.I.3.3 Preparation for Unloading

·HOLTEC INTERNATIONAL COPYRIGHTED MATERIAL

Perform the balance of the unloading operations in accordance with Subsection 8.3.3 beginning at Step 2.

8.I.3.4 MPC Unloading

For the HI-STORM 100U System, these activities are identical to those described in Subsection 8.3.4.

8.I.3.5 Post-Unloading Operations

For the HI-STORM 100U System, these activities are identical to those described in Subsection 8.3.5.

8.I.4 MPC TRANSFER TO A HI-STAR 100 OVERPACK FOR TRANSPORT OR STORAGE

For the HI-STORM 100U System, these activities are identical to those described in Section 8.4. MPC transfer to the HI-TRAC from the HI-STORM 100U VVM is addressed in Subsection 8.I.3 above as noted in Section 8.3.

8.I.5 MPC TRANSFER INTO THE HI-STORM 100U VVM DIRECTLY FROM TRANSPORT

For the HI-STORM 100U System, these activities are identical to those described in Section 8.5. MPC transfer to the HI-STORM 100U VVM from the HI-TRAC is addressed in Subsection 8.I.1 above as noted in Section 8.1.

HOLTEC INTERNATIONAL COPYRIGHTED MATERIAL

Table 8.I.1
HI-STORM 100U VVM INSPECTION CHECKLIST

Note:

This checklist provides the basis for establishing a site-specific inspection checklist for the HI-STORM 100U VVM. Specific findings shall be brought to the attention of the project management for assessment, evaluation and potential corrective action prior to use.

HI-STORM 100U VVM Lid:

1. The painted surfaces shall be inspected for corrosion and chipped, cracked or blistered paint.
2. All lid surfaces shall be relatively free of dents, scratches, gouges or other damage.
3. The lid shall be inspected for the presence or availability of studs, nuts, and hole plugs.
4. Lid lifting points shall be inspected for dirt, debris, and general condition.
5. Vent openings shall be free from obstructions.
6. Vent screens shall be available, intact, and free of holes and tears.
7. Temperature monitoring elements, if used, shall be inspected for availability, function, calibration and provisions for mounting to the VVM outlet air passage.

HI-STORM 100U VVM Main Body:

1. Cooling passages shall be free from obstructions.
2. The interior cavity shall be free of debris, litter, tools, and equipment.
3. Painted surfaces shall be inspected for corrosion, and chipped, cracked or blistered paint.

HOLTEC INTERNATIONAL COPYRIGHTED MATERIAL

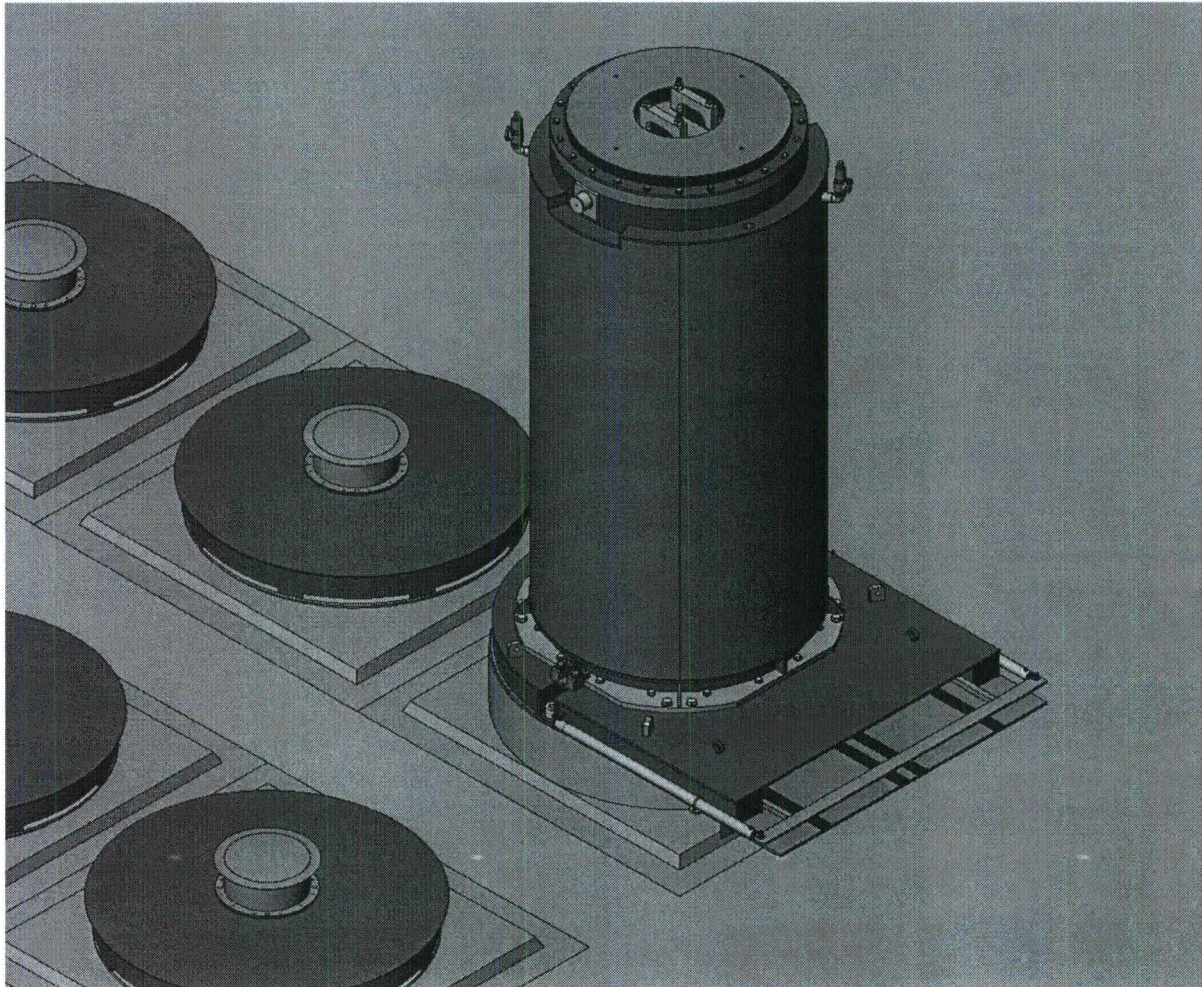


FIGURE 8.I.1: HI-TRAC ALIGNMENT AND PLACEMENT ON MATING DEVICE AND HI-STORM 100U* VVM

* The design features of the HI-STORM 100U System are the exclusive intellectual property of Holtec International under U.S. and international patents rights laws. Minor details of the HI-STORM 100U depicted here may vary slightly from the licensing drawings in Subsection 1.I.5.

HOLTEC INTERNATIONAL COPYRIGHTED MATERIAL

HI-STORM FSAR
REPORT HI-2002444

Rev. 9

HI-STORM 100 FSAR, NON-PROPRIETARY
REVISION 12
MARCH 12, 2014

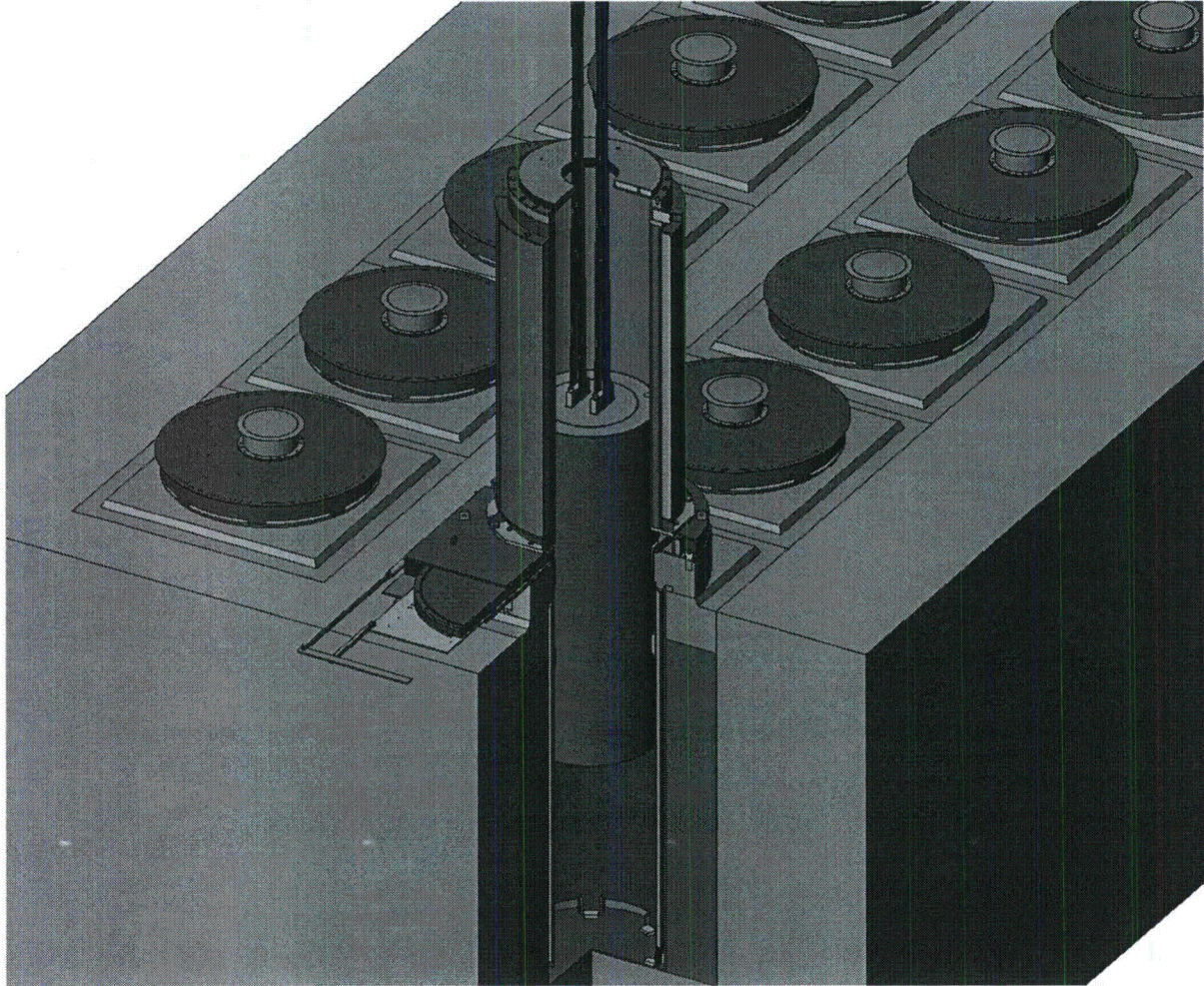


FIGURE 8.I.2: DOWNLOADING MPC INTO HI-STORM 100U* VVM

* The design features of the HI-STORM 100U System are the exclusive intellectual property of Holtec International under U.S. and international patents rights laws. Minor details of the HI-STORM 100U depicted here may vary slightly from the licensing drawings in Subsection 1.I.5.

HOLTEC INTERNATIONAL COPYRIGHTED MATERIAL

HI-STORM FSAR
REPORT HI-2002444

Rev. 9

HI-STORM 100 FSAR, NON-PROPRIETARY
REVISION 12
MARCH 12, 2014



FIGURE 8.I.3: EXAMPLE RIGGING CONFIGURATION FOR THE
HI-STORM 100U* VVM LID

* The design features of the HI-STORM 100U System are the exclusive intellectual property of Holtec International under U.S. and international patents rights laws. Minor details of the HI-STORM 100U depicted here may vary slightly from the licensing drawings in Subsection 1.I.5.

HOLTEC INTERNATIONAL COPYRIGHTED MATERIAL

HI-STORM FSAR
REPORT HI-2002444

Rev. 9

HI-STORM 100 FSAR, NON-PROPRIETARY
REVISION 12
MARCH 12, 2014

SUPPLEMENT 8.III

OPERATING PROCEDURES FOR THE MPC-68M

8.III.0 INTRODUCTION

This supplement provides clarifications and limitations to the procedures for loading, unloading, and recovery presented in Chapter 8 as applicable to the HI-STORM 100 System with an MPC-68M. The procedure steps outlined in Chapter 8 for loading, unloading, and recovery, remain applicable. Also see Subsection 1.III.2.2 of Supplement 1.III.

8.III.1 PROCEDURE FOR LOADING THE HI-STORM 100 SYSTEM IN THE SPENT FUEL POOL

A supplemental cooling system is not required when loading an MPC-68M. Thermal analysis results in Supplement 4.III show that for all short-term operations, excluding vacuum drying of high burnup fuel at high heat loads, the fuel cladding temperatures remain below the temperature limits in ISG-11, Rev 3 [2.0.8] for moderate and high burnup fuel.

Thermal analysis results in Supplement 4.III show that during vacuum drying and drying using the forced helium dehydrator (FHD) system the fuel cladding temperatures remain below the temperature limits in ISG-11, Rev 3 for moderate and high burnup fuel under the following conditions.

- When using a vacuum drying system (VDS) with an MPC-68M containing high burnup fuel, the MPC must be loaded uniformly with a maximum allowable decay heat per fuel storage location not to exceed 0.426 kW (total cask heat load \leq 29 kW).
- No limitations apply when using VDS with an MPC-68M containing all moderate burnup fuel up to design basis heat load.
- When using VDS to dry an MPC-68M with moderate or high burn up fuel at any heat load, the annulus space between the HI-TRAC and MPC must be filled with water. Flushing of the annulus space is not required.
- No limitations apply when using a forced helium dehydrator (FHD) system with MPC-68M containing moderate or high burnup fuel up to design basis heat load.

8.III.2 ISFSI OPERATIONS

Same as Section 8.2.

HOLTEC INTERNATIONAL COPYRIGHTED MATERIAL

8.III.3 PROCEDURE FOR UNLOADING THE HI-STORM 100 SYSTEM IN THE SPENT FUEL POOL

A supplemental cooling system is not required when unloading an MPC-68M. Thermal analysis results in Supplement 4.III show that for all short-term unloading operations the fuel cladding temperatures remain below the temperature limits in ISG-11, Rev 3 for moderate and high burnup fuel.

8.III.4 MPC TRANSPORT TO A HI-STAR 100 OVERPACK FOR TRANSPORT OR STORAGE

Same as Section 8.4.

8.III.5 MPC TRANSFER INTO THE HI-STORM 100 OVERPACK DIRECTLY FROM TRANSPORT

Same as Section 8.5.

CHAPTER 9[†]: ACCEPTANCE CRITERIA AND MAINTENANCE PROGRAM

9.0 INTRODUCTION

This chapter identifies the fabrication, inspection, test, and maintenance programs to be conducted on the HI-STORM 100 System, including the HI-TRAC transfer cask to verify that the structures, systems and components (SSCs) classified as important to safety have been fabricated, assembled, inspected, tested, accepted, and maintained in accordance with the requirements set forth in this FSAR, the applicable regulatory requirements, and the Certificate of Compliance (CoC). The acceptance criteria and maintenance program requirements specified in this chapter apply to each HI-STORM 100 System fabricated, assembled, inspected, tested, and accepted for use under the scope of the HI-STORM 100 System CoC, except as noted herein.

The controls, inspections, and tests set forth in this chapter, in conjunction with the design requirements described in previous chapters ensure that the HI-STORM 100 System will maintain confinement of radioactive material under normal, off-normal, and hypothetical accident conditions; will maintain subcriticality control; will properly transfer the decay heat of the stored radioactive materials; and that radiation doses will meet regulatory requirements.

Both pre-operational and operational tests and inspections are performed throughout HI-STORM 100 System operations to assure that the HI-STORM 100 System is functioning within its design parameters. These include receipt inspections, nondestructive weld examinations, pressure tests, radiation shielding tests, thermal performance tests, dryness tests, and others. Chapter 8 identifies the tests and inspections. "Pre-operation", as referred to in this section, defines that period of time from receipt inspection of a HI-STORM 100 System until the empty MPC is loaded into a HI-TRAC transfer cask for fuel assembly loading.

The HI-STORM 100 System is classified as important to safety. Therefore, the individual structures, systems, and components (SSCs) that make up the HI-STORM 100 System shall be designed, fabricated, assembled, inspected, tested, accepted, and maintained in accordance with a quality program commensurate with the particular SSC's graded quality category. Tables 2.2.6 and 8.1.6 provide the quality category for each major item or component of the HI-STORM 100 System and its ancillary equipment, respectively.

The acceptance criteria and maintenance program described in this chapter fully comply with the requirements of 10CFR72 [9.0.1] and NUREG-1536 [9.0.2], except as clarified in Table 1.0.3.

[†] This chapter has been prepared in the format and section organization set forth in Regulatory Guide 3.61. However, the material content of this chapter also fulfills the requirements of NUREG-1536. Pagination and numbering of sections, figures, and tables are consistent with the convention set down in Chapter 1, Section 1.0, herein. Finally, all terms-of-art used in this chapter are consistent with the terminology of the glossary (Table 1.0.1) and component nomenclature of the Bill-of-Materials (Section 1.5).

9.1 ACCEPTANCE CRITERIA

This section provides the workmanship inspections and acceptance tests to be performed on the HI-STORM 100 System prior to and during loading of the system. These inspections and tests provide assurance that the HI-STORM 100 System has been fabricated, assembled, inspected, tested, and accepted for use under the conditions specified in this FSAR and the Certificate of Compliance issued by the NRC in accordance with the requirements of 10CFR72 [9.0.1].

Identification and resolution of noncompliances shall be performed in accordance with the Holtec International Quality Assurance Program as described in Chapter 13 of this FSAR, or the licensee's NRC-approved Quality Assurance Program.

The testing and inspection acceptance criteria applicable to the MPCs, the HI-STORM 100 overpack, and the 100-ton HI-TRAC and 125-ton HI-TRAC transfer casks are listed in Tables 9.1.1, 9.1.2, and 9.1.3, respectively, and discussed in more detail in the sections that follow. Chapters 8 and 12 provide operating guidance and the bases for the Technical Specifications, respectively. These inspections and tests are intended to demonstrate that the HI-STORM 100 System has been fabricated, assembled, and examined in accordance with the design criteria contained in Chapter 2 of this FSAR.

This section summarizes the test program required for the HI-STORM 100 System.

9.1.1 Fabrication and Nondestructive Examination (NDE)

The design, fabrication, inspection, and testing of the HI-STORM 100 System is performed in accordance with the applicable codes and standards specified in Tables 2.2.6 and 2.2.7 and on the Design Drawings. Additional details on specific codes used are provided below.

The following fabrication controls and required inspections shall be performed on the HI-STORM 100 System, including the MPCs, overpacks, and HI-TRAC transfer casks, in order to assure compliance with this FSAR and the Certificate of Compliance.

1. Materials of construction specified for the HI-STORM 100 System are identified in the drawings in Chapter 1 and shall be procured with certification and supporting documentation as required by ASME Code [9.1.1] Section II (when applicable); the requirements of ASME Section III (when applicable); Holtec procurement specifications; and 10CFR72, Subpart G. Materials and components shall be receipt inspected for visual and dimensional acceptability, material conformance to specification requirements, and traceability markings, as applicable. Controls shall be in place to assure material traceability is maintained throughout fabrication. Materials for the confinement boundary (MPC baseplate, lid, closure ring, port cover plates and shell) shall also be inspected per the requirements of ASME Section III, Article NB-2500.

HOLTEC INTERNATIONAL COPYRIGHTED MATERIAL

2. The MPC confinement boundary shall be fabricated and inspected in accordance with ASME Code, Section III, Subsection NB, with alternatives as noted below. The MPC basket and basket supports shall be fabricated and inspected in accordance with ASME Code, Section III, Subsection NG, with alternatives as noted below. Metal components of the HI-TRAC transfer cask and the HI-STORM overpack, as applicable, shall be fabricated and inspected in accordance with ASME Code, Section III, Subsection NF, Class 3 or AWS D1.1, as shown on the design drawings, with alternatives as noted below.

NOTE: NRC-approved alternatives to these Code requirements are discussed in FSAR Section 2.2.4.

3. ASME Code welding shall be performed using welders and weld procedures that have been qualified in accordance with ASME Code Section IX and the applicable ASME Section III Subsections (e.g., NB, NG, or NF, as applicable to the SSC). AWS code welding may be performed using welders and weld procedures that have been qualified in accordance with applicable AWS requirements or in accordance with ASME Code Section IX
4. Welds shall be visually examined in accordance with ASME Code, Section V, Article 9 with acceptance criteria per ASME Code, Section III, Subsection NF, Article NF-5360, except the MPC fuel basket cell plate-to-cell plate welds and fuel basket support-to-canister welds which shall have acceptance criteria to ASME Code Section III, Subsection NG, Article NG-5360, (as modified by the design drawings). Table 9.1.4 identifies additional nondestructive examination (NDE) requirements to be performed on specific welds, and the applicable codes and acceptance criteria to be used in order to meet the inspection requirements of the applicable ASME Code, Section III. Acceptance criteria for NDE shall be in accordance with the applicable Code for which the item was fabricated. These additional NDE criteria are also specified on the design drawings for the specific welds. Weld inspections shall be detailed in a weld inspection plan which shall identify the weld and the examination requirements, the sequence of examination, and the acceptance criteria. The inspection plan shall be reviewed and approved by Holtec in accordance with its QA program. NDE inspections shall be performed in accordance with written and approved procedures by personnel qualified in accordance with SNT-TC-1A [9.1.2] or other site-specific, NRC-approved program for personnel qualification.

5. The MPC confinement boundary shall be examined and tested by a combination of methods (including helium leak test, pressure test, UT, MT and/or PT, as applicable) to verify that it is free of cracks, pinholes, uncontrolled voids or other defects that could significantly reduce its confinement effectiveness.
6. ASME Code welds requiring weld repair shall be repaired in accordance with the requirements of the ASME Code, Section III, Article NB-4450, NG-4450, or NF-4450, as applicable to the SSC, and examined after repair in the same manner as the original weld.
7. Base metal repairs shall be performed and examined in accordance with the applicable fabrication Code.
8. Grinding and machining operations on the MPC confinement boundary shall be controlled through written and approved procedures and quality assurance oversight to ensure grinding and machining operations do not reduce base metal wall thicknesses of the confinement boundary beyond that allowed per the design drawings. The thicknesses of base metals shall be ultrasonically tested, as necessary, in accordance with written and approved procedures to verify base metal thickness meets Design Drawing requirements. A nonconformance shall be written for areas found to be below allowable base metal thickness and shall be evaluated and repaired per the applicable ASME Code, Subsection NB requirements.
9. Dimensional inspections of the HI-STORM 100 System shall be performed in accordance with written and approved procedures in order to verify compliance to design drawings and fit-up of individual components. All dimensional inspections and functional fit-up tests shall be documented.
10. Required inspections shall be documented. The inspection documentation shall become part of the final quality documentation package.
11. The HI-STORM 100 System shall be inspected for cleanliness and proper packaging for shipping in accordance with written and approved procedures.
12. Each cask shall be durably marked with the appropriate model number, a unique identification number, and its empty weight per 10CFR72.236(k) at the completion of the acceptance test program.

13. A documentation package shall be prepared and maintained during fabrication of each HI-STORM 100 System to include detailed records and evidence that the required inspections and tests have been performed. The completed documentation package shall be reviewed to verify that the HI-STORM 100 System or component has been properly fabricated and inspected in accordance with the design and Code construction requirements. The documentation package shall include, but not be limited to:

- Completed Shop Weld Records
- Inspection Records
- Nonconformance Reports
- Material Test Reports
- NDE Reports
- Dimensional Inspection Report

9.1.1.1 MPC Lid-to-Shell Weld Volumetric Inspection

1. The MPC lid-to-shell (LTS) weld shall be volumetrically or multi-layer liquid penetrant (PT) examined following completion of welding. If volumetric examination is used, the ultrasonic testing (UT) method shall be employed. Ultrasonic techniques (including, as appropriate, Time-of-Flight Diffraction, Focussed Phased Array, and conventional pulse-echo) shall be supplemented, as necessary, to ensure substantially complete coverage of the examination volume.
2. If volumetric examination is used, then a PT examination of the root and final pass of the LTS weld shall also be performed and unacceptable indications shall be documented, repaired and re-examined.
3. If volumetric examination is not used, a multi-layer PT examination shall be employed. The multi-layer PT must, at a minimum, include the root and final weld layers and one intermediate PT after each approximately 3/8 inch weld depth has been completed. The 3/8 inch weld depth corresponds to the maximum allowable flaw size determined in Holtec Position Paper DS-213 [9.1.6].
4. The overall minimum thickness of the LTS weld has been increased by 0.125 inch over the size credited in the structural analyses, to provide additional structural capacity. A 0.625-inch J-groove weld was assumed in structural analyses in Chapter 3.
5. For either UT or PT, the maximum undetectable flaw size must be demonstrated to be less than the critical flaw size. The critical flaw size must be determined in accordance with ASME Section XI methods. The critical flaw size shall not cause the primary stress limits of NB-3000 to be exceeded. The inspection results,

HOLTEC INTERNATIONAL COPYRIGHTED MATERIAL

including relevant findings (indications) shall be made a permanent part of the cask user's records by video, photographic, or other means which provide an equivalent retrievable record of weld integrity. The video or photographic records should be taken during the final interpretation period described in ASME Section V, Article 6, T-676. The inspection of the weld shall be performed by qualified personnel and shall meet the acceptance requirements of ASME Section III, NB-5350 for PT and NB-5332 for UT.

6. Evaluation of any indications shall include consideration of any active flaw mechanisms. However, cyclic loading on the LTS weld is not significant, so fatigue is not a factor. The LTS weld is protected from the external environment by the closure ring and the root of the LTS weld is dry and inert (He atmosphere), so stress corrosion cracking is not a concern for the LTS weld.
7. The volumetric or multi-layer PT examination of the LTS weld, in conjunction with other examinations and tests performed on this weld (PT of root and final layer, and pressure test); the use of ASME Section III acceptance criteria, and the additional weld material added to account for potential defects in the root pass of the weld, in total, provide reasonable assurance that the LTS weld is sound and will perform its design function under all loading conditions. The volumetric (or multi-layer PT) examination and evaluation of indications provides reasonable assurance that leakage of the weld or structural failure under the design basis normal, off-normal, and accident loading conditions will not occur.

9.1.2 Structural and Pressure Tests

9.1.2.1 Lifting Trunnions

Two trunnions (located near the top of the HI-TRAC transfer cask) are provided for vertical lifting and handling. The trunnions are designed in accordance with ANSI N14.6 [9.1.3] using a high-strength and high-ductility material (see Chapter 1). The trunnions contain no welded components. The maximum design lifting load of 250,000 pounds for the HI-TRAC 125 and HI-TRAC 125D and 200,000 pounds for the HI-TRAC 100 and HI-TRAC 100D will occur during the removal of the HI-TRAC from the spent fuel pool after the MPC has been loaded, flooded with water, and the MPC lid is installed. The high-material ductility, absence of materials vulnerable to brittle fracture, large stress margins, and a carefully engineered design to eliminate local stress risers in the highly-stressed regions (during the lift operations) ensure that the lifting trunnions will work reliably. However, pursuant to the defense-in-depth approach of NUREG-0612 [9.1.4], the acceptance criteria for the lifting trunnions must be established in conjunction with other considerations applicable to heavy load handling.

Section 5 of NUREG-0612 calls for measures to "provide an adequate defense-in-depth for handling of heavy loads...". The NUREG-0612 guidelines cite four major causes of load handling accidents, of which rigging failure (including trunnion failure) is one:

- i. operator errors
- ii. rigging failure
- iii. lack of adequate inspection
- iv. inadequate procedures

The cask loading and handling operations program shall ensure maximum emphasis to mitigate the potential load drop accidents by implementing measures to eliminate shortcomings in all aspects of the operation including the four aforementioned areas.

In order to ensure that the lifting trunnions do not have any hidden material flaws, the trunnions shall be tested at 300% of the maximum design (service) lifting load. The load (750,000 lbs for the HI-TRAC 125 and HI-TRAC 125D and 600,000 lbs for the HI-TRAC 100 and 100D) shall be applied for a minimum of 10 minutes. The accessible parts of the trunnions (areas outside the HI-TRAC cask), and the adjacent HI-TRAC cask trunnion attachment area shall then be visually examined to verify no deformation, distortion, or cracking occurred. Any evidence of deformation, distortion or cracking of the trunnion or adjacent HI-TRAC cask trunnion attachment areas shall require replacement of the trunnion and/or repair of the HI-TRAC cask. Following any replacements and/or repair, the load testing shall be performed and the components re-examined in accordance with the original procedure and acceptance criteria. Testing shall be performed in accordance with written and approved procedures. Certified material test reports verifying trunnion material mechanical properties meet ASME Code Section II requirements will provide further verification of the trunnion load capabilities. Test results shall be documented. The documentation shall become part of the final quality documentation package.

The acceptance testing of the trunnions in the manner described above will provide adequate assurance against handling accidents.

9.1.2.2 Pressure Testing

9.1.2.2.1 HI-TRAC Transfer Cask Water Jacket

All 125-ton and 100-ton HI-TRAC transfer cask water jackets shall be hydrostatically tested to 75 psig +3, -0 psig, and 71 psig +3, -0 psig, respectively, in accordance with written and approved procedures. The water jacket fill port will be used for filling the cavity with water and the vent port for venting the cavity. The approved test procedure shall clearly define the test equipment arrangement.

The hydrostatic test shall be performed after the water jacket has been welded together. The test pressure gage installed on the water jacket shall be graduated over a range not less than 1.5 times nor

more than 4 times the test pressure. Digital type pressure gages may be used without range restriction provided the combined error due to calibration and readability does not exceed 1% of the test pressure. The hydrostatic test pressure shall be maintained for ten minutes. During this time period, the pressure gage shall not fall below the applicable minimum test pressure. At the end of ten minutes, and while the pressure is being maintained at the minimum pressure, weld joints shall be visually examined for leakage. If a leak is discovered, the cavity shall be emptied and an examination to determine the cause of the leakage shall be made. Repairs and retest shall be performed until the hydrostatic test criteria are met.

After completion of the hydrostatic testing, the water jacket exterior surfaces shall be visually examined for cracking or deformation. Evidence of cracking or deformation shall be cause for rejection, or repair and retest, as applicable. Liquid penetrant (PT) or magnetic particle (MT) examination of accessible welds shall be performed in accordance with ASME Code, Section V, Articles 6 and 7, respectively, with acceptance criteria per ASME Code, Section III, Subsection NF, Articles NF-5350 and NF-5340, respectively. Unacceptable areas shall require repair and re-examination per the applicable ASME Code. The HI-TRAC water jacket hydrostatic test shall be repeated until all examinations are found to be acceptable.

If a hydrostatic retest is required and fails, a nonconformance report shall be issued and a root cause evaluation and appropriate corrective actions taken before further repairs and retests are performed.

Test results shall be documented. The documentation shall become part of the final quality documentation package.

9.1.2.2.2 MPC Confinement Boundary

Pressure testing (hydrostatic or pneumatic) of the MPC confinement boundary shall be performed in accordance with the requirements of the ASME Code Section III, Subsection NB, Article NB-6000 and applicable sub-articles, when field welding of the MPC lid-to-shell weld is completed. If hydrostatic testing is used, the MPC shall be pressure tested to 125% of design pressure. If pneumatic testing is used, the MPC shall be pressure tested to 120% of design pressure. The MPC vent and drain ports will be used for pressurizing the MPC cavity. The loading procedures in FSAR Chapter 8 define the test equipment arrangement. The calibrated test pressure gage installed on the MPC confinement boundary shall have an upper limit of approximately twice that of the test pressure. Following completion of the required hold period at the test pressure, the surface of the MPC lid-to-shell weld shall be re-examined by liquid penetrant examination in accordance with ASME Code, Section III, Subsection NB, Article NB-5350 acceptance criteria. Any evidence of cracking or deformation shall be cause for rejection, or repair and retest, as applicable. The performance and sequence of the test is described in FSAR Section 8.1 (loading procedures).

If a leak is discovered, the test pressure shall be reduced, the MPC cavity water level lowered, if applicable, the MPC cavity vented, and the weld shall be examined to determine the cause of the leakage and/or cracking. Repairs to the weld shall be performed in accordance with written and

approved procedures prepared in accordance with the ASME Code, Section III, Article NB-4450.

The MPC confinement boundary pressure test shall be repeated until all required examinations are found to be acceptable. Test results shall be documented and maintained as part of the loaded MPC quality documentation package.

9.1.2.3 Materials Testing

The majority of materials used in the HI-TRAC transfer cask and a portion of the material in the HI-STORM overpack are ferritic steels. ASME Code, Section II and Section III require that certain materials be tested in order to assure that these materials are not subject to brittle fracture failures.

Materials of the HI-TRAC transfer cask and HI-STORM overpack, as required, shall be Charpy V-notch tested in accordance with ASME Section IIA and/or ASME Section III, Subsection NF, Articles NF-2300, and NF-2430. The materials to be tested include the components identified in Table 3.1.18 and applicable weld materials. Table 3.1.18 provides the test temperatures and test acceptance criteria to be used when performing the material testing specified above.

The concrete utilized in the construction of the HI-STORM overpack shall be mixed, poured, and tested as described in FSAR Appendix 1.D in accordance with written and approved procedures. Testing shall verify the composition, compressive strength, and density meet design requirements.

Concrete testing shall be performed for each lot of concrete. Concrete testing shall comply with Appendix 1.D.

Test results shall be documented and become part of the final quality documentation package.

9.1.3 Leakage Testing

Leakage testing shall be performed in accordance with the requirements of ANSI N14.5 [9.1.5]. Testing shall be performed in accordance with written and approved procedures.

Helium leakage testing of the MPC base metals (shell, baseplate, and MPC lid) and MPC shell to baseplate and shell to shell welds is performed on the unloaded MPC. The acceptance criterion is "leaktight" as defined in ANSI N14.5.

The helium leakage test of the vent and drain port cover plate welds shall be performed using a helium mass spectrometer leak detector (MSLD). If a leakage rate exceeding the acceptance criterion is detected, then the area of leakage shall be determined and the area repaired per ASME Code Section III, Subsection NB, Article NB-4450 requirements. Re-testing shall be performed until the leakage rate acceptance criteria is met.

Leakage testing of the field welded MPC lid-to-shell weld and closure ring welds are not required.

HOLTEC INTERNATIONAL COPYRIGHTED MATERIAL

Leak testing results for the MPC shall be documented and shall become part of the quality record documentation package.

Leakage testing of the vent and drain port cover plates shall be performed after welding of the cover plates and subsequent NDE. The description and procedures for these field leakage tests are provided in FSAR Section 8.1 and the acceptance criteria are defined in the Technical Specifications in Appendix A to CoC 72-1014

9.1.4 Component Tests

9.1.4.1 Valves, Rupture Discs, and Fluid Transport Devices

There are no fluid transport devices or rupture discs associated with the HI-STORM 100 System. The only valve-like components in the HI-STORM 100 System are the specially designed caps installed in the MPC lid for the drain and vent ports. These caps are recessed inside the MPC lid and covered by the fully-welded vent and drain port cover plates. No credit is taken for the caps' ability to confine helium or radioactivity. After completion of drying and backfill operations, the drain and vent port cover plates are welded in place on the MPC lid and are liquid penetrant examined and leakage tested to verify the MPC confinement boundary.

There are two pressure relief valves installed in the upper ledge surface of the HI-TRAC transfer cask water jacket. These pressure relief valves are provided for venting of the neutron shield jacket fluid under hypothetical fire accident conditions in which the design pressure of the water jacket may be exceeded. The pressure relief valves shall relieve at 60 psig and 65 psig.

9.1.4.2 Seals and Gaskets

There are no confinement seals or gaskets included in the HI-STORM 100 System.

9.1.5 Shielding Integrity

The HI-STORM overpack and MPC have two designed shields for neutron and gamma ray attenuation. The HI-STORM overpack concrete provides both neutron and gamma shielding. Additional neutron shielding is provided by the encased neutron absorber attached to the fuel basket cell surfaces inside the MPCs. The overpack's inner and outer steel shells, and the steel shield shell[†] provide radial gamma shielding. Concrete and steel plates provide axial neutron and gamma shielding. A concrete ring attached to the top of the overpack lid provides additional gamma and

[†] The shield shell design feature was deleted in June, 2001 after overpack serial number 7 was fabricated. Those overpacks without the shield shell are required to have a higher concrete density in the overpack body to provide compensatory shielding. See Table 1.D.1.

neutron shielding in the axial direction. Steel gamma shield cross plates, installed in the overpack air inlet and outlet vents, provide additional shielding for radiation through the vent openings.

The HI-TRAC transfer cask uses three different materials for primary shielding. All HI-TRAC transfer cask designs include a radial steel-lead-steel shield and a steel-lead-steel pool lid design. The top lid in the HI-TRAC 125 and HI-TRAC 125D designs includes Holtite neutron shielding inside a steel enclosure. The HI-TRAC 100 and 100D top lids include only steel shielding. The HI-TRAC 125 transfer lid includes steel, lead, and Holtite, while the HI-TRAC 100 includes only steel and lead. The HI-TRAC 100D and 125D designs do not include a transfer lid. The water jacket, included in all transfer cask designs, provides radial neutron shielding. Testing requirements for the shielding items are described below.

9.1.5.1 Fabrication Testing and Control

Holtite-A:

Neutron shield properties of Holtite-A are provided in Chapter 1, Section 1.2.1.3.2. Each manufactured lot of neutron shield material shall be tested to verify the material composition (aluminum and hydrogen), boron concentration and neutron shield density (or specific gravity) meet the requirements specified in Chapter 1 and the Bill-of-Material. A manufactured lot is defined as the total amount of material used to make any number of mixed batches comprised of constituent ingredients from the same lot/batch identification numbers supplied by the constituent manufacturer. Testing shall be performed in accordance with written and approved procedures and/or standards. Material composition, boron concentration and density (or specific gravity) data for each manufactured lot of neutron shield material shall become part of the quality documentation package.

The installation of the neutron shielding material shall be performed in accordance with written and qualified procedures. The procedures shall ensure that mix ratios and mixing methods are controlled in order to achieve proper material composition, boron concentration and distribution, and that pours are controlled in order to prevent gaps from occurring in the material. Samples of each manufactured lot of neutron shield material shall be maintained by Holtec International as part of the quality record documentation package.

Concrete:

The dimensions of the HI-STORM overpack steel shells and the density of the concrete shall be verified to be in accordance with FSAR Appendix 1.D and the design drawings prior to concrete installation. The dimensional inspection and density measurements shall be documented. Also, see Subsection 9.1.2.3 for concrete material testing requirements.

Lead:

The installation of the lead in the HI-TRAC transfer cask shall be performed using written and

qualified procedures in order to ensure voids are minimized. The lead shall be tested for chemical composition.

As an alternative to pouring molten lead, the HI-TRAC lead shielding may be installed as pre-cast sections, or lead sheets. If pre-cast sections or sheets are used, the design of the sections and the installations instructions shall minimize the gaps between adjacent lead sections and between the lead and the transfer cask walls to the extent practicable.

Steel:

Steel plates utilized in the construction of the HI-STORM 100 System shall be dimensionally inspected to assure compliance with the requirements specified on the Design Drawings.

General Requirements for Shield Materials:

1. Test results shall be documented and become part of the quality documentation package.
2. Dimensional inspections of the cavities containing the shielding materials shall assure that the design required amount of shielding material is being incorporated into the fabricated item.

Shielding effectiveness tests shall be performed during fabrication and again after initial loading operations in accordance with Section 9.1.5.2 below and the operating procedures in Chapter 8.

9.1.5.2 Shielding Effectiveness Tests

The effectiveness of the lead pours in the HI-TRAC transfer cask body shall be verified during fabrication by performing gamma scanning on all accessible surfaces of the cask in the lead pour region. The gamma scanning may be performed prior to, or after installation of the water jacket. The purpose of the gamma scanning test is to demonstrate that the gamma shielding of the transfer cask body is at least as effective as that of a lead and steel test block. For the test block, the steel thickness shall be equivalent to the minimum design thickness of steel in the transfer cask component and the lead thickness shall be 5 percent lower than the minimum design thickness of lead in the transfer cask component (see the Design Drawings for the design values). Data shall be recorded on a 6-inch by 6-inch (nominal) grid pattern over the surfaces to be scanned. Should the measured gamma dose rates exceed those established with the test block, the shielding of that transfer cask component shall be deemed unacceptable. Corrective actions should be taken, if practicable, and the testing re-performed until successful results are achieved. If physical corrective actions are not practicable, the degraded condition may be dispositioned with a written evaluation in accordance with applicable procedures to determine the acceptability of the transfer cask for service. Gamma scanning shall be performed in accordance with written and approved procedures. Dose rate measurements shall be documented and shall become part of the quality documentation package.

HOLTEC INTERNATIONAL COPYRIGHTED MATERIAL

HI-STORM FSAR
REPORT HI-2002444

9.1-11

Rev. 11

As an alternative to poured lead, the lead shielding inside the HI-TRAC transfer cask body may be made of individual lead sheets layered together. The minimum total thickness of lead sheets installed in the cask body shall be verified to meet the licensing drawing including tolerance. The effectiveness of each lead sheet shall be verified by visual examination. The visual examination includes absence of cracks, pores, inclusions, scratches, grooves, or other types of defects that could impair the gamma shielding function of the lead. Defects which exceed a depth of 10% of the plate thickness and an area greater than one square inch shall be rejected. Lead sheets thicker than 3/16" (nominal) shall be subject to UT testing. The UT testing will take place before the installation of the plates. The UT testing ensures that the plates are uniform internally. This is an accepted industry procedure for locating voids within the lead sheets in order to verify the shielding effectiveness of the sheets.

The effectiveness of the lead plates in the HI-TRAC pool lid (all transfer cask designs) and transfer lid (HI-TRAC 125 and 100 only) shall be verified during fabrication by performing a UT test of the lead plates. The UT testing will take place before the installation of the plates. The UT testing ensures that the plates are uniform internally. This is an accepted industry procedure for locating voids within the lead plate in order to verify the shielding effectiveness of the plate.

Following the first fuel loading of each HI-STORM 100 System (HI-TRAC transfer cask and HI-STORM storage overpack), a shielding effectiveness test shall be performed at the loading facility site to verify the effectiveness of the radiation shield. This test shall be performed after the HI-STORM overpack and HI-TRAC transfer cask have been loaded with an MPC containing spent fuel assemblies and the MPC has been drained, moisture removed, and backfilled with helium.

Operational neutron and gamma shielding effectiveness tests shall be performed after fuel loading using written and approved procedures. Calibrated neutron and gamma dose rate meters shall be used to measure the actual neutron and gamma dose rates at the surface of the HI-STORM overpack and HI-TRAC. Measurements shall be taken at the locations specified in the Radiation Protection Program for comparison against the prescribed limits. The test is considered acceptable if the dose rate readings are less than or equal to the calculated limits. If dose rates are higher than the limits, the required actions provided in the Radiation Protection Program shall be completed. Dose rate measurements shall be documented and shall become part of the quality documentation package.

NOTE

Section 9.1.5.3 below (including Subsections 9.1.5.3.1 through 9.1.5.3.3) is incorporated into the HI-STORM 100 CoC by reference (CoC Appendix B, Section 3.2.8) and may not be deleted or altered in any way without prior NRC approval via CoC amendment. The text of this section is, therefore, shown in bold type to distinguish it from other text.

9.1.5.3 Neutron Absorber Tests

HOLTEC INTERNATIONAL COPYRIGHTED MATERIAL

HI-STORM FSAR
REPORT HI-2002444

9.1-12

Rev. 11

Each plate of neutron absorber shall be visually inspected for damage such as scratches, cracks, burrs, peeled cladding, foreign material embedded in the surfaces, voids, delamination, and surface finish, as applicable.

9.1.5.3.1 Boral (75% Credit)

After manufacturing, a statistical sample of each lot of neutron absorber shall be tested using wet chemistry and/or neutron attenuation testing to verify a minimum ^{10}B content (areal density) in samples taken from the ends of the panel. The minimum ^{10}B loading of the neutron absorber panels for each MPC model is provided in Table 2.1.15. Any panel in which ^{10}B loading is less than the minimum allowed shall be rejected. Testing shall be performed using written and approved procedures. Results shall be documented and become part of the cask quality records documentation package.

9.1.5.3.2 METAMIC[®] (90% Credit)

NUREG/CR-5661 identifies the main reason for a penalty in the neutron absorber B-10 density as the potential of neutron streaming due to non-uniformities in the neutron absorber, and recommends comprehensive acceptance tests to verify the presence and uniformity of the neutron absorber for credits more than 75%. Since a 90% credit is taken for METAMIC[®], the following criteria must be satisfied:

- The boron carbide powder used in the manufacturing of METAMIC[®] must have small particle sizes to preclude neutron streaming
- The ^{10}B areal density must comply with the limits of Table 2.1.15.
- The B_4C powder must be uniformly dispersed locally, i.e. must not show any particle agglomeration. This precludes neutron streaming.
- The B_4C powder must be uniformly dispersed macroscopically, i.e. must have a consistent concentration throughout the entire neutron absorber panel.
- The maximum B_4C content in METAMIC[®] shall be less than or equal to 33.0 weight percent.

To ensure that the above requirements are met the following tests shall be performed:

- All lots of boron carbide powder are analyzed to meet particle size distribution requirements.
- The following qualification testing shall be performed on the first production run of METAMIC[®] panels for the MPCs in order to validate the acceptability and consistency of

the manufacturing process and verify the acceptability of the METAMIC® panels for neutron absorbing capabilities:

- 1) The boron carbide powder weight percent shall be verified by testing a sample from forty different mixed batches. (A mixed batch is defined as a single mixture of aluminum powder and boron carbide powder used to make one or more billets. Each billet will produce several panels.) The samples shall be drawn from the mixing containers after mixing operations have been completed. Testing shall be performed using the wet chemistry method.
 - 2) The ^{10}B areal density shall be verified by testing a sample from one panel from each of forty different mixed batches. The samples shall be drawn from areas contiguous to the manufactured panels of METAMIC® and shall be tested using the wet chemistry method. Alternatively, or in addition to the wet chemistry tests, neutron attenuation tests on the samples may be performed to quantify the actual ^{10}B areal density.
 - 3) To verify the local uniformity of the boron particle dispersal, neutron attenuation measurements of random test coupons shall be performed. These test coupons may come from the production run or from pre-production trial runs.
 - 4) To verify the macroscopic uniformity of the boron particle distribution, test samples shall be taken from the sides of one panel from five different mixed batches before the panels are cut to their final sizes. The sample locations shall be chosen to be representative of the final product. Wet chemistry or neutron attenuation shall be performed on each of the samples.
- During production runs, testing of mixed batches shall be performed on a statistical basis to verify the correct boron carbide weight percent is being mixed.
 - During production runs, samples from random METAMIC® panels taken from areas contiguous to the manufactured panels shall be tested via wet chemistry and/or neutron attenuation testing to verify the ^{10}B areal density. This test shall be performed to verify the continued acceptability of the manufacturing process.

The measurements of B_4C particle size, ^{10}B isotopic assay, uniformity of B_4C distribution and ^{10}B areal density shall be made using written and approved procedures. Results shall be documented.

9.1.5.3.3 Installation of the Neutron Absorber Panels

Installation of neutron absorber panels into the fuel basket shall be performed in accordance with written and approved instructions. Travelers and quality control procedures shall be in place to assure each required cell wall of the MPC basket contains a neutron absorber panel in

HOLTEC INTERNATIONAL COPYRIGHTED MATERIAL

accordance with drawings in Chapter 1. These quality control processes, in conjunction with in-process manufacturing testing, provide the necessary assurances that the neutron absorber will perform its intended function. No additional testing or in-service monitoring of the neutron absorber material will be required.

9.1.6 Thermal Acceptance Tests

The thermal performance of the HI-STORM 100 System, including the MPCs and HI-TRAC transfer casks, is demonstrated through analysis in Chapter 4 of the FSAR. Dimensional inspections to verify the item has been fabricated to the dimensions provided in the drawings shall be performed prior to system loading. Following the loading and placement on the storage pad of the first HI-STORM System placed in service, the operability of the natural convective cooling of the HI-STORM 100 System shall be verified by the performance of an air temperature rise test. A description of the test is described in FSAR Chapter 8.

In addition, the technical specifications require periodic surveillance of the overpack air inlet and outlet vents or, optionally, implementation of an overpack air temperature monitoring program to provide continued assurance of the operability of the HI-STORM 100 heat removal system.

9.1.7 Cask Identification

Each MPC, HI-STORM overpack, and HI-TRAC transfer cask shall be marked with a model number, identification number (to provide traceability back to documentation), and the empty weight of the item in accordance with the marking requirements specified in 10 CFR 72.236(k).

Table 9.1.1
MPC INSPECTION AND TEST ACCEPTANCE CRITERIA

Function	Fabrication	Pre-operation	Maintenance and Operations
Visual Inspection and Nondestructive Examination (NDE)	<ul style="list-style-type: none"> a) Examination of MPC components per ASME Code Section III, Subsections NB and NG, as defined on design drawings, per NB-5300 and NG-5300, as applicable. b) A dimensional inspection of the internal basket assembly and canister shall be performed to verify compliance with design requirements. c) A dimensional inspection of the MPC lid and MPC closure ring shall be performed prior to inserting into the canister shell to verify compliance with design requirements. d) NDE of weldments are defined on the design drawings using standard American Welding Society NDE symbols and/or notations. e) Cleanliness of the MPC shall be verified upon completion of fabrication. f) The packaging of the MPC at the completion of fabrication shall be verified prior to shipment. 	<ul style="list-style-type: none"> a) The MPC shall be visually inspected prior to placement in service at the licensee's facility. b) MPC protection at the licensee's facility shall be verified. c) MPC cleanliness and exclusion of foreign material shall be verified prior to placing in the spent fuel pool. 	<ul style="list-style-type: none"> a) None.

Table 9.1.1 (continued)
MPC INSPECTION AND TEST ACCEPTANCE CRITERIA

Function	Fabrication	Pre-operation	Maintenance and Operations
Structural	<p>a) Assembly and welding of MPC components shall be performed per ASME Code Section IX and III, Subsections NB and NG, as applicable.</p> <p>b) Materials analysis (steel, neutron absorber, etc.), shall be performed and records shall be kept in a manner commensurate with "important to safety" classifications.</p>	<p>a) None.</p>	<p>a) An ultrasonic (UT) examination or multi-layer liquid penetrant (PT) examination of the MPC lid-to-shell weld shall be performed per ASME Section V, Article 5 (or ASME Section V, Article 2). Acceptance criteria for the examination are defined in Subsection 9.1.1.1 and in the Design Drawings.</p> <p>b) ASME Code NB-6000 pressure test shall be performed after MPC closure welding. Acceptance criteria are defined in the Code.</p>
Leak Tests	<p>a) Helium leakage testing of the MPC shell and MPC shell to baseplate welds is performed on the unloaded MPC.</p> <p>b) Helium leakage testing of the MPC base metals (shell, baseplate, lid) is performed.</p>	<p>a) None.</p>	<p>a) Helium leak rate testing shall be performed on the vent and drain port cover plate to MPC lid field welds and the cover plate base metals. See Technical Specification Bases in Chapter 12 for guidance on acceptance criteria.</p>

Table 9.1.1 (continued)			
MPC INSPECTION AND TEST ACCEPTANCE CRITERIA			
Function	Fabrication	Pre-operation	Maintenance and Operations
Criticality Safety	a) The boron content shall be verified at the time of neutron absorber material manufacture. b) The installation of neutron absorber panels into MPC basket plates shall be verified by inspection.	a) None.	a) None.
Shielding Integrity	a) Material compliance shall be verified through CMTRs. b) Dimensional verification of MPC lid thickness shall be performed.	a) None.	a) None.
Thermal Acceptance	a) None.	a) None.	a) None.
Fit-Up Tests	a) Fit-up of the following components is to be tested during fabrication. - MPC lid - vent/drain port cover plates - MPC closure ring b) A gauge test of all basket fuel compartments.	a) Fit-up of the following components shall be verified during pre-operation. - MPC lid - MPC closure ring - vent/drain cover plates	a) None.
Canister Identification Inspections	a) Verification of identification marking applied at completion of fabrication.	a) Identification marking shall be checked for legibility during pre-operation.	a) None.

**Table 9.1.2
HI-STORM STORAGE OVERPACK INSPECTION AND TEST ACCEPTANCE CRITERIA**

Function	Fabrication	Pre-operation	Maintenance and Operations
<p>Visual Inspection and Nondestructive Examination (NDE)</p>	<p>Structural Steel Components:</p> <p>a) All ASME and AWS welds shall be visually examined per ASME Section V, Article 9 with acceptance criteria per ASME Section III, Subsection NF, NF-5360.</p> <p>b) All welds requiring PT examination as shown on the Design Drawings shall be PT examined per ASME Section V, Article 6 with acceptance criteria per ASME Section III, Subsection NF, NF-5350.</p> <p>c) All welds requiring MT examination as shown on the drawings shall be MT examined per ASME Section V, Article 7 with acceptance criteria per ASME Section III, Subsection NF, NF-5340.</p> <p>d) NDE of weldments shall be defined on design drawings using standard AWS NDE symbols and/or notations.</p> <p>Concrete Components: The following processes related to concrete components shall be implemented per ACI 349 as clarified in FSAR Appendix 1.D. Concrete testing shall be in accordance with Table 1.D.2. Activities shall be conducted in accordance with written and approved procedures.</p> <p>a) Assembly and examination. b) Materials verification. c) Mixing, pouring, and testing.</p>	<p>a) The overpack shall be visually inspected prior to placement in service.</p> <p>b) Fit-up with mating components (e.g., lid) shall be performed directly whenever practical or using templates or other means.</p> <p>c) Overpack protection at the licensee's facility shall be verified.</p> <p>d) Exclusion of foreign material shall be verified prior to placing the overpack in service at the licensee's facility.</p>	<p>a) Indications identified during visual inspection shall be corrected, reconciled, or otherwise dispositioned .</p> <p>b) Exposed surfaces shall be monitored for coating deterioration and repair/recoat as necessary.</p>

Table 9.1.2 (continued)
HI-STORM STORAGE OVERPACK INSPECTION AND TEST ACCEPTANCE CRITERIA

Function	Fabrication	Pre-operation	Maintenance and Operations
Visual Inspection and Nondestructive Examination (NDE) (continued)	General: a) Cleanliness of the overpack shall be verified upon completion of fabrication. b) Packaging of the overpack at the completion of shop fabrication shall be verified prior to shipment.		
Structural	a) No structural or pressure tests are required for the overpack during fabrication. b) Concrete compressive strength tests shall be performed per Appendix 1.D.	a) No structural or pressure tests are required for the overpack during pre-operation.	a) No structural or pressure tests are required for the overpack during operation.
Leak Tests	a) None.	a) None.	a) None.
Criticality Safety	a) No neutron absorber tests of the overpack are required for criticality safety during fabrication.	a) None.	a) None.
Shielding Integrity	a) Concrete density shall be verified per ACI-349 as clarified by FSAR Appendix 1.D, at time of placement. b) Shell thicknesses and dimensions between inner and outer shells shall be verified as conforming to design drawings prior to concrete placement. c) Verification of material composition shall be performed.	a) None	a) A shielding effectiveness test shall be performed after the initial fuel loading.

Table 9.1.2 (continued)
HI-STORM STORAGE OVERPACK INSPECTION AND TEST ACCEPTANCE CRITERIA

Function	Fabrication	Pre-operation	Maintenance and Operations
Thermal Acceptance	a) Inner shell I.D. and vent size, configuration and placement shall be verified.	a) No pre-operational testing related to the thermal characteristics of the overpack is required.	a) Air temperature rise test(s) shall be performed after initial loading of the first HI-STORM 100 System in accordance with the operating procedures in Chapter 8. b) Periodic surveillance shall be performed by either (1) or (2) below, at the licensee's discretion. (1) Inspection of overpack inlet and outlet air vent openings for debris and other obstructions. (2) Temperature monitoring.
Cask Identification	a) Verification that the overpack identification is present in accordance with the drawings shall be performed upon completion of assembly.	a) The overpack identification shall be checked prior to loading.	a) The overpack identification shall be periodically inspected per licensee procedures and repaired or replaced if damaged.
Fit-up Tests	a) Lid fit-up with the overpack shall be verified following fabrication.	a) None.	a) None.

Table 9.1.3
HI-TRAC TRANSFER CASK INSPECTION AND TEST ACCEPTANCE CRITERIA

Function	Fabrication	Pre-operation	Maintenance and Operations
Visual Inspection and Nondestructive Examination (NDE)	a) All ASME and AWS welds shall be visually examined per ASME Section V, Article 9 with acceptance criteria per ASME Section III, Subsection NF, NF-5360. b) All welds requiring PT examination as shown on the Design Drawings shall be PT examined per ASME Section V, Article 6 with acceptance criteria per ASME Section III, Subsection NF, NF-5350. c) All welds requiring MT examination as shown on the Design Drawings shall be MT examined per ASME Section V, Article 7 with acceptance criteria per ASME Section III, Subsection NF, NF-5340. d) NDE of weldments shall be defined on design drawings using standard AWS NDE symbols and/or notations e) Cleanliness of the transfer cask shall be verified upon completion of fabrication. f) Packaging of the transfer cask at the completion of fabrication shall be verified prior to shipment.	a) The transfer cask shall be visually inspected prior to placement in service. b) Transfer cask protection at the licensee's facility shall be verified. c) Transfer cask cleanliness and exclusion of foreign material shall be verified prior to use.	a) Annual visual inspections of the transfer cask shall be performed to assure continued compliance with drawing requirements. (See footnote for Table 9.2.1).

Table 9.1.3 (continued)			
HI-TRAC TRANSFER CASK INSPECTION AND TEST ACCEPTANCE CRITERIA			
Function	Fabrication	Pre-operation	Maintenance and Operations
Structural	a) Verification of structural materials shall be performed through receipt inspection and review of certified material test reports (CMTRs) obtained in accordance with the item's quality category.	a) None.	a) Testing to verify continuing compliance of the lifting trunnions shall be performed per ANSI N14.6. (See footnote to Table 9.2.1).
	a) A load test of the lifting trunnions shall be performed during fabrication per ANSI N14.6. b) A pressure test of the neutron shield water jacket shall be performed during fabrication.		b) The set pressure of the relief valve on the neutron shield water jacket shall be verified by calibration annually. (See footnote to Table 9.2.1)
Leak Tests	a) None.	a) None.	a) None.
Criticality Safety	a) None.	a) None.	a) None.

Table 9.1.3 (continued)
TRANSFER CASK INSPECTION AND TEST ACCEPTANCE CRITERIA

Function	Fabrication	Pre-operation	Maintenance and Operations
Thermal Acceptance	a) The thermal properties of the transfer cask are established by calculation and inspection, and are not tested during fabrication.	a) None.	a) None
Cask Identification	a) Verification that the transfer cask identification is present in accordance with the drawings shall be performed upon completion of assembly.	a) The transfer cask identification shall be checked prior to loading..	a) The transfer cask identification shall be periodically inspected per licensee procedures and repaired or replaced if damaged.
Fit-up Tests	a) Fit-up tests of the transfer cask components (top, in-pool, and transfer lids) shall be performed during fabrication.	a) Fit-up test of the transfer cask lifting trunnions with the transfer cask lifting yoke shall be performed. b) Fit-up test of the transfer cask pocket trunnions with the horizontal transfer skid shall be performed.	a) Fit-up of the top, in-pool, and transfer lids shall be verified prior to use.

Table 9.1.4
 HI-STORM 100 NDE REQUIREMENTS

MPC			
Weld Location	NDE Requirement	Applicable Code	Acceptance Criteria (Applicable Code)
Shell longitudinal seam	RT	ASME Section V, Article 2 (RT)	RT: ASME Section III, Subsection NB, Article NB-5320
	PT (surface)	ASME Section V, Article 6 (PT)	PT: ASME Section III, Subsection NB, Article NB-5350
Shell circumferential seam	RT	ASME Section V, Article 2 (RT)	RT: ASME Section III, Subsection NB, Article NB-5320
	PT (surface)	ASME Section V, Article 6 (PT)	PT: ASME Section III, Subsection NB, Article NB-5350
Baseplate-to-shell	RT or UT	ASME Section V, Article 2 (RT) ASME Section V, Article 5 (UT)	RT: ASME Section III, Subsection NB, Article NB-5320 UT: ASME Section III, Subsection NB, Article NB-5330
	PT (surface)	ASME Section V, Article 6 (PT)	PT: ASME Section III, Subsection NB, Article NB-5350

Table 9.1.4 (continued)
HI-STORM 100 NDE REQUIREMENTS

MPC			
Weld Location	NDE Requirement	Applicable Code	Acceptance Criteria (Applicable Code)
Lid-to-shell	PT (root and final pass) and multi-layer PT (if UT is not performed).	ASME Section V, Article 6 (PT)	PT: ASME Section III, Subsection NB, Article NB-5350
	PT (surface following pressure test) UT (if multi-layer PT is not performed)	ASME Section V, Article 5 (UT)	UT: ASME Section III, Subsection NB, Article NB-5332
Closure ring-to-shell	PT (final pass)	ASME Section V, Article 6 (PT)	PT: ASME Section III, Subsection NB, Article NB-5350
Closure ring-to-lid	PT (final pass)	ASME Section V, Article 6 (PT)	PT: ASME Section III, Subsection NB, Article NB-5350
Closure ring radial welds	PT (final pass)	ASME Section V, Article 6 (PT)	PT: ASME Section III, Subsection NB, Article NB-5350
Port cover plates-to-lid	PT (root and final pass)	ASME Section V, Article 6 (PT)	PT: ASME Section III, Subsection NB, Article NB-5350
Lift lug and lift lug baseplate	PT (surface)	ASME Section V, Article 6 (PT)	PT: ASME Section III, Subsection NG, Article NG-5350
Vent and drain port cover plate plug welds	PT (surface)	ASME Section V, Article 6 (PT)	PT: ASME Section III, Subsection NG, Article NG-5350

HOLTEC INTERNATIONAL COPYRIGHTED MATERIAL

Table 9.1.4 (continued)
 HI-STORM 100 NDE REQUIREMENTS

HI-STORM OVERPACK			
Weld Location	NDE Requirement	Applicable Code	Acceptance Criteria (Applicable Code)
N/A	N/A	N/A	N/A
HI-TRAC TRANSFER CASK			
Weld Location	NDE Requirement	Applicable Code	Acceptance Criteria (Applicable Code)
HI-TRAC Body: Radial ribs and short ribs to outer shell	PT (surface) or MT	ASME Section V, Article 6 (PT) ASME Section V, Article 7 (MT)	PT: ASME Section III, Subsection NF, Article NF-5350 MT: ASME Section III, Subsection NF, Article NF-5340
HI-TRAC Body: Water jacket end plate-to-radial channel or enclosure shell panel	PT (surface) or MT	ASME Section V, Article 6 (PT) ASME Section V, Article 7 (MT)	PT: ASME Section III, Subsection NF, Article NF-5350 MT: ASME Section III, Subsection NF, Article NF-5340
Pool Lid: Pool lid top plate-to-pool lid outer ring	PT (surface) or MT	ASME Section V, Article 6 (PT) ASME Section V, Article 7 (MT)	PT: ASME Section III, Subsection NF, Article NF-5350 MT: ASME Section III, Subsection NF, Article NF-5340
Pool Lid: Pool lid bottom plate-to-pool lid outer ring	PT (surface) or MT	ASME Section V, Article 6 (PT) ASME Section V, Article 7 (MT)	PT: ASME Section III, Subsection NF, Article NF-5350 MT: ASME Section III, Subsection NF, Article NF-5340

Table 9.1.4 (continued)
 HI-STORM 100 NDE REQUIREMENTS

HI-TRAC TRANSFER CASK			
Weld Location	NDE Requirement	Applicable Code	Acceptance Criteria (Applicable Code)
HI-TRAC Body: Water jacket end plate-to-outer shell	PT (surface) or MT	ASME Section V, Article 6 (PT) ASME Section V, Article 7 (MT)	PT: ASME Section III, Subsection NF, Article NF-5350 MT: ASME Section III, Subsection NF, Article NF-5340
HI-TRAC Body: Outer shell-to-outer shell longitudinal and circumferential welds	PT (surface) or MT	ASME Section V, Article 6 (PT) ASME Section V, Article 7 (MT)	PT: ASME Section III, Subsection NF, Article NF-5350 MT: ASME Section III, Subsection NF, Article NF-5340
HI-TRAC Body: Radial ribs and short ribs -to-enclosure shell panel	PT (surface) or MT	ASME Section V, Article 6 (PT) ASME Section V, Article 7 (MT)	PT: ASME Section III, Subsection NF, Article NF-5350 MT: ASME Section III, Subsection NF, Article NF-5340
HI-TRAC Body: Jacket drain pipe and couplings	PT (surface) or MT	ASME Section V, Article 6 (PT) ASME Section V, Article 7 (MT)	PT: ASME Section III, Subsection NF, Article NF-5350 MT: ASME Section III, Subsection NF, Article NF-5340
HI-TRAC Body: Outer shell-to-bottom flange	PT (surface) or MT	ASME Section V, Article 6 (PT) ASME Section V, Article 7 (MT)	PT: ASME Section III, Subsection NF, Article NF-5350 MT: ASME Section III, Subsection NF, Article NF-5340

Table 9.1.4 (continued)
HI-STORM 100 NDE REQUIREMENTS

HI-TRAC TRANSFER CASK			
Weld Location	NDE Requirement	Applicable Code	Acceptance Criteria (Applicable Code)
HI-TRAC Body: Outer shell-to-top flange	PT (surface) or MT	ASME Section V, Article 6 (PT) ASME Section V, Article 7 (MT)	PT: ASME Section III, Subsection NF, Article NF-5350 MT: ASME Section III, Subsection NF, Article NF-5340
HI-TRAC Body: Lifting trunnion block-to-top flange	PT (surface) or MT	ASME Section V, Article 6 (PT) ASME Section V, Article 7 (MT)	PT: ASME Section III, Subsection NF, Article NF-5350 MT: ASME Section III, Subsection NF, Article NF-5340
HI-TRAC Body: Lifting trunnion block-to-outer and inner shells	PT (surface) or MT	ASME Section V, Article 6 (PT) ASME Section V, Article 7 (MT)	PT: ASME Section III, Subsection NF, Article NF-5350 MT: ASME Section III, Subsection NF, Article NF-5340
HI-TRAC Body: Pocket trunnion-to-outer shell (HI-TRAC 125 and 100 only)	PT (surface) or MT	ASME Section V, Article 6 (PT) ASME Section V, Article 7 (MT)	PT: ASME Section III, Subsection NF, Article NF-5350 MT: ASME Section III, Subsection NF, Article NF-5340
HI-TRAC Body: Top lid welds except as noted on applicable drawings	PT (surface) or MT	ASME Section V, Article 6 (PT) ASME Section V, Article 7 (MT)	PT: ASME Section III, Subsection NF, Article NF-5350 MT: ASME Section III, Subsection NF, Article NF-5340
HI-TRAC Body: Pocket trunnion-to-enclosure shell panel and radial rib (HI-TRAC 125 and 100 only)	PT (surface) or MT	ASME Section V, Article 6 (PT) ASME Section V, Article 7 (MT)	PT: ASME Section III, Subsection NF, Article NF-5350 MT: ASME Section III, Subsection NF, Article NF-5340

Table 9.1.4 (continued)
HI-STORM 100 NDE REQUIREMENTS

HI-TRAC TRANSFER CASK			
Weld Location	NDE Requirement	Applicable Code	Acceptance Criteria (Applicable Code)
HI-TRAC Body: Lower water jacket welds	PT (surface) or MT	ASME Section V, Article 6 (PT) ASME Section V, Article 7 (MT)	PT: ASME Section III, Subsection NF, Article NF-5350 MT: ASME Section III, Subsection NF, Article NF-5340
HI-TRAC Body: Gusset-to-baseplate, outer shell and water jacket bottom plate (HI-TRAC 100D and 125D only)	PT (surface) or MT	ASME Section V, Article 6 (PT) ASME Section V, Article 7 (MT)	PT: ASME Section III, Subsection NF, Article NF-5350 MT: ASME Section III, Subsection NF, Article NF-5340
Transfer Lid: Lid intermediate plate and lead cover plate-to-lid top plate & lid bottom plate	PT (surface) or MT	ASME Section V, Article 6 (PT) ASME Section V, Article 7 (MT)	PT: ASME Section III, Subsection NF, Article NF-5350 MT: ASME Section III, Subsection NF, Article NF-5340
Transfer Lid: Door top plate-to-door wheel housing	PT (surface) or MT	ASME Section V, Article 6 (PT) ASME Section V, Article 7 (MT)	PT: ASME Section III, Subsection NF, Article NF-5350 MT: ASME Section III, Subsection NF, Article NF-5340
Transfer Lid: Door side plate-to-door wheel housing	PT (surface) or MT	ASME Section V, Article 6 (PT) ASME Section V, Article 7 (MT)	PT: ASME Section III, Subsection NF, Article NF-5350 MT: ASME Section III, Subsection NF, Article NF-5340
Transfer Lid: Door side plate-to-door end plate	PT (surface) or MT	ASME Section V, Article 6 (PT) ASME Section V, Article 7 (MT)	PT: ASME Section III, Subsection NF, Article NF-5350 MT: ASME Section III, Subsection NF, Article NF-5340
Transfer Lid: Lead cover plate-to-lead cover side plate	PT (surface) or MT	ASME Section V, Article 6 (PT) ASME Section V, Article 7 (MT)	PT: ASME Section III, Subsection NF, Article NF-5350 MT: ASME Section III, Subsection NF, Article NF-5340

HOLTEC INTERNATIONAL COPYRIGHTED MATERIAL

9.2 MAINTENANCE PROGRAM

An ongoing maintenance program shall be defined and incorporated into the HI-STORM 100 System Operations Manual, which shall be prepared and issued prior to the delivery and first use of the system to each user. This document shall delineate the detailed inspections, testing, and parts replacement necessary to ensure continued structural, thermal, and confinement performance; radiological safety, and proper handling of the system in accordance with 10CFR72 regulations, the conditions in the Certificate of Compliance, and the design requirements and criteria contained in this FSAR.

The HI-STORM 100 System is totally passive by design. There are no active components or monitoring systems required to assure the performance of its safety functions. As a result, only minimal maintenance will be required over its lifetime, and this maintenance would primarily result from weathering effects in storage. Typical of such maintenance would be the reapplication of corrosion inhibiting materials on accessible external surfaces. Visual inspection of the vent screens is required to ensure the air inlets and outlets are free from obstruction (or alternatively, temperature monitoring may be utilized). Such maintenance requires methods and procedures no more demanding than those currently in use at power plants.

Maintenance activities shall be performed under the licensee's NRC-approved quality assurance program. Maintenance activities shall be administratively controlled and the results documented. The maintenance program schedule for the HI-STORM 100 System is provided in Table 9.2.1.

9.2.1 Structural and Pressure Parts

Prior to each fuel loading, a visual examination in accordance with a written procedure shall be required of the HI-TRAC lifting trunnions and pocket trunnion recesses. The examination shall inspect for indications of overstress such as cracking, deformation, or wear marks. Repairs or replacement in accordance with written and approved procedures shall be required if unacceptable conditions are identified.

Testing to verify continuing compliance of the transfer cask trunnions shall be performed in accordance with ANSI N14.6-1993.

As described in FSAR Chapters 7 and 11, there are no credible normal, off-normal, or accident events which can cause the structural failure of the MPC. Therefore, periodic structural or pressure tests on the MPCs following the initial acceptance tests are not required as part of the storage maintenance program.

9.2.2 Leakage Tests

There are no seals or gaskets used on the fully-welded MPC confinement system. As described in Chapters 7 and 11, there are no credible normal, off-normal, or accident events which can cause the failure of the MPC confinement boundary welds. Therefore, leakage tests are not required as part of

HOLTEC INTERNATIONAL COPYRIGHTED MATERIAL

the storage maintenance program.

9.2.3 Subsystem Maintenance

The HI-STORM 100 System does not include any subsystems, which provide auxiliary cooling. Normal maintenance and calibration testing will be required on the vacuum drying, helium backfill, and leakage testing systems. Rigging, remote welders, cranes, and lifting beams shall also be inspected prior to each loading campaign to ensure proper maintenance and continued performance is achieved. Auxiliary shielding provided during on-site transfer operations with the HI-STORM 100 require no maintenance. If the cask user chooses to use an air temperature monitoring system in lieu of visual inspection of the air inlet and outlet vents, the thermocouples and associated temperature monitoring instrumentation shall be maintained and calibrated in accordance with the user's QA program commensurate with the equipment's safety classification and designated QA category. See also FSAR Section 9.2.6.

9.2.4 Pressure Relief Valves

The pressure relief valves used on the water jackets for the HI-TRAC transfer cask shall be calibrated on an annual basis (or prior to the next HI-TRAC use if the period the HI-TRAC is out of use exceeds one year) to ensure pressure relief settings are 60 +2/-0 psig and 65 +2/-0 psig, or replaced with factory-set relief valves.

9.2.5 Shielding

The gamma and neutron shielding materials in the HI-STORM overpack, HI-TRAC; and MPC degrade negligibly over time or as a result of usage.

Radiation monitoring of the ISFSI by the licensee in accordance with 10CFR72.104(c) provides ongoing evidence and confirmation of shielding integrity and performance. If increased radiation doses are indicated by the facility monitoring program, additional surveys of overpacks shall be performed to determine the cause of the increased dose rates.

The water level in the HI-TRAC water jacket shall be verified during each loading campaign in accordance with the licensee's approved operations procedures.

The neutron absorber panels installed in the MPC baskets are not expected to degrade under normal long-term storage conditions. The use of Boral in similar nuclear applications is discussed in Chapter 1, and the long-term performance in a dry, inert gas atmosphere is evaluated in Chapter 3. A similar discussion is provided for METAMIC[®] neutron absorber material. Therefore, no periodic verification testing of neutron poison material is required on the HI-STORM 100 System.

9.2.6 Thermal

In order to assure that the HI-STORM 100 System continues to provide effective thermal performance during storage operations, surveillance of the air vents (or alternatively, by temperature monitoring) shall be performed in accordance with written procedures.

For those licensees choosing to implement temperature monitoring as the means to verify overpack heat transfer system operability, a maintenance and calibration program shall be established in accordance with the plant-specific Quality Assurance Program, the equipment's quality category, and manufacturer's recommendations.

Table 9.2.1

HI-STORM SYSTEM MAINTENANCE PROGRAM SCHEDULE

Task	Frequency
Overpack cavity visual inspection	Prior to fuel loading
Overpack bolt visual inspection	Prior to installation during each use
Overpack external surface (accessible) visual examination	Annually, during storage operation
Overpack vent screen visual inspection for damage, holes, etc.	Monthly
HI-STORM 100 Shielding Effectiveness Test	In accordance with Technical Specifications after initial fuel loading
HI-TRAC cavity visual inspection	Prior to each handling campaign
HI-TRAC lifting trunnion and pocket trunnion recess visual inspection	Prior to each handling campaign
Testing to verify continuing compliance of HI-TRAC Lifting Trunnions	In accordance with ANSI N14.6-1993
HI-TRAC pressure relief valve calibration	Annually [†]
HI-TRAC internal and external visual inspection for compliance to design drawings	Annually [†]
HI-TRAC water jacket water level visual examination	During each handling campaign in accordance with licensee approved operations procedures
Overpack visual inspection of identification markings	Annually
Overpack Air Temperature Monitoring System	Per licensee's QA program and manufacturer's recommendations

[†] Or prior to next HI-TRAC use if the period the HI-TRAC is out of use exceeds one year.

9.3 REGULATORY COMPLIANCE

Chapter 9 of this FSAR has been prepared to summarize the commitments of Holtec International to design, construct, and test the HI-STORM 100 System in accordance with the Codes and Standards identified in Chapter 2. Completion of the defined acceptance test program for each HI-STORM 100 System will provide assurance that the SSCs important to safety will perform their design function. The performance of the maintenance program by the licensee for each loaded HI-STORM 100 System will provide assurance for the continued safe long-term storage of the stored SNF.

The described acceptance criteria and maintenance programs can be summarized in the following evaluation statements:

1. Section 9.1 of this FSAR describes Holtec International's proposed program for pre-operational testing and initial operations of the HI-STORM 100 System. Section 9.2 describes the proposed HI-STORM 100 maintenance program.
2. Structures, systems, and components (SSCs) of the HI-STORM 100 System designated as important to safety will be designed, fabricated, erected, assembled, inspected, tested, and maintained to quality standards commensurate with the importance to safety of the function they are intended to perform. Tables 2.2.6 and 8.1.6 of this FSAR identify the safety importance and quality classifications of SSCs of the HI-STORM 100 System and its ancillary equipment, respectively. Tables 2.2.6 and 2.2.7 present the applicable standards for their design, fabrication, and inspection of the HI-STORM 100 System components.
3. Holtec International will examine and test the HI-STORM 100 System to ensure that it does not exhibit any defects that could significantly reduce its confinement effectiveness. Section 9.1 of this FSAR describes the MPC confinement boundary assembly, inspection, and testing.
4. Holtec International will mark the cask with a data plate indicating its model number, unique identification number, and empty weight.
5. It can be concluded that the acceptance tests and maintenance program for the HI-STORM 100 System are in compliance with 10CFR72 [9.0.1], and that the applicable acceptance criteria have been satisfied. The acceptance tests and maintenance program will provide reasonable assurance that the HI-STORM 100 System will allow safe storage of spent fuel throughout its certified term. This can be concluded based on a review that considers the regulation itself, appropriate regulatory guides, applicable codes and standards, and accepted practices.

9.4 REFERENCES

- [9.0.1] U.S. Code of Federal Regulations, Title 10, "Energy", Part 72, "Licensing Requirements for the Independent Storage of Spent Nuclear Fuel and High-Level Radioactive Waste".
- [9.0.2] NUREG-1536, "Standard Review Plan for Dry Cask Storage Systems", January 1997.
- [9.1.1] American Society of Mechanical Engineers, "Boiler and Pressure Vessel Code," Sections II, III, V, IX, and XI, 1995 Edition, including Addenda through 1997.
- [9.1.2] American Society for Nondestructive Testing, "Personnel Qualification and Certification in Nondestructive Testing," Recommended Practice No. SNT-TC-1A, December 1992.
- [9.1.3] American National Standards Institute, Institute for Nuclear Materials Management, "American National Standard for Radioactive Materials - Special Lifting Devices for Shipping Containers Weighing 10,000 Pounds (4500 kilograms) or More", ANSI N14.6, September 1993.
- [9.1.4] NUREG-0612, "Control of Heavy Loads at Nuclear Power Plants", U.S. Nuclear Regulatory Commission, Washington, D.C., July 1980.
- [9.1.5] American National Standards Institute, Institute for Nuclear Materials Management, "American National Standard for Radioactive Materials Leakage Tests on Packages for Shipment", ANSI N14.5, January 1997.
- [9.1.6] Holtec International Position Paper DS-213, "Acceptable Flaw Size in MPC Lid-to-Shell Welds", Revision 2.

SUPPLEMENT 9.I

ACCEPTANCE CRITERIA AND MAINTENANCE PROGRAM FOR THE HI-STORM 100U SYSTEM

9.I.0 INTRODUCTION

This supplement addresses fabrication, inspection, test, and maintenance program for the HI-STORM 100U VVM. The HI-STORM 100U System does not require any changes to the acceptance criteria or maintenance requirements for the MPC or the HI-TRAC transfer cask. Therefore, the material on the fabrication, maintenance, testing, and inspection of all components contained in the main body of this chapter remains unchanged and applicable.

The VVM consists of a shop-fabricated CEC (Cavity Enclosure Container) installed below grade and a removable Closure Lid. The CEC is a welded shell-type structure made of low carbon steel plate and bar (or forging) stock. Likewise, the Closure Lid is made of welded and formed steel plates. However, unlike the CEC, the Closure Lid also contains shielding concrete.

By virtue of its underground configuration, the CEC is interfaced by the subgrade along its lateral surface by the top surface pad near its flanged upper region and by the support foundation along its bottom surface. The requirements on these interfacing bodies to the extent they are needed to enable the CEC to render its intended function are provided in Supplement 2.I. All requirements pertaining to the manufacturing, inspection, testing, and maintenance of the VVM SSCs are presented in this supplement to comply with the provisions of 10CFR71.24(p).

9.I.1 ACCEPTANCE CRITERIA

The design, fabrication, inspection, and testing of the VVM is performed in accordance with the applicable codes and standards specified in Supplement 2.I and on the drawing. Acceptance criteria described in FSAR Section 9.1 for the overpack are also implemented for the HI-STORM 100U VVM, as applicable, and as further particularized below.

9.I.1.1 Manufacturing of VVM Components

The manufacturing of VVM components shall be carried out in accordance with the CoC holder's NRC-approved QA program. All elements of the manufacturing cycle will be established to accord with the Important-to-Safety (ITS) designation of the specific part and the applicable provisions of the referenced codes and standards. The acceptance criteria for the manufactured components apply to each step of the manufacturing evolution, namely (a) supplier selection, (b) preparation of material procurement specifications, (c) preparation of the shop traveler and fabrication procedures, (d) fabrication activities such as forming, bending, plasma cutting, and welding, (e) in-process inspections, (f) final inspection, (g) packaging for shipment, and (h) assembling of the documentation package to serve as the archival evidence of adherence to the quality requirements.

HOLTEC INTERNATIONAL COPYRIGHTED MATERIAL

9.1.1.2 Site Construction

Like the aboveground HI-STORM overpacks, the site construction activities on the VVM and its interfacing SSCs (namely, the foundation, the subgrade, and the top surface pad) shall be carried out to demonstrate compliance with the technical criteria set forth in this FSAR. The specific requirements, to ensure that the required *critical characteristics** of the VVM and the interfacing SSCs are realized, are summarized below.

- a. All site construction processes shall be procedurized, reviewed, and approved in accordance with the CoC holder's NRC-approved QA program.
- b. Although the ITS designations apply to VVM components only, all interfacing SSCs (except for concrete encasement and cathodic protection system) shall also be designated as ITS Category C to ensure that the construction materials and processes will be subject to the necessary quality assurance regimen.
- c. Compliance with the requirements in this FSAR shall be demonstrated by appropriate testing and the results documented for archival reference. For example, the strength properties of the subgrade can be established using the classical "plate test".
- d. The shielding concrete shall comply with the applicable provisions of Appendix I.D.
- e. The insulation installed on the Divider Shell shall be subject to visual examination to ensure that it is undamaged and properly secured.
- f. The coating on the exterior surface of the CEC shall be inspected for absence of damage before the surface becomes inaccessible.
- g. The impressed current cathodic protection system (ICCPS), if used, shall be installed in accordance with the applicable guidelines referenced in Supplement 3.I, Subsection 3.I.4.
- h. The concrete encasement, if used, shall be installed in accordance with the requirements of Supplement 3.I, Subsection 3.I.4.
- i. The dimensional compliance of the CEC, including its verticality, shall be inspected to establish compliance with the governing construction documents.

* See Glossary for definition.

- j. The installation of the corrosion barriers shall be in accordance with written procedures.
- k. All VVM surfaces that become inaccessible shall be photographed with sufficient resolution to provide a clear archive of their in-situ state at installation.

The governing processes for manufacturing control shall be prepared to be in complete compliance with this FSAR. For example, the dimensions of the HI-STORM 100U VVM steel components and the properties of the shielding concrete shall be verified to be in accordance with FSAR Supplement 2.I, Appendix 1.D (as applicable), and the drawings prior to concrete placement. The dimensional inspection and density measurements shall be documented.

The governing NDE references provided for the aboveground HI-STORM overpack in Table 9.1.4 also apply to the VVM, as do the requirements on the documentation package contents specified in paragraph 9.1.1(13).

In order to receive the Certificate-of-Compliance under the CoC holder's QA program, the manufacturing of the VVM components must meet all of the technical, quality control, procedural (quality assurance) and administrative requirements set forth in the manufacturing program.

Similarly, the low carbon steel plates, bars, and forgings, as applicable, used in the construction of the HI-STORM 100U VVM shall be dimensionally inspected to assure compliance with the requirements on the drawings. Test results shall be documented and become part of the quality documentation package. Dimensional inspections of the Closure Lid and its weight measurement after placement in the shielding concrete shall assure that the required amount of shielding material has been incorporated in the lid.

9.1.1.3 Inspections and Testing

i. Post-Construction Inspection:

Each as-built VVM shall be inspected for final acceptance before it is loaded with fuel. The following inspections define minimum acceptance requirements:

- a. The as-installed Divider Shell shall be inspected to ensure that it sits on the Bottom Plate and is flanked by lateral and circumferential guides located in the bottom region of the CEC. The top surface elevation and roundness of the Divider Shell shall be inspected to ensure it will not hinder installation of the Closure Lid.
- b. The Container Flange and Divider Shell gasket/seal bearing surfaces shall be inspected for their horizontal alignment (within specified tolerance).

- c. The Restraint Ring welded to the underside of the Closure Lid shall be checked for fitup with the Container Flange.
- d. The inlet and outlet air passages in the Closure Lid shall be inspected for absence of obstruction such as debris and extensive weld spatter.
- e. The results of the post-construction inspection shall be incorporated in the VVM's Documentation Package.
- f. The impressed current cathodic protection system (ICCP), if used, shall be tested in accordance with the applicable guidelines referenced in Supplement 3.I, Subsection 3.I.4.

ii. Shielding Integrity and Effectiveness Test

The effectiveness tests performed during fabrication and operation of the HI-TRAC remains the same as in the aboveground system, as described in 9.1.5.2. The 100U VVM is unique however since the gamma and neutron shielding are provided by the concrete and steel components of the VVM as well as by the surrounding subgrade and the top surface pad.

As shown in Supplement 5.I, the shielding performance of the HI-STORM 100U system is significantly better than its aboveground counterparts. Further, the long-term shielding effectiveness in the HI-STORM 100U system is also assured to an extremely high level of confidence by virtue of its physical configuration, choice of materials, and design embodiment, as described below:

- a. Absence of penetrations in the VVM body: The CEC has no penetrations and thus has no path that can serve as a conduit for radiation streaming. All penetrations are in the lid and are configured to maximize scattering of photons and neutrons.
- b. Axisymmetric penetrations in the lid: As shown in the drawings, all penetrations in the lid are axisymmetric. In particular, the air inlet passage is formed by narrowly separated steel plates that girdle the lid, allowing only infinitesimal amounts of neutrons and gamma radiation to the outside. Likewise, the outlet air passage is formed by a set of formed surfaces of revolution that preclude a direct "line-of-sight" from the fuel to the outside. Because these air passages are formed by welded steel shapes, they will remain invariant over time, making their shielding performance reliably constant over years of use.
- c. Aging of foundation, subgrade: Even though a very stiff support foundation is specified, some settlement of the foundation is expected. However, any settlement of the foundation would have no deleterious effect on the extent of shielding to the environment.

Second, while the subgrade is unloaded, except when a transporter is passing over it, some settlement of the subgrade and the above top surface pad is expected. Any subgrade settlement, however, will result in a corresponding compaction of its material, which will improve the subgrade's shielding capability. The settlement of the subgrade will not result in any new loading on the CEC structure (which is autonomously supported on the foundation) or the Closure Lid, which is autonomously supported on the CEC structure. Any visible gap or crevice between the Container Flange and the surface pad should be filled with grout or caulking for both aesthetic purposes and enhancement of degradation and corrosion mitigation.

- d. **Effect of Corrosion:** It can be readily deduced from the VVM's design that the only surfaces that are not accessible for corrosion monitoring are the bottom face and outer surface of the CEC. As discussed in Supplement 3.I, corrosion mitigation measures for these surfaces are prescribed and expected to provide adequate corrosion mitigation for decades beyond the Design Life of the VVM. These corrosion mitigation measures, however, are chiefly required to preserve long-term structural, not shielding, integrity of the CEC because the effect of the CEC shell or Bottom Plate corrosion on the dose to the environment is ostensibly miniscule.

Thus, the potential for reduction in the shielding effectiveness of the HI-STORM 100U system due to corrosion is not a concern.

- e. **Water Intrusion:** Because the underground portion of the HI-STORM 100U VVM contains a thick steel shell structure without any penetrations, intrusion of ground water in the MPC storage cavity is not credible. At some sites, ground water may saturate the surrounding subgrade. A water-saturated subgrade, however, will be more effective (not less) in radiation attenuation and, therefore, seepage of ground water around the HI-STORM 100U vertical space will not threaten loss in its shielding integrity.
- f. **Materials of Construction:** The sole material of construction in the underground portion of the CEC is carbon steel (the optional concrete encasement is not credited in the shielding evaluation), which is a proven material of long-term shielding endurance under fluence levels that are orders of magnitude greater than those present in the CEC. The Closure Lid is comprised of low carbon steel that encases plain concrete. Concrete, like steel, is a proven durable material in a radiation environment that suffers negligible change in its shielding capability over long periods of use in a radiation environment. Therefore, material degradation induced reduction in the shielding effectiveness of the VVM is not a credible concern.

The long-term shielding effectiveness of the HI-STORM 100U is assured by virtue of its design configuration and its constituent materials.

However, to verify the VVM's shielding capability, operational neutron and gamma shielding effectiveness tests, (i.e. radiation surveys), shall be performed similar to those described in Subsection 9.1.5.2 for the aboveground systems. The tests will be performed after fuel loading using written and approved procedures. Calibrated neutron and gamma dose rate meters shall be used to measure the dose rates at the top of the VVM and at the vents, consistent with the Radiation Protection Program. The tests are considered acceptable if the dose rates are less than or equal to the calculated limits. If dose rates are higher than the limits, the required actions provided in the Radiation Protection Program shall be completed. Dose rate measurements shall be documented and become a part of the quality documentation package.

iii. Thermal Acceptance Test

The thermal acceptance test is performed as described in Subsection 9.1.6 for the aboveground systems.

9.1.1.4 Cask Identification

The MPC and HI-TRAC transfer cask are identified as described in Subsection 9.1.7. See Subsection 9.1.3 for discussion of identification requirements for the VVM.

9.1.1.5 Storm Water Control Test

The VVM is designed to direct storm water and snow/ice melt-off away from the Closure Lid where the air passages are located. Any minor amount of moisture that may intrude into the MPC cavity due to wind-driven rain will evaporate in a short period of time due to the movement of heated air in the MPC storage cavity. To verify the effectiveness of the storm water drainage design, a one-time test shall be performed after construction of the first VVM to ensure that the design is effective in directing storm water away from the VVM to the ISFSI's drainage system. The VVM shall be subjected to a water spray that simulates exposure to rainfall of at least 2 inches per hour for at least one hour. At the conclusion of the water spray, the depth of the water (if any) in the bottom of the module cavity shall be measured. Any amount of water accumulation beyond wetting of the Bottom Plate indicates an inadequacy in rain diversion features of the VVM and shall be appropriately corrected. It should be noted that, as stated in Supplement 4.I, any amount of accumulated water in the CEC will not cause any component of the HI-STORM 100U System to exceed its regulatory limit as supported by Supplement 4.I. The only deleterious effect of water is the potential for increased preservative degradation (on the wetted surface of the Bottom Plate, CEC shell and other interfacing components) from prolonged exposure.

9.1.1.6 Inspection Criteria

The inspection and test criteria specified in FSAR Table 9.1.2 shall be implemented for the VVM to the extent they are applicable. No additional inspections or tests other than those specified in this supplement are required. Consistent with Table 9.1.4, no non-destructive examination (NDE) beyond visual examination is required for the VVM steel components.

9.1.2 MAINTENANCE PROGRAM

9.1.2.1 HI-STORM 100U System

The HI-STORM 100U System is totally passive by design and requires minimal normal maintenance to ensure it can perform its design functions. Periodic surveillance (via temperature monitoring or visual or camera-aided inspection of air passages) is required to ensure that the air passages in the lid are not blocked. Preventive or remedial painting of the exposed steel surfaces as part of the user's preventive maintenance program is recommended to mitigate corrosion. Such preventive maintenance activities are typical in scope and complexity to other standard maintenance activities at nuclear power plants. Maintenance activities described in FSAR Section 9.2 and Table 9.2.1 shall be implemented for other HI-STORM 100U System components, namely, the MPC and the HI-TRAC transfer cask, without any change.

The maintenance requirements on the VVM also parallel those for the aboveground HI-STORM overpack, but are slightly different. In the following, the essentials of the maintenance program for VVM are specified. Because the VVM is a passive structure and is largely protected from the weather due to its underground configuration, the maintenance requirements on it are rather minimal. Nevertheless, a carefully articulated preventive maintenance program is essential for a satisfactory service life.

In-service inspection for long-term interior and below-grade degradation shall be performed on a site-specific basis in accordance with Holtec prepared long-term maintenance guidelines and the licensee's preventive maintenance program. At most potential ISFSI sites, visual inspection of accessible areas of the VVM is expected to be sufficient to evaluate long-term degradation. The frequency of this visual in-service inspection should be in performed in accordance with Table 9.1.1. Additional in-service inspection activities may include more thorough inspections for foreign material accumulation, corrosion (CEC wall thinning) and insulation degradation as warranted by site-specific conditions. One example is ultrasonic inspection of the CEC using a remotely operated device to check for wall thinning. VVM Closure Lid removal or even MPC transfer into a HI-TRAC may be necessary for certain inspections. For certain inspections such as evaluating CEC wall thinning, a sampling of VVMs at a given ISFSI array may be used but should be commensurate with previous inspection results. The frequencies for the additional in-service inspection activities will be determined on a site-specific basis and may include allowance to increase or decrease the frequency commensurate with the results of previous inspections. In-service inspections for evaluating foreign material accumulation, corrosion (CEC wall thinning) and/or insulation degradation are not required if it is determined that the applicable degradation mechanisms do not exist. For defense in depth, VVM ISFSIs not employing impressed current cathodic protection shall be subject to a mandatory visual and UT

inspection of at least one representative VVM to check for wall thinning and pitting of the CEC at an interval not to exceed 20 years. The inspections are performed on the inside surface of the CEC. The VVM chosen for inspection is not required to be in use or to have previously contained a loaded MPC. A VVM with a loaded MPC may be inspected using remote devices with the VVM lid removed. The oldest VVM or VVM considered to be most vulnerable to corrosion degradation shall be selected for inspection.

As is true for all components certified pursuant to this FSAR, the maintenance activities on the HI-STORM 100U VVM shall be performed in accordance with a written program that fulfills the requirements of the CoC holder's 10CFR72 Subpart G compliant QA program, the owner site's Safety Plan and corrective action program; and the system's Technical Specification.

Among the QA commitments are performance of maintenance by trained personnel by written procedures; and, written documentation of the maintenance work performed and of the results obtained. Table 9.I.1 provides a listing of the minimum maintenance activities on the HI-STORM 100U VVM.

9.I.2.2 Subsystem Maintenance

No new ancillary equipment or sub-systems requiring periodic maintenance are required for use of the HI-STORM 100U System.

9.I.2.3 Shielding

As discussed in the foregoing, the radiation shielding capacity of the HI-STORM 100U System is expected to degrade negligibly over time. Therefore, unless the VVM is subjected to an extreme environmental event that imparts stresses or temperatures beyond the design basis limits for the system (i.e., prolonged fire or impact from a beyond-the-design basis large energetic projectile) such that this event could potentially degrade the shielding effectiveness of the VVM, no shielding effectiveness tests beyond that required by the Radiation Protection Program are required over the life of the HI-STORM 100U System.

9.I.3 REGULATORY COMPLIANCE

The information presented in this supplement augments the material in the main body of the chapter to fulfill the regulatory requirements pertaining to the testing and maintenance of the HI-STORM 100U System, resolution of issues concerning adequacy and reliability, and cask identification. Section 9.3 of this FSAR provides the necessary information on all HI-STORM system components except the VVM. This section demonstrates the corresponding compliance information on the VVM.

- a. The program for pre-operational testing and initial operations, as required by 10CFR72.24(p) for the VVM, is provided in Section 9.I.1 herein.

- b. The maintenance protocol for the VVM, as specified in §72.236(g), is provided in Section 9.I.2 herein.
- c. The quality assurance requirements on the design, fabrication, on-site construction of the VVM commensurate with its ITS designation are invoked through Chapter 13 of this FSAR and are summarized in Section 9.I.1 herein, as called for in §72.122(a), §72.122(f), §72.128(a)(1) and §72.24(c).
- d. The provisions of §72.82(c) with respect to acceptance criteria and the appropriate test program to ensure compliance with the acceptance criterion are fulfilled by Section 9.I.1 herein.
- e. The quality requirements with respect to inspection, testing, and documentation, as set down in §72.212(b)(8), are provided in Section 9.I.1 herein.
- f. The VVM, except for its Closure Lid, does not require unique marking other than that required for fuel ISFSI configuration management because it is not a transportable structure. The module is essentially an integral portion of the ISFSI, not a separate cask structure that can be moved by the user. As such, the markings provided on the MPC alone are sufficient to meet the requirements of 10CFR72.236(k). Nevertheless, it is required that each VVM cavity be labeled with an identifier that is unique for the specific site. Further, because the Closure Lid will be subject to handling, consistent with defense-in-depth guidelines for handling heavy loads at nuclear plants, its unique identifier and its bounding weight shall be permanently marked on a readily visible location.

Table 9.I.1: Maintenance Activities for the HI-STORM 100U VVM*			
	Activity	Frequency	Comment
1.	CEC cavity is visually inspected	Prior to MPC installation	To ensure that VVM internal components are properly aligned, the surface preservatives on all exposed surfaces are undamaged, the insulation on the Divider Shell is undamaged and the cavity is free of visible foreign material.
2.	Lid Examination	Prior to MPC installation	Ensure that the preservatives on the external surfaces are in good condition and the lid is free of dents and rust stains.
3.	Screen Inspection	Prior to installation of the flanged screen assembly and monthly when in use	Ensure that the screen is undamaged.
4.	Interfacing SSCs	Annually	Ensure that the top surface pad is free of visible cracks, the interface between the top surface pad and the Container Flange is grouted (or caulked) if necessary, the ISFSI drain system is functional, the ground water system (if used) is in working order, and that subgrade settlement counter measures are implemented. The cathodic protection system is routinely verified as operable in accordance with the Bases in Chapter 12 for guidance on acceptance criteria.
5.	Shielding Effectiveness Test	As required by the Radiation Protection Program	—

* This table provides maintenance activities for the “100U” VVM that parallel those for HI-STORM overpacks in Table 9.2.1.

HOLTEC INTERNATIONAL COPYRIGHTED MATERIAL

HI-STORM FSAR
REPORT HI-2002444

9.I-10

Rev. 9

HI-STORM 100 FSAR, NON-PROPRIETARY
REVISION 12
MARCH 12, 2014

Table 9.I.1: Maintenance Activities for the HI-STORM 100U VVM*			
	Activity	Frequency	Comment
6.	ISFSI Settlement	Every five years	Confirm that the VVM settlement is within the range of the Plant's "best estimate". Implement countermeasures if the settlement is determined to be excessive by the CoC holder.
7.	VVM Air Temperature Monitoring System (if used)	Per Licensee's QA Program and manufacturer's recommendations	—
8.	VVM In-Service Inspection	Annually	Ensure that the vent screen assembly fasteners remain coated with preservative, the screen is undamaged, all visible external surfaces are corrosion free, and the air passages are not degraded.
9.	<p>Additional VVM In-Service Inspection for Long-Term Interior and Below-grade Degradation:</p> <p>a) Visual inspection of accessible areas for long-term degradation.</p> <p>b) Additional in-service inspection activities include inspection for foreign material accumulation, corrosion (CEC thinning) and insulation degradation</p> <p>c) Visual and UT inspection for VVMs <u>not</u> employing impressed current cathodic protection</p>	<p>a) Monthly visual inspection of accessible areas.</p> <p>b) Frequencies for additional in-service inspections are determined on a site-specific basis.</p> <p>c) Visual and UT inspection at an interval not to exceed 20 years</p>	<p>Inspection activities shall be commensurate with site-specific conditions. Under site conditions existing at most ISFSI sites, visual inspection of accessible areas is sufficient to determine the general condition of the system.</p> <p>See Subsection 9.I.2.1 and Technical Specifications for more information.</p>

HOLTEC INTERNATIONAL COPYRIGHTED MATERIAL

HI-STORM FSAR
REPORT HI-2002444

9.I-11

Rev. 9

HI-STORM 100 FSAR, NON-PROPRIETARY
REVISION 12
MARCH 12, 2014

SUPPLEMENT 9.III

ACCEPTANCE CRITERIA AND MAINTENANCE PROGRAM FOR THE MPC-68M

9.III.0 INTRODUCTION

The main body of this chapter remains fully applicable for the HI-STORM 100 System using the MPC-68M model fuel basket (with existing MPC enclosure vessel) except as described below. Since the MPC-68M fuel basket is made entirely of Metamic-HT, the fabrication and inspection standards as well as the welding differ from the standard stainless steel baskets in the other MPC models. The MPC-68M model fuel basket is equipped with full length basket shims made entirely of aluminum alloy.

9.III.1 ACCEPTANCE CRITERIA

9.III.1.1 Fabrication and Non-Destructive Examination

The fabrication, inspection and testing on the MPC-68M fuel basket is performed in accordance with the following fabrication controls and required inspections and the drawing in Section 1.5.

1. Materials of construction specified for the MPC-68M fuel basket (including fuel basket and fuel basket shims) are identified in the drawing in Section 1.5. Metamic-HT panel material shall be procured with certification and supporting documentation as required in this FSAR supplement.
2. Structural/code welds shall be visually examined in accordance with ASME Section III, Division 1, Subsection NG, Article NG-5360.
3. Non-structural/non-code welds shall be visually examined in accordance with the drawing in Section 1.5.
4. Weld procedures and welder qualifications shall be in accordance with the drawing in Section 1.5.
5. Structural/code weld defects shall be removed in accordance with the requirements of the ASME Code, Section III, Subsection NG, Article NG-4450. Following defect removal, the area shall be MT or PT examined to the acceptance standards of ASME Subsection NG, NG-5300. The requirements for repair welds and subsequent re-inspection shall be the same as those required for the original weld.
6. Non-structural/non-code welds requiring weld repair shall be repaired in accordance with written and approved procedures developed specifically for welding Metamic-HT or basket shims as applicable and in accordance with ASME Section IX or AWS D1.2/D1.2M and examined after repair in the same manner as the original weld.

9.III.1.2 Structural and Pressure Tests

Structural and pressure tests for the HI-STORM 100 System are discussed in the main body of this chapter.

HOLTEC INTERNATIONAL COPYRIGHTED MATERIAL

9.III.1.3 Material Testing

Qualification tests on Metamic-HT specimens drawn from production runs shall be performed in compliance with Table 9.III.1 requirements to ensure that the manufactured panels shall render their intended function. Testing shall be performed using written and approved procedures consistent with the test methods documented in Holtec's test report [1.III.A.3].

To ensure the above test requirements are met a sampling plan based on the MIL Standard 105E [9.III.1] is defined and incorporated in the Metamic-HT Manufacturing Manual's Shop Operating Procedure HTSOP-108. The MIL Standard test protocols are selected to maximize coupon population. The test plan has the following key attributes:

1. At the start of the Metamic HT production runs at the manufacturing facility, the number of extrusions subjected to testing is based upon the Tier 1 sample population per Table 9.III.2 (Three coupons from each extrusion are needed to test the property data in Table 9.III.3).
2. If every one of the seven mechanical strength properties meets its respective MGTV value given in Table 9.III.3, then the subject lot of extrusions is determined to be acceptable.
3. If all tested coupons in five consecutive lots pass (i.e., each of the seven properties in Table 9.III.3 meets its MGTV requirement) then the required coupon population can drop down to the Tier 2 sample population per Table 9.III.2.
4. If all tested coupons in an additional five consecutive lots pass, then the required coupon population can drop down to the Tier 3 sample population per Table 9.III.2.
5. If all tested coupons in an additional ten consecutive lots pass, then the required coupon population can drop down to the Tier 4 sample population per Table 9.III.2.
6. If a coupon fails with respect to any property, then it can be replaced by two coupons from the slab that produced the failed coupon. If both of the replacement coupons pass all of the seven MGTV properties, then the lot can be accepted. If either of the replacement coupons fails to meet any of the seven properties, then the entire lot is rejected.
7. The failure of any coupons in a lot requires that subsequent sampling be conducted per the Tier 1 sample population per Table 9.III.2. A reduction to Tier 2, Tier 3, and Tier 4 sample populations in subsequent lots shall be based on the sampling plan described above.

Test results on all materials shall be documented and become part of the final quality documentation package.

9.III.1.4 Component Tests

Component tests for the HI-STORM 100 System are discussed in the main body of this chapter.

9.III.1.5 Shielding Integrity

The information in this section is moved to Section 9.III.2 below.

9.III.1.5.1 Neutron Absorber Manufacturing Requirements

The information in this section is moved to Section 9.III.2.1 below.

9.III.1.5.2 Neutron Absorber Manufacturing and Tests

The information in this section is moved to Section 9.III.2.2 below.

9.III.2 Shielding Integrity

9.III.2.1 Neutron Absorber Manufacturing Requirements

Essential characteristics of Metamic-HT are described in Appendix A of Supplement 1.III of this FSAR. The manufacturing of Metamic-HT is governed by a set of quality validated shop procedures contained in a Manufacturing Manual [1.III.A.4].

The key constituents of Metamic-HT, namely aluminum powder and Boron Carbide powder are procured under their respective purchasing specifications that define the required particle size distributions and set down the prohibited materials & impurities, as well as tolerable level of trace amounts of acceptable impurities.

As required by the procedures set down in its manufacturing manual [1.III.A.4], each panel of Metamic-HT neutron absorber material shall be visually inspected for damage such as scratches, cracks, burrs, presence of imbedded foreign materials, voids and discontinuities that could significantly affect its functional effectiveness.

Metamic-HT panels will be manufactured according to a Holtec purchase specification that incorporates all requirements set forth in this FSAR. The supplier of raw materials must be qualified under Holtec's quality program (or under Holtec subsidiary Nanotec's quality program) for important to safety materials and components. The manufacturing of Metamic-HT is subject to all quality assurance requirements under Holtec International's NRC approved quality program.

The tests conducted on Metamic-HT to establish the compliance of the manufactured panels with Holtec's Purchasing Specification are intended to ensure that *critical characteristics* of the final product will meet the minimum guaranteed values (MGVs) in Appendix A to Supplement 1.III of this FSAR. The tests are performed at both the raw material and manufactured panels stages of production with the former serving as the insurer of the properties in the final product and the latter serving the confirmatory function. Table 9.III.1 provides a summary of the required tests,

their frequency and their intended purpose. The terms “batch” and “lot” referred to in Table 9.III.1 have the following meanings in the context of the manufacturing of Metamic-HT.

- Lot: A lot of B₄C or of aluminum powder is the bulk of material provided by the raw material supplier with a specific property characterization data sheet. A Lot of B₄C or aluminum powder is typically in excess of 5,000 lbs.
- Batch: A batch of B₄C/Al mix is made from a distinct Lot of B₄C and a distinct lot of aluminum powder. Thus, a batch of mix cannot have B₄C (or Al) from more than one lot. All batches of mix derived from the same lot of B₄C and the same lot of aluminum are considered “sister” batches.
- A lot of Metamic-HT: A lot of Metamic-HT panels is the aggregate of all sister batches.

Note

The text in 9.III.2.2, printed in bold below, is incorporated into the HI-STORM 100 CoC by reference (CoC Appendix B, Section 3.2.9) and may not be deleted or altered in any way without prior NRC-approval via CoC amendment. The affected verbiage is, therefore, shown in bold type to distinguish it from other text.

9.III.2.2 Neutron Absorber Manufacturing and Tests

Each plate of neutron absorber shall be visually inspected for damage such as scratches, cracks, burrs, peeled cladding, foreign material embedded in the surfaces, voids, delamination, and surface finish, as applicable.

NUREG/CR-5661 identifies the main reason for a penalty in the neutron absorber B-10 density as the potential of neutron streaming due to non-uniformities in the neutron absorber, and recommends comprehensive acceptance tests to verify the presence and uniformity of the neutron absorber for credits more than 75%. Since a 90% credit is taken for Metamic-HT, the following criteria must be satisfied:

- The boron carbide powder used in the manufacturing of Metamic-HT must have sufficient fine particle size distribution to preclude neutron streaming.
- The B₄C content shall be 10 wt% (minimum).
- The B₄C powder must be uniformly dispersed locally, i.e., must not show any particle agglomeration. This precludes neutron streaming.
- The B₄C powder must be uniformly dispersed macroscopically, i.e., must have a consistent concentration throughout the entire neutron absorber panel.

To ensure that the above requirements are met the following tests shall be performed (see Table 9.III.1):

HOLTEC INTERNATIONAL COPYRIGHTED MATERIAL

- All lots of boron carbide powder shall be analyzed to meet particle size distribution requirements.
- All lots of B₄C will be certified as containing Boron with a minimum 18.3% of isotopic B-10 per the purchase specification.
- Wet chemistry testing of a sample from each mixed batch shall be performed to verify the correct boron carbide content of 10 wt% is attained. The mixing of the batch is controlled via approved procedures.
- The thickness of each final panel will be measured in at least six places, with two at one end, two at the other end and two in the middle, and shown to meet the minimum basket wall thickness.

The measurements of B₄C content, particle size, thickness, and uniformity of B₄C distribution (via wet chemistry test) shall be made using written and approved procedures. If any one of the above criterion is not met, the panel will not be used. If the wet chemistry results for a mixed batch do not meet the criteria, all panels from the entire mixed batch will not be used. This ensures the required B₄C content of the Metamic-HT panels is achieved.

As additional verification, one coupon from each lot of Metamic-HT (panels) shall be tested via neutron attenuation testing to verify the expected B₄C content is attained. The neutron attenuation testing will be performed using a 1 inch diameter thermal neutron beam that is calibrated using a solid B₄C plate, and the results will be compared to a known standard whose B₄C content has been checked and verified. This test shall be performed to verify the continued acceptability of the manufacturing process. The B₄C content attained by the neutron attenuation tests will be compared to the wet chemistry results. If a coupon fails the neutron attenuation test, all panels from this lot will be rejected.

Each plate of neutron absorber shall be visually inspected for damage such as scratches, cracks, burrs, peeled cladding, foreign material embedded in the surfaces, voids, and delaminations. Panels are also visually inspected for contamination on the surface. Panels not meeting the acceptance criteria will be rejected. Panels are inspected before being shipped to the cask manufacturing facility and they are subject to an additional receipt inspection prior to installation.

9.III.3 MAINTENANCE PROGRAM

9.III.3.1 Structural and Pressure Parts

Structural and pressure parts for the HI-STORM 100 System are discussed in the main body of this chapter.

9.III.3.2 Leakage Tests

Leakage tests for the HI-STORM 100 System are discussed in the main body of this chapter.

9.III.3.3 Subsystem Maintenance

Subsystem maintenance for the HI-STORM 100 System is discussed in the main body of this chapter.

9.III.3.4 Pressure Relief Valves

Pressure relief valves for the HI-STORM 100 System are discussed in the main body of this chapter.

9.III.3.5 Shielding

The Metamic-HT is not expected to degrade under normal long-term storage conditions. Therefore, no periodic verification testing of neutron poison material is required on the MPC-68M fuel basket.

9.III.3.6 Thermal

Thermal for the HI-STORM 100 System is discussed in the main body of this chapter.

9.III.3.7 Fuel Basket

No additional tests are required for the MPC-68M fuel basket. Long-term fuel basket integrity is ensured by fuel basket design and by extensive material testing (including the effects of creep and irradiation). The minimum guaranteed values (MGVs) provided in Table 1.III.A.1, the testing requirements in Table 9.III.1 and 9.III.2 along with the certification requirements in Table 9.III.3 ensure that the fuel basket will meet its long-term performance requirements.

9.III.4 REFERENCES

- [9.III.1] "Sampling Procedures and Tables for Inspection by Attributes", Military Standard MIL-STD-105E, (10/5/1989).

Table 9.III.1
Metamic-HT Testing Requirements

Item Tested	Property Tested For	Frequency of Test	Purpose of Test	Acceptance Criterion
B ₄ C powder (raw material) (see note 1)	Particle size distribution	One sample per lot	To verify material supplier's data sheet	Per Holtec's Purchase Specification
	Purity	One sample per lot	To verify material supplier's data sheet	ASTM C-750
Al powder (raw material)	Particle Size Distribution	One sample per lot	To verify material supplier's data sheet	Per Holtec's Purchase Specification
	Purity	One sample per lot	To verify material supplier's data sheet	Must be 99% (min.) pure aluminum
B ₄ C/Al Mix	B ₄ C Content (by the wet chemistry method)	One sample per batch	To ensure B ₄ C content requirements compliance	The B ₄ C content in accordance with the drawing package in Section 1.5
Finished Metamic-HT panel	Thickness and width, straightness, camber and bow	Each Panel	To ensure fabricability of the basket	Per Holtec's Purchasing Specification
	Properties listed in Table 9.III.3	Per Sampling Plan (see note 2)	To ensure structural performance.	MGV per Table 9.III. 3
	B ₄ C content (by neutron attenuation testing)	One coupon from each Metamic-HT manufactured lot	To ensure criticality safety	The B ₄ C content in accordance with licensing drawing in Section 1.5

Notes:

1. The B₄C testing requirements apply if the raw material supplier is not in Holtec's Approved Vendor List.
2. Sampling Plan (HTSOP-108) is included in the Metamic-HT Manufacturing Manual [1.III.A.4].

Table 9.III.2
Tier System for Coupon Testing

Tier No.	Number† of Extrusions Tested as a Percent of Number of Extrusions in the Lot	Number of Continuous Lots that Must Pass to Drop Down to the Next Tier
1	20	5
2	12.5	5
3	5	10
4	1	N/A
† Note: Three coupons from each extrusion are needed to measure the property data in Table 9.III.3.		

Table 9.III.3 Minimum Guaranteed Values Required for Certification of Production Runs of Metamic-HT (All testing performed at ambient temperature.)		
	Property	MGV
1	Yield Strength, ksi	Table 1.III.A.1 for MGV values at ambient temperature
2	Tensile Strength, ksi	
3	Young's Modulus, ksi	
4	Elongation, %	
5	Charpy Impact Strength, ft-lb	
6	Lateral Expansion, mils	
7	Area Reduction, %	

CHAPTER 10: RADIATION PROTECTION[†]

This chapter discusses the design considerations and operational features that are incorporated in the HI-STORM 100 Storage System design to protect plant personnel and the public from exposure to radioactive contamination and ionizing radiation during canister loading, closure, transfer, and on-site dry storage. Occupational exposure estimates for typical canister loading, closure, transfer operations, and ISFSI inspections are provided. An off-site dose assessment for a typical ISFSI is also discussed. Since the determination of off-site doses is necessarily site-specific, similar dose assessments are to be prepared by the licensee, as part of implementing the HI-STORM 100 Storage System in accordance with 10CFR72.212 [10.0.1]. The information provided in this chapter meets all requirements of NUREG-1536.

10.1 ENSURING THAT OCCUPATIONAL RADIATION EXPOSURES ARE AS-LOW-AS-REASONABLY-ACHIEVABLE (ALARA)

10.1.1 Policy Considerations

The HI-STORM 100 has been designed in accordance with 10CFR72 [10.0.1] and maintains radiation exposures ALARA consistent with 10CFR20 [10.1.1] and the guidance provided in Regulatory Guides 8.8 [10.1.2] and 8.10 [10.1.3]. Licensees using the HI-STORM 100 System will utilize and apply their existing site ALARA policies, procedures and practices for ISFSI activities to ensure that personnel exposure requirements of 10CFR20 [10.1.1] are met. Personnel performing ISFSI operations shall be trained on the operation of the HI-STORM 100 System, and be familiarized with the expected dose rates around the MPC, HI-STORM and HI-TRAC during all phases of loading, storage, and unloading operations. Chapter 12 provides dose rate limits at the HI-TRAC and HI-STORM surfaces to ensure that the HI-STORM 100 System is operated within design basis conditions and that ALARA goals will be met. Pre-job ALARA briefings should be held with workers and radiological protection personnel prior to work on or around the system. Worker dose rate monitoring, in conjunction with trained personnel and well-planned activities, will significantly reduce the overall dose received by the workers. When preparing or making changes to site-specific procedures for ISFSI activities, users shall ensure that ALARA practices are implemented and the 10CFR20 [10.1.1] standards for radiation protection are met in accordance with the site's written commitments. Users can further reduce dose rates around the HI-STORM 100 System by preferentially loading longer-cooled and lower-burnup spent fuel assemblies in the periphery fuel storage cells of the MPC, and loading assemblies with shorter cooling times and higher burnups in the inner MPC fuel storage cell locations. Users can also further reduce the dose rates around the HI-TRAC by the use of temporary shielding. In some cases, users may opt to upgrade their existing crane to take advantage of the increased shielding capabilities of the 125-Ton HI-TRAC transfer cask (versus

[†] This chapter has been prepared in the format and section organization set forth in Regulatory Guide 3.61. However, the material content of this chapter also fulfills the requirements of NUREG 1536. Pagination and numbering of sections, figures, and tables are consistent with the convention set down in Chapter 1, Section 1.0, herein. Finally, all terms-of-art used in this chapter are consistent with the terminology of the glossary (Table 1.0.1) and component nomenclature of the Bill-of-Materials (Section 1.5).

the 100-Ton HI-TRAC transfer cask). This decision should be based on a cost-benefit analysis. Temporary shielding and use of special tools to reduce dose is discussed in Section 10.1.4.

10.1.2 Design Considerations

Consistent with the design criteria defined in Section 2.3.5, the radiological protection criteria that limit exposure to radioactive effluents and direct radiation from an ISFSI using the HI-STORM 100 Storage System are as follows:

1. 10CFR72.104 [10.0.1] requires that for normal operation and anticipated occurrences, the annual dose equivalent to any real individual located beyond the owner-controlled area boundary must not exceed 25 mrem to the whole body, 75 mrem to the thyroid, and 25 mrem to any other critical organ. This dose would be a result of planned discharges, direct radiation from the ISFSI, and any other radiation from uranium fuel cycle operations in the area. The licensee is responsible for demonstrating site-specific compliance with these requirements.
2. 10CFR72.106 [10.0.1] requires that any individual located on or beyond the nearest owner-controlled area boundary may not receive from any design basis accident the more limiting of a total effective dose equivalent of 5 rem, or the sum of the deep dose equivalent and the committed dose equivalent to any individual organ or tissue (other than the lens of the eye) of 50 rem. The lens dose equivalent shall not exceed 15 rem and the shallow dose equivalent to skin or to any extremity shall not exceed 50 rem. The licensee is responsible for demonstrating site-specific compliance with this requirement.
3. 10CFR20 [10.1.1], Subparts C and D, limit occupational exposure and exposure to individual members of the public. The licensee is responsible for demonstrating site-specific compliance with this requirement.
4. Regulatory Position 2 of Regulatory Guide 8.8 [10.1.2] provides guidance regarding facility and equipment design features. This guidance has been followed in the design of the HI-STORM 100 Storage System as described below:
 - Regulatory Position 2a, regarding access control, is met by locating the ISFSI in a Protected Area in accordance with 10CFR72.212(b)(5)(ii) [10.0.1]. Depending on the site-specific ISFSI design, other equivalent measures may be used. Unauthorized access is prevented once a loaded HI-STORM 100 Storage cask is placed in an ISFSI. Due to the nature of the system, only limited monitoring is required, thus reducing occupational exposure and supporting ALARA considerations. The licensee is responsible for site-specific compliance with these criteria.
 - Regulatory Position 2b, regarding radiation shielding, is met by the storage cask and transfer cask biological shielding that minimizes personnel exposure, as described in Chapter 5 or later in this chapter. Fundamental design considerations that most directly influence occupational exposures with dry storage systems in general and which have been incorporated into the HI-STORM 100 System design include:

HOLTEC INTERNATIONAL COPYRIGHTED MATERIAL

- system designs that reduce or minimize the number of handling and transfer operations for each spent fuel assembly;
- system designs that reduce or minimize the number of handling and transfer operations for each MPC loading;
- system designs that maximize fuel capacity, thereby taking advantage of the self-shielding characteristics of the fuel and the reduction in the number of MPCs that must be loaded and handled;
- system designs that minimize planned maintenance requirements;
- system designs that minimize decontamination requirements at ISFSI decommissioning;
- system designs that optimize the placement of shielding with respect to anticipated worker locations and fuel placement;
- thick walled overpack that provides gamma and neutron shielding;
- thick MPC lid which provides effective shielding for operators during MPC loading and unloading operations;
- multiple welded barriers to confine radionuclides;
- smooth surfaces to reduce decontamination time;
- minimization of potential crud traps on the handling equipment to reduce decontamination requirements;
- capability of maintaining water in the MPC during welding to reduce dose rates;
- capability of maintaining water in the transfer cask annulus space and water jacket to reduce dose rates during closure operations;
- MPC penetrations located and configured to reduce streaming paths;
- HI-STORM and HI-TRAC designed to reduce streaming paths;
- MPC vent and drain ports with resealable caps to prevent the release of radionuclides during loading and unloading operations and facilitate draining, drying, and backfill operations;
- use of a pool lid, annulus seal, and Annulus Overpressure System to prevent contamination of the MPC shell outer surfaces during in-pool activities;
- temporary and auxiliary shielding to reduce dose rates around the HI-TRAC; and
- low-maintenance design to reduce doses during storage operation.

HOLTEC INTERNATIONAL COPYRIGHTED MATERIAL

- Regulatory Position 2c, regarding process instrumentation and controls, is met since there are no radioactive systems at an ISFSI.
- Regulatory Position 2d, regarding control of airborne contaminants, is met since the HI-STORM 100 Storage System is designed to withstand all design basis conditions without loss of confinement function, as described in Chapter 7 of this FSAR, and no gaseous releases are anticipated. No significant surface contamination is expected since the exterior of the MPC is kept clean by using clean water in the HI-TRAC transfer cask-MPC annulus and by using an inflatable annulus seal.
- Regulatory Position 2e, regarding crud control, is not applicable to a HI-STORM 100 Storage System ISFSI since there are no radioactive systems at an ISFSI that could transport crud.
- Regulatory Position 2f, regarding decontamination, is met since the exterior of the loaded transfer cask is decontaminated prior to being removed from the plant's fuel building. The exterior surface of the HI-TRAC transfer cask is designed for ease of decontamination. In addition, an inflatable annulus seal is used to prevent fuel pool water from contacting and contaminating the exterior surface of the MPC.
- Regulatory Position 2g, regarding monitoring of airborne radioactivity, is met since the MPC provides confinement for all design basis conditions. There is no need for monitoring since no airborne radioactivity is anticipated to be released from the casks at an ISFSI.
- Regulatory Position 2h, regarding resin treatment systems, is not applicable to an ISFSI since there are no treatment systems containing radioactive resins.
- Regulatory Position 2i, regarding other miscellaneous ALARA items, is met since stainless steel is used in the MPC shell, the primary confinement boundary. This material is resistant to the damaging effects of radiation and is well proven in the SNF cask service. Use of this material quantitatively reduces or eliminates the need to perform maintenance (or replacement) on the primary confinement system.

10.1.3 Operational Considerations

Operational considerations that most directly influence occupational exposures with dry storage systems in general and that have been incorporated into the design of the HI-STORM 100 System include:

- totally-passive design requiring minimal maintenance and monitoring (other than security monitoring) during storage;

- remotely operated welding system, lift yoke, transfer slide or mating device and moisture removal systems to reduce time operators spend in the vicinity of the loaded MPC;
- maintaining water in the MPC and the annulus region during MPC closure activities to reduce dose rates;
- low fuel assembly lift-over height of the HI-TRAC maximizes water coverage over assemblies during fuel assembly loading;
- a water-filled neutron shield jacket allows filling after removal of the HI-TRAC from the spent fuel pool. This maximizes the shielding on the HI-TRAC without exceeding the crane capacity;
- descriptive operating procedures that provide guidance to reduce equipment contamination, obtain survey information, minimize dose and alert workers to possible changing radiological conditions;
- preparation and inspection of the HI-STORM and HI-TRAC in low-dose areas;
- MPC lid fit tests and inspections prior to actual loading to ensure smooth operation during loading;
- gas sampling of the MPC and HI-STAR 100 annulus (receiving from transport) to assess the condition of the cladding and MPC confinement boundary;
- HI-STORM vent temperature elements (See Chapter 12) allow remote monitoring of the vent operability surveillance;
- wetting of component surfaces prior to placement in the spent fuel pool to reduce the need for decontamination;
- decontamination practices which consider the effects of weeping during HI-TRAC transfer cask heat up and surveying of HI-TRAC prior to removal from the fuel handling building;
- a sequence of operations based on ALARA considerations; and
- use of mock-ups and dry run training to prepare personnel for actual work situations.

10.1.4 Auxiliary/Temporary Shielding

To minimize occupational dose during loading and unloading operations, a specially-designed set of auxiliary shielding is available. The HI-STORM 100 auxiliary shielding consists of the Automated Welding System Baseplate, the HI-TRAC Temporary Shield Ring, the annulus shield, HI-STORM vent shield insert, the HI-TRAC transfer step or mating device, and the shield panel trim plates. Additional supplemental shielding such as lead blankets and bricks or other such shielding may also be used to help reduce dose rates. Each auxiliary shield is described in Table 10.1.1, shown on Figure 10.1.1 and the procedures for utilization are provided in Chapter 8. Other embodiments of the temporary shielding may also be used. Table 10.1.2

provides the minimum requirements for use of the temporary shielding indicating optional and required shielding. Users shall evaluate the need for auxiliary and temporary shielding and use of special tooling to reduce the overall exposure based on an ALARA review of cask loading operations and the MPC contents.

HOLTEC INTERNATIONAL COPYRIGHTED MATERIAL

HI-STORM FSAR
REPORT HI-2002444

10.1-6

Rev. 5

HI-STORM 100 FSAR, NON-PROPRIETARY
REVISION 12
MARCH 12, 2014

Table 10.1.1
HI-STORM 100 AUXILIARY AND TEMPORARY SHIELDS

Temporary Shield	Description	Utilization
Automated Welding System Baseplate	Thick gamma and neutron shield circular plate that sits on the MPC lid. Plate is set directly on the MPC. Threaded lift holes are provided to assist in rigging.	Used during MPC closure and unloading operations in the cask preparation area to reduce the dose rates around the MPC lid. The design of the closure ring allows the baseplate shield to remain in place during the entire closure operation.
HI-TRAC Temporary Shield Ring	A water-filled tank that is placed atop of the HI-STAR or HI-TRAC neutron shield.	Used during MPC and HI-TRAC closure operations and MPC transfers into HI-STAR to reduce dose rates to the operators around the top flange of the HI-TRAC.
Annulus Shield	A shield that is seated between the MPC shell and the HI-TRAC.	Used during MPC closure operations to reduce streaming from the annulus.
HI-TRAC Transfer Step	A stepped block used to position the pool lid and transfer lid at the same elevation. The transfer step creates a tight seam between the two lids to eliminate streaming during bottom lid replacement.	Used during HI-TRAC 100 or 125 bottom lid replacement.
HI-TRAC Mating Device	Device used to remove HI-TRAC pool lid and to provide shielding during MPC transfer to HI-STORM..	Used during MPC transfer to the HI-STORM when used with HI-TRAC 100D or 125D
Shield Panel Trim Plates	Four steel plates approximately 0.25 inch by 3 inch by 80 inch that are placed at the ends of the transfer lid top and bottom plate and secured by clamps or other method deemed suitable by the user.	Used during MPC transfer to and from HI-TRAC to shield the small gap above and below the sliding doors on the transfer lid.
HI-STORM Vent Shield Inserts	Devices shaped to fit into the HI-STORM exit vents.	Used during MPC transfer to and from HI-STORM to eliminate the streaming path from the exit vents during MPC transfer operations.

HOLTEC INTERNATIONAL COPYRIGHTED MATERIAL

Table 10.1.2
 HI-STORM 100 AUXILIARY AND TEMPORARY SHIELD REQUIREMENTS

Auxiliary Shielding	Required for the 100-Ton HI-TRAC and HI-TRAC 100D	Required for the 125-ton HI-TRAC and HI-TRAC 125D
Temporary Shield Ring	Note 1	Note 1
Automated Welding System Baseplate Shield	No	No
Annulus Shield	Note 1	Note 1
Vent Duct Shield Inserts	Note 2	Note 2
Transfer Step	Yes (Note 3)	Yes (Note 3)
Trim Plates	No	No
Mating Device	Yes (Note 4)	Yes (Note 4)

Notes:

1. Users shall determine the need for this temporary shielding based on the specific operations and the MPC contents.
2. Not required for the HI-STORM 100S Overpack.
3. Not used with the HI-TRAC 100D or 125D.
4. Used only with HI-TRAC 100D or 125D

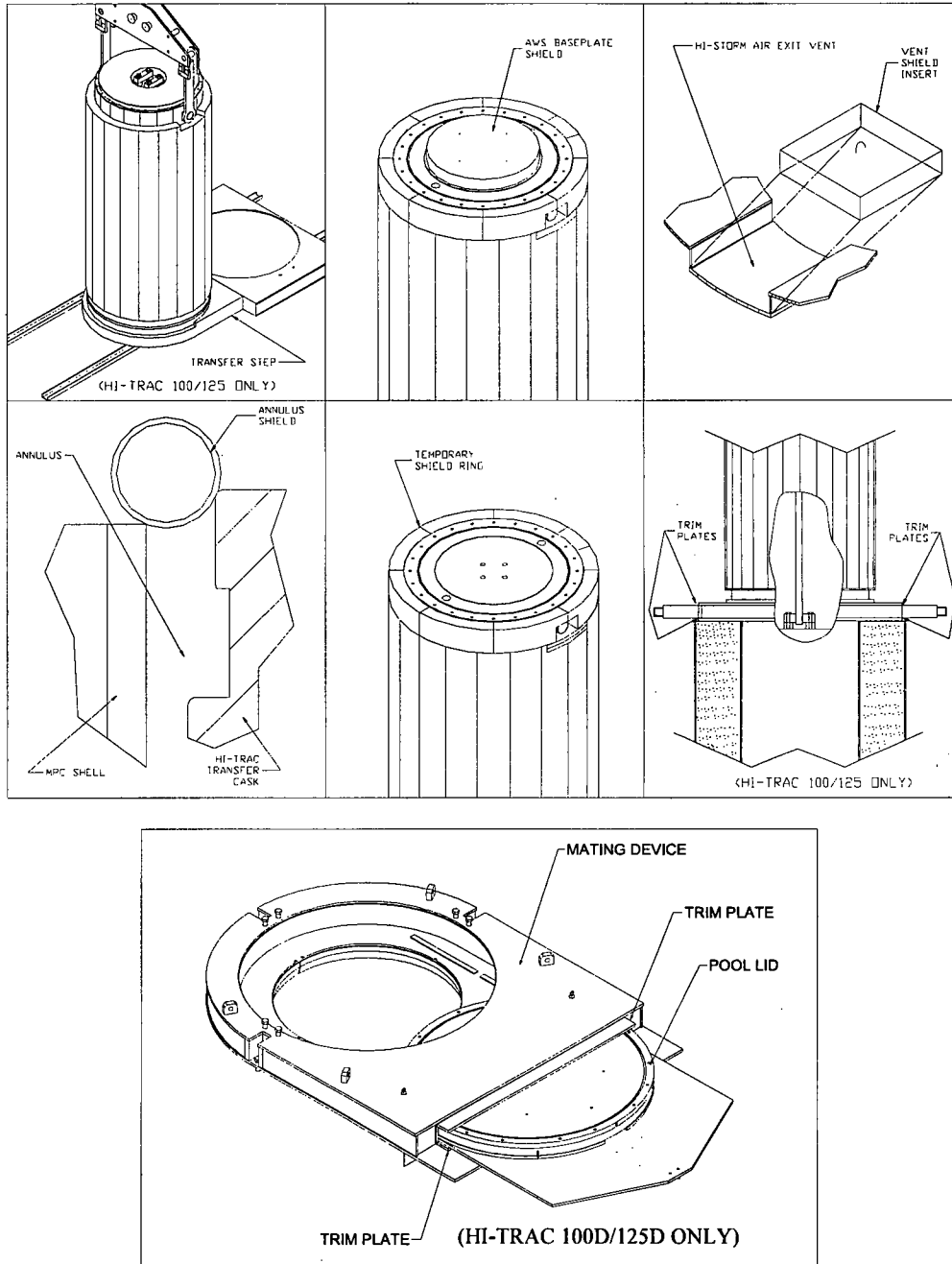


Figure 10.1.1; HI-STORM 100 System Auxiliary/Temporary Shielding

HOLTEC INTERNATIONAL COPYRIGHTED MATERIAL

HI-STORM FSAR
REPORT HI-2002444

Rev. 4

HI-STORM 100 FSAR, NON-PROPRIETARY
REVISION 12
MARCH 12, 2014

10.2 RADIATION PROTECTION DESIGN FEATURES

The development of the HI-STORM 100 System has focused on design provisions to address the considerations summarized in Sections 10.1.2 and 10.1.3. The intent has been to improve on past concrete-based dry storage system designs by developing HI-STORM 100 as a hybrid of current metal and concrete storage system technologies. The design is, therefore, an evolution in storage systems, which incorporates preferred features from concrete storage, canister-based systems while retaining several of the advantages of metal casks as well. This approach results in a reduction in the need for maintenance, in overall radiation levels, and in the time spent on maintenance, when compared with current concrete-based dry storage systems. The following specific design features ensure a high degree of confinement integrity and radiation protection:

- HI-STORM 100 has been designed to meet storage condition dose rates required by 10CFR72 [10.0.1] for three-year cooled fuel;
- HI-STORM 100 has been designed to accommodate a maximum number of PWR or BWR fuel assemblies to minimize the number of cask systems that must be handled and stored at the storage facility and later transported off-site;
- HI-STORM 100 overpack structure is virtually maintenance free, especially over the years following its initial loading, because of the outer metal shell. The metal shell and its protective coating provide a high level of resistance to corrosion and other forms of degradation (e.g., erosion);
- HI-STORM 100 has been designed for redundant, multi-pass welded closures on the MPC; consequently, no monitoring of the confinement boundary is necessary and no gaseous or particulate releases occur for normal, off-normal or credible accident conditions;
- HI-TRAC transfer cask utilizes a mating device or transfer step and other auxiliary shielding devices which reduce streaming paths and simplify operations;
- The pool lid maximizes available fuel assembly water coverage in the spent fuel pool.
- The transfer lid and mating device are designed for quick alignment with HI-STORM; and
- HI-STORM 100 has been designed to allow close positioning (pitch) on the ISFSI storage pad, thereby increasing the ISFSI self-shielding by decreasing the view factors and reducing exposures to on-site and off-site personnel.

HOLTEC INTERNATIONAL COPYRIGHTED MATERIAL

HI-STORM FSAR
REPORT HI-2002444

10.2-1

Rev. 3

10.3 ESTIMATED ON-SITE COLLECTIVE DOSE ASSESSMENT

This section provides the estimates of the cumulative exposure to personnel performing loading, unloading and transfer operations using the HI-STORM system. This section uses the shielding analysis provided in Chapter 5 and the operations procedures provided in Chapter 8 to develop a dose assessment. The dose assessment is provided in Tables 10.3.1, 10.3.2, and 10.3.3.

The dose rates from the HI-STORM 100 overpack, MPC lid, HI-TRAC transfer cask, and HI-STAR 100 overpack are calculated to determine the dose to personnel during the various loading and unloading operations. The dose rates are also calculated for the various conditions of the cask that may affect the dose rates to the operators (e.g., MPC water level, HI-TRAC annulus water level, neutron shield water level, presence of temporary shielding). The dose rates around the 100-Ton HI-TRAC transfer cask are based on 24 PWR fuel assemblies with a burnup of 60,000 MWD/MTU and cooling of 3 years including BPRAs. The dose rates around the 125-Ton HI-TRAC transfer cask are based on 24 PWR fuel assemblies with a burnup of 75,000 MWD/MTU and cooling of 5 years including BPRAs. The dose rates around the HI-STORM 100 overpack are based on 24 PWR fuel assemblies with a burnup of 60,000 MWD/MTU and cooling of 3 years. The selection of these fuel assembly types in all fuel cell locations bound all possible PWR and BWR loading scenarios for the HI-STORM System from a dose-rate perspective. The HI-STORM dose rates used in this chapter were calculated for the HI-STORM 100 S Version B. No assessment is made with respect to background radiation since background radiation can vary significantly by site. In addition, exposures are based on work being performed with the temporary shielding described in Table 10.1.2.

The choice of burnup and cooling times used in this chapter is extremely conservative. The bounding burnup and cooling time that resulted in the highest dose rates around the 100-ton, 125-ton HI-TRACs, and HI-STORM 100S Version B were used. In addition, including the source term from BPRAs increases the level of conservatism. The maximum dose rate due to BPRAs was used in this analysis. As stated in Chapter 5, using the maximum source for the BPRAs in conjunction with the bounding burnup and cooling time for fuel assemblies is very conservative as it is not expected that burnup and cooling times of the BPRAs and fuel assemblies would be such that they are both at the maximum design basis values. This combined with the already conservative dose rates for the HI-TRACs and HI-STORMs results in an upper bound estimate of the occupational exposure. Users' radiation protection programs will assure appropriate temporary shielding is used based on actual fuel to be loaded and resulting dose rates in the field.

For each step in Tables 10.3.1 through 10.3.3, the operator work location is identified. These correspond to the locations identified in Figure 10.3.1. The relative locations refer to all HI-STORM Overpacks. The dose rate location points around the transfer cask and overpack were selected to model actual worker locations and cask conditions during the operation. Cask operators typically work at an arms-reach distance from the cask. To account for this, an 18-inch

distance was used to estimate the dose rate for the worker. This assessment addresses only the operators that perform work on or immediately adjacent to the cask.

Justification for the duration of operations along with the corresponding procedure Sections from Chapter 8 are also provided in the tables. The assumptions used in developing time durations are based on mockups of the MPC, review of design drawings, walk-downs using other equipment to represent the HI-TRAC transfer cask and HI-STORM 100 overpack the HI-STAR 100 overpack and MPC-68 prototype, consultation with UST&D (weld examination) and consultation with cask operations personnel from Calvert Cliffs Nuclear Power Plant (for items such as lid installation and decontamination). In addition, for the shielding calculations, only the Temporary Shield Ring was assumed to be in place for applicable portions of the operations.

Tables 10.3.1a, 10.3.1b, and 10.3.1c provide a summary of the dose assessment for a HI-STORM 100 System loading operation using the 125-ton HI-TRAC, the 100-ton HI-TRAC, and the HI-TRAC 125D respectively. Tables 10.3.2a, 2b, and 2c provide a summary of the dose assessment for HI-STORM 100 System unloading operations using the 125-ton HI-TRAC, the 100-ton HI-TRAC, and HI-TRAC 125D respectively. Tables 10.3.3a, 3b, and 3c provide a summary of the dose assessment for transferring the MPC to a HI-STAR 100 overpack as described in Section 8.5 of the operating procedures using the 125-ton HI-TRAC, the 100-ton HI-TRAC, and 125-ton HI-TRAC 125D, respectively. The HI-TRAC 100D was not specifically analyzed since, as stated in Section 5.4, the dose rates from the HI-TRAC 100 and 100D are similar at 1 meter from the overpack. In addition, the results for the HI-TRAC 125 and 125D indicate that there is only a small difference in the occupational exposure from using a mating device (HI-TRAC 125D) rather than transfer doors. Therefore, the use of the mating device in the HI-TRAC 100D does not result in occupational exposures significantly different than those presented for the 100-ton HI-TRAC.

10.3.1 Estimated Exposures for Loading and Unloading Operations

The assumptions used to estimate personnel exposures are conservative by design. The main factors attributed to actual personnel exposures are the age and burnup of the spent fuel assemblies and good ALARA practices. To estimate the dose received by a single worker, it should be understood that a canister-based system requires a diverse range of disciplines to perform all the necessary functions. The high visibility and often critical path nature of fuel movement activities have prompted utilities to load canister systems in a round-the-clock mode in most cases. This results in the exposure being spread out over several shifts of operators and technicians with no single shift receiving a majority of the exposure.

The total person-rem exposure from operation of the HI-STORM 100 System is proportional to the number of systems loaded. A typical utility will load approximately four MPCs per reactor cycle to maintain the current available spent fuel pool capacity. Utilities requiring dry storage of spent fuel assemblies typically have a large inventory of spent fuel assemblies that date back to the reactor's first cycle. The older fuel assemblies will have a significantly lower dose rate than the design basis fuel assemblies due to the extended cooling time (i.e., much greater than the

values used to compute the dose rates). Users shall assess the cask loading for their particular fuel types (burnup, cooling time) to satisfy the requirements of 10CFR20 [10.1.1].

For licensees using the 100-Ton HI-TRAC transfer cask, design basis dose rates will be higher (than a corresponding 125-Ton HI-TRAC) due to the decreased mass of shielding. Due to the higher expected dose rates from the 100-Ton HI-TRAC, users may need to use the auxiliary shielding (See Table 10.1.2), and should consider preferential loading, and increased precautions (e.g., additional temporary or auxiliary shielding, remotely operated equipment, additional contamination prevention measures). Actual use of optional dose reduction measures must be decided by each user based on the fuel to be loaded.

10.3.2 Estimated Exposures for Surveillance and Maintenance

Table 10.3.4 provides an estimate of the occupational exposure required for security surveillance and maintenance of an ISFSI. Security surveillance time is based on a daily security patrol around the perimeter of the ISFSI security fence. Users may opt to utilize electronic temperature monitoring of the HI-STORM modules or remote viewing methods instead of performing direct visual observation of the modules. Since security surveillances can be performed from outside the ISFSI, and since the ISFSI fence is typically positioned such that the area outside the fence is not a radiation area, a dose rate of 3 mrem/hour is estimated. Although the HI-STORM 100 System requires only minimal maintenance during storage (e.g. touch-up paint), maintenance will be required around the ISFSI for items such as security equipment maintenance, grass cutting, snow removal, vent system surveillance, drainage system maintenance, and lighting, telephone, and intercom repair. Since most of the maintenance is expected to occur outside the actual cask array, a dose rate of 10 mrem/hour is estimated.

Table 10.3.1a							
HI-STORM 100 SYSTEM LOADING OPERATIONS USING THE 125-TON HI-TRAC TRANSFER CASK							
ESTIMATED OPERATIONAL EXPOSURES[†] (75,000 MWD/MTU, 5-YEAR COOLED PWR FUEL)							
ACTION	DURATION (MINUTES)	OPERATOR LOCATION (FIGURE 10.3.1)	NUMBER OF OPERATORS	DOSE RATE AT OPERATOR LOCATION (MREM/HR)	DOSE TO INDIVIDUAL (MREM)	TOTAL DOSE (PERSON- MREM)	ASSUMPTIONS
Section 8.1.4							
LOAD PRE-SELECTED FUEL ASSEMBLIES INTO MPC	1020	1	2	1	17.0	34.0	15 MINUTES PER ASSEMBLY/68 ASSY
PERFORM POST-LOADING VISUAL VERIFICATION OF ASSEMBLY IDENTIFICATION	68	1	2	1	1.1	2.3	1 MINUTES PER ASSY/68 ASSY
Section 8.1.5							
INSTALL MPC LID AND ATTACH LIFT YOKE	45	2	2	2.0	1.5	3.0	CONSULTATION WITH CALVERT CLIFFS
RAISE HI-TRAC TO SURFACE OF SPENT FUEL POOL	20	2	2	2.0	0.7	1.3	40 FEET @ 2 FT/MINUTE (CRANE SPEED)
SURVEY MPC LID FOR HOT PARTICLES	3	3A	1	31.1	1.6	1.6	TELESCOPING DETECTOR USED
VERIFY MPC LID IS SEATED	0.5	3A	1	31.1	0.3	0.3	VISUAL VERIFICATION FROM 3 METERS
INSTALL LID RETENTION SYSTEM BOLTS	6	3B	2	46.4	4.6	9.3	24 BOLTS @ 2/PERSON-MINUTE
REMOVE HI-TRAC FROM SPENT FUEL POOL	8.5	3C	1	117.8	16.7	16.7	17 FEET @ 2 FT/MIN (CRANE SPEED)
DECONTAMINATE HI-TRAC BOTTOM	10	3D	1	142.0	23.7	23.7	LONG HANDLED TOOLS, PRELIMINARY DECON
TAKE SMEARS OF HI-TRAC EXTERIOR SURFACES	5	5B	1	185.3	15.4	15.4	50 SMEARS @ 10 SMEARS/MINUTE
DISCONNECT ANNULUS OVERPRESSURE SYSTEM	0.5	5C	1	82.7	0.7	0.7	QUICK DISCONNECT COUPLING
SET HI-TRAC IN CASK PREPARATION AREA	10	4A	1	46.4	7.7	7.7	100 FT @ 10 FT/MIN (CRANE SPEED)
REMOVE NEUTRON SHIELD JACKET FILL PLUG	2	4A	1	46.4	1.5	1.5	SINGLE PLUG, NO SPECIAL TOOLS
INSTALL NEUTRON SHIELD JACKET FILL PLUG	2	5B	1	185.3	6.2	6.2	SINGLE PLUG, NO SPECIAL TOOLS
DISCONNECT LID RETENTION SYSTEM	6	5A	2	37.3	3.7	7.5	24 BOLTS @ 2 BOLT/PERSON MINUTES
MEASURE DOSE RATES AT MPC LID	3	5A	1	37.3	1.9	1.9	TELESCOPING DETECTOR USED

[†] See notes at bottom of Table 10.3.4.

Table 10.3.1a
HI-STORM 100 SYSTEM LOADING OPERATIONS USING THE 125-TON HI-TRAC TRANSFER CASK
ESTIMATED OPERATIONAL EXPOSURES† (75,000 MWD/MTU, 5-YEAR COOLED PWR FUEL)

ACTION	DURATION (MINUTES)	OPERATOR LOCATION (FIGURE 10.3.1)	NUMBER OF OPERATORS	DOSE RATE AT OPERATOR LOCATION (MREM/HR)	DOSE TO INDIVIDUAL (MREM)	TOTAL DOSE (PERSON-MREM)	ASSUMPTIONS
DECONTAMINATE AND SURVEY HI-TRAC	103	5B	1	185.3	318.1	318.1	490 SQ-FT@5 SQ-FT/PERSON-MINUTE+50 SMEARS@10 SMEARS/MINUTE
INSTALL TEMPORARY SHIELD	16	6A	2	18.7	5.0	10.0	8 SEGMENTS @ 1 SEGMENT/PERSON MIN
FILL TEMPORARY SHIELD RING	25	6A	1	18.7	7.8	7.8	230 GAL @10GPM, LONG HANDLED SPRAY WAND
ATTACH DRAIN LINE TO HI-TRAC DRAIN PORT	0.5	5C	1	82.7	0.7	0.7	QUICK DISCONNECT COUPLING
INSTALL RVOAs	2	6A	1	18.7	0.6	0.6	SINGLE THREADED CONNECTION X 2 RVOAs
ATTACH WATER PUMP TO DRAIN PORT	2	6A	1	18.7	0.6	0.6	POSITION PUMP SELF PRIMING
DISCONNECT WATER PUMP	5	6A	1	18.7	1.6	1.6	DRAIN HOSES MOVE PUMP
DECONTAMINATE MPC LID TOP SURFACE AND SHELL AREA ABOVE INFLATABLE ANNULUS SEAL	6	6A	1	18.7	1.9	1.9	30 SQ-FT @5 SQ-FT/MINUTE+10 SMEARS@10 SMEARS/MINUTE
REMOVE INFLATABLE ANNULUS SEAL	3	6A	1	18.7	0.9	0.9	SEAL PULLS OUT DIRECTLY
SURVEY MPC LID TOP SURFACES AND ACCESSIBLE AREAS OF TOP THREE INCHES OF MPC SHELL	1	6A	1	18.7	0.3	0.3	10 SMEARS@10 SMEARS/MINUTE
INSTALL ANNULUS SHIELD	2	6A	1	18.7	0.6	0.6	SHIELD PLACED BY HAND
CENTER LID IN MPC SHELL	20	6A	3	18.7	6.2	18.7	CONSULTATION WITH CALVERT CLIFFS
INSTALL MPC LID SHIMS	12	6A	2	18.7	3.7	7.5	MEASURED DURING WELD MOCKUP TESTING
POSITION AWS BASEPLATE SHIELD ON MPC LID	20	7A	2	18.7	6.2	12.5	ALIGN AND REMOVE 4 SHACKLES
INSTALL AUTOMATED WELDING SYSTEM ROBOT	8	7A	2	18.7	2.5	5.0	ALIGN AND REMOVE 4 SHACKLES/4 QUICK CONNECTS@1/MIN
PERFORM NDE ON LID WELD	230	7A	1	18.7	71.7	71.7	MEASURED DURING WELD MOCKUP TESTING
ATTACH DRAIN LINE TO VENT PORT	1	7A	1	18.7	0.3	0.3	1" THREADED FITTING NO TOOLS
VISUALLY EXAMINE MPC LID-TO-SHELL WELD FOR LEAKAGE OF WATER	10	7A	1	18.7	3.1	3.1	10 MIN TEST DURATION
DISCONNECT WATER FILL LINE AND DRAIN LINE	2	7A	1	18.7	0.6	0.6	1" THREADED FITTING NO TOOLS X 2

HOLTEC INTERNATIONAL COPYRIGHTED MATERIAL

Table 10.3.1a
HI-STORM 100 SYSTEM LOADING OPERATIONS USING THE 125-TON HI-TRAC TRANSFER CASK
ESTIMATED OPERATIONAL EXPOSURES[†] (75,000 MWD/MTU, 5-YEAR COOLED PWR FUEL)

ACTION	DURATION (MINUTES)	OPERATOR LOCATION (FIGURE 10.3.1)	NUMBER OF OPERATORS	DOSE RATE AT OPERATOR LOCATION (MREM/HR)	DOSE TO INDIVIDUAL (MREM)	TOTAL DOSE (PERSON-MREM)	ASSUMPTIONS
REPEAT LIQUID PENETRANT EXAMINATION ON MPC LID FINAL PASS	45	7A	1	18.7	14.0	14.0	5 MIN TO APPLY, 7 MIN TO WIPE, 5 APPLY DEV, INSP (24 IN/MIN)
ATTACH GAS SUPPLY TO VENT PORT	1	7A	1	18.7	0.3	0.3	1" THREADED FITTING NO TOOLS
ATTACH DRAIN LINE TO DRAIN PORT	1	7A	1	18.7	0.3	0.3	1" THREADED FITTING NO TOOLS
Deleted							
Deleted							SIMPLE ATTACHMENT NO TOOLS
ATTACH DRAIN LINE TO VENT PORT	1	8A	1	37.9	0.6	0.6	1" THREADED FITTING NO TOOLS
ATTACH WATER FILL LINE TO DRAIN PORT	1	8A	1	37.9	0.6	0.6	1" THREADED FITTING NO TOOLS
DISCONNECT WATER FILL DRAIN LINES FROM MPC	2	8A	1	37.9	1.3	1.3	1" THREADED FITTING NO TOOLS X 2
ATTACH HELIUM SUPPLY TO VENT PORT	1	8A	1	37.9	0.6	0.6	1" THREADED FITTING NO TOOLS
ATTACH DRAIN LINE TO DRAIN PORT	1	8A	1	37.9	0.6	0.6	1" THREADED FITTING NO TOOLS
DISCONNECT GAS SUPPLY LINE FROM MPC	1	8A	1	37.9	0.6	0.6	1" THREADED FITTING NO TOOLS
DISCONNECT DRAIN LINE FROM MPC	1	8A	1	37.9	0.6	0.6	1" THREADED FITTING NO TOOLS
ATTACH MOISTURE REMOVAL SYSTEM TO VENT AND DRAIN PORT RVOAs	2	8A	1	37.9	1.3	1.3	1" THREADED FITTING NO TOOLS
DISCONNECT MOISTURE REMOVAL SYSTEM FROM MPC	2	8A	1	37.9	1.3	1.3	1" THREADED FITTING NO TOOLS X 2
CLOSE DRAIN PORT RVOA CAP AND REMOVE DRAIN PORT RVOA	1.5	8A	1	37.9	0.9	0.9	SINGLE THREADED CONNECTION (1 RVOA)
ATTACH HELIUM BACKFILL SYSTEM TO VENT PORT	1	8A	1	37.9	0.6	0.6	1" THREADED FITTING NO TOOLS
DISCONNECT HBS FROM MPC	1	8A	1	37.9	0.6	0.6	1" THREADED FITTING NO TOOLS
CLOSE VENT PORT RVOA AND DISCONNECT VENT PORT RVOA	1.5	8A	1	37.9	0.9	0.9	SINGLE THREADED CONNECTION (1 RVOA)
WIPE INSIDE AREA OF VENT AND DRAIN PORT RECESSES	2	8A	1	37.9	1.3	1.3	2 PORTS, 1 MIN/PORT
PLACE COVER PLATE OVER VENT PORT RECESS	1	8A	1	37.9	0.6	0.6	INSTALLED BY HAND NO TOOLS (2/MIN)
PERFORM NDE ON VENT AND DRAIN COVER PLATE WELD	100	8A	1	37.9	63.2	63.2	MEASURED DURING WELD MOCKUP TESTING

HOLTEC INTERNATIONAL COPYRIGHTED MATERIAL

Table 10.3.1a
HI-STORM 100 SYSTEM LOADING OPERATIONS USING THE 125-TON HI-TRAC TRANSFER CASK
ESTIMATED OPERATIONAL EXPOSURES[†] (75,000 MWD/MTU, 5-YEAR COOLED PWR FUEL)

ACTION	DURATION (MINUTES)	OPERATOR LOCATION (FIGURE 10.3.1)	NUMBER OF OPERATORS	DOSE RATE AT OPERATOR LOCATION (MREM/HR)	DOSE TO INDIVIDUAL (MREM)	TOTAL DOSE (PERSON-MREM)	ASSUMPTIONS
FLUSH CAVITY WITH HELIUM AND INSTALL SET SCREWS	2	8A	1	37.9	1.3	1.3	4 SET SCREWS @2/MINUTE
PLUG WELD OVER SET SCREWS	8	8A	1	37.9	5.1	5.1	FOUR SINGLE SPOT WELDS @ 1 PER 2 MINUTES
INSTALL MSLD OVER VENT PORT COVER PLATE	2	8A	1	37.9	1.3	1.3	INSTALLED BY HAND, NO TOOLS
INSTALL MSLD OVER DRAIN PORT COVER PLATE	2	8A	1	37.9	1.3	1.3	INSTALLED BY HAND, NO TOOLS
INSTALL AND ALIGN CLOSURE RING	5	8A	1	37.9	3.2	3.2	INSTALLED BY HAND NO TOOLS
PERFORM NDE ON CLOSURE RING WELDS	185	8A	1	37.9	116.9	116.9	MEASURED DURING WELD MOCKUP TESTING
RIG AWS TO CRANE	12	8A	1	37.9	7.6	7.6	10 MIN TO DISCONNECT LINES, 4 SHACKLES@2/MIN
Section 8.1.6							
REMOVE ANNULUS SHIELD	1	8A	1	37.9	0.6	0.6	SHIELD PLACED BY HAND
ATTACH DRAIN LINE TO HI-TRAC	1	9D	1	354.2	5.9	5.9	1" THREADED FITTING NO TOOLS
POSITION HI-TRAC TOP LID	10	9B	2	37.9	6.3	12.6	VERTICAL FLANGED CONNECTION
TORQUE TOP LID BOLTS	12	9B	1	37.9	7.6	7.6	24 BOLTS AT 2/MIN (INSTALL AND TORQUE, 1 PASS)
INSTALL MPC LIFT CLEATS AND MPC SLINGS	25	9A	2	158.5	66.0	132.1	INSTALL CLEATS AND HYDRO TORQUE 4 BOLTS
REMOVE TEMPORARY SHIELD RING DRAIN PLUGS	1	9B	1	37.9	0.6	0.6	8 PLUGS @ 8/MIN
REMOVE TEMPORARY SHIELD RING SEGMENTS	4	9A	1	158.5	10.6	10.6	REMOVED BY HAND NO TOOLS (8 SEGS@2/MIN)
ATTACH MPC SLINGS TO LIFT YOKE	4	9A	2	158.5	10.6	21.1	INSTALLED BY HAND NO TOOLS
POSITION HI-TRAC ABOVE TRANSFER STEP	15	9C	1	117.8	29.5	29.5	100 FT @ 10 FT/MIN (CRANE SPEED)+ 5MIN TO ALIGN
REMOVE BOTTOM LID BOLTS	6	10A	1	354.2	35.4	35.4	36 BOLTS@6 BOLTS/MIN IMPACT TOOLS USED
INSTALL TRANSFER LID BOLTS	18	11B	1	354.2	106.3	106.3	36 BOLTS @ 2/MIN IMPACT TOOLS USED 1 PASS
DISCONNECT MPC SLINGS	4	9A	2	158.5	10.6	21.1	INSTALLED BY HAND NO TOOLS
Section 8.1.7							
POSITION HI-TRAC ON TRANSPORT DEVICE	20	11A	2	117.8	39.3	78.5	ALIGN TRUNNIONS, DISCONNECT LIFT YOKE
TRANSPORT HI-TRAC TO OUTSIDE TRANSFER LOCATION	90	12A	3	26.4	39.6	118.8	DRIVER AND 2 SPOTTERS

HOLTEC INTERNATIONAL COPYRIGHTED MATERIAL

Table 10.3.1a
HI-STORM 100 SYSTEM LOADING OPERATIONS USING THE 125-TON HI-TRAC TRANSFER CASK
ESTIMATED OPERATIONAL EXPOSURES[†] (75,000 MWD/MTU, 5-YEAR COOLED PWR FUEL)

ACTION	DURATION (MINUTES)	OPERATOR LOCATION (FIGURE 10.3.1)	NUMBER OF OPERATORS	DOSE RATE AT OPERATOR LOCATION (MREM/HR)	DOSE TO INDIVIDUAL (MREM)	TOTAL DOSE (PERSON-MREM)	ASSUMPTIONS
ATTACH OUTSIDE LIFTING DEVICE LIFT LINKS	2	12A	2	26.4	0.9	1.8	2 LINKS@1/MIN
MATE OVERPACKS	10	13B	2	118.5	19.8	39.5	ALIGNMENT GUIDES USED
ATTACH MPC SLINGS TO MPC LIFT CLEATS	10	13A	2	158.5	26.4	52.8	2 SLINGS@5MIN/SLING NO TOOLS
REMOVE TRANSFER LID DOOR LOCKING PINS AND OPEN DOORS	4	13B	2	118.5	7.9	15.8	2 PINS@2MIN/PIN
INSTALL TRIM PLATES	4	13B	2	118.5	7.9	15.8	INSTALLED BY HAND
DISCONNECT SLINGS FROM MPC LIFTING DEVICE	10	13A	2	158.5	26.4	52.8	2 SLINGS@5MIN/SLING
REMOVE MPC LIFT CLEATS AND MPC SLINGS	10	14A	1	487.4	81.2	81.2	4 BOLTS,NO TORQUING
INSTALL HOLE PLUGS IN EMPTY MPC BOLT HOLES	2	14A	1	487.4	16.2	16.2	4 PLUGS AT 2/MIN NO TORQUING
REMOVE HI-STORM VENT DUCT SHIELD INSERTS	2	15A	1	43.9	1.5	1.5	4 SHACKLES@2/MIN
REMOVE ALIGNMENT DEVICE	4	15A	1	43.9	2.9	2.9	REMOVED BY HAND NO TOOLS (4 PCS@1/MIN)
INSTALL HI-STORM LID AND INSTALL LID STUDS/NUTS	25	16A	2	11.7	4.9	9.8	INSTALL LID AND HYDRO TORQUE 4 BOLTS
INSTALL HI-STORM EXIT VENT GAMMA SHIELD CROSS PLATES	4	16B	1	205.5	13.7	13.7	4 PCS @ 1/MIN INSTALL BY HAND NO TOOLS
INSTALL TEMPERATURE ELEMENTS	20	16B	1	205.5	68.5	68.5	4@5MIN/TEMPERATURE ELEMENT
INSTALL EXIT VENT SCREENS	20	16B	1	205.5	68.5	68.5	4 SCREENS@5MIN/SCREEN
REMOVE HI-STORM LID LIFTING DEVICE	2	16A	1	11.7	0.4	0.4	4 SHACKLES@2/MIN
INSTALL HOLE PLUGS IN EMPTY HOLES	2	16A	1	11.7	0.4	0.4	4 PLUGS AT 2/MIN NO TORQUING
PERFORM SHIELDING EFFECTIVENESS TESTING	16	16D	2	122.7	32.7	65.4	16 POINTS@1 MIN
SECURE HI-STORM TO TRANSPORT DEVICE	10	16A	2	11.7	2.0	3.9	ASSUMES AIR PAD
TRANSFER HI-STORM TO ITS DESIGNATED STORAGE LOCATION	40	16C	1	69.7	46.5	46.5	200 FEET @ 4FT/MIN
INSERT HI-STORM LIFTING JACKS	4	16D	1	122.7	8.2	8.2	4 JACKS@1/MIN
REMOVE AIR PAD	5	16D	2	122.7	10.2	20.5	1 PAD MOVED BY HAND
REMOVE HI-STORM LIFTING JACKS	4	16D	1	122.7	8.2	8.2	4 JACKS@1/MIN
INSTALL INLET VENT SCREENS/CROSS PLATES	20	16D	1	122.7	40.9	40.9	4 SCREENS@5MIN/SCREEN

HOLTEC INTERNATIONAL COPYRIGHTED MATERIAL

Table 10.3.1a
HI-STORM 100 SYSTEM LOADING OPERATIONS USING THE 125-TON HI-TRAC TRANSFER CASK
ESTIMATED OPERATIONAL EXPOSURES[†] (75,000 MWD/MTU, 5-YEAR COOLED PWR FUEL)

ACTION	DURATION (MINUTES)	OPERATOR LOCATION (FIGURE 10.3.1)	NUMBER OF OPERATORS	DOSE RATE AT OPERATOR LOCATION (MREM/HR)	DOSE TO INDIVIDUAL (MREM)	TOTAL DOSE (PERSON- MREM)	ASSUMPTIONS
PERFORM AIR TEMPERATURE RISE TEST	8	16B	1	205.5	27.4	27.4	8 MEASUREMENTS@1/MIN
TOTAL							2063.1 PERSON-MREM

Table 10.3.1b
HI-STORM 100 SYSTEM LOADING OPERATIONS USING THE 100-TON HI-TRAC TRANSFER CASK
ESTIMATED OPERATIONAL EXPOSURES[†] (60,000 MWD/MTU, 3-YEAR COOLED PWR FUEL)

ACTION	DURATION (MINUTES)	OPERATOR LOCATION (FIGURE 10.3.1)	NUMBER OF OPERATORS	DOSE RATE AT OPERATOR LOCATION (MREM/HR)	DOSE TO INDIVIDUAL (MREM)	TOTAL DOSE (PERSON-MREM)	ASSUMPTIONS
Section 8.1.4							
LOAD PRE-SELECTED FUEL ASSEMBLIES INTO MPC	1020	1	2	3	51.0	102.0	15 MINUTES PER ASSEMBLY/68 ASSY
PERFORM POST-LOADING VISUAL VERIFICATION OF ASSEMBLY IDENTIFICATION	68	1	2	3	3.4	6.8	1 MINUTES PER ASSY/68 ASSY
Section 8.1.5							
INSTALL MPC LID AND ATTACH LIFT YOKE	45	2	2	3	2.3	4.5	CONSULTATION WITH CALVERT CLIFFS
RAISE HI-TRAC TO SURFACE OF SPENT FUEL POOL	20	2	2	3	1.0	2.0	40 FEET @ 2 FT/MINUTE (CRANE SPEED)
SURVEY MPC LID FOR HOT PARTICLES	3	3A	1	37.6	1.9	1.9	TELESCOPING DETECTOR USED
VERIFY MPC LID IS SEATED	0.5	3A	1	37.6	0.3	0.3	VISUAL VERIFICATION FROM 3 METERS
INSTALL LID RETENTION SYSTEM BOLTS	6	3B	2	90.3	9.0	18.1	24 BOLTS @ 2/PERSON-MINUTE
REMOVE HI-TRAC FROM SPENT FUEL POOL	8.5	3C	1	837.0	118.6	118.6	17 FEET @ 2 FT/MIN (CRANE SPEED)
DECONTAMINATE HI-TRAC BOTTOM	10	3D	1	554.8	92.5	92.5	LONG HANDLED TOOLS, PRELIMINARY DECON
TAKE SMEARS OF HI-TRAC EXTERIOR SURFACES	5	5B	1	1091.9	91.0	91.0	50 SMEARS @ 10 SMEARS/MINUTE
DISCONNECT ANNULUS OVERPRESSURE SYSTEM	0.5	5C	1	282.1	2.4	2.4	QUICK DISCONNECT COUPLING
SET HI-TRAC IN CASK PREPARATION AREA	10	4A	1	90.3	15.1	15.1	100 FT @ 10 FT/MIN (CRANE SPEED)
REMOVE NEUTRON SHIELD JACKET FILL PLUG	2	4A	1	90.3	3.0	3.0	SINGLE PLUG, NO SPECIAL TOOLS
INSTALL NEUTRON SHIELD JACKET FILL PLUG	2	5B	1	1091.9	36.4	36.4	SINGLE PLUG, NO SPECIAL TOOLS
DISCONNECT LID RETENTION SYSTEM	6	5A	2	69.8	7.0	14.0	24 BOLTS @ 2 BOLT/PERSON MINUTES

[†] See notes at bottom of Table 10.3.4.

Table 10.3.1b
HI-STORM 100 SYSTEM LOADING OPERATIONS USING THE 100-TON HI-TRAC TRANSFER CASK
ESTIMATED OPERATIONAL EXPOSURES[†] (60,000 MWD/MTU, 3-YEAR COOLED PWR FUEL)

ACTION	DURATION (MINUTES)	OPERATOR LOCATION (FIGURE 10.3.1)	NUMBER OF OPERATORS	DOSE RATE AT OPERATOR LOCATION (MREM/HR)	DOSE TO INDIVIDUAL (MREM)	TOTAL DOSE (PERSON-MREM)	ASSUMPTIONS
MEASURE DOSE RATES AT MPC LID	3	5A	1	69.8	3.5	3.5	TELESCOPING DETECTOR USED
DECONTAMINATE AND SURVEY HI-TRAC	103	5B	1	1091.9	1874.4	1874.4	490 SQ-FT@5 SQ-FT/PERSON-MINUTE+50 SMEARS@10 SMEARS/MINUTE
INSTALL TEMPORARY SHIELD	16	6A	2	34.2	9.1	18.2	8 SEGMENTS @ 1 SEGMENT/PERSON MIN
FILL TEMPORARY SHIELD RING	25	6A	1	34.2	14.3	14.3	230 GAL @10GPM, LONG HANDLED SPRAY WAND
ATTACH DRAIN LINE TO HI-TRAC DRAIN PORT	0.5	5C	1	282.1	2.4	2.4	QUICK DISCONNECT COUPLING
INSTALL RVOAs	2	6A	1	34.2	1.1	1.1	SINGLE THREADED CONNECTION X 2 RVOAs
ATTACH WATER PUMP TO DRAIN PORT	2	6A	1	34.2	1.1	1.1	POSITION PUMP SELF PRIMING
DISCONNECT WATER PUMP	5	6A	1	34.2	2.9	2.9	DRAIN HOSES MOVE PUMP
DECONTAMINATE MPC LID TOP SURFACE AND SHELL AREA ABOVE INFLATABLE ANNULUS SEAL	6	6A	1	34.2	3.4	3.4	30 SQ-FT @5 SQ-FT/MINUTE+10 SMEARS@10 SMEARS/MINUTE
REMOVE INFLATABLE ANNULUS SEAL	3	6A	1	34.2	1.7	1.7	SEAL PULLS OUT DIRECTLY
SURVEY MPC LID TOP SURFACES AND ACCESSIBLE AREAS OF TOP THREE INCHES OF MPC SHELL	1	6A	1	34.2	0.6	0.6	10 SMEARS@10 SMEARS/MINUTE
INSTALL ANNULUS SHIELD	2	6A	1	34.2	1.1	1.1	SHIELD PLACED BY HAND
CENTER LID IN MPC SHELL	20	6A	3	34.2	11.4	34.2	CONSULTATION WITH CALVERT CLIFFS
INSTALL MPC LID SHIMS	12	6A	2	34.2	6.8	13.7	MEASURED DURING WELD MOCKUP TESTING
POSITION AWS BASEPLATE SHIELD ON MPC LID	20	7A	2	34.2	11.4	22.8	ALIGN AND REMOVE 4 SHACKLES
INSTALL AUTOMATED WELDING SYSTEM ROBOT	8	7A	2	34.2	4.6	9.1	ALIGN AND REMOVE 4 SHACKLES/4 QUICK CONNECTS@1/MIN
PERFORM NDE ON LID WELD	230	7A	1	34.2	131.1	131.1	MEASURED DURING WELD MOCKUP TESTING

HOLTEC INTERNATIONAL COPYRIGHTED MATERIAL

Table 10.3.1b
HI-STORM 100 SYSTEM LOADING OPERATIONS USING THE 100-TON HI-TRAC TRANSFER CASK
ESTIMATED OPERATIONAL EXPOSURES[†] (60,000 MWD/MTU, 3-YEAR COOLED PWR FUEL)

ACTION	DURATION (MINUTES)	OPERATOR LOCATION (FIGURE 10.3.1)	NUMBER OF OPERATORS	DOSE RATE AT OPERATOR LOCATION (MREM/HR)	DOSE TO INDIVIDUAL (MREM)	TOTAL DOSE (PERSON-MREM)	ASSUMPTIONS
ATTACH DRAIN LINE TO VENT PORT	1	7A	1	34.2	0.6	0.6	1" THREADED FITTING NO TOOLS
VISUALLY EXAMINE MPC LID-TO-SHELL WELD FOR LEAKAGE OF WATER	10	7A	1	34.2	5.7	5.7	10 MIN TEST DURATION
DISCONNECT WATER FILL LINE AND DRAIN LINE	2	7A	1	34.2	1.1	1.1	1" THREADED FITTING NO TOOLS X 2
REPEAT LIQUID PENETRANT EXAMINATION ON MPC LID FINAL PASS	45	7A	1	34.2	25.7	25.7	5 MIN TO APPLY, 7 MIN TO WIPE, 5 APPLY DEV, INSP (24 IN/MIN)
ATTACH GAS SUPPLY TO VENT PORT	1	7A	1	34.2	0.6	0.6	1" THREADED FITTING NO TOOLS
ATTACH DRAIN LINE TO DRAIN PORT	1	7A	1	34.2	0.6	0.6	1" THREADED FITTING NO TOOLS
Deleted							
Deleted							
ATTACH DRAIN LINE TO VENT PORT	1	8A	1	79.5	1.3	1.3	1" THREADED FITTING NO TOOLS
ATTACH WATER FILL LINE TO DRAIN PORT	1	8A	1	79.5	1.3	1.3	1" THREADED FITTING NO TOOLS
DISCONNECT WATER FILL DRAIN LINES FROM MPC	2	8A	1	79.5	2.7	2.7	1" THREADED FITTING NO TOOLS X 2
ATTACH HELIUM SUPPLY TO VENT PORT	1	8A	1	79.5	1.3	1.3	1" THREADED FITTING NO TOOLS
ATTACH DRAIN LINE TO DRAIN PORT	1	8A	1	79.5	1.3	1.3	1" THREADED FITTING NO TOOLS
DISCONNECT GAS SUPPLY LINE FROM MPC	1	8A	1	79.5	1.3	1.3	1" THREADED FITTING NO TOOLS
DISCONNECT DRAIN LINE FROM MPC	1	8A	1	79.5	1.3	1.3	1" THREADED FITTING NO TOOLS
ATTACH MOISTURE REMOVAL SYSTEM () TO VENT AND DRAIN PORT RVOAs	2	8A	1	79.5	2.7	2.7	1" THREADED FITTING NO TOOLS
DISCONNECT MOISTURE REMOVAL SYSTEM FROM MPC	2	8A	1	79.5	2.7	2.7	1" THREADED FITTING NO TOOLS X 2
CLOSE DRAIN PORT RVOA CAP AND REMOVE DRAIN PORT RVOA	1.5	8A	1	79.5	2.0	2.0	SINGLE THREADED CONNECTION (1 RVOA)

HOLTEC INTERNATIONAL COPYRIGHTED MATERIAL

**Table 10.3.1b
HI-STORM 100 SYSTEM LOADING OPERATIONS USING THE 100-TON HI-TRAC TRANSFER CASK
ESTIMATED OPERATIONAL EXPOSURES[†] (60,000 MWD/MTU, 3-YEAR COOLED PWR FUEL)**

ACTION	DURATION (MINUTES)	OPERATOR LOCATION (FIGURE 10.3.1)	NUMBER OF OPERATORS	DOSE RATE AT OPERATOR LOCATION (MREM/HR)	DOSE TO INDIVIDUAL (MREM)	TOTAL DOSE (PERSON-MREM)	ASSUMPTIONS
ATTACH HELIUM BACKFILL SYSTEM TO VENT PORT	1	8A	1	79.5	1.3	1.3	1" THREADED FITTING NO TOOLS
DISCONNECT HBS FROM MPC	1	8A	1	79.5	1.3	1.3	1" THREADED FITTING NO TOOLS
CLOSE VENT PORT RVOA AND DISCONNECT VENT PORT RVOA	1.5	8A	1	79.5	2.0	2.0	SINGLE THREADED CONNECTION (1 RVOA)
WIPE INSIDE AREA OF VENT AND DRAIN PORT RECESSES	2	8A	1	79.5	2.7	2.7	2 PORTS, 1 MIN/PORT
PLACE COVER PLATE OVER VENT PORT RECESS	1	8A	1	79.5	1.3	1.3	INSTALLED BY HAND NO TOOLS (2/MIN)
PERFORM NDE VENT AND DRAIN COVER PLATE WELD	100	8A	1	79.5	132.5	132.5	MEASURED DURING WELD MOCKUP TESTING
FLUSH CAVITY WITH HELIUM AND INSTALL SET SCREWS	2	8A	1	79.5	2.7	2.7	4 SET SCREWS @2/MINUTE
PLUG WELD OVER ET SCREWS	8	8A	1	79.5	10.6	10.6	FOUR SINGLE SPOT WELDS @ 1 PER 2 MINUTES
INSTALL MSLD OVER VENT PORT COVER PLATE	2	8A	1				INSTALLED BY HAND, NO TOOLS
INSTALL MSLD OVER DRAIN PORT COVER PLATE	2	8A	1				INSTALLED BY HAND, NO TOOLS
INSTALL AND ALIGN CLOSURE RING	5	8A	1	79.5	6.6	6.6	INSTALLED BY HAND NO TOOLS
PERFORM NDE ON CLOSURE RING WELDS	185	8A	1	79.5	245.1	245.1	MEASURED DURING WELD MOCKUP TESTING
RIG AWS TO CRANE	12	8A	1	79.5	15.9	15.9	10 MIN TO DISCONNECT LINES, 4 SHACKLES@2/MIN
Section 8.1.6							
REMOVE ANNULUS SHIELD	1	8A	1	79.5	1.3	1.3	SHIELD PLACED BY HAND
ATTACH DRAIN LINE TO HI-TRAC	1	9D	1	2190.1	36.5	36.5	1" THREADED FITTING NO TOOLS
POSITION HI-TRAC TOP LID	10	9B	2	79.5	13.3	26.5	VERTICAL FLANGED CONNECTION
TORQUE TOP LID BOLTS	12	9B	1	79.5	15.9	15.9	24 BOLTS AT 2/MIN (INSTALL AND TORQUE, 1 PASS)
INSTALL MPC LIFT CLEATS AND MPC SLINGS	25	9A	2	363.8	151.6	303.2	INSTALL CLEATS AND HYDRO TORQUE 4 BOLTS
REMOVE TEMPORARY SHIELD RING DRAIN PLUGS	1	9B	1	79.5	1.3	1.3	8 PLUGS @ 8/MIN
REMOVE TEMPORARY SHIELD RING SEGMENTS	4	9A	1	363.8	24.3	24.3	REMOVED BY HAND NO TOOLS (8 SEGS@2/MIN)

HOLTEC INTERNATIONAL COPYRIGHTED MATERIAL

Table 10.3.1b
HI-STORM 100 SYSTEM LOADING OPERATIONS USING THE 100-TON HI-TRAC TRANSFER CASK
ESTIMATED OPERATIONAL EXPOSURES[†] (60,000 MWD/MTU, 3-YEAR COOLED PWR FUEL)

ACTION	DURATION (MINUTES)	OPERATOR LOCATION (FIGURE 10.3.1)	NUMBER OF OPERATORS	DOSE RATE AT OPERATOR LOCATION (MREM/HR)	DOSE TO INDIVIDUAL (MREM)	TOTAL DOSE (PERSON-MREM)	ASSUMPTIONS
ATTACH MPC SLINGS TO LIFT YOKE	4	9A	2	363.8	24.3	48.5	INSTALLED BY HAND NO TOOLS
POSITION HI-TRAC ABOVE TRANSFER STEP	15	9C	1	900.9	225.2	225.2	100 FT @ 10 FT/MIN (CRANE SPEED)+ 5MIN TO ALIGN
REMOVE BOTTOM LID BOLTS	6	10A	1	2190.1	219.0	219.0	36 BOLTS@6 BOLTS/MIN IMPACT TOOLS USED
INSTALL TRANSFER LID BOLTS	18	11B	1	2190.1	657.0	657.0	36 BOLTS @ 2/MIN IMPACT TOOLS USED 1 PASS
DISCONNECT MPC SLINGS	4	9A	2	363.8	24.3	48.5	INSTALLED BY HAND NO TOOLS
Section 8.1.7							
POSITION HI-TRAC ON TRANSPORT DEVICE	20	11A	2	900.9	300.3	600.6	ALIGN TRUNNIONS, DISCONNECT LIFT YOKE
TRANSPORT HI-TRAC TO OUTSIDE TRANSFER LOCATION	90	12A	3	35.2	52.8	158.4	DRIVER AND 2 SPOTTERS
ATTACH OUTSIDE LIFTING DEVICE LIFT LINKS	2	12A	2	35.2	1.2	2.3	2 LINKS@1/MIN
MATE OVERPACKS	10	13B	2	692.0	115.3	230.7	ALIGNMENT GUIDES USED
ATTACH MPC SLINGS TO MPC LIFT CLEATS	10	13A	2	363.8	60.6	121.3	2 SLINGS@5MIN/SLING NO TOOLS
REMOVE TRANSFER LID DOOR LOCKING PINS AND OPEN DOORS	4	13B	2	692.0	46.1	92.3	2 PINS@2MIN/PIN
INSTALL TRIM PLATES	4	13B	2	692.0	46.1	92.3	INSTALLED BY HAND
DISCONNECT SLINGS FROM MPC LIFTING DEVICE	10	13A	2	363.8	60.6	121.3	2 SLINGS@5MIN/SLING
REMOVE MPC LIFT CLEATS AND MPC SLINGS	10	14A	1	487.4	81.2	81.2	4 BOLTS,NO TORQUING
INSTALL HOLE PLUGS IN EMPTY MPC BOLT HOLES	2	14A	1	487.4	16.2	16.2	4 PLUGS AT 2/MIN NO TORQUING
REMOVE HI-STORM VENT DUCT SHIELD INSERTS	2	15A	1	43.9	1.5	1.5	4 SHACKLES@2/MIN
REMOVE ALIGNMENT DEVICE	4	15A	1	43.9	2.9	2.9	REMOVED BY HAND NO TOOLS (4 PCS@1/MIN)
INSTALL HI-STORM LID AND INSTALL LID STUDS/NUTS	25	16A	2	11.7	4.9	9.8	INSTALL LID AND HYDRO TORQUE 4 BOLTS
INSTALL HI-STORM EXIT VENT GAMMA SHIELD CROSS PLATES	4	16B	1	205.5	13.7	13.7	4 PCS @ 1/MIN INSTALL BY HAND NO TOOLS

HOLTEC INTERNATIONAL COPYRIGHTED MATERIAL

Table 10.3.1b
HI-STORM 100 SYSTEM LOADING OPERATIONS USING THE 100-TON HI-TRAC TRANSFER CASK
ESTIMATED OPERATIONAL EXPOSURES[†] (60,000 MWD/MTU, 3-YEAR COOLED PWR FUEL)

ACTION	DURATION (MINUTES)	OPERATOR LOCATION (FIGURE 10.3.1)	NUMBER OF OPERATORS	DOSE RATE AT OPERATOR LOCATION (MREM/HR)	DOSE TO INDIVIDUAL (MREM)	TOTAL DOSE (PERSON-MREM)	ASSUMPTIONS
INSTALL TEMPERATURE ELEMENTS	20	16B	1	205.5	68.5	68.5	4@5MIN/TEMPERATURE ELEMENT
INSTALL EXIT VENT SCREENS	20	16B	1	205.5	68.5	68.5	4 SCREENS@5MIN/SCREEN
REMOVE HI-STORM LID LIFTING DEVICE	2	16A	1	11.7	0.4	0.4	4 SHACKLES@2/MIN
INSTALL HOLE PLUGS IN EMPTY HOLES	2	16A	1	11.7	0.4	0.4	4 PLUGS AT 2/MIN NO TORQUING
PERFORM SHIELDING EFFECTIVENESS TESTING	16	16D	2	122.7	32.7	65.4	16 POINTS@1 MIN
SECURE HI-STORM TO TRANSPORT DEVICE	10	16A	2	11.7	2.0	3.9	ASSUMES AIR PAD
TRANSFER HI-STORM TO ITS DESIGNATED STORAGE LOCATION	40	16C	1	69.7	46.5	46.5	200 FEET @ 4FT/MIN
INSERT HI-STORM LIFTING JACKS	4	16D	1	122.7	8.2	8.2	4 JACKS@1/MIN
REMOVE AIR PAD	5	16D	2	122.7	10.2	20.5	1 PAD MOVED BY HAND
REMOVE HI-STORM LIFTING JACKS	4	16D	1	122.7	8.2	8.2	4 JACKS@1/MIN
INSTALL INLET VENT SCREENS/CROSS PLATES	20	16D	1	122.7	40.9	40.9	4 SCREENS@5MIN/SCREEN
PERFORM AIR TEMPERATURE RISE TEST	8	16B	1	205.5	27.4	27.4	8 MEASUREMENTS@1/MIN
TOTAL						6628.4 PERSON-MREM	

HOLTEC INTERNATIONAL COPYRIGHTED MATERIAL

HI-STORM FSAR
 REPORT HI-2002444

10.3-15

Rev. 7

HI-STORM 100 FSAR, NON-PROPRIETARY
 REVISION 12
 MARCH 12, 2014

Table 10.3.1c
HI-STORM 100 SYSTEM LOADING OPERATIONS USING THE 125-TON HI-TRAC 125D TRANSFER CASK
ESTIMATED OPERATIONAL EXPOSURES[†] (75,000 MWD/MTU, 5-YEAR COOLED PWR FUEL)

ACTION	DURATION (MINUTES)	OPERATOR LOCATION (FIGURE 10.3.1)	NUMBER OF OPERATORS	DOSE RATE AT OPERATOR LOCATION (MREM/HR)	DOSE TO INDIVIDUAL (MREM)	TOTAL DOSE (PERSON-MREM)	ASSUMPTIONS
Section 8.1.4							
LOAD PRE-SELECTED FUEL ASSEMBLIES INTO MPC	1020	1	2	1.0	17.0	34.0	15 MINUTES PER ASSEMBLY/68 ASSY
PERFORM POST-LOADING VISUAL VERIFICATION OF ASSEMBLY IDENTIFICATION	68	1	2	1.0	1.1	2.3	1 MINUTES PER ASSY/68 ASSY
Section 8.1.5							
INSTALL MPC LID AND ATTACH LIFT YOKE	45	2	2	2.0	1.5	3.0	CONSULTATION WITH CALVERT CLIFFS
RAISE HI-TRAC TO SURFACE OF SPENT FUEL POOL	20	2	2	2.0	0.7	1.3	40 FEET @ 2 FT/MINUTE (CRANE SPEED)
SURVEY MPC LID FOR HOT PARTICLES	3	3A	1	31.1	1.6	1.6	TELESCOPING DETECTOR USED
VERIFY MPC LID IS SEATED	0.5	3A	1	31.1	0.3	0.3	VISUAL VERIFICATION FROM 3 METERS
INSTALL LID RETENTION SYSTEM BOLTS	6	3B	2	46.4	4.6	9.3	24 BOLTS @ 2/PERSON-MINUTE
REMOVE HI-TRAC FROM SPENT FUEL POOL	8.5	3C	1	117.8	16.7	16.7	17 FEET @ 2 FT/MIN (CRANE SPEED)
DECONTAMINATE HI-TRAC BOTTOM	10	3D	1	142.0	23.7	23.7	LONG HANDLED TOOLS, PRELIMINARY DECON
TAKE SMEARS OF HI-TRAC EXTERIOR SURFACES	5	5B	1	185.3	15.4	15.4	50 SMEARS @ 10 SMEARS/MINUTE
DISCONNECT ANNULUS OVERPRESSURE SYSTEM	0.5	5C	1	82.7	0.7	0.7	QUICK DISCONNECT COUPLING
SET HI-TRAC IN CASK PREPARATION AREA	10	4A	1	46.4	7.7	7.7	100 FT @ 10 FT/MIN (CRANE SPEED)
REMOVE NEUTRON SHIELD JACKET FILL PLUG	2	4A	1	46.4	1.5	1.5	SINGLE PLUG, NO SPECIAL TOOLS
INSTALL NEUTRON SHIELD JACKET FILL PLUG	2	5B	1	185.3	6.2	6.2	SINGLE PLUG, NO SPECIAL TOOLS
DISCONNECT LID RETENTION SYSTEM	6	5A	2	37.3	3.7	7.5	24 BOLTS @ 2 BOLT/PERSON MINUTES

[†] See notes at bottom of Table 10.3.4.

Table 10.3.1c
HI-STORM 100 SYSTEM LOADING OPERATIONS USING THE 125-TON HI-TRAC 125D TRANSFER CASK
ESTIMATED OPERATIONAL EXPOSURES[†] (75,000 MWD/MTU, 5-YEAR COOLED PWR FUEL)

ACTION	DURATION (MINUTES)	OPERATOR LOCATION (FIGURE 10.3.1)	NUMBER OF OPERATORS	DOSE RATE AT OPERATOR LOCATION (MREM/HR)	DOSE TO INDIVIDUAL (MREM)	TOTAL DOSE (PERSON-MREM)	ASSUMPTIONS
MEASURE DOSE RATES AT MPC LID	3	5A	1	37.3	1.9	1.9	TELESCOPING DETECTOR USED
DECONTAMINATE AND SURVEY HI-TRAC	103	5B	1	185.3	318.1	318.1	490 SQ-FT@5 SQ-FT/PERSON-MINUTE+50 SMEARS@10 SMEARS/MINUTE
INSTALL TEMPORARY SHIELD	16	6A	2	18.7	5.0	10.0	8 SEGMENTS @ 1 SEGMENT/PERSON MIN
FILL TEMPORARY SHIELD RING	25	6A	1	18.7	7.8	7.8	230 GAL @10GPM, LONG HANDLED SPRAY WAND
ATTACH DRAIN LINE TO HI-TRAC DRAIN PORT	0.5	5C	1	82.7	0.7	0.7	QUICK DISCONNECT COUPLING
INSTALL RVOAs	2	6A	1	18.7	0.6	0.6	SINGLE THREADED CONNECTION X 2 RVOAs
ATTACH WATER PUMP TO DRAIN PORT	2	6A	1	18.7	0.6	0.6	POSITION PUMP SELF PRIMING
DISCONNECT WATER PUMP	5	6A	1	18.7	1.6	1.6	DRAIN HOSES MOVE PUMP
DECONTAMINATE MPC LID TOP SURFACE AND SHELL AREA ABOVE INFLATABLE ANNULUS SEAL	6	6A	1	18.7	1.9	1.9	30 SQ-FT @5 SQ-FT/MINUTE+10 SMEARS@10 SMEARS/MINUTE
REMOVE INFLATABLE ANNULUS SEAL	3	6A	1	18.7	0.9	0.9	SEAL PULLS OUT DIRECTLY
SURVEY MPC LID TOP SURFACES AND ACCESSIBLE AREAS OF TOP THREE INCHES OF MPC SHELL	1	6A	1	18.7	0.3	0.3	10 SMEARS@10 SMEARS/MINUTE
INSTALL ANNULUS SHIELD	2	6A	1	18.7	0.6	0.6	SHIELD PLACED BY HAND
CENTER LID IN MPC SHELL	20	6A	3	18.7	6.2	18.7	CONSULTATION WITH CALVERT CLIFFS
INSTALL MPC LID SHIMS	12	6A	2	18.7	3.7	7.5	MEASURED DURING WELD MOCKUP TESTING
POSITION AWS BASEPLATE SHIELD ON MPC LID	20	7A	2	18.7	6.2	12.5	ALIGN AND REMOVE 4 SHACKLES
INSTALL AUTOMATED WELDING SYSTEM ROBOT	8	7A	2	18.7	2.5	5.0	ALIGN AND REMOVE 4 SHACKLES/4 QUICK CONNECTS@1/MIN
PERFORM NDE OF LID WELD	230	7A	1	18.7	71.7	71.7	MEASURED DURING WELD MOCKUP TESTING
ATTACH DRAIN LINE TO VENT PORT	1	7A	1	18.7	0.3	0.3	1" THREADED FITTING NO TOOLS

HOLTEC INTERNATIONAL COPYRIGHTED MATERIAL

Table 10.3.1c
HI-STORM 100 SYSTEM LOADING OPERATIONS USING THE 125-TON HI-TRAC 125D TRANSFER CASK
ESTIMATED OPERATIONAL EXPOSURES[†] (75,000 MWD/MTU, 5-YEAR COOLED PWR FUEL)

ACTION	DURATION (MINUTES)	OPERATOR LOCATION (FIGURE 10.3.1)	NUMBER OF OPERATORS	DOSE RATE AT OPERATOR LOCATION (MREM/HR)	DOSE TO INDIVIDUAL (MREM)	TOTAL DOSE (PERSON-MREM)	ASSUMPTIONS
VISUALLY EXAMINE MPC LID-TO-SHELL WELD FOR LEAKAGE OF WATER	10	7A	1	18.7	3.1	3.1	10 MIN TEST DURATION
DISCONNECT WATER FILL LINE AND DRAIN LINE	2	7A	1	18.7	0.6	0.6	1" THREADED FITTING NO TOOLS X 2
REPEAT LIQUID PENETRANT EXAMINATION ON MPC LID FINAL PASS	45	7A	1	18.7	14.0	14.0	5 MIN TO APPLY, 7 MIN TO WIPE, 5 APPLY DEV, INSP (24 IN/MIN)
ATTACH GAS SUPPLY TO VENT PORT	1	7A	1	18.7	0.3	0.3	1" THREADED FITTING NO TOOLS
ATTACH DRAIN LINE TO DRAIN PORT	1	7A	1	18.7	0.3	0.3	1" THREADED FITTING NO TOOLS
Deleted							
Deleted							
ATTACH DRAIN LINE TO VENT PORT	1	8A	1	37.9	0.6	0.6	1" THREADED FITTING NO TOOLS
ATTACH WATER FILL LINE TO DRAIN PORT	1	8A	1	37.9	0.6	0.6	1" THREADED FITTING NO TOOLS
DISCONNECT WATER FILL DRAIN LINES FROM MPC	2	8A	1	37.9	1.3	1.3	1" THREADED FITTING NO TOOLS X 2
ATTACH HELIUM SUPPLY TO VENT PORT	1	8A	1	37.9	0.6	0.6	1" THREADED FITTING NO TOOLS
ATTACH DRAIN LINE TO DRAIN PORT	1	8A	1	37.9	0.6	0.6	1" THREADED FITTING NO TOOLS
DISCONNECT GAS SUPPLY LINE FROM MPC	1	8A	1	37.9	0.6	0.6	1" THREADED FITTING NO TOOLS
DISCONNECT DRAIN LINE FROM MPC	1	8A	1	37.9	0.6	0.6	1" THREADED FITTING NO TOOLS
ATTACH MOISTURE REMOVAL SYSTEM TO VENT AND DRAIN PORT RVOAs	2	8A	1	37.9	1.3	1.3	1" THREADED FITTING NO TOOLS
DISCONNECT MOISTURE REMOVAL SYSTEM FROM MPC	2	8A	1	37.9	1.3	1.3	1" THREADED FITTING NO TOOLS X 2

HOLTEC INTERNATIONAL COPYRIGHTED MATERIAL

Table 10.3.1c
HI-STORM 100 SYSTEM LOADING OPERATIONS USING THE 125-TON HI-TRAC 125D TRANSFER CASK
ESTIMATED OPERATIONAL EXPOSURES[†] (75,000 MWD/MTU, 5-YEAR COOLED PWR FUEL)

ACTION	DURATION (MINUTES)	OPERATOR LOCATION (FIGURE 10.3.1)	NUMBER OF OPERATORS	DOSE RATE AT OPERATOR LOCATION (MREM/HR)	DOSE TO INDIVIDUAL (MREM)	TOTAL DOSE (PERSON-MREM)	ASSUMPTIONS
CLOSE DRAIN PORT RVOA CAP AND REMOVE DRAIN PORT RVOA	1.5	8A	1	37.9	0.9	0.9	SINGLE THREADED CONNECTION (1 RVOA)
ATTACH HELIUM BACKFILL SYSTEM TO VENT PORT	1	8A	1	37.9	0.6	0.6	1" THREADED FITTING NO TOOLS
DISCONNECT HBS FROM MPC	1	8A	1	37.9	0.6	0.6	1" THREADED FITTING NO TOOLS
CLOSE VENT PORT RVOA AND DISCONNECT VENT PORT RVOA	1.5	8A	1	37.9	0.9	0.9	SINGLE THREADED CONNECTION (1 RVOA)
WIPE INSIDE AREA OF VENT AND DRAIN PORT RECESSES	2	8A	1	37.9	1.3	1.3	2 PORTS, 1 MIN/PORT
PLACE COVER PLATE OVER VENT PORT RECESS	1	8A	1	37.9	0.6	0.6	INSTALLED BY HAND NO TOOLS (2/MIN)
PERFORM NDE ON VENT AND DRAIN COVER PLATE WELD	100	8A	1	37.9	63.2	63.2	MEASURED DURING WELD MOCKUP TESTING
INSTALL SET SCREWS	2	8A	1	37.9	1.3	1.3	4 SET SCREWS @2/MINUTE
PLUG WELD OVER SET SCREWS	8	8A	1	37.9	5.1	5.1	FOUR SINGLE SPOT WELDS @ 1 PER 2 MINTES
Deleted							
Deleted							
INSTALL AND ALIGN CLOSURE RING	5	8A	1	37.9	3.2	3.2	INSTALLED BY HAND NO TOOLS
PERFORM A NDE ON CLOSURE RING WELDS	185	8A	1	37.9	116.9	116.9	MEASURED DURING WELD MOCKUP TESTING
RIG AWS TO CRANE	12	8A	1	37.9	7.6	7.6	10 MIN TO DISCONNECT LINES, 4 SHACKLES@2/MIN
Section 8.1.6							
REMOVE ANNULUS SHIELD	1	8A	1	37.9	0.6	0.6	SHIELD PLACED BY HAND
ATTACH DRAIN LINE TO HI-TRAC	1	9D	1	354.2	5.9	5.9	1" THREADED FITTING NO TOOLS
POSITION HI-TRAC TOP LID	10	9B	2	37.9	6.3	12.6	VERTICAL FLANGED CONNECTION
TORQUE TOP LID BOLTS	12	9B	1	37.9	7.6	7.6	24 BOLTS AT 2/MIN (INSTALL AND TORQUE, 1 PASS)

HOLTEC INTERNATIONAL COPYRIGHTED MATERIAL

Table 10.3.1c
HI-STORM 100 SYSTEM LOADING OPERATIONS USING THE 125-TON HI-TRAC 125D TRANSFER CASK
ESTIMATED OPERATIONAL EXPOSURES[†] (75,000 MWD/MTU, 5-YEAR COOLED PWR FUEL)

ACTION	DURATION (MINUTES)	OPERATOR LOCATION (FIGURE 10.3.1)	NUMBER OF OPERATORS	DOSE RATE AT OPERATOR LOCATION (MREM/HR)	DOSE TO INDIVIDUAL (MREM)	TOTAL DOSE (PERSON-MREM)	ASSUMPTIONS
INSTALL MPC LIFT CLEATS AND MPC SLINGS	25	9A	2	158.5	66.0	132.1	INSTALL CLEATS AND HYDRO TORQUE 4 BOLTS
REMOVE TEMPORARY SHIELD RING DRAIN PLUGS	1	9B	1	37.9	0.6	0.6	8 PLUGS @ 8/MIN
REMOVE TEMPORARY SHIELD RING SEGMENTS	4	9A	1	158.5	10.6	10.6	REMOVED BY HAND NO TOOLS (8 SEGS@2/MIN)
ATTACH MPC SLINGS TO LIFT YOKE	4	9A	2	158.5	10.6	21.1	INSTALLED BY HAND, NO TOOLS
Section 8.1.7							
POSITION HI-TRAC ON TRANSPORT DEVICE	20	11A	2	117.8	39.3	78.5	ALIGN TRUNNIONS, DISCONNECT LIFT YOKE
TRANSPORT HI-TRAC TO OUTSIDE TRANSFER LOCATION	90	12A	3	26.4	39.6	118.8	DRIVER AND 2 SPOTTERS
ATTACH OUTSIDE LIFTING DEVICE LIFT LINKS	2	12A	2	26.4	0.9	1.8	2 LINKS@1/MIN
MATE OVERPACKS	10	13B	2	118.5	19.8	39.5	ALIGNMENT GUIDES USED
ATTACH MPC LIFT SLINGS TO MPC LIFT CLEATS	10	13A	2	158.5	26.4	52.8	2 SLINGS@5MIN/SLING NO TOOLS
REMOVE MATING DEVICE LOCKING PINS AND OPEN DRAWER	40	13B	2	118.5	79.0	158.0	2 PINS@2MIN/PIN
INSTALL TRIM PLATES	4	13B	2	118.5	7.9	15.8	INSTALLED BY HAND
DISCONNECT SLINGS FROM MPC LIFTING DEVICE	10	13A	2	158.5	26.4	52.8	2 SLINGS@5MIN/SLING
REMOVE MPC LIFT CLEATS AND MPC LIFT SLINGS	10	14A	1	487.4	81.2	81.2	4 BOLTS,NO TORQUING
INSTALL HOLE PLUGS IN EMPTY MPC BOLT HOLES	2	14A	1	487.4	16.2	16.2	4 PLUGS AT 2/MIN NO TORQUING
REMOVE HI-STORM VENT DUCT SHIELD INSERTS	2	15A	1	43.9	1.5	1.5	4 SHACKLES@2/MIN
REMOVE MATING DEVICE	10	15A	1	43.9	7.3	7.3	3 BOLTS @ 2 MINUTES PER BOLT
INSTALL HI-STORM LID AND INSTALL LID STUDS/NUTS	25	16A	2	11.7	4.9	9.8	INSTALL LID AND HYDRO TORQUE 4 BOLTS

HOLTEC INTERNATIONAL COPYRIGHTED MATERIAL

Table 10.3.1c
HI-STORM 100 SYSTEM LOADING OPERATIONS USING THE 125-TON HI-TRAC 125D TRANSFER CASK
ESTIMATED OPERATIONAL EXPOSURES[†] (75,000 MWD/MTU, 5-YEAR COOLED PWR FUEL)

ACTION	DURATION (MINUTES)	OPERATOR LOCATION (FIGURE 10.3.1)	NUMBER OF OPERATORS	DOSE RATE AT OPERATOR LOCATION (MREM/HR)	DOSE TO INDIVIDUAL (MREM)	TOTAL DOSE (PERSON-MREM)	ASSUMPTIONS
INSTALL HI-STORM EXIT VENT GAMMA SHIELD CROSS PLATES	4	16B	1	205.5	13.7	13.7	4 PCS @ 1/MIN INSTALL BY HAND NO TOOLS
INSTALL TEMPERATURE ELEMENTS	20	16B	1	205.5	68.5	68.5	4@5MIN/TEMPERATURE ELEMENT
INSTALL EXIT VENT SCREENS	20	16B	1	205.5	68.5	68.5	4 SCREENS@5MIN/SCREEN
REMOVE HI-STORM LID LIFTING DEVICE	2	16A	1	11.7	0.4	0.4	4 SHACKLES@2/MIN
INSTALL HOLE PLUGS IN EMPTY HOLES	2	16A	1	11.7	0.4	0.4	4 PLUGS AT 2/MIN NO TORQUING
PERFORM SHIELDING EFFECTIVENESS TESTING	16	16D	2	122.7	32.7	65.4	16 POINTS@1 MIN
SECURE HI-STORM TO TRANSPORT DEVICE	10	16A	2	11.7	2.0	3.9	ASSUMES AIR PAD
TRANSFER HI-STORM TO ITS DESIGNATED STORAGE LOCATION	40	16C	1	69.7	46.5	46.5	200 FEET @ 4FT/MIN
INSERT HI-STORM LIFTING JACKS	4	16D	1	122.7	8.2	8.2	4 JACKS@1/MIN
REMOVE AIR PAD	5	16D	2	122.7	10.2	20.5	1 PAD MOVED BY HAND
REMOVE HI-STORM LIFTING JACKS	4	16D	1	122.7	8.2	8.2	4 JACKS@1/MIN
INSTALL INLET VENT SCREENS/CROSS PLATES	20	16D	1	122.7	40.9	40.9	4 SCREENS@5MIN/SCREEN
PERFORM AIR TEMPERATURE RISE TEST	8	16B	1	205.5	27.4	27.4	8 MEASUREMENTS@1/MIN
TOTAL							2017.4 PERSON-MREM

HOLTEC INTERNATIONAL COPYRIGHTED MATERIAL

HI-STORM FSAR
 REPORT HI-2002444

10.3-21

Rev. 7

HI-STORM 100 FSAR, NON-PROPRIETARY
 REVISION 12
 MARCH 12, 2014

Table 10.3.2a
HI-STORM 100 SYSTEM UNLOADING OPERATIONS USING THE 125-TON HI-TRAC TRANSFER CASK
ESTIMATED OPERATIONAL EXPOSURES[†] (75,000 MWD/MTU, 5-YEAR COOLED PWR FUEL)

ACTION	DURATION (MINUTES)	OPERATOR LOCATION (FIGURE 10.3.1)	NUMBER OF OPERATORS	DOSE RATE AT OPERATOR LOCATION (MREM/HR)	DOSE TO INDIVIDUAL (MREM)	TOTAL DOSE (PERSON-MREM)	ASSUMPTIONS
Section 8.3.2 (Step Sequence Varies By Site and Mode of Transport)							
REMOVE INLET VENT SCREENS	20	16D	1	122.7	40.9	40.9	4 SCREENS@5MIN/SCREEN
INSERT HI-STORM LIFTING JACKS	4	16D	1	122.7	8.2	8.2	4 JACKS@1/MIN
INSERT AIR PAD	5	16D	2	122.7	10.2	20.5	1 PAD MOVED BY HAND
REMOVE HI-STORM LIFTING JACKS	4	16D	1	122.7	8.2	8.2	4 JACKS@1/MIN
TRANSFER HI-STORM TO MPC TRANSFER LOCATION	40	16C	1	69.7	46.5	46.5	200 FEET @ 4FT/MIN
REMOVE HI-STORM LID STUDS/NUTS	10	16A	1	11.7	2.0	2.0	4 BOLTS NO TORQUE
REMOVE HI-STORM LID LIFTING HOLE PLUGS AND INSTALL LID LIFTING SLING	2	16A	1	11.7	0.4	0.4	4 PLUGS AT 2/MIN NO TORQUING
REMOVE GAMMA SHIELD CROSS PLATES	4	16B	1	205.5	13.7	13.7	4 PLATES@1/MIN
REMOVE TEMPERATURE ELEMENTS	8	16B	1	205.5	27.4	27.4	4 TEMP. ELEMENTS @ 2MIN/TEMP. ELEMENT NO TORQUE
REMOVE HI-STORM LID	2	16A	1	11.7	0.4	0.4	4 SHACKLES@2/MIN
INSTALL HI-STORM VENT DUCT SHIELD INSERTS	2	15A	1	43.9	1.5	1.5	4 SHACKLES@2/MIN
INSTALL ALIGNMENT DEVICE	4	15A	1	43.9	2.9	2.9	REMOVED BY HAND NO TOOLS (4 PCS@1/MIN)
REMOVE MPC LIFT CLEAT HOLE PLUGS	2	14A	1	487.4	16.2	16.2	4 PLUGS AT 2/MIN NO TORQUING
INSTALL MPC LIFT CLEATS AND MPC SLINGS	2	14A	1	487.4	16.2	16.2	4 PLUGS AT 2/MIN NO TORQUING
ALIGN HI-TRAC OVER HI-STORM AND MATE OVERPACKS	10	13B	2	118.5	19.8	39.5	ALIGNMENT GUIDES USED
PULL MPC SLINGS THROUGH TOP LID HOLE	10	13A	2	158.5	26.4	52.8	2 SLINGS@5MIN/SLING
INSTALL TRIM PLATES	4	13B	2	118.5	7.9	15.8	INSTALLED BY HAND NO FASTENERS

[†] See notes at bottom of Table 10.3.4.

Table 10.3.2a
HI-STORM 100 SYSTEM UNLOADING OPERATIONS USING THE 125-TON HI-TRAC TRANSFER CASK
ESTIMATED OPERATIONAL EXPOSURES[†] (75,000 MWD/MTU, 5-YEAR COOLED PWR FUEL)

ACTION	DURATION (MINUTES)	OPERATOR LOCATION (FIGURE 10.3.1)	NUMBER OF OPERATORS	DOSE RATE AT OPERATOR LOCATION (MREM/HR)	DOSE TO INDIVIDUAL (MREM)	TOTAL DOSE (PERSON-MREM)	ASSUMPTIONS
ATTACH MPC SLING TO LIFTING DEVICE	10	13A	1	158.5	26.4	26.4	2 SLINGS@5MIN/SLING NO BOLTING
CLOSE HI-TRAC DOORS AND INSTALL DOOR LOCKING PINS	4	13B	2	118.5	7.9	15.8	2 PINS@2MIN/PIN
DISCONNECT SLINGS FROM MPC LIFT CLEATS	10	13A	2	158.5	26.4	52.8	2 SLINGS@5MIN/SLING
DOWNEND HI-TRAC ON TRANSPORT FRAME	20	12A	2	26.4	8.8	17.6	ALIGN TRUNNIONS, DISCONNECT LIFT YOKE
TRANSPORT HI-TRAC TO FUEL BUILDING	90	12A	1	26.4	39.6	39.6	DRIVER RECEIVES MOST DOSE
UPEND HI-TRAC	20	12A	2	26.4	8.8	17.6	ALIGN TRUNNIONS, DISCONNECT LIFT YOKE
Section 8.3.3							
MOVE HI-TRAC TO TRANSFER SLIDE	20	11A	2	117.8	39.3	78.5	ALIGN TRUNNIONS, DISCONNECT LIFT YOKE
ATTACH MPC SLINGS	4	9A	2	158.5	10.6	21.1	INSTALLED BY HAND NO TOOLS
REMOVE TRANSFER LID BOLTS	6	11B	1	354.2	35.4	35.4	36 BOLTS@6 BOLTS/MIN IMPACT TOOLS USED
INSTALL POOL LID BOLTS	18	10A	1	354.2	106.3	106.3	36 BOLTS @ 2/MIN IMPACT TOOLS USED 1 PASS
DISCONNECT MPC SLINGS AND LIFT CLEATS	10	9A	1	158.5	26.4	26.4	4 BOLTS,NO TORQUING
PLACE HI-TRAC IN PREPARATION AREA	15	9C	1	117.8	29.5	29.5	100 FT @ 10 FT/MIN (CRANE SPEED)+ 5MIN TO ALIGN
REMOVE TOP LID BOLTS	6	9B	1	37.9	3.8	3.8	24 BOLTS AT 4/MIN (NO TORQUE IMPACT TOOLS)
REMOVE HI-TRAC TOP LID	2	6A	1	18.7	0.6	0.6	4 SHACKLES@2/MIN
ATTACH WATER FILL LINE TO HI-TRAC DRAIN PORT	0.5	9D	1	354.2	3.0	3.0	QUICK DISCONNECT NO TOOLS
INSTALL BOLT PLUGS OR WATERPROOF TAPE FROM HI-TRAC TOP BOLT HOLES	9	8A	1	37.9	5.7	5.7	18 HOLES@2/MIN
CORE DRILL CLOSURE RING AND VENT AND DRAIN PORT COVER PLATES	40	7A	2	18.7	12.5	24.9	20 MINUTES TO INSTALL/ALIGN +10 MIN/COVER

HOLTEC INTERNATIONAL COPYRIGHTED MATERIAL

Table 10.3.2a
HI-STORM 100 SYSTEM UNLOADING OPERATIONS USING THE 125-TON HI-TRAC TRANSFER CASK
ESTIMATED OPERATIONAL EXPOSURES[†] (75,000 MWD/MTU, 5-YEAR COOLED PWR FUEL)

ACTION	DURATION (MINUTES)	OPERATOR LOCATION (FIGURE 10.3.1)	NUMBER OF OPERATORS	DOSE RATE AT OPERATOR LOCATION (MREM/HR)	DOSE TO INDIVIDUAL (MREM)	TOTAL DOSE (PERSON-MREM)	ASSUMPTIONS
REMOVE CLOSURE RING SECTION AND VENT AND DRAIN PORT COVER PLATES	1	8A	1	37.9	0.6	0.6	2 COVERS@2/MIN NO TOOLS
ATTACH RVOAs	2	8A	1	37.9	1.3	1.3	SINGLE THREADED CONNECTION (1 RVOA)
ATTACH A SAMPLE BOTTLE TO VENT PORT RVOA	0.5	8A	1	37.9	0.3	0.3	1" THREADED FITTING NO TOOLS
GATHER A GAS SAMPLE FROM MPC	0.5	8A	1	37.9	0.3	0.3	SMALL BALL VALVE
CLOSE VENT PORT CAP AND DISCONNECT SAMPLE BOTTLE	1	8A	1	37.9	0.6	0.6	1" THREADED FITTING NO TOOLS
ATTACH RE-FLOOD SYSTEM TO RVOAs	2	8A	1	37.9	1.3	1.3	1" THREADED FITTING NO TOOLS X 2
DISCONNECT RE-FLOOD LINES TO VENT AND DRAIN PORT RVOAs	1	8A	1	37.9	0.6	0.6	1" THREADED FITTING NO TOOLS
VACUUM TOP SURFACES OF MPC AND HI-TRAC	10	6A	1	18.7	3.1	3.1	SHOP VACUUM WITH WAND + HAND WIPE
REMOVE ANNULUS SHIELD	1	8A	1	37.9	0.6	0.6	SHIELD PLACED BY HAND
MANUALLY INSTALL INFLATABLE SEAL	10	6A	2	18.7	3.1	6.2	CONSULTATION WITH CALVERT CLIFFS
OPEN NEUTRON SHIELD JACKET DRAIN VALVE	2	5C	1	82.7	2.8	2.8	SINGLE THREADED CONNECTION
CLOSE NEUTRON SHIELD JACKET DRAIN VALVE	2	5C	1	82.7	2.8	2.8	SINGLE THREADED CONNECTION
REMOVE MPC LID LIFTING HOLE PLUGS	2	5A	1	37.3	1.2	1.2	4 PLUGS AT 2/MIN NO TORQUING
ATTACH LID RETENTION SYSTEM	12	5A	1	37.3	7.5	7.5	24 BOLTS @ 2 MINUTES/BOLT
ATTACH ANNULUS OVERPRESSURE SYSTEM	0.5	5C	1	82.7	0.7	0.7	QUICK DISCONNECT NO TOOLS
POSITION HI-TRAC OVER CASK LOADING AREA	10	5C	1	82.7	13.8	13.8	100 FT @ 10 FT/MIN (CRANE SPEED)
LOWER HI-TRAC INTO SPENT FUEL POOL	8.5	3C	1	117.8	16.7	16.7	17 FEET @ 2 FT/MIN (CRANE SPEED)
REMOVE LID RETENTION BOLTS	12	3B	1	46.4	9.3	9.3	24 BOLTS @ 2/MINUTE
PLACE HI-TRAC ON FLOOR	20	2	2	2.0	0.7	1.3	40 FEET @ 2 FT/MINUTE (CRANE SPEED)

HOLTEC INTERNATIONAL COPYRIGHTED MATERIAL

HI-STORM FSAR
 REPORT HI-2002444

10.3-24

Rev. 7

HI-STORM 100 FSAR, NON-PROPRIETARY
 REVISION 12
 MARCH 12, 2014

Table 10.3.2a
HI-STORM 100 SYSTEM UNLOADING OPERATIONS USING THE 125-TON HI-TRAC TRANSFER CASK
ESTIMATED OPERATIONAL EXPOSURES[†] (75,000 MWD/MTU, 5-YEAR COOLED PWR FUEL)

ACTION	DURATION (MINUTES)	OPERATOR LOCATION (FIGURE 10.3.1)	NUMBER OF OPERATORS	DOSE RATE AT OPERATOR LOCATION (MREM/HR)	DOSE TO INDIVIDUAL (MREM)	TOTAL DOSE (PERSON-MREM)	ASSUMPTIONS
REMOVE MPC LID	20	2	2	2.0	0.7	1.3	CONSULTATION WITH CALVERT CLIFFS
Section 8.3.4							
REMOVE SPENT FUEL ASSEMBLIES FROM MPC	1020	1	2	1.0	17.0	34.0	15 MINUTES PER ASSEMBLY/68 ASSY
TOTAL						924.4 PERSON-MREM	

HOLTEC INTERNATIONAL COPYRIGHTED MATERIAL

Table 10.3.2b
HI-STORM 100 SYSTEM UNLOADING OPERATIONS USING THE 100-TON HI-TRAC TRANSFER CASK
ESTIMATED OPERATIONAL EXPOSURES[†] (60,000 MWD/MTU, 3-YEAR COOLED PWR FUEL)

ACTION	DURATION (MINUTES)	OPERATOR LOCATION (FIGURE 10.3.1)	NUMBER OF OPERATORS	DOSE RATE AT OPERATOR LOCATION (MREM/HR)	DOSE TO INDIVIDUAL (MREM)	TOTAL DOSE (PERSON-MREM)	ASSUMPTIONS
Section 8.3.2 (Step Sequence Varies By Site and Mode of Transport)							
REMOVE INLET VENT SCREENS	20	16D	1	122.7	40.9	40.9	4 SCREENS@5MIN/SCREEN
INSERT HI-STORM LIFTING JACKS	4	16D	1	122.7	8.2	8.2	4 JACKS@1/MIN
INSERT AIR PAD	5	16D	2	122.7	10.2	20.5	1 PAD MOVED BY HAND
REMOVE HI-STORM LIFTING JACKS	4	16D	1	122.7	8.2	8.2	4 JACKS@1/MIN
TRANSFER HI-STORM TO MPC TRANSFER LOCATION	40	16C	1	69.7	46.5	46.5	200 FEET @ 4FT/MIN
REMOVE HI-STORM LID STUDS/NUTS	10	16A	1	11.7	2.0	2.0	4 BOLTS NO TORQUE
REMOVE HI-STORM LID LIFTING HOLE PLUGS AND INSTALL LID LIFTING SLING	2	16A	1	11.7	0.4	0.4	4 PLUGS AT 2/MIN NO TORQUING
REMOVE GAMMA SHIELD CROSS PLATES	4	16B	1	205.5	13.7	13.7	4 PLATES@1/MIN
REMOVE TEMPERATURE ELEMENTS	8	16B	1	205.5	27.4	27.4	4 TEMP. ELEMENTS @ 2MIN/TEMP. ELEMENT NO TORQUE
REMOVE HI-STORM LID	2	16A	1	11.7	0.4	0.4	4 SHACKLES@2/MIN
INSTALL HI-STORM VENT DUCT SHIELD INSERTS	2	15A	1	43.9	1.5	1.5	4 SHACKLES@2/MIN
INSTALL ALIGNMENT DEVICE	4	15A	1	43.9	2.9	2.9	REMOVED BY HAND NO TOOLS (4 PCS@1/MIN)
REMOVE MPC LIFT CLEAT HOLE PLUGS	2	14A	1	487.4	16.2	16.2	4 PLUGS AT 2/MIN NO TORQUING
INSTALL MPC LIFT CLEATS AND MPC SLINGS	2	14A	1	487.4	16.2	16.2	4 PLUGS AT 2/MIN NO TORQUING
ALIGN HI-TRAC OVER HI-STORM AND MATE OVERPACKS	10	13B	2	692.0	115.3	230.7	ALIGNMENT GUIDES USED
PULL MPC SLINGS THROUGH TOP LID HOLE	10	13A	2	363.8	60.6	121.3	2 SLINGS@5MIN/SLING
INSTALL TRIM PLATES	4	13B	2	692.0	46.1	92.3	INSTALLED BY HAND NO FASTENERS

[†] See notes at bottom of Table 10.3.4.

Table 10.3.2b
HI-STORM 100 SYSTEM UNLOADING OPERATIONS USING THE 100-TON HI-TRAC TRANSFER CASK
ESTIMATED OPERATIONAL EXPOSURES[†] (60,000 MWD/MTU, 3-YEAR COOLED PWR FUEL)

ACTION	DURATION (MINUTES)	OPERATOR LOCATION (FIGURE 10.3.1)	NUMBER OF OPERATORS	DOSE RATE AT OPERATOR LOCATION (MREM/HR)	DOSE TO INDIVIDUAL (MREM)	TOTAL DOSE (PERSON-MREM)	ASSUMPTIONS
ATTACH MPC SLING TO LIFTING DEVICE	10	13A	1	363.8	60.6	60.6	2 SLINGS@5MIN/SLING NO BOLTING
CLOSE HI-TRAC DOORS AND INSTALL DOOR LOCKING PINS	4	13B	2	692.0	46.1	92.3	2 PINS@2MIN/PIN
DISCONNECT SLINGS FROM MPC LIFT CLEATS	10	13A	2	363.8	60.6	121.3	2 SLINGS@5MIN/SLING
DOWNEND HI-TRAC ON TRANSPORT FRAME	20	12A	2	35.2	11.7	23.5	ALIGN TRUNNIONS, DISCONNECT LIFT YOKE
TRANSPORT HI-TRAC TO FUEL BUILDING	90	12A	1	35.2	52.8	52.8	DRIVER RECEIVES MOST DOSE
UPEND HI-TRAC	20	12A	2	35.2	11.7	23.5	ALIGN TRUNNIONS, DISCONNECT LIFT YOKE
Section 8.3.3							
MOVE HI-TRAC TO TRANSFER SLIDE	20	11A	2	900.9	300.3	600.6	ALIGN TRUNNIONS, DISCONNECT LIFT YOKE
ATTACH MPC SLINGS	4	9A	2	363.8	24.3	48.5	INSTALLED BY HAND NO TOOLS
REMOVE TRANSFER LID BOLTS	6	11B	1	2190.1	219.0	219.0	36 BOLTS@6 BOLTS/MIN IMPACT TOOLS USED
INSTALL POOL LID BOLTS	18	10A	1	2190.1	657.0	657.0	36 BOLTS @ 2/MIN IMPACT TOOLS USED 1 PASS
DISCONNECT MPC SLINGS AND LIFT CLEATS	10	9A	1	363.8	60.6	60.6	4 BOLTS,NO TORQUING
PLACE HI-TRAC IN PREPARATION AREA	15	9C	1	900.9	225.2	225.2	100 FT @ 10 FT/MIN (CRANE SPEED)+ 5MIN TO ALIGN
REMOVE TOP LID BOLTS	6	9B	1	79.5	8.0	8.0	24 BOLTS AT 4/MIN (NO TORQUE IMPACT TOOLS)
REMOVE HI-TRAC TOP LID	2	6A	1	34.2	1.1	1.1	4 SHACKLES@2/MIN
ATTACH WATER FILL LINE TO HI-TRAC DRAIN PORT	0.5	9D	1	2190.1	18.3	18.3	QUICK DISCONNECT NO TOOLS
INSTALL BOLT PLUGS OR WATERPROOF TAPE FROM HI-TRAC TOP BOLT HOLES	9	8A	1	79.5	11.9	11.9	18 HOLES@2/MIN
CORE DRILL CLOSURE RING AND VENT AND DRAIN PORT COVER PLATES	40	7A	2	34.2	22.8	45.6	20 MINUTES TO INSTALL/ALIGN +10 MIN/COVER

HOLTEC INTERNATIONAL COPYRIGHTED MATERIAL

Table 10.3.2b
HI-STORM 100 SYSTEM UNLOADING OPERATIONS USING THE 100-TON HI-TRAC TRANSFER CASK
ESTIMATED OPERATIONAL EXPOSURES[†] (60,000 MWD/MTU, 3-YEAR COOLED PWR FUEL)

ACTION	DURATION (MINUTES)	OPERATOR LOCATION (FIGURE 10.3.1)	NUMBER OF OPERATORS	DOSE RATE AT OPERATOR LOCATION (MREM/HR)	DOSE TO INDIVIDUAL (MREM)	TOTAL DOSE (PERSON-MREM)	ASSUMPTIONS
REMOVE CLOSURE RING SECTION AND VENT AND DRAIN PORT COVER PLATES	1	8A	1	79.5	1.3	1.3	2 COVERS@2/MIN NO TOOLS
ATTACH RVOAs	2	8A	1	79.5	2.7	2.7	SINGLE THREADED CONNECTION (1 RVOA)
ATTACH A SAMPLE BOTTLE TO VENT PORT RVOA	0.5	8A	1	79.5	0.7	0.7	1" THREADED FITTING NO TOOLS
GATHER A GAS SAMPLE FROM MPC	0.5	8A	1	79.5	0.7	0.7	SMALL BALL VALVE
CLOSE VENT PORT CAP AND DISCONNECT SAMPLE BOTTLE	1	8A	1	79.5	1.3	1.3	1" THREADED FITTING NO TOOLS
ATTACH RE-FLOOD SYSTEM TO RVOAs	2	8A	1	79.5	2.7	2.7	1" THREADED FITTING NO TOOLS X 2
DISCONNECT RE-FLOOD LINES TO VENT AND DRAIN PORT RVOAs	1	8A	1	79.5	1.3	1.3	1" THREADED FITTING NO TOOLS
VACUUM TOP SURFACES OF MPC AND HI-TRAC	10	6A	1	34.2	5.7	5.7	SHOP VACUUM WITH WAND + HAND WIPE
REMOVE ANNULUS SHIELD	1	8A	1	79.5	1.3	1.3	SHIELD PLACED BY HAND
MANUALLY INSTALL INFLATABLE SEAL	10	6A	2	34.2	5.7	11.4	CONSULTATION WITH CALVERT CLIFFS
OPEN NEUTRON SHIELD JACKET DRAIN VALVE	2	5C	1	282.1	9.4	9.4	SINGLE THREADED CONNECTION
CLOSE NEUTRON SHIELD JACKET DRAIN VALVE	2	5C	1	282.1	9.4	9.4	SINGLE THREADED CONNECTION
REMOVE MPC LID LIFTING HOLE PLUGS	2	5A	1	69.8	2.3	2.3	4 PLUGS AT 2/MIN NO TORQUING
ATTACH LID RETENTION SYSTEM	12	5A	1	69.8	14.0	14.0	24 BOLTS @ 2 MINUTES/BOLT
ATTACH ANNULUS OVERPRESSURE SYSTEM	0.5	5C	1	282.1	2.4	2.4	QUICK DISCONNECT NO TOOLS
POSITION HI-TRAC OVER CASK LOADING AREA	10	5C	1	282.1	47.0	47.0	100 FT @ 10 FT/MIN (CRANE SPEED)
LOWER HI-TRAC INTO SPENT FUEL POOL	8.5	3C	1	837.0	118.6	118.6	17 FEET @ 2 FT/MIN (CRANE SPEED)
REMOVE LID RETENTION BOLTS	12	3B	1	90.3	18.1	18.1	24 BOLTS @ 2/MINUTE
PLACE HI-TRAC ON FLOOR	20	2	2	3	1.0	2.0	40 FEET @ 2 FT/MINUTE (CRANE SPEED)

HOLTEC INTERNATIONAL COPYRIGHTED MATERIAL

Table 10.3.2b
HI-STORM 100 SYSTEM UNLOADING OPERATIONS USING THE 100-TON HI-TRAC TRANSFER CASK
ESTIMATED OPERATIONAL EXPOSURES[†] (60,000 MWD/MTU, 3-YEAR COOLED PWR FUEL)

ACTION	DURATION (MINUTES)	OPERATOR LOCATION (FIGURE 10.3.1)	NUMBER OF OPERATORS	DOSE RATE AT OPERATOR LOCATION (MREM/HR)	DOSE TO INDIVIDUAL (MREM)	TOTAL DOSE (PERSON-MREM)	ASSUMPTIONS
REMOVE MPC LID	20	2	2	3	1.0	2.0	CONSULTATION WITH CALVERT CLIFFS
Section 8.3.4							
REMOVE SPENT FUEL ASSEMBLIES FROM MPC	1020	1	2	3	51.0	102.0	15 MINUTES PER ASSEMBLY/68 ASSY
TOTAL						3275.0 PERSON-MREM	

HOLTEC INTERNATIONAL COPYRIGHTED MATERIAL

Table 10.3.2c
HI-STORM 100 SYSTEM UNLOADING OPERATIONS USING THE 125-TON HI-TRAC 125D TRANSFER CASK
ESTIMATED OPERATIONAL EXPOSURES[†] (75,000 MWD/MTU, 5-YEAR COOLED PWR FUEL)

ACTION	DURATION (MINUTES)	OPERATOR LOCATION (FIGURE 10.3.1)	NUMBER OF OPERATORS	DOSE RATE AT OPERATOR LOCATION (MREM/HR)	DOSE TO INDIVIDUAL (MREM)	TOTAL DOSE (PERSON-MREM)	ASSUMPTIONS
Section 8.3.2 (Step Sequence Varies By Site and Mode of Transport)							
REMOVE INLET VENT SCREENS	20	16D	1	122.7	40.9	40.9	4 SCREENS@5MIN/SCREEN
INSERT HI-STORM LIFTING JACKS	4	16D	1	122.7	8.2	8.2	4 JACKS@1/MIN
INSERT AIR PAD	5	16D	2	122.7	10.2	20.5	1 PAD MOVED BY HAND
REMOVE HI-STORM LIFTING JACKS	4	16D	1	122.7	8.2	8.2	4 JACKS@1/MIN
TRANSFER HI-STORM TO MPC TRANSFER LOCATION	40	16C	1	69.7	46.5	46.5	200 FEET @ 4FT/MIN
REMOVE HI-STORM LID STUDS/NUTS	10	16A	1	11.7	2.0	2.0	4 BOLTS NO TORQUE
REMOVE HI-STORM LID LIFTING HOLE PLUGS AND INSTALL LID LIFTING SLING	2	16A	1	11.7	0.4	0.4	4 PLUGS AT 2/MIN NO TORQUING
REMOVE GAMMA SHIELD CROSS PLATES	4	16B	1	205.5	13.7	13.7	4 PLATES@1/MIN
REMOVE TEMPERATURE ELEMENTS	8	16B	1	205.5	27.4	27.4	4 TEMP. ELEMENTS @ 2MIN/TEMP. ELEMENT NO TORQUE
REMOVE HI-STORM LID	2	16A	1	11.7	0.4	0.4	4 SHACKLES@2/MIN
INSTALL HI-STORM VENT DUCT SHIELD INSERTS	2	15A	1	43.9	1.5	1.5	4 SHACKLES@2/MIN
INSTALL MATING DEVICE WITH POOL LID	10	15A	1	43.9	7.3	7.3	3 BOLTS AT 2 MINUTES PER BOLT
REMOVE MPC LIFT CLEAT HOLE PLUGS	2	14A	1	487.4	16.2	16.2	4 PLUGS AT 2/MIN NO TORQUING
INSTALL MPC LIFT CLEATS AND MPC SLINGS	2	14A	1	487.4	16.2	16.2	4 PLUGS AT 2/MIN NO TORQUING
ALIGN HI-TRAC OVER HI-STORM AND MATE OVERPACKS	10	13B	2	118.5	19.8	39.5	ALIGNMENT GUIDES USED

[†] See notes at bottom of Table 10.3.4.

HOLTEC INTERNATIONAL COPYRIGHTED MATERIAL

Table 10.3.2c
HI-STORM 100 SYSTEM UNLOADING OPERATIONS USING THE 125-TON HI-TRAC 125D TRANSFER CASK
ESTIMATED OPERATIONAL EXPOSURES[†] (75,000 MWD/MTU, 5-YEAR COOLED PWR FUEL)

ACTION	DURATION (MINUTES)	OPERATOR LOCATION (FIGURE 10.3.1)	NUMBER OF OPERATORS	DOSE RATE AT OPERATOR LOCATION (MREM/HR)	DOSE TO INDIVIDUAL (MREM)	TOTAL DOSE (PERSON-MREM)	ASSUMPTIONS
PULL MPC SLINGS THROUGH TOP LID HOLE	10	13A	2	158.5	26.4	52.8	2 SLINGS@5MIN/SLING
INSTALL TRIM PLATES	4	13B	2	118.5	7.9	15.8	INSTALLED BY HAND NO FASTENERS
ATTACH MPC SLING TO LIFTING DEVICE	10	13A	1	158.5	26.4	26.4	2 SLINGS@5MIN/SLING NO BOLTING
CLOSE MATING DEVICE DRAWER AND BOLT-UP POOL LID	36	13B	2	118.5	71.1	142.2	2 PINS@2MIN/PIN, 16 BOLTS @ 2MIN/BOLT
DISCONNECT SLINGS FROM MPC LIFT CLEATS	10	13A	2	158.5	26.4	52.8	2 SLINGS@5MIN/SLING
DOWNEND HI-TRAC ON TRANSPORT FRAME	20	12A	2	26.4	8.8	17.6	ALIGN TRUNNIONS, DISCONNECT LIFT YOKE
TRANSPORT HI-TRAC TO FUEL BUILDING	90	12A	1	26.4	39.6	39.6	DRIVER RECEIVES MOST DOSE
UPEND HI-TRAC	20	12A	2	26.4	8.8	17.6	ALIGN TRUNNIONS, DISCONNECT LIFT YOKE
Section 8.3.3							
PLACE HI-TRAC IN PREPARATION AREA	15	.9C	1	117.8	29.5	29.5	100 FT @ 10 FT/MIN (CRANE SPEED)+ 5MIN TO ALIGN
REMOVE TOP LID BOLTS	6	9B	1	37.9	3.8	3.8	24 BOLTS AT 4/MIN (NO TORQUE IMPACT TOOLS)
REMOVE HI-TRAC TOP LID	2	6A	1	18.7	0.6	0.6	4 SHACKLES@2/MIN
ATTACH WATER FILL LINE TO HI-TRAC DRAIN PORT	0.5	9D	1	354.2	3.0	3.0	QUICK DISCONNECT NO TOOLS
INSTALL BOLT PLUGS OR WATERPROOF TAPE FROM HI-TRAC TOP BOLT HOLES	9	8A	1	37.9	5.7	5.7	18 HOLES@2/MIN
CORE DRILL CLOSURE RING AND VENT AND DRAIN PORT COVER PLATES	40	7A	2	18.7	12.5	24.9	20 MINUTES TO INSTALL/ALIGN +10 MIN/COVER
REMOVE CLOSURE RING SECTION AND VENT AND DRAIN PORT COVER PLATES	1	8A	1	37.9	0.6	0.6	2 COVERS@2/MIN NO TOOLS
ATTACH RVOAS	2	8A	1	37.9	1.3	1.3	SINGLE THREADED CONNECTION (1 RVOA)

HOLTEC INTERNATIONAL COPYRIGHTED MATERIAL

Table 10.3.2c
HI-STORM 100 SYSTEM UNLOADING OPERATIONS USING THE 125-TON HI-TRAC 125D TRANSFER CASK
ESTIMATED OPERATIONAL EXPOSURES[†] (75,000 MWD/MTU, 5-YEAR COOLED PWR FUEL)

ACTION	DURATION (MINUTES)	OPERATOR LOCATION (FIGURE 10.3.1)	NUMBER OF OPERATORS	DOSE RATE AT OPERATOR LOCATION (MREM/HR)	DOSE TO INDIVIDUAL (MREM)	TOTAL DOSE (PERSON-MREM)	ASSUMPTIONS
ATTACH A SAMPLE BOTTLE TO VENT PORT RVOA	0.5	8A	1	37.9	0.3	0.3	1" THREADED FITTING NO TOOLS
GATHER A GAS SAMPLE FROM MPC	0.5	8A	1	37.9	0.3	0.3	SMALL BALL VALVE
CLOSE VENT PORT CAP AND DISCONNECT SAMPLE BOTTLE	1	8A	1	37.9	0.6	0.6	1" THREADED FITTING NO TOOLS
ATTACH RE-FLOOD SYSTEM TO RVOAs	2	8A	1	37.9	1.3	1.3	1" THREADED FITTING NO TOOLS X 2
DISCONNECT RE-FLOOD LINES TO VENT AND DRAIN PORT RVOAs	1	8A	1	37.9	0.6	0.6	1" THREADED FITTING NO TOOLS
VACUUM TOP SURFACES OF MPC AND HI-TRAC	10	6A	1	18.7	3.1	3.1	SHOP VACUUM WITH WAND + HAND WIPE
REMOVE ANNULUS SHIELD	1	8A	1	37.9	0.6	0.6	SHIELD PLACED BY HAND
MANUALLY INSTALL INFLATABLE SEAL	10	6A	2	18.7	3.1	6.2	CONSULTATION WITH CALVERT CLIFFS
OPEN NEUTRON SHIELD JACKET DRAIN VALVE	2	5C	1	82.7	2.8	2.8	SINGLE THREADED CONNECTION
CLOSE NEUTRON SHIELD JACKET DRAIN VALVE	2	5C	1	82.7	2.8	2.8	SINGLE THREADED CONNECTION
REMOVE MPC LID LIFTING HOLE PLUGS	2	5A	1	37.3	1.2	1.2	4 PLUGS AT 2/MIN NO TORQUING
ATTACH LID RETENTION SYSTEM	12	5A	1	37.3	7.5	7.5	24 BOLTS @ 2 MINUTES/BOLT
ATTACH ANNULUS OVERPRESSURE SYSTEM	0.5	5C	1	82.7	0.7	0.7	QUICK DISCONNECT NO TOOLS
POSITION HI-TRAC OVER CASK LOADING AREA	10	5C	1	82.7	13.8	13.8	100 FT @ 10 FT/MIN (CRANE SPEED)
LOWER HI-TRAC INTO SPENT FUEL POOL	8.5	3C	1	117.8	16.7	16.7	17 FEET @ 2 FT/MIN (CRANE SPEED)
REMOVE LID RETENTION BOLTS	12	3B	1	46.4	9.3	9.3	24 BOLTS @ 2/MINUTE
PLACE HI-TRAC ON FLOOR	20	2	2	2.0	0.7	1.3	40 FEET @ 2 FT/MINUTE (CRANE SPEED)
REMOVE MPC LID	20	2	2	2.0	0.7	1.3	CONSULTATION WITH CALVERT CLIFFS

HOLTEC INTERNATIONAL COPYRIGHTED MATERIAL

Table 10.3.2c							
HI-STORM 100 SYSTEM UNLOADING OPERATIONS USING THE 125-TON HI-TRAC 125D TRANSFER CASK ESTIMATED OPERATIONAL EXPOSURES[†] (75,000 MWD/MTU, 5-YEAR COOLED PWR FUEL)							
ACTION	DURATION (MINUTES)	OPERATOR LOCATION (FIGURE 10.3.1)	NUMBER OF OPERATORS	DOSE RATE AT OPERATOR LOCATION (MREM/HR)	DOSE TO INDIVIDUAL (MREM)	TOTAL DOSE (PERSON- MREM)	ASSUMPTIONS
Section 8.3.4							
REMOVE SPENT FUEL ASSEMBLIES FROM MPC	1020	1	2	1.0	17.0	34.0	15 MINUTES PER ASSEMBLY/68 ASSY
TOTAL							787.5 PERSON-MREM

HOLTEC INTERNATIONAL COPYRIGHTED MATERIAL

Table 10.3.3a
MPC TRANSFER INTO THE HI-STORM 100 SYSTEM DIRECTLY FROM TRANSPORT USING
THE 125-TON HI-TRAC TRANSFER CASK
ESTIMATED OPERATIONAL EXPOSURES[†] (75,000 MWD/MTU, 5-YEAR COOLED PWR FUEL)

ACTION	DURATION (MINUTES)	OPERATOR LOCATION (FIGURE 10.3.1)	NUMBER OF OPERATORS	DOSE RATE AT OPERATOR LOCATION (MREM/HR)	DOSE TO INDIVIDUAL (MREM)	TOTAL DOSE (PERSON-MREM)	ASSUMPTIONS
Section 8.5.2							
MEASURE HI-STAR DOSE RATES	16	17A	2	14.1	3.8	7.5	16 POINTS@1 POINT/MIN
REMOVE PERSONNEL BARRIER	10	17C	2	21.5	3.6	7.2	ATTACH SLING REMOVE 8 LOCKS
PERFORM REMOVABLE CONTAMINATION SURVEYS	1	17C	1	21.5	0.4	0.4	10 SMEARS@10 SMEARS/MINUTE
REMOVE IMPACT LIMITERS	16	17A	2	14.1	3.8	7.5	ATTACH FRAME REMOVE 22 BOLTS IMPACT TOOLS
REMOVE TIE-DOWN	6	17A	2	14.1	1.4	2.8	ATTACH 2-LEGGED SLING REMOVE 4 BOLTS
PERFORM A VISUAL INSPECTION OF OVERPACK	10	17B	1	9.0	1.5	1.5	CHECKSHEET USED
REMOVE REMOVABLE SHEAR RING SEGMENTS	4	17A	1	14.1	0.9	0.9	4 BOLTS EACH @2/MIN X 2 SEGMENTS
UPEND HI-STAR OVERPACK	20	17B	2	9.0	3.0	6.0	DISCONNECT LIFT YOKE
INSTALL TEMPORARY SHIELD RING SEGMENTS	16	18A	1	7.1	1.9	1.9	8 SEGMENTS @ 2 MIN/SEGMENT
FILL TEMPORARY SHIELD RING SEGMENTS	25	18A	1	7.1	3.0	3.0	230 GAL @10GPM, LONG HANDLED SPRAYER
REMOVE OVERPACK VENT PORT COVER PLATE	2	18A	1	7.1	0.2	0.2	4 BOLTS @2/MIN
ATTACH BACKFILL TOOL	2	18A	1	7.1	0.2	0.2	4 BOLTS @2/MIN
OPEN/CLOSE VENT PORT PLUG	0.5	18A	1	7.1	0.1	0.1	SINGLE TURN BY HAND NO TOOLS
REMOVE CLOSURE PLATE BOLTS	39	18A	2	7.1	4.6	9.2	52 BOLTS@4/MIN X 3 PASSES
REMOVE OVERPACK CLOSURE PLATE	2	18A	1	7.1	0.2	0.2	4 SHACKLES@2/MIN
INSTALL HI-STAR SEAL SURFACE PROTECTOR	2	19B	1	7.1	0.2	0.2	PLACED BY HAND NO TOOLS
INSTALL TRANSFER COLLAR ON HI-STAR	10	19B	2	7.1	1.2	2.4	ALIGN AND POSITION REMOVE 4 SHACKLES
REMOVE MPC LIFT CLEAT HOLE PLUGS	2	19A	1	487.4	16.2	16.2	4 PLUGS AT 2/MIN NO TORQUING

[†] See notes at bottom of Table 10.3.4.

Table 10.3.3a
MPC TRANSFER INTO THE HI-STORM 100 SYSTEM DIRECTLY FROM TRANSPORT USING
THE 125-TON HI-TRAC TRANSFER CASK
ESTIMATED OPERATIONAL EXPOSURES[†] (75,000 MWD/MTU, 5-YEAR COOLED PWR FUEL)

ACTION	DURATION (MINUTES)	OPERATOR LOCATION (FIGURE 10.3.1)	NUMBER OF OPERATORS	DOSE RATE AT OPERATOR LOCATION (MREM/HR)	DOSE TO INDIVIDUAL (MREM)	TOTAL DOSE (PERSON-MREM)	ASSUMPTIONS
INSTALL MPC LIFT CLEATS AND LIFT SLING	25	19A	2	487.4	203.1	406.2	INSTALL CLEATS AND HYDRO TORQUE 4 BOLTS
MATE OVERPACKS	10	20B	2	118.5	19.8	39.5	ALIGNMENT GUIDES USED
REMOVE DOOR LOCKING PINS AND OPEN DOORS	4	20B	2	118.5	7.9	15.8	2 PINS@2/MIN
INSTALL TRIM PLATES	4	20B	2	118.5	7.9	15.8	INSTALLED BY HAND NO FASTENERS
Section 8.5.3							
REMOVE TRIM PLATES	4	20B	2	118.5	7.9	15.8	INSTALLED BY HAND NO FASTENERS
DISCONNECT SLINGS FROM MPC LIFTING DEVICE	10	20A	2	158.5	26.4	52.8	2 SLINGS@5/MIN
INSTALL TRIM PLATES	4	13B	2	118.5	7.9	15.8	INSTALLED BY HAND NO FASTENERS
REMOVE MPC LIFT CLEATS AND MPC LIFT SLINGS	10	14A	1	487.4	81.2	81.2	4 BOLTS,NO TORQUING
INSTALL HOLE PLUGS IN EMPTY MPC BOLT HOLES	2	14A	1	487.4	16.2	16.2	4 PLUGS AT 2/MIN NO TORQUING
REMOVE HI-STORM VENT DUCT SHIELD INSERTS	2	15A	1	43.9	1.5	1.5	4 SHACKLES@2/MIN
REMOVE ALIGNMENT DEVICE	4	15A	1	43.9	2.9	2.9	REMOVED BY HAND NO TOOLS (4 PCS@1/MIN)
INSTALL HI-STORM LID AND INSTALL LID STUDS/NUTS	25	16A	2	11.7	4.9	9.8	INSTALL LID AND HYDRO TORQUE 4 BOLTS
INSTALL HI-STORM EXIT VENT GAMMA SHIELD CROSS PLATES	4	16B	1	205.5	13.7	13.7	4 PCS @ 1/MIN INSTALL BY HAND NO TOOLS
INSTALL TEMPERATURE ELEMENTS	20	16B	1	205.5	68.5	68.5	4@5MIN/TEMPERATURE ELEMENT
INSTALL EXIT VENT SCREENS	20	16B	1	205.5	68.5	68.5	4 SCREENS@5MIN/SCREEN
REMOVE HI-STORM LID LIFTING DEVICE	2	16A	1	11.7	0.4	0.4	4 SHACKLES@2/MIN
INSTALL HOLE PLUGS IN EMPTY HOLES	2	16A	1	11.7	0.4	0.4	4 PLUGS AT 2/MIN NO TORQUING
PERFORM SHIELDING EFFECTIVENESS TESTING	16	16D	1	122.7	32.7	32.7	16POINTS@1 MIN

HOLTEC INTERNATIONAL COPYRIGHTED MATERIAL

Table 10.3.3a
MPC TRANSFER INTO THE HI-STORM 100 SYSTEM DIRECTLY FROM TRANSPORT USING
THE 125-TON HI-TRAC TRANSFER CASK
ESTIMATED OPERATIONAL EXPOSURES[†] (75,000 MWD/MTU, 5-YEAR COOLED PWR FUEL)

ACTION	DURATION (MINUTES)	OPERATOR LOCATION (FIGURE 10.3.1)	NUMBER OF OPERATORS	DOSE RATE AT OPERATOR LOCATION (MREM/HR)	DOSE TO INDIVIDUAL (MREM)	TOTAL DOSE (PERSON- MREM)	ASSUMPTIONS
SECURE HI-STORM TO TRANSPORT DEVICE	10	16A	1	11.7	2.0	2.0	ASSUMES AIR PAD
TRANSFER HI-STORM TO ITS DESIGNATED STORAGE LOCATION	40	16C	1	69.7	46.5	46.5	200 FEET @ 4FT/MIN
INSERT HI-STORM LIFTING JACKS	4	16D	1	122.7	8.2	8.2	4 JACKS@1/MIN
REMOVE AIR PAD	5	16D	1	122.7	10.2	10.2	1 PAD MOVED BY HAND
REMOVE HI-STORM LIFTING JACKS	4	16D	1	122.7	8.2	8.2	4 JACKS@1/MIN
INSTALL INLET VENT SCREENS	20	16D	1	122.7	40.9	40.9	4 SCREENS@5MIN/SCREEN
PERFORM AIR TEMPERATURE RISE TEST	8	16B	1	205.5	27.4	27.4	8 MEASMT@1/MIN
TOTAL						1068.3 PERSON-MREM	

HOLTEC INTERNATIONAL COPYRIGHTED MATERIAL

Table 10.3.3b
MPC TRANSFER INTO THE HI-STORM 100 SYSTEM DIRECTLY FROM TRANSPORT USING
THE 100-TON HI-TRAC TRANSFER CASK
ESTIMATED OPERATIONAL EXPOSURES[†] (60,000 MWD/MTU, 3-YEAR COOLED PWR FUEL)

ACTION	DURATION (MINUTES)	OPERATOR LOCATION (FIGURE 10.3.1)	NUMBER OF OPERATORS	DOSE RATE AT OPERATOR LOCATION (MREM/HR)	DOSE TO INDIVIDUAL (MREM)	TOTAL DOSE (PERSON-MREM)	ASSUMPTIONS
Section 8.5.2							
MEASURE HI-STAR DOSE RATES	16	17A	2	14.1	3.8	7.5	16 POINTS@1 POINT/MIN
REMOVE PERSONNEL BARRIER	10	17C	2	21.5	3.6	7.2	ATTACH SLING REMOVE 8 LOCKS
PERFORM REMOVABLE CONTAMINATION SURVEYS	1	17C	1	21.5	0.4	0.4	10 SMEARS@10 SMEARS/MINUTE
REMOVE IMPACT LIMITERS	16	17A	2	14.1	3.8	7.5	ATTACH FRAME REMOVE 22 BOLTS IMPACT TOOLS
REMOVE TIE-DOWN	6	17A	2	14.1	1.4	2.8	ATTACH 2-LEGGED SLING REMOVE 4 BOLTS
PERFORM A VISUAL INSPECTION OF OVERPACK	10	17B	1	9.0	1.5	1.5	CHECKSHEET USED
REMOVE REMOVABLE SHEAR RING SEGMENTS	4	17A	1	14.1	0.9	0.9	4 BOLTS EACH @2/MIN X 2 SEGMENTS
UPEND HI-STAR OVERPACK	20	17B	2	9.0	3.0	6.0	DISCONNECT LIFT YOKE
INSTALL TEMPORARY SHIELD RING SEGMENTS	16	18A	1	6.9	1.8	1.8	8 SEGMENTS @ 2 MIN/SEGMENT
FILL TEMPORARY SHIELD RING SEGMENTS	25	18A	1	6.9	2.9	2.9	230 GAL @10GPM, LONG HANDLED SPRAYER
REMOVE OVERPACK VENT PORT COVER PLATE	2	18A	1	6.9	0.2	0.2	4 BOLTS @2/MIN
ATTACH BACKFILL TOOL	2	18A	1	6.9	0.2	0.2	4 BOLTS @2/MIN
OPEN/CLOSE VENT PORT PLUG	0.5	18A	1	6.9	0.1	0.1	SINGLE TURN BY HAND NO TOOLS
REMOVE CLOSURE PLATE BOLTS	39	18A	2	6.9	4.5	9.0	52 BOLTS@4/MIN X 3 PASSES
REMOVE OVERPACK CLOSURE PLATE	2	18A	1	6.9	0.2	0.2	4 SHACKLES@2/MIN
INSTALL HI-STAR SEAL SURFACE PROTECTOR	2	19B	1	6.9	0.2	0.2	PLACED BY HAND NO TOOLS
INSTALL TRANSFER COLLAR ON HI-STAR	10	19B	2	6.9	1.2	2.3	ALIGN AND POSITION REMOVE 4 SHACKLES
REMOVE MPC LIFT CLEAT HOLE PLUGS	2	19A	1	487.4	16.2	16.2	4 PLUGS AT 2/MIN NO TORQUING

[†] See notes at bottom of Table 10.3.4.

HOLTEC INTERNATIONAL COPYRIGHTED MATERIAL

Table 10.3.3b
MPC TRANSFER INTO THE HI-STORM 100 SYSTEM DIRECTLY FROM TRANSPORT USING
THE 100-TON HI-TRAC TRANSFER CASK
ESTIMATED OPERATIONAL EXPOSURES[†] (60,000 MWD/MTU, 3-YEAR COOLED PWR FUEL)

ACTION	DURATION (MINUTES)	OPERATOR LOCATION (FIGURE 10.3.1)	NUMBER OF OPERATORS	DOSE RATE AT OPERATOR LOCATION (MREM/HR)	DOSE TO INDIVIDUAL (MREM)	TOTAL DOSE (PERSON-MREM)	ASSUMPTIONS
INSTALL MPC LIFT CLEATS AND LIFT SLING	25	19A	2	487.4	203.1	406.2	INSTALL CLEATS AND HYDRO TORQUE 4 BOLTS
MATE OVERPACKS	10	20B	2	692.0	115.3	230.7	ALIGNMENT GUIDES USED
REMOVE DOOR LOCKING PINS AND OPEN DOORS	4	20B	2	692.0	46.1	92.3	2 PINS@2/MIN
INSTALL TRIM PLATES	4	20B	2	692.0	46.1	92.3	INSTALLED BY HAND NO FASTENERS
Section 8.5.3							
REMOVE TRIM PLATES	4	20B	2	692.0	46.1	92.3	INSTALLED BY HAND NO FASTENERS
DISCONNECT SLINGS FROM MPC LIFTING DEVICE	10	20A	2	363.8	60.6	121.3	2 SLINGS@5/MIN
REMOVE TRIM PLATES	4	13B	2	692.0	46.1	92.3	INSTALLED BY HAND NO FASTENERS
REMOVE MPC LIFT CLEATS AND MPC LIFT SLINGS	10	14A	1	487.4	81.2	81.2	4 BOLTS,NO TORQUING
INSTALL HOLE PLUGS IN EMPTY MPC BOLT HOLES	2	14A	1	487.4	16.2	16.2	4 PLUGS AT 2/MIN NO TORQUING
REMOVE HI-STORM VENT DUCT SHIELD INSERTS	2	15A	1	43.9	1.5	1.5	4 SHACKLES@2/MIN
REMOVE ALIGNMENT DEVICE	4	15A	1	43.9	2.9	2.9	REMOVED BY HAND NO TOOLS (4 PCS@1/MIN)
INSTALL HI-STORM LID AND INSTALL LID STUDS/NUTS	25	16A	2	11.7	4.9	9.8	INSTALL LID AND HYDRO TORQUE 4 BOLTS
INSTALL HI-STORM EXIT VENT GAMMA SHIELD CROSS PLATES	4	16B	1	205.5	13.7	13.7	4 PCS @ 1/MIN INSTALL BY HAND NO TOOLS
INSTALL TEMPERATURE ELEMENTS	20	16B	1	205.5	68.5	68.5	4@5MIN/TEMPERATURE ELEMENT
INSTALL EXIT VENT SCREENS	20	16B	1	205.5	68.5	68.5	4 SCREENS@5MIN/SCREEN
REMOVE HI-STORM LID LIFTING DEVICE	2	16A	1	11.7	0.4	0.4	4 SHACKLES@2/MIN
INSTALL HOLE PLUGS IN EMPTY HOLES	2	16A	1	11.7	0.4	0.4	4 PLUGS AT 2/MIN NO TORQUING
PERFORM SHIELDING EFFECTIVENESS TESTING	16	16D	1	122.7	32.7	32.7	16POINTS@1 MIN

HOLTEC INTERNATIONAL COPYRIGHTED MATERIAL

Table 10.3.3b
MPC TRANSFER INTO THE HI-STORM 100 SYSTEM DIRECTLY FROM TRANSPORT USING
THE 100-TON HI-TRAC TRANSFER CASK
ESTIMATED OPERATIONAL EXPOSURES[†] (60,000 MWD/MTU, 3-YEAR COOLED PWR FUEL)

ACTION	DURATION (MINUTES)	OPERATOR LOCATION (FIGURE 10.3.1)	NUMBER OF OPERATORS	DOSE RATE AT OPERATOR LOCATION (MREM/HR)	DOSE TO INDIVIDUAL (MREM)	TOTAL DOSE (PERSON-MREM)	ASSUMPTIONS
SECURE HI-STORM TO TRANSPORT DEVICE	10	16A	1	11.7	2.0	2.0	ASSUMES AIR PAD
TRANSFER HI-STORM TO ITS DESIGNATED STORAGE LOCATION	40	16C	1	69.7	46.5	46.5	200 FEET @ 4FT/MIN
INSERT HI-STORM LIFTING JACKS	4	16D	1	122.7	8.2	8.2	4 JACKS@1/MIN
REMOVE AIR PAD	5	16D	1	122.7	10.2	10.2	1 PAD MOVED BY HAND
REMOVE HI-STORM LIFTING JACKS	4	16D	1	122.7	8.2	8.2	4 JACKS@1/MIN
INSTALL INLET VENT SCREENS	20	16D	1	122.7	40.9	40.9	4 SCREENS@5MIN/SCREEN
PERFORM AIR TEMPERATURE RISE TEST	8	16B	1	205.5	27.4	27.4	8 MEASMT@1/MIN
TOTAL						1633.3 PERSON-MREM	

HOLTEC INTERNATIONAL COPYRIGHTED MATERIAL

HI-STORM FSAR
 REPORT HI-2002444

10.3-39

Rev. 7

HI-STORM 100 FSAR, NON-PROPRIETARY
 REVISION 12
 MARCH 12, 2014

Table 10.3.3c
MPC TRANSFER INTO THE HI-STORM 100 SYSTEM DIRECTLY FROM TRANSPORT USING
THE 125-TON HI-TRAC 125D TRANSFER CASK
ESTIMATED OPERATIONAL EXPOSURES[†] (75,000 MWD/MTU, 5-YEAR COOLED PWR FUEL)

ACTION	DURATION (MINUTES)	OPERATOR LOCATION (FIGURE 10.3.1)	NUMBER OF OPERATORS	DOSE RATE AT OPERATOR LOCATION (MREM/HR)	DOSE TO INDIVIDUAL (MREM)	TOTAL DOSE (PERSON-MREM)	ASSUMPTIONS
Section 8.5.2							
MEASURE HI-STAR DOSE RATES	16	17A	2	14.1	3.8	7.5	16 POINTS@1 POINT/MIN
REMOVE PERSONNEL BARRIER	10	17C	2	21.5	3.6	7.2	ATTACH SLING REMOVE 8 LOCKS
PERFORM REMOVABLE CONTAMINATION SURVEYS	1	17C	1	21.5	0.4	0.4	10 SMEARS@10 SMEARS/MINUTE
REMOVE IMPACT LIMITERS	16	17A	2	14.1	3.8	7.5	ATTACH FRAME REMOVE 22 BOLTS IMPACT TOOLS
REMOVE TIE-DOWN	6	17A	2	14.1	1.4	2.8	ATTACH 2-LEGGED SLING REMOVE 4 BOLTS
PERFORM A VISUAL INSPECTION OF OVERPACK	10	17B	1	9.0	1.5	1.5	CHECKSHEET USED
REMOVE REMOVABLE SHEAR RING SEGMENTS	4	17A	1	14.1	0.9	0.9	4 BOLTS EACH @2/MIN X 2 SEGMENTS
UPEND HI-STAR OVERPACK	20	17B	2	9.0	3.0	6.0	DISCONNECT LIFT YOKE
INSTALL TEMPORARY SHIELD RING SEGMENTS	16	18A	1	7.1	1.9	1.9	8 SEGMENTS @ 2 MIN/SEGMENT
FILL TEMPORARY SHIELD RING SEGMENTS	25	18A	1	7.1	3.0	3.0	230 GAL @10GPM, LONG HANDLED SPRAYER
REMOVE OVERPACK VENT PORT COVER PLATE	2	18A	1	7.1	0.2	0.2	4 BOLTS @2/MIN
ATTACH BACKFILL TOOL	2	18A	1	7.1	0.2	0.2	4 BOLTS @2/MIN
OPEN/CLOSE VENT PORT PLUG	0.5	18A	1	7.1	0.1	0.1	SINGLE TURN BY HAND NO TOOLS
REMOVE CLOSURE PLATE BOLTS	39	18A	2	7.1	4.6	9.2	52 BOLTS@4/MIN X 3 PASSES
REMOVE OVERPACK CLOSURE PLATE	2	18A	1	6.7	0.2	0.2	4 SHACKLES@2/MIN

[†] See notes at bottom of Table 10.3.4.

HOLTEC INTERNATIONAL COPYRIGHTED MATERIAL

Table 10.3.3c
MPC TRANSFER INTO THE HI-STORM 100 SYSTEM DIRECTLY FROM TRANSPORT USING
THE 125-TON HI-TRAC 125D TRANSFER CASK
ESTIMATED OPERATIONAL EXPOSURES[†] (75,000 MWD/MTU, 5-YEAR COOLED PWR FUEL)

ACTION	DURATION (MINUTES)	OPERATOR LOCATION (FIGURE 10.3.1)	NUMBER OF OPERATORS	DOSE RATE AT OPERATOR LOCATION (MREM/HR)	DOSE TO INDIVIDUAL (MREM)	TOTAL DOSE (PERSON-MREM)	ASSUMPTIONS
INSTALL HI-STAR SEAL SURFACE PROTECTOR	2	19B	1	7.1	0.2	0.2	PLACED BY HAND NO TOOLS
INSTALL MATING DEVICE ON HI-STAR	20	19B	2	7.1	2.4	4.7	ALIGN AND BOLT INTO PLACE
REMOVE MPC LIFT CLEAT HOLE PLUGS	2	19A	1	487.4	16.2	16.2	4 PLUGS AT 2/MIN NO TORQUING
INSTALL MPC LIFT CLEATS AND LIFT SLING	25	19A	2	487.4	203.1	406.2	INSTALL CLEATS AND HYDRO TORQUE 4 BOLTS
MATE OVERPACKS	10	20B	2	118.5	19.8	39.5	ALIGNMENT GUIDES USED
REMOVE LOCKING PINS AND OPEN DRAWER	4	20B	2	118.5	7.9	15.8	2 PINS@2/MIN
INSTALL TRIM PLATES	4	20B	2	118.5	7.9	15.8	INSTALLED BY HAND NO FASTENERS
Section 8.5.3							
REMOVE TRIM PLATES	4	20B	2	118.5	7.9	15.8	INSTALLED BY HAND NO FASTENERS
RAISE THE POOL LID AND BOLT INTO PLACE ON HI-TRAC	32	20B	2	118.5	63.2	126.4	2 MINS/BOLT, 16 BOLTS
DISCONNECT SLINGS FROM MPC LIFTING DEVICE	10	20A	2	158.5	26.4	52.8	2 SLINGS@5/MIN
INSTALL TRIM PLATES	4	13B	2	118.5	7.9	15.8	INSTALLED BY HAND NO FASTENERS
REMOVE MPC LIFT CLEATS AND MPC LIFT SLINGS	10	14A	1	487.4	81.2	81.2	4 BOLTS,NO TORQUING
INSTALL HOLE PLUGS IN EMPTY MPC BOLT HOLES	2	14A	1	487.4	16.2	16.2	4 PLUGS AT 2/MIN NO TORQUING
REMOVE HI-STORM VENT DUCT SHIELD INSERTS	2	15A	1	43.9	1.5	1.5	4 SHACKLES@2/MIN
REMOVE THE MATING DEVICE	6	15A	1	43.9	4.4	4.4	3 BOLTS AT 2 MINUTES PER BOLTS
INSTALL HI-STORM LID AND INSTALL LID STUDS/NUTS	25	16A	2	11.7	4.9	9.8	INSTALL LID AND HYDRO TORQUE 4 BOLTS

HOLTEC INTERNATIONAL COPYRIGHTED MATERIAL

Table 10.3.3c
MPC TRANSFER INTO THE HI-STORM 100 SYSTEM DIRECTLY FROM TRANSPORT USING
THE 125-TON HI-TRAC 125D TRANSFER CASK
ESTIMATED OPERATIONAL EXPOSURES[†] (75,000 MWD/MTU, 5-YEAR COOLED PWR FUEL)

ACTION	DURATION (MINUTES)	OPERATOR LOCATION (FIGURE 10.3.1)	NUMBER OF OPERATORS	DOSE RATE AT OPERATOR LOCATION (MREM/HR)	DOSE TO INDIVIDUAL (MREM)	TOTAL DOSE (PERSON-MREM)	ASSUMPTIONS
INSTALL HI-STORM EXIT VENT GAMMA SHIELD CROSS PLATES	4	16B	1	205.5	13.7	13.7	4 PCS @ 1/MIN INSTALL BY HAND NO TOOLS
INSTALL TEMPERATURE ELEMENTS	20	16B	1	205.5	68.5	68.5	4@5MIN/TEMPERATURE ELEMENT
INSTALL EXIT VENT SCREENS	20	16B	1	205.5	68.5	68.5	4 SCREENS@5MIN/SCREEN
REMOVE HI-STORM LID LIFTING DEVICE	2	16A	1	11.7	0.4	0.4	4 SHACKLES@2/MIN
INSTALL HOLE PLUGS IN EMPTY HOLES	2	16A	1	11.7	0.4	0.4	4 PLUGS AT 2/MIN NO TORQUING
PERFORM SHIELDING EFFECTIVENESS TESTING	16	16D	1	122.7	32.7	32.7	16POINTS@1 MIN
SECURE HI-STORM TO TRANSPORT DEVICE	10	16A	1	11.7	2.0	2.0	ASSUMES AIR PAD
TRANSFER HI-STORM TO ITS DESIGNATED STORAGE LOCATION	40	16C	1	69.7	46.5	46.5	200 FEET @ 4FT/MIN
INSERT HI-STORM LIFTING JACKS	4	16D	1	122.7	8.2	8.2	4 JACKS @1/MIN
REMOVE AIR PAD	5	16D	1	122.7	10.2	10.2	1 PAD MOVED BY HAND
REMOVE HI-STORM LIFTING JACKS	4	16D	1	122.7	8.2	8.2	4 JACKS @1/MIN
INSTALL INLET VENT SCREENS	20	16D	1	122.7	40.9	40.9	4 SCREENS@5MIN/SCREEN
PERFORM AIR TEMPERATURE RISE TEST	8	16B	1	205.5	27.4	27.4	8 MEASMT@1/MIN
TOTAL							1198.6 PERSON-MREM

HOLTEC INTERNATIONAL COPYRIGHTED MATERIAL

Table 10.3.4
ESTIMATED EXPOSURES FOR HI-STORM 100 SURVEILLANCE AND MAINTENANCE

ACTIVITY	ESTIMATED PERSONNEL	ESTIMATED HOURS PER YEAR	ESTIMATED DOSE RATE (MREM/HR)	OCCUPATIONAL DOSE TO INDIVIDUAL (PERSON-MREM)
SECURITY SURVEILLANCE	1	30	3	90
ANNUAL MAINTENANCE	2	15	10	300

Notes for Tables 10.3.1a, 10.3.1b, 10.3.1c, 10.3.2a, 10.3.2b, 10.3.2c, 10.3.3a, 10.3.3b, 10.3.3c and 10.3.4:

1. Refer to Chapter 8 for detailed description of activities.
2. Number of operators may be set to 1 to simplify calculations where the duration is indirectly proportional to the number of operators. The total dose is equivalent in both respects.
3. HI-STAR 100 Operations assume that the cooling time is at least 10 years.

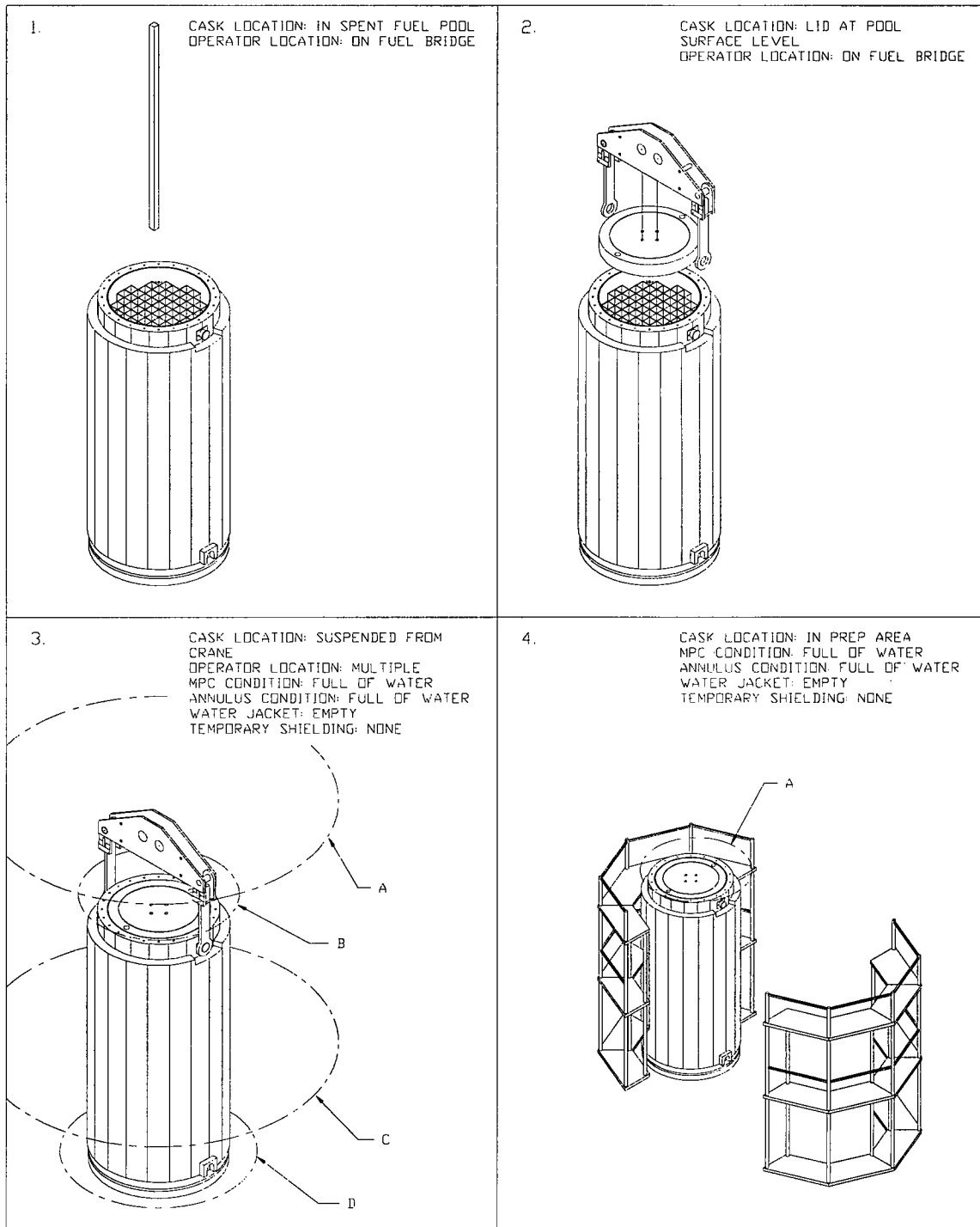


Figure 10.3.1a; Operator Work Locations Used for Estimating Personnel Exposure

HOLTEC INTERNATIONAL COPYRIGHTED MATERIAL

HI-STORM FSAR
REPORT HI-2002444

Rev. 4

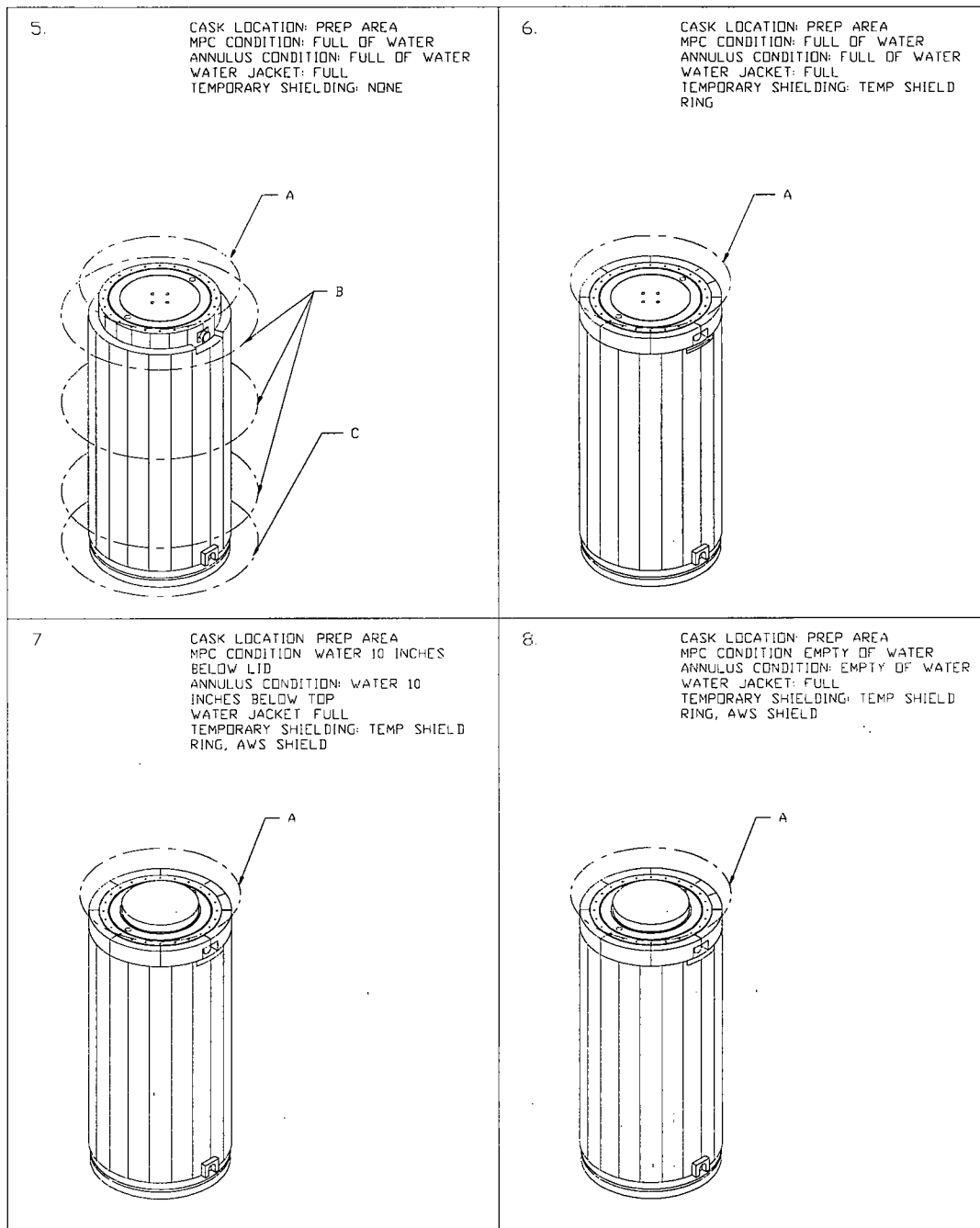


Figure 10.3.1b; Operator Work Locations Used for Estimating Personnel Exposure

HOLTEC INTERNATIONAL COPYRIGHTED MATERIAL

HI-STORM FSAR
REPORT HI-2002444

Rev. 4

HI-STORM 100 FSAR, NON-PROPRIETARY
REVISION 12
MARCH 12, 2014

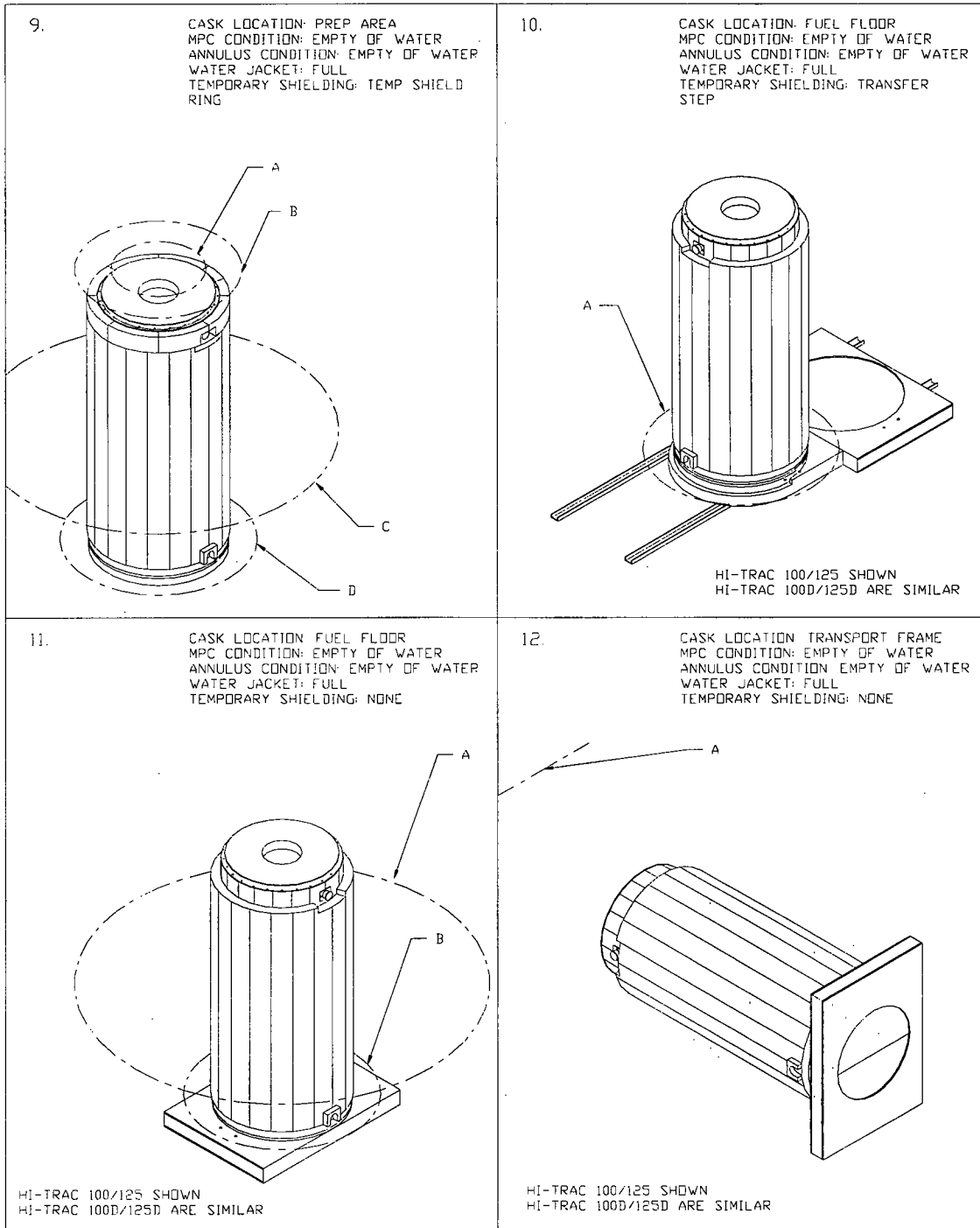


Figure 10.3.1c; Operator Work Locations Used for Estimating Personnel Exposure

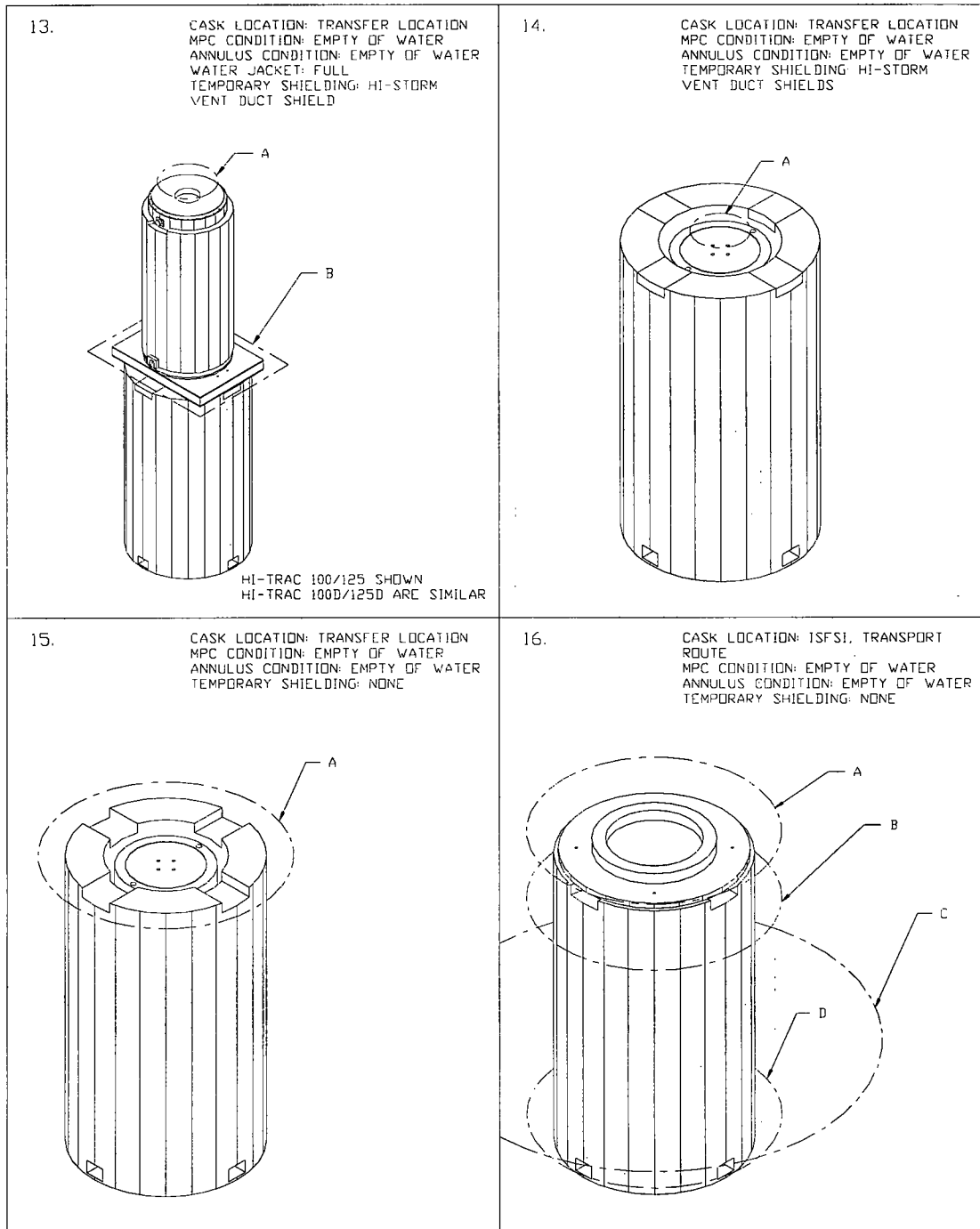


Figure 10.3.1d; Operator Work Locations Used for Estimating Personnel Exposure

HOLTEC INTERNATIONAL COPYRIGHTED MATERIAL

HI-STORM FSAR
REPORT HI-2002444

Rev. 4

HI-STORM 100 FSAR, NON-PROPRIETARY
REVISION 12
MARCH 12, 2014

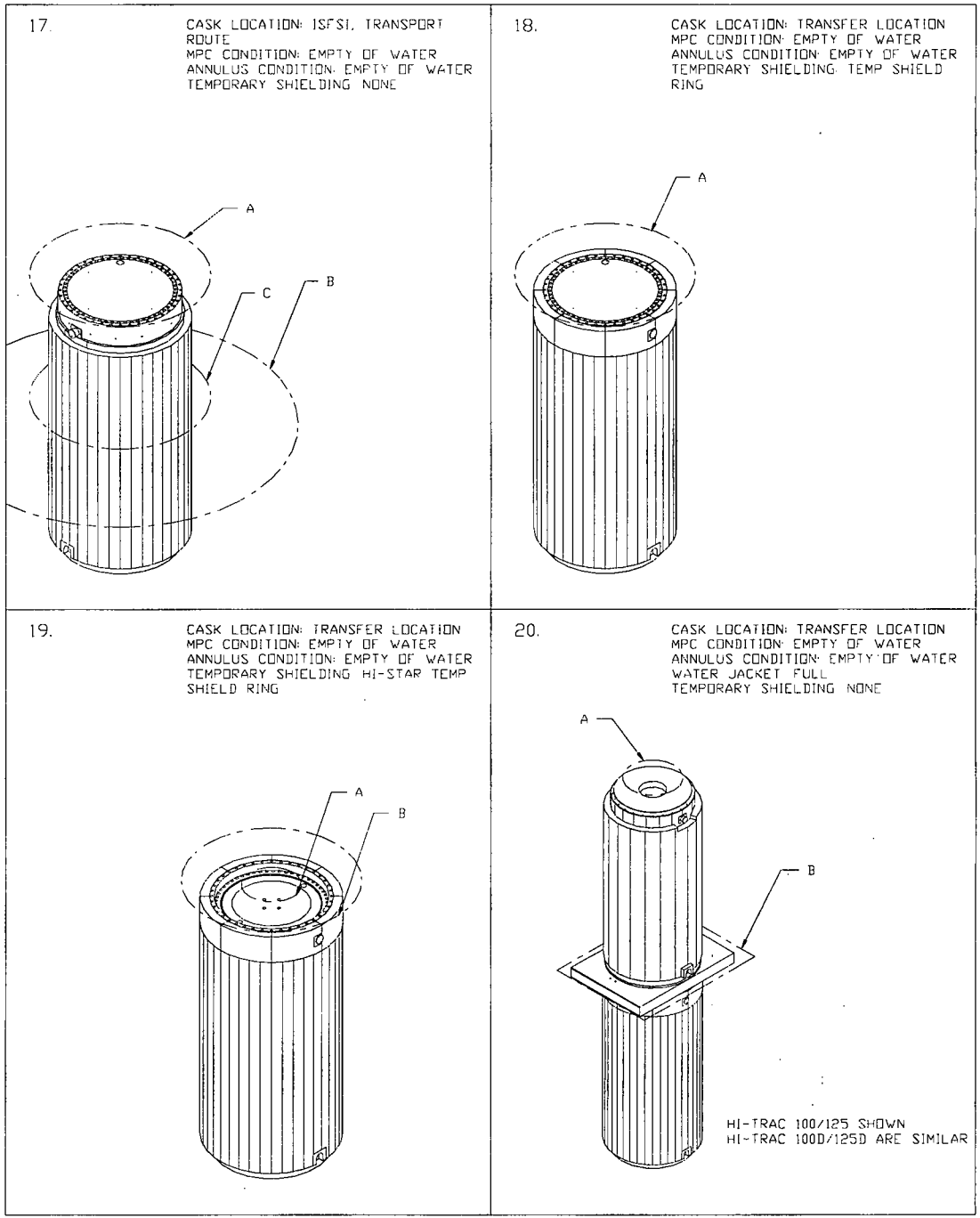


Figure 10.3.1e; Operator Work Locations Used for Estimating Personnel Exposure

10.4 ESTIMATED COLLECTIVE DOSE ASSESSMENT

10.4.1 Controlled Area Boundary Dose for Normal Operations

10CFR72.104 [10.0.1] limits the annual dose equivalent to any real individual at the controlled area boundary to a maximum of 25 mrem to the whole body, 75 mrem to the thyroid, and 25 mrem for any other critical organ. This includes contributions from all uranium fuel cycle operations in the region.

It is not feasible to predict bounding controlled area boundary dose rates on a generic basis since radiation from plant and other sources; the location and the layout of an ISFSI; and the number and configuration of casks are necessarily site-specific. In order to compare the performance of the HI-STORM 100 System with the regulatory requirements, sample ISFSI arrays were analyzed in Chapter 5. These represent a full array of design basis fuel assemblies. Users are required to perform a site specific dose analysis for their particular situation in accordance with 10CFR72.212 [10.0.1]. The analysis must account for the ISFSI (size, configuration, fuel assembly specifics) and any other radiation from uranium fuel cycle operations within the region.

Table 5.1.9 presents dose rates at various distances from sample ISFSI arrays for the design basis burnup and cooling time which results in the highest off-site dose for the combination of maximum burnup and minimum cooling times analyzed in Chapter 5. 10CFR72.106 [10.0.1] specifies that the minimum distance from the ISFSI to the controlled area boundary is 100 meters. Therefore this was the minimum distance analyzed in Chapter 5. As a summary of Chapter 5, Table 10.4.1 presents the annual dose results for a single overpack at 100 and 350 meters and a 2x5 array of HI-STORM 100 systems at 550 meters. These annual doses are based on a full array of design basis fuel with a burnup of 60,000 MWD/MTU and 3-year cooling. This burnup and cooling time combination conservatively bounds the allowable burnup and cooling times listed in Section 2.1.9. In addition, 100% occupancy (8760 hours) is conservatively assumed. In the calculation of the annual dose, the casks were positioned on an infinite slab of soil to account for earth-shine effects. These results indicate that the calculated annual dose is less than the regulatory limit of 25 mrem/year at a distance of 350 meters for a single cask and at 550 meters for a 2x5 array of HI-STORM 100 Systems containing design basis fuel. These results are presented only as an illustration to demonstrate that the HI-STORM 100 System is in compliance with 10CFR72.104[10.0.1]. Neither the distances nor the array configurations become part of the Technical Specifications. Rather, users are required to perform a site specific analyses to demonstrate compliance with 10CFR72.104[10.0.1] contributors and 10CFR20[10.1.1].

An additional contributor to the controlled area boundary dose is the loaded HI-TRAC transfer cask, if the HI-TRAC is to be used at the ISFSI outside of the fuel building. Table 10.4.2 provides dose rates at 100, 200, and 300 meters for a 100-ton HI-TRAC transfer cask loaded with design basis fuel. The 100-ton HI-TRAC dose rates bound the 125-ton HI-TRAC by large margins. Based on the short duration that the loaded HI-TRAC is used outside at the ISFSI, the HI-STORM 100 System is in compliance with

10CFR72.104[10.0.1] when worst-case design basis fuel is loaded in all fuel cell locations. However, users are required to perform a site specific analysis to demonstrate compliance with 10CFR72.104[10.0.1] and 10CFR20[10.1.1] taking into account the actual site boundary distance and fuel characteristics.

Section 7.1 provides a discussion as to how the Holtec MPC design, welding, testing, and inspection requirements meet the guidance of ISG-18 such that leakage from the confinement boundary may be considered non-credible. Therefore, there is no additional dose contribution due to leakage from the welded MPC. The site licensee is required to perform a site-specific dose evaluation of all dose contributors as part of the ISFSI design. This evaluation will account for the location of the controlled area boundary, the total number of casks on the ISFSI and the effects of the radiation from uranium fuel cycle operations within the region.

10.4.2 Controlled Area Boundary Dose for Off-Normal Conditions

As demonstrated in Section 11.1, the postulated off-normal conditions (off-normal pressure, off-normal environmental temperatures, leakage of one MPC weld, partial blockage of air inlets, and off-normal handling of HI-TRAC) do not result in the degradation of the HI-STORM 100 System shielding effectiveness. Therefore, the dose at the controlled area boundary from direct radiation for off-normal conditions is equal to that of normal conditions.

10.4.3 Controlled Area Boundary Dose for Accident Conditions

10CFR72.106 [10.0.1] specifies the maximum doses allowed to any individual at the controlled area boundary from any design basis accident (See Subsection 10.1.2). In addition, it is specified that the minimum distance from the ISFSI to the controlled area boundary be at least 100 meters.

Chapter 11 presents the results of the evaluations performed to demonstrate that the HI-STORM 100 System can withstand the effects of all accident conditions and natural phenomena without the corresponding radiation doses exceeding the requirements of 10CFR72.106 [10.0.1]. The accident events addressed in Chapter 11 include: handling accidents, tip-over, fire, tornado, flood, earthquake, 100 percent fuel rod rupture, confinement boundary leakage, explosion, lightning, burial under debris, extreme environmental temperature, partial blockage of MPC basket air inlets, and 100% blockage of air inlets.

The worst-case shielding consequence of the accidents evaluated in Section 11.2 for the loaded HI-STORM overpack assumes that as a result of a fire, the outer-most one inch of the concrete experiences temperatures above the concrete's design temperature. Therefore, the shielding effectiveness of this outer-most one inch of concrete is degraded. However, with over 25 inches of concrete providing shielding, the loss of one inch will have a negligible effect on the dose at the controlled area boundary.

HOLTEC INTERNATIONAL COPYRIGHTED MATERIAL

The worst case shielding consequence of the accidents evaluated in Section 11.2 for the loaded HI-TRAC transfer cask assumes that as a result of a fire, tornado missile, or handling accident, the all the water in the water jacket is lost. The shielding analysis of the 100-ton HI-TRAC transfer cask with complete loss of the water from the water jacket is discussed in Section 5.1.2. These results bound those for the 125-Ton HI-TRAC transfer cask by a large margin. The results in that section show that the resultant dose rate at the 100-meter controlled area boundary would be approximately 4.22 mrem/hour for the loaded HI-TRAC transfer cask during the accident condition. At the calculated dose rate, it would take approximately 49 days for the dose at the controlled area boundary to reach 5 rem. This length of time is sufficient to implement and complete the corrective actions outlined in Chapter 11. Therefore, the dose requirement of 10CFR72.106 [10.0.1] is satisfied. Once again, this dose is calculated assuming design basis fuel in all fuel cell locations. Users will need to perform site-specific analysis considering the actual site boundary distance and fuel characteristics.

HOLTEC INTERNATIONAL COPYRIGHTED MATERIAL

HI-STORM FSAR

REPORT HI-2002444

HI-STORM 100.FSAR, NON-PROPRIETARY

REVISION 12

MARCH 12, 2014

10.4-3

Rev. 7

Table 10.4.1

ANNUAL DOSE FOR ARRAYS OF HI-STORM 100S VERSION B OVERPACKS
WITH DESIGN BASIS ZIRCALOY CLAD FUEL
60,000 MWD/MTU AND 3-YEAR COOLING

Array Configuration	1 Cask	1 Cask	2x5 Array
Annual Dose (mrem/year) [†]	883.27	19.26	16.34
Distance to Controlled Area Boundary (meters) ^{††, †††}	100	350	550

† 100% occupancy is assumed.

†† Dose location is at the center of the long side of the array.

††† Actual controlled area boundary dose rates will be lower because the maximum permissible burnup for 3-year cooling as specified in the Section 2.1.9 is lower than the burnup analyzed for the design basis fuel used in this table.

Table 10.4.2
DOSE RATE FOR THE 100-TON HI-TRAC TRANSFER CASK
WITH DESIGN BASIS ZIRCALOY CLAD FUEL

Fuel Burnup & Cooling Time	100 Meters	200 Meters	300 Meters
60,000 MWD/MTU & 3 Years	0.91 mrem/hr	0.14 mrem/hr	0.04 mrem/hr

HOLTEC INTERNATIONAL COPYRIGHTED MATERIAL

HI-STORM FSAR

REPORT HI-2002444

HI-STORM 100 FSAR, NON-PROPRIETARY

REVISION 12

MARCH 12, 2014

10.4-5

Rev. 7

10.5 REFERENCES

- [10.0.1] *U.S. Code of Federal Regulations*, Title 10, "Energy" Part 72 "Licensing Requirements for Independent Storage of Spent Nuclear Fuel and High-Level Radioactive Waste."
- [10.1.1] *U.S. Code of Federal Regulations*, Title 10, "Energy" Part 20 "Standards for Protection Against Radiation."
- [10.1.2] U.S. Nuclear Regulatory Commission "Information Relevant to Ensuring that Occupational Radiation Exposures at Nuclear Power at Nuclear Power Stations will be As Low As Reasonably Achievable", Regulatory Guide 8.8, June 1978.
- [10.1.3] U.S. Nuclear Regulatory Commission, "Operating Philosophy for Maintaining Occupational Radiation Exposures As Low As is Reasonably Achievable", Regulatory Guide 8.10, Revision 1-R, May 1997.

HOLTEC INTERNATIONAL COPYRIGHTED MATERIAL

HI-STORM FSAR
REPORT HI-2002444

10.5-1

Rev. 0

HI-STORM 100 FSAR, NON-PROPRIETARY
REVISION 12
MARCH 12, 2014

SUPPLEMENT 10.I

RADIATION PROTECTION

The HI-STORM 100U is a modular, underground vertical ventilated module (VVM) designed to accept all MPC models for storage at an ISFSI in lieu of above ground overpacks, like the HI-STORM 100 and HI-STORM 100S. As such, the radiological dose to plant personnel as well as members of the general public is well below those of the HI-STORM 100 and HI-STORM 100S when the MPC is in the overpack. Since the determination of off-site doses is necessarily site-specific, dose assessments similar to those described in Chapter 10 are to be prepared by the licensee as part of implementing the HI-STORM 100U System in accordance with 10CFR72.212 [10.0.1].

HI-STORM 100U Loading and Unloading Operations

The operations associated with the use of the HI-STORM 100U, described in Supplements 1.I and 8.I, are quite similar to the operations for all other variations of the HI-STORM 100 system. In both the aboveground and underground overpack, the MPC is transferred between the HI-TRAC and the overpack and in both cases the lid of the overpack is placed atop the overpack once the HI-TRAC is removed from the overpack. The only significant difference between the aboveground and underground overpack is the position of the HI-TRAC relative to ground level. For the aboveground overpack, the bottom of the HI-TRAC is approximately 18 feet above the ground and for the underground overpack, the bottom of the HI-TRAC is essentially at ground level. From an operations perspective, it will be easier to access the mating device and the pool lid bolts when the HI-TRAC is positioned atop the underground overpack rather than the aboveground overpack. In both cases, the same bolting and unbolting operations around the base of the HI-TRAC must be performed. Therefore, the estimated occupational dose for these scenarios is the same. The fact that the body of the HI-TRAC is closer to the ground when the underground overpack is being loaded will not affect the occupational dose rate since it is assumed that the workers not performing a task are positioned far enough away as to receive minimal dose.

Once the MPC transfer is complete and the HI-TRAC has been removed, the lid is placed on the overpack. For the underground overpack, this is a relatively simple operation of lifting the lid and placing it in the correct location. Unlike the aboveground overpack, the lid is not bolted to the body of the overpack. However, the outlet vent cover is installed on the overpack lid after the lid is placed upon the HI-STORM 100U, which installation requires bolting. Installation of the outlet vent cover places workers over the lid and adds some time to the operation. The duration of this operation can be estimated based on information provided in the tables in Section 10.3. Installation of the vent cover would be similar to the installation and alignment of the closure ring on top of the MPC. This activity is listed with an estimated duration of 5 min, for a single operator, in the tables in Section 10.3. Since the outlet vent cover is closer to the center of the lid than the closure ring, it is assumed here that two operators are required. There are four bolts, and bolt installation is typically listed in Section 10.3 to be performed at 2 bolts per minute, resulting in a duration of 2 minutes. Again, due to the location of those bolts, it is assumed that two

HOLTEC INTERNATIONAL COPYRIGHTED MATERIAL

operators are necessary to perform this activity. In total, it is then conservatively estimated that it will take 10 minutes for two operators to perform the installation. The dose rate on top of the overpack lid is 31.53 mrem/hr (see Table 5.1.1), which translates to a dose to the individual of 5.26 mrem and a total dose of 10.51 person-mrem. This is a small increase (about 1 %) in the total dose when considering the entire MPC transfer into the HI-STORM system. However, it is recommended that the operators do not spend any unnecessary time on top of the lid to ensure/meet the ALARA principle. It should also be mentioned that actual occupational dose during loading vary widely depending on site specific conditions. Experience has shown that the dose rates are in general significantly lower than those estimated in Chapter 10 of this FSAR.

In conclusion, the operator dose rates will be similar to those described in Chapter 10 for the aboveground overpack. Therefore, occupational exposure estimates for typical canister loading, closure, transfer operations, and ISFSI inspections may be calculated using the information presented in the tables of Chapter 10 for the site-specific application of the HI-STORM 100U system. For the fuel loading/unloading, transportation, and storage operations utilizing the HI-STORM 100U, the dose information provided in Chapter 10 may be considered bounding.

Excavation Activities

In the event it is desired to expand a loaded ISFSI utilizing the HI-STORM 100U design, excavation of material (i.e., soil) in the vicinity of the ISFSI is required. Radiation protection during excavation activities is achieved by prescribing a minimum proximity of any excavation activity to an existing operating HI-STORM 100U array. As described in 3.I.4.4 (iv), two scenarios may exist:

- (i) **No Retaining Wall Installed:** In this case, a minimum distance from the loaded ISFSI, called the Excavation Exclusion Zone (EEZ) is established based on the site specific subgrade and earthquake data using the methodology described in subsection 3.I.4.7. The EEZ ensures that the subgrade around the operating ISFSI will remain unaffected by the excavation during an earthquake. The required distance from the ISFSI for the EEZ is influenced by the properties of the subgrade and the strength of the DBE for the site. The EEZ must lie outside the Radiation Protection Space (RPS) defined as the spatial region around the ISFSI specified to provide radiation protection and safety from tornado missiles, shown on the licensing drawing.
- (ii) **Retaining Wall Installed:** If a retaining wall is installed at or beyond the Radiation Protection Space (RPS) per the licensing drawing and Table 2.I.2 then the EEZ boundary is at the retaining wall and excavation may occur up to the retaining wall as long as the depth of the excavation does not exceed the level of the bottom of the Support Foundation Pad. A retaining wall may be installed on any or all sides of the ISFSI. Site specific radiation protection measures for excavation activities need to include confirmation of the minimum soil properties along with the minimum distances between the excavation area and the loaded VVMs, as well as radiological monitoring of the excavation area.

Site specific evaluations also need to be performed to ensure that the radiation protection space boundary is maintained. Site specific accident scenarios (e.g., seismic conditions) will need to be accounted for in these evaluations. A general accident scenario evaluation, however, has been performed for the HI-STORM 100U design.

The impact of a tornado missile penetrating the soil creating a horizontal hole extending from the metal surface of the VVM to the outer surface of the soil was also considered. This evaluation, presented in Supplement 5.I, demonstrates that the dose at the site boundary is below the limit specified in 10 CFR 72.

Normal Operation of Storage

During normal operation of storage, radiation will predominantly emanate from the inlet and outlet vents and the top of the lid. However, there are also some additional radiation streaming paths and scenarios that may have to be considered in the radiation protection program. The following two scenarios have been evaluated for the HI-STORM 100U design.

The first scenario evaluated address radiation streaming from a loaded VVM through an adjacent empty VVM. An empty VVM adjacent to a loaded VVM could potentially constitute a radiation streaming path since the soil providing shielding is limited between adjacent VVMs. Therefore, radiation passing through the soil to the unloaded VVM will have a path of less shielding and could contribute to occupational dose. This evaluation is presented in detail in Supplement 5.I, and concluded that there are no concerns about the dose rates contributing to occupational dose across the top of the empty VVM due to radiation streaming from the loaded neighboring VVM.

The second scenario concerns the soil access tube, or test station, that is part of the ICCPS design (see Figure 2.I.1) and could represent a potential streaming path. Therefore, radiation passing through the soil access tube could contribute to occupational dose. This evaluation is presented in detail in Supplement 5.I, and assumes a tube located about 5.5 feet from the center of the VVM with a diameter of 4 inches, that reaches down to the support foundation. With these dimensions, it is shown that there are no concerns about the dose rates contributing to occupational dose on the top of the soil access tube due to radiation streaming from a loaded VVM. However, if the tube is larger or located closer to the VVM, then the actual dimensions should be considered in the site specific dose rate calculations, and the result of the calculations should be considered in the site specific radiation protection program.

SUPPLEMENT 10.III

RADIATION PROTECTION FOR THE MPC-68M

The main body of this chapter remains fully applicable for the HI-STORM 100 System using the MPC-68M.

The MPC-68M basket is lighter than the generic MPC-68 basket. This is due to the lower density of the Metamic-HT panels as compared to stainless steel. The reduction in weight provides the user more flexibility to meet ALARA objectives. For example, additional temporary shielding may be used to further reduce the dose rates around the HI-TRAC when performing short term operations.

HOLTEC INTERNATIONAL COPYRIGHTED MATERIAL

CHAPTER 11[†]: ACCIDENT ANALYSIS

This chapter presents the evaluation of the HI-STORM 100 System for the effects of off-normal and postulated accident conditions. The design basis off-normal and postulated accident events, including those resulting from mechanistic and non-mechanistic causes as well as those caused by natural phenomena, are identified in Subsections 2.2.2 and 2.2.3. For each postulated event, the event cause, means of detection, consequences, and corrective action are discussed and evaluated. As applicable, the evaluation of consequences includes structural, thermal, shielding, criticality, confinement, and radiation protection evaluations for the effects of each design event.

The structural, thermal, shielding, criticality, and confinement features and performance of the HI-STORM 100 System are discussed in Chapters 3, 4, 5, 6, and 7. The evaluations provided in this chapter are based on the design features and evaluations described therein.

Chapter 11 is in full compliance with NUREG-1536; no exceptions are taken.

11.1 OFF-NORMAL CONDITIONS

Off-normal operations, as defined in accordance with ANSI/ANS-57.9, are those conditions, which, although not occurring regularly, are expected to occur no more than once a year. In this section, design events pertaining to off-normal operation for expected operational occurrences are considered. The off-normal conditions are listed in Subsection 2.2.2.

The following off-normal operation events have been considered in the design of the HI-STORM 100:

- Off-Normal Pressure
- Off-Normal Environmental Temperature
- Leakage of One MPC Seal Weld
- Partial Blockage of Air Inlets
- Off-Normal Handling of HI-TRAC Transfer Cask
- Malfunction of FHD System
- SCS Power Failure
- Off-Normal Loads[‡]

[†] This chapter has been prepared in the format and section organization set forth in Regulatory Guide 3.61. However, the material content of this chapter also fulfills the requirements of NUREG-1536. Pagination and numbering of sections, figures, and tables are consistent with the convention set down in Chapter 1, Section 1.0, herein. Finally, all terms-of-art used in this chapter are consistent with the terminology of the glossary (Table 1.0.1). This chapter has been substantially revised in support of LAR#3 to enhance clarity of presentation and evaluation of results. Because of extensive editing a clean chapter is issued with this amendment.

[‡] Off-normal load combinations are defined in Chapter 2, Table 2.2.14 and evaluated in Chapter 3, Section 3.4.

HI-TRAC Off-Normal Ambient Temperature

For each event, the postulated cause of the event, detection of the event, analysis of the event effects and consequences, corrective actions, and radiological impact from the event are presented.

The results of the evaluations performed herein demonstrate that the HI-STORM 100 System can withstand the effects of off-normal events without affecting function, and are in compliance with the applicable acceptance criteria. The following subsections present the evaluation of the HI-STORM 100 System for the design basis off-normal conditions that demonstrate that the requirements of 10CFR72.122 are satisfied, and that the corresponding radiation doses satisfy the requirements of 10CFR72.104(a) and 10CFR20.

11.1.1 Off-Normal Pressures

The sole pressure boundary in the HI-STORM 100 System is the MPC enclosure vessel. The off-normal pressure condition is specified in Subsection 2.2.2. The off-normal pressure for the MPC internal cavity is a function of the initial helium fill pressure and the temperature reached within the MPC cavity under normal storage. The MPC internal pressure is evaluated with 10% of the fuel rods ruptured and 100% of the rods fill gas and 30% of the fission gases released to the cavity.

11.1.1.1 Postulated Cause of Off-Normal Pressure

After fuel assembly loading, the MPC is drained, dried, and backfilled with an inert gas (helium) to assure long-term fuel cladding integrity during dry storage. Therefore, the probability of failure of intact fuel rods in dry storage is low. Nonetheless, the event is postulated and evaluated.

11.1.1.2 Detection of Off-Normal Pressure

The HI-STORM 100 System is designed to withstand the MPC off-normal internal pressure without any effects on its ability to meet its safety requirements. There is no requirement for detection of off-normal pressure and, therefore, no monitoring is required.

11.1.1.3 Analysis of Effects and Consequences of Off-Normal Pressure

The MPC off normal internal pressure is reported in Subsection 4.6.1 for the following conditions: limiting fuel storage scenario, tech. spec. maximum helium backfill and 10% rod rupture with 100% of rod fill gas and 30% of gaseous fission products released into the MPC cavity. The analysis shows that the MPC pressure remains below the design MPC internal pressure (Table 2.2.1).

It should be noted that this bounding temperature rise does not take any credit for the increase in thermosiphon action that would accompany the pressure increase that results from both the temperature rise and the addition of the gaseous fission products to the MPC cavity. As any such increase in thermosiphon action would decrease the temperature rise, the calculated pressure is higher than would actually occur.

HOLTEC INTERNATIONAL COPYRIGHTED MATERIAL

Structural

The structural evaluation of the MPC enclosure vessel for off-normal internal pressure conditions is discussed in Section 3.4. The stresses resulting from the off-normal pressure are confirmed to be bounded by the applicable pressure boundary stress limits.

Thermal

The MPC internal pressure for off-normal conditions is reported in Subsection 4.6.1. The design basis internal pressure for off-normal conditions used in the structural evaluation (Table 2.2.1) bounds the off-normal condition pressure. .

Shielding

There is no effect on the shielding performance of the system as a result of this off-normal event.

Criticality

There is no effect on the criticality control features of the system as a result of this off-normal event.

Confinement

There is no effect on the confinement function of the MPC as a result of this off-normal event. As discussed in the structural evaluation above, all stresses remain within allowable values, assuring confinement boundary integrity.

Radiation Protection

Since there is no degradation in shielding or confinement capabilities as discussed above, there is no effect on occupational or public exposures as a result of this off-normal event.

Based on this evaluation, it is concluded that the off-normal pressure does not affect the safe operation of the HI-STORM 100 System.

11.1.1.4 Corrective Action for Off-Normal Pressure

The HI-STORM 100 System is designed to withstand the off-normal pressure without any effects on its ability to maintain safe storage conditions. There is no corrective action requirement for off-normal pressure.

11.1.1.5 Radiological Impact of Off-Normal Pressure

The event of off-normal pressure has no radiological impact because the confinement barrier and shielding integrity are not affected.

11.1.2 Off-Normal Environmental Temperatures

The HI-STORM 100 System is designed for use at any site in the United States. Off-normal environmental temperatures of -40 to 100°F (HI-STORM overpack) and 0 to 100°F (HI-TRAC transfer cask) have been conservatively selected to bound off-normal temperatures at these sites. The off-normal temperature range affects the entire HI-STORM 100 System and must be evaluated against the allowable component design temperatures. The off-normal temperatures are evaluated against the off-normal condition temperature limits listed in Table 2.2.3.

11.1.2.1 Postulated Cause of Off-Normal Environmental Temperatures

The off-normal environmental temperature is postulated as a constant ambient temperature caused by extreme weather conditions. To determine the effects of the off-normal temperatures, it is conservatively assumed that these temperatures persist for a sufficient duration to allow the HI-STORM 100 System to achieve thermal equilibrium. Because of the large mass of the HI-STORM 100 System with its corresponding large thermal inertia and the limited duration for the off-normal temperatures, this assumption is conservative.

11.1.2.2 Detection of Off-Normal Environmental Temperatures

The HI-STORM 100 System is designed to withstand the off-normal environmental temperatures without any effects on its ability to maintain safe storage conditions. There is no requirement for detection of off-normal environmental temperatures for the HI-STORM overpack and MPC. Chapter 2 provides operational limitations to the use of the HI-TRAC transfer cask at temperatures of $\leq 32^\circ\text{F}$ and prohibits use of the HI-TRAC transfer cask below 0°F .

11.1.2.3 Analysis of Effects and Consequences of Off-Normal Environmental Temperatures

The off-normal event considers an environmental temperature of 100°F with insolation for a duration sufficient to reach thermal equilibrium. The evaluation is performed for a limiting fuel storage configuration. The Off-Normal ambient temperature condition is evaluated in Subsection 4.6.1. The results are in compliance with off-normal temperature and pressure limits in Tables 2.2.1 and 2.2.3.

The off-normal event considering an environmental temperature of -40°F and no solar insolation for a duration sufficient to reach thermal equilibrium is evaluated with respect to material design temperatures of the HI-STORM overpack. The HI-STORM overpack and MPC are conservatively assumed to reach -40°F throughout the structure. The minimum off-normal environmental temperature specified for the HI-TRAC transfer cask is 0°F and the HI-TRAC is conservatively assumed to reach 0°F throughout the structure. For ambient temperatures from 0° to 32°F , antifreeze must be added to the demineralized water in the water jacket to prevent freezing. Chapter 3, Subsection 3.1.2, details the structural analysis and testing performed to assure prevention of brittle fracture failure of the HI-STORM 100 System.

Structural

The effect on the MPC for the upper off-normal thermal conditions (i.e., 100°F) is an increase in the internal pressure. As shown in Subsection 4.6.1, the resultant pressure is below the off-normal design pressure (Table 2.2.1). The effect of the lower off-normal thermal conditions (i.e., -40°F) requires an evaluation of the potential for brittle fracture. Such an evaluation is presented in Subsection 3.1.2.

Thermal

The resulting off-normal system and fuel assembly cladding temperatures for the hot conditions are provided in Subsection 4.6.1 for the HI-STORM overpack and MPC. As can be seen from this table, all temperatures for the off-normal environmental temperatures event are within the allowable values for off-normal conditions listed in Table 2.2.3.

Shielding

There is no effect on the shielding performance of the system as a result of this off-normal event.

Criticality

There is no effect on the criticality control features of the system as a result of this off-normal event.

Confinement

There is no effect on the confinement function of the MPC as a result of this off-normal event.

Radiation Protection

Since there is no degradation in shielding or confinement capabilities as discussed above, there is no effect on occupational or public exposures as a result of this off-normal event.

Based on this evaluation, it is concluded that the specified off-normal environmental temperatures do not affect the safe operation of the HI-STORM 100 System.

11.1.2.4 Corrective Action for Off-Normal Environmental Temperatures

The HI-STORM 100 System is designed to withstand the off-normal environmental temperatures without any effects on its ability to maintain safe storage conditions. There are no corrective actions required for off-normal environmental temperatures.

11.1.2.5 Radiological Impact of Off-Normal Environmental Temperatures

Off-normal environmental temperatures have no radiological impact, as the confinement barrier and shielding integrity are not affected.

HOLTEC INTERNATIONAL COPYRIGHTED MATERIAL

11.1.3 Leakage of One Seal

The HI-STORM 100 System has a reliable welded boundary to contain radioactive fission products within the confinement boundary. The radioactivity confinement boundary is defined by the MPC shell, baseplate, MPC lid, vent and drain port cover plates, and associated welds. The closure ring provides a redundant welded closure to the release of radioactive material from the MPC cavity through the field-welded MPC lid closures. Confinement boundary welds are inspected by radiography or ultrasonic examination except for field welds that are examined by the liquid penetrant method on the root (for multi-pass welds) and final pass, at a minimum. Field welds are performed on the MPC lid, the MPC vent and drain port covers, and the MPC closure ring. **The welds on the vent and drain port cover plates are leakage tested.** Additionally, the MPC lid weld is subjected to a pressure test to verify its integrity.

Section 7.1 provides a discussion as to how the MPC design, welding, testing and inspection requirements meet the guidance of ISG-18 such that leakage from the confinement boundary may be considered non-credible.

11.1.3.1 Postulated Cause of Leakage of One Seal in the Confinement Boundary

There is no credible cause for the leakage of one seal in the confinement boundary. The conditions analyzed in Chapter 3 shows that the confinement boundary components are maintained within their Code-allowable stress limits under all normal and off-normal storage conditions. **The MPC lid-to-shell weld meets** the requirements of ISG-18, such that leakage from the confinement boundary is not considered credible. Therefore, there is no event that could cause leakage of one seal in the confinement boundary.

11.1.3.2 Detection of Leakage of One Seal in the Confinement Boundary

The HI-STORM 100 System is designed such that leakage of one seal in the confinement boundary is not considered a credible scenario. Therefore, there is no requirement to detect leakage from one seal.

11.1.3.3 Corrective Action for Leakage of One Seal in the Confinement Boundary

There is no corrective action required for the failure of one weld in the closure system of the confinement boundary. Leakage of one weld in the confinement boundary closure system is not a credible event.

11.1.3.4 Radiological Impact of Leakage of One Seal in the Confinement Boundary

The off-normal event of the failure of one weld in the confinement boundary closure system has no radiological impact because leakage from the confinement barrier is not credible.

11.1.4 Partial Blockage of Air Inlets

The HI-STORM 100 System is designed with debris screens on the inlet and outlet air ducts. These screens ensure the air ducts are protected from the incursion of foreign objects. There are four air inlet ducts 90° apart and it is highly unlikely that blowing debris during normal or off-normal operation could block all air inlet ducts. As required by the design criteria presented in Chapter 2, it is conservatively assumed that two of the four air inlet ducts are blocked. The blocked air inlet ducts are assumed to be completely blocked with an ambient temperature of 80°F (Table 2.2.2), full solar insolation, and maximum SNF decay heat values. This condition is analyzed to demonstrate the inherent thermal stability of the HI-STORM 100 System.

11.1.4.1 Postulated Cause of Partial Blockage of Air Inlets

It is conservatively assumed that the blocked air inlet ducts are completely blocked, although screens prevent foreign objects from entering the ducts. The screens are either inspected periodically or the outlet duct air temperature is monitored. It is, however, possible that blowing debris may block two air inlet ducts of the overpack.

11.1.4.2 Detection of Partial Blockage of Air Inlets

The detection of the partial blockage of air inlet ducts will occur during the routine visual inspection of the screens or temperature monitoring of the outlet duct air. The frequency of inspection is based on an assumed complete blockage of all four air inlet ducts. There is no inspection requirement as a result of the postulated two inlet duct blockage, because the complete blockage of all four air inlet ducts is bounding.

11.1.4.3 Analysis of Effects and Consequences of Partial Blockage of Air Inlets

Structural

There are no structural consequences as a result of this off-normal event.

Thermal

The thermal analysis for the two air inlet ducts blocked off-normal condition is performed in Subsection 4.6.1. The analysis demonstrates that under bounding (steady-state) conditions, no system components exceed the off-normal temperature limits in Table 2.2.3.

Shielding

There is no effect on the shielding performance of the system as a result of this off-normal event.

Criticality

There is no effect on the criticality control features of the system as a result of this off-normal event.

Confinement

There is no effect on the confinement function of the MPC as a result of this off-normal event.

Radiation Protection

Since there is no degradation in shielding or confinement capabilities as discussed above, there is no effect on occupational or public exposures as a result of this off-normal event.

Based on this evaluation, it is concluded that the specified off-normal partial blockage of air inlet ducts event does not affect the safe operation of the HI-STORM 100 System.

11.1.4.4 Corrective Action for Partial Blockage of Air Inlets

The corrective action for the partial blockage of air inlet ducts is the removal, cleaning, and replacement of the affected mesh screens. After clearing of the blockage, the storage module temperatures will return to the normal temperatures reported in Chapter 4. Partial blockage of air inlet ducts does not affect the HI-STORM 100 System's ability to operate safely.

Periodic inspection of the HI-STORM overpack air duct screens is required. Alternatively, the outlet duct air temperature is monitored. The frequency of inspection is based on an assumed blockage of all four air inlet ducts analyzed in Section 11.2.

11.1.4.5 Radiological Impact of Partial Blockage of Air Inlets

The off-normal event of partial blockage of the air inlet ducts has no radiological impact because the confinement barrier is not breached and shielding is not affected.

11.1.5 Off-Normal Handling of HI-TRAC

During upending and/or downending of the HI-TRAC transfer cask, the total lifted weight is distributed among both the upper lifting trunnions and the lower pocket trunnions. Each of the four trunnions on the HI-TRAC therefore supports approximately one-quarter of the total weight. This even distribution of the load would continue during the entire rotation operation.

If the lifting device is allowed to "go slack", the total weight would only be applied to the lower pocket trunnions. Under this off-normal condition, the pocket trunnions would each be required to support one-half of the total weight, doubling the load per trunnion. This condition is analyzed to demonstrate that the pocket trunnions possess sufficient strength to support the increased load under this off-normal condition.

This off-normal condition does not apply to the HI-TRAC 125D, which does not have lower pocket trunnions. Upending and downending of the HI-TRAC 125D is performed using an L-frame.

11.1.5.1 Postulated Cause of Off-Normal Handling of HI-TRAC

If the cable of the crane handling the HI-TRAC is inclined from the vertical, it would be possible to unload the upper lifting trunnions such that the lower pocket trunnions are supporting the total cask weight and the lifting trunnions are only preventing cask rotation.

11.1.5.2 Detection of Off-Normal Handling of HI-TRAC

Handling procedures and standard rigging practice call for maintaining the crane cable in a vertical position by keeping the crane trolley centered over the lifting trunnions. In such an orientation it is not possible to completely unload the lifting trunnions without inducing rotation. If the crane cable were inclined from the vertical, however, the possibility of unloading the lifting trunnions would exist. It is therefore possible to detect the potential for this off-normal condition by monitoring the incline of the crane cable with respect to the vertical.

11.1.5.3 Analysis of Effects and Consequences of Off-Normal Handling of HI-TRAC

If the upper lifting trunnions are unloaded, the lower pocket trunnions will support the total weight of the loaded HI-TRAC. The analysis of the pocket trunnions to support the applied load of one-half of the total weight is provided in Subsection 3.4.4. The consequence of off-normal handling of the HI-TRAC is that the pocket trunnions safely support the applied load.

Structural

The stress evaluations of the lower pocket trunnions are discussed in Subsection 3.4.4. All stresses are within the allowable values.

Thermal

There is no effect on the thermal performance of the system as a result of this off-normal event.

Shielding

There is no effect on the shielding performance of the system as a result of this off-normal event.

Criticality

There is no effect on the criticality control features of the system as a result of this off-normal event.

Confinement

There is no effect on the confinement function of the MPC as a result of this off-normal event.

Radiation Protection

Since there is no degradation in shielding or confinement capabilities as discussed above, there is no effect on occupational or public exposures as a result of this off-normal event.

Based on this evaluation, it is concluded that the specified off-normal handling of the HI-TRAC does not affect the safe operation of the system.

11.1.5.4 Corrective Action for Off-Normal Handling of HI-TRAC

The HI-TRAC transfer casks are designed to withstand the off-normal handling condition without any adverse effects. There are no corrective actions required for off-normal handling of HI-TRAC other than to attempt to maintain the crane cable vertical during HI-TRAC upending or downending.

11.1.5.5 Radiological Consequences of Off-Normal Handling of HI-TRAC

The off-normal event of off-normal handling of HI-TRAC has no radiological impact because the confinement barrier is not breached and shielding is not affected.

11.1.6 Malfunction of FHD System

The FHD system is a forced helium circulation device used to effectuate moisture removal from loaded MPCs. For circulating helium, the FHD system is equipped with active components requiring external power for normal operation.

11.1.6.1 Postulated Cause of FHD Malfunction

Likely causes of FHD malfunction are (i) a loss of external power to the FHD System and (ii) an active component trip. In both cases a stoppage of forced helium circulation occurs. Such a circulation stoppage does not result in any helium leakage from the MPC or the FHD itself.

11.1.6.2 Detection of FHD Malfunction

The FHD System is monitored during its operation. An FHD malfunction is detected by operator response to control panel visual displays and alarms.

11.1.6.3 Analysis of Effects and Consequences of FHD Malfunction

Structural

The FHD System is required to be equipped with safety relief devices§ to prevent the MPC structural boundary pressures from exceeding the design limits. Consequently there is no adverse effect.

Thermal

Malfunction of the FHD System is categorized as an off-normal condition, for which the applicable peak cladding temperature limit is 1058°F (Table 2.2.3). The FHD System malfunction event is evaluated assuming the following bounding conditions:

- 1) Steady state maximum temperatures have been reached
- 2) Design basis heat load
- 3) Standing column of air in the annulus
- 4) MPCs backfilled with the minimum helium pressure required by the Technical Specifications

It is noted that operator action may be required to raise the helium regulator set point to ensure that condition 4 above is satisfied. These conditions are the same as for the normal on-site transfer in a vertically oriented HI-TRAC, discussed in Section 4.5. The steady state results are provided in Table 4.5.4. The results demonstrate that the peak fuel cladding temperatures remain below the limit in the event of a prolonged unavailability of the FHD system.

Shielding

There is no effect on the shielding performance of the system as a result of this off-normal event.

Criticality

There is no effect on the criticality control of the system as a result of this off-normal event.

Confinement

There is no effect on the confinement function of the MPC as a result of this off-normal event. As discussed in the structural evaluation above, the structural boundary pressures cannot exceed the design limits.

§ The relief pressure is below the off-normal design pressure (Table 2.2.1) to prevent MPC overpressure and above 7 atm to enable MPC pressurization for adequate heat transfer.

Radiation Protection

As there is no adverse effect on the shielding or confinement functions, there is no effect on occupational or public exposures as a result of this off-normal event.

Based on this evaluation, it is concluded that the FHD malfunction does not affect the safe operation of the HI-STORM 100 System.

11.1.6.4 Corrective Action for FHD Malfunction

The HI-STORM 100 System is designed to withstand the FHD malfunction without an adverse effect on its safety functions. Consequently no corrective action is required.

11.1.6.5 Radiological Impact of FHD Malfunction

The event has no radiological impact because the confinement barrier and shielding integrity are not affected.

11.1.7 SCS Power Failure

The SCS system is a fluid circulation device used to provide supplemental HI-TRAC cooling. For fluid circulation, the SCS system is equipped with active components requiring power for normal operation.

11.1.7.1 Postulated Cause of SCS Power Failure

The SCS is normally operated from an external source of power such as from site utilities or a feed from a heavy haul vehicle carrying the HI-TRAC. Occasional interruption in power supply is possible.

11.1.7.2 Detection of SCS Power Failure

The HI-STORM 100 System is designed to withstand a power failure without affecting its ability to meet safety requirements. Consequently SCS monitoring and failure detection is not required.

11.1.7.3 Analysis of Effects and Consequences of SCS Power Failure

The SCS System is required to be equipped with a backup power supply (See SCS specifications in Chapter 2, Appendix 2.C). This ensures uninterrupted operation of the SCS following a power failure. Consequently, a power failure does not affect SCS operation.

Structural

There is no effect on the structural integrity.

Thermal

There is no effect on thermal performance.

Shielding

There is no effect on the shielding performance.

Criticality

There is no effect on the criticality control.

Confinement

There is no effect on the confinement function.

Radiation Protection

As there is no effect on the shielding or confinement functions, there is no effect on occupational or public exposures.

Based on this evaluation, it is concluded that the SCS failure does not affect the safe operation of the HI-STORM 100 System.

11.1.7.4 Corrective Action for SCS Power Failure

The HI-STORM 100 System is designed to withstand a power failure without an adverse effect on its normal operation. Consequently no corrective action is required.

11.1.7.5 Radiological Impact of SCS Power Failure

The event has no radiological impact because the confinement barrier and shielding integrity are not affected.

11.1.8 HI-TRAC Off-Normal Ambient Temperature

As evaluated in Section 4.5 the HI-TRAC is designed to conduct short term operations inside fuel handling building and in the outside environment under design basis ambient temperatures defined in Table 2.2.2. In an event where these temperatures are approached or exceeded an evaluation is required to support operations under greater than design ambient temperatures.

11.1.8.1 Postulated Cause of Off-Normal Ambient Temperatures

The off-normal environmental temperature is postulated as an exceedance of design ambient temperatures caused by extreme weather conditions. To evaluate the effects of off-normal temperatures, it is conservatively assumed that these temperatures persist for a sufficient duration to allow the HI-TRAC temperatures to reach asymptotic steady state conditions. Because of the large mass and thermal inertia of the HI-TRAC and the limited durations for the off-normal temperatures, this assumption is conservative.

11.1.8.2 Detection of Off-Normal Ambient Temperatures

The HI-TRAC is designed with robust margins to withstand off-normal environmental temperatures without challenging short term safety limits. There is no requirement for detection of off-normal environmental temperatures for the HI-TRAC. To address potential exceedance of ambient temperatures at hot sites Appendix B of the HI-STORM Technical Specifications, Section 3.1 requires cask users to evaluate site ambient temperatures.

11.1.8.3 Effects and Consequences of Off-Normal Ambient Temperatures

Structural

There is no effect on the structural performance of the system as a result of this off-normal event.

Thermal

There is no effect on the thermal performance of the system as a result of this off-normal event.

Shielding

There is no effect on the shielding performance of the system as a result of this off-normal event.

Criticality

There is no effect on the criticality control features of the system as a result of this off-normal event.

Confinement

There is no effect on the confinement function of the MPC as a result of this off-normal event.

Radiation Protection

Since there is no degradation in shielding or confinement capabilities as discussed above, there is no effect on occupational or public exposures as a result of this off-normal event.

Based on this evaluation, it is concluded that off-normal environmental temperatures do not affect the safe operation of the HI-TRAC.

11.1.8.4 Corrective Action for Off-Normal Environmental Temperatures

The HI-TRAC is designed with robust margins to withstand off-normal ambient temperatures. No corrective actions are necessary.

11.1.8.5 Radiological Impact of Off-Normal Environmental Temperatures

Off-normal ambient temperatures have no radiological impact, as the confinement barrier and shielding integrity are not affected.

11.2 ACCIDENTS

Accidents, in accordance with ANSI/ANS-57.9, are either infrequent events that could reasonably be expected to occur during the lifetime of the HI-STORM 100 System or events postulated because their consequences may affect the public health and safety. Subsection 2.2.3 defines the design basis accidents considered. By analyzing for these design basis events, safety margins inherently provided in the HI-STORM 100 System design can be quantified.

The results of the evaluations performed herein demonstrate that the HI-STORM 100 System can withstand the effects of all credible and hypothetical accident conditions and natural phenomena without affecting safety function, and are in compliance with the acceptable criteria. The following sections present the evaluation of the design basis postulated accident conditions and natural phenomena which demonstrate that the requirements of 10CFR72.122 are satisfied, and that the corresponding radiation doses satisfy the requirements of 10CFR72.106(b) and 10CFR20.

The load combinations evaluated for postulated accident conditions are defined in Table 2.2.14. The load combinations include normal loads with the accident loads. The accident load combination evaluations are provided in Section 3.4.

11.2.1 HI-TRAC Transfer Cask Handling Accident

11.2.1.1 Cause of HI-TRAC Transfer Cask Handling Accident

During the operation of the HI-STORM 100 System, the loaded HI-TRAC transfer cask is transported to the ISFSI in a vertical position. Unless the lifting device is designed in accordance with the criteria specified in Subsection 2.3.3, the height of the loaded overpack above the ground shall be limited to below the handling height limit determined in Chapter 3 to limit the inertia loading on the cask in a horizontal drop to less than 45g's. Although a handling accident is remote, a cask drop from the horizontal handling height limit is credible only if the lifting device is not designed in accordance with the criteria specified in Subsection 2.3.3. A vertical drop of the loaded HI-TRAC transfer cask is not a credible accident as the loaded HI-TRAC shall be transported and handled in the vertical orientation by devices designed in accordance with the criteria specified in Subsection 2.3.3 and a horizontal drop is precluded as HI-TRAC is transported in the vertical orientation. Nevertheless, for defense-in-depth a drop from a horizontal orientation is postulated and structural consequences evaluated. .

11.2.1.2 HI-TRAC Transfer Cask Handling Accident Analysis

The handling accident analysis evaluates the effects of dropping the loaded HI-TRAC in the horizontal position. The analysis of the handling accident is provided in Chapter 3. The analysis shows that the HI-TRAC meets all structural requirements and there is no adverse effect on the confinement, thermal or subcriticality performance of the contained MPC. Limited localized damage to the HI-TRAC water jacket shell and loss of the water in the water jacket may occur as a result of the handling accident. The HI-TRAC top lid and transfer lid housing (pool lid for the HI-TRAC

HOLTEC INTERNATIONAL COPYRIGHTED MATERIAL

125D) are demonstrated to remain attached by withstanding the maximum deceleration. The transfer lid doors (not applicable to HI-TRAC 125D) are also shown to remain closed during the drop. Limiting the inertia loading to 60g's or less ensures the fuel cladding remains intact based on dynamic impact effects on spent fuel assemblies in the literature [11.2.1]. Therefore, demonstrating that the 45g limit for the HI-TRAC transfer cask is met ensures that the fuel cladding remains intact.

Structural

The structural evaluation of the MPC for 45g's is provided in Section 3.4. As discussed in Section 3.4, the MPC stresses as a result of the HI-TRAC side drop, 45g loading, are all within allowable values.

As discussed above, the water jacket enclosure shell could be punctured which results in a loss of the water within the water jacket. Additionally, the HI-TRAC top lid, transfer lid (pool lid for the HI-TRAC 125D), and transfer lid doors (not applicable to HI-TRAC 125D) are shown to remain in position under the 45g loading. Analysis of the lead in the HI-TRAC is performed in Appendix 3.F and it is shown that there is no appreciable change in the lead shielding.

Thermal

The loss of the water in the water jacket causes the temperatures to increase due to a reduction in the thermal conductivity through the HI-TRAC water jacket. An analysis of the MPC in the HI-TRAC transfer cask temperatures with no water in the water jacket is presented in Subsection 4.6.2. The analysis results are below the short-term allowable fuel cladding and material temperatures limits for accident conditions.

Shielding

The assumed loss of the water in the water jacket results in an increase in the radiation dose rates at locations adjacent to the water jacket. The shielding analysis results presented in Chapter 5 demonstrate that the requirements of 10CFR72.106 are not exceeded. As the structural analysis demonstrates that the HI-TRAC top lid, transfer lid (pool lid for the HI-TRAC 125D), and transfer lid doors (not applicable to HI-TRAC 125D) remain in place, there is no change in the dose rates at the top and bottom of the HI-TRAC.

Criticality

There is no effect on the criticality control features of the system as a result of this accident event.

Confinement

There is no effect on the confinement function of the MPC as a result of this accident event. As discussed in the structural evaluation above, all stresses remain within allowable values, assuring confinement boundary integrity.

Radiation Protection

There is no degradation in the confinement capabilities of the MPC, as discussed above. There are increases in the local dose rates adjacent to the water jacket. The dose rates are provided in Chapter 5. Immediately after the drop accident a radiological inspection of the HI-TRAC will be performed and temporary shielding shall be installed to limit exposure. Based on a minimum distance to the controlled area boundary of 100 meters, the 10CFR72.106 dose rate requirements at the controlled area boundary (5 Rem limit) are not exceeded.

11.2.1.3 HI-TRAC Transfer Cask Handling Accident Dose Calculations

The handling accident could cause localized damage to the HI-TRAC water jacket shell and loss of the water in the water jacket as the neutron shield impacts the ground.

When the water jacket is impacted, the HI-TRAC transfer cask surface dose rate could increase. The HI-TRAC's post-accident shielding analysis presented in Chapter 5 assumes complete loss of the water in the water jacket and bounds the dose rates anticipated for the handling accident.

If the water jacket of the loaded HI-TRAC is damaged beyond immediate repair and the MPC is not damaged, the loaded HI-TRAC may be unloaded into a HI-STORM overpack, a HI-STAR overpack, or unloaded in the fuel pool. If the MPC is damaged, the loaded HI-TRAC must be returned to the fuel pool for unloading. Depending on the damage to the HI-TRAC and the current location in the loading or unloading sequence, personnel exposure is minimized by continuing to load the MPC into a HI-STORM or HI-STAR overpack. Once the MPC is placed in the HI-STORM or HI-STAR overpack, the dose rates are greatly reduced. The highest personnel exposure will result from returning the loaded HI-TRAC to the fuel pool to unload the MPC.

The analysis of the handling accident presented in Section 3.4 shows that the MPC confinement barrier will not be compromised and, therefore, there will be no release of radioactive material from the confinement vessel. Any possible rupture of the fuel cladding will have no effect on the site boundary dose rates because the magnitude of the radiation source has not changed.

11.2.1.4 HI-TRAC Transfer Cask Handling Accident Corrective Action

Following a handling accident, the ISFSI operator shall first perform a radiological and visual inspection to determine the extent of the damage to the HI-TRAC transfer cask and MPC to the maximum practical extent. As appropriate, place temporary shielding around the HI-TRAC to reduce radiation dose rates. Special handling procedures will be developed and approved by the ISFSI operator to lift and upright the HI-TRAC. Upon uprighting, the portion of the overpack not previously accessible shall be radiologically and visually inspected. If damage to the water jacket is limited to a local penetration or crushing, local repairs can be performed to the shell and the water replaced. If damage to the water jacket is extensive, the damage shall be repaired and re-tested in accordance with Chapter 9, following removal of the MPC.

HOLTEC INTERNATIONAL COPYRIGHTED MATERIAL

If upon inspection of the damaged HI-TRAC transfer cask and MPC, damage of the MPC is observed, the loaded HI-TRAC transfer cask will be returned to the facility for fuel unloading in accordance with Chapter 8. The handling accident will not affect the ability to unload the MPC using normal means as the structural analysis of the 60g loading (HI-STAR Docket Numbers 71-9261 and 72-1008) shows that there will be no gross deformation of the MPC basket. After unloading, the structural damage of the HI-TRAC and MPC shall be assessed and a determination shall be made if repairs will enable the equipment to return to service. Subsequent to the repairs, the equipment shall be inspected and appropriate tests shall be performed to certify the equipment for service. If the equipment cannot be repaired and returned to service, the equipment shall be disposed of in accordance with the appropriate regulations.

11.2.2 HI-STORM Overpack Handling Accident

11.2.2.1 Cause of HI-STORM Overpack Handling Accident

During the operation of the HI-STORM 100 System, the loaded HI-STORM overpack is lifted in the vertical orientation. The height of the loaded overpack above the ground shall be limited to below the vertical handling height limit determined in Chapter 3, unless the lifting device is designed in accordance with the criteria specified in Subsection 2.3.3. This vertical handling height limit will maintain the inertial loading on the cask in a vertical drop to 45g's or less. Although a handling accident is remote, a drop from the vertical handling height limit is a credible accident if the lifting device is not designed in accordance with the criteria specified in Subsection 2.3.3.

11.2.2.2 HI-STORM Overpack Handling Accident Analysis

The handling accident analysis evaluates the effects of dropping the loaded overpack in the vertical orientation. The analysis of the handling accident is provided in Chapter 3. The analysis shows that the HI-STORM 100 System meets all structural requirements and there are no adverse effects on the structural, confinement, thermal or subcriticality performance of the HI-STORM 100 System. Limiting the inertia loading to 60g's or less ensures the fuel cladding remains intact based on dynamic impact effects on spent fuel assemblies in the literature [11.2.1].

Structural

The structural evaluation of the MPC under a 60g vertical load is presented in the HI-STAR FSAR and SAR [11.2.3 and 11.2.4] and it is demonstrated therein that the stresses are within allowable limits. The structural analysis of the HI-STORM overpack is presented in Section 3.4. The structural analysis of the overpack shows that the concrete shield attached to the underside of the overpack lid remains attached and air inlet ducts do not collapse.

Thermal

As the structural analysis demonstrates that there is no adverse effect to the MPC or overpack, there is no effect on the thermal performance of the system as a result of this event.

Shielding

As the structural analysis demonstrates that there is no adverse effect to the MPC or overpack, there is no effect on the shielding performance of the system as a result of this event.

Criticality

There is no adverse effect on the criticality control features of the system as a result of this event.

Confinement

There is no adverse effect on the confinement function of the MPC as a result of this event. As discussed in the structural evaluation above, all stresses remain within allowable values, assuring confinement boundary integrity.

Radiation Protection

Since there is no degradation in shielding or confinement capabilities as discussed above, there is no effect on occupational or public exposures as a result of this event.

Based on this evaluation, it is concluded that the vertical drop of the HI-STORM Overpack with the MPC inside does not affect the safe operation of the HI-STORM 100 System.

11.2.2.3 HI-STORM Overpack Handling Accident Dose Calculations

The vertical drop handling accident of the loaded HI-STORM overpack will not cause any change of the shielding or breach of the MPC confinement boundary. Any possible rupture of the fuel cladding will have no effect on the site boundary dose rates because the magnitude of the radiation source has not changed. Therefore, the dose calculations are equivalent to the normal condition dose rates.

11.2.2.4 HI-STORM Overpack Handling Accident Corrective Action

Following a handling accident, the ISFSI operator shall first perform a radiological and visual inspection to determine the extent of the damage to the overpack. Special handling procedures, as required, will be developed and approved by the ISFSI operator.

If upon inspection of the MPC, structural damage of the MPC is observed, the MPC is to be returned to the facility for fuel unloading in accordance with Chapter 8. After unloading, the structural damage of the MPC shall be assessed and a determination shall be made if repairs will enable the

MPC to return to service. Likewise, the HI-STORM overpack shall be thoroughly inspected and a determination shall be made if repairs will enable the HI-STORM overpack to return to service. Subsequent to the repairs, the equipment shall be inspected and appropriate tests shall be performed to certify the HI-STORM 100 System for service. If the equipment cannot be repaired and returned to service, the equipment shall be disposed of in accordance with the appropriate regulations.

11.2.3 Tip-Over

11.2.3.1 Cause of Tip-Over

The analysis of the HI-STORM 100 System has shown that the overpack does not tip over as a result of the accidents (i.e., tornado missiles, flood water velocity, and seismic activity) analyzed in this section. It is highly unlikely that the overpack will tip-over during on-site movement because of the required low handling height or the use of a lifting device designed in accordance with the criteria specified in Subsection 2.3.3. The tip-over accident is stipulated as a non-mechanistic accident.

For the anchored HI-STORM designs (HI-STORM 100A and 100SA), a tip-over accident is not possible. As described in Chapter 2 of this FSAR, these system designs are not evaluated for the hypothetical tip-over. As such, the remainder of this accident discussion applies only to the non-anchored designs (i.e., the 100 and 100S designs only).

11.2.3.2 Tip-Over Analysis

The tip-over accident analysis evaluates the effects of the loaded overpack tipping-over onto a reinforced concrete pad. The tip-over analysis is provided in Section 3.4. The structural analysis provided in Appendix 3.A demonstrates that the resultant deceleration loading on the MPC as a result of the tip-over accident is less than the design basis 45g's. The analysis shows that the HI-STORM 100 System meets all structural requirements and there is no adverse effect on the structural, confinement, thermal, or subcriticality performance of the MPC. However, the side impact will cause some localized damage to the concrete and outer shell of the overpack in the radial area of impact.

Structural

The structural evaluation of the MPC presented in Section 3.4 demonstrates that under a 45g loading the stresses are well within the allowable values. Analysis presented in Chapter 3 shows that the concrete shields attached to the underside and top of the overpack lid remains attached. As a result of the tip-over accident there will be localized crushing of the concrete in the area of impact.

Thermal

The thermal analysis of the overpack and MPC is based on vertical storage. The thermal consequences of this accident while the overpack is in the horizontal orientation are bounded by the burial under debris accident evaluated in Subsection 4.6.2. Damage to the overpack will be limited as

discussed above. As the structural analysis demonstrates that there is no significant change in the MPC or overpack, once the overpack and MPC are returned to their vertical orientation there is no effect on the thermal performance of the system.

Shielding

The effect on the shielding performance of the system as a result of this event is two-fold. First, there may be a localized decrease in the shielding thickness of the concrete in the body of the overpack. Second, the bottom of the overpack, which is normally facing the ground and not accessible, will now be facing the horizon. This orientation will increase the off-site dose rate. However, the dose rate limits of 10CFR72.106 are not exceeded.

Criticality

There is no effect on the criticality control features of the system as a result of this event.

Confinement

There is no effect on the confinement function of the MPC as a result of this event. As discussed in the structural evaluation above, all stresses remain within allowable values, assuring confinement boundary integrity.

Radiation Protection

There is no effect on occupational or public exposures from radionuclide release as a result of this accident event since the confinement boundary integrity of the MPC remains intact.

Immediately after the tip-over accident a radiological inspection of the HI-STORM will be performed and temporary shielding shall be installed to limit exposure from direct radiation. Based on a minimum distance to the controlled area boundary of 100 meters, the 10CFR72.106 dose rate requirements at the controlled area boundary (5 Rem limit) are not exceeded.

Based on this evaluation, it is concluded that the accident does not affect the safe operation of the HI-STORM 100 System.

11.2.3.3 Tip-Over Dose Calculations

The analysis of the tip-over accident has shown that the MPC confinement barrier will not be compromised and, therefore, there will be no release of radioactivity or increase in site-boundary dose rates from release of radioactivity.

The tip-over accident could cause localized damage to the radial concrete shield and outer steel shell where the overpack impacts the surface. The overpack surface dose rate in the affected area could

increase due to the damage. However, there should be no noticeable increase in the ISFSI site or boundary dose rate as a result of the localized damage on the side of the overpack.

The tip-over accident will also cause a re-orientation of the bottom of the overpack. As a result, radiation leaving the bottom of the overpack, which would normally be directed into the ISFSI pad, will be directed towards the horizon and the controlled area boundary. The dose rate at 100 meters from the bottom of the overpack, the minimum distance to the controlled area boundary, was calculated for the HI-STORM 100S Version B with an MPC-24 for an assumed accident duration of 30 days. The burnup and cooling time of the fuel was 60,000 MWD/MTU and 3 years, which is more conservative than consistent with the off-site dose analysis reported in Chapter 10, Table 10.4.1 and the . This combination of overpack, MPC, burnup and cooling time is the same as that used in Chapters 5 and 10 for off-site dose calculations. The results presented below demonstrate that the regulatory requirements of 10CFR72.106 are easily met.

Distance	Dose Rate (mrem/hr)	Accident Duration	Total Dose (mrem)	10CFR72.106 Limit (mrem)
100 meters	2.36	720 hours or 30 days	1699.2	5000

11.2.3.4 Tip-Over Accident Corrective Action

Following a tip-over accident, the ISFSI operator shall first perform a radiological and visual inspection to determine the extent of the damage to the overpack. Special handling procedures, including the use of temporary shielding, will be developed and approved by the ISFSI operator.

If upon inspection of the MPC, structural damage of the MPC is observed, the structural damage shall be assessed and a determination shall be made if repairs will enable the MPC to return to service. If determined necessary, the MPC shall be returned to the facility for fuel unloading or transferred to either a HI-STAR or HI-STORM overpack in accordance with Chapter 8 for a duration that is determined to be appropriate. Likewise, the HI-STORM overpack shall be thoroughly inspected and a determination shall be made if repairs are required and will enable the HI-STORM overpack to return to service. Subsequent to the repairs, the equipment shall be inspected and appropriate tests shall be performed to certify the HI-STORM 100 System for service. If the equipment cannot be repaired and returned to service, the equipment shall be disposed of in accordance with the appropriate regulations.

11.2.4 Fire Accident

11.2.4.1 Cause of Fire

Although the probability of a fire accident affecting a HI-STORM 100 System during storage operations is low, a conservative fire has been assumed and analyzed. The analysis shows that the

HI-STORM 100 System continues to perform its structural, confinement, thermal, and subcriticality functions.

11.2.4.2 Fire Analysis

11.2.4.2.1 Fire Analysis for HI-STORM Overpack

The possibility of a fire accident near an ISFSI is considered to be extremely remote due to an absence of combustible materials within the ISFSI and adjacent to the overpacks. The only credible concern is related to a transport vehicle fuel tank fire, causing the outer layers of the storage overpack to be heated by the incident thermal radiation and forced convection heat fluxes. The amount of combustible fuel in the on-site transporter is limited to a volume of 50 gallons.

Structural

As discussed in Section 3.4, there are no structural consequences as a result of the fire accident condition.

Thermal

Based on a conservative analysis discussed in Subsection 4.6.2, of the HI-STORM 100 System response to a hypothetical fire event, it is concluded that the fire event does not significantly affect the temperature of the MPC or contained fuel. Furthermore, the ability of the HI-STORM 100 System to cool the spent nuclear fuel within temperature limits (Table 2.2.3) during and after fire is not compromised.

Shielding

With respect to concrete damage from a fire, NUREG-1536 (4.0,V,5.b) states: "the loss of a small amount of shielding material is not expected to cause a storage system to exceed the regulatory requirements in 10 CFR 72.106 and, therefore, need not be estimated or evaluated in the SAR." Less than one-inch of the concrete (~4% of the overpack radial concrete thickness) exceeds the short-term temperature limit.

Criticality

There is no effect on the criticality control features of the system as a result of this event.

Confinement

There is no effect on the confinement function of the MPC as a result of this event.

Radiation Protection

HOLTEC INTERNATIONAL COPYRIGHTED MATERIAL

Since there is a much localized reduction in shielding and no effect on the confinement capabilities as discussed above, there is no effect on occupational or public exposures as a result of this accident event.

Based on this evaluation, it is concluded that the overpack fire accident does not affect the safe operation of the HI-STORM 100 System.

11.2.4.2.2 Fire Analysis for HI-TRAC Transfer Cask

To demonstrate the fuel cladding and MPC pressure boundary integrity under an exposure to a hypothetical short duration fire event during on-site handling operations, a fire accident analysis of the loaded 100-ton HI-TRAC is performed. This analysis, because of the lower mass of the 100-ton HI-TRAC, bounds the effects for the 125-ton HI-TRAC.

Structural

As discussed in Section 3.4, there are no adverse structural consequences as a result of the fire accident condition.

Thermal

As discussed in Subsection 4.6.2, the MPC internal pressure and fuel temperature increases as a result of the fire accident. The fire accident MPC internal pressure and peak fuel cladding temperature are substantially less than the accident limits for MPC internal pressure and maximum cladding temperature (Tables 2.2.1 and 2.2.3).

The thermal analysis of the MPC in the HI-TRAC transfer cask under a fire accident is performed in Subsection 4.6.2. As can be concluded from the analysis, the temperatures for fuel cladding and components are below the accident temperature limits.

Shielding

The assumed loss of all the water in the water jacket results in an increase in the radiation dose rates at locations adjacent to the water jacket. The assumed loss of all the Holtite in the 125-ton HI-TRAC lids results in an increase in the radiation dose rates at locations adjacent to the lids. The shielding evaluation presented in Chapter 5 demonstrates that the requirements of 10CFR72.106 are not exceeded.

Criticality

There is no effect on the criticality control features of the system as a result of this event.

Confinement

There is no effect on the confinement function of the MPC as a result of this event, since the internal pressure does not exceed the accident condition design pressure and the MPC confinement boundary temperatures do not exceed the short-term allowable temperature limits.

Radiation Protection

There is no degradation in confinement capabilities of the MPC, as discussed above. Increases in the local dose rates adjacent to the water jacket are evaluated in Chapter 5. . Immediately after the fire accident a radiological inspection of the HI-TRAC shall be performed and temporary shielding shall be installed to limit exposure. .

11.2.4.3 Fire Dose Calculations

The complete loss of the HI-TRAC neutron shield along with the water jacket shell is assumed in the shielding analysis for the post-accident analysis of the loaded HI-TRAC in Chapter 5 and bounds the determined fire accident consequences. The loaded HI-TRAC following a fire accident meets the accident dose rate requirement of 10CFR72.106.

The elevated temperatures experienced by the HI-STORM overpack concrete shield are limited to the outermost layer. Therefore, overall reduction in neutron shielding capabilities is quite small. . The slight increase in the neutron dose rate as a result of the concrete in the outer inch reaching elevated temperatures will not significantly increase the site boundary dose rate, due to the limited amount of the concrete shielding with reduced effectiveness and low site boundary dose rates. The loaded HI-STORM overpack following a fire accident meets the accident dose rate requirement of 10CFR72.106.

The analysis of the fire accident shows that the MPC confinement boundary is not compromised and therefore, there is no release of airborne radioactive materials.

11.2.4.4 Fire Accident Corrective Actions

Upon detection of a fire adjacent to a loaded HI-TRAC or HI-STORM overpack, the ISFSI operator shall take the appropriate immediate actions necessary to extinguish the fire. Fire fighting personnel should take appropriate radiological precautions, particularly with the HI-TRAC as the water jacket pressure relief valves may open with resulting water loss and increase in radiation doses. Following the termination of the fire, a visual and radiological inspection of the equipment shall be performed.

As appropriate, install temporary shielding around the HI-TRAC. Specific attention shall be taken during the inspection of the water jacket of the HI-TRAC. If damage to the HI-TRAC is limited to the loss of water in the water jacket due to the pressure increase, the water may be replaced . If damage to the HI-TRAC water jacket or HI-TRAC body is widespread and/or radiological conditions require, the HI-TRAC shall be unloaded in accordance with Chapter 8, prior to repair.

HOLTEC INTERNATIONAL COPYRIGHTED MATERIAL

If damage to the HI-STORM storage overpack as the result of a fire event is widespread and/or as radiological conditions require, the MPC shall be removed from the HI-STORM overpack in accordance with Chapter 8. However, the thermal analysis described herein demonstrates that only the outermost layer of the radial concrete exceeds its design temperature. The HI-STORM overpack may be returned to service if there is no significant increase in the measured dose rates (i.e., the overpack's shielding effectiveness is confirmed) and if the visual inspection is satisfactory.

11.2.5 Partial Blockage of MPC Basket Vent Holes

Each MPC basket fuel cell wall has elongated vent holes at the bottom and top. The partial blockage of the MPC basket vent holes analyzes the effects on the HI-STORM 100 System due to the restriction of the vent openings.

11.2.5.1 Cause of Partial Blockage of MPC Basket Vent Holes

After the MPC is loaded with spent nuclear fuel, the MPC cavity is drained, dried, and backfilled with helium. There are only two possible sources of material that could block the MPC basket vent holes. These are the fuel cladding/fuel pellets and crud. Due to the maintenance of relatively low cladding temperatures during storage, it is not credible that the fuel cladding would rupture and that fuel cladding and fuel pellets would fall to block the basket vent holes. It is conceivable that a percentage of the crud deposited on the fuel rods may fall off of the fuel assembly and deposit at the bottom of the MPC.

Helium in the MPC cavity provides an inert atmosphere for storage of the fuel. The HI-STORM 100 System maintains the peak fuel cladding temperature below the required long-term storage limits. All credible accidents do not cause the fuel assembly to experience an inertia loading greater than 60g's. Therefore, there is no mechanism for the extensive rupture of spent fuel rod cladding.

Crud can be made up of two types of layers, loosely adherent and tightly adherent. The SNF assembly movement from the fuel racks to the MPC may cause a portion of the loosely adherent crud to fall away. The tightly adherent crud is not removed during ordinary fuel handling operations. The MPC basket vent holes that act as the bottom plenum for the MPC internal thermosiphon are of an elongated, semi-circular design to ensure that the flow passages will remain open under a hypothetical shedding of the crud on the fuel rods. For conservatism, only the minimum semi-circular hole area is credited in the thermal models (i.e., the elongated portion of the hole is completely neglected).

The amount of crud on fuel assemblies varies greatly from plant to plant. Typically, BWR plants have more crud than PWR plants. Based on the maximum expected crud volume per fuel assembly provided in reference [11.2.2], and the area at the base of the MPC basket fuel storage cell, the maximum depth of crud at the bottom of the MPC-68 was determined. For the PWR-style MPC designs, 90% of the maximum crud volume was used to determine the crud depth. The maximum crud depths for each of the MPCs are listed in Table 2.2.8. The maximum amount of crud was

assumed to be present on all fuel assemblies within the MPC. Both the tightly and loosely adherent crud was conservatively assumed to fall off of the fuel assembly. As can be seen by the values listed in the table, the maximum amount of crud depth does not block the MPC basket vent holes as the crud accumulation depth is less than the elongation of the vent holes. Therefore, the available vent holes area is greater than that used in the thermal models.

11.2.5.2 Partial Blockage of MPC Basket Vent Hole Analysis

The partial blockage of the MPC basket vent holes has no effect on the structural, confinement and thermal analysis of the MPC. There is no effect on the shielding analysis other than a slight increase of the gamma radiation dose rate at the base of the MPC due to the accumulation of crud. As the MPC basket vent holes are not completely blocked, preferential flooding of the MPC fuel basket is not possible, and, therefore, the criticality analyses are not affected.

Structural

There are no structural consequences as a result of this event.

Thermal

There is no effect on the thermal performance of the system as a result of this event.

Shielding

There is no effect on the shielding performance of the system as a result of this accident event.

Criticality

There is no effect on the criticality control features of the system as a result of this accident event.

Confinement

There is no effect on the confinement function of the MPC as a result of this accident event.

Radiation Protection

Since there is no degradation in shielding or confinement capabilities as discussed above, there is no effect on occupational or public exposures as a result of this accident event.

Based on this evaluation, it is concluded that the partial blockage of MPC vent holes does not affect the safe operation of the HI-STORM 100 System.

11.2.5.3 Partial Blockage of MPC Basket Vent Holes Dose Calculations

Partial blockage of basket vent holes will not result in a compromise of the confinement boundary. Therefore, there will be no effect on the site boundary dose rates because the magnitude of the radiation source has not changed. There will be no radioactive material release.

11.2.5.4 Partial Blockage of MPC Basket Vent Holes Corrective Action

There are no consequences that exceed normal storage conditions. No corrective action is required for the partial blockage of the MPC basket vent holes.

11.2.6 Tornado

11.2.6.1 Cause of Tornado

The HI-STORM 100 System will be stored on an unsheltered ISFSI concrete pad and subject to environmental conditions. Additionally, the transfer of the MPC from the HI-TRAC transfer cask to the overpack may be performed at the unsheltered ISFSI concrete pad. It is possible that the HI-STORM System (storage overpack and HI-TRAC transfer cask) may experience the extreme environmental conditions of a tornado.

11.2.6.2 Tornado Analysis

The tornado accident has two effects on the HI-STORM 100 System. The tornado winds and/or tornado missile attempt to tip-over the loaded overpack or HI-TRAC transfer cask. The pressure loading of the high velocity winds and/or the impact of the large tornado missiles act to apply an overturning moment. The second effect is tornado missiles propelled by high velocity winds, which attempt to penetrate the storage overpack or HI-TRAC transfer cask.

During handling operations at the ISFSI pad, the loaded HI-TRAC transfer cask, while in the vertical orientation, shall be attached to a lifting device designed in accordance with the requirements specified in Subsection 2.3.3. Therefore, it is not credible that the tornado missile and/or wind could tip-over the loaded HI-TRAC while being handled in the vertical orientation. During handling of the loaded HI-TRAC in the horizontal orientation, it is possible that the tornado missile and/or wind may cause the rollover of the loaded HI-TRAC on the transport vehicle unless the lifting device is designed in accordance with the requirements specified in Subsection 2.3.3. The horizontal drop handling accident for the loaded HI-TRAC, Subsection 11.2.1, evaluates the consequences of the loaded HI-TRAC falling from the horizontal handling height limit and consequently this bounds the effect of the roll-over of the loaded HI-TRAC on the transport vehicle.

Structural

Section 3.4 provides the analysis of the pressure loading which attempts to tip-over the storage overpack and the analysis of the effects of the different types of tornado missiles. These analyses

HOLTEC INTERNATIONAL COPYRIGHTED MATERIAL

HI-STORM 100 FSAR

REPORT HI-2002444

HI-STORM 100 FSAR, NON-PROPRIETARY

REVISION 12

MARCH 12, 2014

11.2-14

Rev. 11

show that the loaded storage overpack does not tip-over as a result of the tornado winds and/or tornado missiles.

Analyses provided in Section 3.4 also shows that the tornado missiles do not penetrate the storage overpack or HI-TRAC transfer cask to impact the MPC. The result of the tornado missile impact on the storage overpack or HI-TRAC transfer cask is limited to damage of the shielding.

Thermal

The thermal consequences are evaluated in Subsection 11.2.1.

Shielding

The loss of the water in the water jacket results in an increase in the radiation dose rates at locations adjacent to the water jacket. The shielding analysis results presented in Chapter 5 demonstrate that the requirements of 10CFR72.106 are not exceeded.

Criticality

There is no effect on the criticality control features of the system as a result of this event.

Confinement

There is no effect on the confinement function of the MPC as a result of this event.

Radiation Protection

There is no degradation in confinement capabilities of the MPC, since the tornado missiles do not impact the MPC, as discussed above. Increases in the local dose rates as a result of the loss of water in the HI-TRAC water jacket are evaluated in Chapter 5. Immediately after the tornado accident a radiological inspection of the HI-TRAC shall be performed and temporary shielding shall be installed to limit the exposure to the public.

11.2.6.3 Tornado Dose Calculations

The tornado winds do not tip-over the loaded storage overpack; damage the shielding materials of the overpack or HI-TRAC; or damage the MPC confinement boundary. There is no affect on the radiation dose as a result of the tornado winds. A tornado missile may cause localized damage in the concrete radial shielding of the storage overpack. However, the damage will have a negligible effect on the site boundary dose. A tornado missile may penetrate the HI-TRAC water jacket shell causing the loss of the neutron shielding (water). The effects of the tornado missile damage on the loaded HI-TRAC transfer cask is bounded by the post-accident dose assessment performed in Chapter 5, which conservatively assumes complete loss of the water in the water jacket and the water jacket shell.

11.2.6.4 Tornado Accident Corrective Action

Following exposure of the HI-STORM 100 System to a tornado, the ISFSI operator shall perform a visual and radiological inspection of the overpack and/or HI-TRAC transfer cask. Damage sustained by the overpack outer shell, concrete, or vent screens shall be inspected and repaired. Damage sustained by the HI-TRAC shall be inspected and repaired.

11.2.7 Flood

11.2.7.1 Cause of Flood

The HI-STORM 100 System will be located on an unsheltered ISFSI concrete pad. Therefore, it is possible for the storage area to be flooded. The potential sources for the flood water could be unusually high water from a river or stream, a dam break, a seismic event, or a hurricane.

11.2.7.2 Flood Analysis

Structural

The flood accident affects the HI-STORM 100 overpack structural analysis in two ways. The flood water velocity acts to apply an overturning moment, which attempts to tip-over the loaded overpack. The flood affects the MPC by applying an external pressure.

Section 3.4 provides the analysis of the flood water applying an overturning moment. The results of the analysis show that the loaded overpack does not tip over if the flood velocity does not exceed the value stated in Table 2.2.8.

The structural evaluation of the MPC for the accident condition external pressure (Table 2.2.1) is presented in Section 3.4 and the resulting stresses from this event are shown to be well within the allowable values.

Thermal

For a flood of sufficient magnitude to allow the water to come into contact with the MPC, there is no adverse effect on the thermal performance of the system. The thermal consequence of such a flood is an increase in the rejection of the decay heat. Because the storage overpack is ventilated, water from a large flood will enter the annulus between the MPC and the overpack. The water would provide cooling that exceeds that available in the air filled annulus, due to water's higher thermal conductivity.

A smart flood condition that blocks the air flow but is not sufficient to allow water to come into contact with the MPC is bounded by the 100% inlet ducts blocked condition evaluated in Subsection 11.2.13.

Shielding

There is no effect on the shielding performance of the system as a result of this event. The flood water provides additional shielding that reduces radiation doses.

Criticality

There is no effect on the criticality control features of the system as a result of this event. The criticality analysis is unaffected because under the flooding condition water does not enter the MPC cavity and therefore the reactivity would be less than the loading condition in the fuel pool, which is presented in Section 6.1.

Confinement

There is no effect on the confinement function of the MPC as a result of this event. As discussed in the structural evaluation above, all stresses remain within allowable values, assuring confinement boundary integrity.

Radiation Protection

Since there is no degradation in shielding or confinement capabilities as discussed above, there is no effect on occupational or public exposures as a result of this event.

Based on this evaluation, it is concluded that the flood accident does not affect the safe operation of the HI-STORM 100 System.

11.2.7.3 Flood Dose Calculations

Since the flood accident produces no leakage of radioactive material and no reduction in shielding effectiveness, there are no adverse radiological consequences.

11.2.7.4 Flood Accident Corrective Action

As shown in the analysis of the flood accident, the HI-STORM 100 System sustains no damage as a result of the flood. At the completion of the flood, exposed surfaces may need debris and adherent foreign matter removal.

11.2.8 Earthquake

11.2.8.1 Cause of Earthquake

The HI-STORM 100 System may be employed at any reactor or ISFSI facility in the United States. It is possible that during the use of the HI-STORM 100 System, the ISFSI may experience an earthquake.

HOLTEC INTERNATIONAL COPYRIGHTED MATERIAL

11.2.8.2 Earthquake Analysis

The earthquake accident analysis evaluates the effects of a seismic event on the loaded HI-STORM 100 System. The objective is to determine the stability limits of the HI-STORM 100 System. Based on a static stability criteria, it is shown in Chapter 3 that the HI-STORM 100 System is qualified to seismic activity less than or equal to the values specified in Table 2.2.8. The analyses in Chapter 3 show that the HI-STORM 100 System will not tip over under the conditions evaluated. The seismic activity has no adverse thermal, criticality, confinement, or shielding consequences.

Some ISFSI sites will have earthquakes that exceed the seismic activity specified in Table 2.2.8. For these high-seismic sites, anchored HI-STORM designs (the HI-STORM 100A and 100SA) have been developed. The design of these anchored systems is such that seismic loads cannot result in tip-over or lateral displacement. Chapter 3 provides a detailed discussion of the anchored systems design.

Structural

The sole structural effect of the earthquake is an inertial loading of less than 1g. This loading is bounded by the tip-over analysis presented in Subsection 11.2.3, which analyzes a deceleration of 45g's and demonstrates that the MPC allowable stress criteria are met.

Thermal

There is no effect on the thermal performance of the system as a result of this event.

Shielding

There is no effect on the shielding performance of the system as a result of this event.

Criticality

There is no effect on the criticality control features of the system as a result of this event.

Confinement

There is no effect on the confinement function of the MPC as a result of this event.

Radiation Protection

Since there is no degradation in shielding or confinement capabilities as discussed above, there is no effect on occupational or public exposures as a result of this event.

Based on this evaluation, it is concluded that the earthquake does not affect the safe operation of the HI-STORM 100 System.

HOLTEC INTERNATIONAL COPYRIGHTED MATERIAL

11.2.8.3 Earthquake Dose Calculations

Structural analysis of the earthquake accident shows that the loaded overpack will not tip over as a result of the specified seismic activity. If the overpack were to tip over, the resultant damage would be equal to that experienced by the tip-over accident analyzed in Subsection 11.2.3. Since the loaded overpack does not tip-over, there is no increase in radiation dose rates or release of radioactivity.

11.2.8.4 Earthquake Accident Corrective Action

Following the earthquake accident, the ISFSI operator shall perform a visual and radiological inspection of the overpacks in storage to determine if any of the overpacks have tipped-over. In the unlikely event of a tip-over, the corrective actions shall be in accordance with Subsection 11.2.3.4.

11.2.9 100% Fuel Rod Rupture

This accident event postulates that all the fuel rods rupture and that the appropriate quantities of fission product gases and fill gas are released from the fuel rods into the MPC cavity.

11.2.9.1 Cause of 100% Fuel Rod Rupture

Through all credible accident conditions, the HI-STORM 100 System maintains the spent nuclear fuel in an inert environment while maintaining the peak fuel cladding temperature below the required short-term temperature limits, thereby providing assurance of fuel cladding integrity. There is no credible cause for 100% fuel rod rupture. This accident is postulated to evaluate the MPC confinement barrier for the maximum possible internal pressure based on the non-mechanistic failure of 100% of the fuel rods.

11.2.9.2 100% Fuel Rod Rupture Analysis

The 100% fuel rod rupture accident has no thermal, structural, criticality or shielding consequences. The event does not change the reactivity of the stored fuel, the magnitude of the radiation source, which is being shielded, the shielding capability, or the criticality control features of the HI-STORM 100 System. The determination of the maximum accident pressure is provided in Chapter 4. The MPC design basis internal pressure bounds the pressure developed assuming 100% fuel rod rupture. The structural analysis provided in Chapter 3 evaluates the MPC confinement boundary under the accident condition design internal pressure.

Structural

The structural evaluation of the MPC for the accident condition internal pressure presented in Section 3.4 demonstrates that the MPC stresses are well within the allowable values.

Thermal

The MPC internal pressure for the 100% fuel rod rupture condition is presented in Table 4.4.9. As can be seen from the values, the design basis accident condition MPC internal pressure (Table 2.2.1) used in the structural evaluation bounds the calculated value.

Shielding

There is no effect on the shielding performance of the system as a result of this event.

Criticality

There is no effect on the criticality control features of the system as a result of this event.

Confinement

There is no effect on the confinement function of the MPC as a result of this event. As discussed in the structural evaluation above, all stresses remain within allowable values, assuring confinement boundary integrity.

Radiation Protection

Since there is no degradation in shielding or confinement capabilities as discussed above, there is no effect on occupational or public exposures as a result of this event.

Based on this evaluation, it is concluded that the non-mechanistic 100% fuel rod rupture accident does not affect the safe operation of the HI-STORM 100 System.

11.2.9.3 100% Fuel Rod Rupture Dose Calculations

The MPC confinement boundary maintains its integrity. There is no effect on the shielding effectiveness, and the magnitude of the radiation source is unchanged. However, the radiation source could redistribute within the sealed MPC cavity causing a slight change in the radiation dose rates at certain locations. Therefore, there is no release of radioactive material or significant increase in radiation dose rates.

11.2.9.4 100% Fuel Rod Rupture Accident Corrective Action

As shown in the analysis of the 100% fuel rod rupture accident, the MPC confinement boundary is not damaged. The HI-STORM 100 System is designed to withstand this accident and continue performing the safe storage of spent nuclear fuel under normal storage conditions. No corrective actions are required.

11.2.10 Confinement Boundary Leakage

The MPC uses redundant confinement closures to assure that there is no release of radioactive materials for postulated storage accident conditions. The analyses presented in Chapter 3 and this chapter demonstrate that the MPC remains intact during all postulated accident conditions. The discussion contained in Chapter 7 demonstrates that MPC is designed, welded, tested and inspected to meet the guidance of ISG-18 such that leakage from the confinement boundary is considered non-credible.

11.2.10.1 Cause of Confinement Boundary Leakage

There is no credible cause for confinement boundary leakage. The accidents analyzed in this chapter show that the MPC confinement boundary withstands all credible accidents. There are no man-made or natural phenomena that could cause failure of the confinement boundary restricting radioactive material release. Additionally, because the MPC satisfies the criteria specified in Interim Staff Guidance (ISG) 18, there is no credible leakage that would occur from the confinement boundary.

11.2.10.2 Confinement Boundary Leakage Accident Corrective Action

The HI-STORM 100 System is designed to withstand this accident and continue performing the safe storage of spent nuclear fuel. No corrective actions are required.

11.2.11 Explosion

11.2.11.1 Cause of Explosion

An explosion within the bounds of an ISFSI is improbable since there are no explosive materials within the site boundary. An explosion as a result of combustion of the fuel contained in cask transport vehicle is possible. As the fuel available for the explosion is limited in quantity the effects of an explosion on a reinforced structure are minimal. Explosions postulated to occur within or beyond the ISFSI boundary would require a site hazards evaluation under the provisions of 72.212 regulations by individual cask users.

11.2.11.2 Explosion Analysis

Any credible explosion accident is bounded by the accident external design pressure (Table 2.2.1) analyzed as a result of the flood accident water depth in Subsection 11.2.7 and the tornado missile accident of Subsection 11.2.6, because explosive materials are not stored within close proximity to the casks. The bounding analysis shows that the MPC and the Overpack can withstand the effects of substantial accident external pressures without collapse or rupture.

Structural

The structural evaluations for the MPC accident condition external pressure and overpack pressure differential are presented in Section 3.4 and demonstrate that all stresses are within allowable values.

Thermal

There is no effect on the thermal performance of the system as a result of this event.

Shielding

There is no effect on the shielding performance of the system as a result of this event.

Criticality

There is no effect on the criticality control features of the system as a result of this event.

Confinement

There is no effect on the confinement function of the MPC as a result of this event. As discussed in the structural evaluation above, all stresses remain within allowable values, assuring confinement boundary integrity.

Radiation Protection

Since there is no degradation in shielding or confinement capabilities as discussed above, there is no effect on occupational or public exposures as a result of this event.

Based on this evaluation, it is concluded that the explosion accident does not affect the safe operation of the HI-STORM 100 System.

11.2.11.3 Explosion Dose Calculations

The bounding external pressure load has no effect on the HI-STORM 100 overpack and MPC. Therefore, no effect on the shielding, criticality, thermal or confinement capabilities of the HI-STORM 100 System is experienced as a result of the explosion pressure load. The effects of explosion generated missiles on the HI-STORM 100 System structure is bounded by the analysis of tornado generated missiles.

11.2.11.4 Explosion Accident Corrective Action

The explosive overpressure caused by the explosion is bounded by the external pressure exerted by the flood accident. The external pressure from the flood is shown not to damage the HI-STORM 100 System. Following an explosion, the ISFSI operator shall perform a visual and radiological

inspection of the overpack. If the outer shell or concrete is damaged as a result of explosion generated missiles, the concrete material may be replaced and the outer shell repaired.

11.2.12 Lightning

11.2.12.1 Cause of Lightning

The HI-STORM 100 System will be stored on an unsheltered ISFSI concrete pad. There is the potential for lightning to strike the overpack. This analysis evaluates the effects of lightning striking the overpack.

11.2.12.2 Lightning Analysis

The HI-STORM 100 System is a large metal/concrete cask stored in an unsheltered ISFSI. As such, it may be subject to lightning strikes. When the HI-STORM 100 System is hit with lightning, the lightning will discharge through the steel shell of the overpack to the ground. Lightning strikes have high currents, but their duration is short (i.e., less than a second). The overpack outer shell is composed of conductive carbon steel and, as such, will provide a direct path to ground.

The MPC provides the confinement boundary for the spent nuclear fuel. The effects of a lightning strike will be limited to the overpack. The lightning current will discharge into the overpack and directly into the ground. Therefore, the MPC will be unaffected.

Structural

There is no structural consequence as a result of this event.

Thermal

There is no effect on the thermal performance of the system as a result of this event.

Shielding

There is no effect on the shielding performance of the system as a result of this event.

Criticality

There is no effect on the criticality control features of the system as a result of this event.

Confinement

There is no effect on the confinement function of the MPC as a result of this event.

Radiation Protection

Since there is no degradation in shielding or confinement capabilities as discussed above, there is no effect on occupational or public exposures as a result of this event.

Based on this evaluation, it is concluded that the lightning accident does not affect the safe operation of the HI-STORM 100 System.

11.2.12.3 Lightning Dose Calculations

An evaluation of lightning strikes demonstrates that the effect of a lightning strike has no effect on the confinement boundary or shielding materials. Therefore, no further analysis is necessary.

11.2.12.4 Lightning Accident Corrective Action

The HI-STORM 100 System will not sustain any damage from the lightning accident. There is no surveillance or corrective action required.

11.2.13 100% Blockage of Air Inlets

11.2.13.1 Cause of 100% Blockage of Air Inlets

This event is defined as a complete blockage of all four bottom inlets. Such blockage of the inlets may be postulated to occur as a result of a flood, blizzard snow accumulation, tornado debris, or volcanic activity.

11.2.13.2 100% Blockage of Air Inlets Analysis

The immediate consequence of a complete blockage of the air inlet ducts is that the normal circulation of air for cooling the MPC is stopped. An amount of heat will continue to be removed by localized air circulation patterns in the overpack annulus and outlet ducts, and the MPC will continue to radiate heat to the relatively cooler storage overpack. As the temperatures of the MPC and its contents rise, the rate of heat rejection will increase correspondingly. Under this condition, the temperatures of the overpack, the MPC and the stored fuel assemblies will rise as a function of time.

As a result of the large mass, and correspondingly large thermal capacity of the storage overpack, it is expected that a significant temperature rise is only possible if the blocked condition is allowed to persist for a number of days. This accident condition is, however, a short duration event that will be identified and corrected by scheduled periodic surveillance at the ISFSI site.

Structural

There are no structural consequences as a result of this event.

Thermal

A thermal analysis is performed in Subsection 4.6.2 to determine the effect of a complete blockage of all inlets for an extended duration. For this event, both the fuel cladding and component temperatures remain below their short-term temperature limits. The MPC internal pressure for this event is evaluated in Subsection 4.6.2 and is bounded by the design basis internal pressure for accident conditions (Table 2.2.1).

Shielding

There is no effect on the shielding performance of the system as a result of this event, since the concrete temperatures do not exceed the short-term condition design temperature provided in Table 2.2.3.

Criticality

There is no effect on the criticality control features of the system as a result of this event.

Confinement

There is no effect on the confinement function of the MPC as a result of this event.

Radiation Protection

Since there is no degradation in shielding or confinement capabilities as discussed above, there is no effect on occupational or public exposures as a result of this event.

Based on this evaluation, it is concluded that the 100% blockage of air inlets accident does not affect the safe operation of the HI-STORM 100 System, if the blockage is removed in the specified time period.

11.2.13.3 100% Blockage of Air Inlets Dose Calculations

As shown in the analysis of the 100% blockage of air inlets accident, the shielding capabilities of the HI-STORM 100 System are unchanged because the peak concrete temperature does not exceed its short-term condition design temperature. The elevated temperatures will not cause the breach of the confinement system and the short term fuel cladding temperature limit is not exceeded. Therefore, there is no radiological impact.

11.2.13.4 100% Blockage of Air Inlets Accident Corrective Action

Analysis of the 100% blockage of air inlet accident shows that the temperatures for cask system components and fuel cladding are within the accident temperature limits if the blockage is cleared within 32 hours. Upon detection of the complete blockage of the air inlet ducts, the ISFSI operator

shall assign personnel to clear the blockage with mechanical and manual means as necessary. After clearing the overpack ducts, the overpack shall be visually and radiologically inspected for any damage. If exit air temperature monitoring is performed in lieu of direct visual inspections, the difference between the ambient air temperature and the exit air temperature will be the basis for assurance that the temperature limits are not exceeded.

For an accident event that completely blocks the inlet or outlet air ducts for greater than the analyzed duration, a site-specific evaluation or analysis may be performed to demonstrate adequate heat removal for the duration of the event. Adequate heat removal is defined as the minimum rate of heat dissipation that ensures cladding temperatures limits are met and structural integrity of the MPC and Overpack is not compromised. For those events where an evaluation or analysis is not performed or is not successful in showing that cladding temperatures remain below their short term temperature limits, the site's emergency plan shall include provisions to address removal of the material blocking the air inlet ducts and to provide alternate means of cooling prior to exceeding the time when the fuel cladding temperature reaches its short-term temperature limit. Alternate means of cooling could include, for example, spraying water into the air outlet ducts using pumps or fire-hoses or blowing air into the air outlet ducts using fans, to directly cool the MPC.

11.2.14 Burial Under Debris

11.2.14.1 Cause of Burial Under Debris

Burial of the HI-STORM System under debris is not a credible accident. During storage at the ISFSI, there are no structures over the casks. The minimum regulatory distance(s) from the ISFSI to the nearest site boundary and the controlled area around the ISFSI concrete pad precludes the close proximity of substantial amounts of vegetation.

There is no credible mechanism for the HI-STORM System to become completely buried under debris. However, for conservatism, complete burial under debris is considered. Blockage of the HI-STORM overpack air inlet ducts has already been considered in Subsection 11.2.13.

11.2.14.2 Burial Under Debris Analysis

Burial of the HI-STORM System does not impose a condition that would have more severe consequences for criticality, confinement, shielding, and structural analyses than that performed for the other accidents analyzed. The debris would provide additional shielding to reduce radiation doses. The accident external pressure encountered during the flood bounds any credible pressure loading caused by the burial under debris.

Burial under debris can affect thermal performance because the debris acts as an insulator and heat sink. This will cause the HI-STORM System and fuel cladding temperatures to increase. A thermal analysis has been performed to determine the time for the fuel cladding temperatures to reach the short term accident condition temperature limit during a burial under debris accident.

Structural

The structural evaluation of the MPC enclosure vessel for accident internal pressure conditions bounds the pressure calculated herein. Therefore, the resulting stresses from this event are well within the allowable values, as demonstrated in Section 3.4.

Thermal

The fuel cladding and MPC integrity is evaluated in Subsection 4.6.2. The evaluation demonstrates that the fuel cladding and confinement function of the MPC are not compromised.

Shielding

There is no effect on the shielding performance of the system as a result of this event.

Criticality

There is no effect on the criticality control features of the system as a result of this event.

Confinement

There is no effect on the confinement function of the MPC as a result of this event. As discussed in the structural evaluation above, all stresses remain within allowable values, assuring confinement boundary integrity.

Radiation Protection

Since there is no degradation in shielding or confinement capabilities as discussed above, there is no effect on occupational or public exposures as a result of this event.

Based on this evaluation, it is concluded that the burial under debris accident does not affect the safe operation of the HI-STORM 100 System, if the debris is removed within the specified time. The 24-hour minimum duct inspection interval ensures that a burial under debris condition will be detected long before the allowable burial time is reached.

11.2.14.3 Burial Under Debris Dose Calculations

As discussed in burial under debris analysis, the shielding is enhanced while the HI-STORM System is covered.

The elevated temperatures will not cause the breach of the confinement system and the short term fuel cladding temperature limit is not exceeded. Therefore, there is no radiological impact.

11.2.14.4 Burial Under Debris Accident Corrective Action

Analysis of the burial under debris accident shows that the fuel cladding peak temperatures are not exceeded even for an extended duration of burial. Upon detection of the burial under debris accident, the ISFSI operator shall assign personnel to remove the debris with mechanical and manual means as necessary. After uncovering the storage overpack, the storage overpack shall be visually and radiologically inspected for any damage. The loaded MPC shall be removed from the storage overpack with the HI-TRAC transfer cask to allow complete inspection of the overpack air inlets and outlets, and annulus. Removal of obstructions to the air flow path shall be performed prior to the re-insertion of the MPC. The site's emergency action plan shall include provisions for the performance of this corrective action.

11.2.15 Extreme Environmental Temperature

11.2.15.1 Cause of Extreme Environmental Temperature

The extreme environmental temperature is postulated as a constant ambient temperature caused by extreme weather conditions. To determine the effects of the extreme temperature, it is conservatively assumed that the temperature persists for a sufficient duration to allow the HI-STORM 100 System to achieve thermal equilibrium. Because of the large mass of the HI-STORM 100 System, with its corresponding large thermal inertia and the limited duration for the extreme temperature, this assumption is conservative.

11.2.15.2 Extreme Environmental Temperature Analysis

The accident condition considering an extreme environmental temperature (Table 2.2.2) for a duration sufficient to reach thermal equilibrium is evaluated with respect to accident condition design temperatures listed in Table 2.2.3.

Structural

The structural evaluation of the MPC enclosure vessel for accident condition internal pressure bounds the pressure resulting from this event. Therefore, the resulting stresses from this event are bounded by that of the accident condition and are well within the allowable values, as discussed in Section 3.4.

Thermal

The resulting temperatures for the system and fuel assembly cladding are provided in evaluation performed in Subsection 4.6.2. As concluded from this evaluation, all temperatures are within the short-term accident condition allowable values specified in Table 2.2.3.

Shielding

There is no effect on the shielding performance of the system as a result of this event, since the concrete temperature does not exceed the short-term temperature limit specified in Table 2.2.3.

Criticality

There is no effect on the criticality control features of the system as a result of this event.

Confinement

There is no effect on the confinement function of the MPC as a result of this event. As discussed in the structural evaluation above, all stresses remain within allowable values, assuring confinement boundary integrity.

Radiation Protection

Since there is no degradation in shielding or confinement capabilities as discussed above, there is no effect on occupational or public exposures as a result of this event.

Based on this evaluation, it is concluded that the extreme environment temperature accident does not affect the safe operation of the HI-STORM 100 System.

11.2.15.3 Extreme Environmental Temperature Dose Calculations

The extreme environmental temperature will not cause the concrete to exceed its normal design temperature. Therefore, there will be no degradation of the concrete's shielding effectiveness. The elevated temperatures will not cause a breach of the confinement system and the short-term fuel cladding temperature is not exceeded. Therefore, there is no radiological impact on the HI-STORM 100 System for the extreme environmental temperature and the dose calculations are equivalent to the normal condition dose rates.

11.2.15.4 Extreme Environmental Temperature Corrective Action

There are no consequences of this accident that require corrective action.

11.2.16 Supplemental Cooling System (SCS) Failure

The SCS system is a forced fluid circulation device used to provide supplemental HI-TRAC cooling. For fluid circulation, the SCS system is equipped with active components requiring power for normal operation. Although an SCS System failure is highly unlikely, for defense-in-depth an accident condition that renders it inoperable for an extended duration is postulated herein.

11.2.16.1 Cause of SCS Failure

Possible causes of SCS failure are: (a) Simultaneous loss of external and backup power, or (b) Complete loss of annulus water from an uncontrolled leak or line break.

11.2.16.2 Analysis of Effects and Consequences of SCS Failure

Structural

See discussion under thermal evaluation below.

Thermal

In the event of a SCS failure due to (a), the following sequence of events occur:

- i) The annulus water temperature rises to reach its boiling temperature (~212°F).
- ii) A progressive reduction of water level and dryout of the annulus.

In the event of an SCS failure due to (b), a rapid water loss occurs and annulus is replaced with air. This condition is evaluated in Section 4.5.5.3.

Shielding

There is no adverse effect on the shielding effectiveness of the system.

Criticality

There is no adverse effect on the criticality control of the system.

Confinement

There is no adverse effect on the confinement function of the MPC. As discussed in the evaluations above, the structural boundary pressures are within design limits.

Radiation Protection

As there is no adverse effect on the shielding or confinement functions, there is no effect on occupational or public exposures as a result of this off-normal event.

Based on this evaluation, it is concluded that the SCS failure does not affect the safe operation of the HI-STORM 100 System.

11.2.16.3 SCS Failure Dose Calculations

The event has no radiological impact because the confinement barrier and shielding integrity are not affected.

11.2.16.4 SCS Failure Corrective Action

In the vertical orientation the HI-TRAC is designed to withstand an SCS failure without an adverse effect on its safety functions.

11.3 REFERENCES

- [11.2.1] Chun et al., “Dynamic Impact Effects on Spent Fuel Assemblies,” Lawrence Livermore National Laboratory, UCID-21246, (October 1987).
- [11.2.2] ESEERCO Project EP91-29 and EPRI Project 3100-02, “Debris Collection System for Boiling Water Reactor Consolidation Equipment,” B&W Fuel Company, (October 1995).
- [11.2.3] Docket Number 72-1008, HI-STAR 100 System FSAR, Holtec Report HI-2012610, Revision 2.
- [11.2.4] Docket Number 71-9261, HI-STAR 100 System SAR, Holtec Report HI-951251, Revision 10.

SUPPLEMENT 11.I

ACCIDENT EVALUATION FOR THE HI-STORM 100U SYSTEM

11.I.0 INTRODUCTION

This supplement is focused on the off-normal and accident condition evaluations of the HI-STORM 100U vertical ventilated module (VVM). Only those events that are actually affected by the design of the overpack are discussed in detail herein. The reader is referred to the main body of Chapter 11 for discussions of any off-normal or accident conditions that are not dependent on the design of the storage overpack (i.e., MPC-only or HI-TRAC events).

The evaluations described herein parallel those of the HI-STORM 100 overpack contained in the main body of Chapter 11 of this FSAR. To ensure readability, the sections in this supplement are numbered to be directly analogous to the sections in the main body of the chapter. For example, the fire accident evaluation presented in Supplement Subsection 11.I.2.4 for the HI-STORM 100U is analogous to the evaluation presented in Subsection 11.2.4 of the main body of Chapter 11 for the HI-STORM 100. Tables and figures (if any) in this supplement, however, are labeled sequentially by section. If there is an analogous table or figure in the main body of Chapter 11, an appropriate notation is made in the supplement table or figure.

11.I.1 OFF-NORMAL EVENTS

A general discussion of off-normal events is presented in Section 11.1 of the main body of Chapter 11. The following off-normal events are discussed in this supplement:

- Off-Normal Pressure
- Off-Normal Environmental Temperature
- Leakage of One MPC Seal Weld
- Partial Blockage of Air Inlets
- Off-Normal Handling of HI-TRAC Transfer Cask
- Malfunction of FHD System
- SCS Power Failure
- Off-Normal Wind
- HI-TRAC Off-Normal Ambient Temperature

The results of the evaluations presented herein demonstrate that the HI-STORM 100U System can withstand the effects of off-normal events without affecting its ability to perform its intended function, and is in compliance with the applicable acceptance criteria.

11.I.1.1 Off-Normal Pressure

A discussion of this off-normal condition is presented in Subsection 11.1.1 of the main body of Chapter 11. A description of the cause of, detection of, corrective actions for and radiological impact of this event is presented therein.

HOLTEC INTERNATIONAL COPYRIGHTED MATERIAL

Structural

The structural evaluation of the MPC enclosure vessel for off-normal internal pressure conditions is discussed in Section 3.4. The applicable pressure boundary stress limits are confirmed to bound the stresses resulting from the off-normal pressure.

Thermal

In 4.6.1 the MPC internal pressure under the conditions of 10% fuel rods ruptured, insolation and a limiting fuel storage configuration in an aboveground overpack is evaluated. This evaluation is bounding as the MPC temperatures in the 100U overpack are bounded by the aboveground overpack.

Shielding

There is no effect on the shielding performance of the system as a result of this off-normal event.

Criticality

There is no effect on the criticality control features of the system as a result of this off-normal event.

Confinement

There is no effect on the confinement function of the MPC as a result of this off-normal event. As discussed in the structural evaluation mentioned above, all stresses remain within allowable values, assuring confinement boundary integrity.

Radiation Protection

Since there is no degradation in shielding or confinement capabilities as discussed above, there is no effect on occupational or public exposures as a result of this off-normal event.

Based on this evaluation, it is concluded that the off-normal pressure does not affect the safe operation of the HI-STORM 100U System.

11.1.1.2 Off-Normal Environmental Temperatures

A discussion of this off-normal condition is presented in Subsection 11.1.2 of the main body of Chapter 11. A description of the cause of, detection of, corrective actions for and radiological impact of this event is presented therein.

Structural

The effect on the MPC for the upper off-normal thermal conditions (i.e., 100°F) is an increase in the internal pressure. However, as shown previously the resultant pressure is below the off-normal design pressure (Table 2.2.1). The effect of the lower off-normal thermal conditions (i.e., -40°F) requires an evaluation of the potential for brittle fracture. Such an evaluation is presented in Subsections 3.1.2 and 3.1.1.

Thermal

Supplement 4.I calculates bounding temperatures and pressures for the HI-STORM 100U under the elevated temperature condition. The calculated temperatures and pressures are reported in Table 4.I.5 and are below the off-normal limits (Tables 2.2.3, 2.1.8 and 2.2.1).

The off-normal event considering an environmental temperature of -40°F and no solar insolation for a duration sufficient to reach thermal equilibrium is evaluated with respect to material design temperatures of the HI-STORM 100U overpack. The HI-STORM 100U overpack is conservatively assumed to reach -40°F throughout the structure. Chapter 3, Subsection 3.1.2 details the structural analysis and testing performed to assure prevention of brittle fracture failure of the HI-STORM 100U System.

Shielding

There is no effect on the shielding performance of the system as a result of this off-normal event.

Criticality

There is no effect on the criticality control features of the system as a result of this off-normal event.

Confinement

There is no effect on the confinement function of the MPC as a result of this off-normal event.

Radiation Protection

Since there is no degradation in shielding or confinement capabilities as discussed above, there is no effect on occupational or public exposures as a result of this off-normal event.

Based on this evaluation, it is concluded that the specified off-normal environmental temperatures do not affect the safe operation of the HI-STORM 100U System.

11.I.1.3 Leakage of One MPC Seal Weld

A discussion of this off-normal condition is presented in Subsection 11.1.3 of the main body of Chapter 11. The discussion presented therein is applicable in its entirety to an MPC in a HI-STORM 100U VVM as well.

11.I.1.4 Partial Blockage of Air Inlets

A discussion of this off-normal condition is presented in Subsection 11.1.4 of the main body of Chapter 11. A description of the cause of, detection of, corrective actions for and radiological impact of this event is presented therein.

Structural

There are no structural consequences as a result of this off-normal event.

Thermal

Supplement 4.I calculates bounding temperatures for 50% blockage of the air inlets. The calculated bounding temperatures are reported in Table 4.I.6 and are below the MPC and VVM off-normal design temperatures (Tables 2.2.3 and 2.I.8). Additionally, the increased temperatures generate an elevated MPC internal pressure, also reported in Table 4.I.6, which is less than the off-normal design pressure (Table 2.2.1).

Shielding

There is no effect on the shielding performance of the system as a result of this off-normal event.

Criticality

There is no effect on the criticality control features of the system as a result of this off-normal event.

Confinement

There is no effect on the confinement function of the MPC as a result of this off-normal event.

Radiation Protection

Since there is no degradation in shielding or confinement capabilities as discussed above, there is no effect on occupational or public exposures as a result of this off-normal event.

Based on this evaluation, it is concluded that the specified off-normal partial blockage of air inlet ducts event does not affect the safe operation of the HI-STORM 100U System.

11.1.1.5 Off-Normal Handling of HI-TRAC

A discussion of this off-normal condition is presented in Subsection 11.1.5 of the main body of Chapter 11. The discussion presented therein remains completely applicable, as the design and method of operation of the HI-TRAC is the same as with the HI-STORM 100U.

11.1.1.6 Failure of FHD System

A discussion of this off-normal condition is presented in Subsection 11.1.6 of the main body of Chapter 11. The discussion presented therein remains completely applicable for all MPCs.

11.1.1.7 SCS Power Failure

A discussion of this off-normal condition is presented in Subsection 11.1.7 of the main body of Chapter 11. The discussion presented therein remains completely applicable to all MPCs.

11.1.1.8 Off-Normal Wind

The HI-STORM 100U is designed for use at any site in the United States. Supplement 4.I evaluates the effects of off-normal wind (>0 and up to 15 MPH). The off-normal wind is postulated as a constant horizontal wind caused by extreme weather conditions (see Table 2.I.1). To determine the effects of the off-normal wind, it is conservatively assumed that these winds persist for a sufficient duration to allow the HI-STORM 100U System to reach thermal equilibrium. Because of the large mass of the HI-STORM 100U System with its corresponding large thermal inertia and the unlikely condition of a unidirectional wind for a long period of time, this assumption is conservative. The analyses presented in Supplement 4.I shows that the peak fuel cladding and material temperatures remains below the off-normal limits (Tables 2.2.3 and 2.I.8). Because the HI-STORM 100U System is designed to withstand the off-normal wind without any effect on its ability to maintain safe storage conditions, there is no requirement for detection of the off-normal wind.

Structural

There are no structural consequences as a result of this off-normal event.

Thermal

Supplement 4.I calculates peak fuel cladding temperatures for horizontal wind speeds of up to 15 miles per hour. The calculated temperatures (reported in Table 4.I.7) are below the off-normal limits (Table 2.2.3).

Shielding

There is no effect on the shielding performance of the system as a result of this off-normal event.

Criticality

There is no effect on the criticality control features of the system as a result of this off-normal event.

Confinement

There is no effect on the confinement function of the MPC as a result of this off-normal event.

Radiation Protection

Since there is no degradation in shielding or confinement capabilities as discussed above, there is no effect on occupational or public exposures as a result of this off-normal event.

Based on this evaluation, it is concluded that the specified off-normal wind event does not affect the safe operation of the HI-STORM 100U System. The HI-STORM 100U System is designed to withstand the off-normal wind without any effect on its ability to maintain safe storage conditions. There are no corrective actions required for the off-normal wind. The off-normal wind has no radiological impact, and the confinement barrier and shielding integrity are not affected.

11.1.1.9 HI-TRAC Off-Normal Ambient Temperature

A discussion of this off-normal condition is presented in Subsection 11.1.8 of the main body of Chapter 11. The discussion presented therein remains completely applicable as the design and method of operation of the HI-TRAC under the HI-STORM 100U is same as under the aboveground system.

11.1.2 ACCIDENT EVENTS

A general discussion of accident events is presented in Section 11.1 of the main body of Chapter 11. The following accident events are discussed in this supplement section:

- HI-TRAC Transfer Cask Handling Accident
- HI-STORM 100U Overpack Handling Accident
- Tip-Over
- Fire Accident
- Partial Blockage of MPC Basket Vent Holes
- Tornado
- Flood
- Earthquake
- 100% Fuel Rod Rupture
- Confinement Boundary Leakage
- Explosion
- Lightning

HOLTEC INTERNATIONAL COPYRIGHTED MATERIAL

100% Blockage of Air Inlets
Burial Under Debris
Extreme Environmental Temperature
SCS Failure

The results of the evaluations performed herein demonstrate that the HI-STORM 100U System can withstand the effects of all credible and hypothetical accident conditions and natural phenomena without affecting safety function, and is in compliance with the applicable acceptance criteria.

In addition to the above accidents events, identification of additional hazards during construction proximate to an operating ISFSI is treated in 11.I.2.17.

11.I.2.1 HI-TRAC Transfer Cask Handling Accident

A discussion of this accident condition is presented in Subsection 11.2.1 of the main body of Chapter 11. The discussion presented therein is applicable in its entirety, as the design and method of operation of the HI-TRAC is the same for the HI-STORM 100U.

11.I.2.2 HI-STORM Overpack Handling Accident

This accident event is not applicable to the HI-STORM 100U as this is an underground overpack surrounded by soil.

11.I.2.3 Tip-Over

This accident event is not applicable to the HI-STORM 100U. Due to the subterranean installation of the VVM with a surrounding subgrade for lateral support, tip-over is precluded.

11.I.2.4 Fire Accident

A discussion of this accident condition is presented in Subsection 11.2.4 of the main body of Chapter 11. A description of the cause of and corrective actions for this event is presented therein. In addition, the discussion of the fire analysis for the HI-TRAC transfer cask presented therein remains completely applicable, as the design and method of operation of the HI-TRAC do not need to be changed for use with the HI-STORM 100U.

Structural

There are no structural consequences as a result of the fire accident condition.

Thermal

Supplement 4.I discusses the impact of a fire on the HI-STORM 100U System. As justified therein, the evaluation for the fire effects on an aboveground cask presented in Section 11.2

HOLTEC INTERNATIONAL COPYRIGHTED MATERIAL

bound the effects on the HI-STORM 100U System. As described in Section 11.2, the effects of the fire do not cause any system component or the contained fuel to exceed any design limit. As such, the results are bounding for the HI-STORM 100U System.

Shielding

With respect to concrete damage from a fire, NUREG-1536 (4.0,V,5.b) states: "The loss of a small amount of shielding material is not expected to cause a storage system to exceed the regulatory requirements in 10 CFR 72.106 and, therefore, need not be estimated or evaluated in the SAR."

Criticality

There is no effect on the criticality control features of the system as a result of this accident event.

Confinement

There is no effect on the confinement function of the MPC as a result of this accident event.

Radiation Protection

Since there is a very localized reduction in shielding and no effect on the confinement capabilities as discussed above, there is no effect on occupational or public exposures as a result of this accident event.

Based on this evaluation, it is concluded that the overpack fire accident does not affect the safe operation of the HI-STORM 100U System.

11.I.2.5 Partial Blockage of MPC Basket Vent Holes

A discussion of this accident condition is presented in Subsection 11.2.5 of the main body of Chapter 11. The discussion presented therein is applicable in its entirety to an MPC in a HI-STORM 100U VVM.

11.I.2.6 Tornado

A discussion of this accident condition is presented in Subsection 11.2.6 of the main body of Chapter 11. A description of the cause of and corrective actions for this event is presented therein.

Because of its underground construction, the HI-STORM 100U is not affected by the tornado wind. The effect of tornado missiles propelled by high velocity winds that attempt to penetrate the exposed portions of the HI-STORM 100U must, however, be considered.

Structural

Analyses presented in Supplement 3.I show that the impact of an intermediate tornado missile on the HI-STORM 100U closure lid does not result in the perforation of the lid or result in a structural collapse. The result of the tornado missile impact on the VVM is limited to localized damage of the shielding.

Thermal

There are no thermal consequences as a result of the tornado beyond those discussed for the wind herein.

Shielding

A tornado missile may cause localized damage to the HI-STORM 100U closure lid. As the HI-STORM 100U top is heavily shielded (a thick MPC lid backed up by a steel-concrete-steel top) the overall damage consequences (site boundary dose) are insignificant.

Criticality

There is no effect on the criticality control features of the system as a result of this accident event.

Confinement

There is no effect on the confinement function of the MPC as a result of this accident event.

Radiation Protection

There is no degradation in confinement capabilities of the MPC, since the tornado missiles do not impact the MPC, as discussed above. A tornado missile may cause localized damage in the HI-STORM 100U closure lid. However, the damage will have a negligible effect on the site boundary dose.

Based on this evaluation, it is concluded that the tornado accident does not affect the safe operation of the HI-STORM 100U System.

11.I.2.7 Flood

A discussion of this accident condition is presented in Subsection 11.2.7 of the main body of Chapter 11. A description of the cause of this event is presented therein.

Structural

The structural evaluation of the MPC for the accident condition external pressure (Table 2.2.1) is presented in Section 3.4 and the resulting stresses from this event are shown to be well within the allowable values.

Thermal

The thermal consequences of flood are bounded by the 100% air inlets blockage accident (see Subsection 4.1.6.2).

Shielding

There is no effect on the shielding performance of the system as a result of this accident event. The floodwater provides additional shielding which reduces radiation dose.

Criticality

There is no effect on the criticality control features of the system as a result of this accident event. The criticality analysis is unaffected because under the flooding condition water does not enter the MPC cavity and therefore the reactivity would be less than the loading condition in the spent fuel pool, which is presented in Section 6.1.

Confinement

There is no effect on the confinement function of the MPC as a result of this accident event. As discussed in the structural evaluation above, all stresses remain within allowable values, assuring confinement boundary integrity.

Radiation Protection

Since there is no degradation in shielding or confinement capabilities as discussed above, there is no effect on occupational or public exposures as a result of this accident event.

Based on this evaluation, it is concluded that the flood accident does not affect the safe operation of the HI-STORM 100U System.

Flood Accident Corrective Action

The configuration of the VVM makes it uniquely suited to withstand a flooding event. Indeed, introducing water in the CEC is an effective method to lower the MPC contents' temperature. However, solid debris packed around the Divider Shell is an undesirable condition. Thus, while the thermal evaluations discussed in Supplement 4.I demonstrate that the HI-STORM 100U System will safely withstand a flood, corrective actions after such an event may be necessary. Periodic VVM air temperature monitoring, required for the HI-STORM 100U System, will

identify any blockage of the cooling passages that results in a non-normal thermal condition, including blockages due to a flood borne debris.

If the measured temperature rise exceeds the allowable value, then corrective actions to alleviate the condition will be required. To restore the system to a normal configuration, all flood water and any debris deposited by the receding water must be removed. The specific methods to be used are appropriately site specific and shall be addressed in the site emergence action plan. Examples of acceptable cleaning approaches include:

1. The MPC is removed from the VVM using the HI-TRAC transfer cask, allowing direct access to the interior of the VVM through both the inlet vents and the top of the module cavity. Water sprays and vacuuming is used to directly clean the VVM passages and surfaces.
2. Appropriate vacuuming equipment is inserted through the inlet ducts and down to the bottom plenum. Water is sprayed in through the outlet vents. Remote cameras are used to inspect the VVM cooling passages to identify debris and remove debris.

The adequacy of the cooling passages clearance operation is verified by visual inspection or, if the optional air temperature monitoring is used, the return of the air outlet temperatures to within allowable limits.

11.1.2.8 Earthquake

A discussion of this accident condition is presented in Subsection 11.2.8 of the main body of Chapter 11. A description of the cause of and corrective actions for this event is presented therein.

Structural

Because of its underground construction, the HI-STORM 100U VVM is inherently safe under seismic events. Analyses presented in Supplement 3.I show that the VVM will continue to render its intended function under a seismic event whose ZPAs are bounded by the values set forth in Supplement 2.I.

Thermal

There is no effect on the thermal performance of the system as a result of this accident event.

Shielding

There is no effect on the shielding performance of the system as a result of this accident event.

Criticality

There is no effect on the criticality control features of the system as a result of this accident event.

Confinement

There is no effect on the confinement function of the MPC as a result of this accident event.

Radiation Protection

Since there is no degradation in shielding or confinement capabilities as discussed above, there is no effect on occupational or public exposures as a result of this accident event.

Based on this evaluation, it is concluded that the earthquake does not affect the safe operation of the HI-STORM 100U System.

11.1.2.9 100% Fuel Rod Rupture

A discussion of this accident condition is presented in Subsection 11.2.9 of the main body of Chapter 11. A description of the cause of and corrective actions for this event is presented therein.

Structural

The structural evaluation of the MPC for the accident condition internal pressure presented in Section 3.4 demonstrates that the MPC stresses are well within the allowable values.

Thermal

A bounding MPC internal pressure for the 100% fuel rod rupture condition is presented in Table 4.4.9. The design basis accident condition MPC internal pressure (Table 2.2.1) used in the structural evaluation bounds the calculated value.

Shielding

There is no effect on the shielding performance of the system as a result of this accident event.

Criticality

There is no effect on the criticality control features of the system as a result of this accident event.

Confinement

There is no effect on the confinement function of the MPC as a result of this accident event. As discussed in the structural evaluation above, all stresses remain within allowable values, assuring confinement boundary integrity.

Radiation Protection

Since there is no degradation in shielding or confinement capabilities as discussed above, there is no effect on occupational or public exposures as a result of this accident event.

Based on this evaluation, it is concluded that the non-mechanistic 100% fuel rod rupture accident does not affect the safe operation of the HI-STORM 100U System.

11.I.2.10 Confinement Boundary Leakage

A discussion of this accident condition is presented in Subsection 11.2.10 of the main body of Chapter 11. The discussion presented therein remains completely applicable to an MPC in a HI-STORM 100U VVM as well.

11.I.2.11 Explosion

A discussion of this accident condition is presented in Subsection 11.2.11 of the main body of Chapter 11. A description of the cause of and corrective actions for this event is presented therein.

Structural

Because of its underground construction, the HI-STORM 100U and the MPC contained within are essentially shielded by the surrounding earth. Thus, no evaluation of the VVM or the contained MPC is required. The HI-STORM 100U closure lid is, however, aboveground and exposed to the explosion-induced pressure wave. Supplement 3.I includes an evaluation of the effect of the design-basis 10 psi pressure wave applied as a static pressure on the closure lid. This evaluation shows that the overpressure wave does not result in lid separation, and that all lid stresses are a fraction of the allowable limits.

Thermal

There is no effect on the thermal performance of the system as a result of this accident event.

Shielding

There is no effect on the shielding performance of the system as a result of this accident event.

Criticality

There is no effect on the criticality control features of the system as a result of this accident event.

Confinement

There is no effect on the confinement function of the MPC as a result of this accident event. As discussed in the structural evaluation above, all stresses remain well within allowable values, assuring confinement boundary integrity.

Radiation Protection

Since there is no degradation in shielding or confinement capabilities as discussed above, there is no effect on occupational or public exposures as a result of this accident event.

Based on this evaluation, it is concluded that the explosion accident does not affect the safe operation of the HI-STORM 100U System.

11.I.2.12 Lightning

A discussion of this accident condition is presented in Subsection 11.2.12 of the main body of Chapter 11. A description of the cause of and corrective actions for this event is presented therein.

Because of its underground construction, the subterranean portion of the HI-STORM 100U would not be subjected to a direct lightning strike. The HI-STORM 100U closure lid is, however, aboveground and could be subjected to a direct strike. The closure lid is, however, a steel encased concrete structure just like on the aboveground casks. Thus, the discussion presented in Subsection 11.2.12 remains completely applicable to the exposed portions of the HI-STORM 100U System. Therefore, it is concluded that a lightning event will not prevent the VVM from rendering its intended function.

11.I.2.13 100% Blockage of Air Inlets

A discussion of this accident condition is presented in Subsection 11.2.13 of the main body of Chapter 11. A description of the cause of and corrective actions for this event is presented therein.

Structural

There are no structural consequences as a result of this accident event.

Thermal

Supplement 4.I calculates bounding temperatures for the 100% blockage of the air inlets. The calculated bounding temperatures after 24 hours of 100% blockage are reported in Table 4.I.9. The results are below the MPC and VVM accident temperature limits (Tables 2.2.3 and 2.I.8). Additionally, the increased temperatures generate an elevated MPC internal pressure, also reported in Table 4.I.9, which is less than the design basis accident pressure listed in Table 2.2.1.

Shielding

There is no effect on the shielding performance of the system as a result of this accident event, since the concrete temperatures do not exceed the accident temperature limit.

Criticality

There is no effect on the criticality control features of the system as a result of this accident event.

Confinement

There is no effect on the confinement function of the MPC as a result of this accident event.

Radiation Protection

Since there is no degradation in shielding or confinement capabilities as discussed above, there is no effect on occupational or public exposures as a result of this accident event.

Based on this evaluation, it is concluded that the 100% blockage of air inlets accident does not affect the safe operation of the HI-STORM 100 System, if the blockage is removed in the specified time period.

11.I.2.14 Burial Under Debris

A discussion of this accident condition is presented in Subsection 11.2.14 of the main body of Chapter 11. A description of the cause of and corrective actions for this event is presented therein.

Structural

The structural evaluation of the MPC enclosure vessel for accident internal pressure conditions bounds the pressure calculated herein. Therefore, the resulting stresses from this event are well within the allowable values, as demonstrated in Section 3.4.

Thermal

Supplement 4.I discusses the impact of burial under debris on the HI-STORM 100U System. As explained therein, the evaluation for the effects of such an event on an aboveground cask presented in Section 11.2 bound the HI-STORM 100U.

Shielding

There is no adverse effect on the shielding performance of the system as a result of this accident event.

Criticality

There is no effect on the criticality control features of the system as a result of this accident event.

Confinement

There is no effect on the confinement function of the MPC as a result of this accident event. As discussed in the structural evaluation above, all stresses remain within allowable values, assuring confinement boundary integrity.

Radiation Protection

Since there is no degradation in shielding or confinement capabilities as discussed above, there is no effect on occupational or public exposures as a result of this accident event.

Based on this evaluation, it is concluded that the burial under debris accident does not affect the safe operation of the HI-STORM 100U System, if the debris is removed within the specified time period.

11.1.2.15 Extreme Environmental Temperature

A discussion of this accident condition is presented in Subsection 11.2.15 of the main body of Chapter 11. A description of the cause of and corrective actions for this event is presented therein.

Structural

The structural evaluation of the MPC enclosure vessel for accident condition internal pressure bounds the pressure resulting from this event. Therefore, the resulting stresses from this event are bounded by the design-basis internal pressure and are well within the allowable values, as discussed in Section 3.4.

Thermal

Supplement 4.I calculates bounding temperatures for the HI-STORM 100U under the extreme environmental temperature condition. The calculated bounding temperatures and pressures are reported in Table 4.I.8 and are below the MPC and VVM accident temperature and pressure limits (Tables 2.2.3, 2.1.8 and 2.2.1).

Shielding

There is no effect on the shielding performance of the system as a result of this accident event, since the concrete temperature does not exceed the short-term temperature limit specified in Table 2.2.3.

Criticality

There is no effect on the criticality control features of the system as a result of this accident event.

Confinement

There is no effect on the confinement function of the MPC as a result of this accident event. As discussed in the structural evaluation above, all stresses remain within allowable values, assuring confinement boundary integrity.

Radiation Protection

Since there is no degradation in shielding or confinement capabilities as discussed above, there is no effect on occupational or public exposures as a result of this accident event.

Based on this evaluation, it is concluded that the extreme environment temperature accident does not affect the safe operation of the HI-STORM 100U System.

11.I.2.16 Supplemental Cooling System (SCS) Failure

A discussion of this accident condition is presented in Subsection 11.2.16 of the main body of Chapter 11. The discussion presented therein remains completely applicable, as the design and method of operation of the SCS and the HI-TRAC is unchanged for use with the HI-STORM 100U System.

11.I.2.17 Additional Hazards during Construction Proximate to the ISFSI

To protect an installed ISFSI from any site construction activity in its proximity, a certain minimum ground buffer distance beyond the edge of the perimeter of the VVM arrays shall be established. This distance, referred to as the Excavation Exclusion Zone (EEZ), is the minimum distance from the ISFSI where excavation can occur if a retaining wall was not installed at the

ISFSI per the licensing drawing and Table 2.I.2. This distance is established based on soil conditions and the strength of the DBE as discussed in Section 3.I. If the user installs a retaining wall at or beyond the Radiation Protection Space (RPS) then the EEZ boundary is the retaining wall (see Section 2.I.2, item vi). If a retaining wall is not installed, the EEZ boundary for a site is established using the methodology described in Section 3.I.4.

As is required for deploying casks certified under 10CFR72, Subpart L, every site modification that may potentially impact the continued operability of the ISFSI must be evaluated for acceptability under 10CFR72.212. A generic evaluation of the shielding consequences of digging a cavity adjacent to the RPS has been considered in Supplement 5.I of this FSAR. The analyses show that the dose at the edge of the cavity is below 0.2 mrem/hr, which is well below the customary limit that requires radiation posting at nuclear power plants.

Subsection 2.I.6 considers loadings from extreme environmental phenomena assuming that a deep cavity at the edge of the RPS perimeter with a retaining wall has been created as a part of site construction work and an accidental mechanical loading event across such cavity is credible. Analyses summarized in Subsection 3.I.4 show that the design basis projectiles (large, medium, or small), specified in Chapter 2 of this FSAR, applied in the most vulnerable location of the construction cavity, will fail to reach the CEC.

In addition to the generic analyses documented in this FSAR to validate the sufficiency of the RPS boundary, analyses of the consequences of any credible site specific loads or events during site construction work shall be performed with due consideration of the duration and nature of the site construction activity. The user's §72.212 evaluation program, used in considering ISFSI-proximate activities at aboveground ISFSIs, shall apply to the HI-STORM 100U installation as well without limitation.

To summarize, as discussed in Supplement 2.I and documented in the licensing drawing package in Section 1.5, and the technical specifications; an RPS has been established per Supplement 5.I with sufficient margin (ground buffer) against design basis projectiles analyzed in Supplement 3.I. An EEZ shall be established within which excavation activities cannot be performed. If the retaining wall is present at or beyond the RPS the EEZ boundary is located at the retaining wall. The RPS boundary and EEZ shall not be encroached upon during any site construction activity (this includes excavation). In addition to the generic analyses documented in this FSAR, site specific evaluation pursuant to §72.212 shall be performed for all other credible hazards that can be postulated during site construction. Administrative controls to guard against accidental human error in excavations (such as encroachment of the RPS) shall be addressed through written procedures consistent with the required controls needed for a safety significant activity within a Part 50 controlled area.

Subsection 2.I.2(iv) also requires the ISFSI owner to perform a seismic analysis of the ISFSI for the instance when the maximum amount of excavation of the area adjacent to the EEZ will exist to show that the RPS will not be encroached upon if a retaining wall is not used or be limited to excavation at a distance ten times the planned excavation depth from the ISFSI. The site's Design Basis Earthquake (DBE) will be used. PRA considerations shall not be used to diminish

the strength of the seismic input. The Design Basis Seismic Model, described in 3.I.4, shall be used with appropriate representation of the construction cavity.

Because the actual projectiles for a specific ISFSI site are often different from the tornado borne missiles analyzed in Supplement 3.I herein, a site specific analysis of the effect of all credible missiles shall be performed assuming that the largest construction cavity adjacent to the ISFSI exists. PRA considerations shall not be used to rule out any missile that has been determined to be credible in the plant's FSAR.

Furthermore, the ISFSI owner shall implement ameliorative measures to prevent unacceptable damage to the ISFSI from any other credible adverse scenarios unique to a site that has not been considered in this FSAR. An example of such a measure is the installation of a berm to protect against environmental events such as soil erosion and mud slides. Such site specific design initiatives at any "100U" ISFSI, like its aboveground counterpart, are within the purview of the plant's §72.212 process.

SUPPLEMENT 11.III

ACCIDENT ANALYSIS OF THE MPC-68M

11.III.0 INTRODUCTION

The MPC-68M is canister which contains a Metamic-HT basket. The Metamic-HT basket has improved heat transfer as well as criticality control. This supplement presents the evaluation of the MPC-68M of the HI-STORM 100 System for the effects of off-normal and postulated accident conditions.

The supplemental information has been presented in the same format as the main body of Chapter 11. The basic changes that have been made on the MPC-68 are discussed in Supplement 1.III. The significant changes include the fuel basket and the precision extruded aluminum shims between the fuel basket and the Enclosure Vessel. The changes result in significant reduction in bending stresses under a canister slap-down event, improved heat transfer and criticality performance of the system.

All the off-normal conditions and the postulated accident conditions have been critically evaluated for the introduction of the MPC-68M. The structural integrity and the thermal performance of the HI-STORM 100 System with the MPC-68M are discussed in Supplement Sections 3.III and 4.III.

This Supplement is in full compliance with NUREG-1536; no exceptions are taken.

11.III.1 OFF-NORMAL CONDITIONS

All the off-normal conditions considered in FSAR Chapter 11 have been evaluated for MPC-68M. The Supplemental Cooling System (SCS) is not required as explained in Supplement Section 4.III. Therefore, the SCS power failure is not applicable. The thermal consequences of the off-normal conditions for the HI-STORM 100 system with the MPC-68M are either the same or bounded by those presented in FSAR Section 11.1. Some additional discussions are provided below.

Supplement Section 4.III.6 provides details of the thermal evaluations for the off-normal conditions.

11.III.1.1 Off-Normal Pressure

The off-normal pressure of the MPC internal cavity is a function of the initial helium fill pressure and the temperature reached within the cavity under normal storage. The normal storage temperature and pressure in the MPC-68M are shown to be bounded by the temperature reported in Section 4.6.

11.III.1.2 Off-Normal Environmental Temperatures

FSAR Section 11.1.2 is applicable.

11.III.1.3 Leakage of One Seal

HOLTEC INTERNATIONAL COPYRIGHTED MATERIAL

FSAR Section 11.1.3 is applicable.

11.III.1.4 Partial Blockage of Air Inlets

Supplement Section 4.III.6 confirms that the thermal consequences of the partial blockage of air inlets are bounded by the same analysis presented in Section 4.6.

11.III.1.5 Off-Normal Handling of HI-TRAC

FSAR Section 11.1.5 is applicable.

11.III.1.6 Malfunction of FHD System

FSAR Section 11.1.6 is applicable.

11.III.1.7 SCS Power Failure

As mentioned earlier the Supplementary Cooling System (SCS) is not necessary and therefore, the SCS power failure is not applicable for MPC-68M.

11.III.2 ACCIDENTS

All the accident conditions considered in the FSAR Chapter 11 have been evaluated for the HI-STORM 100 system with MPC-68M. It has been demonstrated that the consequences of the accident conditions are either the same or bounded by those presented in Chapter 11. Some additional discussions are provided below.

11.III.2.1 HI-TRAC Transfer Cask Handling Accident

Supplement Section 3.III.4 evaluated the potential consequences of the HI-TRAC drop events for a loaded MPC-68M inside the HI-TRAC and concluded that the drop analyses presented in the FSAR Subsection 3.4.9 are valid.

11.III.2.2 HI-STORM Overpack Handling Accident

Supplement Section 3.III.4 evaluated the potential consequences of the drop events for HI-STORM overpack carrying the loaded MPC-68M and concluded that although the resulting deceleration is higher than the maximum deceleration calculated in the FSAR Appendix 3.A, it is still less than the design basis vertical deceleration limit.

11.III.2.3 Tip-Over

Supplement Section 3.III.4 evaluated the potential consequences of the non-mechanistic tip-over of the HI-STORM overpack the loaded MPC-68M on to the ISFSI pad carrying. It is concluded that the resulting deceleration is less than the design basis deceleration limit. Also the total deformations of the basket walls during accident conditions are far below the limit imposed in the structural analysis in Supplement 3.III and analyzed in the criticality analysis in Supplement 6.III.

11.III.2.4 Fire Accident

It is concluded in the Supplement Section 4.III.6 that the thermal consequences of fire accident are bounded by those presented in the FSAR Section 4.6. Therefore, FSAR Section 11.2 is applicable.

11.III.2.5 Partial Blockage of MPC Basket Vent Holes

The MPC-68M basket vent holes are located above the level of the maximum accumulation of debris. The blockage of the vent holes is not credible. The evaluation in the FSAR Section 11.2.5 can be considered as bounding.

11.III.2.6 Tornado

It is concluded in Supplement Section 3.III.4 that the tornado loads due to missile impact/wind and depressurization presented in FSAR Subsection 3.4.8 are bounding for the MPC-68M inside a HI-

STORM overpack. It is also concluded that the missile penetration analyses presented in Subsection 3.4.8 remain valid. Therefore, FSAR Section 11.2 is applicable.

11.III.2.7 Flood

It is concluded in the Supplement Section 4.III.6 that the thermal consequences of fire accident are bounded by those presented in the FSAR Section 4.6. Therefore, FSAR Section 11.2 is applicable.

11.III.2.8 Earthquake

It is concluded in Supplement Section 3.III.4 that the seismic analyses presented in FSAR Chapter 3 bound the scenario of a loaded MPC-68M inside a HI-STORM overpack. Therefore, FSAR Section 11.2 is applicable.

11.III.2.9 100% Fuel Rod Rupture

It is concluded in the Supplement Section 4.III.6 that the thermal consequences of the 100% fuel rod rupture are bounded by those presented in the FSAR Section 4.6. Therefore, FSAR Section 11.2 is applicable.

11.III.2.10 Confinement Boundary Leakage

FSAR Section 11.2 is applicable.

11.III.2.11 Explosion

It is concluded in Supplement Section 3.III.4 that the seismic analyses presented in FSAR Chapter 3 bound the scenario of a loaded MPC-68M inside a HI-STORM overpack. Therefore, FSAR Section 11.2 is applicable.

11.III.2.12 Lightning

FSAR Section 11.2 is applicable.

11.III.2.13 100% Blockage of Air Inlets

It is concluded in the Supplement Section 4.III.6 that the thermal consequences of 100% blockage of air inlets are bounded by those presented in the FSAR Section 4.6. Therefore, FSAR Section 11.2 is applicable.

11.III.2.14 Burial Under Debris

It is concluded in the Supplement Section 4.III.6 that the thermal consequences of burial under debris are bounded by those presented in the FSAR Section 4.6. Therefore, FSAR Section 11.2 is

applicable.

11.III.2.15 Extreme Environmental Temperature

As discussed earlier the Supplemental Cooling System (SCS) is not required for the HI-STORM 100 system with the MPC-68M canister.

It is concluded in the Supplement Section 4.III.6 that the thermal consequences of extreme environmental temperature are bounded by those presented in the FSAR Section 4.6. Therefore, FSAR Section 11.2 is applicable.

Based on above discussions it can be concluded the consequences of the off-normal and postulated accident conditions are basically the same or bounded by those presented the FSAR Chapter 11.

11.III.2.16 Supplemental Cooling System (SCS) Failure

As discussed earlier the Supplemental Cooling System (SCS) is not required for the HI-STORM 100 system with the MPC-68M canister.

CHAPTER 12†: OPERATING CONTROLS AND LIMITS

12.0 INTRODUCTION

The HI-STORM 100 System provides passive dry storage of spent fuel assemblies in interchangeable MPCs with redundant multi-pass welded closure. The loaded MPC is enclosed in a single-purpose vertical ventilated module or overpack. This chapter defines the operating controls and limits (i.e., Technical Specifications) including their supporting bases for deployment and storage of a HI-STORM 100 System at an ISFSI. The information provided in this Chapter is in full compliance with NUREG-1536 [12.1.1].

† This chapter has been prepared in the format and section organization set forth in Regulatory Guide 3.61. However, the material content of this chapter also fulfills the requirements of NUREG-1536. Pagination and numbering of sections, figures, and tables are consistent with the convention set down in Chapter 1, Section 1.0, herein. Finally, all terms-of-art used in this chapter are consistent with the terminology of the glossary (Table 1.0.1) and component nomenclature of the Bill-of-Materials (Section 1.5).

12.1 PROPOSED OPERATING CONTROLS AND LIMITS

12.1.1 NUREG-1536 (Standard Review Plan) Acceptance Criteria

12.1.1.1 This portion of the FSAR establishes the commitments regarding the HI-STORM 100 System and its use. Other 10CFR72 [12.1.2] and 10CFR20 [12.1.3] requirements in addition to the Technical Specifications may apply. The conditions for a general license holder found in 10CFR72.212 [12.1.2] shall be met by the licensee prior to loading spent fuel into the HI-STORM 100 System. The general license conditions governed by 10CFR72 [12.1.2] are not repeated with these Technical Specifications. Licensees are required to comply with all commitments and requirements.

12.1.1.2 The Technical Specifications provided in Appendix A and A-100U to CoC 72-1014 and the authorized contents and design features provided in Appendix B and B-100U to CoC 72-1014 are primarily established to maintain subcriticality, confinement boundary and intact fuel cladding integrity, shielding and radiological protection, heat removal capability, and structural integrity under normal, off-normal and accident conditions. Table 12.1.1 addresses each of these conditions respectively and identifies the appropriate Technical Specification(s) designed to control the condition. Table 12.1.2 provides the list of Technical Specifications for the HI-STORM 100 System.

Table 12.1.1
HI-STORM 100 SYSTEM CONTROLS

Condition to be Controlled	Applicable Technical Specifications [†]
Criticality Control	3.3.1 Boron Concentration
Confinement Boundary and Intact Fuel Cladding Integrity	3.1.1 Multi-Purpose Canister (MPC) 3.1.4 Supplemental Cooling System
Shielding and Radiological Protection	3.1.1 Multi-Purpose Canister (MPC) 3.1.3 Fuel Cool-Down 3.2.2 TRANSFER CASK Surface Contamination 5.4 Radioactive Effluent Control Program 5.7 Radiation Protection Program
Heat Removal Capability	3.1.1 Multi-Purpose Canister (MPC) 3.1.2 SFSC Heat Removal System 3.1.4 Supplemental Cooling System
Structural Integrity	3.1.5 Impressed Current Cathodic Protection System 5.5 Cask Transport Evaluation Program

[†] Technical Specifications are located in Appendix A to CoC 72-1014. Authorized contents are specified in FSAR Section 2.1.9

Table 12.1.2
HI-STORM 100 SYSTEM TECHNICAL SPECIFICATIONS

NUMBER	TECHNICAL SPECIFICATION
1.0	USE AND APPLICATION 1.1 Definitions 1.2 Logical Connectors 1.3 Completion Times 1.4 Frequency
2.0	Not Used
3.0	LIMITING CONDITION FOR OPERATION (LCO) APPLICABILITY SURVEILLANCE REQUIREMENT (SR) APPLICABILITY
3.1.1	Multi-Purpose Canister (MPC)
3.1.2	SFSC Heat Removal System
3.1.3	Fuel Cool-Down
3.1.4	Supplemental Cooling System
3.1.5	Impressed Current Cathodic Protection System
3.2.1	Deleted
3.2.2	TRANSFER CASK Surface Contamination
3.2.3	Deleted
3.3.1	Boron Concentration
Table 3-1	MPC Cavity Drying Limits
Table 3-2	MPC Helium Backfill Limits
4.0	Not Used
5.0	ADMINISTRATIVE CONTROLS
5.1	Deleted
5.2	Deleted
5.3	Deleted
5.4	Radioactive Effluent Control Program
5.5	Cask Transport Evaluation Program
5.6	Deleted
5.7	Radiation Protection Program
Table 5-1	TRANSFER CASK and OVERPACK Lifting Requirements

HOLTEC INTERNATIONAL COPYRIGHTED MATERIAL

12.2 DEVELOPMENT OF OPERATING CONTROLS AND LIMITS

This section provides a discussion of the operating controls and limits, and training requirements for the HI-STORM 100 System to assure long-term performance consistent with the conditions analyzed in this FSAR.

12.2.1 Training Modules

Training modules are to be developed under the licensee's training program to require a comprehensive, site-specific training, assessment, and qualification (including periodic re-qualification) program for the operation and maintenance of the HI-STORM 100 Spent Fuel Storage Cask (SFSC) System and the Independent Spent Fuel Storage Installation (ISFSI). The training modules shall include the following elements, at a minimum:

1. HI-STORM 100 System Design (overview);
2. ISFSI Facility Design (overview);
3. Systems, Structures, and Components Important to Safety (overview);
4. HI-STORM 100 System Final Safety Analysis Report (overview);
5. NRC Safety Evaluation Report (overview);
6. Certificate of Compliance conditions;
7. HI-STORM 100 Technical Specifications, Approved Contents, Design Features and other Conditions for Use;
8. HI-STORM 100 Regulatory Requirements (e.g., 10CFR72.48, 10CFR72, Subpart K, 10CFR20, 10CFR73);
9. Required instrumentation and use;
10. Operating Experience Reviews
11. HI-STORM 100 System and ISFSI Procedures, including
 - Procedural overview
 - Fuel qualification and loading
 - MPC /HI-TRAC/overpack rigging and handling, including safe load pathways
 - MPC welding operations
 - HI-TRAC/overpack/VVM closure
 - Auxiliary equipment operation and maintenance (e.g., draining, moisture removal, helium backfilling, supplemental cooling (if used), and cooldown)

HOLTEC INTERNATIONAL COPYRIGHTED MATERIAL

- MPC/HI-TRAC/overpack/VVM pre-operational and in-service inspections and tests
- Transfer and securing of the loaded HI-TRAC/overpack onto the transport vehicle
- Transfer and offloading of the HI-TRAC/overpack
- Preparation of MPC/HI-TRAC/overpack/VVM for fuel unloading
- Unloading fuel from the MPC/HI-TRAC/overpack/VVM
- Surveillance
- Radiation protection
- Maintenance
- Security
- Off-normal and accident conditions, responses, and corrective actions

12.2.2 Dry Run Training

A dry run training exercise of the loading, closure, handling, and transfer of the HI-STORM 100 System shall be conducted by the licensee prior to the first use of the system to load spent fuel assemblies. The dry run shall include, but is not limited to the following:

1. Receipt inspection of HI-STORM 100 System components.
2. Moving the HI-STORM 100 MPC/HI-TRAC into the spent fuel pool.
3. Preparation of the HI-STORM 100 System for fuel loading.
4. Selection and verification of specific fuel assemblies to ensure type conformance.
5. Locating specific assemblies and placing assemblies into the MPC (using a dummy fuel assembly), including appropriate independent verification.
6. Remote installation of the MPC lid and removal of the MPC/HI-TRAC from the spent fuel pool.
7. Replacing the HI-TRAC pool lid with the transfer lid (HI-TRAC 100 and 125 only).
8. MPC welding, NDE inspections, pressure testing, draining, moisture removal, and helium backfilling (for which a mockup may be used).
9. HI-TRAC upending/downending on the horizontal transfer trailer or other transfer device, as applicable to the site's cask handling arrangement.
10. Placement of the HI-STORM 100 System at the ISFSI.
11. HI-STORM 100 System unloading, including cooling fuel assemblies, flooding the MPC cavity, and removing MPC welds (for which a mock-up may be used).

12. Installation and operation of the Supplemental Cooling System (if used).

12.2.3 Functional and Operating Limits, Monitoring Instruments, and Limiting Control Settings

The controls and limits apply to operating parameters and conditions which are observable, detectable, and/or measurable. The HI-STORM 100 System is completely passive during storage and requires no monitoring instruments. The user may choose to implement a temperature monitoring system to verify operability of the overpack heat removal system in accordance with Technical Specification Limiting Condition for Operation (LCO) 3.1.2.

12.2.4 Limiting Conditions for Operation

Limiting Conditions for Operation specify the minimum capability or level of performance that is required to assure that the HI-STORM 100 System can fulfill its safety functions.

12.2.5 Equipment

The HI-STORM 100 System and its components have been analyzed for specified normal, off-normal, and accident conditions, including extreme environmental conditions. Analysis has shown in this FSAR that no credible condition or event prevents the HI-STORM 100 System from meeting its safety function. As a result, there is no threat to public health and safety from any postulated accident condition or analyzed event. When all equipment is loaded, tested, and placed into storage in accordance with procedures developed for the ISFSI, no failure of the system to perform its safety function is expected to occur.

12.2.6 Surveillance Requirements

The analyses provided in this FSAR show that the HI-STORM 100 System fulfills its safety functions, provided that the Technical Specifications and the Authorized Contents described in Section 2.1.9 are met. Surveillance requirements during loading, unloading, and storage operations are provided in the Technical Specifications.

12.2.7 Design Features

This section describes HI-STORM 100 System design features that are Important to Safety. These features require design controls and fabrication controls. The design features, detailed in this FSAR and in Appendix B to CoC 72-1014, are established in specifications and drawings which are controlled through the quality assurance program. Fabrication controls and inspections to assure that the HI-STORM 100 System is fabricated in accordance with the design drawings and the requirements of this FSAR are described in Chapter 9.

12.2.8 MPC

- a. Basket material composition, properties, dimensions, and tolerances for criticality control.

- b. Canister material mechanical properties for structural integrity of the confinement boundary.
- c. Canister and basket material thermal properties and dimensions for heat transfer control.
- d. Canister and basket material composition and dimensions for dose rate control.

12.2.9 HI-STORM Overpack/VVM

- a. HI-STORM overpack/VVM material mechanical properties and dimensions for structural integrity to provide protection of the MPC and shielding of the spent nuclear fuel assemblies during loading, unloading and handling operations, as applicable.
- b. HI-STORM overpack/VVM material thermal properties and dimensions for heat transfer control.
- c. HI-STORM overpack/VVM material composition and dimensions for dose rate control.

12.2.10 Verifying Compliance with Fuel Assembly Decay Heat, Burnup, and Cooling Time Limits

The examples below execute the approach and equations described in Section 2.1.9.1 for determining allowable decay heat per storage location, burnup, and cooling time for the approved cask contents.

Example 1

In this example, a demonstration of the use of burnup versus cooling time tables for regionalized fuel loading is provided. In this example it will be assumed that the MPC-32 is being loaded with array/class 16x16A fuel in a regionalized loading pattern and will be stored in an aboveground HI-STORM system.

Step 1: Pick a value of X between 0.5 and 3. For this example X will be 2.8.

Step 2: Calculate q_{Region2} as described in Section 2.1.9.1.2:

$$q_{\text{Region2}} = (2 \times 34) / [(1 + (2.8)^{0.2075}) \times ((12 \times 2.8) + 20)] = 0.5668 \text{ kW}^\dagger$$

Step 3: Calculate q_{Region1} as described in Section 2.1.9.1.2:

$$q_{\text{Region1}} = X \times q_{\text{Region2}} = 2.8 \times 0.5668 = 1.5871 \text{ kW}$$

[†] Results are arbitrarily rounded to four decimal places.

Step 4: Develop a burnup versus cooling time table. Since this table is enrichment dependent, it is permitted and advisable to create multiple tables for different enrichments. In this example, two enrichments will be used: 3.1 and 4.185. Tables 12.2.1 and 12.2.2 show the burnup versus cooling time tables calculated for these enrichments for Region 1 and Region 2 as described in Section 2.1.9.1.3.

Table 12.2.3 provides three hypothetical fuel assemblies in the 16x16A array/class that will be evaluated for acceptability for loading in the MPC-32 example above. The decay heat values in Table 12.2.3 are calculated by the user. The other information is taken from the fuel assembly and reactor operating records.

Fuel Assembly Number 1 is not acceptable for storage because its enrichment is lower than that used to determine the allowable burnups in Table 12.2.1 and 12.1.2. The solution is to develop another table using an enrichment of 3.0 wt.% ²³⁵U or less to determine this fuel assembly's suitability for loading in this MPC-32.

Fuel Assembly Number 2 is not acceptable for loading unless a unique maximum allowable burnup for a cooling time of 3.3 years is calculated by linear interpolation between the values in Table 12.2.1 for 3 years and 4 years of cooling. Linear interpolation yields a maximum burnup of 36,497 MWD/MTU (rounded down from 36,497.2), making Fuel Assembly Number 2 acceptable for loading only in Region 1 due to decay heat limitations.

Fuel Assembly Number 3 is acceptable for loading based on the higher allowable burnups in Table 12.2.2, which were calculated using a higher minimum enrichment than those in Table 12.2.1, which is still below the actual initial enrichment of Fuel Assembly Number 3. Due to its relatively low total decay heat of 0.5 kW (fuel: 0.4, non-fuel hardware: 0.1), Fuel Assembly Number 3 may be stored in Region 1 or Region 2.

Example 2

In this example, each fuel assembly in Table 12.2.3 will be evaluated to determine whether it may be stored in the same hypothetical MPC-32 in a regionalized storage pattern in an aboveground system. Assuming the same value 'X', the same maximum fuel storage location decay heats are calculated. The equation in Section 2.1.9.1.3 is executed for each fuel assembly using its exact initial enrichment to determine its maximum allowable burnup. Linear interpolation is used to further refine the maximum allowable burnup value between cooling times, if necessary.

Fuel Assembly Number 1: The calculated allowable burnup for 3.0 wt.% ²³⁵U and a decay heat value of 1.5871 kW (q_{region1}) is 44,905 MWD/MTU at 4 years minimum cooling. Its decay heat is too high for loading in Region 2. Comparing the fuel assembly burnup and total decay heat of the contents[†] (fuel (1.01 kW) plus non-fuel hardware (0.5 kW)) to the calculated limits indicates that the fuel assembly, including the non-fuel hardware, is acceptable for storage in Region 1.

[†] The assumption is made that the non-fuel hardware meets burnup and cooling time limits in Table 2.1.25.

Fuel Assembly Number 2: The calculated allowable burnup for 3.2 wt.% ^{235}U and a decay heat value of 1.5871 kW (q_{Region1}) is 32,989 MWD/MTU for 3 years cooling and 45,382 MWD/MTU for 4 years cooling. Linearly interpolating between these values for a cooling time of 3.3 years yields a maximum allowable burnup of 36,706 MWD/MTU and, therefore, the assembly is acceptable for storage in Region 1. This fuel assembly's decay heat is also too high for loading in Region 2.

Fuel Assembly Number 3: The calculated allowable maximum burnup for 4.3 wt.% ^{235}U and a decay heat value of 0.5668 (q_{Region2}) is 41,693 MWD/MTU for 18 years cooling. Comparing the fuel assembly burnup and total decay heat of the contents (fuel plus non-fuel hardware) against the calculated limits indicates that the fuel assembly and non-fuel hardware are acceptable for storage. Therefore, the assembly is acceptable for storage in Region 2. This fuel assembly would also be acceptable for loading in Region 1 (this conclusion is inferred, but not demonstrated).

Example 3

In this example, a demonstration of the use of burnup versus cooling time tables for uniform fuel loading is provided. In this example it will be assumed that the MPC-68 is being loaded with array/class 9x9A fuel and will be stored in an aboveground HI-STORM system.

Step 1: CoC TS Appendix B Table 2.4-1 provides the heat load limit on each storage location (q_{max}). For MPC-68 this is 0.5 kW.

Step 2: Develop a burnup versus cooling time table. Since this table is enrichment dependent, it is permitted and advisable to create multiple tables for different enrichments if the fuel being loaded varies significantly in initial enrichment. It is conservative to choose the lowest value of initial enrichment to generate the table.

In this example, two enrichments will be used: 3.0 and 4.5. Tables 12.2.4 and 12.2.5 show the burnup versus cooling time tables calculated for these enrichments for the respective q_{max} .

Table 12.2.6 provides three hypothetical fuel assemblies in the 9x9A array/class that will be evaluated for acceptability for loading in the MPC-68 example above. The decay heat values in Table 12.2.6 would be calculated by the user. The other information would be taken from the fuel assembly and reactor operating records.

All of the assemblies meet the per cell heat load limit of 0.5 kW.

Fuel Assembly Number 1 is acceptable for storage because its enrichment is lower than that used to determine the allowable burnups in Table 12.2.4 and the burnup is lower than that allowed for the cooling time of the assembly.

Fuel Assembly Number 2 is not acceptable for loading based on the current tables. The fuel assembly burnup is greater than allowed by Table 12.2.4, even with linear interpolation (30978 MWD/MTU). Fuel Assembly Number 2 may be acceptable for loading if a new table is created specifically for an initial enrichment of 3.5 wt% and the allowable burnup is greater than 35250.

Fuel Assembly Number 3 is acceptable for loading based on the allowable burnups in Table 12.2.5.

12.2.11 Verifying Compliance with Total MPC Heat Load

Some operational steps and/or use of particular equipment are required if Q_{CoC} is above a certain value, e.g. 28.74 kW in the MPC-32. These include supplemental cooling, forced helium dehydration, helium backfill pressure, and surveillance requirements for LCO 3.1.2. These examples demonstrate the logic behind the decisions for these operational steps. Time to boil limits and vacuum drying are also considered in these examples.

Example 1:

Table 12.2.7 contains a proposed heat load pattern for loading a MPC-68 into an aboveground HI-STORM 100 System. The table provides the decay heat of each storage location. It is assumed that each of these assemblies meets the burnup, cooling time and enrichment criteria for loading as described in the previous examples in Section 12.2.10.

General observations on this loading plan:

1. The heat loads in all cells meet the CoC limits for Uniform Loading, i.e. all cells are ≤ 0.50 kW (See Table 2.1.26).
2. The MPC is loaded preferentially for ALARA considerations, i.e. the assemblies with the lower heat loads are in the peripheral cells.
3. The aggregate MPC heat load, as defined in Section 2.1.9.1.2 as the simple summation of the assemblies in the MPC, is 18.917 kW.
4. The maximum heat load in any cell is 0.460 kW.
5. Q_{CoC} , as defined in Section 2.1.9.1.2 equation c is 31.280 kW.

Recommendations based on the general observations without further site-specific analysis:

1. Vacuum drying: The MPC *cannot* be dried using vacuum drying because the Q_{CoC} heat load is greater than 30 kW (See FSAR Table 4.5.1).
2. Forced Helium Dehydration: The MPC should be dried using forced helium dehydration since the Q_{CoC} heat load exceeds the vacuum drying threshold heat loads (See FSAR Table 4.5.1).
3. Helium Backfill Pressure Range: The MPC should be backfilled to the higher pressure range given in the TS because the Q_{CoC} heat load exceeds the threshold heat loads in FSAR Table 1.2.2.
4. Supplemental Cooling System: A supplemental cooling system would be required for on-site transport of High Burnup Fuel in the HI-TRAC after the MPC is dried, backfilled and sealed because the Q_{CoC} heat load exceeds the 90% design basis threshold heat load in FSAR Table 4.5.4.
5. Heat Removal Surveillance (LCO 3.1.2): The user has 24 hours to clear blockage on

the system containing this MPC since the Q_{CoC} heat load exceeds the 28.152 kW ($=0.414 \text{ kW} \cdot 68$) threshold heat load in LCO 3.1.2.

6. Time to boil determination: The user can calculate the time to boil limit based on the aggregate MPC heat load of 18.917 kW since this is a bulk adiabatic heat up calculation strictly based on the aggregate heat in the MPC.
7. Air mass flow rate test requirements per Condition 9 of the CoC: The user can determine if this test needs to be performed based on the aggregate MPC heat load of 18.917 kW since the air flow on the outside of the MPC is strictly based on the aggregate heat in the MPC.

Example 2

Table 12.2.8 contains a proposed heat load pattern for loading a MPC-32. The table provides the decay heat of each storage location. It is assumed that each of these assemblies meets the burnup, cooling time and enrichment criteria for loading as described in the previous examples in Section 12.2.10.

General observations on this loading plan:

1. The heat loads in all cells meet the CoC limits for Uniform Loading, i.e. all cells are $\leq 1.062 \text{ kW}$ (See Table 2.1.26).
2. The MPC is loaded preferentially for ALARA considerations, i.e. the assemblies with the lower heat loads are in the peripheral cells.
3. The aggregate MPC heat load, as defined in Section 2.1.9.1.2 as the simple summation of the assemblies in the MPC, is 17.471 kW.
4. The maximum heat load in any cell is 0.826 kW.
5. Q_{CoC} , as defined in Section 2.1.9.1.2 equation c is 26.432 kW.

Recommendations based on the general observations without further site-specific analysis:

1. Vacuum drying: The MPC can be dried using vacuum drying since the Q_{CoC} heat load is bounded by the threshold heat load Q_2 in FSAR Table 4.5.1. The vacuum drying is time limited as Q_{CoC} exceeds threshold heat load Q_1 in FSAR Table 4.5.1.
2. Forced Helium Dehydration: The MPC can be dried using forced helium dehydration but it is not required.
3. Helium Backfill Pressure Range: The MPC may be backfilled to either pressure range given in the TS because the Q_{CoC} heat load is bounded by the threshold heat load in FSAR Table 1.2.2.
4. Supplemental Cooling System: A supplemental cooling system would NOT be required for on-site transport in the HI-TRAC after the MPC is dried, backfilled and sealed because the Q_{CoC} heat load is bounded by the 90% design basis threshold heat load in FSAR Table 4.5.4.
5. Heat Removal Surveillance (LCO 3.1.2): The user has 64 hours to clear blockage on

the system containing this MPC since the Q_{CoC} heat load is bounded by the 28.74 kW threshold heat load in LCO 3.1.2.

6. Time to boil determination: The user can calculate the time to boil limit based on the aggregate MPC heat load of 17.471 kW since this is a bulk adiabatic heat up calculation strictly based on the aggregate heat in the MPC.
7. Air mass flow rate test requirements per Condition 9 of the CoC: The user can determine if this test needs to be performed based on the aggregate MPC heat load of 17.471 kW since the air flow on the outside of the MPC is strictly based on the aggregate heat in the MPC.

Example 3

Table 1.2.9 contains a proposed heat load pattern for loading a MPC-32. The table provides the decay heat of each storage location. It is assumed that each of these assemblies meets the burnup, cooling time and enrichment criteria for loading as described in the previous examples in Section 12.2.10.

General observations on this loading plan:

1. The heat loads do not meet the CoC limits for Uniform Loading, i.e. some cells are ≥ 1.0625 kW (See Table 2.1.26).
2. The X value that most closely meets this pattern (See Table 2.1.30) is 1.5 which means the inner locations cannot have a total decay heat greater than 1.282 kW and the outer locations cannot have a total decay heat greater than 0.855 kW. Note that the pattern also meets the criteria for any X value ≥ 1.5 .
3. The aggregate MPC heat load, as defined in Section 2.1.9.1.2 as the simple summation of the assemblies in the MPC, is 20.697 kW.
4. The maximum heat load in any cell is 1.273 kW.
5. Since this MPC is loaded in a regionalized pattern, Q_{CoC} , as defined in Section 2.1.9.1.2 equation e is 32.484 kW. ($12 \times 1.282 + 20 \times 0.855$)

Recommendations based on the general observations without further site-specific analysis:

1. Vacuum drying: The MPC *cannot* be dried using vacuum drying since the Q_{CoC} heat load under uniform loading ($1.273 \text{ kW} \times 32$ equals 40.736 kW) exceeds the threshold heat loads in FSAR Table 4.5.1.
2. Forced Helium Dehydration: The MPC must be dried using forced helium dehydration only because vacuum drying is not permitted (see above) and regionalized loading Q_{CoC} is bounded by the design basis heat load in FSAR Table 4.5.1.
3. Helium Backfill Pressure Range: The MPC must be backfilled to the higher pressure range given in the TS because the uniform loading Q_{CoC} heat load exceeds the threshold heat load in FSAR Table 1.2.2.
4. Supplemental Cooling System: A supplemental cooling system is required for on-site

transport of High Burnup Fuel in the HI-TRAC after the MPC is dried, backfilled and sealed because both uniform loading Q_{CoC} and storage cell heat loads under regionalized storage exceed the 90% design basis threshold heat load in FSAR Table 4.5.4.

5. Heat Removal Surveillance (LCO 3.1.2): The user has 24 hours to clear blockage on the system containing this MPC since the uniform loading Q_{CoC} heat load exceeds the 28.74 kW threshold heat load in LCO 3.1.2.
6. Time to boil determination: The user can calculate the time to boil limit based on the aggregate MPC heat load of 20.697 kW since this is a bulk adiabatic heat up calculation strictly based on the aggregate heat in the MPC.
7. Air mass flow rate test requirements per Condition 9 of the CoC: The user can determine if this test needs to be performed based on the aggregate MPC heat load of 20.697 kW since the air flow on the outside of the MPC is strictly based on the aggregate heat in the MPC.

Table 12.2.1

EXAMPLE BURNUP VERSUS COOLING TIME LIMITS FOR REGIONALIZED LOADING
 (MPC-32, Array/Class 16x16A, X = 2.8, and Enrichment = 3.1 wt.% ²³⁵U)
 (q_{Region 1} = 1.5871 kW, q_{Region 2} = 0.5668 kW)

MINIMUM COOLING TIME (years)	MAXIMUM ALLOWABLE BURNUP IN REGION 1 (MWD/MTU)	MAXIMUM ALLOWABLE BURNUP IN REGION 2 (MWD/MTU)
≥3	32791	10896
≥4	45145	17370
≥5	53769	22697
≥6	59699	26615
≥7	63971	29386
≥8	67343	31437
≥9	68200	33000
≥10	68200	34271
≥11	68200	35384
≥12	68200	36322
≥13	68200	37189
≥14	68200	37980
≥15	68200	38773
≥16	68200	39512
≥17	68200	40234
≥18	68200	40908
≥19	68200	41620
≥20	68200	42324

Table 12.2.2

EXAMPLE BURNUP VERSUS COOLING TIME LIMITS FOR REGIONALIZED LOADING
 (MPC-32, Array/Class 16x16A, X = 2.8, and Enrichment = 4.185 wt.% ²³⁵U)
 ($q_{\text{Region 1}} = 1.5871 \text{ kW}$, $q_{\text{Region 2}} = 0.5668 \text{ kW}$)

MINIMUM COOLING TIME (years)	MAXIMUM ALLOWABLE BURNUP IN REGION 1 (MWD/MTU)	MAXIMUM ALLOWABLE BURNUP IN REGION 2 (MWD/MTU)
≥3	34797	11101
≥4	47590	17870
≥5	56438	23272
≥6	62533	27157
≥7	66963	29907
≥8	68200	31935
≥9	68200	33510
≥10	68200	34785
≥11	68200	35927
≥12	68200	36894
≥13	68200	37790
≥14	68200	38593
≥15	68200	39419
≥16	68200	40191
≥17	68200	40937
≥18	68200	41643
≥19	68200	42363
≥20	68200	43094

Table 12.2.3

SAMPLE CONTENTS TO DETERMINE ACCEPTABILITY FOR STORAGE
(Array/Class 16x16A)

FUEL ASSEMBLY NUMBER	ENRICHMENT (wt. % ²³⁵ U)	FUEL ASSEMBLY BURNUP (MWD/MTU)	FUEL ASSEMBLY COOLING TIME (years)	FUEL ASSEMBLY DECAY HEAT (kW)	NON-FUEL HARDWARE STORED WITH ASSEMBLY	NFH DECAY HEAT (kW)
1	3.0	37100	4.7	1.01	BPRA	0.5
2	3.2	35250	3.3	1.45	NA	NA
3	4.3	41276	18.2	0.4	BPRA	0.1

HOLTEC INTERNATIONAL COPYRIGHTED MATERIAL

Table 12.2.4

EXAMPLE BURNUP VERSUS COOLING TIME LIMITS FOR REGIONALIZED LOADING
 (MPC-68, Array/Class 9x9A, and Enrichment = 3.0 wt.% ²³⁵U)
 ($q_{\max} = 0.5 \text{ kW}$)

MINIMUM COOLING TIME (years)	MAXIMUM ALLOWABLE BURNUP (MWD/MTU)
≥3	27739
≥4	38536
≥5	46268
≥6	51583
≥7	55424
≥8	58303
≥9	60733
≥10	62798
≥11	64609
≥12	66331
≥13	68005
≥14	68200
≥15	68200
≥16	68200
≥17	68200
≥18	68200
≥19	68200
≥20	68200

Table 12.2.5

EXAMPLE BURNUP VERSUS COOLING TIME LIMITS FOR REGIONALIZED LOADING
 (MPC-68, Array/Class 9x9A, and Enrichment =4.5 wt.% ²³⁵U)
 ($q_{max} = 0.5$ kW)

MINIMUM COOLING TIME (years)	MAXIMUM ALLOWABLE BURNUP (MWD/MTU)
≥3	30017
≥4	41399
≥5	49359
≥6	54839
≥7	58856
≥8	61932
≥9	64534
≥10	66802
≥11	68200
≥12	68200
≥13	68200
≥14	68200
≥15	68200
≥16	68200
≥17	68200
≥18	68200
≥19	68200
≥20	68200

Table 12.2.6

SAMPLE CONTENTS TO DETERMINE ACCEPTABILITY FOR STORAGE
(Array/Class 9x9A)

FUEL ASSEMBLY NUMBER	ENRICHMENT (wt. % ²³⁵ U)	FUEL ASSEMBLY BURNUP (MWD/MTU)	FUEL ASSEMBLY COOLING TIME (years)	FUEL ASSEMBLY DECAY HEAT (kW)
1	3.0	37100	4.7	0.3
2	3.5	35250	3.3	0.495
3	4.5	41276	18.2	0.2

Table 12.2.7
 Loading Map for Storage Cells in an MPC-68
 Total Decay Heat (kW)

				0.171	0.170				
		0.175	0.171	0.186	0.183	0.180	0.176		
	0.171	0.300	0.313	0.315	0.310	0.309	0.303	0.169	
	0.172	0.312	0.450	0.456	0.449	0.444	0.302	0.176	
0.170	0.181	0.304	0.446	0.457	0.454	0.454	0.307	0.181	0.169
0.159	0.183	0.317	0.441	0.439	0.460	0.441	0.313	0.186	0.170
	0.174	0.315	0.440	0.437	0.445	0.443	0.311	0.181	
	0.161	0.303	0.304	0.316	0.320	0.301	0.302	0.182	
		0.166	0.173	0.181	0.183	0.182	0.178		
				0.169	0.155				

Table 12.2.8
 Loading Map for Storage Cells in an MPC-32
 Total Decay Heat (kW)

		0.370	0.394	0.392	0.387	
0.395	0.372	0.81	0.817	0.391	0.372	
0.388	0.810	0.818	0.826	0.825	0.375	
0.382	0.820	0.823	0.821	0.812	0.378	
0.384	0.390	0.813	0.824	0.393	0.395	
	0.373	0.372	0.375	0.374		

HOLTEC INTERNATIONAL COPYRIGHTED MATERIAL

Table 12.2.9
 Loading Map for Storage Cells in an MPC-32
 Total Decay Heat (kW)

	0.310	0.349	0.329	0.378	
0.359	0.327	1.110	1.107	0.399	0.372
0.388	1.068	1.207	1.250	1.091	0.373
0.328	1.086	1.273	1.203	1.087	0.374
0.348	0.309	1.100	1.090	0.319	0.375
	0.337	0.327	0.357	0.367	

Technical Specifications for the HI-STORM 100 System are provided in Appendix A to Certificate of Compliance 72-1014. Authorized Contents (i.e., fuel specifications) and Design Features are provided in Appendix B to CoC 72-1014. Bases applicable to the Technical Specifications are provided in FSAR Appendix 12.A. The format and content of the HI-STORM 100 System Technical Specifications and Bases are that of the Improved Standard Technical Specifications for power reactors, to the extent they apply to a dry spent fuel storage cask system. NUMARC Document 93-03, "Writer's Guide for the Restructured Technical Specifications" [12.3.1] was used as a guide in the development of the Technical Specifications and Bases.

12.4 REGULATORY EVALUATION

Table 12.1.2 lists the Technical Specifications for the HI-STORM 100 System. The Technical Specifications are detailed in Appendix A and A-100U to Certificate of Compliance 72-1014. The Authorized Contents (i.e., fuel specifications) and Design Features are provided in Appendix B and B-100U to CoC 72-1014.

The conditions for use of the HI-STORM 100 System identify necessary Technical Specifications, limits on authorized contents (i.e., fuel), and cask design features to satisfy 10 CFR Part 72, and the applicable acceptance criteria have been satisfied. Compliance with these Technical specifications and other conditions of the Certificate of Compliance provides reasonable assurance that the HI-STORM 100 System will provide safe storage of spent fuel and is in compliance with 10 CFR Part 72, the regulatory guides, applicable codes and standards, and accepted practices.

12.5 REFERENCES:

- [12.1.1] U.S. Nuclear Regulatory Commission, NUREG-1536, Standard Review Plan for Dry Cask Storage Systems, Final Report, January 1997.
- [12.1.2] U.S. Code of Federal Regulations, Title 10, Energy, Part 72, Licensing Requirements for Independent Storage of Spent Nuclear Fuel and High-Level Radioactive Waste."
- [12.1.3] U.S. Code of Federal Regulations, Title 10, Energy, Part 20, Standards for Protection Against Radiation."
- [12.3.1] Nuclear Management and Resources Council, Inc. – Writer's Guide for the Restructured Technical Specifications, NUMARC 93-03, February 1993.

HI-STORM 100 SYSTEM FSAR

APPENDIX 12.A

TECHNICAL SPECIFICATION BASES

FOR THE HOLTEC HI-STORM 100 SPENT FUEL STORAGE CASK SYSTEM

HOLTEC INTERNATIONAL COPYRIGHTED MATERIAL

HI-STORM FSAR
REPORT HI-2002444

Rev.3

HI-STORM 100 FSAR, NON-PROPRIETARY
REVISION 12,
MARCH 12, 2014

BASES TABLE OF CONTENTS

3.0	LIMITING CONDITION FOR OPERATION (LCO) APPLICABILITY	B 3.0-1
3.0	SURVEILLANCE REQUIREMENT (SR) APPLICABILITY	B 3.0-5
3.1	SFSC INTEGRITY	B 3.1.1-1
3.1.1	Multi-Purpose Canister (MPC)	B 3.1.1-1
3.1.2	SFSC Heat Removal System	B 3.1.2-1
3.1.3	Fuel Cool-Down	B 3.1.3-1
3.1.4	Supplemental Cooling System.....	B 3.1.4-1
3.1.5	Impressed Current Cathodic Protection System.....	B 3.1.5-1
3.2	SFSC RADIATION PROTECTION	B 3.2.1-1
3.2.1	Deleted	
3.2.2	TRANSFER CASK Surface Contamination	B 3.2.2-1
3.2.3	Deleted	
3.3	SFSC CRITICALITY CONTROL	B 3.3.1-1
	Boron Concentration	B 3.3.1-1

HOLTEC INTERNATIONAL COPYRIGHTED MATERIAL

B 3.0 LIMITING CONDITION FOR OPERATION (LCO) APPLICABILITY

BASES

LCOs LCO 3.0.1, 3.0.2, 3.0.4, and 3.0.5 establish the general requirements applicable to all Specifications and apply at all times, unless otherwise stated.

LCO 3.0.1 LCO 3.0.1 establishes the Applicability statement within each individual Specification as the requirement for when the LCO is required to be met (i.e., when the facility is in the specified conditions of the Applicability statement of each Specification).

LCO 3.0.2 LCO 3.0.2 establishes that upon discovery of a failure to meet an LCO, the associated ACTIONS shall be met. The Completion Time of each Required Action for an ACTIONS Condition is applicable from the point in time that an ACTIONS Condition is entered. The Required Actions establish those remedial measures that must be taken within specified Completion Times when the requirements of an LCO are not met. This Specification establishes that:

- a. Completion of the Required Actions within the specified Completion Times constitutes compliance with a Specification; and
- b. Completion of the Required Actions is not required when an LCO is met within the specified Completion Time, unless otherwise specified.

There are two basic types of Required Actions. The first type of Required Action specifies a time limit in which the LCO must be met. This time limit is the Completion Time to restore a system or component or to restore variables to within specified limits. Whether stated as a Required Action or not, correction of the entered Condition is an action that may always be considered upon entering ACTIONS. The second type of Required Action specifies the

(continued)

BASES

LCO 3.0.2
(continued) remedial measures that permit continued operation that is not further restricted by the Completion Time. In this case, compliance with the Required Actions provides an acceptable level of safety for continued operation.

Completing the Required Actions is not required when an LCO is met or is no longer applicable, unless otherwise stated in the individual Specifications.

The Completion Times of the Required Actions are also applicable when a system or component is removed from service intentionally. The reasons for intentionally relying on the ACTIONS include, but are not limited to, performance of Surveillances, preventive maintenance, corrective maintenance, or investigation of operational problems. Entering ACTIONS for these reasons must be done in a manner that does not compromise safety. Intentional entry into ACTIONS should not be made for operational convenience.

LCO 3.0.3 This specification is not applicable to a dry storage cask system because it describes conditions under which a power reactor must be shut down when an LCO is not met and an associated ACTION is not met or provided. The placeholder is retained for consistency with the power reactor technical specifications.

LCO 3.0.4 LCO 3.0.4 establishes limitations on changes in specified conditions in the Applicability when an LCO is not met. It precludes placing the HI-STORM 100 System in a specified condition stated in that Applicability (e.g., Applicability desired to be entered) when the following exist:

- a. Facility conditions are such that the requirements of the LCO would not be met in the Applicability desired to be entered; and
- b. Continued noncompliance with the LCO requirements, if the Applicability were entered, would result in being required to

(continued)

BASES

LCO 3.0.4
(continued)

exit the Applicability desired to be entered to comply with the Required Actions.

Compliance with Required Actions that permit continuing with dry fuel storage activities for an unlimited period of time in a specified condition provides an acceptable level of safety for continued operation. This is without regard to the status of the dry storage system. Therefore, in such cases, entry into a specified condition in the Applicability may be made in accordance with the provisions of the Required Actions. The provisions of this Specification should not be interpreted as endorsing the failure to exercise the good practice of restoring systems or components before entering an associated specified condition in the Applicability.

The provisions of LCO 3.0.4 shall not prevent changes in specified conditions in the Applicability that are required to comply with ACTIONS. In addition, the provisions of LCO 3.0.4 shall not prevent changes in specified conditions in the Applicability that are related to the unloading of an SFSC.

Exceptions to LCO 3.0.4 are stated in the individual Specifications. Exceptions may apply to all the ACTIONS or to a specific Required Action of a Specification.

LCO 3.0.5

LCO 3.0.5 establishes the allowance for restoring equipment to service under administrative controls when it has been removed from service or determined to not meet the LCO to comply with the ACTIONS. The sole purpose of this Specification is to provide an exception to LCO 3.0.2 (e.g., to not comply with the applicable Required Action(s)) to allow the performance of testing to demonstrate:

- a. The equipment being returned to service meets the LCO; or
- b. Other equipment meets the applicable LCOs.

(continued)

BASES

LCO 3.0.5
(continued)

The administrative controls ensure the time the equipment is returned to service in conflict with the requirements of the ACTIONS is limited to the time absolutely necessary to perform the allowed testing. This Specification does not provide time to perform any other preventive or corrective maintenance.

B 3.0 SURVEILLANCE REQUIREMENT (SR) APPLICABILITY

BASES

SRs SR 3.0.1 through SR 3.0.4 establish the general requirements applicable to all Specifications and apply at all times, unless otherwise stated.

SR 3.0.1 SR 3.0.1 establishes the requirement that SRs must be met during the specified conditions in the Applicability for which the requirements of the LCO apply, unless otherwise specified in the individual SRs. This Specification is to ensure that Surveillances are performed to verify that systems and components meet the LCO and variables are within specified limits. Failure to meet a Surveillance within the specified Frequency, in accordance with SR 3.0.2, constitutes a failure to meet an LCO.

Systems and components are assumed to meet the LCO when the associated SRs have been met. Nothing in this Specification, however, is to be construed as implying that systems or components meet the associated LCO when:

- a. The systems or components are known to not meet the LCO, although still meeting the SRs; or
- b. The requirements of the Surveillance(s) are known to be not met between required Surveillance performances.

Surveillances do not have to be performed when the HI-STORM 100 System is in a specified condition for which the requirements of the associated LCO are not applicable, unless otherwise specified.

Surveillances, including Surveillances invoked by Required Actions, do not have to be performed on equipment that has been determined to not meet the LCO because the ACTIONS define the remedial measures that apply. Surveillances have to be met and performed in accordance with SR 3.0.2, prior to returning equipment to service. Upon completion of maintenance, appropriate post-maintenance testing is required. This includes ensuring applicable Surveillances

(continued)

BASES

SR 3.0.1
(continued)

are not failed and their most recent performance is in accordance with SR 3.0.2. Post maintenance testing may not be possible in the current specified conditions in the Applicability due to the necessary dry storage cask system parameters not having been established. In these situations, the equipment may be considered to meet the LCO provided testing has been satisfactorily completed to the extent possible and the equipment is not otherwise believed to be incapable of performing its function. This will allow dry fuel storage activities to proceed to a specified condition where other necessary post maintenance tests can be completed.

SR 3.0.2

SR 3.0.2 establishes the requirements for meeting the specified Frequency for Surveillances and any Required Action with a Completion Time that requires the periodic performance of the Required Action on a "once per..." interval.

SR 3.0.2 permits a 25% extension of the interval specified in the Frequency. This extension facilitates Surveillance scheduling and considers facility conditions that may not be suitable for conducting the Surveillance (e.g., transient conditions or other ongoing Surveillance or maintenance activities).

The 25% extension does not significantly degrade the reliability that results from performing the Surveillance at its specified Frequency. This is based on the recognition that the most probable result of any particular Surveillance being performed is the verification of conformance with the SRs. The exceptions to SR 3.0.2 are those Surveillances for which the 25% extension of the interval specified in the Frequency does not apply. These exceptions are stated in the individual Specifications as a Note in the Frequency stating, "SR 3.0.2 is not applicable."

As stated in SR 3.0.2, the 25% extension also does not apply to the initial portion of a periodic Completion Time that requires performance on a "once per..." basis. The 25% extension applies to each performance after the initial performance. The initial performance of the Required Action, whether it is a particular Surveillance or some other remedial action, is considered a single action with a single Completion Time. One reason for not allowing the 25% extension

(continued)

BASES

HOLTEC INTERNATIONAL COPYRIGHTED MATERIAL

HI-STORM FSAR
REPORT HI-2002444

B 3.0-6

Rev. 0

HI-STORM 100 FSAR, NON-PROPRIETARY
REVISION 12
MARCH 12, 2014

SR 3.0.2
(continued)

to this Completion Time is that such an action usually verifies that no loss of function has occurred by checking the status of redundant or diverse components or accomplishes the function of the affected equipment in an alternative manner.

The provisions of SR 3.0.2 are not intended to be used repeatedly merely as an operational convenience to extend Surveillance intervals or periodic Completion Time intervals beyond those specified.

SR 3.0.3

SR 3.0.3 establishes the flexibility to defer declaring affected equipment as not meeting the LCO or an affected variable outside the specified limits when a Surveillance has not been completed within the specified Frequency. A delay period of up to 24 hours or up to the limit of the specified Frequency, whichever is less, applies from the point in time that it is discovered that the Surveillance has not been performed in accordance with SR 3.0.2, and not at the time that the specified Frequency was not met.

This delay period provides adequate time to complete Surveillances that have been missed. This delay period permits the completion of a Surveillance before complying with Required Actions or other remedial measures that might preclude completion of the Surveillance.

The basis for this delay period includes consideration of HI-STORM 100 System conditions, adequate planning, availability of personnel, the time required to perform the Surveillance, the safety significance of the delay in completing the required Surveillance, and the recognition that the most probable result of any particular Surveillance being performed is the verification of conformance with the requirements. When a Surveillance with a Frequency based not on time intervals, but upon specified facility conditions, is discovered not to have been performed when specified, SR 3.0.3 allows the full delay period of 24 hours to perform the Surveillance.

SR 3.0.3 also provides a time limit for completion of Surveillances that become applicable as a consequence of changes in the specified conditions in the Applicability imposed by the Required Actions.

(continued)

BASES

SR 3.0.3

Failure to comply with specified Frequencies for SRs is expected to

HOLTEC INTERNATIONAL COPYRIGHTED MATERIAL

HI-STORM FSAR
REPORT HI-2002444

B 3.0-7

Rev. 0

HI-STORM 100 FSAR, NON-PROPRIETARY
REVISION 12
MARCH 12, 2014

(continued) be an infrequent occurrence. Use of the delay period established by SR 3.0.3 is a flexibility which is not intended to be used as an operational convenience to extend Surveillance intervals.

If a Surveillance is not completed within the allowed delay period, then the equipment is considered to not meet the LCO or the variable is considered outside the specified limits and the Completion Times of the Required Actions for the applicable LCO Conditions begin immediately upon expiration of the delay period. If a Surveillance is failed within the delay period, then the equipment does not meet the LCO, or the variable is outside the specified limits and the Completion Times of the Required Actions for the applicable LCO Conditions begin immediately upon the failure of the Surveillance.

Completion of the Surveillance within the delay period allowed by this Specification, or within the Completion Time of the ACTIONS, restores compliance with SR 3.0.1.

SR 3.0.4 SR 3.0.4 establishes the requirement that all applicable SRs must be met before entry into a specified condition in the Applicability.

This Specification ensures that system and component requirements and variable limits are met before entry into specified conditions in the Applicability for which these systems and components ensure safe conduct of dry fuel storage activities.

The provisions of this Specification should not be interpreted as endorsing the failure to exercise the good practice of restoring systems or components before entering an associated specified condition in the Applicability.

However, in certain circumstances, failing to meet an SR will not result in SR 3.0.4 restricting a change in specified condition. When a system, subsystem, division, component, device, or variable is

(continued)

BASES

SR 3.0.4
(continued)

outside its specified limits, the associated SR(s) are not required to be performed per SR 3.0.1, which states that Surveillances do not have to be performed on equipment that has been determined to not meet the LCO. When equipment does not meet the LCO, SR 3.0.4 does not apply to the associated SR(s) since the requirement for the SR(s) to be performed is removed. Therefore, failing to perform the Surveillance(s) within the specified Frequency does not result in an SR 3.0.4 restriction to changing specified conditions of the Applicability. However, since the LCO is not met in this instance, LCO 3.0.4 will govern any restrictions that may (or may not) apply to specified condition changes.

The provisions of SR 3.0.4 shall not prevent changes in specified conditions in the Applicability that are required to comply with ACTIONS. In addition, the provisions of LCO 3.0.4 shall not prevent changes in specified conditions in the Applicability that are related to the unloading of an SFSC.

The precise requirements for performance of SRs are specified such that exceptions to SR 3.0.4 are not necessary. The specific time frames and conditions necessary for meeting the SRs are specified in the Frequency, in the Surveillance, or both. This allows performance of Surveillances when the prerequisite condition(s) specified in a Surveillance procedure require entry into the specified condition in the Applicability of the associated LCO prior to the performance or completion of a Surveillance. A Surveillance that could not be performed until after entering the LCO Applicability would have its Frequency specified such that it is not "due" until the specific conditions needed are met. Alternately, the Surveillance may be stated in the form of a Note as not required (to be met or performed) until a particular event, condition, or time has been reached. Further discussion of the specific formats of SRs' annotation is found in Section 1.4, Frequency.

B 3.1 SFSC Integrity

B 3.1.1 Multi-Purpose Canister (MPC)

BASES

BACKGROUND A TRANSFER CASK with an empty MPC is placed in the spent fuel pool and loaded with fuel assemblies meeting the requirements of the CoC. A lid is then placed on the MPC. The TRANSFER CASK and MPC are raised to the top of the spent fuel pool surface. The TRANSFER CASK and MPC are then moved into the cask preparation area where the MPC lid is welded to the MPC shell and the welds are inspected and tested. The water is drained from the MPC cavity and drying is performed. The MPC cavity is backfilled with helium. Then, the MPC vent and drain port cover plates and closure ring are installed and welded. Inspections are performed on the welds. MPC cavity moisture removal using vacuum drying or forced helium dehydration is performed to remove residual moisture from the MPC cavity space after the MPC has been drained of water. If vacuum drying is used, any water that has not drained from the fuel cavity evaporates from the fuel cavity due to the vacuum. This is aided by the temperature increase due to the decay heat of the fuel and by the heat added to the MPC from the optional warming pad, if used.

If forced helium dehydration is used, the dry gas introduced to the MPC cavity through the vent or drain port absorbs the residual moisture in the MPC. This humidified gas exits the MPC via the other port and the absorbed water is removed through condensation and/or mechanical drying. The dried helium is then forced back to the MPC until the temperature acceptance limit is met.

After the completion of drying, the MPC cavity is backfilled with helium meeting the requirements of the CoC.

(continued)

BASES

BACKGROUND
(continued)

Backfilling of the MPC fuel cavity with helium promotes gaseous heat dissipation and the inert atmosphere protects the fuel cladding. Backfilling the MPC with helium in the required quantity eliminates air inleakage over the life of the MPC because the cavity pressure rises due to heat up of the confined gas by the fuel decay heat during storage.

**APPLICABLE
SAFETY
ANALYSIS**

The confinement of radioactivity during the storage of spent fuel in the MPC is ensured by the multiple confinement boundaries and systems. The barriers relied on are the fuel pellet matrix, the metallic fuel cladding tubes in which the fuel pellets are contained, and the MPC in which the fuel assemblies are stored. Long-term integrity of the fuel and cladding depend on storage in an inert atmosphere. This is accomplished by removing water from the MPC and backfilling the cavity with an inert gas. The thermal analyses of the MPC assume that the MPC cavity is filled with dry helium of a minimum quantity to ensure the assumptions used for convection heat transfer are preserved. Keeping the backfill pressure below the maximum value preserves the initial condition assumptions made in the MPC overpressurization evaluation.

(continued)

BASES (continued)

LCO A dry, helium filled and sealed MPC establishes an inert heat removal environment necessary to ensure the integrity of the multiple confinement boundaries. Moreover, it also ensures that there will be no air in-leakage into the MPC cavity that could damage the fuel cladding over the storage period.

APPLICABILITY The dry, sealed and inert atmosphere is required to be in place during TRANSPORT OPERATIONS and STORAGE OPERATIONS to ensure both the confinement barriers and heat removal mechanisms are in place during these operating periods. These conditions are not required during LOADING OPERATIONS or UNLOADING OPERATIONS as these conditions are being established or removed, respectively during these periods in support of other activities being performed with the stored fuel.

ACTIONS A note has been added to the ACTIONS which states that, for this LCO, separate Condition entry is allowed for each MPC. This is acceptable since the Required Actions for each Condition provide appropriate compensatory measures for each MPC not meeting the LCO. Subsequent MPCs that do not meet the LCO are governed by subsequent Condition entry and application of associated Required Actions.

A.1

If the cavity vacuum drying pressure or demoinsturizer exit gas temperature limit has been determined not to be met during TRANSPORT OPERATIONS or STORAGE OPERATIONS, an engineering evaluation is necessary to determine the potential quantity of moisture left within the MPC cavity. Since moisture remaining in the cavity during these modes of operation may represent a long-term degradation concern, immediate action is not necessary. The Completion Time is sufficient to complete the engineering evaluation commensurate with the safety significance of the CONDITION.

(continued)

BASES

ACTIONS
(continued)

A.2

Once the quantity of moisture potentially left in the MPC cavity is determined, a corrective action plan shall be developed and actions initiated to the extent necessary to return the MPC to an analyzed condition. Since the quantity of moisture estimated under Required Action A.1 can range over a broad scale, different recovery strategies may be necessary. Since moisture remaining in the cavity during these modes of operation may represent a long-term degradation concern, immediate action is not necessary. The Completion Time is sufficient to develop and initiate the corrective actions commensurate with the safety significance of the CONDITION.

B.1

If the MPC cavity vacuum drying acceptance criterion is not met during the allowable time, the Required Action ensures a sufficient quantity of helium within the MPC cavity to provide additional margin to the PCT limits. The Completion Time is sufficient to complete the corrective action commensurate with the safety significance of the CONDITION.

(continued)

BASES

ACTIONS
(continued)

C.1

If the helium backfill quantity limit has been determined not to be met during TRANSPORT OPERATIONS or STORAGE OPERATIONS, an engineering evaluation is necessary to determine the quantity of helium within the MPC cavity. Since too much or too little helium in the MPC during these modes represents a potential overpressure or heat removal degradation concern, an engineering evaluation shall be performed in a timely manner. The Completion Time is sufficient to complete the engineering evaluation commensurate with the safety significance of the CONDITION.

C.2

Once the quantity of helium in the MPC cavity is determined, a corrective action plan shall be developed and initiated to the extent necessary to return the MPC to an analyzed condition either by adding or removing helium or by demonstrating through analysis that all cask system limits will continue to be met. Since the quantity of helium estimated under Required Action C.1 can range over a broad scale, different recovery strategies may be necessary. Since elevated or reduced helium quantities existing in the MPC cavity represent a potential overpressure or heat removal degradation concern, corrective actions should be developed and implemented in a timely manner. The Completion Time is sufficient to develop and initiate the corrective actions commensurate with the safety significance of the CONDITION.

(continued)

BASES

ACTIONS
(continued)

D.1

If the helium leak rate limit has been determined not to be met during TRANSPORT OPERATIONS or STORAGE OPERATIONS, an engineering evaluation is necessary to determine the impact of increased helium leak rate on heat removal and off-site dose. Since the HI-STORM OVERPACK is a ventilated system, any leakage from the MPC is transported directly to the environment. Since an increased helium leak rate represents a potential challenge to MPC heat removal and the off-site doses, reasonably rapid action is warranted. The Completion Time is sufficient to complete the engineering evaluation commensurate with the safety significance of the CONDITION.

D.2

Once the consequences of the elevated leak rate from the MPC are determined, a corrective action plan shall be developed and initiated to the extent necessary to return the MPC to an analyzed condition. Since the recovery mechanisms can range over a broad scale based on the evaluation performed under Required Action C.1, different recovery strategies may be necessary. Since an elevated helium leak rate represents a challenge to heat removal rates and offsite doses, reasonably rapid action is required. The Completion Time is sufficient to develop and initiate the corrective actions commensurate with the safety significance of the CONDITION.

(continued)

BASES

ACTIONS
(continued)

E.1

If the MPC fuel cavity cannot be successfully returned to a safe, analyzed condition, the fuel must be placed in a safe condition in the spent fuel pool. The Completion Time is reasonable based on the time required to replace the transfer lid with the pool lid (if required), perform fuel cooldown operations (if required), re-flood the MPC, cut the MPC lid welds, move the TRANSFER CASK into the spent fuel pool, remove the MPC lid, and remove the spent fuel assemblies in an orderly manner and without challenging personnel.

BASES

SURVEILLANCE REQUIREMENTS SR 3.1.1.1 , SR 3.1.1.2, and SR 3.1.1.3

The long-term integrity of the stored fuel is dependent on storage in a dry, inert environment. For moderate burnup fuel cavity dryness may be demonstrated either by evacuating the cavity to a very low absolute pressure and verifying that the pressure is held over a specified period of time or by recirculating dry helium through the MPC cavity to absorb moisture until the gas temperature or dew point at the specified location reaches and remains below the acceptance limit for the specified time period. A low vacuum pressure or a demister exit temperature meeting the acceptance limit is an indication that the cavity is dry. For high burnup fuel and high decay heat load MPCs, the forced helium dehydration method of moisture removal must be used to provide necessary cooling of the fuel during drying operations. Cooling provided by normal operation of the forced helium dehydration system ensures that the fuel cladding temperature remains below the applicable limits since forced recirculation of helium provides more effective heat transfer than that which occurs during normal storage operations.

Table 3-1 of Appendix A to the CoC provides the appropriate requirements for drying the MPC cavity based on the burnup class of the fuel (moderate or high) and the applicable short-term temperature limit. The temperature limits and associated cladding hoop stress calculation requirements are consistent with the guidance in NRC Interim Staff Guidance (ISG) Document 11.

Having the proper quantity of helium in the MPC ensures adequate heat transfer from the fuel to the fuel basket and surrounding structure of the MPC and precludes any overpressure event from challenging the normal, off-normal, or accident design pressure of the MPC.

Meeting the helium leak rate limit ensures there is adequate helium in the MPC for long term storage and that there is no credible effluent dose from the cask.

(continued)

B 3.1 SFSC Integrity

B 3.1.2 SFSC Heat Removal System

BASES

BACKGROUND The SFSC Heat Removal System is a passive, air-cooled, convective heat transfer system that ensures heat from the MPC canister is transferred to the environs by the chimney effect. Relatively cool air is drawn into the annulus between the OVERPACK and the MPC through the air inlets. The MPC transfers its heat from the canister surface to the air via natural convection. The buoyancy created by the heating of the air creates a chimney effect and the air is forced back into the environs through the outlet air ducts at the top of the OVERPACK.

APPLICABLE SAFETY ANALYSIS The thermal analyses of the SFSC take credit for the decay heat from the spent fuel assemblies being ultimately transferred to the ambient environment surrounding the OVERPACK. Transfer of heat away from the fuel assemblies ensures that the fuel cladding and other SFSC component temperatures do not exceed applicable limits. Under normal storage conditions, the air inlets are unobstructed and full air flow (i.e., maximum heat transfer for the given ambient temperature) occurs.

Analyses have been performed for the half and complete obstruction of all the air inlets. Blockage of half of the air inlets reduces air flow through the OVERPACK annulus and decreases heat transfer from the MPC. Under this off-normal condition, no SFSC components exceed the short term temperature limits.

(continued)

BASES

**APPLICABLE
SAFETY
ANALYSIS**

The complete blockage of all air inlets stops normal (continued) air cooling of the MPC. The MPC will continue to radiate heat to the relatively cooler OVERPACK. With the loss of normal air cooling, the SFSC component temperatures will increase toward their respective short-term temperature limits. None of the components reach their temperature limits over the duration of the analyzed event.

LCO

The SFSC Heat Removal System must be verified to be operable to preserve the assumptions of the thermal analyses. Operability is defined as at least 50% of the inlet and outlet air ducts are available for air flow (i.e., unblocked). Operability of the heat removal system ensures that the decay heat generated by the stored fuel assemblies is transferred to the environs at a sufficient rate to maintain fuel cladding and other SFSC component temperatures within design limits.

The intent of this LCO is to address those occurrences of air duct blockage that can be reasonably anticipated to occur from time to time at the ISFSI (i.e., Design Event I and II class events per ANSI/ANS-57.9). These events are of the type where corrective actions can usually be accomplished within one 8-hour operating shift to restore the heat removal system to operable status (e.g., removal of loose debris).

(continued)

BASES

LCO

(continued)

This LCO is not intended to address low frequency, unexpected Design Event III and IV class events such as design basis accidents and extreme environmental phenomena that could potentially block one or more of the air ducts for an extended period of time (i.e., longer than the total Completion Time of the LCO). This class of events is addressed site-specifically as required by Section 3.4.9 of Appendix B to the CoC.

APPLICABILITY

The LCO is applicable during STORAGE OPERATIONS. Once an OVERPACK containing an MPC loaded with spent fuel has been placed into its storage configuration, the heat removal system must be operable to ensure adequate dissipation of the decay heat from the fuel assemblies.

ACTIONS

A note has been added to the ACTIONS which states that, for this LCO, separate Condition entry is allowed for each SFSC. This is acceptable since the Required Actions for each Condition provide appropriate compensatory measures for each SFSC not meeting the LCO. Subsequent SFSCs that don't meet the LCO are governed by subsequent Condition entry and application of associated Required Actions.

A.1

Although the heat removal system remains operable, the blockage should be cleared expeditiously.

B.1

If the heat removal system has been determined to be inoperable, it must be restored to operable status within eight hours. Eight hours is a reasonable period of time (typically, one operating shift) to take action to remove the obstructions in the air flow path.

(continued)

BASES

ACTIONS
(continued)

C.1

If the heat removal system cannot be restored to operable status within eight hours, the innermost portion of the OVERPACK concrete may experience elevated temperatures. Therefore, dose rates are required to be measured to verify the effectiveness of the radiation shielding provided by the concrete. This Action must be performed immediately and repeated every twelve hours thereafter to provide timely and continued evaluation of the effectiveness of the concrete shielding. As necessary, the cask user shall provide additional radiation protection measures such as temporary shielding. The Completion Time is reasonable considering the expected slow rate of deterioration, if any, of the concrete under elevated temperatures.

C.2.1

In addition to Required Action C.1, efforts must continue to restore cooling to the SFSC. Efforts must continue to restore the heat removal system to operable status by removing the air flow obstruction(s) unless optional Required Action C.2.2 is being implemented.

This Required Action must be complete in 64 hours for an aboveground system with an MPC decay heat load of 28.74 kW or less, in 24 hours for an aboveground system with an MPC decay heat load greater than 28.74 kW, and in 16 hours for an underground system. These Completion Times are consistent with the thermal analyses of this event, which show that all component temperatures remain below their short-term temperature limits up to 72, 32 or 24 hours after event initiation, respectively.

(continued)

BASES

ACTIONS

C.2.1 (continued)

The Completion Time reflects the 8 hours to complete Required Action B.1 and the appropriate balance of time consistent with the applicable analysis results. The event is assumed to begin at the time the SFSC heat removal system is declared inoperable. This is reasonable considering the low probability of all air ducts becoming simultaneously blocked by trash or debris.

C.2.2

In lieu of implementing Required Action C.2.1, transfer of the MPC into a TRANSFER CASK will place the MPC in an analyzed condition and ensure adequate fuel cooling until actions to correct the heat removal system inoperability can be completed. Transfer of the MPC into a TRANSFER CASK removes the SFSC from the LCO Applicability since STORAGE OPERATIONS does not include times when the MPC resides in the TRANSFER CASK. In this case, the requirements of CoC Appendix A, LCO 3.1.4 apply.

An engineering evaluation must be performed to determine if any concrete deterioration has occurred which prevents it from performing its design function. If the evaluation is successful and the air flow obstructions have been cleared, the OVERPACK heat removal system may be considered operable and the MPC transferred back into the OVERPACK. Compliance with LCO 3.1.2 is then restored. If the evaluation is unsuccessful, the user must transfer the MPC into a different, fully qualified OVERPACK to resume STORAGE OPERATIONS and restore compliance with LCO 3.1.2

(continued)

BASES

ACTIONS

C.2.2 (continued)

In lieu of performing the engineering evaluation, the user may opt to proceed directly to transferring the MPC into a different, fully qualified OVERPACK or place the TRANSFER CASK in the spent fuel pool and unload the MPC.

The Completion Times of 64, 24 and 16 hours reflect the Completion Time from Required Action C.2.1 to ensure component temperatures remain below their short-term temperature limits for the respective decay heat loads and OVERPACK styles.

SURVEILLANCE
REQUIREMENTS

SR 3.1.2

The long-term integrity of the stored fuel is dependent on the ability of the SFSC to reject heat from the MPC to the environment. There are two options for implementing SR 3.1.2, either of which is acceptable for demonstrating that the heat removal system is OPERABLE.

Visual observation that all air inlets and outlets are unobstructed ensures that air flow past the MPC is occurring and heat transfer is taking place. Greater than 50% blockage of the total air inlet area or air outlet area renders the heat removal system inoperable and this LCO is not met. 50% or less blockage of the total air inlet area or air outlet area does not constitute inoperability of the heat removal system. However, corrective actions should be taken promptly to remove the obstruction and restore full flow through the affected air duct(s).

(continued)

BASES

SURVEILLANCE REQUIREMENTS SR 3.1.2 (continued)

As an alternative, for OVERPACKs with air temperature monitoring instrumentation installed in the air outlets, the temperature rise between ambient and the OVERPACK air outlet may be monitored to verify operability of the heat removal system. Blocked air ducts will reduce air flow and increase the temperature rise experienced by the air as it removes heat from the MPC. Based on the analyses, provided the air temperature rise is less than the limit stated in the SR, adequate air flow and, therefore, adequate heat transfer is occurring to provide assurance of long term fuel cladding integrity. The reference ambient temperature used to perform this Surveillance shall be measured at the ISFSI facility.

The Frequency of 24 hours for aboveground systems and 16 hours for underground systems is reasonable based on the time necessary for SFSC components to heat up to unacceptable temperatures assuming design basis heat loads, and allowing for corrective actions to take place upon discovery of blockage of air ducts.

-
- REFERENCES**
1. FSAR Chapter 4
 2. FSAR Sections 11.2.13 and 11.2.14
 3. ANSI/ANS 57.9-1992
-

B 3.1 SFSC INTEGRITY

B 3.1.3 MPC Cavity Reflooding

BASES

BACKGROUND In the event that an MPC must be unloaded, the TRANSFER CASK with its enclosed MPC is returned to the cask preparation area to begin the process of fuel unloading. The MPC closure ring, and vent and drain port cover plates are removed. The MPC gas is sampled to determine the integrity of the spent fuel cladding. The pressure in the MPC cavity is ensured to be less than the 100 psig design pressure. This is accomplished via direct measurement of the MPC gas pressure or via analysis.

After ensuring the MPC cavity pressure meets the LCO limit, the MPC is then re-flooded with water at a controlled rate and/or the pressure monitored to ensure that the pressure remains below 100 psig. Once the cavity is filled with water, the MPC lid weld is removed leaving the MPC lid in place. The transfer cask and MPC are placed in the spent fuel pool and the MPC lid is removed. The fuel assemblies are removed from the MPC and the MPC and transfer cask are removed from the spent fuel pool and decontaminated.

(continued)

BASES (continued)

BACKGROUND (continued) Ensuring that the MPC cavity pressure is less than the LCO limit ensures that any steam produced within the cavity is safely vented to an appropriate location and eliminates the risk of high MPC pressure due to sudden generation of large steam quantities during re-flooding.

APPLICABLE SAFETY ANALYSIS The confinement of radioactivity during the storage of spent fuel in the MPC is ensured by the multiple confinement boundaries and systems. The barriers relied on are the fuel pellet matrix, the metallic fuel cladding tubes in which the fuel pellets are contained, and the MPC in which the fuel assemblies are stored. Standard practice in the dry cask industry has historically been to directly reflood the cask with water. This standard practice is known not to induce fuel cladding failures.

The integrity of the MPC depends on maintaining the internal cavity pressures within design limits. This is accomplished by introducing water to the cavity in a controlled manner such that there is no sudden formation of large quantities of steam during MPC re-flooding. (Ref. 1).

LCO Determining the MPC cavity pressure prior to and during re-flooding ensures that there will be sufficient venting of any steam produced to avoid excessive MPC pressurization.

APPLICABILITY The MPC cavity pressure is controlled during UNLOADING OPERATIONS after the transfer cask and integral MPC are back in the FUEL BUILDING and are no longer suspended from, or secured in, the transporter. Therefore, the Cask Reflood LCO does not apply during TRANSPORT OPERATIONS and STORAGE OPERATIONS.

A note has been added to the APPLICABILITY for LCO 3.1.3 which states that the LCO is only applicable during wet UNLOADING OPERATIONS. This is acceptable since the intent of the LCO is to avoid uncontrolled MPC pressurization due to water flashing during re-flooding operations. This is not a concern for dry UNLOADING OPERATIONS.

(continued)

BASES (continued)

ACTIONS

A note has been added to the ACTIONS which states that, for this LCO, separate Condition entry is allowed for each MPC. This is acceptable since the Required Actions for each Condition provide appropriate compensatory measures for each MPC not meeting the LCO. Subsequent MPCs that do not meet the LCO are governed by subsequent Condition entry and application of associated Required Actions.

A.1 and A.2

If the MPC cavity pressure limit is not met, actions must be taken to restore the parameters to within the limits before initiating or continuing re-flooding the MPC.

Immediately is an appropriate Completion Time because it requires action to be initiated promptly and completed without delay, but does not establish any particular fixed time limit for completing the action. This offers the flexibility necessary for users to plan and implement any necessary work activities commensurate with the safety significance of the condition, which is governed by the MPC heat load.

(continued)

BASES (continued)

**SURVEILLANCE
REQUIREMENTS**

SR 3.1.3.1

The integrity of the MPC is dependent on controlling the internal MPC pressure. By controlling the MPC internal pressure prior to and during re-flooding the MPC there is sufficient steam venting capacity during MPC re-flooding.

The LCO must be met on each SFSC before the initiation of MPC re-flooding operations to ensure the design and analysis basis are preserved. If the re-flood rate is limited to the bounding value given in FSAR Section 4.5 or calculated specifically for the MPC heat load then the MPC pressure must only be verified once prior to the re-flood.

If verifying the MPC pressure using direct measurement only the SR requires checks prior to the re-flood and every hour during re-flood. The direct measurement schedule is sufficient to prevent overpressurization of the MPC cavity as the rate of pressure rise is relatively slow compared to increase in re-flood rate.

REFERENCES

1. FSAR, Section 4.5, 8.3.2 and 8.3.3.
-

B 3.1 SFSC Integrity

B 3.1.4 Supplemental Cooling System

BASES

BACKGROUND The Supplemental Cooling System (SCS) is an active cooling system that provides augmented heat removal from the MPC to ensure fuel cladding temperatures remain below the applicable limit during onsite transport operations in the TRANSFER CASK. The system is required for all MPCs meeting the burnup, heat load, and TRANSFER CASK orientation combinations specified in the Applicability of the LCO.

**APPLICABLE
SAFETY
ANALYSIS**

For MPCs containing all moderate burnup fuel ($\leq 45,000$ MWD/MTU), SCS operation is not required, because the fuel cladding temperature does not exceed the limit of 1058°F for moderate burnup fuel (Refs. 1, 2, and 3).

For MPC-68M containing high burnup fuel ($>45,000$ MWD/MTU) up to design basis heat load, SCS operation is not required because the fuel cladding temperature does not exceed the limit of 752°F for high burnup fuel (Refs. 1, 2, and 3).

(continued)

BASES

LCO The Supplemental Cooling System must be operable if the MPC/TRANSFER cask assemblage meets one of the following conditions in the Applicability portion of the LCO in order to preserve the assumptions made in the thermal analysis.

APPLICABILITY This LCO is not applicable to MPC-68M.

The LCO is applicable within 4 hours after completion of MPC drying operations in accordance with LCO 3.1.1 or within 4 hours of transferring the MPC into the TRANSFER CASK if the MPC is to be unloaded, and the following conditions are met:

MPCs having one or more fuel assemblies with an average burnup greater than 45,000 MWD/MTU and either (i) MPC backfilled to higher helium backfill limits in Table 3-2 of Technical Specification Appendix B and having decay heat greater than 90% of the design basis heat load defined in Subsection 2.1.9.1 or (ii) MPC backfilled to lower helium backfill limits in Table 3-2 and having decay heat greater than 90% of heat load limits in Tables 3-3 or 3-4 of Tech. Spec. Appendix A.

ACTIONS A.1

If the SCS has been determined to be inoperable, the thermal analysis shows that the fuel cladding temperature would not exceed the short term temperature limit applicable to an off-normal condition, even with no water in the TRANSFER CASK-to-MPC annulus. Actions should be taken to restore the SCS to operable status in a timely manner. Because the thermal analysis is a steady-state analysis, there is an indefinite period of time available to make repairs to the SCS. However, it is prudent to require the actions to be completed in a reasonably short period of time. A Completion Time of 7 days is considered appropriate and a reasonable amount of time to plan the work, obtain needed parts, and execute the work in a controlled manner.

(continued)

BASES

ACTIONS
(continued)

B.1

If, after 7 days, the SCS cannot be restored to operable status, actions should be taken to remove the fuel assemblies from the MPC and place them back into the spent fuel pool storage racks. Thirty days is considered a reasonable time frame given that the MPC will be adequately cooled while this action is being planned and implemented, and certain equipment for this infrequent evolution (e.g., weld cutting machine) may take some time to acquire.

SURVEILLANCE
REQUIREMENTS SR 3.1.4.1

The long-term integrity of the stored fuel is dependent on the ability of the SFSC to reject heat from the MPC to the environment, including during short-term evolutions such as on-site transportation in the TRANSFER CASK. The SCS is required to ensure adequate fuel cooling in certain cases. The SCS should be verified to be operable every two hours. This would involve verification that the coolant temperatures are within the design limits defined in Appendix 2.C. This is a reasonable Frequency given the typical oversight occurring during the on-site transportation evolution, the duration of the evolution, and the simple equipment involved.

AMBIENT TEMPERATURE REQUIREMENTS

Cask users are required in accordance with Design Features section in Tech. Specs. Appendix B to evaluate three day average ambient temperatures for compliance with FSAR Table 2.2.2 temperature limits under HI-TRAC transfer operations inside the part 50 structural boundary and outside of it. The three day average temperatures maybe computed from best available site data or based on local weather forecasts during scheduled periods of HI-TRAC movement or a suitably conservative method for bounding the three day average.

HOLTEC INTERNATIONAL COPYRIGHTED INFORMATION

HI-STORM FSAR
REPORT HI-2002444

B 3.1.4-3

Rev. 12

- REFERENCES
1. FSAR Sections 4.5 and 4.III.5
 2. NRC Interim Staff Guidance 11, Rev. 3
 3. NRC Memorandum, C. Brown to M.W. Hodges, January 29, 2004
-

HOLTEC INTERNATIONAL COPYRIGHTED INFORMATION

HI-STORM FSAR
REPORT HI-2002444

B.3.1.4-4

Rev. 12

B 3.1 SFSC Integrity

B 3.1.5 Impressed Current Cathodic Protection System (ICCPS)

BASES

BACKGROUND The Impressed Current Cathodic Protection System (ICCPS) is an active corrosion mitigating system, which uses anodes plus a source of electric current that is forced to flow from the anodes to the Cavity Enclosure Container (CEC) to oppose corrosion currents. The user may elect to either extend an existing ICCPS to protect the installed ISFSI or establish an autonomous ICCPS. The ICCPS is designed on a site-specific basis for a particular ISFSI installation in accordance with the design criteria established in FSAR Supplement 3.I, Subsection 3.I.4.1.

APPLICABLE SAFETY ANALYSIS The ICCPS provides reasonable assurance that corrosion will not promote degradation of the CEC Container Shell and Bottom Plate to the extent of challenging its structural function or initiate through-wall in-leakage of water into the storage cavity.

The ICCPS is required for all HI-STORM 100U VVM's that are installed in environments with aggressive corrosivity. FSAR Supplement 3.I, Subsection 3.I.4.1 provides the design criteria for an ICCPS and more details on the evaluation procedure to determine if the environment corrosivity is mild or aggressive.

The ICCPS is classified as an interfacing System, Structure or Component (SSC) to the HI-STORM 100U VVM and is designated as not important- to- safety. The ICCPS is not required to maintain subcriticality, control radiation doses to workers and public, assure fuel retrievability or maintain the confinement barrier.

(continued)

BASES

LCO Although corrosion is expected to be a generally slow process even in the majority of subterranean environments determined to have aggressive corrosivity, the ICCPS will ensure corrosion will be kept to a minimum for the duration of storage operations. In order to be effective at mitigating degradation of the CEC due to corrosion, the ICCPS must be operable as soon as practicable after installation of the first HI-STORM 100U VVM and remain operable as much as practicable during storage operations.

APPLICABILITY The LCO is applicable during STORAGE OPERATIONS. Once the first VVM to be protected by a particular ICCPS is installed the ICCPS must remain operable at all times to the extent practicable.

ACTIONS A.1

If the ICCPS has been determined to be inoperable, Actions should be taken to restore the ICCPS to operable status in a timely manner. Because corrosion is an intrinsically slow process, there is sufficient time available to perform repairs and other corrective actions. However, it is prudent to require the actions to be completed in a reasonably short period of time. A Completion Time of 6 months is considered appropriate and a reasonable amount of time to plan the work, obtain needed parts, and execute the work.

(continued)

BASES

ACTIONS
(continued)

A.2

In lieu of Action A.1, the user may opt to perform an engineering evaluation to establish reasonable assurance that CEC Container Shells and Bottom Plate are maintaining adequate integrity and have adequate corrosion reserve for continued storage operation for at least four more years or until the expiration of the license, whichever comes first. This action may include a more detailed review of the subterranean environment corrosivity, experience with corrosion of other buried systems at the site, past performance of the ICCPS and/or thickness measurements (e.g. ultrasonic inspection) of selected CEC Container Shells and Bottom Plates. Because corrosion is generally a slow process, there is sufficient time available to perform the engineering evaluation. In addition, the engineering evaluation if successful provides reasonable assurance that the CEC is experiencing minimal corrosion and will continue to perform its primary function during storage operations. However, it is prudent to require the actions to be completed in a reasonably short period of time. A Completion Time of 1 year is considered appropriate and reasonable.

(continued)

BASES

ACTIONS
(continued)

B.1

If after 8 years the ICCPS has been determined to be operable for less than 70% of the time since initial startup, Actions should be taken to establish reasonable assurance that CEC Container Shells and Bottom Plates are maintaining adequate integrity and have adequate corrosion reserve for continued storage operation of at least three more years or until the expiration of the license, whichever comes first. This action may include a more detailed review of the subterranean environment corrosivity, experience with corrosion of other buried systems at the site, past performance of the ICCPS and/or thickness measurements (e.g. ultrasonic inspection) of selected CEC Container Shells and Bottom Plates. Because corrosion is generally a slow process, there is sufficient time available to perform the engineering evaluation. In addition, the engineering evaluation, if successful, provides reasonable assurance that the CEC is experiencing minimal corrosion and will continue to perform its primary function during storage operations. However, it is prudent to require the actions to be completed in a reasonably short period of time. A Completion Time of 1 year is considered appropriate and a reasonable amount of time to perform the Action. A 70% operable status is determined by engineering judgment to be the minimum duration of cathodic protection that will provide reasonable assurance the CEC will maintain its integrity during storage operations.

(continued)

BASES

ACTIONS
(continued)

B.2

If an engineering evaluation does not establish adequate integrity of the CEC Container Shells and Bottom Plates, Actions should be taken to re-establish their integrity. This may entail performing thickness measurements (e.g. ultrasonic inspections) and repair of CEC components. Welding repairs require the transfer of the MPC into a transfer cask. Other types of repairs shall be evaluated to determine whether removal of the MPC from the VVM is necessary. Repairs with the potential to adversely affect safety functions shall be evaluated to ensure system functionality is maintained. If reasonable assurance is provided that the integrity of the CEC Container Shell and Bottom Plate has been adequately re-established, the initial start-up period shall be reset. Because corrosion is generally a slow process, there is sufficient time available to perform repairs. However, it is prudent to require the actions to be completed in a reasonably short period of time. A Completion Time of 3 years ensures that there is sufficient time to perform the Action.

C.1

If an engineering evaluation cannot conclude adequate integrity of the CEC Container Shells and Bottom Plates or if repairs are not performed to re-establish integrity, Actions should be taken to transfer the MPC's from affected VVM's to unaffected VVM's or other approved and compatible casks. Because corrosion is generally a slow process there is sufficient time available to perform the MPC transfers, including supply of additional storage casks and storage pad(s) if needed. A Completion Time of 3 years is considered appropriate and a reasonable amount of time to perform the Action.

**SURVEILLANCE
REQUIREMENTS** SR 3.1.5.1

The long-term integrity of the CEC Container Shell and Bottom Plate is dependent on the ability of the ICCPS to cathodically protect all surfaces contacting the subgrade. The ICCPS should be verified to be operable one year after installation of the first VVM and every month thereafter. This may involve verification that the current and voltage requirements are in accordance with the site-specific design as well as ensuring that rectifiers are in working order. The surveillance intervals follow the guidance provided in the standards and publications listed in the design criteria provided in FSAR Supplement 3.I, Subsection 3.I.4.1. This is a reasonable Frequency given the generally slow process of corrosion. This surveillance is suspended for 1 year if Action A.2 is met.

SR 3.1.5.2

The long-term integrity of the CEC container shell and Bottom Plate is dependent on the ability of the ICCPS to cathodically protect all surfaces contacting the subgrade. The ICCPS should be verified to be operable for at least 70% of the time on a cumulative basis between 8 and 10 years after initial startup (whether or not initial startup was successful) to allow sufficient operating history. This verification will involve review of records that support the operable status of the ICCPS, which may include review of current and voltage measurements, and other site-specific design data. The surveillance intervals follow the guidance of engineering judgment. This is a reasonable Frequency given the generally slow process of corrosion.

REFERENCES 1. FSAR Supplement 3.I, Subsection 3.I.4.1

Deleted
B 3.2.1

B 3.2 SFSC Radiation Protection

B 3.2.1 Deleted

HOLTEC INTERNATIONAL COPYRIGHTED INFORMATION

HI-STORM FSAR
REPORT HI-2002444

B 3.2.1-1

Rev. 7

HI-STORM 100 FSAR, NON-PROPRIETARY
REVISION 12
MARCH 12, 2014

B 3.2 SFSC Radiation Protection

B 3.2.2 TRANSFER CASK Surface Contamination

BASES

BACKGROUND A TRANSFER CASK is immersed in the spent fuel pool in order to load the spent fuel assemblies. As a result, the surface of the TRANSFER CASK may become contaminated with the radioactive material in the spent fuel pool water. This contamination is removed prior to moving the TRANSFER CASK to the ISFSI, or prior to transferring the MPC into the OVERPACK, whichever occurs first, in order to minimize the radioactive contamination to personnel or the environment. This allows dry fuel storage activities to proceed without additional radiological controls to prevent the spread of contamination and reduces personnel dose due to the spread of loose contamination or airborne contamination. This is consistent with ALARA practices.

APPLICABLE SAFETY ANALYSIS The radiation protection measures implemented during MPC transfer and transportation using the TRANSFER CASK are based on the assumption that the exterior surfaces of the TRANSFER CASKS have been decontaminated. Failure to decontaminate the surfaces of the TRANSFER CASKS could lead to higher-than-projected occupational doses.

LCO Removable surface contamination on the TRANSFER CASK exterior surfaces and accessible surfaces of the MPC is limited to 1000 dpm/100 cm² from beta and gamma sources and 20 dpm/100 cm² from alpha sources. These limits are taken from the guidance in IE Circular 81-07 (Ref. 2) and are based on the minimum level of activity that can be routinely detected under a surface contamination control program using direct survey methods. Only loose contamination is controlled, as fixed contamination will not result from the TRANSFER CASK loading process.

(continued)

BASES

LCO
(continued)

Experience has shown that these limits are low enough to prevent the spread of contamination to clean areas and are significantly less than the levels which would cause significant personnel skin dose. LCO 3.2.2 requires removable contamination to be within the specified limits for the exterior surfaces of the TRANSFER CASK and accessible portions of the MPC. The location and number of surface swipes used to determine compliance with this LCO are determined based on standard industry practice and the user's plant-specific contamination measurement program for objects of this size. Accessible portions of the MPC means the upper portion of the MPC external shell wall accessible after the inflatable annulus seal is removed and before the annulus shield ring is installed. The user shall determine a reasonable number and location of swipes for the accessible portion of the MPC. The objective is to determine a removable contamination value representative of the entire upper circumference of the MPC, while implementing sound ALARA practices.

APPLICABILITY

The applicability is modified by a note that states that the LCO is not applicable to the TRANSFER CASK if MPC transfer operations occur inside the FUEL BUILDING. This is consistent with the intent of this LCO, which is to ensure loose contamination on the loaded TRANSFER CASK and MPC outside the FUEL BUILDING is within limits. If the MPC transfer is performed inside the FUEL BUILDING the empty TRANSFER CASK remains behind and is treated like any other contaminated hardware under the user's Part 50 contamination control program.

Verification that the surface contamination is less than the LCO limit is performed during LOADING OPERATIONS. This occurs before TRANSPORT OPERATIONS, when the LCO is applicable. Measurement of surface contamination is unnecessary during UNLOADING OPERATIONS as surface contamination would have been measured prior to moving the subject TRANSFER CASK to the ISFSI.

(continued)

HOLTEC INTERNATIONAL COPYRIGHTED MATERIAL

HI-STORM FSAR
REPORT HI-2002444

B 3.2.2-2

Rev. 1

BASES (continued)

ACTIONS A note has been added to the ACTIONS which states that, for this LCO, separate Condition entry is allowed for each TRANSFER CASK. This is acceptable since the Required Actions for each Condition provide appropriate compensatory measures for each TRANSFER CASK not meeting the LCO. Subsequent TRANSFER CASKs that do not meet the LCO are governed by subsequent Condition entry and application of associated Required Actions.

A.1

If the removable surface contamination of a TRANSFER CASK or MPC, as applicable, that has been loaded with spent fuel is not within the LCO limits, action must be initiated to decontaminate the TRANSFER CASK or MPC and bring the removable surface contamination within limits. The Completion Time of 7 days is appropriate given that sufficient time is needed to prepare for, and complete the decontamination once the LCO is determined not to be met.

SURVEILLANCE REQUIREMENTS SR 3.2.2.1

This SR verifies that the removable surface contamination on the TRANSFER CASK and/or accessible portions of the MPC is less than the limits in the LCO. The Surveillance is performed using smear surveys to detect removable surface contamination. The Frequency requires performing the verification during LOADING OPERATIONS in order to confirm that the TRANSFER CASK or OVERPACK can be moved to the ISFSI without spreading loose contamination.

REFERENCES

1. FSAR Sections 8.1.5 and 8.1.6.
2. NRC IE Circular 81-07.

Deleted
B 3.2.3

B 3.2

B 3.2.3 Deleted

HOLTEC INTERNATIONAL COPYRIGHTED MATERIAL

HI-STORM FSAR
REPORT HI-2002444

B 3.2.3-1

Rev. 3

B 3.3 SFSC Criticality Control

B 3.3.1 Boron Concentration

BASES

BACKGROUND A TRANSFER CASK with an empty MPC is placed in the spent fuel pool and loaded with fuel assemblies meeting the requirements of the Certificate of Compliance. A lid is then placed on the MPC. The TRANSFER CASK and MPC are raised to the top of the spent fuel pool surface. The TRANSFER CASK and MPC are then moved into the cask preparation area where the MPC lid is welded to the MPC shell and the welds are inspected and tested. The water is drained from the MPC cavity and drying is performed. The MPC cavity is backfilled with helium. Then, the MPC vent and drain cover plates and closure ring are installed and welded. Inspections are performed on the welds. The TRANSFER CASK bottom pool lid is replaced with the transfer lid to allow eventual transfer of the MPC into the OVERPACK.

For those MPCs containing PWR fuel assemblies of relatively high initial enrichment, credit is taken in the criticality analyses for boron in the water within the MPC. To preserve the analysis basis, users must verify that the boron concentration of the water in the MPC meets specified limits when there is fuel and water in the MPC. This may occur during LOADING OPERATIONS and UNLOADING OPERATIONS.

APPLICABLE SAFETY ANALYSIS The spent nuclear fuel stored in the SFSC is required to remain subcritical ($k_{\text{eff}} < 0.95$) under all conditions of storage. The HI-STORM 100 SFSC is analyzed to store a wide variety of spent nuclear fuel assembly types with differing initial enrichments. For all PWR fuel loaded in the MPC-32 and MPC-32F, and for relatively high enrichment PWR fuel loaded in the MPC-24, -24E, and -24EF, credit was taken in the criticality analyses for neutron poison in the form of soluble boron in the water within the MPC. Compliance with this LCO preserves the assumptions made in the criticality analyses regarding credit for soluble boron.

(continued)

HOLTEC INTERNATIONAL COPYRIGHTED MATERIAL

BASES (continued)

LCO

Compliance with this LCO ensures that the stored fuel will remain subcritical with a $k_{\text{eff}} \leq 0.95$ while water is in the MPC. LCOs 3.3.1.a and 3.3.1.b provide the minimum concentration of soluble boron required in the MPC water for the MPC-24, and MPC-24E/24EF, respectively, for MPCs containing all INTACT FUEL ASSEMBLIES. The limits are applicable to the respective MPCs if one or more fuel assemblies to be loaded in the MPC had an initial enrichment of U-235 greater than the value in Table 2.1-2 of Appendix B to the CoC for loading with no soluble boron credit.

LCO 3.3.1.e provides the minimum concentration of soluble boron required in the MPC water for the MPC-24E and MPC-24EF containing at least one DAMAGED FUEL ASSEMBLY or one fuel assembly classified as FUEL DEBRIS.

LCO 3.3.1.f provides the minimum concentration of soluble boron required in the MPC water for the MPC-32 and MPC-32F based on the fuel assembly array/class and the classification of the fuel as a DAMAGED FUEL ASSEMBLY or FUEL DEBRIS.

All fuel assemblies loaded into the MPC-24, MPC-24E, MPC-24EF, MPC-32, and MPC-32F are limited by analysis to maximum enrichments of 5.0 wt.% U-235.

The LCO also requires that the minimum soluble boron concentration for the most limiting fuel assembly array/class and classification to be stored in the same MPC be used. This means that the highest minimum soluble boron concentration limit for all fuel assemblies in the MPC applies in cases where fuel assembly array/classes and fuel classifications (intact vs. damaged) are mixed in the same MPC. This ensures the assumptions pertaining to soluble boron used in the criticality analyses are preserved.

(continued)

HOLTEC INTERNATIONAL COPYRIGHTED MATERIAL

BASES

APPLICABILITY The boron concentration LCO is applicable whenever an MPC-24, -24E, -24EF, -32, or -32F has at least one PWR fuel assembly in a storage location and water in the MPC. For the MPC-24 and MPC-24E/24EF, when all fuel assemblies to be loaded have initial enrichments less than the limit for no soluble boron credit as provided in CoC Appendix B, Table 2.1-2, the boron concentration requirement is implicitly understood to be zero.

During **LOADING OPERATIONS**, the LCO is applicable immediately upon the loading of the first fuel assembly in the MPC. It remains applicable until the MPC is drained of water

During **UNLOADING OPERATIONS**, the LCO is applicable when the MPC is re-flooded with water after helium cooldown operations. Note that compliance with SR 3.0.4 assures that the water to be used to flood the MPC is of the correct boron concentration to ensure the LCO is upon entering the Applicability.

ACTIONS A note has been added to the **ACTIONS** which states that, for this LCO, separate Condition entry is allowed for each MPC. This is acceptable since the Required Actions for each Condition provide appropriate compensatory measures for each MPC not meeting the LCO. Subsequent MPCs that do not meet the LCO are governed by subsequent Condition entry and application of associated Required Actions.

A.1 and A.2

Continuation of **LOADING OPERATIONS**, **UNLOADING OPERATIONS** or positive reactivity additions (including actions to reduce boron concentration) is contingent upon maintaining the SFSC in compliance with the LCO. If the boron concentration of water in the MPC is less than its limit, all activities **LOADING OPERATIONS**, **UNLOADING OPERATIONS** or positive reactivity additions must be suspended immediately.

(continued)

BASES

ACTIONS
(continued)A.3

In addition to immediately suspending LOADING OPERATIONS, UNLOADING OPERATIONS and positive reactivity additions, action to restore the concentration to within the limit specified in the LCO must be initiated immediately.

One means of complying with this action is to initiate boration of the affected MPC. In determining the required combination of boration flow rate and concentration, there is no unique design basis event that must be satisfied; only that boration be initiated without delay. In order to raise the boron concentration as quickly as possible, the operator should begin boration with the best source available for existing plant conditions.

Once boration is initiated, it must be continued until the boron concentration is restored. The restoration time depends on the amount of boron that must be injected to reach the required concentration.

SURVEILLANCE
REQUIREMENTS
(continued)SR 3.3.1.1

The boron concentration in the MPC water must be verified to be within the applicable limit within four hours prior to entering the Applicability of the LCO. For LOADING OPERATIONS, this means within four hours of loading the first fuel assembly into the cask.

For UNLOADING OPERATIONS, this means verifying the source of borated water to be used to re-flood the MPC within four hours of commencing re-flooding operations. This ensures that when the LCO is applicable (upon introducing water into the MPC), the LCO will be met.

(continued)

HOLTEC INTERNATIONAL COPYRIGHTED MATERIAL

BASES

**SURVEILLANCE
REQUIREMENTS**
(continued)

Surveillance Requirement 3.3.1.1 is modified by a note which states that SR 3.3.1.1 is only required to be performed if the MPC is submerged in water or if water is to be added to, or recirculated through the MPC. This reflects the underlying premise of this SR which is to ensure, once the correct boron concentration is established, it need only be verified thereafter if the MPC is in a state where the concentration could be changed.

There is no need to re-verify the boron concentration of the water in the MPC after it is removed from the spent fuel pool unless water is to be added to, or recirculated through the MPC, because these are the only credible activities that could potentially change the boron concentration during this time. This note also prevents the interference of unnecessary sampling activities while lid closure welding and other MPC storage preparation activities are taking place in an elevated radiation area atop the MPC. Plant procedures should ensure that any water to be added to, or recirculated through the MPC is at a boron concentration greater than or equal to the minimum boron concentration specified in the LCO

REFERENCES 1. FSAR Chapter 6.

HI-STORM 100 SYSTEM FSAR

APPENDIX 12.B

THIS APPENDIX HAS BEEN DELETED

HOLTEC INTERNATIONAL COPYRIGHTED MATERIAL

HI-STORM FSAR
REPORT HI-2002444

HI-STORM 100 FSAR; NON-PROPRIETARY
REVISION 12
MARCH 12, 2014

12.B-1

Rev.4

SUPPLEMENT 12.I

OPERATING CONTROLS AND LIMITS FOR THE HI-STORM 100U SYSTEM

12.I.0 INTRODUCTION

Operation of the HI-STORM 100 System with the underground HI-STORM 100U overpack is identical to operation of the HI-STORM 100 System with the aboveground overpacks up to the point where MPC transfer from the HI-TRAC transfer cask takes place. The loaded MPC is stored in the vertical orientation in the HI-STORM 100U for long-term storage operations. Operating controls and limits described in FSAR Chapter 12 are implemented for the HI-STORM 100U to the extent they are applicable. This supplement describes the unique operating controls and limits, including training requirements and technical specifications, required for the HI-STORM 100U.

12.I.1 OPERATING CONTROLS AND LIMITS

Like the aboveground overpacks, the HI-STORM 100U overpack is completely passive in performing its design functions. It provides for long-term interim storage of the spent fuel without any modifications to the MPC or HI-TRAC transfer cask designs used with the aboveground overpacks. The operating controls and limits established for the MPC and HI-TRAC transfer cask are not altered for use with the HI-STORM 100U.

Operating controls and limits pertaining to movement of the overpack do not apply to the HI-STORM 100U because it is an integral component of the ISFSI and is not able to be moved once installed. It is not required to establish a lift height limit or to evaluate a drop event because the HI-STORM 100U cannot be lifted. It is not required to measure dose rates on the side of the HI-STORM 100U because it is located underground and is, therefore, inaccessible by plant personnel and because side dose rates are limited by shielding from the surrounding soil and provide a negligible contribution to the dose rate at the controlled area boundary.

12.I.2 TRAINING MODULES

The classroom and dry run training programs described in FSAR Subsections 12.2.1 and 12.2.2 must be modified to address the differences between the use of an aboveground, moveable overpack and the belowground, immovable HI-STORM 100U. Specifically, procedures and dry runs must be created or modified to address the operational differences in using the HI-TRAC transfer cask and mating device with the HI-STORM 100U versus the aboveground overpack. These procedures and dry run training shall be based upon the operations of the HI-STORM 100U described in Supplement 8.I.

12.1.3 TECHNICAL SPECIFICATIONS

LCO 3.1.2, which requires periodic surveillance to ensure operability of the cask heat removal system, can be implemented with HI-STORM 100U more easily than for the aboveground overpacks because the outlet air ducts are located at approximately ground level. New LCO 3.1.5, for periodic confirmation of operation of the Impressed Current Cathodic Protection System, is added.

SUPPLEMENT 12.III

OPERATING CONTROLS AND LIMITS FOR THE MPC-68M

The main body of this chapter remains fully applicable for the HI-STORM 100 System using an MPC-68M with the exception that a supplemental cooling system is not required during loading/unloading operations of the MPC-68M in a HI-TRAC transfer cask.

HOLTEC INTERNATIONAL COPYRIGHTED MATERIAL

HI-STORM FSAR

REPORT HI-2002444

HI-STORM 100 FSAR, NON-PROPRIETARY

REVISION 12

MARCH 12, 2014

12.III-1

Rev. 11

CHAPTER 13[†]: QUALITY ASSURANCE

13.0 QUALITY ASSURANCE PROGRAM

13.0.1 Overview

This chapter provides a summary of the quality assurance program implemented for activities related to the design, qualification analyses, material procurement, fabrication, assembly, testing and use of structures, systems, and components of the HI-STORM 100 System and HI-TRAC transfer cask designated as important to safety.

Important-to-safety activities related to construction and deployment of the HI-STORM 100 System are controlled under the NRC-approved Holtec Quality Assurance Program. The Holtec QA program manual (Reference [13.0.2]) is approved by the NRC (Reference [13.0.4]) under Docket 71-0784. The Holtec QA program satisfies the requirements of 10 CFR 72, Subpart G and 10 CFR 71, Subpart H. In accordance with 10 CFR 72.140(d), this approved 10 CFR 71 QA program will be applied to spent fuel storage cask activities under 10 CFR 72. The additional recordkeeping requirements of 10 CFR 72.174 are addressed in the Holtec QA program manual and must also be complied with.

The Holtec QA program is implemented through a hierarchy of procedures and documentation, listed below.

1. Holtec Quality Assurance Program Manual
2. Holtec Quality Assurance Procedures
3. a. Holtec Standard Procedures
b. Holtec Project Procedures

Quality activities performed by others on behalf of Holtec are governed by the supplier's quality assurance program or Holtec's QA program extended to the supplier. The type and extent of Holtec QA control and oversight is specified in the procurement documents for the specific item or service being procured. The fundamental goal of the supplier oversight portion of Holtec's QA program is to provide assurance that activities performed in support of the supply of safety-significant items and services are performed correctly and in compliance with the procurement documents.

[†] This chapter has been prepared in the format and section organization set forth in Regulatory Guide 3.61. However, the material content of this chapter also fulfills the intent of NUREG-1536. Pagination and numbering of sections, figures, and tables are consistent with the convention set down in Chapter 1, Section 1.0, herein. Finally, all terms-of-art used in this chapter are consistent with the terminology of the glossary (Table 1.0.1) and component nomenclature of the Bill-of-Materials (Section 1.5).

HOLTEC INTERNATIONAL COPYRIGHTED MATERIAL

HI-STORM FSAR
REPORT HI-2002444

13.0-1

Rev. 4

HI-STORM 100 FSAR, NON-PROPRIETARY
REVISION 12
MARCH 12, 2014

13.0.2 Graded Approach to Quality Assurance

For the HI-STORM 100 System, a graded approach to quality assurance is used by Holtec. This graded approach is controlled by Holtec Quality Assurance (QA) program documents as described in Section 13.0.1.

NUREG/CR-6407 [13.0.1] provides descriptions of quality categories A, B and C. Using the guidance in NUREG/CR-6407, Holtec International assigns a quality category to each individual, important-to-safety component of the HI-STORM 100 System and HI-TRAC transfer cask. The categories assigned to the cask components are identified in Table 2.2.6. Quality categories for ancillary equipment are provided in Table 8.1.6 on a generic basis. Quality categories for other equipment needed to deploy the HI-STORM 100 System at a licensee's ISFSI are defined on a case-specific basis considering the component's design function.

Activities affecting quality are defined by the purchaser's procurement contract for use of the HI-STORM 100 System at an independent spent fuel storage installation (ISFSI) under the general license provisions of 10CFR72, Subpart K. They may include any or all of the following: design, procurement, fabrication, handling, shipping, storing, cleaning, assembly, inspection, testing, operation, maintenance, repair and monitoring of HI-STORM 100 structures, systems, and components that are important to safety.

The quality assurance program described in the QA Program Manual fully complies with the requirements of 10CFR72 Subpart G and the intent of NUREG-1536 [13.0.3]. However, NUREG-1536 does not explicitly address incorporation of a QA program manual by reference. Therefore, invoking the NRC-approved QA program in this FSAR constitutes a literal deviation from NUREG-1536 and has accordingly been added to the list of deviations in Table 1.0.3. This deviation is acceptable since important-to-safety activities are implemented in accordance with the latest revision of the Holtec QA program manual and implementing procedures. Further, incorporating the QA Program Manual by reference in this FSAR avoids duplication of information between the implementing documents and the FSAR and any discrepancies that may arise from simultaneous maintenance to the two program descriptions governing the same activities.

13.1 through 13.5 INTENTIONALLY DELETED

HOLTEC INTERNATIONAL COPYRIGHTED MATERIAL

HI-STORM FSAR
REPORT HI-2002444

13.0-2

Rev. 4

HI-STORM 100 FSAR, NON-PROPRIETARY
REVISION 12
MARCH 12, 2014

13.6 REFERENCES

- [13.0.1] NUREG/CR-6407, "Classification of Transportation Packaging and Dry Spent Fuel Storage System Components According to Importance to Safety," February 1996.
- [13.0.2] Holtec International Quality Assurance Program, Latest Approved Revision.
- [13.0.3] NUREG-1536, "Standard Review Plan for Dry Cask Storage Systems," January 1997.
- [13.0.4] NRC QA Program Approval for Radioactive Material Packages No. 0784, Docket 71-0784.

HOLTEC INTERNATIONAL COPYRIGHTED MATERIAL

HI-STORM FSAR
REPORT HI-2002444

13.6-1

Rev. 4

SUPPLEMENT 13.I

QUALITY ASSURANCE PROGRAM FOR THE HI-STORM 100U SYSTEM

The quality assurance program described in Chapter 13 is implemented for activities related to the design, qualification analyses, material procurement, fabrication, assembly, testing and use of structures, systems, and components of the HI-STORM 100U System designated as important-to-safety.

HOLTEC INTERNATIONAL COPYRIGHTED MATERIAL

HI-STORM FSAR
REPORT HI-2002444

13.I-1

Rev. 9

HI-STORM 100 FSAR, NON-PROPRIETARY
REVISION 12
MARCH 12, 2014

SUPPLEMENT 13.III

QUALITY ASSURANCE FOR THE MPC-68M

The main body of this chapter remains fully applicable for the HI-STORM 100 System using an MPC-68M.

HOLTEC INTERNATIONAL COPYRIGHTED MATERIAL

HI-STORM FSAR
REPORT HI-2002444
HI-STORM 100 FSAR, NON-PROPRIETARY
REVISION 12
MARCH 12, 2014

13.III-1

Rev. 11