



Michael P. Gallagher
Vice President, License Renewal
Exelon Nuclear

200 Exelon Way
Kennett Square, PA 19348

610 765 5958 Office
610 765 5956 Fax
www.exeloncorp.com

michaelp.gallagher@exeloncorp.com

10 CFR 50
10 CFR 51
10 CFR 54

RS-14-002

January 13, 2014

U. S. Nuclear Regulatory Commission
Attention: Document Control Desk
Washington, DC 20555-0001

Braidwood Station, Units 1 and 2
Facility Operating License Nos. NPF-72 and NPF-77
NRC Docket Nos. STN 50-456 and STN 50-457

Byron Station, Units 1 and 2
Facility Operating License Nos. NPF-37 and NPF-66
NRC Docket Nos. STN 50-454 and STN 50-455

Subject: Response to NRC Requests for Additional Information, Set 4, dated December 12, 2013, related to the Braidwood Station, Units 1 and 2, and Byron Station, Units 1 and 2 License Renewal Application

References: 1. Letter from Michael P. Gallagher, Exelon Generation Company LLC (Exelon) to NRC Document Control Desk, dated May 29, 2013, "Application for Renewed Operating Licenses."

2. Letter from John W. Daily, US NRC to Michael P. Gallagher, Exelon, dated December 12, 2013 "Requests for Additional Information for the Review of the Byron Nuclear Station, Units 1 and 2, and Braidwood Nuclear Station, Units 1 and 2, License Renewal Application – Aging Management, Set 4 (TAC NOS. MF1879, MF1880, MF1881, AND MF1882)

In the Reference 1 letter, Exelon Generation Company, LLC (Exelon) submitted the License Renewal Application (LRA) for the Byron Station, Units 1 and 2, and Braidwood Station, Units 1 and 2 (BBS). In the Reference 2 letter, the NRC requested additional information to support the staffs' review of the LRA.

Enclosure A contains the responses to these requests for additional information.

Enclosure B contains updates to sections of the LRA (except for the License Renewal Commitment List) affected by the responses.

January 13, 2014
U.S. Nuclear Regulatory Commission
Page 2

Enclosure C provides an update to the License Renewal Commitment List (LRA Appendix A, Section A.5). There are no other new or revised regulatory commitments contained in this letter.

If you have any questions, please contact Mr. Al Fulvio, Manager, Exelon License Renewal, at 610-765-5936.

I declare under penalty of perjury that the foregoing is true and correct.

Executed on 01-13-2014

Respectfully,



Michael P. Gallagher
Vice President - License Renewal Projects
Exelon Generation Company, LLC

Enclosures: A: Responses to Requests for Additional Information
B: Updates to affected LRA sections
C: License Renewal Commitment List Changes

cc: Regional Administrator – NRC Region III
NRC Project Manager (Safety Review), NRR-DLR
NRC Project Manager (Environmental Review), NRR-DLR
NRC Senior Resident Inspector, Braidwood Station
NRC Senior Resident Inspector, Byron Station
NRC Project Manager, NRR-DORL-Braidwood and Byron Stations
Illinois Emergency Management Agency - Division of Nuclear Safety

Enclosure A

**Byron and Braidwood Stations (BBS), Units 1 and 2
License Renewal Application
Responses to Requests for Additional Information**

RAI B.2.1.22-1
RAI B.2.1.22-2
RAI B.2.1.6-1
RAI B.2.1.6-2
RAI B.2.1.6-3
RAI B.3.1.1-1
RAI B.3.1.1-2
RAI B.2.1.7-1
RAI B.2.1.7-2
RAI B.2.1.7-4
RAI B.2.1.7-5
RAI B.2.1.7-6
RAI B.2.1.5-1
RAI B.2.1.5-2
RAI B.2.1.19-1

RAI B.2.1.22-1, ASME Code Class 1 Socket weld failure (036)

Applicability: Byron Nuclear Station (Byron), Units 1 and 2

Background:

Generic Aging Lessons Learned (GALL) Report aging management program (AMP) XI.M35 states under the “detection of aging effects” program element that the one-time inspection program does not apply to plants that have experienced cracking in ASME Code Class 1 small-bore piping due to stress corrosion, cyclical (including thermal, mechanical, and vibration fatigue) loading, or thermal stratification and thermal turbulence. License renewal application (LRA) Section B.2.1.22 states that Byron and Braidwood Nuclear Station (Braidwood) have not experienced this type of cracking.

Issue:

The applicant documented plant-specific operating experience in the LRA section which states that, in 1998, Byron, Unit 1, experienced a failure of an ASME Code Class 1 socket weld that attached an elbow to a pipe on a safety injection system line. The applicant attributed the failure to a fabrication flaw.

Based on the limited information provided at the audit, the staff determined that the failure could have been caused by vibration fatigue.

Request :

Provide information in terms of metallurgical analysis to support the conclusion that the failure was caused by a fabrication flaw.

If failure of ASME Code Class 1 small-bore piping is identified due to vibration fatigue, provide a plant-specific program that includes periodic inspections, otherwise explain why the one-time inspection program will adequately manage cracking.

Exelon Response:

On February 19, 1998, during Byron Unit 1 startup activities from a refueling outage, a leak was detected on the upstream weld to a 1½ inch socket welded elbow on the “D” Safety Injection (SI) cold leg injection line. The elbow, pipe, and weld were analyzed by Commonwealth Metallurgy Group personnel and the results were documented in a metallurgical evaluation report which is summarized below.

The metallurgical evaluation concluded that the leak originated from a through wall crack that initiated at a large lack of fusion defect at the root of the socket weld, a fabrication flaw. The weld was identified as an original installed shop weld and was located on a portion of the Safety Injection system which was designed and fabricated in accordance with ASME Section III, 1971 edition with addenda through summer 1973. The failure occurred at a class 1 socket weld attaching a vertical 1½ inch stainless steel pipe to a 90° stainless socket weld elbow. The weld material was 300 series stainless steel. The through wall crack was located entirely in the weld and measured 3/16 inches long (circumferentially) at the exterior surface of the weld. The weld leg lengths, material, and contour met ASME Section III requirements. Microscopic examination

revealed that the crack initiated at the root of the weld at a large lack of fusion region which was measured to be up to 0.1" long. Microscopic examination also revealed that a portion of the crack exhibited a dark stain which suggested that this portion of the crack may have been present for a long time prior to the failure.

The "D" SI cold leg injection line is only placed in service during surveillances and when it is called upon to perform its intended function during accident conditions. Over time, when this line was placed in service and experienced nominal vibration levels, the edge of the weld material next to the lack of fusion defect experienced large localized stress concentrations which created a crack tip. Once the crack tip had formed, and as the line experienced nominal vibration when it was placed in service, the large localized stress concentrations propagated the crack through the remaining weld until the crack became through wall. The lack of fusion defect at the weld root was most likely due to poor workmanship during the fabrication and welding process and is therefore, not considered age-related degradation.

An extent of condition review was performed in 1998 and eighteen (18) additional socket welds fabricated at the same time were examined by PT examination methods. These inspections were distributed among the four (4) Byron Unit 1 redundant SI cold leg injection lines. The examinations revealed no additional through wall cracks. Since this event in 1998, no additional cracks have been observed on the four redundant Unit 1 SI cold leg injection lines. Further, since commercial operation commenced in 1986, no cracks have been observed on the four Unit 2 SI cold leg injection lines.

The failure mechanism, a lack of fusion defect at the weld root causing a through wall crack at nominal vibration levels, is consistent with mechanisms described in EPRI TR-107455, "Vibration Fatigue of Small Bore Socket-Welded Pipe Joints" and EPRI Technical Update 1003542, "Socket Weld Resolution Guideline". These reports conclude that the presence of a weld root defect can significantly increase the susceptibility of a socket weld to develop crack tips at nominal vibration levels, which can then propagate to through wall cracks. For example, EPRI TR107455 concludes that the presence of a weld root defect up to 0.060 inches can reduce the fatigue strength of the socket weld by a factor of two (2). Since the actual size of the lack of fusion region in the 1½ inch weld that leaked in 1988 was measured to be up to 0.1 inches, the reduction in fatigue strength of the socket weld was most likely greater than a factor of 2. The EPRI reports also conclude that socket welds that are properly designed and fabricated (e.g., without root defects) and operate at nominal vibration levels are not expected to develop crack tips, which can then propagate.

The creation of a crack under excessive vibration levels is not considered a likely root cause since the UFSAR documents that the Byron Units 1 and 2 SI cold leg injection lines, including the Unit 1 "D" loop were monitored for vibration during preoperational testing, prior to commercial operation. All monitored lines with excessive vibration levels were identified and corrected prior to commercial operation. The UFSAR documents that the criterion for excessive vibration levels was based on alternating stress amplitudes greater or equal to 12 ksi. In addition, the EPRI reports document that failures due to excessive vibration levels tend to occur at the weld toe and not the weld root. The metallurgical evaluation documents that the crack initiated at the root of the weld, propagated entirely within the weld, and did not propagate through the toe of the weld.

The following factors support the conclusion that the 1998 Byron Unit 1 "D" SI cold leg injection line socket weld through wall crack was due to a fabrication flaw and was not due solely to

cyclical vibration fatigue, and additional future socket weld cracks due solely to vibration are not expected to occur on the Byron Units 1 and 2 SI cold leg injection lines during the period of extended operation.

- 1) The Byron Units 1 and 2 SI cold leg injection lines were designed and fabricated in accordance to ASME Section III. Socket welds that are properly designed and fabricated are not expected to develop crack tips at nominal vibration levels.
- 2) Pre-operational monitoring of the SI cold leg injections lines confirmed nominal vibration levels.
- 3) Since commercial operation began all Byron Units 1 and 2, the SI cold leg injections lines have operated without any through wall cracks; except for the Byron Unit 1 1998 weld failure which was attributed to a lack of fusion defect at the root of the weld.
- 4) An extent of condition review was performed in 1998 and eighteen (18) additional socket welds fabricated at the same time and distributed among the four (4) Byron Unit 1 redundant SI cold leg injection lines were examined by PT examination methods. No crack indications were reported in these examinations.
- 5) Operating experience, as documented by EPRI, indicates that socket welds with large lack of fusion defects at the weld root can fail at nominal vibration levels.
- 6) The metallurgical evaluation of the failed 1998 Byron Unit 1 "D" SI cold leg injection line socket weld concluded that the root cause of the through wall crack was due to a lack of fusion defect at the root of the weld.

Therefore, there is confidence that the Byron Units 1 and 2 SI cold leg injection lines will not experience additional cracks solely due to cyclical vibration fatigue during the period of extended operation and a plant-specific program that includes periodic inspections of the SI cold leg injection lines is not required.

To confirm the above conclusion, the weld that replaced the failed weld in 1998 will be included in the Byron Unit 1 socket weld inspection sample population for the One-Time Inspection of ASME Code Class 1 Small-Bore Piping aging management program.

The One-Time Inspection of ASME Code Class 1 Small-Bore Piping aging management program inspections of small-bore piping welds will provide reasonable assurance to demonstrate that the cracking aging effect will be adequately managed during the period of extended operation.

The Byron and Braidwood LRA Appendix A, Section A.2.1.22, and Appendix B, Section B.2.1.22, are revised to make it clear that the Byron Unit 1 weld replaced in 1998 will be included in the program inspection scope, as shown in Enclosure B of this letter. The Byron and Braidwood LRA Table A.5 Commitment List, Item 22, is also updated to include this provision as shown in Enclosure C of this letter.

RAI B.2.1.22-2, Small-bore piping weld sample populations (036)

Applicability: Byron and Braidwood Nuclear Station (Braidwood), all units

Background:

The LRA states that AMP B.2.1.22, “One-Time Inspection of ASME Code Class 1 Small-Bore Piping” is an existing program that is consistent with the program elements in GALL Report AMP XI.M35, “One-Time Inspection of ASME Code Class 1 Small-Bore Piping.”

GALL Report AMP XI.M35 states under the “detection of aging effects” program element that “(t)his inspection should be performed at a sufficient number of locations to ensure an adequate sample. This number, or sample size, is based on susceptibility, inspectability, dose considerations, operating experience, and limiting locations of the total population of ASME Code Class 1 small-bore piping locations.”

Issue:

The LRA section does not provide the weld populations. It is not clear to the staff how the inspection sample(s) would be selected.

Request :

Provide the population of in-scope small-bore piping welds for each weld type (i.e., butt welds and socket welds) at each unit.

Exelon Response:

The tables below provide the total approximate population of ASME Section III Class 1 in-scope small-bore piping welds equal to or greater than 1 NPS and less than 4 NPS for butt welds and socket welds at each Byron and Braidwood unit. These tables were developed by reviewing ISI program documents and drawings for small bore piping.

	Braidwood Unit 1	Braidwood Unit 2
ASME Section III Class 1 Small-Bore Piping Butt Welds	136	129
ASME Section III Class 1 Small-Bore Piping Socket Welds	933	962

	Byron Unit 1	Byron Unit 2
ASME Section III Class 1 Small-Bore Piping Butt Welds	175	181
ASME Section III Class 1 Small-Bore Piping Socket Welds	872	828

During the development of the License Renewal Application, the population of ASME Section III Class 1 socket and butt welds equal to one (1) inch was not known and very conservative estimates were used for the program as described in LRA Appendix A.2.1.22 and B.2.1.22. As a result of the efforts required to respond to this RAI, more refined populations have been established, especially for the butt weld population, and changes to the LRA are appropriate.

The inspection sample size will include 10% of the socket weld population up to a maximum of 25 socket welds for each Byron and Braidwood unit and 10% of the butt weld population up to a maximum of 25 butt welds for each Byron and Braidwood unit. These inspection sample sizes will provide reasonable assurance that the cracking aging effect will be managed during the period of extended operation.

The Byron and Braidwood LRA Appendix A, Section A.2.1.22, and Appendix B, Section B.2.1.22, are revised to reflect these changes as shown in Enclosure B of this letter.

RAI B.2.1.6-1, Control rod assembly CASS components (014)

Applicability: Byron and Braidwood Stations

Background:

LRA Section B.2.1.6 describes the applicant's Thermal Aging Embrittlement of Cast Austenitic Stainless Steel (CASS) Program. LRA Section B.2.1.6 states that this program is a new condition monitoring program that provides assurance that reactor coolant pressure boundary CASS components (i.e., Class 1 piping and control rod assembly pressure boundary components) susceptible to thermal aging embrittlement meet the specified intended functions.

The aging management review results in LRA Table 3.1.2-2 identify both CASS and non-cast stainless steel as the materials used to fabricate the control rod assembly components, which include latch housing, rod travel housing, cap, and control rod drive mechanism adapter. However, the LRA does not provide any more specific information on the materials used to fabricate these different components of the control rod assembly (pressure boundary).

By contrast, Section 15.4.8.1.1, "Design Precautions and Protection" of the applicant's updated final safety analysis report (UFSAR) states that the latch mechanism housing and rod travel housing are each a single length of forged Type 304 stainless steel.

Issue:

Given the lack of specific information on the materials of fabrication for the different control rod assembly pressure boundary components, the staff needs to clarify which components of the control rod assembly are made of CASS, so that CASS components are appropriately identified in the scope of the applicant's program.

Request:

Clarify which components of the control rod assembly are made of CASS so that CASS components are appropriately identified in the scope of the applicant's program.

Exelon Response:

At Bryon and Braidwood Stations, Units 1 and 2, a control rod assembly is defined as a control rod drive mechanism (CRDM) and CRDM adapter. The only control rod assembly components made of cast austenitic stainless steel (CASS) are latch housings. These components were appropriately identified in the scope of the LRA Section B.2.1.6 Thermal Aging Embrittlement of Cast Austenitic Stainless Steel (CASS) aging management program.

A CRDM is comprised of three (3) pressure-retaining components: the latch housing, rod travel housing, and cap. The material used to fabricate the CRDM pressure-retaining components are as follows: latch housings are fabricated from both forged 304 stainless steel and centrifugally-cast, low-molybdenum austenitic stainless steel, the rod travel housings are fabricated from forged 304 stainless steel, and the caps are fabricated from forged 304 stainless steel.

The pressure-retaining CRDM adapters are fabricated from forged 304 stainless steel.

It was determined that some of the information in UFSAR Section 15.4.8.1.1 and Table 5.2-2 for the CRDM components is incorrect. The issue of incorrect information in the UFSAR has been entered into the corrective action program. No LRA changes are required as a result of this response.

RAI B.2.1.6-2, Susceptible CASS components with ferrite content greater than 25 percent (014)

Applicability: Byron and Braidwood Stations

Background:

LRA Section B.2.1.6 states that the applicant's Thermal Aging Embrittlement of Cast Austenitic Stainless Steel (CASS) Program is consistent with GALL Report AMP XI.M12, "Thermal Aging Embrittlement of Cast Austenitic Stainless Steel Program (CASS)." GALL Report AMP XI.M12 states that a flaw tolerance evaluation for components with a ferrite content up to 25 percent is performed according to the principles associated with ASME Code, Section XI, IWB-3640 for submerged arc welds. The GALL Report also states that a flaw tolerance evaluation for piping with greater than 25 percent ferrite is performed on a case-by-case basis by using the applicant's fracture toughness data.

Issue:

The LRA does not address whether the applicant has any susceptible CASS components with a ferrite content greater than 25 percent. In addition, the LRA does not clearly address whether the flaw tolerance evaluation for susceptible CASS components with greater than 25 percent ferrite will be performed on a case-by-case basis in the applicant's program. The staff also needs additional information regarding high-ferrite CASS components and flaw tolerance evaluation for the components.

Request:

1. Clarify whether the applicant has any susceptible CASS components with a ferrite content greater than 25 percent.
2. If susceptible CASS components with a ferrite content greater than 25 percent are present, provide the following information for the CASS components: (1) component name, (2) casting method and material grade (e.g., centrifugally cast CF8), (3) ferrite contents based on a method consistent with GALL Report AMP XI.M12 and, if existent, actual measurements, (4) clarification as to whether applicant's flaw tolerance evaluation will be performed on a case-by-case basis using relevant fracture toughness data, and (5) applicant's methodology to be used in the flaw tolerance evaluation and the technical basis for the methodology.

Exelon Response:

1. There are no susceptible cast austenitic stainless steel (CASS) ASME Class 1 pressure boundary components at Byron and Braidwood Stations, Units 1 and 2, with a calculated δ -ferrite of greater than 25 percent using the Hull's equivalent factors.

The ASME Class 1 pressure boundary components fabricated from CASS consist of the reactor coolant pipe fittings (elbows) and 35 of the 53 control rod drive mechanism (CRDM) latch housings. Low-molybdenum CASS was used for both the reactor coolant pipe fittings and the CRDM latch housings. A screening evaluation using casting method and calculated δ -ferrite was performed for the pipe fittings. The reactor coolant pipe fittings are static cast, therefore, the δ -ferrite was calculated using the Hull's equivalent factors, as specified in

NUREG/CR-4513 "Estimation of Fracture Toughness of Cast Stainless Steels During Thermal Aging in LWR Systems." The calculated δ -ferrite was determined to be less than 25 percent for all reactor coolant pipe fittings. The CRDM latch housings were centrifugally-cast, and determined not susceptible based on low-molybdenum and casting method.

2. There are no susceptible cast austenitic stainless steel ASME Class 1 pressure boundary components installed at Byron and Braidwood Stations, Units 1 and 2, with a calculated δ -ferrite of greater than 25 percent.

RAI B.2.1.6-3, Operating Experience for control rod assembly and reactor coolant fitting components made of CASS (014)

Applicability: Byron and Braidwood Stations

Background:

LRA Section B.2.1.6 describes the applicant's Thermal Aging Embrittlement of Cast Austenitic Stainless Steel (CASS) Program. LRA Section B.2.1.6 states that this program manages loss of fracture toughness due to thermal aging embrittlement of reactor coolant pressure boundary CASS components (i.e., Class 1 piping and control rod assembly components).

Issue:

LRA Section B.2.1.6 includes a section to discuss operating experience related to the applicant's program. However, the staff noted that this operating experience discussion does not provide operating experience that is specific to the control rod assembly components and reactor coolant fittings made of CASS. The staff needs this information in order to ensure that any previous operating experience related to these CASS components does not identify a need to enhance the applicant's program.

Request:

Provide operating experience specific to the CASS control rod assembly components and reactor coolant fittings, including relevant inspection results.

Exelon Response:

The Thermal Aging Embrittlement of Cast Austenitic Stainless Steel (CASS) is a new condition-monitoring program. The components in the Thermal Aging Embrittlement of Cast Austenitic Stainless Steel program are ASME Class 1 components and are currently monitored and managed by the ASME Section XI Inservice Inspection Program.

Periodic ASME Section XI inspections and examinations have been performed on the ASME Class 1 components, including the reactor coolant CASS fittings and the CASS control rod housing assemblies, during the past three (3) 10-year inspection intervals. These previous examinations included visual examinations during pressure testing (VT-2) of the reactor coolant pressure boundary and ultrasonic examination (UT) of welds of CASS pipe fittings to forged pipes or nozzle safe-ends. The Byron and Braidwood Station, Units 1 and 2 previous ASME Section XI ISI examinations of the reactor coolant pressure boundary fittings and control rod housing assemblies did not identify any conditions that exceeded the applicable acceptance standards of any Class 1 CASS components included in the Thermal Aging Embrittlement of Cast Austenitic Stainless Steel (CASS) program.

RAI B.3.1.1-1, Monitoring of additional plant design transients for fatigue (055)

Applicability: Byron and Braidwood Stations

Background:

The Fatigue Monitoring Program is an existing program that has been monitoring and tracking transients since initial plant startup. LRA Section B.3.1.1 identifies an enhancement to the “scope of program,” “preventive actions,” “parameters monitored or inspected,” and “acceptance criteria” program elements of the Fatigue Monitoring Program. Specifically, it states that the program will “[m]onitor and track additional plant transients that are significant contributors to component fatigue usage.”

GALL Report X.M1, “Fatigue Monitoring,” states that the program should monitor all plant design transients that contribute significantly to the fatigue usage factor.

Issue:

For the additional plant transients that will be monitored and tracked as a result of this enhancement, it is unclear to the staff how the applicant ensures that the accumulated transients from initial plant startup will be appropriately accounted for, both in number of cycles and severity, prior to the program/procedure enhancement.

Request:

1. Describe the methodology that will be used to identify the additional plant transients that contribute significantly to the fatigue usage factor and justify that it will ensure the program monitors all plant design transients that contribute significantly to the fatigue usage factor.
2. For the additional transients that will be monitored and tracked, explain how the existing program ensures that cycles from initial plant startup will be appropriately captured, both cycle counts and severity, by the Fatigue Monitoring Program upon entering the period of extended operation.
3. Justify that this baseline cycle count will appropriately account for each of the additional transients such that fatigue will be managed during the period of extended operation.

Exelon Response:

1. All additional plant transients that contribute significantly to the fatigue usage factor have been identified and are included in the list of transients in Tables 4.3.1-1 through 4.3.1-6. The current analyses of record were used to determine which design transients were applicable to the specific TLAA's being documented for license renewal.

The methodology used to identify the additional plant transients that contribute significantly to the fatigue usage factor involved a comprehensive review of design specifications and design fatigue analyses. A tabulation of the fatigue analyses design transients for all of the systems and components within license renewal scope was completed. The transients come from both the original individual equipment or design specifications and from the subsequent licensing basis evaluations using transients discovered during operation of the

plant that were not considered in the original analyses. Examples of subsequent licensing basis evaluations are the pressurizer surge line and lower head transients, and the feedwater stratification transients.

A comparison of the results of the review of the current licensing basis transients against the transients currently monitored by the Fatigue Monitoring program was completed. This comparison determined the additional transients to be monitored by the Fatigue Monitoring program for the period of extended operation. The list of the additional transients to be added to the Fatigue Monitoring program, the LRA tables which contain the transients, and the source of the transient is in the following table.

Additional Transients:

Transient	LRA Table	Transient Number	Source
Pressurizer Spray Transients associated with Plant Heatups and Cooledowns	4.3.1-1 and 4.3.1-4	Input from 1 and 2	Pressurizer Spray Nozzle EAF Analysis and defined in the analysis
Bypass Line Tempering Valve Failure	4.3.1-1 and 4.3.1-4	31	Based on review of Analysis of Record
Excessive Bypass Feedwater Flow	4.3.1-1 and 4.3.1-4	32	Based on review of Analysis of Record
Reactor Pressure Vessel Stud Tensioning and Detensioning	4.3.1-1 and 4.3.1-4	36	Based on review of Analysis of Record
RCP Piping - Loss of Seal Injection Flow	4.3.1-2 and 4.3.1-5	16	Based on review of Analysis of Record
RCP Piping - Loss of Component Cooling Water Flow	4.3.1-2 and 4.3.1-5	18	Based on review of Analysis of Record

As indicated in the table, the Pressurizer Spray transients associated with Plant Heatups and Cooledowns were defined in the Environmentally Assisted Fatigue (EAF) analysis for the Pressurizer Spray Nozzle. The analysis baselined and computed 60-year cycle projections in the same manner as was performed for the transients in the LRA. The 60-year cycle projection was used to determine the CUF_{en} for the Pressurizer Spray Nozzle contained in LRA Table 4.3.4-1.

Therefore, since this methodology used all plant design transients that contribute significantly to the determination of the fatigue usage from the analyses of record and from the analyses performed to determine the effects of EAF, the changes to be made to the transient monitoring requirements of the Fatigue Monitoring program will ensure the program monitors all plant design transients which contribute significantly to the determination of the fatigue usage factor.

2. For the additional transients that will be monitored and tracked, cycles from initial plant startup will be appropriately captured, both cycle counts and severity, by the Fatigue Monitoring program prior to entering the period of extended operation by implementation of

Commitment 43, item 2. The transients determined to occur from initial plant startup, considering both cycle counts and severity, through March 31, 2012 are the "Baseline Cycles" contained in the LRA Tables 4.3.1-1 through 4.3.1-6 with Note 1, and the Pressurizer Spray Nozzle EAF Analysis. Since the additional transients are contained in the LRA Tables 4.3.1-1 through 4.3.1-6, the additional transients have already been baselined as of March 31, 2012. Transient cycles from initial plant startup through March 31, 2012 were determined using information retrieved from plant historical records. Additionally, for the period of 1999 through March 31, 2012, analysis of high resolution plant computer data was also used to determine transient cycles. These baseline cycles and any additional cycles incurred will be added to the station surveillance procedures implementing Commitment 43, Item 2, prior to the period of extended operation.

3. All additional transients identified have been baselined. The procedure changes required to implement Commitment 43, Item 2, will incorporate the additional transients to be monitored by the Fatigue Monitoring program and the associated baseline cycles. Therefore, fatigue will be managed during the period of extended operation.

RAI B.3.1.1-2, Analyses other than ASME Code Section III fatigue analyses in the Fatigue Monitoring Program (055)

Applicability: Byron and Braidwood Stations

Background:

LRA Section B.3.1.1 states that the Fatigue Monitoring Program is an existing program that manages cumulative fatigue damage by monitoring and tracking transients. The LRA states that the program will be used to ensure the validity of the ASME Code Section III fatigue analyses.

LRA Section 4.7.4 states a Class 1 fracture mechanics analysis was performed on the Byron and Braidwood, Units 1 and 2, residual heat removal heat exchangers tube side inlet and outlet nozzles. LRA Section 4.7.6 states a flaw growth analysis was performed on the Byron, Unit 2, pressurizer seismic restraint lug. LRA Section 4.7.7 states that a crack growth analysis was performed on the Braidwood, Unit 2, feedwater pipe elbow. LRA Section 4.7.8 describes crack growth rate analyses on primary system components. The LRA states that these analyses were performed consistent with ASME Code Section XI and identifies them as plant-specific time-limited aging analyses (TLAAs). The LRA disposes these TLAAs in accordance with 10 CFR 54.21(c)(1)(iii) and credits the Fatigue Monitoring Program to monitor the transient cycles to ensure the transient inputs in the fracture mechanics or fatigue crack growth analyses supporting the flaw evaluations will not be exceeded during the period of extended operation.

Issue:

LRA Section B.3.1.1 states the Fatigue Monitoring Program will be used to monitor transients for ASME Code Section III fatigue analyses. It is unclear to the staff whether analyses other than ASME Code Section III fatigue analyses are within the scope of the Fatigue Monitoring Program. The flaw evaluations in LRA Sections 4.7.4, 4.7.6, 4.7.7, and 4.7.8 credit the Fatigue Monitoring Program to monitor transient cycles.

Request:

1. Clarify whether analyses other than ASME Code Section III fatigue analyses are within the scope of the Fatigue Monitoring Program. If so, identify all non-ASME Code Section III fatigue analyses that credit the Fatigue Monitoring Program to ensure the transient inputs to the analyses will not be exceeded.
2. For all non-ASME Code Section III fatigue analyses identified in the response above, justify that it is appropriate to credit the Fatigue Monitoring Program to disposition these analyses in accordance with 10 CFR 54.21(c)(1)(iii) such that effects of aging on the intended function(s) of these components will be adequately managed for the period of extended operation.
3. Update the program elements of the Fatigue Monitoring Program in LRA Section B.3.1.1 and UFSAR Section A.3.1.1 as necessary, based on the above requests.

Exelon Response:

1. Analyses other than ASME Code Section III fatigue analyses are within the scope of the Fatigue Monitoring program. As stated in the LRA, the Fatigue Monitoring program is credited for ensuring the transient inputs to the ASME Section III fatigue exemptions as described in LRA Section 4.3.2, the allowable stress analyses associated with ASME Section III and ANSI B31.1 as described in LRA Section 4.3.3, and the flaw evaluation analyses performed in accordance with ASME Section XI, IWB-3600, as described in LRA Sections 4.7.4, 4.7.6, 4.7.7, and 4.7.8.
2. Each of the non-ASME Section III fatigue analyses crediting the Fatigue Monitoring program have as analysis input the transients which are presented in LRA Tables 4.3.1-1 through 4.3.1-6. All of these transients will be monitored by the enhanced Fatigue Monitoring program. Therefore, since the transients will be monitored by the enhanced Fatigue Monitoring program the associated aging effects on the intended function(s) of these components will be adequately managed for the period of extended operation.
3. Based on the responses above, an enhancement has been added to increase the scope of the Fatigue Monitoring program to include analyses other than ASME Section III fatigue analyses. LRA UFSAR Supplement Section A.3.1.1, and the program elements of the Fatigue Monitoring program contained in LRA Section B.3.1.1 are updated in Enclosure B, and the License Renewal Commitment List, LRA Section A.5, is updated in Enclosure C.

RAI B.2.1.7-1, FMECA for A/LA items 2 and 7 in LRA Appendix C (017)

Applicability: Byron and Braidwood Stations

Background:

LRA Appendix C discusses the applicant's responses to applicant/licensee action item (A/LAI) No. 2 and No. 7 of MRP-227-A. In its responses, the applicant identified two components that were fabricated of different materials than those considered in MRP-227-A. Specifically, the applicant indicated that the upper instrumentation conduit and supports: brackets, clamps, terminal blocks and conduit straps at Bryon and Braidwood were fabricated from CASS rather than forged 304 stainless steel. The applicant stated that due to the material difference in these components a failure mode, effects, and criticality analysis (FMECA) was performed.

For the upper instrumentation conduit and supports: brackets, clamps, terminal blocks, and conduit straps, installed at Byron and Braidwood, the FMECA determined that, with the inclusion of loss of fracture toughness due to thermal aging embrittlement as a degradation mechanism, the components remained in the "No Additional Measures" inspection category.

Issue:

The staff noted that the details and basis for the applicant's FMECA conclusion were not provided for the upper instrumentation conduit and supports: brackets, clamps, terminal blocks, and conduit straps. The staff noted that this information is necessary to assess whether the applicant will implement an adequate aging management strategy for these components.

The staff also noted that the applicant's response to A/LAI No. 2 focused on how thermal embrittlement was assessed in the FMECA process, but did not provide a discussion on how irradiation embrittlement was considered. It is not clear to the staff if or how irradiation embrittlement was considered in the applicant's FMECA for the upper instrumentation conduit and supports: brackets, clamps, terminal blocks, and conduit straps, installed at Byron and Braidwood.

Request:

Describe in detail the FMECA performed for these components when considering loss of fracture toughness due to thermal and irradiation embrittlement, and justify the conclusion that components were ranked as Category A components, which equates to the "No Additional Measures" inspection category.

Exelon Response:

A Failure Mode, Effects, and Criticality Analysis (FMECA) was performed compliant with the guidance provided in Section 6 of MRP-191, "Materials Reliability Program: Screening, Categorization, and Ranking of Reactor Internals Components for Westinghouse and Combustion Engineering PWR Design." The use of CASS material for some components of the upper instrumentation conduit and supports: brackets, clamps, terminal blocks, and conduit straps at Byron and Braidwood Stations, Units 1 and 2, was identified after a detailed review of the plant-specific design documentation.

Using the guidance of MRP-191, an expert panel of knowledgeable Westinghouse (original equipment manufacturer) and utility personnel was assembled and charged with evaluating any potential effect of the material variance on the MRP-191 industry generic susceptibility ranking of the specified sample of reactor internals components. Compliant with the MRP-191 guidance, the expert panel evaluated the component function, potential degradation mechanisms, likelihood of failure, and likelihood of damage.

The use of CASS material was specified as an acceptable material in the original design documents and is supportive of fulfilling the design function of the upper instrumentation conduit and supports: brackets, clamps, terminal blocks, and conduit straps. The expert panel, therefore, concluded that there was no impact to the function of the component as a result of the use of CASS material.

Upper instrumentation conduit and supports: brackets, clamps, terminal blocks, and conduit straps made of forged 304 stainless steel were evaluated in MRP-191 for potential degradation mechanisms. In the generic evaluation, no degradation mechanisms reached the screening threshold as documented in MRP-191, Table 6-5. Since CASS material was used rather than forged 304 stainless steel, the expert panel re-evaluated the degradation mechanisms. The operating parameters (temperature and fluence) of the component are unchanged by the use of CASS material. The upper instrumentation conduit and supports: brackets, clamps, terminal blocks, and conduit straps experience little or no load; therefore stress was not considered a factor consistent with the conclusions of the generic effort. The component is located above the active core in a low fluence region and determined to be below the MRP-191 screening threshold for irradiation embrittlement. CASS material may be susceptible to thermal aging embrittlement and therefore for the Byron and Braidwood Stations, Units 1 and 2, upper instrumentation conduit and supports: brackets, clamps, terminal blocks, and conduit straps, screened in for the degradation mechanism of thermal aging embrittlement. All other screening for degradation mechanisms and potential susceptibility remained the same as the evaluation for forged 304 stainless steel material as summarized in MRP-191, since CASS material has the same aging degradation mechanisms as forged stainless steel except for thermal aging embrittlement.”

The likelihood of failure of the upper instrumentation conduit and supports: brackets, clamps, terminal blocks, and conduit straps with the consideration of thermal aging embrittlement was determined to be “Low” by the expert panel. Based on review of the criteria in the NRC letter of May 19, 2000, “License Renewal Issue No. 98-0030, thermal Aging Embrittlement of Cast Austenitic Stainless Steel Components” (NRC ADAMS Accession No. ML003717179), it was confirmed that the Byron and Braidwood Stations, Units 1 and 2, components are potentially susceptible to loss of fracture toughness due to thermal aging embrittlement. However, the components experience little to no load and there have been no known failures of the component in the industry. Consistent with the generic MRP-191, Table 6-2 ranking criteria, this assessment was assigned a “Low” categorization for component failure likelihood.

The likelihood of damage resulting from degradation in the upper instrumentation conduit and supports: brackets, clamps, terminal blocks, and conduit straps was determined to be “Low” by the expert panel. Failure of the component may impact the reliability of the core exit thermocouple(s). Failure or deviations of the thermocouple signal would be detected during normal plant operation. The primary concern with failure was identified as a loose part. Since the plants are upflow plants, the path for a loose part would be to travel to the steam generator where it would likely be detected. No safety impact was identified. The potential impact was

determined to be only financial. Consistent with the generic MRP-191, Table 6-3 ranking criteria, this assessment was assigned a “Low” categorization for conditional damage likelihood.

The process and results of the expert panel evaluation are summarized as follows;

- Followed the guidance and requirements of MRP-191, Section 6, including requiring 100 percent panel consensus on basis statements and conclusions.
- Considered all potential degradation mechanisms for reactor internals and screened-in an additional mechanism as a result of the material variance: thermal aging embrittlement
- Failure likelihood ranking was assessed and assigned: Low
- Damage likelihood ranking was assessed and assigned: Low
- FMECA Group was assessed and assigned: 1

Based on these results, the expert panel concluded that there was no impact on and no change required to the current aging management strategy for the upper instrumentation conduit and supports: brackets, clamps, terminal blocks, and conduit straps as a result of the material variance from the MRP-191 evaluation. The component was deemed to have minimal likelihood of failure; thus the component was assigned to MRP-191 Category A, which equates to the “No Additional Measures” inspection category.

RAI B.2.1.7-2, MRP-227A Analyses for Byron upper support plate assemblies (017)

Applicability: Byron Units 1 and 2

Background:

LRA Appendix C discusses the applicant's responses to A/LAI No. 2 and No. 7. In its responses, the applicant identified two components that were fabricated of different materials than those considered in MRP-227-A. Specifically, the applicant indicated that the upper support plate assembly – upper support plate, flange and upper support ring at Byron, Units 1 and 2 was fabricated from CASS rather than forged Type 304 stainless steel. The applicant stated that due to the material difference in these components a FMECA was performed.

For the upper support plate assembly: upper support plate, flange, and upper support ring or skirt installed in Byron, Units 1 and 2, the FMECA determined that the upper support plate was "Non-Category A;" thus, further evaluation is required for plant-specific disposition. The applicant explained in its response to A/LAI No. 2 that, based on the certified material test reports (CMTRs) and use of guidance in NRC letter "License Renewal Issue No. 98-0030, Thermal Aging Embrittlement of Cast Austenitic Stainless Steel Components," dated May 19, 2000, the single piece castings, which include the upper support plate at Byron, Units 1 and 2, are not susceptible to loss of fracture toughness due to thermal aging embrittlement. As a result, the applicant determined that the upper support plate was categorized as a "No Additional Measures" component consistent with its original categorization in MRP-227-A.

Issue:

The staff noted that the details and bases for the applicant's FMECA and susceptibility analysis conclusion for thermal aging embrittlement were not provided for the upper support plate assembly, which are necessary to assess whether the applicant will implement an adequate aging management strategy.

The staff also noted that the applicant's response to A/LAI No. 2 focused on how thermal aging embrittlement was assessed in the FMECA process, but did not provide a discussion on how irradiation embrittlement was considered. It is not clear to the staff if or how irradiation embrittlement was considered in the applicant's FMECA for the upper support plate assembly: upper support plate, flange, and upper support ring or skirt installed in Byron, Units 1 and 2.

Request:

Applicable to the upper support plate assembly: upper support plate, flange, and upper support ring or skirt installed in Byron, Units 1 and 2:

1. Describe and justify how loss of fracture toughness due to irradiation embrittlement was considered in the FMECA. If irradiation embrittlement was not considered in the FMECA, justify why it was not considered.
2. Describe in detail and justify the susceptibility evaluation performed for the upper support plate that utilized the CMTRs and guidance in the NRC letter dated May 19, 2000, to determine that the single piece castings for the upper support plate assembly are not susceptible to thermal aging embrittlement. The justification should address, but

is not limited to, the method in which delta ferrite content was calculated, the calculated delta ferrite content based on the CMTRs, and the consideration of niobium, if applicable.

Exelon Response:

1. The potential for loss of fracture toughness due to irradiation embrittlement was considered during the FMECA of the Byron Station, Units 1 and 2, Upper Support Plate Assembly: Upper support plate, Flange, and Upper support ring or skirt. Based on component location and projected neutron fluence, the threshold for the inclusion of loss of fracture toughness due to irradiation embrittlement as a degradation mechanism was not met. The cast upper support plate is located in the reactor vessel flange/reactor vessel head region of the reactor vessel. The projected 60-year fluence of components in this region of the reactor vessel is less than 1×10^{17} n/cm² (E > 1.0 Mev), which is below the screening threshold for the aging degradation mechanism.
2. The loss of fracture toughness due to thermal aging embrittlement susceptibility evaluations for the Byron Station, Units 1 and 2, cast upper support plates were performed using the guidance provided in NRC letter of May 19, 2000, "License Renewal Issue No. 98-0030, Thermal Aging Embrittlement of Cast austenitic Stainless Steel Components" (NRC ADAMS Accession No. ML003717179). The Byron Station, Units 1 and 2, upper support plate are fabricated from ASTM A351 Grade CF8 (low molybdenum) cast austenitic stainless steel (CASS). The upper support plates are conservatively assumed to have been static cast. As discussed above, the projected 60-year fluence for the upper support plate is less than 1×10^{17} n/cm² (E > 1.0 Mev). Susceptibility screenings were performed using the calculated delta ferrite content as described in the referenced NRC letter. The calculated delta ferrite content was determined using certified material test report (CMTR) data and the Hull's equivalent factors as described in U.S. Nuclear Regulatory Commission Contractor Report NUREG/CR-4513, Rev. 1, "Estimation of Fracture Toughness of Cast Stainless Steels During Thermal Aging in LWR Systems," August 1994 (NRC ADAMS Accession No. ML052360554). The calculated delta ferrite content for the Byron Station, Units 1 and 2, cast upper support plates were calculated to be less than or equal to 20 percent which screened the components as not susceptible to loss of fracture toughness due to thermal aging embrittlement. ASTM A351 Grade CF8 Chemical Requirements do not specify a value for niobium; thus, it would not have been intentionally added to the melt and is not listed on the upper support plates' CMTRs.

RAI B.2.1.7-4, Evaluating RVI components with existing CUFs for effects of reactor water environment (017)

Applicability: Byron and Braidwood Stations

Background:

LRA Appendix C discusses the applicant's response to A/LAI No. 8, Item No. 5. The applicant's response states that the Fatigue Monitoring Program will be enhanced to evaluate the effects of the reactor coolant system water environment on the reactor vessel internal components with existing fatigue cumulative usage factor (CUF) analyses to satisfy the evaluation requirements ASME Code, Section III, Subsections NG-2160 and NG-3121. In addition, during its audit, the staff noted that the "scope of program" program element in the applicant's program basis document for the Fatigue Monitoring Program indicates that the resulting CUF_{en} values will not exceed 1.0 for these evaluations.

Issue:

The staff noted that, based on the applicant's response to A/LAI No.8, Item No. 5, it is not clear how the applicant is addressing effects of the reactor coolant system water environment on the reactor vessel internal components with existing fatigue CUF analyses. The applicant did not identify the specific approach or method by which the Fatigue Monitoring Program will evaluate the reactor vessel internal components with existing fatigue CUF analyses to address the effects of reactor coolant system water environment.

Request:

1. Indicate the reactor vessel internals (RVI) components with existing CUF analyses for which the Fatigue Monitoring Program will evaluate the effects of reactor coolant system water environment and provide the associated material type and CUF value for each component.
2. Describe and justify the approach and method that will be used to address the effects of reactor coolant system water environment on the reactor vessel internal components with existing fatigue CUF analyses.

Exelon Response:

1. The RVI components with existing cumulative usage factor (CUF) analyses for which the Fatigue Monitoring Program will evaluate the effects of reactor coolant system water environment and the associated material type and CUF values are presented in the following table.

Component	Cumulative Usage Factor	Material
Upper Core Plate	0.108	Stainless Steel
Upper Core Plate Alignment Pins	0.391	Stainless Steel
Upper Support Plate	0.185	Stainless Steel *
Baffle Plate	0.032	Stainless Steel
Core Barrel Nozzle	0.413	Stainless Steel

Lower Radial Restraints	0.215	Nickel Alloy
Lower Core Plate	0.000	Stainless Steel
Lower Support Columns	0.267	Stainless Steel

*Byron Station Units 1 and 2; cast austenitic stainless steel, Braidwood Station Units 1 and 2; forged stainless steel.

2. The approach and method to be utilized to address the effects of reactor coolant system water environment on the reactor vessel internal components with existing fatigue CUF analyses will be consistent with that used to evaluate reactor coolant pressure boundary components in section 4.3.4, "Class 1 Component Fatigue Analyses Supporting GSI-190 Closure", of the LRA. Each of the components with existing fatigue CUF analyses in the table above will be evaluated by applying environmental fatigue multipliers determined in accordance with the methodologies in NUREG/CR-5704, "Effects of LWR Coolant Environments on Fatigue Design Curves of Austenitic Stainless Steels", for austenitic stainless steel components or NUREG/CR-6909, "Effects of LWR Coolant Environments on the Fatigue Life of Reactor Materials", for nickel alloy components. This approach and methodology to address the effects of the reactor coolant environment on component fatigue life is described and justified in NUREG-1801, Revision 2, Section X.M1, "Fatigue Monitoring".

RAI B.2.1.7-5, Managing aging effects beyond those mentioned in MRP-227-A (017)

Applicability: Byron and Braidwood Stations

Background:

LRA Appendix C provides the pressurized-water reactor (PWR) Vessel Internals Inspection Plan that is outlined in Tables A through D:

- Table A specifies the vessel internal components classified as Primary components and is based on MRP-227-A, Table 4.3.
- Table B specifies the vessel internal components classified as Expansion components and is based on MRP-227-A, Table 4.6.
- Table C specifies the examination acceptance and expansion criteria and is based on MRP-227-A, Table 5.3.
- Table D specifies the components that are classified as Existing Program components.

The staff noted that, although LRA Appendix C, Tables A and B, are based on MRP-227-A, they include the management of aging effects that were not identified in MRP-227-A, Tables 4.3 and 4.6. In addition, the staff noted that LRA Appendix C, Table C, provides the “examination acceptance criteria,” “expansion criteria,” and “additional examination acceptance criteria” for Primary and Expansion components, but only for those aging effects that were identified and evaluated in MRP-227-A, Tables 4.3 and 4.6.

Issue:

For example, Table 4-3 of MRP-227-A identifies that the control rod guide tube assembly: guide plates (cards) are managed for loss of material due to wear as a “Primary” component. However, Table A of LRA Appendix C, identifies that the control rod guide tube assembly: guide plates (cards) are managed for loss of material, cracking, loss of fracture toughness and changes in dimensions. The staff noted that this is only an example and is not the only instance in which the applicant proposed the management of aging effects beyond those discussed in MRP-227-A. Since the applicant has identified aging effects that were not addressed in MRP-227-A, Tables 4.3 and 4.6, the staff noted that the program may not currently include suitable inspections and proper acceptance and examination criteria to manage these additional aging effects.

The applicant’s proposal to manage these additional aging effects not addressed in MRP-227-A is conservative; however, the staff noted that in order for the applicant’s program to adequately manage these additional aging effects it is necessary for the program and inspection plan to establish the appropriate inspection, acceptance and examination criteria.

Request:

For those additional effects that are not addressed in MRP-227-A but are outlined in the Vessel Internals Inspection Plan, establish and justify that appropriate inspections will be performed to adequately manage these additional aging effects. Specifically, consider in the justification that a proper inspection technique is used and appropriate examination acceptance criteria, expansion criteria and additional examination acceptance criteria are established for a particular aging effect.

Exelon Response:

Additional aging effects not addressed by the inspection recommendations contained in MRP-227-A, Tables 4-3 and 4-6 were included in the Byron and Braidwood PWR Vessel Internals Inspection Plan as part of the project screening process. The impact of these additional aging effects were evaluated for the associated component in MRP-227-A which determined that the susceptibility to degradation, the likelihood of failure, or consequences of failure of the components due to the additional aging effects were of minimal significance.

The project screening process included all aging effects regardless of significance. Although the impact of an aging effect was determined to be of minimal significance, it still may occur. Therefore, if a component is being inspected for more significant aging effects, any indication that a lesser significant aging effect is occurring should be noted and evaluated. Since no significant impact due to the additional aging effects is expected, pre-defined acceptance criteria and expansion criteria are not necessary. However, the additional aging effects will be part of the program procedures implementing the PWR vessel internals inspections.

Clarifying notes are added to the Byron and Braidwood PWR Vessel Internals Inspection Plan, LRA Appendix C, Tables A and B. In addition, Note 1 for the Baffle-to Former Assembly: Accessible Baffle-to-Former Bolts item in Table A is added to address MRP-227-A, Table 4-3, Note 6. Changes to LRA Appendix C are included in Enclosure B.

RAI B.2.1.7-6, Aging management for RVI clevis insert bolts (017)

Applicability: Byron and Braidwood Stations

Background:

LRA Table 3.1.2-3, Reactor Vessel Internals, indicates that the clevis insert bolts are nickel alloy and that cracking will be managed by the PWR Vessel Internals Program. In addition, the staff noted that Table D in LRA Appendix C indicates that the clevis insert bolts are managed by part of the inspections performed in accordance with ASME Code Section XI, Category B-N-3. Appendix A to MRP-227-A indicates that failures of Alloy X-750, precipitation-hardenable nickel-chromium alloy, clevis insert bolts were reported by one Westinghouse-designed plant in 2010 and suspected to be a result of primary water stress cracking corrosion.

The staff noted that the only aging mechanism requiring management by MRP-227-A for the clevis insert bolts is wear, and the bolts are categorized as an “Existing Programs” component. Thus, under MRP-227-A, the clevis insert bolts will be inspected in accordance with the ASME Code Section XI Inservice Inspection Program to manage the effects due to wear only.

Issue:

The staff noted that the ASME Code Section XI specifies a VT-3 visual inspection for the clevis insert bolts, which may not be adequate to detect cracking before bolt failure occurs. In addition, it is not clear to the staff whether this operating experience is applicable to the applicant and whether the applicant’s PWR Vessel Internals AMP will need to be modified to account for this operating experience.

Request:

1. Specify the fabrication material, including any applicable heat treatment, for the clevis insert bolts at Byron and Braidwood, Units 1 and 2.
2. Discuss and justify whether the operating experience associated with cracking of the clevis insert bolts (discussed above) is applicable to Byron and Braidwood Stations, Units 1 and 2.
 - o If applicable, discuss and justify how your PWR Vessel Internals Program will be augmented to require an inspection of the clevis insert bolts capable of detecting cracking. If the PWR Vessel Internals Program will not be augmented, provide a technical justification for the adequacy of the existing VT-3 visual inspection to detect cracking before it results in clevis insert bolt failure.

Exelon Response:

1. The clevis insert bolts used at Byron and Braidwood Stations, Units 1 and 2, are fabricated from Alloy X-750, SA-637 (currently specified as SB-637), Grade 688, Type 2. Heat treatment applied is as follows:
 - Hot worked.
 - Solution treatment at $1800 \pm 25^{\circ}\text{F}$ ($982 \pm 14^{\circ}\text{C}$) for a 1/2 hour minimum, cooled at a rate equivalent to air cool or faster.

- Precipitation hardened at $1350 \pm 15^\circ\text{F}$ ($732 \pm 8^\circ\text{C}$), hold for 8 hours, furnace cool to $1150 \pm 15^\circ\text{F}$ ($621 \pm 8^\circ\text{C}$), hold until total precipitation heat treatment has reached 18 hours, air cool.

This heat treatment is similar to that which is typically referred to as low-temperature annealed and aged condition (BH).

2. The operating experience associated with the cracking of clevis insert bolts in 2010 at another Westinghouse-designed plant is not directly applicable to Byron and Braidwood Stations, Units 1 and 2, based on the following differences.
 - The heat treatment of the failed clevis insert bolts at the other plant is different from the clevis insert bolts used at Byron and Braidwood Stations, Units 1 and 2. The failed clevis insert bolts were heat treated using a process similar to the equalized and aged condition (AH) process that has been proven to be susceptible to PWSCC in the control rod guide tube support pins (split pins). The Byron and Braidwood, Units 1 and 2, clevis insert bolts were heat treated using a process similar to the low-temperature annealed and aged condition (BH) process (see description above).
 - The clevis insert designs are different (see figures below).
 - The clevis insert used in the plant that had the clevis insert bolt failures in 2010 is a Westinghouse Type 4 (see figure below). The Type 4 clevis insert is a winged design where the clevis insert is shrink fitted (interference fit) into the reactor vessel lower radial support clevis, then bolted and doweled with four (4) bolts and one (1) dowel pin on each side of the clevis opening (total eight (8) bolts, two (2) dowels per insert).
 - The clevis insert design used at Byron and Braidwood Stations, Units 1 and 2 is a Westinghouse Type 2 (see figure below). The Type 2 clevis insert is a U-design where the clevis insert is shrink fitted (interference fit) into the reactor vessel lower radial support clevis, then bolted and doweled with eight (8) bolts and two (2) dowel pins in two (2) vertical rows in the middle of the clevis insert opening.
 - There are no known failures of clevis insert bolts in plants that use the clevis insert design (Westinghouse Type 2) and heat treatment used at Byron and Braidwood, Unit 1 and 2.

The failed clevis insert bolt industry operating experience was entered into the Byron and Braidwood Stations corrective action program. Reviews of the last ASME Section XI inservice inspection results confirmed that there were no documented indications of clevis insert wear or missing lock bars.

The susceptibility of Alloy X-750 to PWSCC and low-temperature crack propagation may have been a contributor to the observed degradation detected in 2010; however, at this time, the root cause analysis of the event has not been completed. Alloy X-750 heat treated using the AH process is known to be susceptible to PWSCC. The Alloy X-750 material used at Byron and Braidwood Stations, Units 1 and 2 for clevis insert bolts is not heat treatment condition AH as described above.

The cracking of clevis insert bolts in 2010 at another Westinghouse-designed plant is not directly applicable to Byron and Braidwood Stations, Units 1 and 2. Therefore, the Byron and Braidwood PWR Vessel Internals program is not planned to be augmented to provide inspections capable of detecting cracking of the clevis insert bolts. However, industry operating experience, such as the ongoing root cause analysis of the 2010 event at another Westinghouse-designed plant, will continue to be evaluated for applicability as part of the operating experience program at Byron and Braidwood Stations, Units 1 and 2. The existing examinations specified in ASME Section XI and MRP-227-A are considered adequate until industry operating experience prompts additional inspection requirements.

Clevis Insert Design #4

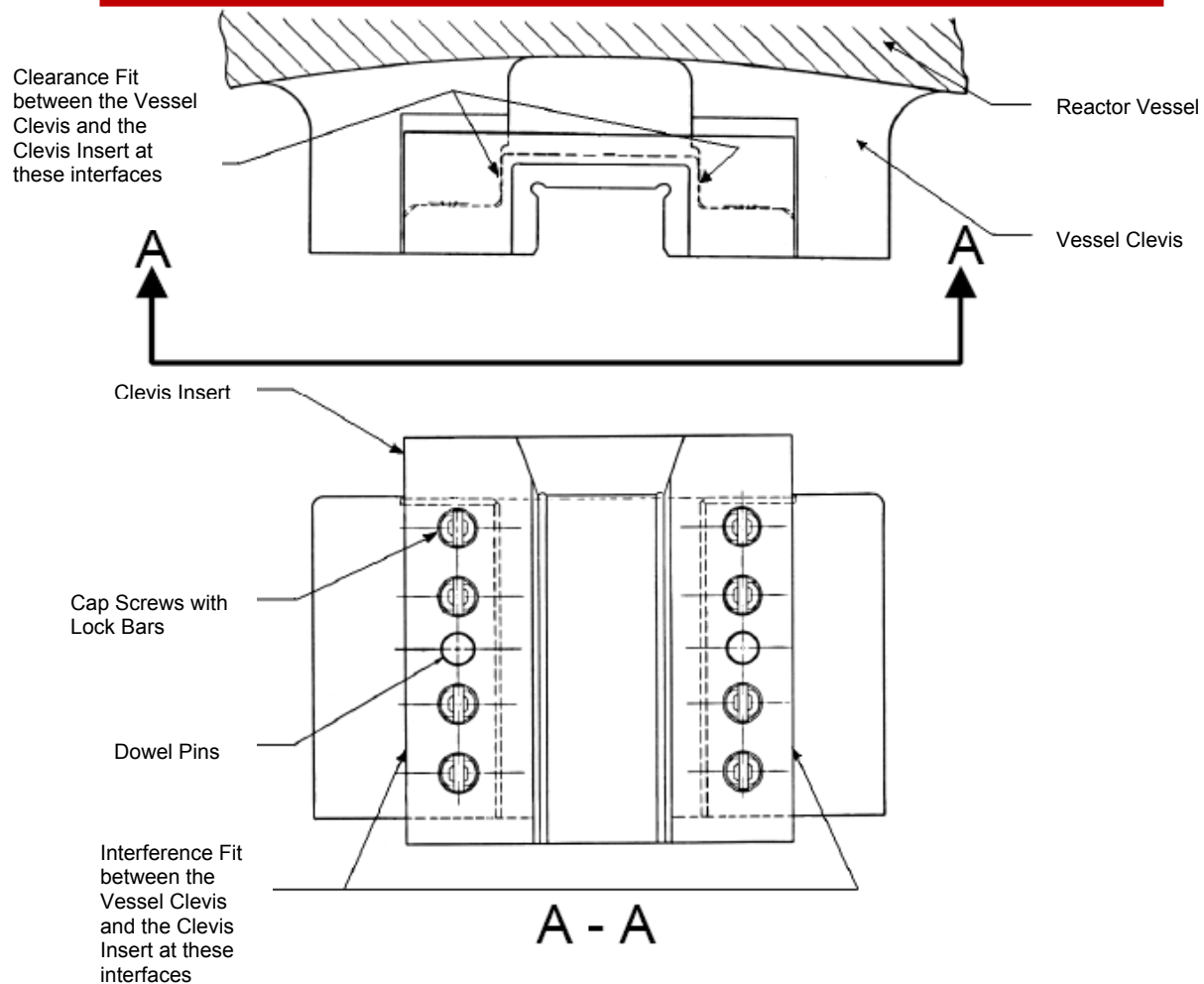

Clevis Insert Design #2

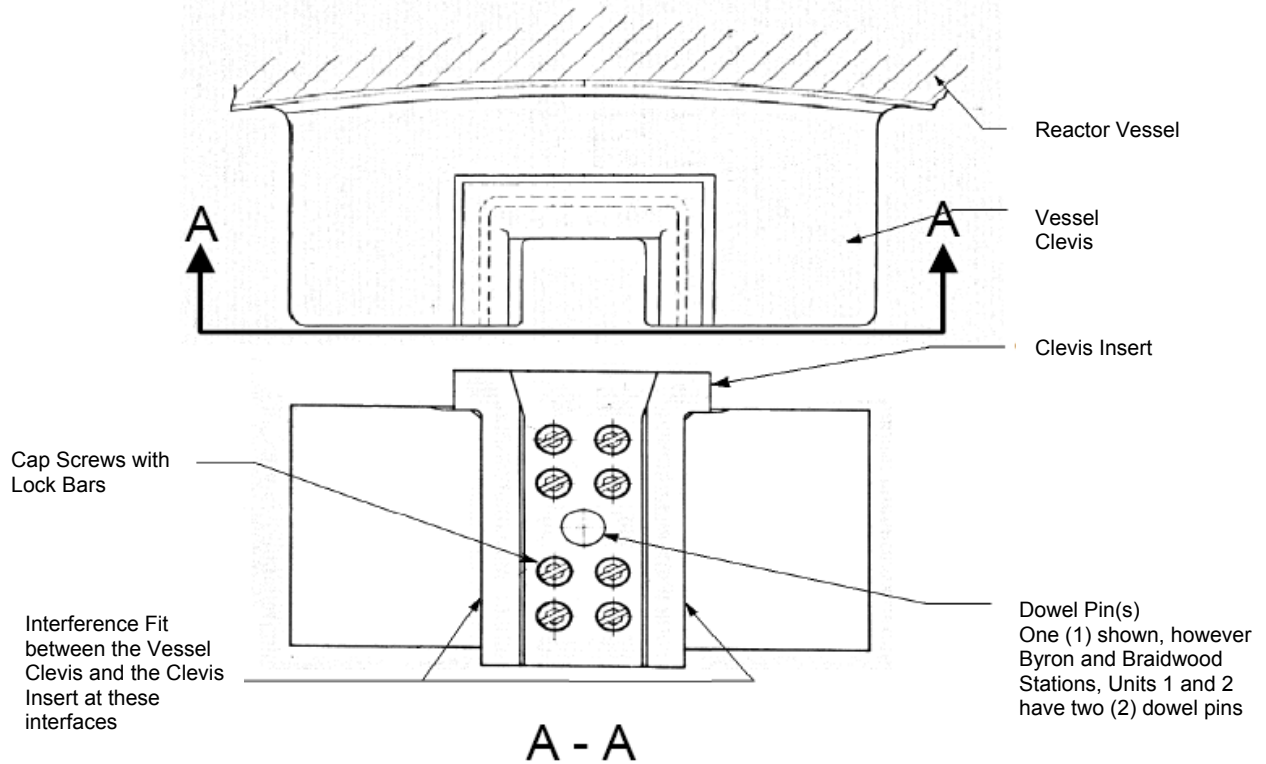

RAI B.2.1.5-1, Missing operating experience from LRA concerning loss of material due to wear in CRDM nozzles (011)

Applicability: Byron and Braidwood Stations

Background:

LRA Section B.2.1.5 states that the Cracking of Nickel-Alloy Components and Loss of Material Due to Boric Acid-Induced Corrosion in Reactor Coolant Pressure Boundary Components Program is consistent with GALL Report AMP XI.M11B, which includes the examinations of ASME Code Case N-729-1 as required by 10 CFR Part 50.55a. During the audit, the staff noted that the applicant performed ultrasonic testing (UT) examination of the CRDM nozzles at Byron, Unit 1, in 2011, in accordance with ASME Code Case N-729-1. During the UT examination, the applicant found that CRDM nozzle nos. 4 and 8 experienced wear as a result of interactions between the CRDM nozzle thermal sleeve centering pads and the CRDM nozzle (wall).

In addition, the staff noted that the applicant's operating experience also indicates that loss of UT data occurred above the J-groove welds on these penetration nozzles because water couplant was not able to make up the gap between the UT blade probe and the CRDM nozzle in these wear areas. The applicant's operating experience further indicates that it was not possible to determine the exact thickness values of the CRDM nozzles in the wear area since the zero-degree UT probe, which could measure the nozzle thickness, could not receive a UT signal due to the water couplant issue described above.

Issue:

LRA Section B.2.1.5 does not describe this operating experience, which indicates a loss of material in the CRDM nozzles due to wear caused by the thermal sleeve centering pads. Therefore, the staff needs additional information to confirm that this loss of material of CRDM nozzles due to wear by the centering pads will be adequately managed for the period of extended operation. In addition, the staff needs to clarify whether and how the applicant resolved the water couplant issue (i.e., loss of UT data due to the absence of water couplant in the gap between the UT probe and the CRDM nozzle near these wear areas during the UT examination).

Request:

1. Provide the following baseline information related to the observed wear indications of the CRDM penetration nozzles due to the interactions between the CRDM nozzle thermal sleeve centering pads and the CRDM nozzle walls.
 - a) The total number of the CRDM penetration nozzles for each unit, and how many head penetration nozzles have been found to have these wear indications for each unit of the Byron and Braidwood Stations.
 - b) The maximum depth of the wear indications, if measured, in comparison with the CRDM nozzle wall thickness, for each unit.

- c) Clarification of whether these wear indications of the nozzles (from the centering pads) are located at reactor coolant pressure boundary locations.
 - d) The applicant's acceptance basis for the continued operation with the wear indications, including the acceptable wear depth that was determined in the applicant's analysis.
 - e) Clarification of whether all wear indications are located in the volume or extent of the examination specified in the program (e.g., the volumetric examination of ASME Code Case N-729-1).
2. Clarify whether this wear may occur for other types of reactor vessel head nozzles (e.g., reactor vessel level indication system penetration nozzles). If so, provide information in response to Request 1 as applied to the other types of reactor vessel head nozzles.
 3. Describe how the loss of material due to this wear of reactor vessel head penetration nozzles will be monitored and managed. As part of the response, describe the inspection method, scope, and frequency of the examinations for managing loss of material due to wear of these nozzles.
 4. Clarify whether and how the water couplant issue was resolved (i.e., loss of UT data due to the absence of water couplant in the gap between the UT probe and the reactor vessel head nozzle near the wear locations during the UT examination). As part of the response, describe the extent of loss of the UT data (e.g., the percentage of the UT examination volume that could not be appropriately examined for cracking and loss of material).

If the issue has not been resolved, provide additional information to justify why loss of UT data near the wear locations is acceptable in managing cracking and wear of the reactor vessel head nozzles for the period of extended operation.

5. Identify all program enhancements and additional aging management review items as necessary for aging management. In addition, ensure that the LRA is consistent with the applicant's response.

Exelon Response:

1.
 - a) There are a total of 78 control rod drive mechanisms (CRDM) penetration nozzles on the reactor vessel head on each unit with 55 CRDM penetrations nozzle locations having thermal sleeves. These 55 locations include 53 penetrations with control rod drive assemblies and two (2) penetrations with reactor vessel level instrumentation (RVLIS) for removable heated junction thermocouples (HJTC). During ultrasonic testing (UT) of the CRDM penetration nozzle J-groove welds, wear indications have been observed but could not be measured on the nine (9) CRDM penetration nozzles (P1 through P9) near the center of the reactor vessel head on each Byron and Braidwood Stations, Units 1 and 2. The wear on the other CRDM penetration nozzles that contain thermal sleeves, outside of the reactor vessel head central region, is outside of the volume examined during the J-groove weld examinations and cannot be measured directly with the existing NDE techniques but can be inferred from the thermal sleeve wear only. Thermal sleeve wear at the exit of the CRDM penetration nozzle indicates that the centering tabs are causing wear on the CRDM penetration nozzle.

- b) CRDM penetration nozzle wear indications were initially noted during the J-groove weld examinations on the CRDM penetration nozzles with thermal sleeves near the central region of the reactor vessel head. The actual depth of these indications could not be measured with the existing techniques. Three centering pads extend 0.1075 inches, which is the pad thickness, beyond the outside diameter of the thermal sleeve. The wall thickness of a CRDM penetration nozzle is 0.625 inches at the thinnest location.
- c) The wear indications (from the centering pads) are located inside the nickel alloy CRDM penetration nozzles, which are part of the reactor coolant pressure boundary (i.e., ASME Section III Class 1 pressure boundary).
- d) Evaluations have been performed for three of the four units for the CRDM penetration nozzle wear which allow two (2) cycles of operation without additional inspections. The evaluation for the fourth unit, Byron Unit 2, is presently in progress and is expected to be completed by first quarter 2014 with similar results. The evaluations for continued operations conservatively considered the maximum possible reduced CRDM penetration nozzle wall thickness due to wear (i.e., maximum wear depth) and determined that reasonable margin existed to allow two cycles of operation and allow time for more detailed evaluations to be completed. The assumed maximum wear depth is the maximum possible penetration nozzle wear of 0.1075 inches, which is the distance the centering pad extends from the outside diameter of the thermal sleeve.

The evaluations performed by Westinghouse for the current condition of the units base the acceptability of the wear on the calculations considering the primary stresses, primary plus secondary (P+Q) stress intensity ranges, and fatigue usage assessments. These evaluations were based on the low CRDM penetration nozzle cumulative fatigue usage factors at Byron and Braidwood (0.021 compared to a limit of 1.0) and the conservative load combinations and reduction in wall thickness assumed in the evaluation. The limiting stress location in the CRDM nozzle is at the top of the J-groove weld. Therefore, the CRDM penetration nozzles located in the center of the reactor vessel head with reduced wall thickness become the limiting locations, since the wear in these nozzles is adjacent to the J-groove weld. The presence of wear in the center region penetration nozzles can be observed (not measured) during the J-groove weld examinations, and therefore the maximum possible wear depth of 0.1075 inches was assumed in the evaluation.

- e) Of the 55 CRDM penetration nozzles with thermal sleeves, only the center nine (9) (P1-P9) on each unit are within the examination volume (J-groove weld examination) of the reactor vessel head. The 55 thermal sleeve centering pads are at the same height (approximately 23 inches below the top of the CRDM adapter) on each of the CRDM penetration nozzles.
2. Response 1 above addresses any CRDM penetration nozzle (55) that contains thermal sleeves which are the penetrations with control rod drive assemblies and RVLIS with removable heated junction thermocouples. Otherwise, there are no other types of reactor vessel head penetration nozzles affected by loss of material due to wear.
 3. As described in 1d, Exelon is planning to manage the CRDM penetration nozzles loss of material due to thermal sleeve centering pad wear by an analysis evaluating future operation without any required examinations. Westinghouse is presently developing a

bounding analysis for Byron and Braidwood Stations which is expected to allow operation until the end of the period of extended operation. This analysis is currently under development for the industry including Byron and Braidwood and will consider the maximum credible wear depth of 0.1075 inches, minimum CRDM penetration nozzle wall thickness, and all applicable design basis loads. The analysis will include a detailed ASME Code evaluation of the CRDM housing with a reduced wall thickness using the bounding CRDM loads and transients. All ASME Code stress categories will be evaluated utilizing a finite element analysis and will explicitly consider all conditions to which the CRDM housing is subjected during normal and upset conditions. The analysis is scheduled to be completed in 2014. There is confidence, upon completion of the Westinghouse industry analysis, that the maximum possible penetration nozzle wear of 0.1075 inches will be acceptable for the period of extended operation.

4. The water couplant issue at Byron Unit 1 was resolved by the development of an improved probe, which was able to provide essentially 100 percent examination coverage during the subsequent inspection in the Fall 2012 refueling outage. The improved probe contains two (2) sets of transducers, one (1) set of transducers for axial flaws, and one (1) set of transducers for circumferential flaws. The probe used previously contained only one (1) set of transducers for circumferential indications.

The Code Case N-729-1 interpretation of 100 percent data acquired is similar to what the ASME Section XI Code uses as the basis to state that essentially 100 percent coverage of the required volume has been obtained. The standard definition for "essentially 100 percent" examination standard is greater than 90 percent coverage.

On Byron Unit 1 during the 78 J-groove examinations in March 2011, the examination coverage on both the P4 (98.3%, 1.7% data loss) and the P8 (92.9%, 7.1% data loss) CRDM penetrations was less than 100 percent, but met the greater than 90 percent threshold for coverage in accordance with the ASME Section XI code. The loss of ultrasonic testing (UT) data coverage was addressed by the post examination data acquisition evaluation process in accordance with the inservice inspection procedures.

The following Byron Unit 1 outage in Fall 2012, the J-groove examinations were conducted again on both the P4 (99.8%) and the P8 (100%) CRDM penetrations. Both J-groove weld examinations had significantly improved coverage due to the improved UT probe head used for the examinations.

Similar ultrasonic testing coverage issues were documented in the corrective action program on Braidwood, Units 1 and 2, for the inservice inspections of the J-groove welds during the Spring 2012 and Spring 2011 refueling outages, respectively. The examination coverage on these inspections was greater than 90 percent for all the weld inspections. Byron 2 was able to achieve 100 percent coverage during the Fall 2011 refueling outage for the inservice inspection activities on the J-groove welds with the original probe design indicating minimal centering pad wear.

5. No additional program enhancements or aging management review items are necessary for the aging management of CRDM penetration nozzles aging mechanism of loss of material due to wear. The aging management for wear on the CRDM penetration nozzle components will be managed as part of the ASME Section XI (B.2.1.1) aging management program. Westinghouse is presently developing a bounding analysis for Byron and

Braidwood which is expected to allow operation until the end of the period of extended operation. The LRA is consistent with this response.

RAI B.2.1.5-2, Loss of material from thermal sleeves of reactor vessel head nozzles (011)

Applicability: Byron and Braidwood Stations

Background:

As discussed in RAI B.2.1.5-1, during the audit, the staff noted that the applicant performed UT examinations of the CRDM nozzles at Byron Station Unit 1 in 2011, in accordance with ASME Code Case N-729-1. The UT examination found that CRDM nozzle Nos. 4 and 8 experienced wear as a result of the interactions between CRDM nozzles and CRDM nozzle thermal sleeves. LRA Table 3.1.2-2 also indicates that the thermal sleeves of reactor vessel head nozzles are subject to loss of material due to wear.

In addition, the staff noted that the thermal sleeves of reactor vessel head nozzles perform the following functions which significantly contribute to safety: (1) shielding the nozzles from thermal transients, (2) providing a lead-in for the rod cluster control assembly (RCCA) drive rods into the CRDM nozzles, and (3) protecting the RCCA drive rods from the head cooling spray cross flow in the reactor vessel upper head plenum region.

Issue:

The staff needs additional information to clarify how the applicant will monitor and manage loss of material due to wear of the reactor vessel head nozzle thermal sleeves.

Request:

1. Describe for each unit which reactor vessel head nozzles have a thermal sleeve that is subject to loss of material due to wear.
2. In addition, clarify how loss of material due to wear will be monitored and managed for these thermal sleeves. As part of the response, describe the inspection method, scope, and frequency of the examinations for managing the loss of material for the reactor vessel head thermal sleeves.

Exelon Response:

1. There are a total of 78 control rod drive mechanisms (CRDM) penetration nozzles in the reactor vessel head on each unit with 55 CRDM penetrations having thermal sleeves. These 55 locations include 53 penetrations with control rod drive assemblies and two (2) penetrations with reactor vessel level instrumentation (RVLIS) for removable heated junction thermocouples. The remaining 23 CRDM penetrations do not have thermal sleeves installed.
2. The wear on the thermal sleeves was initially noted in 2007 at a Westinghouse plant. Subsequently, Westinghouse issued technical bulletin, TB-07-2, "Reactor Vessel Head Adapter Thermal Sleeve Wear," requiring the units to examine the thermal sleeves in the outer two concentric rows on the reactor vessel head. An engineering evaluation was performed that determined the minimum wall thicknesses to maintain thermal sleeve structural integrity at Byron and Braidwood. This evaluation included a worst-case analysis for the maximum wear that could be expected on the thermal sleeves. The analysis also

addresses the failure effects including a complete separation of the thermal sleeve. Based on the current examination results at Byron and Braidwood, none of the evaluated thermal sleeve indications approach the minimum wall thickness (0.061 inches), and no thermal sleeves are expected to separate on any rodded (53) or RVLIS (2) penetration. The evaluation also determined that rod drop times would be maintained within the rod drop time technical specification limit, even with a complete separation of a thermal sleeve.

The inspection methods will be those specified in WCAP-16911-P, "Reactor Vessel Head Thermal Sleeve Wear Evaluation for Westinghouse Domestic Plants", which include volumetric (UT), physical measurement, or visual examinations.

The initial recommended scope of thermal sleeve visual inspections in accordance with the technical bulletin was the outer two concentric rows (34) on each unit at Byron and Braidwood, however, all 55 thermal sleeves were examined visually for loss of material due to wear. As a result of the initial visual examinations, the five (5) thermal sleeves with the worst wear were selected to be examined with ultrasonic testing (UT) in order to obtain measurements of the wear indications. The scope of examinations per unit is to UT these five leading thermal sleeves with the worst wear found to date. The plan for managing thermal sleeve wear is to obtain measured (UT) wear data points on each unit at the designated five (5) thermal sleeve locations during three different outages when Reactor Vessel Head penetration weld examinations are performed. The frequency of the penetration weld examinations is calculated based on the Code Case N-729-1, "Alternative Examination Requirements for PWR Reactor Vessel Upper Heads With Nozzles Having Pressure-Retaining Partial-Penetration Welds Section XI, Division 1." The frequencies of weld examinations differ among the Byron and Braidwood units based on operating history and J-groove weld examination results. The inspection frequency for the reactor vessel head thermal sleeve loss of material due to wear will be re-evaluated after the accumulation of the three data points on the five worst thermal sleeves. Using the guidance provided in WCAP-16911-P the calculation of future inspections frequencies will be based on the operational time extension curve methodology (i.e., wear rate determination), which utilizes non-linear analysis dynamic techniques. Non-linear dynamic analysis techniques are incorporated to analyze the variation in wear rate as the clearances at the centering pads increase. Based on the results obtained from the calculations, the required frequency will be determined for the next inspections. Byron and Braidwood plan to implement the examination schedule in accordance with the WCAP-16911-P.

RAI B.2.1.19-1, Reactor vessel surveillance withdrawal schedules (032)

Applicability: Byron and Braidwood Stations

Background:

Appendix H to 10 CFR Part 50 states, "Surveillance specimen capsules must be located near the inside vessel wall in the beltline region so that the specimen irradiation history duplicates, to the extent practicable within the physical constraints of the system, the neutron spectrum, temperature history, and maximum neutron fluence experienced by the reactor vessel inner surface."

GALL Report AMP XI.M31, "Reactor Vessel Surveillance Program," recommends that one capsule be withdrawn at an outage in which the capsule receives a neutron fluence of between one and two times the peak reactor vessel wall neutron fluence at the end of the period of extended operation and be tested in accordance with ASTM E185-82, "Standard Practice for Conducting Surveillance Tests for Light-Water Cooled Nuclear Power Reactor Vessels."

LRA Section B.2.1.19 describes the applicant's Reactor Vessel Surveillance Program and states:

There were six (6) specimen capsules installed in each Byron and Braidwood Stations (BBS) RPV prior to plant start-up. The capsules contain representative RPV material specimens, neutron dosimeters, and thermal monitors (eutectic alloy). All six (6) specimen capsules have been withdrawn from each of the BBS RPVs. Three (3) specimen capsules from each RPV were tested and the remaining three (3) untested specimen capsules from each RPV are currently stored in the spent fuel pool. Of the three (3) untested specimen capsules from each RPV at least one (1) untested specimen capsule has been irradiated in excess of the projected peak neutron fluence of the associated RPV at the end of the period of extended operation. Capsules that have been withdrawn will be tested as necessary to fulfill the surveillance capsule recommendations contained in ASTM 185-82 as required by 10 CFR Part 50, Appendix H.

By letter dated November 11, 2011 (ADAMS Accession No. ML113050427), Exelon provided additional information regarding the reactor vessel material surveillance program to support a license amendment request dated June 23, 2011 (ADAMS Accession No. ML111790030), for a measurement uncertainty recapture (MUR) power uprate for Byron and Braidwood. The reactor vessel surveillance capsule withdrawal schedules for Byron and Braidwood are contained in the pressure-temperature limits report (PTLR) for each unit (ADAMS Accession Nos. ML070680370, ML070240261, and ML071070447 for Braidwood, Units 1 and 2, Byron, Unit 1, and Byron Unit 2, respectively). The neutron fluence values in the PTLRs are consistent with neutron fluence values from the most recent neutron fluence surveillance capsule reports contained in Table 1

Table 1. Neutron Fluence Values for Surveillance Capsule Reports/PTLRs and MUR RAI Response Submittal Dated November 1, 2011

Plant, Unit	Capsule ID	Fast Neutron Fluence (E > 1.0 MeV)	
		Capsule Report/PTLR (n/cm ²)	Submittal 11/01/2011 (n/cm ²)
Braidwood, 1	W	2.09 x 10 ¹⁹	1.98 x 10 ¹⁹
Braidwood, 2	W	2.25 x 10 ¹⁹	2.07 x 10 ¹⁹
Byron, 1	W	2.43 x 10 ¹⁹	2.26 x 10 ¹⁹
Byron, 2	X	2.30 x 10 ¹⁹	2.18 x 10 ¹⁹

Issue:

Appendix H to 10 CFR Part 50 provides requirements for reactor vessel surveillance programs. Changes to the surveillance program require NRC approval prior to implementation and must monitor changes in the fracture toughness properties resulting from the maximum neutron fluence experienced by the ferritic materials in the reactor vessel beltline. In addition, since no exceptions are identified in LRA Appendix B Section B.2.1.19 regarding the surveillance capsule withdrawal schedule, the submittal should be consistent with the GALL Report AMP XI.M31 for testing surveillance specimens from a capsule that has been exposed to a neutron fluence of between one and two times the peak reactor vessel wall neutron fluence at the end of the period of extended operation.

Request:

1. Provide an updated surveillance capsule withdrawal schedule for each unit including, but not limited to: identification of the capsule and associated neutron fluence value which will provide test results consistent with the GALL Report recommendation of a neutron fluence exposure of between one and two times the peak reactor vessel wall neutron fluence at the end of the period of extended operation, and identification of a date for the submittal of each summary technical report.
2. The neutron fluence values in Table 1 are not consistent. Specifically, the neutron fluence values in the most recently submitted surveillance capsule report for each Byron and Braidwood unit, which are identical to the neutron fluence values in the PTLR surveillance capsule withdrawal schedules, differ from the values contained in the November 1, 2011 submittal. Provide a basis for the change in neutron fluence values for each unit.

Exelon Response:

1. The Reactor Vessel Surveillance program updated surveillance capsule withdrawal schedule for each unit is as follows:

One (1) specimen capsule per reactor vessel, as designated below in Table 1, irradiated to a neutron fluence of one (1) to two (2) times the projected peak neutron fluence at the end of the period of extended operation, will be withdrawn from the spent fuel pool, tested, and the summary technical report submitted to the NRC prior to entering the associated period of extended operation.

Table 1

Reactor Vessel (Station, Unit)	Capsule ID	Capsule Fluence (n/cm ²)(E>1.0 MeV)
Byron, Unit 1	Y	3.97E+19
Byron, Unit 2	Y	4.19E+19
Braidwood, Unit 1	V	3.71E+19
Braidwood, Unit 2	V	3.73E+19

The submittal date of prior to the period of extended operation (PEO) ensures that the actual reactor vessel beltline material neutron fluence does not exceed the last specimen capsule tested neutron fluence, allowing sufficient time (0.8 to 5.4 years depending on unit, see Table 2 below) for the NRC to review the results prior to entry into the PEO.

The neutron fluence of the last tested specimen capsule, equivalent effective full power years (EFPYs), and projected EFPY at the beginning of PEO are provided in Table 2.

Table 2

Reactor Vessel (Station, Unit)	Last Tested Capsule ID	Capsule Fluence (n/cm ²)(E>1.0 MeV)	Capsule Equivalent EFPY	Projected EFPY at Beginning of PEO*	ΔEFPY between capsule and PEO**
Byron, Unit 1	W	2.26E+19	40.5	35.1	5.4
Byron, Unit 2	X	2.18E+19	39.4	36.5	2.9
Braidwood, Unit 1	W	1.98E+19	35.8	35.0	0.8
Braidwood, Unit 2	W	2.07E+19	38.0	36.4	1.6

* Assuming 100% capacity factor, lower capacity factor equates to lower EFPY.

** 1 EFPY equals 1 calendar year assuming 100% capacity factor, lower capacity factor equates to higher Δ EFPY and longer time period.

In addition during this review, the Braidwood Station, Unit 2, peak projected neutron fluence at the end of the period of extended operation was identified as being incorrectly reported as $3.19\text{E}+19$ n/cm² (E>1.0 MeV) and is corrected in Enhancement 1 and affected sections of the LRA. The peak projected neutron fluence should be $3.16\text{E}+19$ n/cm² (E>1.0 MeV) instead of $3.19\text{E}+19$ n/cm² (E>1.0 MeV).

Changes to LRA Appendix A section A.2.1.19, Appendix B section B.2.1.19, and Appendix A.5, commitment 19, are included in Enclosures B and C.

2. The neutron fluence values in the most recently submitted surveillance capsule report for each BBS unit, which are identical to the neutron fluence values in the PTLR surveillance capsule withdrawal schedules, are different from the values contained in the November 1, 2011 MUR RAI submittal due to the neutron fluence values being calculated using different NRC-approved methods. The November 1, 2011 MUR RAI submittal was in response to questions regarding the Measurement Uncertainty Recapture (MUR) License Amendment Request (LAR) submittal dated June 23, 2011 [ML111790030]. The basis for the change in method to determine neutron fluence values is technically justified in the above MUR submittals and summarized below.

The most recently submitted surveillance capsule report for each BBS unit documents the use of WCAP-14040-NP-A, Revision 2, for determining the surveillance capsule neutron fluence. WCAP-14040-NP-A, Revision 2, Section 2.2 documents the methodology used to determine neutron fluence with adjoint calculations.

The November 1, 2011 MUR RAI submittal in response to NRC Request 1, confirms the prior (most recent) surveillance capsule submittals to the NRC used a different methodology, one that was based on adjoint calculations. It further states the surveillance capsule neutron fluence calculations completed for MUR were based on the NRC-approved methodologies described in WCAP-14040-A, Revision 4, "Methodology Used to Develop Cold Overpressure Mitigating System Setpoints and RCS Heatup and Cooldown Limit Curves," and WCAP-16083-NP-A, Revision 0, "Benchmark Testing of the FERRET Code for Least Squares Evaluation of Light Water Reactor Dosimetry." These methodologies meet the requirements of Regulatory Guide 1.190, "Calculational and Dosimetry Methods for Determining Pressure Vessel Neutron Fluence," U. S. Nuclear Regulatory Commission, Office of Nuclear Regulatory Research (March 2001). WCAP-14040-A, Revision 4, documents in Section 2.2.1 the methodology used to determine neutron fluence with forward transport calculations.

The MUR LAR June 23, 2011 submittal in Sections IV.1.C.ii "Fluence Evaluation" and IV.1.C.vi "Surveillance Capsule Withdrawal Schedule" discusses the changes in neutron fluences. Specifically, Table IV.1.C.ii-1 "Peak Reactor Vessel Inner Surface Fluence", presents the effect of the change in methodology on peak neutron fluence when using WCAP-14040-NP-A (Revision 2) for the PTLR to WCAP-14040-A (Revision 4) and WCAP-16083-NP-A (Revision 0) for the MUR LAR submittal. The effects of the use of the different NRC approved methodologies associated with Revision 2 and Revision 4 of WCAP-14040 on the capsule neutron fluences are provided in Tables IV.1.C.vi-1 through 4. The capsule neutron fluences in the tables match those contained in Table 1 of this RAI and provide the basis for the change in neutron fluence values for each unit.

In summary, the differences in the neutron fluence values for all four Byron and Braidwood unit surveillance capsules are attributed to using a methodology based on adjoint calculations in accordance with NRC-approved WCAP-14040-NP-A (Revision 2) for the capsule report/PTLR versus a methodology in accordance with NRC-approved WCAP-14040-A (Revision 4) using forward transport calculations for the MUR LAR.

Enclosure B

**Byron and Braidwood Stations, Units 1 and 2
License Renewal Application (LRA) updates resulting from the responses to the
following RAIs:**

RAI B.2.1.22-1

RAI B.2.1.22-2

RAI B.3.1.1-2

RAI B.2.1.7-5

RAI B.2.1.19-1

Note: To facilitate understanding, the original LRA pages have been repeated in this Enclosure, with revisions indicated. Existing LRA text is shown in normal font. Changes are highlighted with ***bold italics*** for inserted text and ~~strikethroughs~~ for deleted text.

As a result of changes to the One-Time Inspection of ASME Code Class 1 Small Bore Piping aging management program identified in the responses to RAIs B.2.1.22-1 and B.2.1.22-2, LRA Appendix A, Section A.2.1.22, pages A-27 and A-28 is revised as shown below. Revisions are indicated with ***bold italics*** for inserted text and ~~strike throughs~~ for deleted text.

A.2.1.22 One-Time Inspection of ASME Code Class 1 Small-Bore Piping

The One-Time Inspection of ASME Code Class 1 Small-Bore Piping aging management program is a new condition monitoring program that will manage the aging effect of cracking in ASME Code Class 1 small-bore piping that is less than nominal pipe size of four (4) inches (NPS 4), and greater than or equal to one (1) inch (NPS 1). The program, which includes pipes, fittings, branch fittings, branch connections, and all associated full penetration (butt) and partial penetration (socket) welds, will augment ASME Code, Section XI requirements. The program includes measures to verify that degradation is not occurring or aging is insignificant, thereby, either confirming that there is no need to manage aging-related degradation or validating the effectiveness of any existing program for the period of extended operation.

The program implements one-time inspection of a sample of piping full penetration (butt) and partial penetration (socket) welds that are susceptible to cracking using volumetric examinations. ~~The inspection sample size will include at least 25 butt welds and 25 socket welds within the population of program welds on each Byron and Braidwood unit.~~ ***The inspection sample size will include 10% of the socket weld population up to a maximum of 25 socket welds for each Byron and Braidwood unit and 10% of the butt weld population up to a maximum of 25 butt welds for each Byron and Braidwood unit. The socket weld sample population for Byron Unit 1 will include the socket weld on the "D" safety injection system cold leg injection line that was replaced in 1998.*** Inspection of socket welds will be performed by volumetric examination techniques demonstrated to be capable of detecting cracking. If such volumetric techniques are not available by the time of the inspections, the examination method will be by destructive testing. If destructive testing is performed, each socket weld test will be credited as equivalent to two volumetrically examined welds. Inspections required by the program will augment ASME Code, Section XI requirements, ***as applicable***.

Cracking of ASME Code Class 1 small-bore piping due to intergranular stress corrosion or fatigue due to cyclical loading has not been experienced at Byron and Braidwood Stations. Therefore, this one-time inspection program is applicable and adequate to manage this aging effect for the period of extended operation. A plant specific periodic inspection program will be implemented if evidence of cracking caused by intergranular stress corrosion or fatigue due to cyclical loading is revealed in ASME Code Class 1 small-bore piping, and design changes have not been implemented to correct the cause.

The new One-Time Inspection of ASME Code Class 1 Small-Bore Piping aging management program will be implemented prior to the period of extended operation. – One time inspections will be performed and evaluated within the six (6) year period prior to the period of extended operation.

As a result of the responses to RAIs B.2.1.22-1 and B.2.1.22-2 provided in Enclosure A of this letter, the One-Time Inspection of ASME Code Class 1 Small Bore Piping aging management Program Description sub-section of LRA Section B.2.1.22 is revised on page B-142 as shown below. The first full paragraph on page B-142 from the existing LRA Program Description is shown. Revisions are indicated with **bold italics** for inserted text and ~~strike throughs~~ for deleted text.

B.2.1.22 One-Time Inspection of ASME Code Class 1 Small-Bore Piping

Program Description

Byron Unit 1 and 2 have been operating for approximately 29 years and 27 years, respectively, at the time of license renewal application submittal (less than 30 years) and Braidwood Unit 1 and 2 have each been operating for approximately 27 years and 26 years, respectively, at the time of license renewal application submittal (less than 30 years), and have not experienced cracking of ASME Code Class 1 small-bore piping due to intergranular stress corrosion or fatigue due to cyclical loading. ***In 1998, Byron Unit 1 experienced a crack of a Class 1 Safety bore socket weld on the "D" safety injection system cold leg injection line, which did not appear to be age related. The replacement weld will be included in the Byron Unit 1 socket weld inspection sample population for the One-Time Inspection of ASME Code Class 1 Small-Bore Piping aging management program. This will confirm that a periodic inspection program of the Safety Injection system cold leg injection lines is not required and that the One-Time Inspection of ASME Code Class 1 Small-Bore Piping aging management program is appropriate.*** ~~Since each of the Byron and Braidwood units has a population of more than 250 ASME Code Class 1 socket welds less than NPS 4 and greater than or equal to NPS 1, the inspection sample size will be 25 socket welds for each unit. Also, since each of the Byron and Braidwood units has a population of at least 160 ASME Code Class 1 butt welds less than NPS 4 and greater than NPS 1, and an assumed population of minimum of approximately 90 butt welds equal to NPS 1, the inspection sample size will be 25 butt welds for each unit.~~ ***The inspection sample size will include 10% of the socket weld population up to a maximum of 25 socket welds for each Byron and Braidwood unit and 10% of the butt weld population up to a maximum of 25 butt welds for each Byron and Braidwood unit.*** This ensures an adequate sample size to provide confidence that the aging effect of cracking is not an issue at Byron and Braidwood. Sample locations will be selected based on susceptibility for cracking due to intergranular stress corrosion cracking and fatigue due to cyclical loading, consequence of failure, inspectability, dose considerations, operating experience, and limiting locations of the total population of ASME Code Class 1 small-bore piping locations. RI-ISI program high or medium risk ASME Code Class 1 small-bore piping butt and socket welds will be utilized as input for the selection of new One-Time Inspection of ASME Code Class 1 Small-Bore Piping aging management program inspection locations. Technical justification of the methodology and sample size used for selecting components will be documented in procedural controls.

As a result of the response to RAI B.3.1.1-2 provided in Enclosure A of this letter, enhancement 4 is added to LRA Appendix A, Section A.3.1.1, on page A-46 as shown below. The addition is indicated with ***bold italics***.

The Fatigue Monitoring aging management program will be enhanced to:

1. Address the cumulative fatigue damage effects of the reactor coolant environment on component life by evaluating the impact of the reactor coolant environment on critical components for the plant identified in NUREG/CR-6260. Additional plant-specific component locations in the reactor coolant pressure boundary will be evaluated if they are more limiting than those considered in NUREG/CR-6260.
2. Monitor and track additional plant transients that are significant contributors to component fatigue usage.
3. Evaluate the effects of the reactor coolant system water environment on the reactor vessel internal components with existing fatigue CUF analyses to satisfy the evaluation requirements of ASME Code, Section III, Subsection NG-2160 and NG-3121.
4. ***Increase the scope of the program to include transients used in the analyses for ASME Section III fatigue exemptions, the allowable stress analyses associated with ASME Section III and ANSI B31.1, and the flaw evaluation analyses performed in accordance with ASME Section XI, IWB-3600.***

As a result of the response to RAI B.3.1.1-2 provided in Enclosure A of this letter, the Fatigue Monitoring aging management program Program Description subsection of LRA Section B.3.1.1 the third paragraph on page B-279 and continuing on page B-280 is revised as shown below. The addition is indicated with ***bold italics***.

Program Description

Maintaining the number of cumulative cycles below the analyzed allowable cycle limits assures that the fatigue analyses remains valid. If a cycle limit is approached or the severity of an actual operational transient is not bounded by the applicable design transient definition, the condition is entered into the corrective action program. Fatigue analyses exists for BBS reactor pressure vessels (RPV) components and reactor coolant pressure boundary (RCPB) piping components in accordance with ASME Section III, Class 1 fatigue design requirements per the current licensing basis. This includes the analyses provided in the original stress reports as well as subsequent analyses developed to evaluate design changes, power rerates, and operational events. These Class 1 fatigue analyses have been identified as Time-Limited Aging Analyses (TLAAs) that are evaluated in Section 4.0 of the Byron and Braidwood License Renewal Application. In addition, components designed in accordance with ASME Section III, Class 2 and 3 and ANSI B31.1 requirements have been identified as having implicit fatigue Time-Limited Aging Analyses (TLAAs). ***The program will be enhanced to increase the scope of the program to include transients used in the analyses for ASME Section III fatigue exemptions, the allowable stress analyses associated with ASME Section III and ANSI B31.1, and the flaw evaluation analyses in accordance with ASME Section XI, IWB-3600.***

As a result of the response to RAI B.3.1.1-2 provided in Enclosure A of this letter, Enhancement 4 is added to the Enhancements sub-section of LRA Section B.3.1.1, the Fatigue Monitoring aging management program, starting on page B-280, and continuing on page B-281 as shown below. The addition is indicated with ***bold italics***.

Enhancements

Prior to the period of extended operation, the following enhancements will be implemented in the following program elements:

1. Address the cumulative fatigue damage effects of the reactor coolant environment on component life by evaluating the impact of the reactor coolant environment on critical components for the plant identified in NUREG/CR-6260. Additional plant-specific component locations in the reactor coolant pressure boundary will be evaluated if they are more limiting than those considered in NUREG/CR-6260. **Program Elements Affected: Scope of Program (Element 1), Preventive Actions (Element 2), Parameters Monitored/Affected (Element 3), Acceptance Criteria (Element 6); Corrective Actions (Element 7)**
2. Monitor and track additional plant transients that are significant contributors to component fatigue usage. **Program Elements Affected: Scope of Program (Element 1), Preventive Actions (Element 2), Parameters Monitored/Affected (Element 3), Acceptance Criteria (Element 6), Corrective Actions (Element 7)**
3. Evaluate the effects of the reactor coolant system water environment on the reactor vessel internal components with existing fatigue CUF analyses to satisfy the evaluation requirements of ASME Code, Section III, Subsection NG-2160 and NG-3121. **Program Elements Affected: Scope of Program (Element 1), Preventive Actions (Element 2), Parameters Monitored/Affected (Element 3), Acceptance Criteria (Element 6), Corrective Actions (Element 7)**
4. ***Increase the scope of the program to include transients used in the analyses for ASME Section III fatigue exemptions, the allowable stress analyses associated with ASME Section III and ANSI B31.1, and the flaw evaluation analyses in accordance with ASME Section XI, IWB-3600. Program Elements Affected: Scope of Program (Element 1), Preventive Actions (Element 2), Parameters Monitored/Affected (Element 3), Acceptance Criteria (Element 6), Corrective Actions (Element 7)***

As a result of the response to RAI B.2.1.7-5 provided in enclosure A of this letter, Table A of LRA Appendix C, "Response to Applicant/Licensee Action Items for Inspection and Evaluation Guidelines for Pressurized Water Reactor (PWR) Vessel Internals (MRP-227-A)," pages C-18 through C-21, is revised as follows:

Table A - BBS Primary Components (based on MRP-227-A Table 4.3)				
BBS Specific Item	Aging Effect	Expansion Link	Examination Method/Frequency	Examination coverage
Baffle-to-Former Assembly: Accessible Baffle-to-Former Bolts	Cracking Loss of Fracture Toughness Loss of Preload Changes in Dimensions (Note 1)	Lower Support Assembly: Lower Support Column Bolts, Baffle-to-Former Assembly: Barrel-to-Former Bolts	Baseline volumetric (UT) examination between 25 and 35 EFPY, with subsequent examination on a ten-year interval.	100% of accessible bolts. Heads accessible from the core side. UT accessibility may be affected by complexity of head and locking device designs. A minimum of 75% of the total population (examined + unexamined), including coverage consistent with the Expansion criteria in Table C, must be examined for inspection credit. See MRP-227-A Figures 4-23 and 4-24.

Table A - BBS Primary Components (based on MRP-227-A Table 4.3)				
BBS Specific Item	Aging Effect	Expansion Link	Examination Method/Frequency	Examination coverage
Baffle-to-Former Assembly: Baffle and Former Plates	Cracking Loss of Fracture Toughness (Note 2) Changes in Dimensions	None.	Visual (VT-3) examination to check for evidence of distortion, with baseline examination between 20 and 40 EFPY and subsequent examinations on a ten-year interval.	Core side surfaces. See MRP-227-A Figures 4-24, 4-25, 4-26, and 4-27.
Control Rod Guide Tube (CRGT) Assemblies: CRGT Guide Plates (cards)	Loss of Material Cracking (Note 4) Loss of Fracture Toughness (Note 2) Changes in Dimensions (Note 3)	None.	Visual (VT-3) examination no later than two (2) refueling outages from the beginning of the license renewal period of extended operation, and no earlier than two (2) refueling outages prior to the start of the license renewal period of extended operation. Subsequent examination on a ten-year interval.	20% examination of the number of CRGT assemblies, with all guide cards within each selected CRGT assembly examined. See MRP-227-A Figure 4-20.

Table A - BBS Primary Components (based on MRP-227-A Table 4.3)				
BBS Specific Item	Aging Effect	Expansion Link	Examination Method/Frequency	Examination coverage
Control rod Guide Tube (CRGT) Assemblies: CRGT Lower Flange Welds (accessible)	Cracking Loss of Fracture Toughness Changes in Dimensions (Note 3)	Bottom-Mounted Instrumentation System: Bottom-Mounted Instrumentation (BMI) Column Bodies Upper Internals Assembly (Upper Core Plate), Lower Support Assembly: Lower Support Forging	Enhanced visual (EVT-1) examination to determine the presence of crack-like surface flaws in flange welds no later than two (2) refueling outages from the beginning of the license renewal period of extended operation and subsequent examination on a ten-year interval.	100% of outer (accessible) CRGT lower flange weld surfaces and adjacent base metal on the individual periphery CRGT assemblies. A minimum of 75% of the total identified sample population must be examined. See MRP-227-A Figure 4-21.
Core Barrel Assembly: Lower Core Barrel Flange Weld	Cracking Loss of Fracture Toughness (Note 2) Changes in Dimensions (Note 3)	None.	Periodic enhanced visual (EVT-1) examination, no later than two (2) refueling outages from the beginning of the license renewal period of extended operation and subsequent examination on a ten-year interval.	100% of one side of the accessible surfaces of the selected weld and adjacent base metal. A minimum of 75% of the total weld length (examined + unexamined), including coverage consistent with the Expansion criteria in Table C, must be examined from either the inner or outer diameter for inspection credit.

Table A - BBS Primary Components (based on MRP-227-A Table 4.3)				
BBS Specific Item	Aging Effect	Expansion Link	Examination Method/Frequency	Examination coverage
Core Barrel Assembly: Upper Core Barrel Flange Weld	Cracking Loss of Fracture Toughness (Note 2) Changes in Dimensions (Note 3)	Lower support Assembly: Lower Support Column Bodies (non-cast), Core Barrel Assembly: Core Barrel Outlet Nozzle Welds	Periodic enhanced visual (EVT-1) examination, no later than two (2) refueling outages from the beginning of the license renewal period of extended operation and subsequent examination on a ten-year interval.	100% of one side of the accessible surfaces of the selected weld and adjacent base metal. A minimum of 75% of the total weld length (examined + unexamined), including coverage consistent with the Expansion criteria in Table C, must be examined from either the inner or outer diameter for inspection credit. See MRP-227-A Figure 4-22.

Table A - BBS Primary Components (based on MRP-227-A Table 4.3)				
BBS Specific Item	Aging Effect	Expansion Link	Examination Method/Frequency	Examination coverage
Core Barrel Assembly: Upper and Lower Core Barrel Cylinder Girth Welds	Cracking Loss of Fracture Toughness Changes in Dimensions (Note 3)	Core Barrel Assembly: Core Barrel Axial Welds	Periodic enhanced visual (EVT-1) examination, no later than two (2) refueling outages from the beginning of the license renewal period of extended operation and subsequent examination on a ten-year interval.	100% of one side of the accessible surfaces of the selected weld and adjacent base metal. A minimum of 75% of the total weld length (examined + unexamined), including coverage consistent with the Expansion criteria in Table C, must be examined from either the inner or outer diameter for inspection credit. See MRP-227-A Figure 4-22.

Notes:

1. ***Aging effect of Change in Dimensions, due to void swelling, on this component is managed through management of Change in Dimensions, due to void swelling, on the entire baffle-former assembly.***
2. ***The impact of the aging effect of Loss of Fracture Toughness was determined to be of minimal significance for this component per MRP-191 and MRP-227-A. However, if during the scheduled component examination any indication of degradation due to Loss of Fracture Toughness is observed, the condition should be entered into the corrective action program and evaluated. Since the impact of the aging effect of Loss of Fracture Toughness was determined to be of minimal significance, pre-defined acceptance criteria and expansion criteria are not necessary.***
3. ***The impact of the aging effect of Changes in Dimensions was determined to be of minimal significance for this component per MRP-191 and MRP-227-A. However, if during the scheduled component examination any indication of degradation due to Changes in Dimensions is observed, the condition should be entered into the corrective action program and evaluated. Since the impact of the aging effect of Changes in Dimensions was determined to be of minimal significance, pre-defined acceptance criteria and expansion criteria are not necessary.***

4. ***The impact of the aging effect of Cracking was determined to be of minimal significance for this component per MRP-191 and MRP-227-A. However, if during the scheduled component examination any indication of degradation due to Cracking is observed, the condition should be entered into the corrective action program and evaluated. Since the impact of the aging effect of Cracking was determined to be of minimal significance, pre-defined acceptance criteria and expansion criteria are not necessary.***

As a result of the response to RAI B.2.1.7-5 provided in enclosure A of this letter, Table B of LRA Appendix C, "Response to Applicant/Licensee Action Items for Inspection and Evaluation Guidelines for Pressurized Water Reactor (PWR) Vessel Internals (MRP-227-A)," pages C-22 through C-25, is revised as follows:

Table B – BBS Expansion Components (based on MRP-227-A Table 4.6)				
Item	Aging Effect	Primary Link	Examination Method/Frequency	Examination coverage
Baffle-to-Former Assembly: Barrel-to-Former Bolts	Cracking Loss of Fracture Toughness Loss of Preload Changes in Dimensions	Baffle-to-Former Assembly: Accessible Baffle-to-Former Bolts	Volumetric (UT) examination. Re-inspection every ten (10) years following initial <i>inspection.</i>	100% of accessible bolts. Accessibility may be limited by presence of neutron pads. A minimum of 75% coverage of the entire examination area or volume, or a minimum sample size of 75% of the total population of like components of the examination is required (including both the accessible and inaccessible portions). See MRP-227-A Figure 4-23

Table B – BBS Expansion Components (based on MRP-227-A Table 4.6)

Item	Aging Effect	Primary Link	Examination Method/Frequency	Examination coverage
Bottom-Mounted Instrumentation System: Bottom-Mounted Instrumentation (BMI) Column Bodies	Cracking Loss of Fracture Toughness Changes in Dimensions (Note 1)	Control rod Guide Tube (CRGT) Assemblies: CRGT Lower Flange Welds (accessible)	Visual (VT-3) examination of BMI column bodies as indicated by difficulty of insertion/withdrawal of flux thimbles. Re-inspection every ten (10) years following initial inspection. Flux thimble insertion/withdrawal to be monitored at each inspection interval.	100% of BMI column bodies for which difficulty is detected during flux thimble insertion/withdrawal. See MRP-227-A Figure 4-35.
Core Barrel Assembly: Core Barrel Axial Welds	Cracking Loss of Fracture Toughness Changes in Dimensions (Note 1)	Core Barrel Assembly: Upper and Lower Core Barrel Cylinder Girth Welds	Enhanced visual (EVT-1) examination. Re-inspection every ten (10) years following initial inspection.	100% of one side of the accessible surfaces or the selected weld and adjacent base metal. A minimum of 75% coverage of the entire examination area or volume, or a minimum sample size of 75% of the total population of like components of the examination is required (including both the accessible and inaccessible portions). See MRP-227-A Figure 4-22.

Table B – BBS Expansion Components (based on MRP-227-A Table 4.6)

Item	Aging Effect	Primary Link	Examination Method/Frequency	Examination coverage
Core Barrel Assembly: Core Barrel Outlet Nozzle Welds	Cracking Loss of Fracture Toughness Changes in Dimensions (Note 1)	Core Barrel Assembly: Upper Core Barrel Flange Weld	Enhanced visual (EVT-1) examination. Re-inspection every ten (10) years following initial inspection.	100% of one side of the accessible surfaces or the selected weld and adjacent base metal. A minimum of 75% coverage of the entire examination area or volume, or a minimum sample size of 75% of the total population of like components of the examination is required (including both the accessible and inaccessible portions). See MRP-227-A Figure 4-22.
Lower Internals Assembly: Lower Support Forging	Cracking Loss of Fracture Toughness (Note 2) Changes in Dimensions (Note 1)	Control rod Guide Tube (CRGT) Assemblies: CRGT Lower Flange Welds (accessible)	Enhanced visual (EVT-1) examination. Re-inspection every ten (10) years following initial inspection.	100% of accessible surfaces. A minimum of 75% coverage of the entire examination area or volume, or a minimum sample size of 75% of the total population of like components of the examination is required (including both the accessible and inaccessible portions). See MRP-227-A Figure 4-33.

Table B – BBS Expansion Components (based on MRP-227-A Table 4.6)				
Item	Aging Effect	Primary Link	Examination Method/Frequency	Examination coverage
Lower Support Assembly: Lower Support Column Bodies (non-cast)	Cracking Loss of Fracture Toughness Changes in Dimensions (Note 1)	Core Barrel Assembly: Upper Core Barrel Flange Weld	Enhanced visual (EVT-1) examination. Re-inspection every ten (10) years following initial inspection.	100% of one side of the accessible surfaces or the selected weld and adjacent base metal. A minimum of 75% coverage of the entire examination area or volume, or a minimum sample size of 75% of the total population of like components of the examination is required (including both the accessible and inaccessible portions). See MRP-227-A Figure 4-34.

Table B – BBS Expansion Components (based on MRP-227-A Table 4.6)

Item	Aging Effect	Primary Link	Examination Method/Frequency	Examination coverage
Lower Support Assembly: Lower Support Column Bolts	Cracking Loss of Fracture Toughness Loss of Preload Changes in Dimensions (Note 1)	Baffle-to-Former Assembly: Accessible Baffle-to-Former Bolts	Volumetric (UT) examination. Re-inspection every ten (10) years following initial inspection.	100% of accessible bolts or as supported by plant-specific justification. A minimum of 75% coverage of the entire examination area or volume, or a minimum sample size of 75% of the total population of like components of the examination is required (including both the accessible and inaccessible portions). See MRP-227-A Figures 4-32 and 4-33.
Upper Internals Assembly (Upper Core Plate)	Cracking Loss of Fracture Toughness (Note 2) Changes in Dimensions (Note 1)	Control rod Guide Tube (CRGT) Assemblies: CRGT Lower Flange Welds (accessible)	Enhanced visual (EVT-1) examination. Re-inspection every ten (10) years following initial inspection.	100% of accessible surfaces. A minimum of 75% coverage of the entire examination area or volume, or a minimum sample size of 75% of the total population of like components of the examination is required (including both the accessible and inaccessible portions).

Notes:

- 1. The impact of the aging effect of Changes in Dimensions was determined to be of minimal significance for this component per MRP-191 and MRP-227-A. However, if during the scheduled component examination any indication of degradation due to Changes in Dimensions is observed, the condition should be entered into the corrective action program and evaluated. Since the impact of the aging effect of Changes in Dimensions was determined to be of minimal significance, pre-defined acceptance criteria and expansion criteria are not necessary.**
- 2. The impact of the aging effect of Loss of Fracture Toughness was determined to be of minimal significance for this component per MRP-191 and MRP-227-A. However, if during the scheduled component examination any indication of degradation due to Loss of Fracture Toughness is observed, the condition should be entered into the corrective action program and evaluated. Since the impact of the aging effect of Loss of Fracture Toughness was determined to be of minimal significance, pre-defined acceptance criteria and expansion criteria are not necessary.**

As a result of changes to the Reactor Vessel Surveillance aging management program identified in the response to B.2.1.19-1, LRA Appendix A, Section A.2.1.19, page A-25 is revised as shown below. Revisions are indicated with ***bold italics*** for inserted text and ~~strikethroughs~~ for deleted text:

A.2.1.19 Reactor Vessel Surveillance

The Reactor Vessel Surveillance aging management program is an existing condition monitoring program that extends the scope of 10 CFR Part 50, Appendix H, "Reactor Vessel Material Surveillance Program Requirements." The program provides sufficient material and dosimetry data to monitor loss of fracture toughness due to neutron irradiation embrittlement until the end of the period of extended operation, and determine the need for operating restrictions on the irradiation temperature (i.e., cold leg operating temperature), neutron spectrum, and neutron fluence. There were six (6) specimen capsules installed in each Byron and Braidwood Station (BBS) reactor pressure vessel (RPV) prior to plant start-up. The capsules contain representative RPV material specimens, neutron dosimeters, and thermal monitors (eutectic alloy). All six (6) specimen capsules have been withdrawn from each of the BBS RPVs. Three (3) specimen capsules from each RPV were tested and the remaining three (3) untested specimen capsules from each RPV are currently stored in the spent fuel pool. Of the three (3) untested specimen capsules from each RPV at least one (1) untested specimen capsule has been irradiated in excess of the projected peak neutron fluence of the associated RPV at the end of the period of extended operation. Capsules that have been withdrawn will be tested as necessary to fulfill the surveillance capsule recommendations contained in ASTM 185-82 as required by 10 CFR Part 50, Appendix H. Operating restrictions will be established to ensure that the plant is operated under the conditions to which the surveillance capsules were exposed. All capsules tested for the period of extended operation will meet the test procedures and reporting requirements of ASTM E 185-82, "Standard Practice for Conducting Surveillance Tests for Light-Water Cooled Nuclear Power Reactor Vessels" to the extent practicable for the configuration of the specimens in the capsule. Any changes to the capsule withdrawal schedule, including spare capsules, must be approved by the NRC prior to implementation. Untested capsules placed in storage must be maintained for possible future insertion.

The program also monitors plant operating conditions to ensure appropriate steps are taken if reactor vessel exposure conditions are altered, such as the review and updating of 60-year fluence projections to support upper shelf energy calculations and pressure-temperature limit curves. The program also includes condition monitoring by removal and analysis of ex-core neutron dosimetry sensor sets to validate neutron exposure projection calculations through the period of extended operation in accordance with Regulatory Guide 1.190, "Calculational and Dosimetry Methods for Determining Pressure Vessel Neutron Fluence." These measures are effective in monitoring the extent of neutron irradiation embrittlement to prevent significant degradation of the reactor pressure vessel during the period of extended operation.

The Reactor Vessel Surveillance aging management program will be enhanced to:

1. Establish operating restrictions to ensure that the plant is operated under the conditions to which the surveillance capsules were exposed. The operating

restrictions are as follows:

Byron Station, Unit 1:

- Cold leg operating temperature limitation: 525 degrees Fahrenheit (minimum) to 590 degrees Fahrenheit (maximum)
- RPV beltline material fluence: 3.21E+19 n/cm² (E >1.0 MeV) (maximum)

Byron Station, Unit 2; Braidwood Station, Units 1 and 2:

- Cold leg operating temperature limitation: 525 degrees Fahrenheit (minimum) to 590 degrees Fahrenheit (maximum)
- RPV beltline material fluence: 3.19E+19 n/cm² (E >1.0 MeV) (maximum)

Braidwood Station, Unit 2:

- Cold leg operating temperature limitation: 525 degrees Fahrenheit (minimum) to 590 degrees Fahrenheit (maximum)
- **RPV beltline material fluence: 3.16E+19 n/cm² (E >1.0 MeV) (maximum)**

If the reactor pressure vessel exposure conditions (neutron fluence, neutron spectrum) or irradiation temperature (cold leg inlet temperature) are altered, then the basis for the projection to the end of the period of extended operation needs to be reviewed and, if deemed appropriate, updates are made to the Reactor Vessel Surveillance program. Any changes to the Reactor Vessel Surveillance program must be submitted for NRC review and approval in accordance with 10 CFR Part 50, Appendix H.

2. **One (1) specimen capsule per reactor vessel, as designated below, irradiated to a neutron fluence of one (1) to two (2) times the projected peak neutron fluence at the end of the period of extended operation will be withdrawn from the spent fuel pool, tested, and the summary technical report submitted to the NRC prior to entering the associated period of extended operation.**

Reactor Vessel (Station , Unit)	Capsule ID	Capsule Fluence (n/cm²)(E>1.0 MeV)
Byron, Unit 1	Y	3.97E+19
Byron, Unit 2	Y	4.19E+19
Braidwood, Unit 1	V	3.71E+19

<i>Braidwood, Unit 2</i>	<i>V</i>	<i>3.73E+19</i>
---------------------------------	-----------------	------------------------

~~These~~ enhancements will be implemented prior to the period of extended operation.

As a result of changes to the Reactor Vessel Surveillance aging management program identified in the response to B.2.1.19-1, LRA Appendix B, Section B.2.1.19, page B-127, second paragraph is revised as shown below. Revisions are indicated with ***bold italics*** for inserted text and ~~strikethroughs~~ for deleted text:

Braidwood Station, Unit 2 has one (1) untested specimen capsule irradiated in excess of the end of period of extended operation projected peak neutron fluence of ~~3.169E+19~~ ***3.73E+19*** n/cm² (E >1.0 MeV). Specimen capsule ~~V~~ ***V*** was pulled during the Braidwood Station, Unit 2 Fall 2009 Refueling Outage and was irradiated to ~~3.73E+19~~ ***3.73E+19*** n/cm² (E >1.0 MeV).

As a result of changes to the Reactor Vessel Surveillance aging management program identified in the response to B.2.1.19-1, LRA Appendix B, Section B.2.1.19, pages B-127 through B-128, Enhancements are revised as shown below. Revisions are indicated with ***bold italics*** for inserted text and ~~strikethroughs~~ for deleted text:

Enhancements

Prior to the period of extended operation, the following enhancements will be implemented in the following program elements:

1. Establish operating restrictions to ensure that the plant is operated under the conditions to which the surveillance capsules were exposed. The operating restrictions are as follows:

Byron Station, Unit 1:

- Cold leg operating temperature limitation: 525 degrees Fahrenheit (minimum) to 590 degrees Fahrenheit (maximum)
- RPV beltline material fluence: 3.21E+19 n/cm² (E >1.0 MeV) (maximum)

Byron Station, Unit 2; Braidwood Station, Units 1 ~~and 2~~:

- Cold leg operating temperature limitation: 525 degrees Fahrenheit (minimum) to 590 degrees Fahrenheit (maximum)
- RPV beltline material fluence: 3.19E+19 n/cm² (E >1.0 MeV) (maximum)

Braidwood Station, Unit 2:

- Cold leg operating temperature limitation: 525 degrees Fahrenheit (minimum) to 590 degrees Fahrenheit (maximum)
- **RPV beltline material fluence: 3.16E+19 n/cm2 (E >1.0 MeV) (maximum)**

If the reactor pressure vessel exposure conditions (neutron fluence, neutron spectrum) or irradiation temperature (cold leg inlet temperature) are altered, then the basis for the projection to the end of the period of extended operation needs to be reviewed and, if deemed appropriate, updates are made to the Reactor Vessel Surveillance program. Any changes to the Reactor Vessel Surveillance program must be submitted for NRC review and approval in accordance with 10 CFR Part 50, Appendix H. **Program Elements Affected: Parameters Monitored/Inspected (Element 3), Detection of Aging Effects (Element 4), Monitoring and Trending (Element 5), Acceptance Criteria (Element 6)**

2. **One (1) specimen capsule per reactor vessel, as designated below, irradiated to a neutron fluence of one (1) to two (2) times the projected peak neutron fluence at the end of the period of extended operation will be withdrawn from the spent fuel pool, tested, and the summary technical report submitted to the NRC prior to entering the associated period of extended operation.**

Reactor Vessel	Capsule ID	Capsule Fluence (n/cm²)(E>1.0 MeV)
Byron, Unit 1	Y	3.97E+19
Byron, Unit 2	Y	4.19E+19
Braidwood, Unit 1	V	3.71E+19
Braidwood, Unit 2	V	3.73E+19

Program Elements Affected: Parameters Monitored/Inspected (Element 3), Detection of Aging Effects (Element 4), Monitoring and Trending (Element 5), Acceptance Criteria (Element 6)

Enclosure C

Byron and Braidwood Stations (BBS) Units 1 and 2 License Renewal Commitment List Changes

This Enclosure identifies commitments made in this document and is an update to the Byron and Braidwood Station (BBS) LRA Appendix A, Table A.5 License Renewal Commitment List. Any other actions discussed in the submittal represent intended or planned actions and are described to the NRC for the NRC's information and are not regulatory commitments. Changes to the BBS LRA Appendix A, Table A.5 License Renewal Commitment List are as a result of the Exelon response to the following RAI:

RAI B.2.1.22-1
RAI B.3.1.1-2
RAI B.2.1.19-1

Notes:

- To facilitate understanding, portions of the original License Renewal Commitment List have been repeated in this Enclosure, with revisions indicated.
- Existing LRA text is shown in normal font. Changes are highlighted with ***bold italics*** for inserted text and ~~strikethroughs~~ for deleted text.

As a result of the response to RAI B.2.1.22-1 provided in Enclosure A of this letter, LRA Appendix A, Table A.5 License Renewal Commitment List, line item 2 on page A-79 is revised as shown below. The RAI that led to this commitment modification is listed in the "SOURCE" column. Any other actions described in this submittal represent intended or planned actions. They are described for the NRC's information and are not regulatory commitments. Revisions are indicated with ***bold italics*** for inserted text.

A.5 License Renewal Commitment List

NO.	PROGRAM OR TOPIC	COMMITMENT	IMPLEMENTATION SCHEDULE	SOURCE
22	One-Time Inspection of ASME Code Class 1 Small-Bore Piping	<p>One-Time Inspection of ASME Code Class 1 Small-Bore Piping is a new program that will manage the aging effect of cracking in Class 1 small-bore piping that is less than nominal pipe size (NPS) 4-inches, and greater than or equal to NPS 1-inch.</p> <p><i>The socket weld sample population for Byron Unit 1 will include the socket weld on the "D" safety injection system cold leg injection line that was replaced in 1998.</i></p>	<p>Program to be implemented prior to the period of extended operation.</p> <p>One-time Inspections will be performed and evaluated within the six (6) year period prior to the period of extended operation.</p>	<p>Section A.2.1.22</p> <p><i>Exelon Letter RS-14-002 RAI B.2.1.22-1 01/13/2014</i></p>

As a result of the response to RAI B.3.1.1-2, Item 43 on pages A-92 and A-93 of the License Renewal Commitment List is revised to add enhancement 4 as shown below. The RAI that led to this commitment modification is listed in the "SOURCE" column. Any other actions described in this submittal represent intended or planned actions. They are described for the NRC's information and are not regulatory commitments.

A.5 License Renewal Commitment List

NO.	PROGRAM OR TOPIC	COMMITMENT	IMPLEMENTATION SCHEDULE	SOURCE
43	Fatigue Monitoring	<p>Fatigue Monitoring is an existing program that will be enhanced to:</p> <ol style="list-style-type: none"> 1. Address the cumulative fatigue damage effects of the reactor coolant environment on component life by evaluating the impact of the reactor coolant environment on critical components for the plant identified in NUREG/CR-6260. Additional plant-specific component locations in the reactor coolant pressure boundary will be evaluated if they are more limiting than those considered in NUREG/CR-6260. 2. Monitor and track additional plant transients that are significant contributors to component fatigue usage. 3. Evaluate the effects of the reactor coolant system water environment on the reactor vessel internal components with existing fatigue CUF analyses to satisfy the evaluation requirements of ASME Code, Section III, Subsection NG-2160 and NG-3121. 4. <i>Increase the scope of the program to include transients used in the analyses for ASME Section III fatigue exemptions, the allowable stress analyses associated with ASME Section III and ANSI B31.1, and the flaw evaluation analyses performed in accordance with ASME Section XI, IWB-3600.</i> 	<p>Program to be enhanced prior to the period of extended operation.</p> <p>Environmental fatigue evaluations to be performed prior to the period of extended operation.</p>	<p>Section A.3.1.1</p> <p><i>Exelon letter RS-14-002 RAI B.3.1.1-2 01/13/ 2014</i></p>

As a result of the response to RAI B.2.1.19-1 provided in Enclosure A of this letter, LRA Appendix A, Table A.5 License Renewal Commitment List, line item 19 on pages A-78 and A-79, is revised as shown below. The RAI that led to this commitment modification is listed in the "SOURCE" column. Any other actions described in this submittal represent intended or planned actions. They are described for the NRC's information and are not regulatory commitments.

A.5 License Renewal Commitment List

NO.	PROGRAM OR TOPIC	COMMITMENT	IMPLEMENTATION SCHEDULE	SOURCE
19	Reactor Vessel Surveillance	<p>Reactor Vessel Surveillance is an existing program that will be enhanced to:</p> <ol style="list-style-type: none"> Establish operating restrictions to ensure that the plant is operated under the conditions to which the surveillance capsules were exposed. The operating restrictions are as follows: <p style="margin-left: 40px;">Byron Station, Unit 1:</p> <ul style="list-style-type: none"> - Cold leg operating temperature limitation: 525 degrees Fahrenheit (minimum) to 590 degrees Fahrenheit (maximum). - RPV beltline material fluence: 3.21E+19 n/cm2 (E >1.0 MeV) (maximum). <p style="margin-left: 40px;">Byron Station, Unit 2; Braidwood Station, Units 1 and 2:</p> <ul style="list-style-type: none"> - Cold leg operating temperature limitation: 525 degrees Fahrenheit (minimum) to 590 degrees Fahrenheit (maximum). - RPV beltline material fluence: 3.19E+19 n/cm2 (E >1.0 MeV) (maximum). <p style="margin-left: 40px;">Braidwood Station, Unit 2:</p> <ul style="list-style-type: none"> - Cold leg operating temperature limitation: 525 degrees Fahrenheit (minimum) to 590 degrees Fahrenheit (maximum). - RPV beltline material fluence: 3.16E+19 n/cm2 (E >1.0 MeV) (maximum). 	Program to be enhanced prior to the period of extended operation.	<p>Section A.2.1.19</p> <p>Exelon Letter RS-14-002 RAI B.2.1.19-1 01/13/2014</p>

NO.	PROGRAM OR TOPIC	COMMITMENT	IMPLEMENTATION SCHEDULE	SOURCE															
		<p>If the reactor pressure vessel exposure conditions (neutron fluence, neutron spectrum) or irradiation temperature (cold leg inlet temperature) are altered, then the basis for the projection to the end of the period of extended operation needs to be reviewed and, if deemed appropriate, updates are made to the Reactor Vessel Surveillance program. Any changes to the Reactor Vessel Surveillance program must be submitted for NRC review and approval in accordance with 10 CFR Part 50, Appendix H.</p> <p>2. <i>One (1) specimen capsule per reactor vessel, as designated below, irradiated to a neutron fluence of one (1) to two (2) times the projected peak neutron fluence at the end of the period of extended operation will be withdrawn from the spent fuel pool, tested, and the summary technical report submitted to the NRC prior to entering the associated period of extended operation.</i></p> <table border="1" data-bbox="646 873 1297 1162"> <thead> <tr> <th><i>Reactor Vessel (Station, Unit)</i></th> <th><i>Capsule ID</i></th> <th><i>Capsule Fluence (n/cm²)(E>1.0 MeV)</i></th> </tr> </thead> <tbody> <tr> <td><i>Byron, Unit 1</i></td> <td><i>Y</i></td> <td><i>3.97E+19</i></td> </tr> <tr> <td><i>Byron, Unit 2</i></td> <td><i>Y</i></td> <td><i>4.19E+19</i></td> </tr> <tr> <td><i>Braidwood, Unit 1</i></td> <td><i>V</i></td> <td><i>3.71E+19</i></td> </tr> <tr> <td><i>Braidwood, Unit 2</i></td> <td><i>V</i></td> <td><i>3.73E+19</i></td> </tr> </tbody> </table>	<i>Reactor Vessel (Station, Unit)</i>	<i>Capsule ID</i>	<i>Capsule Fluence (n/cm²)(E>1.0 MeV)</i>	<i>Byron, Unit 1</i>	<i>Y</i>	<i>3.97E+19</i>	<i>Byron, Unit 2</i>	<i>Y</i>	<i>4.19E+19</i>	<i>Braidwood, Unit 1</i>	<i>V</i>	<i>3.71E+19</i>	<i>Braidwood, Unit 2</i>	<i>V</i>	<i>3.73E+19</i>		
<i>Reactor Vessel (Station, Unit)</i>	<i>Capsule ID</i>	<i>Capsule Fluence (n/cm²)(E>1.0 MeV)</i>																	
<i>Byron, Unit 1</i>	<i>Y</i>	<i>3.97E+19</i>																	
<i>Byron, Unit 2</i>	<i>Y</i>	<i>4.19E+19</i>																	
<i>Braidwood, Unit 1</i>	<i>V</i>	<i>3.71E+19</i>																	
<i>Braidwood, Unit 2</i>	<i>V</i>	<i>3.73E+19</i>																	